



# LUND UNIVERSITY

## Methods for determination of duration of surface moisture and presence of water in gaps in wood joints

Fredriksson, Maria; Wadsö, Lars; Johansson, Peter

*Published in:*  
Wood Science and Technology

*DOI:*  
[10.1007/s00226-013-0549-4](https://doi.org/10.1007/s00226-013-0549-4)

2013

*Document Version:*  
Peer reviewed version (aka post-print)

[Link to publication](#)

*Citation for published version (APA):*  
Fredriksson, M., Wadsö, L., & Johansson, P. (2013). Methods for determination of duration of surface moisture and presence of water in gaps in wood joints. *Wood Science and Technology*, 47(5), 913-924.  
<https://doi.org/10.1007/s00226-013-0549-4>

*Total number of authors:*  
3

### General rights

Unless other specific re-use rights are stated the following general rights apply:  
Copyright and moral rights for the publications made accessible in the public portal are retained by the authors and/or other copyright owners and it is a condition of accessing publications that users recognise and abide by the legal requirements associated with these rights.

- Users may download and print one copy of any publication from the public portal for the purpose of private study or research.
- You may not further distribute the material or use it for any profit-making activity or commercial gain
- You may freely distribute the URL identifying the publication in the public portal

Read more about Creative commons licenses: <https://creativecommons.org/licenses/>

### Take down policy

If you believe that this document breaches copyright please contact us providing details, and we will remove access to the work immediately and investigate your claim.

LUND UNIVERSITY

PO Box 117  
221 00 Lund  
+46 46-222 00 00

# Methods for determination of duration of surface moisture and presence of water in gaps in wood joints

Maria Fredriksson<sup>a\*</sup>, Lars Wadsö<sup>a</sup>, Peter Johansson<sup>a</sup>

<sup>a</sup> *Division of Building Materials, Lund University, Box 118, 221 00 Lund, Sweden*

\*Author to whom correspondence should be addressed; e-mail: maria.fredriksson@byggtek.lth.se, tel. +46 46 222 74 12, fax: +46 46 222 44 27

## ABSTRACT

If water stays on wood surfaces or is trapped in gaps, the wood is supplied with water during a long period of time and high local moisture contents are reached. This can lead to decay by rot fungi and it is therefore important to avoid such water traps in order to limit the decay rate. This paper presents two methods; one for determination of duration of surface moisture on wood surfaces and one for determination of duration of water trapped in gaps in wood joints. Both these methods are based on similar electrical conductance measurements as are commonly used to measure moisture content of wood. Both sensor types consist of insulating tubing, electrically conductive adhesive and copper wire. The sensors monitor the presence of moisture on the actual material surface and because of their small size they do not influence the amount and duration of moisture that stays on the surface or in the gap.

## 1. INTRODUCTION

In building science, duration of surface moisture is a parameter that can be used to forecast degradation phenomena such as wood decay, biological fouling and corrosion. The moisture state of wood surfaces is of special interest since wood is susceptible to surface fouling by mould fungi, algae and more seriously, to decay by rot fungi if exposed to high moisture contents during long periods of time. The decay rate in joints in outdoor structures is influenced by its design (De Groot and Highley 1995); if water stays on wood surfaces or is trapped in gaps, the wood is supplied with water during long periods of time and high local moisture contents are reached. It is therefore important to avoid such water traps in order to limit the durations of high moisture content and thus also the risk for decay.

To predict the service life of a structure, a model where the exposure is compared to its resistance can be used (see e.g. Isaksson et al. 2012). For wood outdoors, the relevant exposure parameter is the moisture and temperature conditions in the wood. To predict moisture and temperature conditions in the wood from climate data, the macro-climate (precipitation, temperature, RH etc.) needs to be transformed into a micro-climate, i.e., the climate at the wood surface. The moisture and temperature conditions in the wood can then be calculated using heat and mass transfer models with the micro-climate as boundary condition. To verify such a model it is therefore necessary to measure not only moisture content but also the boundary conditions, i.e. the duration of surface moisture and water trapped in gaps.

There is an interest in measuring the time during which surfaces are wet also in other fields of science and technology. For example, the duration of surface (leaf) wetness is an important factor when forecasting plant disease (see e.g. Wallin (1967)) and for metal surfaces the parameter “time of wetness” is used to predict corrosion (see e.g. Cole et al. (1995)).

Therefore, several surface moisture sensors have been developed for these purposes. Most of these sensors measure the change in electrical resistance or capacitance due to moisture either on the sensor surface (Davis and Hughes 1970; Gillespie and Kidd 1978; Fraigi et al. 1994; Wei et al. 1995; Sereda et al. 1982; Weiss and Lukens 1981; Smith and Gilpatrick 1980) or on the material surface of interest (Schurer and Van Der Wal 1972; Giesler et al. 1996; Weiss et al. 1988; Burkhardt and Gerchau 1994; Häckel 1974, 1980). Apart from these electrical sensors there are also mechanical types (see e.g. Wallin (1963)), beta-ray gauge sensors (Barthakur 1985; Bunnenberg and Kuhn 1977) and optical sensors (Zlochyn and Seginer

2001; Griffioen et al. 1992; Heusinkveld et al. 2008). A review of different types of leaf wetness sensors was made by Huber (1992).

However, for wood and other building materials both material specific methods and sensors developed for purposes described above are used to monitor duration of surface moisture. Nore et al. (2006) measured duration of surface moisture on a wooden facade by using a method similar to the one used for moisture content measurements. Electrodes connected to a moisture content meter were mounted so that the tips were in contact with the surface of the wooden cladding. Sveipe et al. (2011) used a sensor with two wires connected by a sheet of paper and double-sided tape to measure surface moisture on vacuum insulation panels. The sensor was connected to a moisture content meter which measured the electrical resistance between the wires. Norberg (1999) used a surface moisture sensor where the time of wetness was monitored on the sensor surface. See et al. (1988) used two methods to monitor surface moisture on carbonate building stones; one leaf wetness sensor with a gypsum coating and one sensor of their own design. This sensor consisted of electrodes mounted on both sides of a piece of limestone. A similar method was used by Nady et al. (1997) who made a ceramic resistance sensor consisting of a small block of clay brick ( $19 \times 10 \times 5 \text{ mm}^3$ ) with two wires fastened by electrically conductive epoxy on opposite sides of the brick. Since the electrical resistance decreases when the brick is wet this was used as an indication of presence of surface moisture. Bernardi et al. (2006) used two types of sensors to detect condensation on glass surfaces; one leaf wetness sensor where the presence of water on the sensor surface was monitored and one optical sensor of their own design which monitored the presence of water on the glass surface. They found that the leaf wetness sensor registered longer wetness periods than the optical sensor which measured directly on the glass surface.

Most wetness sensors monitor the wetness on the sensor surface rather than the wetness on the material surface of interest. This is a problem if the surface properties of the actual material are different from the surface properties of the sensor, for example if the thermal absorbance of the sensor is not matched to that of the surface or if the material absorbs water but the sensor does not. Another factor that needs to be considered is the risk that the sensor itself traps moisture which would make the measured duration of surface moisture longer than if no sensor was present.

Some surface moisture sensors give a reading also when the surface is dry. This means that a “dry value” or a baseline must be defined to determine whether the surface is wet or not

(Giesler et al. 1996). However, if the material absorbs water the baseline value may vary with the moisture content of the material. Nore et al. (2006) solved this by also measuring the moisture content of the wood material on which the surface moisture measurements were made. Both the surface moisture sensor, which consisted of two electrodes in contact with the surface, and the moisture content electrodes were connected to a moisture content meter. Wetness was registered only when the reading of the wetness sensor exceeded that of the moisture content sensor.

Unlike surface moisture sensors, not many sensors that monitor the presence of water in gaps have been described in literature. However, optical methods used in fundamental studies on wetting in glass capillaries exist (Fattinger et al. 1987).

This paper presents two methods; one for determination of duration of surface moisture on wood surfaces and one for determination of duration of water trapped in gaps between two pieces of wood. The method for surface moisture determination enables measurement of surface moisture on the actual wood surface without major disturbances by the sensor itself. Both methods are based on similar electrical conductance measurements that are commonly used to measure moisture content in wood. The sensors were developed for use in laboratory tests, but the surface moisture sensor was also tested in field measurements.

## 2. METHODS

### 2.1 Duration of surface moisture

The surface moisture sensors were made of capillary tubing (PEEK tubing, outer diameter: 1.59 mm, inner diameter: 1 mm), electrically conductive adhesive (EPO-TEK E4110, Epoxy Technology Inc., Billerica MA, USA) and uninsulated copper wire (diameter 0.5 mm) (Fig. 1a). A hole (diameter 1.6 mm) was drilled through the wood specimen and the capillary tubing was inserted so that the end of the tubing was in level with the upper wood surface where the surface moisture should be measured. The copper wire was then soaked in electrically conductive adhesive and inserted through the capillary tubing from the back of the specimen. The adhesive was needed to keep the wires in place and also to prevent water from running from the upper surface down through the capillary tubing. The adhesive needs to be electrically conductive; otherwise the copper wires will be insulated from each other also when there is water on the surface. The specimens were oven dried at 30 °C since heat curing improves the properties of the adhesive. Finally, the copper wires were cut about 2 mm above the upper wood surface. The lower parts of the copper wires, outside the capillary tubing, can be insulated with heat shrink tubing if water is present also on the back of the specimen.

The duration of surface moisture can be determined by measuring the conductance between two surface moisture sensors. When there is no water on the surface, the conductance is zero. In this study, the conductance was measured between pairs of three surface moisture sensors connected in parallel (Fig. 1b) so that a larger area was monitored.

### 2.2 Presence of water in gap

The design of the sensor used to monitor presence of water in gaps is shown in Figs. 2a and 2b. It was made with the same materials and with a similar technique as the surface moisture sensors described above. The sensors were mounted by drilling three holes (diameter 1.6 mm) at the edge of two pieces of wood (Fig. 2c). Capillary tubing were inserted in the holes and pulled back about 1 mm. The wood specimens were then placed upside down and electrically conductive adhesive was inserted through the tubing using a non-silicon-treated syringe (Luer Lock Hand Syringe and Posilok Perfectly Straight Stainless Steel 23G, Fishman Corporation, Hopkinton MA, USA) so that the space between the bottom of the hole and the tubing was filled with adhesive. Three copper wires, connected by a crimp pin that was soldered at the ends of the wires, were finally inserted through the three pieces of tubing

on each wood specimen until they reached the bottom of the holes. The specimens were then oven dried at 30 °C as above. The electrically conductive adhesive is needed to ensure electrical contact between the copper wire and the wood surface. The copper wires outside the capillary tubing can be insulated with heat shrink tubing.

### 3. TEST MEASUREMENTS

#### 3.1 Laboratory measurements

##### 3.1.1 *Experimental set-up*

The specimen consisted of two pieces of Norway spruce (*Picea abies* L. Karst.) heartwood (300 × 95 × 22 mm<sup>3</sup>, longitudinal × tangential × radial) mounted in a transparent plastic (PMMA) box so that only the upper surface and the two end grain surfaces facing each other were exposed to water. The distance between the two end grain surfaces was 2 mm. Water was poured on the specimen until the area of measurement (see Fig. 3) was entirely covered with water. The electrical conductance between the surface moisture sensors and the sensors that monitored the presence of water in the gap was logged every fifteenth second. The logger was custom built and the measurement range was 0.001-200 μS. Each conductance reading was performed as follows: a voltage of 2 V was applied and after 0.5 s the first reading was made during 0.5 s; the polarity was then switched and after 0.5 s another reading was made during 0.5 s. The registered conductance reading was the average between these two readings.

During the measurements, the specimen was also monitored visually. Observations on if there was water in the gap, if there was a water film on the surface and if the surface looked dry were made each minute. The surface was considered dry when there was no visible line between the wetted area and the area that had been kept dry (see Fig. 3). The surface moisture measurements were repeated four times and the measurements of water in the gap were repeated three times.

##### 3.1.2 *Results*

Typical curves from the measurements of duration of surface moisture and the presence of water in the gap are shown in Figs. 4 and 5, respectively. The visual observations of when there was water in the gap correlated well with the measured conductance. However, the surface moisture sensors sometimes gave a low conductance reading a short time after no liquid film was visible on the surface.

## 3.2 Field measurements

### 3.2.1 *Experimental set-up*

The sensors that monitor duration of surface moisture were mounted on two wood specimens exposed outdoors in Lund, Sweden. The sensors were connected to a wireless logger (Protimeter Hygrotrac, GE Sensing, Billerica MA, USA) intended for moisture content determinations in wood and the output from the logger was therefore wood moisture content in percent. A surface moisture reading was registered each hour. No moisture on the surface corresponded to the lowest moisture content that the logger was able to measure (8%). This value was subtracted from all values in Figs. 6-7 so that zero is no moisture on the surface.

The weather during the period of measurement was also registered so that the reading from the surface moisture sensors could be correlated with periods of rainfall. Measurements during one year were evaluated.

### 3.2.2 *Results*

The output from the surface moisture sensors in the field measurements corresponded well to the rainfall data and the two surface moisture sensors gave similar readings (Fig. 6). During the spring and summer months, the surface moisture sensors gave a reading during nights and mornings even if no rain was registered (Fig. 7). This is probably due to dew. During the winter months, when the temperature was below zero degrees Celsius, the surface moisture reading seldom reached zero probably because there were snow or frost on the surface. During the whole year, the smaller fluctuations in surface moisture correlated with fluctuations in air relative humidity.

## 4. DISCUSSION

The correlation between the measured conductance and the visual observations were good for both the surface moisture sensor and the sensor that monitors presence of water in a gap. Both sensors monitor the presence of moisture on the actual material surfaces rather than on a sensor surface. This is advantageous since wood absorbs water and has surface properties which are significantly different from the surfaces of the wetness sensors that are commonly used. Since such sensors are developed for use on a particular material, e.g. leaf wetness sensors are designed so that the wetting and drying of the sensor is similar to the wetting and drying of the leaf (Davis and Hughes 1970; Griffioen et al. 1992), they might give inaccurate results if used on a material with different surface properties. This was experienced by



Bernardi et al. (2006) who found that leaf wetness sensors used on glass surfaces registered longer wetness periods than their own sensor which measured directly on the glass surface.

#### 4.1 Duration of surface moisture

For a surface moisture sensor that measures the conductance between two points on an wood surface the situation can be schematically described as in Fig. 8a. When moisture is present on the surface – either from rain or from condensation – it can leave the surface by evaporation or absorption. The sensor is insulated from the bulk of the wood material (see the design of the surface sensors in Fig. 1a) and it therefore measures conductance on the surface and a reading is given only when water is present. However, when there is water on the surface, the measured conductance is not only the conductance of the water layer but a combination of the water layer and the wood.

If there is water on the surface this will contain charged molecules that conduct electricity even when the layer of water on the surface is small. If the water layer has the same thickness over the whole surface, the sensor will show a high conductance when  $h > 0$ , but essentially zero conductance when the surface is dry and  $h = 0$ . However, at high  $h$  it can be assumed that  $h$  is the same over a flat surface, but at low mean  $h$  the surface moisture may tend to limit itself to patches. The sensor will then only indicate surface moisture if there is a continuous moisture film between the measuring points. This problem can be minimized by measuring between several points on the surface as was done in this study; as long as two points have contact the sensor will indicate that there is water on the surface. Single droplets of water between the sensors will not be detected if the surface surrounding the droplets is dry unless the droplets are in contact with the sensors.

The design of the surface moisture sensors does not include a sealing between the capillary tubing and the wood as such sealing materials can change the properties of the material. If water can enter between the capillary tubing and the wood there is a risk that the surface water does not reach the copper wires; instead a “dry island” is created around the copper wires which then will lose contact with each other. However, this has not been observed in this study, probably because wood swells when it is wetted and thus no space between the wood and the capillary tubing exists. Nevertheless, this might be an issue if the surface moisture sensors are mounted in a non-swelling material.

The sensor described in the literature that is most similar to the sensors we have presented in the present paper, is the sensor described by Giesler et al. (1996) designed to measure leaf

wetness in a turf grass canopy. This sensor consisted of two small stainless steel pins (0.1 or 0.2 mm diameter) of the type that are used in entomological collections. The pins were inserted through a blade of grass and the resistance between the pins was measured. Similar to the surface moisture sensor in the present study the sensor by Giesler et al. (1996) measured the wetness on the surface of interest rather than on the sensor surface. Because of the small size of the electrodes, both methods measure surface wetness without any major disturbance on the wetting and drying of the material surface. However, unlike the sensor described by Giesler et al. (1996) the electrodes in the present study are insulated and only have contact when there is water on the surface. Thus, the reading is zero when no water is present and no subtraction of a baseline needs to be performed. This is advantageous since the resistance of wood changes with its moisture content and the baseline would therefore, in this case, not be constant.

#### *4.1.1 Surface moisture sensors in field tests*

The surface moisture sensors were tested in field measurements during one year. Since the sensors give a reading also when the surface is moist and no liquid film is present the periods of time when the reading is zero are rather short. However, the magnitude of the reading from the sensor gives an indication of the amount of moisture on the surface; a higher value is registered after rainfall than if dew is present on the surface (cf. Fig. 6 and 7). Note also that it is important that the sensors are kept clean during the measurements as leaves etc. on the surface may give false surface moisture readings.

#### 4.2 Presence of water in gaps

The situation for water in a gap is more complex than for moisture on a surface as is indicated in Fig. 8b. There are at least two potentially absorbing surfaces and sometimes more than one surface from which water can evaporate. However, the evaporation tends to be much lower than for a surface as a gap only exposes a small liquid-air interface. A sensor that senses whether there is water in a gap will sense a high conductance when there is water between the points of measurement. However, if the water does not directly connect the points of the sensor, a lower conductance is registered since the sensors on the opposing sides then only have contact through the wood or through the water film on the wood surfaces. For a conducting material such as wood it may possible to differ between the three cases (see Fig. 9):

1. Moisture between measuring points.

2. Moisture meniscus somewhere else in gap.

3. No water in the gap.

This means that a high conductance value does not necessarily mean that there is a large amount of water in the gap. The conductance reading also depends on the position of the water in the gap. If measurements are made on a non-conducting material case 2 is somewhat different; the sensor then only gives a reading if there is a thin moisture film on the surfaces.

## 5. CONCLUSIONS

The correlation between the measured conductance and the visual observations were good for both methods. The small sensors enable measurement of presence of water in gaps and duration of surface moisture on the actual material surface without major disturbances by the sensor itself. The surface moisture sensors can also be connected to a wireless logger for use in field tests.

## ACKNOWLEDGEMENTS

Thord Isaksson is gratefully acknowledged for providing the field measurement data.

This project is part of WoodBuild, a research programme within the Sectoral R&D Programme 2006-2012 for the Swedish forest-based industry. This Programme is jointly funded by the government, industry and other stakeholders with interests related to the Swedish forest-based industry.

## REFERENCES

- Barthakur NN (1985) A comparative study of radiometric and electronic leaf wetness sensors. *Agricultural and Forest Meteorology* 36 (1):83-90.
- Bernardi A, Becherini F, Bassato G, Bellio M (2006) Condensation on ancient stained glass windows and efficiency of protective glazing systems: two French case studies, Sainte-Chapelle (Paris) and Saint-Urbain Basilica (Troyes). *Journal of Cultural Heritage* 7 (1):71-78.
- Bunnenberg C, Kuhn W (1977) Application of beta-absorption method to measure dew on soil and plant surfaces. *International Journal of Applied Radiation and Isotopes* 28 (9):751-754.
- Burkhardt J, Gerchau J (1994) A new device for the study of water-vapor condensation and gaseous deposition to plant-surfaces and particle samples. *Atmospheric Environment* 28 (12):2012-2017.
- Cole IS, Holgate R, Kao P, Ganther W (1995) The rate of drying of moisture from a metal surface and its implication for time of wetness. *Corrosion Science* 37 (3):455-465.
- Davis DR, Hughes JE (1970) A new approach to recording the wetting parameter by the use of electrical resistance sensors. *Plant Disease Reporter* 54 (6):474-479.

- De Groot RC, Highley TL (1995) Forest Products Laboratory methodology for monitoring decay in wood exposed above ground. In: Proceedings of IRG Annual Meeting, 1995. IRG/WP 11-40569.
- Fattering C, Togni G, Lukosz W (1987) Wetting in narrow gaps and capillaries: temperature- and surface-pressure-induced wetting transitions. *Surface Science* 189/190:405-410.
- Fraigi L, Gwiric SN, Lupi D (1994) A thick-film sensor for atmospheric corrosion testing. *Sensors and Actuators B-Chemical* 19 (1-3):558-561.
- Giesler LJ, Horst GL, Yuen GY (1996) A site-specific sensor for measuring leaf wetness duration within turfgrass canopies. *Agricultural and Forest Meteorology* 81 (1-2):145-156.
- Gillespie TJ, Kidd GE (1978) Sensing duration of leaf moisture retention using electrical-impedance grids. *Canadian Journal of Plant Science* 58 (1):179-187.
- Griffioen H, Kornet JG, Schurer K (1992) An optical leaf wetness sensor. *Acta Horticulturae* 304:127-135.
- Heusinkveld BG, Berkowicz SM, Jacobs AFG, Hillen W, Holtslag AAM (2008) A new remote optical wetness sensor and its applications. *Agricultural and Forest Meteorology* 148 (4):580-591.
- Huber L (1992) Causes of wetness periods and measurement of leaf wetness duration for plant-protection purposes. *Agronomie* 12 (4):281-295.
- Häckel H (1974) Electrical method for measuring wetness duration immediately on leaves. *Agricultural Meteorology* 13 (1):91-103.
- Häckel H (1980) New developments of an electrical method for direct measurement of the wetness-duration on plants. *Agricultural Meteorology* 22 (2):113-119.
- Isaksson T, Brischke C, Thelandersson S (2012) Development of decay performance models for outdoor timber structures. *Materials and Structures*, doi: 10.1617/s11527-012-9965-4.
- Nady M, Said A, Brown WC, Walker IS (1997) Long-term field monitoring of an EIFS clad wall. *Journal of Building Physics (Journal of Thermal Insulation and Building Envelopes)* 20 (4):320-338.
- Norberg P (1999) Monitoring wood moisture content using the WETCORR method. Part 1: Background and theoretical considerations. *Holz als Roh- und Werkstoff* 57 (6):448-453.
- Nore K, Thue JV, Rydock JP (2006) A comparison of time-of-wetness and wind-driven rain measurements on wooden cladding. Paper presented at the the 5th International Conference on Cold Climate - Heating, Ventilation and Air-Conditioning, Moscow, Russia,
- Schurer K, Van Der Wal AF (1972) An electronic leaf wetness recorder. *Netherlands Journal of Plant Pathology* 78 (1):29-32.
- See RB, Reddy MM, Martin RG (1988) Description and testing of three moisture sensors for measuring surface wetness on carbonate building stones. *Review of scientific instruments* 59 (10):2279-2284.
- Sereda PJ, G CS, F SH (1982) Measurement of the time of wetness by moisture sensors and their calibration. *Atmospheric Corrosion of Metals ASTM STP 767:267-285.*
- Smith CA, Gilpatrick JD (1980) Geneva leaf wetness detector. *Plant Disease* 64 (3):286-288.
- Sveipe E, Jelle BP, Wegger E, Uvslokk S, Grynning S, Thue JV, Time B, Gustavsen A (2011) Improving thermal insulation of timber frame walls by retrofitting with vacuum insulation panels - experimental and theoretical investigations. *Journal of Building Physics* 35 (2):168-188.
- Wallin J (1967) Agrometeorological aspects of dew. *Agricultural Meteorology* 4 (2):85-102.

- Wallin JR (1963) Dew, its significance and measurement in phytopathology. *Phytopathology* 53 (10):1210-1216.
- Wei YQ, Bailey BJ, Stenning BC (1995) A wetness sensor for detecting condensation on tomato plants in greenhouses. *Journal of Agricultural Engineering Research* 61 (3):197-204.
- Weiss A, Lukens DL (1981) Electronic-circuit for detecting leaf wetness and comparison of two sensors. *Plant Disease* 65 (1):41-43.
- Weiss A, Lukens DL, Steadman JR (1988) A sensor for the direct measurement of leaf wetness - construction techniques and testing under controlled conditions. *Agricultural and Forest Meteorology* 43 (3-4):241-249.
- Zlochin I, Seginer I (2001) Fiber-optic leaf-wetness sensor: canopy condensation warning for greenhouses. *Acta Horticulturae* 562:401-406.

## FIGURES

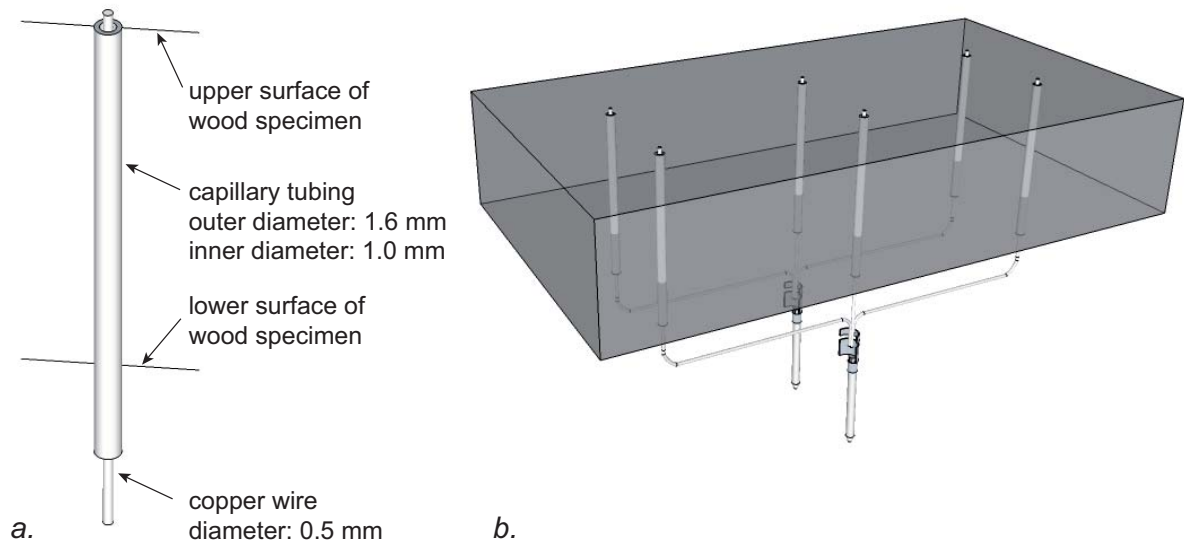

Figure 1. The sensor that monitors the duration of surface moisture (a) and six surface moisture sensors mounted in a wood specimen (b). The conductance is measured on the upper surface between groups of three sensors connected in parallel. The upper end of the capillary tubing is in level with the wood surface.

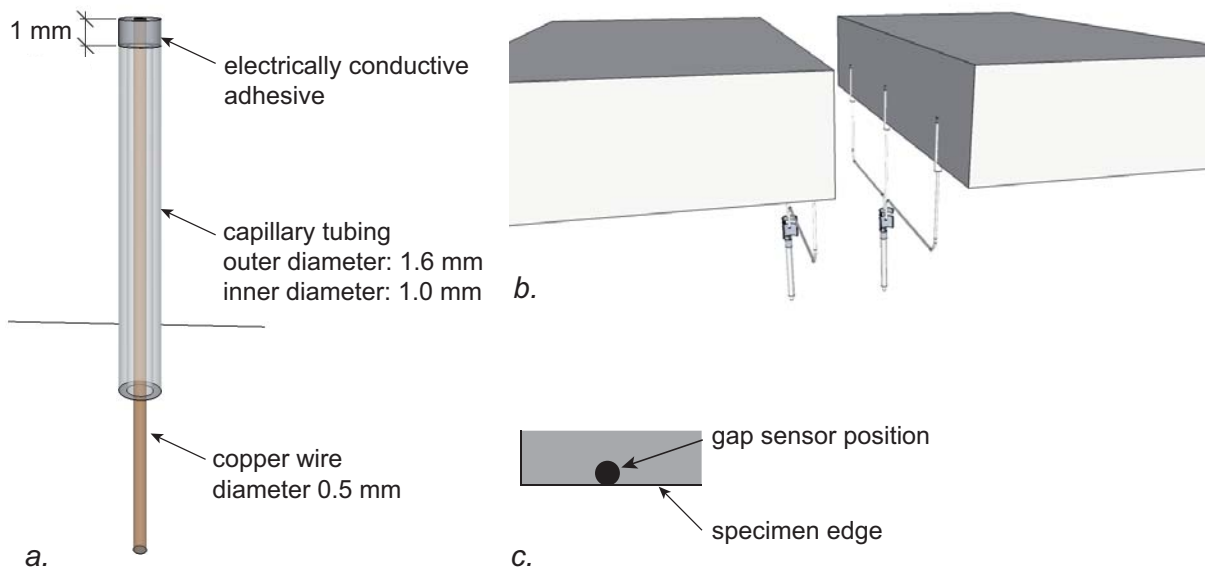

Figure 2. The design of the sensor for determination of presence of water in a gap (a) and three sensors mounted on opposite sides of a gap between two pieces of wood (b). The conductance was measured between groups of three sensors connected in parallel. The gap sensors were mounted so that the specimen edge is the tangent line to the circular capillary tubing (c).

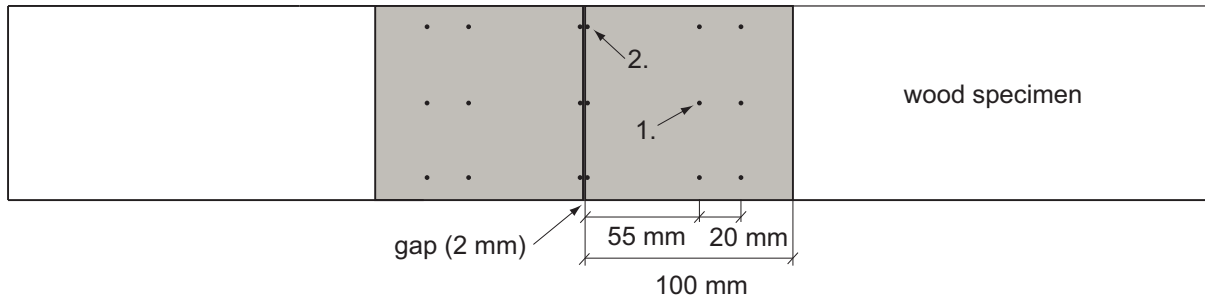

Figure 3. The specimen seen from above with the positions of the surface moisture sensors (1) and the sensors that monitor presence of water in the gap (2). The grey area indicates the wetted area.

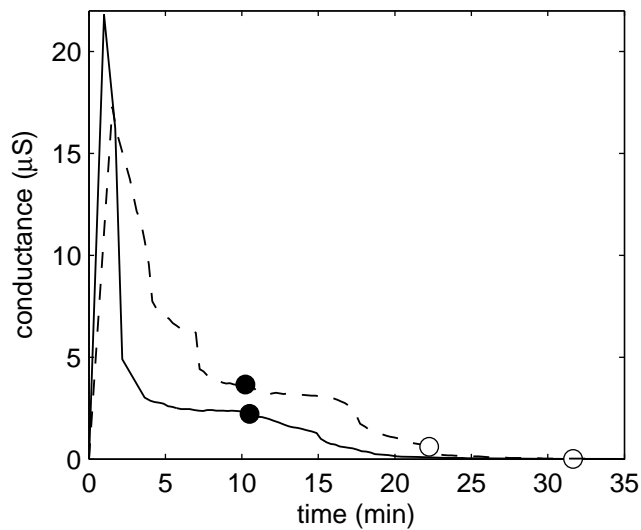

Figure 4. Two typical curves from the measurements of duration of surface moisture. The filled black circles indicate the approximate time when a free liquid film no longer was seen on the surface. The filled white circles indicate when the surface looked dry, i.e. when there was no visible line between the wetted area and the adjacent dry wood.

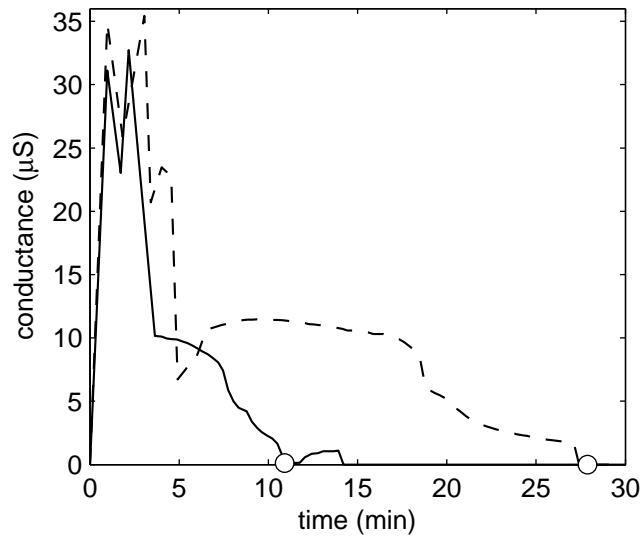

Figure 5. Presence of moisture in the gap, results from two measurements. The filled white circles show when water in the gap was no longer observed visually.

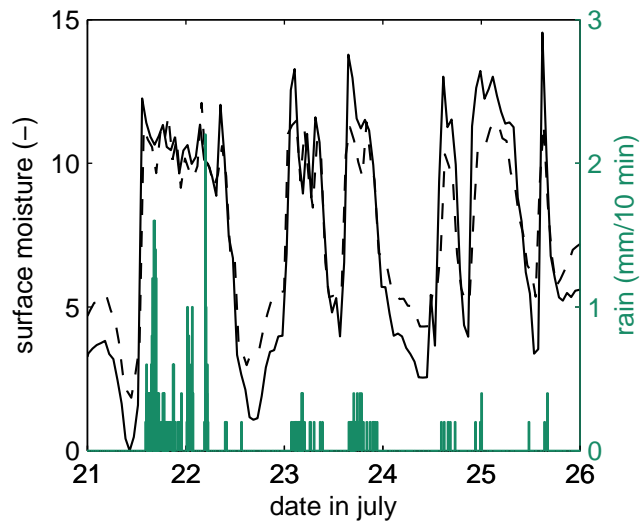

Figure 6. Data from the two surface moisture sensors (dashed and continuous lines) used in the field measurements and the rainfall data (bars) during five days in July 2011.



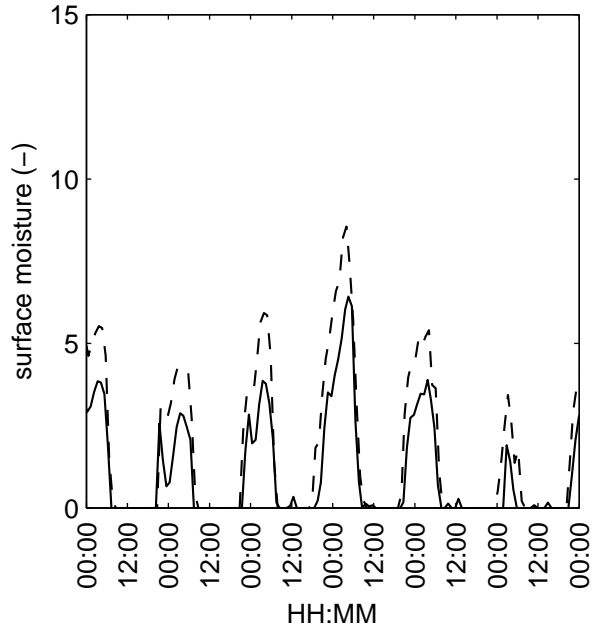

Figure 7. Data from two surface moisture sensors during six days in June 2011. Even though no rainfall was registered during this period the surface moisture sensors gave a reading during night and morning, probably due to dew.

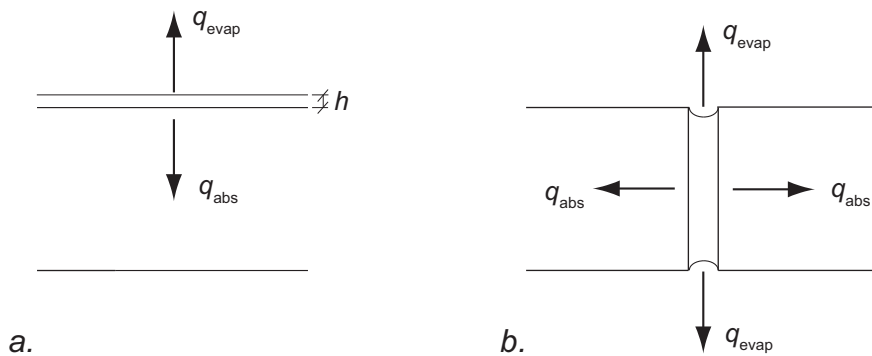

Figure 8. The wood specimen seen from the side. The surface moisture sensors will sense if there is water on the surface even when the layer of water on the surface,  $h$ , is small (a). The water can leave the surface either by evaporation,  $q_{\text{evap}}$ , or by being absorbed by the wood,  $q_{\text{abs}}$ . The situation for water in a gap is more complex (b) as there are at least two potentially absorbing surfaces and sometimes more than one exposed surface from which water can evaporate.

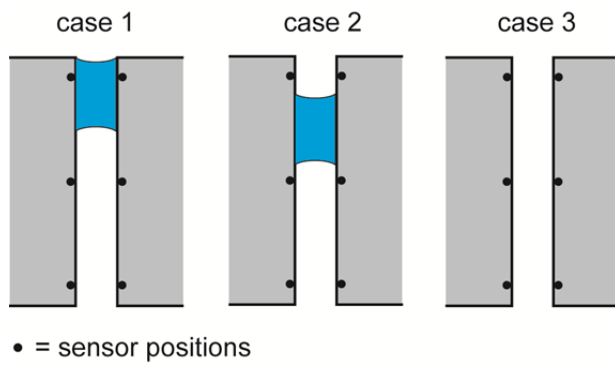

Figure 9. The specimen with the gap sensors seen from above. Case 1: Moisture between measuring points. Case 2: Moisture meniscus somewhere else in the gap. Case 3: No water in the gap.