



LUND UNIVERSITY

Tests of Full Size Rubber Foil Adhesive Joints

Gustafsson, Per-Johan

2007

Document Version:

Publisher's PDF, also known as Version of record

[Link to publication](#)

Citation for published version (APA):

Gustafsson, P.-J. (2007). *Tests of Full Size Rubber Foil Adhesive Joints*. (TVSM-7000; No. TVSM-7149). Division of Structural Mechanics, LTH.

Total number of authors:

1

General rights

Unless other specific re-use rights are stated the following general rights apply:

Copyright and moral rights for the publications made accessible in the public portal are retained by the authors and/or other copyright owners and it is a condition of accessing publications that users recognise and abide by the legal requirements associated with these rights.

- Users may download and print one copy of any publication from the public portal for the purpose of private study or research.
- You may not further distribute the material or use it for any profit-making activity or commercial gain
- You may freely distribute the URL identifying the publication in the public portal

Read more about Creative commons licenses: <https://creativecommons.org/licenses/>

Take down policy

If you believe that this document breaches copyright please contact us providing details, and we will remove access to the work immediately and investigate your claim.

LUND UNIVERSITY

PO Box 117
221 00 Lund
+46 46-222 00 00



LUND
UNIVERSITY



TESTS OF FULL SIZE RUBBER FOIL ADHESIVE JOINTS

PER JOHAN GUSTAFSSON

Structural
Mechanics

Department of Construction Sciences
Structural Mechanics

ISRN LUTVDG/TVSM--07/7149--SE (1-92)
ISSN 0281-6679

TESTS OF FULL SIZE RUBBER FOIL ADHESIVE JOINTS

PER JOHAN GUSTAFSSON

Copyright © 2007 by Structural Mechanics, LTH, Sweden.
Printed by KFS i Lund AB, Lund, Sweden, May 2007.

For information, address:
Division of Structural Mechanics, LTH, Lund University, Box 118, SE-221 00 Lund, Sweden.
Homepage: <http://www.byggmek.lth.se>

Table of contents

Acknowledgement	3
1. Introduction	5
2. Test series overview	7
2.1 Glulam-to-glulam lap joints	7
2.2 LVL-to-glulam lap joints	8
2.3 Steel rods glued into glulam	9
2.4 Steel plate-to-glulam lap joints	10
3. Test specimen manufacturing and materials, and testing locations	11
3.1 Manufacturing	11
3.2 Steel	11
3.3 Wood materials	11
3.4 Rubber	12
3.5 Glue	12
3.6 Nails and Teflon	12
3.7 Testing locations	12
4. Glulam-to-glulam joints	13
4.1 Test series 1a, single lap joint in flatwise bending	13
4.2 Test series 1b, single lap joint in edgewise bending	16
4.3 Test series 2, single lap joint in rolling shear	19
4.4 Test series 3a, 300 mm double lap joint in bending	22
4.5 Test series 3b, 600 mm double lap joint in bending	26
4.6 Test series 3c, 600 mm double lap joint in shear	30
5. LVL-to-glulam joints	35
5.1 Test series 4a, 160 mm lap joints in shear by tensile loading	35
5.2 Test series 4b, 320 mm lap joints in shear by tensile loading	38
5.3 Test series 5, 160 mm lap joint in perpendicular tension	41
6. Glued-in steel rods	45
6.1 Shaping of specimens	45
6.2 Test series 6a-9b, ramp loading of glued-in rods	47
6.3 Test series 10aR-10cD3, DOL testing of glued-in rods	56
7. Steel plate-to-glulam lap joints	59
7.1 Test series 11a, nailed 160 mm outer double lap joint	59
7.2 Test series 11b, glued 160 mm outer double lap joint	62
7.3 Test series 11c, nailed and glued 160 mm outer double lap joint	65
7.4 Test series 12, glued 160 mm inner double lap joint	69
7.5 Test series 13, glued 320 mm inner double lap joint	72
7.6 Test series 14a, glued plates loaded parallel with grain	76
7.7 Test series 14b, glued plates loaded perpendicular to grain	79
8. Concluding remarks	83
8.1 Lap joints	83
8.2 Glued-in steel rods	83
8.3 General	84
References	85
Appendix: Manufacturing of full scale joints	87

Acknowledgement

The experimental work on adhesive joints presented in this report was carried out 2005-2007 as a part of the work in a subtask on rubber foil adhesive joints in the joint Swedish-Finnish project "Innovative design, a new strength paradigm for joints, QA and reliability for long-span wood construction". This project is part of the "Wood Material Science and Engineering Research Programme" ("Wood Wisdom") and it has been supported by the following organisations and companies.

In Finland:

- TEKES (Finnish Funding Agency for Technology and Innovation)
- VTT
- SPU Systems Oy
- Metsäliitto Cooperative
- Versowood Oyj
- Late-Rakenteet Oy
- Exel Oyj

In Sweden:

- Vinnova (Swedish Governmental Agency for Innovation Systems)
- Skogsindustrierna
- Casco Products AB
- SFS-Intec AB
- Limträteknik i Falun AB
- Svenskt Limträ AB
- Skanska Teknik AB

The contributions and funding from the above mentioned parties are gratefully acknowledged. The companies underlined contributed in particular and directly to the subtask on rubber foil adhesive joints by doing work and supplying materials. Special thanks to Magnus Wikström and Peter Herder, Casco Products AB, to Roberto Crocetti, Moelven Töreboda AB and Svenskt Limträ AB, and to Jan-Inge Bengtsson, SFS-Intec AB. Special thanks also to Per-Olof Rosenkvist, Thord Lundgren and Per-Erik Austrell, LTH, to Sture Persson, Metso Minerals AB, to Arne Emilsson, Limträteknik i Falun AB, and to Anders Clang, SP.

April 2007, Per Johan Gustafsson

1. Introduction

This report presents the results of a testing program on full scale glued rubber foil adhesive joints manufactured and tested 2005-2007. Most of the tests relate to the load carrying capacity at short time ramp loading. A few long duration of constant load tests were also made. The results are presented in terms of observed failure mechanisms, pictures, failure load, nominal failure stress and recorded load versus displacement performance.

The configuration of rubber foil adhesive joints is illustrated in the below figure. The purpose of the rubber foil is to increase the load bearing capacity and enable elastic joint behavior. Increase in load bearing capacity is because the flexibility of the rubber layer enables distribution of the load, thus reducing stress concentrations and making the entire bond area active in carrying the load. Also other advantages with the elastic bond performance are probable, e.g. very good impact strength, less cracking and moisture variation induced stresses in the wood and good interaction with nails due to the possibility to choose bond stiffness.

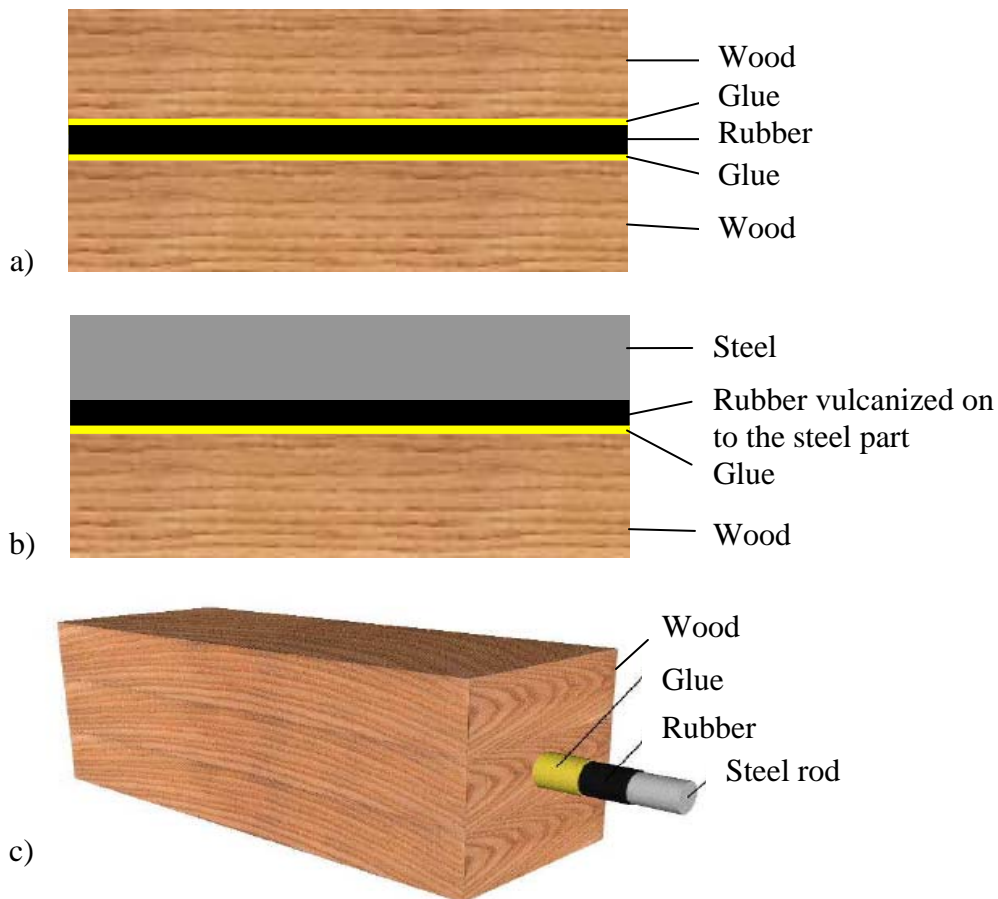

Build up of rubber foil adhesive joints:

- a) Wood-to-wood joint.
- b) Steel-to-wood joint.
- c) Glued-in steel rod.

2. Test series overview

Four basic kinds of joints were tested:

- Glulam-to-glulam lap joints
- LVL-to-glulam lap joints
- Steel rods glued into glulam
- Steel plate-to-glulam lap joints

2.1 Glulam-to-glulam lap joints

The 6 test series are defined in the below table. The joining was for all test series made by rubber foil adhesive joining. In each of the 6 series were 3 nominally equal specimens tested. The glulam-to-glulam tests are presented in Chapter 4.

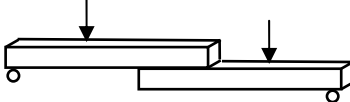
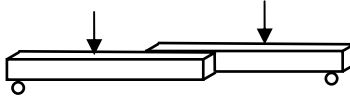
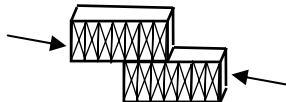
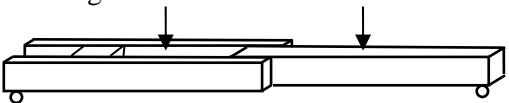
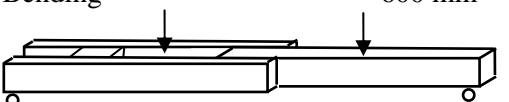
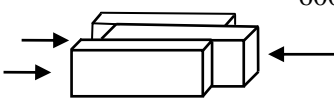
Series no	Type of loading.	Lap length	Glulam, mm ³
1a	Flatwise bending 	360 mm	2 x (88 x 88 x 1000)
1b	Bending 	360 mm	2 x (88 x 88 x 1000)
2	Rolling shear 	90 mm	2 x (88 x 223 x 90)
3a	Bending 	300 mm	2 x (88 x 223 x 1700) + 1 x (163 x 223 x 1700)
3b	Bending 	600 mm	2 x (88 x 223 x 1700) + 1 x (163 x 223 x 1700)
3c	Shear 	600 mm	2 x (88 x 223 x 780) + 1 x (163 x 223 x 780)

2.2 LVL-to-glulam lap joints

The 3 test series are defined below. The joining was for all test series made by rubber foil adhesive joining and nails. In each of the 3 series were 3 nominally equal specimens tested. The LVL-to-glulam tests are presented in Chapter 5.

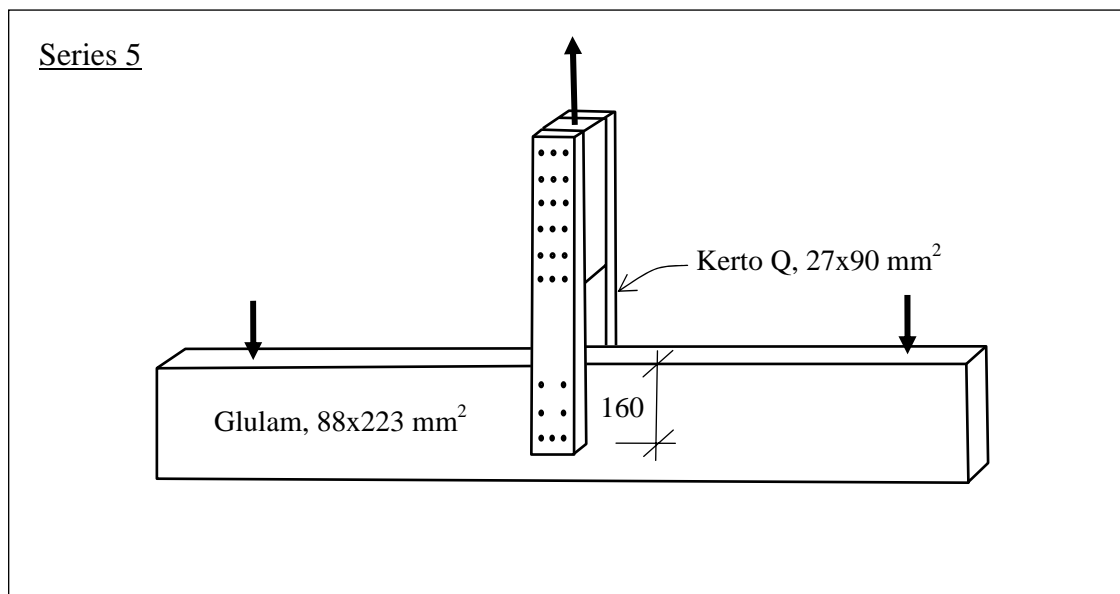
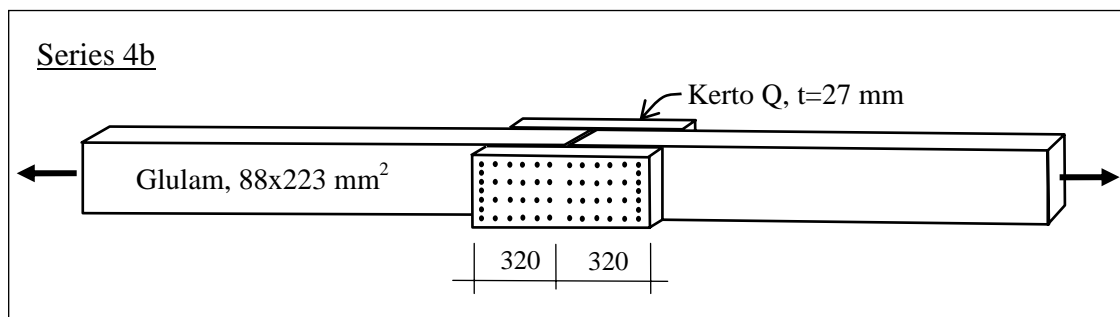
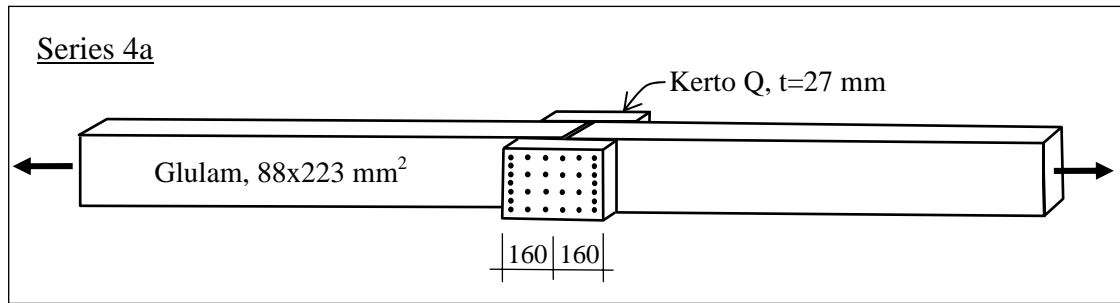

2.3 Steel rods glued into glulam



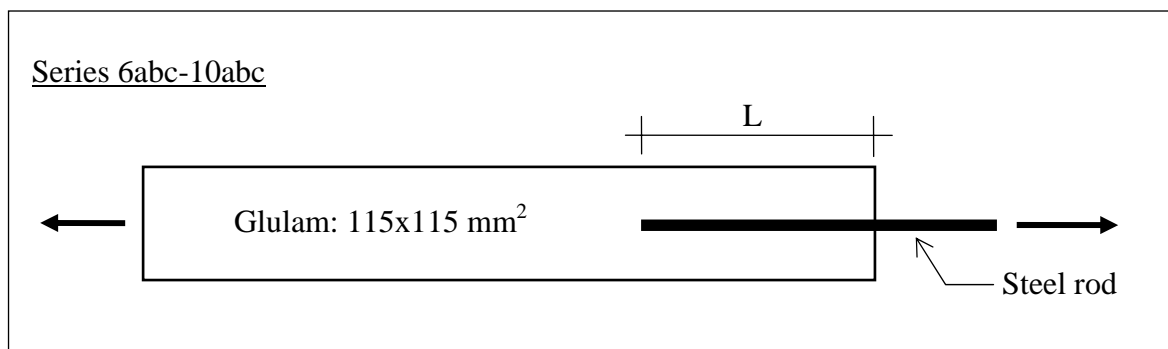

The pull-out strength of glued-in steel rods were tested in 12 ramp loading test series and in 9 time-to-failure at constant load test series. The 9 duration of load (DOL) test series were made at three different load levels. 8 of the series related to steel rods vulcanized with a rubber coating while the other series served as reference tests series. The glued-in rod tests are presented in Chapter 6.



Series	N.o.s.	Rod surface	Rod diameter	L, mm	Loading
6a	4	Smooth	18.3 mm	160	Ramp
6b	4	Vulcanized	18.3 mm	160	Ramp
6c	4	Threaded	M20	160	Ramp
7a	4	Smooth	18.3 mm	320	Ramp
7b	4	Vulcanized	18.3 mm	320	Ramp
8a	4	Smooth	18.3 mm	480	Ramp
8b	4	Vulcanized	18.3 mm	480	Ramp
9a	4	Smooth	18.3 mm	640	Ramp
9b	4	Vulcanized	18.3 mm	640	Ramp
10aR	2	Smooth	14.6 mm	160	Ramp
10bR	3	Vulcanized	14.6 mm	160	Ramp
10cR	3	Threaded	M16	160	Ramp
10aD1	3	Smooth	14.6 mm	160	DOL-1
10bD1	3	Vulcanized	14.6 mm	160	DOL-1
10cD1	3	Threaded	M16	160	DOL-1
10aD2	3	Smooth	14.6 mm	160	DOL-2
10bD2	3	Vulcanized	14.6 mm	160	DOL-2
10cD2	3	Threaded	M16	160	DOL-2
10aD3	3	Smooth	14.6 mm	160	DOL-3
10bD3	3	Vulcanized	14.6 mm	160	DOL-3
10cD3	3	Threaded	M16	160	DOL-3

2.4 Steel plate-to-glulam lap joints

Steel plate-to-glulam lap joints were tested in 7 test series. All series but one comprised three nominally equal specimens. The actuator speed was 3 mm/min. The displacement recorded was the movement of the actuator. The steel plate-to-glulam tests are presented in Chapter 7.

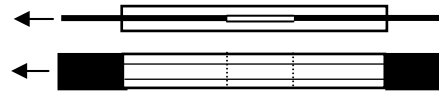
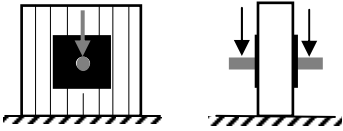
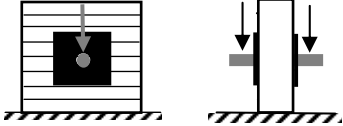
Series no	Type of bond	Lap length	Glulam, mm ³
11a	Nails 	160 mm	64x79x624 mm ³
11b	Glued rubber foil 	160 mm	64x79x624 mm ³
11c	Nails and glued rubber foil 	160 mm	64x79x624 mm ³
12	Glued rubber foil 	160 mm	2 x 25.5x79x624 mm ³
13	Glued rubber foil 	320 mm	2 x 25.5x79x944 mm ³
14a	Glued rubber foil 	150 mm	64x315x315 mm ³
14b	Glued rubber foil 	150 mm	64x315x315 mm ³

3. Test specimen manufacturing and materials, and testing locations

3.1 Manufacturing

The steel parts were supplied and prepared by project partner SFS Intec AB. The steel parts comprised various plates and threaded and smooth turned rods.

The rubber and the rubber foils (cloths/mats) were manufactured by Metso Minerals AB, Ersmark. Also the vulcanization of the rubber to the steel plates and rods were made by Metso Minerals.

The wood materials, glulam and LVL, were supplied by project partner Svenskt Limträ AB through Moelven Töreboda AB. The wood material and test specimen attachment parts needed for the the glued-in rods tests were prepared at Töreboda AB.

The procedure for gluing of the specimens is described in detail in a report: "High Capacity Rubber Type Joints Manufacturing of Full Scale Joints" (Wikström, 2006b), attached as an appendix in this report. The gluing was made in Töreboda by personnel from project partner Casco Products AB. The sulphuric acid rinse of the rubber surfaces was made at Casco Products AB, Stockholm. This company also supplied the glue and made a number of small scale tests of various rubber-glue combinations before choice of materials to be used in the present tests. Material property tests are reported in (Wikström, 2006a) and in (Björnsson and Danielsson, 2006).

3.2 Steel

The steel plates were made of steel quality SS-2132, with a nominal yield stress of 350 MPa. The rods were made of high strength steel with a nominal yield stress, defined as the "0.2% limit stress", higher than 800 MPa.

3.3 Wood materials

The glulam with cross section height 225 mm was of quality L40, all other glulam was of quality LK30. The average density and the moisture content at gluing of specimens and at testing was 465 kg/m³ and about 12%, respectively. The lamellae thickness was 45 mm, with exception of the 115x155 mm² cross sections, which had lamellae thickness 37.5+40+37.5 mm. The laminated veneer lumber, LVL, was of the make Kerto-Q, 27 mm thick and with 9 veneer layers out of which 2 are oriented with the grain direction perpendicular to the length of the specimen. The average moisture content was 11.3% and the density at this moisture content 470 kg/m³.

3.4 Rubber

The rubber was SBR (styrene-butadien) number 61 60 367. According to standardized ISO-tests, for this rubber the density is 1120 kg/m³, the hardness is 61° Shore A, the tensile strength is 21.6 MPa and the elongation at break is 644 %. Hardness 61° Shore corresponds approximately to shear modulus $G \approx 1.2$ MPa. The thickness of the foil used when glueing wood-to-wood was 1.3-1.5 mm. The foil was delivered in reels with 50 cm width of the foil. The thickness of the rubber layer vulcanized to steel was 1.0-1.2 mm.

3.5 Glue

The two qualities of glue used were both of the type 2-component polyurethane, PUR. The glues are specified in the below table:

Test series	Adherends	Glue
1-3	Glulam - glulam	SikaForce 7710 + hardener 7020
4-5	LVL - glulam	SikaForce 7710 + hardener 7020 (+nails)
6-10 a	Smooth steel - glulam	SikaForce 7710 + hardener 7020
6-10 b	Vulcanized steel - glulam	SikaForce 7710 + hardener 7020
6-10 c	Threaded steel - glulam	Purbond CR 421 (glue+hardener)
11a	Smooth steel - glulam	No glue. (Teflon+nails)
11b	Vulcanized steel - glulam	SikaForce 7710 + hardener 7020
11c	Vulcanized steel - glulam	Purbond CR 421 (glue+hardener) (+nails)
12-14	Vulcanized steel - glulam	SikaForce 7710 + hardener 7020

3.6 Nails and Teflon

The nails used are specified in following sections together with the geometry of the various specimens. The Teflon sheets used in tests 11a were supplied by Analyscentrum, Stockholm.

3.7 Testing locations

Most of the tests were carried out in the structural engineering and the structural mechanics laboratories at LTH, Lund University, Lund. Test series 4 and 5 (LVL) and a few of the glued-in rod tests were carried out at SP, Borås. The long duration of load tests of glued-in rods were made at a testing site in Asa, Småland.

4. Glulam-to-glulam joints

4.1 Test series 1a, single lap joint in flatwise bending

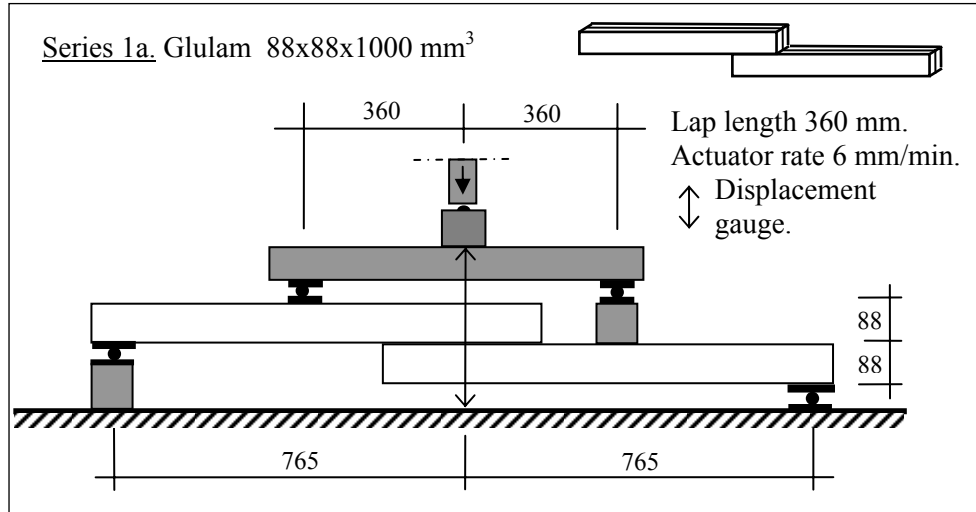

3 nominally equal specimens were tested. Specimen geometry, lamellae orientation, test setup and the speed of the loading actuator are indicated in the above figure. Load and displacement were recorded.

The flatwise bending test is hard, exposing the rubber foil to high tensile normal stress and cleavage perpendicular to the bond area and not allowing the beneficial shear flexibility of the rubber layer to be activated.

The test results are presented in the below table, pictures and diagram. The tests results seem good. Bond area fracture was obtained only at high load. In two of the three tests was failure initiated by fracture in the wood, not within and neither in the close vicinity, of bond surface. The bending stress at failure indicated in the table is calculated as $\sigma_f = M_f / (bd^2/6)$, where M_f is the bending moment at failure and $b=d=88$ mm. The value of σ_f for a solid wood or glulam beam sawn to the same geometry as the tested beams can by use of equations and material parameter values given in (Gustafsson and Enquist, 1988) be estimated to be the order of 15-20 MPa.

Test no.	P_f kN	δ_f mm	σ_f MPa	Cause of failure
I	22.7	15.4	40.4	Fracture in the rubber foil surface, at the rubber-glu interface
II	12.7	9.9	22.7	Perp. to grain tensile fracture in the wood, ~1-2 cm from the bond surface
III	18.9	12.9	33.6	Perp. to grain tensile fracture in the wood, ~1-2 cm from the bond surface



Series 1a, single lap joint in flatwise bending

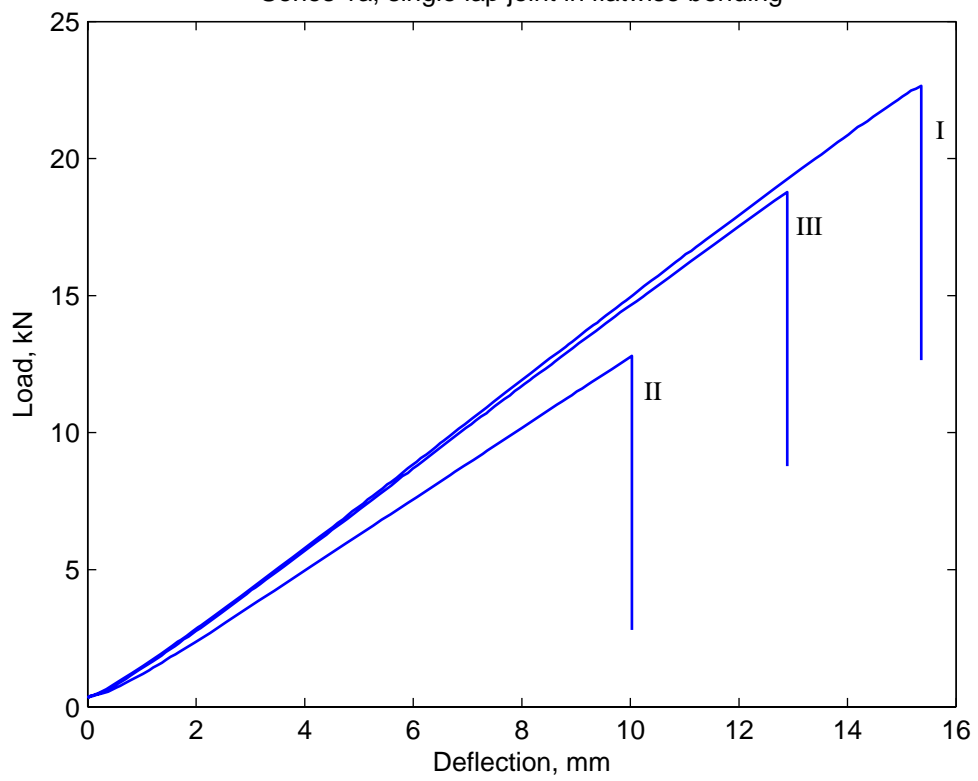



4.2 Test series 1b, single lap joint in edgewise bending

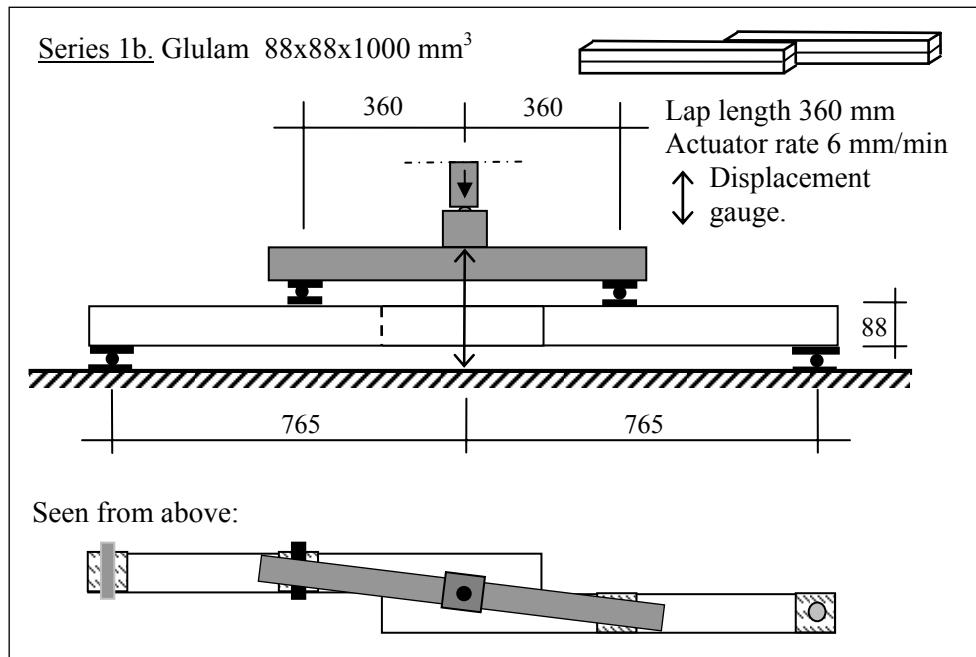

The single overlap edgewise bending test could also be named a single bond area torsion test. Failure developed in all three tests in the wood in the overlap region. These wood failures seemed to be caused by rolling shear, longitudinal shear and perpendicular to grain tensile stress in the wood. No fracture was observed in the bond area. Small rolling shear cracks in the wood close to the corners of the bond area were observed well before maximum load. The course of failure had a somewhat more ductile character than the flatwise bending test failures and some crackling could be heard before the final failure. In the below table is σ_f the magnitude of the bending stress at failure, i.e. $M_{failure}/(bh^2/6)$, where M is the cross section bending moment and $b=h=88$ mm.

Test no.	P_f kN	δ_f mm	σ_f MPa	Cause of failure
I	19.0	19.2	33.9	Fracture in the wood: rolling shear, longitudinal shear and perp. to grain tension.
II	21.2	19.8	37.8	Fracture in the wood: rolling shear, longitudinal shear and perp. to grain tension.
III	22.6	17.8	40.3	Fracture in the wood: rolling shear.

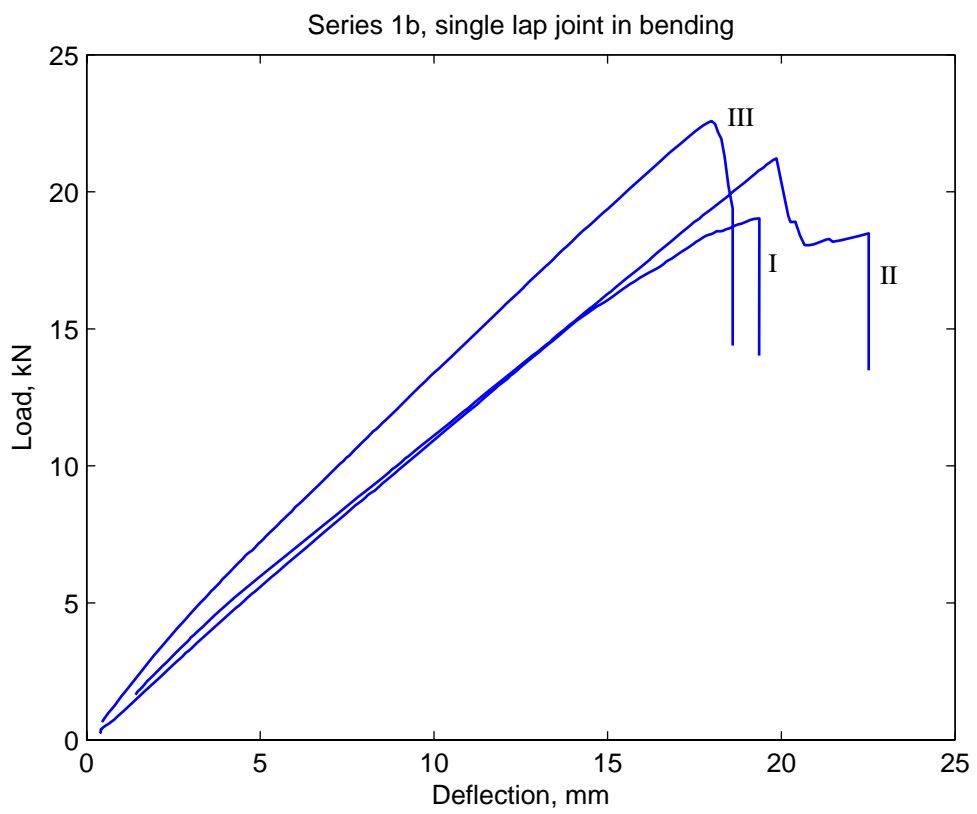



4.3 Test series 2, single lap joint in rolling shear

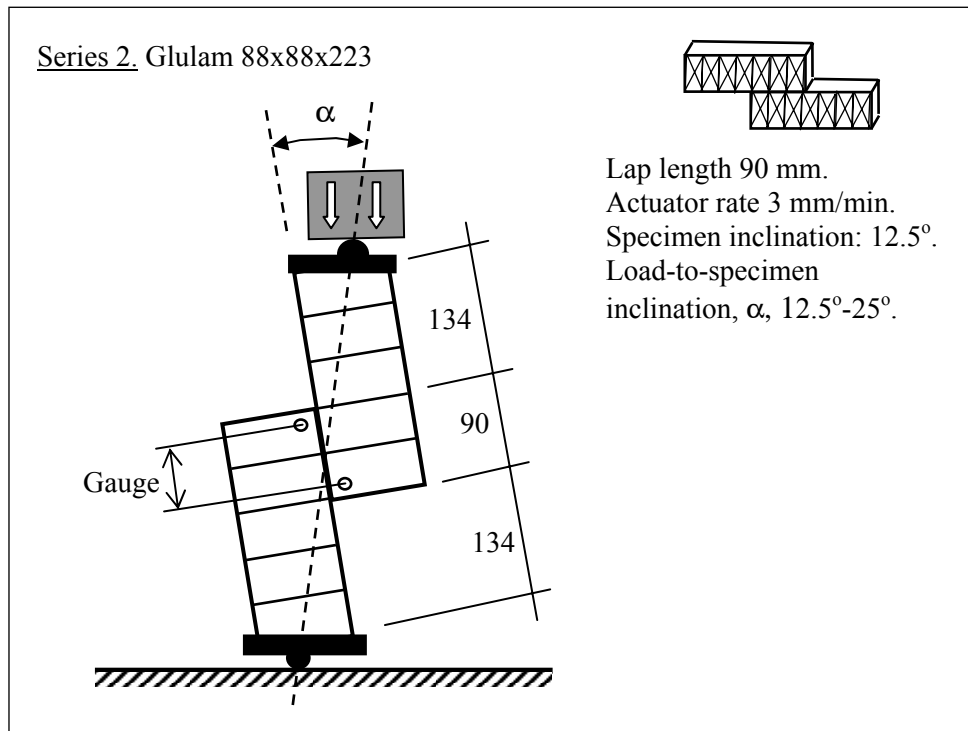

Rolling shear failure was not obtained due to poor loading setup design. Instead failure developed as a perpendicular to grain tension bending failure. Although the load-to-specimen angle was increased in tests II and III, the same kind failure occurred in all three tests. The recorded load indicated in the below table and diagram is the vertical component of the total load. The numbers indicated in the τ_f -column show the bond area mean shear stress at failure, i.e. the tangential force at failure divided by the bond area. σ_f is the tensile bending stress at failure as calculated by the conventional Navier's bending stress equation.

Test no.	P_f kN	δ_f mm	α	τ_f MPa	σ_f MPa
I	12.9	0.91	12.5°	>1.6	2.1
II	15.2	1.35	~20°	>1.8	2.5
III	16.7	1.61	~25°	>2.1	2.6



Series 2, rolling shear

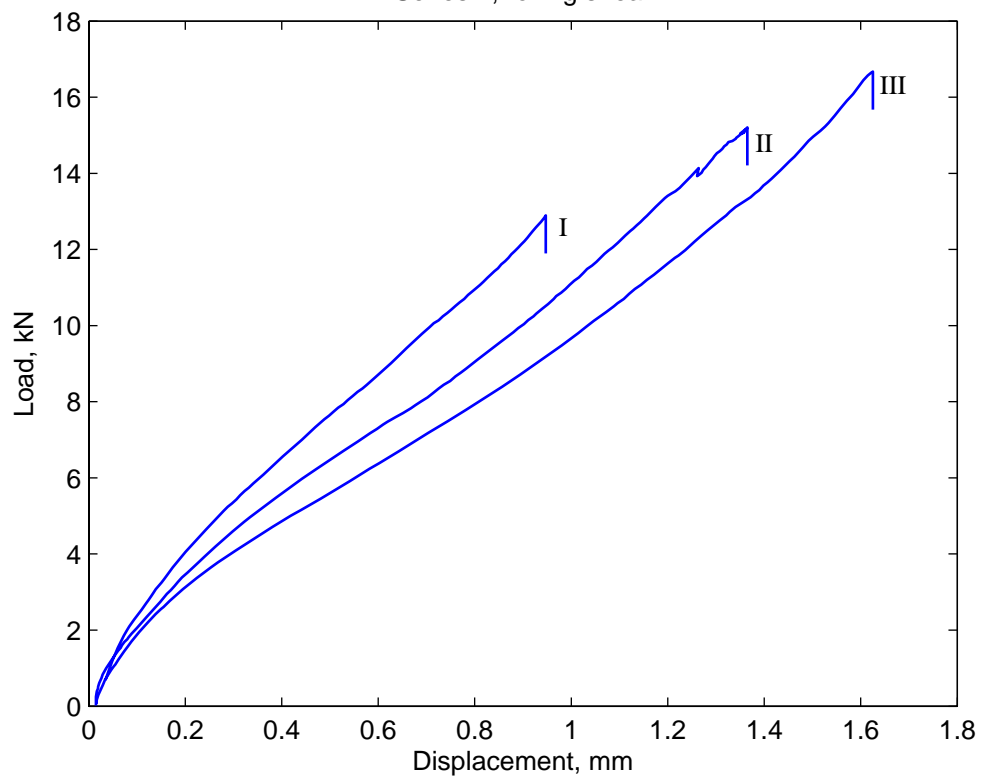

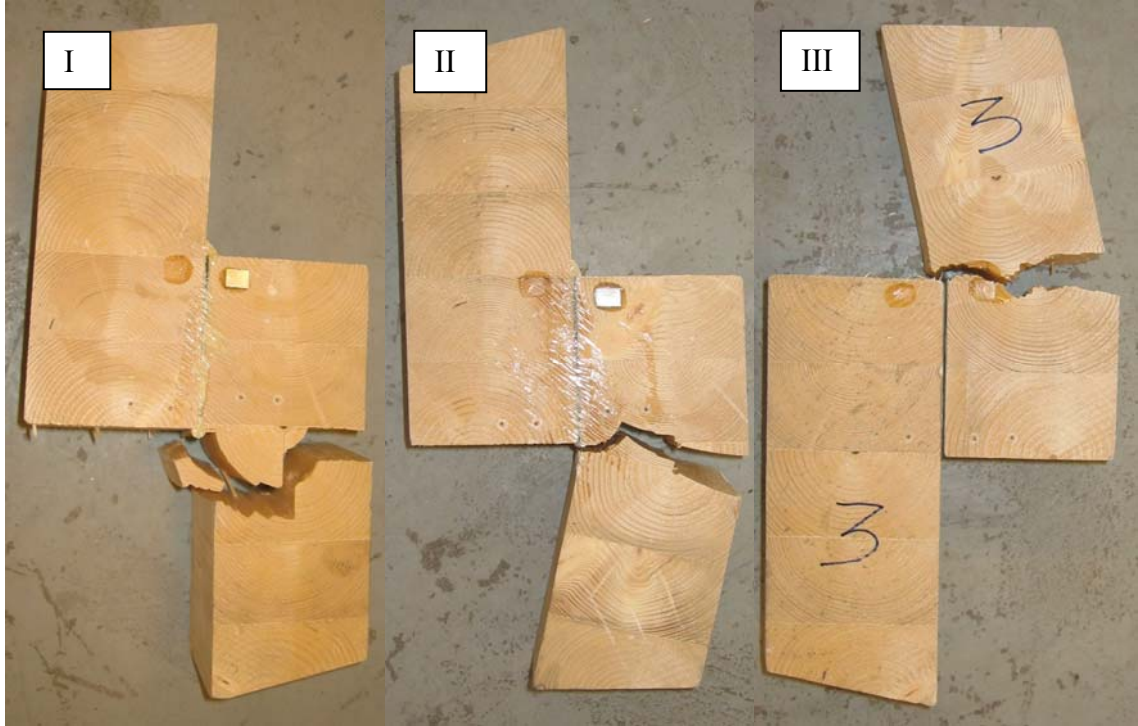

4.4 Test series 3a, 300 mm double lap joint in bending

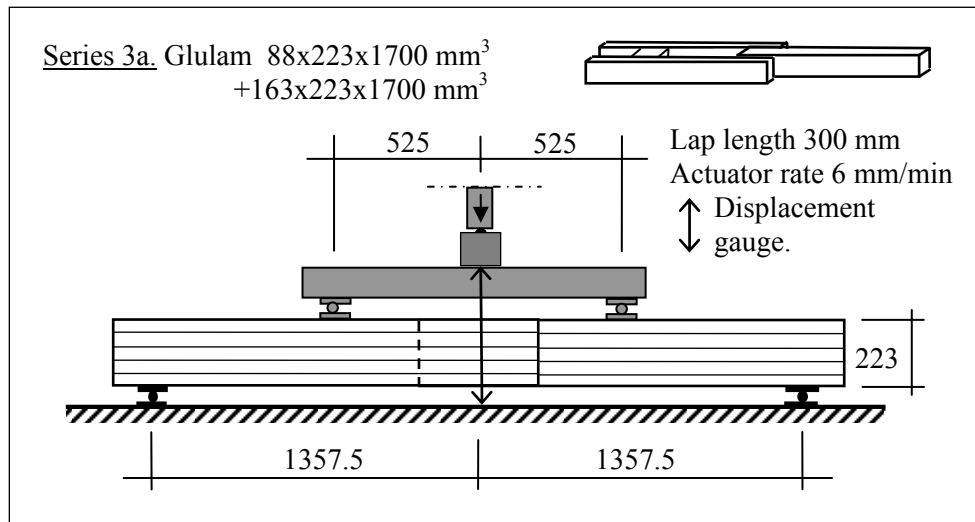

Fracture in the wood started well before ultimate load was reached, starting with development of 45° inclined rolling shear stress cracks in the wood at the corners of the bond area. The development of these first cracks had no or insignificant influence on the recorded load versus displacement performance. Significant crackling and development of a number of fairly small cracks in the wood was observed before final failure. The final failure seemed to include the development of large longitudinal shear, rolling shear and perpendicular to grain tensile cracks in the bulk part of the wood members and also rolling shear cracks in the wood in the vicinity of the bond area. After failure was moreover shear fracture in the rubber-to-wood interface observed at some locations. In the below table is σ_f the nominal bending stress in the middle wooden member at failure.

Test no.	P_f kN	δ_f mm	σ_f MPa	Estimated predominant cause of failure
I	63.6	27.3	19.6	Combined rolling shear, longitudinal shear and perp. to grain tension in the wood.
II	68.4	26.0	21.1	Combined rolling shear, longitudinal shear and perp. to grain tension in the wood.
III	70.9	29.3	21.8	Combined rolling shear, longitudinal shear and perp. to grain tension in the wood.



III at ~80% of failure load



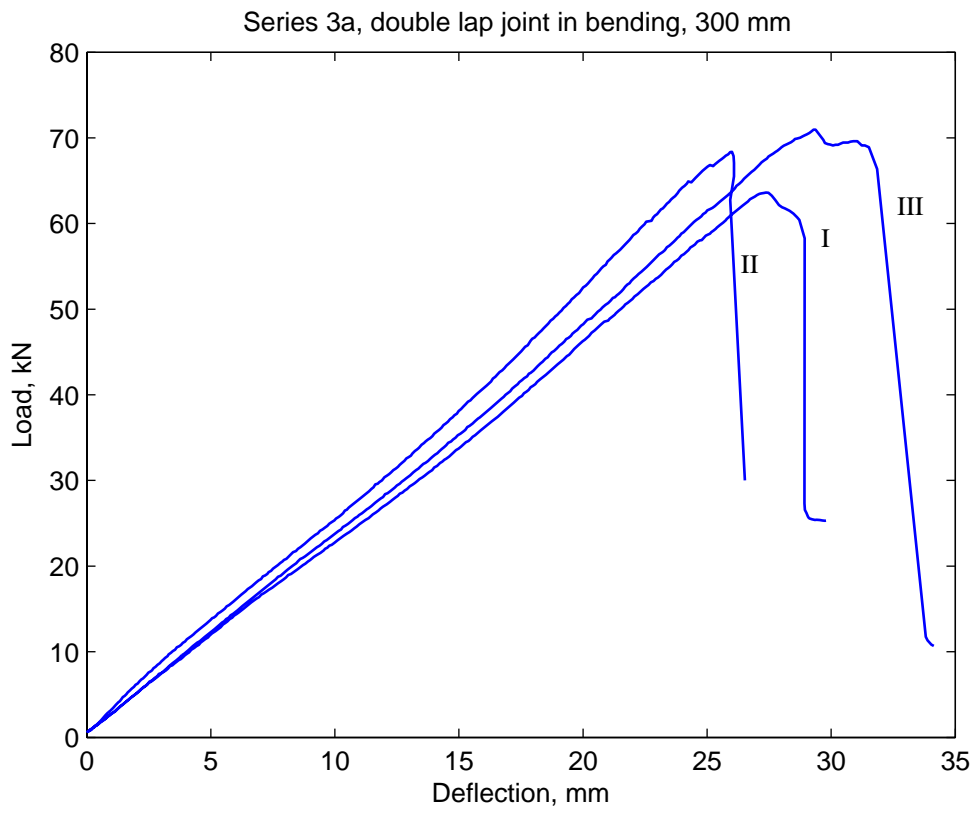

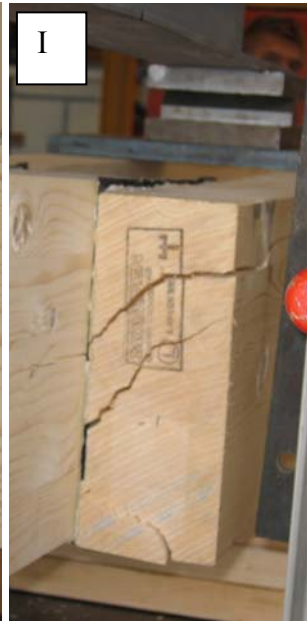

4.5 Test series 3b, 600 mm double lap joint in bending

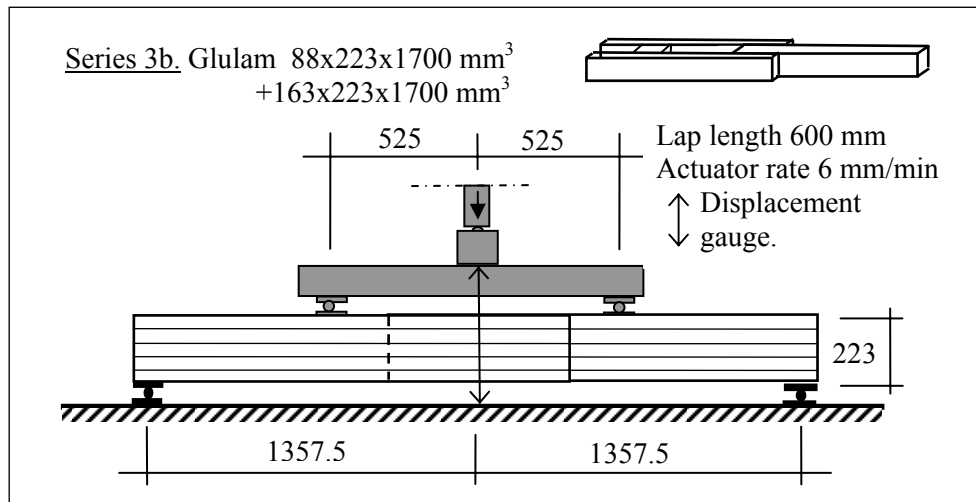

The 600 mm double overlap bending specimens showed, - just as the corresponding 300 mm specimens - , development of 45° inclined rolling shear stress cracks in the wood at the corners of the bond area well before peak load. The development of these first cracks had no or insignificant influence on the recorded load versus displacement performance. The course of final failure was more abrupt than for the 300 mm specimens. Also the failure loads and the beam stiffness were significantly higher. In the below table is σ_f the nominal bending stress in the middle wooden member at failure.

Test no.	P_f kN	δ_f mm	σ_f MPa	Estimated predominant cause of failure
I	139.3	40.1	42.8	Longitudinal shear and rolling shear in wood
II	137.2	39.8	42.3	Bending failure of wood
III	127.8	37.0	39.3	Longitudinal shear in wood.

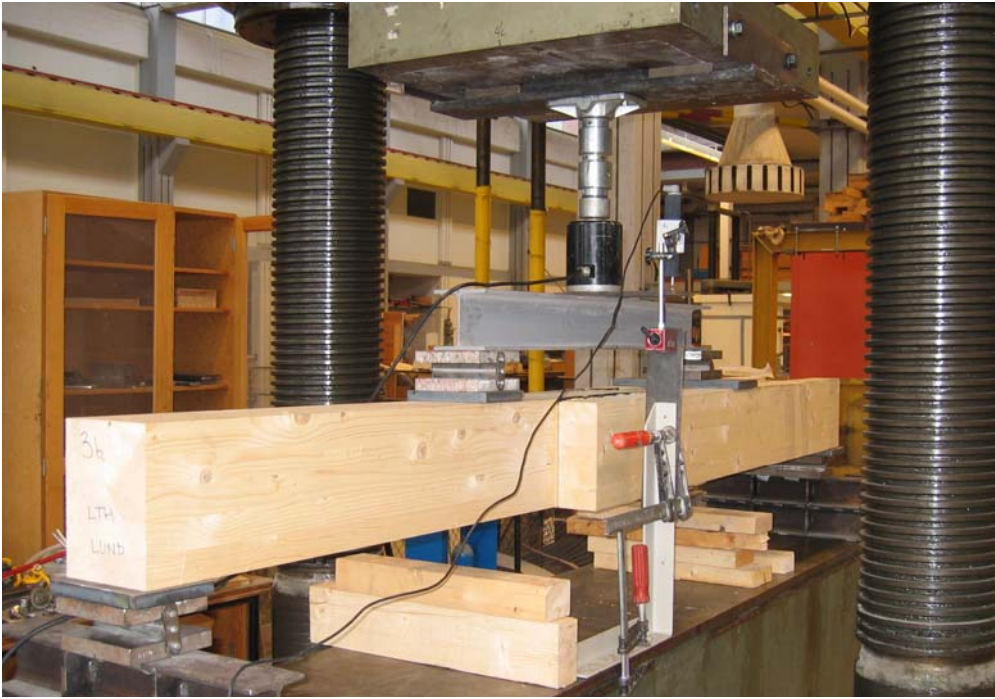

Series 4b, double lap joint in bending, 600 mm

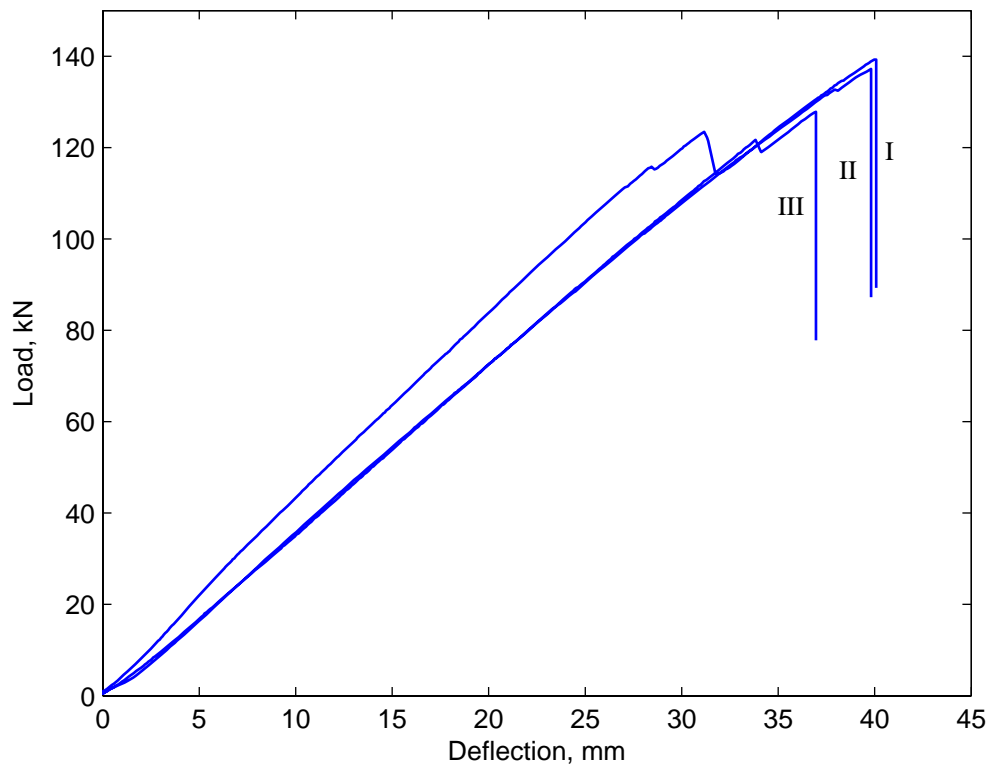

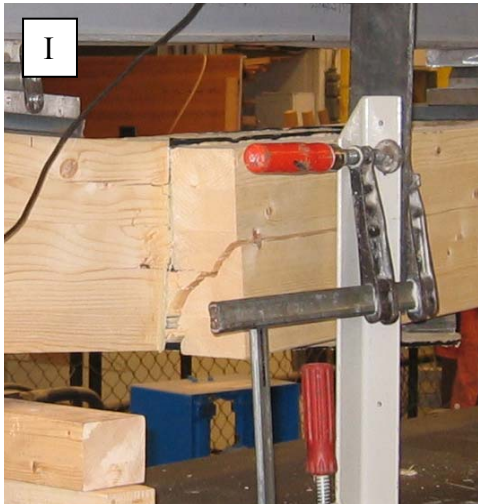
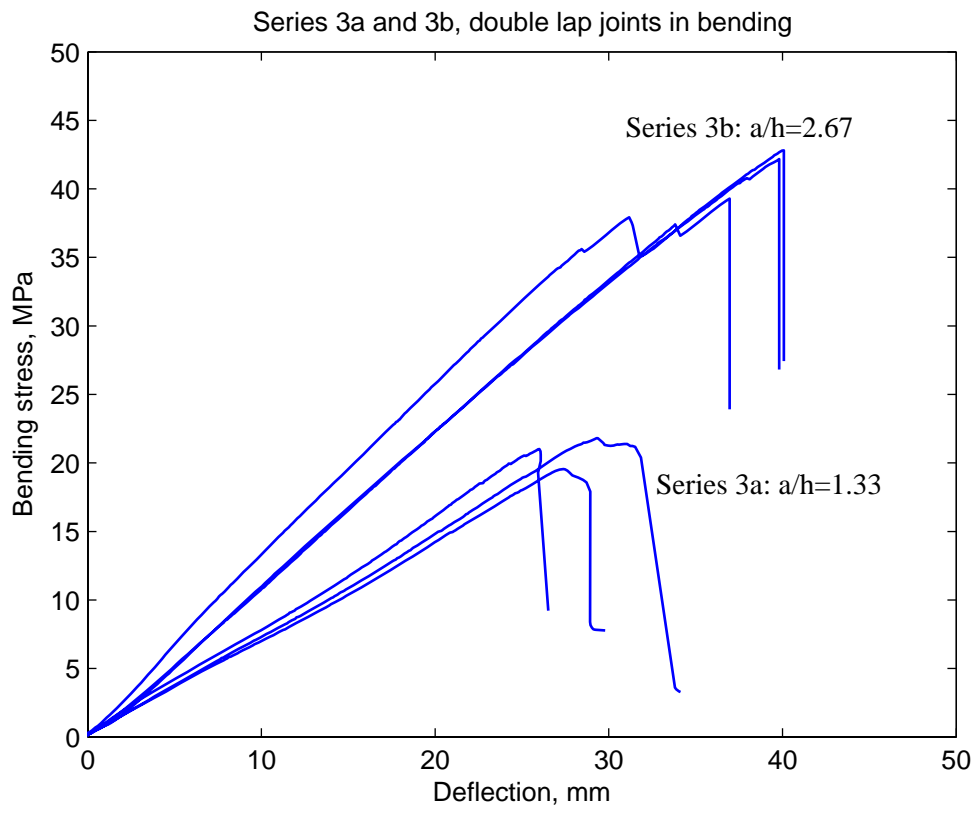

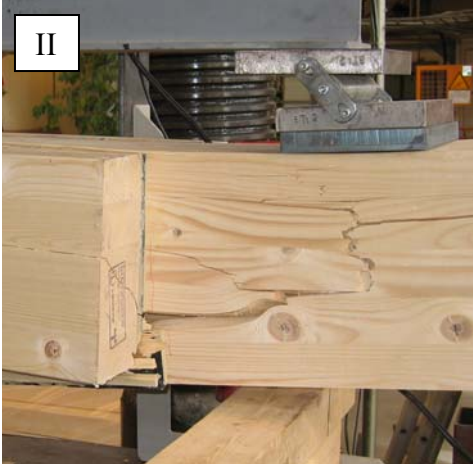

4.6 Test series 3c, 600 mm double lap joint in shear

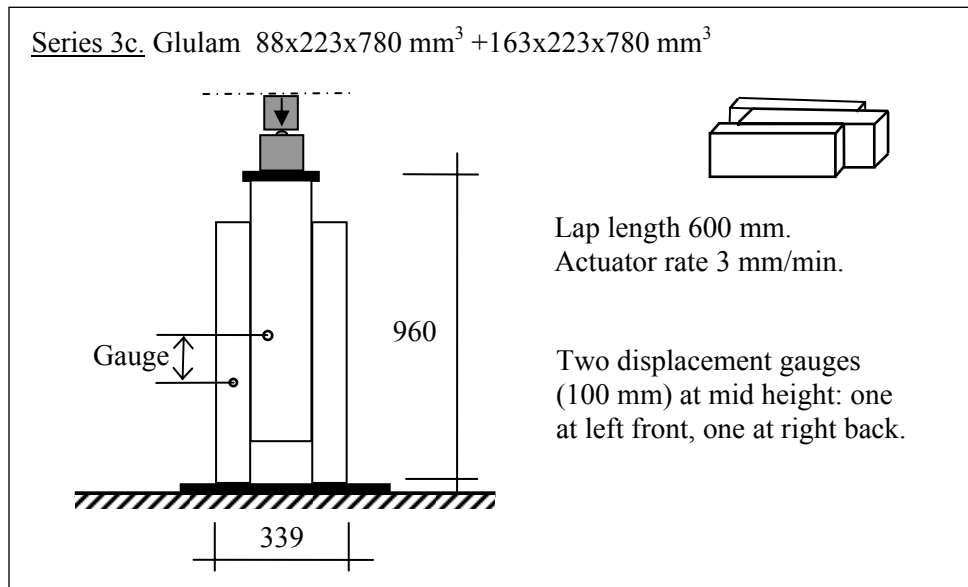

The shear test specimen joints had the same geometry as the 600 mm double lap bending test specimens. Development of a small perpendicular to grain tensile crack in the middle of the lower end of the mid wooden element started at about 50% of the ultimate load. This happened for all three specimens, but it didn't seem to influence the performance of the joint. The final failures were sudden and involved a loud bang due to the high loads at failure. In the below table is τ_f the average bond area shear stress at failure, i.e. $\tau_f = P_f / (2ba)$, where $b = 223 \text{ mm}$ and $a = 600 \text{ mm}$ and σ_f is the compressive parallel to fiber normal stress at failure, i.e. $\sigma_f = P_f / (bh)$, where $h = 163 \text{ mm}$.

Test no.	P_f kN	δ_f mm	τ_f MPa	σ_f MPa	Cause of failure
I	1227	4.11	4.58	33.8	Shear failure in the wood along the bond area.
II	1188	3.77	4.44	32.7	Compressive bending failure of the wood.
III	1109	2.48	4.14	30.5	Shear failure in the wood perpendicular to and along part of the bond area, possibly due to non-uniform contact between the specimen and the supporting steel plate.

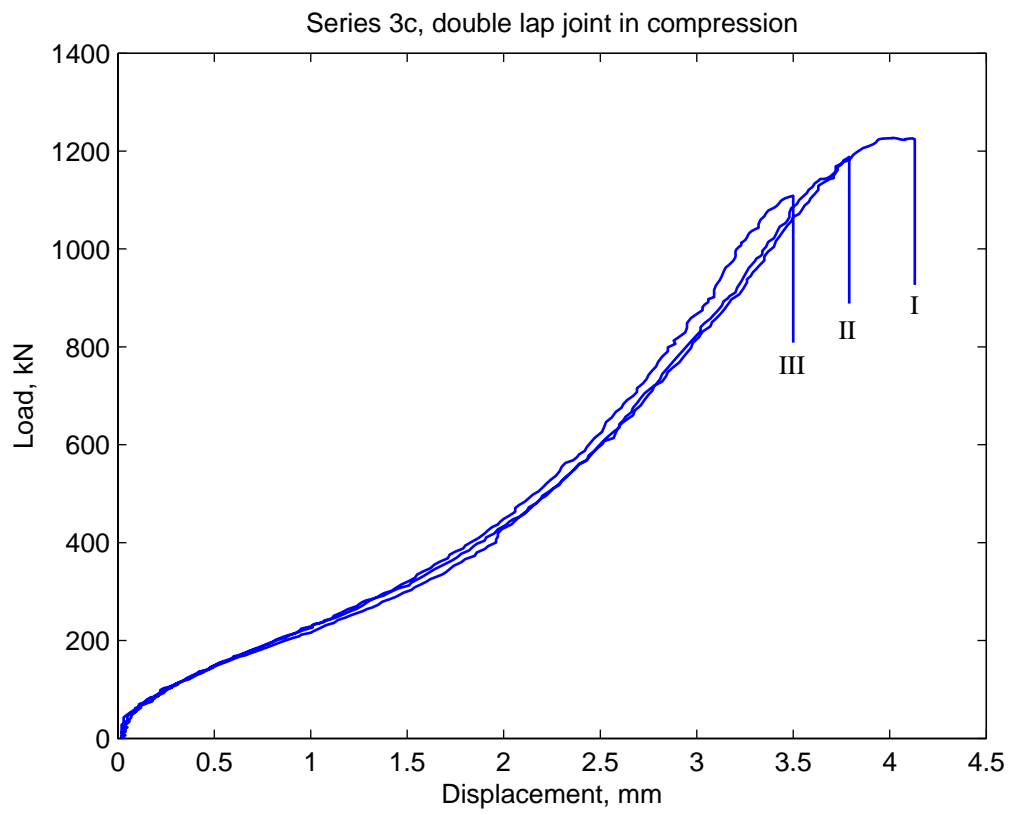



5. LVL-to-glulam joints

LVL-to-glulam lap joints were tested in the three series. The bonds were nailed rubber foil adhesive joints. The nails were anchor nails and gave pressure during hardening of the adhesive. In each series three nominally equal specimens were tested. The LVL was of the brand, type and thickness "Kerto Q, 27 mm". The speed of loading actuators was set to 3 mm/min.

The tests in series 4a and 4b were made by use of equipment for testing the tensile strength of boards. In this equipment the load is applied by means of hydraulic grips that squeeze and pull at the ends of the specimen.

5.1 Test series 4a, 160 mm lap joints in shear by tensile loading

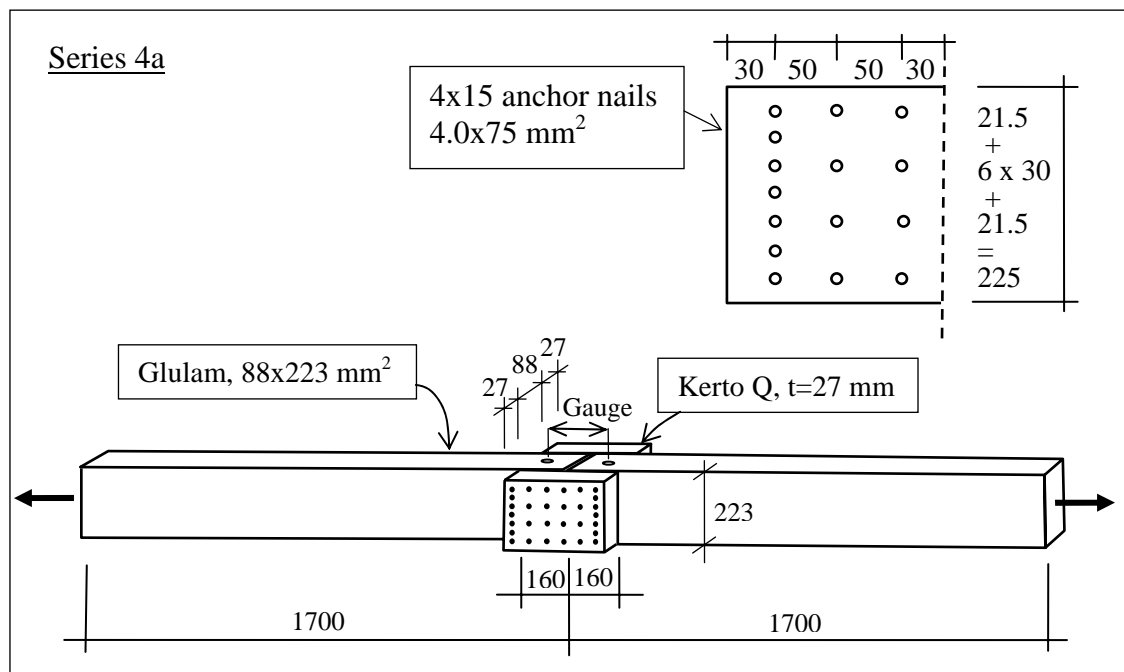

The test results are indicated in the below table, diagram and pictures. The notations used for type of failure is defined in the below figure. σ_f indicates the mean tensile stress in the LVL at failure.

Test no.	P_f kN	δ_f mm	τ_f MPa	σ_f MPa	Failure, "left"	Failure, "right"
I	202.4	6.25	2.84	16.7	Shear-KL	Shear-KQ
II	212.8	6.72	2.99	17.5	Shear-KL	Shear-KL
III	203.9	6.28	2.86	16.8	Shear-KL	Shear-KL

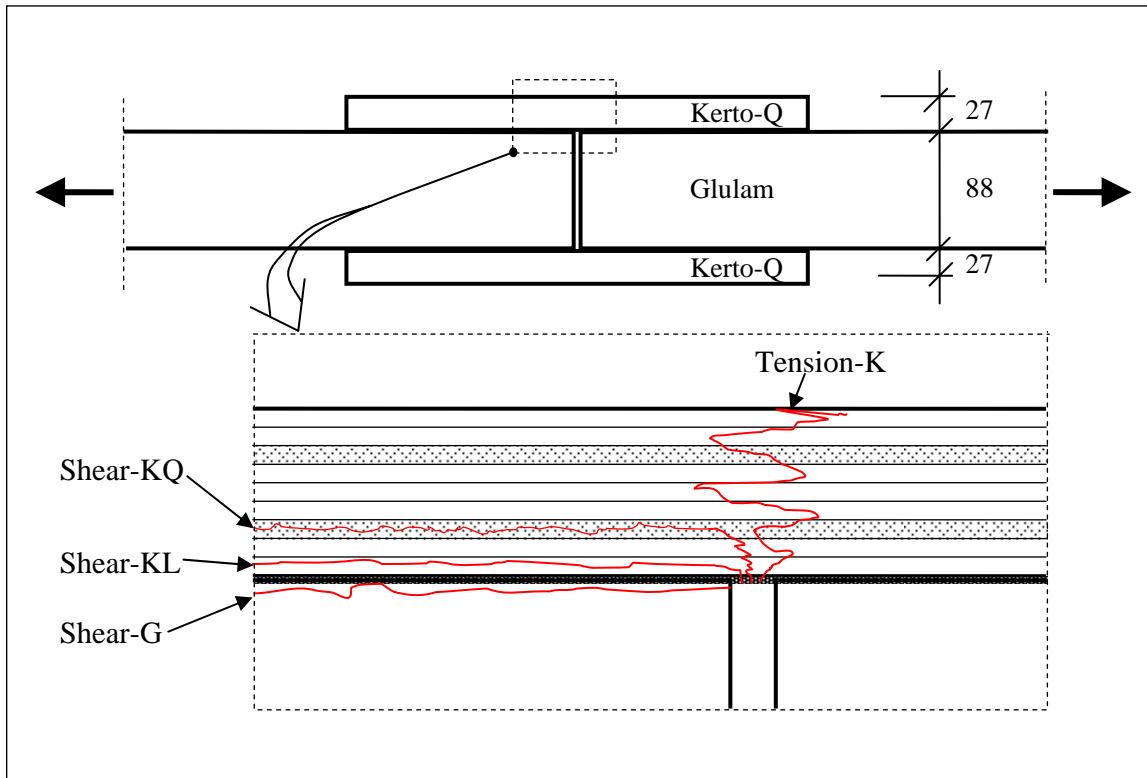

Various conceivable failure locations are illustrated in the above figure. "Tension-K" is tensile rupture of the LVL (the Kerto), "Shear-KQ" is rolling shear fracture in the inner-most veneer layer with fiber orientation in the cross-direction, "Shear-KL" is shear fracture in the inner-most veneer layers with fiber orientation along in the direction of the global load, and "Shear-G" is shear fracture in the glulam. Failure of the rubber layer or the in the adhesive interfaces was not observed to be dominating for any of the specimens tested in Series 4a. Adhesive interface fracture was observed locally when "Shear-KQ" or "Shear-G" was predominant.

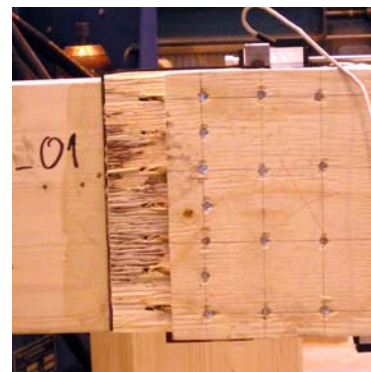
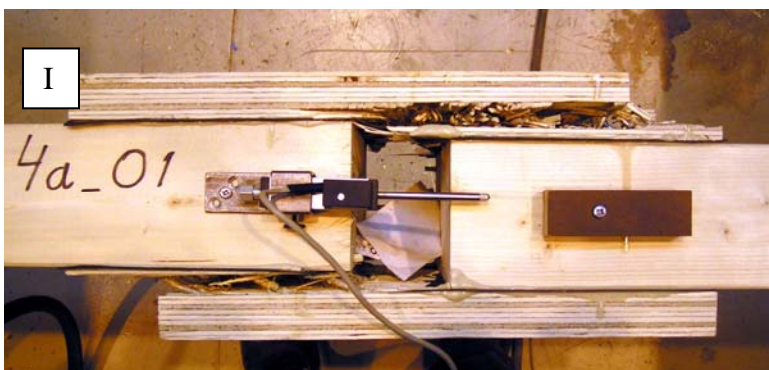

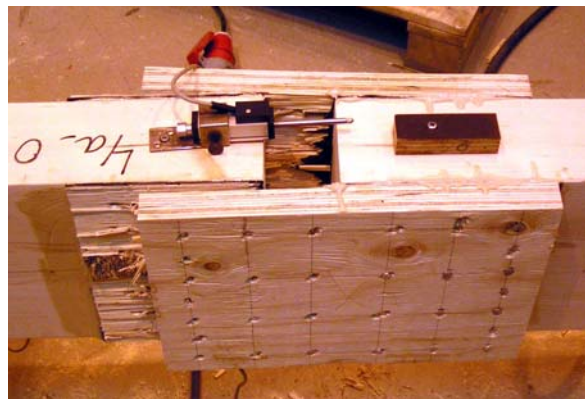
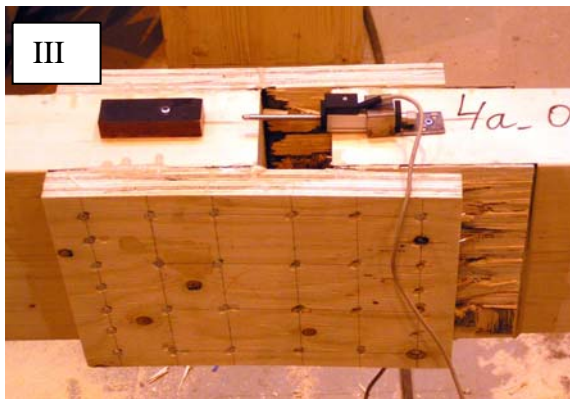
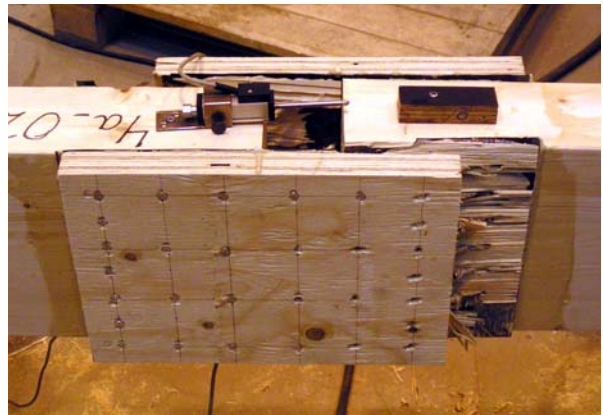
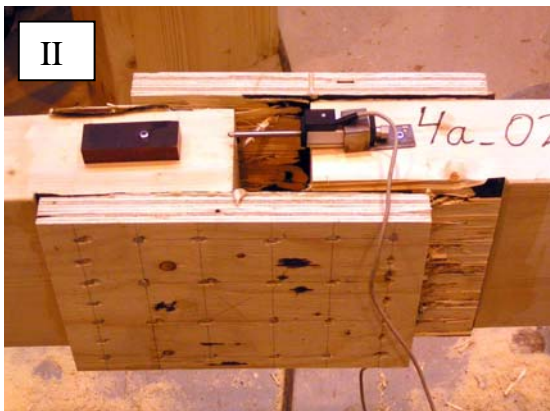
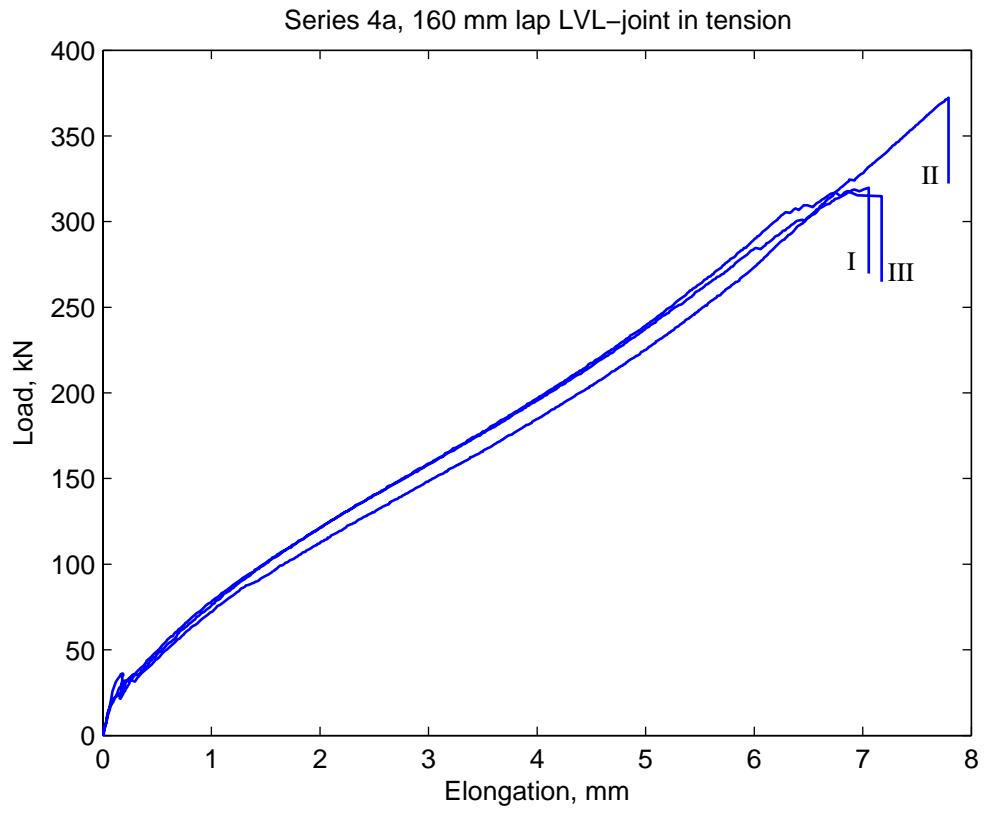

5.2 Test series 4b, 320 mm lap joints in shear by tensile loading

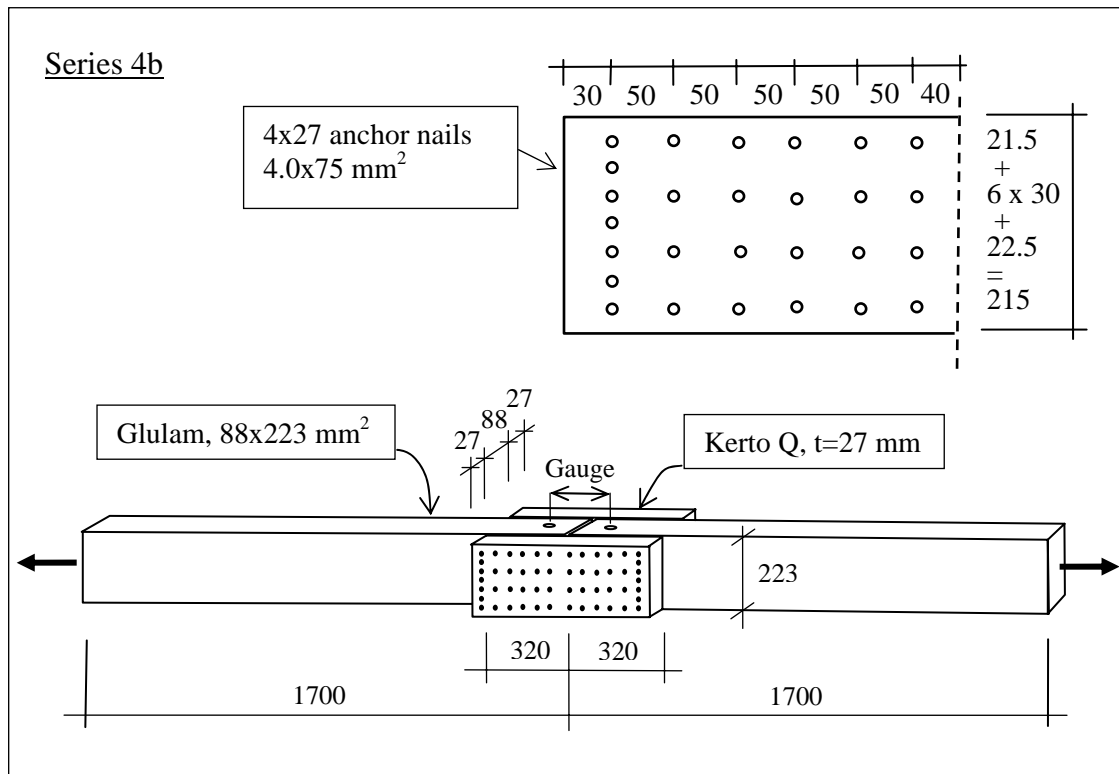

The test results are indicated in the below table, diagram and pictures. The failure mode notation given in the below table are defined in section 5.1. σ_f indicates the mean tensile stress in the LVL at failure.

In addition to the three specimens with a glued rubber foil and nails was one specimen without the rubber foil manufactured and tested. This additional specimen was nailed and glued in the same way as the other specimens, but without the rubber foil.

Test no.	P_f kN	δ_f mm	τ_f MPa	σ_f MPa	Failure, failure area 1	Failure, failure area 2
I	372	7.79	2.61	30.6	Tension-K	Shear-KQ
II	320	7.05	2.24	26.3	Tension-K	Tension-K
III	315	7.17	2.21	25.9	Shear-KQ	Shear-KQ
No foil	268	0.77	1.88	22.0	Shear-KL	Shear-KL

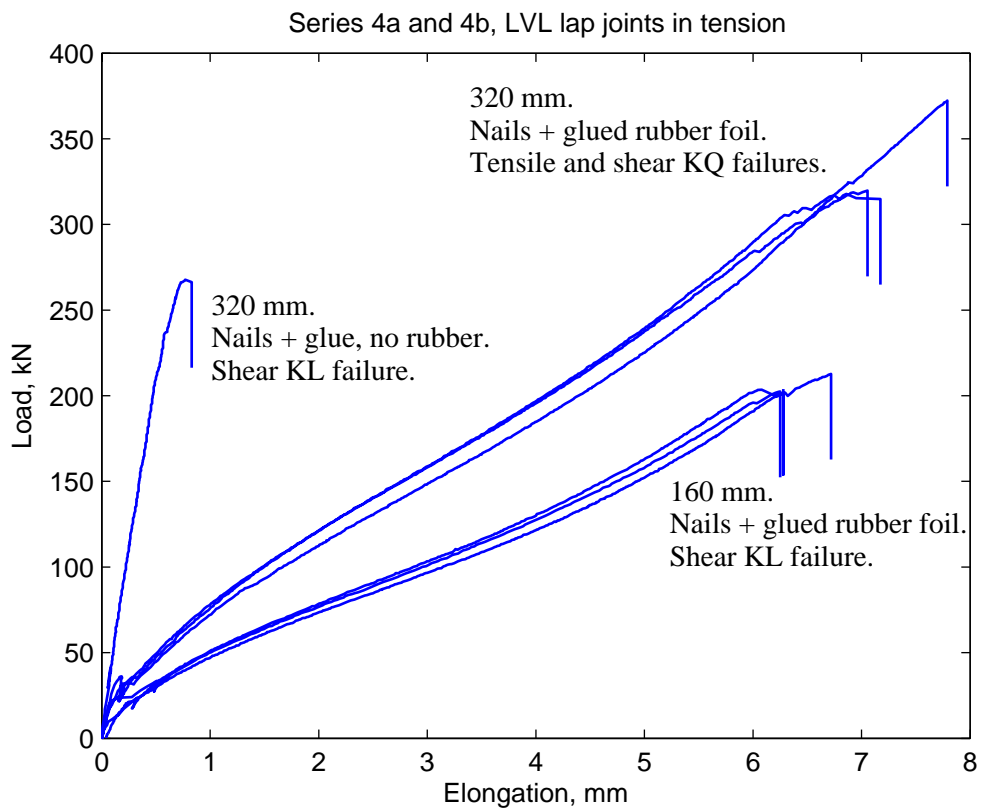
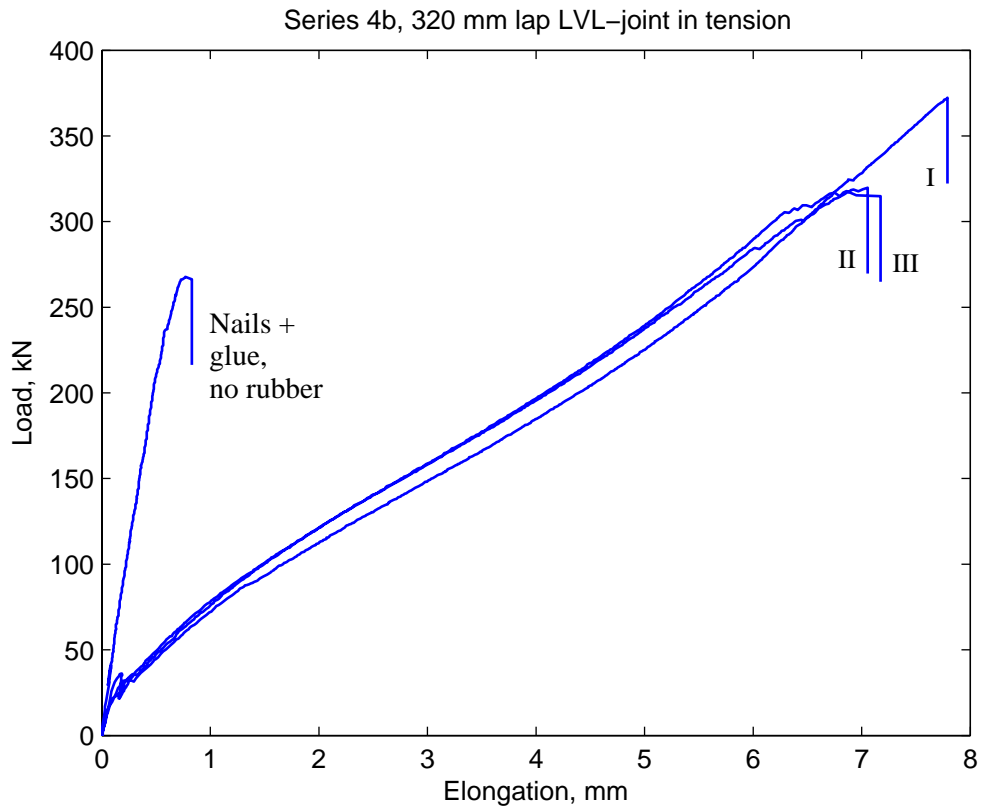

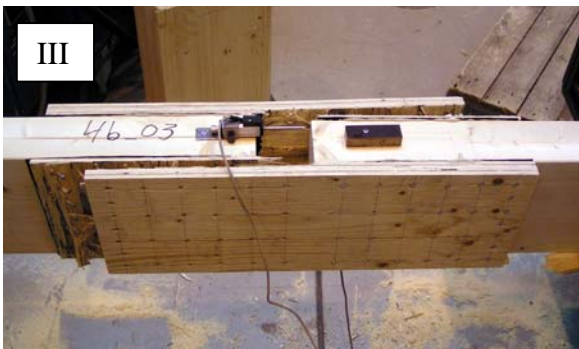
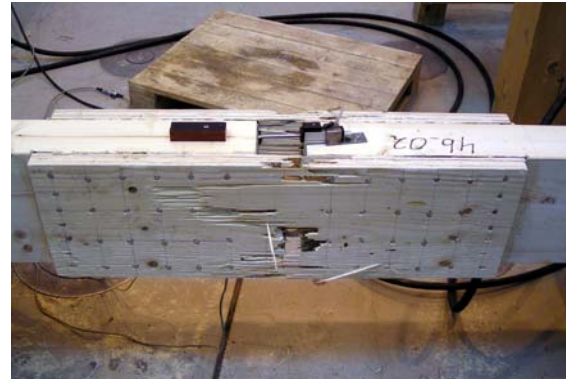
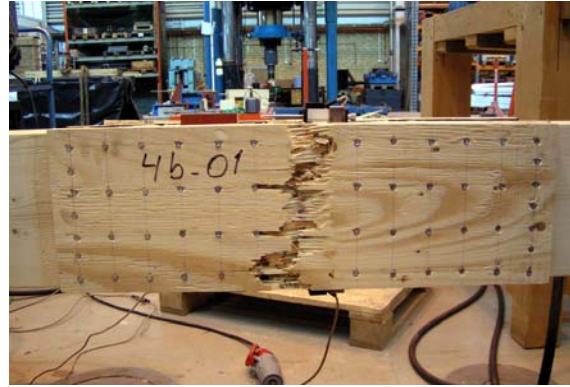
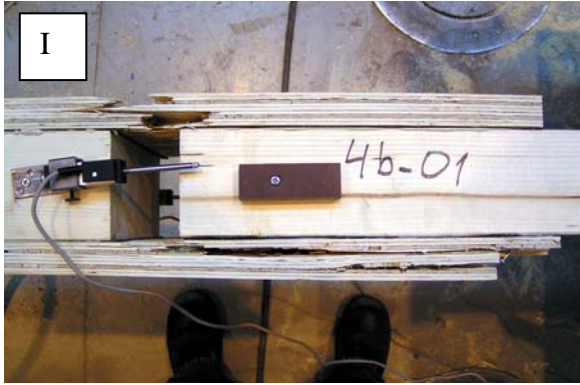

5.3 Test series 5, 160 mm lap joint in perpendicular tension

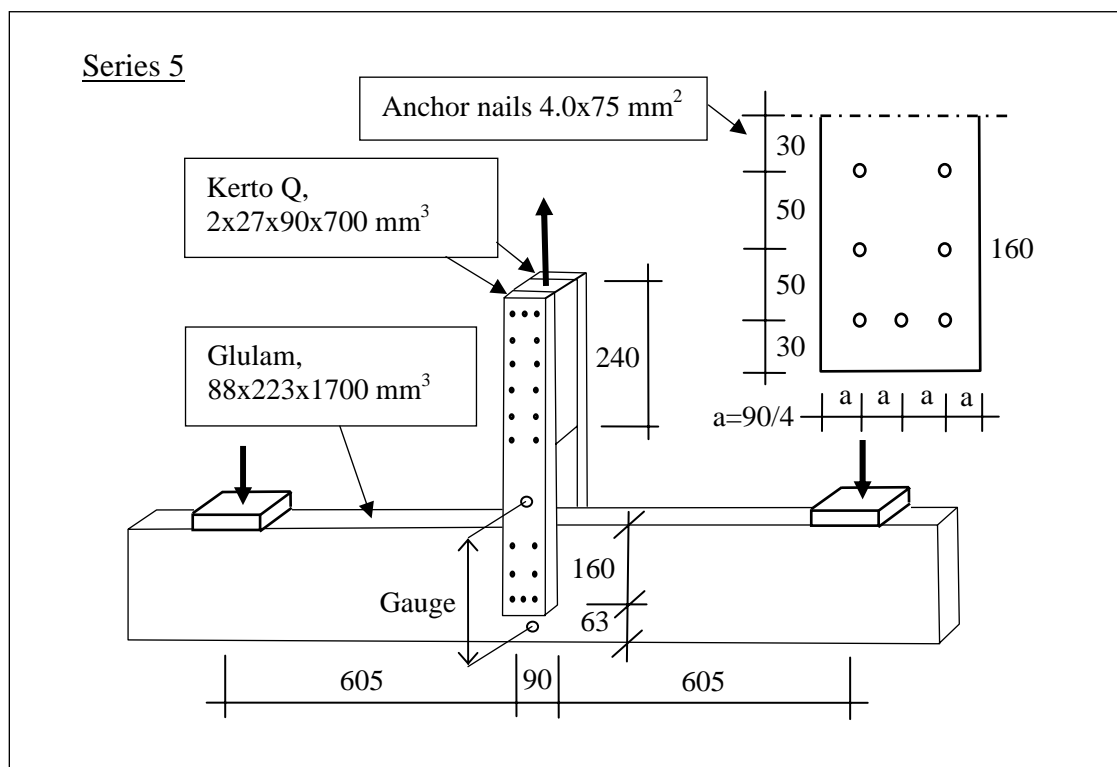

The test results are indicated in the below table, diagram and pictures. The shear stress is the mean shear stress across the bond areas at failure, i.e. $P/(2xLxb)$, where $L=160$ mm and $b=90$ mm.

During test number II it was found that glue was missing in one of the rubber-LVL interfaces. The results obtained by specimen II are thus not valid for a symmetric specimen, having both LVL-parts glued to the rubber.

Test no.	P_f kN	δ_f mm	τ_f MPa	Failure, failure area 1	Failure, failure area 2
I	62.7	3.6	2.18	Longitudinal shear in LVL + rolling shear in glulam (+ Perp. to grain failure in beam.).	No failure. (Minor perp. to grain tensile failure at upper edge of beam.)
(II)	(47.2)	(15.1)	(1.64)	Glue missing.	Shear and tension-bending failure in LVL.
III	71.6	6.2	2.49	Longitudinal shear in LVL + perp. to grain failure in beam.	Longitudinal shear in LVL + perp. to grain failure in beam.

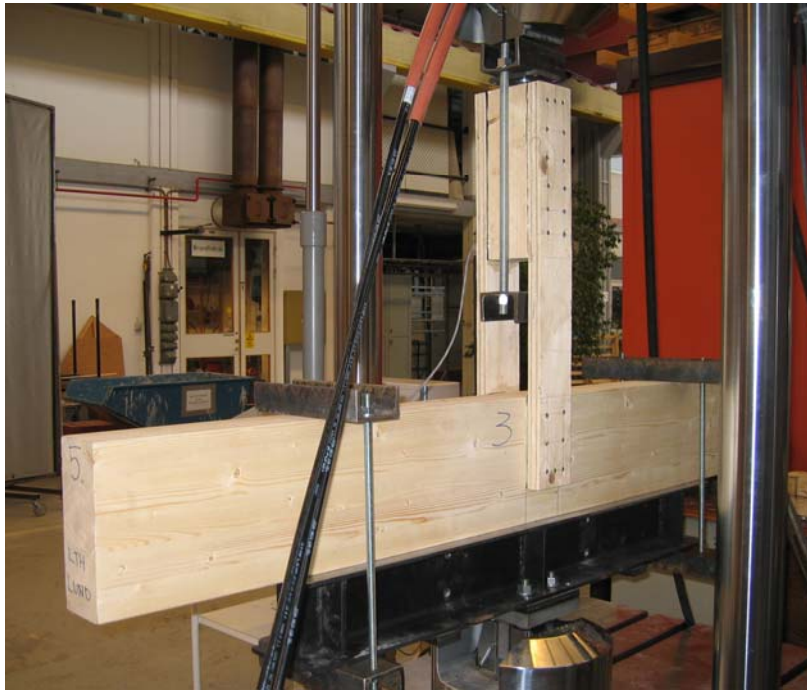

Series 5, 160 mm LVL lap joints in perpendicular tension

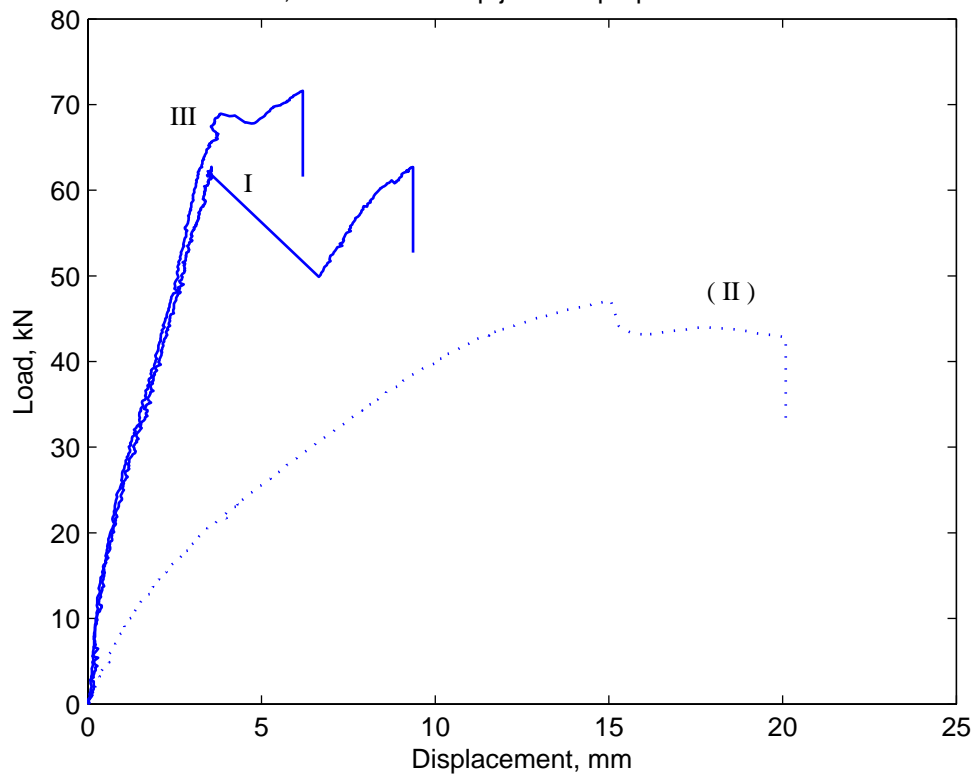

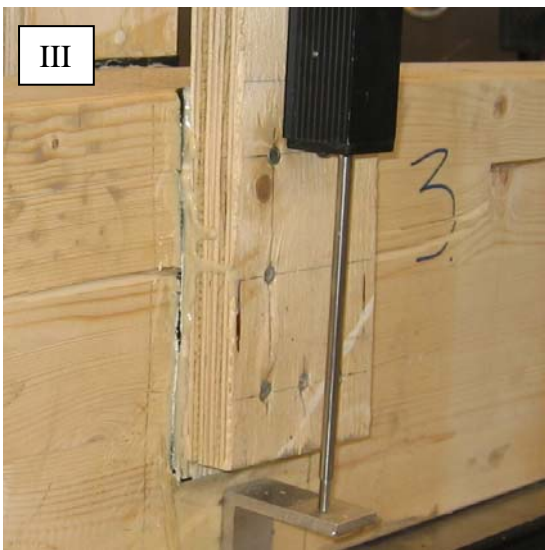
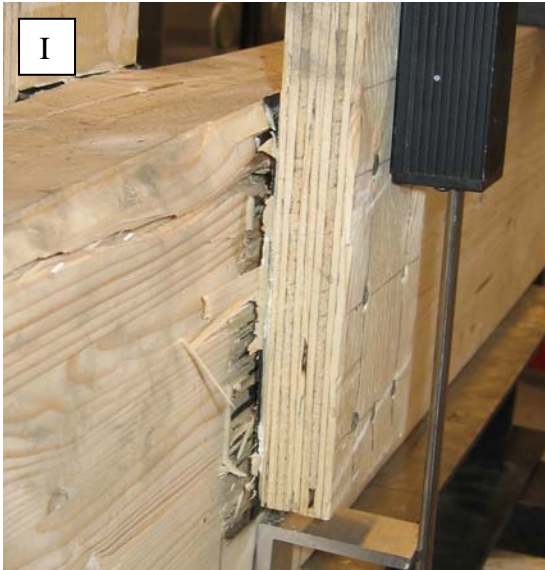

6. Glued-in steel rods

6.1 Shaping of specimens

The geometry of the glued-in steel rod specimens is shown below. The tested rod is the upper rod. In initial tests it was found that the lower support rod in some cases was poorly glued. Therefore the support end of the specimens in series denoted a and b were completed with nailing plates as shown in the right hand side of the figure.

The test series numbers, specimen dimensions and the number of tests are indicated in the below table. Three types of bonding and rod surfaces were tested:

- smooth steel rods glued to the wood,
- rubber vulcanized smooth steel rods glued to the wood, and
- threaded steel rods glued to the wood.

The rod diameters for b) indicated in the table show that the thickness of the rubber was about 1.1 mm.

The actuator speeds at ramp loading was such that the time to failure became 4-8 minutes. The magnitudes of the constant loads applied at the duration of load (DOL) tests are given in section 6.3.

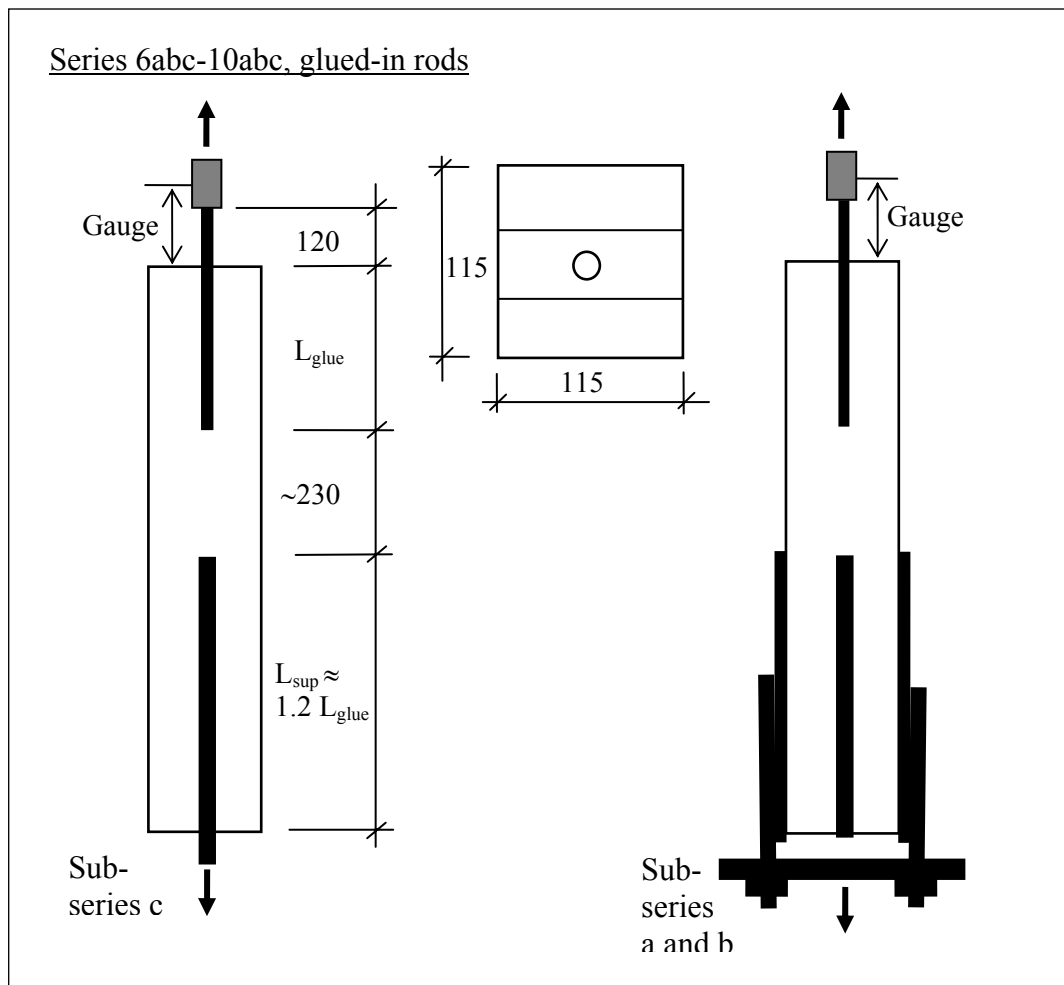

Series	N.o.s.	Rod surface	Diameter of steel / rod / hole, mm	L _{glue} , mm	Loading
6a	4	Smooth	18.3 / 18.3 / 20	160	Ramp
6b	4	Vulcanized	18.3 / 20.5 / 21	160	Ramp
6c	4	Threaded	M20 / M20 / 21	160	Ramp
7a	4	Smooth	18.3 / 18.3 / 20	320	Ramp
7b	4	Vulcanized	18.3 / 20.5 / 21	320	Ramp
8a	4	Smooth	18.3 / 18.3 / 20	480	Ramp
8b	4	Vulcanized	18.3 / 20.5 / 21	480	Ramp
9a	4	Smooth	18.3 / 18.3 / 20	640	Ramp
9b	4	Vulcanized	18.3 / 20.5 / 21	640	Ramp
10aR	2	Smooth	14.6 / 14.6 / 16	160	Ramp
10bR	3	Vulcanized	14.6 / 16.8 / 18	160	Ramp
10cR	3	Threaded	M16 / M16 / 17	160	Ramp
10aD1	3	Smooth	14.6 / 14.6 / 16	160	DOL-1
10bD1	3	Vulcanized	14.6 / 16.8 / 18	160	DOL-1
10cD1	3	Threaded	M16 / M16 / 17	160	DOL-1
10aD2	3	Smooth	14.6 / 14.6 / 16	160	DOL-2
10bD2	3	Vulcanized	14.6 / 16.8 / 18	160	DOL-2
10cD2	3	Threaded	M16 / M16 / 17	160	DOL-2
10aD3	3	Smooth	14.6 / 14.6 / 16	160	DOL-3
10bD3	3	Vulcanized	14.6 / 16.8 / 18	160	DOL-3
10cD3	3	Threaded	M16 / M16 / 17	160	DOL-3

6.2 Test series 6a-9b, ramp loading of glued-in rods



The values indicated as "Mean τ_f ," in the below table is average failure load divided by an area calculated as $L_{\text{glue}}\pi d$, where d is taken as the steel diameter: i.e. 18.3 mm for series a and b 6-9 and 20.0 mm for series 6c (threaded rod M20).

The scatter in recorded displacement might partly be explained by the fact that the displacement was recorded only at one side of the rod, see above picture. For series 6c (glued threaded rod), it was apparent that many of the specimens were somewhat poorly glued. Glue had flown out from the hole when specimens were placed on the side before the glue was hard, leaving a non-glued area of a few cm^2 in size, see above picture. The ramp loading test results for series 10 are presented in section 6.3 together with the long duration of load test results. The rust seen on naked parts of the rods of the b I-IV specimens, i.e. parts not covered with rubber, may be related to the acid rinsing, see section 3.1.

Fracture surface pictures are shown for specimens 6b I and 6 b II in the below. These specimens were opened by saw cuts and a by use of a wedge after the testing. The actuator

displacement during testing was for specimen 6b I further increased by about 10 mm after peak load.

Ser.	No	Type	Failure loads, kN / failure mode ^{*)}				Mean failure	
			I	II	III	IV	load, kN	τ_f , MPa
6a	I-IV	Smooth 160	86.2 W	76.8 W+C	84.5 W	81.5 W+C	82.3	8.94
6b	I-IV	Vulcanized 160	42.4 RS	52.2 RS	55.5 RS	55.4 RS	51.4	5.59
6c	I-IV	Threaded 160	(68.5) S	56.3 B	67.0 B	(52.0) S	61.7	6.13
7a	I-IV	Smooth 320	192.9 W+C	126.4 W	176.6 W+C	169.5 W+C	166.4	9.04
7b	I-IV	Vulcanized 320	92.7 RS	96.9 RS	91.7 RS	90.9 RS	93.1	5.06
8a	I-IV	Smooth 480	162.2 W+C	145.5 W	203.6 W+C	139.8 W	162.8	5.90
8b	I-IV	Vulcanized 480	140.9 RS	133.2 RS	136.0 RS	131.1 RS	135.3	4.90
9a	I-IV	Smooth 640	179.8 W+C	194.2 W+C	161.3 W	209.9 W	186.3	5.06
9b	I-IV	Vulcanized 640	87.3 RS	138.1 RS	122.3 RS	85.7 RS	108.4	2.95

^{*)} W = Wood shear fracture close to the bond surface or in the wood-glue interface, often with pullout of a wood-plug around the bar, the plug presumably being at the least some cm in length.

C = Cleavage of the wood. Major, more or less radial cracks from the rod to the edge of the specimen.

RS = Rubber-to-steel interface shear fracture. During fracture a sound like tearing was heard. The course of fracture was not visible from the outside of the specimen. Pull-out of an entire rod showed on part of the area thin remains of fractured rubber on the rod. The appearance of the rubber-to-steel interface with spots of some brown/red coloring and remains (see pictures of specimens that were cut open after testing) suggests some corrosion of the steel surface.

S = Support end failure of the specimen. Failure load not considered in evaluation of mean failure load.

B = Bond shear fracture. Fracture between the threaded rod and the wood.

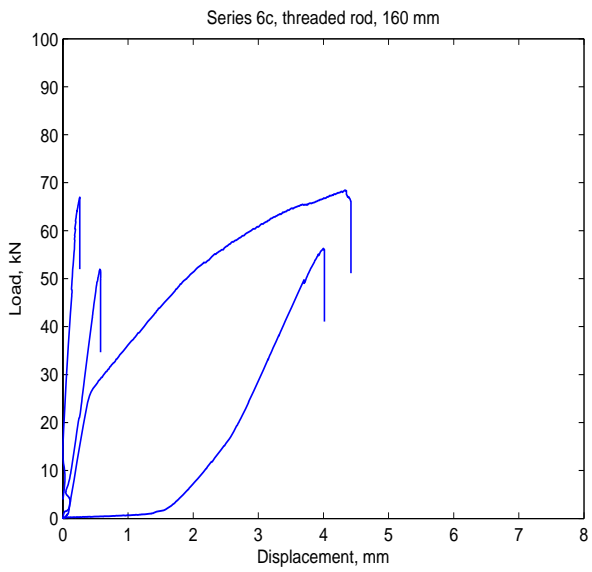
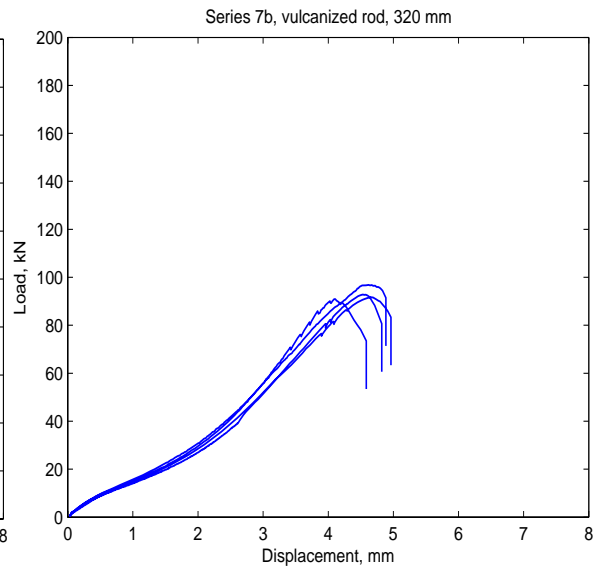
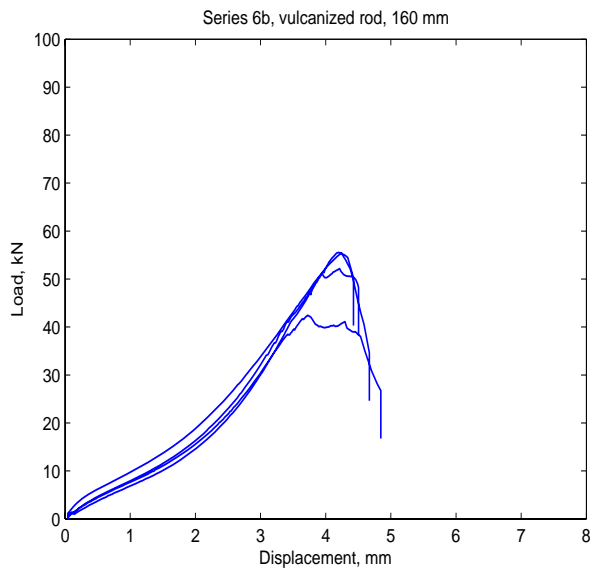
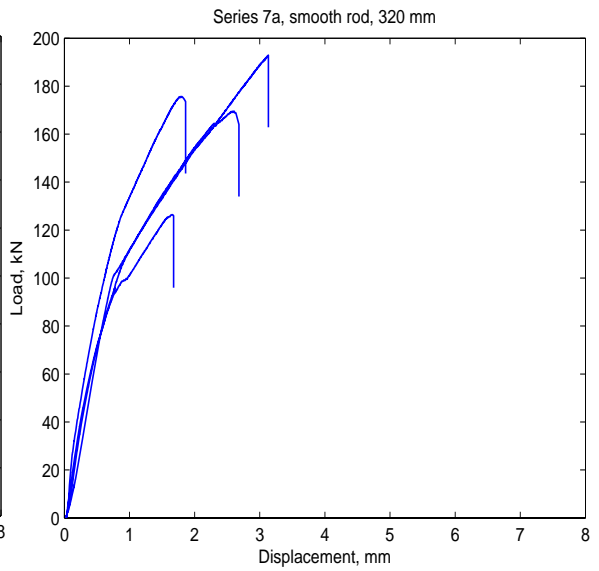
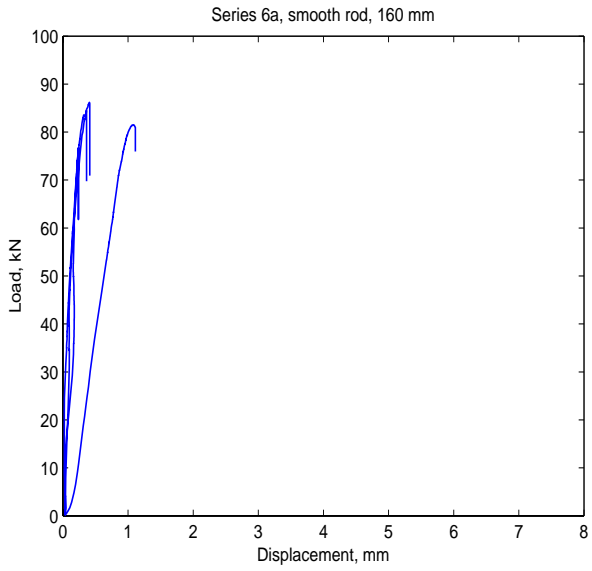

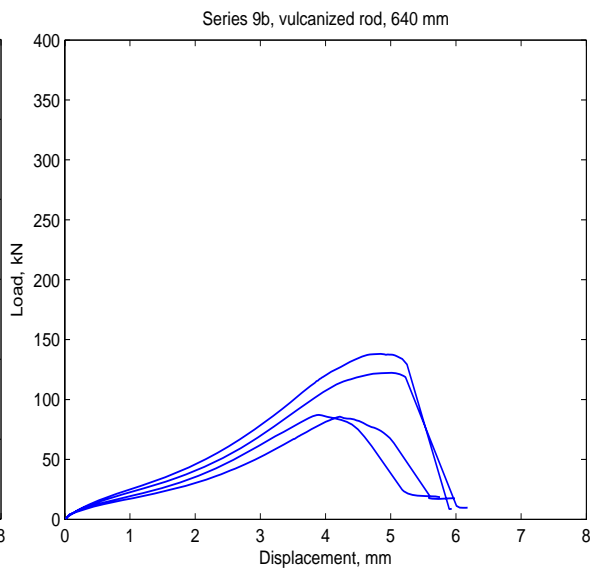
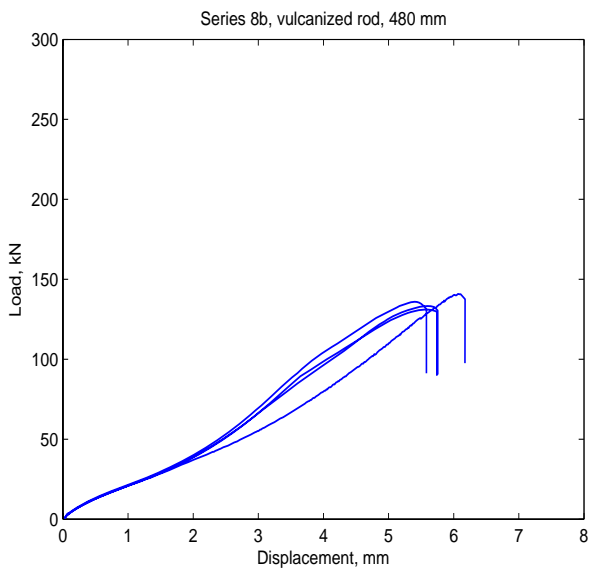
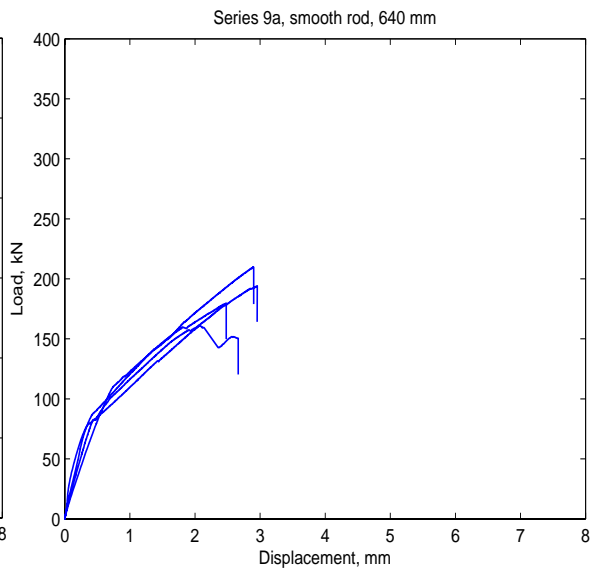
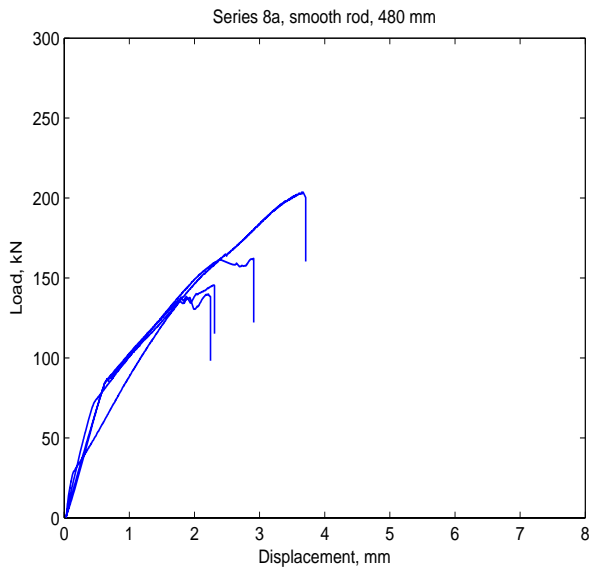

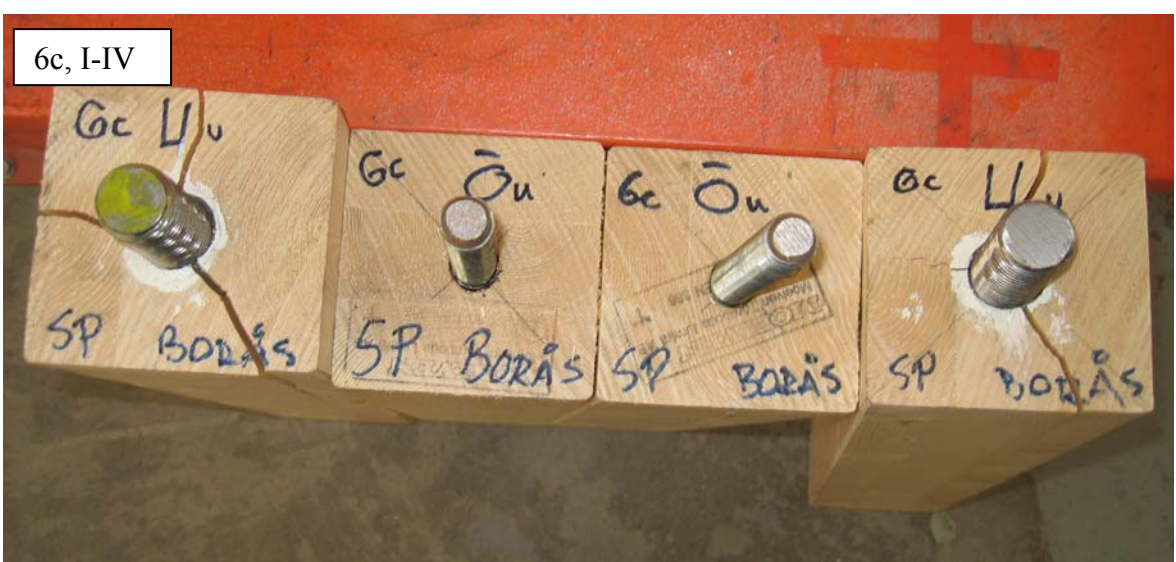

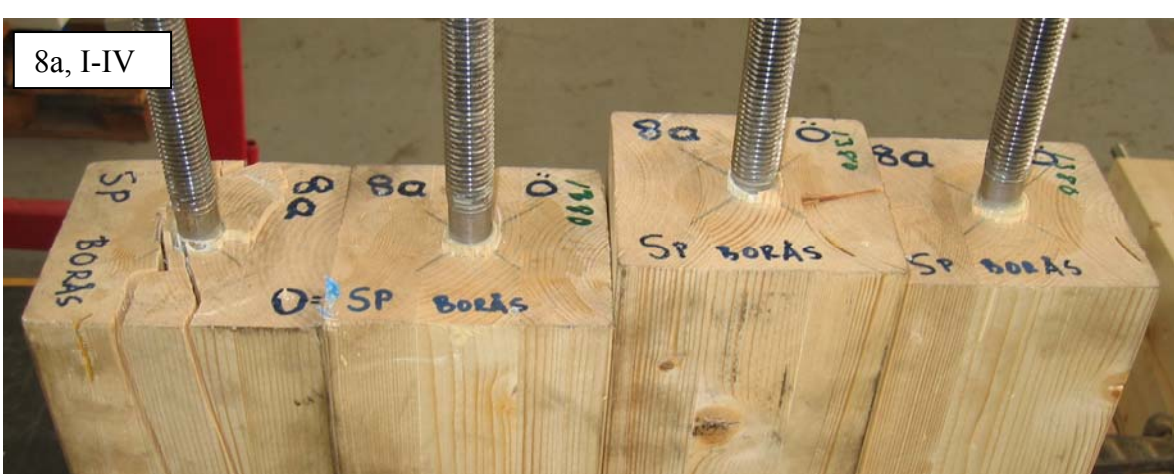

9a, I-IV



9b, I-IV



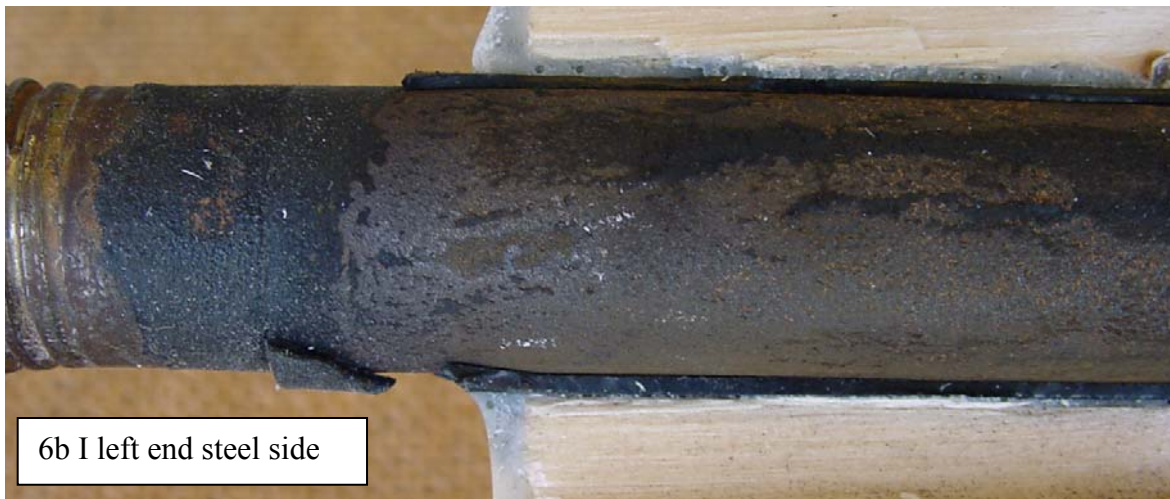

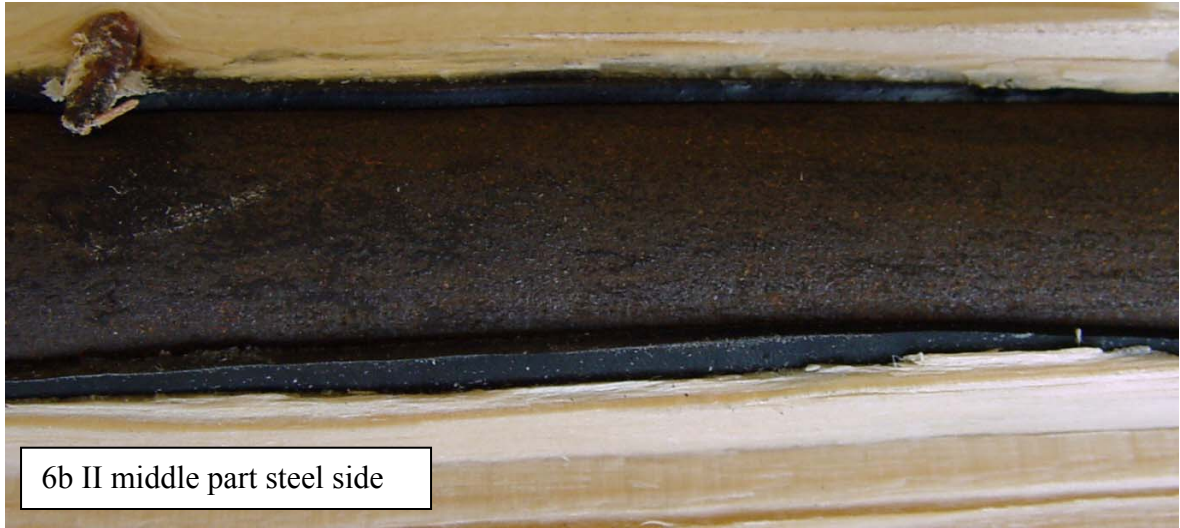

6b II middle part steel side

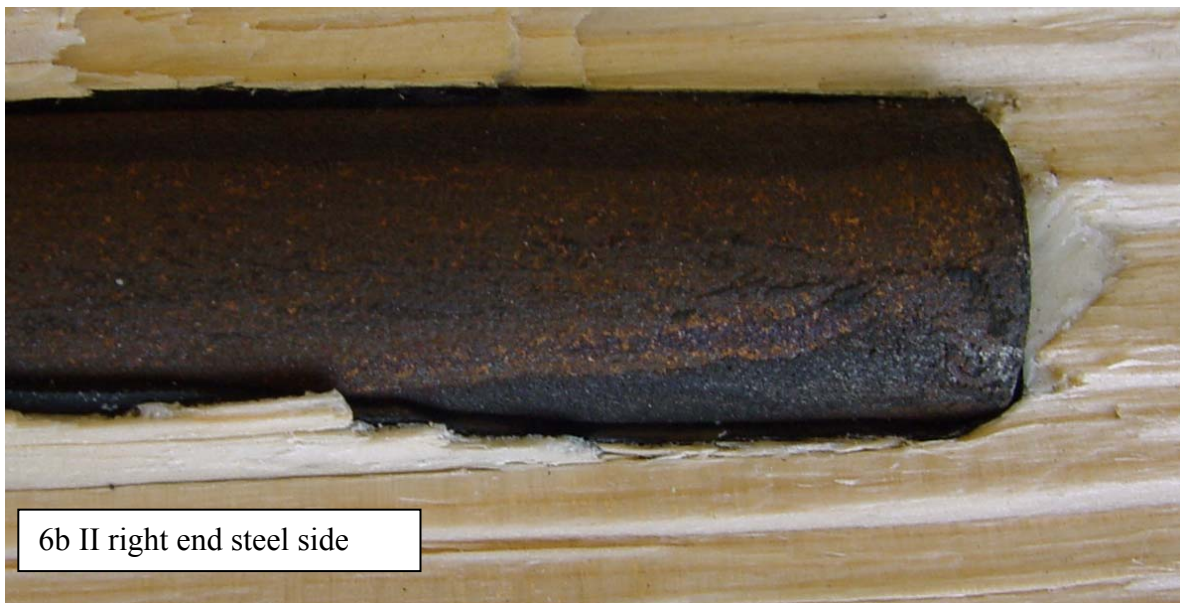

6b II right end steel side



6b II right end rubber side

6.3 Test series 10aR-10cD3, DOL testing of glued-in rods



Above are photos showing the ramp load reference test before the constant load DOL tests. The actuator speed was constant during each ramp loading test, but different for the different tests, giving times to failure about in the order of 5-10 minutes. The following results were obtained:

Series	Spec.	Type of specimen	Failure load, kN time, min / displacement, mm			Mean failure	
			I	II	III	load, kN	stress τ_f , MPa
10aR	I-II	Smooth	67.6 6.1 / 0.9	61.9 7.7 / 0.7	- - / -	64.8	9.01
10bR	I-III	Vulcanized	32.8 13.2 / 4.2	37.0 5.7 / 4.2	36.1 5.3 / 4.2	35.3	4.91
10cR	I-III	Threaded	75.2 7.8 / 1.0	58.5 5.4 / 0.6	(50.4) (4.5 / 0.8)	66.9	8.31

() flaw $\sim 2 \times 25 \text{ mm}^2$ without glue

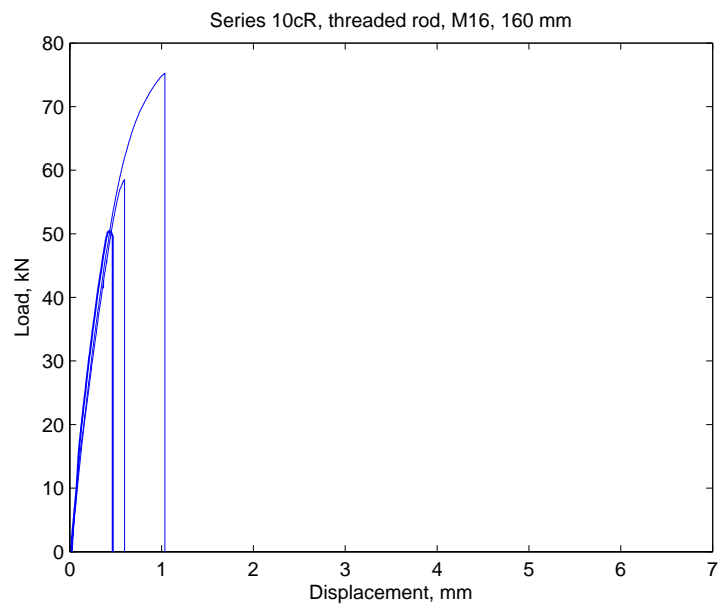
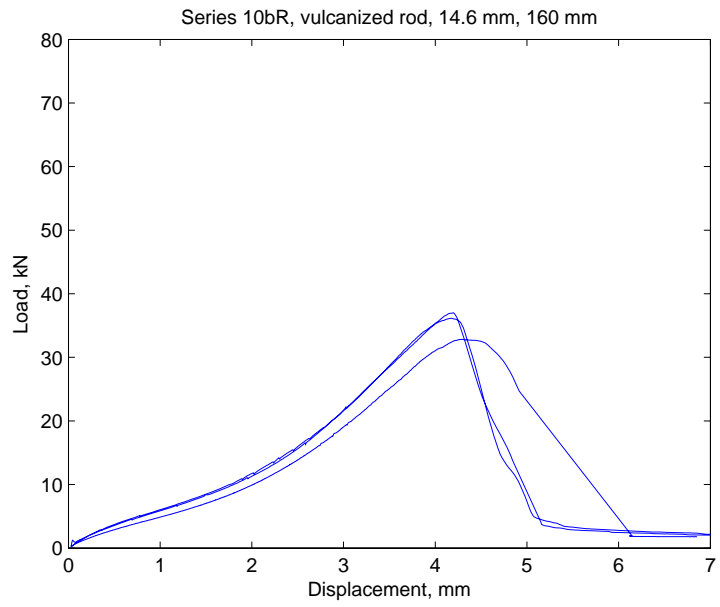
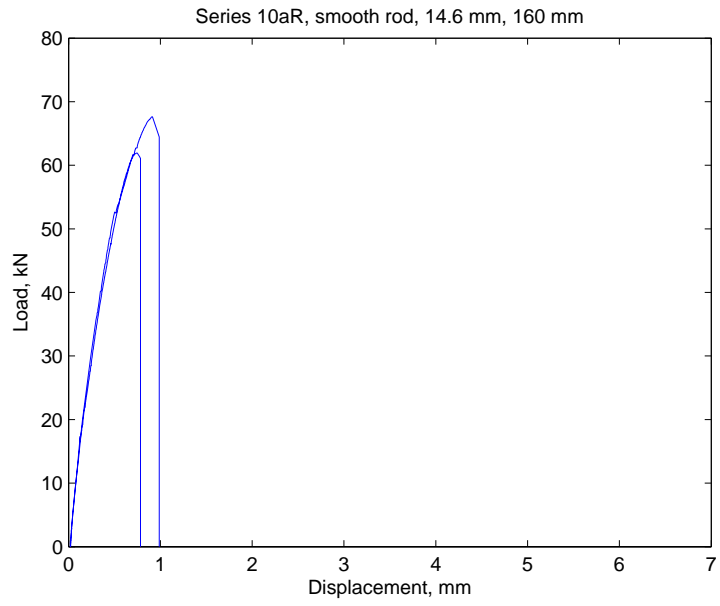

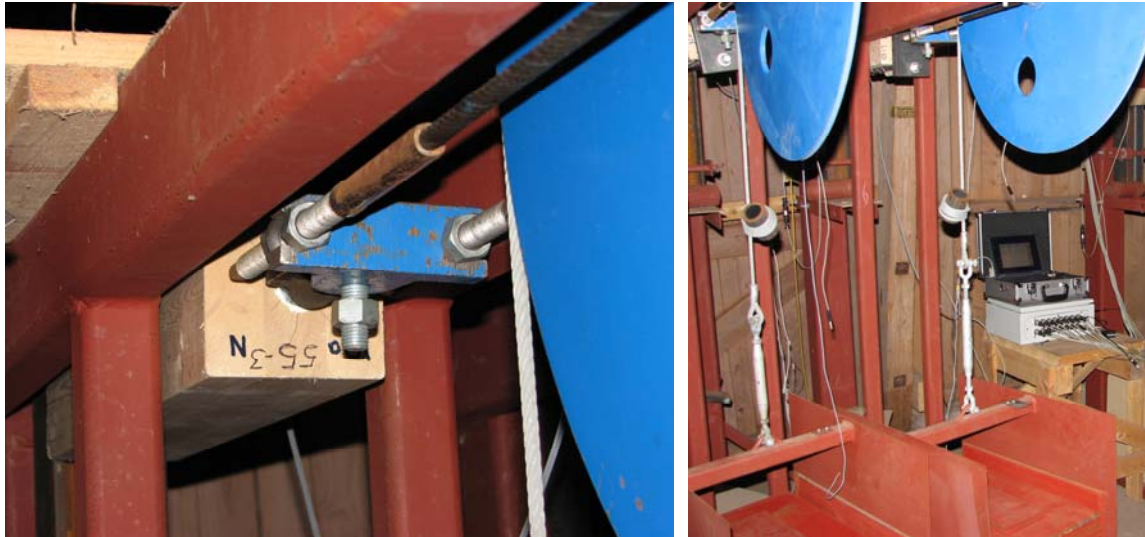

The duration of load tests were made in an open shelter in southern Sweden during late spring-summer 2006. The test result, see below, show throughout short times to failure and in particular very short times to failure for the conventionally glued specimens without any rubber foil. Any obvious explanation to the apparently poor duration of load performance recorded in these tests has not been found. Other tests on conventionally glued glued-in rods tested at the same testing site have indicated a better duration of load performance.

Series	Spec.	Type of specimen	Time to failure, h:m				Load,		
			I	II	III	Median	kN	MPa	%
10aD1	I-III	Smooth	<0:01	5:35	<0:01	<0:01	51.8	7.21	80
10bD1	I-III	Vulcanized	0:44	1:10	4:12	1:10	28.2	3.92	80
10cD1	I-III	Threaded	10:20	<0:01	<0:01	<0:01	53.5	6.65	80
10aD2	I-III	Smooth	0:18	0:16	0:07	0:16	45.4	6.32	70
10bD2	I-III	Vulcanized	0:03	3:47	33:50	3:47	24.7	3.44	70
10cD2	I-III	Threaded	0:34	0:01	0:01	0:01	46.8	5.82	70
10aD3	I-III	Smooth	3:14	4:48	2:31	3:14	35.6	4.95	55
10bD3	I-III	Vulcanized	10:13	98:11	124:14	98:11	19.4	2.70	55
10cD3	I-III	Threaded	441:06	28:58	103:56	103:56	36.8	4.58	55

7. Steel plate-to-glulam lap joints

7.1 Test series 11a, nailed 160 mm outer double lap joint

The shaping of the specimens is given in the below figure. Three nominally equal specimens were tested. The actuator speed was 3 mm/min. The displacement recorded was the movement of the actuator.

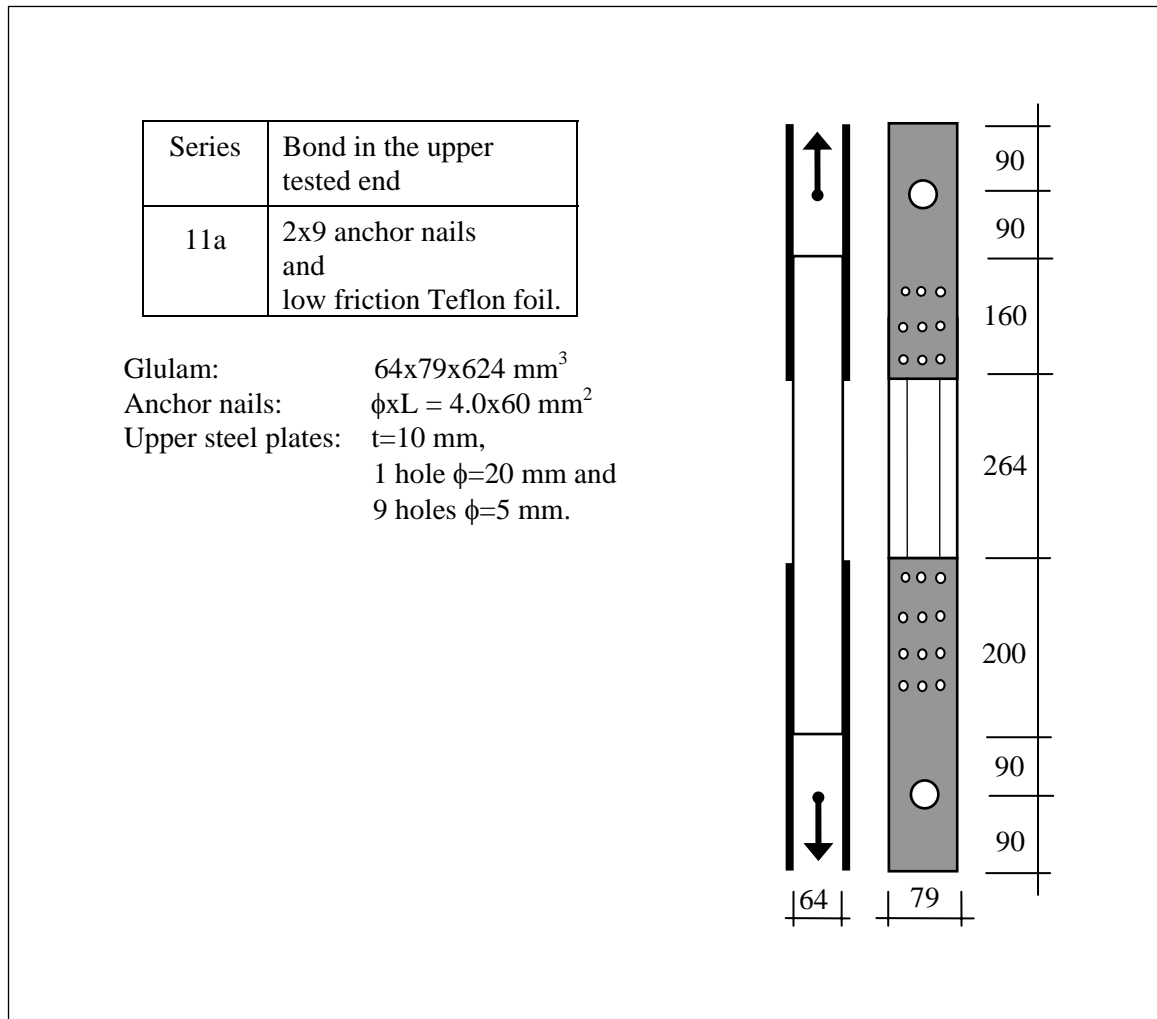

In the below table is δ_f the piston movement at failure, τ_f is the mean shear stress acting across the bond area and σ_f is the mean normal stress in the wooden member.

Test no.	P_f kN	δ_f mm	τ_f MPa	σ_f MPa	Cause of failure
I	37.3	13.5	1.48	7.4	Local failure at nails
II	34.1	8.9	1.35	6.7	Local failure at nails
III	25.2	11.9	1.00	5.0	Local failure at nails

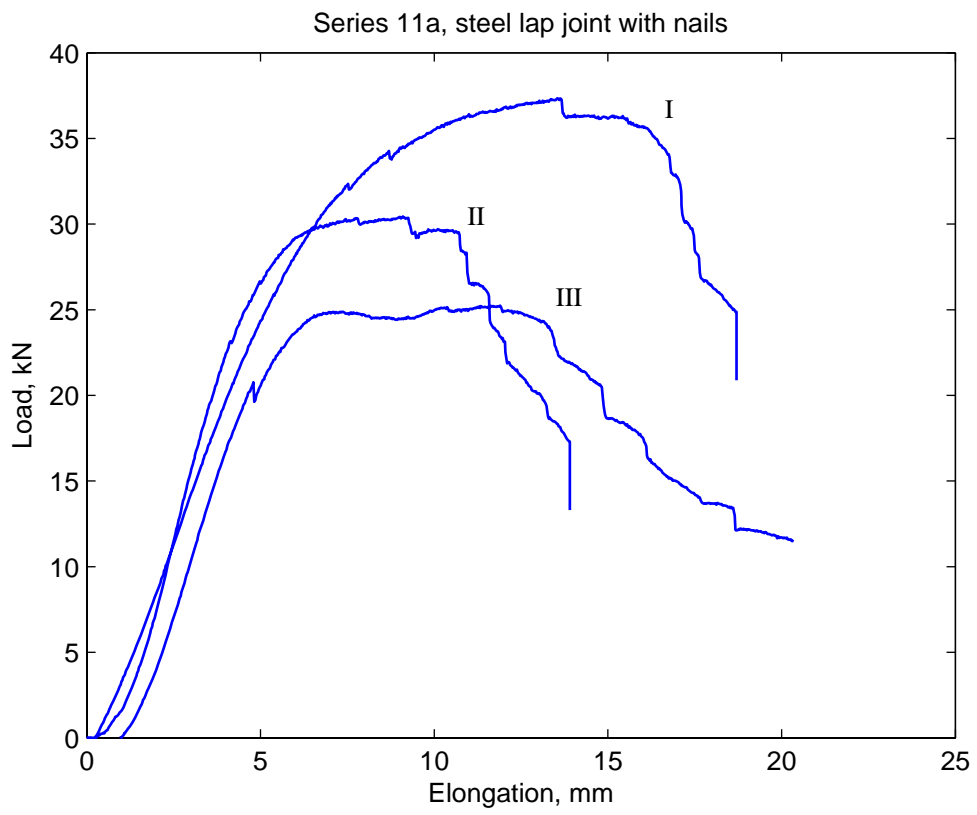

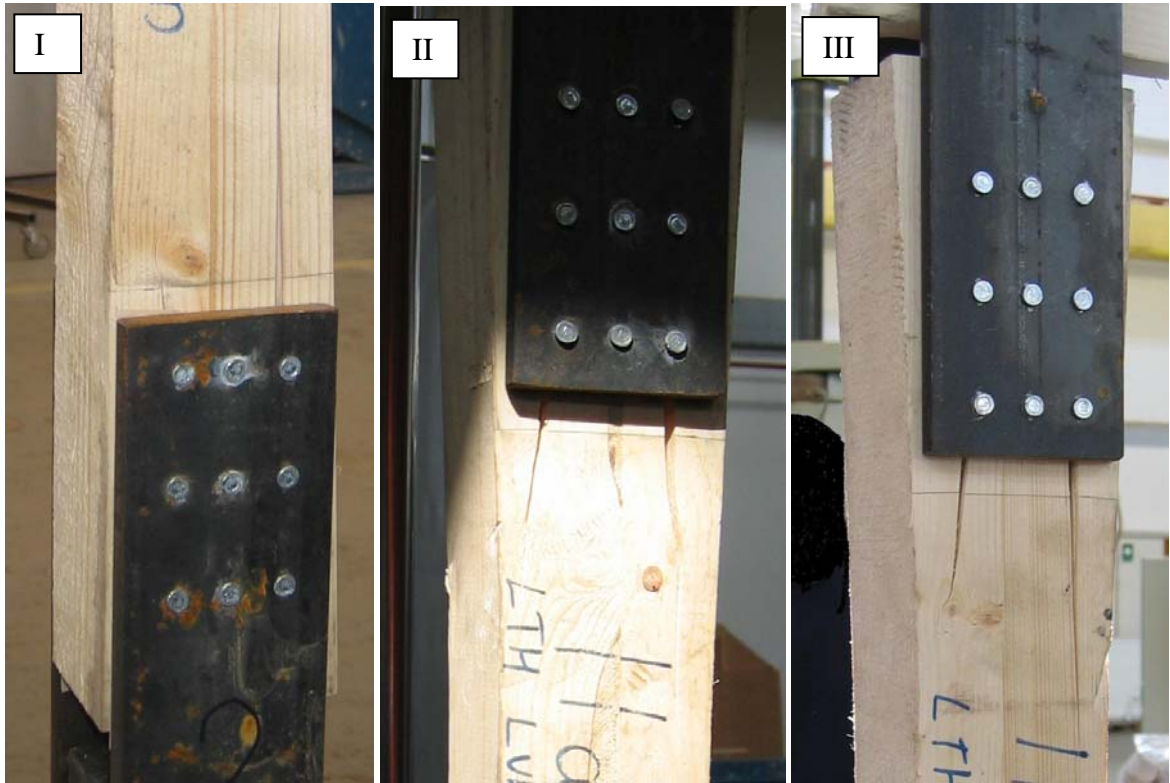

7.2 Test series 11b, glued 160 mm outer double lap joint

The shaping of the specimens is given in the below figure. Only two nominally equal specimens were tested. The actuator speed was 3 mm/min. The displacement recorded was the movement of the actuator.

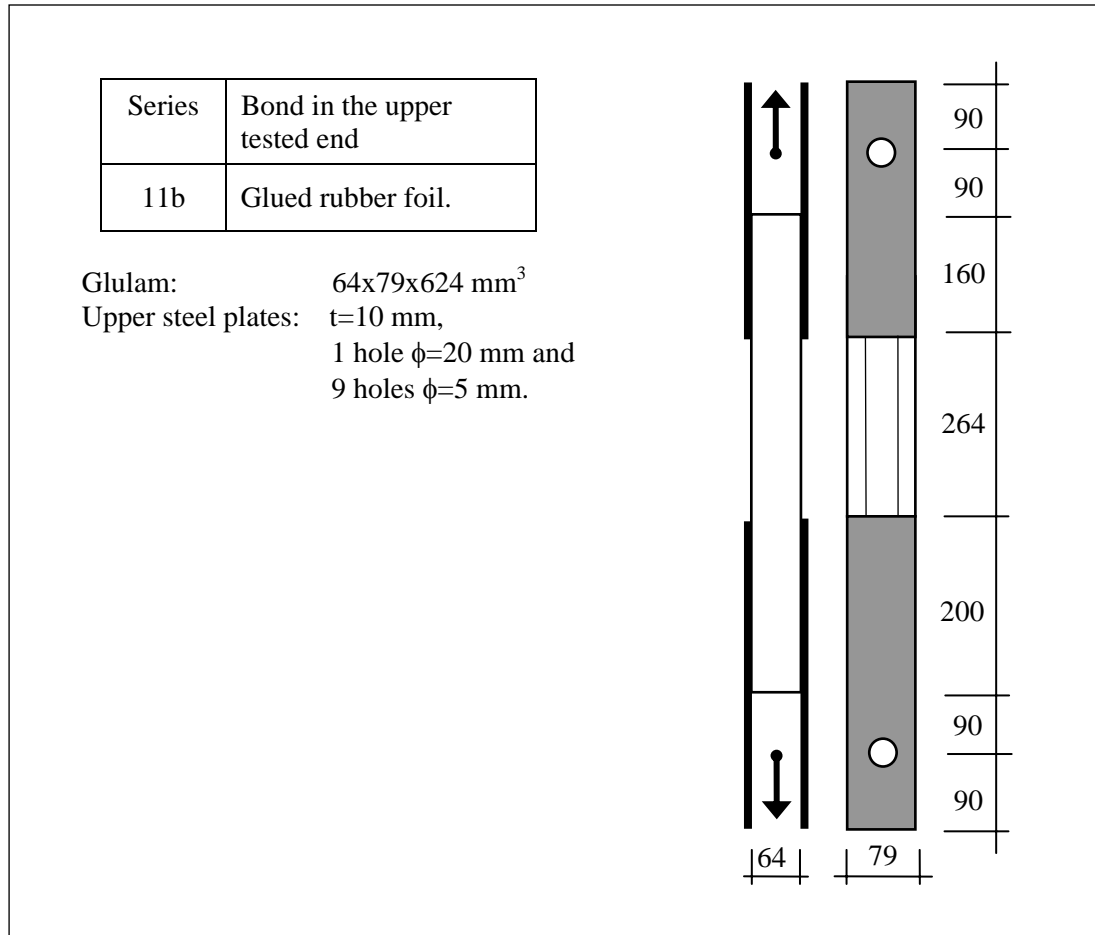

In the below table is δ_f the piston movement at failure, τ_f is the mean shear stress acting across the bond area and σ_f is the mean normal stress in the wooden member.

Test no.	P_f kN	δ_f mm	τ_f MPa	σ_f MPa	Cause of failure
I	73.7	9.5	2.92	14.6	Shear fracture in wood (~90%) and in rubber surface at the wood side (~10%).
II	108.6	10.0	4.30	21.5	Shear fracture in wood (~80%) and in rubber surface at the wood side (~20%).

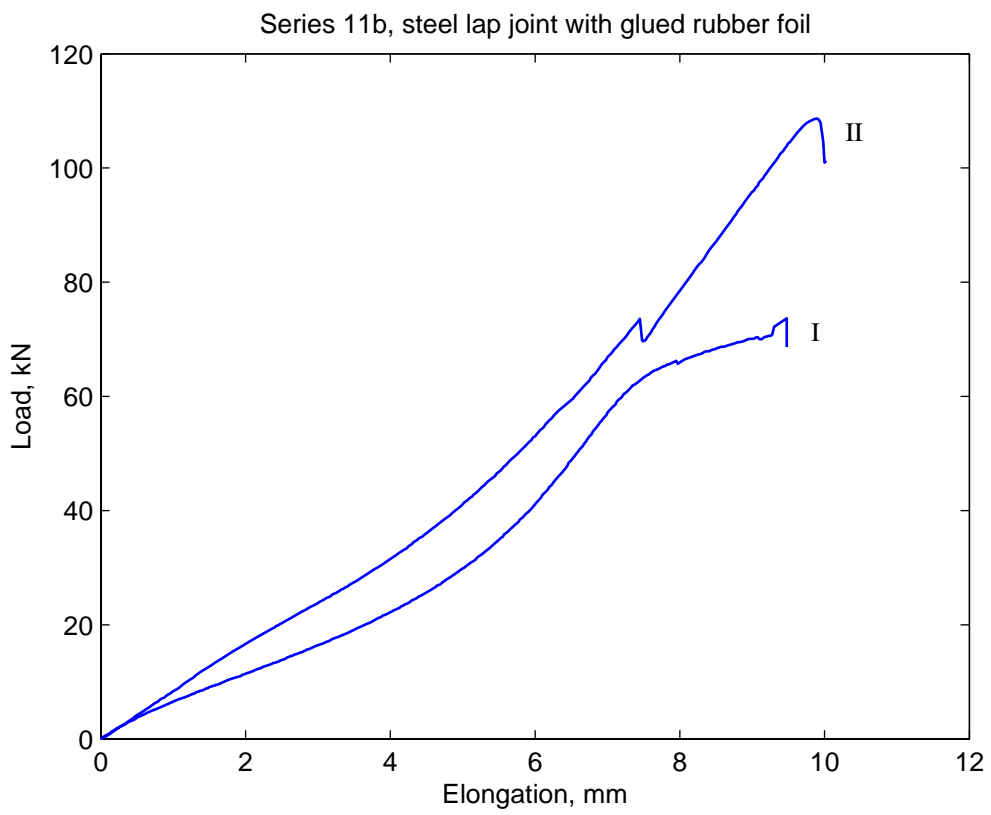



7.3 Test series 11c, nailed and glued 160 mm outer double lap joint

The shaping of the specimens is given in the below figure. Three nominally equal specimens were tested. The actuator speed was 3 mm/min. The displacement recorded was the movement of the actuator.

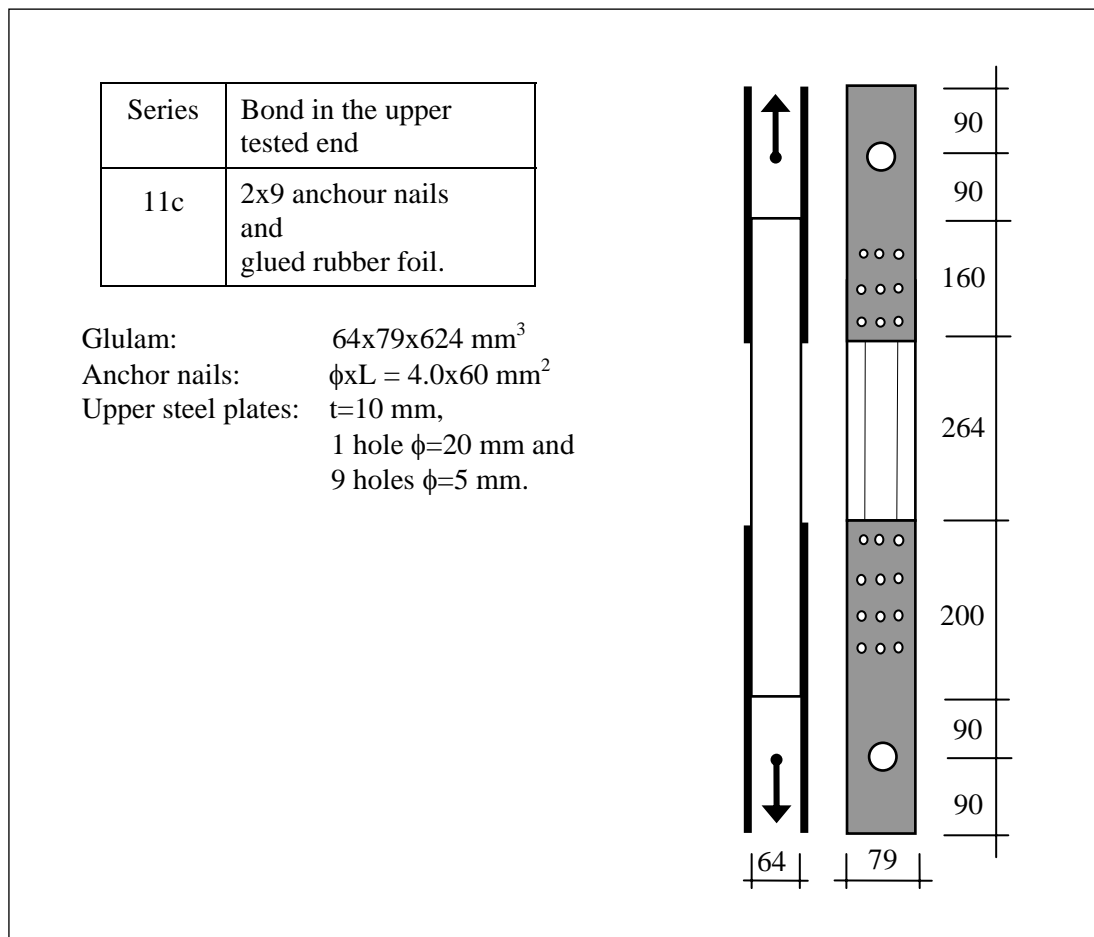

In the below table is δ_f the piston movement at failure, τ_f is the mean shear stress acting across the bond area and σ_f is the mean normal stress in the wooden member.

Test no.	P_f kN	δ_f mm	τ_f MPa	σ_f MPa	Cause of failure
I	133.8	10.4	5.29	26.5	Shear fracture in wood.
II	151.0	10.7	5.97	29.9	Shear fracture in wood (~70%) and in rubber surface at wood side (~30%).
III	126.4	9.7	5.00	25.0	Shear fracture in wood.

In the below are two diagrams shown, one giving a comparison between the results of series 11c with the results of 11a.

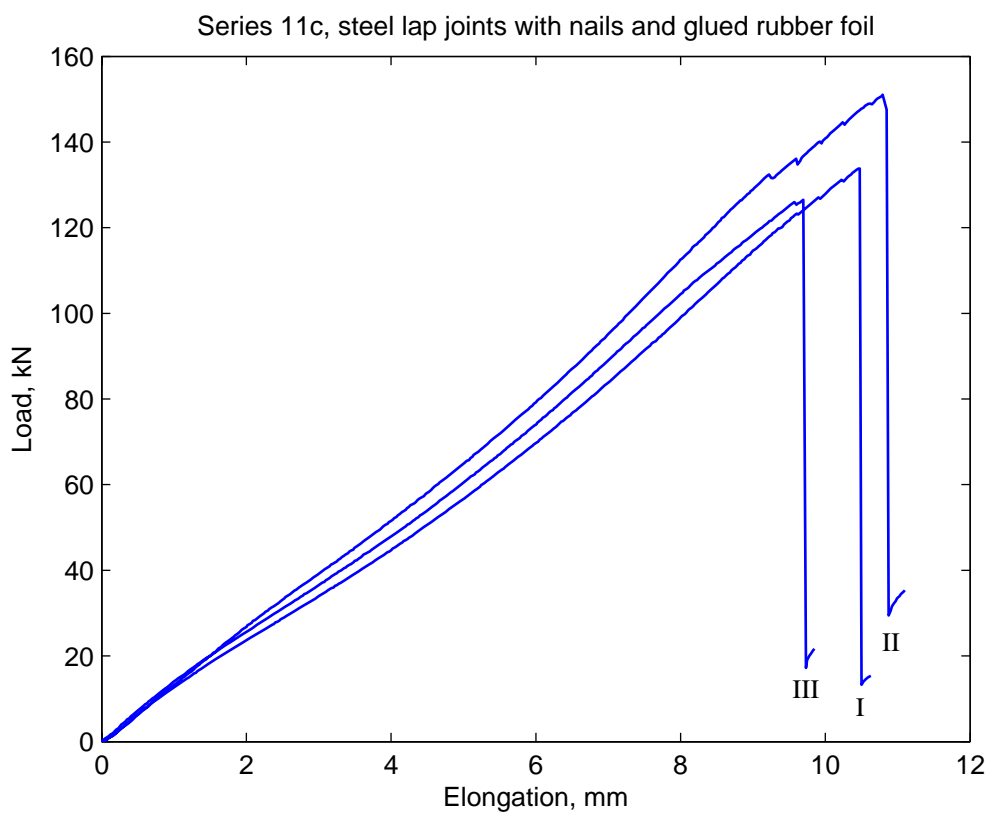

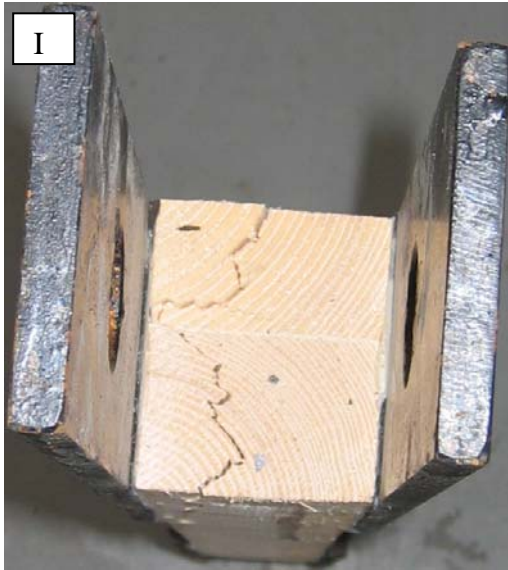

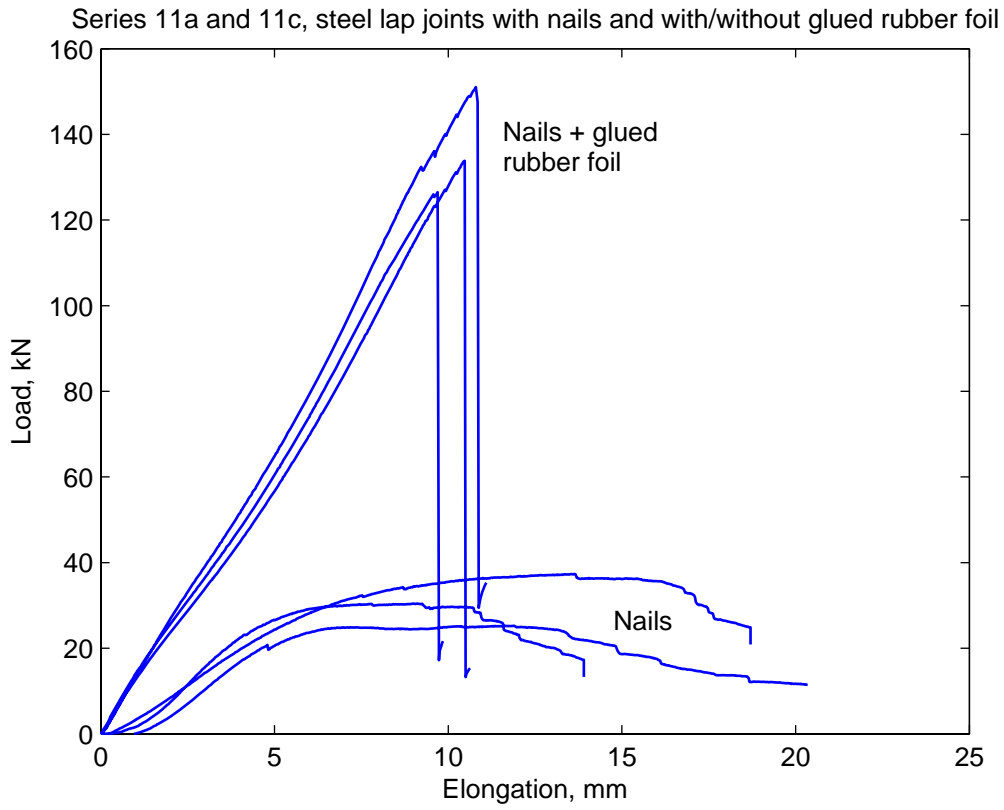

7.4 Test series 12, glued 160 mm inner double lap joint

The shaping of the specimens is given in the below figure. Three nominally equal specimens were tested. The actuator speed was 3 mm/min. The displacement recorded was the movement of the actuator. The test results are indicated by the below table, diagram and pictures.

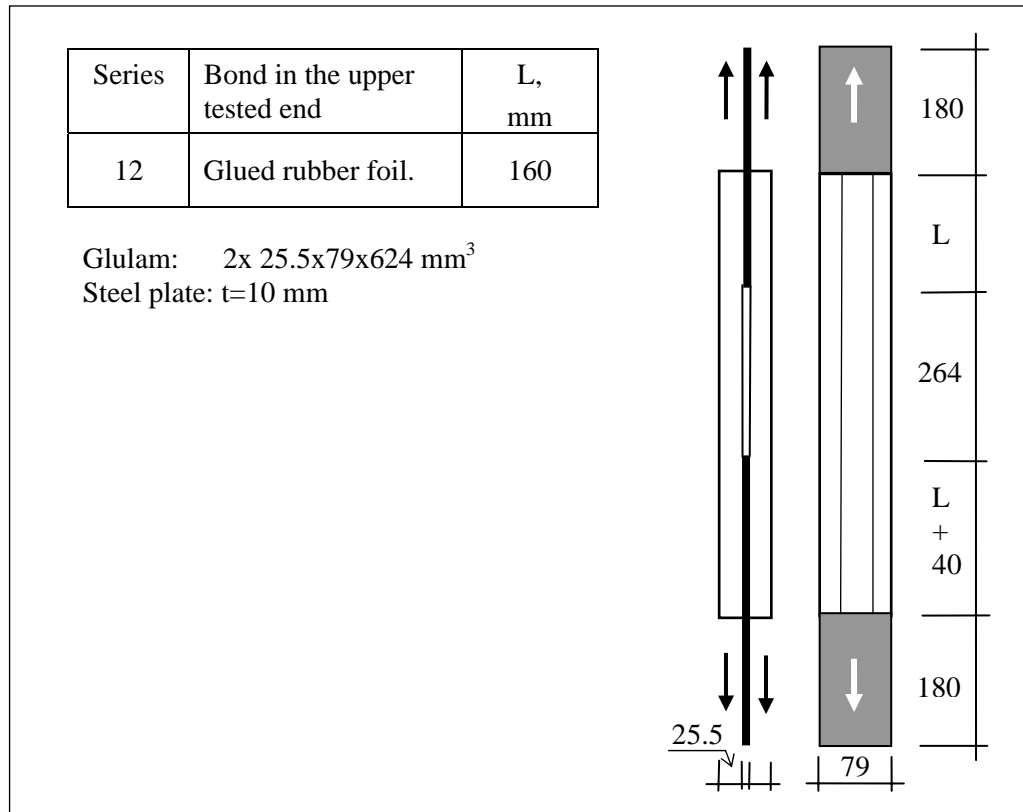

No	P _f kN	δ _f mm	τ _f MPa	σ _f MPa	Cause of failure, left side	Cause of failure, right side
I	110.9	7.7	4.39	27.5	~40% tensile rupture in wood, ~60% shear/perp. tension fracture in wood along bond area	~50% tensile rupture in wood, ~50% shear/perp. tension fracture in wood along bond area
II	125.3	9.0	4.96	31.1	100% tensile rupture in wood,	100% shear/perp. tension fracture in wood along bond area
III	147.9	10.2	5.85	36.7	~60% tensile rupture in wood, ~40% shear/perp. tension fracture in rubber-wood interface	~20% tensile rupture in wood, ~80% shear/perp. tension fracture in rubber-wood interface



Series 12, inner steel plate rubber foil lap joints, 160 mm

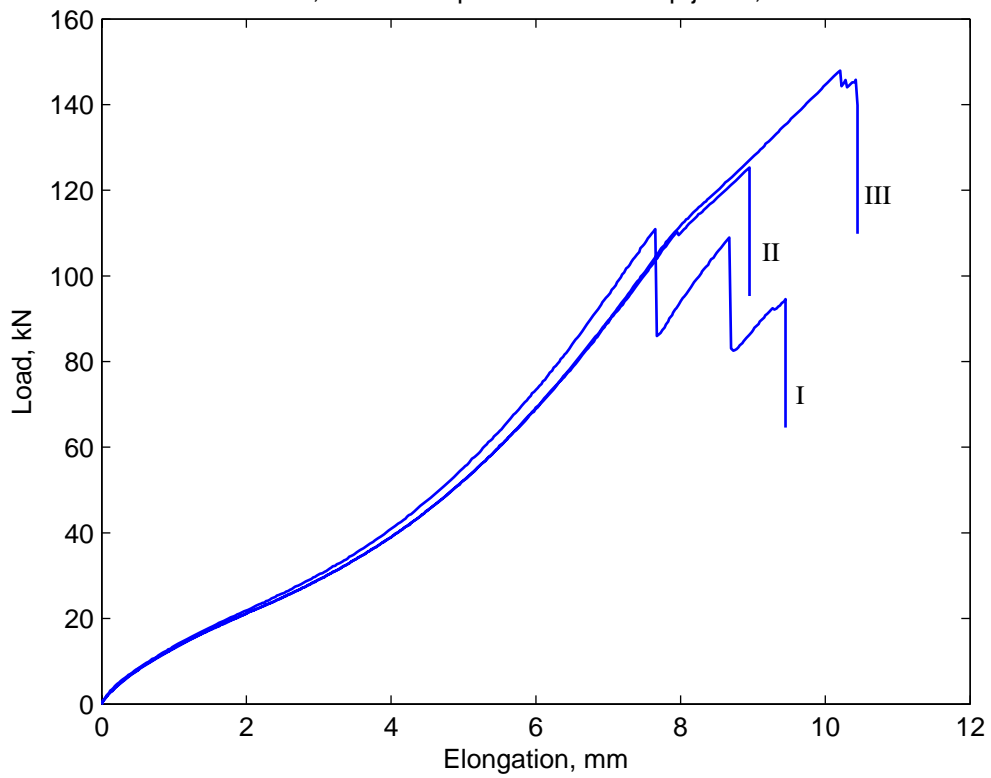



7.5 Test series 13, glued 320 mm inner double lap joint

The shaping of the specimens is given in the below figure. Three nominally equal specimens were tested. The actuator speed was 3 mm/min. The displacement recorded was the movement of the actuator. The test results are indicated by the below table, diagrams and pictures. One diagram shows a comparison with test series 12.

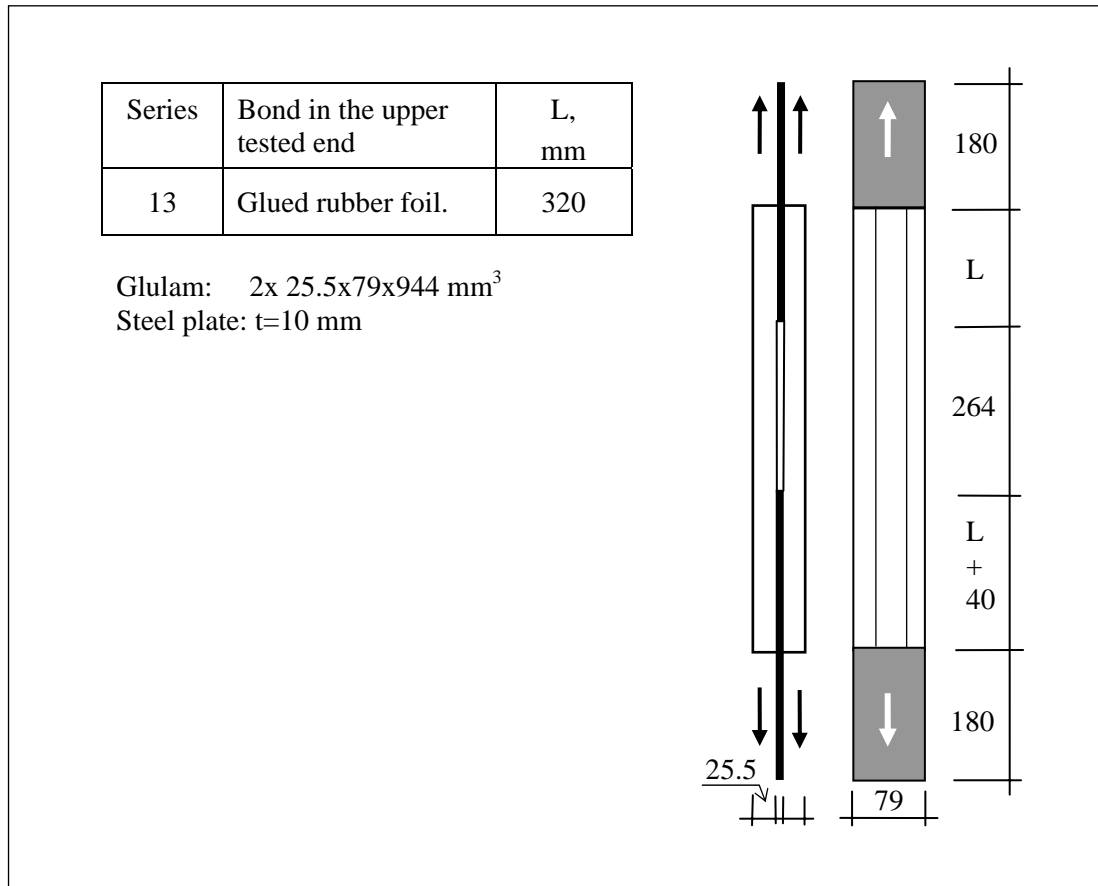

Test no.	P _f kN	δ _f mm	τ _f MPa	σ _f MPa	Cause of failure, left side	Cause of failure, right side
I	154.0	9.9	3.05	38.2	Tensile rupture.	Tensile rupture.
II	134.0	8.2	2.65	33.3	Shear/perp tension fracture in wood along bond area.	Tensile rupture.
III	225.4	13.2	4.46	55.9	Shear/perp.tension fracture in wood along bond area.	Tensile rupture.



Series 13, inner steel plate rubber foil lap joints, 320 mm

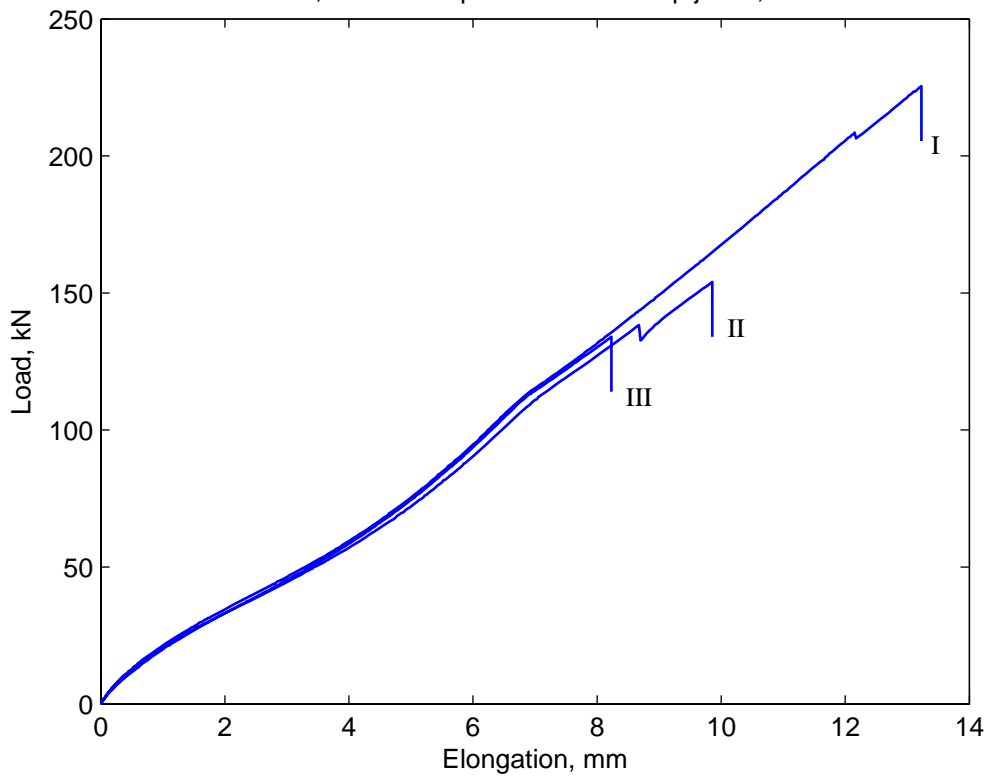

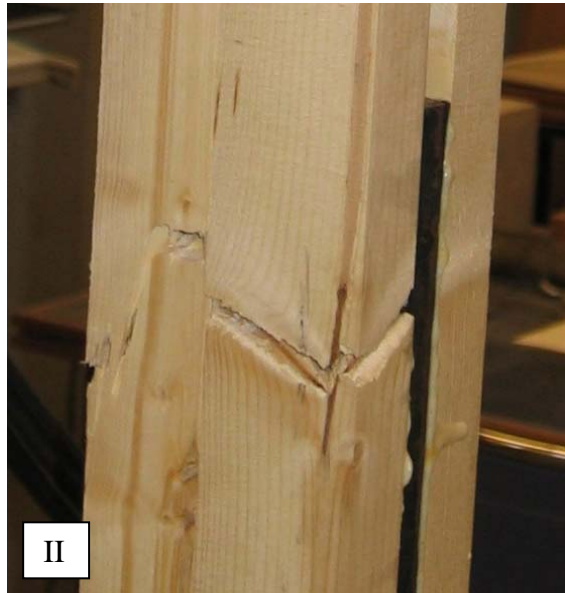

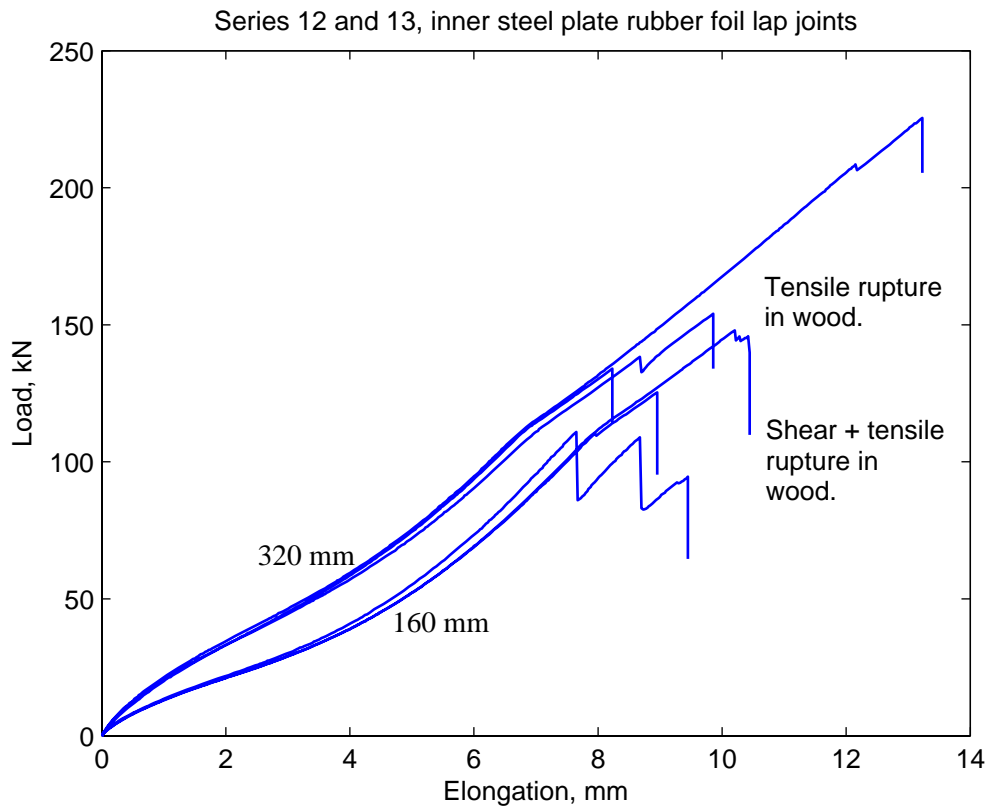

7.6 Test series 14a, glued plates loaded parallel with grain

The shaping of the specimens is given in the below figure. Three nominally equal specimens were tested. The actuator speed was 3 mm/min. The displacement recorded was the movement of the actuator. The test results are indicated by the below table, diagrams and pictures. δ is the piston movement, τ is the mean shear stress acting across the bond areas and σ is the mean normal stress in the wooden member, i.e. the load divided by the total cross section area $64 \times 315 \text{ mm}^2$.

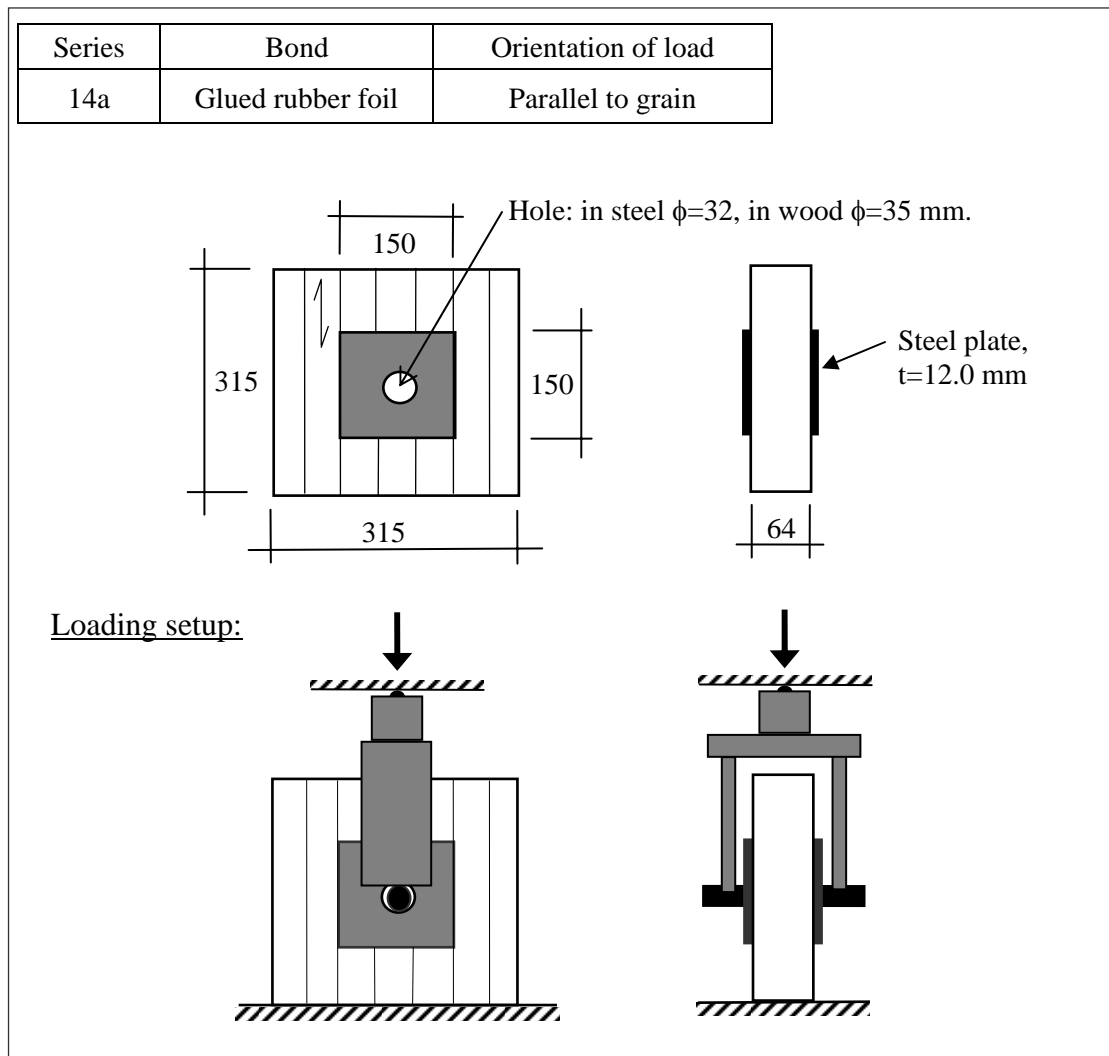

Test no.	P_f kN	δ_f mm	τ_f MPa	σ_f MPa	Cause of failure,
I	275.0	8.6	6.38	13.6	~100% shear fracture in wood
II	280.1	9.2	6.50	13.9	~ 70% shear fracture in wood ~ 20% fracture in rubber surface at wood side ~ 10% fracture in rubber layer
III	277.7	8.7	6.45	13.8	~ 70% shear fracture in wood ~ 30% fracture in rubber surface at wood side

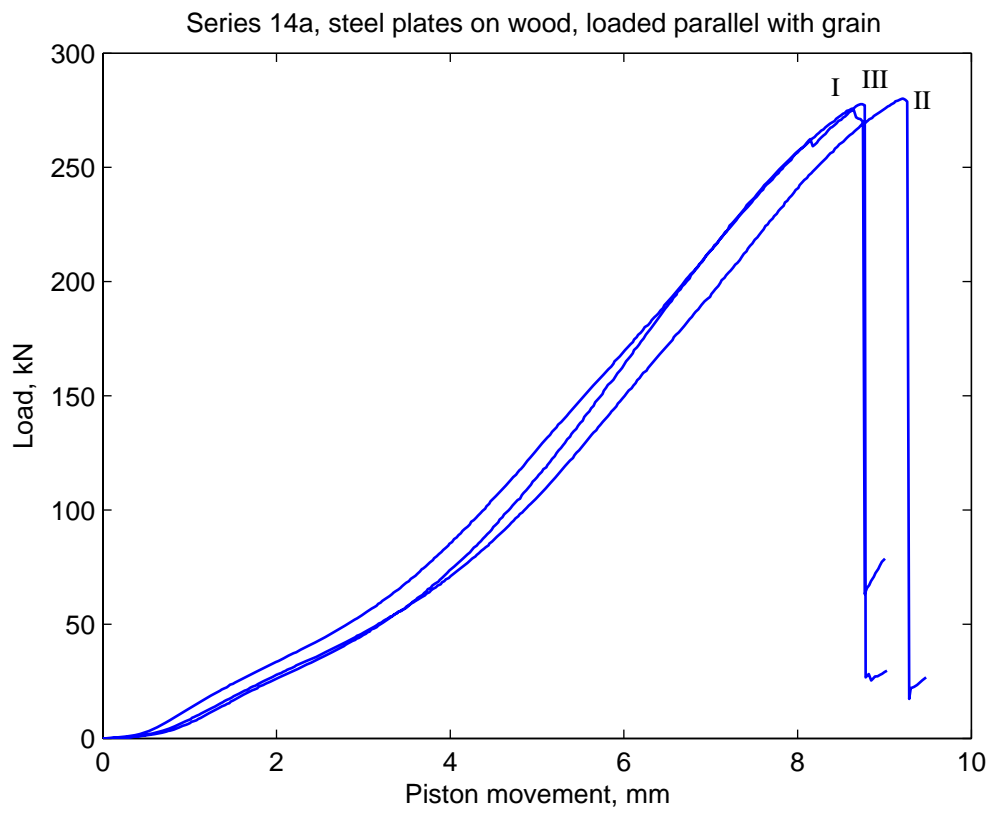

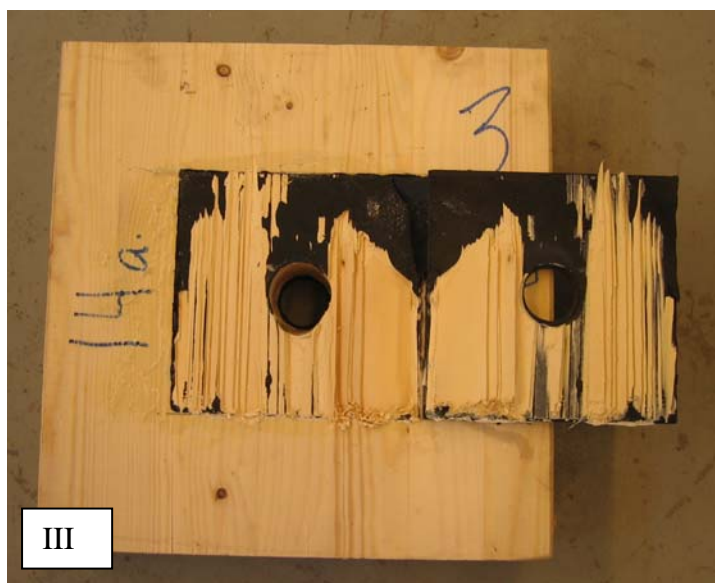

7.7 Test series 14b, glued plates loaded perpendicular to grain

The shaping of the specimens is given in the below figure. Three nominally equal specimens were tested. The actuator speed was 3 mm/min. The displacement recorded was the movement of the actuator. The test results are indicated by the below table, diagrams and pictures. δ is the piston movement, τ is the mean shear stress acting across the bond areas and σ is the mean normal stress in the wooden member, i.e. the load divided by the total cross section area $64 \times 315 \text{ mm}^2$. One diagram shows a comparison with test series 14a.

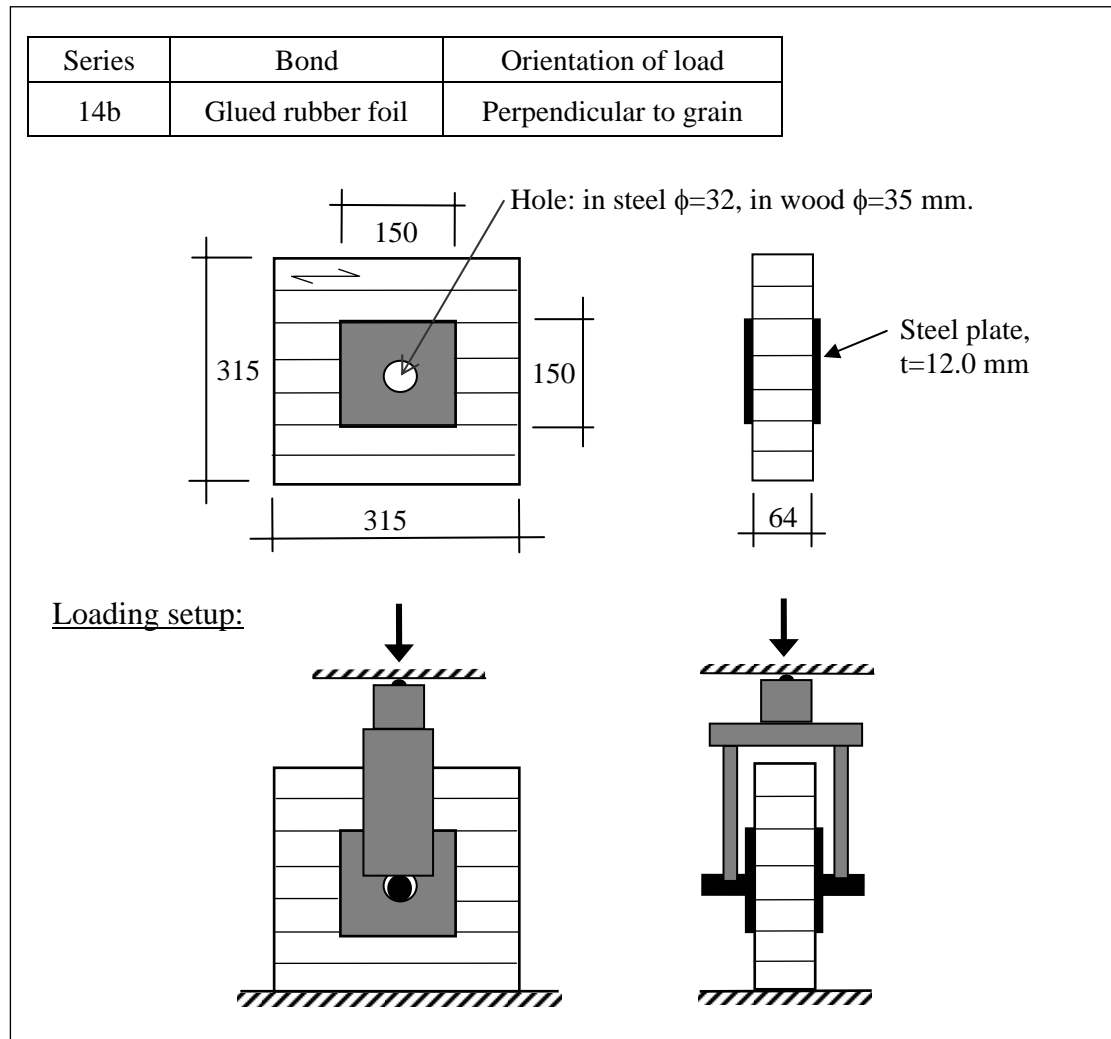

Test no.	P_f kN	δ_f mm	τ_f MPa	σ_f MPa	Cause of failure,
I	93.4	12.5	>2.17	4.6	Perp. to grain compressive failure of wood.
II	92.3	20.2	>2.14	4.6	Perp. to grain compressive failure of wood.
III	97.5	11.7	>2.26	4.8	Perp. to grain compressive failure of wood.

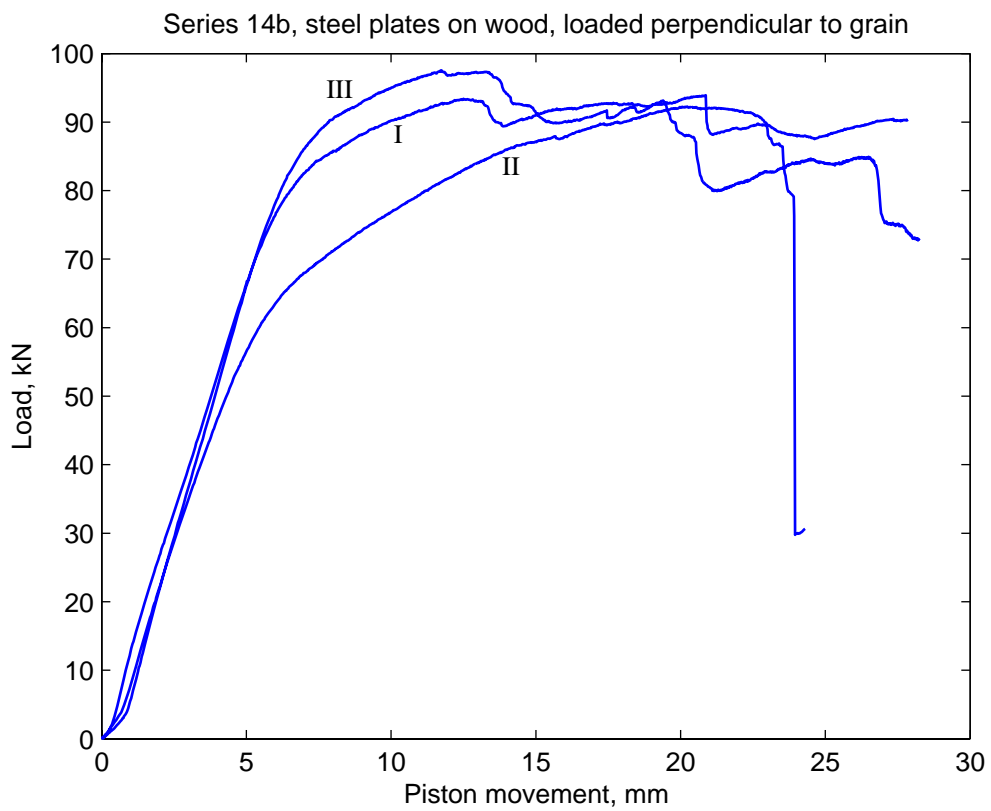

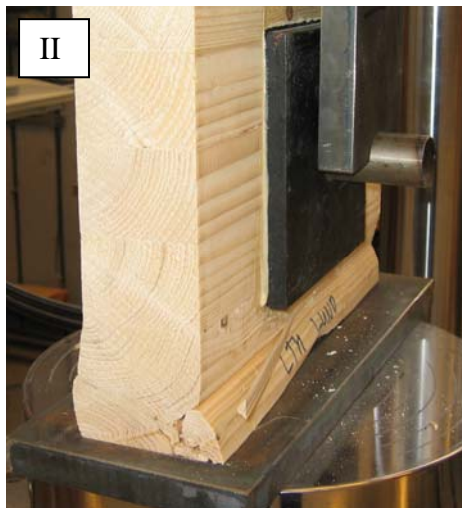

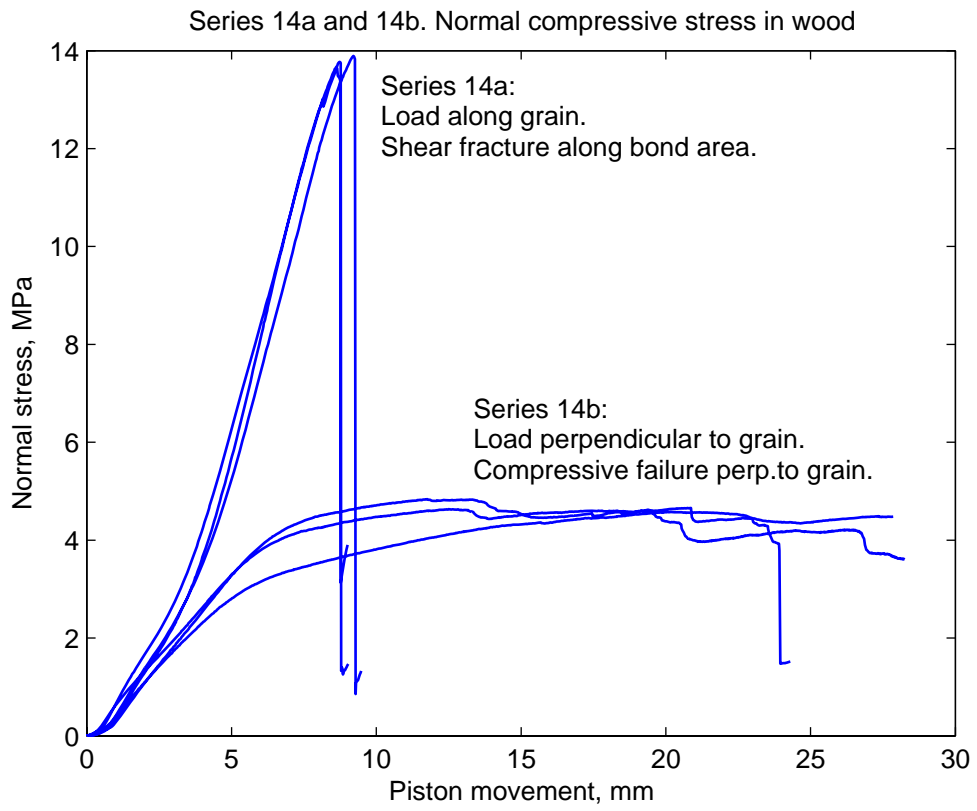

8. Concluding remarks

8.1 Lap joints

Good results were throughout recorded with respect to the performance of the rubber foil adhesive bonds during the tests of

- glulam-to-glulam joints,
- LVL-to-glulam joints and
- steel plate-to-glulam joints.

In none of the 15 test series was bond fracture dominating. In those cases where bond fracture was observed on part of a fracture area, the fracture almost throughout seemed to develop in the surface of the rubber foil, leaving the major part of the rubber at one side and only a very thin black coating on the other side.

Instead of bond fracture, various kind of failure in the wooden parts developed at high load. The wood failure modes observed included tensile fracture parallel with grain, tensile fracture perpendicular to grain, shear fracture along grain, rolling shear fracture and compressive failure perpendicular to grain. The possibility to transfer large forces and bending moments through a joint makes it very important in strength design of glued rubber foil joints to consider not only the stresses acting at the bond area, but also the stresses in parts of the wood outside the actual bond area.

Since no well defined bond fracture was observed, it is difficult to estimate strength parameters valid for bond fracture. The results of testing series 14a suggests that shear stress giving bond fracture may be about 6.0 MPa or possibly somewhat higher for the qualities of glue and rubber used in the present tests. In evaluation of test series 14a, note that some small fraction of the load could have been carried by direct contact bolt-to-wood in spite of different size of the hole in the wood and in the steel.

8.2 Glued-in steel rods

While the above discussed three testing groups gave good results, some poor results were recorded in some of the test series relating to glued-in steel rods. In all the tests of rubber foil glued-in rods, failure apparently developed as shear rupture in the rubber-to-steel interface. The highest shear strength, 5.6 MPa, was obtained in series 6b and the lowest, 3.0 MPa, in series 9b. This low shear strength recorded for the longest rods suggests that some kind of mistake might have been made during the manufacture or testing of the specimens, or else the poor result might be due to the difficulties involved in attaching and vulcanizing of a thin foil layer of rubber to a steel bar. The alternative of using liquid rubber and a mould when doing the vulcanization requires the manufacture of a mould, but makes it probably easier to get a high and uniform strength. The observation of small spots of a brown/red substance, probably rust, in the rubber-to-steel interface fracture area suggests that the steel surface during some period had corroded to some extent. It might be that the substance observed is related to the acid rinsing of the rubber foil rods. The time from rinsing with acid and water to testing was about 1 year. During this period the specimens were stored indoors at conditions that normally don't give any rust on a naked and clean steel surface.

Also the long duration of load performance tests of the glued-in rods gave poor results. Here also the reference tests with conventionally glued rods gave poor results and worse than the rubber foil specimens. The reason for these results is not known. The results contradict other tests of the long duration of load strength of conventionally glued-in rods tested at the same testing site at about the same time.

8.3 General

This report has been limited to presentation of an experimental study. Experimental tests give information that is valuable from several points of view, including information for calibration or verification of theoretical models. Various theoretical models and methods are conceivable. For analysis of joint stiffness and joint strength, a 3D lap joint finite element calculation model is presented in (Gustafsson, 2006). A 2D lap joint model and a corresponding set of explicit equations for calculation of the stresses in the bond layer as well as in the wooden parts that are joined are presented in (Gustafsson, 2007). Modeling of the strength of glued-in rods is dealt with in i.a. (Gustafsson and Serrano, 2001).

The present and the few previous experimental tests of full size rubber foil adhesive joints are quite positive with the exception for some of the results of the tests of glued-in rods. Further development and research can therefore be anticipated, including the choice of rubber for various applications. An advantage of the present choice of rubber (SBR) is low price. Also natural rubber has a low price and in addition somewhat better mechanical properties, but is somewhat more sensitive to use in high temperature environments. If going up somewhat in price, CR rubber (chloroprene) is an alternative to SBR, CR having better resistance to ozone exposure and a service temperature range from about -45°C to about $+120^{\circ}\text{C}$, while the corresponding range for SBR is about -45°C to about $+95^{\circ}\text{C}$ (Edshammar, 2003). In view of observations made in the present study, future investigations could include measures for better strength and avoidance of fracture in the rubber-to-steel rod interface.

Depending on the field of application considered, also the following issues can be relevant to study: a) the long time service reliability, that is the durability and long time loading strength, b) fire and other high temperature issues, in particular in the case of unprotected steel adherends, c) manufacture and construction process issues, d) strength and stiffness design calculation methods, e) listing of applications and new design possibilities that the present new type of joining makes possible, and f) test application in an actual wood constructions or construction element.

References

Björnsson, Peter and Danielsson, Henrik, 2006: "Strength and Creep Analysis of Glued Rubber Foil Timber Joints", Master thesis TVSM-5137, Div. of Structural Mechanics, Lund University, Sweden.

Edshammar, Lars-Erik, 2003, "Gummimaterials egenskaper", Plastforum nummer 14/2003 Del II.

Gustafsson, Per Johan, and Enquist, Bertil, 1988: "Träbalks hållfasthet vid rätvinklig urtagning", Report TVSM-7042, Division of Structural Mechanics, Lund University, Sweden

Gustafsson, Per Johan, and Serrano, Erik, 2001: "Glued-in Rods for Timber Structures - Development of a Calculation Model", Report TVSM-3056, Division of Structural Mechanics, Lund University, Sweden

Gustafsson, Per Johan, 2006: "A Structural Joint and Support Finite Element", Report TVSM-7143, Division of Structural Mechanics, Lund University, Sweden

Gustafsson, Per Johan, 2007: "Stress Equations for 2D lap joints with a Flexible Bond Layer", Report TVSM-7148, Division of Structural Mechanics, Lund University, Sweden

Wikström, Magnus, 2006a, "Studies of Rubber Based Joints in Laminated Wood", Master thesis, Department of Chemistry, KTH, and Casco Products AB, Stockholm.

Wikström, Magnus, 2006b: "High Capacity Rubber Type Type Joints - Manufacturing of Full Scale Joints", Casco Adhesives, Stockholm.

Appendix: Manufacturing of full scale joints

High Capacity Rubber Type Joints

Manufacturing of Full Scale Joints

by

Magnus Wikström, Casco Adhesives, 2006



High Capacity Rubber Type Joints

Manufacturing of Full Scale Joints



Magnus Wikström

Casco Adhesives
2006

Abstract

As a part of the project “Innovative design, a new strength paradigm for joints, QA and reliability for long span constructions” a study has been carried out on adhesive joints of rubber sheets glued between layers of wood or steel substrates, see *figure 1*¹. The substrates were glulam-glulam, glulam-LVL (Kerto-Q), glulam-steel plates or glulam-steel rods. The adhesives were two-component polyurethanes and the rubber was a SBR-type (styrene-butadiene-rubber).

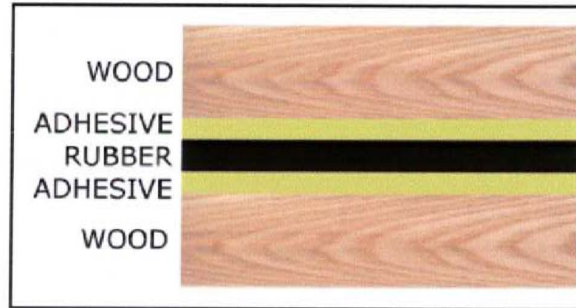

Figure 1. Structure of the rubber joint.

The layer of rubber makes the joint somewhat flexible and makes the stresses acting across the bond layer uniform. This means that the entire bond area is made active in carrying the load, which in turn means that the load carrying capacity of the joint can be made very high. Also in the case of impact loading, the capacity of a joint can be made very high by means of the thin rubber layer.

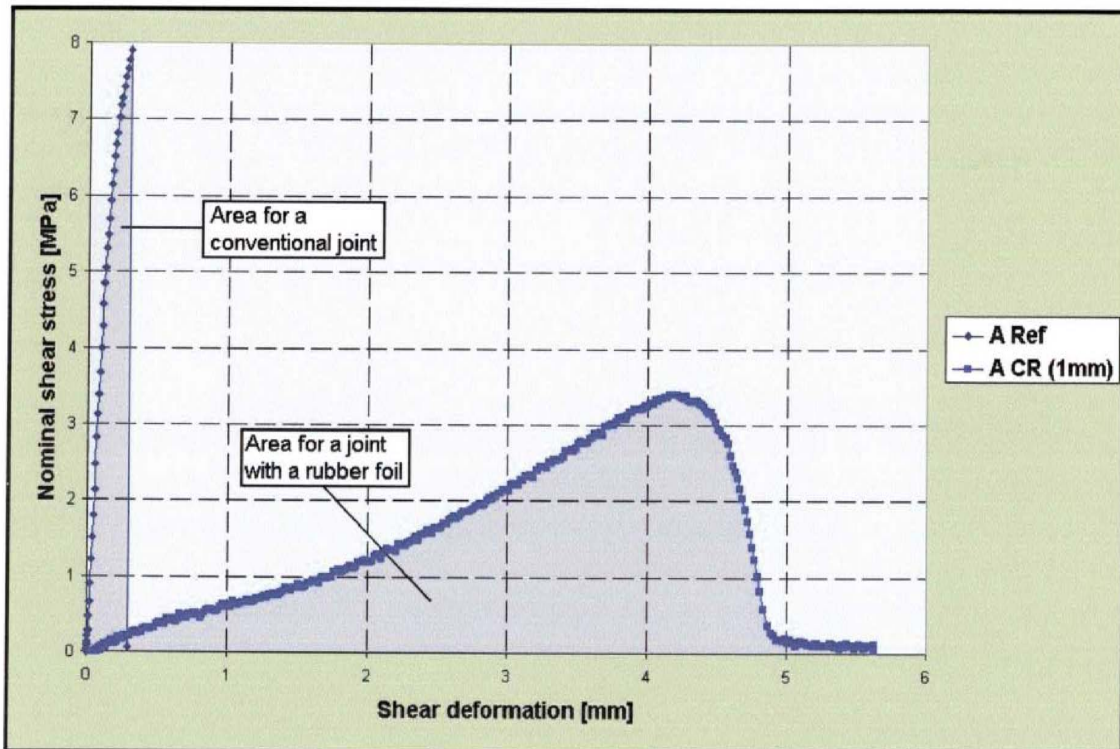

Figure 2. Comparison between a conventional joint (A Ref) and a joint with a rubber foil (A CR 1mm).

¹ Danielsson H., Björnsson B., *Strength and Creep Analysis of Glued Rubber Foil Timber Joints*. Masters Thesis, Lund University, Division of Structural Mechanics 2005.

High load capacity in static loading and impact loading can be achieved even if the local shear strength of the bond layer may be lower than of a conventional bond layer made up of a stiff glue. *Figure 2²* shows local shear stress versus shear deformation of a conventional bond layer and of a rubber type glued bond layer. The area under a curve represents the fracture energy of the bond (energy/area).

The rubber joint can also be used for damping movements in constructions that are allowed to flex and move at some extent. This can be used as a construction material of houses in areas where earthquakes or other movements in the ground are common, in flexible furniture, in floors where the boundary line of the joint is exposed to shear forces or even in drumsticks to lower the sound.

The problem of constructing an element like this is mainly to glue the rubber to the substrate. Many rubbers have very low surface energy which makes them hard to glue. As long as the adhesive has lower surface energy than the rubber there is no problem, but in many cases the relationship is the opposite and poor adhesion, or no adhesion at all, follows. The result is a weak joint with adhesive failure.

To solve this problem you can either modify the surface of the rubber or modify the adhesives and in this project the rubber surface has been modified. The substrate surfaces were ground with sand paper and etched with concentrated sulphuric acid.

The manufacturing of the test specimens were carried out at Moelven Töreboda AB located in Töreboda, Sweden, and at Casco Adhesives located in Stockholm, Sweden, from January to March 2006. For joint types, see "*Sammanställning av gummilimförogprovkroppar / Per Johan Gustafsson, 2005-12-07*" for a closer description.

The testing of the specimens is going to be carried out at LTH in Lund, Sweden, and at Statens Provningsanstalt in Borås, Sweden, in April and May 2006.

² Wikström M., *Studies of Rubber Based Joints in Laminated Wood*. Masters Thesis, KTH Stockholm, Department of Chemistry 2006.

Provkroppar

Provkropparnas geometri och numrering anges i den bilagda sammanställningen ”*Sammanställning av gummilimfogprovkroppar / Per Johan Gustafsson, 2005-12-07*”. Provkroppsserierna 6-10, som avser provkroppar med inlimmade stänger, modifierades vad avser håldiametrar och kompletterades med provkroppar med inlimmade gängade stänger enligt *tabell 2*.

Tillverkningen av provkropparna ägde rum mellan januari – mars 2006 på Moelven Töreboda AB:s limträfabrik i Töreboda och på Casco Adhesives laboratorium i Stockholm.

Material

Lim

Samtliga limsystem i projektet var av typen 2-komponents polyuretanlim. De använda limmen för respektive provkroppsserie anges i *tabell 1*.

Provkroppsserie	Typ	Lim (provad fog)	Lim (mothåll)	Övrigt
1-3	Limträ-limträ	SikaForce 7710 + härdare 7020	-	-
4-5	Limträ-Kerto	SikaForce 7710 + härdare 7020	-	Spik 4,0 x 75mm
6a,7a,8a,9a,10a	Inlimmad slät stång	SikaForce 7710 + härdare 7020	SikaForce 1897 + härdare 1806	-
6b,7b,8b,9b,10b	Inlimmad vulkad stång	SikaForce 7710 + härdare 7020	SikaForce 1897 + härdare 1806	-
6c,7c,8c,9c,10c	Inlimmad gängad stång	Purbond CR 421 (lim+härdare)	SikaForce 1897 + härdare 1806	-
11a	Pålimmad dragplatta	SikaForce 7710 + härdare 7020	SikaForce 1897 + härdare 1806	Teflonfolie och spik 4,0 x 60mm
11b	Pålimmad dragplatta	SikaForce 7710 + härdare 7020	SikaForce 1897 + härdare 1806	-
11c	Pålimmad dragplatta	Purbond CR 421 (lim+härdare)	SikaForce 1897 + härdare 1806	Spik 4,0 x 60mm
12-13	Inlimmad dragplatta	SikaForce 7710 + härdare 7020	-	-
14	Pålimmad förankringsplatta	SikaForce 7710 + härdare 7020	-	-

Tabell 1. Limsystem.

SikaForce 7710 + härdare 7020 (Gick under beteckningen SikaForce 1899 + härdare 1821 vid projektets start.) användes till alla fogar som skulle utvärderas, där limning ingick, med undantag för provkroppar av serie 6-10 typ C.

SikaForce 1897 + härdare 1806 användes till inlimning av gängade stänger där hålen hade mindre diameter än själva stängerna (Provkroppar av serie 6-10, undre stänger/mothållssidan.).

Purbond CR 421 användes till fogarna med gängade stänger där hålen hade 1 mm större diameter än själva stängerna (Provkroppar av serie 6-10 modell C, övre stänger.). Limsystemet är godkänt enligt SITAC Typgodkännandebevis 1396/78 för inlimning av stänger.

Gummi

Gummisorten för samtliga provtyper var styren-butadiengummi (SBR 6160367) av hårdheten 60°Shore och med tjockleken 1,0-1,2 mm för gummi vulkat mot stål och med tjockleken 1,3-1,5 mm för gummidukarna. Gummit är framställt och levererat av Metso Minerals i Ersmark. För ytterligare information se *bilaga 1*. 25m² gummiduk beställdes och löpbredden var ca 50 cm.

Trä

Till alla typer av provkroppar användes limträbalkar som levererades av Moelven Töreboda AB och till provkroppar av serie 4-5 användes även fanerträskivor (Kerto-Q) från Finnforest. För dimensioner, se ”Sammanställning av gummilimföprovkroppar / Per Johan Gustafsson, 2005-12-07”.

Inlimmade stålstänger

Stålet var av typen höghållfasthetsstål med en flytspänning (0.2% gräns) högre än 800 MPa. Till provsidan på provkropparna användes tre olika modeller av stänger:

- släta
- gängade
- gummibelagda/vulkaniserade släta stänger

De släta stångarna och de stänger som skulle vulkaniseras levererades av SFS Intec till Metso Minerals. Vulkaniseringen av en del av de släta stängarna gjordes av Metso Minerals. De gängade stängarna fanns på plats i Töreboda.

Till mothållssidan på provkropparna användes gängade stänger av två olika diametrar, där stängerna med diametern 30mm kom från SFS Intec via Metso Minerals och de med diametern 24mm kom från Töreboda.

En sammanställning av de olika stängernas utförande och diametrar samt de i limträet borrade hålens diametrar finns i *Tabell 2*.

Provkropp-serie	Typ	Provad stång: Stål-/total-/håldiameter (mm)	Mothållstång Stål-/håldiameter (mm)
6a, 7a, 8a, 9a	Inlimmad slät stång	18.3 / 18.3 / 20	M24 / 22
6b, 7b, 8b, 9b	Inlimmad vulkad stång	18.3 / ~20.5 / 21	M30 / 28
6c, 7c, 8c, 9c	Inlimmad gängad stång	M20 / M20 / 21	M30 / 28
10a	Inlimmad slät stång	14.6 / 14.6 / 16	M24 / 22
10b	Inlimmad vulkad stång	14.6 / 16.8 / 18	M30 / 28
10c	Inlimmad gängad stång	M16 / M16 / 17	M30 / 28

Tabell 2. Inlimmade stänger och håldiameter.

Stålplattor

Stålet i plattorna betecknas SS-2132 (flytspänning 350 MPa).

De släta stålplattorna och de plattor som skulle vulkaniseras levererades av SFS Intec till Metso Minerals. Vulkaniseringen av en del av plattorna gjordes av Metso Minerals. Teflonduken som användes i provserie 11a levererades av Analyscentrum, Stockholm.

Tillvägagångssätt

Syrabad

För syrabehandlingen av gummiytorna användes koncentrerad svavelsyra (96%, rumstemp, prod.nr. 92992) som levererades från Casco Adhesives, Kristinehamn, och behållarna som användes var tillverkade av polypropen eller glas beroende på erforderlig storlek.

Vattenbad

För att möjliggöra syrabehandling av gummi krävdes att en sköljningsanordning av tillräckligt stora dimensioner kunde användas. Två stora syrabeständiga plastbehållare, tillverkade av polypropen, införskaffades på Clas Ohlsson och förseddes med krananordning och slanganslutningar, se *figur 3*. Till dessa anslöts kommunalt vatten via en vanlig vattenkran som möjliggjorde fortgående utbyte av vatten i behållarna.



Figur 3. Vattenbad (till vänster och i mitten) och syrabad (till höger).

Preparering av gummidukar och gummibelagda stångar i Nacka

1. Gummidukarna, se *figur 4*, klipptes i samma dimensioner som de föreslagna provkropparna plus ett par extra centimeter för eventuella variationer i virkesstorlek.
2. Gummimaterialen borstades under rinnande vatten för att ta bort en del restprodukter från framställningen.
3. Ruggades med cirkelgående slipmaskin utrustad med NAXO 100 sandpapper,
4. Tvättades med etanol.
5. Betades i konc. svavelsyra (96%, 22°C) under 30 sekunder.
6. Sköljdes i vattenbad 15-30 min.
7. Lades på pappersbädd för att torka.



Figur 4. Gummidukar, obehandlade.

Förvaring innan limning

Efter prepareringen av gummidukarna lades de ihop till ett paket och slogs om med papper. Till provkroppsserie 1-4a gjordes dukarna i ordning 1-6 dagar innan limning medan de till serie 4b-5 gjordes i ordning 2-3 veckor innan.

De gummibelagda stängerna och plattorna förvarades efter preparering öppet i ett plastkärl. Prepareringen utfördes 2-3 veckor innan limning.

Trä, gummi, stålstänger (med och utan gummi), lim och härdare förvarades i Törebodas B-hall där temperaturen var 20°C och luftfuktigheten 50%.

Limning av provkropparna i Töreboda

Fogar med gummiduk (limträ-limträ, limträ-LVL): (Provkroppar serie 1-5)

- Träsubstraten hyvlandes, sågades eller sandpapprades inom 24 timmar före limning.
- De behandlade gummidukarna sköljdes av med etanol för att få bort föroreningar/damm och hängdes upp på torkställning en kort stund före limning, alternativt torkades med tryckluft.
- Gummidukarna var sedan tidigare tillskurna så att det fanns ca 2 cm extra på längd resp. bredd vid eventuell variation på substratens mått. Överflödigt gummi skars bort.
- Limmängden vägdes inte upp, utan lades på tills det var helt täckande utan att det fanns överflöd på substraten (uppskattningsvis 200g/m²)
- Limmet applicerades på träsubstraten och ej på gummidukarna.
- Limmet blandades till precis innan applicering. På provserie 1 och 2 limmades 3-4 fogar med samma limblandning. För provserie 3, 4a och 5 blandades nytt lim för varje fog. För provserie 4b blandades nytt lim för varje provkropp.
- Fogarna utsattes för presstryck m.h.a. tvingar eller limknektar som skruvades/spändes för hand, se *figur 5*. För provserie 1 pressades 3-4 prover samtidigt med samma limknektar, medan för provserie 2-5 pressades varje fog individuellt. För provserie 4-5 limmades fogarna och fixerades med tvingar innan spikning skedde. Spikningen utfördes med spikpistol. Därefter flyttades tvingarna och resten av spikarna sattes fast.
- Limmet fick härda över natt i Törebodas B-hall (förhållanden – se ovan). Efter härdning släpptes presstrycket och provkropparna förvarades sedan i samma hall, se *figur 6*.



Figur 5. Presstryck m.h.a. tvingar.



Figur 6. Förvaring av färdiga provkroppar (3c) på pallbockar.

Inlimmade stänger: (Provkroppar serie 6-10)

- Vulkningen av gummit mot stålet utfördes av Metso Minerals, Skellefteå.
- Substraten borrades senast 24 timmar innan limning. Borrningen utfördes manuellt med vattenpassförsedda bormaskiner. Provkropparna var antingen fastspända horisontellt på pallbockar eller fastkilade vertikalt i en egentillverkad ställning beroende storlek. Träborrharna fanns i storlekar med jämnt antal mm. Där håldiametern var av udda antal mm användes först träborrar och sedan metallborrar. För dimensioner på borrhål, se *tabell 2*.
- Borrhålen blåstes ur med tryckluft strax innan limning.
- De släta och gummibelagda stängerna sköljdes av med etanol för att få bort föroreningar/damm och torkades med tryckluft en kort stund före limning. De gängade stängerna limmades utan behandling.
- Lim och härdare blandades till precis innan limning. 4-8 fogar limmades per limblandning.
- Övre hål: Limmängden vägdes inte upp utan applicerades tills det fanns så mycket lim att överflödigt lim trycktes ut ur hålet när stängerna applicerades. Provkropparna restes lodrätt för att härdning skulle kunna ske utan större ått någon sida. Stängerna pressades ned med kroppstyngd.
- Nedre hål: För att få in limmet i borrhålen användes en ca 1m lång järnstång som doppats i lim, se *figur 7*. Lim applicerades även direkt på stängerna för bättre spridning. De gängade stängerna applicerades med en maskin som skruvar in stängerna i provkroppen, se *figur 8*.
- Limmet fick härda över natt, sedan lades de vågrätt för förvaring, se *figur 9*.



Figur 7. Applicering av lim, inlimmade stänger.



Figur 8. Applicering av gängade stänger.



Figur 9. Förvaring av inlimmade stänger.

På- och inlimmade dragplattor samt pålimmade förankringsplattor: (Provkroppar serie 11-14)

- Se tillvägagångssätt för *Fogar med gummiduk*.
- Vulkningen av gummit mot stålet utfördes av Metso Minerals, Skellefteå.



Figur 10. Förvaring av provkroppar från serie 11-14.

Tänkbara felkällor:

- Variationer i material.
 - Variationer i limningarna.
 - Gummilagring
 - Olika långa tider mellan limapplicering och presstryck
 - Presstryck
 - Sned montering
 - Stänger inte helt centrerade
 - Otillräcklig limmängd (mager limning) – inträffade för en del av mothållslimfogarna
-