



# LUND UNIVERSITY

## Angle-resolved time-of-flight spectroscopy applied to multi-bunch operation at MAX-lab: a design study

Stråhlman, Christian; Sankari, Rami; Lundqvist, Måns; Öhrwall, Gunnar; Ovsyannikov, Ruslan; Svensson, Svante; Mårtensson, Nils; Nyholm, Ralf

*Published in:*  
IOP Conference Series

*DOI:*  
[10.1088/1742-6596/425/9/092011](https://doi.org/10.1088/1742-6596/425/9/092011)

2013

[Link to publication](#)

*Citation for published version (APA):*  
Stråhlman, C., Sankari, R., Lundqvist, M., Öhrwall, G., Ovsyannikov, R., Svensson, S., Mårtensson, N., & Nyholm, R. (2013). Angle-resolved time-of-flight spectroscopy applied to multi-bunch operation at MAX-lab: a design study. In *IOP Conference Series* (Vol. 425). IOP Publishing. <https://doi.org/10.1088/1742-6596/425/9/092011>

*Total number of authors:*  
8

### General rights

Unless other specific re-use rights are stated the following general rights apply:  
Copyright and moral rights for the publications made accessible in the public portal are retained by the authors and/or other copyright owners and it is a condition of accessing publications that users recognise and abide by the legal requirements associated with these rights.

- Users may download and print one copy of any publication from the public portal for the purpose of private study or research.
- You may not further distribute the material or use it for any profit-making activity or commercial gain
- You may freely distribute the URL identifying the publication in the public portal

Read more about Creative commons licenses: <https://creativecommons.org/licenses/>

### Take down policy

If you believe that this document breaches copyright please contact us providing details, and we will remove access to the work immediately and investigate your claim.

LUND UNIVERSITY

PO Box 117  
221 00 Lund  
+46 46-222 00 00

# Angle-resolved time-of-flight spectroscopy applied to multi-bunch operation at MAX-lab: a design study

C Stråhlman<sup>1</sup>, R Sankari<sup>1</sup>, M Lundqvist<sup>2</sup>, G Öhrwall<sup>1</sup>,  
R Ovsyannikov<sup>3</sup>, S Svensson<sup>3,4</sup>, N Mårtensson<sup>4</sup>, R Nyholm<sup>1</sup>

<sup>1</sup> MAX IV Laboratory, Lund University, P.O. Box 118, SE-22100 Lund, Sweden

<sup>2</sup> VG Scienta AB, P.O. Box 15120, SE-750 15 Uppsala, Sweden

<sup>3</sup> Helmholtz-Zentrum Berlin, Albert-Einstein-Straße 15, D-12489 Berlin, Germany

<sup>4</sup> Dept. of Physics and Astronomy, Uppsala University, P.O. Box 521, SE-75121 Uppsala, Sweden

E-mail: [Christian.Strahlman@maxlab.lu.se](mailto:Christian.Strahlman@maxlab.lu.se)

**Abstract.** Angle-resolved time-of-flight (ARTOF) spectrometers have found use in a number of applications, including ARPES. However, the fundamental requirement of an external start trigger matching the read-out time of the instrument limits its usability at many storage rings. Hitherto all reported experiments have been performed at storage rings capable of running in single-bunch mode. To eliminate this restriction, we propose a method where a pulsed electronic gate is introduced to allow for ARTOF usage at normal multi-bunch operation of the MAX II storage ring. This paper will show the working principle and outline the design for this technique.

## 1. Introduction

Angular resolved photoelectron spectroscopy (ARPES) has become a powerful tool in many applications. In the field of band-mapping of materials, the technique has had particular impact. The dominating instrument for such experiments has been the hemispherical deflector electron energy analyzer (HDA). Recent development of electron time-of-flight (TOF) type analyzers have made them cover ground in this area [1]. Both types have proven high energy resolution, thus allowing detailed studies of electronic structure. A significant trend has been the extension to simultaneous measurements of all momentum components of the electron, via the energy and angular distribution. In this spirit, a new energy and angle resolving electron spectrometer, the Scienta ARTOF 10k, has been recently developed based on angle-resolved electron time-of-flight (ARTOF) [2]. The principles behind this detection system have been described in detail by Wannberg [1]. The ARTOF spectrometer consists of a many-element electron lens and a position-sensitive detector. With the aid of simulations, the lens can be set up so that each combination of TOF and hit position can be determined to correspond to a point in 3D momentum space.

ARTOF instruments have so far been designed to operate at pulsed sources of X-rays and VUV-radiation with a pulse frequency in the order of 1 MHz, corresponding to 1  $\mu$ s spacing between light pulses. This prerequisite poses a fundamental restriction compared to the HDA, namely that the start trigger must be external [1]. So far the use of electron TOF at synchrotrons has been restricted to facilities with single-bunch operation. Still, multi-bunch operation

is far more common at synchrotron radiation facilities, as most users exploit the light as a high intensity quasi-continuous beam. Following demands for time resolved experiments, some facilities are able to operate in more exotic modes, such as single-bunch and hybrid modes (see e.g. BESSY II [3]). The availability of single-bunch operations is however quite limited. To enable for increased use of TOF-based techniques, it is necessary to develop a method where the ARTOF spectrometer can be used under normal multi-bunch operation. The most common approach to decrease the undesired repetition rates in storage rings has been mechanical choppers which filter out a certain fraction of the light pulses (see e.g. [4]). However, no chopping setup has been fast enough to filter out single pulses from the multi-bunch light pulse pattern.

We propose instead a method where an electronic gate is implemented to protect the spectrometer from undesired electrons. The setup should allow for the electrons originating from one single light pulse to reach the spectrometer and propagate undisturbed to the spectrometer detector. All other electrons should be deflected. In the following we shall show that an electronic gate can mimic single-bunch temporal structure under normal multi-bunch operation.

## 2. 100 MHz multi-bunch operation at MAX II

The MAX II storage ring has been in operation since 1997. Since 2002, it has operated on a 100 MHz RF system [5]. The filling pattern of MAX II today is homogeneous with equal and equidistant electron bunches (10 ns). The 100 MHz concept has been preserved for the new MAX IV synchrotron light facility, which is now been built in Lund, Sweden. The MAX IV project will utilize a time structure in normal operation equal to that of MAX II [6]. The operating frequency of MAX II (and MAX IV) provides us with an advantage compared to storage rings with 500 MHz RF systems since we have a relatively long 10 ns intermediate time between light pulses.

## 3. Design considerations

The conceptual design of our gate is showed in Fig. 1. In simulations we have used the ARTOF 10k [2] as a reference instrument, although the principle stands for all electron spectrometers with timing constraints. For this spectrometer, the focal distance of the lens is 40 mm. Our proposed gate consists of two consecutive high transmission meshes placed in front of the first lens element. A sufficient negative potential is applied to the mesh closest to the sample. The purpose of this gating potential is to deflect all electrons away from the lens when the gate is 'closed'. Simulations performed with the SIMION software [7] predict a required gating potential given by  $V_{\text{gate}}[\text{V}] = 1.3 \cdot E_{\text{elec,max}}[\text{eV}]$ , where  $E_{\text{elec,max}}$  is the highest expected electron kinetic energy. The second mesh, which is grounded, has two functions: Firstly, it protects the spectrometer from the gating potential, whereas otherwise the gating potential would leak into the lens and disturb the focus. Secondly, as shall be shown, it increases the available ramp-up time of the gating potential. When the gate is closed, no electrons from the interaction region are able to reach the spectrometer. To open the gate, the potential is reduced to zero, thus allowing for undisturbed passage of electrons.

The optimal timing scheme of the gate depends heavily on the electron energy to be measured. With the 100 MHz pulsing of light, energetic electrons are ejected from the sample every 10 ns. The distance traveled by a non-relativistic electron in free space is given by the equation  $d[\text{mm}] = 0.59 \cdot t[\text{ns}] \cdot \sqrt{E_{\text{elec}}[\text{eV}]}$ . Fig. 2 show the restrictions on gate timing. The maximum fall time equals the pulse separation 10 ns, while the rise time depend mainly on the energies of the electrons. Fast electrons ( $>100$  eV) will pass the gate quickly and the available rise time is 9 ns. For 10 eV electrons, the required passing time is longer and available rise time is reduced to 7 ns. Hence, spectroscopy with low electron energies put a tougher constraint on the rise time than higher energies. At the same time, lower electron energies require lower shielding potential, which is easier to reach in shorter time.

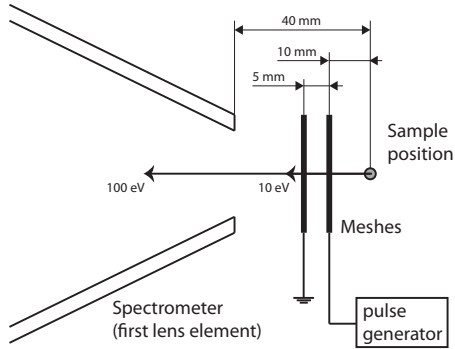

**Figure 1.** The conceptual design of the electronic gate for ARTOF 10k focusing conditions. The mesh closest to the sample is fed by fast pulse generation. The second mesh shields the entrance to the spectrometer from the gating potential. We have indicated the distance traveled by a 10 eV and a 100 eV electron in 10 ns.

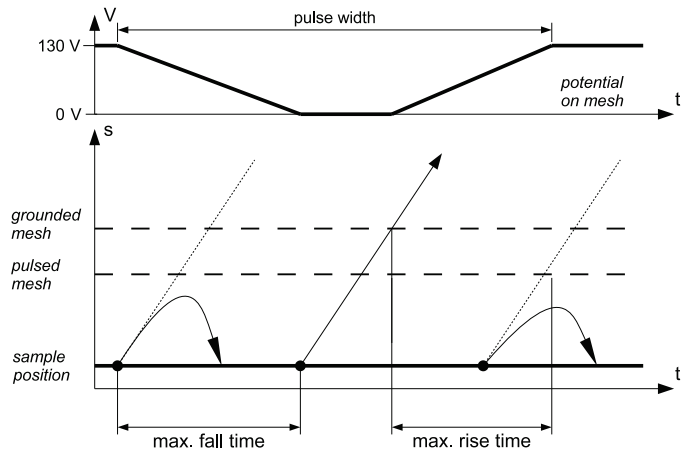

**Figure 2.** Timing principle for the gate in a 2D time-space-diagram together with required gating potential. The tilted lines indicate propagation of mono-energetic electrons through the gate. The first and third electron should be deflected, while the second should pass the gate. Mesh potential is given for 100 eV electrons.

There is a practical lower limit for the electron energies which can be gated. Below 10 eV, temporal overlapping of adjacent electron bursts start to become an issue. For MAX II standard operation the practical lower limit should thus be slightly below 10 eV. One should in this case make use of the ARTOF 10k low energy cut-off, which will filter out low-energy electrons and any secondary electron which would reside in the chamber [2].

In present simulations the gating meshes are separated by 5mm, whereas the pulsed mesh is placed 10 mm from the sample. It is preferential to put the gate as close to the sample as possible. The first reason for this is that a wider energy range of electrons is allowed, since the time separation of electrons are smaller. This is particularly relevant for low energy electrons. The second reason is that the usability of electron spectrometers, and particular ARTOF spectrometers, fully relies on our ability to predict the electron trajectories through the lens. The inclusion of the second mesh constitutes a disturbance to the lens focus which decreases with increasing distance.

#### 4. Pulse generation

The use of pulse generators to gate electrons and ions is very common in spectroscopy. However, they are normally operated in the kHz regime. Here, we should operate in 1 MHz frequency, addressing the dead time of the ARTOF (1  $\mu$ s), required fall and rise times and the overall pulse width (Fig. 2). To maintain good focus of the lens, it is necessary to avoid disturbances from the gating mesh while the gate is open. Ideally, we would have a zero gating potential during the time the electron passes. The signal from the system must thus be sufficiently free from ringing.

High demands are put on the electronic switches. Switches with rise/fall-times down to a few ns sustaining 1 kV and 1 MHz repetition rate are commercially available (see e.g. [8]). The difficulty is to find a device which can provide pulse lengths  $<20$  ns, which is a demand of our setup. We have therefore explored a solution where two parallel switches are deployed, as seen in Fig. 3. Each switch is set up to provide a pulse every 2  $\mu$ s. This frequency is

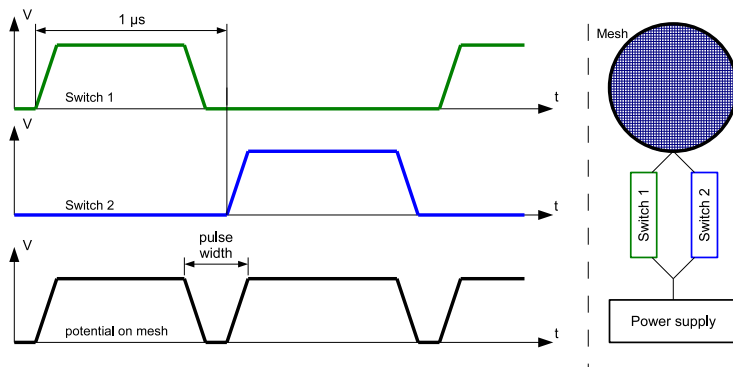

**Figure 3.** Two parallel switches feed the pulser mesh. Each blocking pulse is started by an external trigger determined by the ring frequency. The pulse is set to end after a predetermined time, just before the start of the next blocking pulse. (Graphs are not to scale.)

synchronized to the frequency of the light pulses, which can be extracted with a photo-diode in the experimental chamber, or obtained from a bunch marker from the ring. The switch is set up to close after a predetermined time just long enough to create the  $<20$  ns time-window needed for the application. With this solution, a short time-window can be created without reducing the pulse length of the switch.

Our calculations have shown that the capacitance of the system can be kept below 10 pF when short wiring is utilized. Considering a maximum 500 V gating potential achieved in 3 ns, the peak current is 2 A, which can be well transferred by available feedthroughs. Considerations must also be given to the potential fall of the device to minimize ringing during the time which the gate is open. The length of the blocking pulse must be defined within a few ns margin of error.

## 5. Conclusions

We have in this paper shown how an electronic gate can be constructed to allow for time-resolving spectrometers to be used at multi-bunch storage rings. We have discussed how one can mimic single-bunch operation not only by chopping light, but also by blocking ejected electrons from reaching the spectrometer. A setup with a mesh with an applied pulsed blocking potential, in conjunction with a second shielding mesh, have been studied in electrostatic simulations. We have further suggested an electronic setup with two fast switches to overcome inherent restrictions in terms of achieving very short electronic pulses.

## References

- [1] B. Wannberg, Nucl. Instrum. Methods Phys. Res. A **601**, 182 (2009).
- [2] G. Öhrwall *et al.*, J. Electron Spectrosc. Relat. Phenom. **183**, 125 (2011).
- [3] *Operating Modi BESSY II* ([http://www.helmholtz-berlin.de/forschung/grossgeraete/betrieb-beschleuniger/betriebsmodi\\_en.html](http://www.helmholtz-berlin.de/forschung/grossgeraete/betrieb-beschleuniger/betriebsmodi_en.html)).
- [4] S. Plogmaker *et al.*, Rev. Sci. Instrum. **83**, 013115 (2012).
- [5] Å. Andersson, M. Bergqvist, M. Eriksson, L. Malmgren, and L. Thånell, The 100 mhz rf system for max-ii and max-iii, in *Proceedings of the 8th European Particle Accelerator Conference*, pp. 2118–2120, European Physical Society Interdivisional Group on Accelerators (EPS-IGA) and CERN, 2002.
- [6] *Detailed Design Report on the MAX IV Facility*, 1 ed. (<https://www.maxlab.lu.se/node/1136>, 2012).
- [7] <http://simion.com/>.
- [8] *BEHLKE FSWP 51-02 product sheet* ([http://www.behlke.com/pdf/fswp%2091-01\\_rs.pdf](http://www.behlke.com/pdf/fswp%2091-01_rs.pdf), 2012-11-27).