



LUND UNIVERSITY

LCCC Workshop on Process Control

Johnsson, Charlotta; Hägglund, Tore; Nilsson, Bernt; Soltesz, Kristian; Westin, Eva

2016

Document Version:

Publisher's PDF, also known as Version of record

[Link to publication](#)

Citation for published version (APA):

Johnsson, C., Hägglund, T., Nilsson, B., Soltesz, K., & Westin, E. (Eds.) (2016). *LCCC Workshop on Process Control*. (Technical Reports TFRT-7649). Department of Automatic Control, Lund Institute of Technology, Lund University.

Total number of authors:

5

General rights

Unless other specific re-use rights are stated the following general rights apply:

Copyright and moral rights for the publications made accessible in the public portal are retained by the authors and/or other copyright owners and it is a condition of accessing publications that users recognise and abide by the legal requirements associated with these rights.

- Users may download and print one copy of any publication from the public portal for the purpose of private study or research.
- You may not further distribute the material or use it for any profit-making activity or commercial gain
- You may freely distribute the URL identifying the publication in the public portal

Read more about Creative commons licenses: <https://creativecommons.org/licenses/>

Take down policy

If you believe that this document breaches copyright please contact us providing details, and we will remove access to the work immediately and investigate your claim.

LUND UNIVERSITY

PO Box 117
221 00 Lund
+46 46-222 00 00

LCCC workshop on Process Control

28–30 September 2016

Pufendorf Institute in Lund

Scientific Committee

Margret Bauer, University of Witwatersrand, South Africa

Don Clark, Schneider Electric, USA

Guy Dumont, University of British Columbia, Canada

Krister Forsman, Perstorp, Sweden

Christos Maravelias, University of Wisconsin-Madison, USA

Stevo Mijanovic, United Technologies Research Center, Ireland

Sigurd Skogestad, Norwegian University of Science and Technology, Norway

Hongye Su, Zhejiang University, China

Organizing Committee

Charlotta Johnsson, Automatic Control, Lund University

Tore Hägglund, Automatic Control, Lund University

Bernt Nilsson, Chemical Engineering, Lund University

Kristian Soltesz, Automatic Control, Lund University

Eva Westin, (administrative coordinator) Automatic Control, Lund University

MAILING ADDRESS

Department of Automatic Control
Lund University
Box 118
SE-221 00 LUND, SWEDEN

VISITING ADDRESS

Institutionen för Reglerteknik
Ole Römers väg 1
232 63 LUND

TELEPHONE

+46 46 222 87 87

FAX

+46 46 13 81 18
Generic e-mail address
control@control.lth.se

WWW

www.lccc.lth.se

Print: Media-Tryck, Lund, Sweden, November 2016

ISSN 0280-5316

ISRN LUTFD2/TFRT--7649--SE

Contents

INTRODUCTION	1
PROGRAM	3
GROUP AND PANEL DISCUSSIONS	5
PARTICIPANTS	10
ABSTRACTS	12
KARL JOHAN ÅSTRÖM	12
Travels in process reality	
SEBASTIAN ENGELL	22
Optimal resource allocation in industrial complexes by distributed optimization and dynamic pricing	
DAVE EMERSON	34
The Power of Context	
HONGYE SU	43
Research on Economic Performance Assessment and Diagnosis of Industrial MPC	
JUNQIANG (JAMES) FAN	56
Control design and verification with physics based models for HVAC/R applications	
DANIEL RIVERA	62
A Process Control Perspective to Managing Production-Inventory Systems: Modeling, Forecasting, and Control	
CHRISTOS MARAVELIAS	73
Online Scheduling: Basics, Paradoxes, and Open Questions	
SIGURD SKOGESTAD	84
A systematic procedure for economic plantwide control	
KRISTER FORSMAN	94
Practical and theoretical aspects of plant wide control for chemical plants	

DON CLARK	105
The IoT of Automation - A Totally New Way to Look at Control and Automation in the Process Industries	
DENNIS BRANDL	110
The Future Control System Environment, as envisioned by the ExxonMobil Next Generation Control System Pilot Project	
MARGRET BAUER	119
Dark data? The use of sensor data in process monitoring and control	
CHRISTOS GEORGAKIS	126
Data-Driven Modeling of Batch Processes: Two Methodological Generalizations of DoE	
MARTIN GUAY	137
Performance improvements in extremum seeking control	
YI CAO	153
Recent Development on Global Self-Optimizing Control	
STEVO MIJANOVIC	161
Model-based Controls and Systems Engineering for Building and Aircraft Systems	
GUY DUMONT	166
Recent advances in paper machine control	

Introduction

ORGANIZATION

The Linnaeus Center for Control of Complex Engineering Systems (LCCC) at Lund University was hosting this workshop on Process Control, in collaboration with the Process Control Centre at Lund University (PICLU). It was held at the Pufendorf Institute in Lund September 28-30 2016, and attended by 60 persons, organisers included.

Speakers to the conference were invited by a committee, with members equally divided between academic and industrial leaders within the field. The committees suggested further speakers, while maintaining the ratio between the mentioned groups.

Upon opening speeches by Viktor Öwall, Dean of the Lund University Faculty of Engineering, Anders Rantzer, LCCC coordinator, and Bernt Nilsson, PICLU centre leader, a plenary talk *Travels in Process Reality* was given by Prof. Karl Johan Åström, Lund University. Subsequent activities comprised single track sessions, interwoven with group discussions, and ample opportunities for less structured interaction, including a dinner at Härkeberga Castle. The outcome of the group discussions served as basis for the last day's panel discussion.

SCIENTIFIC COMMITTEE

Margret Bauer, University of Witwatersrand, South Africa

Don Clark, Schneider Electric, USA

Guy Dumont, University of British Columbia, Canada

Krister Forsman, Perstorp, Sweden

Christos Maravelias, University of Wisconsin-Madison, USA

Stevó Mijanovic, United Technologies Research Center, Ireland

Sigurd Skogestad, Norwegian University of Science and Technology, Norway

Hongye Su, Zhejiang University, China

ORGANIZERS

Charlotta Johnsson, Automatic Control, Lund University

Tore Hägglund, Automatic Control, Lund University

Bernt Nilsson, Chemical Engineering, Lund University

Kristian Soltesz, Automatic Control, Lund University

Eva Westin, (administrative coordinator) Automatic Control, Lund University

TOPICS

The presentation topics were reflective of current trends in research and applications. Common for several of the topics was the address of the complexity, which is inherent to many process control scenarios. Scheduling, plant-wide control, and use of big data were themes common to several of the presentations. These themes were complemented by presentations highlighting relevant use cases and process control technologies.

Program



PROGRAM

LCCC and PICLU September 2016

Process Control Workshop



Wednesday, September 28

08:15 Registration at the Pufendorf Institute

09:00 **Welcoming remarks**

Viktor Öwall - Dean of the Faculty of Engineering, Lund University

Anders Rantzer - Chairman of the LCCC

Bernt Nilsson - Centre Leader of PICLU

09:30 **Travels in process reality**

Karl Johan Åström, Lund University, Sweden

10:00 **Coffee**

10:30 **Optimal resource allocation in industrial complexes by distributed optimization and dynamic pricing**

Sebastian Engell, TU Dortmund, Germany

11:00 **OPC united architecture as a platform for automation**

Dave Emerson, Yokogawa, USA

11:30 **Lunch, served at Tegnér**

13:00 **Research on economic performance assessment and diagnosis of industrial MPC**

Hongye Su, Zhejiang University, China

13:30 **Control design and verification with physics based models for HVAC/R applications**

Junqiang (James) Fan, UTClimate, Controls & Security, USA

14:00 **Coffee**

14:30 **A process control perspective to managing production-inventory systems: modeling, forecasting, and control**

Daniel Rivera, Arizona State University, USA

15:00 **Online scheduling: basics, paradoxes and open questions**

Christos Maravelias, University of Wisconsin-Madison, USA

15:30 **Group discussions until 16:30**



Thursday, September 29

- 09:00** **A systemic procedure for economic plantwide control**
Sigurd Skogestad, Norwegian University of Science and Technology, Norway
- 09:30** **Practical and theoretical aspects of plant wide control for chemical plants**
Krister Forsman, Perstorp AB, Sweden
- 10:00** **Coffee**
- 10:30** **Group Discussions**
- 11:30** **Lunch, served at Tegnér's**
- 13:00** **The IoT of automation - a totally new way to look at control and automation in the process industries**
Don Clark, Schneider Electric, USA
- 13:30** **The Future Control System Environment, as envisioned by the ExxonMobil Next Generation Control System Pilot Project**
Dennis Brandl, BR&L Consulting, USA
- 14:00** **Coffee**
- 14:30** **Dark data? The use of sensor data in process monitoring and control**
Margret Bauer, University of Witwatersrand, South Africa
- 15:00** **Data-driven modeling of batch processes: two methodological generalizations of DoE**
Christos Georgakis, Tufts University, USA
- 15:30** **Group Discussions until 16:45**
- 17:00** **Departure to dinner at Håckeberga Castle**

Friday, September 30

- 09:00** **Performance improvements in extremum seeking control**
Martin Guay, Queen's University, Canada
- 09:30** **Recent Development on global self-optimizing control.**
Yi Cao
- 10:00** **Coffee**
- 10:30** **Model-based Controls and Systems Engineering for Building and Aircraft Systems**
Stevo Mijanovic, United Technologies Research Center, Ireland
- 11:00** **Recent advances in paper machine control**
Guy Dumont, University of British Columbia, Canada
- 11:30** **Lunch, served at Tegnér's**
- 13:00** **Panel summary of group discussions**
- 15:00** **Closing coffee**



Group and Panel Discussions

BREAKOUT SESSIONS

Aim: Over the three days conference, three breakout sessions were organized and run three times. The aim was to create room (in space and time) for discussions and idea-sharings, in a brainstorming, workshop-like atmosphere. All ideas and thoughts were welcomed! At the end of the conference, the collection of ideas and thoughts were presented, and an additional discussion in plenum was held.

When: The three breakout sessions (session 1, 2 and 3) took place at the following times:

- Breakout session 1: Wednesday 15.30–16.30
- Breakout session 2: Thursday 10.30–11.30
- Breakout session 3: Thursday 15.30–16.30

What: At each breakout session, three themes were discussed.

- Theme A: Current challenges
- Theme B: Industry meets academia
- Theme C: Future visions

Who: The attendees, in total 60 individuals, were, divided into three groups, i.e. 20 individuals in each group. During each breakout session, the three themes were discussed, each in a separate location, i.e. each theme was discussed three times, once during each breakout session. In this way each individual had the possibility to contribute to the discussion of each theme. The constellations of individuals in the groups were altered between each breakout session, so that each individual would meet and discuss with as many of the other individuals as possible. The chairperson for each theme remained the same for all breakout sessions.

Outcome: At the summary session, each chairperson presented a summary of what had been discussed during the breakout sessions. The summary is given below.

CURRENT CHALLENGES

In this group, current process control challenges were discussed, with the focus on challenges related to collaboration between industry and academia.

One question was why so few new control concepts developed at universities are transferred to industry. One obvious reason is that many of these concepts are too complicated and not robust enough to be used in practice. It was also pointed out that people in industry tend to be conservative, and want to have a proof of concept before they are willing to accept the new ideas. These proofs of concepts are not only technical, the economical benefits of introducing new concepts are also often required.

It was also argued that people in academia often are bad at “selling” their ideas. It is e.g. important to adapt the language to the industrial audience, which means that many of the mathematical terms used in academia should be avoided.

Another reason for the low transfer of ideas from academia to industry is the lack of incitement. Many universities don't appreciate the industrial collaborations, and people focus on writing papers and increasing h indices. Publish or perish. There is a money making pragmatism in industry, and a paper publishing pragmatism in academia. These separate models do not directly encourage collaborations.

Vendors of control systems are willing to invest in implementation of new ideas and new concepts, but only when they see a desire from end users or a threat from competitors. It means, that if someone in academia would like to see a new idea implemented and used in practice, they should not go directly to the instrument suppliers, but via end users. A proof of concept at end users is crucial.

There were also long discussions about the use of model predictive control, MPC. When MPC is used, there is normally some kind of backup strategy, often based on classical PID control configurations. Places like refineries, that have used MPC for many years, may have the old MPC as backup, if there are people left who understand how it works. Some months after installation, the process will normally have changed so that the models in the MPC have to be updated to retain satisfactory control. If this is not done, it is common that the backup strategy is taking over.

Many PID controllers are in manual or have default settings, but most of the participants seemed to be unaware or unworried about the situation. When the PID controllers are used at a bottom layer under MPC, they are often tuned when the MPC is commissioned, but they are unfortunately not maintained tuned.

There were also discussions about the use of big data. For control purposes, a problem is that it is hard to find sequences of data that can be used for identification and modeling, since most of the data is closed-loop data, meaning that causality may be reversed. One

way is to look for periods when controllers are in manual or when there are setpoint changes. Sampling rate is also important. If the sampling rates of the historical data are too low, the data may be useless for control purposes.

Another problem is that the technology used in automation software is old, often from the 60s and 70s. The systems are clumsy, and hard to use. Very large overhead in terms of engineering hours is required even for simple tasks such as replacing a sensor. Compared to other systems (smart phones for example), there is a huge technological gap, and it is widening. An interesting question is if small companies will break into the market providing a new generation of modern functional DCS systems.

INDUSTRY MEETS ACADEMIA

This group discussed the relation between industry and academia, where the control and process knowledge are, and how this knowledge is transferred between companies and universities. There was often no consensus in the discussions, since the situations often differ between countries.

Some had the opinion that control at the process level is more or less solved today, and that the focus should be on control at higher levels. On the other hand, some disagreed and pointed out that many plants were run in "fire fighting mode", with lots of low-level control problems. They also had the experience that very few advanced controllers such as MPC could be seen, refineries being exceptions.

It was claimed that in US, process knowledge is outsourced to system suppliers, consultants and integrators today. Engineers within the client companies function as project managers. No process engineers are left at the plants. However, at least in Europe the situation is different. Control knowledge may be outsourced, but process engineers are retained and so is the process knowledge. Process engineers are key people. Good MSc projects are often initiated by process engineers at the companies. Chemical engineers make models of the plants, often static. They have good solvers, but these are not for control purposes. Chemical engineers and control engineers should work more together.

The number of personnel is reduced year after year. In the 80s larger companies had technical centers, often with PhDs, that had good contacts with both universities and the industry. These centers were natural links between universities and industries, but many of these centers have unfortunately been reduced or even disappeared.

Offering internship positions in industry would be of mutual benefit to industry and academia. Jointly sponsored projects, such as ERC projects, are good. They help PhDs who have gone to industry to stay in contact with academia, and they help introduce students and faculty to the industrial reality.

In Canada, the attitude of companies has changed during the last decade. It is increasingly difficult to work with industry, since they have a very lean, and often fire fighting mode of operation. They simply have no time for students. In Canada several funding programs require industrial co-funding, as in Europe. It is hard to make potential industrial partners commit to long term involvements (3 years). Industry typically operates on much shorter time scales than academia. It means that many projects are too big for a master project and too small for a PhD project.

Government co-funding in the US is rare outside health and environmental research. There are very few exceptions, and these are typically strongly affiliated with top universities like MIT or Caltech.

Another interesting question is where the academic work stops and the industrial starts. Many good ideas are stopped because everyone thinks that the other part should take one more step. Who is implementing? The best projects are those where the academic partner is following the idea all the way to the final project, including field tests.

Finally, it was claimed that the most successful technology transfer is obtained when people transfer, i.e. when people leave universities, bringing their skills and ideas, and start to work for industrial companies.

FUTURE VISIONS

In this group the task was to discuss Future Visions of Process control and Process Industry. What do we think will happen in the next 10-20 years? What would we like to see happen in the next 10-20 years?

The discussion started with statements like "Nothing has changed the last 15 years, so most probably there will be no changes for the next 10-20 years". After some discussions it was concluded that this statement is believed to be more true for large commodity plants, i.e. facilities where the same product is produced 24/7, 365 days per year. The feeling of what is going to happen for smaller, more flexible facilities with custom made production, was much less static. After discussions about future scenarios for the small flexible facilities, the groups also concluded that several of the proposed changes could also apply for the larger commodity plants.

Small plants were foreseen to become more common (e.g. mini-mills, small pharma plants). These plants will produce only to serve a local geographical area, their production will be highly flexible and custom-tailored (batch size One). Operators will be needed in these plants and they will play an important role in understanding and optimizing product- and production changeovers. For the larger plants, where the production does not need to have the same high degree of flexibility, an increased level of automation will lead to fewer operators and even a possibility for lights-out plants.

Sustainability and lifecycle aspects were also foreseen to become more important in the future. This implies an increased demand for taking care of re-circulation of materials and hence there will be more plants focusing on material handling and able to work on re-used materials.

Also more visionary aspects were discussed such as: use of automated vehicles and drones in the plants. The main focus for drones will initially be on monitoring (of assets and on production and process).

- possibility to have "pokemon-inspired games" for daily or weekly plant inspection tours.
- possibility to use e.g. machine-learning for capturing the context of the plant and the production.
- possibility to have a Plant-Phone, i.e. a phone with which the operator or process-engineer or plant-manager can, by using App-like tools, set up their individual screen etc.
- increased use to augmented reality to instantly access the information needed when e.g. out in the plant.

We will see a higher level of integration and interoperability between the various automation applications, as well as between automation applications and business applications. There will be a shift towards control of business variables instead of control of traditional plant variables. The business variables will help to control the business perspectives of the plant (such as cost per product piece/volume, costs for energy consumption etc), and it will help to identify root-causes when improvements are needed. The business control is also foreseen to become more future oriented and give advices of what ought to be done instead of showing what the passed has looked like.

We will see more applications using wireless technology. Cabling is today a major cost when commissioning a new plant. Once wireless becomes as reliant and fast as today's technologies, it will likely become the default communication mechanism. Also cloud applications will become much more frequently used, once reliability issues have been removed. Initially, cloud applications are foreseen to take care of upgrades, patches, maintenance and diagnostics.

Companies will remain very protective about their models used and their data collected. Computer power will not be a limiting factor in the future.

The groups felt an enthusiasm for the future, a future that we together are forming!

Participants

PARTICIPANTS LCCC and PICLU, September 2016 Process Control Workshop

Mohammed Adlouni	Perstorp AB	mohammed.adlouni@perstorp.com
Muhammad Faisal Aftab	NTNU, Trondheim	muhammad.faisal.aftab@itk.ntnu.no
Niklas Andersson	Lund University	niklas.andersson@chemeng.lth.se
Karl Johan Åström	Lund University	karl_johan.astrom@control.lth.se
Khalid Atta	Luleå Technical University	Khalid.Atta@ltu.se
Jan Peter Axelsson	Vascaia AB	jan.peter.axelsson@vascaia.se
Margret Bauer	University of Witwatersrand	margret.bauer@wits.ac.za
Manuel Berenguel	University of Almería	beren@ual.es
Josefin Berner	Lund University	josefin.berner@control.lth.se
Wolfgang Birk	Luleå Technical University	wolfgang@ltu.se
Anders Blomdell	Lund University	anders.blomdell@control.lth.se
Dennis Brandl	BR&L Consulting	dnbrandl@brlconsulting.com
Yi Cao	Cranfield University	Y.Cao@cranfield.ac.uk
Michelle Chong	Lund University	michelle.chong@control.lth.se
Don Clark	Schneider Electric	don.clark@schneider-electric.com
Guy Dumont	University of British Columbia	guyd@ece.ubc.ca
Dave Emerson	Yokogawa	dave.emerson@us.yokogawa.com
Sebastian Engell	TU Dortmund	sebastian.engell@bei.tu-dortmund.de
Junqiang (James) Fan	UTC Climate, Controls and Security	Junqiang.Fan@carrier.utc.com
Krister Forsman	Perstorp AB	krister.forsman@perstorp.com
Christos Georgakis	Tufts University	Christos.Georgakis@tufts.edu
Giulia Giordano	Lund University	giulia.giordano@control.lth.se
Martin Guay	Queens University	guaym@queensu.ca
José Luis Guzman	University of Almería	joseluis.guzman@ual.es
Tore Hägglund	Lund University	tore.hagglund@control.lth.se
Gabriel Ingesson	Lund University	gabriel.ingesson@control.lth.se
Charlotta Johnsson	Lund University	charlotta.johnsson@control.lth.se
Ola Johnsson	Lund University	ola.johnsson@control.lth.se
John Bagterp Jørgensen	Technical University of Denmark	jbjo@dtu.dk
Per-Ola Larsson	Modelon AB	per-ola.larsson@modelon.com
Anna Lindholm	Modelon AB	anna.lindholm@modelon.com
Peter Lingman	Optimization AB	peter.lingman@optimization.se
Matthieu Lucke	ABB Corporate Research Germany	matthieu.lucke@de.abb.com
Martina Maggio	Lund University	martina.maggio@control.lth.se
Christos Maravelias	University of Wisconsin	christos.maravelias@wisc.edu
Jacob Mejvik	Lund University	jacob@mejvik.se
Stevo Mijanovic	United Technologies	mijanosl@utrc.utc.com
Anders Nilsson	Lund University	anders.nilsson@control.lth.se
Bernt Nilsson	Lund University	Bernt.Nilsson@chemeng.lth.se
Rasmus Olsson	Corebon AB	rasmus.olsson@corebon.com
Anders Rantzer	Lund University	anders.rantzer@control.lth.se
Daniel Rivera	Arizona State University	daniel.rivera@asu.edu
Anton Sellberg	Lund University	anton.sellberg@chemeng.lth.se
Guodong Shao	National Institute of Standards and Technology	gshao@nist.gov
Sigurd Skogestad	NTNU	skoge@ntnu.no
Kristian Soltesz	Lund University	kristian.soltesz@control.lth.se
Hongye Su	Zhejiang University	suhy@supcon.com / hysu@iipc.zju.edu.cn
Alfred Theorin	ABB	alfred.theorin@gmail.com
Olof Troeng	Lund University	olof.troeng@control.lth.se
Stéphane Velut	Modelon AB	stephane.velut@modelon.com
Massimiliano Veronesi	Yokogawa Italia Srl	max.veronesi@it.yokogawa.com
Ramón Vilanova	Universitat Autònoma de Barcelona	Ramon.Vilanova@uab.es
Antonio Visioli	University of Brescia	antonio.visioli@unibs.it
Eva Westin	Lund University	eva.westin@control.lth.se
Torsten Wik	Chalmers	tw@chalmers.se
Lei Xie	Zhejiang University	leix@csc.zju.edu.cn



Abstracts

KARL JOHAN ÅSTRÖM

Travels in process reality

Experiences gained from working on a wide range of control techniques in the process industry are summarized with emphasis on lessons learned and reflections on future development. The techniques encountered include: computer control, PID control, automatic controller tuning, system identification and adaptive control. The experiences are obtained by working with small (NAF and Telemetric), medium sized (AlfaLaval Automation and Satt Control) and large companies (ABB, Billerud, Emerson, Fisher Controls, IBM, MoDo and UTC).



Outline

- Introduction
- Computer Control
- Adaptive Control
- PID Control and Autotuning
- Reflections

Travels in Process Reality

K. J. Aström

Department of Automatic Control, Lund University

K. J. Aström

Travels in Process Reality

Computer Based Process Control

- The scene of 1960
 - Using computers for process control
 - Paradigm shift in control theory
- Port Arthur and RW-300 closed loop control March 15 1959
- Process industries saw potential for improved quality and efficiency
- Computer companies projected large potential markets
- Case studies jointly between computer and process companies
- IBM and the Seven Dwarfs (IBM 70 % market share)
 - IBM Research Yorktown Heights Jack Bertram
 - Mathematics Department Rudolf Kalman
 - The DuPont project Kalman moved to DuPont
 - Jack Bertram took over
 - IBM Development San Jose
- IBM Nordic Laboratory 1960-(1983)-1995 (peak > 200 people)

K. J. Aström

Travels in Process Reality

The Billerud Plant - First Real Encounter



K. J. Aström

Travels in Process Reality

K. J. Aström

Travels in Process Reality

The Billerud-IBM Project 1962-66

- Background
 - Computer control and IBM
 - Computer control and Billerud Trygve Berge and Saab
- Goals
 - Billerud: Exploit computer control for more efficient production
 - IBM: Spectacular case study. Recover prestige!
 - IBM: What is a good computer architecture for process control?
- Tasks - squeeze as much you can into the computer
 - Production Planning
 - Production Supervision
 - Process Control
 - Quality Control
 - Reporting
 - Schedule
- Start April 1963
 - Computer Installed December 1964
 - System identification and on-line control March 1965
 - Full operation September 1966
 - 40 many-years effort in about 3 years

K. J. Aström

Travels in Process Reality

Steady State Regulation

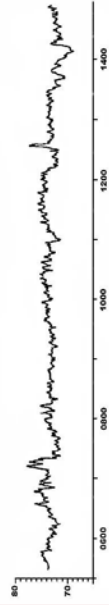

- What can be achieved?
- What are the benefits?
- Small improvements 1% important
- How to model the system
- Physics or experiments
- Stochastic properties important
- Control laws

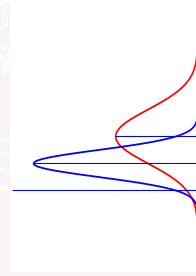

K. J. Aström

Travels in Process Reality

Modeling from Data (Identification)

- Experiments in normal production
- To perturb or not to perturb
- Open or closed loop?
- Maximum Likelihood Method
- Model validation
- 20 min for two-pass compilation of Fortran program!
- Control design
- Skills and experiences

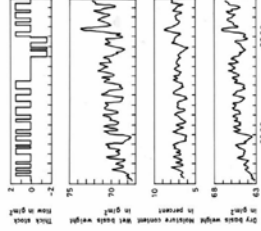

KJÅ and T. Bohlin, Numerical Identification of Linear Dynamic Systems from Normal Operating Records, in Hammond, *Theory of Self-Adaptive Control Systems*, Plenum Press, January 1966.

K. J. Aström

Travels in Process Reality

K. J. Aström

Travels in Process Reality

Minimum Variance Control

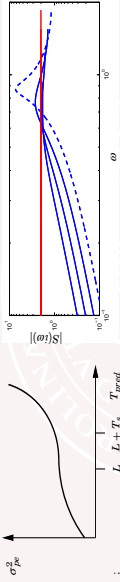

The prediction horizon T_{pred} is the key design variable

- Variance increases with increasing $T_{pred} > L$
- Maximum sensitivity increases with increasing $T_{pred} > L$
- Sampling period T_s gives quantization of T_{pred}
- Rule of thumb: no more than 1 - 4 samples per dead time

KJÅ Computer Control of a Paper Machine - An Application of Linear Stochastic Control Theory, IBM J R&D 11 (1967), pp. 389-405

Experiments

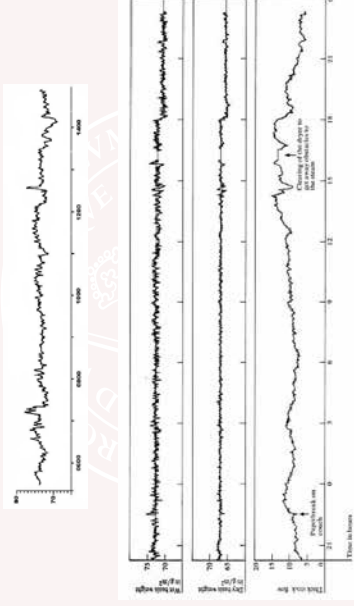

Summary

- Regulation can be done effectively by minimum variance control
 - Easy to validate - moving average
 - Sampling period is the **design variable!**
 - Robustness depends critically on the sampling period
 - The Harris Index
 - Why not adapt?
- The self-tuning regulator (STR) automates identification and minimum variance control in 35 lines of FORTRAN code
- KJÅ & B. Wittenmark On Self-Tuning Regulators, Automatica 9 (1973), 185-199

Lessons Learned

- Value of good leadership: goals, freedom and encouragement
- Be brave and challenge
- Value of experiments in industry - **Industry will be our Lab!**
- Send students to experiment in industry - **credibility**
- System identification - computer control version of frequency response
- Minimum variance control
 - Easy to assess - mean square prediction error - Harris index
 - Easy to test - moving average
 - Prediction horizon T_{pred} is the key design variables
- Importance of embedded computing and software
- Project well documented in IBM reports and a few papers but **we should have written a book!**
- Richard Bellman: if you have done something worthwhile write a book!



Outline

- Introduction
- Computer Control
- Adaptive Control
- PID Control and Autotuning
- Reflections

Paper Machine Control

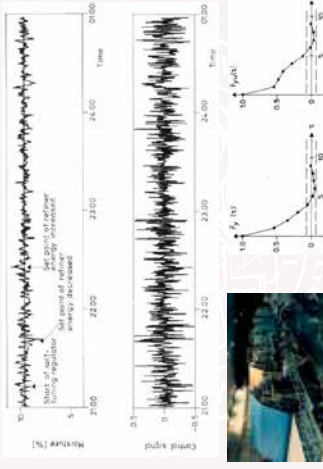

U. Borisson and B. Wittenmark An Industrial Application of a Self-Tuning Regulator, 4th IFAC/IFIP Symposium on Digital Computer Applications to Process Control 1974

ABB

ASEA Novatune G Bengtsson

- ASEA Innovation 1981
- DCS system with STR
- Grew quickly to 30 people and 50 MSEK (internal price) in 1984
- Worked very well because of good people

Incorporated in ABB Master 1984 and later in ABB 800xA

- Difficult to transfer to standard sales and commission workforce (sampling period and prediction horizon)

Made in Sweden

At the beginning of the 70s, the basic theory of adaptive control was developed at the group around professor K. J. Åström at the Lund Institute of Technology in Sweden. At the same time ASEA initiated the first industrial application. This technology is well known throughout the world.

ASEA NOVATUNE is an instrumentation system based on adaptive control.

NOVATUNE

Process Control
with
Adaptive Controllers

NOVATUNE

K. J. Åström
Travels in Process Reality

K. J. Åström
Travels in Process Reality

K. J. Åström
Travels in Process Reality

Industrial Applications

- A number of applications in special areas
- Paper machine control
- Ship steering Kockums
- Rolling mills
- Ore grinding
- Semiconductor manufacturing
- Novatune G Bengtsson
- Tuning of feedforward very successful
- First Control
- Process diagnostics Harris and similar indices



K. J. Åström
Travels in Process Reality

K. J. Åström
Travels in Process Reality

K. J. Åström
Travels in Process Reality

Ship Steering

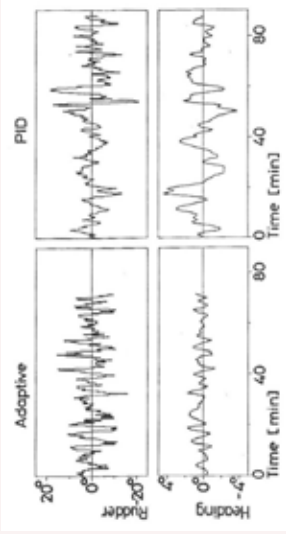

Physics based initialization, 3 % fuel reduction

C. Källström, K.JÅ, N. E. Thorell, J. Eriksson, L. Sten, Adaptive Autopilots for Tankers, *Automatica*, 15 1979, 241-254

K. J. Åström

Travels in Process Reality

Lessons Learned

- Important issues: initialization, excitation, forgetting
- STR very successful in restricted domains
 - Papermachines, rolling mills, ship steering, ore crushers, ...
- Tuning the STR requires insight of computer control, identification and adaptive control
- Novatune was very successful when manufactured, sold and commissioned by a highly competent small team but was not successfully transferred to a large organization
- Never easy to introduce new concepts
- Match system to background and experiences of users
- Important to explain how a system works to the users
- PhD free control
- **The magic black box (STR) is still a pipe dream!**



K. J. Åström

Travels in Process Reality

Control over Networks

- IBM Stockholm - Sandviken 1962 Are you still talking?
- Borisson Syding 1973 Adaptive control of ore crusher Lund Kiruna 1400 km Home made modems Supervision over phone Sampling period 20 s
- Lars Jensen 1973-78 Control of HVDC systems Extensive experiments with networked on-line control Interactive Process Control Language TAC => Schneider

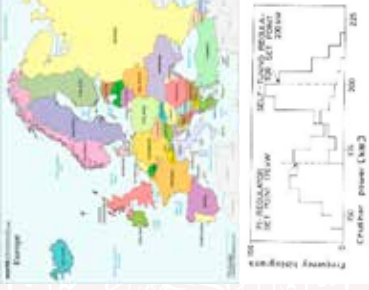

K. J. Åström

Travels in Process Reality

Outline

- Introduction
- Computer Control
- Adaptive Control
- **PID Control and Autotuning**
- Reflections

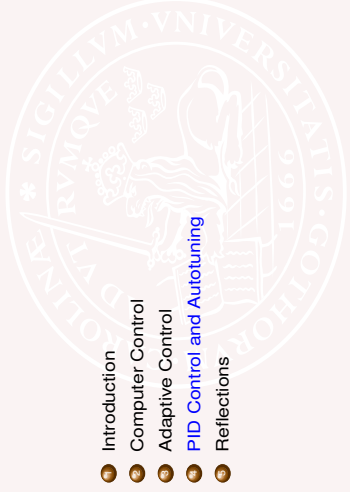

K. J. Åström

Travels in Process Reality

PID Control - The Lund Experience

- Snobbishness and hybrid: PID why bother?
- Telemetric Axel Westrenius 1979
- Mike Sommerfeld and Eurotherm 1979
 - Windup, bumpless transitions, testbatch
- PID really useful but largely neglected in academia
- Auto-tuning with Tore Hägglund
 - Ziegler-Nichols tuning: good idea but bad execution, too little process information only
 - two parameters, bad tuning rule quarter amplitude damping
 - What information is required for PID tuning? How should it be done?
- NAF: S. Larsson, patents, products and books
- Comments from colleagues in academia: Why work on such trivial problems as the PID?



PID Control - Predictions and Facts

- 1982: The ASEA Novatune Team: *PID Control will soon be obsolete*
- 1989: Conference on Model Predictive Control: *Using a PI controller is like driving a car only looking at the rear view mirror: It will soon be replaced by Model Predictive Control.*
- 1993: Bill Bialkowski Emtech pulp and paper: *Average paper mill has 3000-5000 loops, 97% use PI the remaining 3% are PID, adaptive etc. Investment 25 k\$ per loop: 4000*25 k\$=100M\$*
 - 50% works well
 - 25% ineffective
 - 25% dysfunctional
- 2002: Desborough and Miller (Honeywell) *Based on a survey of over 1,000 controllers in the refining, chemicals and pulp and paper industries, 98% of regulatory controllers utilise PID feedback*
- 2016: Sun Li and Lee *Survey of 100 boiler-turbine units in the Guangdong Province in China showed: 94.4% PI, 3.7% PID and 1.9% advanced controllers*

PID Tuning

- What process information is required?
- How can the information be obtained?
- Tuning criteria
 - Load disturbance attenuation
 - Measurement noise
 - Robustness
 - Set point following - set point weighting
- Testbatch
- Can we find correlations to process parameters?
- What are the parameters?

Design of PID Controllers

Insight into design of PID controllers

- Role of FOTD model $P(s) = \frac{K}{1+sT} e^{-sL}$, and test batch
- The normalized time delay: $\tau = \frac{L}{T+T}$
- Lag and delay dominated dynamics

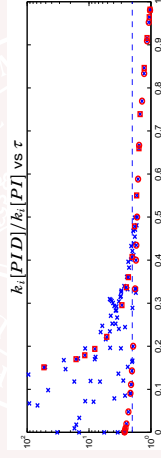

Observations

- $\tau > 0.5$ FOTD model and PI control is sufficient
- $\tau < 0.5$ Better modeling and derivative action can be significant

Relay Auto-tuning

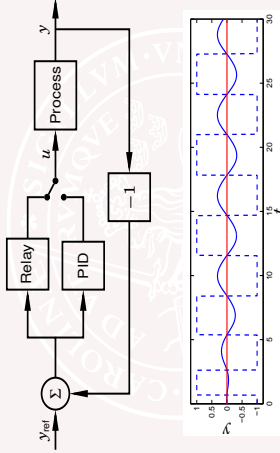

KJÅ and Tore Hägglund: Patents, Automatic tuning of simple regulators with specifications on phase and amplitude margins, Automatica 20 (5), 1984, 645-651

K. J. Åström

Travels in Process Reality

Commercial Auto-Tuners

- One-button tuning
- Automatic generation of gain schedules
- Adaptation of feedback and feedforward gains
- Many versions
 - Single loop controllers
 - DCS systems
- Robust
- Excellent industrial experience
- Large numbers



K. J. Åström

Travels in Process Reality

Temperature Control of Distillation Column

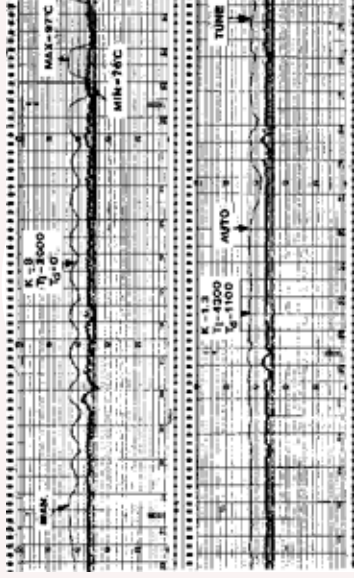

K. J. Åström

Travels in Process Reality

Industrial Systems

Functions

- Automatic tuning AT
 - Automatic generation of gain scheduling GC
 - Adaptive feedback AFB and adaptive feedforward AFF
- Sample of products
- NAF Controls SDM 20 - 1984 DCS: AT, GS, A
 - SattControl ECA 40 - 1986 SLC: AT, GS
 - Satt Control ECA 04 - 1988 SLC: AT
 - Alfa Laval Automation Alert 50 - 1988 DCS: AT, GS
 - Satt Control SattCon31 - 1988 PLC: AT, GS
 - Satt Control ECA 400 - 1988 2LC: AT, GS, A
 - Fisher Control DPR 900 - 1988 SLC: AT, GS, A
 - Satt Control SattLine - 1989 DCS: AT, GS, A
 - Fisher Control Provox - 1993 DCS: AT, GS, A
 - Emerson Delta V - 1999 DCS: AT, GS, A
 - ABB 800xA - 2004 DCS: AT, GS, A

K. J. Åström

Travels in Process Reality

Emerson Experience

- Tuner can be used by the production technicians on shift with complete control over what is going on.
- Operator is aware of the tuning process and has complete control.
- The user-friendly operator interface is consistent with other DCS applications so technicians are comfortable with it. It can be taught and become useful in less than half an hour.
- The single most important factor is that **operators and technicians take ownership of control loop performance**. This results in more loops being tuned, retuned or fine-tuned, tighter operating conditions and more consistent operations, resulting in more consistent quality and lower costs.

McMillan, Wojsznis, Meyer: Easy Tuner for DCS ISA '93

Lessons Learned

- The wide range of applications is a challenge for control research
 - Number of loops
 - Character of users
 - Resources and design efforts
 - From aerospace to process control
 - Picking relevant problems
 - Small wounds and poor friends should not be despised.
 - Fundamental limitation, time delay
 - Information needed for control design
 - FOTD model and its limitations
 - Design methods
- Load disturbance attenuation: minimize $IAE = \int_0^{\infty} |e(t)| dt$
 Robustness: limit maximum sensitivities M_p, M_r
 Measurement noise injection: bound noise gain $\|G_{wn}\|_2$
 Command response (set point weighting)
- Computations: algorithms, complexity and localization box, DCS, networks and cloud

Outline

- 1 Introduction
- 2 Computer Control
- 3 Adaptive Control
- 4 PID Control and Autotuning
- 5 Reflections

The Role of Computing

- Vannevar Bush 1927: *Engineering can proceed no faster than the mathematical analysis on which it is based. Formal mathematics is frequently inadequate for numerous problems; a mechanical solution offers the most promise.*
- Herman Goldstine 1962: *When things change by two orders of magnitude it is revolution not evolution.*
- Gordon Moore 1965: *The number of transistors per square inch on integrated circuits has doubled approximately every 18 months.*
- Moore+Goldstine: *A revolution every 10 year!*
- Productivity has not kept up with these advances because software has not kept up

What is Next?

- Next generation relay autotuners
 - Josefín Berner's thesis
 - Asymmetric relay
 - Extra excitation (chirp)?
 - System identification
 - Multivariable
- Recover the STR?
- Diagnostics (Tore)
- Oscillation detection
- Idle index
- Valve friction
- Autonomous process control
- Exploit computing & cloud
- Performance assessment
- Loop assessment
- Learning

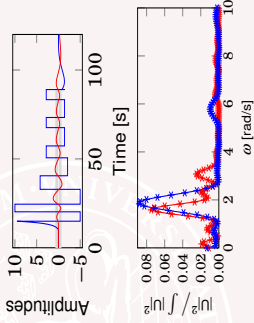
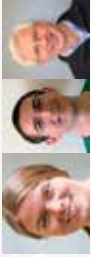

Impact of Process Reality

- Close contact with reality is a necessity for good research
- Testing and commissioning extremely valuable experiences
- Software for modeling and design
 - Computer Aided Control Engineering: IDPAC \Rightarrow Ljung; System Identification Toolbox, SYNPA, MODPAC, SIMNON, Elmquist; Dymola \Rightarrow Modelica
 - Startups: DynaSim AB (Dassault Systèmes), Modelon AB
- Software for embedded systems
 - We have taught hard real time programming since 1970 (too important to leave to computer science)
 - Classical control and analog computing
 - Computer control and embedded systems
 - Elmquist **SatLine ABB**
- **Industry should remain to be our lab!**
 - Increases credibility - a win-win situation
 - Confront teachers and students with reality
 - Exchange people between academia and industry
 - Useful to leave the comfort zone

SEBASTIAN ENGELL

TU DORTMUND

Optimal resource allocation in industrial complexes by distributed optimization and dynamic pricing

Joint work with Simon Wenzel, Radoslav Paulen, Goran Stojanovski, Stefan Krämer

We address the distributed hierarchical optimization of industrial production complexes where the individual plants exchange resources via networks. Due to the site-wide couplings a centralized or a distributed hierarchical optimization is needed to achieve the best overall performance of the site and to balance the networks of the shared resources. Because of the size of the problem, the sensitivity to missing data and especially the partial autonomy of the management of the units, a centralized solution is infeasible.



We discuss market-like algorithms that set prices of the shared resources in order to influence the individual optimizers of the units so that the overall operation converges to the site-wide optimum. Such iterative price adaptation methods are known to converge slowly if a subgradient-based price adaptation scheme is used. In order to speed up convergence, a novel algorithm for price adjustment based on the quadratic approximation of the responses of the individual optimizers is presented. It shows convergence to the site-wide optimum with significantly less iterations in comparison to the standard subgradient-based method. The price-based coordination scheme is demonstrated for a subset of the plants at a petrochemical site.

The research presented here was performed in the context of the project DYMASOS which has received funding from the European Union's Seventh Framework Programme for research, technological development and demonstration under grant agreement no 611281.

Simon Wenzel, Radoslav Paulen and Sebastian Engell are with the Process Dynamics and Operations Group at TU Dortmund, Germany. Goran Stojanovski is with the Faculty of Electrical Engineering and Information Technologies, Ss Cyril and Methodius University, Skopje, Macedonia. Stefan Krämer is with INEOS Cologne, Germany.

Optimal resource allocation in industrial complexes by distributed optimization and dynamic pricing

Simon Wenzel¹, Stefan Krämer³, Radoslav Paulen¹, Goran Stojanovski^{1,2}, Sebastian Engell¹

¹Process Dynamics and Operations Group, Department of Biochemical and Chemical Engineering

TU Dortmund

²Ss. Cyril and Methodius University in Skopje

Faculty of Electrical Engineering and Information Technologies;

³INEOS Köln GmbH



This project has received funding from the European Union's Research Framework Programme for research, technological development and demonstration under grant agreement no 611281.

Research



Process Control Methods and Applications

- ERC Advanced Grant MOBICON
- Economics optimizing control
- Robust model-based control
- Iterative optimization using gradient modifiers
- Control of polymerization processes
- Control of chromatographic separations
- Control of the miniplants in the DFG Transregio InPROMPT

Process Management

- Market-like mechanisms for the coordination of coupled units
- Real-time monitoring and optimization of resource efficiency
- Simulation environment for the distributed management of systems of systems
- Demand-side management



Control of Biotechnological Production Processes

- Modeling and control of yeast fermentations
- Modeling and model-based optimization of CHO cultures

Process Automation

- Intuitive specification of logic control programs
- Heterogeneous modelling and tool integration

Production Scheduling

- Planning and scheduling under uncertainty
- Timed automata based scheduling
- Reactive scheduling

Process Design

- Model-based support for the early stages of process development
- Algorithms for design problems with many local optima
- Batch-to-conti transfer for co-polymerizations



- about 25 PhD candidates from many countries, having degrees in (Bio-)Chemical Engineering, Computer Science, Electrical Engineering, Automation and Robotics...
- Currently 5 PostDocs: Weihua Gao, Radoslav Paulen, Maren Urselmann, Jian Cui, Elrashid Idris
- 2 part-time secretaries, 1 technician
- More than 65 finished PhD theses since 1990

EU Project DYMASOS

Dynamic Management of Physically Coupled Systems of Systems

Dealt with systems that

- Possess partial local autonomy
- Are tightly interconnected by streams of material and energy
- Examples:
 - Electric power grid
 - Chemical plants
 - Smart buildings



DYMASOS Consortium



Process Control Workshop, Lund, 28.9.2016

Management Methods

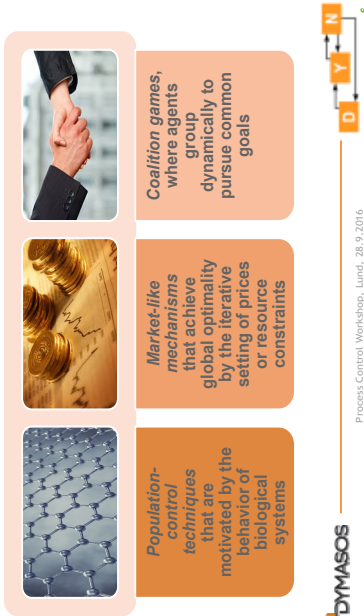

Process Control Workshop, Lund, 28.9.2016

INEOS in Köln



- Large integrated petrochemical production site
- 19 different plants
- Internal distribution networks for shared resources, e.g.,
 - Steam (30, 15, and 5 bar)
 - Electricity
 - Fuel gas
 - Intermediates
 - Products
- Cyber-physical system of systems

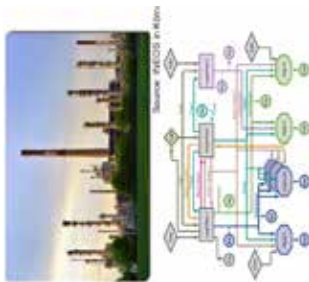

Process Control Workshop, Lund, 28.9.2016

INEOS in Köln – Site management



- The units are managed by different business units
- Individual optima and site-optimium may conflict

$$u^* \neq [u_1^*, \dots, u_n^*]$$

The goal is to reduce the total cost of operation of the site while meeting the production targets.

Goal: Site-wide optimum
plants

economic cost functions

$$\min_{u_i \in U_i, \forall i} \sum_{i=1}^n J_i(u_i)$$

$$\text{s.t. } \sum_{i=1}^n F_i(u_i) = 0$$

complicating constraint



Process Control Workshop, Lund, 28.9.2016

INEOS in Köln – Need for distributed optimization



- Centralized optimization cannot be applied: **Mathematical and technical reasons.**
 - Problem size
 - Missing information / failures
 - Scalability (adding new subsystems)
 - Confidentiality
- Confidentiality
 - Distributed solutions offer the possibility to keep certain data confidential (e.g. profit functions)
 - ⇒ Can handle competing business units or several chemical companies within a Chempark or cluster.



Process Control Workshop, Lund, 28.9.2016



9

Outline

- Distributed optimization and market-based techniques
- Case study
- Simulation results
- Conclusions and outlook



Process Control Workshop, Lund, 28.9.2016



10

MARKET-BASED TECHNIQUES FOR DISTRIBUTED OPTIMIZATION



Process Control Workshop, Lund, 28.9.2016



11

Distributed optimization problem

Resource constrained optimization problem

$$\begin{aligned} \min_{u_i \in \mathcal{U}_i, \forall i} & \sum_{i=1}^n J_i(u_i) && \text{cost reduction} \\ \text{s.t.} & \sum_{i=1}^n F_i(u_i) = 0 && \text{network constraint} \end{aligned}$$

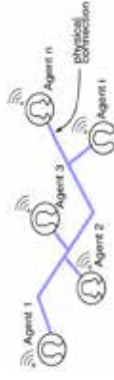

Requirements for the coordination mechanism:

- Small or no changes to the individual cost functions (leads to higher acceptance)
- Restricted communication
 - Quantity (frequency of exchanges)
 - Quality (which data) of shared information



Process Control Workshop, Lund, 28.9.2016



12

Distributed optimization problem

Resource constrained optimization problem

$$\min_{u_i \in U_i, \forall i} \sum_{i=1}^n J_i(u_i)$$

$$\text{s.t. } \sum_{i=1}^n R_i(u_i) = 0 \quad \text{network constraint}$$

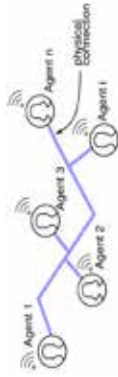

Different decomposition methods:

- Price-based coordination
- Primal decomposition
- ADMM
- Population control
- ...

- Different communication mechanisms and degrees of autonomy of the subsystems

Tatönnement process – Walrasian Auction

Excess demand: λ

Excess supply: λ

- Auctioneer (invisible hand of the market) adjusts the prices iteratively until supply and demand match
- Only resource utilization or production and prices are shared
- Objective: find the equilibrium price of the market λ^*
→ balanced networks

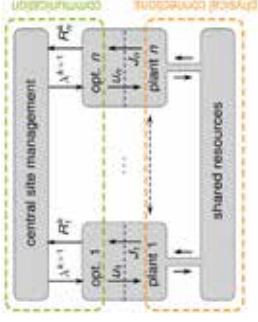

Price-based coordination

Minimization of the Lagrangian

$$\min_{u_i \in U_i, \forall i} \mathcal{L}(u_i, \lambda) = \min_{u_i \in U_i, \forall i} J(u_i) + \lambda^T \sum_{i=1}^n R_i(u_i)$$

- Lagrange multipliers λ can be interpreted as transfer prices → *Price-based coordination*
- Problem is decomposable

$$\min_{u_i \in U_i} \mathcal{L}_i(u_i, \lambda) = \min_{u_i \in U_i} J_i(u_i) + \lambda^T R_i(u_i)$$

Example: + 25 €/t · 34 y/h



Price-based coordination – Subgradient price-update

$$\lambda^{k+1} = \lambda^k + \alpha^k \sum_{i=1}^n R_i(u_i^k) \quad \text{coordinator}$$

$$u_i^{*,k+1} = \arg \min_{u_i} (J_i(u_i) + \lambda^{k+1,T} R_i(u_i)) \quad \text{plants}$$

$$R_i^{k+1} = R_i(u_i^{*,k+1})$$

Strategy converges under strict assumptions, e.g. strict convexity, sufficiently small α^k
⇒ Need for a more robust coordination strategy



Augmented Lagrangian

$$\min_{u_i \in \mathcal{U}_i, \forall i} \mathcal{L}(u_i, \lambda) = \min_{u_i \in \mathcal{U}_i, \forall i} \sum_{j=1}^n J_j(u_j) + \lambda^T \sum_{j=1}^n R_j(u_j) + \frac{\rho}{2} \left\| \sum_{j=1}^n R_j(u_j) \right\|_2^2$$

- The augmentation term convexifies the problem.
- **Direct decomposition no longer possible.**
- Alternating Direction Method of Multipliers (ADMM) is an extension that enables decomposition.



Process Control Workshop, Lund, 28.9.2016



17

ADMM – Reformulated network constraint

$$\left. \begin{aligned} \min_{u_i \in \mathcal{U}_i, \forall i} \sum_{j=1}^n J_j(u_j) & \text{ cost reduction} \\ \text{s.t. } R_j(u_j) - z_j &= \mathbf{0} \quad \forall j \\ \sum_{j=1}^n z_j &= \mathbf{0} \end{aligned} \right\} \text{ reformulated constraint}$$

Minimization of the augmented Lagrangian

$$\min_{u_i \in \mathcal{U}_i, \forall i} \mathcal{L}_\rho(u_i, z_i, \lambda) = \min_{u_i \in \mathcal{U}_i, \forall i} \sum_{j=1}^n J_j(u_j) + \lambda^T \sum_{j=1}^n R_j(u_j) + \frac{\rho}{2} \sum_{j=1}^n \| (R_j(u_j) - z_j) \|^2$$



Process Control Workshop, Lund, 28.9.2016



18

ADMM – Update steps

Additional variables z_i need to be updated by the coordinator

$$\left. \begin{aligned} \lambda^{k+1} &= \lambda^k + \frac{\rho}{n} \sum_{j=1}^n R_j(u_j)^k \\ z_j^{k+1} &= R_j(u_j)^k - \frac{1}{n} \sum_{j=1}^n R_j(u_j)^k \\ u_j^{k+1} &= \arg \min_{u_j} J_j(u_j) + \lambda^{k+1, T} R_j(u_j) + \frac{\rho}{2} \left\| (R_j(u_j) - z_j^{k+1}) \right\|_2^2 \\ R_j^{k+1} &= R_j(u_j^{k+1}) \end{aligned} \right\} \text{ coordinator, } z = \text{additional ref.} \quad \left. \right\} \text{ plants}$$



Process Control Workshop, Lund, 28.9.2016



19

Challenge: Speed of convergence

Available strategies:

- A large amount of iterations is needed
- Unrealistic if applied to semi-automated systems of systems (humans in the loop).

New price-update strategies are required that

- Preserve confidentiality.
- Have a significantly lower number of communication rounds.

DYMASOS:

- Novel price update strategy in LR by quadratic approximation of the response to speed up convergence.



Process Control Workshop, Lund, 28.9.2016



20

Promising simulation results

- It was shown that the approach outperforms the simple subgradient updates in simulation studies.
- Works well if no (few) individual constraints of the subsystems are active.

S. Wenzel et al., "Optimal resource allocation in industrial complexes by distributed optimization and dynamic pricing," at – Automatisierungstechnik, vol. 64, pp. 428–442, Jun 2016.



Process Control Workshop, Lund, 28.9.2016

21

Comparison

Price-based	Augm. Lagr.	ADMM	RQA
<ul style="list-style-type: none"> • Minimal communication • Strict assumptions • Many iterations • Difficult to tune (possible divergence) 	<ul style="list-style-type: none"> • Less assumptions • Not suited for completely distributed coordination 	<ul style="list-style-type: none"> • Robust • Difficult to tune • Communication of z variables 	<ul style="list-style-type: none"> • Minimal communication • Less iterations • No proof for convergence • Open issue of individual active constraints



Process Control Workshop, Lund, 28.9.2016

22

CASE STUDY: INEOS SITE MANAGEMENT

Topology of the case study

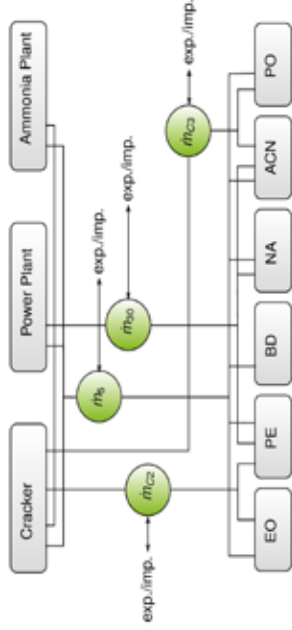

Process Control Workshop, Lund, 28.9.2016

23



Process Control Workshop, Lund, 28.9.2016

24

Mathematical modeling: generic plant

Model equations

$$x = M_{0x} \cdot u + V_x$$

$$y = M_{xy} \cdot x$$

$$R = M_{0R} \cdot u + M_{xR} \cdot x \\ = (M_{0R} + M_{xR} M_{0x}) \cdot u + M_{xR} V_x$$

- Linear (affine) functions of the manipulated variables
- The shared resources are a linear combination of states and inputs

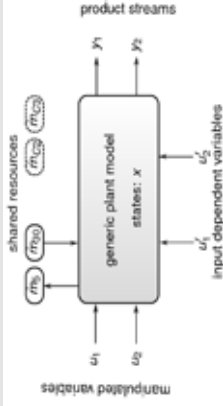

Process Control Workshop, Lund, 26.9.2016



25

The site-wide optimization problem

- The site-wide optimization problem is made up of the single plant problems
- Additionally, the complicating constraint is added

$$\min_{u_i \forall i} \sum_i J_i(u_i)$$

s. t. $u_i \in C_i \forall i \dots$ individual constraints

$$\sum_i R_i = 0 \dots \text{complicating (network) constraint}$$



Process Control Workshop, Lund, 26.9.2016



27

The individual optimization problems

Formulation of the optimization problems

$$\min_u \underbrace{p_0 u + p_x x + p_R R - p_y y + \frac{1}{2} \Delta y^T W_y \Delta y}_{\text{linear economic terms}} \underbrace{\quad}_{\text{tracking}}$$

s. t.

$$\Delta y = y - y_{ref}$$

$$lb \leq u \leq ub$$

$$A_{ineq} \cdot u \leq b_{ineq}$$

$$u \in C$$

equipment and input constraints

Model equations.



Process Control Workshop, Lund, 28.9.2016



26

SIMULATION RESULTS



Process Control Workshop, Lund, 28.9.2016



28

The DYMASOS Simulation and Validation Framework

- Designed to facilitate the simulation of SoS with distributed coordination mechanisms
- Standard interfaces for
 - The interconnection of the local and global management systems
 - The interconnection of physical models
 - The interconnection of physical models and the management systems

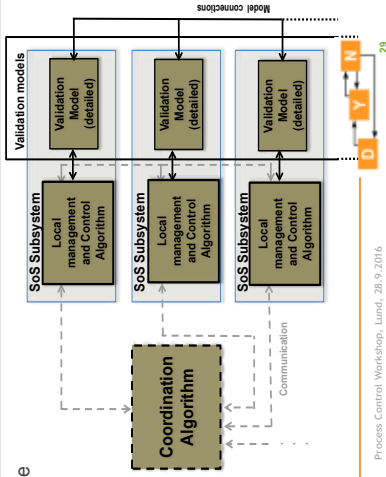

Process Control Workshop, Lund, 28.9.2016

29



Process Control Workshop, Lund, 28.9.2016

30

The DYMASOS Simulation and Validation Framework

- Modelica-based environment
- Features
 - Different communication structures
 - Different time discretization mechanisms
 - Discrete-event, discrete-time, ...
 - Co-simulation of non Modelica-based models
 - Tested environment:
 - Simulation of non external white-box and black-box controllers
 - Tested model implementations:



Implementation of the simulation study

- Modular implementation of the subsystems in Matlab®
- The simulation and validation framework (SVF) calls the models as *.dll files
- Information platform collects data from the (e.g., production references)
- The coordination is done via ADMM within the SVF

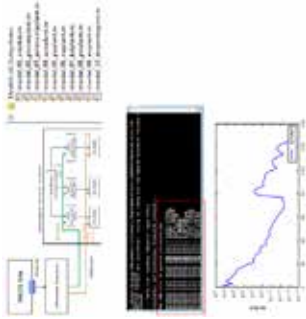

Process Control Workshop, Lund, 28.9.2016

31



Process Control Workshop, Lund, 28.9.2016

32

Setup of the simulation study

- Initial point (λ^0, u_f^0) is announced at the start of the simulation.
 - The first responses cause imbalanced networks (selfish plants).
 - ADMM is used to find a new equilibrium price vector λ^* (one operating point) for which the networks are balanced.
- Goal: **balance all networks**

$$\sum_i F_i \rightarrow \mathbf{0} = \begin{pmatrix} m_b = 0 \\ m_{b0} = 0 \\ m_{c2} = 0 \\ m_{c3} = 0 \end{pmatrix}$$



Imbalance in the networks

- Initial imbalance for λ^0 for all four networks
- Fast initial reduction of the imbalance
- Many iterations to fulfill the convergence criterion

$$\left\| \sum_{i=1}^n R_i^k \right\|_2 < \epsilon = 10^{-3}$$

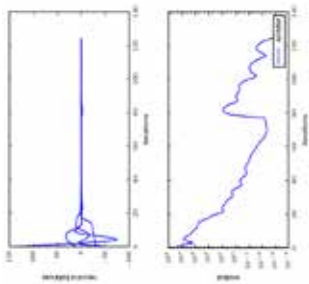

Process Control Workshop, Lund, 28.9.2016

Process Control Workshop, Lund, 28.9.2016

Adjustment of resource consumption and production (1)

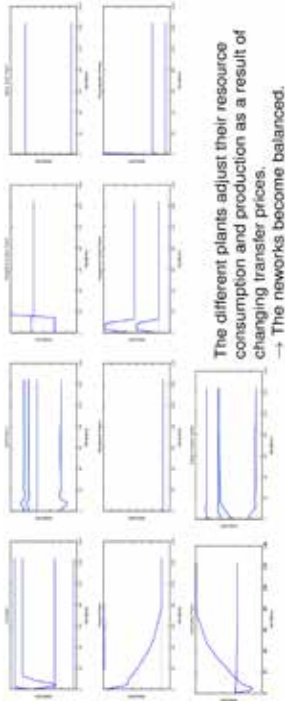

The different plants adjust their resource consumption and production as a result of changing transfer prices.
→ The networks become balanced.



34

Adjustment of resource consumption and production (2)

Ammonia Plant

- Initially reduces the consumption of one resource
- Then slow increase of one resource and slight reduction of two others
- Centralized solution is reached upon convergence

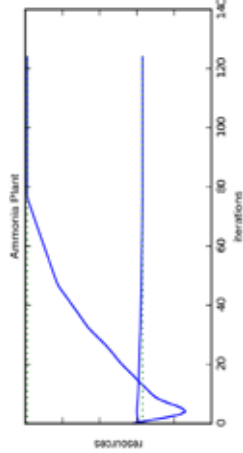

Process Control Workshop, Lund, 28.9.2016

35

Adjustment of inputs (1)

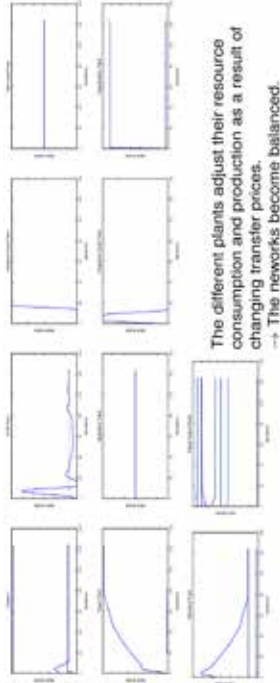

The different plants adjust their resource consumption and production as a result of changing transfer prices.
→ The networks become balanced.



Process Control Workshop, Lund, 28.9.2016

36

Changes of transfer prices

Observations

- Iterative update of the prices during the auction
- Price lowered for excess supply of resources
- Price raised for excess demand of resources
- The prices gradually settle to the equilibrium prices λ^*

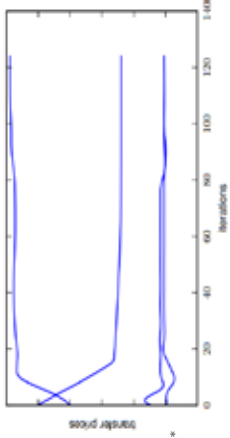

Process Control Workshop, Lund, 28.9.2016

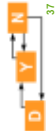

37

Reacting to the scenario

- Reoordination every hour
- After 4 and after 7 hours major changes occur
- The PE plant reduces significantly its capacity (20%)
- The C2 intake capacity of the EO plant is reduced by 50%

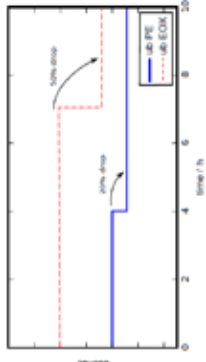

The market-based mechanism is able to balance the networks for the investigated scenario!



Process Control Workshop, Lund, 28.9.2016



38

Dynamic response

- Reoordination every hour
- After 4 and after 7 hours major changes occur
- The PE plant reduces significantly its capacity (20%)
- The C2 intake capacity of the EO plant is reduced by 50%

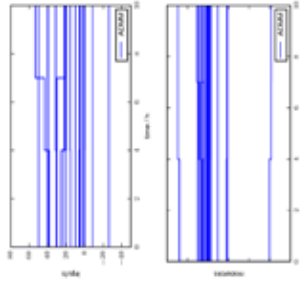

The market-based mechanism is able to balance the networks for the investigated scenario!



Process Control Workshop, Lund, 28.9.2016



39

CONCLUSIONS AND OUTLOOK



Process Control Workshop, Lund, 28.9.2016



40

Conclusions

- Realistic case study based on real data of INEOS in Köln
- Market-based coordination balances the site and reaches the site-wide optimum with a high level of confidentiality.
- Implementation and validation was done using the Modelica-based *DYMASOS Simulation and Validation Framework* (TUDO and euTexoo) with access to real plant data of INEOS in Köln via the *DYMASOS Information Platform* (RWTH Aachen).

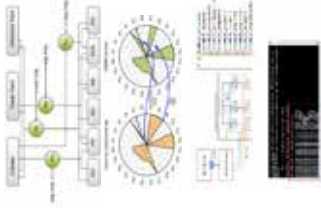

Process Control Workshop, Lund, 28.9.2016



41

Outlook

Future research

- Strong industrial interest in discrete decisions (e.g., partial shutdown of single plants).
- Improve the speed of convergence (less iterations, less communication)
- Extension of the methodology to balance resources between companies (within an industrial cluster)

New EU Project (under the last SPIRE Call):

CoPro – Improved energy and resource efficiency by better coordination of production in the process industries
(Start Nov. 2016)



Process Control Workshop, Lund, 28.9.2016



42

Selected DYMASOS publications

- S. Nazari, C. Sonntag, G. Stojanovski, and S. Engell, "A Modelling, Simulation, and Validation Framework for the Distributed Management of Large-scale Processing Systems," in Proc. PSE12ESCAPE25, (Copenhagen), pp. 269–274, 2015.
- G. Stojanovski, L. Maxeiner, S. Krämer, and S. Engell, "Real-time shared resource allocation by price coordination in an integrated petrochemical site," in Proc. 2015 Eur. Control Conf., (Linz, Austria), pp. 1488–1503, IEEE, Jul 2015.
- S. Wenzel, R. Paulen, S. Krämer, B. Beisheim, and S. Engell, "Price Adjustment in Price-based Coordination Using Quadratic Approximation," in Proc. 26th Eur. Symp. Comput. Aided Process Eng. (Z. Kravanja and M. Bogotaj, eds.), (Portoroz, Slovenia), pp. 193–198, Elsevier B.V., 2016.
- S. Wenzel, R. Paulen, S. Krämer, B. Beisheim, and S. Engell, "Shared Resource Allocation in an Integrated Petrochemical Site by Price-based Coordination Using Quadratic Approximation," in 2016 Eur. Control Conf., (Aalborg, Denmark), pp. 1045–1050, 2016.
- R. Paulen, S. Nazari, S. A. Shahidi, C. Sonntag, and S. Engell, "Primal and Dual Decomposition for Distributed MPC — Theory, Implementation, and Comparison in a SoS Simulation Framework," 2016, in Proc. 24th Mediterranean Conference on Control and Automation, pp. 286–291, 2016.
- S. Wenzel, R. Paulen, G. Stojanovski, S. Krämer, B. Beisheim, and S. Engell, "Optimal resource allocation in industrial complexes by distributed optimization and dynamic pricing," at - Automatisierungstechnik, vol. 64, no. 6, pp. 428–442, 2016.



Process Control Workshop, Lund, 28.9.2016



44

Thank you very much for your attention!



This project has received funding from the European Union's Seventh Framework Programme for research, technological development and demonstration under grant agreement No 611281.



Process Control Workshop, Lund, 28.9.2016



43

DAVE EMERSON YOKOGAWA

The Power of Context

In today's manufacturing enterprises there exists a massive amount of underutilized data stored in process historians. The data is underutilized because its context has been lost, often a result of it being maintained in a person's mind. In order for the next generation of manufacturing and information technology to provide its full promise data context must be integral to the data and be accessible and actionable by systems and algorithms.

The OPC Foundation's Unified Architecture (OPC UA) provides an open method for creating and sharing industry specific data models with the ability to exchange information using well vetted communications protocols. OPC UA has been adopted by a number of different industry groups who have and are continuing to build industry specific information models that are starting to capture the contextual information associated with data. This presentation will explain the need for context, how OPC UA information models can be used to capture context and the work required to preserve context in open, interoperable and standards based formats.



OPC Unified Architecture A Platform for Automation The Power of Context

LCCC Process Control Workshop
Lund University

Dave Emerson
Director, U.S. Technology Center
Yokogawa

LCCC Process Control Workshop
28 September 2018

Trend & Event Data Contains Little Context

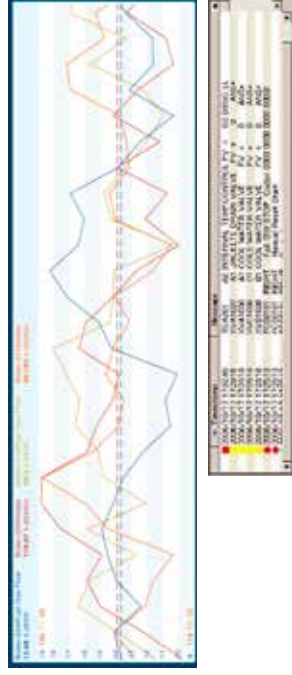

A mental model is required

LCCC Process Control Workshop
28 September 2018

3

Context

■ Context

- ◆ The circumstances that form the setting for an event, statement, or idea, and in terms of which it can be fully understood..

(oxforddictionaries.com)

■ Where is context hiding?



P&IDs Add Context

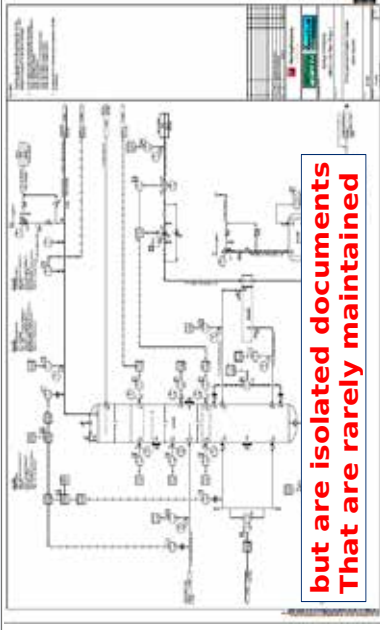

LCCC Process Control Workshop
28 September 2018

4

Operators are shown context

but must be manually designed and maintained



ICCC Process Control Workshop 28 September 2016

5

Plant Lifecycles Create & Lose Context



Each lifecycle phase creates context that is not available to downstream phases

ICCC Process Control Workshop 28 September 2016

6

Process Models contain context

but must be manually designed and maintained

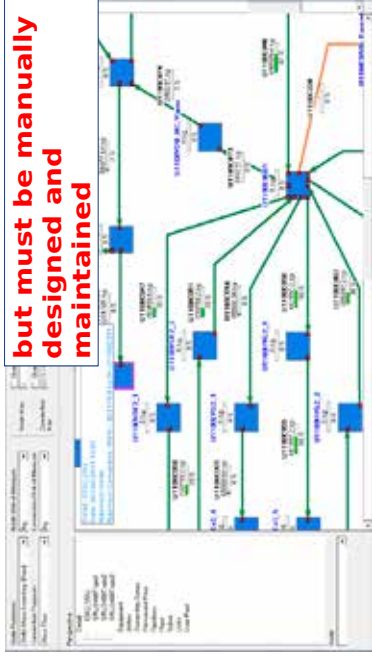

ICCC Process Control Workshop 28 September 2016

6

Silos Horde Context

Interoperability is required vertical silos must interoperate



ICCC Process Control Workshop 28 September 2016

7

Preserving Context

Federated systems discovering & sharing context

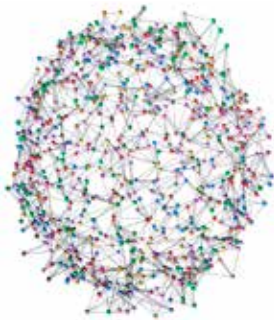

LCCC Process Control Workshop
28 September 2016
13

Preserving Context with OPC UA

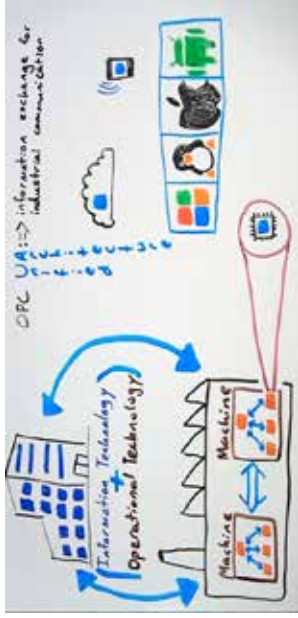

IEC 62541

What is OPC-UA? OPC-UA in a minute
<https://www.youtube.com/watch?v=TFhgIQwLkZE>

LCCC Process Control Workshop
28 September 2016
14

3 Key OPC UA Highlights

Open Data Connectivity

Connectivity
Standards



Protocols



LCCC Process Control Workshop
28 September 2016
15

3 Key UA Highlights

Data Security



- Ground-Up Secure Design
- Based on latest security standards
- Accepted by IT and OT groups
- Recognized for its security by key organizations:
 - NIST
 - Industrie 4.0
 - Oil & Gas Majors (MIDIS)

LCCC Process Control Workshop
28 September 2016
16

3 Key UA Highlights

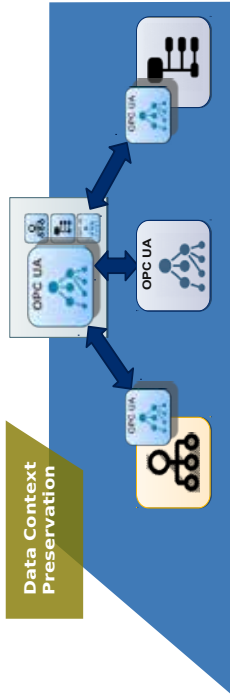

LCCG Process Control Workshop
28 September 2016
17

Services & Information Models

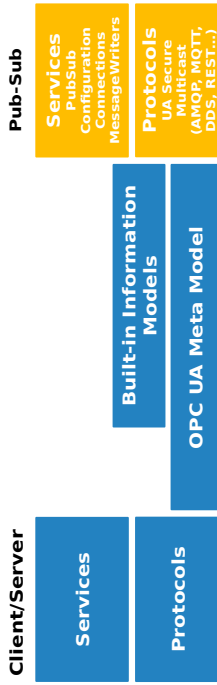

LCCG Process Control Workshop
28 September 2016
18

Services & Information Models



LCCG Process Control Workshop
28 September 2016
19

OPC Foundation Collaboration



- OPC Foundation collaborates with organizations and domain experts
- OPC UA defines HOW
- Domain experts define WHAT

LCCG Process Control Workshop
28 September 2016
20

Information Model Notation

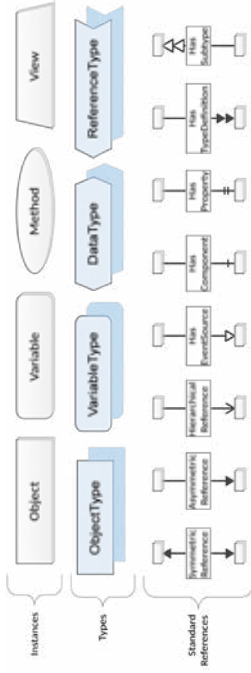

LCCP Process Control Workshop
28 September 2016
21

Sample Base Object Hierarchy

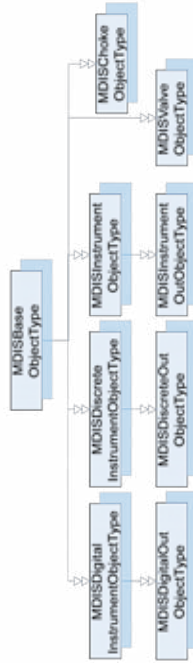

LCCP Process Control Workshop
28 September 2016
22

Information Model Example

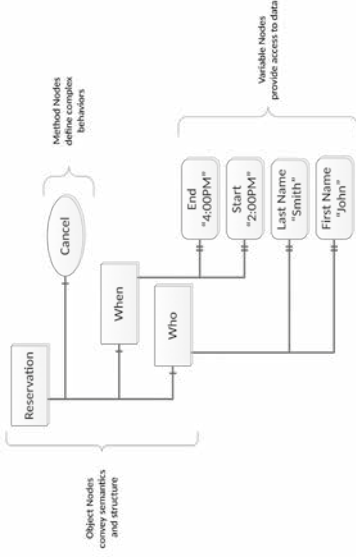

LCCP Process Control Workshop
28 September 2016
22

OPC UA for IEC 61131-3 (PLCopen)

PLCopen Collaboration

- 61131-3 Software Model mapped to OPC UA Information Model
- PLC Data provided as UA Server
- OPC UA Communication Function Blocks like Connect, Read, Call
- PLC as OPC UA Client

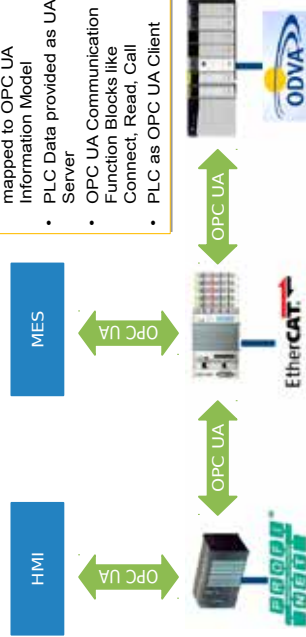

LCCP Process Control Workshop
28 September 2016
24

MDIS – Oil & Gas Industry

Industry Working Group

- Joint Team of
 - Major oil companies
 - Major DCS vendors
 - Major Subsea vendors
- Defined an industry standard information model
- Communication between silos



OPC UA for communication between Subsea Production and DCS Systems

LCCP Process Control Workshop
28 September 2016
25

UA for ISA 95 Common Object Model

Common Object Model

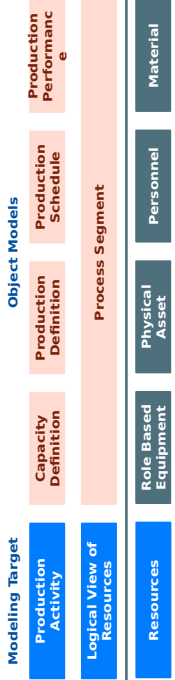

Version 1.0 Released in October 2013

ISA 95 defines a model for Enterprise/Control System integration

- OPC UA mapping for ISA 95 Resources Models
 - Role based equipment
 - Physical asset
 - Personnel
 - Material

26

MIMOSA Companion Specification

OPC UA Implementation of MIMOSA's Asset Information Model



Will bring asset management to capabilities to OPC UA compatible systems

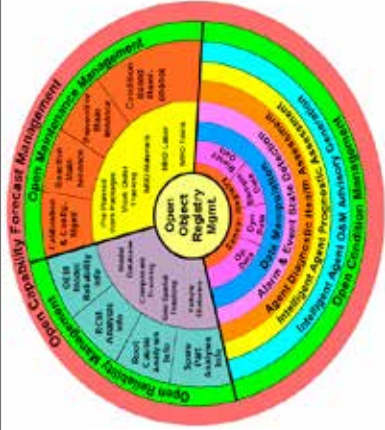

LCCP Process Control Workshop
28 September 2016
27

Preserving Context with OPC UA

Communication

- Integrated security mechanisms
- High speed UA TCP protocol
- Web services for Internet
- Platform independent
- Built-in robustness and fault tolerance
- Redundancy
- Scalable from chips to clouds

Collaboration

- UA is IEC standard 62541
- UA is base for industry & vendor information models
- Collaboration is win-win
 - Industry groups use open, proven base services
 - OPC UA users can access more domains

LCCP Process Control Workshop
28 September 2016
28

Data Modeling

- Generic object-oriented modeling
- Objects with variables, methods and events
- Extensible type system
- History for data and events
- State machines, programs, alarms & condition
- Complex data

New Applications and Use Cases

- Profiles for different use cases
- Scalability
- Integration into embedded systems
- MES and ERP systems
- Specialized versions for different industries

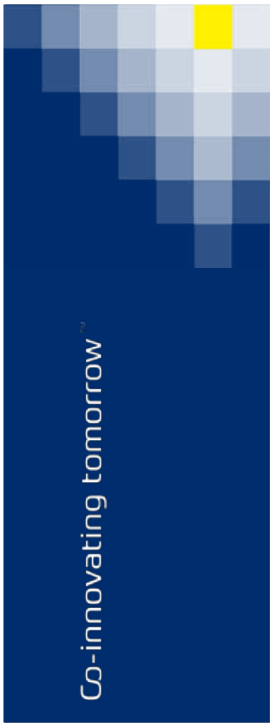

ICCF Process Facilitation Workshop
28 September 2016
29

HONGYE SU

ZHEJIANG UNIVERSITY

Research on Economic Performance Assessment and Diagnosis of Industrial MPC

Advanced Process Control (MPC) is a mature technology and has become the standard approach in industry for improving product quality, operation efficiency and enterprise profit. In this talk, I will address the recent development of economic assessment of Two-layer Industrial MPC system from two aspects, (i) An optimization approach for economic performance assessment of MPC system based on LQG benchmark and (ii) An Iterative Learning Control (ILC) approach for continuous economic performance improvement of MPC system.



Industrial MPC system typically consists of Steady State Optimization (SSO) layer and Dynamic Optimal Control (DOC) layer. By explicitly incorporating uncertainty into the performance assessment problem, economic performance evaluation can be formulated as a stochastic optimization problem by integrating SSO and DOC layers. This helps to identify the opportunity to improve profitability of the process by taking appropriate risk levels. Using the LQG benchmark to estimate achievable variability reduction through control system improvement, the proposed method provides an estimate of both the performance that can be expected from the improved control system and the operating condition that delivers the improved performance.

The above LQG based economic performance assessment requires accurate process model and computationally demanding. In order to online improve the economic performance of MPC, we further developed an ILC approach to optimize the MPC performance iteratively. With the iterative learning control (ILC) strategy, SSO problem is solved at each trial to update the tuning parameter and designed condition of DOC, then DOC is conducted in the condition guided by SSO. The ILC strategy is proposed to adjust the tuning parameter of DOC based on the sensitivity analysis. The convergence

of EPD by the proposed ILC has also been proved. The performance of the proposed method is illustrated via an SISO numerical system as well as an MIMO industry process.



Research on Economic Performance Assessment and Diagnosis of Industrial MPC

Hongye Su

National Key Laboratory of Industrial Control Technology
Institute of Cyber-Systems and Control
Zhejiang University, China

Outline

1. Why CPA
2. CPA of PID Loop
3. Economic PA of Industrial MPC
4. On-line EPI of Industrial MPC
5. MPM Detection of MPC with Mutual Information

MPC: Model **P**redictive **C**ontrol

3

Petrochemical Industry

1. **Pillar industry in the world**
 - The first major pillar industry in the world
 - **\$14.9 trillion** gross output in the world (2013)
 - China as number one
2. **Big energy producer, Big energy user**
 - 15% of total energy consumption
 - 15%~20% **above the average energy consumption level**



MPC: Enabling Technology of Saving Energy and Increasing Profit

2

Control System: Big Investment

1. **Typical Control Loop Investment: \$25,000 (ABB Company)**
 - Hardware: Including valve, sensor, controller etc.
 - Software: Control algorithm, SCADA system etc.
2. **Typical Petrochemical Process: 10²~10³ Loops**

Improperly Working Control System



4

However:

1. Fewer and fewer adequately educated control engineer
2. Average control engineer responsible > 100 loops

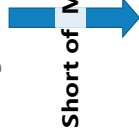

Control Performance Reality: **Not Good**

5

Outline

1. Why CPA
2. CPA of PID Loop
3. Economic PA of Industrial MPC
4. On-line Economic Performance Improvement of Industrial MPC
5. Model-Plant Mismatch Detection of MPC using Mutual Information

MPC: Model Predictive Control

6

PID Loop: Basis of MPC

PID: Execute MPC command



Baowei Fu, Lei Xie, Zhihuan Song, Yong Cheng, PID control performance assessment using iterative convex Programming, Journal of Process Control, 2012, 22: 1139-1159.

7

PID Regulatory Performance

Measured by Loop Output Variance

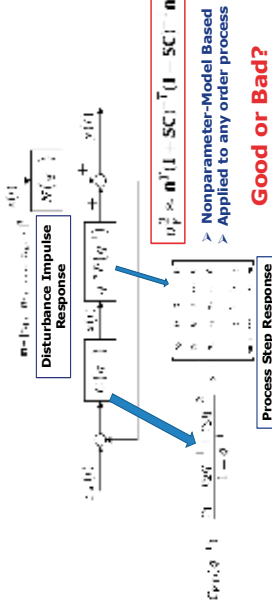

CPA of PID

Good or Bad?

Find the benchmark:
Minimum Output Variance

$$\min_{\mathbf{C}} \mathbf{n}^T (\mathbf{I} - \mathbf{S}\mathbf{C})^{-1} (\mathbf{I} + \mathbf{S}\mathbf{C})^{-1} \mathbf{n}$$

Nonconvex!

9

CPA of PID

Good or Bad?

$$\min_{\mathbf{C}} \mathbf{n}^T (\mathbf{I} - \mathbf{S}\mathbf{C})^{-1} (\mathbf{I} + \mathbf{S}\mathbf{C})^{-1} \mathbf{n}$$

Nonconvex!

Schur Complement

$$\min_{\mathbf{C}} \begin{bmatrix} \mathbf{n}^T & \mathbf{0} \\ \mathbf{0} & \mathbf{I} \end{bmatrix} \begin{bmatrix} \mathbf{I} + \mathbf{S}\mathbf{C} & \mathbf{0} \\ \mathbf{0} & \mathbf{I} - \mathbf{S}\mathbf{C} \end{bmatrix} \begin{bmatrix} \mathbf{n} \\ \mathbf{0} \end{bmatrix}$$

Nonconvex Constraints 10

CPA of PID

Good or Bad?

Lagrange method & Fixed-point Alg.

$$\min_{\mathbf{C}} \mathbf{n}^T (\mathbf{I} - \mathbf{S}\mathbf{C})^{-1} (\mathbf{I} + \mathbf{S}\mathbf{C})^{-1} \mathbf{n}$$

Nonconvex!

Schur Complement

$$\min_{\mathbf{C}} \begin{bmatrix} \mathbf{n}^T & \mathbf{0} \\ \mathbf{0} & \mathbf{I} \end{bmatrix} \begin{bmatrix} \mathbf{I} + \mathbf{S}\mathbf{C} & \mathbf{0} \\ \mathbf{0} & \mathbf{I} - \mathbf{S}\mathbf{C} \end{bmatrix} \begin{bmatrix} \mathbf{n} \\ \mathbf{0} \end{bmatrix}$$

Nonconvex Constraints 11

CPA of PID

Good or Bad?

$$\min_{\mathbf{C}} \mathbf{n}^T (\mathbf{I} - \mathbf{S}\mathbf{C})^{-1} (\mathbf{I} + \mathbf{S}\mathbf{C})^{-1} \mathbf{n}$$

Nonconvex!

Schur Complement

$$\min_{\mathbf{C}} \begin{bmatrix} \mathbf{n}^T & \mathbf{0} \\ \mathbf{0} & \mathbf{I} \end{bmatrix} \begin{bmatrix} \mathbf{I} + \mathbf{S}\mathbf{C} & \mathbf{0} \\ \mathbf{0} & \mathbf{I} - \mathbf{S}\mathbf{C} \end{bmatrix} \begin{bmatrix} \mathbf{n} \\ \mathbf{0} \end{bmatrix}$$

Lagrange method & Fixed-point Alg.

$$\min_{\mathbf{C}} \begin{bmatrix} \mathbf{n}^T & \mathbf{0} \\ \mathbf{0} & \mathbf{I} \end{bmatrix} \begin{bmatrix} \mathbf{I} + \mathbf{S}\mathbf{C} & \mathbf{0} \\ \mathbf{0} & \mathbf{I} - \mathbf{S}\mathbf{C} \end{bmatrix} \begin{bmatrix} \mathbf{n} \\ \mathbf{0} \end{bmatrix}$$

Nonconvex Constraints 12

CPA of PID

Good or Bad?



Successive Convex Problem

$$v^* = \arg \min_{v \in \mathcal{V}} \text{trace}(M(v)) - \gamma \text{trace}(N(v))$$

Lagrange method & Fixed-point Alg.



Schur Complement

$$\min_C n^T (T - SC)^{-1} (T + SC)^{-1} n$$

Nonconvex!

$$v^* = \arg \min_{v \in \mathcal{V}} \text{trace}(M(v)) - \gamma \text{trace}(N(v))$$

Nonconvex Constraints

CPA of PID

Successive Convex Problem

$$v^* = \arg \min_{v \in \mathcal{V}} \text{trace}(M(v)) - \gamma \text{trace}(N(v))$$

Readily Solved!

CPA: Compare current loop output variance with the benchmark

Algorithm 1. The proposed iterative convex programming approach.
 Step 1: Solve the convex problem (11) to obtain the solution v^* .
 Step 2: Compute the matrix inverse $(T - SC)^{-1}$ with the obtained PID parameters.
 Step 3: Compute the matrix inverse $(T + SC)^{-1}$ with the obtained PID parameters.
 Iterate $(v^*)^k \leftarrow (v^*)^{k-1}$ for $k = 1, 2, \dots$.

CPA of PID

Test on 100 typical single-loop

Case	Method	OF Objective Value	Time (s)
1	CPA	0.0000	0.0000
2	CPA	0.0000	0.0000
3	CPA	0.0000	0.0000
4	CPA	0.0000	0.0000
5	CPA	0.0000	0.0000
6	CPA	0.0000	0.0000
7	CPA	0.0000	0.0000
8	CPA	0.0000	0.0000
9	CPA	0.0000	0.0000
10	CPA	0.0000	0.0000
11	CPA	0.0000	0.0000
12	CPA	0.0000	0.0000
13	CPA	0.0000	0.0000
14	CPA	0.0000	0.0000
15	CPA	0.0000	0.0000
16	CPA	0.0000	0.0000
17	CPA	0.0000	0.0000
18	CPA	0.0000	0.0000
19	CPA	0.0000	0.0000
20	CPA	0.0000	0.0000
21	CPA	0.0000	0.0000
22	CPA	0.0000	0.0000
23	CPA	0.0000	0.0000
24	CPA	0.0000	0.0000
25	CPA	0.0000	0.0000
26	CPA	0.0000	0.0000
27	CPA	0.0000	0.0000
28	CPA	0.0000	0.0000
29	CPA	0.0000	0.0000
30	CPA	0.0000	0.0000
31	CPA	0.0000	0.0000
32	CPA	0.0000	0.0000
33	CPA	0.0000	0.0000
34	CPA	0.0000	0.0000
35	CPA	0.0000	0.0000
36	CPA	0.0000	0.0000
37	CPA	0.0000	0.0000
38	CPA	0.0000	0.0000
39	CPA	0.0000	0.0000
40	CPA	0.0000	0.0000
41	CPA	0.0000	0.0000
42	CPA	0.0000	0.0000
43	CPA	0.0000	0.0000
44	CPA	0.0000	0.0000
45	CPA	0.0000	0.0000
46	CPA	0.0000	0.0000
47	CPA	0.0000	0.0000
48	CPA	0.0000	0.0000
49	CPA	0.0000	0.0000
50	CPA	0.0000	0.0000
51	CPA	0.0000	0.0000
52	CPA	0.0000	0.0000
53	CPA	0.0000	0.0000
54	CPA	0.0000	0.0000
55	CPA	0.0000	0.0000
56	CPA	0.0000	0.0000
57	CPA	0.0000	0.0000
58	CPA	0.0000	0.0000
59	CPA	0.0000	0.0000
60	CPA	0.0000	0.0000
61	CPA	0.0000	0.0000
62	CPA	0.0000	0.0000
63	CPA	0.0000	0.0000
64	CPA	0.0000	0.0000
65	CPA	0.0000	0.0000
66	CPA	0.0000	0.0000
67	CPA	0.0000	0.0000
68	CPA	0.0000	0.0000
69	CPA	0.0000	0.0000
70	CPA	0.0000	0.0000
71	CPA	0.0000	0.0000
72	CPA	0.0000	0.0000
73	CPA	0.0000	0.0000
74	CPA	0.0000	0.0000
75	CPA	0.0000	0.0000
76	CPA	0.0000	0.0000
77	CPA	0.0000	0.0000
78	CPA	0.0000	0.0000
79	CPA	0.0000	0.0000
80	CPA	0.0000	0.0000
81	CPA	0.0000	0.0000
82	CPA	0.0000	0.0000
83	CPA	0.0000	0.0000
84	CPA	0.0000	0.0000
85	CPA	0.0000	0.0000
86	CPA	0.0000	0.0000
87	CPA	0.0000	0.0000
88	CPA	0.0000	0.0000
89	CPA	0.0000	0.0000
90	CPA	0.0000	0.0000
91	CPA	0.0000	0.0000
92	CPA	0.0000	0.0000
93	CPA	0.0000	0.0000
94	CPA	0.0000	0.0000
95	CPA	0.0000	0.0000
96	CPA	0.0000	0.0000
97	CPA	0.0000	0.0000
98	CPA	0.0000	0.0000
99	CPA	0.0000	0.0000
100	CPA	0.0000	0.0000

Can obtain the benchmark accurately & quickly

Outline

1. Why CPA
2. CPA of PID Loop
3. Economic PA of Industrial MPC
4. On-line Economic Performance Improvement of Industrial MPC
5. Model-Plant Mismatch Detection of MPC using Mutual Information

MPC: Model Predictive Control

MPC Performance Assessment (PA)

More Important & Challenging!

1. Widely applied petrochemical industry
 - > 50 new projects/year in China
 - > 400 in service in China
2. Control objective of MPC is highly related to economic profit of plant
3. Performance may degrade quickly
 - Typical 6 months good-performance-period after commissioning

17

Industrial MPC

Double-Layer Structure of Industrial MPC

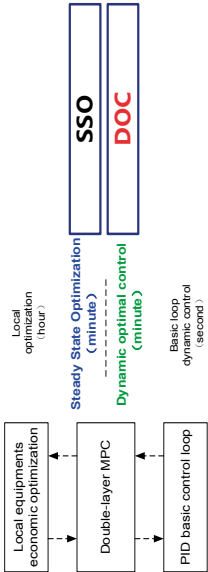

Zhao, C., V. Zhao, H. Su and B. Huang (2009), "Economic performance assessment of advanced process control with LQG benchmarking", *Journal of Process Control* 19(4): 557-569.
 Liu, Z., Y. Gu and L. Xie (2012), "An improved LQG benchmark for MPC economic performance assessment and optimization in process industry", *Canadian Journal of Chemical Engineering* 90(6): 1434-1441.

18

DOC PA based on LQG

Given $E\{u^2\} \leq \alpha$, what is minimum of $E\{y^2\}$?

Varying λ Solving the LQG problem

Obtain the MPC Performance Limit Curve

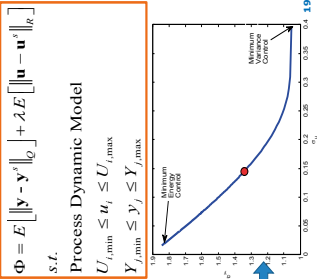

19

Economic PA of Double-Layer Industrial MPC

Double-Layer Structure of Industrial MPC

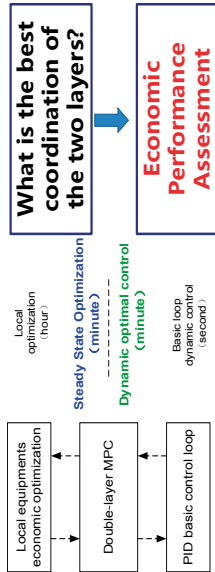

What is the best coordination of the two layers?

Economic Performance Assessment

Zhao, C., V. Zhao, H. Su and B. Huang (2009), "Economic performance assessment of advanced process control with LQG benchmarking", *Journal of Process Control* 19(4): 557-569.
 Liu, Z., Y. Gu and L. Xie (2012), "An improved LQG benchmark for MPC economic performance assessment and optimization in process industry", *Canadian Journal of Chemical Engineering* 90(6): 1434-1441.

20

Economic PA of Double-Layer Industrial MPC

$$\max_{y^j, \sigma_y, \sigma_u} \Delta J = \sum_{j=1}^m C_j^T (y^j)^* - \sum_{i=1}^m C_i^T u_i^i$$

$$s.t. \Delta J = \sum_{j=1}^m C_j^T (y^j)^* - \sum_{i=1}^m C_i^T u_i^i$$

Process Dynamic Model

$$U_{j, \min} \leq u_j \leq U_{j, \max}$$

$$Y_{j, \min} \leq y_j \leq Y_{j, \max}$$

$$\Delta u_i^i = u_i^i - u_i^{i,0}$$

$$\Delta y_j^j = y_j^j - y_j^{j,0}$$

$$Y_{j, \min} + z_{j,0} \sigma_y \leq y_j^j \leq Y_{j, \max} - z_{j,0} \sigma_y$$

$$U_{j, \min} + z_{j,0} \sigma_u \leq u_j \leq U_{j, \max} - z_{j,0} \sigma_u$$

$$\sigma_y \geq 0$$

$$\sigma_u \geq 0$$

$$\sigma_y = f(\sigma_u)$$

I/O Variances determined in DOC

Steady State Optimization (SSO)

Dynamic Optimal Control (DOC)

21

Economic PA of Double-Layer Industrial MPC

$$\max_{y^j, \sigma_y, \sigma_u} \Delta J = \sum_{j=1}^m C_j^T (y^j)^* - \sum_{i=1}^m C_i^T u_i^i$$

$$s.t. \Delta J = \sum_{j=1}^m C_j^T (y^j)^* - \sum_{i=1}^m C_i^T u_i^i$$

$$\Delta u_i^i = u_i^i - u_i^{i,0}$$

$$\Delta y_j^j = y_j^j - y_j^{j,0}$$

$$Y_{j, \min} + z_{j,0} \sigma_y \leq y_j^j \leq Y_{j, \max} - z_{j,0} \sigma_y$$

$$U_{j, \min} + z_{j,0} \sigma_u \leq u_j \leq U_{j, \max} - z_{j,0} \sigma_u$$

$$\sigma_y \geq 0$$

$$\sigma_u \geq 0$$

$$\sigma_y = f(\sigma_u)$$

Best I/O Variances Coordination based on LQG Benchmark

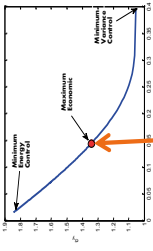

SSO

DOC

22

Economic PA of Double-Layer Industrial MPC

$$\max_{y^j, \sigma_y, \sigma_u} \Delta J = \sum_{j=1}^m C_j^T (y^j)^* - \sum_{i=1}^m C_i^T u_i^i$$

$$s.t. \Delta J = \sum_{j=1}^m C_j^T (y^j)^* - \sum_{i=1}^m C_i^T u_i^i$$

$$\Delta u_i^i = u_i^i - u_i^{i,0}$$

$$\Delta y_j^j = y_j^j - y_j^{j,0}$$

$$Y_{j, \min} + z_{j,0} \sigma_y \leq y_j^j \leq Y_{j, \max} - z_{j,0} \sigma_y$$

$$U_{j, \min} + z_{j,0} \sigma_u \leq u_j \leq U_{j, \max} - z_{j,0} \sigma_u$$

$$\sigma_y \geq 0$$

$$\sigma_u \geq 0$$

$$\sigma_y = f(\sigma_u)$$

Steady State Optimization (SSO)

Dynamic Optimal Control (DOC)

21

Economic PA of Double-Layer Industrial MPC

Economic Assessment Indexes

$$\eta_E = \frac{\Delta J_E}{\Delta J_I} \leq 1$$

ΔJ_E : Obtained economic performance
 ΔJ_I : Ideal economic performance

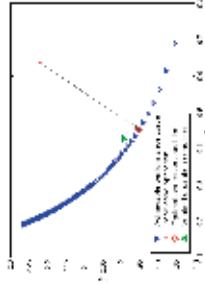

23

Economic PA of Double-Layer Industrial MPC

Application on Delayed Coking Furnace Control :

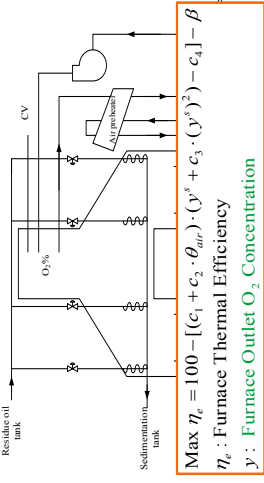

$$\text{Max } \eta_E = 100 - [(c_1 + c_2 \cdot \theta_{air}) \cdot (y^s + c_3 \cdot (y^s)^2) - c_4] - \beta$$

η_E : Furnace Thermal Efficiency
 y : Furnace Outlet O₂ Concentration

24

Economic PA of Double-Layer Industrial MPC

Delayed Coking Furnace Control

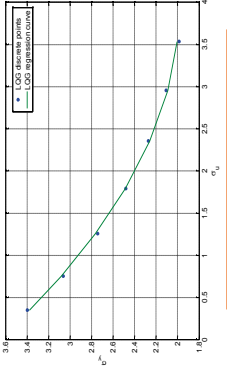

LQG Benchmark Curve

25

Economic PA of Double-Layer Industrial MPC

Delayed Coking Furnace Control

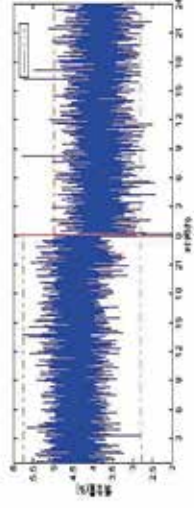

Furnace Output O_2 : 4.6% \rightarrow 3.5%
Thermal Efficiency: 86.5% \rightarrow 87.1%

26

Outline

1. Why CPA
2. CPA of PID Loop
3. Economic PA of Industrial MPC
4. On-line Economic Performance Improvement of Industrial MPC
5. Model-Plant Mismatch Detection of MPC using Mutual Information

MPC: Model Predictive Control

27

On-line Performance Improvement of Double-Layer Industrial MPC

1. Requires an accurate process model
2. Computationally demanding



Off-line Performance Assessment

LQG Benchmark

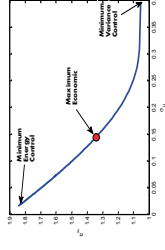

X. Cai, P. Sun, J. Chen, L. Xie, ILQ strategy for progress improvement of economic performance in industrial model predictive control systems, Journal of Process Control, 24 (2014) 107-118.

28

On-line Performance Improvement of Double-Layer Industrial MPC

- Iterative Learning Control (ILC)
- Data-Driven
- Model-Free



On-line Economic Performance Improvement (EPI)

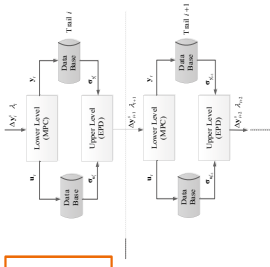

X. Cai, P. Sun, J. Chen, L. Xie, ILC strategy for progress improvement of economic performance in industrial model predictive control systems, *Journal of Process Control*, 24 (2014) 107-118.

29

On-line Performance Improvement of Double-Layer Industrial MPC

$$\max_{y^s, \sigma_y, \sigma_u} J = \sum_{j=1}^n C_j^T y_j^s - \sum_{i=1}^m C_i^T u_i^s$$

$$s.t. \square y_j^s = \sum_{i=1}^m k_{ij} \square u_i^s$$

$$\Delta u_i^s = u_i^s - u_i^0$$

Find Active Constraints

$$J_{j,\min} + z_{j,0} \sigma_y \leq y_j^s \leq J_{j,\max} - z_{j,0} \sigma_y$$

$$U_{i,\min} + z_{i,0} \sigma_u \leq u_i^s \leq U_{i,\max} - z_{i,0} \sigma_u$$

$$\sigma_y \geq 0$$

$$\sigma_u \geq 0$$

$$\sigma_y = f(\sigma_u)$$

SSO

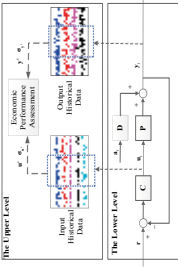

I/O variance from the operation data

30

On-line Performance Improvement of Double-Layer Industrial MPC

$$\max_{y^s, \sigma_y, \sigma_u} J = \sum_{j=1}^n C_j^T y_j^s - \sum_{i=1}^m C_i^T u_i^s$$

$$s.t. \square y_j^s = \sum_{i=1}^m k_{ij} \square u_i^s$$

$$\Delta u_i^s = u_i^s - u_i^0$$

Find Active Constraints

$$J_{j,\min} + z_{j,0} \sigma_y \leq y_j^s \leq J_{j,\max} - z_{j,0} \sigma_y$$

$$U_{i,\min} + z_{i,0} \sigma_u \leq u_i^s \leq U_{i,\max} - z_{i,0} \sigma_u$$

$$\sigma_y \geq 0$$

$$\sigma_u \geq 0$$

$$\sigma_y = f(\sigma_u)$$

SSO

Sensitivity Analysis

ILC-based DOC Weights Retuning

$$\Phi = E \left[\left\| \begin{bmatrix} y - y^s \\ u - u^s \end{bmatrix} \right\|_R \right] + \lambda \hat{\lambda} \left\| \begin{bmatrix} u - u^s \\ R \end{bmatrix} \right\|_R$$

s.t.

Process Dynamic Model

$$U_{i,\min} \leq u_i \leq U_{i,\max}$$

$$Y_{j,\min} \leq y_j \leq Y_{j,\max}$$

DOC

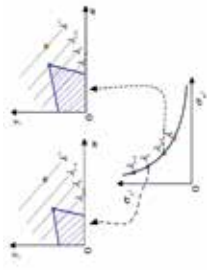

Active Constraints Relaxed

$$\sigma_y \geq 0$$

$$\sigma_u \geq 0$$

$$\sigma_y = f(\sigma_u)$$

SSO

I/O Variances Re-distributed

32

On-line Performance Improvement of Double-Layer Industrial MPC

Improved Economic Performance

$$S(x, y) = \sum_{i=1}^n \lambda_i y_i - u_i$$

$$\Delta u_i^s = u_i^s - u_i^{s0}$$

$$\Delta y_i^s = y_i^s - y_i^{s0}$$

Active Constraints Relaxed

$$\sigma_y \leq 0$$

$$\sigma_u \geq 0$$

$$\sigma_y = f(\sigma_u)$$

SSO

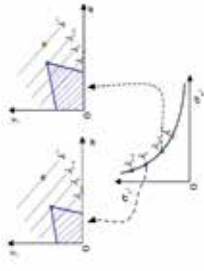

I/O Variances Re-distributed

33

MPC: Model Predictive Control

34

Outline

1. Why CPA
2. CPA of PID Loop
3. Economic PA of Industrial MPC
4. On-line Economic Performance Improvement of Industrial MPC
5. **Model-Plant Mismatch Detection of MPC using Mutual Information**

MPM Detection for MPC Using MI

1. Model is the core of MPC

□ MPC heavily relies on an accurate model to predict the process behavior

2. **Model Plant Mismatch (MPM)** is the No.1 root cause of poor MPC control performance

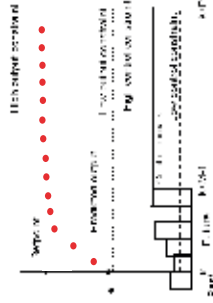

G. Chen, L. Xie, J. Zeng, J. Chu, Y. Gu, Detecting Model-Plant Mismatch of Nonlinear Multivariable Systems Using Mutual Information, Ind Eng Chem Res, 52 (2013) 1927-1938.

35

Mutual Information: $I(X; Y)$

Given two random variables X, Y

$$I(X; Y) = H(X) + H(Y) - H(X, Y)$$

$$H(X) = - \int p(x) \ln(p(x)) dx$$

$$H(Y) = - \int p(y) \ln(p(y)) dy$$

$$H(X, Y) = - \int p(x, y) \ln(p(x, y)) dx dy$$

MI quantify the information shared by X and Y

$I(X; Y) = 0$ iff X and Y are independent

MPM detection using MI

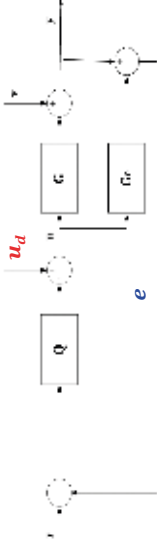

No MPM: $e = v$ independent of u_d
 $I(e; u_d) = 0$
MPM: $I(e; u_d) \neq 0$

37

MI Estimation

- MI Estimation
- K-nearest neighbor approach

$$\hat{f}(X; Y) = \psi(k) - \frac{1}{k} - \frac{1}{N} \sum_{l=1}^N [\psi(u_l(t)) + \psi(u_l(t))] + \psi(N)$$

- MI Statistic Confidence Limit

- Surrogate data approach**
- IAAFT: iterative amplitude adjusted Fourier Transform

Industrial Application: Polypropylene Process

Polypropylene: General Purpose Plastic



Double-loop liquid propylene polymerization plant of SINOPEC Co. Ltd. (Zhengshan)

40

MPM Localization using MI

MIMO System

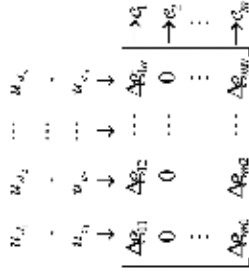

If $I(e_j; u_d) \neq 0$, then the j th column of $\Delta G(:, j) \neq 0$,

39

MPC for R201, R202

Table 1. MVs and CVs of the MPC for Tubular Reactors

variable	description
MVs	
MV1	flow of hydrogen
MV2	flow of propylene monomer
CVs	
CV1	concentration of hydrogen
CV2	density of slurry

41

MPC Performance

Slurry density: Important quality Index

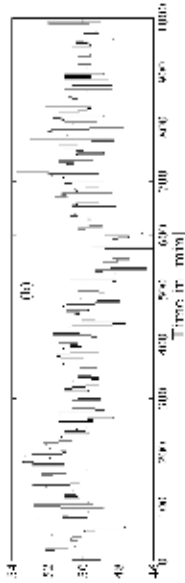

Control results of MPC after commissioning for 7 months

43

MPC Performance

Slurry density: Important quality Index

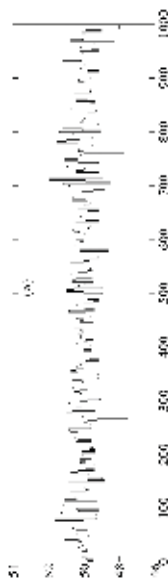

Control results of MPC at early commissioning stage

42

MPM Detection of R201

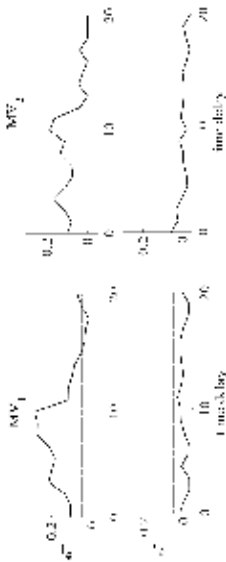

MPM exist in the channels of

$MV_1 \rightarrow e_1$ and $MV_2 \rightarrow e_1$

44

MPC Performance after Maintenance

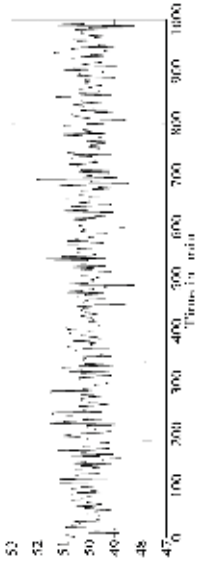

Control results of MPC after model re-identification

45

Thank You!

46

JUNQIANG (JAMES) FAN

UTC CLIMATE, CONTROLS & SECURITY

Control design and verification with physics based models for HVAC/R applications

A model-based control design and verification process is applied for heating, ventilation, air-conditioning and Refrigeration (HVAC/R) systems. The process covers each stage from requirements, to dynamic modeling, to control design and verification, and finally to product launch. Physics-based dynamic modeling is a key step to enable robust control design and performance evaluation. This process has been demonstrated in many new United Technologies' product developments with significant control performance improvement. 3 typical HVAC/R examples (a transportation refrigeration system, a supermarket refrigeration system, and a residential HVAC system) will be presented to illustrate the effectiveness of this model based design process.





United Technologies

Climate | Controls | Security

Control Design and Verification with Physics Based Models for HVAC/R Applications

Junqiang (James) Fan
Fellow, Systems and Controls Engineering
Sept 28, 2016

OUTLINE

- Vapor compression refrigeration cycle
- Model Based Control Development Process
- Application Examples
 - Transportation Refrigeration
 - Commercial Refrigeration
 - Residential HVAC
 - Commercial Building HVAC
- Conclusions

VAPOR COMPRESSION REFRIGERATION CYCLE

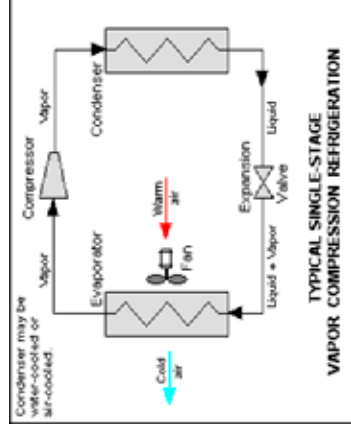

3

2

WHAT IS CONTROL OF HVAC/R?

Reliably operating HVAC/R systems to be functional and energy efficient

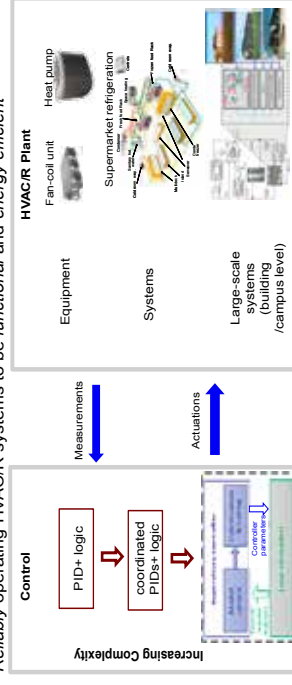

What's important?

- Control architecture & algorithm design
- Implementation and test/verification
- Tuning and commissioning
- Operation & upgrading

What's important?

- Know the physics, systems objectives and limitations
- Model the physics, component to system
- System complexity

4

MODEL BASED CONTROL DEVELOPMENT PROCESS

From requirements definition to field support

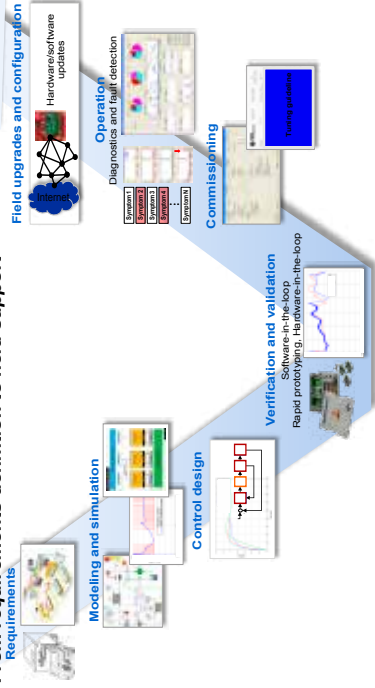

APPLICATION EXAMPLES

Equipment

Pulsor™ - Truck Refrigeration Equipment
Developed control architecture and algorithm for robust system performance and optimal efficiency

Systems

CO₂OLTEC™ - Supermarket Refrigeration System
Developed control commissioning guidelines in use by Carrier installers

Infinity NG™ - Residential HVAC System
Demonstrated HW-independent, model based developed control algorithm on scalable SW platform

Large Systems/Buildings
Supervisory control algorithm : 10% to 15% energy consumption reduction.

PULSOR™ ... TRUCK REFRIGERATION

Architecture and algorithm design

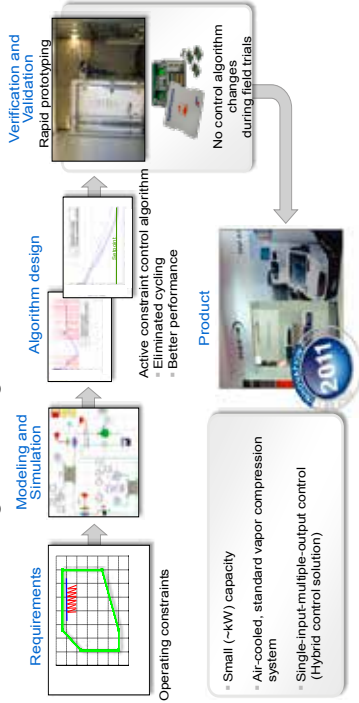

CO₂OLTEC™ ... SUPERMARKET REFRIGERATION

Faster and accurate system commissioning

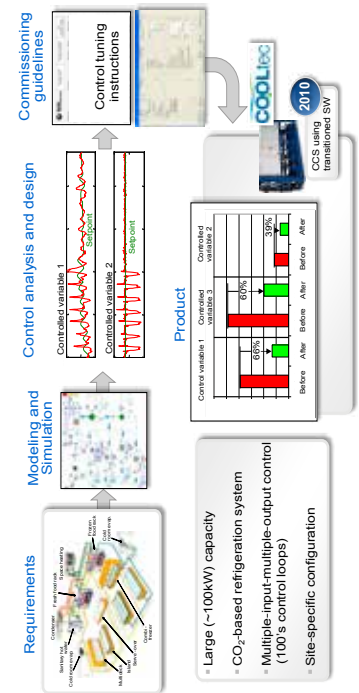

CO₂OLtec™: Gas Cooler Modeling

More physics captured by 2-D cross-flow HX model versus 1-D counter flow HX model at reasonable cost of simulation speed

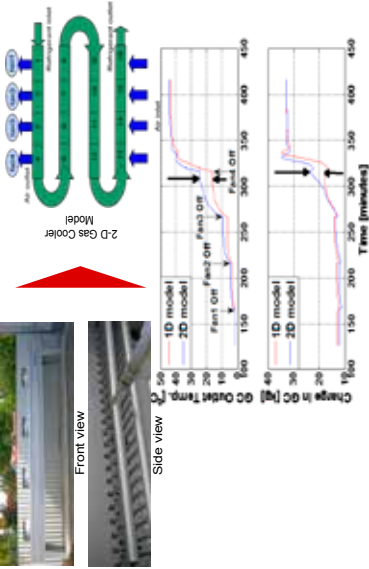

INFINITY NG .. RESIDENTIAL HVAC Software architecture and system control design

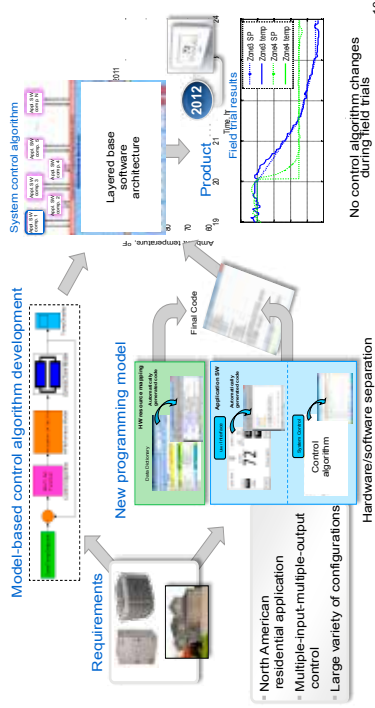

10

INTEGRATED WHOLE-BUILDING HVAC MODEL

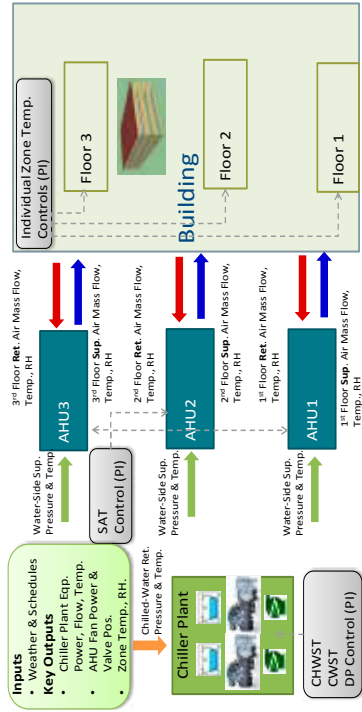

11

SUMMARY OF CASE STUDIES

4 Case Configurations

Case Configuration	Definition
1	Medium Office + Primary Only Other Plant Configuration
2	Medium Office + Primary + Secondary Other Plant Configuration
3	Large Hotel + Primary Only Other Plant Configuration
4	Large Hotel + Primary + Secondary Other Plant Configuration

8 Test Profiles (each case config.)

Test Case	Test Case Scenario
Test 1	Miami Summer
Test 2	Miami Shoulder
Test 3	Las Vegas Summer
Test 4	Las Vegas Shoulder
Test 5	Baltimore Summer
Test 6	Baltimore Shoulder
Test 7	Chicago Summer
Test 8	Chicago Shoulder

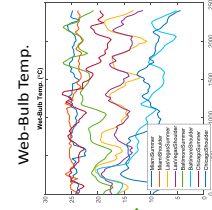

4 Chiller Plant Control Algorithms

Control Algorithms	Descriptions
1. Baseline Control	Constant chilled-water supply temp. (CHWST) setpoint of 7°C. Load based chiller staging logic.
2. OAR-based Reset (ASHRAE 90.1)	A linear schedule to reset CHWST setpoint based on outdoor air temperature (ASHRAE 90.1). Load based chiller staging logic.
3. Heuristic-based (Time-Response)	Non-response logic resets CHWST setpoint based on the demand measured by AHU's chilled-water valve position. The chilled-water valve position becomes greater than a prescribed threshold (e.g., 80%). Load based chiller staging logic.
4. Low-Cost Optimal	Maximize CHWST setpoint while performing real-time load estimation. Load based chiller staging logic.

12

LOW-COST OPTIMAL CONTROL

$$\text{Average} = \frac{1}{N} \left(\sum_{i=1}^N E_{\text{cooling}} - \sum_{i=1}^N E_{\text{cooling,optimal}} \right) / \sum_{i=1}^N E_{\text{cooling,optimal}}$$

Average Energy Savings (%) from Low-Cost Optimal Control

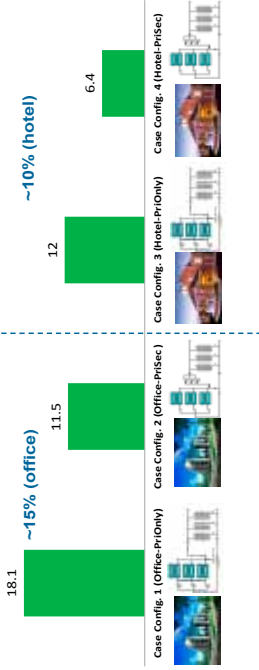

13

CONCLUSIONS

Better performing and more robust products

- **Physics based dynamic modeling and control enabling**
 - Control architecture (actuation/sensing) trade-off analysis
 - Algorithm analysis and design
 - Installation/commissioning guidelines development
 - Software robustness testing
 - Equipment diagnostics development
- **No turn-backs or surprises after the products are developed/deployed**

14

DANIEL RIVERA

ARIZONA STATE UNIVERSITY

A Process Control Perspective to Managing Production-Inventory Systems: Modeling, Forecasting, and Control

Production-inventory systems are iconic dynamical systems that are meaningful to applications in process settings and beyond. In this talk we focus on the classical single-node production-inventory system, and survey some recent published work from our laboratory addressing modeling, control, and demand forecasting considerations. A combined feedback-feedforward, three degree-of-freedom (3 DoF) Internal Model Control (IMC) algorithm is presented as useful in understanding fundamental control requirements for this system, but in practice a Model Predictive Control (MPC) algorithm is required. A standard MPC solution is contrasted with IMC, which ultimately leads to an improved MPC formulation that mimics the positive attributes of the 3 DoF IMC control system while addressing practical requirements such as constraint handling. Feedforward compensation of demand forecasts is critical to the performance of the closed-loop system; borrowing from the field of control-relevant identification, an analysis procedure for estimating demand models is presented which relies on sensible prefiltering of the demand data to emphasize the goodness-of-fit in the regions of time and frequency most important for achieving desired levels of closed-loop performance. The various points of the presentation are illustrated with meaningful examples.



Production-Inventory Systems: Modeling, Forecasting and Control

Daniel E. Rivera

Control Systems Engineering Laboratory
School for the Engineering of Matter, Transport and Energy
Ira A. Fulton Schools of Engineering
Arizona State University

<http://csel.asu.edu>

Outline

- Dynamical Model of a Production-Inventory System
- Control Strategies:
 - IMC-PID and 2DoF Feedback-Only IMC
 - 3DoF Combined Feedback/feedforward IMC
 - Model Predictive Control (MPC)
 - Improved MPC algorithm / Hybrid MPC
- Control-relevant Demand Modeling / Demand Forecasting
- Summary and Conclusions

Production-Inventory Systems: modeling, CONTROL, and Forecasting

Daniel E. Rivera

Control Systems Engineering Laboratory
School for the Engineering of Matter, Transport and Energy
Ira A. Fulton Schools of Engineering
Arizona State University

with special acknowledgments to:
Jay D. Schwartz, Intel Corp.
Naresh N. Nandola, ABB

Production-Inventory System

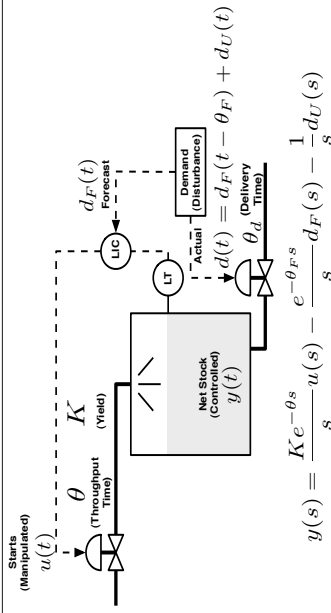

Semiconductor Manufacturing Supply Chain Management

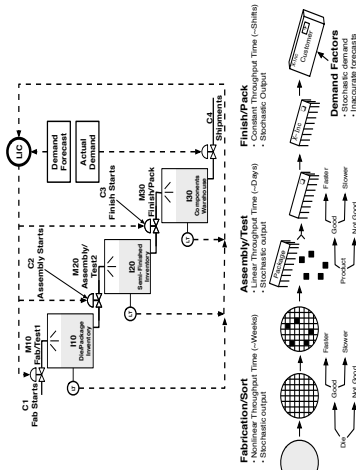

Global Warming/Climate Change



From National Geographic Magazine
(<http://ngm.nationalgeographic.com/big-idea/05/carbon-bath>)

Whole Hospital Occupancy

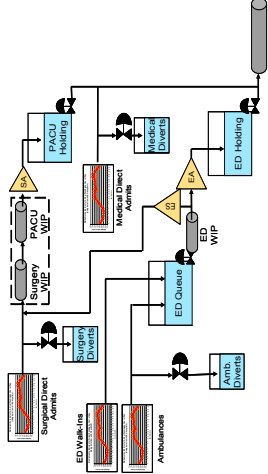

- Roche, K.T., D.E. Rivera, and J.K. Cochran, "A control engineering framework for managing whole hospital occupancy," *Mathematical and Computer Modelling*, Vol. 55, Issues 3-4, pgs. 1401 - 1417, February 2012.

Parental Function-Home Visits Behavioral Intervention as a Production-Inventory Control Problem

Parental function $PF(t)$ is built up by providing an intervention $I(t)$ (frequency of home visits), that is potentially subject to delay, and is depleted by potentially multiple disturbances (adding up to $D(t)$).

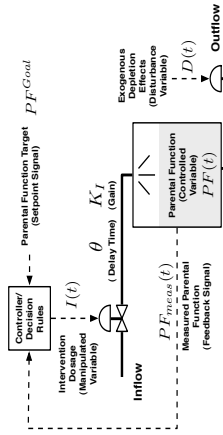

$$PF(t+1) = PF(t) + K_I I(t - \theta) - D(t)$$

- Rivera, D.E., M.D. Pew, and L.M. Coffins, "Engineering approaches for the design and analysis of adaptive, dynamic control systems: A Case Study in Dependence," Special Issue on Adaptive Treatment Strategies, Vol. 88, Supplement 2, pgs. 531-540, (2007).

Internal Model Control (IMC) Design Procedure

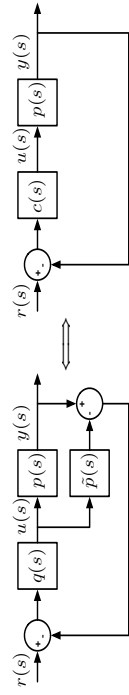

- Step 1 (Nominal Performance): Obtain an H_2 (ISE)-optimal $q(s)$
 - An external input form is specified (e.g., step or ramp)
 - Closed-form solution for $q(s)$ is obtained
 - Resulting controller is stable and causal
- Step 2 (Robust, Stability, and Performance)
 - Augment the IMC controller from Step 1 with a filter, $f(s)$.
 - Proper choice and tuning of the filter ensures that the final controller $\tilde{q}(s)$ is proper.
 - the control system achieves stability and performance under uncertainty.

IMC-PID Controller Response

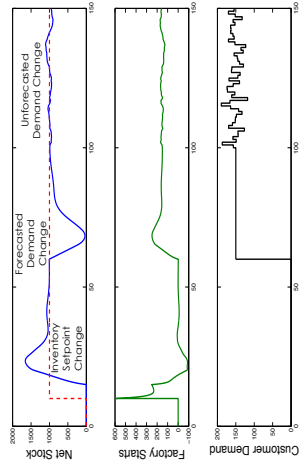

$$K = 1 \quad \theta = 5 \quad \theta_d = 0 \quad \lambda = 5$$

IMC-PID Tuning Rules

$$p(s) = \frac{K e^{-\theta s}}{s} \quad \tilde{p}(s) = \frac{K(-\frac{\theta}{2}s + 1)}{s(\frac{\theta}{2}s + 1)} \quad q(s) = \frac{s}{K(\lambda s + 1)}$$

Representing the delay with a first-order Padé approximation and applying the IMC design procedure leads to the PID with filter controller.

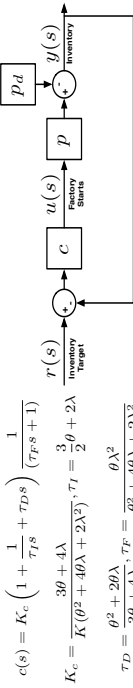

$$c(s) = K_c \left(1 + \frac{1}{T_I s} + T_D s \right) \frac{1}{(T_F s + 1)}$$

$$K_c = \frac{3\theta + 4\lambda}{K(\theta^2 + 4\theta\lambda + 2\lambda^2)}, \quad T_I = \frac{3}{2} \theta + 2\lambda$$

$$T_D = \frac{\theta^2 + 2\theta\lambda}{3\theta + 4\lambda}, \quad T_F = \frac{\theta\lambda^2}{\theta^2 + 4\theta\lambda + 2\lambda^2}$$

D.E. Rivera, M. Morari, and S. Skogestad, "Internal Model Control 4: PID Controller Design", *Ind. Eng. Chem. Process Des. Dev.*, **25**, 252-265, 1986.

Two Degree-of-Freedom (2DoF) Feedback-Only IMC

$$p(s) = \frac{K e^{-\theta s}}{s} \quad \tilde{p}(s) = \frac{K e^{-\theta s}}{s}$$

No approximation is applied to the plant delay.

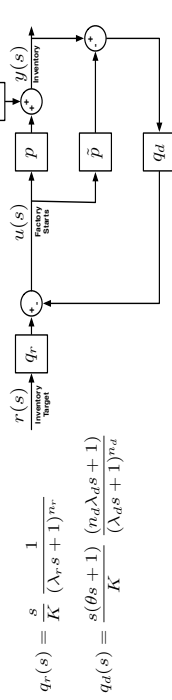

$$q_r(s) = \frac{s}{K} \frac{1}{(\lambda_r s + 1)^{n_r}}$$

$$q_d(s) = \frac{s(\theta s + 1)}{K} \frac{(n_d \lambda_d s + 1)^{n_d}}{(\lambda_d s + 1)^{n_d}}$$

J.D. Schwartz and D.E. Rivera, "A process control approach to tactical inventory management in production-inventory systems," *International Journal of Production Economics*, Volume 125, Issue 1, Pages 111-124, 2010.

2DoF Feedback-Only IMC

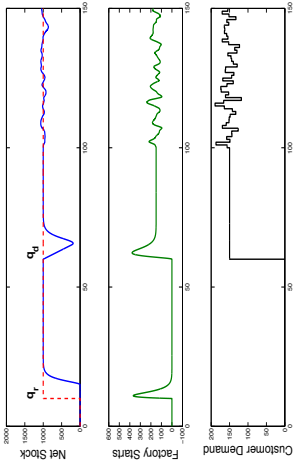

$$K = 1 \quad \theta = 5 \quad \theta_d = 0 \quad \lambda_r = 1 \quad n_r = 2 \quad \lambda_d = 2 \quad n_d = 3$$

3DoF Combined Feedback/Feedforward IMC Control

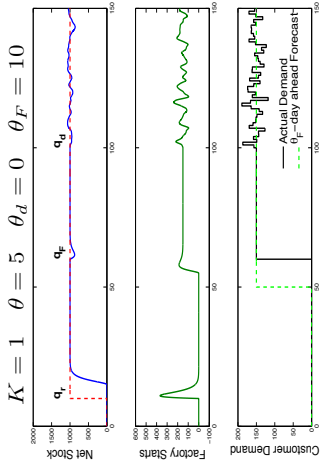

$$\lambda_r = 1 \quad n_r = 2 \quad \lambda_r = 1 \quad n_r = 3 \quad \lambda_d = 2 \quad n_d = 3$$

3DoF Combined Feedback/Feedforward IMC Control

$$p(s) = \frac{K e^{-\theta s}}{s}$$

$$\tilde{p}_d(s) = \frac{K e^{-\theta s}}{s}$$

$$p_d(s) = \frac{e^{-\theta_F s}}{s}$$

$$q_r(s) = \frac{s}{K} \frac{1}{(\lambda_r s + 1)^{n_r}}$$

$$q_d(s) = \frac{s(\theta s + 1)(n_d \lambda_d s + 1)}{K(\lambda_d s + 1)^{n_d}}$$

$$q_F(s) = \frac{e^{-(\theta_F - \theta_d - \theta)s} (n_F \lambda_F s + 1)}{K(\lambda_F s + 1)^{n_F}}, \quad \theta_F \geq \theta + \theta_d$$

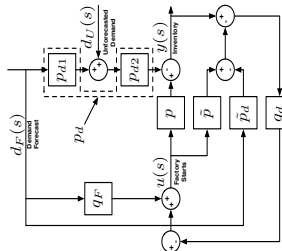

J.D. Schwartz and D.E. Rivera, "A process control approach to tactical inventory management in production-inventory systems," *International Journal of Production Economics*, Volume 125, Issue 1, Pages 111-124, 2010.

Model Predictive Control (MPC)

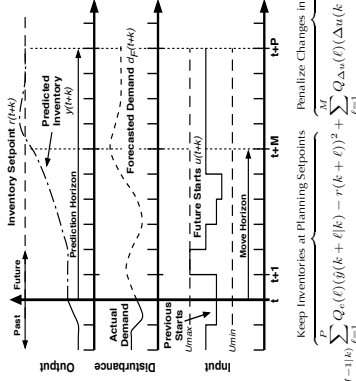

IMC/MPC Comparison

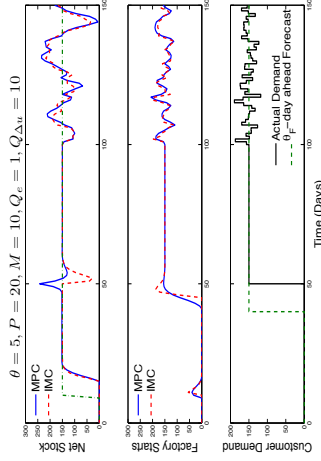

Some Observations

- Feedback-only control strategies (even if multi-degree-of-freedom) are unsatisfactory (in general).
- Combined feedback-feedforward strategies that rely on the availability of a demand forecast signal are necessary for good, comprehensive control.
- Model predictive control can provide useful functionality (e.g., constraint handling, anticipation) but the traditional move suppression/single-degree-of-freedom formulation can be lacking.

Constrained MPC (with Setpt Anticipation)

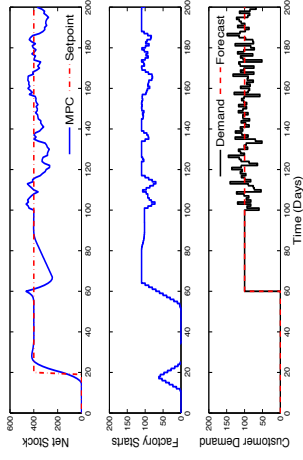

Simulation under conditions of active constraints in net stock and factory starts.

Motivation for an Improved MPC Formulation

- Integrating dynamics (i.e., ramp responses and disturbances)
- Need to take advantage of anticipated future system inputs (i.e., forecasted demand)
- Multiple degrees-of-freedom (forecasted + unforecasted demand + inventory setpoint tracking) with ease of tuning
- Ability to incorporate problem-specific constraints and possibly hybrid dynamics
- Robustness in the presence of stochasticity and nonlinearity

Nandola, N. and D. E. Rivera, "An Improved Formulation of Hybrid Model Predictive Control with Application to Production-Inventory Systems," *IEEE Trans. Control Systems Technology*, Vol. 21, No. 1, Pgs. 121-135, 2013.

Block Diagram for 3 DoF MPC Controller

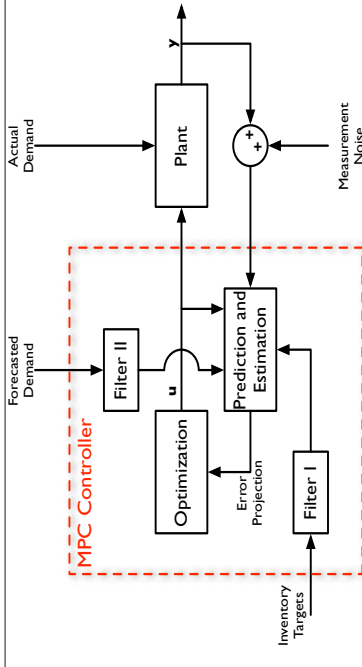

Three-degree-of-freedom (3-DoF) MPC tuning (cont.)

- State estimation and unmeasured disturbance rejection (J.H. Lee and Yu, *Computers and Chemical Engineering*, Vol. 18, No. 1, pgs. 15-37, 1994)

Step-A1: $X(k|k-1)$: one step ahead prediction using actual measured disturbance (d)

Step-A2: $X(k|k) = X(k|k-1) + K_x(y(k) - CX(k|k-1))$

Step-B1: $X_{frc}(k|k-D)$: one step ahead prediction using filtered measured disturbance (d_{frc})

Step-B2: $X_{frc}(k|k) = X_{frc}(k|k-1) + K_f(y(k) - CX(k|k-1))$

$$K_f = [0 \quad F_b \quad F_a]^T$$

$$F_a = \text{diag}\{(f_a)_1, \dots, (f_a)_{n_y}\}$$

$$F_b = \text{diag}\{(f_b)_1, \dots, (f_b)_{n_y}\}$$

$$(f_b)_j = \frac{(f_a)_j^2}{1 + \alpha_j - \alpha_j (f_a)_j}, \quad 0 \leq (f_a)_j \leq 1, \quad 1 \leq j \leq n_y$$

- $(f_a)_j$ is focused on each output j ; constrained to $0 \leq (f_a)_j \leq 1$
- Speed of dist. rejection is proportional to the tuning parameter $(f_a)_j$

Three Degree-of-Freedom (3-DoF) MPC Tuning

- Filter I for inventory target setpoint tracking (Type I /asymptotically step signals)

$$f_i(z) = \frac{(1 - \alpha_{Ii})z}{z - \alpha_{Ii}}, \quad i = 1, \dots, n$$

- Filter II for forecasted demand satisfaction (Type II /asymptotically ramp signals)

$$f_j(z) = \frac{[(1 - \alpha_{IIj}) + \frac{3}{5}\alpha_{IIj}]z - \frac{1}{5}\alpha_{IIj}z^{-1} - \frac{2}{5}\alpha_{IIj}z^{-2}}{1 - \alpha_{IIj}z^{-1}}, \quad j = 1, \dots, n$$

3-DoF MPC for Continuous Input

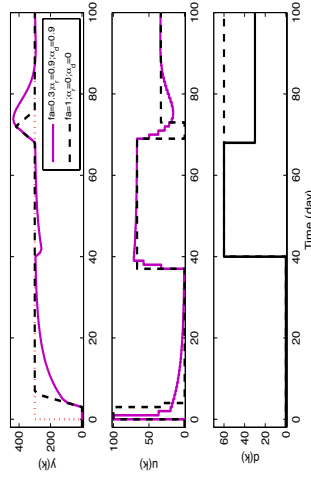

independent controller adjustment without the need for move suppression!

Controller Model (includes hybrid dynamics)

Plant Model Mixed Logical Dynamical (MLD) Framework

$$\begin{aligned} x_w(k+1) &= A_x x(k) + B_1 u(k) + B_2 \delta(k) + B_3 z(k) + B_d d(k) \\ y(k+1) &= C_x x(k+1) + d'(k+1) + \nu(k+1) \\ E_5 &\geq E_2 \delta(k) + E_3 z(k) - E_4 y(k) - E_1 u(k) + E_d d(k) \end{aligned}$$

d' : Unmeasured disturbance d : Measured disturbance

Disturbance Model

$$\begin{aligned} x_w(k+1) &= A_w x_w(k) + B_w w(k) \longrightarrow \text{Integrated white noise} \\ d'(k+1) &= C_w x_w(k+1) \\ A_w &= \text{diag}(\alpha_1, \alpha_1, \dots, \alpha_{r_y}), B_w = C_w = I \end{aligned}$$

MPC Objective Function

$$J \triangleq \sum_{i=1}^p \|(y(k+i) - \hat{y}_r)\|_{Q_y}^2 + \sum_{i=0}^{m-1} \|(\Delta u(k+i))\|_{Q_u}^2 + \sum_{i=0}^{m-1} \|(u(k+i) - u_p)\|_{Q_u}^2 + \sum_{i=0}^{p-1} \|(\delta(k+i) - \delta_r)\|_{Q_\delta}^2 + \sum_{i=0}^{p-1} \|(z(k+i) - z_r)\|_{Q_z}^2$$

Subject to

$$\begin{aligned} E_5 &\geq E_2 \delta(k+i) + E_3 z(k+i) - E_4 y(k+i) - E_1 u(k) + E_d d(k+i), 0 \leq i \leq p-1 \\ y_{\min} &\leq y(k+i) \leq y_{\max}, 1 \leq i \leq p \\ u_{\min} &\leq u(k+i) \leq u_{\max}, 0 \leq i \leq m-1 \\ \Delta u_{\min} &\leq \Delta u(k+i) \leq \Delta u_{\max}, 0 \leq i \leq m-1 \end{aligned}$$

Hybrid 3 DoF Model Predictive Control, Production-Inventory System

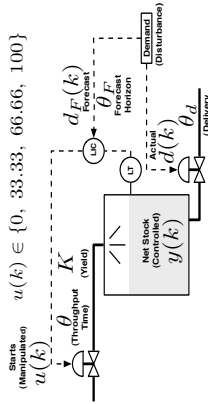

$$\begin{aligned} y(k+1) &= y(k) + K u(k) - (\theta - 1) - d(k) \\ d(k) &= \underbrace{d_f(k)}_{\text{forecasted}} + \underbrace{d_u(k)}_{\text{unforecasted}} \end{aligned}$$

Hybrid vs Continuous 3 DoF MPC Production-Inventory System

Continuous $u(t)$

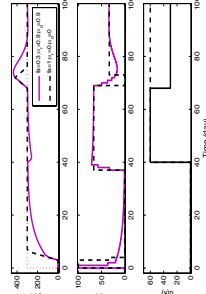

Discrete-level $u(t)$

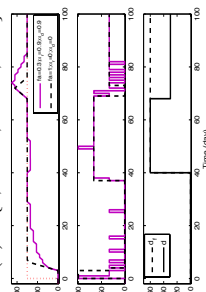

Solution involves solving a Mixed Integer Quadratic Program (MIQP) to address continuous error but discrete-level inputs (i.e., a hybrid problem).

Production-Inventory System in the Presence of Forecast Error

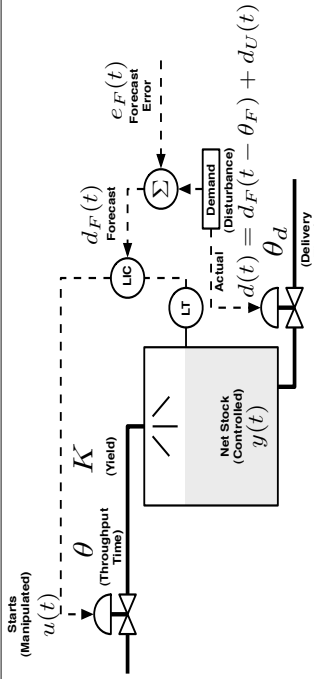

Understanding C-L Response to Forecast Error

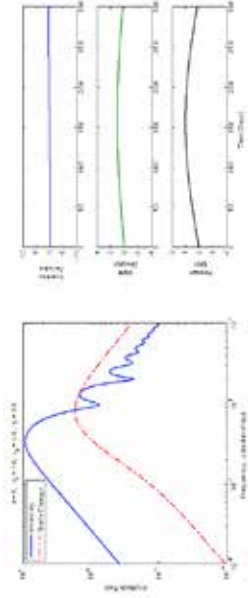

The effect of forecast error on closed-loop performance is most significant in an intermediate frequency range.

System Response to Forecast Error

The closed-loop system response to a unit pulse in forecast error provides a basis for understanding modeling requirements for control-relevant demand models.

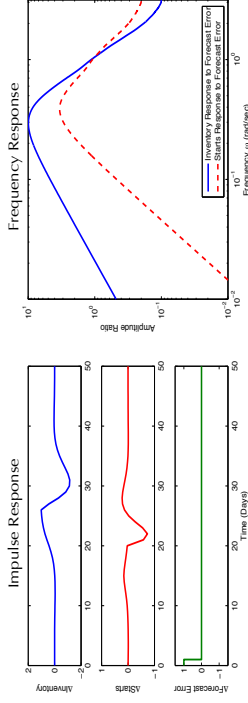

J.D. Schwartz and D.E. Rivera, "A control-relevant approach to demand modeling for supply chain management," *Computers and Chemical Engineering*, 70:78-90, 2014.

Response to Forecast Error (MPC, changing move suppression)

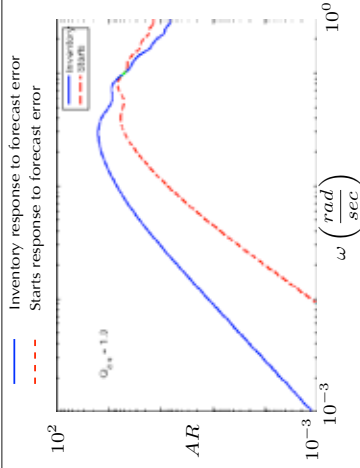

True demand is defined by a demand transfer function $p_d(z)$ and a stochastic component $H(z)a(t)$.

$$d(t) = p_d(z)u_d(t) + H(z)a(t)$$

The estimated demand is defined by $\tilde{p}_d(z)$ and a noise model $\tilde{p}_e(z)$.

$$\hat{d}(t) = \tilde{p}_d(z)u_d(t) + \tilde{p}_e(z)$$

The control-relevant estimation step consists of minimizing the one-step-ahead prediction error, where $L(z)$ is the prefilter.

$$\min_{\tilde{p}_d, \tilde{p}_e} V = \min_{\tilde{p}_d, \tilde{p}_e} \frac{1}{N} \sum_{t=1}^N |L(z)e(t)|^2 = \min_{\tilde{p}_d, \tilde{p}_e} \frac{1}{N} \sum_{t=1}^N e_{L,t}^2(t)$$

Parseval's theorem allows for frequency domain analysis of the problem.

$$\lim_{N \rightarrow \infty} \frac{1}{N} \sum_{t=1}^N e_{L,t}^2(t) = \frac{1}{2\pi} \int_{-\pi}^{\pi} |L(e^{j\omega})|^2 \left(|p_d(e^{j\omega})|^2 \Phi_{u_d}(\omega) + |H(e^{j\omega})|^2 \Phi_a(\omega) \right) d\omega$$

33

Multi-Objective Formulation (Cont.)

$$|L(e^{j\omega})|^2 = (1 - \gamma) |L_{cc}(e^{j\omega})|^2 + \gamma \lambda |L_{\Delta c}(e^{j\omega})|^2$$

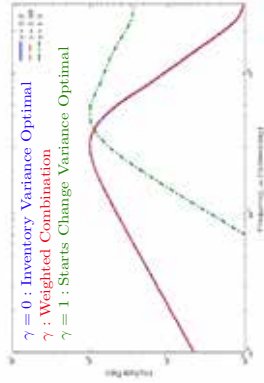

35

36

It is desirable to minimize a weighted combination of inventory and factory starts variance.

$$\min_{\tilde{p}_d, \tilde{p}_e} \left[\sum_{L=0}^{\infty} (1 - \gamma) e_L^2(t) + \lambda \sum_{L=0}^{\infty} \gamma \Delta e_L^2(t) \right]$$

The control-relevant prefilter then takes the following form.

$$\frac{|L(e^{j\omega})|^2}{|\tilde{p}_e(e^{j\omega})|^2} \Phi_{e,PF}(\omega) = (1 - \gamma) |L_{cc}(e^{j\omega})|^2 \Phi_{e,PF}(\omega) + \gamma \lambda |L_{\Delta c}(e^{j\omega})|^2 \Phi_{e,PF}(\omega)$$

By assuming an output error model structure, $L(z)$ can be reduced to the following form.

$$|L(e^{j\omega})|^2 = (1 - \gamma) |L_{cc}(e^{j\omega})|^2 + \gamma \lambda |L_{\Delta c}(e^{j\omega})|^2$$

A curve fitting procedure is then used to obtain an Infinite Impulse Response filter that matches the amplitude ratio of the control-relevant prefilter.

34

Final Observations

- Production-inventory systems are iconic dynamical systems that describe interesting problems in the process industries (and beyond).
- Combined feedback-feedforward strategies relying on demand forecast signals are necessary to adequately control these systems. Improved formulations of MPC can be developed in this regard.
- Demand modeling is a problem of significant importance in production-inventory systems; analysis of closed-loop decision policies show that these are most responsive to forecast error in an intermediate frequency bandwidth.
- Prefiltering can be used to apply the proper emphasis in control-relevant demand modeling.
- Multivariable extensions exist for both the control and demand modeling / demand forecasting segments of this presentation.

Primary References

- Schwartz, J.D., W. Wang, and D.E. Rivera, "Optimal tuning of process control policies for inventory management in supply chains," *Automatica*, 42, pgs. 1311- 1320, 2006.
- Wang, W. and D.E. Rivera, "Model predictive control for tactical decision-making in semiconductor manufacturing supply chain management," *IEEE Transactions on Control Systems Technology*, Vol. 16, No. 5, pgs. 841 - 855, 2008.
- Schwartz, J.D., M.R. Asghal, D.E. Rivera, and K.D. Smith, "Control-relevant demand forecasting for tactical decision-making in semiconductor manufacturing supply chain management," *IEEE Trans. on Semiconductor Mfg.*, Vol. 22, No. 1, pgs. 154 - 163, 2009.
- Schwartz, J.D. and D.E. Rivera, "A process control approach to tactical inventory management in production-inventory systems," *International Journal of Production Economics*, Volume 125, Issue 1, Pages 111-124, 2010.
- Nandola, N. and D. E. Rivera, "An Improved Formulation of Hybrid Model Predictive Control with Application to Production-Inventory Systems," *IEEE Trans. Control Systems Technology*, Vol. 21, No. 1, pgs. 121-135, 2013.
- Schwartz, J.D. and D.E. Rivera, "A control-relevant approach to demand modeling for supply chain management," *Computers and Chemical Engineering*, 70:78-90, 2014.

Additional references in <http://csel.asu.edu/SCMpapers>

Acknowledgements

- Intel Research Council
- National Science Foundation (DMI-0432439)
- National Institutes of Health (K25 DA021173 and R21 DA024266).
- Jay D. Schwartz, Naresh N. Nandola, Martin W. Braun, Wenlin Wang, Manuel Arahal, and Kirk D. Smith

CHRISTOS MARAVELIAS

UNIVERSITY OF WISCONSIN-MADISON

Online Scheduling: Basics, Paradoxes, and Open Questions

Production scheduling is one of the many planning functions in the process industries. In the last two decades there has been an increasing thrust towards using advanced optimization methods to compute better schedules. Hence, much work has been accomplished towards building realistic scheduling models and effective solution methods. Finding the schedule once, however, is only part of the whole scheduling process. Due to disruptions or arrival of new information, the incumbent schedule can become suboptimal or even infeasible, thus motivating the need for on-line (re)scheduling. Accordingly, in this talk we will investigate how the design of the open-loop problem affects the quality of the actual implemented schedule (closed-loop schedule). Towards this effort, we conceptualized and proposed a state-space scheduling model [1], thereby alleviating many of the difficulties associated with the use of conventional models for online scheduling. Using this model as our workhorse, we develop a framework for analyzing the relationship between the open-loop problem and the resulting closed-loop schedules.



First, we show that open-loop and closed-loop scheduling are two different problems, even in the deterministic case, when no uncertainty is present. We also show how equally good open-loop schedules can translate to very different closed-loop schedules, so much so, that it could mean a difference between no production vs. production at full capacity. In addition, we discuss a paradox, wherein solving a well-defined open-loop problem to optimality in every iteration leads to a worse closed-loop schedule, than if this same open-loop problem were to be solved to a suboptimal solution. Second, we discuss why it is important to reschedule periodically, even when there are no “trigger” events, something that is in contrast with the current approaches to rescheduling. Third, we show that suboptimality in the re-optimizations do not “accumulate”, but instead, are corrected through feedback. Fourth, we study how rescheduling frequency, moving horizon length and suboptimal solutions of open-loop problem affect the quality of

closed-loop schedules, and found that there exist certain threshold values, operating outside of which leads to bad closed-loop solutions. These thresholds, which depend on characteristics of the network facility, and the demand pattern, can be utilized to appropriately choose the online scheduling algorithm attributes. We also discuss that there is a cross-relation between these attributes, and hence, we should choose an appropriate value for all three in conjunction. Lastly, we explore objective function modifications and addition of constraints to the open-loop problem as effective methods to improve closed-loop performance. Notably, we show that adding constraints can possibly lead to lower quality open-loop solutions, but can ultimately result in higher quality closed-loop (implemented) solutions. We close with some open questions.

Online Scheduling: Basics, Paradoxes and Open Questions

Christos T. Maravelias
Department of Chemical and Biological Engineering
University of Wisconsin – Madison

Lund Center for Control of Complex Engineering Systems
Process Control Workshop
Lund, Sweden
September 27-30, 2016

Preliminaries

- Systematic scheduling practiced in manufacturing since early 20th century
- First scheduling publications in the early 1950s
- Sawson, M.E. On a quantitative method in production planning and scheduling. *Econometrica*, 20(9), 1952.
- Extensive research in 1970s
 - Closely related to developments in computing and algorithms
 - Computational Complexity, *Job Sequencing* one of 21 NP-complete problems in (Karp, 1972)
- Widespread applications
 - Airlines industry (e.g., fleet, crew scheduling); sports; transportation (e.g., vehicle routing)
 - Government; education (e.g., class scheduling); services (e.g., service center scheduling)
- Chemical industries
 - Batch process scheduling (e.g., pharma, food industry, fine chemicals)
 - Continuous process scheduling (e.g., polymerization)
 - Transportation and delivery of crude oil
- Scheduling in PSE
 - First publications in early 1980s; focused on sequential facilities (Rippin, Reklaitis)
 - Problems in network structures addressed in early 1990s (Pantelides et al)
- Very challenging problem: Small problems can be very hard
 - Most *Open* problems in MIPLIB are scheduling related
 - Railway scheduling: 1,500 constraints, 1,083 variables, 794 binaries
 - Production planning: 1,307 constraints, 792 variables, 240 binaries

1-1

Outline

- Introduction
 - Problem Classes
 - Types of Models
- General Model
 - State-task network (STN) representation
 - State-space STN model
 - Remarks
- Online scheduling
 - Open-loop vs. closed-loop solutions
 - Online scheduling algorithm

Problem Statement

- Given are:
- a) Production facility data: e.g., unit capacities, unit connectivity, etc.
 - b) Production recipes: i.e., mixing rules, processing times/rates, utility requirements, etc.
 - c) Production costs: e.g., raw materials, utilities, changeover, etc.
 - d) Material availability: e.g., deliveries (amount and date) of raw materials.
 - e) Resource availability: e.g., maintenance schedule, resource allocation from planning, etc.
 - f) Production targets or orders with due dates.

Facility and
recipe data

Input from other
planning functions

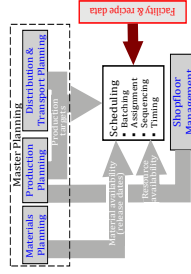

1-2

Problem Statement

Given are:

- a) **Production facility data**; e.g., unit capacities, unit connectivity, etc.
- b) **Production recipes**; i.e., mixing rules, processing times/rates, utility requirements, etc.
- c) **Production costs**; e.g., raw materials, utilities, changeover, etc.
- d) **Material availability**; e.g., deliveries (amount and date) of raw materials.
- e) **Resource availability**; e.g., maintenance schedule, resource allocation from planning, etc.
- f) **Production targets or orders with due dates**.

Our goal is to find a least cost schedule that meets production targets subject to resource constraints.

Alternative objective functions are the minimization of tardiness or lateness (minimization of backlog cost) or the minimization of earliness (minimization of inventory cost) or the maximization of profit.

In the general problem, we seek to optimize our objective by making four types of decisions:

- a) Selection and sizing of batches to be carried out (batching)
- b) Assignment of batches to processing units or general resources.
- c) Sequencing of batches on processing units.
- d) Timing of batches.

Task selection (batching)
What size?

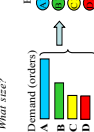

Task-resource Assignment
What resources can process each task/batch?

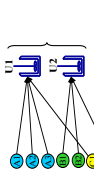

Sequencing (for many resources)
In what sequence are batches processed?

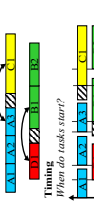

Timing
When do tasks start?

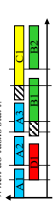

Problem Classes

$$\alpha / \beta / \gamma$$

- Machine environment**
 - Single machine
 - Parallel machines
 - ...
- Processing characteristics**
 - Preemption
 - Release/due times
 - ...
- Objective**
 - Makespan
 - Tardiness
 - Cost

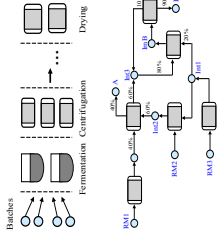

- **Sequential environment**
 - Problems similar to discrete manufacturing due to material handling restrictions
- **Network environment**
 - Batches and materials are split
 - Recycle streams, etc.
 - Problems different from discrete manufacturing
- **Hybrid environment**
 - Consist of different types of subsystems

Mendez et al., (2006); Maravelias (2012)

1-2

From Environments to Models

Math Programming Scheduling Models in the PSE literature (1980 – 2007):

- For **sequential** processes we developed **batch-based** approaches
 - **Track batches**; do not account for material amounts
 - **Fixed number and size of batches**; only assignment and sequencing decisions; no batching

Task selection (batching)
Batches

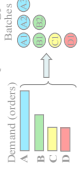

Task-resource Assignment

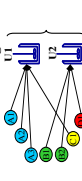

Sequencing



Other common assumptions

- No storage constraints
- No utility requirements

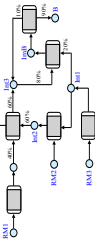

Also account for:

- Storage constraints
- Utility requirements
- Transfer operations
- Blending

1-4

Modeling Attributes

- **Key modeling entities**
 - Batches/tasks
 - Material amounts
 - Both
- **Scheduling decisions**
 - Task number & size (batching)
 - Task-unit assignment
 - Sequencing/timing

II. Scheduling Decisions

	Sequencing/timing	Unit-batch assignment	Batching (no & size)
Tasks	Sequential, no batching	Sequential, no batching	Sequential, no batching
Materials	Single-unit	Multi-stage, multi-purpose	Unit-batch assignment
materials			1. Network processes 2. Network & sequential processes
materials			Sequential with batching

1. Key Modeling Elements

1-5

Modeling Attributes

- Key modeling entities
 - Batches/tasks
 - Material amounts
 - Both
- Scheduling decisions
 - Task number, & size (batching)
 - Task-unit assignment
 - Sequencing/timing
- Modeling of time (four types of decisions)
 - Selection between precedence based and time-grid-based approaches
 - Selection of (i) type of precedence relationship (local vs. global) (ii) type of time grid (common vs. unit specific)
 - Specific representation assumptions
 - Selection between discrete- and continuous-time

Levels

- Precedence vs. time grid
- Type of precedence /grid
- Specific assumptions
- Time representation

III. Modeling of time

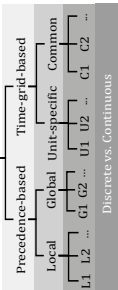

The Universe of Modeling Approaches

1-5

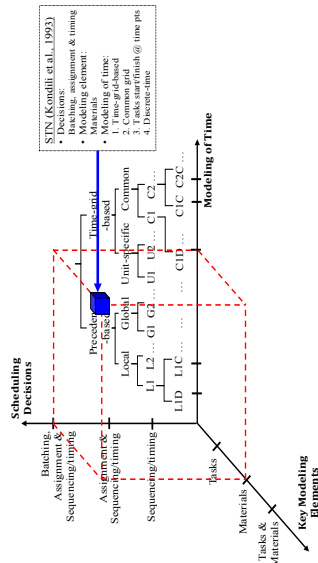

1-6

The Universe of Modeling Approaches

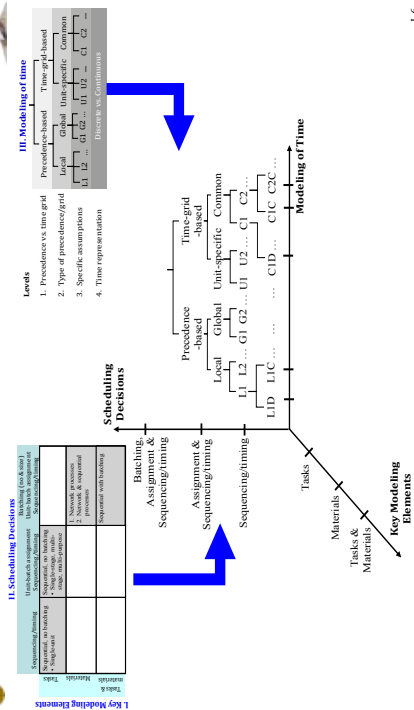

1-6

Remarks

Major modeling advances recently

- Sequential Environments
 - Simultaneous batching, assignment, sequencing¹
 - Storage policies and general resource constraints^{2,3}
 - Network environments
 - Resource-constrained material transfers and changeover activities⁴
 - Combined environments⁵
 - upstream sequential followed by downstream network, followed by continuous processing e.g.,
- ### Outstanding modeling challenges
- Sequence-dependent changeovers
 - Nonlinear models (blending)
- ### Major computational advances
- Constraint propagation⁶ and reformulation methods⁷
 - Computational improvements of 1-2 orders of magnitude^{8,9}
 - Applicable to wide range of models and problem classes

¹ Prasad & Manavalas, *Comp. & Chem. Eng.*, 32 (6), 2008.

² Sundaramoorthy & Manavalas, *Ind. Eng. Chem. Res.*, 48 (13), 2009.

³ Sundaramoorthy & Manavalas, *Ind. Eng. Chem. Res.*, 48 (13), 2009.

⁴ Gimenez et al., *Comp. & Chem. Eng.*, 33 (10), 2009.

⁵ Sundaramoorthy & Manavalas, *AIChE J.*, 57 (3), 2011.

⁶ Velaz et al., *AIChE J.*, 59(3), 2013.

⁷ Sundaramoorthy & Manavalas, *Ind. Eng. Chem. Res.*, 48 (13), 2009.

⁸ Velaz & Manavalas, *Ann. Rev. Chem. Biom. Eng.*, 5, 97-121, 2014.

⁹ Velaz et al., *Chem. Eng. Sci.*, 136, 139-157, 2015.

Outline

- **Introduction**
 - Problem Classes
 - Types of Models
- **General Model**
 - State-task network (STN) representation
 - State-space STN model
 - Critical insights
- **Online scheduling**
 - Open-loop vs. closed-loop solutions
 - Online scheduling algorithm

Unified Framework

- **Unified framework**
 - Material-based representation of all types of processing
 - Sequential processing represented using materials with special properties (constraints)
- **Basic concepts** (from STN; Kondili et al., 1993)
 - Processing units, $j \in J$
 - Processing tasks $i \in I$ (duration, τ_i ; batchsize, β_i)
 - Materials (states), $m \in M$ (storage capacity, $s_{m,t}$)
- **Discrete-time representation**
 - Horizon, η , partitioned into T time periods, $t \in T$, of length $\delta = \eta/T$
- **Decision variables**
 - $W_{i,t} \in \{0, 1\}$: inventory level of material m during period t
 - $S_{m,t} \in [0, s_{m,t}]$:
- **Mixed-integer programming (MIP) model**
 - Resource constraint: a unit can process at most one task at a time
 - Material balance: calculation of inventory over time

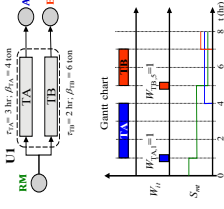

Can we express the general scheduling MIP model in state-space form?

Mixed-integer Programming Model

- Resource constraints
 - Decision variable: $W_{i,t} = 1$ when a task starts
-
- $$W_{i,t} + W_{i,t+1} + \sum_{t=2\delta}^{t+\delta} W_{i,t} \leq 1 \Rightarrow \sum_{t=2\delta}^{t+\delta} W_{i,t} \leq 1, \forall i, t$$
- Material balance constraints
 - Inventory levels ($S_{m,t}$) are the results of our scheduling decisions $W_{i,t}$

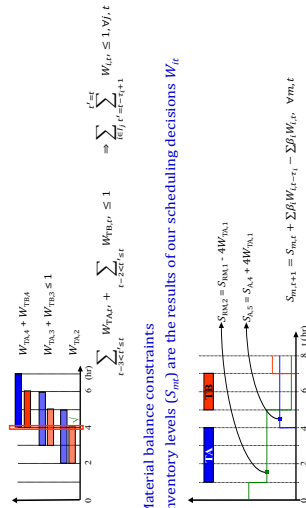

II-2

Scheduling State-space Model

- Inputs: task start, $W_{i,t}$
 - States: material inventory level, $S_{m,t}$
- The state of the system is not fully described
- $$\begin{aligned} W_{1,t+\delta}^0 &= 1, W_{2,t+\delta}^0 = 0, W_{3,t+\delta}^0 = 0 \\ W_{1,t+\delta}^1 &= 0, W_{2,t+\delta}^1 = 1, W_{3,t+\delta}^1 = 0 \end{aligned}$$
- Lifting of task variables
- $$\begin{aligned} W_{1,t+\delta}^0 &= 1 \\ W_{2,t+\delta}^0 &= W_{1,t+\delta}^0 = 1 \\ W_{3,t+\delta}^0 &= W_{1,t+\delta}^0 = W_{2,t+\delta}^0 = 1 \\ W_{1,t+\delta}^1 &= W_{1,t+\delta}^0 = 1 \\ W_{2,t+\delta}^1 &= W_{1,t+\delta}^0 = 1 \end{aligned}$$
- Material balances: $S_{m,t+1} = S_{m,t} + \sum_{i \in I} \beta_i W_{i,t} - \sum_{j \in J} \beta_j W_{j,t}$
 - Resource constraints: $\sum_{i \in I} W_{i,t} \leq 1$

II-3

Remarks - I

- General state-space scheduling model
- Inventory control* – scheduling integration for supply chain management
- Scheduling* – control integration
- MPC-friendly* scheduling model; use existing and develop new results

Standardize rescheduling

- Currently, unclear what rescheduling means
- Keep the same state-space model; infer reformulation of the MIP model
- Reverse transformation: state-space model + disturbances → MIP model

Questions:

- What are input/output setpoint trajectories?
- What does stability mean in scheduling?
- What do terminal regions/penalties mean? How can we generate them?

Remarks - II

Rescheduling viewed as Optimization Under Uncertainty problem

- Demand: right-hand-side (RHS) uncertainty ↕
- Task yields: left-hand-side (LHS) ↕
- Unit delay ?
- LHS parametric uncertainty in continuous-time
- Structural uncertainty in discrete-time models
- Unit breakdown ✗
- Endogenous uncertainty

Treat scheduling as (deterministic) online problem

- Develop models and methods for deterministic problem
- Model all *uncertainties* through disturbances (state-space model)
- Solve deterministic problem **fast**
 - Optimal deterministic solution better than suboptimal stochastic solution
 - Reschedule more frequently to respond to disturbances
 - Consider longer-planning horizons

Outline

- Introduction
 - Problem Classes
 - Types of Models
- General Model
 - State-task network (STN) representation
 - State-space STN model
 - Remarks
- Online scheduling
 - Open-loop vs. closed-loop solutions
 - Online scheduling algorithm

II-8



Rescheduling - Motivation

- (A) Schedule to meet an order for 12 tons of M2 and M3 each due at $t = 13$.
- (B) A delay in T3 (due to electric-power-loss) between $t = 3$ and $t = 4$, requires right-shifting of the schedule. This results in part of the order (7 tons) delayed.
- (C) Instead of simple right-shift, the schedule is recomputed at $t = 4$, thereby, reducing the part of the order delayed (to 2 tons).

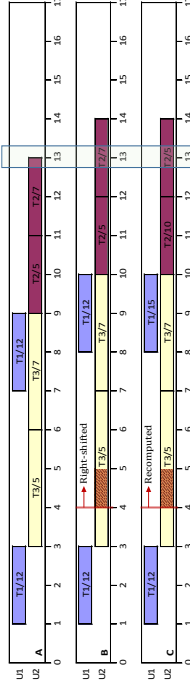

II-9



Literature:

- We need rescheduling to act upon **trigger events**.
- By reacting, we mitigate effect of trigger events (uncertainty/disturbances)
- Even better: account for uncertainty (in trigger events?)

III-1

Open-loop vs. Closed Loop Schedules

- Traditional Approach: Solve problem the best way possible & react if/when necessary
- Is this really all?
- Use simulation to study what happens in reality

Simulation Framework

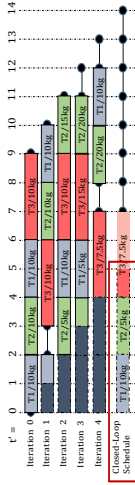

Open-loop vs. Closed Loop Solution

Experiment #1

- Re-optimize at every t using horizon $T = 5$ hr
- Maximize profit using Shah (1993) model
[max $S_{M,LT} - \text{Inventory Costs}$]
- What do we expect at $t = 0$?

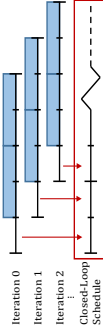

Left-shifted by favoring early sales in objective

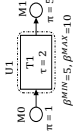
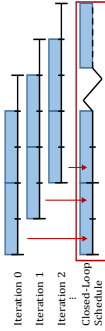

III-2

Open Loop vs. Closed Loop Solution

Experiment #2

- Orders of size 4 tons due every 3 h for each product (M5-M7)
- The facility starts at $t = 0$ with a safety stock (inventory) of product materials sufficient to meet two orders ($t = 3, 6$)
- Use horizon $\eta = 8$ hr.

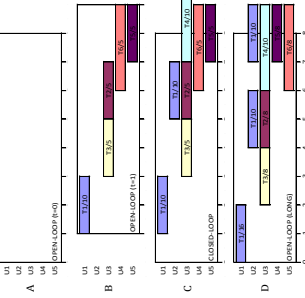
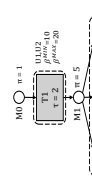

- (A) Open-loop (at $t = 0$) with moving horizon length 8 h, as an empty schedule and inventory holding cost of \$26,400.
- (B) Production starts in open-loop (at $t = 1$) and the objective value for this open-loop solution is \$31,005.
- (C) Resulting closed-loop schedule from solution to 8 open-loop problems (solved at $t = 0, 1, 2, \dots, 7$ respectively), with an evaluated cost of \$27,359.
- (D) Gantt chart for first 8 h, of a long open-loop problem solved spanning $t = 0$ to $t = 15$; cost for the first 8 periods is \$29,592.

III-4

III-3

Open Loop vs. Closed Loop Solution

Experiment #3

- Orders of 3 tons for each product are due every 3 ± 1 hr
- Excess sales are allowed when orders are due
- The objective is to maximize profit.
- Objective is modified to favor early sales so excess inventory is shipped as soon as possible.
- Since T2 takes less time, M2 can be produced at a faster rate; thus, executing T2 leads to more profit.
- Best schedule: T2 dominates; T3 has the minimum possible # of batches; just to meet M3 demand.

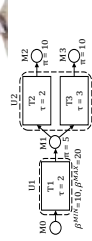

Closed Loop Schedules with 0 and 5% Optimality Gap

- Deterministic data; $\eta = 12$ hr
- Closed-loop solutions generated for 1 week
- With OPTCR = 0%, T3 is executed 25 times
- With OPTCR = 5%, T3 is executed 21 times
- Suboptimal open-loop solutions lead to better closed loop (implemented solutions)

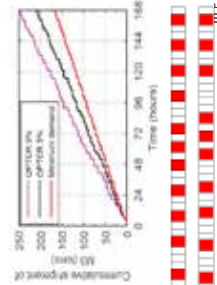

III-5

Uncertainty vs. New Information

Experiment #4

- Have to meet orders of 12 tons for M2 and M3, each due every 6 hours starting at $t=12$
- Use horizon $\eta = 16$ hr

(A) Schedule computed at $t=0$.

(B) At $t=5$, the uncertainty in order due at $t=12$ is observed; the order becomes 12 tons of M3 and 15 tons M2.

Remaining schedule from $t=5$ onwards is recomputed and implemented.

(C) At $t=5$, the 16-hr horizon is advanced to span $t=5$ to $t=21$; the orders at $t=12$ remain the same. The new schedule is recomputed to account for a new order due at $t=18$.

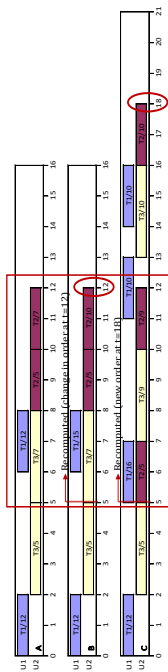

- The difference between A and C is bigger than the difference between A and B
- Accounting for new information can be more important than accounting for uncertainty

Some Analysis

- There are threshold MH, RF, and OPTCR values which are functions of facility & demand
- Three attributes are inter-related; e.g., horizon compensates for slow frequency

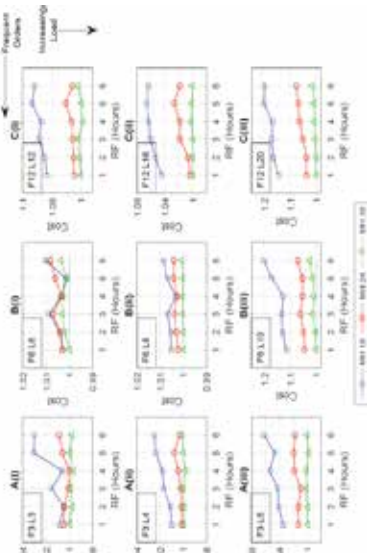

Conclusions

- Open-loop and closed-loop scheduling are two different problems
- Have to re-optimize even if there are no trigger events
- How can we obtain good closed-loop solutions?

1) Online scheduling algorithm

- How often should we re-optimize (rescheduling frequency)?
- How long should the horizon be?
- What is a good optimality gap?

2) Open-loop model

- What objective function should we use?
- Anything else?

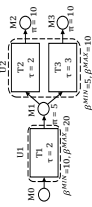

III-6



... and Some Answers

Experiment #3 revisited

- Orders of 3 tons for each product are due every 3 ± 1 hr
- Max. Profit with excess sales when orders are due
- Favoring early sales is bad idea: excess cheap product is sold, so new batches should be started to meet future demand. It is better to NOT sell early on.
- Model modification: no excess sales allowed during the first 6 hr

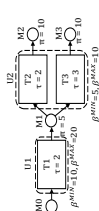

III-7

Closed loop schedules for unit 2:

- (A) MH = 12, OPTCR = 0%; T3 is executed 25 times
- (B) MH = 12, OPTCR = 5%; T3 is executed 21 times
- (C) MH = 12, OPTCR = 5%, plus no sales constraint; T3 is executed 17 times (best).
- (D) MH = 12, OPTCR = 0%, no obj function modification; T3 is executed 18 times but T2 is executed fewer times (lower profit)

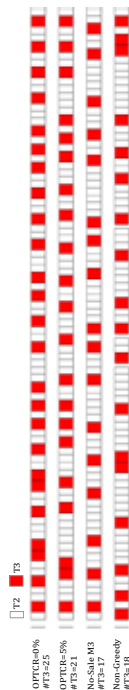

III-8

III-9



Final Thoughts



- **Chemical production scheduling**
 - *Most* modeling challenges addressed
 - Major computational advances
 - **Unsolved problems**
 - Sequence-dependent changeovers, nonlinear models
- **From rescheduling to online scheduling**
 - State-space STN model facilitates representation
 - **Deterministic problem**
 - Consider larger problem
 - Re-optimize faster
- **Open questions**
 - **Open-loop problem modifications**
 - **Online scheduling algorithm attributes**

SIGURD SKOGESTAD

NORWEGIAN UNIVERSITY OF SCIENCE AND TECHNOLOGY

A systematic procedure for economic plantwide control

A chemical plant may have thousands of measurements and control loops. By the term plantwide control it is not meant the tuning and behavior of each of these loops, but rather the control philosophy of the overall plant with emphasis on the structural decisions. In practice, the control system is usually divided into several layers, separated by time scale: scheduling (weeks), site-wide optimization (day), local optimization (hour), supervisory and advanced control (minutes) and regulatory control (seconds). Such a hierarchical (cascade) decomposition with layers operating on different time scale is used in the control of all real (complex) systems including biological systems and airplanes, so the issues in this section are not limited to process control. In the talk the most important issues are discussed, especially related to the choice of "self-optimizing" variables that provide the link the control layers. Examples are given for optimal operation of a runner and distillation columns.



A systematic procedure for economic plantwide control

Sigurd Skogestad

Department of Chemical Engineering
Norwegian University of Science and Technology (NTNU)
Trondheim, Norway

Lund, 29 Sept. 2016

Outline

- Our paradigm based on time scale separation
- Plantwide control procedure based on economics
- Example: Runner
- Selection of primary controlled variables (CV_i=H_iy)
 - Optimal is gradient, CV_i=1, with setpoint=0
 - General CV_i=Hy. Nullspace and exact local method
- Throughput manipulator (TPM) location
- Examples
- Conclusion

This is the truth and the only truth



How we design a control system for a complete chemical plant?

- Where do we start?
- What should we control? and why?
- etc.
- etc.

In theory: Optimal control and operation

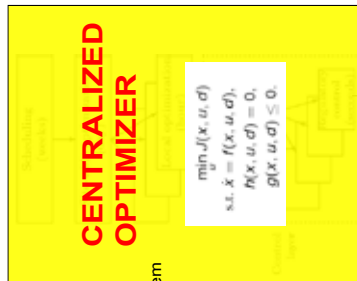

Objectives
Present state
Model of system

(Physical) Degrees of freedom

Approach:

- Model of overall system
- Estimate present state
- Optimize all degrees of freedom

Process control:

- Excellent candidate for centralized control

Problems:

- Model not available
- Objectives = ?
- Optimization complex
- Not robust (difficult to handle uncertainty)
- Slow response time

• Alan Foss ("Critique of chemical process control theory", AIChE Journal, 1973):

The central issue to be resolved ... is the determination of control system structure. Which variables should be measured, which inputs should be manipulated and which links should be made between the two sets? There is more than a suspicion that the work of a genius is needed here, for without it the control configuration problem will likely remain in a primitive, hastily stated and wholly unmanageable form. The gap is present indeed, but contrary to the views of many, it is the theoretician who must close it.

Previous work on plantwide control:
 -Raghu Bickley (1984) - Chapter on "Overall process control" (still industrial practice)
 -Greg Shinskey (1997) - process control systems
 -Bill Lyden et al. (1975 -) - case studies: "snowball effect"
 -George Stephanopoulos and Manfred Morari (1980) - synthesis of control structures for chemical processes
 -Jim Downs (1991) - Tennessee Eastman challenge problem
 -Larsen and Skogestad (2000): Review of plantwide control

Practice: Engineering systems

- Most (all?) large-scale engineering systems are controlled using hierarchies of quite simple controllers
 - Large-scale chemical plant (refinery)
 - Commercial aircraft
- 100's of loops
- Simple components:
 - PI-control + selectors + cascade + nonlinear fixes + some feedforward

Same in biological systems

But: Not well understood

NTNU

7

Our Paradigm

Practical operation: Hierarchical structure

OBJECTIVE

Min J (economics)

Follow path (+ look after other variables)

Stabilize + avoid drift

CV = controlled variable (with setpoint) interconnect the layers

Main objectives control system

1. **Economics:** Implementation of acceptable (near-optimal) operation
2. **Regulation:** Stable operation

ARE THESE OBJECTIVES CONFLICTING?

- **Usually NOT**
 - Different time scales
 - Stabilization fast time scale
 - Stabilization doesn't "use up" any degrees of freedom
 - Reference value (setpoint) available for layer above
 - But it "uses up" part of the time window (frequency range)

NTNU

9

Control structure design procedure

I Top Down (mainly steady-state economics, Y_1)

- Step 1: Define operational objectives (optimal operation)
 - Cost function J (to be minimized)
- Step 2: Identify degrees of freedom (MVs) and optimize for expected disturbances
 - Identify **Active constraints**
 - Step 3: Select primary "economic" controlled variables CV_1 (CV1s)
 - **Self-optimizing variables (find H)**
- Step 4: Where locate the **throughput manipulator (TDM)?**

II Bottom Up (dynamics, Y_2)

- Step 5: Regulatory / stabilizing control (PID layer)
 - What more to control (δ : local CV2s)? **Find H_1**
- Step 6: Supervisory control (MPC layer)
- Step 7: Real-time optimization (Do we need it?)

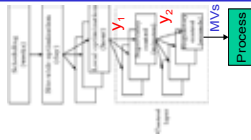

Degrees of freedom for optimization (usually steady-state DOFs), $MV_{opt} = CV_1$'s
 Degrees of freedom for supervisory control, $MV_1 = CV_2$'s + unused valves
 Physical degrees of freedom for stabilizing control, $MV_2 =$ valves (dynamic process inputs)

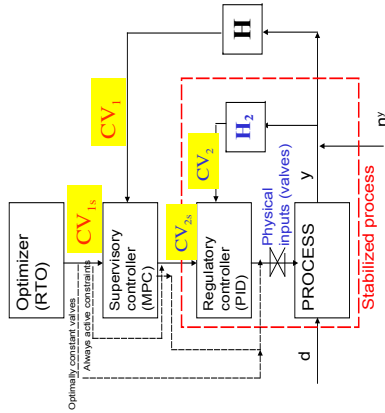

12

Step S2. Optimize

- Identify degrees of freedom
- Optimize for expected disturbances

- Need good model, usually steady-state
- Optimization is time consuming! But it is offline
- Main goal: Identify **ACTIVE CONSTRAINTS**
- A good engineer can often guess the active constraints

13

Step 1. Define optimal operation (economics)

- What are we going to use our degrees of freedom u (MVs) for?
- Define scalar cost function $J(u,x,d)$
 - u : degrees of freedom (usually steady-state)
 - d : disturbances
 - x : states (internal variables)
- Typical cost function:

$J = \text{cost feed} + \text{cost energy} - \text{value products}$
- Optimize operation with respect to u for given d (usually steady-state):

$$\min_u J(u,x,d)$$

subject to:

$$\begin{aligned} \text{Model equations:} & f(u,x,d) = 0 \\ \text{Operational constraints:} & g(u,x,d) < 0 \end{aligned}$$

14

15

Optimal operation of runner

- Cost to be minimized, $J=T$
- One degree of freedom (u =power)
- What should we control?



2. Optimal operation of Marathon runner

- 40 km, $J=T$
- What should we control? $CV=?$
- **Unconstrained optimum**

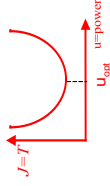

Step S3: Implementation of optimal operation

- Have found the optimal way of operation.
How should it be implemented?
- **What to control ?** (CV_1).
 1. Active constraints
 2. Self-optimizing variables (for unconstrained degrees of freedom)



1. Optimal operation of Sprinter

- 100m, $J=T$
- **Active constraint control:**
 - Maximum speed ("no thinking required")
 - $CV = \text{power (at max)}$



Self-optimizing control: Marathon (40 km)

- Any **self-optimizing variable** (to control at constant setpoint)?

- c_1 = distance to leader of race
- c_2 = speed
- c_3 = heart rate
- c_4 = level of lactate in muscles



Summary Step 3. What should we control (CV_1)?

Selection of primary controlled variables $c = CV_1$

- Control active constraints!**
- Unconstrained variables: Control self-optimizing variables!**

- Old idea (Morari *et al.*, 1980):

"We want to find a function c of the process variables which when held constant, leads automatically to the optimal adjustments of the manipulated variables, and with it, the optimal operating conditions."

Conclusion Marathon runner

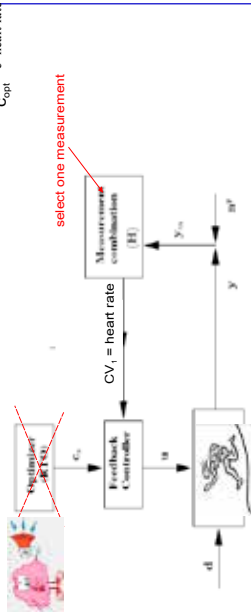

- CV = heart rate is good "self-optimizing" variable
- Simple and robust implementation
- Disturbances are indirectly handled by keeping a constant heart rate
- May have infrequent adjustment of setpoint (c_3)

Unconstrained degrees of freedom

The ideal "self-optimizing" variable is the gradient, J_u

$$c = \partial J / \partial u = J_u$$

- Keep gradient at zero for all disturbances ($c = J_u = 0$)
- Problem: Usually no measurement of gradient

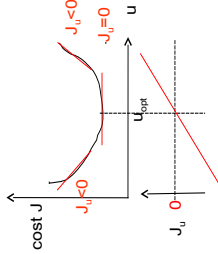

The ideal "self-optimizing" variable is the gradient, J_u

$$c = \partial J / \partial u = J_u$$

- Keep gradient at zero for all disturbances ($c = J_u = 0$)
- Problem: Usually no measurement of gradient

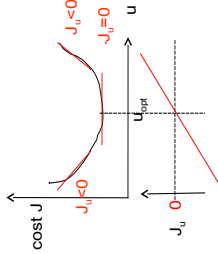

$CV_1 = Hy$

Nullspace method for H (Alstad):

HF=0 where $F = dy_{opt}/dd$

$$J_u(u, d) = \underbrace{J_u(u_{opt}(d), d)}_{=0} + J_{dist} \cdot (u - u_{opt})$$

$u - u_{opt} = (HG^y)^{-1}(c - c_{opt})$
 Here: $c - c_{opt} = \Delta c = \Delta c_{opt}$
 where we have introduced deviation variables around a nominal optimal point (c^*, u^*) (where $c^* = c_{opt}(r^*)$)
 Assume perfect control of c (no noise): $\Delta c = 0$
 Optimal change: $\Delta c_{opt} = H\Delta_{input} = HF\Delta d$
 Gives $J_u = -J_{opt}(HG^y)^{-1}HF\Delta d$
 $\Rightarrow HF = 0$ gives $J_u = 0$ for any disturbance Δd

Example. Nullspace Method for Marathon runner

$u = \text{power}$, $d = \text{slope [degrees]}$
 $y_1 = \text{hr [beat/min]}$, $y_2 = v$ [m/s]

$F = dy_{opt}/dd = [0.25 \quad -0.2]^T$

$H = [h_1 \quad h_2]$

HF = 0 $\rightarrow h_1 f_1 + h_2 f_2 = 0.25 h_1 - 0.2 h_2 = 0$

Choose $h_1 = 1 \rightarrow h_2 = 0.25/0.2 = 1.25$

Conclusion: **$c = hr + 1.25 v$**

Control **$c = \text{constant}$** \rightarrow hr increases when v decreases (OK uphill!)

With measurement noise

“Exact local method”

$$\min_H \| J_u^{1/2} (HG^y)^{-1} H [FW_d \quad W_{n,y}] \|^2$$

“=0” in nullspace method (no noise)

“Minimize” in Maximum gain rule (maximize $S_1, G, J_{-1/2}, G=HG^y$)

“Scaling” S_1

Analytical solution:

$H = G^y (Y^T Y)^{-1} Y$ where $Y = [F^T W_d \quad W_{n,y}]$

- No measurement error: HF=0 (nullspace method)
- With measurement error: Minimize $G^y c$
- Maximum gain rule

In practice: What variable $c=Hy$ should we control? (for self-optimizing control)

1. The optimal value of c should be insensitive to disturbances
 - Small HF = dc_{opt}/dd
2. c should be easy to measure and control
3. The value of c should be sensitive to the inputs (“maximum gain rule”)
 - Large $G = HG^y = dc/du$
 - Equivalent: Want flat optimum



Note: Must also find optimal setpoint for $c=CV_1$

Example: CO2 refrigeration cycle

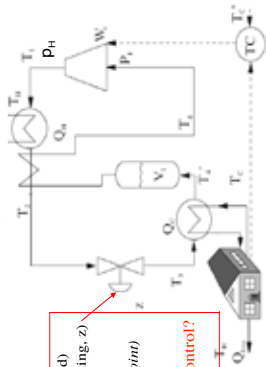

$J = W_s$ (work supplied)
 $DOF = u$ (valve opening, z)
 Main disturbances:
 $d_1 = T_{in}$
 $d_2 = T_{setpoint}$
 $d_3 = U_{loss}$

What should we control?

CO2 refrigeration cycle

- Step 1. One (remaining) degree of freedom ($u=z$)
- Step 2. Objective function. $J = W_s$ (compressor work)
- Step 3. Optimize operation for disturbances ($d_1=T_c, d_2=T_{in}, d_3=UA$)
 - Optimum always unconstrained
- Step 4. Implementation of optimal operation
 - No good single measurements (all give large losses):
 - P_1, T_1, z, \dots
 - Nullspace method: Need to combine $n_1+n_2=1+3=4$ measurements to have zero disturbance loss
 - Simpler: Try combining two measurements. Exact local method:
 - $c = h_1 P_1 + h_2 T_1 = P_1 + k T_1; k = -8.53 \text{ bar/K}$
 - Nonlinear evaluation of loss: OK!

CO2 cycle: Maximum gain rule

Linear "maximum gain" analysis of controlled variables for DOF case

Variable (y)	Disturbance	$\frac{\Delta y}{\Delta u}$	$\frac{\Delta y}{\Delta d}$	$\frac{\Delta y}{\Delta T_{in}}$	$\frac{\Delta y}{\Delta UA_{loss}}$	Spans n	$ \Delta y_{total} + n$	$\frac{\Delta y}{\Delta u}$ [CL]	$\frac{\Delta y}{\Delta d}$ [Subopt]
P_1 (bar)	T_{in}	0.12	-0.291	0.174	0.00015	1.0	0.177	0.25	0.25
T_1 (°C)	T_{in}	0.041	-0.085	0.054	0.00015	1.0	0.054	0.054	0.054
T_2 (°C)	T_{in}	0.041	-0.085	0.054	0.00015	1.0	0.054	0.054	0.054
T_3 (°C)	T_{in}	0.041	-0.085	0.054	0.00015	1.0	0.054	0.054	0.054
T_4 (°C)	T_{in}	0.041	-0.085	0.054	0.00015	1.0	0.054	0.054	0.054
T_5 (°C)	T_{in}	0.041	-0.085	0.054	0.00015	1.0	0.054	0.054	0.054
T_6 (°C)	T_{in}	0.041	-0.085	0.054	0.00015	1.0	0.054	0.054	0.054
T_7 (°C)	T_{in}	0.041	-0.085	0.054	0.00015	1.0	0.054	0.054	0.054
T_8 (°C)	T_{in}	0.041	-0.085	0.054	0.00015	1.0	0.054	0.054	0.054
T_9 (°C)	T_{in}	0.041	-0.085	0.054	0.00015	1.0	0.054	0.054	0.054
T_{10} (°C)	T_{in}	0.041	-0.085	0.054	0.00015	1.0	0.054	0.054	0.054
W_s (kW)	T_{in}	-4.55	-11.18	0.119	-0.119	0.44	0.425	16.55	16.55

Nullspace method: $c = P_1 P_1 + h_2 T_1 = P_1 + k T_1; k = -8.53 \text{ bar/K}$

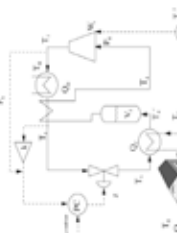

CV1= Room temperature
 CV2= "temperature-corrected high CO2 pressure"

Refrigeration cycle: Proposed control structure

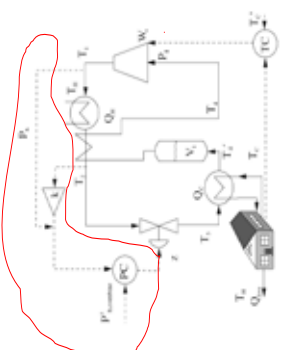

J.B. Jørgen, S. Mørstøl/Control Engineering (2018) 5(66-80)

NTNU

Step 4. Where set production rate?

- Where locate the **TPM** (throughput manipulator)?
 - The "gas pedal" of the process
- Very important!
- Determines structure of remaining inventory (level) control system
- Set production rate at (dynamic) bottleneck
- Link between **Top-down** and **Bottom-up** parts
- **NOTE: TPM location is a dynamic issue.**
Link to economics is to improve control of active constraints (reduce backoff)

34

Production rate set at inlet : Inventory control in direction of flow*

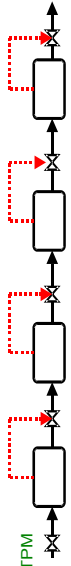

* Required to get "local-consistent" inventory control

NTNU

Production rate set at outlet: Inventory control opposite flow

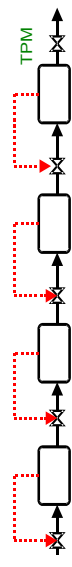

36

Production rate set inside process

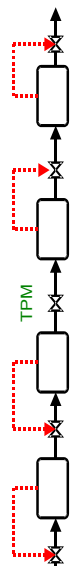

General: "Need radiating inventory control around TPM" (Georgakis)

QUIZ 1

CONSISTENT?

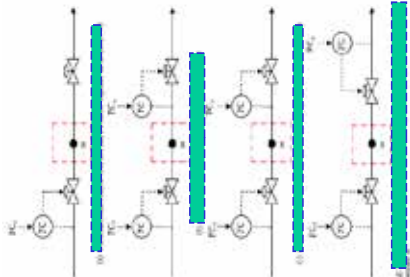

$$\text{Flow rate: } q = C_v f(z) \sqrt{\frac{\rho \Delta z}{\rho}} \quad |u^y|/s_i$$

Conclusion:
Systematic procedure for plantwide control

- **Start "top-down" with economics:**
 - Step 1: Define operational objectives and identify degrees of freedom
 - Step 2: Optimize steady-state operation.
 - Step 3A: Identify active constraints = primary CVs **c**.
 - Step 3B: Remaining unconstrained DOFs: Self-optimizing CVs **c**.
 - Step 4: Where to set the throughput (usually: feed)
- **Regulatory control I: Decide on how to move mass through the plant!**
 - Step 5A: Propose "local-consistent" inventory (level) control structure.
- **Regulatory control II: "Bottom-up" stabilization of the plant**
 - Pair variables to avoid interaction and saturation
- **Finally: make link between "top-down" and "bottom up".**
 - Step 6: Advanced/supervisory control system (MPC).
 - CVs: Active constraints = look after variables in layer below (e.g., avoid saturation)
 - MVs: Setpoints to regulatory control layer.
 - Coordinates within units and possibly between units

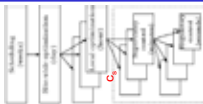

<http://www.nt.ntnu.no/users/skoge/plantwide>

Academic process control community fish pond

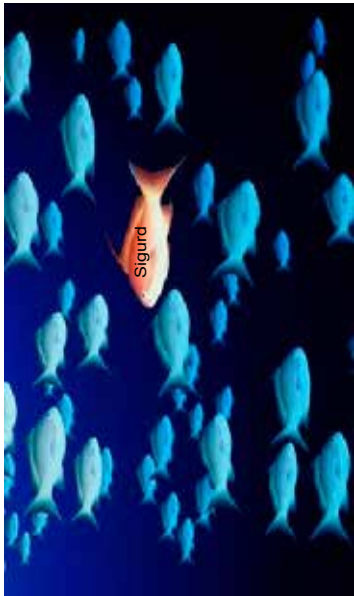

Optimal centralized solution (EMPC)

Summary and references

- The following paper summarizes the procedure:
 - S. Skogestad, "Control structure design for complete chemical plants", *Computers and Chemical Engineering*, **28** (1-2), 219-234 (2004).
- There are many approaches to plantwide control as discussed in the following review paper:
 - T. Larsson and S. Skogestad, "Plantwide control: A review and a new design procedure" *Modeling, Identification and Control*, **21**, 209-240 (2000).
 - S. Skogestad, "Economic plantwide control", Book chapter in V. Karwala and V.P. Rangaiah (Eds), *Plant-Wide Control: Recent Developments and Applications*, Wiley (2012).
- Another paper:
 - S. Skogestad "Plantwide control: the search for the self-optimizing control structure", *J. Proc. Control*, **10**, 487-507 (2000).
- More information:

<http://www.nt.ntnu.no/users/skoge/plantwide>

KRISTER FORSMAN

PERSTORP

Practical and theoretical aspects of plant wide control for chemical plants

We discuss some methods available for addressing various issues in plant-wide control, and exemplify them with concrete examples from chemical plants. Central concepts discussed are throughput manipulator selection, degrees of freedom and variable pairing, as well as analysis and selection of control structures. In connection with this we also address the question about control specifications, and the compromise between high level automation and ease of use.

Some concrete examples presented are flow split control, reactor control and inventory controls.



On PWC for chemical plants

Krister Forsman
2016-09-29



Outline

- Short facts about specialty chemicals industry and Perstorp
- Plantwide control:
 - Degrees of freedom
 - Throughput manipulator selection
- Specifying control objectives



K. Forsman, 2016-09-29, No. 2



Control: What differs between different industries?

- For mature processes, with a large installed base, there are standard solutions; often quite advanced. Often packaged by control system suppliers.
 - Oil refineries (~800 world wide)
 - Paper machines (2000)
- For specialized processes, that are fairly unique, local expertise has to design the controls.
 - Only a handful of plants in the whole world
 - Often confidential processes



K. Forsman, 2016-09-29, No. 4

Characteristics of typical specialty chemicals plants

- Synthesis (reaction) followed by a large number of separation steps.
- Reaction is often batch-wise, and separation continuous.
- Separation can be a number of sequential distillations, evaporations, crystallizations, filtrations, centrifuges, decanters, etc.
- High value side streams (byproducts); many recycle loops
 - The separation part of the plant is much more complex than the synthesis.
 - Complex topologies
 - Many internal buffers
- Plants operate 24/7
- Controlled by computerized control systems
- Products are liquid, solid or gas



K. Foreman, 2016-09-29, No. 5

Topology for plant with multiple separations

(Loosely based on a true story)

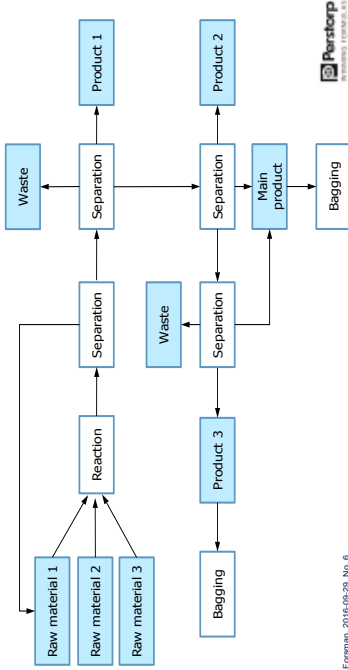

K. Foreman, 2016-09-29, No. 6

In reality, much more complicated



How many throughput manipulators?
 What is the production rate?
 What does "shutdown" mean ?

K. Foreman, 2016-09-29, No. 7

The Perstorp group – short facts

- Specialty chemicals company with focus on organic chemistry
 - Turnover 2015: ~1200 MEUR
 - Profit 2015: ~180 MEUR
 - Main owner: PAI Partners, a French equity company
 - 1500 employees
- Products: Mainly additives for other chemical industries
 - Additives in paints and coatings, plastic-processing and automotive industries
 - Thermoplastics, plasticizers, solvents, bleaching agents, etc
 but also end products like feed additives and bio-diesel.
- Global Technology has a group of 4-5 people working full time on process control and industrial IT.



K. Foreman, 2016-09-29, No. 8



Nine production sites

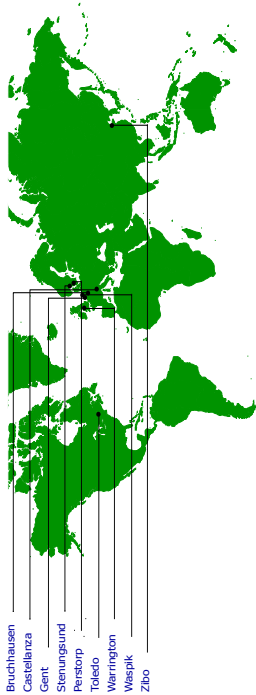

Totally ca 40 plants ~50 000 variables ~5 000 control loops

Catalytic incineration of VOC
 5 manipulated variables
 11 process variables
 What to control? How?

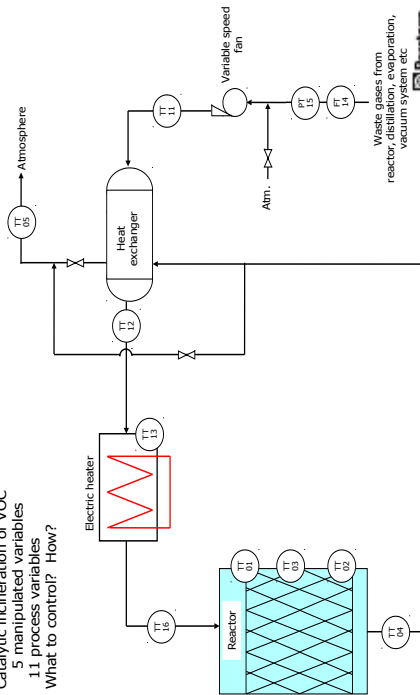

Degrees of freedom

DoF central concept in PWC

- Control engineering point of view: Number of independent manipulated variables
 - Typically: number of valves. Causality important.
- Chemical engineering point of view: Number of independent variables in steady state
- The number of controlled variables = number of DoF
- Differ between dynamic and static DoF
 - Inventories have to be controlled. Each one consumes a dynamic DoF.
 - The remaining ones quantify the static behavior of the process.
- Most expositions lack a rigorous mathematical definition.
 - This should be possible using algebraic concepts, such as transcendence degree of extension fields.

Different competencies for different levels in the structure

- Closing a loop does not reduce the #DoF. We have to choose setpoint.
- Moving DOFs upwards in the hierarchy requires several competencies.

Example 1

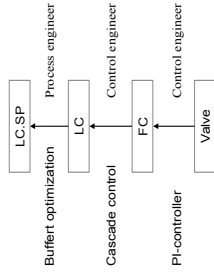

Example 2

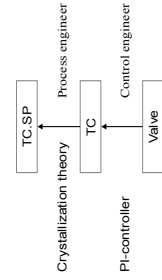

Aspects of Plant wide control



The throughput manipulator

Throughput manipulator determines production rate

- A plant always has a variable that determines the throughput rate:
 - It is normally a flow, the "master flow". The "gas pedal"
 - Called TPM = throughput manipulator
 - If you have very large buffers between process areas, where level is not controlled, you may in fact have several TPMs.
- The operator gives the setpoint for the TPM.
- All other flows are given indirectly by the master flow, typically through level controls.
- You have to select a variable that is TPM; the choice is either deliberate or inadvertent.

Choice of TPM: Bottle neck or minimum variation

- The two most common ways of selecting which variable is TPM:
 - The flow closest to the **bottle neck**
 - The flow most important to **keep constant**.
- Reason: The TPM flow will be the "most constant" one.
- If no thought is given to the choice, then often the first flow in the plant becomes TPM.

Unconsidered choice of TPM gives suboptimal operation

- Example: In a plant the feed of reactant 1 was chosen as TPM.
- The filtration step is the bottle neck.
- Which variable should be master flow in order to give maximum production with minimum number of SP changes?

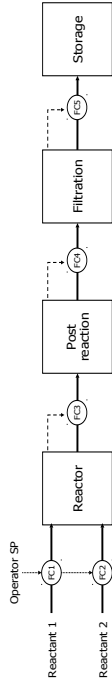

Inventory controls; real example

- Four tanks in series. One throughput manipulator (TPM). Level controllers.
- The “radiating rule” gives the control topology below.

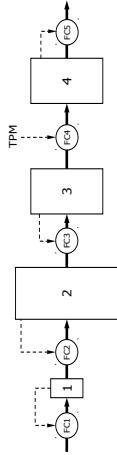

Solution: Filter feed = TPM

- The setpoint for the filter feed flow is set by operator / plant manager.
- Other flows are a consequence of level controls or similar.

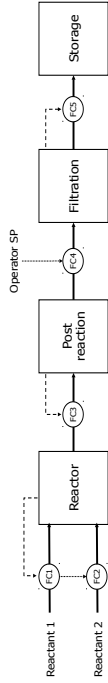

Radiating rule is not mandatory

- The topology below will also work.
 - Easy to realize that the entire process can be stabilized using only PI controllers.
- Disadvantage: LC2 won't work if LC1 is in manual.
- However, it has an advantage too...

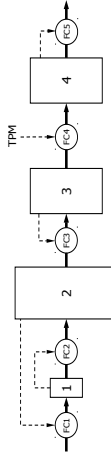

FC1 sometimes fixed

- At times, the operator needs to run flow 1 with fixed SP.
- Since tank 1 is much smaller than tank 2, it is easier to handle the process if level 1 is still controlled automatically, and FC1 is used to manually control level 2.

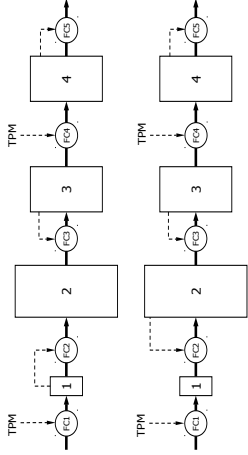

K. Foreman, 2016-09-29, No. 21

This can be made to work too...

- ...meaning all levels can be stabilized using only PI-controllers.

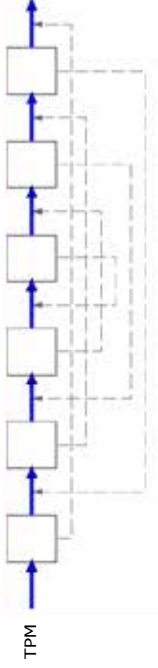

K. Foreman, 2016-09-29, No. 22

Even this "works"

- But not if both LCs are PI-ctrl. One has to be a PID.
- Maybe this can be made into a general indicator?
 - If you can't stabilize the plant without resorting to using derivative action, the structure is not "good".

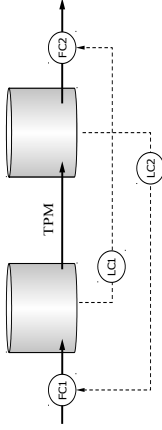

K. Foreman, 2016-09-29, No. 23

TPM selection and consistency

- How many of the flows can be set independently?
- Which combinations of flows?

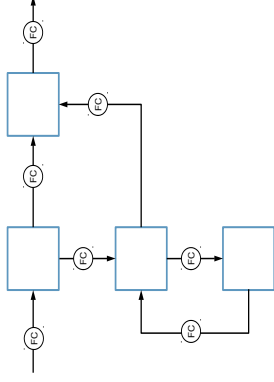

K. Foreman, 2016-09-29, No. 24

This works

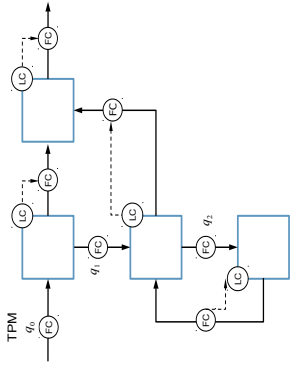

This is inconsistent

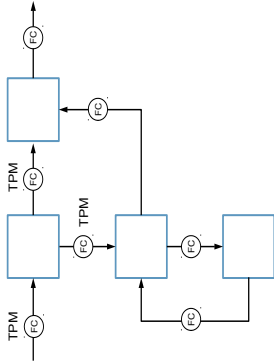

This is also inconsistent

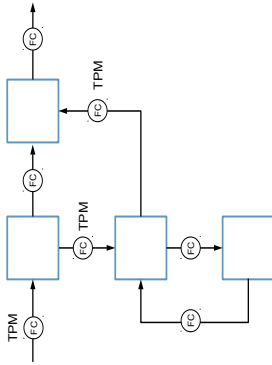

Algorithm for finding all consistent schemes

Let x be the incidence matrix of the graph representing the topology.
 Suppose we assign the flows k_1, \dots, k_n to be TPMs.

This choice is consistent iff the matrix obtained by removing columns k_1, \dots, k_n from x has maximum rank.

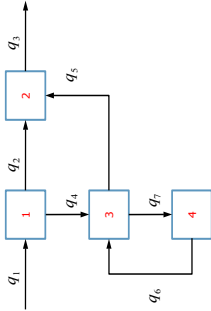

$$\begin{aligned}
 & \begin{bmatrix} 0 & 1 & 0 & 0 & -1 & 0 & 0 & 0 \\ 0 & 0 & 1 & -1 & 0 & 1 & 0 & 0 \\ 0 & 0 & 0 & 0 & 1 & -1 & 1 & -1 \\ 0 & 0 & 0 & 0 & 0 & 0 & -1 & 1 \end{bmatrix} \\
 & x = \begin{bmatrix} 0 & 1 & 0 & 0 & -1 & 0 & 0 & 0 \\ 0 & 0 & 1 & -1 & 0 & 1 & 0 & 0 \\ 0 & 0 & 0 & 0 & 1 & -1 & 1 & -1 \\ 0 & 0 & 0 & 0 & 0 & 0 & -1 & 1 \end{bmatrix}
 \end{aligned}$$

Most plants have several TPMs

- This is possible because there are intermediate buffers inside the plant.
- An indicator of this is that there is a large number of setpoint changes for some of the flows.
 - Visible e.g. in operator action statistics.
- Why not have a completely automated plant where buffer levels are controlled automatically (by P-controllers)?
 - “Bullwhip” effect
 - Difficult to foresee all possible scenarios

K. Foreman, 2016-09-29, No. 29



PWC issues should be included in control projects

- The plant-wide control strategy is a very important tool for making a plant operate efficiently.
 - Degrees-of-freedom analysis for enumerating all possible PWC schemes
 - Thruput manipulator selection
- Unfortunately PWC is often not taught in courses.
 - Somehow falls between chemical engineering and control theory.
- Process engineers rarely use a systematic approach to choose PWC strategy.
- But “PWC thinking” should be a part of all investment projects and control projects.

K. Foreman, 2016-09-29, No. 31



An overlooked issue in TPM selection

- The choice of TPM affects the precision in production planning:
 - If the TPM is located far away from the point where production is measured, it becomes more difficult to adhere to the production plan.
 - Plant management / operator has to guess what “speed” to choose in order to produce the right number of tons.

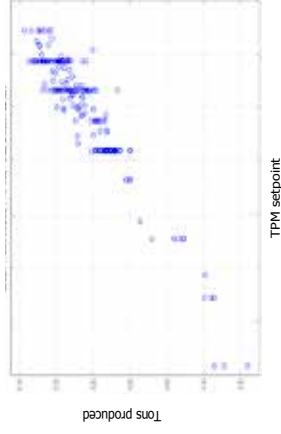

K. Foreman, 2016-09-29, No. 30



Control specifications

K. Foreman, 2016-09-29, No. 32



Specifying control objectives

- Examples of control specifications are
 - Keep the PV as close as possible to the setpoint when there are disturbances, while not moving the MV too much.
 - The controller should be possible to run in Auto during startups.
 - Minimize outlet flow variations while keeping the level within some limits.
 - Maximize reactor throughput while keeping temperature within limits.
- It is often hard to obtain a scientific description of the control objectives.
 - There may be implicit requirements.
- Control engineers don't always have a deep understanding of the process.
- Process engineers are normally not used to specifying control objectives.
 - What are constraints and what is target function?

Simple solution: ratio control

- Traditional ratio control (below) lets the operator specify flow 3 as a factor of flow 2. PV2 is fixed (but not closed).
 - This solution was not accepted by operational staff.
 - They sometimes have to set flow 2 as a factor of flow 3.
 - Total pressure drop should be as small as possible
 - Which structure can we use now?

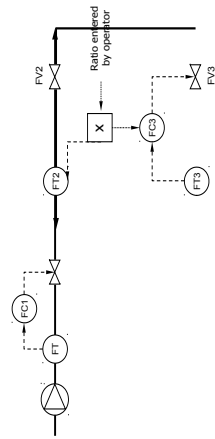

Example: Split flow

- Liquid (incompressible) flow. The total flow is controlled by FC1.
 - Introduce a way to split the flow between stream 1 and stream 2.
 - Of course, controlling both flow 2 and flow 3 is impossible.

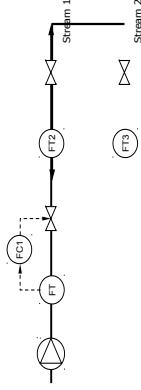

This solves the split control problem

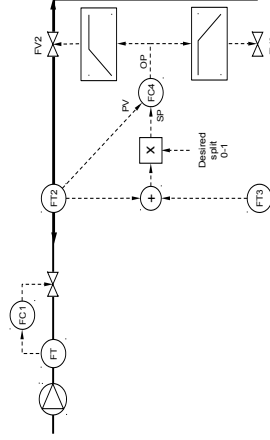

Desired split FT2/Total is entered by the operator

Some things should be left to the operators

- Complex control solutions make it hard for the operator to know which situations are handled automatically.
- Sometimes the control solution does not cover all the scenarios that the operator has to handle.
 - Some requirements were forgotten in the specifications.
- More automation may increase the cognitive load on the operator.
- Compare: Adaptive cruise control



K. Foreman, 2016-09-29, No. 37

K. Foreman, 2016-09-29, No. 38

Thank you!

DON CLARK

SCHNEIDER ELECTRIC

The IoT of Automation - A Totally New Way to Look at Control and Automation in the Process Industries

The future of process automation technology as we know it is slowly disappearing. The challenges of process control – to keep a process safe and operating to design to produce economic value for the asset owners – will always persist and will never go away. But, how we solve/address those challenges – i.e. the platform on which the control is executed, ie the “automation” – will radically change in the future. The forces of economics and evolving technology are pushing automation relentlessly toward a future of highly intelligent autonomous cyber physical systems (CPS), networked in a manner that enables their interaction and interoperability and maintains absolute security. This concept is called the Industrial Internet of Things (IIoT). This paper will explore what “IIoT” will mean for process control and the automation industry, where the “intelligence” to achieve this objective is being pushed further and further down the architecture, and the traditional process control “Levels” (Levels 0 to 6 of the Purdue Reference Model) are being compressed over time closer to the valve and the sensor, and ultimately into the process assets themselves, and “Levels” will no longer mean “networks”, but rather describe functionality.



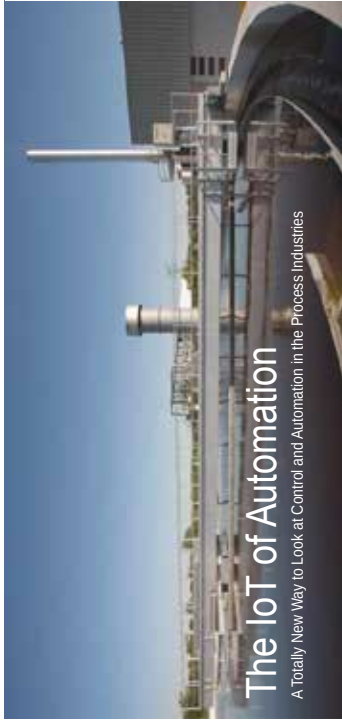

The IoT of Automation

A Totally New Way to Look at Control and Automation in the Process Industries

Presented by: Donald C. Clark
 VP Industries and Schneider Master Expert Edison Fellow
 Process Automation Business

LCCP Process Control Workshop, September 28-30, 2016
 Lund University, Lund, Sweden

Life is On | **Schneider**
ELECTRIC

Introduction

- *Process control*: to keep a process safe and operating to design to produce economic value for the asset owners....
 - ...has been with us since the earliest days of the industrial revolution....and...
 - ...will always persist....and will never go away.
 - *How we solve/address* those challenges – the platform on which the control is executed – is the “*automation*” ...
 - ...has changed over time....and will radically change in the future.
 - The “intelligence” to achieve this objective is being pushed further and further “down” the architecture, and the traditional process control “Levels” are being compressed over time closer to the valve and the sensor....and to the process itself.
 - There will ALWAYS be the conversion process itself....and its process equipment: pipes, vessels, pumps, reactors, concrete, steel, catalysts, etc., but how to control that process has – and will continue – to dramatically shift over time.
- Life is On | **Schneider**
ELECTRIC



“A Control System Without Field Devices is Nothing But a Brain in a Jar...”

This is how we now tend to think of modern industrial control systems...
 We've forgotten about the field....
*Measurement is no longer mentioned in polite circles...
 “...what's a valve?”*
 We've even forgotten about control....
 “They're just a computer...
 “...just like any other computer...”

Life is On | **Schneider**
ELECTRIC

When it comes to process control and automation, how should we approach “IoT”?

State-of-the-Art Industrial Control System – for Four Decades

The predicament we're in:

2. Were severely limited in their scope by the technologies available:
 - a) Manual/direct human manipulation/intervention in the process
 - b) Mechanical control (e.g. spinning ball governors, siphon level control)
 - c) Pneumatic (huge benefit: *intrinsicly safe*)
 - d) Electronic
 - e) Digital computing and microprocessors
3. Forced control to be applied on the process, as an add-on or an appendage to the process
4. New technologies will bring the ability to shift that century-old paradigm so that control will be performed in the process, *in-situ*, in the actual process devices and equipment needed for the process, not “stuck-on”.
5. It will become embedded and autonomous in a way to mimic what in fact occurs in the control of biological processes such as the human body: *the process controls itself, it is NOT “stuck-on”.*

The Common Core Functionality (CCF)

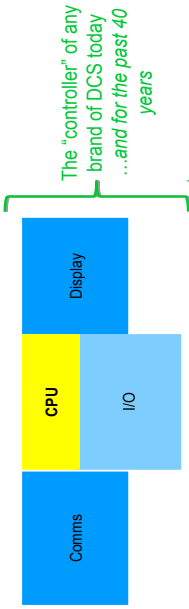

Has been utilized for decades to architect control systems
The economies of scale and time/technology curves has put us in the predicament we're in

"...it's just a computer..."



But: Available Technology Can Now...

- ...put this on a chip...
- ...for about \$3...
- ...to do about 8 things

Performs "a few" Control Instrumented Functions (CIF)

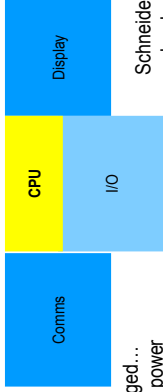

- ...very rugged...
 - ...very low power
 - ...harvest power needed
 - ...the size of a postage stamp
- Schneider is already developing this!

Empowers a totally new way to look at control
Allows us to return to our roots...



Imagine Instead...

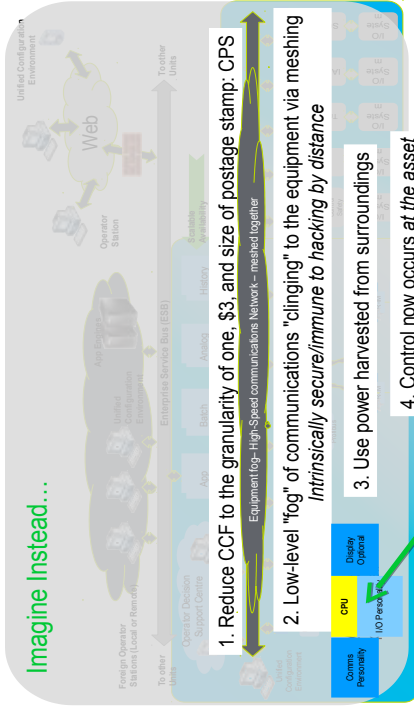

"Cyber Physical System" (CPS)



Traditional
 process sensing
 and outputs are "stuck
 on" to the process...

...and traditionally
 unmeasured devices...
 that are an integral
 part of the process...

...that are mini-processes in themselves...

...are usually treated as stupid (because they are), or just ignored...

And the controllers are even further removed from the process in the MCC

Today, the hierarchical equipment relationships that form the process must be implemented – and maintained – by people. That model is constructed for the system, not by the system

Now in a Plant Today...
 ● = traditional process sensors & outputs/values
 ● = process equipment, e.g. pumps, reactors, etc.



How Control at the Asset Will Change This...

For Traditional Process Sensing and Outputs...

Put measurement/control/comms CCF inside conventional sensors & valves...
 ...communicating via the secure highly localized communications fog

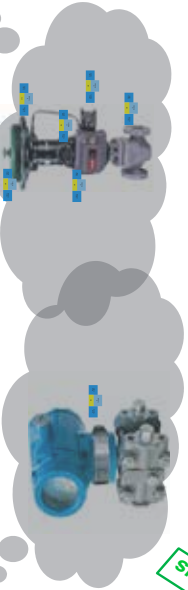

Autonomous

...handling routine process control – most usually with nearest neighbors
 ...as well as asset performance management – avatars

...aware of environment – self configuring (ie modeling). No need to keep models



As defined by the device vendor

So Now Our Plant Looks Like...

- With a control granularity approaching one
- Totally and truly “distributed control”
- Self identifying and autonomous to reduce configuration and modeling costs
- Built-in security
- Fail-safe robustness and redundancy only where needed
- Provides unprecedented scalability
- “Control” is sold with the equipment itself, not “stuck-on”
- Provides inherent asset performance intelligence

The “internet of Things” as it applies to automation

that “clings” to the process equipment only



The Same Can Be Done For Traditionally Unmeasured Devices...and Equipment

Put measurement/control/comms CCF inside the asset...
 ... communicating via the intrinsically secure highly localized fog of communications

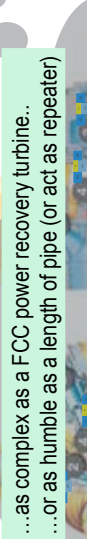

...as complex as a FCC power recovery turbine...
 ...or as humble as a length of pipe (or act as repeater)

...empowering equipment at the very edge of the process
 ...with the vendor’s IP – they know their equipment the best

Autonomous

...handling routine process control – most usually with nearest neighbors
 ...as well as asset performance management – avatars

...aware of environment – self configuring (ie modeling). No need to keep models



As defined by the equipment vendor

Immediate Benefits

- Allows for lower cost, and much more resilient and robust control as it is so close to the process, not removed/separated from it.
- Redundancy granularity of one within control clusters
- Self-identifying and autonomous - minimizing/eliminating configuration and modeling at control level. Any change is automatically accommodated.
- Low power – can use power harvesting for needed power
- Minimal/no wiring, intrinsically cyber-secure networks that follows the process
- Equipment vendors impart their asset performance knowledge within device:
 - First-level process control
 - Asset control of the process devices and equipment themselves
 - Asset performance of the process will become the norm and routine



Commercial Strategy ...

- Schneider's focus remains at the *systems level*
- Begin at the measurement and valve levels:

- Add **System software is key to this:**

- Valves • Devices are not stand-alone; are part of a system
- Reliant on open, interoperable industry Standards (ISA95, OG):
 - Functionality/naming definitions
 - Communications
- Create a "system of systems"
- Each CPS has a bit of "system": build the system CPS by CPS

CPS's

- Current architectures can accommodate this technology allowing for systems to be a combination of current and this technology
- Move from *process efficiency control* to *business performance control*
- Traditional "advanced" functionality operating over a wide-range of assets will still be provided at the system level communicating over the fog

Life Is On

Schneider Electric

Summary

- Essentially takes conventional automation systems, chops it up to smallest granularity possible, and distributes around the process in the actual process devices and equipment, all powered by harvested power, communicating in a fog of combined meshes, operating within a *unifying systems framework*
- Control is no longer "stuck on" — it is *in situ*, autonomous, part of the process
- Control shifts to the device itself with added device IP by vendor
- The plant models itself: control perfectly represents the actual plant
- Schneider focuses on what it does best: providing the *system characteristics*
- Maximum security, reliability and resiliency at lowest possible cost
- This is the *Internet of Things* as applied to industrial process control:

It is functionality, not connectivity Life Is On

Schneider Electric

Tack

Life Is On

Schneider Electric

DENNIS BRANDL

BR&L CONSULTING

The Future Control System Environment, as envisioned by the ExxonMobil Next Generation Control System Pilot Project

There has been a lot of discussion about the ExxonMobil Next Generation Control System initiative. This session will help to clear the air and explain the positive and negative consequences of changing the existing DCS and PLC architectures by one of the participants in the initiative. The current architectures have not changed significantly since the 1970's. They are still based on the concept of one or more computers in a hardened box, what connects to tens to thousands of I/O points, connected to dumb devices. There have been incremental advances in functionality, and decreases in size and cost, but the basic architecture has remained the same. The advances that are shaking up the world through connected smart devices in homes, stores, health care, transportation, and energy have not penetrated the barrier of obsolete industrial system architectures. The ExxonMobil initiative was designed to break down the barrier and fix the major limitations of the DCS and PLC architectures. The new architecture, its pros and cons will be discussed.



The Future Control System, Environment,

As envisioned by the a member of the ExxonMobil Next Generation Control System Pilot

Dennis Brandl
Principle Consultant, BR&L Consulting
dnbrandl@briconsulting.com

2016 © BR&L Consulting Inc.
September 28, 2016
LCCC Process Control Workshop 2

Abstract -

The LCCC Process Control Workshop
September 28-30, 2016, Lund University Sweden

- ▶ There has been a lot of media discussion about the ExxonMobil Next Generation Control System initiative
- ▶ It's not common for a large company to say to industry something like:

'We don't like what you are selling us, we want better, not just incrementally better, but a whole lot better.'
- ▶ This session will help to clear the air and explain the positive and negative consequences of changing existing DCS and PLC architectures

2016 © BR&L Consulting Inc.
September 28, 2016
LCCC Process Control Workshop

3

Why Now?

- ▶ The current architectures have not changed significantly since the 1980's.
 - ▶ They are still based on the concept of one or more computers in a hardened box, what connects to tens to thousands of I/O points, connected to dumb devices.
- ▶ There have been incremental advances in functionality, and decreases in size and cost, but the basic architecture has remained the same.
- ▶ The advances that are shaking up the world through connected smart devices in homes, stores, health care, transportation, and energy have not penetrated the barrier of obsolete industrial system architectures.

2016 © BR&L Consulting Inc.
September 28, 2016
LCCC Process Control Workshop

What is Possible Today

- ▶ Raspberry Pi, Android MK808B, Adrenio, SmartTILE ...
- ▶ Massive computing systems, in tiny inexpensive boxes
 - ▶ Dual Core Cortex-A9, Android 4.2 Jelly Bean With Bluetooth, HDMI, 1GB RAM, 8GB ROM, 3.4" x 1.1" x 0.5 inches and 1.3 ounces, - \$43.99
 - ▶ 700MHz ARM processor with FPU and Videcore, 4 GPU (24GFLOPs) HDMI, 10/100 BaseT, 512MB BaseT, 3.4" x 2.2" x 0.8 inches, - \$27.98
- ▶ 32 Bit CPU, 256 DIOs 12 AIOs, High level language programming, Ethernet built in, 2.6" x 2.5" x 0.95" --\$100.00

	Circa 1980's	Today	Change
Memory	1 Mega Byte	1,000 Mega Byte	1,000X
CPU	1 MIP	10,000 MIPs	10,000X
Network	1 MB	1,000 MB	1,000X
Size	40 ft ³	0.04 ft ³	1,000X
Cost	\$1,000,000	< \$100	1,000 X

2016 © BR&L Consulting Inc.
September 28, 2016
LCCC Process Control Workshop

Monolithic Proprietary Systems If it ain't broke ...

- ▶ Today's monolithic, single-vendor control systems boast an impressive 99.999+% system availability
- ▶ What design characteristics have contributed to this impressive reliability performance?
 - ▶ Simple, deterministic system functionality (e.g. proprietary function block and custom programming etc.)
 - ▶ Physical coupling of a field I/O sub-network to one and only one controller creating a self-contained regulatory control appliance
- ▶ Single system designer and integrator
 - ▶ Issues a standard product release and ensures compatibility
 - ▶ Provides a single point of contact for all system performance issues; no opportunity to "pass the buck."
- ▶ Early proprietary control systems comprised entirely of running proprietary operating systems connected via proprietary networks offered some level of "security through obscurity"

LOCC Process Control Workshop

September 28, 2016

6

LOCC Process Control Workshop

September 28, 2016

© 2016 by BSM Consulting Inc.

Well It Is Broke, In Several Ways

- ▶ The architecture complicates and constrains growth
 - ▶ An I/O sub-network is normally physically connected to one and only one controller so any new application using that I/O must fit into the single connected controller
 - ▶ If the controller becomes loaded, I/O and associated applications may have to be moved to another controller
 - ▶ If the I/O sub-network becomes loaded, adding I/O requires a new controller, even if the existing controller has spare capacity
 - ▶ You are limited to whatever control programming language and built-in capabilities provided by the vendor
 - ▶ No "Best of Breed" solutions allowed, or they are very expensive

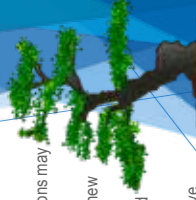

Limited Growth Potential

© 2016 by BSM Consulting Inc.

Well It Is Broke, In Several Ways

- ▶ Controllers cannot be upgraded to exploit new & more sophisticated functionality due to the cost and risk associated with replacement
 - ▶ Stagnant controller capability do not allow facilities to exploit the competitive advantage derived from new technologies
- ▶ Migrating hierarchical systems usually requires concurrent controllers and I/O replacement driving up project cost, complexity, duration and risk
 - ▶ The result is that few replacements are done, and systems are decades old

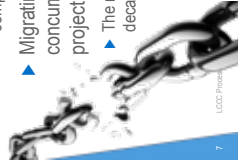

LOCC Process

September 28, 2016

7

LOCC Process Control Workshop

September 28, 2016

© 2016 by BSM Consulting Inc.

There is More to Control than PID Loops

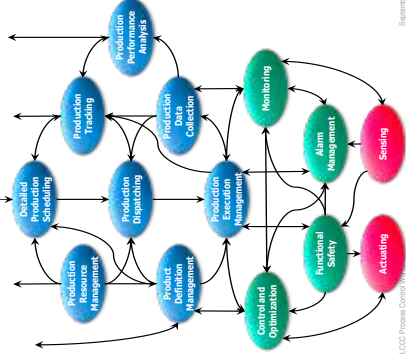

September 28, 2016

LOCC Process Control Workshop

There is More to Control than PID Loops

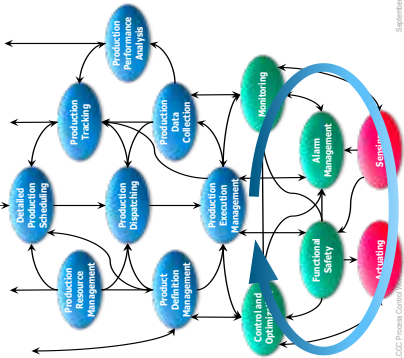

September 25, 2016

LOCCP Process Control

There is More to Control than PID Loops

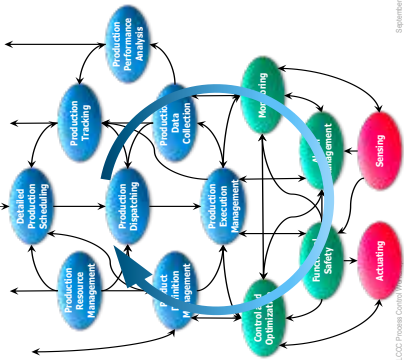

September 25, 2016

LOCCP Process Control

There is More to Control than PID Loops

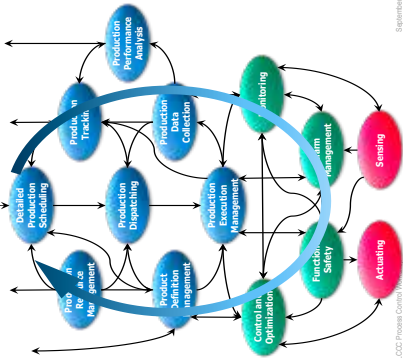

September 25, 2016

LOCCP Process Control

There is More to Control than PID Loops

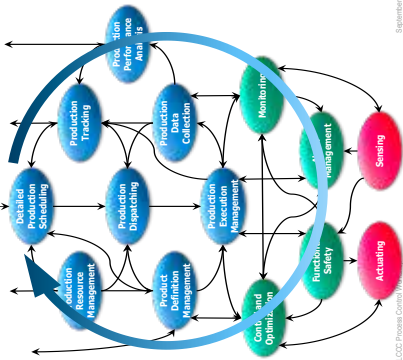

September 25, 2016

LOCCP Process Control

- There is "control" everywhere
- The next big gains will come not at the PID level, but through control and optimization of the higher level activities

New Architecture, Functional Characteristics

- ▶ A system which does not require replacement of existing instruments.
- ▶ A system which is adaptable to future changes without requiring wholesale replacement.
- ▶ Inherent security that is designed and built-in, not bolted on after the fact.
- ▶ The preservation of intellectual property in the form of control strategies, configurations, representations, and reports, with online replacement of system components over a very long 20-40 year period.
- ▶ A system designed to improve operational situation awareness enabling broader scope of control and better automated response to normal situations.
- ▶ A system that is not limited to the control capability provided by the vendor's supplied function blocks and gives the Owner the freedom to use best-of-breed components at all levels of the control strategy hierarchy when it is justified.

LOCC Process Control Workshop
September 28, 2016

September 28, 2016

14

LOCC Process Control Workshop

Automation Industry Challenges The "want" list

- ▶ A flexible, modular, scalable and extendable system architecture
- ▶ Conformant with existing field device standards and communication protocols
- ▶ The flexibility to assign any I/O to any networked device
- ▶ Simple, online addition/replacement of any networked device as a maintenance activity
- ▶ Distributed, portable and interoperable automation
- ▶ Ability to execute an application on all compliant platforms (portability)
- ▶ Deployment of interactive applications on different platforms with no modification (interoperability)
- ▶ Standard exchange of both structure and unstructured data between adjacent system levels
- ▶ Intrinsic Security
 - ▶ Embedded security layers that can evolve with emerging threats
 - ▶ Verification of message authenticity and integrity, with a simple key management system
 - ▶ Authentication of new network devices
 - ▶ Authentication of all new executable code
 - ▶ Advanced intrusion detection & prevention
- ▶ Productivity Improvements
 - ▶ Plug-and-play, field device technologies
 - ▶ Intrinsic system notification tools (e.g. alarms, alerts, advisories, etc.)
 - ▶ Lower the costs associated with patch management, software updates, etc.

September 28, 2016

2016 © BSM Consulting Inc.



Federated Automation Logic Control on Open Network Systems

A New Model for Control Systems

15

LOCC Process Control Workshop

September 28, 2016

18

LOCC Process Control Workshop

The New Architecture DCN – Distributed Control Nodes

- ▶ DCN is a single-channel I/O module that support both real-time application processing and interfaces with other network protocols
- ▶ A system is a collection of DCNs with I/O and without I/O, a DCN-cloud
- ▶ A DCN-cloud for centralized applications ranging from high-end data-center host servers to redundant embedded computers hardened for harsh field environments
- ▶ A high-speed IP-based Ethernet (wired or wireless) switch fabric that support layer 3 switching, VLANs and QoS to allow for the greatest network flexibility and segmentation

September 28, 2016

2016 © BSM Consulting Inc.

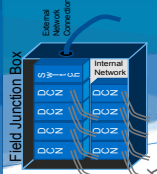

DCN-Cloud Smart I/O ++

- ▶ Ethernet connected
- ▶ So, lots of CPU power and memory
- ▶ Universal I/O
- ▶ Even the smallest, single point device will have at least:
 - ▶ 2 GHz multi-core processor
 - ▶ 1 GB of memory
 - ▶ 10 MByte, 100 MByte, 1 GByte, 10 GByte wireless & wired network support
 - ▶ Multiple protocol support
 - ▶ Real time Virtual Machine (VM) O/S
 - ▶ Think of a single point device with the power, memory, O/S, and network capability of a small cell phone
- ▶ This capability on every device:
 - ▶ I/O Point, or limit switch, proximity switch, motor, pump, valve, ...

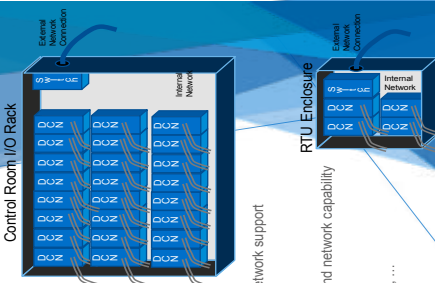

Distributed & Non-Distributed Control in the DCN-cloud

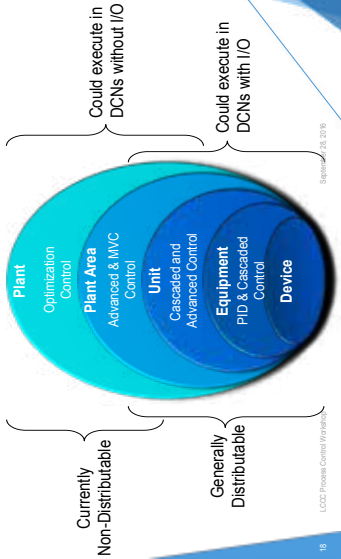

Distributed & Non-Distributed Control in the DCN-cloud

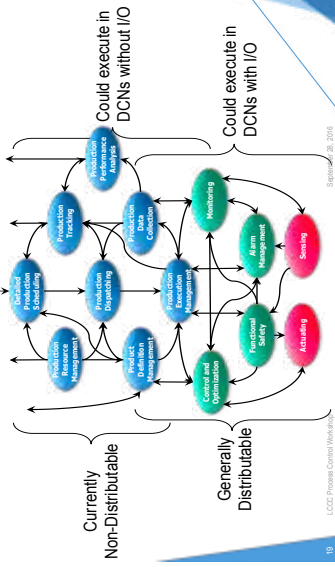

An Example Of A Distributed Algorithm

- ▶ Why must you program the communication layout?
- ▶ Let the "system" take care of it.
- ▶ "Control" functionality is cheap & small !
 - ▶ Compared to the computing power used for high speed communication
- ▶ Scope of failures can be minimized, down to a single loop
- ▶ Redundancy can be selected on as "as needed" basis

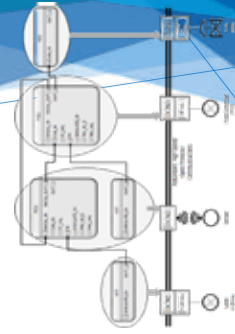

Networks Aren't Fast Enough! WRONG!

- ▶ Managed switches and high speed networks are today's "active backplanes"
 - ▶ As fast as previous backplanes
 - ▶ As resilient (with fail silent semiconductor logic)
 - ▶ A whole lot more extensible
 - ▶ A whole lot more open
- ▶ Switching Hub Technology
- ▶ Redundant Managed Gigabit Switches
- ▶ Message Authentication
- ▶ Class of service message priority
- ▶ Predefined message time slots



Whenever they say it can't be done, remind them that they make a jellybean that tastes exactly like popcorn.

Why The DCN Approach

- ▶ Conformant with existing field device standards and communication protocols
- ▶ The flexibility to assign any I/O to any networked device
- ▶ Modular online addition/replacement of any networked device as a maintenance activity
- ▶ Why
 - ▶ A modular system allows paced, online, component-by-component migration towards any new platform whether driven by obsolescence, strategic or economic considerations
 - ▶ Coupled, online controller and I/O replacement projects are expensive, lengthy and risky
 - ▶ Purchasing only the I/O and control capacity one needs avoids pre-investment in large amounts of spare capacity and lowers the cost hurdle associated with new investment.
 - ▶ Single channel I/O reduces the need for costly and complex redundancy schemes

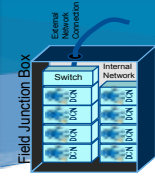

DCN Within a Device Secure Cyber Physical Device

- ▶ Distributed
 - ▶ Can participate in distributed information management
- ▶ Industrial
 - ▶ Follows the industrial standards for safety, security, control, device management, communication protocols, ...
- ▶ Control-enabled
- ▶ Able to participate in distributed control strategies at all levels in the I/O or in every Device
- ▶ Part of, or attached to, every device in your manufacturing facility, production line, warehouse, refinery, chemical plant, ...
 - ▶ Limit switches, motor, pumps, valves, proximity switches, actuators, level sensors, robots, conveyor sections, vision systems, ...
- ▶ Secure by Design
- ▶ Self Maintenance Enabled

Smart Assets Auto-configured

- ▶ Every device is configured based on the role it performs in the control strategy
- ▶ Picks up its configuration from neighbors on startup
- ▶ Send configuration to neighbor on their startup
- ▶ Can run a "fault mode" simulation of a failed neighbor
- ▶ No extensive manual configuration, just specify the "role" the DCN is to assume, which could even come from a smart attached device

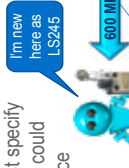

What it Will Take

- ▶ One more turn of Moore's law (18 months) to get the cost affordable
- ▶ Combining already existing different technologies into a system
 - ▶ The first PC was a system, combining existing technologies to create enormous new capabilities
 - ▶ The first smart phone was a system, combining existing technologies to create new markets and possibilities
 - ▶ Truly distributed control can combine existing technologies to provide systems that can grow organically in scale and in functionality
- ▶ To build it, you first have to dream it

29

LOCCP Process Control Workshop

September 28, 2016

© 2016 by BSA, Consulting Inc.

30

Assertion

"a confident and forceful statement of fact or belief"

- ▶ We have the opportunity for a quantum change in capability, functionality, usability, extensibility and reliability in control systems
- ▶ The old way of doing things won't get us where we need to go
- ▶ The new realities of computing power, networks, and Human Engineered HMI's give us the capability to improve production in ways we can not yet imagine!
- ▶ It's up to you to help create and use this new capability

LOCCP Process Control Workshop

September 28, 2016

© 2016 by BSA, Consulting Inc.

Questions & Discussions

31

September 28, 2016

© 2016 by BSA, Consulting Inc.

MARGRET BAUER

UNIVERSITY OF WITWATERSRAND

Dark data? The use of sensor data in process monitoring and control

Dark Data is a term for underused information that is collected, processed and stored and usually incurs more expense than value. Industrial manufacturing plants are prime suspects for gathering dark data. Many different sensors capture measurements, which is primarily stored in the plant information management system (PIMS). However, analysing the stored data systematically is a difficult task. Examples of making use of dark data are control loop performance monitoring, root cause analysis, sensor validation, predictive maintenance, alarm management and energy management. Increased processing power and big data analytics are opening new opportunities but rely on organised data capture. This talk discusses what methods and technology are currently available to get value out of dark data and shows the limitations of these approaches. It builds on the presenter's experience at ABB Corporate Research and presents current software solutions and developments.



Dark data: The use of sensor data in process monitoring and control

LCCC Process Control Workshop
September 28-30, 2016

Margret Bauer

School of Electrical and Information Engineering
University of the Witwatersrand
South Africa



UNIVERSITY OF THE
WITWATERSRAND
JOHANNESBURG

What is Dark Data?



Dark Matter

Unidentified type of matter that has not been observed yet, and does not give off or reflect light.

```
100101010100001011110101010101010101010101010101010101
0101011011101010010101010001010111110101
1000001111101010101110101010101110100011101
1010101010101010101010101110101010101010101010101000010
```

Dark Data

Information assets organizations collect, process and store during regular business activities, but generally fail to use for other purposes.

<http://www.gartner.com/it-glossary/dark-data/>



Wits



- One of the **oldest** Universities in South Africa, founded in 1896
- Rooted in the **mining** industry
- **Most famous student:** Nelson Mandela
- **Famous control engineers:** David Limebeer (Oxford), David Mayne (Imperial College), Anthony Bloch (University of Michigan)

Some sources that generate data in an industrial process

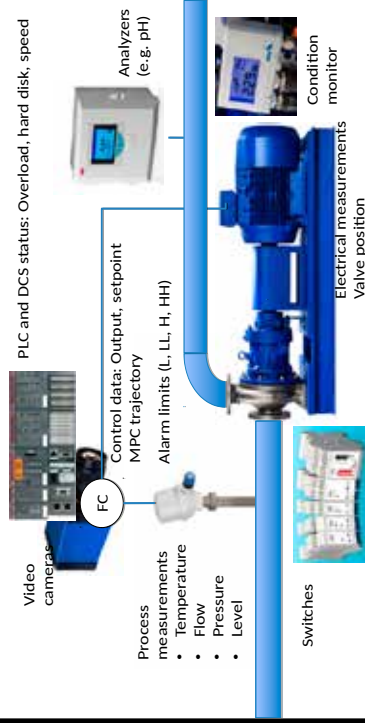

What happens to the process measurement data?

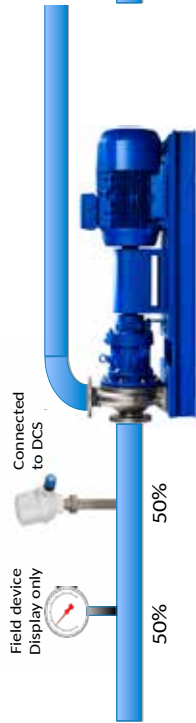

What happens to the process measurement data?

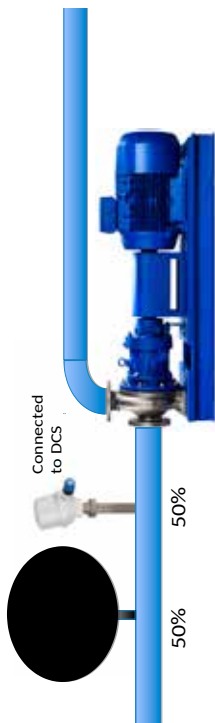

What happens to the process measurement data?



What happens to the process measurement data?

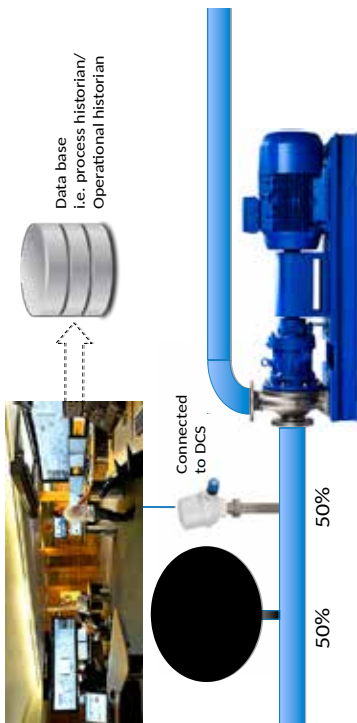

What happens to the process measurement data?

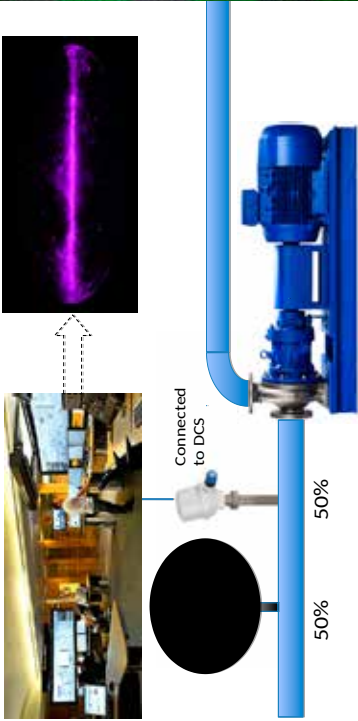

Wikipedia: Big data is a term for data sets that are so large or complex that traditional data processing applications are inadequate. Volume, Variety, Velocity, Veracity (Uncertainty)

"Before the term Big Data was being used as part of the Internet of Things, plant historians were handling large volumes of time-synchronized data."
B. Lydon, ISA Intech Magazine Jan/Feb 2015
<https://www.isa.org/intech/2015/02017>

Big Data Big Difference

Big Data Management and Systems Integrations
Enabling the right decisions
Powering the right decisions

Industrial Big Data analytics software

How to get value out of dark data: Big data analytics

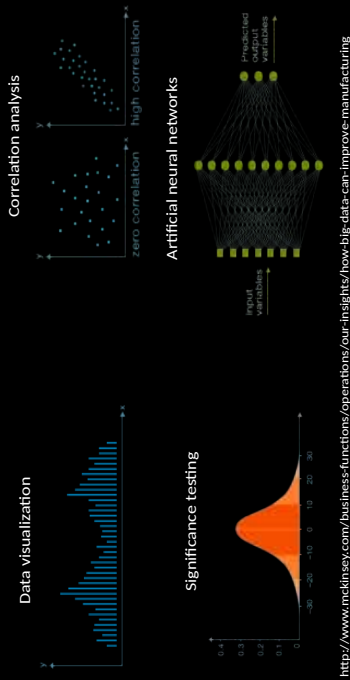

<http://www.mckinsey.com/business-functions/operations/our-insights/how-big-data-can-improve-manufacturing>

How to get value out of dark data: Big data analytics



<http://www.mckinsey.com/business-functions/operations/our-insights/how-big-data-can-improve-manufacturing>

How to get value out of dark data

Providing context for the DATA

Providing context for the PROBLEM

Providing context for DATA

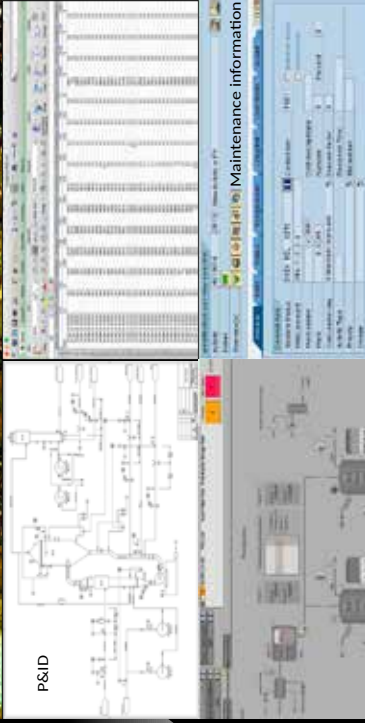

Providing context for DATA



Context of PROBLEM: Objectives of plant operation

- 1. Safety
- 2. Safety
- 3. Safety
- 4. Efficiency
- 5. Efficiency
- 6. Efficiency



Some problems we can solve with 'Dark Data', today

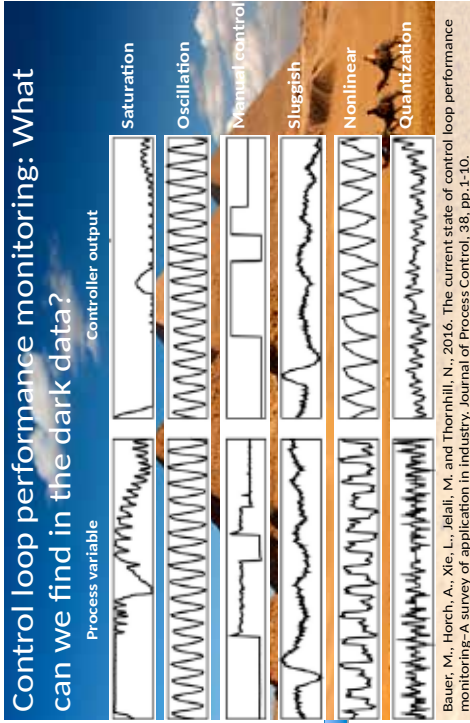
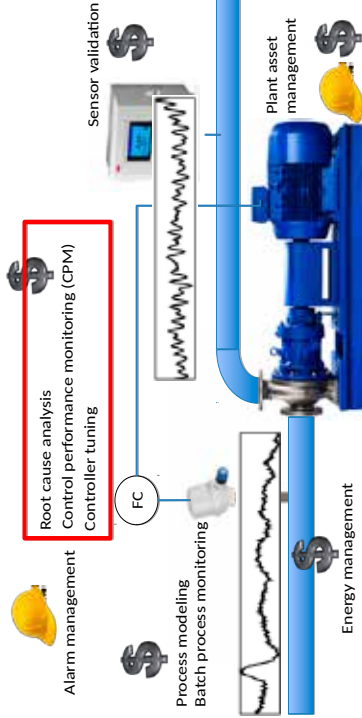

Plant-wide root cause analysis

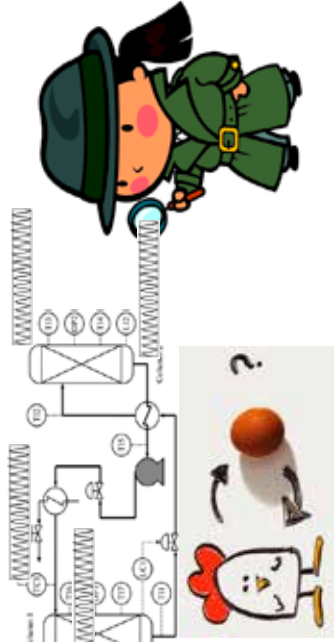

Bauer, M., Cox, J.W., Caveness, M.H., Downs, J.J. and Thornhill, N.F., 2007. Finding the direction of disturbance propagation in a chemical process using transfer entropy. *IEEE transactions on control systems technology*, 15(1), pp.12-21.

Control loop performance monitoring at ABB

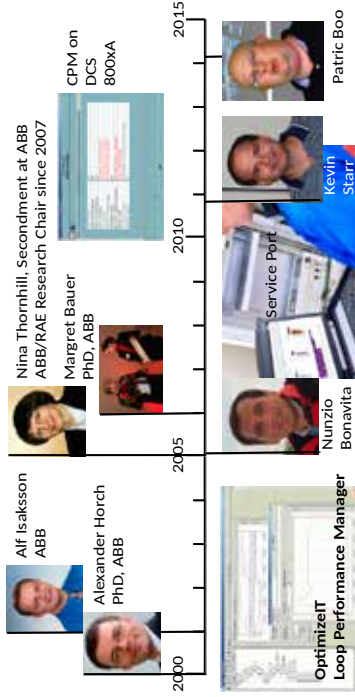

Horch, A., Cox, J. W., & Bonavita, N. (2007). Peak performance - root cause analysis of plant-wide disturbances. *ABB Review*, (1), 24-29.
 Starr, K. (2012). Expert access - anytime, anywhere. *ABB Review* (2), 12-17.
 Boo, P. (2015). A service tool grows up. *ABB Review* (1), 27-31.

ABB's Service Port – what's new It's not the algorithm...



- On site PC and off-site notifications
- Considers workflow, i.e.
 - Initialization
 - Training
 - Target setting
 - View, Scan, Track
- KPI representation
- 5,000+ installations

Starr, K. D., Petersen, H., & Bauer, M. (2016). Control loop performance monitoring--ABB's experience over two decades. *IFAC-PapersOnLine*, 49(7), 526-532.

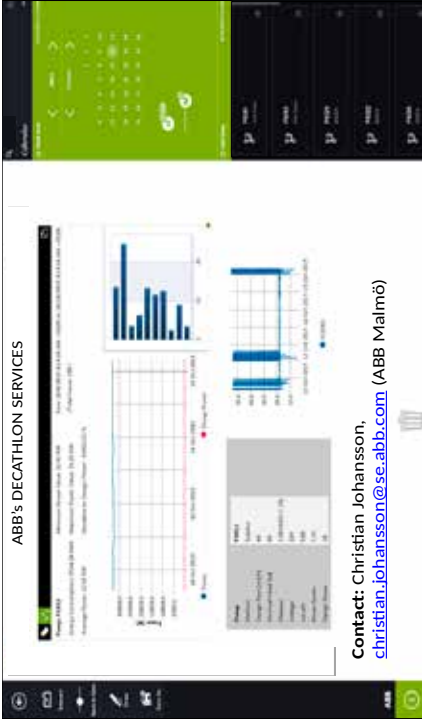

Bauer, M., Schmidt, W., Schlake, J., Larsen, P. and Johansson, C., 2016. Integrating IT and OT. Leveraging operational technology integration with Decathlon Services. *ABB Review* (2), 60-67.

Industrie 4.0: Changing requirements for control engineering

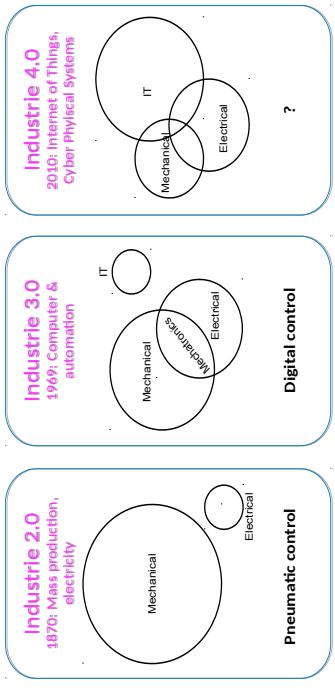

Graphic based on Kunschert & Glaser, VHS-Business Thementag Industrie 4.0, 2015



No (big, dark) data analysis without

- Context for DATA and
- Context of the PROBLEM

Consider the workflow when developing solutions
Control engineering is moving towards IT

Thanks to: Kevin Brooks, Alexander Horch, Christian Johansson

CHRISTOS GEORGAKIS

TUFTS UNIVERSITY

Data-Driven Modeling of Batch Processes: Two Methodological Generalizations of DoE

The ever-increasing availability of process data presents us with the challenge of seriously reexamining our modeling practices. Most models can be broadly categorized into two main categories: data-driven and knowledge-driven. The present seminar focuses on the development of data-driven models. It describes two generalizations of the classical design of experiments (DoE) methodology, the long-standing data-driven modeling methodology of choice. The first generalization enables the design of experiments with time-varying inputs, called Design of Dynamic Experiments (DoDE). The second generalization enables the development of a dynamic response surface model (DRSM) when time-resolved measurements are available. We will discuss how both advances are able to contribute significantly to the modeling, optimization, and understanding of batch processes for which a knowledge-driven model is not easily at hand. Two industrial applications to a Dow batch polymerization process and a Pfizer pharmaceutical reacting system demonstrate the utility of the two generalizations.



Data-Driven Modeling of Batch Processes: Two Methodological Generalizations

Time-Varying Inputs and Time-Resolved Outputs

CHRISTOS GEORGAKIS

Systems Research Institute for Chemical and Biological Processes
& Department of Chemical and Biological Engineering

TUFTS UNIVERSITY

MEDFORD MA 02155, USA

What I am Going to Tell You?

2

• Generalization of the Design of Experiments

- ◆ Design of Dynamic Experiments
 - Georgakis, C. (2013) "Design of Dynamic Experiments: A Data-Driven Methodology for the Optimization of Time-Varying Processes" *Ind. & Eng. Chem. Res.* **52** (35) pp. 12369-12382
- ◆ Dynamic Response Surface Models
 - Klebanov, N. & C. Georgakis (2016) "Dynamic Response Surface Models: A Data-Driven Approach for the Analysis of Time-Varying Process Outputs" *Ind. & Eng. Chem. Res.* **55** (14) pp. 4022-4034
- Use DoDE - DRSM to:
 - ◆ Model Processes Not Well Understood
 - ◆ **Mostly Batch but also ... Continuous Processes**
 - ◆ Optimize them
 - ◆ **Almost as Well as with a Knowledge-Driven Model (KDM)**
 - ◆ Even ... Proceed towards a KDM
 - ◆ Industrial Applications

The Limitations of DoE

3

- DoE a Very Powerful Methodology 50 Years Young!
- ◆ Full and Fractional Factorial Designs, ANOVA
- ◆ RSM: Interpolative and Linear and Nonlinear Models
 - ❖ Linear in Parameters

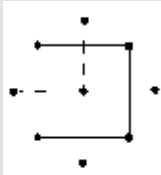
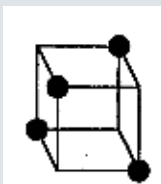
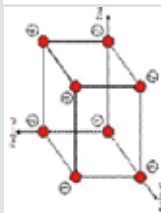

The Limitations of DoE

4

- DoE a Very Powerful Methodology 50 Years Young!
- ◆ Full and Fractional Factorial Designs, ANOVA
- ◆ RSM: Interpolative and Linear and Nonlinear Models
 - ❖ Linear in Parameters
- Two Major Limitations of DoE
 - ◆ Inputs Do NOT Vary with Time
 - ❖ Why Keep Reaction Temperature Constant?
 - ❖ Why Keep Co-reactant Flow Constant?
 - ◆ Outputs Measurements at End of Experiment
 - ❖ We Take On-Line Spectral and Other Measurement VERY frequently.
- **Our Answer is DoDE and DRSM**

PART A: The DoDE Approach

- Applicable to ANY Time-Varying Input Factor, $u(t)$
- ◆ Define Coded variable, $z(\tau)$

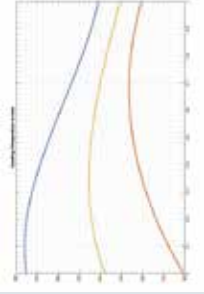

$$u(\tau) \equiv \frac{u_0(\tau) + \Delta u(\tau)z(\tau)}{\Delta u(\tau)}$$

$$z(\tau) = \frac{u(\tau) - u_0(\tau)}{\Delta u(\tau)}$$

$$\begin{cases} u_0(\tau) = \frac{u_{\max}(\tau) + u_{\min}(\tau)}{2} \\ \Delta u(\tau) = \frac{u_{\max}(\tau) - u_{\min}(\tau)}{2} \end{cases} \quad -1 \leq z(\tau) \leq +1, \quad \tau = t/t_0$$

- Parameterize Input: $z(\tau)$
- ◆ Using: $P_i(\tau)$ = Shifted Legendre Polynomials
 $P_0(\tau) = 1, P_1(\tau) = -1 + 2\tau, P_2(\tau) = 1 - 6\tau + 6\tau^2, \dots$
 Orthogonality: $\int_0^1 P_i(\tau)P_j(\tau)d\tau = 0$ for $i \neq j$
- Dynamic Sub-factors: $x_1, x_2, \dots, x_n; -1 \leq x_i \leq +1, \dots, \pm x_n \leq +1$

The nine (9) runs within the Region

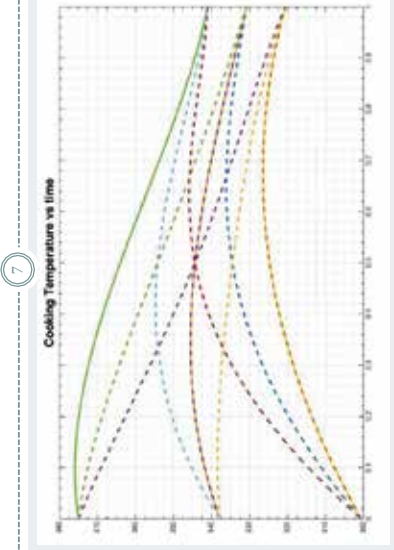

DoDE with $n=2$: a 3^2 Design

- Dynamic Factor: $z(\tau)$
- ◆ Dynamic Subfactors: x_1 and x_2
 $z(\tau) = x_1 P_0(\tau) + x_2 P_1(\tau) = x_1 + x_2(2\tau - 1); \quad \& \quad -1 \leq x_1 \pm x_2 \leq +1$

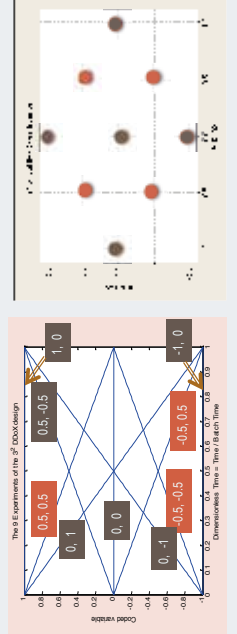

Quadratic Time Profiles

- The $2^3 = 8$ Full Factorial DoDE
- Dynamic Factor: $z(\tau)$
- ◆ Dynamic Subfactors: x_1, x_2 and x_3

$$z(\tau) = x_1 P_0(\tau) + x_2 P_1(\tau) + x_3 P_2(\tau) = x_1 + x_2(2\tau - 1) + x_3(1 - 6\tau + 6\tau^2)$$

&

$$-1 \leq x_1 \pm x_2 \pm x_3 \leq +1$$

so that

$$-1 \leq z(\tau) \leq +1$$

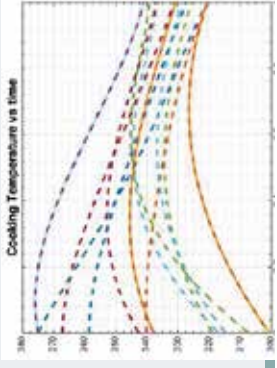

DoE & DoDE - Response Surface Models

The DoE Steps



$$y = \beta_0 + \sum_{i=1}^m \beta_i x_i + \sum_{i=1}^m \sum_{j=1}^m \beta_{ij} x_i x_j + \sum_{i=1}^m \beta_i x_i^2$$

Design of *Dynamic* Experiments: **The Same!**

Parameterize Time-Varying Input $z(\tau)$: ($\tau = t/h_p$)

$$z(\tau) = \sum_{i=0}^n \beta_i \tau^i \quad \text{= Shifted Legendre Polynomials}$$

PARAMETERIZE, DoDE experiments, RSM, OPTIMIZE

Georgakis, C. (2009) ADChEM Proceedings, Istanbul, July 2009.

Reactor Optimization via DoE & DoDE

Single Factor: Reactor Temperature

- ❖ **Data:** Conversion at 2hr + Error ($\pm 3\%$)
- ◆ Five **DoE** Experiments at T=15, 32.5 (3), and 50 °C
- ❖ **T constant with time!**
- ◆ Nine **DoDE** Experiment (T(t) linear in Time)
- ❖ **Between 15 and 50°C**
- ◆ **Optimization:** Maximum Conversion
- ◆ DoE Optimum: $x=71.44$ at $T^*=36.25$ °C
- ◆ DoDE Optimum: **$x=74.32$** , T^* from 50 to 28°C
- ◆ Model-Based (True) Optimum = **74.57%**

DoDE Example: Batch Reactor

Batch Reversible Reaction [15 < T < 50 °C]



Model-based Optimum: Decreasing Temperature Profile
Optimum Conversion=74.57% at $t_p=2.0$ hr

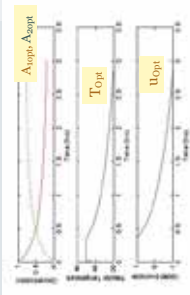

DoE
or
DoDE
???

DoDE on Isothermal Semi-Batch Reactor

Reaction Example:

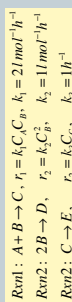

DoDE Runs: Feeding B

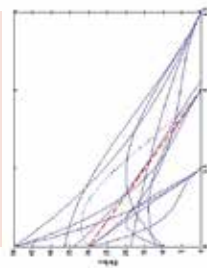

Optimal Runs

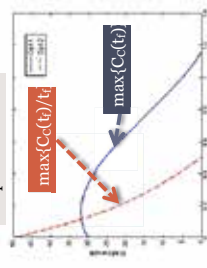

Sepracor Pharmaceutical Reaction System

Asymmetric Catalytic Hydrogenation

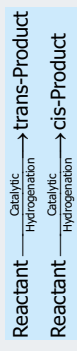

Project Specific Goals:

- ❖ **Optimize Reaction Conditions**
 - Selectivity of Asymmetric Hydrogenation
 - Minimize Catalyst Loading
- ❖ **Performance Criterion**
 - Profit = Value of Product - Cost of Reactants

Experiments and Analysis performed by Fenia Makrydiaki, PhD candidate

Design of Dynamic Experiments – DoDE

8=2³ experiments with 2 Levels & 3 (2+1-dynamic) Factors Full Factorial

- ❑ Time Variant Experiments: Temperature Profile
- ❑ Advantages: Additional degrees of freedom

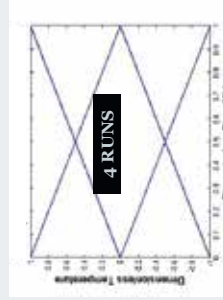

Figure A: 2 level, 2 factor, full factorial case

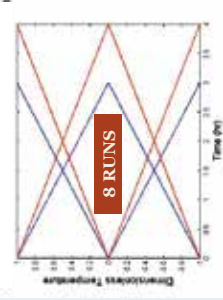
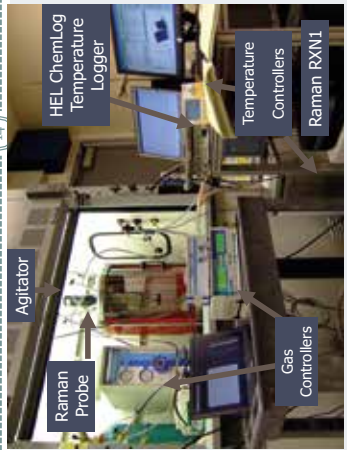

Figure B: 2 level, 2 factor, full factorial case for two time horizons.

Makrydiaki, F., Georgalis, C., & Sarantis, K. (2015). *Journal of Process Control*, 25, 1-12.

Sepracor Experimental System



Advantages

- ✓ Accurate Measurements
- ✓ Precise Pressure Control
- ✓ H₂ Consumption Monitoring
- ✓ Minimize Mass Transfer Limitations

DoE Design Table & Responses

- D-Optimal Experimental Design -17 Runs with 3 Center Points

Run	x ₁ (T)	x ₂ (P)	x ₃ (CL)	x ₄ (BT)	DE (%)	Y (%)	PI (S/I)
1	-1	1.67	0	-1	97.4	85.5	502.2
2	1	1.67	0	-1	93.7	75.7	802.7
3	-1	1.67	-1	3	97.7	98.6	155.7
4	-1	1.67	-1	-2.25	97.3	96.1	608
5	1	1.67	-1	-1	90	59.7	162.2
6	-1	-1	-1	-1	97.7	98.6	155.7
BEST DoE Run							
7	-1	1.67	-1	0	96.8	95.4	726.1
12	1	1.67	1	0	93.8	94.6	1262.9
13	0	1.67	1	-1	95.7	85.7	714.1
14	1	-1	-1	-2	94	74.7	174.7
15	0	0	0	-2.33	94.9	97.4	497.8
16	0	0	0	-2.25	95.8	97.7	501
17	0	0	0	-2.33	95.9	97.5	499.3

DoDE Design Table & Responses

(17)

- 3 Static & 2 Dynamic Factors, 21 Runs + 3 CPs

Run	x ₁ (h)	x ₂ (h)	x ₃ (h)	x ₄ (h)	x ₅ (h)	DOE (°)	Y (°)	RT (h)
1	0.00	0.00	0.00	0.00	0.00	0.00	97.4	101.6
2	0.00	0.00	1.67	0.00	0.00	0.00	97.4	101.6
3	0.00	0.00	1.67	1.67	0.00	0.00	97.2	68.46
4	0.00	0.00	1.67	1.67	1.67	0.00	96.8	21.28
5	0.00	1.67	0.00	0.00	0.00	0.00	96.8	28.83
6	0.00	1.67	0.00	0.00	1.67	0.00	96.8	28.83
7	0.00	1.67	1.67	0.00	0.00	0.00	96.8	28.83
8	0.00	1.67	1.67	1.67	0.00	0.00	96.8	28.83
9	0	-1	1.67	-1	1	96.1	83	1076.2
10	0.5	-0.5	1.67	1	1	96.2	91.4	45.69
11	0.5	-0.5	1.67	1	1	96.2	91.4	45.69
12	0.5	-0.5	1.67	1	1	96.2	91.4	45.69
13	0.5	-0.5	1.67	1	1	96.2	91.4	45.69
14	0.5	-0.5	1.67	1	1	96.2	91.4	45.69
15	0.5	-0.5	1.67	1	1	96.2	91.4	45.69
16	0.5	-0.5	1.67	1	1	96.2	91.4	45.69
17	0.5	-0.5	1.67	1	1	96.2	91.4	45.69
18	0.5	-0.5	1.67	1	1	96.2	91.4	45.69
19	0.5	-0.5	1.67	0	0	96.8	96.1	911.3
20	0.5	-0.5	1.67	0	0	96.8	96.1	911.3
21	0.5	-0.5	1.67	0	0	96.8	96.1	911.3
22	0.5	-0.5	1.67	0	0	96.8	96.1	911.3
23	0.5	-0.5	1.67	0	0	96.8	96.1	911.3
24	0.5	-0.5	1.67	0	0	96.8	96.1	911.3

BEST DOE RUN (Run 9): 96.1, 83, 1076.2
BEST DoDE RUN (Run 7): 96.8, 95.4, 726.1
48% improvement in response (Run 9 vs Run 7)

What Did I Tell You so Far?

(18)

- Design of Dynamic Experiments (DoDE)
 - First Generalization of DoE
 - New Set of Inputs: **TIME-VARYING**
 - Effective Optimization of Processes
 - SMALL distance from Model-Based Optimum

PART B: Dynamic RSM (DRSM)

(19)

- Use Time-Resolved Output Data
- Classical RSM: $y = \beta_0 + \sum_{i=1}^n \beta_i x_i + \sum_{i=2}^n \beta_i x_i^2 + \sum_{i=1}^{n-1} \sum_{j=i+1}^n \beta_{ij} x_i x_j + \sum_{i=1}^n \beta_i x_i^3$
- Dynamic RSM: $y(\tau) = \beta_0(\tau) + \sum_{i=1}^n \beta_i(\tau) x_i + \sum_{i=2}^n \beta_i(\tau) x_i^2 + \sum_{i=1}^{n-1} \sum_{j=i+1}^n \beta_{ij}(\tau) x_i x_j + \sum_{i=1}^n \beta_i(\tau) x_i^3$
 K = # of C Measurements in Time # of $\beta(\tau)$ functions = $1+n+0.5n(n-1)+1$
- Parameterization of $\beta_j(\tau) = \gamma_{j,0} P_0(\tau) + \gamma_{j,1} P_1(\tau) + \dots + \gamma_{j,R} P_{R-1}(\tau)$
 R = # of Polynomials
- # of Model parameters < # of Data **R < K**

DRSM for Simple Batch Reaction

(20)

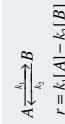

$$k_1 = k_{10} \exp\left(-\frac{E_1}{RT}\right), \quad k_{10} = 1.32 \times 10^8 \text{ h}^{-1}, \quad E_1 = 10,000 \text{ kcal}$$

$$k_2 = k_{20} \exp\left(-\frac{E_2}{RT}\right), \quad k_{20} = 5.25 \times 10^{13} \text{ h}^{-1}, \quad E_2 = 20,000 \text{ kcal}$$

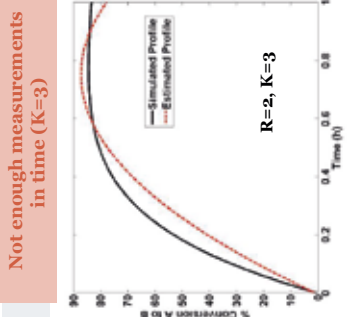

Not enough measurements in time (K=3)

Statistical Measure of Accuracy

(21)

$$\hat{S}S_{err}(R, K) = \frac{\sum_{i=1}^K \sum_{j=1}^n \{y_{ij}(t) - \hat{y}_{ij}(t)\}^2}{\sum_{i=1}^K \sum_{j=1}^n \{y_{ij}(t)\}^2}$$

- **Unmodeled Variance:**

$$\hat{S}S_{var} = \frac{\sum_{i=1}^K \sum_{j=1}^n \{y_{ij}(t) - \bar{y}_{ij}(t)\}^2}{\sum_{i=1}^K \sum_{j=1}^n \{\bar{y}_{ij}(t)\}^2}$$

- **Normal Variability:**

Null Hypothesis H_0 : $\hat{S}S_{var} = \hat{S}S_{err}(R, K)$
 Alternative Hypothesis H_1 : $\hat{S}S_{var} < \hat{S}S_{err}(R, K)$

$$F_1(R, K) = \frac{\hat{S}S_{var}(R, K) / n_1}{\hat{S}S_{err}(R, K) / (MK - Q)}$$

- **F-Statistic:**

D-RSM Model (R=7, K=14)

(23)

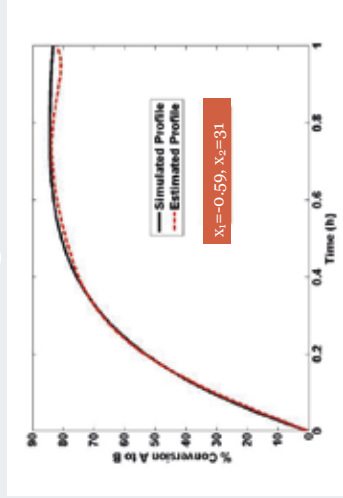

Reactor Example:

K=Measurements, R=Polynomials

(22)

Table 3. p-values of F-test for DSM of A \rightarrow B conversion in batch reactor

R	3	4	5	6	7	8	9	
1	1.00	1.00	1.00	1.00	1.00	1.00	1.00	
2	1.00	1.00	1.00	1.00	1.00	1.00	1.00	
3	1.00	1.00	1.00	1.00	1.00	1.00	1.00	
4	0.97	1.00	1.00	1.00	1.00	1.00	1.00	
5	0.51	0.99	0.90	0.82	0.48	0.70	0.03	
6					0.34	0.48	0.03	
7						0.47	0.01	
8							0.58	
9								0.14

K = number of time-resolved measurements; R = number of polynomials

if $p(R, K) \leq 0.95$ the Null Hypothesis fails to be rejected \Rightarrow Model GOOD
 if $p(R, K) > 0.95$ the Null Hypothesis is rejected

More Complex Semi-Batch Case

(24)

- Three inter-related reactions
- C is the desired product
- Reactant B is fed in semi-batch mode

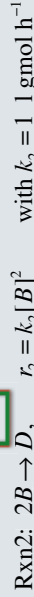

- DRSMs for A(t), B(t), C(t), D(t), and E(t)

Statistical Test of Goodness-of-Fit (GoF)

Table 6. Corresponding F-test p values for DRSM of product [C] in semi-batch 3-reaction network

R	3	4	5	6	7	8	9	10
1	1.00	1.00	1.00	1.00	1.00	1.00	1.00	1.00
2	1.00	1.00	1.00	1.00	1.00	1.00	1.00	1.00
3	1.00	1.00	1.00	1.00	1.00	1.00	1.00	1.00
4		1.00	1.00	1.00	1.00	1.00	1.00	1.00
5			2.33E-06	8.06E-06	2.89E-05	1.45E-02	2.22E-05	
6				3.18E-26	1.22E-29	5.18E-27	6.14E-37	
7					6.89E-36	9.60E-38	1.07E-50	
8						9.60E-38	1.07E-50	
9							1.07E-50	

K = number of time-resolved measurements; R = number of polynomials

Excellent Model

Some C(t) Profiles

- Excellent fits:

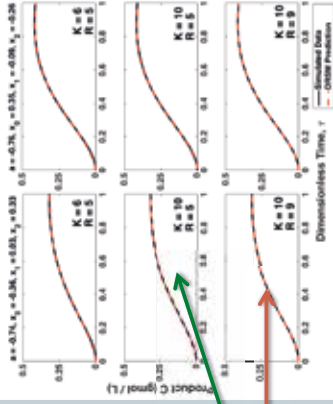

No Significant Difference Using Stepwise Regression

Part C: DRSM Usage → Door to Knowledge

- Revisit Semi-Batch Reactor Example
- Five DRSMs at Hand

$$\begin{aligned}
 c_1(t) &= \beta_{01}(t) + \sum_{i=1}^K \beta_{1i}(t)x_i + \sum_{j=1}^K \beta_{2j}(t)x_j^2 + \sum_{k=1}^K \beta_{3k}(t)x_k^3 \\
 c_2(t) &= \beta_{02}(t) + \sum_{i=1}^K \beta_{1i}(t)x_i + \sum_{j=1}^K \beta_{2j}(t)x_j^2 + \sum_{k=1}^K \beta_{3k}(t)x_k^3 \\
 c_3(t) &= \beta_{03}(t) + \sum_{i=1}^K \beta_{1i}(t)x_i + \sum_{j=1}^K \beta_{2j}(t)x_j^2 + \sum_{k=1}^K \beta_{3k}(t)x_k^3 \\
 c_4(t) &= \beta_{04}(t) + \sum_{i=1}^K \beta_{1i}(t)x_i + \sum_{j=1}^K \beta_{2j}(t)x_j^2 + \sum_{k=1}^K \beta_{3k}(t)x_k^3 \\
 c_5(t) &= \beta_{05}(t) + \sum_{i=1}^K \beta_{1i}(t)x_i + \sum_{j=1}^K \beta_{2j}(t)x_j^2 + \sum_{k=1}^K \beta_{3k}(t)x_k^3
 \end{aligned}$$

- Can Calculate Derivatives wrt Time

$$\frac{dc_i(t)}{dt} = \frac{d\beta_{0i}(t)}{dt} + \sum_{j=1}^K \frac{d\beta_{1j}(t)}{dt} x_j + \sum_{j=1}^K \frac{d\beta_{2j}(t)}{dt} x_j^2 + \sum_{k=1}^K \frac{d\beta_{3k}(t)}{dt} x_k^3$$

... for ALL experiments

Calculate Rate of Appearance (Disappearance)

- Calculate at 100 time points in each Run:
 - $t = 0.01, 0.02, \dots, 0.99, 1.00$
- Can plot the Rates vs. Time
- Can Understand what is Happening

$$\begin{aligned}
 r_i(t) &= \frac{dc_i(t)}{dt}, \quad r_r(t) = \frac{dc_r(t)}{dt} \\
 r_p(t) &= \frac{dc_p(t)}{dt}, \quad r_d(t) = \frac{dc_d(t)}{dt} \\
 \text{but } r_i(t) &= -\frac{dc_i(t)}{dt}, \quad r_r(t) = \frac{dc_r(t)}{dt}
 \end{aligned}$$

Experiment 1

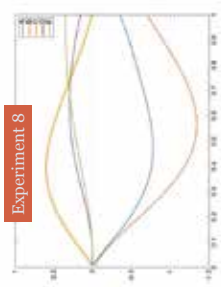

Discover the Stoichiometry

20

- Define Big Rate Data Matrix: DataM

$$\text{DataM} = \begin{pmatrix} D_1 \\ D_2 \\ \vdots \\ D_n \end{pmatrix}; D_i = \text{Data from } i\text{-th Experiment}$$

$$Q = 1 + n + 0.5n(n-1) + n + 6(3)$$
 for $n = 2 \Rightarrow Q = 12(9)$

$$D_i = \begin{pmatrix} r_{A_i}(0.01) & r_{A_i}(0.02) & r_{A_i}(0.05) & r_{A_i}(0.10) & r_{A_i}(0.20) \\ r_{B_i}(0.01) & r_{B_i}(0.02) & r_{B_i}(0.05) & r_{B_i}(0.10) & r_{B_i}(0.20) \\ r_{C_i}(0.01) & r_{C_i}(0.02) & r_{C_i}(0.05) & r_{C_i}(0.10) & r_{C_i}(0.20) \\ r_{D_i}(0.01) & r_{D_i}(0.02) & r_{D_i}(0.05) & r_{D_i}(0.10) & r_{D_i}(0.20) \\ r_{E_i}(0.01) & r_{E_i}(0.02) & r_{E_i}(0.05) & r_{E_i}(0.10) & r_{E_i}(0.20) \end{pmatrix}$$
- DataM is a 909 x 5 matrix !!!
- SVD of DataM
 - S** has three Dominant Singular Values \rightarrow three Reactions !!
 - Matrix **V** is KEY to Stoichiometry

$$\text{SVD}(\text{DataM}) = \mathbf{USV}^T$$

Testing Stoichiometries (measure A, B, C, and D - NO E)

31

- SVD Results

$$\mathbf{V}^T = \begin{pmatrix} 0.4125 & 0.8456 & -0.2608 & -0.2164 & 0 \\ -0.2841 & 0.3233 & 0.8503 & -0.3029 & 0 \\ 0.7620 & -0.1172 & 0.4571 & 0.4435 & 0 \end{pmatrix}$$

$$\mathbf{R}_1: A + B \rightarrow C$$

$$\mathbf{R}_2: 2B \rightarrow D$$

$$\mathbf{R}_3: C \rightarrow E$$
- Test TRUE Stoichiometry

$$\mathbf{N} = \begin{pmatrix} -1 & -1 & 1 & 0 & 0 \\ 0 & -2 & 0 & 1 & 0 \\ 0 & 0 & -1 & 0 & 1 \end{pmatrix}$$
 - Score: 99.67%
- Test **Incorrect** Stoichiometry

$$\mathbf{N} = \begin{pmatrix} -1 & -1 & 1 & 0 & 0 \\ 0 & -1 & 0 & 1 & 0 \\ 0 & 0 & -1 & 0 & 1 \end{pmatrix}$$
 - Score: 64.87%
- Can Test **One** Reaction at a Time

Testing Stoichiometries (measure A, B, C, D, and E)

30

- SVD Results

$$\mathbf{V}^T = \begin{pmatrix} 0.4072 & 0.8365 & -0.2557 & -0.2145 & -0.1516 \\ -0.2596 & 0.2086 & 0.7629 & -0.2333 & -0.5027 \\ 0.5955 & -0.2826 & 0.0140 & 0.4417 & -0.6084 \end{pmatrix}$$

$$\mathbf{R}_1: A + B \rightarrow C$$

$$\mathbf{R}_2: 2B \rightarrow D$$

$$\mathbf{R}_3: C \rightarrow E$$
- TEST: $\mathbf{N} = \mathbf{NV}^T$; is $\mathbf{N}_i = \mathbf{N}^{??}$

$$\mathbf{N} = \begin{pmatrix} -1 & -1 & 1 & 0 & 0 \\ 0 & -2 & 0 & 1 & 0 \\ 0 & 0 & -1 & 0 & 1 \end{pmatrix}$$
 - Test **TRUE** Stoichiometry
 - Score: 99.74%
- Test **Incorrect** Stoichiometry

$$\mathbf{N} = \begin{pmatrix} -1 & -1 & 1 & 0 & 0 \\ 0 & -1 & 0 & 1 & 0 \\ 0 & 0 & -1 & 0 & 1 \end{pmatrix}$$
 - Score: 64.97%
- Can Test **One** Reaction at a Time

Calculate Reaction Rates

32

- From: $r_A(\tau), r_B(\tau), r_C(\tau), r_D(\tau), r_E(\tau)$
- To: $r_1(\tau), r_2(\tau), r_3(\tau)$

Reaction Rates Experiment 4

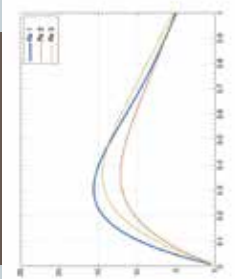

Reaction Rates Experiment 8

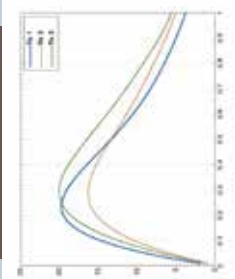

Derive Kinetic Laws

33

- From: $r_1(\tau)$, $C_A(\tau)$, $C_B(\tau)$
- ◆ TO: Kinetic Rates $r_1(\tau)=f(C_A(\tau), C_B(\tau))$
- Work in Progress
- ◆ Stay ... Tuned

What did I just Tell you?

34

- DRSM is a Generalization of RSM
- ◆ Using Time-Resolved Measurements
- ◆ Excellent Approximation of Composition Profiles
- ◆ Stepping Stone to Stoichiometry and a Kinetic Model

Industrial Applications

35

- Dow Batch Polymerization Reactor
- ◆ Use DoDE to Increase Productivity by 20%
 - ◆ Presented at the Houston AIChE Meeting
 - ◆ Can Give you the Highlights
- Pfizer Pharmaceutical Reaction System
- ◆ Develop DRSMs & Discover Complex Stoichiometry
 - ◆ 10 Species involved in 8 reactions
- ExxonMobil Continuous Polymerization Process
- ◆ Develop Meta-Models of KDM
 - ◆ Make Them More Accurate with Plant Data
 - ◆ USE for Optimization and Control Between SS Transition

DRSM Model for the Optimization and Control of Batch Processes

36

DYCOPS 2016

Z. Wang, N. Klebanov & C. Georgakis
Tufts University
 Medford, MA 02155, USA

Control for Maximum Yield

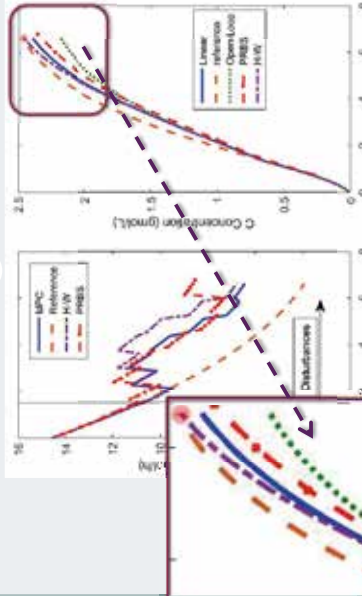

What You Should Remember Tomorrow

38

- DoDE: First Generalization of DoE
- ◆ Time-varying Inputs
- DRSM: Second Generalization of DoE
- ◆ Using Time-Resolved Outputs
 - ◆ Excellent Approximation of Composition Profiles
 - ◆ Stepping Stone to a Kinetic Model
- Towards Non-Linear Models for Control
- Potential Benefits: **Substantial**

THANK YOU

MAY I ANSWER YOUR QUESTIONS?

MARTIN GUAY

QUEEN'S UNIVERSITY

Performance improvements in extremum seeking control

In this talk, we will discuss a new approach to address the removal of time-scale separation in the design of extremum-seeking controllers for unknown non-linear dynamical systems. A fast extremum seeking controller design approach is proposed to minimize the impacts of time-separation on the transient performance of control systems. The application of the ESC approach to feedback stabilization, observer design and distributed optimization will be discussed. We will also present a number of successful industrial implementations of ESC.



Performance Improvements in Extremum Seeking Control

M. Guay



September 30, 2016, LCCC Process Control Workshop, Lund

- 1 Background
- 2 Perturbation based ESC
 - Basic perturbation based ESC
 - Proportional-integral ESC
- 3 Recursive least-squares approach
 - RLS Proportional integral ESC
- 4 Discrete-time systems
- 5 Distributed network optimization
- 6 Concluding Remarks and Perspective

Introduction

- Extremum seeking is a real-time optimization technique.

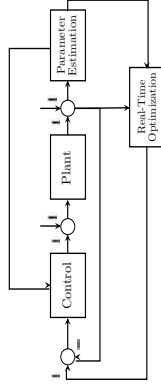

Figure : Basic RTO loop.

- RTO is a supervisory system designed to monitor and improve process performance.
- It uses process data to move the process to operating points that are optimal wrt a meaningful user-defined metric

Introduction

- In most applications, RTO exploits process models and optimization techniques to compute optimal steady-state operating conditions
 - ▶ Control objectives vs. Optimization objectives
 - ▶ the accuracy of the (steady-state) model
 - ▶ robustness of the RTO approach
 - ▶ flexibility of the control system
- Success of RTO relies on
- In the absence of accurate process descriptions (model-based) RTO yields erratic results

Successful RTO requires integrated solutions.

Introduction

- Extremum Seeking Control (ESC) is a model free technique that relies on minimal assumptions concerning:
 - ▶ the process model
 - ▶ the objective function
 - ▶ the constraints
- ESC only requires the measurement of the objective function and the constraints
- Considerable appeal in practice
 - ▶ Achieves RIO objectives without the need for complex model-based formulations.

5 / 59

Introduction

Basic ESC objectives:

- Given an (unknown) nonlinear dynamical system and (unknown) measured cost function:

$$\dot{x} = f(x, u) \quad (1)$$

$$y = h(x) \quad (2)$$

- The objective is to steer the system to the equilibrium x^* and u^* that achieves the minimum value of $y (= h(x^*))$.

7 / 59

Introduction

- Extremum-seeking control (ESC) has been the subject of considerable research effort over the last decade.
- Mechanism dates back to the 1920s [Leblanc, 1922]
 - ▶ Objective is to drive a system to the optimum of a measured variable of interest [Tan et al., 2010]
- Revived interest in the field was primarily sparked by Krstic and co-workers [Krstic and Wang, 2000]
 - ▶ Provided an elegant proof of the convergence of a standard perturbation based ESC for a general class of nonlinear systems

6 / 59

Problem Definition

- The objective is to steer the system to the equilibrium x^* and u^* that achieves the minimum value of $y (= h(x^*))$.
- ▶ The equilibrium (or steady-state) map is the n dimensional vector $\pi(u)$ which is such that:

$$f(\pi(u), u) = 0.$$

- ▶ The equilibrium cost function is given by:

$$y = h(\pi(u)) = \ell(u) \quad (3)$$

- ▶ The problem is to find the minimizer u^* of $y = \ell(u^*)$.

8 / 59

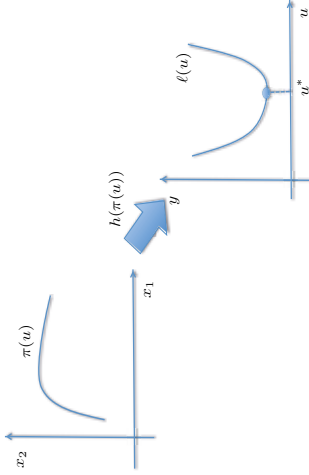

9 / 59

- Closed-loop dynamics are:

$$\begin{aligned} \dot{x} &= f(x, \hat{u}(t) + a \sin(\omega t)) \\ \dot{\hat{u}} &= -\omega k \xi \\ \dot{\xi} &= -\omega \omega_l \xi + \omega \frac{\omega_l}{a} (h(x) - \eta) \sin(\omega t) \\ \dot{\eta} &= -\omega \omega_h \eta + \omega \omega_h h(x). \end{aligned}$$

- Tuning parameters are:

- ▶ k the adaptation gain
- ▶ a the dither signal amplitude
- ▶ ω the dither signal frequency
- ▶ ω_l and ω_h the low-pass and high-pass filter parameters

11 / 59

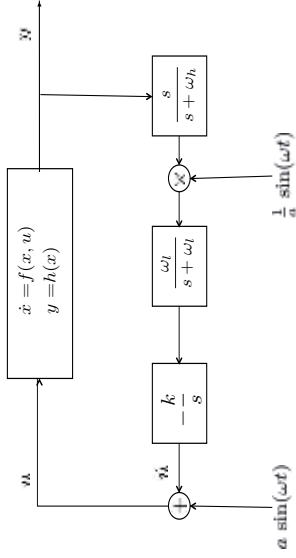

10 / 59

- The stability analysis [Krstic and Wang, 2000] relies on two components:
 - 1 an averaging analysis of the persistently perturbed ESC loop
 - 2 a time-scale separation of ESC closed-loop dynamics between the system dynamics and the quasi steady-state extremum-seeking task.
- This is a very powerful and very general result.
- Analysis confirms properties: *small a*, *small ω*, *small k*.
- Convergence is slow with limited robustness.

12 / 59

Proportional Integral ESC

Limitations associated with the two time-scale approach to ESC remains problematic.

- Two (or more) time-scale assumption is required to ensure that optimization operates at a quasi steady-state time-scale
- Convergence is very slow.
- Limits applicability in practice.

Improvement in transient performance are possible:

- Standard ESC is an integral controller → Performance limitation
- Add proportional action.

Proportional Integral ESC

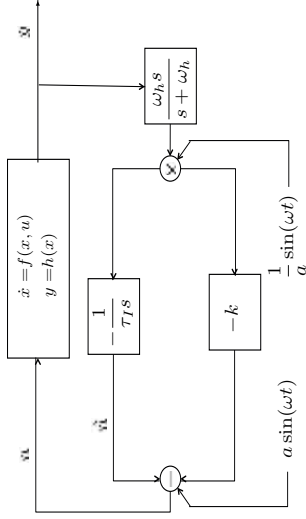

Proportional Integral ESC

- Proposed PI-ESC algorithm:

$$\begin{aligned} \dot{x} &= f(x) + g(x)u \\ \dot{v} &= -\omega_h v + y \\ \dot{\hat{u}} &= -\frac{1}{\tau_I} (-\omega_h^2 v + \omega_h y) \sin(\omega t) \\ u &= -\frac{k}{a} (-\omega_h^2 v + \omega_h y) \sin(\omega t) + \hat{u} + a \sin(\omega t). \end{aligned}$$

- Tuning parameters:

- ▶ k and τ_I are the proportional and integral gain
- ▶ a and ω are the dither amplitude and frequency
- ▶ $\omega_h (> \omega)$ is the high-pass filter parameter.

Proportional Integral ESC

Theorem 1

Consider the nonlinear closed-loop PIEESC system with cost function $y = h(x)$. Let Assumptions 1, 2, 3 and 4 hold. Then

- there exists a τ_I^* such that for all $\tau_I > \tau_I^*$ the trajectories of the nonlinear system converge to an $\mathcal{O}(1/\omega)$ neighbourhood of the unknown optimum equilibrium, $x^* = \pi(u^*)$,
- there exists $\omega^* > 0$ such that, for any $\omega > \omega^*$, the unknown optimum is a practically stable equilibrium of the PIEESC system with a region of attraction whose size grows with the ratio $\frac{a}{k}$,
- $\|x - x^*\|$ enters an $\mathcal{O}(\frac{1}{\omega}) + \mathcal{O}(\frac{k}{\omega a}) + \mathcal{O}(\frac{a}{\omega})$ neighbourhood of the origin and $\|\hat{u} - u^*\|$ enters an $\mathcal{O}(\frac{1}{\omega}) + \mathcal{O}(\frac{1}{\omega a \tau_I}) + \mathcal{O}(\frac{a}{\tau_I \omega})$ of the origin.

- Proof of theorem demonstrates that:
 - ▶ the proportional action minimizes the impact of the time scale separation
 - ▶ the integral action acts as a standard perturbation based ESC
 - ▶ Combined action guarantees stabilization of the unknown equilibrium
 - ▶ With fast convergence
- Impact of dither signal is inversely proportional to the frequency
- Size of ROA is proportional to $\frac{a}{k}$.
- **PIESC acts as a dynamic output feedback nonlinear controller.**

17 / 59

Example 1

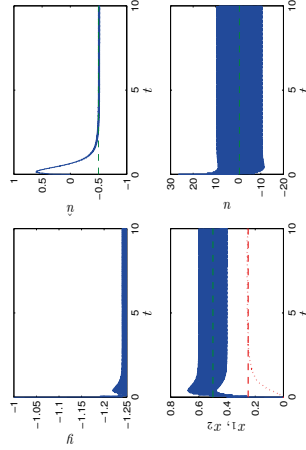

19 / 59

Example 1

We consider the following dynamical system taken from Guay and Zhang [2003]:

$$\begin{aligned} \dot{x}_1 &= x_1^2 + x_2 + u \\ \dot{x}_2 &= -x_2 + x_1^2 \end{aligned}$$

The cost function to be minimized is given by: $y = -1 - x_1 + x_1^2$.

- the optimum cost is $y^* = -1.25$ and occurs at $u^* = -0.5$, $x_1^* = 0.5$, $x_2^* = 0.25$
- The tuning parameters are chosen as: $k = 10$, $\tau_I = 0.1$, $a = 10$, $\omega = 100$ with $\omega_h = 1000$.
- Outperforms the model-based approach of Guay and Zhang [2003]

18 / 59

RLS Proportional Integral ESC

- Parameterize y as:

$$\dot{y} = \theta_0 + \theta_1 u = \phi^T \theta \tag{4}$$
 where $\phi = [1, u^T]^T$ and $\theta = [\theta_0, \theta_1^T]^T$.
- θ_0 and θ_1 are unknown time-varying parameters.
- Proposed PI-ESC given by:

$$\begin{aligned} u &= -k\hat{\theta}_1 + \hat{u} + d(t) \\ \hat{u} &= -\frac{k}{\tau_I} \hat{\theta}_1 \end{aligned}$$

- where
- ▶ $\hat{\theta}_1$ is the estimation of θ_1 .
 - ▶ k is the proportional gain
 - ▶ τ_I is the integral time constant.

20 / 59

Parameter Estimation

The proposed time-varying parameter estimation scheme consists of an output prediction mechanism.

$$\hat{y} = \phi^T \hat{\theta} + Kc + c^T \hat{\theta} \quad (5)$$

$$\dot{c}^T = -Kc^T + \phi^T \quad (6)$$

$$\dot{\hat{\eta}} = -K\hat{\eta}. \quad (7)$$

where

- $\hat{\theta}$ are parameter estimates
- $c = y - \hat{y}$ and $\hat{\theta} = \theta - \hat{\theta}$
- K is a positive constant to be assigned
- $c \in \mathbb{R}^p$ is the solution of the differential equation:

Parameter Estimation

The parameter estimation law is given by:

$$\dot{\Sigma}^{-1} = -\Sigma^{-1}cc^T\Sigma^{-1} + k_T\Sigma^{-1} - \delta\Sigma^{-2} \quad (8)$$

with initial condition $\Sigma^{-1}(t_0) = \frac{1}{\alpha}I$, and the parameter update law:

$$\dot{\hat{\theta}} = \text{Proj}(\Sigma^{-1}(c(e - \hat{\eta}) - \frac{\delta}{2}\hat{\theta}), \Theta^0), \quad \hat{\theta}(t_0) = \theta^0 \in \Theta^0, \quad (9)$$

where δ is a positive constant. $\text{Proj}\{\phi, \hat{\theta}\}$ denotes a Lipschitz projection operator Krstic et al. [1995] such that

$$-\text{Proj}\{\phi, \hat{\theta}\}^T \hat{\theta} \leq -\phi^T \hat{\theta}, \quad (10)$$

$$(11)$$

where $\Theta \triangleq B(\hat{\theta}, z_\theta)$, $\hat{\theta}(t_0) \in \Theta^0 \implies \hat{\theta} \in \Theta, \forall t \geq t_0$

22 / 59

Parameter Estimation

- **Assumption 4:** There exists constants $\alpha_1 > 0$ and $T > 0$ such that

$$\int_t^{t+T} c(\tau)c(\tau)^T d\tau \geq \alpha_1 I \quad (12)$$

$\forall t > 0$. \square

Theorem 1

Let Assumptions 1 to 4 hold. Consider the extremum-seeking controller and the parameter estimation algorithm. Then there exists tuning parameters k, k_T, K and τ_1^ such that for all $\tau_1 > \tau_1^*$ the system converges exponentially to an $\mathcal{O}(D/\tau_1)$ neighbourhood of the minimizer x^* of the measured cost function y .*

23 / 59

Example 2

Consider the following system

$$\begin{aligned} \dot{x}_1 &= x_2 \\ \dot{x}_2 &= -x_1 - x_2 + u \end{aligned}$$

with the following cost function:

$$y = 4 + (x_1 - 1.5)^2 + x_2^2.$$

- Tuning parameters: $k_T = 20, K = 20I, k = 0.25$ and $\tau_1 = 0.15$.
- $d(t) = 0.1 \sin(10t)$.
- The initial conditions are $\hat{\theta}(0) = [0, -1]^T, x_1(0) = x_2(0) = u(0) = 0$.

24 / 59

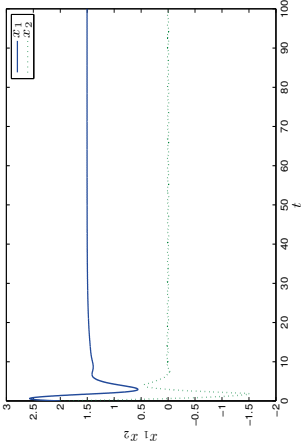

Figure : State trajectories as a function of time.

Discrete-time ESC

- Design of discrete-time ESC systems is not as prevalent:
 - ▶ Discrete-time ESC [Ariyur and Krstic, 2003], [Choi et al., 2002] with application to PID tuning in [Killingsworth and Krstic, 2006].
 - ▶ Adaptive estimation approach [Guay, 2014]
 - ▶ Discrete-time ESC subject to stochastic perturbations [Manzie and Krstic, 2009] and [Liu and Krstic, 2014b].
 - ▶ Approximate parameterizations of the unknown cost function [Ryan and Speyer, 2010].
 - ▶ Analysis of nonlinear-optimization algorithms [Teel and Popovic, 2001].
 - ▶ Global sampling methods [Nesic et al., 2013].

Discrete-time techniques cannot be derived directly from continuous-time techniques.

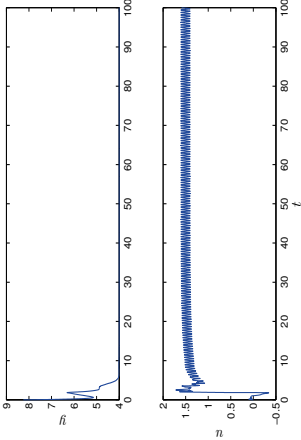

Figure : Input $u(t)$ and output $y(t)$.

Problem Definition

ESC objectives:

- Given an (unknown) nonlinear discrete-time dynamical system and (unknown) measured cost function:

$$x_{k+1} = x_k + f(x_k) + g(x_k)u_k \tag{13}$$

$$y_k = h(x_k) \tag{14}$$

- The objective is to steer the system to the equilibrium x^* and u^* that achieves the minimum value of $y(=h(x^*))$.

Simulation: Example 1

Consider a simple, 1st order, dynamical system:

$$\begin{aligned}x_{k+1} &= 0.8x_k + u_k \\ y_k &= (x_k - 3)^2 + 1\end{aligned}$$

The steady-state optimum occurs at

$$\begin{aligned}u^* &= 0.6 \\ y^* &= 1.\end{aligned}$$

33 / 59

Distributed Extremum seeking control

Internet network control design

- The discrete-time ESC approach can be generalized for the design of distributed optimization and control of complex unknown networks
- ESC can adjust local actions in the absence of any knowledge about the underlying dynamics and network interactions
- Application to air-based (balloon) internet system design

35 / 50

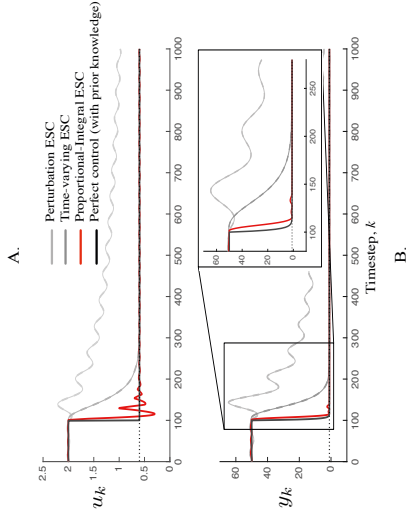

34 / 59

Air-based internet

Why balloons?

- Float in the stratosphere (10–50 km altitude)
- High enough to avoid weather and airplanes
 - ▶ Airplanes typically fly below 15 km altitude
- Low enough for fast connections without lag
 - ▶ Satellites fly in low-earth orbit at around 1200 km altitude
- Float passively to minimize energy costs
- Solar panels help balloons stay up for hundreds of days

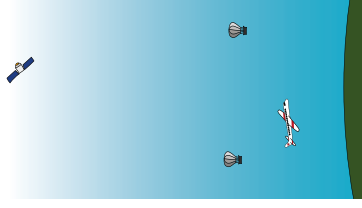

36 / 50

Modeling balloon dynamics

Basics

- Each balloon moves in a spherical shell
- Altitude is limited to 10–50km
- Earth's radius is 6371km so we can neglect altitude
- i^{th} balloon's position can be represented by a point, $q_i \in \mathbb{S}^2$.
- Altitude, u_i , will be used as an input parameter

Assumption 1

The balloons move exactly with the wind currents and assume dynamics characterized by local wind patterns.

37 / 59

Modeling balloon dynamics

Nonlinear dynamic model

- For each altitude, u_i , let $f_{u_i} : \mathbb{R} \times \mathbb{S}^2 \rightarrow \mathbb{T}\mathbb{S}^2$ be a time varying vector field on the sphere. Then the balloon's dynamics are: (16)
- For simulation: An approximate model of f_{u_i} can be created by interpolating gridded wind data from the NOAA

$$\dot{q}_i = f_{u_i}(t, q_i)$$

Assumption 2

The time-varying vector fields $f_{u_i} \in \mathfrak{X}(\mathbb{R}, \mathbb{S}^2)$ are smooth and the map $u_i \mapsto f_{u_i}$ is smooth

38 / 59

Voronoi partitions

Definition

- Let Γ_i be the region of Earth where users are connected to balloon i
- What should the regions Γ_i look like?
- Define the Voronoi partition by:

$$\Gamma_i = \{q \in \mathbb{S}^2 \mid \mathbb{G}(q, q_i) < \mathbb{G}(q, q_j) \forall j \neq i\} \quad (17)$$

where $\mathbb{G}(\cdot, \cdot)$ is the round metric on \mathbb{S}^2 .

- Voronoi partitions ensure each user is connected to the nearest balloon

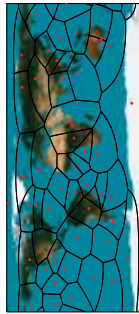

39 / 59

Controller design

Control objectives

- Connect all users to a balloon with a satisfactory connection
- Balloons should coordinate their own motion
- The control algorithm should rely on measurements and communication but not a model
- Balloons must float passively with the wind
- Each balloon should try to position itself such that internet traffic is shared equally between all balloons

40 / 59

Controller design

Existing approaches

- Google intends on using “some complex algorithms and lots of computing power” (Official Google Blog [2013])
- Sniderman showed that lots of computing power is unnecessary (Sniderman et al. [2015])
 - ▶ Uses a geometric, block-circulant approach
 - ▶ Algorithms rely on a linear model of wind currents
 - ▶ Simulations only performed on a circle and do not generalize to a sphere
- Can we solve control a non-linear 2-dimensional system without lots of computing power?

Controller design

Distributed architecture

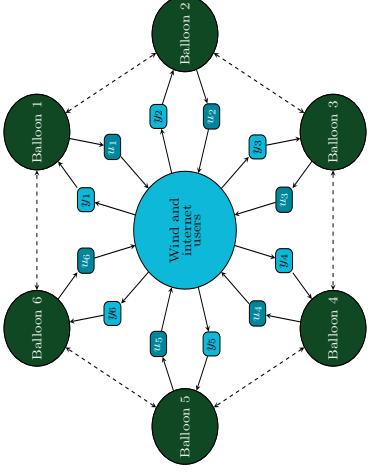

41 / 59

Controller design

Distributed architecture as seen by one balloon

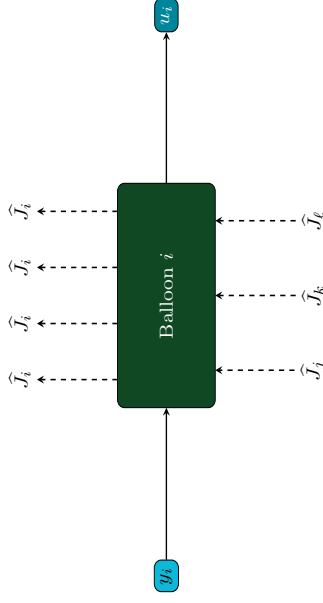

43 / 59

Controller design

Consensus estimation

Each balloon measures y_i and estimates $\frac{1}{p}J$ by a consensus algorithm

$$\begin{bmatrix} \hat{J}[k+1] - \hat{J}[k] \\ \rho[k+1] - \rho[k] \end{bmatrix} = \begin{bmatrix} -\kappa_P I - \kappa_I L & -I \\ \kappa_P \kappa_I L & 0 \end{bmatrix} \begin{bmatrix} \hat{J}[k] \\ \rho[k] \end{bmatrix} \Delta t + \begin{bmatrix} \kappa_P I \\ 0 \end{bmatrix} y[k] \Delta t + \begin{bmatrix} I \\ 0 \end{bmatrix} \Delta y[k] \quad (18)$$

Example (Laplacian matrix)

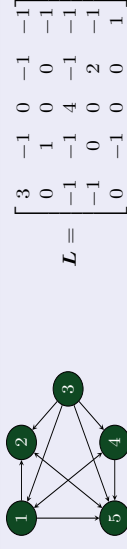

44 / 59

Controller design

Extremum seeking control (ESC)

- The objective of ESC is to minimize a measured cost
- Balloons estimate the gradient of the \widehat{J}_i with respect to u_i and move in that direction
- We will use the PI form of ESC:

$$u_i[k] = -k_g \widehat{\theta}_{1,i}[k] + \widehat{u}_i[k] + d_i[k] \quad (19)$$

$$\widehat{u}_i[k+1] = \widehat{u}_i[k] - \frac{1}{\tau_I} \widehat{\theta}_{1,i}[k] \quad (20)$$

- $\widehat{\theta}_{1,i}$ is the gradient estimate, k_g and τ_I are tuning parameters, and d_i is a dither signal
- Dither signals must all have different frequencies

45 / 59

Controller design

Single balloon block diagram

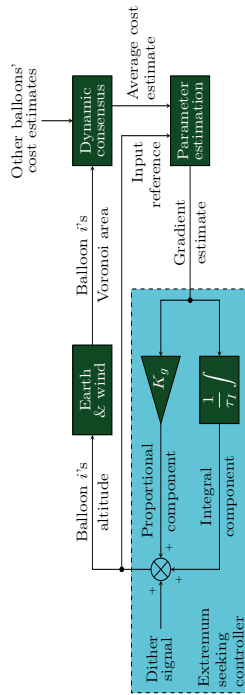

47 / 59

Controller design

Parameter estimation

- The total cost dynamics can be parameterized as:
- $$\frac{1}{p} \Delta J[k+1] = \theta_{0,i}[k] + \theta_{1,i}[k] u_i[k] = \boldsymbol{\theta}_i^T[k] \boldsymbol{\phi}_i[k] \quad (21)$$
- The parameter vector, $\boldsymbol{\theta}_i$, can be estimated using a variation of recursive least squares Adetola and Guay [2008]:

$$\boldsymbol{\Sigma}_i[k+1] = \alpha \boldsymbol{\Sigma}_i[k] + \boldsymbol{w}_i[k] \boldsymbol{w}_i^T[k] \quad (22)$$

$$\widehat{\boldsymbol{\theta}}_i[k+1] = \text{Proj}_{\gamma_0} \left(\widehat{\boldsymbol{\theta}}_i[k] + \frac{\boldsymbol{\Sigma}_i^{-1}[k] \boldsymbol{w}_i[k] (e_i[k] - \widehat{\eta}[k])}{\alpha + \boldsymbol{w}_i^T[k] \boldsymbol{\Sigma}_i^{-1}[k] \boldsymbol{w}_i[k]} \right) \quad (23)$$

46 / 59

Simulation results

Overview

- 1200 balloons floating between 10kPa and 1kPa (15–26 km altitude)
- Wind model is an interpolation of wind data on March 8, 2016 at 17:00 UTC from the NOAA National Oceanic and Atmospheric Administration [2016]
- Cost function depends on Voronoi area, A_i , and distance from centroid, $q_{c,i} \in \Gamma_i$

$$y_i = \left(A_i - \frac{A_i}{p} \right)^2 + \mathbb{G}(q_i, q_{c,i})^2 \quad (24)$$

- Each balloon communicates with its Delaunay-neighbours and implements identical discrete-time distributed ESC

Δt	κ_P	κ_I	K	α	τ_I	K_g	D	γ_0
0.1 h	1	0.5	0.8	10	1	0.1	1	

48 / 59

Simulation results

Launch sites

- Many balloons must all start at one of several launch sites
- For simulation, we have chosen 12 large cities around the world as launch sites



City	Country
New York	USA
Mexico City	Mexico
São Paulo	Brazil
Buenos Aires	Argentina
Paris	France
Moscow	Russia
Lagos	Nigeria
Kinshasa	DR Congo
Tokyo	Japan
Delhi	India
Jakarta	Indonesia
Manila	Philippines

Simulation results

Balloons without controllers launched from cities



49 / 59

Simulation results

ESC balloons launched from cities

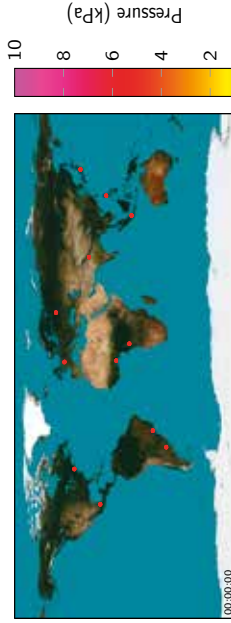

50 / 59

Simulation results

Cost function trajectories for balloons launched from cities

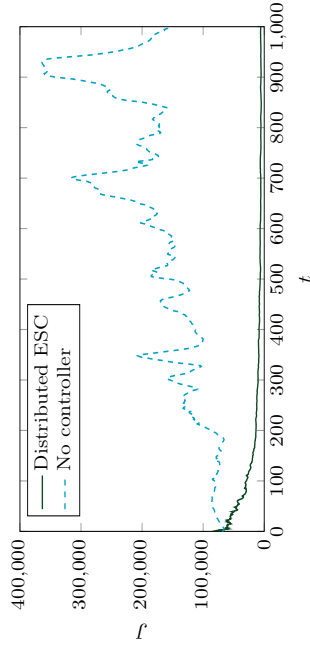

51 / 59

52 / 59

Concluding Remarks

Outlook

- ESC can be used to solve of number of problems where:
 - ▶ Exact mathematical nature of the input-output dynamics are unknown
 - ▶ Cost function can be measured or inferred
- Useful for the development of a wealth of new tools in PSE, Feedback stabilization
 - ▶ Observer design
 - ▶ Large scale system optimization
 - ▶ Systematic design of RTO systems
- Beyond existing techniques there are a wealth of new tools that are emerging:
 - ▶ ESC-based MPC
 - ▶ Machine Learning
 - ▶ Large optimization on clouds, etc...
- It is an adaptive, robust, real-time optimization technique with strong potential in many areas:
 - ▶ Automotive
 - ▶ Building Systems Management
 - ▶ Petroleum Production Technologies
 - ▶ Industrial energy management

53 / 59

Acknowledgements

The support of NSERC, OCE, Queen's University, Mitsubishi Electric Research Laboratory, Johnson Controls and Praxair is gratefully acknowledged.

55 / 59

Thank you.

54 / 59

56 / 59

Bibliography I

- V. Adicola and M. Guay. Finite-time parameter estimation in adaptive control of nonlinear systems. *IEEE Transactions on Automatic Control*, 53(3):807–811, 2008.
- Karik B Arıyar and Miroslav Krstic. *Real-time optimisation by extremum-seeking control*. Kluwer-Intelligence, 2006.
- Khalid Bouabdellah, Thomas Choukseyan, and Thomas Choukseyan. Extremum seeking control based on phasor estimation. *Systems & Control Letters*, 85:37–45, 2015.
- J.-Y. Choi, M. Krstic, K.B. Arıyar, and J.S. Lee. Extremum seeking control for discrete-time systems. *IEEE Trans. Autom. Contr.*, 47(2):318–323, 2002. ISSN 0018-9286. doi: 10.1109/9.983370.
- A. Chaffari, M. Krstic, and D. Nesic. Multivariable newton-based extremum seeking. *Automatica*, 48(8): 1769–1787, 2012.
- G.C. Goodwin and K.S. Sin. *Adaptive Filtering Prediction and Control*. Dover Publications, Incorporated, 2013. ISBN 9780486137728. URL http://books.google.ca/books?id=0_9j-v9M4EC.
- M Guay and T. Zhang. Adaptive extremum seeking control of nonlinear dynamic systems with parametric uncertainties. *Automatica*, 39(12):1283–1293, 2003.
- Martin Guay. A time-varying extremum-seeking control approach for discrete-time systems. *Journal of Process Control*, 24(3):98–112, 2014.
- Nick J Killingsworth and Miroslav Krstic. Pid tuning using extremum seeking: online, model-free and off-line. *Systems & Control Letters*, 96(1):70–79, 2006.
- M Krstic and H.H. Wang. Stability of extremum seeking feedback for general dynamic systems. *Automatica*, 36(4):595–601, 2000.
- M. Krstic, J. Kanellakopoulos, and P. Kokotovic. *Nonlinear and Adaptive Control Design*. Wiley: Toronto, 1995.
- M Leblanc. Sur l'électrification des chemins de fer au moyen de courants alternatifs de fréquence élevée. *Revue Générale de l'Électricité*, 1922.
- Wei Lin. Further results on global stabilization of discrete nonlinear systems. *Systems & Control Letters*, 29(1):51–59, 1996.

57 / 59

Bibliography III

- Y. Tan, D. Nesic, and I. Mareels. On non-local stability properties of extremum seeking control. *Automatica*, 42(6):889 – 903, 2006. ISSN 0005-1098. doi: 10.1016/j.automatica.2006.01.014.
- Y. Tan, W.H. Moase, C. Manzie, D. Nesic and, and L.M.Y. Mareels. Extremum seeking from 1922 to 2010. In *29th Chinese Control Conference (CCC)*, pages 14 – 26, July 2010.
- Andrew R Teel and Dobrivoje Popovic. Solving smooth and nonsmooth multivariable extremum seeking problems by the methods of nonlinear programming. In *Proceedings of the 2001 American Control Conference*, volume 3, pages 2394–2399. IEEE, 2001.
- Isaac Vandermeulen, Martin Guay, and P. James McLellan. Discrete-time distributed extremum-seeking control for nonlinear systems with unknown dynamics. In *10th IFAC Symposium on Nonlinear Control Systems (NOLCOS)*. IFAC, 2011.

59 / 59

Bibliography II

- Shu-Jun Liu and Miroslav Krstic. Newton-based stochastic extremum seeking. *Automatica*, 50(3):952 – 961, 2014a. ISSN 0005-1098. doi: <http://dx.doi.org/10.1016/j.automatica.2013.12.023>. URL <http://www.sciencedirect.com/science/article/pii/S0005109814000687>.
- Shu-Jun Liu and Miroslav Krstic. Discrete-time stochastic extremum seeking. In *Proc. IFAC World Congress*, volume 19, pages 3274–3279, 2014b.
- C. Manzie and M. Krstic. Extremum seeking with stochastic perturbations. *IEEE Trans. Autom. Contr.*, 54(3):580–585, 2009.
- William H Moase and Chris Manzie. Fast extremum-seeking for wiener-hammerstein plants. *Automatica*, 48(10):2433–2443, 2012.
- William H Moase, Chris Manzie, and Michael J Brer. Newton-like extremum-seeking for the control of thermodynamic instability. *IEEE Trans. Autom. Contr.*, 55(9):2094–2105, 2010.
- National Oceanic and Atmospheric Administration. NOAA operation model archive and distribution system, 2016. URL <http://nomads.ncep.noaa.gov/>.
- D. Nesic, T. Nguyen, Y. Tan, and C. Manzie. A non-gradient approach to global extremum seeking. An *Automatica*, 49(3):809 – 819, 2013. ISSN 0005-1098. doi: <http://www.sciencedirect.com/science/article/pii/S0005109812006036>.
- Official Google Blog. Introducing project loon: Balloon-powered internet access, 2013. URL <http://googleblog.blogspot.ca/2013/06/introducing-project-loon.html>.
- Robert J Renka. Algorithm 772: STRIPACK: Delaunay triangulation and voronoi diagram on the surface of a sphere. *ACM Transactions on Mathematical Software (TOMS)*, 23(3):416–434, 1997.
- John J Ryan and Jason L Speyer. Peak-seeking control using gradient and hessian estimates. In *American Control Conference (ACC)*, 2010, pages 611–616. IEEE, 2010.
- Adam C. Sneiderman, Mirielle E. Broucke, and Gabriele M. T. D'Elueterio. Formation control of balloons: A non-gradient approach. In *American Control Conference (ACC)*, 2015, pages 1463–1468. IEEE, 2015.

58 / 59

YI CAO

CRANFIELD UNIVERSITY

Recent Development on Global Self-Optimizing Control

Self-optimizing control (SOC) aims to select a set of controlled variables (CVs) for process plants subject to various uncertainties and disturbances such that when these CVs selected are controlled at constant set-points the corresponding plant operation is optimal or near optimal in terms of a predetermined economic objective. Comparing with standard real-time optimization (RTO) strategies, SOC is much simpler for implementation and does not suffer from long time waiting for steady-state convergence. Due to the feedback nature, SOC is much more robust comparing to the so called economic MPC solutions appearing recently.

Since SOC was proposed by Skogestad in 2000, most research works focused on linear model based solutions. Due to linearization, these solutions are only valid locally around the reference operating point, hence was refereed as local SOC. Recently, several approaches have been proposed to select CVs for the entire operation space. These methods are referred to global SOC (gSOC).

In the talk, the principles and algorithms of these gSOC approaches will be explained. It includes gradient regression based approaches, CV adaptation approaches, optimal operation data based approaches, subset measurement selection approach and retrofit SOC approach.

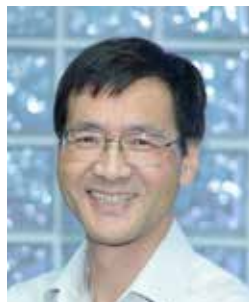



Recent Development of Global Self-Optimizing Control

Lingjian Ye, Yi Cao
 Ningbo Institute of Technology
 Cranfield University

LCCC Process Control Workshop
 23rd October 2016

www.cranfield.ac.uk

1



Outline

- Self-optimizing control (SOC) problem
- Brute force approach and local approaches
- Global self-optimizing control (gSOC)
 - Gradient regression approach
 - Controlled variable adaptation
 - Optimal data based approach
 - Subset measurement selection
- Retrofit SOC
- Case studies
- Conclusions

3



Cranfield University

- Location: "linear combination" of Cambridge
- Postgraduate only university
- University has an airport
- Industrial scale facilities

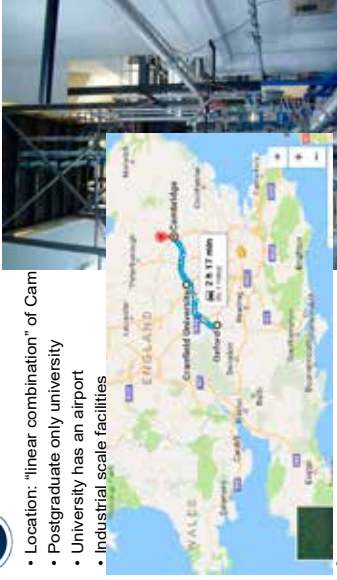

2



Self-optimizing control problem

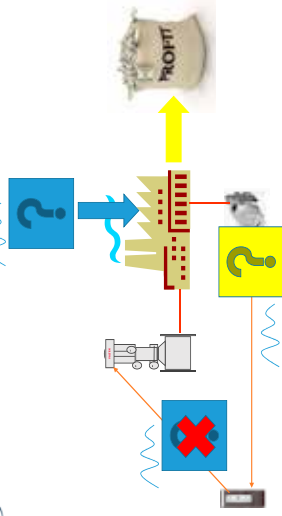

Relevant problems: **Inferential Control**, **Indirect Control**

4



Self-optimizing control problem

- Self-optimizing control (SOC): select controlled variables (CVs) offline such that when CVs are kept at constant online the corresponding operation is optimal or near optimal.
- Loss = actual cost – optimal cost
- Loss, L depends on CV, c and uncertainties, d and ε
- Worst case loss, $L_{WPC}(c) = \max_{d \in D, \varepsilon \in E} L(c, d, \varepsilon)$
- Average loss, $L_{AV}(c) = E_{d \in D, \varepsilon \in E} [L(c, d, \varepsilon)]$
- SOC: select CVs such that the corresponding loss is acceptable.
- Assume active constraints invariant for simplicity

5



Optimal CV selection approaches

- CVs can be individual measurements as well as linear or **nonlinear** measurement combinations, $c = Hy$.
- CV selection problem:

$$\min_H L, \text{ for } L = L_{WPC}(C), L_{AV}(C)$$

$$\text{s.t. } c = Hy = c_s, y = h(u, d, \varepsilon)$$
- **Brute force approach:** given H , evaluate L , then MINLP to solve H
- Non-convex, combinatorial, very complicated feedback evaluation
- Computationally intractable
- **Local approach:** Linearize around nominal point, $y = G_y u + G_d d + \varepsilon$
- $h_u = 0, L = 0.5u^T J_{uu} u + d^T J_{du} u + 0.5d^T J_{dd} d$
- Analytical solution available, but valid locally
- Loss is large when operation condition away from reference point

6



Global self-optimizing control (gSOC)

- Parametric selection by solving H
- Individual measurements, each row of H has only one 1, rest are 0
- Constant setpoint can be included, $c = c_s \rightarrow \xi = c - c_s = 0$
- Nonlinearity can be handled by $c = Hf(y)$
- Controller design can also be covered, $c = u - Hy = 0 \rightarrow u = Hy$
- Feedback as well as feedforward, $c = H_y y + H_d d$
- Cascade control, $u = h_0 + h_1 y_1 + h_2 y_2 = h_1 \begin{bmatrix} y_1 \\ y_2 \end{bmatrix} + \frac{h_0}{h_1} (y_2 + \frac{h_0}{h_1})$
- Dynamic problems, $y = [y_k^T \ y_{k-1}^T \ \dots \ y_{k-m}^T]^T$
- **Reconfigure control structure automatically**



Global self-optimizing control (gSOC)

- Can we have a tractable algorithm to solve CV selection problem globally?
- Solution: **model** → **data** → **solution**
- Loss due to measurement uncertainty can be decoupled from loss due to disturbances
- Collect global data through Monte Carlo simulation over entire operation region of disturbances
- Select optimal CV based on global data collected.

7

8



gSOC: gradient regression

- Best CV: gradient, J_{gr} , but unmeasurable
- Gradient regression, $\tilde{C} = Hy = J_{gr}$
- Loss due to regression error $\tilde{C} - J_{gr} = \epsilon$,
- $L = \frac{1}{2} \epsilon^T (J_{gr})^{-1} \epsilon \leq \frac{1}{2} M \|\epsilon\|_2^2$ with constant $M \geq \frac{1}{\lambda} J_{gr}^{-1}$
- **The smaller the approximation error, $\|\epsilon\|$, the smaller the loss, L .**
- **Issue:** data point far away from optimal may have negative impact, but is all point are close to optimal, the problem becomes singular.

9



gSOC: CV adaptation

- To avoid overfitting, simple CV function is preferable
- Simple CV may result in small region for acceptable performance
- Solution, update CV (adaptation) based on current operating point
- **Control system reconfiguration: CV, setpoint, and gain**

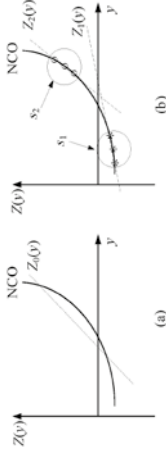

10



gSOC: data driven approach

- Collect data set: y_k, u_k, d_k and J_k for operation scenarios, $k = 1, \dots, N$
 - $J_{k+1} - J_k = \sum_{i=1}^n g_{i,k} (u_{i,k+1} - u_{i,k})$ pair for $d_{k+1} \approx d_k$
 - Replace $g_{i,k} = H_i Y_k, J_{k+1} - J_k = \sum_{i=1}^n H_i Y_k (u_{i,k+1} - u_{i,k})$
 - Regression: $Z = MH^T$
- $$Z = \begin{bmatrix} J_2 - J_1 \\ \vdots \\ J_N - J_{N-1} \end{bmatrix}, M = \begin{bmatrix} Y_1^T (u_{1,2} - u_{1,1}) & \dots & Y_1^T (u_{n,2} - u_{n,1}) \\ \vdots & \ddots & \vdots \\ Y_{N-1}^T (u_{1,N} - u_{1,N-1}) & \dots & Y_{N-1}^T (u_{n,N} - u_{n,N-1}) \end{bmatrix}$$
- Least squares solution:
 - $H = \begin{bmatrix} H_1 \\ \vdots \\ H_n \end{bmatrix} = M^+ Z$

11



gSOC: optimal CV and short cut approaches

- Evaluating loss against CV deviation around optimum simplifies solution.
- $L = \frac{1}{2} \Delta c^T J_{cc} \Delta c, \Delta c = c_{pb} - c^* = -c^* = -Hy^*$
- $J_{cc}^* = (\partial u / \partial c)^T J_{uu}^* \partial u / \partial c = (G^*)^{-T} J_{uu}^* G^*, G^* = HG_y^*$
- $L(H) = \frac{1}{2} y^{*T} H^T (G^*)^{-T} J_{uu}^* G^* Hy^*, L_{AV}(H) = \frac{1}{2N} \sum_{i=1}^N y_i^{*T} H^T G_i^{*-T} J_{uu,i}^* G_i^* Hy_i^*$
- To ensure uniqueness, introduce $J_{r,uu}^{*,1/2} = HG_{r,y}^*, s.t. J_{r,uu}^{*,1/2} = HG_{r,y}^*$
- Short-cut algorithm: $J_{i,cc} = I, \forall i \in [1, N]$, analytic solution available
- $\min_H \frac{1}{2N} \sum_{i=1}^N y_i^{*T} H^T Hy_i^*, s.t. J_{r,uu}^{*,1/2} = HG_{r,y}^*$
- Assume d and ϵ are independent, $L^{de} = L^d + L^\epsilon$
- $L_{AV}^\epsilon = \text{trace}(H^T W H)$, W the covariance of ϵ .

12



gSOC: subset selection

- Minimum loss independent from H for a given set of measurements
- Seek a small subset with similar performance but much simpler structure
- Branch and bound algorithms are developed to solve selection problems

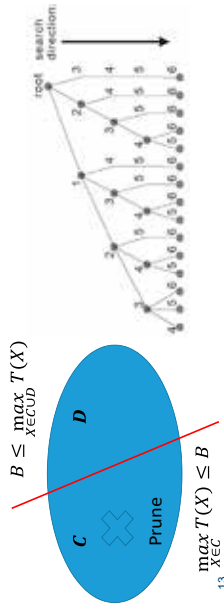

Toy Example

- Cost: $J = \frac{1}{2}(u - d)^2$;
- Measurements: $y_1 = u$; $y_2 = \frac{1}{4}u^2 + d$
- Nominal point: $d^* = 0$;
- Nominally optimal point: $f^* = u^* = y_1^* = y_2^* = 0$
- Local: $c_{local} = y_1 - y_2$; $L_{local} = 0.0183$
- Global: $c_1 = y_1 - 0.981y_2 + 0.0981$; $L_1 = 0.00375$
- Polynomial: $c_2 = y_1 - y_2 + 0.25y_1^2$; $L_2 = 0$



gSOC: retrofit SOC

- Do we need to redesign the entire control system for SOC?
- **Retrofit SOC:** control CVs selected by adjusting existing setpoints

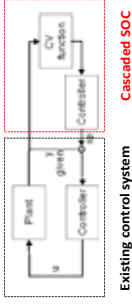

Advantages:

- Implementation does not need plant shut down
 - Dynamic performance and constraints handling inherited
 - gSOC to ensure best economic performance
 - Subset selection to ensure simplest control structure
 - Directly compatible with RTO
 - **Applicable to IoT**
- 14



Toy Example: NCO regression

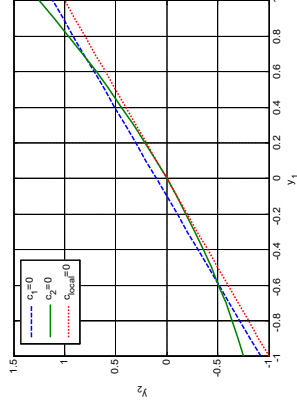



Toy example: optimal CV

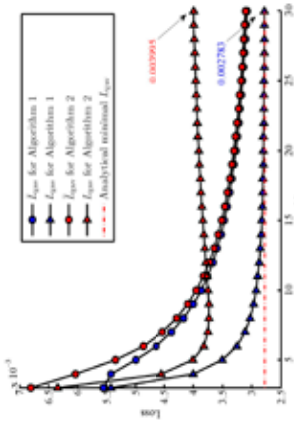

17



Retrofit SOC: TE Process

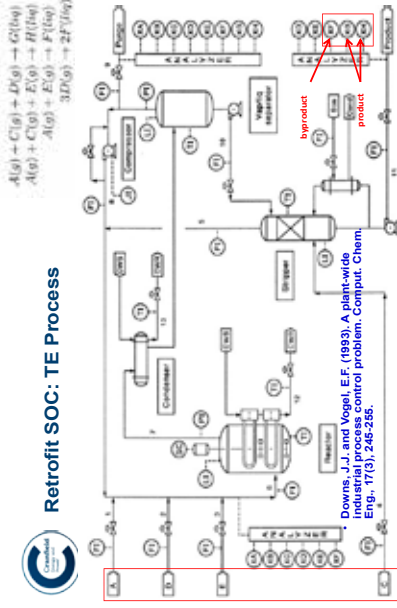

18



Retrofit SOC: operation optimization

- Economic objective: minimize the cost
- $J = (\text{loss of raw materials in purge and products}) + (\text{steam costs}) + (\text{compression costs})$
- Various Constraints:**
 - (1) Product mixup (ratio of G:H), production rate
 - (2) Reactor pressure, temperature
 - (3) Vessel levels
 - (4) MV saturations
 - (5) etc
- Degrees of freedom:
 - 9 active constants: XMEAS(7,8,12,15,17,19,40), XMV(5,9,12)
 - 3 DOF for SOC
 - Retrofit SOC adjust 3 set-points, y_A , y_{AC} and T_{rec}

19



Retrofit SOC: existing optimal control structures

1. Ricker, N. (1996), (CS_Ricker)
 - Nominal optimization + heuristic design
 - Decentralized control structure is available via <http://depts.washington.edu/control/LARRY/TE/download.html>
2. Larsson et. al. (2001), (CS_Skoje)
 - Individual measurement based SOC

20



Results and simulations

- 7 Operating conditions considered
 - nominal
 - IDV(1): A/C feed ratio
 - IDV(2): B composition
 - production rate $\pm 15\%$
 - product mix change: 50 G/50 H to 40 G/60 H
 - step change of reactor pressure set-point to 2645 kPa

21



Minimal loss against subset size

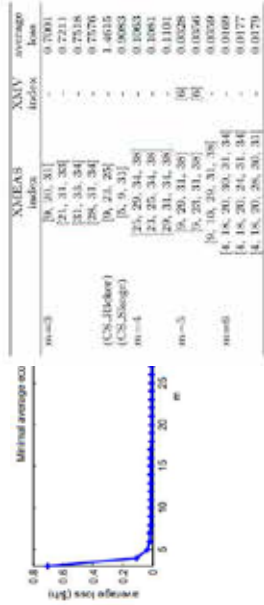

XMEAS(>=23) : compositions



Simulation and Result economic loss

	CS_Ricker	CS_Stage	This work (m=3)	This work (m=6)
Nominal	0	0	0.1	0.04
IDV(1)	0	0.03	0.2	0.05
IDV(2)	2.7	1.7	0.9	0
throughput +15%	6.1	1.5	2.4	0.05
throughput -15%	2.6	0.6	0.2	0.02
40 G/ 60 H	0.7	0.3	0.5	0.01
rct press 2645 kPa	0.3	4.5	1.3	0.01
sum	12.4	8.63	5.6	0.23

24



Conclusions and future works

- gSOC minimising loss over entire operation region
- Simulation data based approach, ready to use operation data directly
- Normal operation data: NCO regression
- RTO operation data: Optimal CV
- Three extensions: subset selection, adaptation and retrofit
- Future works
 - Nonlinear measurement combinations
 - Constrained SOC
 - Dynamic SOC
 - Reconfigurable SOC

STEVO MIJANOVIC

UNITED TECHNOLOGIES RESEARCH CENTER

Model-based Controls and Systems Engineering for Building and Aircraft Systems

Since its inception in 2010 UTRC Ireland has been focusing on developing, demonstrating, and transitioning to industrial practice model-based systems and controls engineering development processes and algorithms, in particular focused on building energy and security systems. More specifically, part of UTRC Ireland mission has been the development of Scalable, Intelligent, and Resilient building systems and in this talk we will illustrate a few such examples including the projects that have been carried out in collaboration with our university and industrial partners.

Since 2014 UTRC Ireland has also been focusing and developing model based systems engineering methods, processes, and tools for aerospace applications in particular focused on aircraft systems. In this talk we will illustrate some of these activities and projects.





United Technologies Research Center

Model-based Controls and Systems Engineering for Building and Aircraft Systems

Stevo Mijanovic, PhD
 General Manager
 United Technologies Research Centre Ireland

Lund University
 30 September 2016

OUTLINE

- UTC, UTRC, and UTRC Ireland
- UTRC Ireland Building Energy Research & selected projects
 - COOPERATE (EU co-funded FP7)
 - ELSA (EU co-funded H2020)
 - Energy in Time (EU co-funded FP7)
- UTRC Ireland Aerospace Research & selected project
 - MISSION (EU co-funded CS2)

United Technologies
Business units

Otis

Pratt & Whitney

UTC Climate, Controls & Security

UTC Aerospace Systems

2

UTRC IRELAND
Est. 2010 in Cork

Objectives...
 Hub for European interactions
 Leverage existing investments in ICT
 Treasord for energy and security technologies
 Support aerospace EU's

Highly skilled and diverse workforce

Technical capabilities and Groups

- Power Electronics & System Modeling
- Networks & Embedded Systems
- Decision Support

Leveraging national and EU network of innovation

- Insight - Centre for Data Analytics
- SFI - Research Centres
- Lero - Software Engineering Research Centre
- IDA Ireland
- Connect - Communication Networks Research Centre

3

4

UTRC IRELAND TECHNICAL CAPABILITIES

Controls & Decision support

- Thermal system modeling
- Model-based control design
- Model-predictive control
- Optimization-based control
- Fault detection and impact analysis
- Data- and physics-based diagnostics
- Video analytics

Power Electronics

- Hierarchical system modeling and controls
- Model-based power converter design
- Electric motor optimization
- Digital control of converters & drives
- Power quality analysis
- Grid estimation & emulation
- HLV/ rapid prototyping

Networks & Embedded Systems

- Sensor networks
- Communications protocols
- Model-based design
- Formal methods
- Embedded systems
- Software engineering
- Constraint programming

UTRC IRELAND ENERGY RESEARCH

Innovative solutions for system integration, monitoring and operation

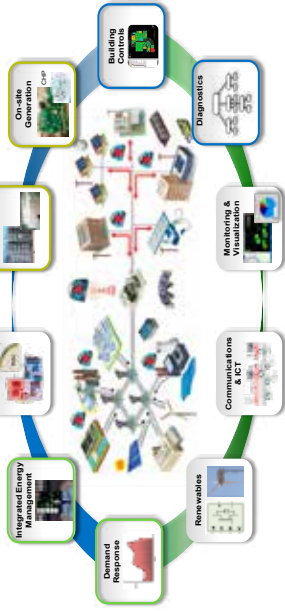

Developing key technology enablers for the new generation of energy services and products

This page contains no technical data and is not subject to the EAR or the ITAR.

FP7 COOPERATE

Control and optimization of energy positive neighbourhoods

Project Objectives

- Develop an open, scalable neighborhood energy management platform
- Services-oriented architecture for developing neighborhood energy services
- District-level energy optimization and decision support algorithms

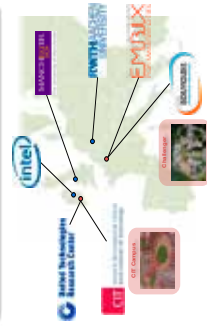

COOPERATE neighbourhood services and management platform



Key challenges:

- Distributed, heterogeneous multi-energy systems and loads
- Integration of heterogeneous thermal and electrical systems
- Integration of loads, embedded generation and storage
- Requires a System-Of-Systems (SoS) approach

FP7 COOPERATE

Hierarchical approach to neighbourhood energy optimization developed

Hierarchical Optimization Approach

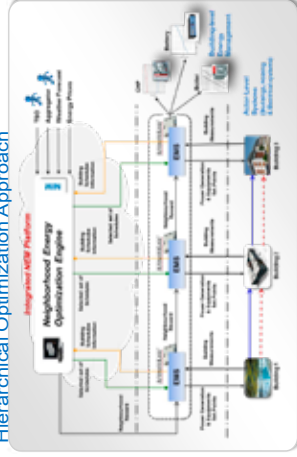

Objective:

- Reduce neighbourhood cost/emissions
- Multi-site supply, demand and storage optimization
- Coordinate generation and demand from different buildings

Challenges:

- Balance building and neighbourhood objectives (cost, emissions)
- Limited data available or disclosed in multi-owner districts
- Variable or real-time energy prices

Exploit flexibility at building equipment and loads to reduce overall neighbourhood cost and maximize RES and storage use

BISHOPSTOWN CAMPUS DEMO

In-field demonstration completed (February 15th-17th, 2015)

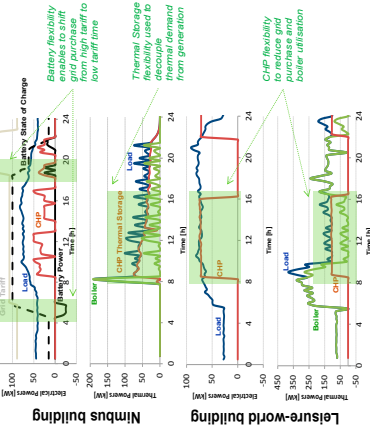

CIT Campus Demosite



- ✓ Coordinate electrical, thermal storage and local generation to minimize total energy cost (electricity + natural gas)
- ✓ 11% light energy consumption reduction by using battery and CHP flexibility.
- ✓ Optimal battery operation: charge at low tariff and discharge at high tariff
- ✓ Additional savings from local CHP generation (exploit low gas vs grid tariffs)

H2020 ELSA

Energy Local Storage Advanced system

- Bring electricity storage system based on electric vehicle used Batteries (in batteries) Building Energy Management System (BEMS) to an industrial level
- Pilot technology at 6 demo sites (France, UK, Spain, Italy and Germany)

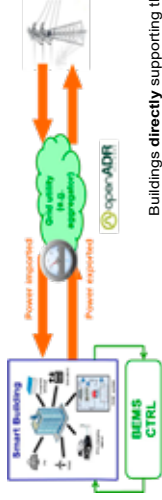

Buildings **directly** supporting the grid: **active role**
Buildings communicating **flexibility**
openADR allows for automated demand response services
BEMS coordinates building operations **guaranteeing comfort**

H2020 ELSA

Energy Local Storage Advanced system



SASMI building at Gateshead College (UK)

(Real electrical building consumption available, PV generation simulated using Dynalos)

Use case 1: **demand response 1h flexibility**

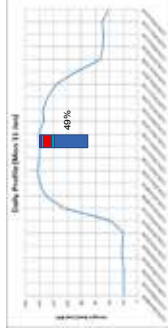

Battery, PV, 10% HVAC Reduction & Door Curtain
If grid requires, BEMS can coordinate batteries, PV and HVAC and can reduce the power consumption up to 49% for 1h event

Use case 2: **peak minimization**

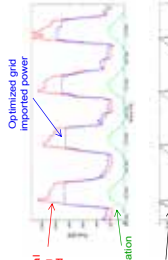

BEMS can coordinate loads, batteries and PV to reduce the peak consumption up to 16%



H2020 ELSA

Energy Local Storage Advanced system



SASMI building (UK)



X 3

Storage system capacity
1st life batteries: 72 kWh
2nd life batteries: 48 kWh

ENERGY IN TIME

Resilient and Intelligent HVAC Diagnostics and Control



AUTOMATED FAULT DETECTION AND DIAGNOSTICS

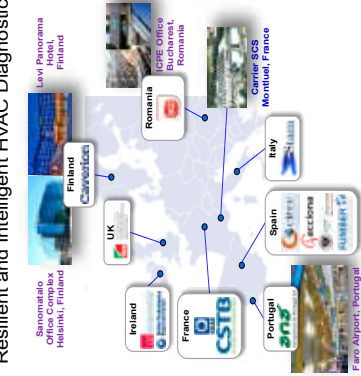

- UTRC Role**
- ❖ HVAC Fault Detection and Diagnostics
 - ❖ Efficient HVAC Commissioning
 - ❖ Advanced (MOD & FAC) Control
 - ❖ Field demonstration in Carrier
- Montluel, France.

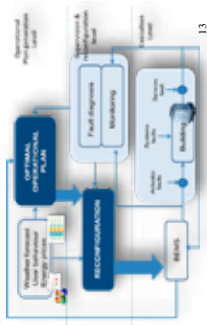

The Rationale

Hybrid Physics and Data Based Technology

Real Time Health Monitoring

Automated Commissioning & On Demand Building Health Analyse

UTRC IRELAND – AEROSPACE PROGRAMS

Developing methods and tools for integration of complex aerospace systems

Centre of Excellence in Cyber-Physical Systems for Aerospace

Modelling and Simulation Tools for Systems Integration on Aircraft

MISSION

- Modelling and simulation environment
- Aircraft-level design and optimisation
- System-level design and optimisation
- Model-based management & control
- Virtual testing

UTRC Ireland & ALES Partnering with: IDA Ireland, Clean Sky, dSPACE

GUY DUMONT

UNIVERSITY OF BRITISH COLUMBIA

Recent advances in paper machine control

A paper machine is a large scale complex process that transforms a very dilute fibre suspension into a sheet of paper with exacting specifications at speeds sometimes exceeding 120km/h. The direction in which the paper sheet travels is defined as machine direction (MD) and the direction perpendicular to the sheet travel is defined as the cross direction (CD). The control of the sheet's properties in both directions has been the subject of extensive development for the last five decades or so. In order to further improve the performance of those systems, there is currently a push to develop methods to automatically detect the cause of performance deterioration of model-based paper machine control system, both for the MD and CD processes. This paper will review some of those recent developments.





Recent Advances in Paper Machine Control

Q. Lu¹, M.G. Forbes², R.B. Gopaluni¹, P.D. Loewen¹, J.U. Backström², **G.A. Dumont¹**

1 - University of British Columbia 2 - Honeywell Process Solutions
Vancouver, Canada

LCCC Process Control Workshop – Lund - September 30, 2016



My Research Lab then....



16-10-14

3

Honeywell

Research Interests



- Adaptive Control, predictive control, system identification, control of distributed parameter systems, control performance monitoring.
- Applications of advanced control to process industries, particularly **pulp and paper**:
 - Kamyrdigester
 - Bleach plant
 - Thermomechanical pulping
 - **Paper machine**.

16-10-14

2

Honeywell



Research Interests



- Biomedical applications of control and signal processing:
 - Automatic drug delivery, closed-loop control of **anesthesia**,
 - Physiological monitoring in the OR and ICU, modeling and circadian rhythms),
 - Identification of physiological systems (cardiovascular system, EEG, ECG, etc...), detection of epileptic seizures,
 - Identification of the dynamics of the autonomic nervous system,
 - Low-cost mobile health technology for **global health**

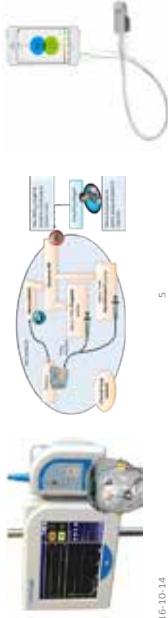

16-10-14

5

Back to the Paper Machine



- We have been collaborating with Honeywell Process Solutions since 1986

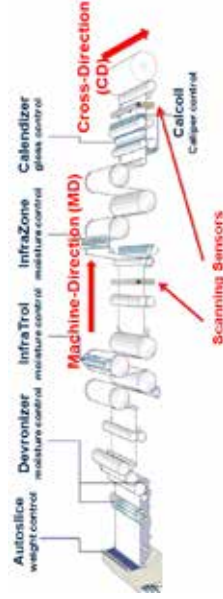

16-10-14

7

Honeywell

My Research Lab now...

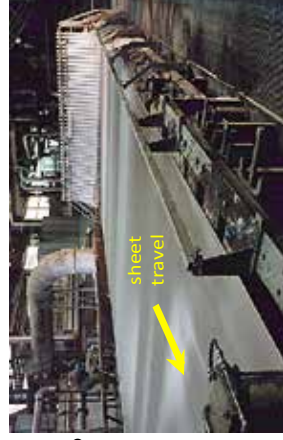

- Pulp stock is extruded on to a wire screen up to 11m wide and may travel faster than 100km/h.

Initially, the pulp stock is composed of about 99.5% water and 0.5% fibres.

8

16-10-14

Honeywell



- Newly-formed paper sheet is pressed and further de-watered.



suction presses

16-10-14

9

Honeywell



scanner

- The finished paper sheet is wound up on the reel.



The moisture content at the dry end is about 5%. It began as pulp stock composed of about 99.5% water.

16-10-14

11

Honeywell



finished reel



- The pressed sheet is then dried to moisture specifications

The paper machine pictured is 200 metres long and the paper sheet travels over 400 metres.

16-10-14

10

Honeywell



Outline

- Introduction
- Adaptive control for the MD process
- Adaptive control for the CD process
- Summary

12

16-10-14

Honeywell

Motivations



- For most paper machines, the initial controller is used for months even years without retuning the controller.
- Dynamics of paper machines vary over time due to changes in operation conditions.
- Control performance may deteriorate due to some factors, e.g., irregular disturbance, model-plant mismatch.

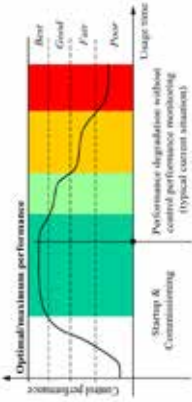

Control performance vs. usage time (M. Jellali, Springer, 2013)

16-10-14

13

Honeywell



Adaptive Control Framework

- Adaptive control scheme for both MD and CD

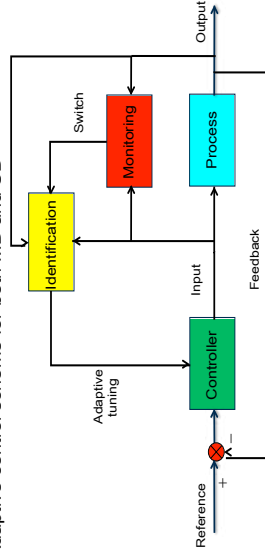

- Monitoring includes **control performance assessment** and **model-plant mismatch detection**.

16-10-14

15

Honeywell

Objectives



- Monitoring controller performance online for MD and CD processes.
- Identifying whether model-plant mismatch happens.
- Re-identifying process model in the case of significant mismatch:
 - Optimal input design in closed-loop;
 - Closed-loop identification.
- Re-tuning controllers based on updated process model.
- Performing this adaptive scheme in closed-loop without interrupting the process or user intervention.

16-10-14

14

Honeywell



Adaptive Control for the Machine-Directional Process of Paper Machines

16

Honeywell



Outline

- Performance monitoring
- Model-plant mismatch detection
- Optimal input design
- Summary



Performance Monitoring

- Minimum variance benchmark: time-delay as the main performance limitation.
- Decompose output into controller-invariant and controller-dependent

$$y(t) = \underbrace{f_0 e(t) + f_1 e(t-1) + \dots + f_{d-1} e(t-d+1)}_{F(q^{-1}) \text{ controller-invariant}} + R(z^{-1})e(t-d)$$

- MVC performance index

$$\eta = \frac{\text{var}[Fe(t)]}{\text{var}[y(t)]}$$

- Moving average modeling of $y(t)$ to estimate performance index.

16-10-14

17

16-10-14

18

Honeywell



Performance Monitoring Example

- Introduce a gain mismatch at time $t=300$ min

Pitfalls of using MVC or MVC-like benchmark to detect mismatch:

- Various factors can degrade performance index;
- Not able to discriminate mismatch from other causes;
- Noise model change can degrade PI but should not trigger an identification.

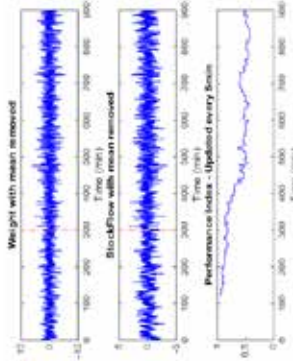

16-10-14

19

16-10-14

20

Honeywell



Model-Plant Mismatch Detection

- Mismatch detection is the **core** of our adaptive control scheme.
- **Objective**: a method to directly detect mismatch online, with routine operating data that may lack any external excitations.
- **Difficulty**: large variance on parameter estimates; limited amount of data.
- **Idea**: using a period of 'good data' as benchmark and compare it with the data under test.
- **Techniques**: a novel consistent closed-loop identification method; train support vector machine (SVM) with 'good data'; predict mismatch with SVM on testing data.

16-10-14

19

16-10-14

20

Honeywell



Model-Plant Mismatch Detection

- The training and testing idea:

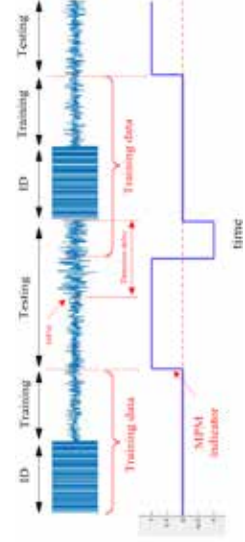

- MPM indicator: +1 means no mismatch; -1 means mismatch; 0 means SVM is under training.
- Actual algorithm works in moving window form.

16-10-14

Honeywell



SVM Training and Testing

- Illustration of SVM training and testing idea

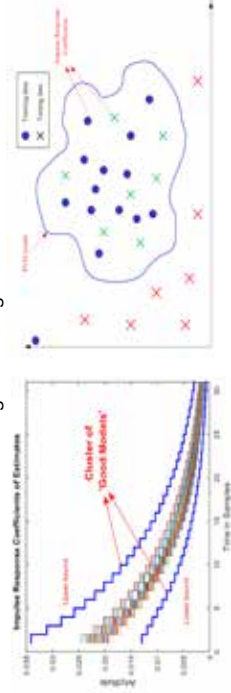

Cluster of impulse responses of process model estimates from 'good data'

Mismatch detection is viewed as 'outlier detection'

- Can monitor MPM and noise change independently.

16-10-14

Honeywell



Model-Plant Mismatch Detection

- Mismatch detection logic flow

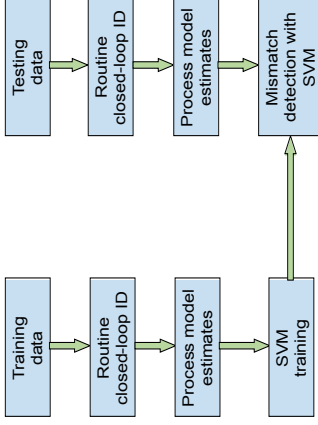

16-10-14

Honeywell



Mismatch Detection Example

- 3x3 lower triangular MD process with 3 MVs: steam3, steam4, steam5, and 3 CVs: weight, press moisture and real moisture.

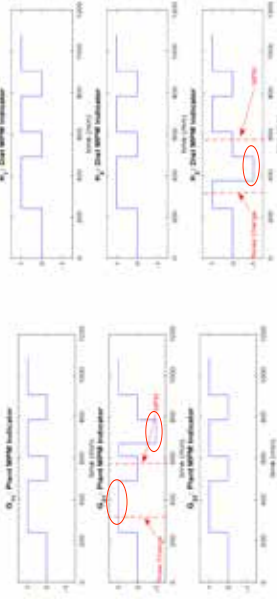

16-10-14

Honeywell



Optimal Input Design

- For ARX model structure

$$A(q^{-1}, \theta)y(t) = B(q^{-1}, \theta)u(t - d) + \epsilon(t)$$

- Covariance of parameter estimate $\hat{\theta}$ is

$$\text{cov}(\hat{\theta}) = (\Psi^T \Psi)^{-1} = R_u^{-1}$$

where Ψ is the regression matrix.

- Optimal input design is formulated as minimizing R_u^{-1} , or maximizing R_u , by choosing input signal

$$\max_u \text{trace}(R_u)$$

- It is shown that $R_u = U^T G U$, where U contains input signal, G is determined by process model information. The input design

$$\max_u \text{trace}(R_u)$$

$$\text{s. t. } u_t \in \mathcal{U}, y_t \in \mathcal{Y}, \quad t = 1, \dots, N$$

16-10-14

25

Honeywell



Optimal Input Design Example

- 2x2 lower triangular MD process, 2 CVs: dry weight, size press moisture, and 2 MVs: stock flow, dryer pressure

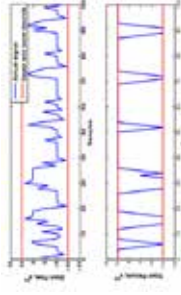

The designed excitation signal

16-10-14

27

Honeywell



Moving Horizon Input Design

- Input design requires true parameter values that are not available.
- Cannot guarantee input and output within bounds due to the difference between initial and true parameter values.
- Moving horizon input design framework

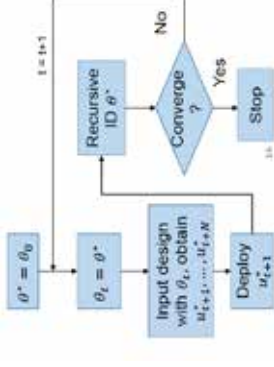

16-10-14

Honeywell



Optimal Input Design Example

- 2x2 lower triangular MD process, 2 CVs: dry weight, size press moisture, and 2 MVs: stock flow, dryer pressure

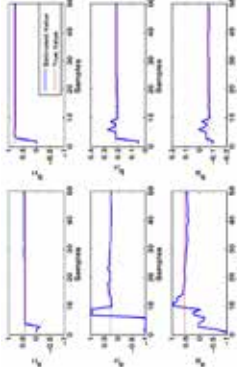

Recursive estimation of parameters

28

16-10-14

Honeywell



Summary

- Implemented the MVC benchmark to monitor controller performance for the MD process.
- Presented a novel closed-loop identification that can give consistent estimate for process model without requiring a *priori* knowledge on noise model,
- Proposed an SVM-based approach that can effectively detect mismatch and is not affected by noise model change.
- Designed an optimal input design scheme by maximizing the Fisher information matrix subject to a set of constraints on process input and output.

16-10-14

29

Honeywell



Outline

- CD process model and control
- Performance monitoring strategy
- Model-plant mismatch detection
- CD closed-loop input design
- Summary

16-10-14

31

Honeywell



Adaptive Control for the Cross-Directional Process of Paper Machines

16-10-14

30

Honeywell



CD Process Control

- Objective: keep paper sheet properties as flat as possible

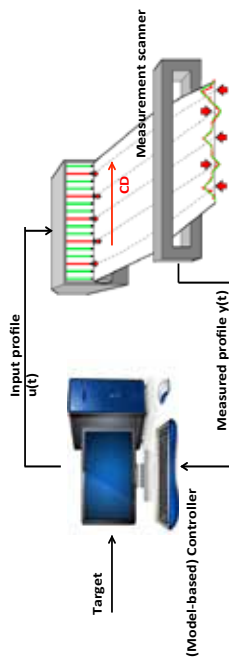

32

Honeywell

CD Process Model

- Only consider the single array case

$$y(t) = g(z^{-1})Cu(t) + H(z^{-1})e(t)$$
- Temporal parameter vector $\theta_T = [\gamma, d]$. Spatial parameter vector is collected into $\theta_S = [\gamma, \xi, \beta, \alpha]$.

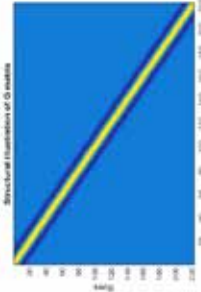
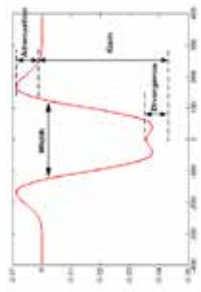

Single actuator spatial response

Structure of G matrix

16-10-14

33

Honeywell



Performance Monitoring Strategy

- A performance index (PI) to assess control performance:

$$PI = \frac{\text{trace}(\Sigma_{\text{benchmark}})}{\text{Trace}(\Sigma_{\text{output}})}$$

where $\Sigma_{\text{benchmark}}$ is the covariance of controller-invariant portion of output profile. Σ_{output} is the covariance of overall output profile.

- How to find controller-invariant parts from output profile?
 - Temporal direction: time-delay, unpredictable components;
 - Spatial direction: limited spatial bandwidth, uncontrollable parts.

Output Profile = Controller-dependent Part + Spatially-uncontrollable + Temporally-unpredictable

limited spatial bandwidth
temporal time-delay

16-10-14

35

Honeywell

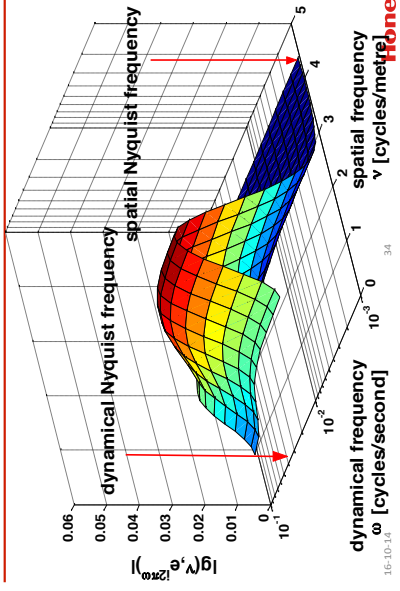

16-10-14

Honeywell



Performance Monitoring Strategy

- Precisely, decompose output profile $y(t)$ as:

$$y(t) = \underbrace{y_{loc}(t) + y_{pac}(t) + y_{sup,c}(t)}_{\text{controller-invariant}}$$

- Moving average (MA) form of controllable output profile

$$y_c(t) = \underbrace{f_0 e_c(t) + \dots + f_{d-1} e_c(t-d+1) + G_B(z^{-1}) e_c(t-d)}_{\text{unpredictable due to time-delay}}$$

- Performance index η is defined as

$$\eta = \frac{\text{trace}[\sum_{f=0}^{d-1} f \Sigma_{e_c} f^T]}{\text{trace}[\Sigma_{y_c}]}$$

16-10-14

36

Honeywell



Performance Monitoring Example

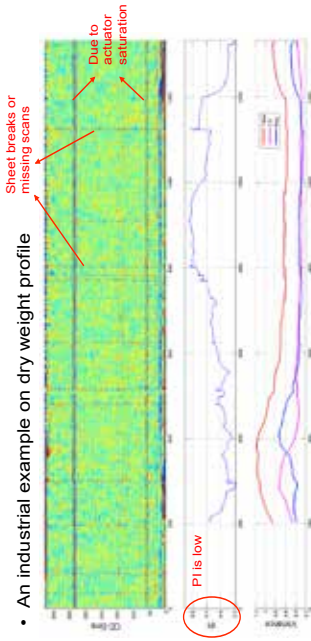

- An industrial example on dry weight profile
- Various factors may drop performance index.
- It is not easy to discriminate mismatch from other causes.
- We hope to detect the mismatch with routine operating data where external excitations may not exist.
- Extend the SVM technique to the CD process.



Model-Plant Mismatch Detection

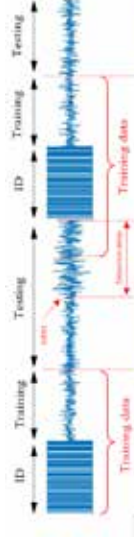

- Two main building blocks: **routine closed-loop ID** and **SVM tuning**.



Optimal Input Design in Closed-loop

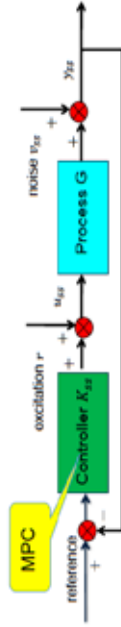

Fig. spatial input design scheme

- Focus on optimal input design for steady-state CD model G .
- Large number of inputs and outputs make it rather complex.
- Parsimonious noncausal modeling

$$y(x) = \frac{M(z)M(z^{-1})}{N(z)N(z^{-1})} r(x) + \frac{R(z)R(z^{-1})}{S(z)S(z^{-1})} e(x)$$



Optimal Input Design in Closed-loop

- Causal-equivalent representation

$$\hat{y}(x) = \frac{M^2(z^{-1})}{N^2(z^{-1})} r(x) + \frac{R^2(z^{-1})}{S^2(z^{-1})} e(x)$$

- Input design based on causal-equivalent representation

minimize $f(\Phi_{\sigma}^{-1}(\Phi_{\sigma}(\omega)))$

s. t. $\underline{u} \leq u(t) \leq \bar{u}$

$\underline{y} \leq y(t) \leq \bar{y}$

covariance matrix

power constraints

- Finite parameterization of spectrum $\Phi_{\sigma}(\omega)$ and reduce the problem into convex optimization.

Optimal Input Design in Closed-loop



- Comparison between optimal input, spatial bump perturbation and white noise input (same variance with optimal input).

- 100 Monte-Carlo simulations under three dither signals
- Closed-loop identification with data collected from every simulation
- Estimates under optimal input have smallest variance
- Estimates under bump perturbation have largest variance

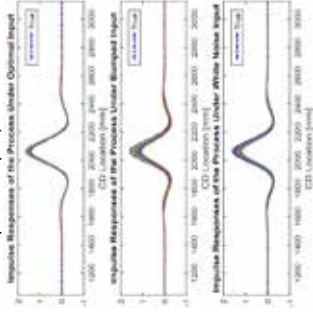

16-10-14

41

Honeywell



References - II

- Q. Lu, R.B. Gopaluni, M.G. Forbes, P.D. Loewen, J.U. Backstrom, and G.A. Dumont. Noncausal modeling and closed-loop optimal input design for cross-directional processes of paper machines. 2016.
- Q. Lu, L.D. Rippon, P.D. Loewen, R.B. Gopaluni. Adaptive control of paper machines. Technical report, 2016.
- M. Yousefi, Q. Lu, R.B. Gopaluni, P.D. Loewen, M.G. Forbes, G.A. Dumont, J.U. Backstrom. Detecting model-plant mismatch without external excitation. American Control Conference, 2015.
- M. Yousefi, L.D. Rippon, M.G. Forbes, R.B. Gopaluni, P.D. Loewen, G.A. Dumont, J.U. Backstrom. Moving-horizon predictive input design for closed-loop identification. AdChem, 2015.
- M. Yousefi, M.G. Forbes, R.B. Gopaluni, G.A. Dumont, J.U. Backstrom, A. Malhotra. Sensitivity of controller performance indices to model-plant mismatch: an application to paper machine control. American Control Conference, 2015.

16-10-14

43

Honeywell

References - I



- Q. Lu, M.G. Forbes, R.B. Gopaluni, P.D. Loewen, J.U. Backstrom, and G.A. Dumont. Performance assessment of cross-directional control for paper machines. IEEE Transactions on Control Systems Technology, 2016.
- Q. Lu, L.D. Rippon, R.B. Gopaluni, M.G. Forbes, P.D. Loewen, J.U. Backstrom, and G.A. Dumont. Cross-directional controller performance monitoring for paper machines. American Control Conference, 2015.
- Q. Lu, L.D. Rippon, R.B. Gopaluni, M.G. Forbes, P.D. Loewen, J.U. Backstrom, and G.A. Dumont. A closed-loop ARX output-error identification method for industrial routine operating data. 2016.
- Q. Lu, R.B. Gopaluni, M.G. Forbes, P.D. Loewen, J.U. Backstrom, and G.A. Dumont. Identification of symmetric noncausal processes: cross-directional response modeling in paper machines. 2016.
- Q. Lu, R.B. Gopaluni, M.G. Forbes, P.D. Loewen, J.U. Backstrom, and G.A. Dumont. Model-plant mismatch detection with support vector machines. 2016.

16-10-14

42

Honeywell

