



LUND UNIVERSITY

Carbon dioxide rebreathing with the anaesthetic conserving device, AnaConDa

Walther Sturesson, Louise; Malmkvist, Gunnar; Bodelsson, Mikael; Niklason, Lisbet; Jonson, Björn

Published in:
British Journal of Anaesthesia

DOI:
[10.1093/bja/aes102](https://doi.org/10.1093/bja/aes102)

2012

[Link to publication](#)

Citation for published version (APA):

Walther Sturesson, L., Malmkvist, G., Bodelsson, M., Niklason, L., & Jonson, B. (2012). Carbon dioxide rebreathing with the anaesthetic conserving device, AnaConDa. *British Journal of Anaesthesia*, 109(2), 279-283. <https://doi.org/10.1093/bja/aes102>

Total number of authors:
5

General rights

Unless other specific re-use rights are stated the following general rights apply:

Copyright and moral rights for the publications made accessible in the public portal are retained by the authors and/or other copyright owners and it is a condition of accessing publications that users recognise and abide by the legal requirements associated with these rights.

- Users may download and print one copy of any publication from the public portal for the purpose of private study or research.
- You may not further distribute the material or use it for any profit-making activity or commercial gain
- You may freely distribute the URL identifying the publication in the public portal

Read more about Creative commons licenses: <https://creativecommons.org/licenses/>

Take down policy

If you believe that this document breaches copyright please contact us providing details, and we will remove access to the work immediately and investigate your claim.

LUND UNIVERSITY

PO Box 117
221 00 Lund
+46 46-222 00 00

Carbon dioxide rebreathing with the anaesthetic conserving device, AnaConDa[®]. A laboratory study.

Louise Walther Sturesson¹, Gunnar Malmkvist¹, Mikael Bodelsson¹, Lisbet Niklason², Björn Jonson²

Sections of Anaesthesiology and Intensive Care¹ and Clinical Physiology², Department of Clinical Sciences Lund, Lund University and Skane University Hospital Lund, Sweden

Correspondence to: Louise Walther Sturesson, Department of Anaesthesiology and Intensive Care, Skane University Hospital Lund, SE-221 85 LUND, Sweden. Phone +46 46 171953.

Fax +46 46 176050. E-mail: louise.walther_sturesson@med.lu.se

Running head: Carbon dioxide rebreathing with AnaConDa[®].

Summary

Background: The anaesthetic conserving device (ACD), AnaConDa[®], was developed to allow the reduced use of inhaled agents by conserving exhaled agent and allowing rebreathing. Elevated $P_a\text{CO}_2$ have been observed in patients when using ACD, despite tidal volume compensation for the larger apparatus dead space. The aim of the present study was to determine whether CO_2 , like inhaled anaesthetics, adsorbs to the ACD during expiration and returns to the lung during the following inspiration.

Methods: The ACD was attached to an experimental test lung. Apparent dead space by the single-breath test for CO_2 and the amount of CO_2 adsorbed to the carbon filter of the ACD was measured with infrared spectrometry.

Results: Apparent dead space was 230 ml larger using the ACD compared with a conventional heat and moisture exchanger (internal volume 100 ml and 50 ml, respectively). Varying CO_2 flux to the test lung ($85 - 375 \text{ ml min}^{-1}$) did not change the measured dead space, nor did varying respiratory rate ($12 - 24 \text{ breaths min}^{-1}$). The ACD contained 3.3 times more CO_2 than the predicted amount present in its internal volume of 100 ml.

Conclusions: Our measurements show a CO_2 reservoir effect of 180 ml in excess of the ACD internal volume. This is due to adsorption of CO_2 in the ACD during expiration and the return of CO_2 during the following inspiration.

Key words: Airway - dead space; Anaesthetic techniques - inhalation; Carbon dioxide - rebreathing; Equipment - heat-moisture exchanger

Background

In the 1990s, an anaesthetic conserving device (ACD), AnaConDa[®] was developed to allow the reduced use of inhaled agents with open breathing circuits during anaesthesia; the ACD conserves exhaled agent and allows rebreathing.¹⁻³ The efficient use of inhaled sedation with the ACD to intensive care patients has been demonstrated.⁴ The ACD is a modified heat and moisture exchanger (HME) with an internal volume of approximately 100 ml. Elevated levels of $PaCO_2$ have been observed in patients when using the ACD, despite tidal volume increase to compensate for the larger apparatus dead space of the ACD compared with a conventional HME.⁵

The aim of this study was to test the hypothesis that the ACD retains CO_2 in a way analogous to the inhaled agents, and is returned to the lungs in the next inspiration. Such effects were studied using established methods to measure dead space after adjustments of tidal volume (V_T) and/or respiratory rate (RR) in a laboratory set-up using an artificial test lung.

Methods

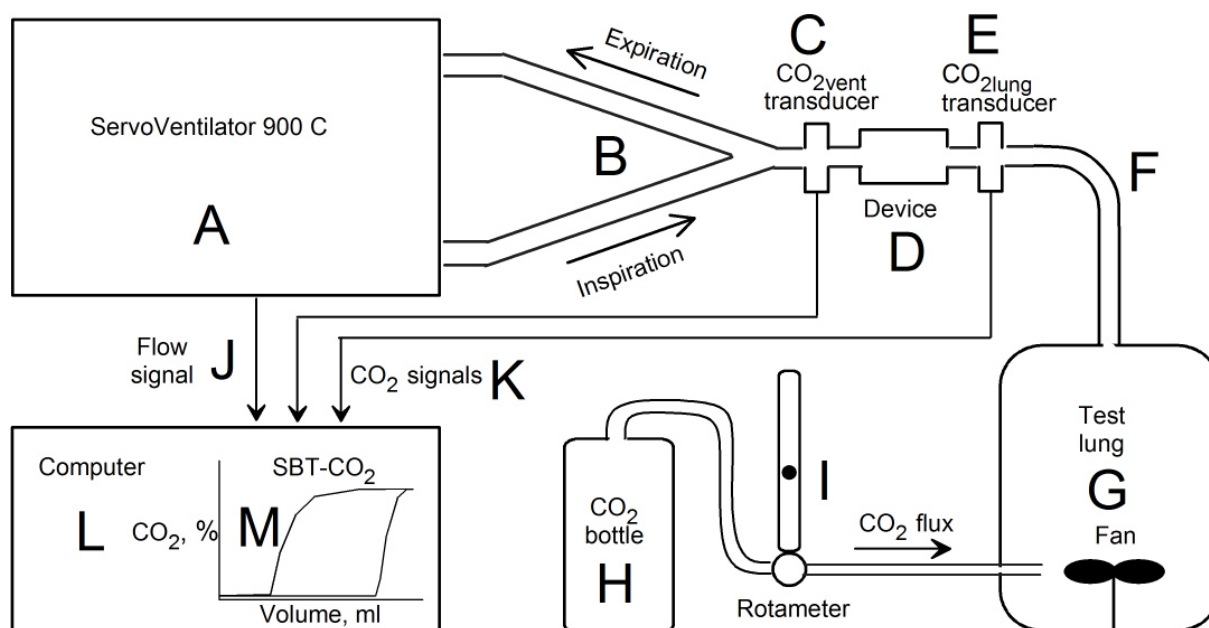

Fig 1 Experimental setup consisted of a ServoVentilator 900C (A), tubes to a Y-piece (B), a CO_2 transducer on ventilator side (CO_{2vent} , C), an HME/ACD (D), a CO_2 transducer on the lung side (CO_{2lung} , E), a connection tube to the experimental lung (F) and an experimental lung (G). CO_2 from a bottle (H) was fed through a rotameter (I), to the test lung. Signals for flow from the ventilator (J) and CO_2 signals from both CO_2 analyzers (K), were fed to a computer (L) and displayed on a screen (M).

The experimental set-up is shown in Fig. 1. A ServoVentilator 900C with two Analyzer 930 (Siemens-Elema AB, Solna, Sweden) mainstream CO_2 analysers ventilated a test lung in the form of a 20 litre plastic bottle with dry gas containing no anaesthetic agent. One of the CO_2 transducers (CO_{2vent}) was placed in the standard position between the Y-piece and the device tested, which in one single-run sequence was an HME (Vital Signs Inc., Totowa, NJ, USA), an in-active ACD in which there was no adsorbing filter and an active, off-the-shelf ACD. The second CO_2 transducer (CO_{2lung}) was placed between the device tested and the tube

connecting to the test lung. The purpose of the $\text{CO}_{2\text{lung}}$ transducer was to quantify the volume of CO_2 returned to the test lung according to the hypothesis.

The test lung was fed with pure CO_2 close to its bottom. The CO_2 flux, modelling metabolic rate in terms of CO_2 production, was adjusted and controlled by a precision rotameter between the CO_2 bottle and the test lung. Inside the test lung, gas was mixed by a fan. Ventilator flow rate and CO_2 signals from both analysers were fed to a personal computer, which sampled the signals at 100 Hz. A measurement sequence comprised 10 consecutive breaths. Data from each breath in the sequence were exported to an Excel spread sheet for compilation covering a full experiment. The previously described data collection system and subsequent data analysis yielding the single breath test for CO_2 (SBT- CO_2) was applied for each of the CO_2 analysers.⁶

7

Procedure

Starting with a conventional HME which has an internal volume of 50 ml, ventilator setting was: volume control $6.4 \text{ litre min}^{-1}$, RR $16 \text{ breaths min}^{-1}$ (i.e. V_T 400 ml), inspiratory time 25 %, postinspiratory pause 10 % and PEEP zero; RR was not changed during this experiment. The baseline CO_2 flux was set to 180 ml min^{-1} and was kept constant throughout the experiment. After approximately 30 minutes, steady state was observed with respect to CO_2 turnover as defined by the stable CO_2 -values for endtidal concentration and elimination from the test lung. At this point, two SBT- CO_2 measurement sequences were performed. Then, during a prolonged post-inspiratory pause, the connecting tube was clamped, the HME was exchanged for a in-active ACD, and V_T was increased by 50 ml to compensate for the volume difference between the HME and the ACD. SBT- CO_2 measurement sequences were performed when steady state again prevailed. Then, during a postinspiratory pause, the in-

active ACD was exchanged for an active ACD. When, as observed in pilot experiments, endtidal $\text{CO}_{2\text{vent}}$ approached the upper limit of the transducer range (10 %), V_T was increased stepwise.

In a second and third series of experiments, SBT- CO_2 measurements with active ACD:s were performed at steady state with varying CO_2 flux ($85 - 375 \text{ ml min}^{-1}$) and varying RR ($12 - 24 \text{ breaths min}^{-1}$), respectively. In the latter series tidal volume was adjusted, aiming at a steady state endtidal CO_2 of 5.0 %. In a fourth set, CO_2 content of one active ACD at various endtidal CO_2 -values was measured.

Data analysis

All recorded breaths were for each of the CO_2 -analysers were analysed for SBT- CO_2 (Fig. 2). Please note that the computed SBT- CO_2 of the CO_2 fraction vs. expired volume differs from the CO_2 fraction vs. time graph displayed on conventional capnographs. In Figure 2, expired flow increases the accumulated expired volume rightwards. During the following inspiration, flow is plotted negative and CO_2 decreases towards zero and thus completes the loop of the SBT- CO_2 plot of the breathing cycle. We assessed airway dead space (V_{Daw}) by determining the volume expired at the steepest increase in the CO_2 fraction during expiration.⁷ This method was chosen and validated for our test lung system, giving reproducible results as opposed to more commonly used alternatives designed for mammal lungs. The volume of CO_2 eliminated during a tidal breath ($V_T\text{CO}_2$) was determined from the area of the loop. The volume of CO_2 re-inspired at the start of inspiration ($V_I\text{CO}_2$) was determined from the area to the right of the loop.

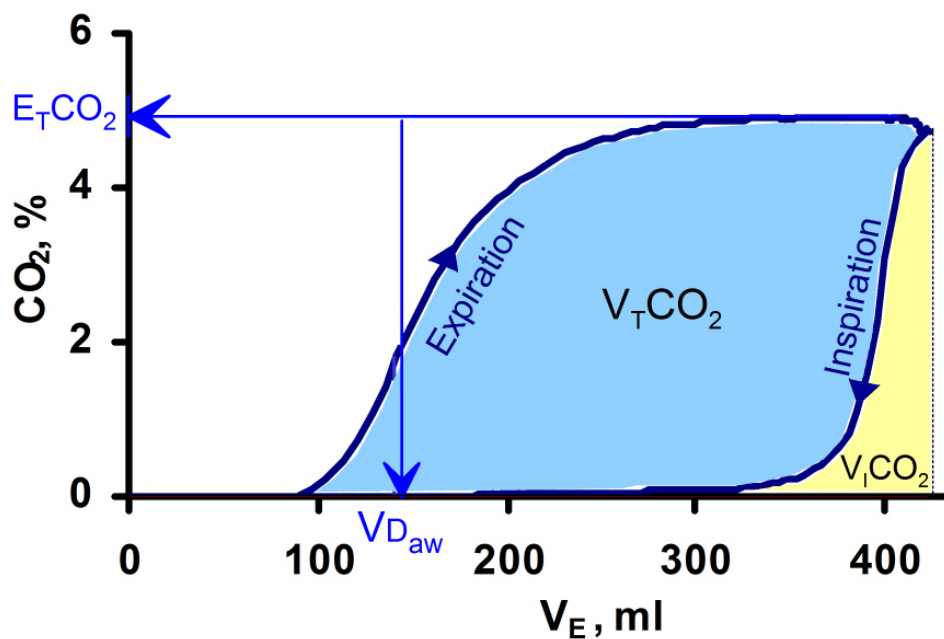

Fig 2 The single breath test for CO_2 displays expired tidal volume on the X-axis and CO_2 fraction, %, on the Y-axis. During expiration, CO_2 -free airway gas is expired first, followed by mixed airway and alveolar gas, and finally alveolar gas (alveolar plateau). Initially, during inspiration, CO_2 -containing gas from the Y-piece and ventilator tubing is re-inspired. The volume of re-inspired CO_2 ($V_I\text{CO}_2$) is represented by the yellow area. The blue area represents the volume of CO_2 eliminated during the breathing cycle ($V_T\text{CO}_2$). The volume of CO_2 expired during the breath corresponds to blue plus yellow areas ($V_T\text{CO}_2 + V_I\text{CO}_2$). Endtidal CO_2 ($E_T\text{CO}_2$) is indicated by the horizontal arrow and the airway dead space ($V_{D_{aw}}$) by the vertical arrow.

Results

Endtidal CO₂

At baseline with the HME, endtidal CO_{2vent} was stable at 5.0 - 5.1 %. When the HME was replaced by the in-active ACD and V_T increased by 50 ml, endtidal CO_{2vent} remained stable (Fig. 3). When the in-active ACD was replaced by the active ACD without any further increase in V_T, endtidal CO_{2vent} increased gradually, indicating accumulation of CO₂ in the test lung. When endtidal CO_{2vent} approached 10 % and V_T was increased stepwise endtidal CO_{2vent} declined (Fig. 3). When V_T was increased by 250 ml compared with baseline V_T with an HME, endtidal CO₂ returned to the baseline level. With a V_T 300 ml higher than baseline, endtidal CO₂ decreased below the baseline level.

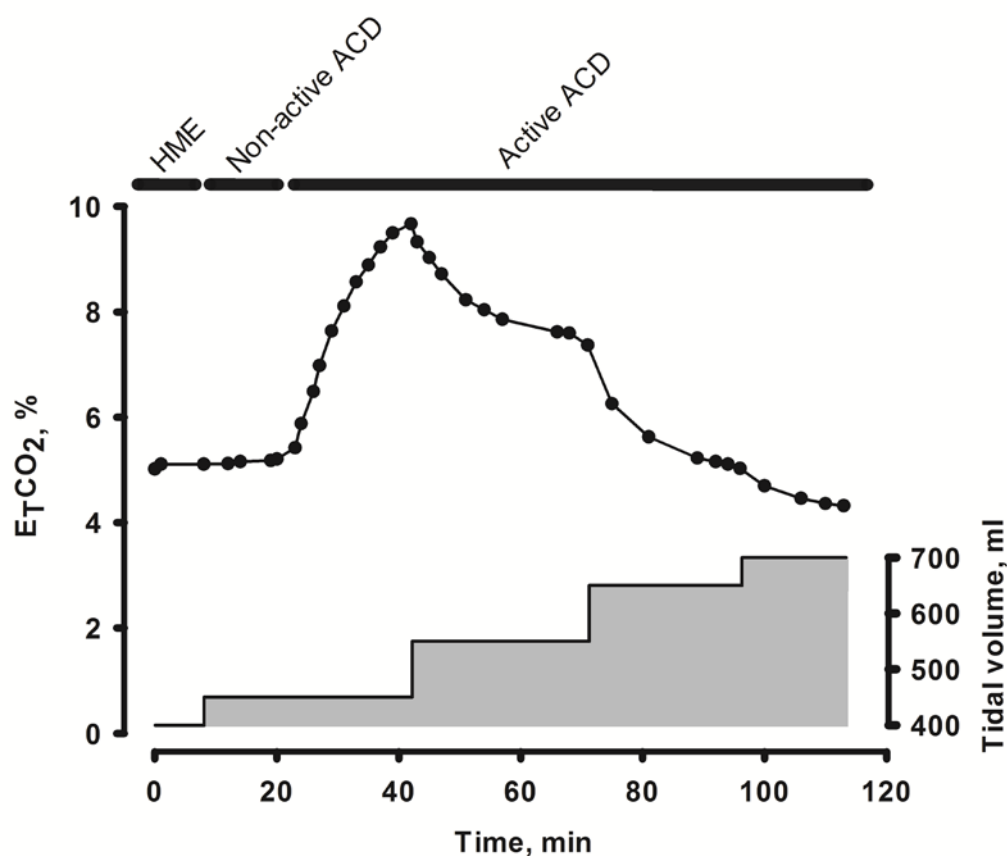

Fig 3 *Endtidal CO₂ (E_TCO₂) measured at the ventilator CO₂ transducer using an HME, inactive ACD and active ACD (upper curve). Tidal volume was increased by 50 ml corresponding to the difference in the internal volume between HME and ACD:s, when the inactive ACD was introduced (lower curve). When the active ACD had been introduced and E_TCO₂ approached 10 %, V_T was increased stepwise in order to restore the original value of E_TCO₂.*

Apparent V_{Daw} and CO₂ volumes

Figure 4 illustrates SBT-CO₂ from both CO₂ transducers with the HME and the active ACD, respectively. Tidal volume was adjusted to maintain isocapnia and steady state prevailed. SBT-CO₂ from CO_{2vent} (Fig. 4A) showed V_{Daw} values comprising the volume of the HME and tubing to the test lung (142 ml) and the volume of re-inspired CO₂ (V_ICO₂) from the Y-piece and adjacent tubes was 1.6 ml. SBT-CO₂ from CO_{2lung} (Fig. 4B) showed V_{Daw} values representing tubing only (101 ml), while V_ICO₂ included the volume of CO₂ in the HME and accordingly was higher (4.5 ml). When the ACD was studied with CO_{2vent} (Fig. 4C), no CO₂ appeared at the transducer until about 200 ml had been expired and V_{Daw} was estimated to 372 ml. V_ICO₂ was similar to breaths with conventional HME, as in Fig. 4A. When the ACD was studied with CO_{2lung}, CO₂ arrived rapidly at the CO_{2lung} transducer (Fig. 4D) and V_{Daw} was estimated to 113 ml. During inspiration, the fraction of inspired CO₂ remained high for about 200 ml and then gradually decreased towards zero as CO₂ washout from the ACD progressed. Of the total expired volume of CO₂ (13.3 + 15.5 ml), more than 50 % was re-inspired (15.5 ml). Varying CO₂ flux to the test lung between 85 and 375 ml min⁻¹ did not change the measured V_{Daw}. Varying RR between 12 and 24 breaths min⁻¹, with concomitant changes of tidal volume to maintain constant endtidal CO₂, also did not alter V_{Daw} (Table 1). The use of higher respiratory rate allowed lower tidal volumes to maintain isocapnia.

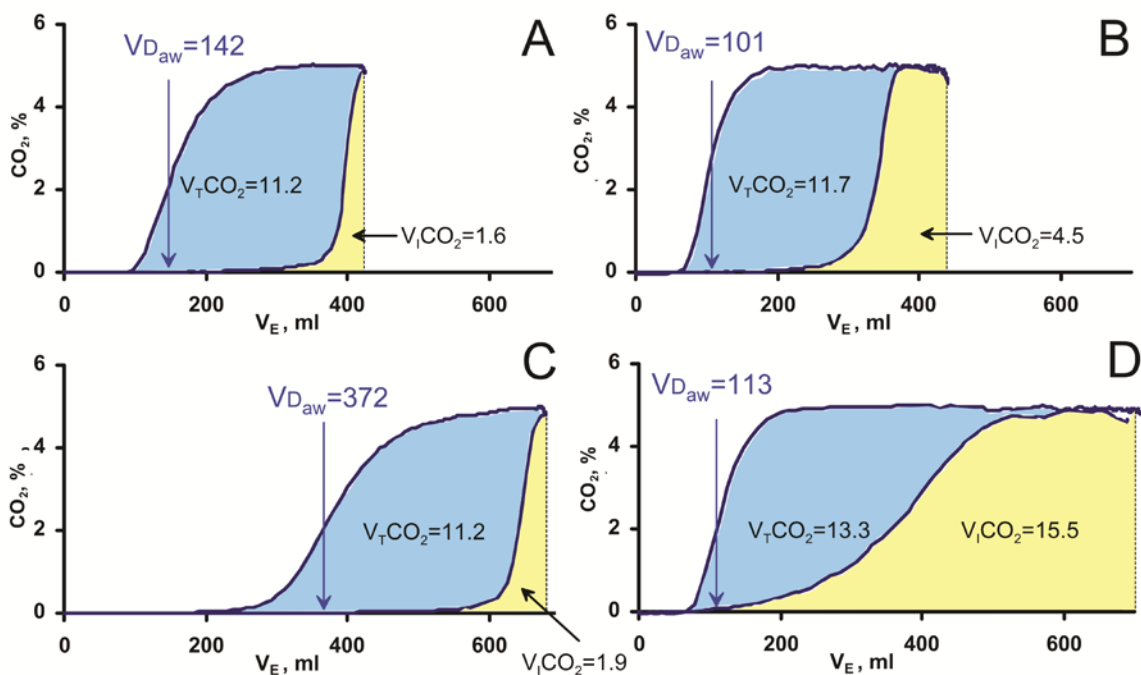

Fig 4 Single breath tests for CO_2 (SBT- CO_2) with an HME (A and B) or active ACD (C and D) registered on ventilator (A and C) or lung (B and D) side of the device, respectively. All volumes in millilitres. The volume of CO_2 eliminated during the breath ($V_T\text{CO}_2$, blue area) and inspired ($V_I\text{CO}_2$, yellow area) is indicated. Apparent airway dead space ($V_{D_{aw}}$) is indicated by the vertical arrow. SBT- CO_2 was studied after adjustment of tidal volume to maintain isocapnia and in steady state with respect to CO_2 elimination. As illustrated in panel C, the effect of the ACD is analogous to a large increase in $V_{D_{aw}}$ observed on the ventilator side of the device. In panel D this is reflected by the yellow area, representing a large volume of re-inspired CO_2 from the ACD.

Table 1 Tidal volume (V_T), steady state endtidal CO_2 , and apparent dead space (V_{Daw}) at different respiratory rates (RR) with an active ACD.

<i>Respiratory</i>	<i>Tidal volume</i>	<i>Endtidal CO_2</i>	<i>Apparent dead</i>
<i>rate (min^{-1})</i>	<i>(ml)</i>	<i>(%)</i>	<i>space (ml)</i>
12	760	5.1	372
16	676	5.1	370
20	603	5.2	364
24	560	5.3	372

ACD CO_2 content

Steady state endtidal CO_2 values between 1 % and 8 % were achieved by modifying the CO_2 flux. The volume of CO_2 retained in the active ACD, V_{CO_2ACD} , was measured with the CO_{2lung} transducer after disconnection of the test lung during a post-expiratory pause. During the first breath 95 % of this volume was washed out and after four breaths all detectable CO_2 had been eliminated. A strict proportionality between the V_{CO_2ACD} and E_TCO_2 was found: $V_{CO_2ACD} = 3.3 \times E_TCO_2$ ($R^2 = 0.99$, Fig. 5). Thus, the active ACD contained 3.3 times more CO_2 than the predicted amount present in its 100 ml of gas.

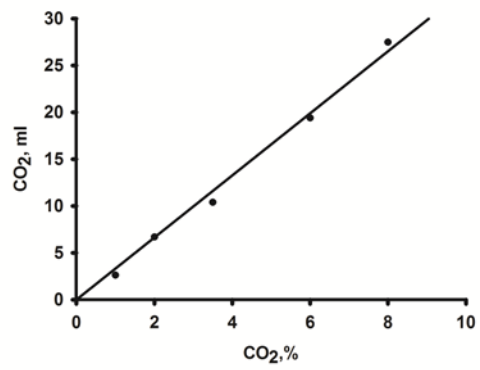

Fig 5 Amount of CO₂ in millilitres eliminated from the active ACD at different CO₂-fractions.

Discussion

The present investigation was performed in a laboratory setting in order to allow studies which cannot be done in animal or man, by allowing wide ranges of V_T , respiratory rate and CO_2 .

Our measurements consistently showed that the introduction of an active ACD was associated with a CO_2 -free expirate equivalent to an airway dead space increase exceeding the internal volume of the device by 180 ml regardless of the CO_2 flux or respiratory rate. Furthermore, we found a substantially increased volume of re-inspired CO_2 when using the active ACD. The hypothesis was thus confirmed; CO_2 is adsorbed by the ACD during expiration and returned to the lung during inspiration. The rapid washout of CO_2 adsorbed in the device shows that CO_2 is present only in a single fast compartment. The linearity of the relationship between end-tidal CO_2 and CO_2 volume retained in the active ACD implies that the device is not saturated even at a CO_2 concentration of 8 %. It can therefore be concluded that the active ACD has a high CO_2 -binding capacity, the upper limit of which was not explored.

These results agree with our observations in patients⁵ that isocapnia is not maintained by merely increasing V_T with the extra internal volume of the active ACD. In that study, the mean $PaCO_2$ was 1.1-1.4 kPa higher in patients where the ACD was used, and we suggested caution whenever using the ACD in situations where tight $PaCO_2$ control is necessary. Thus, endtidal CO_2 was only moderately increased compared with the present results. In the present study, applying such tidal volume compensation, endtidal CO_2 increased from 5 % to at least 10 %. This data may indicate that the dead space effect of the ACD in patients is less than in the present laboratory setting. A steady state is not quite achieved in patients within 30 minutes due to the large volume of exchangeable CO_2 stored in the body.⁸ This may to some

extent explain the difference between the degrees of CO₂ retention observed in the two studies. Tentative reasons for the seemingly different behaviour of the ACD in the present study are that in the present study humidity was zero, the temperature was that of the room and that no inhaled anaesthetic was used. This may also explain why CO₂ retention has not been addressed as a significant problem in previous reports on the clinical use of the ACD.²⁻⁴

We explored the effects of V_T and RR on CO₂ elimination in this laboratory model. Increasing V_T was effective in restoring endtidal CO₂ after introduction of the ACD. Somewhat shorter postoperative time to extubation when using smaller tidal volumes has recently been demonstrated in cardiac surgery patients suggesting a possibly negative effect of large volumes.⁹ If the findings in the present study are representative of effects in the clinical use of the ACD, it will be important to recognize risks associated with large tidal volumes. On the other hand, using higher respiratory rate allowed lower tidal volumes to maintain isocapnia in our test lung. If this also applies to the mammal respiratory system, increasing respiratory rate could be a possible strategy for compensating impaired CO₂ excretion induced by the use of an ACD.

In conclusion, we have demonstrated that the ACD adsorbs large amounts of exhaled CO₂ which is returned during the next inhalation creating a dead space effect. Further studies on factors which modify this effect are required before our results can be allowed to modify clinical practice.

Acknowledgements

The authors are grateful to Björn Drefeldt for excellent technical assistance.

Declaration of interests

The authors wish to acknowledge the generous supply of in-active ACD:s by Sedana Medical AB, Uppsala, Sweden. There was no other conflict of interests.

Funding

This work was supported by the Swedish Heart-Lung Foundation and Skane County Research Council.

List of references

1. Perhag L, Reinstrup P, Thomasson R, Werner O. The Reflector: a new method for saving anaesthetic vapours. *Br J Anaesth* 2000; **85**: 482-6
2. Enlund M, Lambert H, Wiklund L. The sevoflurane saving capacity of a new anaesthetic agent conserving device compared with a low flow circle system. *Acta Anaesthesiol Scand* 2002; **46**: 506-11
3. Tempia A, Olivei MC, Calza E, et al. The anesthetic conserving device compared with conventional circle system used under different flow conditions for inhaled anesthesia. *Anesth Analg* 2003; **96**: 1056-61
4. Sackey PV, Martling CR, Granath F, Radell PJ. Prolonged isoflurane sedation of intensive care unit patients with the Anesthetic Conserving Device. *Crit Care Med* 2004; **32**: 2241-6
5. Sturesson LW, Johansson A, Bodelsson M, Malmkvist G. Wash-in kinetics for sevoflurane using a disposable delivery system (AnaConDa) in cardiac surgery patients. *Br J Anaesth* 2009; **102**: 470-6
6. Aboab J, Niklason L, Uttman L, Kouatchet A, Brochard L, Jonson B. CO₂ elimination at varying inspiratory pause in acute lung injury. *Clin Physiol Funct Imaging* 2007; **27**: 2-6
7. Åström E, Uttman L, Niklason L, Aboab J, Brochard L, Jonson B. Pattern of inspiratory gas delivery affects CO₂ elimination in health and after acute lung injury. *Intensive Care Med* 2008; **34**: 377-84

8. Taskar V, John J, Larsson A, Wetterberg T, Jonson B. Dynamics of carbon dioxide elimination following ventilator resetting. *Chest* 1995; **108**: 196-202

9. Sundar S, Novack V, Jervis K, et al. Influence of low tidal volume ventilation on time to extubation in cardiac surgical patients. *Anesthesiology* 2011; **114**: 1102-10