



Physics in Lund

- in time and space

Bengt Forkman & Kristina Holmin Verdozzi

Published by the Department of Physics

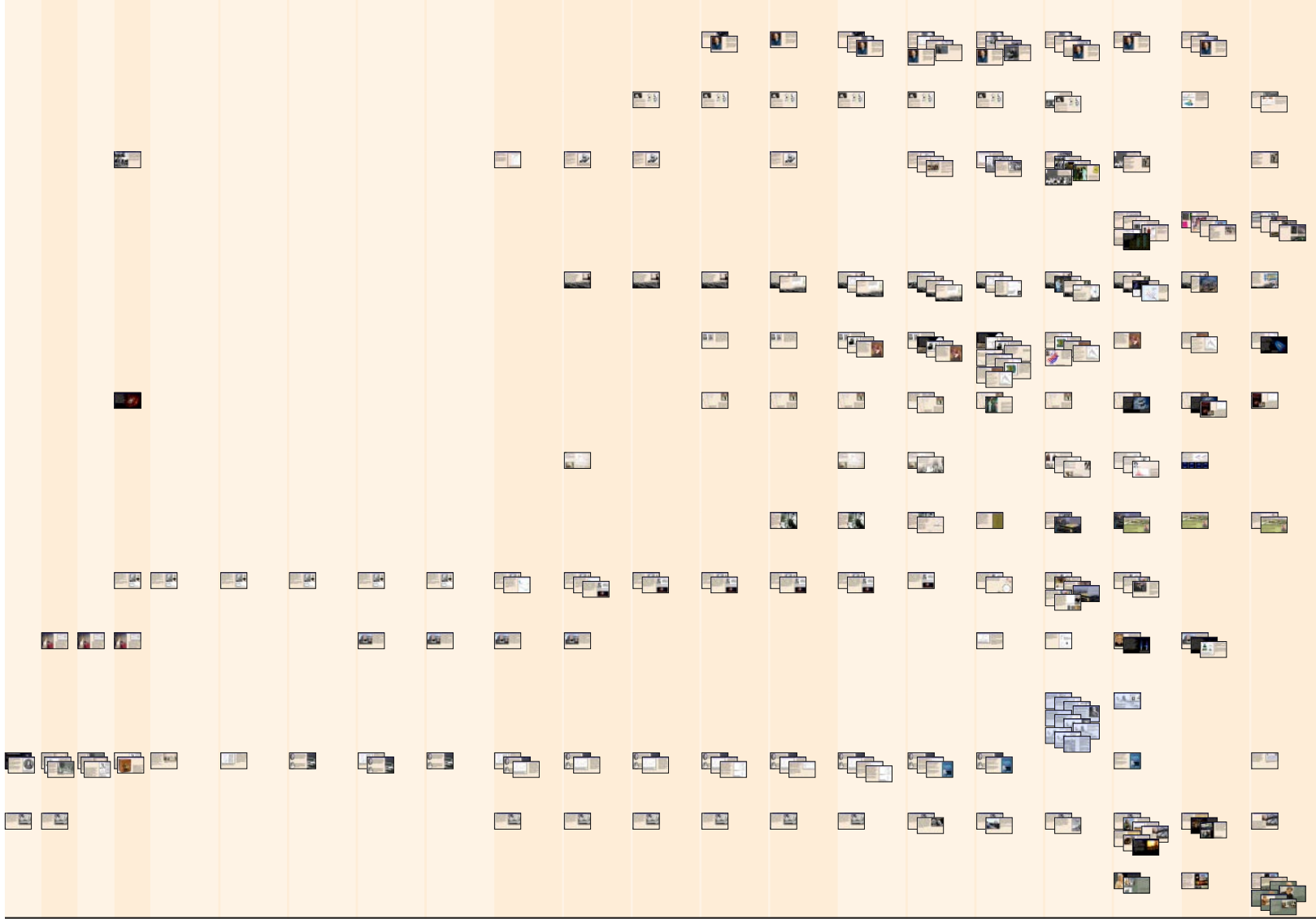

1660	1700	1750	1800	1850	1860	1870	1880	1890	1900	1910	1920	1930	1940	1950	1960	1970	1980	1990	2000	2010
------	------	------	------	------	------	------	------	------	------	------	------	------	------	------	------	------	------	------	------	------

To Barbro

*Almost sixty years ago, to the day,
I saw you for the first time
– thank you for returning my glance.*

Bengt



To Elliott Torsten Gaetano

*Thank you for sharing your history,
your future and the eternal now.*

Kristina

Physics in Lund

- in time and space

Editors:

Bengt Forkman

Kristina Holmin Verdozzi

Graphic design: Annika Nyberg

Published by the Department of Physics

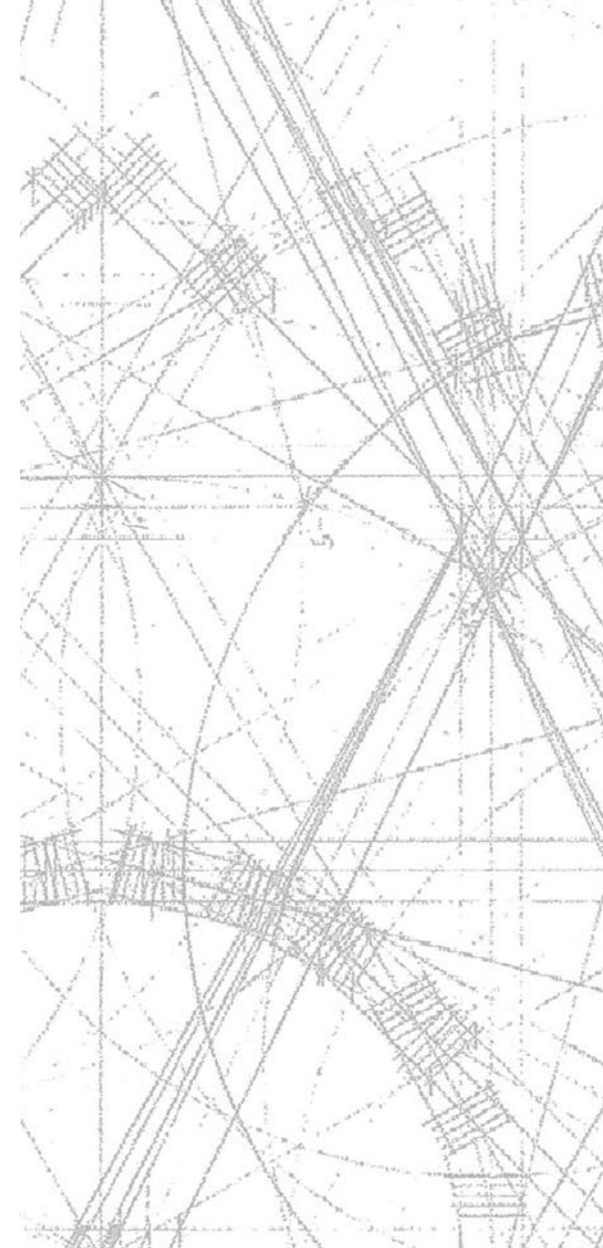

Editors: Bengt Forkman, Kristina Holmin Verdozzi
Graphic design and cover: Annika Nyberg, Motiv Reklam & Marknadsföring

Cover illustration:
Construction drawing (detail) by Britta Kleen of Lars Kleen's artwork Rope (1995).
The work is dedicated to MAX-lab. In the artwork one finds strong connections
between art and physics

English translation: Helen Sheppard

Copyright: The editors
Published by the Department of Physics
www.fysik.lu.se/english

ISBN: 978-91-7753-072-5 (pdf)

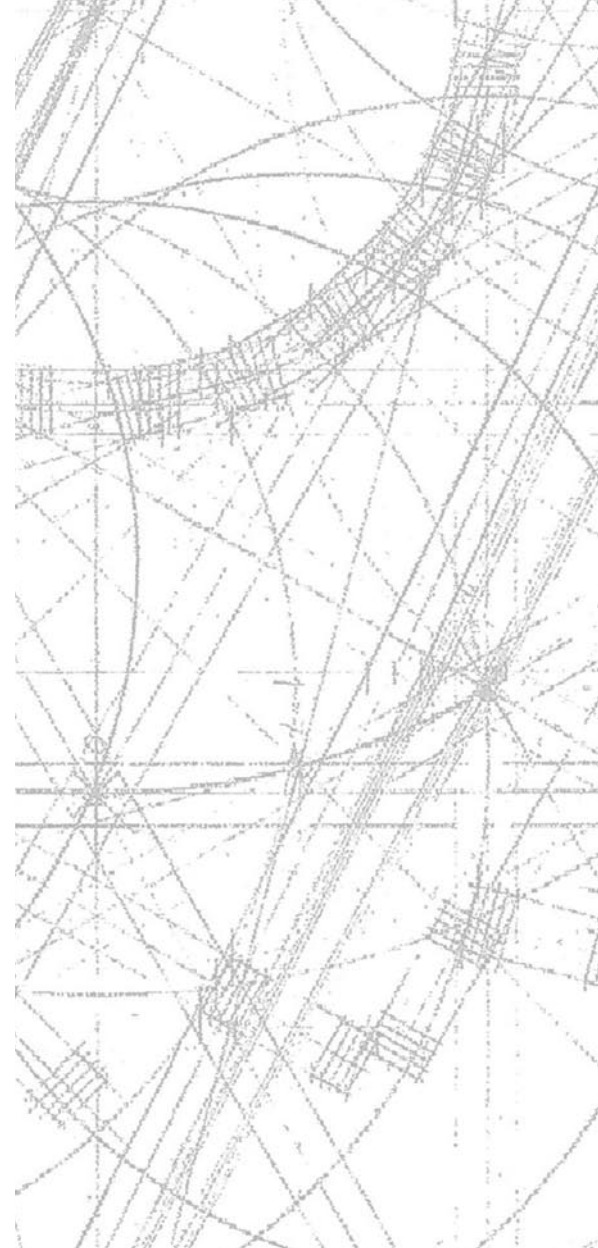

Preface

It is important to have knowledge of both the past and the present. Good ideas are always based on such knowledge, although new thoughts are also required.

Together, a professor of physics interested in history, an artistically trained librarian, and a creative designer, Annika Nyberg, have tried to describe Physics in Lund and its 350-year history.

This has been made possible by the work of the Historical Group at the Department of Physics, which was founded in 2011, and consists of the undersigned together with Ulf Litzén (Professor in Physics) and Carl-Erik Magnusson (University Lecturer). This book is based on a large screen presentation which has been on display in the main entrance of the Department since 2012.

This portrayal is intended for the broader public, politicians, funding bodies and other decision-makers, as well as students and others with an interest in physics.

The past 50 years have seen exceptional successes at the Department due to world-class research. Furthermore, the national facility, MAX IV, has its roots in the Department, and has helped in bringing the European Spallation Source (ESS) to Lund.

Where does this driving force come from?

There are several reasons for the success of the Department. One is undoubtedly the fact that the Faculty of Engineering, LTH, which was established at the beginning of the 1960s, was not made an independent institute, but was integrated into Lund University. Another is that the Department of Physics is a large, joint department including both the Science Faculty and the Engineering Faculty, in equal measure.

Each chapter of this book has its main authors, and is designed as an interaction between image and text. Each of the authors has had the help of others in both writing and choosing the illustrations. In a presentation such as this it is always necessary to make a choice regarding which material should be included. Some areas of research could have been described in more detail, and many other people should have been mentioned. However, it is important to point out that all the former and present employees of the Department have helped form its history.

We are convinced that we can all become better and wiser researchers, lecturers and administrators if we know the history behind our place of work. Such knowledge provides a firm foundation on which to work, and creates greater respect for the way in which knowledge is gained.

Bengt Forkman
Professor of Physics

Kristina Holmin Verdozzi
Faculty Librarian

















Acknowledgements

This book was made possible by the contributions of many people, not only the main authors, but also those who helped them. We would like to express our special thanks to professors Gösta Gustafson, Ulf Litzén och Hans Ryde, whose broad knowledge has enriched this book. We are also grateful to the reference group that helped us find the right tone for this presentation.

This project was realized thanks to generous financial contributions from *Akademiska Hus*, Birgit & Håkan Ohlsson's Foundation, The Crafoord Foundation, The Royal Physiographic Society of Lund, The Krapperup Estate, The Faculty of Science at Lund University, *Sparbanken Öresund*, Sten K Johnson's Foundation, The Längman Culture Foundation and Thora Ohlsson's Foundation. We are also grateful for the cooperation of the management of the Department. In this context, we would also like to thank professors Mats Benner and Thomas Kaiserfeld for their letters of recommendation.

We would also like to thank Kristina Danielsson, for her excellent proof-reading, Helen Sheppard, for her insightful translations, which enriched the Swedish texts, and Henrik Ruuth and Ylva Forkman for their valuable help in the indexes of people and images.

Table of content

	From fencing hall to nano church 1 How the Department of Physics grew from one room in Kungshuset to today's large department. <i>Bengt Forkman</i>		Sven Johansson and environmental physics 133 The chemical engineer who became a nuclear physicist, environmental physicist and Vice-chancellor of Lund University. <i>Bengt Forkman, Roland Axelsson, Eva-Martha Johansson</i>
	Janne Rydberg and his formula 18 On how a numerical genius from Halmstad became world famous. <i>Bengt Forkman, Ulf Litzén</i>		Atmospheric aerosols 150 Particles and gases in the atmosphere form aerosols that can affect the climate and our health. <i>Birgitta Svenningsson, Erik Swietlicki and Bengt Martinsson</i>
	The Nobel Prize Laureate who disappeared 33 How a man from Örebro was awarded the Nobel Prize thanks to a lucky eye for design and great attention to detail. <i>Bengt Forkman, Ulf Litzén</i>		Ein Hertz für das Herz 165 How one family of physicists repeatedly makes epoch-making discoveries through the generations. <i>Lennart Gråhm</i>
	Successful students 49 Licentiates, doctoral students, and one lecturer, 1900 - 1930. <i>Bengt Forkman, Ulf Litzén</i>		Ekman and Källén 181 Two world famous theoreticians from Lund. <i>Bengt Forkman, Cecilia Jarlskog, Ulf Litzén</i>
	Two friends 66 Two physics students – and how their lifelong friendship enriched both politics and physics. <i>Sverker Oredsson</i>		Sven Gösta Nilsson and his Model 197 One of the most successful theoretical models of the atom ever developed, and the man responsible. <i>Ingemar Ragnarsson, Hans Ryde</i>
	The corona mystery 83 About the man who solved the corona mystery and at the same time proved that the temperature, just above the surface of the sun, is 2 million degrees instead of 6000 that had previously been assumed. <i>Ulf Litzén</i>		Symmetry in the world of atomic nuclei 214 The properties of atomic nuclei and the existence of superheavy nuclei. <i>Ingemar Ragnarsson, Sven Åberg</i>
	Cosmic radiation and heavy-ion physics 100 How scientists in Lund determined the properties of the strange K mesons, and then recreated the physical processes taking place a few millionths of a second after the Big Bang. <i>Bo Jakobsson, Ingvar Otterlund, Evert Stenlund</i>		Physics in Lund gets a boost, or two! 231 How a Vice-chancellor charms Malmö politicians and secures an institute of technology in Lund, and how a new type of spectroscopy is introduced. <i>Håkan Westling</i>
	The nucleus in the spotlight 116 The development of nuclear physics in Lund – electrostatic accelerators, electron accelerators, Ur-MAX, LUSY, MAX-lab and some aspects of applied nuclear physics. <i>Claes Fablander, Bengt Forkman, Ragnar Hellborg</i>		Lars Hedin and the theory of solid state physics 246 How Lars Hedin's own work and the theoretical research in solid state physics began and developed in Lund under his leadership. <i>Carl-Olof Almladh, Ulf von Barth</i>

	Theoretical condensed matter physics 262 Theoreticians at the Division of Mathematical Physics are working to understand and predict the quantum mechanical properties of matter on the subatomic, atomic, and nanometre scales. <i>Ulf von Barth, Claudio Verdozzi, Peter Samuelsson</i>		Combustion physics 409 How a Master's project in combustion diagnostics led to a new division at the Department of Physics and together with other divisions at LTH formed the Thulin Laboratory. <i>Marcus Aldén, Per-Erik Bengtsson, Johan Zetterberg</i>
	Semiconductor physics 279 How solid state physics came to Lund. <i>David Lindgren</i>		Foreign submarine 426 A serious political conflict between Sweden and the Soviet Union, in which a Lund physicist played an active role. <i>Ragnar Hellborg</i>
	Nanotechnology 292 The growth of the nano concept in Lund. <i>David Lindgren</i>		The development of teaching 439 When were students first taught experimental techniques in the lab? When was it decided that a doctoral thesis had to be written independently by the student? When did a woman get a PhD in Physics in Lund for the first time? <i>Rune Kullberg, Per Olof Zetterberg, Bengt Forkman</i>
	Exploring the microcosmos 309 How physicists in Lund measured a new scattering effect, helped determine the number of families of leptons and quarks, and took part in the hunt for the Higgs particle. <i>Göran Jarlskog, Leif Jönsson, Gösta Gustafson</i>		External activities 456 How physicists from Lund made science understandable for everyone. <i>Bengt Forkman, Per Olof Zetterberg</i>
	The Lund model for high energy collisions 326 The famous Lund model – theoretical ideas meet experimental reality. <i>Gösta Gustafson, Carsten Petersson</i>	Past – present – future 473 <i>Kristina Holmin Verdozzi</i>	Discussions on the growth of physics in Lund 475 A discussion on the expansion of the Department of Physics and the secrets behind its success. <i>Lena Björk Blixt</i>
	Fast atoms and shining stars 343 How spectral lines tell us the lifetimes of excited atoms and the chemical composition of stars. <i>Ulf Litzén</i>		The future of the Physics Department 488 <i>Knut Deppert</i>
	When the laser came to Lund 358 On how it happened and how it eventually led to a world record. <i>Sven-Göran Petersson</i>	Topics from modern physics 498 <i>Anne L'Huillier</i>	List of photos, images and illustrations 507
	Lord of the Rings 375 The story of baby MAX – how he learned to walk and grew up to be big and strong. <i>Bengt Forkman, Per-Åke Hultberg</i>	List of persons 511	
	The synchrotron light from Lund 392 The story of how physicists in Lund learned to use synchrotron light. <i>Ingolf Lindau, Stacey Ristinmaa Sörensen</i>		



From fencing hall to nano church

How the Department of Physics grew from one room in Kungshuset to today's large department.

Physics in the Cathedral

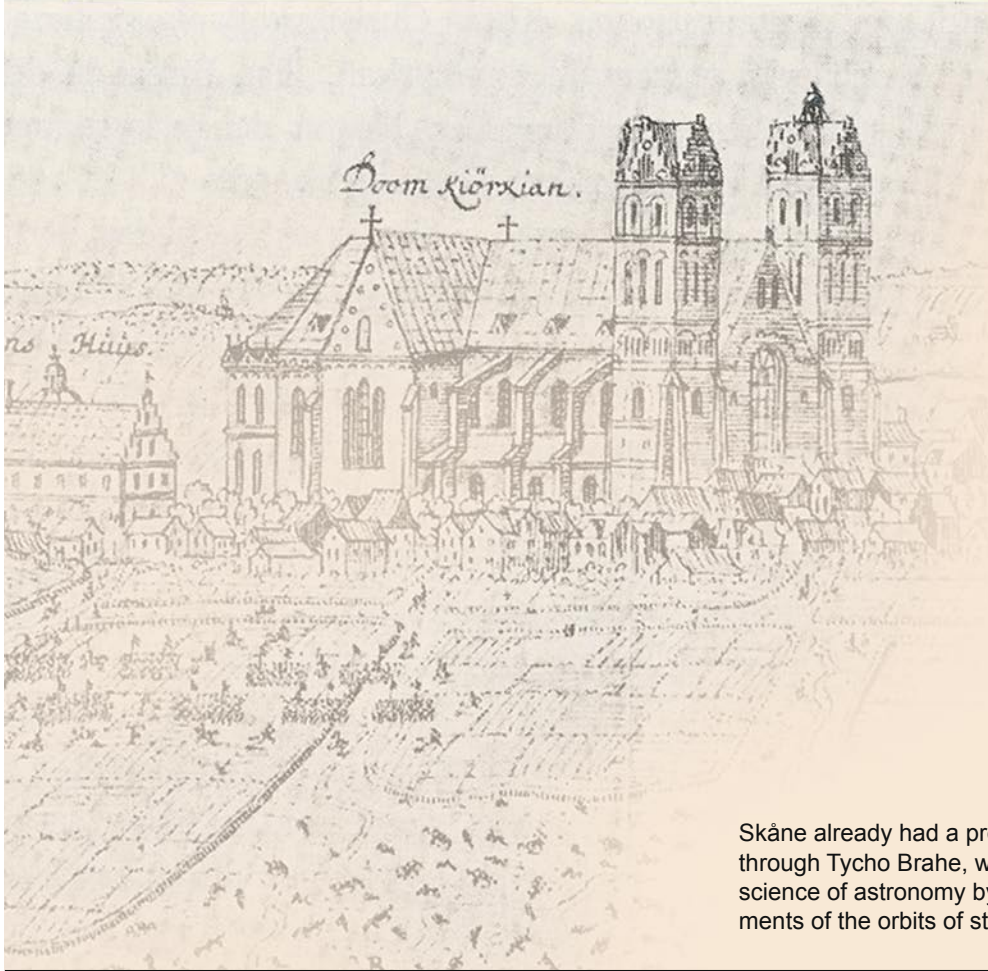

When Lund University was founded in 1666, there was no specific chair in physics as we understand it today. It was first and foremost the two professors of mathematics who taught physics.

The University's teaching took place in three places: in the choir of the cathedral, in Peter Lykke's chapel in the south-western part of the Cathedral and in the fencing hall in the medieval Liberiet.



Tycho Brahe 1546 - 1601

Skåne already had a proud tradition of astronomy through Tycho Brahe, who had revolutionised the science of astronomy by making careful measurements of the orbits of stars, planets and comets.

Triewald's instrument collection

Lund's first chair in experimental physics was established in 1728 and was held by Kilian Stobæus. However, Daniel Menlös was to have a greater impact on the physics in Lund.

In the years 1728–1729, the Swedish merchant, engineer and amateur physicist Mårten Triewald held lectures at the Swedish House of Nobility in Stockholm on *the new natural science*.

At the lectures he demonstrated an advanced collection of physics instruments that he had purchased in England, assisted by Daniel Menlös.

Large parts of Triewald's collection are now stored at the Science and Maritime House in Malmö.

The instrument collection illustrated by Niclas Schenmark, a pupil of Professor Menlös.

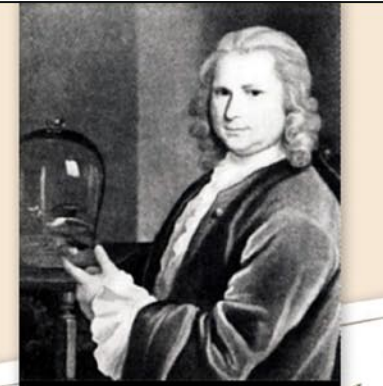

Mårten Triewald 1691 - 1747

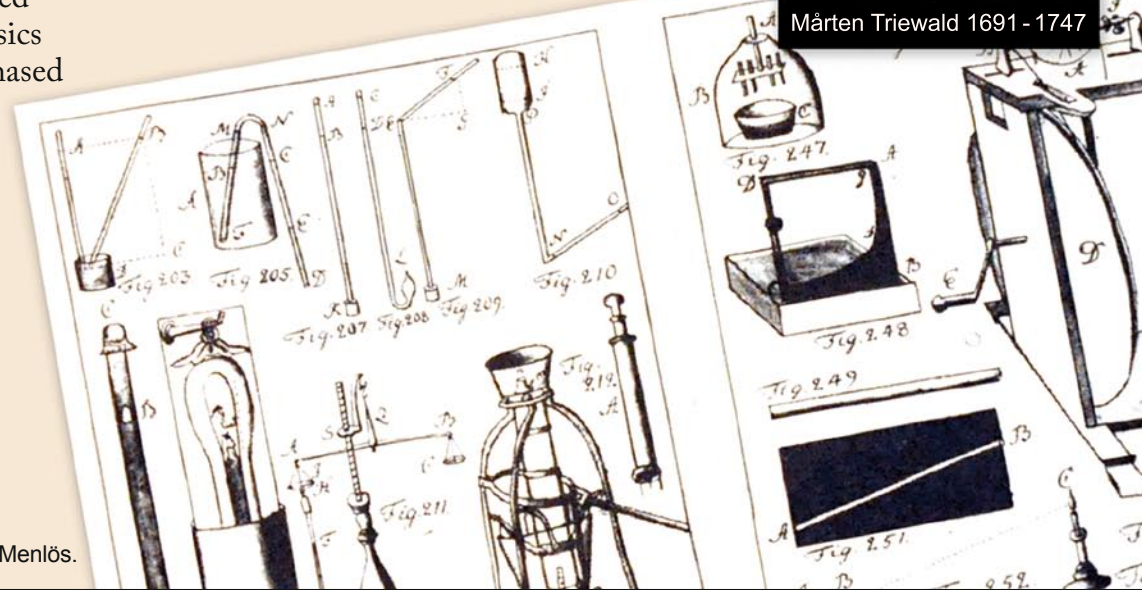

Menlös becomes professor in Lund

Through an agreement with Triewald, Menlös used the instrument collection as a lure when he applied for the chair in mathematics in Lund, promising to donate the collection to the University if he was given the chair.

Menlös was not highly qualified for the post, but thanks to the promise of the instrument collection, he was appointed professor in 1732.

He became the first to introduce Newtonian physics to Lund University.

Otto von Guericke's air pump, which belongs to the Department of Physics, was used in the famous experiment with the Magdenburg hemispheres in 1650.



Daniel Menlös 1699 - 1743



First department premises 1735

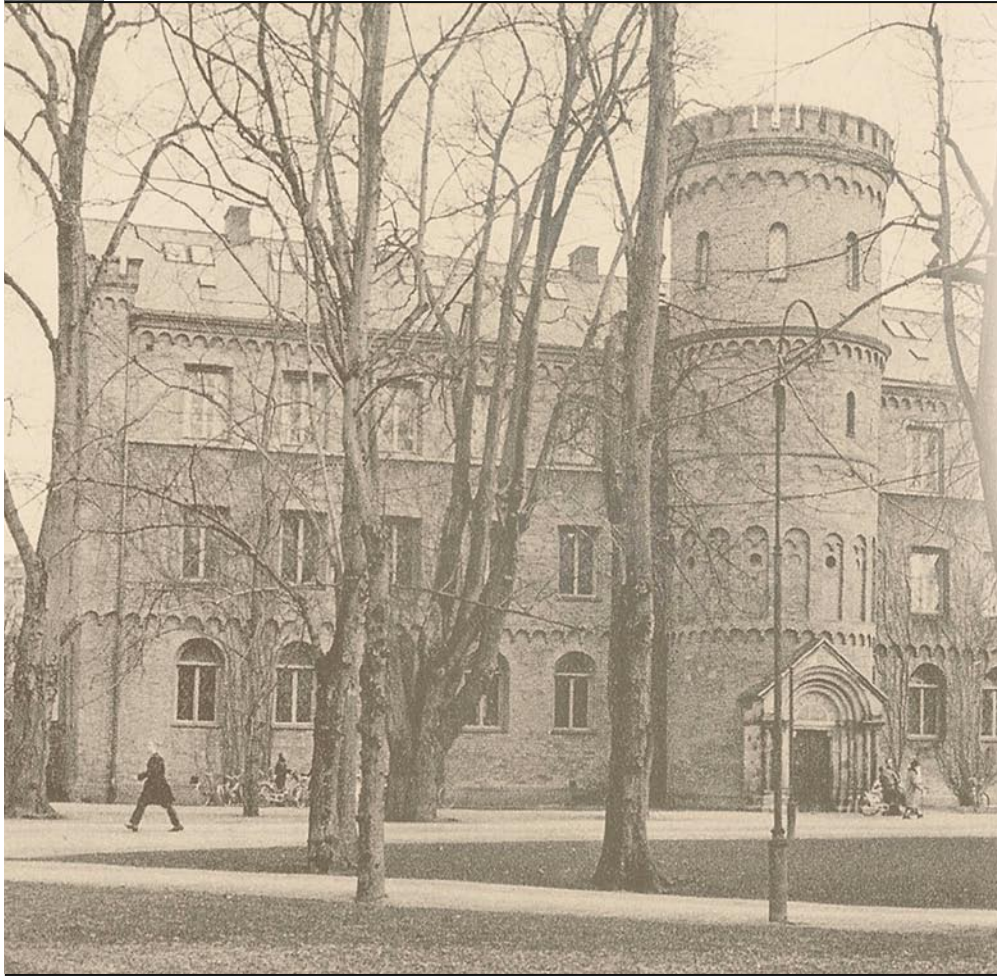

A monetary gift of 6 000 daler from Queen Ulrika Eleonora was used to rebuild Kungshuset. On the first floor, a lecture theatre was furnished as an amphitheatre (*auditorium anatomicum-physicum*) and a room was prepared for the Triewald collection. In 1735, the alterations were complete and the collection could be installed.

It is correct to say that the Department of Physics now had its own premises, even if it was only one room.

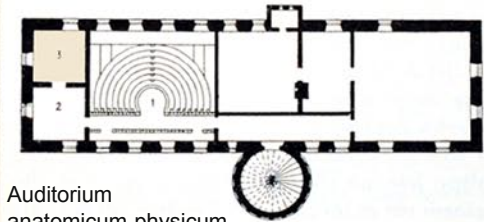

Auditorium
anatomicum-physicum

Four years on Helgonabacken

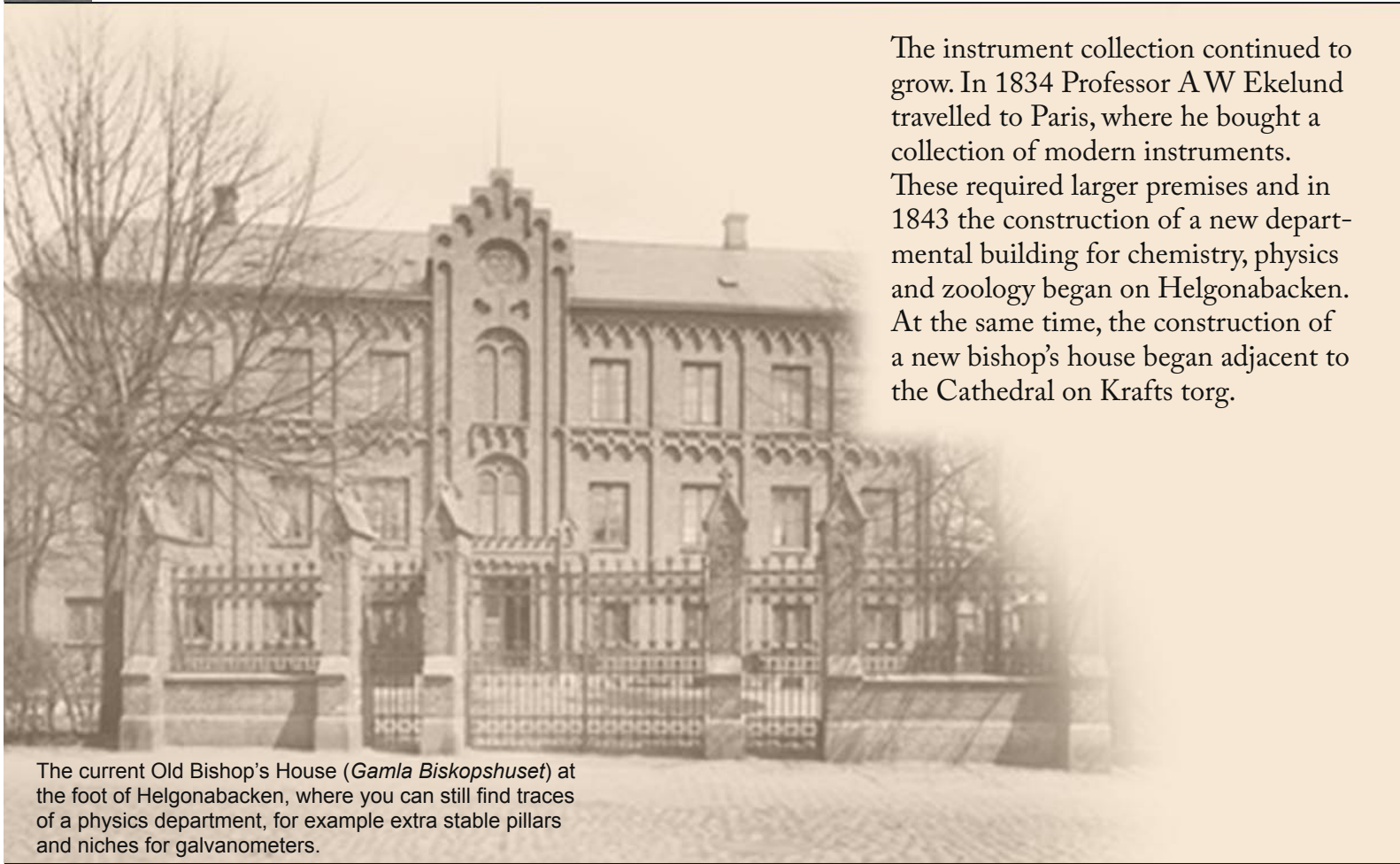

The instrument collection continued to grow. In 1834 Professor A W Ekelund travelled to Paris, where he bought a collection of modern instruments. These required larger premises and in 1843 the construction of a new departmental building for chemistry, physics and zoology began on Helgonabacken. At the same time, the construction of a new bishop's house began adjacent to the Cathedral on Krafts torg.

The current Old Bishop's House (*Gamla Biskopshuset*) at the foot of Helgonabacken, where you can still find traces of a physics department, for example extra stable pillars and niches for galvanometers.

Krafts torg 1850–1886

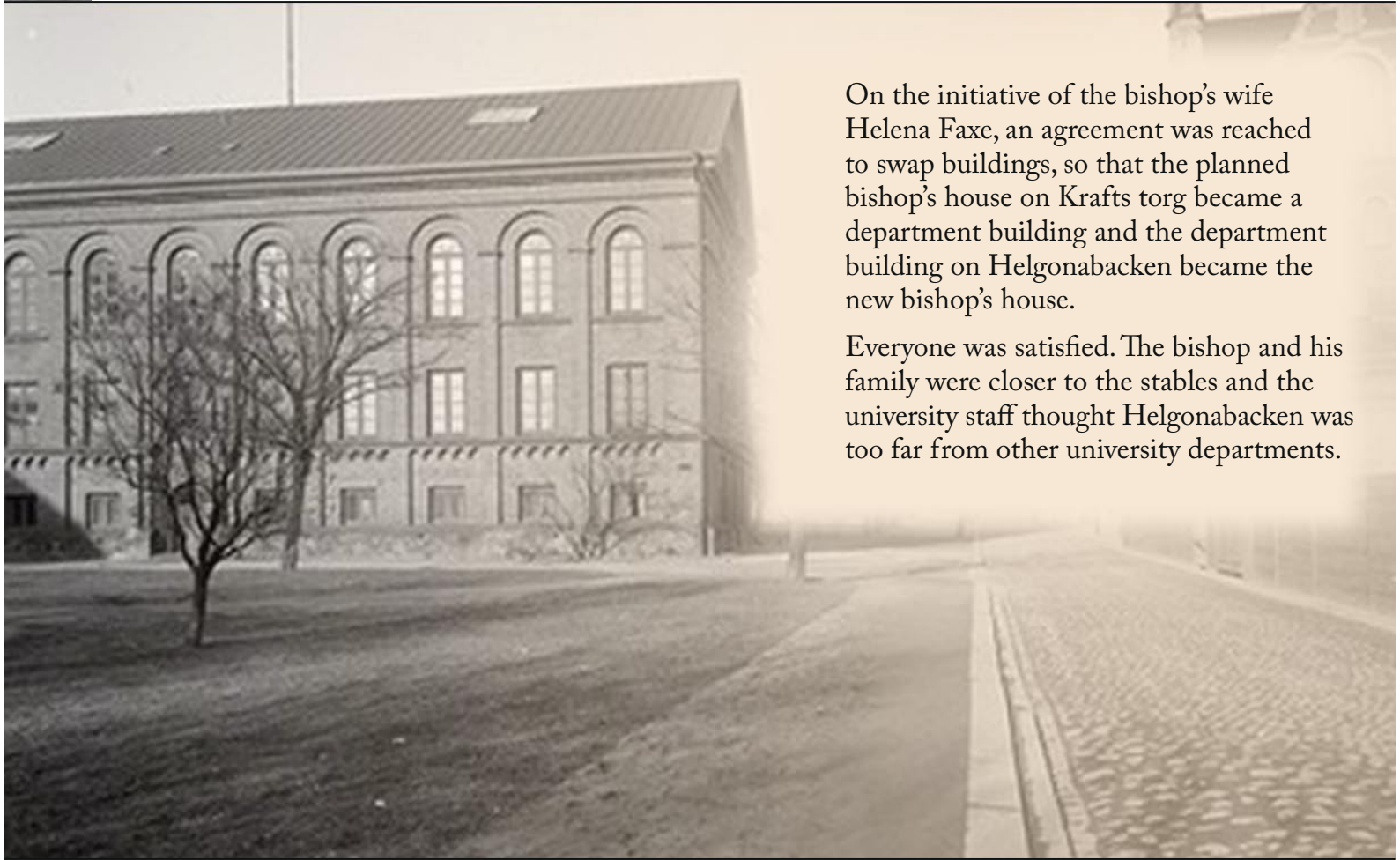

On the initiative of the bishop's wife Helena Faxe, an agreement was reached to swap buildings, so that the planned bishop's house on Krafts torg became a department building and the department building on Helgonabacken became the new bishop's house.

Everyone was satisfied. The bishop and his family were closer to the stables and the university staff thought Helgonabacken was too far from other university departments.



Own building 1885

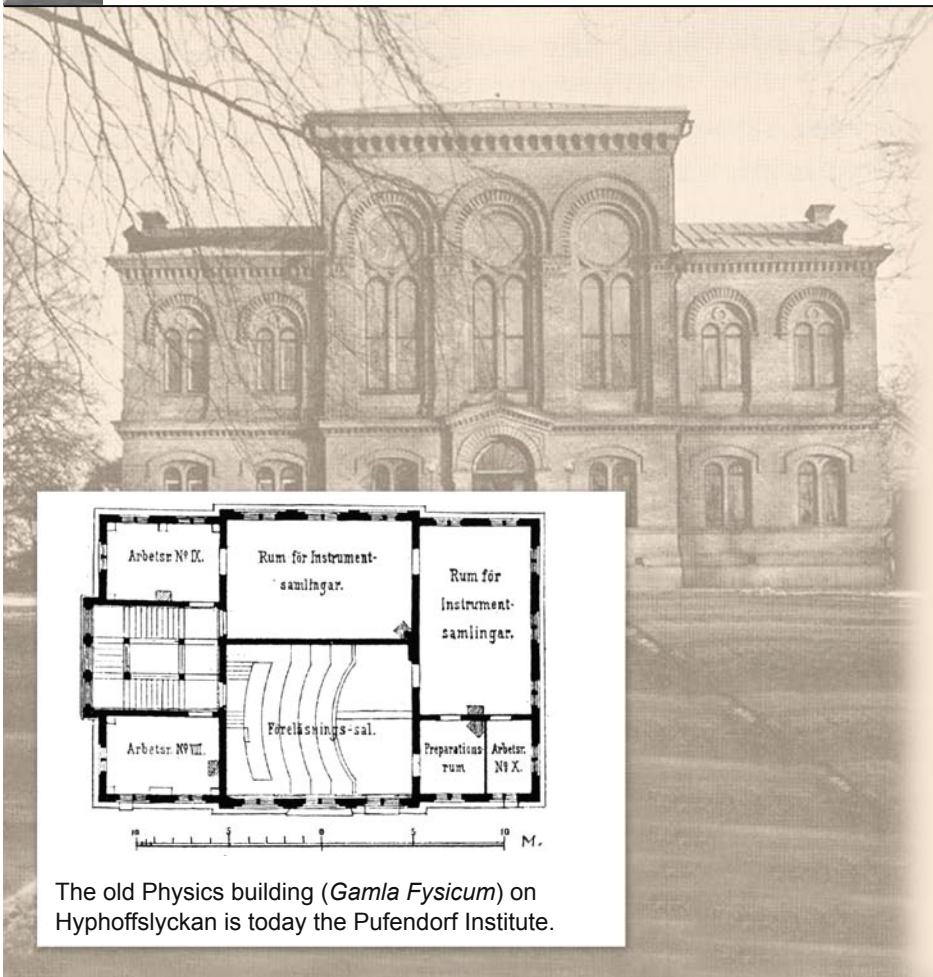

During the latter part of the 19th century, it became overcrowded once again. In order to manage the situation, Professor Holmgren rented a two-bedroom flat in the city and arranged for it to be furnished as a makeshift laboratory for research students' use.

In 1882 the Swedish Parliament awarded a grant of SEK 105 000 for a new Physics Department in Lund. The building was completed in autumn 1885 and housed two instrument rooms, an auditorium, 11–12 offices, a library, an assistants' room, a workshop, and a storeroom. There was still no designated area for laboratory exercises for undergraduate students.

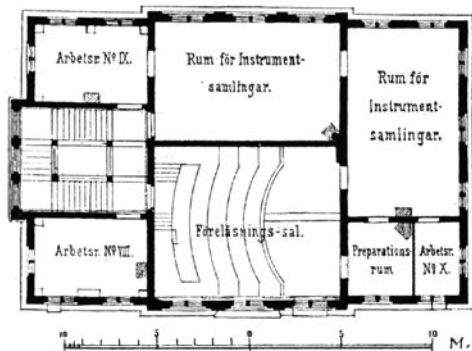

The old Physics building (*Gamla Fysicum*) on Hyphoffslyckan is today the Pufendorf Institute.



Karl Albert Victor Holmgren
1824 - 1905

19th century MAX-lab

In the park surrounding the old Physics building is a curious little building built specially to house a telescope and star spectroscope.

The instrument could be used to measure star spectra and had been donated to the department by a former student, senior lecturer A E Andersson. The building is still called Donavit after an inscription on the wall that is no longer visible: *AEA donavit* (*donavit* = Latin for *has given*).

Donavit can be considered the predecessor to MAX IV Laboratory, the national synchrotron radiation laboratory, because it was the first building erected in Lund solely for spectroscopic measurements.

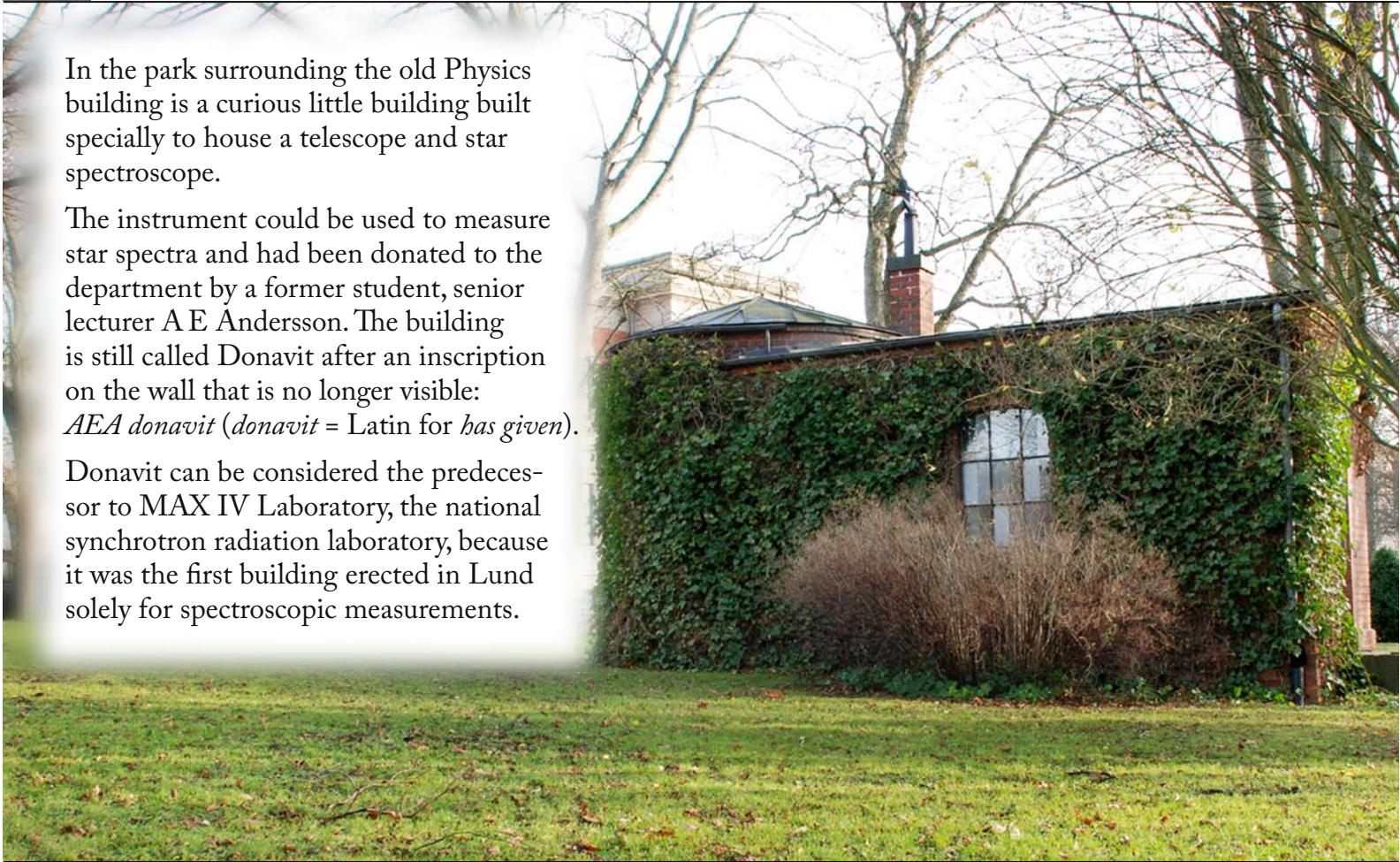

Sölvegatan 1950–

John Koch, who succeeded Manne Siegbahn as professor in 1924, worked tirelessly to acquire further premises. However, the Second World War supervened. It was therefore Koch's successor, Bengt Edlén, who took over the responsibility for finding a solution when he was appointed to the chair in 1943.

The new building on Sölvegatan was taken into service in 1950 and officially opened in 1951 by King Gustaf VI Adolf.



Pride and community

Everyone thought the new building, Fysicum, was magnificent and were proud to work there. This also created a strong sense of community.

Every afternoon at 15:00 staff drank coffee together and a seminar was held every Friday evening, at which different aspects of the rapid developments within physics were illuminated.



Continued expansion

The need for space for research and teaching continued to increase, however, and in addition to the original buildings (marked in red) the department grew as follows until 1965.

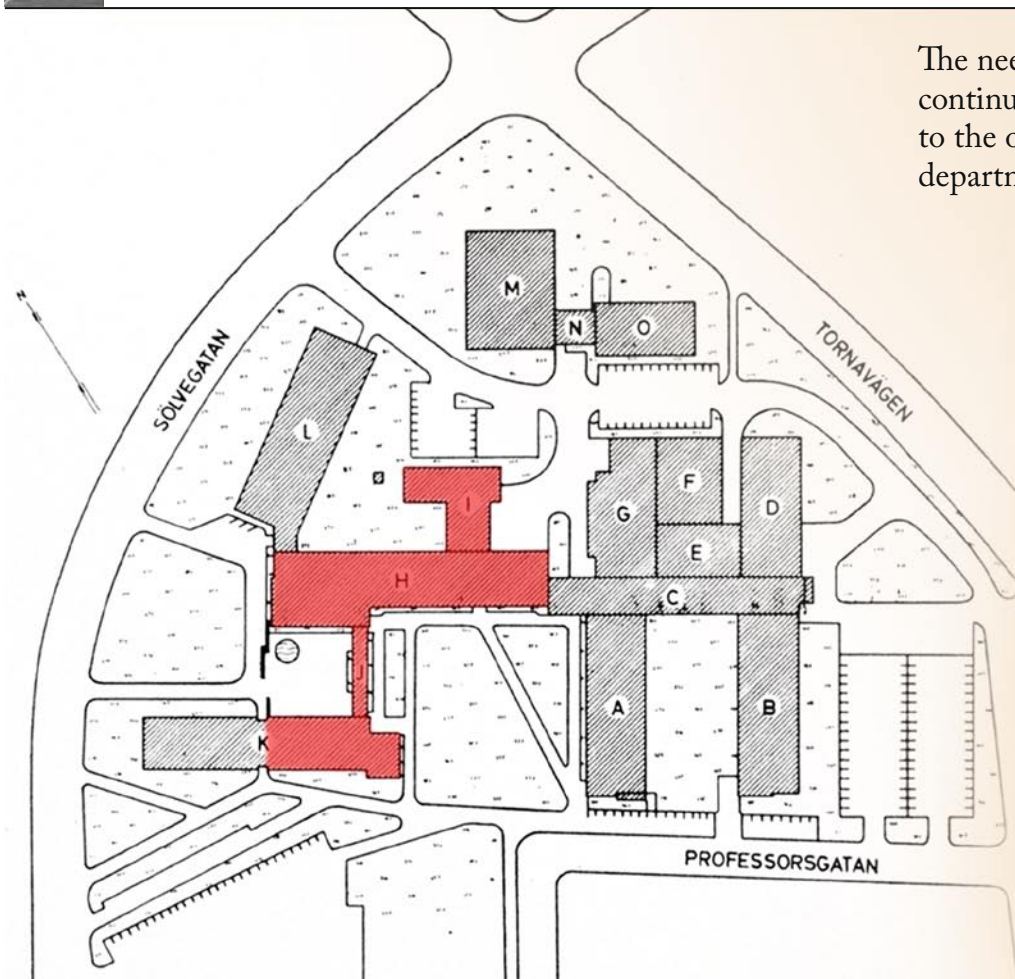

- 1957 Synchrotron hall (G)
- 1961 Course laboratory (L)
- 1962 Extension for Theoretical Physics (K)
- 1964 Course laboratories for LTH (M, N, O)
- 1962–1965 New buildings with the establishment of LTH (A, B, C, D, E, F)

Academic workshop

The department on Sölvegatan could pride itself on a well-equipped workshop where a number of skilled instrument makers manufactured the majority of the experiment equipment for the research divisions.

When LTH was established, demand increased and a second mechanical workshop was added.

In 1994, the mechanical workshops were merged in a new workshop wing with modern equipment. In 2011, five people served the entire university and Ideon Science Park. In December 2012 the workshop was closed down.



The Academic workshop, 2011.

The workshop at the Department of Physics, 1951.

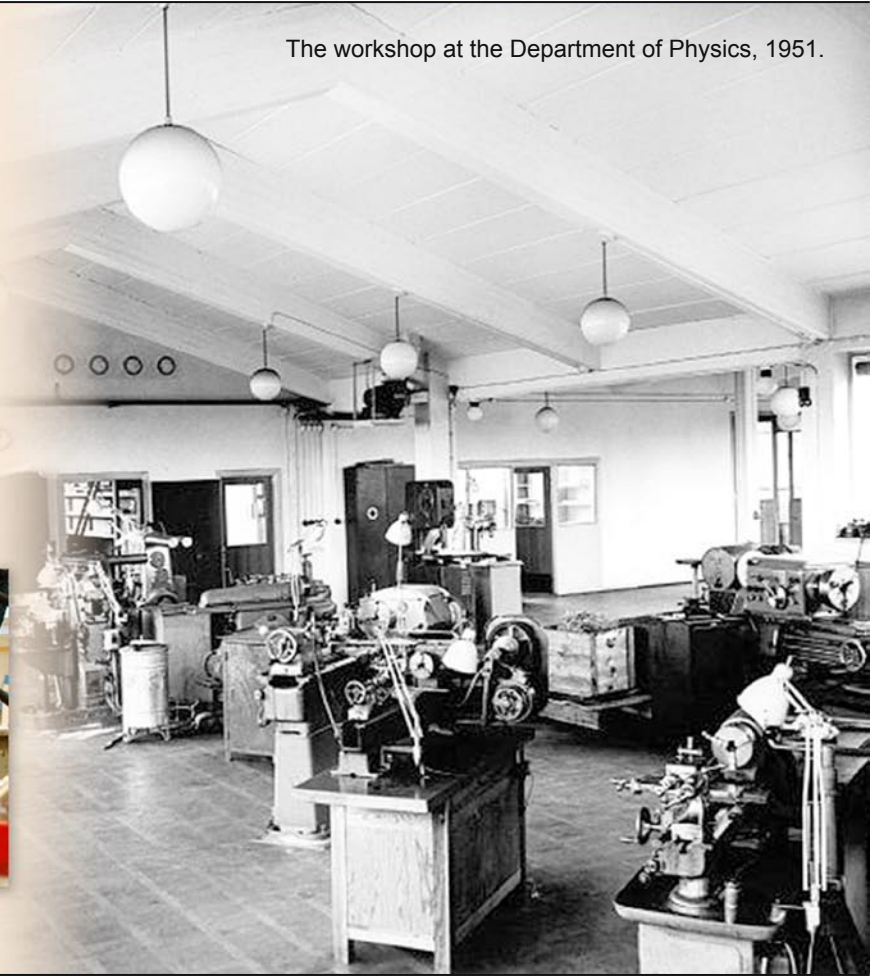

Main library

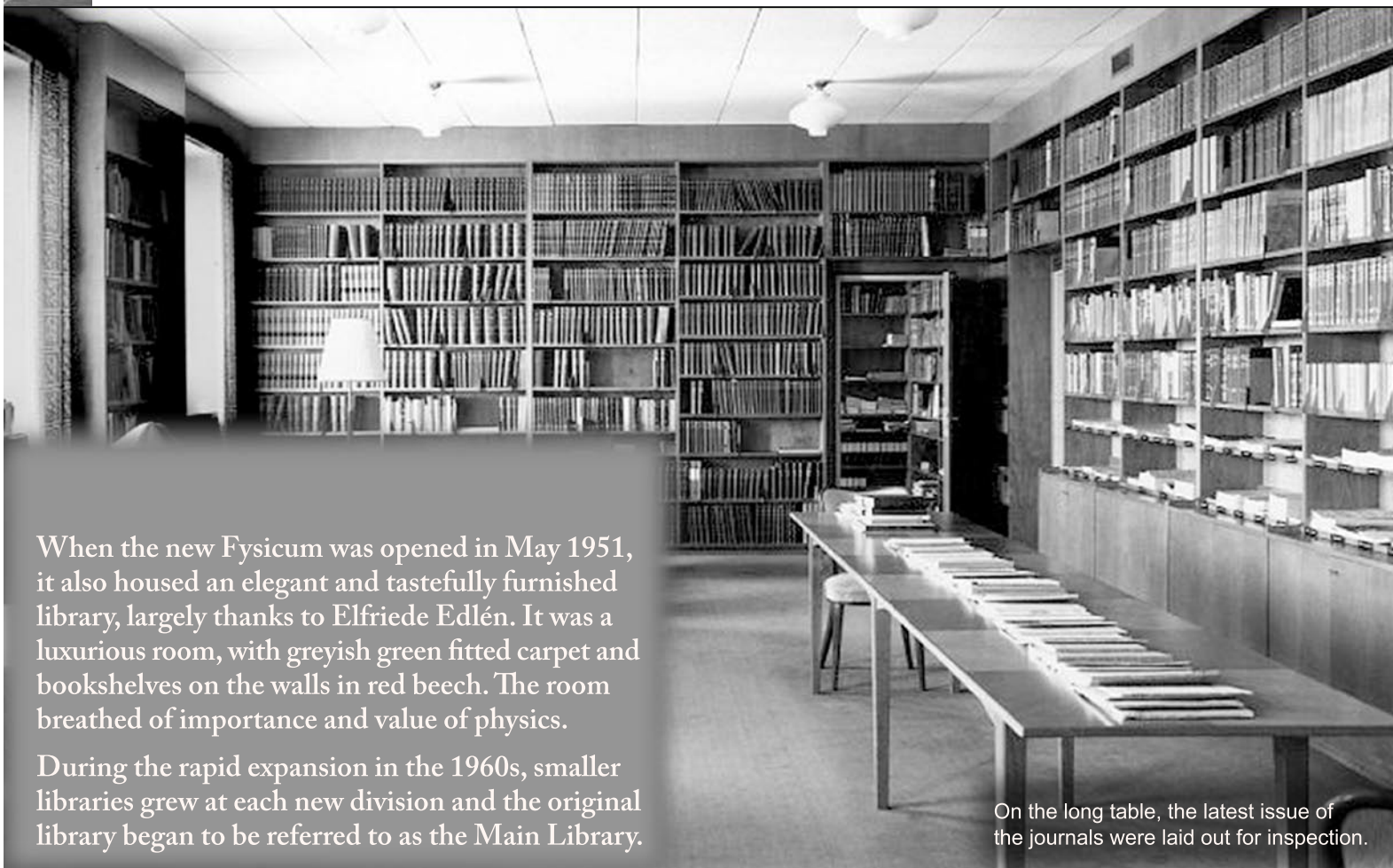

When the new Fysicum was opened in May 1951, it also housed an elegant and tastefully furnished library, largely thanks to Elfriede Edlén. It was a luxurious room, with greyish green fitted carpet and bookshelves on the walls in red beech. The room breathed of importance and value of physics.

During the rapid expansion in the 1960s, smaller libraries grew at each new division and the original library began to be referred to as the Main Library.

On the long table, the latest issue of the journals were laid out for inspection.

Shared library 2006

Unmanned collections spread out across the department eventually made finding items difficult. When Kristina Holmin Verdozzi took up the new post of librarian in 2001, planning began in earnest for a new, shared library. The problem was finding suitable premises.

When the decision was taken to close down the Pelletron accelerator, the large machinery hall stood empty and after extensive renovation and alteration it was able to house the shared library.

The new library, 2006.



Combustion physics

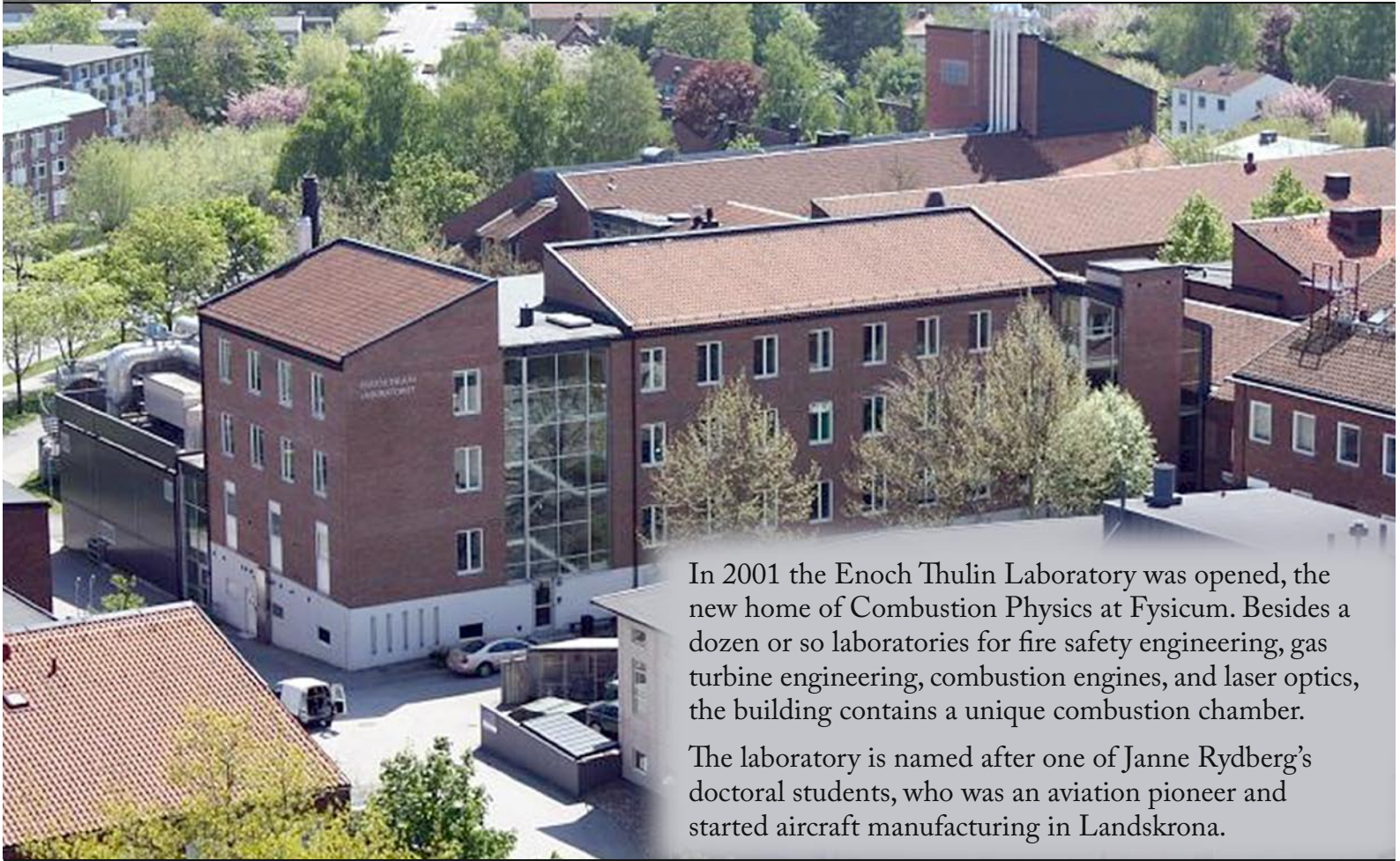

In 2001 the Enoch Thulin Laboratory was opened, the new home of Combustion Physics at Fysicum. Besides a dozen or so laboratories for fire safety engineering, gas turbine engineering, combustion engines, and laser optics, the building contains a unique combustion chamber.

The laboratory is named after one of Janne Rydberg's doctoral students, who was an aviation pioneer and started aircraft manufacturing in Landskrona.



The nano church



The first sod is turned for the Berzelius Laboratory, with the Professors Hermann Grimmeiss, Bengt Edlén, and Nils Stjernquist.

After twenty years in cramped premises in building A at Fysicum, in 1984 it became possible for Hermann Grimmeiss, Professor of solid state physics, to move into a newly built wing of Fysicum which was named the Berzelius Laboratory (building Q).

In 2007 the wing was extended and specially equipped for the new activities in nanophysics and *the nano church* became a new feature of Fysicum.



Janne Rydberg and his formula

On how a numerical genius from
Halmstad became world famous.

The man behind the formula



Johannes Robert Rydberg, better known as Janne Rydberg, was born in Halmstad in 1854. At the age of 19 he moved to Lund and began studying mathematics at Lund University.



The periodic table

Gruppe I. R ⁰	Gruppe II. R ⁰	Gruppe III. R ⁰	Gruppe IV. R ⁰	Gruppe V. R ⁰	Gruppe VI. R ⁰	Gruppe VII. R ⁰	Gruppe VIII. R ⁰
1 H=1							
2 Li=7	Be=9,4	B=11	C=12	N=14	O=16	F=19	
3 Na=23	Mg=24	Al=27,3	Si=28	P=31	S=32	Cl=35,5	
4 K=39	Ca=40	—=44	Ti=48	V=51	Cr=52	Mn=55	Fe=56, Co=59, Ni=59, Cu=63.
5 (Ca=63)	Zn=65	—=69	—=72	As=75	Se=78	Br=80	
6 Rb=85	Sr=87	?Yt=88	Zr=90	Nb=94	Mo=96	—=100	Ru=104, Rh=104, Pd=106, Ag=108.
7 (Ag=108)	Cd=112	In=113	Sn=118	Sb=122	Te=125	J=127	
8 Ca=133	Ba=137	?Di=138	?Ce=140	—	—	—	—
9 (—)	—	—	—	—	—	—	—
10 —	—	?Er=178	?La=180	Ta=182	W=184	—	Os=195, Ir=197, Pt=198, Au=199.
11 (Au=199)	Hg=200	Tl=204	Pb=207	Bi=208	—	—	—
12 —	—	—	Th=231	—	U=240	—	—



Dimitri Ivanovich Mendeleev 1834 - 1907

During his first years as a student, Rydberg developed a strong interest in the periodic table of the elements, which had been published in the 1860s by Russian Professor of Physics Dimitri Ivanovich Mendeleev.

In the table, all the known elements, 63 in total, were arranged in increasing order of atomic weight, and elements with similar chemical properties were placed below one another. Gaps in the table showed that not all the elements had yet been discovered.

Why is the table periodic?

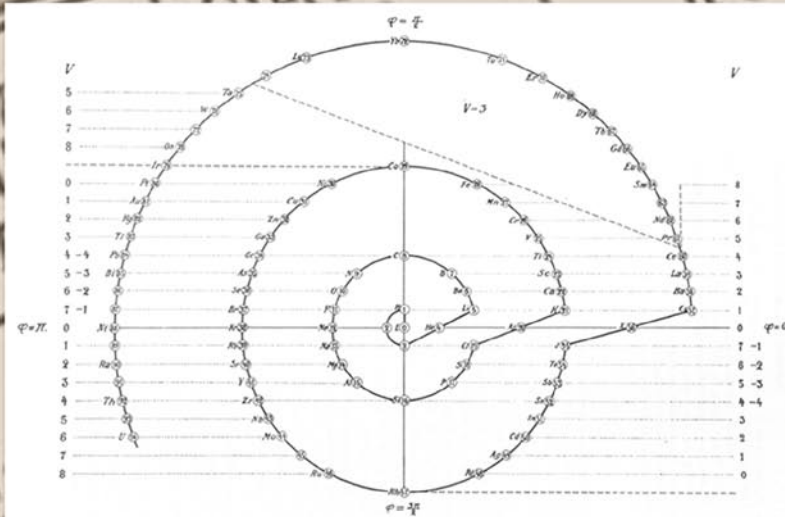

In one of his attempts to find a mathematical explanation, Rydberg placed the elements in a spiral.

Rydberg's interest in mathematics and numbers meant that he wanted to find a mathematical explanation of the periodic variation in the properties of the elements.

He suspected that there was a connection with another of the unsolved mysteries of physics, the spectral lines of the elements. Unexplained regularities had also been observed there.

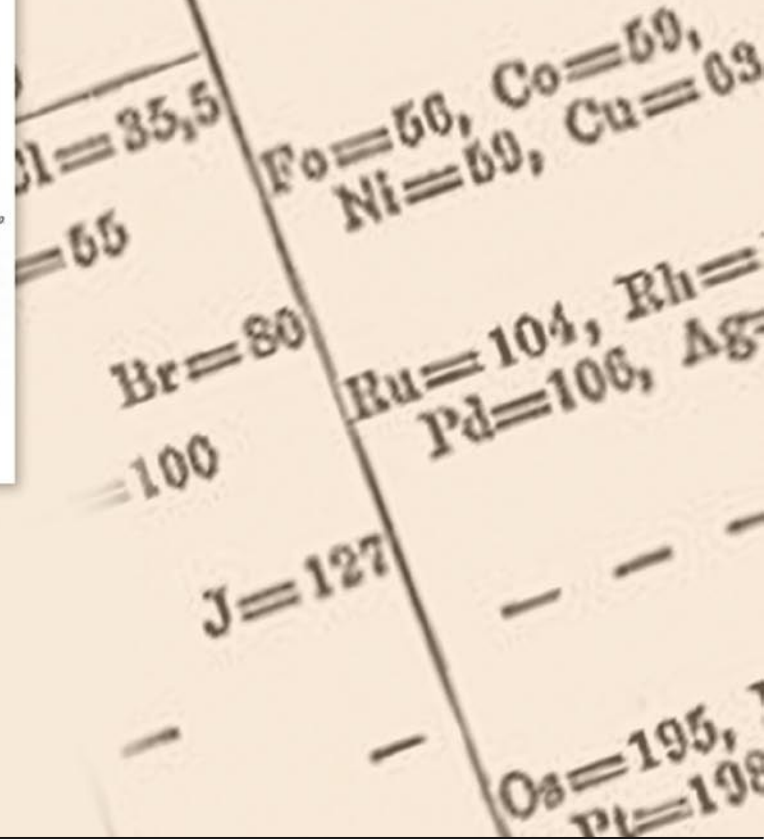

Spectral lines

In the 1660s, Newton showed that the colours seen when sunlight passes through a prism are found in the sunlight itself – they do not come about in the glass.

Around the year 1800, Thomas Young showed that light behaves like a wave motion. He was able to measure the wavelength of different colours.



In 1814, Fraunhofer studied sunlight. He placed a narrow slit in front of the prism and used a telescope to study the light through the slit. He saw narrow dark lines in the continuous spectrum.

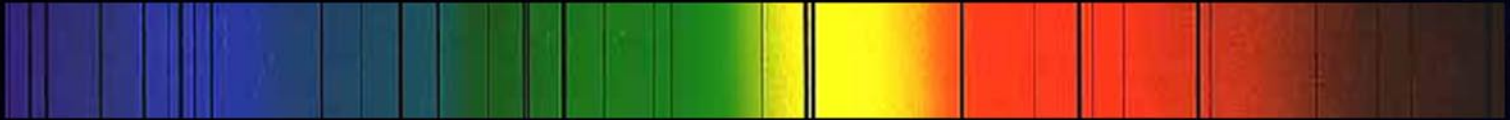

When he instead placed a gas flame in front of the slit, he saw narrow bright lines, some of them in the same places as the dark lines in the solar spectrum.

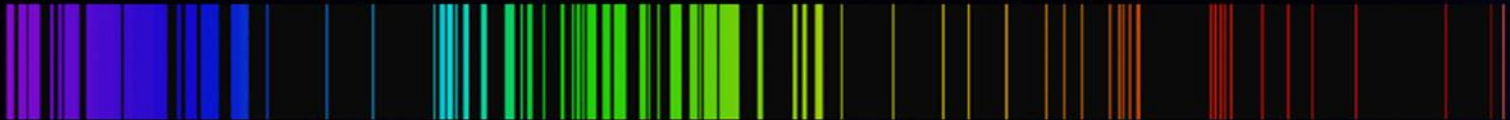

Unable to sleep

In the 1850s, Bunsen and Kirchhoff discovered that the spectral lines are unique to each element. In a letter to a colleague, Bunsen wrote:

At present Kirchhoff and I are engaged in a common work which doesn't let us sleep ... Kirchhoff has made a wonderful, entirely unexpected discovery in finding the cause of the dark lines in the solar spectrum.

The discovery enabled the determination of the Sun's and stars' composition and also the discovery of new elements.



Robert Wilhelm Bunsen 1811 - 1899
Gustav Robert Kirchhoff 1824 - 1887



Spectral lines of chemical elements

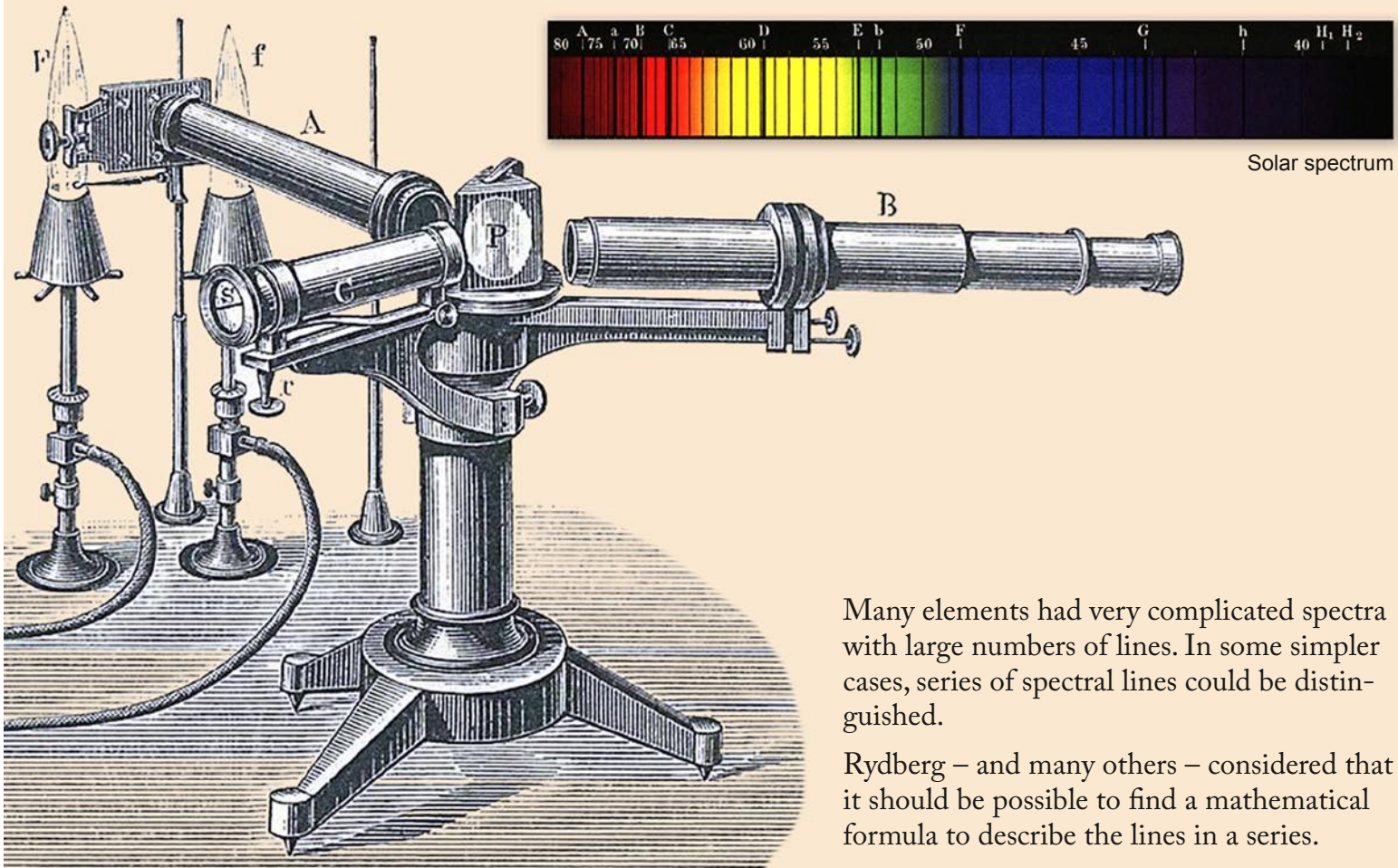

Solar spectrum

Many elements had very complicated spectra with large numbers of lines. In some simpler cases, series of spectral lines could be distinguished.

Rydberg – and many others – considered that it should be possible to find a mathematical formula to describe the lines in a series.

Spectral series

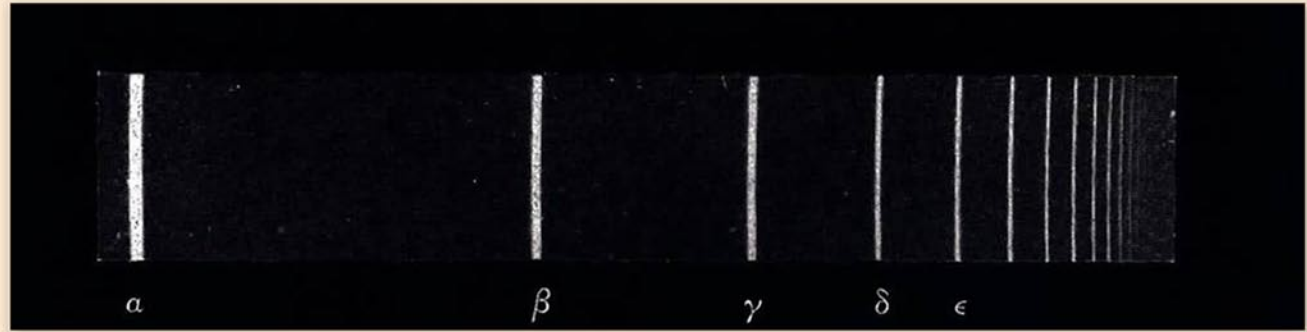

The simplest series of spectral lines had been observed in hydrogen.

Rydberg's interest was in studying periodic properties of the elements. He therefore chose to simultaneously study spectra from a number of elements that belonged to the same group in the periodic table, for example the alkali metals Li, Na, K.

These have a more complex structure than hydrogen and a number of series could be distinguished in each element.

After extensive experiments with different mathematical equations, he was able to present his first results in 1887 in a report to the Royal Swedish Academy of Sciences.

Reflex	Gruppe I. — R'0	Gruppe II. — R0	Gruppe III. — R'0*	Gruppe IV. RH* R0*	Gruppe V. RH* R'0*	Gruppe VI. RH* R0*	Gruppe VII. RH R'0'	Gruppe VIII. — R0*
1	H=1							
2	Li=7	Be=9,4	B=11	C=12	N=14	O=16	F=19	
3	Na=23	Mg=24	Al=27,3	Si=28	P=31	S=32	Cl=35,5	
4	K=39	Ca=40	—=44	Ti=48	V=51	Cr=52	Mn=55	Fe=56, Co=59, Ni=59, Cu=63.
5	(Cu=63)	Zn=65	—=68	—=72	As=75	Se=78	Br=80	
6	Rb=85	Sr=87	?Yt=88	Zr=90	Nb=94	Mo=96	—=100	Ru=104, Rh=104, Pd=106, Ag=108.
7	(Ag=108)	Cd=112	In=113	Sn=118	Sb=122	Te=125	J=127	
8	Cs=133	Ba=137	?Di=138	?Ce=140	—	—	—	—
9	(—)	—	—	—	—	—	—	—
10	—	—	?Er=178	?La=180	Ta=182	W=184	—	Os=195, Ir=197, Pt=198, Au=199.
11	(Au=199)	Hg=200	Tl=204	Pb=207	Bi=208	—	—	—
12	—	—	—	Th=231	—	U=240	—	—

Series formula

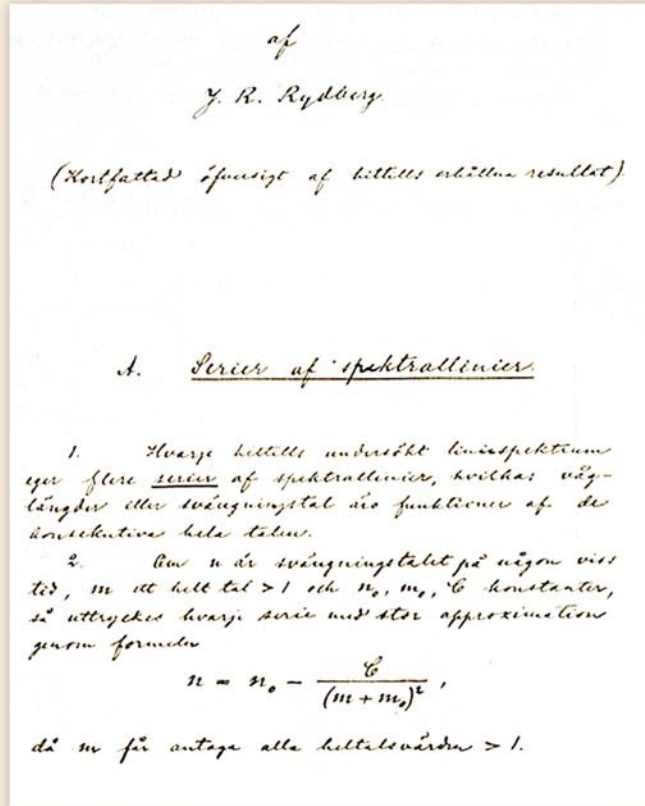

Rydberg's report to the Royal Swedish Academy of Sciences.

In Lund Rydberg described his work at a meeting of the Matematisk-Fysiska Föreningen (Mathematics & Physics Association) in 1888.

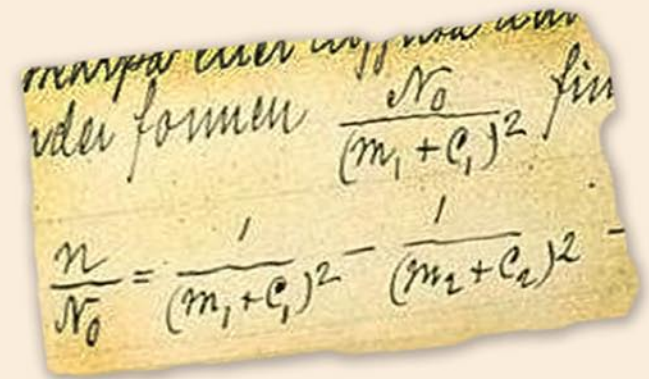

Today the formula is written as follows:

$$\frac{1}{\lambda} = R \left(\frac{1}{(n + c_1)^2} - \frac{1}{(m + c_2)^2} \right)$$

R, n, c_1 and c_2 are constants in a series of lines. n and m are whole numbers, where m is greater than n . If m increases in intervals, the formula describes the wavelength λ of the lines in a series.

The Rydberg constant

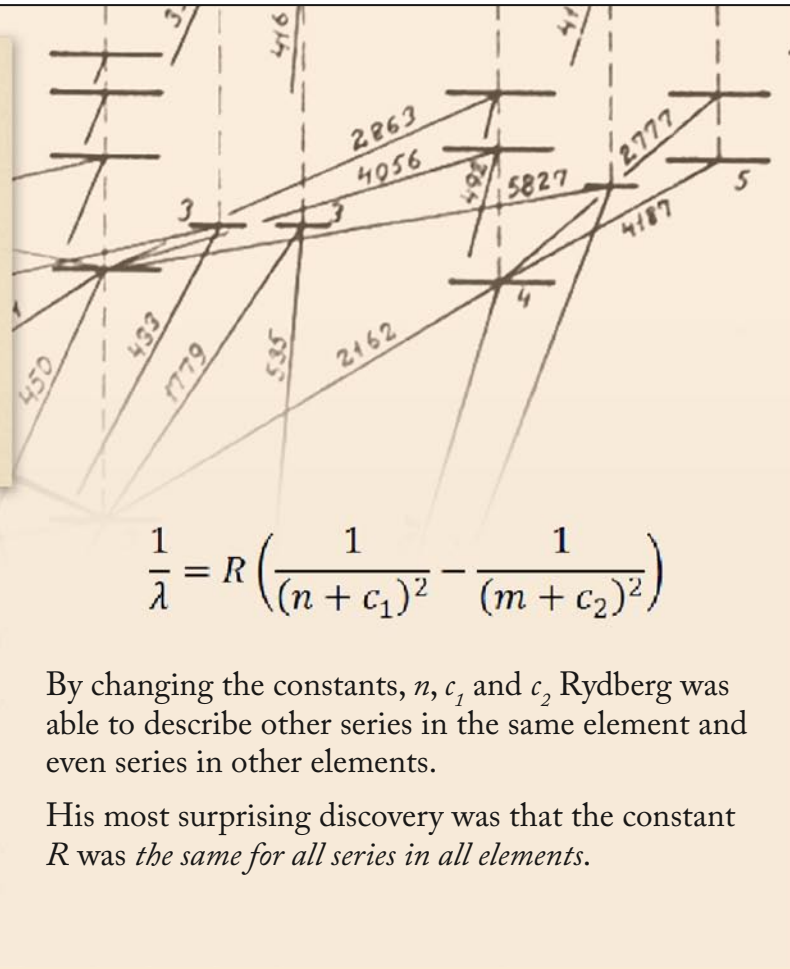
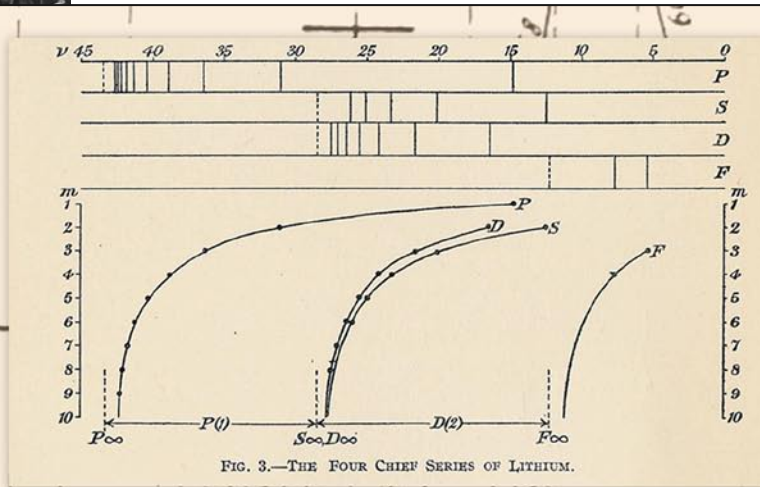

$$\frac{1}{\lambda} = R \left(\frac{1}{(n + c_1)^2} - \frac{1}{(m + c_2)^2} \right)$$

By changing the constants, n , c_1 , and c_2 , Rydberg was able to describe other series in the same element and even series in other elements.

His most surprising discovery was that the constant R was *the same for all series in all elements*.



Bohr's model of the atom

In 1913, by introducing two simple *postulates* (theoretical predictions), Niels Bohr successfully derived a theoretical formula for the hydrogen spectrum which had the same form as Rydberg's formula (with the constants $c_1 = c_2 = 0$).

The theory also gave a value for Rydberg's constant R that was in good agreement with Rydberg's experimental value.

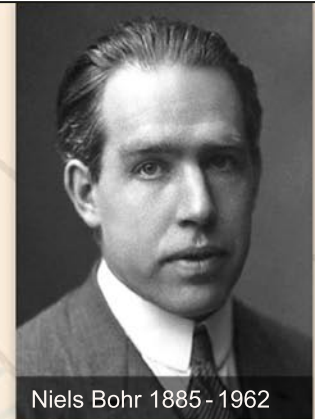

Niels Bohr 1885 - 1962

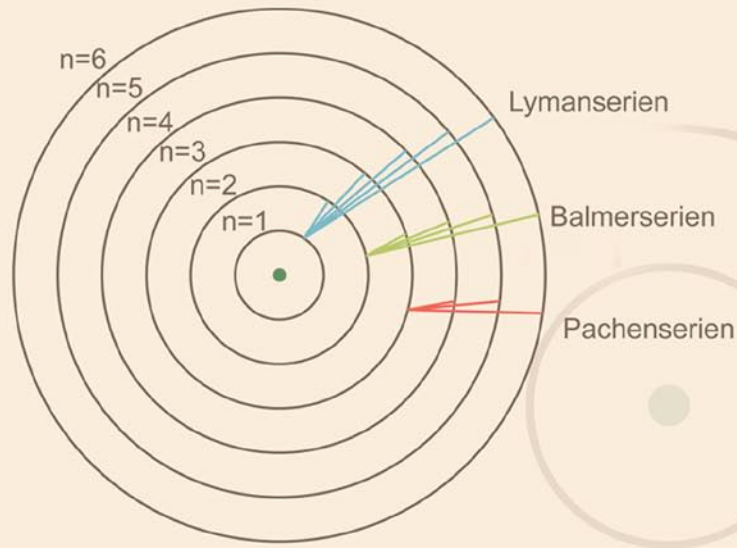

Rydberg and quantum physics

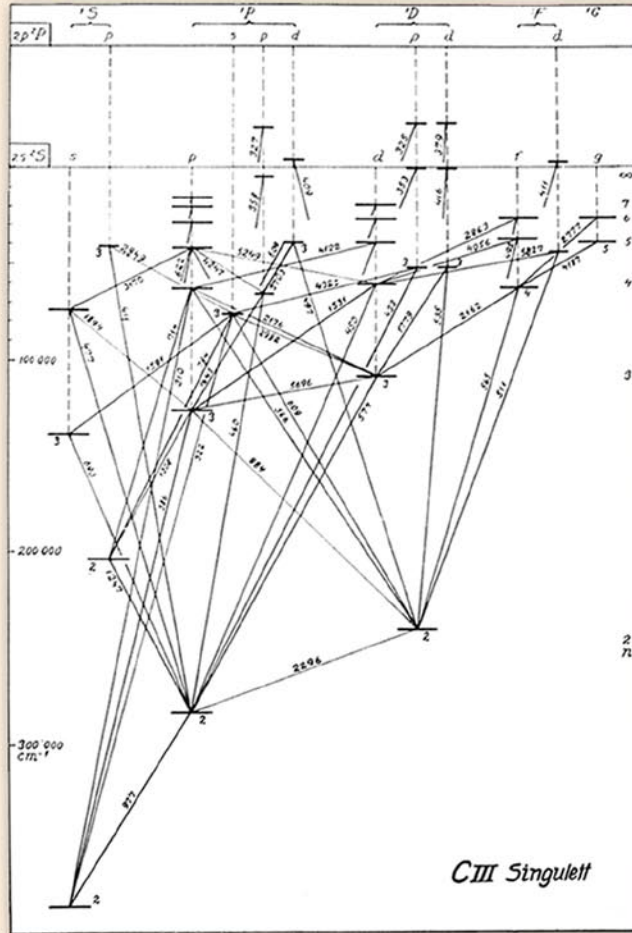

The discovery of the series formula for simple spectra showed that $1/\lambda = \sigma$ is the important quantity in spectra. Quantum physics later showed that σ is proportional to the photon energy.

$$E = h\nu = hc\sigma$$

The formula shows that a spectral line can be written as the difference between two terms. This is known as *the Rydberg-Ritz combination principle*. Quantum physics later showed that the terms are the atom's energy levels.

$$R_{\infty} = \frac{m_e e^4}{8\epsilon_0^2 h^3 c}$$

What is now called the *Rydberg constant* was shown to be a combination of other physical constants. Because it can be measured very accurately using spectroscopy, it is fundamental for the determination of other physical constants.

Back to the periodic table

The periodic table was always Rydberg's main interest. He continued to test different methods to explain the periodic regularities and tried to arrange the table in different ways.

The final explanation of the periodicity was found with Wolfgang Pauli's postulate; that the quantum numbers of two electrons in a system cannot all be the same.

The postulate is known as *the exclusion principle* and was presented in 1925, six years after Rydberg's death.

One of Rydberg's attempts to explain the periodic regularities.

My goal in life

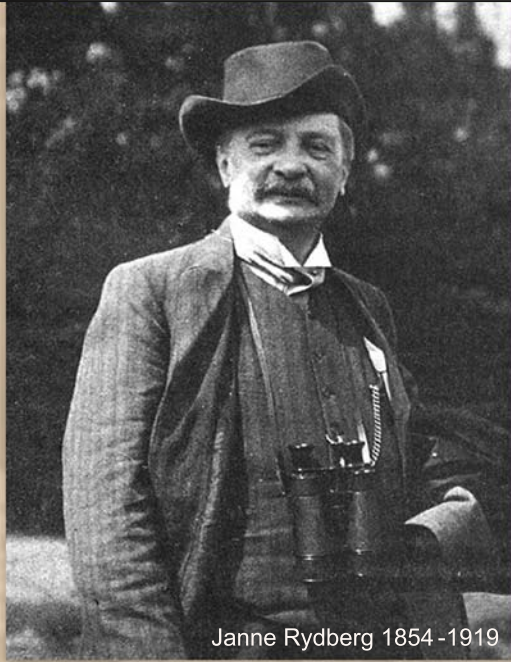

Janne Rydberg 1854 -1919

At the age of 47, recently appointed extraordinary professor, Rydberg wrote in his diary:

It appears obvious to me, when I think about the ways I was led to this work, which was to become my goal in life, that all the difficulties and setbacks have been just as necessary to facilitate the work as the successes I have had, or even more necessary ...

... The one who meets obstacles on the path he first chose and is thus led onto other possible paths has a much more secure path than the one for whom the entire field lies free and open so that he doesn't know which way he may go.

The Rydberg conference

In 1954, to commemorate the 100th anniversary of Rydberg's birth, a conference was held in Lund. It was attended by a number of the world's leading atomic physicists, including seven Nobel Prize Laureates – three who had already been awarded the prize and four who would go on to receive it.

Niels Bohr gave a presentation entitled:
Rydberg's discovery of spectral laws.

Wolfgang Pauli contributed with:
Rydberg and the periodic system of the elements.

Niels Bohr (1922)
Wolfgang Pauli (1945)
Frits Zernike (1953)
Alfred Kastler (1966)
Gerhard Herzberg (1971) (Chemistry)
Aage Bohr (1975)
Ben Mottelson (1975)

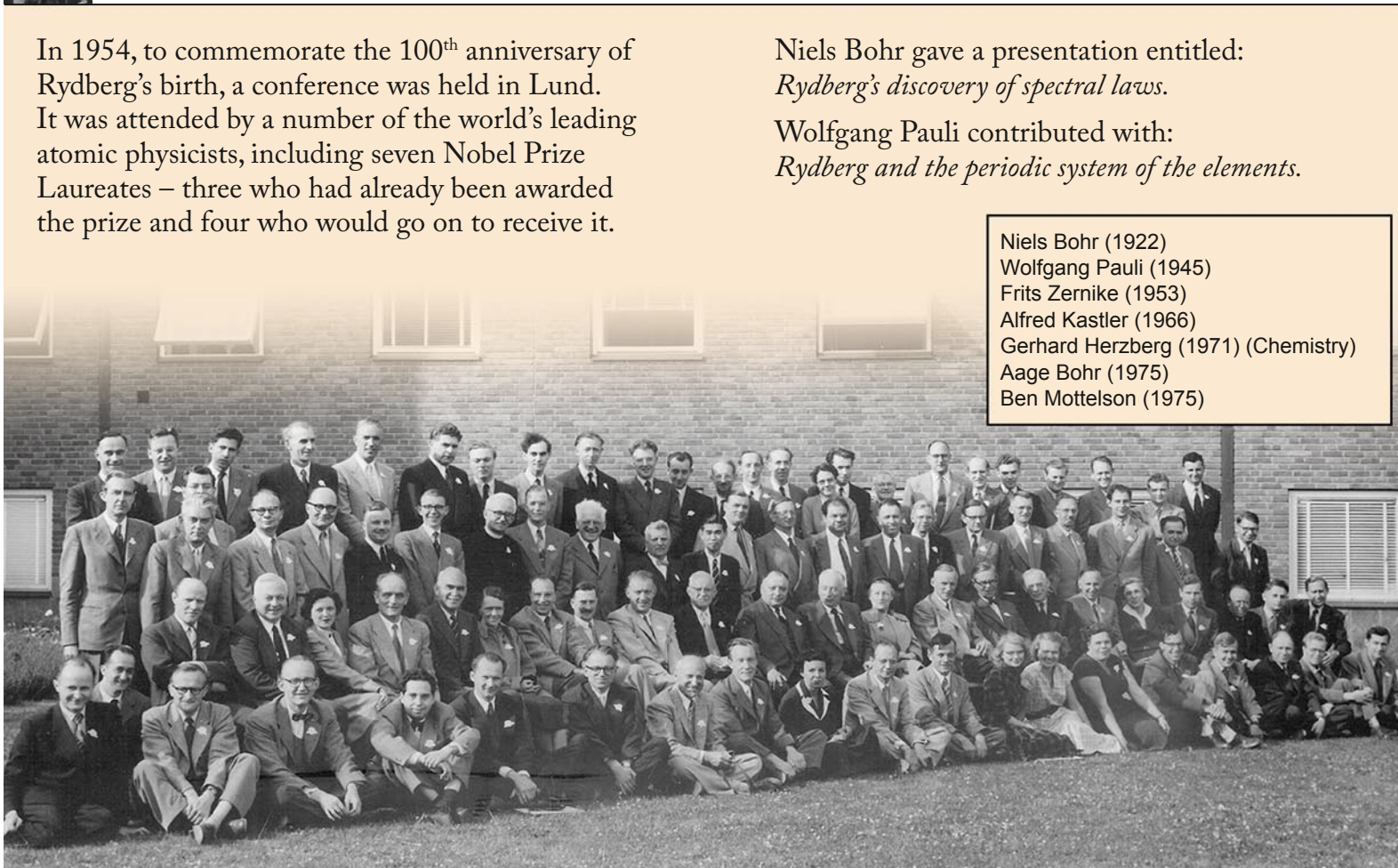



The Nobel Prize Laureate who disappeared

How a man from Örebro was awarded the Nobel Prize thanks to a lucky eye for design and great attention to detail.



Assistant and Reader

Manne Siegbahn, born in 1886 in Örebro, was registered as a student at Lund University at the age of 19 and began studying physics.

In the same year he was appointed teaching assistant and a few years later assistant to Janne Rydberg. He turned out to have a great talent for physics and gained a PhD in 1911 at the age of 25 with a thesis on methods of measuring magnetic fields.

Manne Siegbahn was soon given on a leading position at the department. Rydberg was prone to illness and, Siegbahn substituted for him.



Manne Siegbahn 1886 - 1978

Rydberg's successor

At that time there were many unsolved mysteries in physics research. The discovery of X-rays and radioactivity and the work of Planck and Einstein led the research onto new lines.

After completing his PhD in 1911, Siegbahn focused his research on X-rays. During the summer vacations he travelled to leading departments of physics around Europe – Göttingen, Munich, Heidelberg, Paris and Berlin – to acquaint himself with current work.

When Rydberg retired in 1919, Siegbahn was internationally renowned as one of the leaders in his field and he was appointed directly as Rydberg's successor without having to apply for the position.



Mysterious rays



On one of his European trips, Siegbahn visited Professor Wilhelm Röntgen. Just over ten years previously, Röntgen had reported the discovery of a mysterious, penetrating type of ray.

On the top floor of the Department of Physics in Würzburg, Röntgen had his private quarters, and on the ground floor was the department laboratory.

On the afternoon of 8 November 1895, Röntgen went down to his laboratory in Würzburg and here he describes what he saw:

[...] The vacuum tube is surrounded by a fairly close-fitting shield of black paper; it is then possible to see, in a completely darkened room, that paper covered on one side with barium platinocyanide lights up with brilliant fluorescence when brought into the neighbourhood of the tube, whether the painted side or the other be turned towards the tube. The fluorescence is still visible at two metres distance.



Wilhelm Röntgen 1845 - 1923

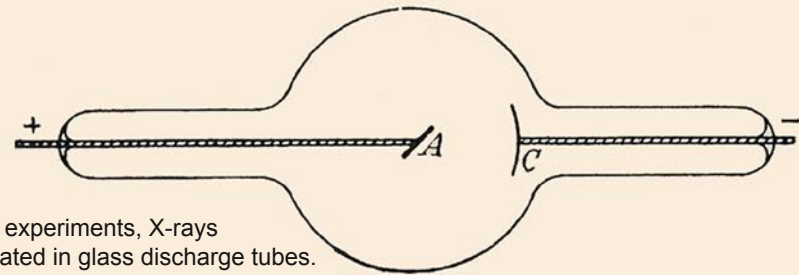

In the early experiments, X-rays were generated in glass discharge tubes. The radiation was emitted from the anode (A on the drawing).

X-rays

Soon Röntgen could show that the rays not only penetrated paper screens, but also various types of material. He sent his report of these results to around 100 colleagues as a New Year's greeting and soon after it was being cited in the world press.

The discovery of X-rays led to intensive research around the world and Wilhelm Röntgen was awarded the first Nobel Prize for Physics in 1901.

The first medical X-ray image, taken by Professor Wilhelm Röntgen of his wife Anna Bertha Ludwig's hand with wedding ring.



Wavelength measurements

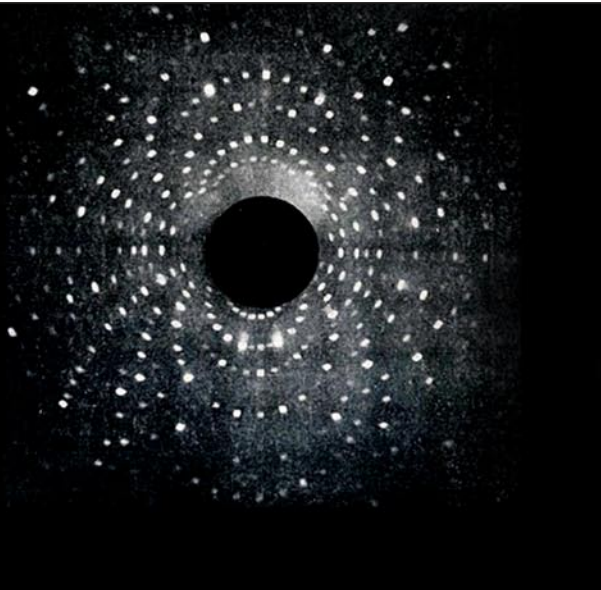

German physicist Max von Laue proposed an important experiment, which was carried out by the two German physicists Walter Friedrich and Paul Knipping in 1912.

The experiment showed that if X-rays were passed through a crystal of the mineral zinc blende and then hit a photographic plate, a diffraction pattern could be observed. This was the definitive proof that the X-rays are waves.

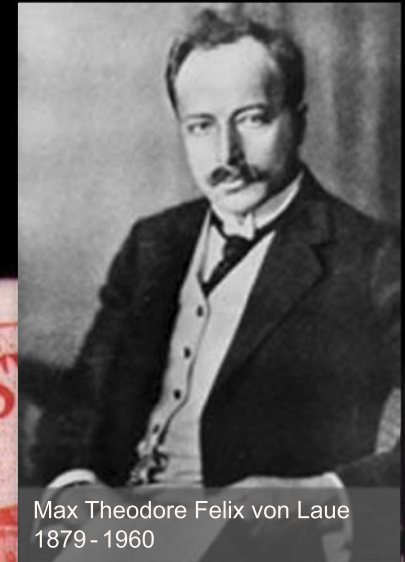

Max Theodore Felix von Laue
1879 - 1960



Bragg's law

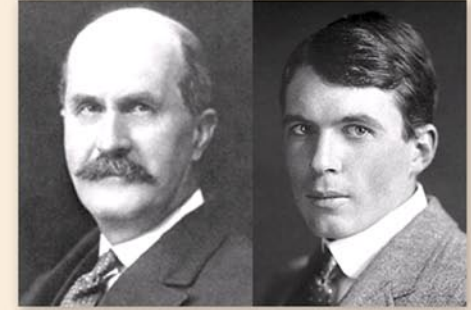
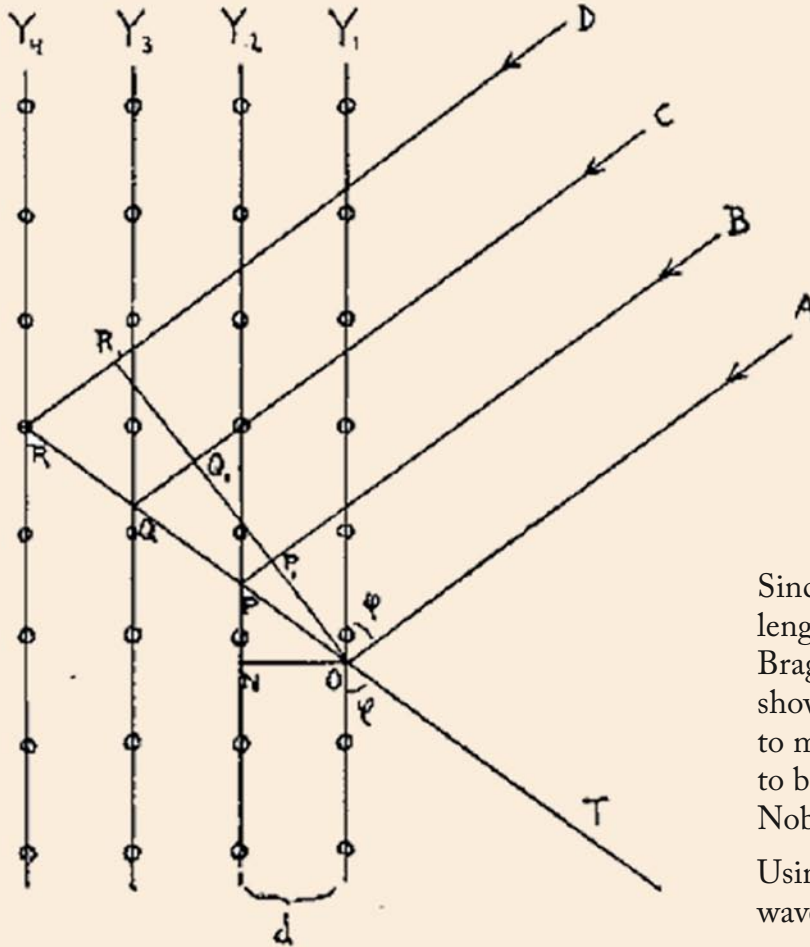

Sir William Henry Bragg
and William Lawrence Bragg

Since X-rays behave like a wave motion, their wavelength can be measured. In 1913 Sir William Henry Bragg and William Lawrence Bragg (father and son) showed how the reflection in a crystal could be used to measure wavelengths. The formula for this came to be known as Bragg's law. They received the 1915 Nobel Prize for Physics for this discovery.

Using Bragg's law it became possible to determine the wavelength of X-rays.

In the shadow of the war

In 1914 Englishman Henry Moseley had discovered a fundamental connection between atomic number and wavelength in the X-ray spectra of various elements. He had found that if the root of the frequency ν or $\sqrt{(1/\lambda)}$ is plotted against the element's ordinal number in the periodic table, a straight line is produced. Using this type of diagram and with the help of Niels Bohr's theories, Moseley was able to draw the conclusion that the atomic number and the charge number of the nucleus, Z , were the same number. Atomic numbers became meaningful.

In August 1915 Moseley was killed in action at Gallipoli.



British artillery opens fire during the Battle of Gallipoli, June

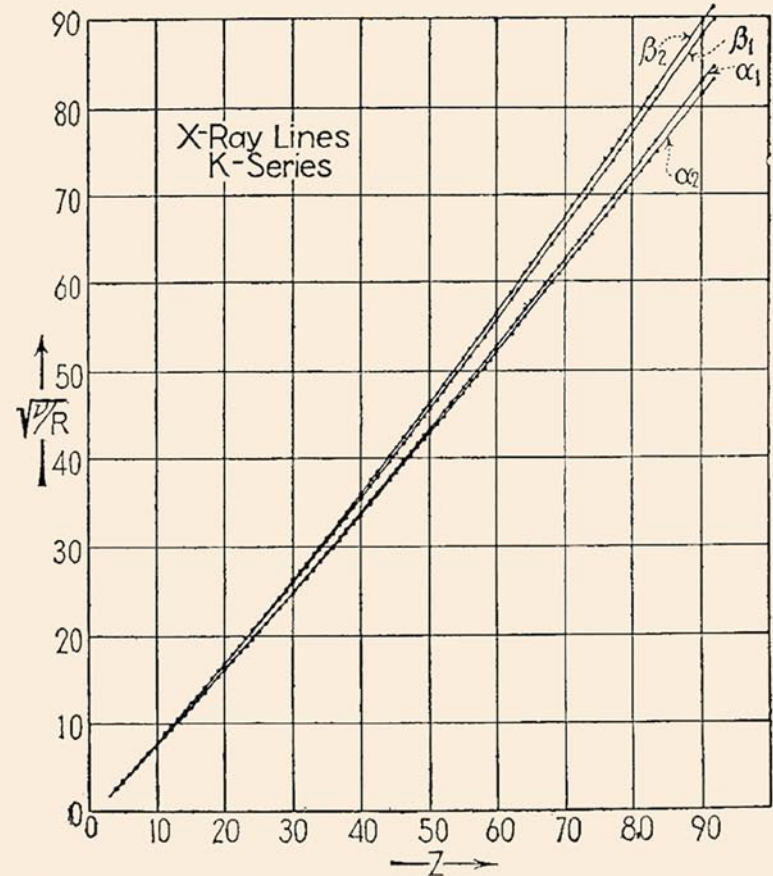

FIG. 16.4a.—Moseley law for K-series x-ray lines.

X-ray tubes and spectrometers



Abb. 53a.



Abb. 53b.

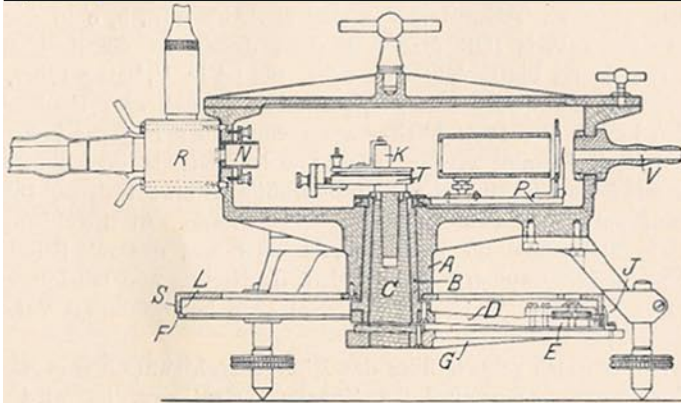

In Lund, Manne Siegbahn had followed the developments in the new research field that opened up. Siegbahn realised that Moseley's work should be continued and expanded to more elements and other wavelength regions.

Spectrometers with the entire radiation path in a vacuum made it possible to observe spectra on longer wavelengths than previously.

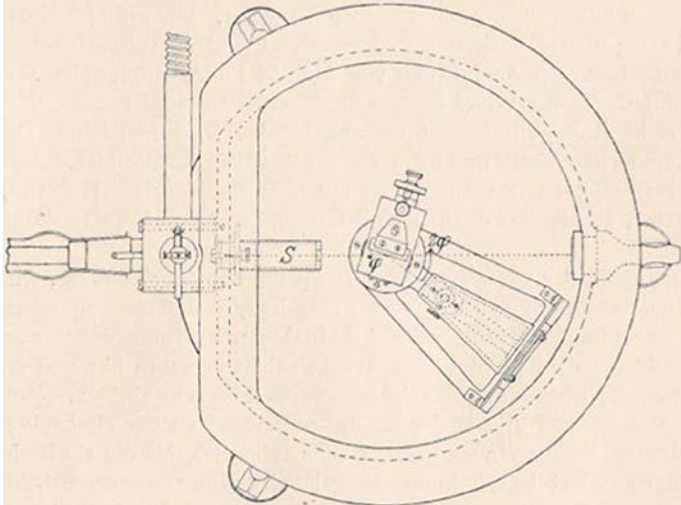
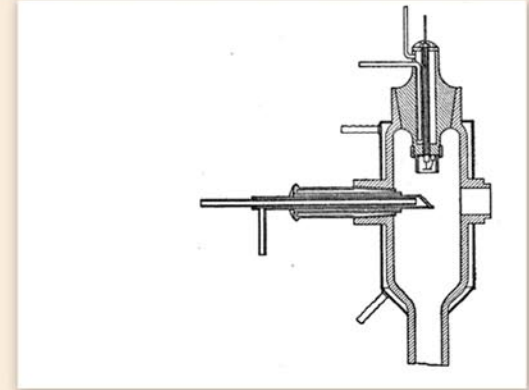
With a new method, Siegbahn was also able to increase the accuracy of the measurements by over 100 times. With higher resolution, many new components were discovered in the groups of lines that had previously been observed.

Designers and instrument makers

One of Siegbahn's pupils, Arvid Leide, wrote that the successes were due to:

... Siegbahn's personal qualities as an ingenious and inspiring teacher, his scientific intuition and his lucky eye for design.

X-ray tubes, spectrometers and vacuum pumps were manufactured at the department, initially by caretaker AL Pedersen and later by a specially employed precision instrument maker AS Ahlström.

Alfred S Ahlström, had his workshop on Stora Fiskaregatan 8 in a dark room in the yard. The same room contained workshop, storeroom, kitchen and bed.

He had introduced a flat rate and all repairs cost 1 krona and 25 öre regardless of how long they took to carry out. If the repair was particularly amusing or interesting then the work was free.



Precision instrument maker Alfred Severin Ahlström, 1858-1922 in his combined home and workshop on St. Fiskaregatan 8.

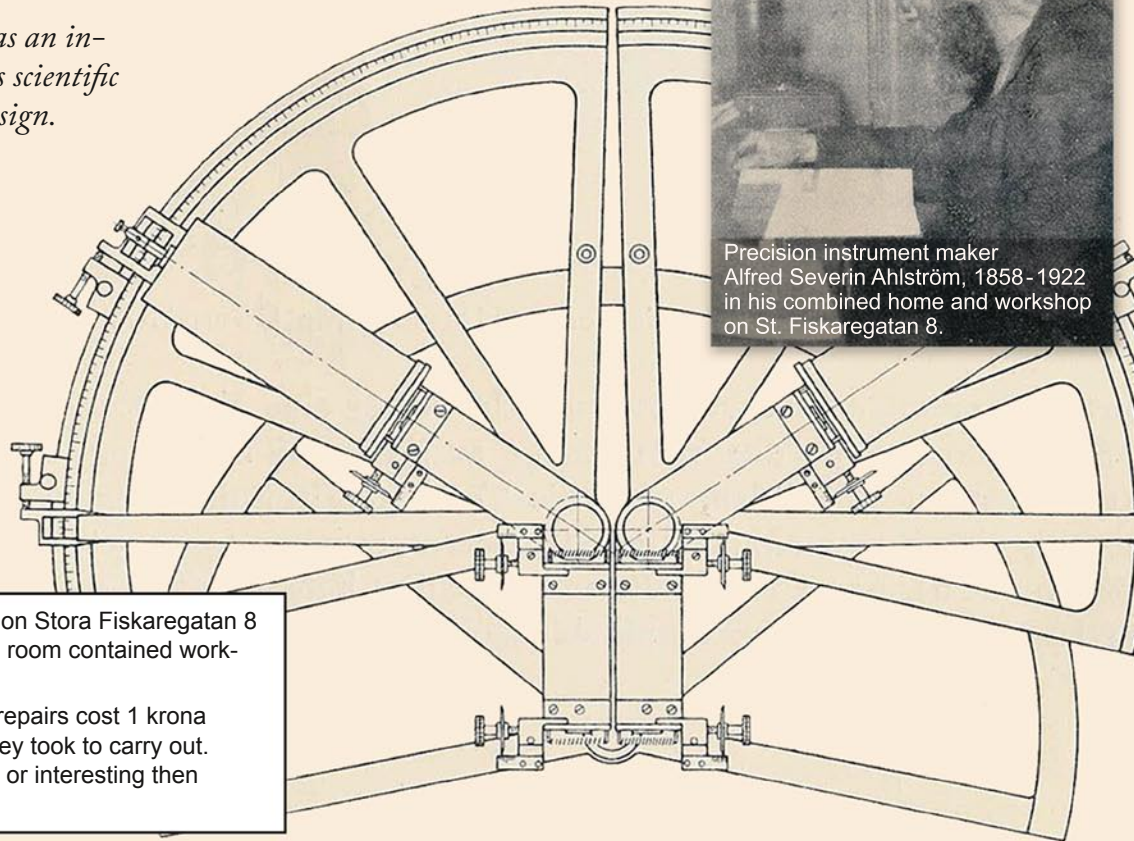

New discoveries

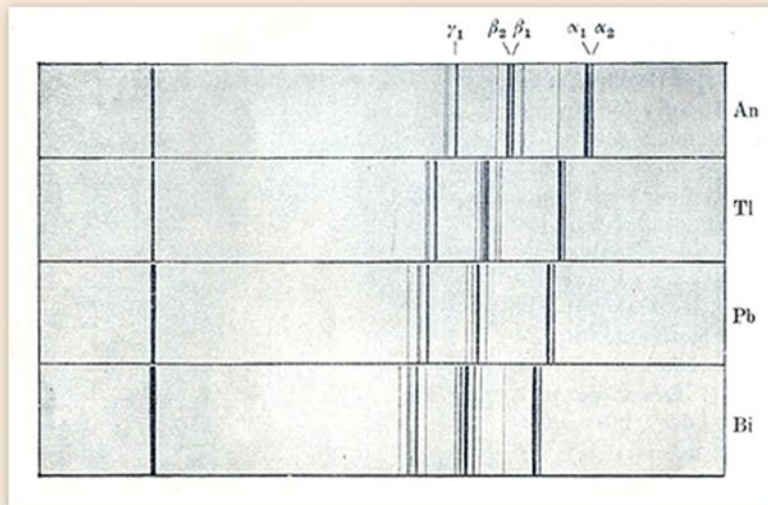

Siegbahn's own photographic spectra with the *L* series in four different elements.

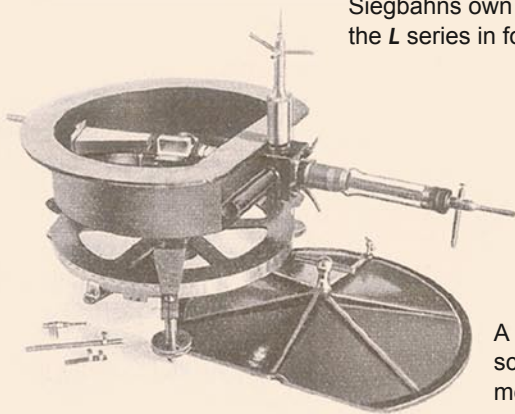

A new measurement method and the precision scale engraved on the lower part of the spectrometer, gave the great improvement in accuracy.

Manne Siegbahn had a rare ability to attract talented doctoral students. In the years 1914–1925, no fewer than 15 doctoral theses were published, several of which were of epoch-making significance. The projects comprised systematic studies and precision measurements of X-ray spectra throughout the periodic table.

Two groups of spectral lines had previously been observed in each element, called the *K* series and the *L* series. Using the new spectrometers, it was found that the *L* series contained many more lines than had previously been observed. In 1916 Siegbahn discovered a new group of lines at longer wavelengths, which became known as the *M* series.

Bohr's model of the atom

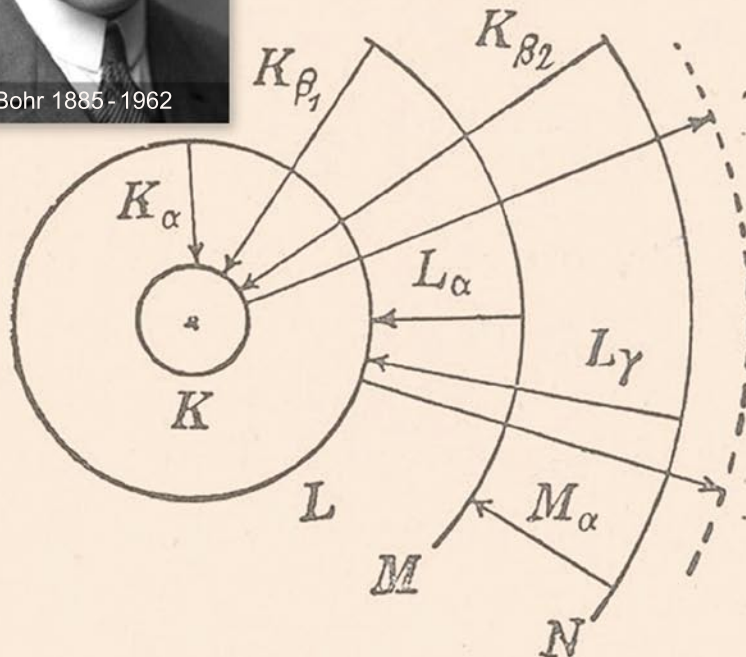

In 1913 Niels Bohr had presented his model of the atom. With this model it was possible in principle to explain how the characteristic X-ray lines came about. In the X-ray tube, an electron is knocked out of an inner electron shell. The space is filled by an electron from an outer shell and the surplus energy is emitted as an X-ray.

Bohr's model could also be used to explain the connection between wavelengths and atomic numbers discovered by Moseley.

However, the many new spectral lines observed with Siegbahn's high-resolution spectrometers could not be explained.

Sommerfeld's ellipses

In order to improve the model of the atom, Arnold Sommerfeld (German mathematician and theoretical physicist) assumed that the electrons moved in elliptical trajectories around the atomic nucleus instead of in Bohr's circular trajectories. Sommerfeld's elliptical electron trajectories assumed that many of the X-ray lines – as observed – were divided into a number of components.

Now precision measurements were needed that could only be performed in Lund. In order to access accurate data, Arnold Sommerfeld corresponded with Manne Siegbahn. The eyes of the atomic physicists were on Lund.

In a general presentation that Siegbahn held in autumn 1918, he said:

Based on our precise measurements, Sommerfeld has proved that his formula is generally correct. Measurements now exist that make it possible to check the value of his formula even more precisely.

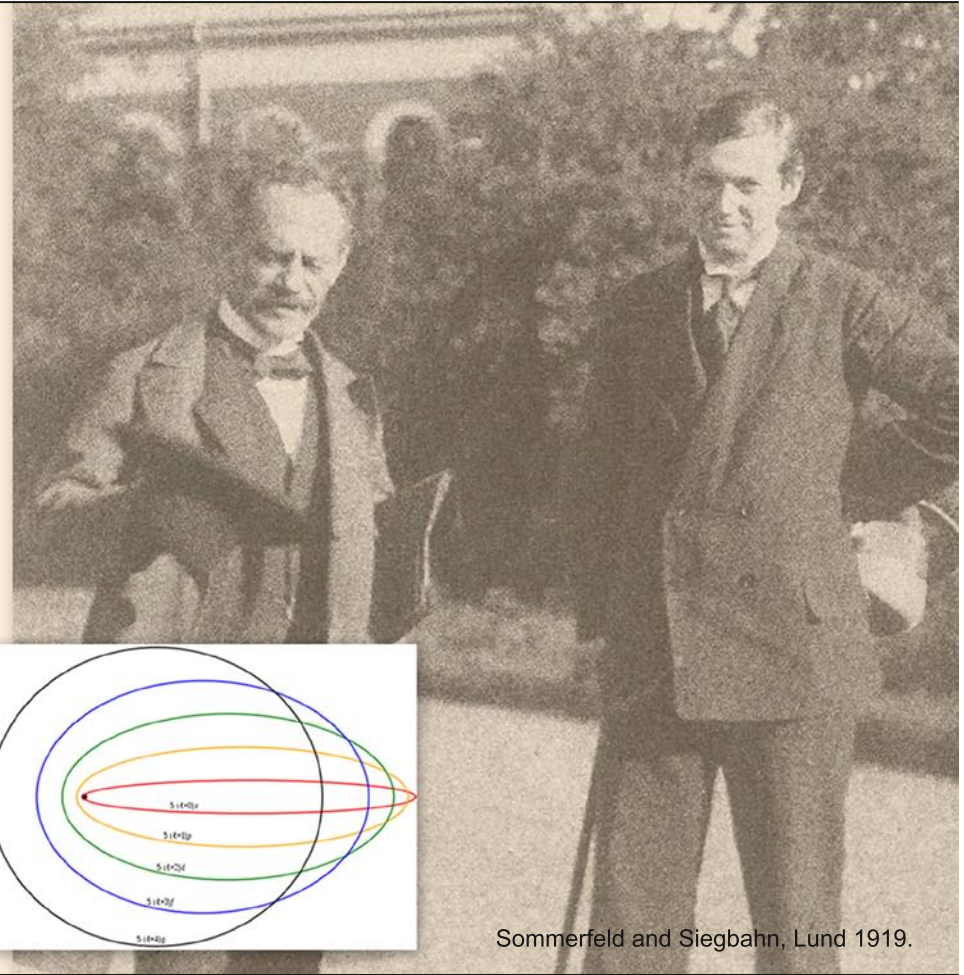
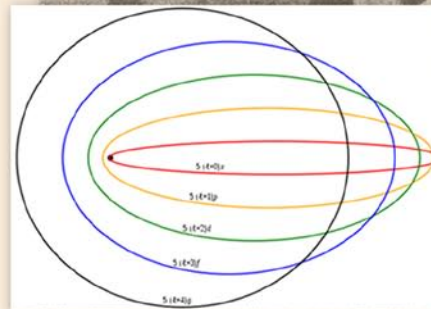

Sommerfeld and Siegbahn, Lund 1919.

International attention

The new precision measurements and Siegbahn's international contacts led to researchers from many countries visiting Lund to learn about the new technique. In 1919 an international conference was held in Lund with leading atomic physicists.



Arnold Sommerfeld (1), Niels Bohr (2), and Manne Siegbahn (3) on the bottom step outside the old Physics building at Hyphoffslyckan at Sölvegatan 2.

Stäng dörren!

Close the door !

Zavřete dveře !

Luk døren !

إغلاق !

סגור את הדלת !

It is claimed that outside the darkroom where the spectrograms were developed there was a sign to which visiting researchers added over time.

New effects

Manne Siegbahn's research meant a lot for the development of the new quantum physics. During these years, precision measurements of the energy of X-rays were needed for the theories developed during the 1920s to be tested and shown to be successful.

The greatly improved accuracy also led to new effects being observed. Siegbahn's pupils Johan Bergengren and Axel Lindh discovered that the electrons' chemical bonds affected the absorption of X-rays, a discovery that paved the way for new methods of analysis that were important to the research that is carried out nowadays at the MAX IV Laboratory.

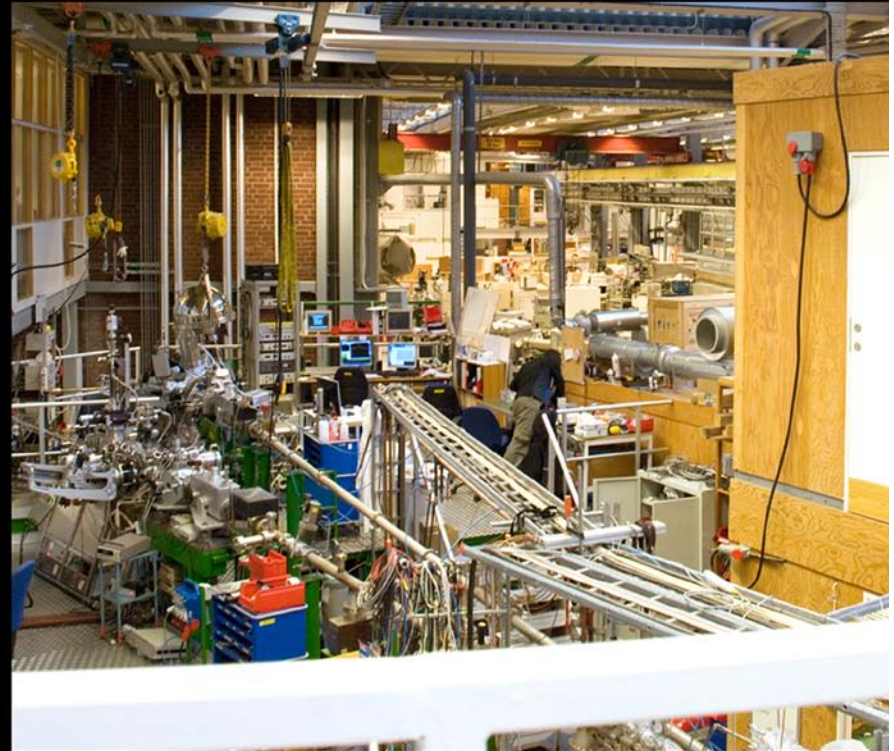

Inside the experimental hall at MAX-lab, (later succeeded by MAX IV), the national synchrotron radiation laboratory in Lund.

Nobel Prize



In 1922, the chair of physics in Uppsala became vacant, and, as previously in Lund, Siegbahn was offered the post without having to apply. He accepted and left Lund in 1923.

In 1925 Manne Siegbahn was awarded the dormant 1924 Nobel Prize for Physics *for his discoveries and research in the field of X-ray spectroscopy.*

In 1936 the Royal Swedish Academy of Sciences established a research institute for physics in Stockholm and Manne Siegbahn was appointed head of the institute. The primary focus of the research there was on nuclear physics.

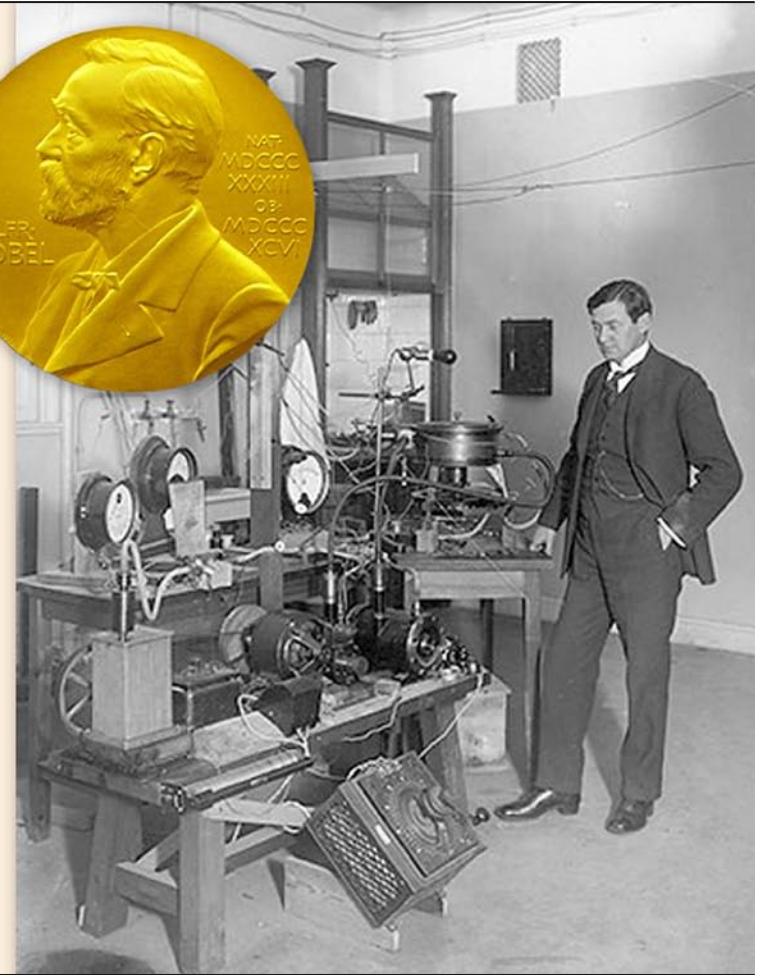

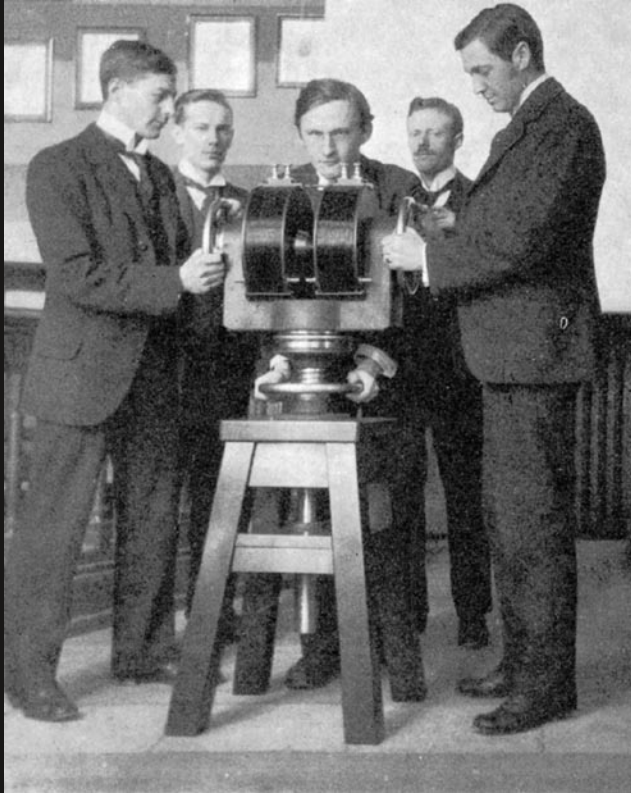

Successful students

Licentiates, doctoral students,
and one lecturer, 1900 - 1930.

The dream of flying ...

Enoch Thulin was an important, and unconventional, student of Professor Janne Rydberg. He was born in 1881 in the small village of Simris, on the south coast of Sweden. Already as a child, he was fascinated by flying, and he began his studies at the Department of Physics in Lund in 1900.

As a boy I dreamed about flying. I built my first flying machine at school. My university studies were concerned with the theoretical and technical aspects of flying, and I was present at the very first flights in Europe. I have always been convinced that flying would revolutionize travel. The future of human culture may even rest on it.

Apart from anything else, flying is fun!

Quote from *Enoch Thulin: Forskare, flygare, företagare*, by Jan Wærnberg.



Enoch Thulin 1881 - 1919

... comes true



Enoch Thulin in a Thulin B, in the harbour at Mölle in 1917.

Janne Rydberg and Enoch Thulin worked together to develop a programme for a licentiate study in aerodynamics. This led to Thulin's, partially experimental, doctoral thesis, entitled, *On the Air Resistance of Thin Sheets at Varying Velocity*, which he defended in 1912, and which proved to be important in the understanding of aerodynamics. His examiner was Professor Rydberg himself, who awarded Thulin *a Pass with Distinction*.



The industrialist

In 1914, Enoch Thulin founded *Enoch Thulins Aeroplanfabrik*, which expanded rapidly, and at its peak had almost 800 employees. He employed several scientists from the Department of Physics.

The company manufactured engines and various models of aeroplanes designed by its engineers, and was the first aeroplane manufacturer in Sweden. Four different kinds of planes and three rotary engines were made at the factory.

Following the death of Enoch Thulin in a flying accident in 1919, the production of aircraft at the company ceased.



Enoch Thulin's fatal crash on 14 May 1919, in one of the slipways at the Öresund Shipyard.

New physics

Gudmund Borelius started his studies in Lund with Professor Janne Rydberg as his supervisor. He presented his doctoral thesis, entitled *The Surface Potentials of Solutions in Contact with Insulators*, in 1915.

That same year, Professor Manne Siegbahn became head of the Department, and Borelius took over Siegbahn's position as teaching assistant.

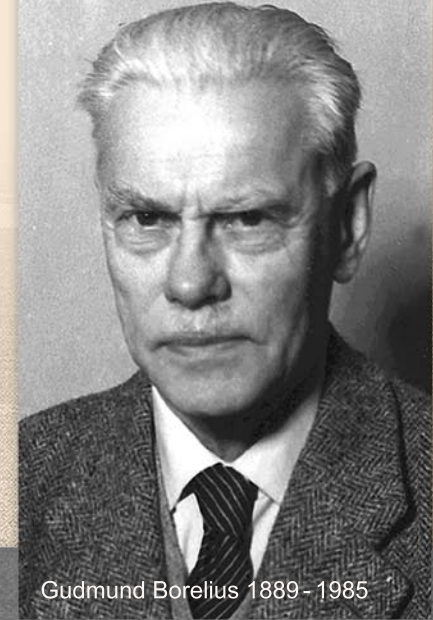

Gudmund Borelius 1889 - 1985

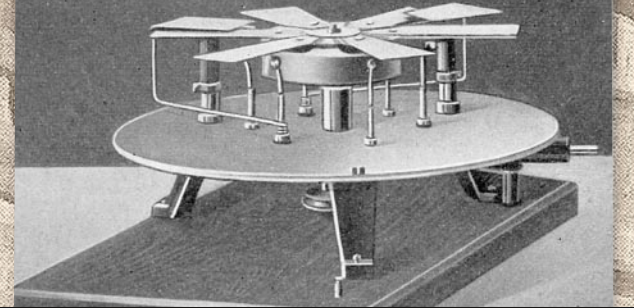

The Swedish father of solid state physics

In 1922, Borelius became Professor of Physics at the Royal Institute of Technology in Stockholm. His field of research was solid state physics, and Borelius is considered to be the founder of the subject in Sweden. As professor at the Royal Institute of Technology he created the new subject of engineering physics in undergraduate teaching.



In his spare time, Borelius liked to draw, and at the age of 18 he illustrated the children's story *Three Red Apples*, which was published in a children's magazine in March 1907.

Talented students

Manne Siegbahn had an exceptional ability to attract talented students. He could thus delegate his teaching duties to his assistants, enabling him to concentrate on research and supervising doctoral students.

The influx of students was high at the beginning of the 1910s due to locally administered middle schools being given the same status as state-run grammar schools. This led to large groups of students for Siegbahn to enthuse, and who later had plenty of opportunities to carry out research when the intake of students fell.

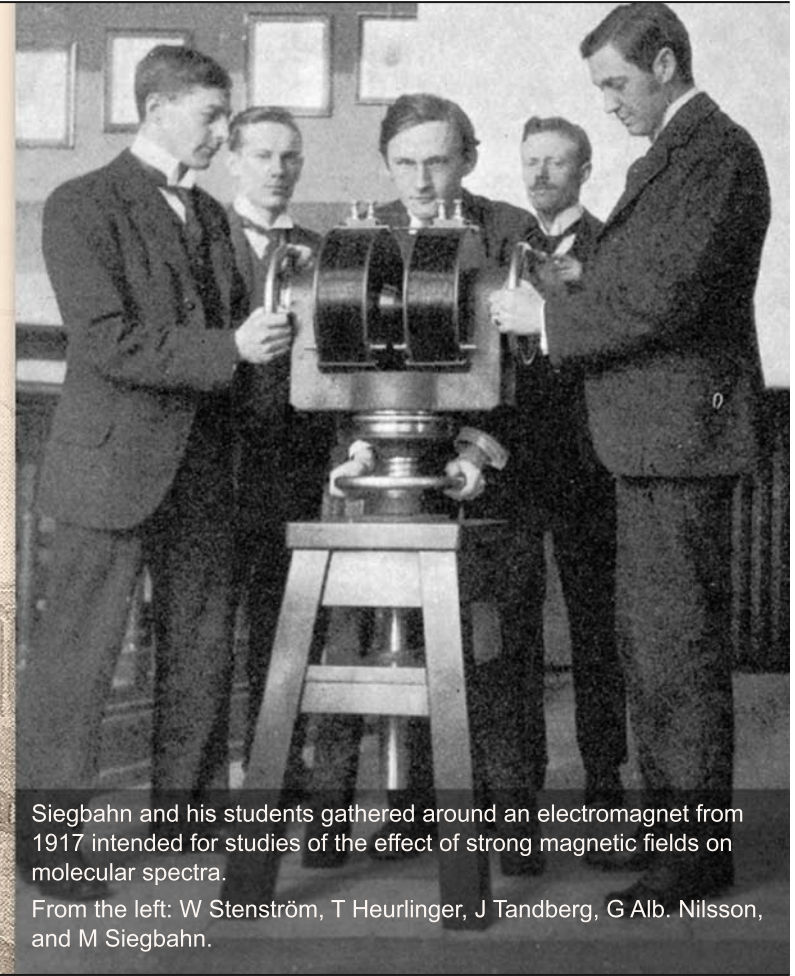

Siegbahn and his students gathered around an electromagnet from 1917 intended for studies of the effect of strong magnetic fields on molecular spectra.

From the left: W Stenström, T Heurlinger, J Tandberg, G Alb. Nilsson, and M Siegbahn.

Who was J Bergengren?

J Bergengren was a lecturer in mathematics and physics, but he had problems securing a permanent position. In order to broaden his qualifications, he decided to undertake further studies in physics at the age of 40, and applied for an experimental course. Upon completing the course, he was required to carry out a project, and he contacted Manne Siegbahn, who was thirteen years his junior. Siegbahn suggested that he study the absorption of X-rays by different forms of phosphorus and phosphoric acid.

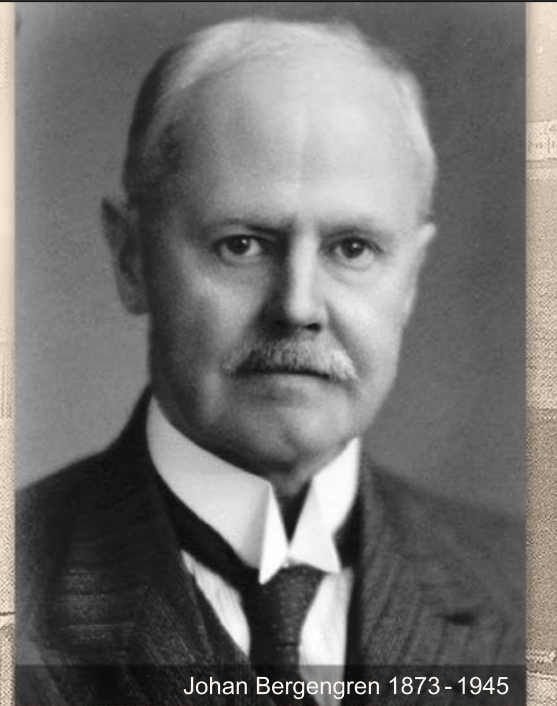

Johan Bergengren 1873 - 1945

A historic project

Über die Röntgenabsorption des Phosphors.

Von **J. Bergengren.**

Erste Mitteilung. (Eingegangen am 16. Oktober 1920.)

Bergengren's work was published in *Zeitschrift für Physik* in 1920.

Bergengren's project showed that it was possible to study the chemical binding of phosphorus atoms using X-rays. This was a historic result, which today still forms the basis of chemical analysis using X-rays. Although he had a doctorate in mathematics, he was a novice in experimental physics, but he became internationally known through this single physical study. Thanks to his new skills, he was appointed lecturer in mathematics and physics at Lund University.



X-ray absorption

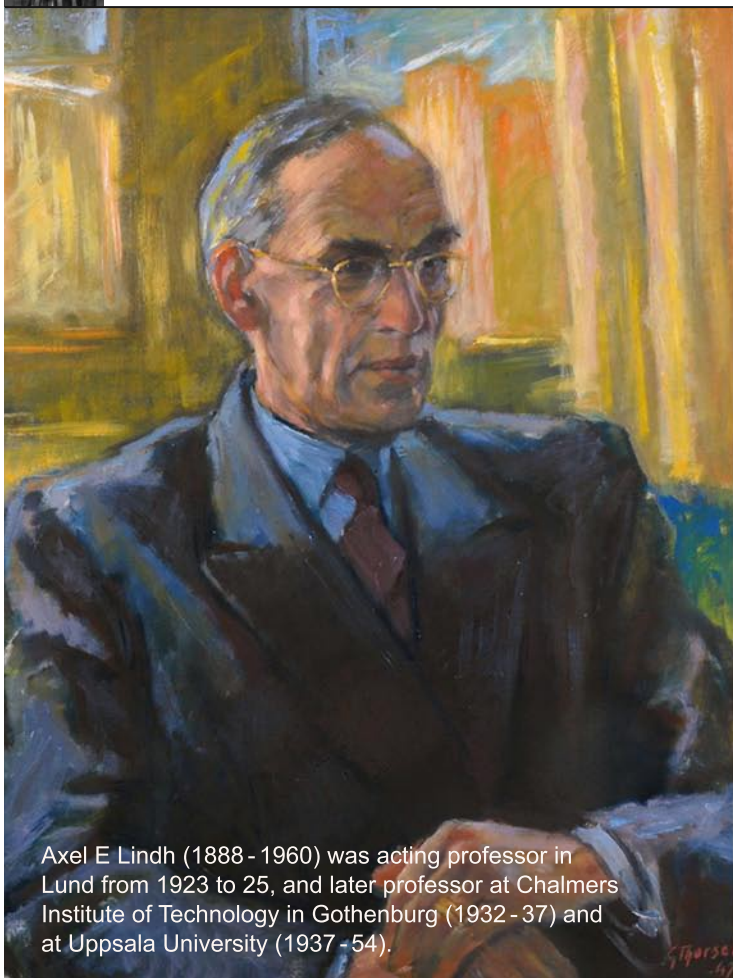

Axel E Lindh (1888 - 1960) was acting professor in Lund from 1923 to 25, and later professor at Chalmers Institute of Technology in Gothenburg (1932 - 37) and at Uppsala University (1937 - 54).

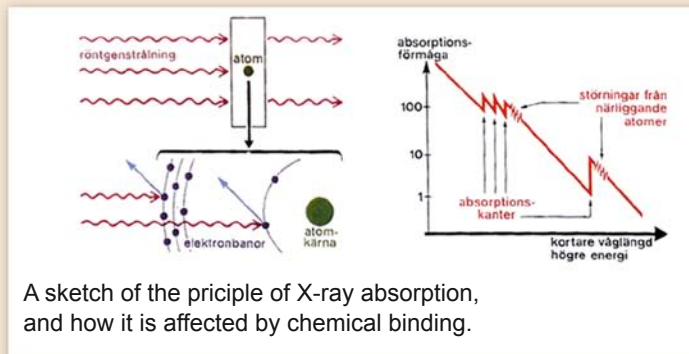

A sketch of the principle of X-ray absorption, and how it is affected by chemical binding.

Axel Lindh succeeded Borelius as a teaching assistant in 1920, after having presented his doctoral thesis on X-ray absorption by chlorine, sulphur and phosphorus. He was naturally interested in Bergengren's experiments on phosphorus, and was able to show that the position and structure of the absorption limit were dependent on the chemical binding of the atoms. This was a completely new finding, which was to be of fundamental importance in modern spectroscopy.

Many of the projects carried out at the MAX IV Laboratory today utilize this property to determine the structure of molecules.

A young talent

Torsten Heurlinger was born in Halmstad, some 130 km away, but he attended upper secondary school in Lund. It was clear early on that he had a particular talent for science and mathematics.

After obtaining his degree in physics, mathematics, mechanics and astronomy, he studied under Professor Walfrid Ekman, dedicating his time to mathematical physics. His interest was soon directed towards the band spectra of molecules whose interpretation, in contrast to the line spectra of atoms, was still shrouded in mystery.



Torsten Heurlinger 1893 - 1927



Band spectra

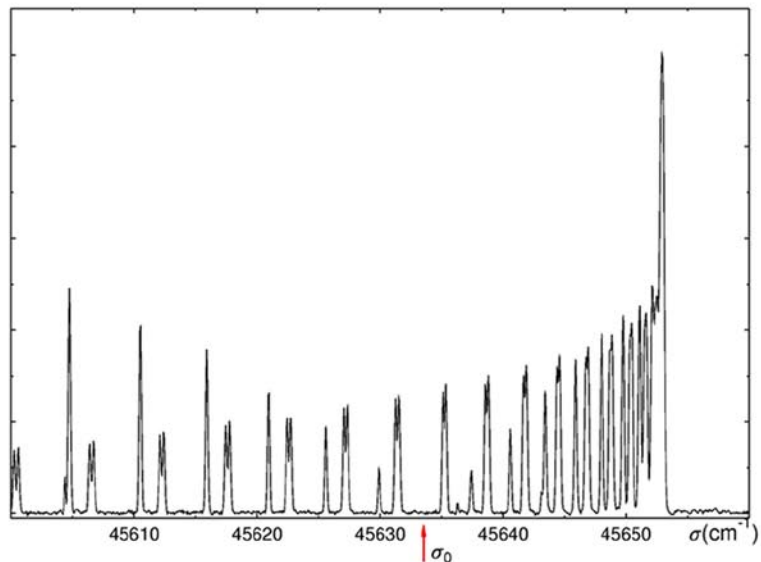

This modern spectrum has significantly better resolution than the photographic spectra analysed by Heurlinger.

Heurlinger's studies of band spectra were carried out in close collaboration with Siegbahn's research group, especially Erik Hulthén. He presented the results of these studies in his doctoral thesis, *Studies on the Structure of Band Spectra*, in 1918, aged only 25.

It had previously been assumed that the series of lines in a band started at the edge of the band, but Heurlinger showed that the series started in the complicated band structure (arrow).

A curtailed career

Heurlinger developed a theory based on the rotation and vibration of molecules, and with the aid of the principles used by Niels Bohr in his atomic model, he was able to explain how the bands were formed. Heurlinger's work forms the basis of modern molecular spectroscopy.

Unfortunately, Heurlinger did not have the opportunity to develop his theories as he was forced to give up his research in 1920 due to serious illness.

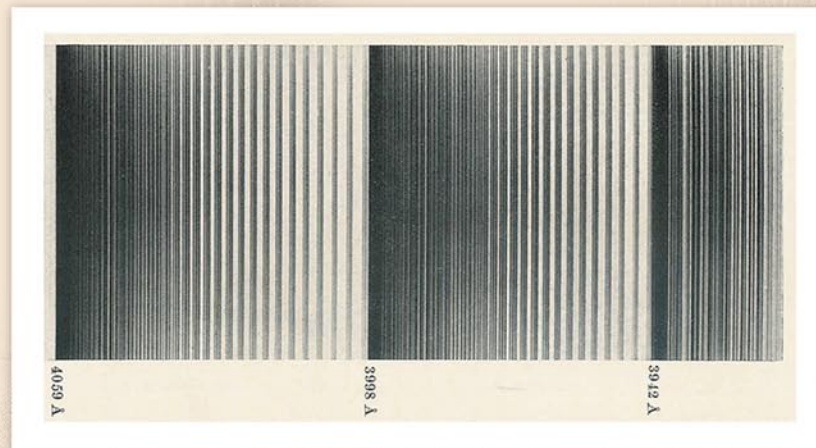

Molecular spectroscopy

Erik Hulthén had worked together with Torsten Heurlinger in the experiments on molecular spectra. When Heurlinger was forced to leave the department due to illness, Hulthén continued the work.

Hulthén obtained his doctorate in 1923, his thesis entitled *On the Combinatorial Relations of Band Spectra*. Six years later, in 1929, Hulthén was appointed Professor of Physics at what is now Stockholm University.

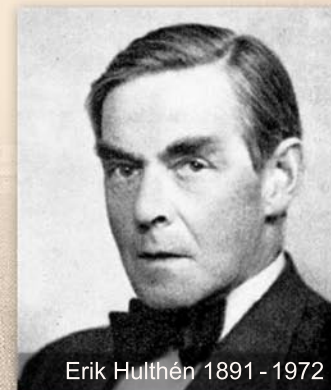

Erik Hulthén 1891 - 1972

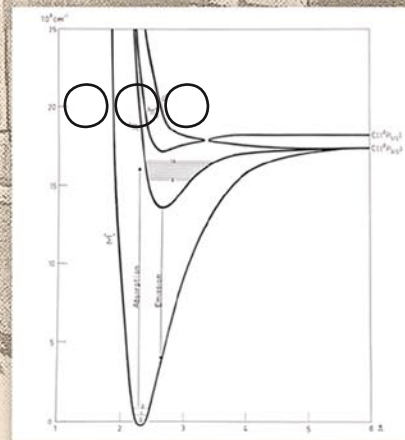

Absorption and emission of an iodine chloride molecule.

Spectroscopic instruments

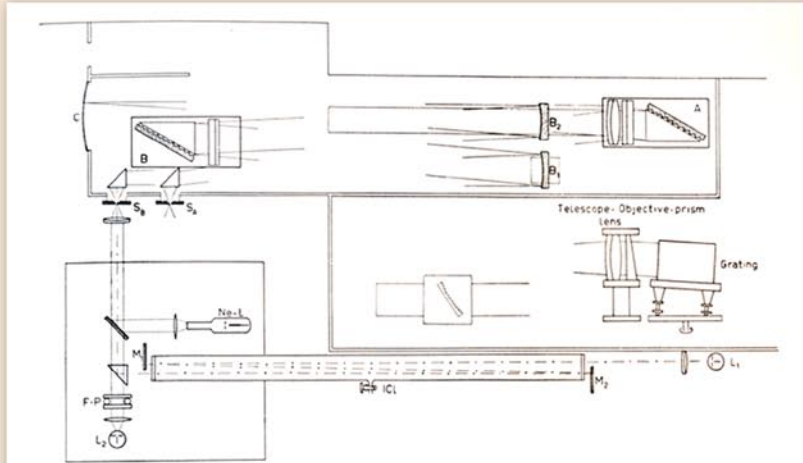

- S_A Entrance-slit for the lens equipment
- A Immersion-grating in autocollimation
- S_B Entrance-slit for the concave mirror equipment
- B Immersion-grating in the Pfund-mounting
- B_1 Collimating mirror
- B_2 Focussing mirror
- C Photographic plate holder
- L_1 Zirconium-oxide lamp
- M_1, M_2 Plane mirrors for multipole passages of light through the absorption cell *ICl*
- L_2 Sylvania lamp
- F-P Fabry-Perot etalon

As the newly appointed Professor of Physics, Hulthén lost no time in appointing a professor of mechanics. He wanted to modernize the subject of physics at the University and decided that this theoretical position should be held by someone who had carried out research in atomic theory. The choice fell on Oskar Klein, previously a student of Svante Arrhenius.

Hulthén established experimental molecular physics at Stockholm University, where he carried out extensive studies of molecular spectra, and developed optical and spectroscopic instruments.

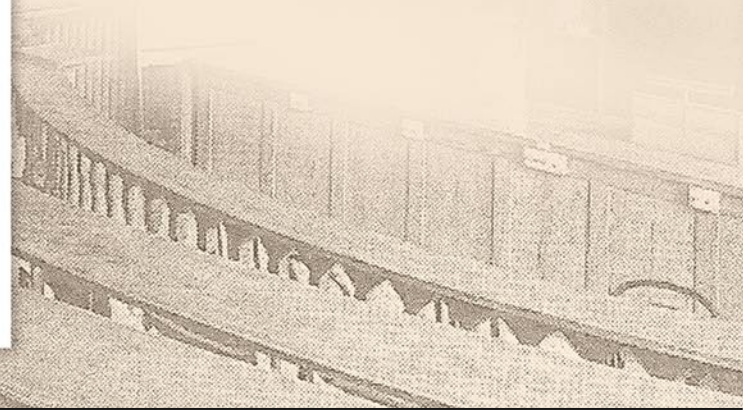

Niels Bohr's assistant

$$\frac{1}{c^2} \frac{\partial^2}{\partial t^2} \psi - \nabla^2 \psi + \frac{m^2 c^2}{\hbar^2} \psi = 0.$$

The Klein-Gordon equation

or in another system of units

$$-\partial_i^2 \psi + \nabla^2 \psi = m^2 \psi$$



Oskar Klein 1894-1977

Oskar Klein was interested in modern quantum physics already as a PhD student. At the time of the Siegbahn-Sommerfeld conference in 1919 he was Niels Bohr's assistant, and in the spring of 1923, after obtaining his doctorate, he took up a position in Lund. At this time, Klein presented Niels Bohr's theory of the atom in *Kosmos*, the yearbook of the Swedish Physical Society. By 1927, when the principle of complementarity was formulated, he had become Niels Bohr's closest collaborator.

Klein the visionary

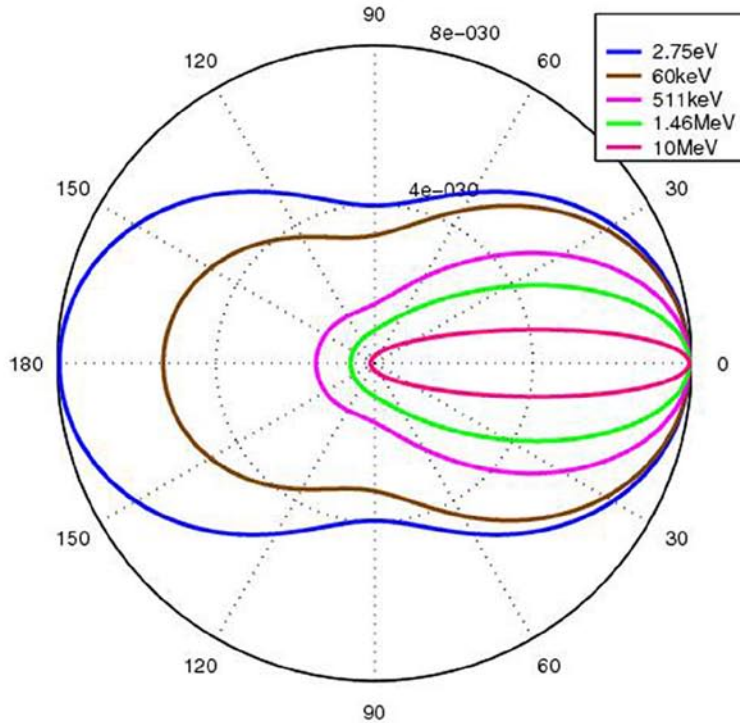

The Klein-Nishina distribution of photon scattering angle at different energies.

In 1930 Oskar Klein was appointed Professor of Physics at what is now Stockholm University, but his most famous work was carried out during his time in Lund (1923 - 1928), namely the five-dimensional unified field theory, which can be said to be a precursor to string theory, the Klein-Gordon equation, which is a further development of the Schrödinger equation including corrections for relativistic effects, the Klein-Nishina formula, and Klein's paradox.

Klein's paradox states that when electrons meet an electric potential in vacuum, the number of electrons reflected by the potential is greater than the number impinging on it when the potential exceeds a certain value.



Two friends

Two physics students
– and how their lifelong friendship
enriched both politics and physics.

An avid student

Torsten Gustafson was born in Falkenberg in 1904. After graduating from school in Gothenburg at the age of 18 he started studying at Lund University. He was a dedicated student and obtained his bachelor's degree after only 1½ years, and his master's after a further year's study.

During this period, he shared living quarters with another science student, a certain Tage Erlander from Värmland.



Torsten Gustafson 1904 - 1987



A well-known student of physics

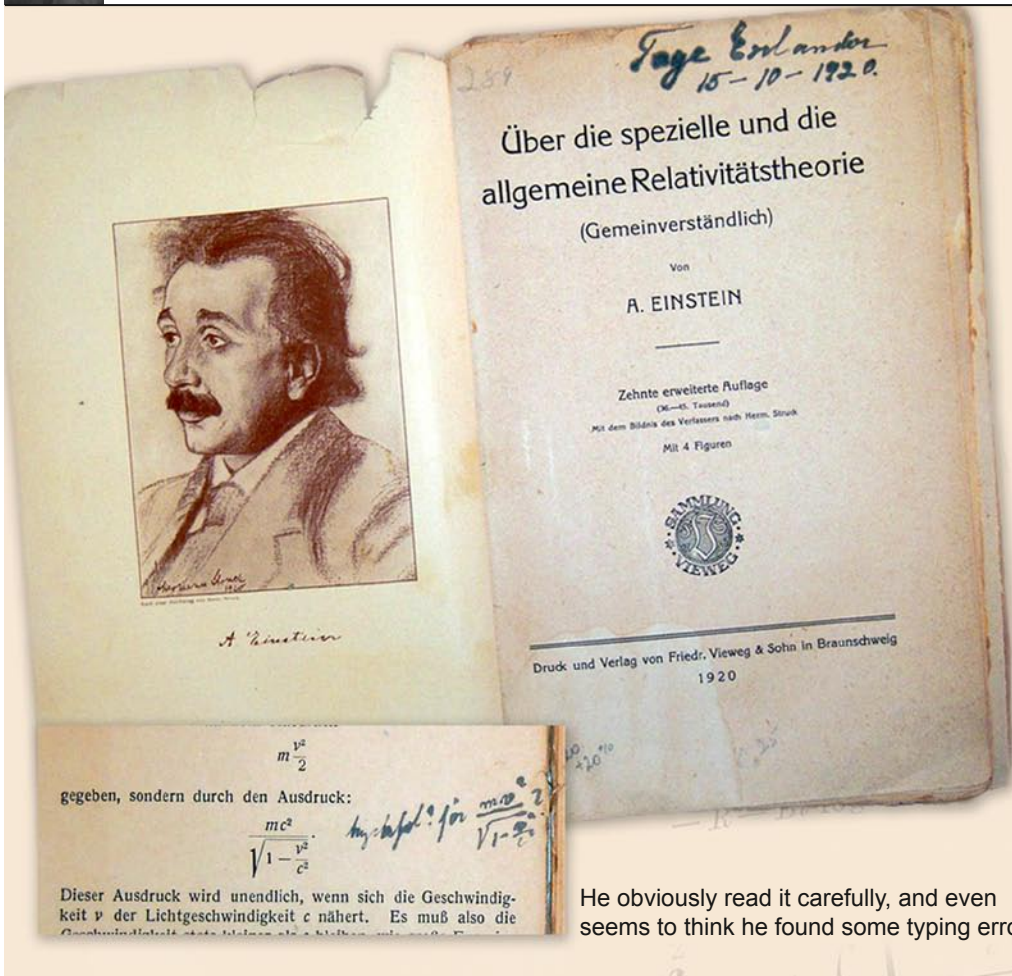

The most well-known to date, if not the most successful, student at the Department of Physics in Lund is Tage Erlander, later to become Sweden's prime minister. He came to Lund at the age of 19 after graduating from school in Karlstad.

During his very first term, he bought a book by Einstein describing the theory of relativity in popular scientific terms. In the autumn of 1920 he took part in laboratory exercises, and attended Manne Siegbahn's lectures in general physics.

He obviously read it carefully, and even seems to think he found some typing errors.

Young scientists

In 1923 Tage Erlander and two fellow students founded the Mathematical Society. Tage was its first chairman, and the members included Torsten Gustafson and Aina Andersson, later to become Tage's wife.

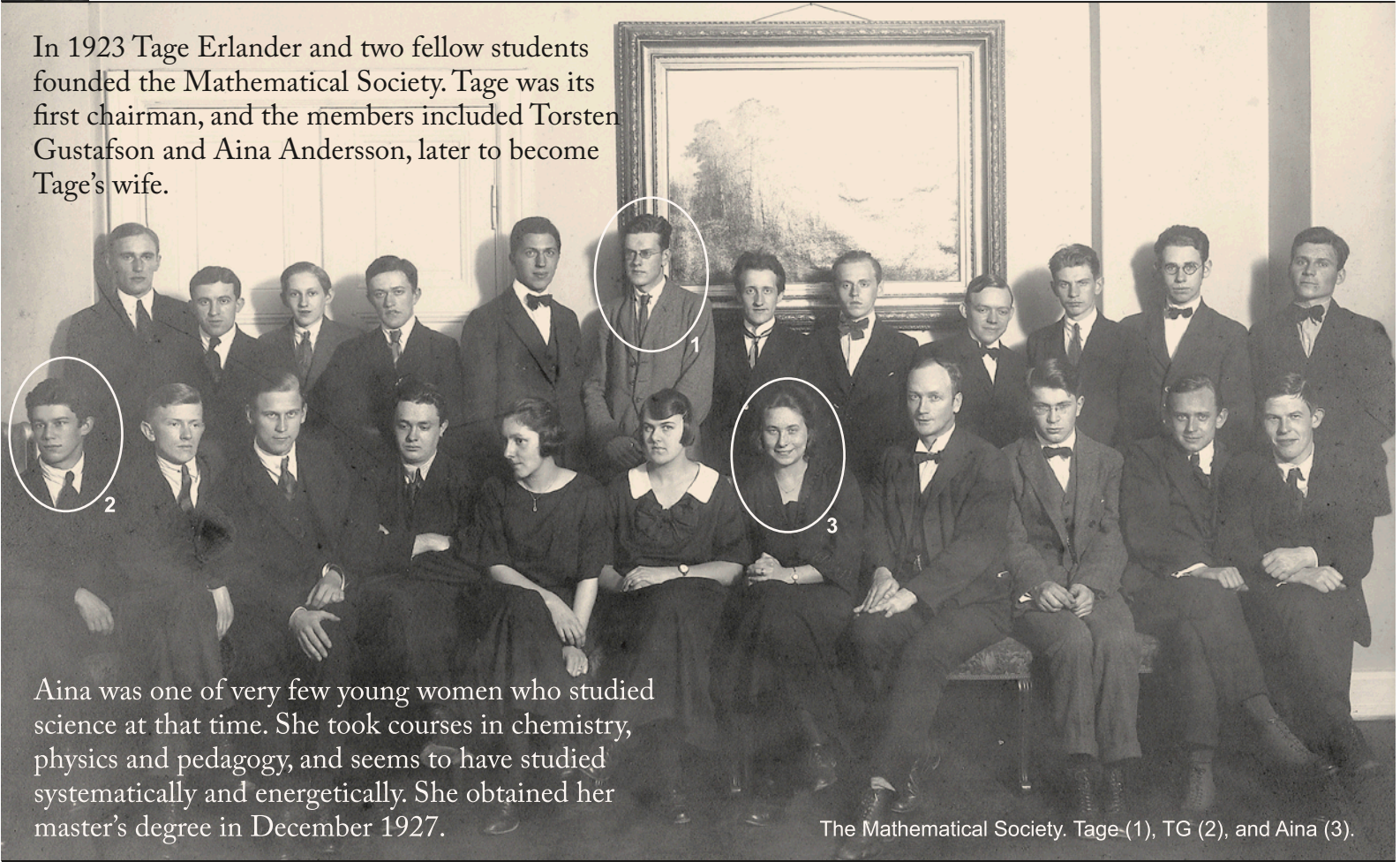

Aina was one of very few young women who studied science at that time. She took courses in chemistry, physics and pedagogy, and seems to have studied systematically and energetically. She obtained her master's degree in December 1927.

The Mathematical Society. Tage (1), TG (2), and Aina (3).

Radical students

During the spring of 1925, Tage and Aina attended lectures in physics, although Tage had started to take a greater interest in politics. There were many among the science students who had radical political opinions, and Tage Erlander was transformed, from the liberalism of his parents' home, to radical socialism.

He and Torsten both joined the radical student societies Clarté and DYG, *De Yngre Gubbarna* (*The Younger Old Men*). Tage even became a member of the Lund branch of the Swedish Social Democratic Party, where he came into contact with leading Swedish social democrats.

Tage's and Aina's names at the top of a list of applicants for a course in heat and electricity.

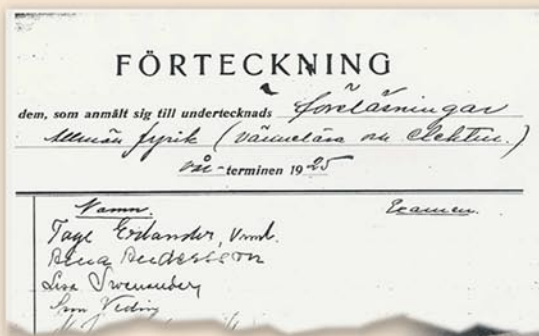

The Mathematical Society on a day trip. In the foreground are Aina and Tage, and Torsten Gustafson in a white student's cap.

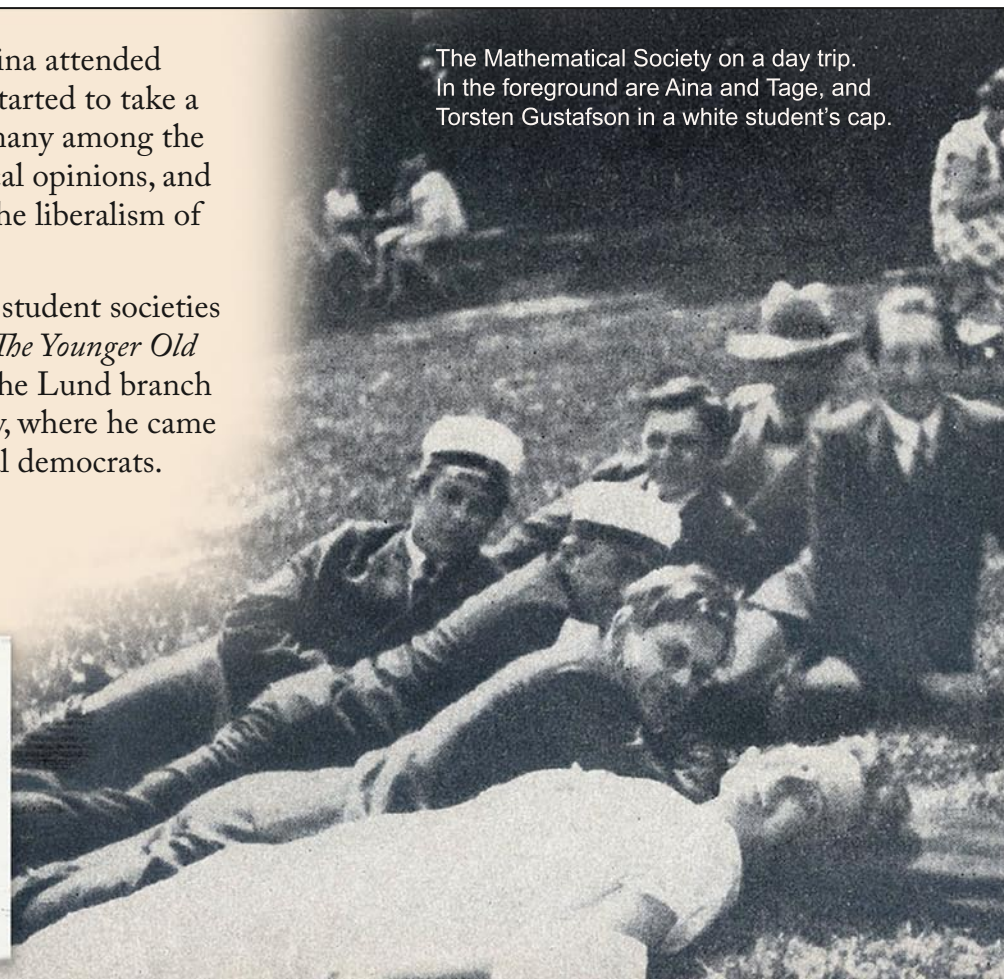

Postgraduate students

After graduating, Torsten Gustafson had intended to continue his studies in atomic physics. However, a mathematical problem associated with the aerodynamics of aeroplane wings, and later hydrodynamics, kept him busy for the next few years. In 1933 Torsten Gustafson presented his thesis: *On the Magnus Effect on the Asymptotic Theory of Hydrodynamics*.

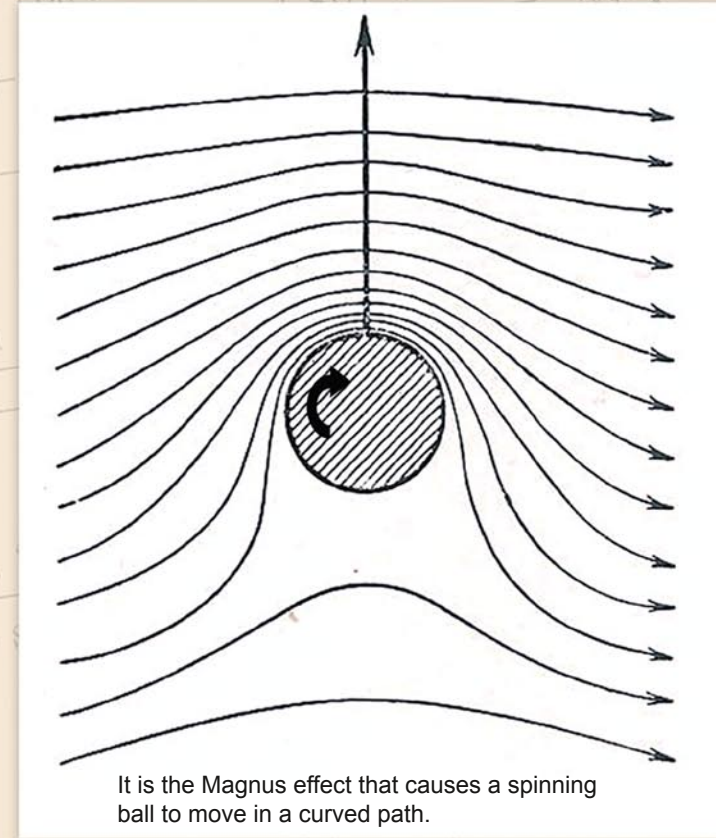



Change of plans

In contrast to his fellow student Torsten, Tage Erlander never completed his scientific studies, but changed direction to a subject more in line with his political interests.

In 1927 he completed a course in political science, and during the spring and summer of 1928 took courses in economics and statistics. Enthused by his new area of study, Tage proved to be as avid a student as his friend Torsten, and graduated in September 1928.

He and Aina were married in 1930.



An academic career

In 1935 Torsten Gustafson returned to his original plans, and started work in the field of quantum mechanics, mainly problems in quantum electrodynamics.

He was in close contact with Niels Bohr in Copenhagen from 1936, and he made many friends among leading atomic physicists of the time through his work at the Niels Bohr Institute.

In 1939 Torsten Gustafson became Professor of Mechanics and Mathematical Physics in Lund. In 1961 he became Professor of Theoretical Physics.

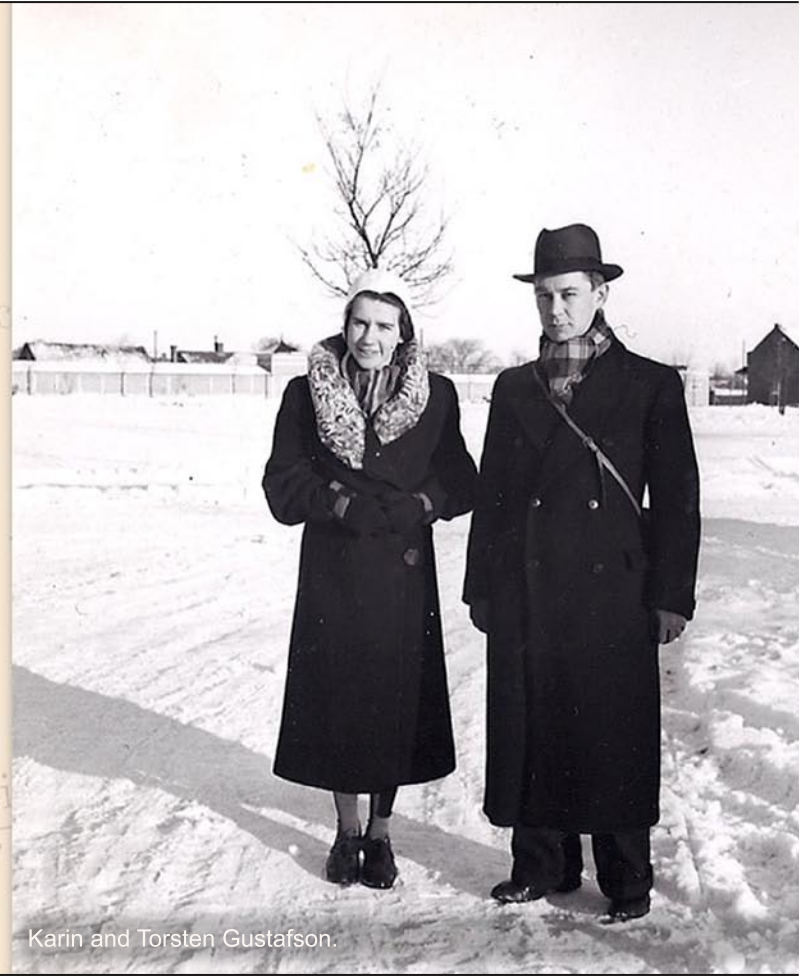

Karin and Torsten Gustafson.

$$\frac{i}{2\pi} \int_{\frac{\pi}{2}}^{\frac{3\pi}{2}} d\tau(\theta') \left[\int_{-R}^R \frac{\cos \theta'}{\varphi + i \sin \theta' - e^{i\theta}} d\varphi - \frac{1}{-R - Bi \log R} \right]$$

$$-\frac{i}{2\pi} \cdot B \int_{-R}^R d\tau(\theta') \int_{\frac{\pi}{2}}^{\frac{3\pi}{2}} \left[\frac{i(\varphi - i \sin \theta')}{(\varphi + i \sin \theta' - e^{i\theta})} \right]$$

Established careers



By the time the Second World War broke out in 1939, both Torsten and Tage had influential positions, one as a professor and the other as an undersecretary of state. The war naturally had considerable effects on both of them, as it did on everyone in Sweden, and especially those in other countries.

The friendship between Tage and Torsten continued, and Tage often received advice and information from Torsten who was well-informed thanks to his extensive international network.

From the first time I met Torsten Gustafson, who was later to become a professor, we had long discussions on everything between heaven and earth.

A deep friendship developed between us, which has continued throughout the years.

From Tage Erlander's memoirs

A political career

Tage Erlander advanced rapidly in the Social Democratic party. He became a member of parliament in 1932, and six years later the Erlanders moved from Lund to Stockholm. In 1939 he was appointed undersecretary of state in the Ministry of Health and Social Affairs, and in 1945 he became Minister of Education and Ecclesiastical Affairs, and was responsible for higher education and research. The spheres of the two friends were thus brought closer together.

In October 1946 the prime minister of the day, Per Albin Hansson, passed away, and Tage Erlander was elected to the position of party chairman. The former physics student from Lund had become his country's prime minister.



Tage Erlander, 1901 - 1985
Swedish Prime Minister between 1946 - 1969.



A Reflection of Our Time



At the beginning of the Second World War, Lund University had the reputation of being more pro-Nazi than other Swedish universities. However, in 1942 ten professors from Lund University published a book entitled *A Reflection of Our Time*, emphasizing that there was also a strong anti-Nazi opinion at the University. Torsten Gustafson was the first of the authors, and described, amongst other things, nuclear fission, first accomplished in 1939, which could provide a huge source of energy, but could also be used to make a bomb – scientists must investigate the laws of nature, but can not be blamed for the misuse others make of the discoveries.

The scientific community is a true democracy, where there is no racial infamy. Persecution is found in dictatorships, not in democracies. It is distorted doctrines that threaten civilisation.

From Torsten Gustafson's article in the book, *A Reflection of Our Time*.

The revitalization of science

During the war, in August 1944, the Swedish Government appointed a committee to study mathematical and scientific research. Among the members of this committee were Manne Siegbahn and Bengt Edlén. The committee proposed a substantial expansion and development of scientific research, and parliament adopted a bill leading to 17 new professors and assistant professors.

In his memoirs, Tage Erlander thanks those who helped him with the bill, among them Torsten Gustafson.

Although it was fun, my strongest feeling was nevertheless happiness that my failures in the field of science in Lund had given me a chance no other politician had had.



To coalition government with Erlander as minister without portfolio.

Atomic power



After the atomic bombs had been dropped on Hiroshima and Nagasaki in August 1945, nuclear physics became known to the whole world. Torsten had constantly updated Tage on developments within the field. He also passed on the belief of Niels Bohr that it would be possible to develop nuclear power in a trusting collaboration.

Erlander wasted no time, and in 1945 he appointed a committee to organise research into nuclear power, and to plan the construction of nuclear reactors. Torsten Gustafson was a member of this committee.

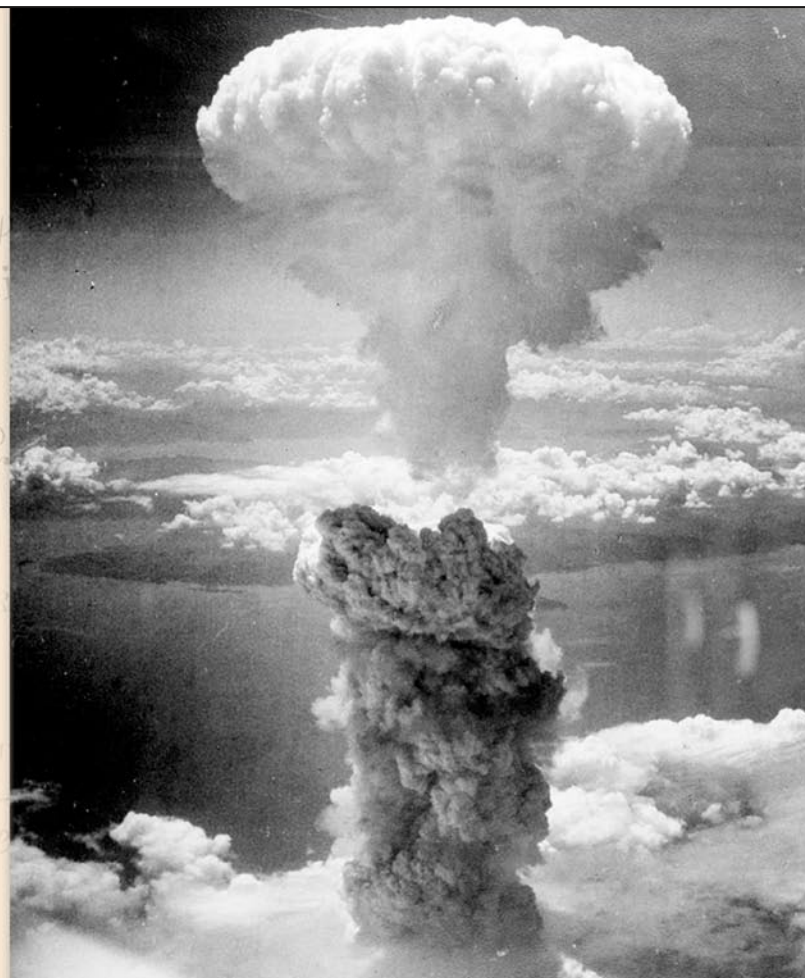

A Swedish atomic bomb?



In discussions on the use of nuclear energy, the question arose as to whether Sweden should develop nuclear weapons. The extensive resources of uranium in the country, and the planned heavy-water reactor would allow sufficient amounts of plutonium to be made. However, strong voices were raised against Swedish nuclear weapons, not least by the women of the Social Democratic party. Erlander tried to unite the party, and appointed a working party including representatives of all opinions. They issued the following statement in December 1959:

At the present time, overriding reasons speak against the development of atomic weapons.

The A32 Lansen attack aircraft was a possible weapon carrier for aerial atomic bombs.

European cooperation

The joint European research establishment, CERN (Conseil Européen pour la Recherche Nucleaire) was established in Geneva in Switzerland in 1953 to balance the strong scientific dominance of the USA and to prevent a brain drain from Europe to North America.

Torsten Gustafson was one of the Swedish delegates for the first ten years of its existence, and was very positive about the work carried out there. According to Gustafson, the harmonious collaboration between the 12 member nations was a good example that could be followed by others.

CERN's current 20 member states.
The countries shown in blue were the founding nations in 1954.

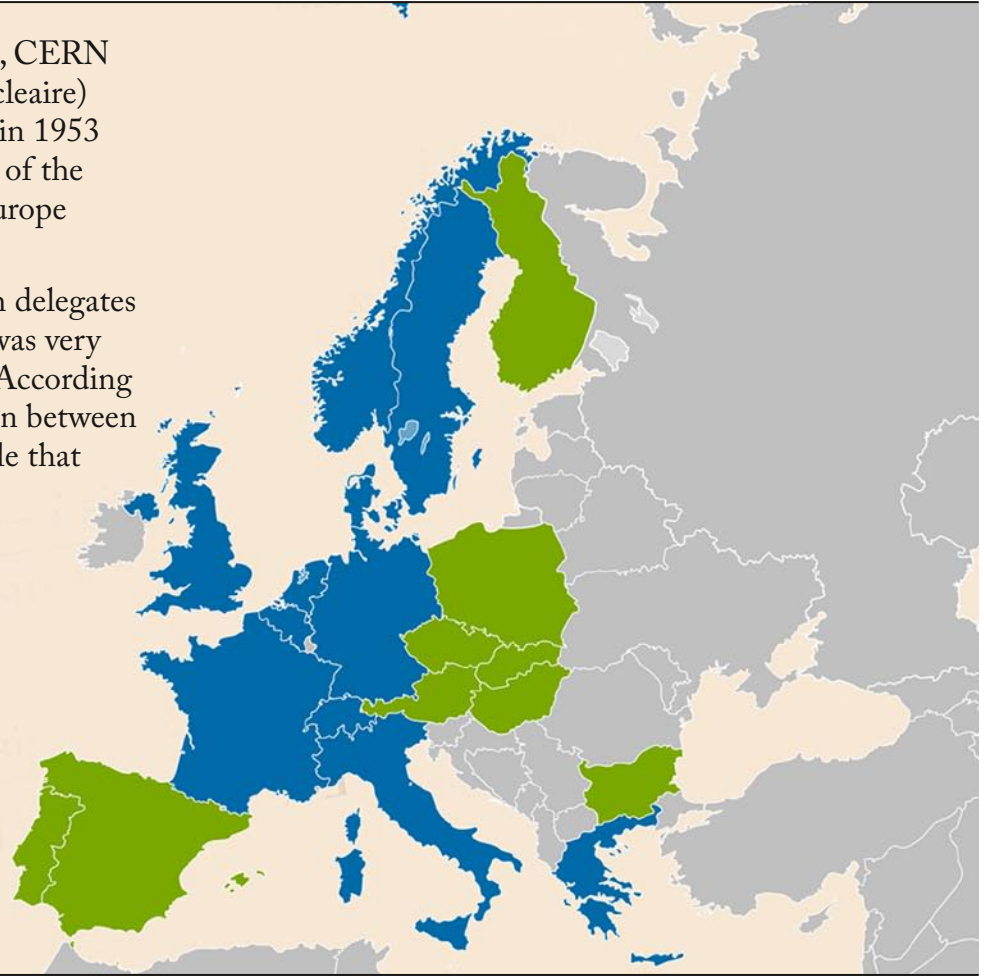

Nordic cooperation

Niels Bohr had previously suggested that a large inter-Nordic research institute be established in Lund. NORDITA, The Nordic Institute for Theoretical Atomic Physics, was established in Copenhagen in 1957, the chairman for the first five years being Niels Bohr. Torsten Gustafson was vice-chairman during the same period. When Bohr died, Gustafson took over as chairman and held the position until 1969.

Theoretical physics flourished in Lund, thanks to Gustafson's ability to gather gifted doctoral students, such as Sven Gösta Nilsson, Gunnar Källén and Hellmuth Hertz, around him.



NORDITA in Copenhagen.

$$-\frac{i}{2\pi} \cdot B \int_{-\frac{\pi}{2}}^{\frac{\pi}{2}} d\tau(\theta') \int_{-R}^R \left[\frac{i(\varphi - i \sin \theta') - 2 \sin \theta'}{(\varphi + i \sin \theta' - e^{i\theta})(\varphi^2 + \sin^2 \theta')} - \frac{i(\varphi^2 + \sin^2 \theta') + (\varphi - i \sin \theta') \cdot 2 \sin \theta'}{11(\varphi^2 + \sin^2 \theta')} \right] \cdot d\varphi +$$

Old friendship

The friendship between Torsten Gustafson and Tage Erlander lasted their whole lives. Erlander's deep faith in Torsten Gustafson can be clearly seen in several places in his diaries and his memoirs.

Torsten Gustafson is typical of physicists who, more than any other group, have contributed to the rapid technical development of our society.



Karin and Torsten Gustafson chatting with Aina and Tage Erlander.



The corona mystery

About the man who solved the corona mystery and at the same time proved that the temperature, just above the surface of the sun, is 2 million degrees instead of 6 000 that had previously been assumed.

Bengt Edlén, atomic spectroscopist



Bengt Edlén was born in Gusum in the county of Östergötland, Sweden, in 1906. After leaving school in Norrköping he began studying at Uppsala University in 1927.

He obtained a Bachelor's degree after just three semesters and began research studies under Manne Siegbahn, the X-ray spectroscopist and Nobel Prize winner from Lund.

His research assignment comprised studies of spectra in short-wave ultraviolet light from highly ionised atoms, atoms that had lost a large number of electrons.



Bengt Edlén was the eldest of five siblings.

The Sun's corona



During a solar eclipse, when the face of the Sun is hidden, the corona remains visible – a shining area around the edge of the Sun.





Coronium, an unknown chemical element?

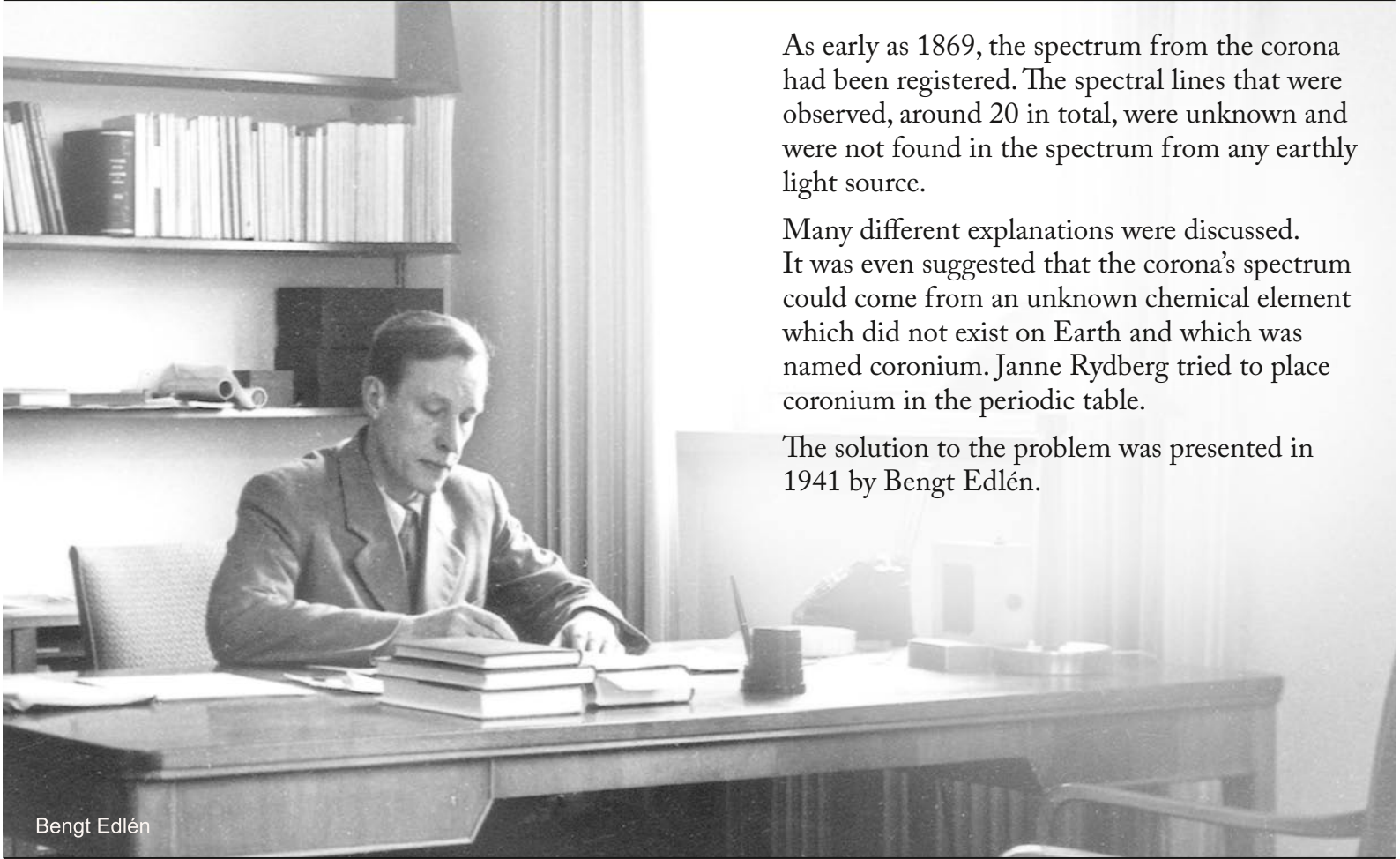

Bengt Edlén

As early as 1869, the spectrum from the corona had been registered. The spectral lines that were observed, around 20 in total, were unknown and were not found in the spectrum from any earthly light source.

Many different explanations were discussed. It was even suggested that the corona's spectrum could come from an unknown chemical element which did not exist on Earth and which was named coronium. Janne Rydberg tried to place coronium in the periodic table.

The solution to the problem was presented in 1941 by Bengt Edlén.

Atomic spectroscopy

In an atom which is excited, given a surplus of energy, one or more electrons enter a higher energy state. When an electron then returns to a lower energy state, the energy is radiated as light at fixed wavelengths. By measuring the wavelengths of these spectral lines it is possible to determine the various energy states, the atom's energy structure.

Bengt Edlén used spark discharges of 80 000 volts to ionise and excite the atoms. The spectrum was registered photographically in a spectrograph, specially constructed for ultraviolet light.

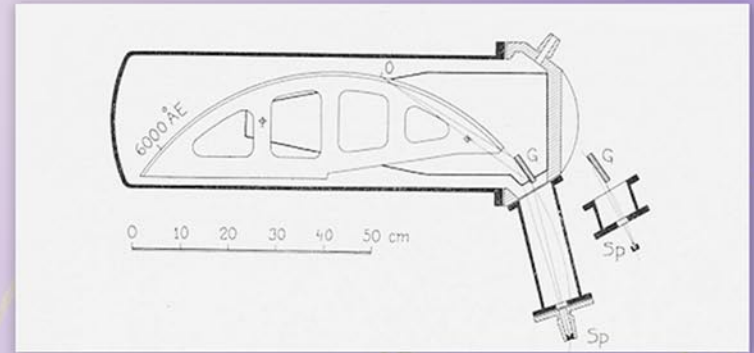

Doctoral thesis

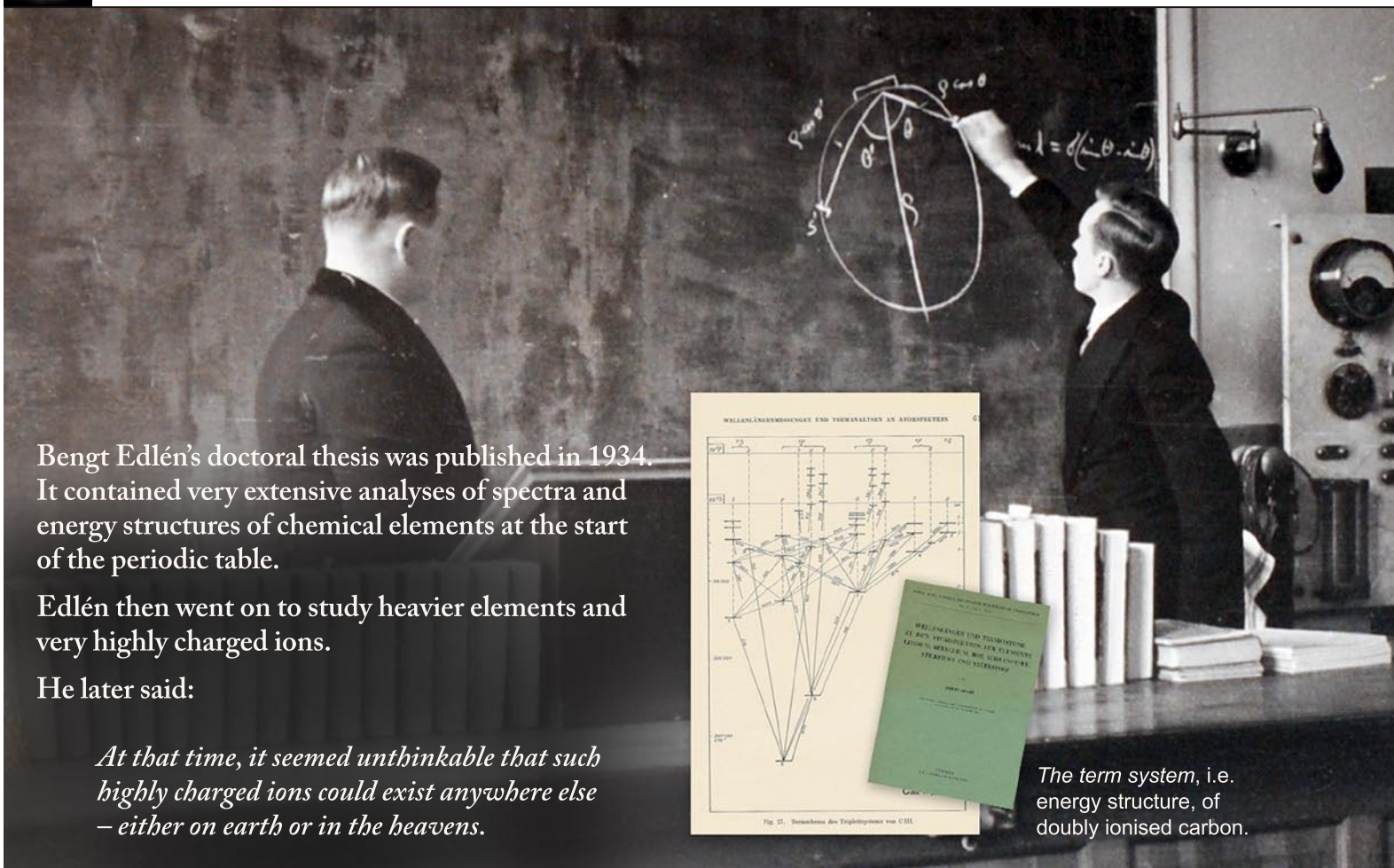

Bengt Edlén's doctoral thesis was published in 1934. It contained very extensive analyses of spectra and energy structures of chemical elements at the start of the periodic table.

Edlén then went on to study heavier elements and very highly charged ions.

He later said:

At that time, it seemed unthinkable that such highly charged ions could exist anywhere else – either on earth or in the heavens.

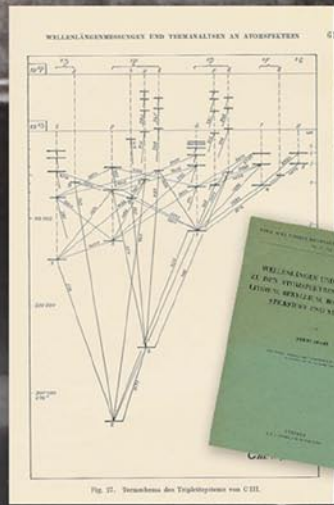

The term system, i.e. energy structure, of doubly ionised carbon.

The answer to the corona mystery

With the help of his new measurements and analyses, in 1941 Bengt Edlén was able to show that the unknown lines in the corona's spectrum were forbidden lines from very highly charged ions of calcium, iron and nickel.

These forbidden lines can only occur in matter with very low density where the atoms are rarely subject to collisions. This is why they could not be observed in the laboratory.

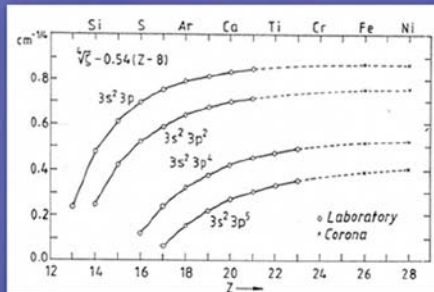

Edlén was able to identify some of the 20 corona lines directly from his new analyses of the structure of atoms, while in other cases he based his work on careful extrapolations.

The Sun in a new light

The temperature on the surface of the Sun is around 6 000 degrees centigrade. It had previously been presumed that the temperature around the Sun was much lower than on the surface. Edlén's results showed rather that the temperature in the corona must be around 2 000 000 degrees centigrade. The view of the Sun's structure had to be revised.

The interpretation of the corona lines was naturally published in scientific journals and drew a lot of attention. Bengt Edlén became famous even in the daily press.

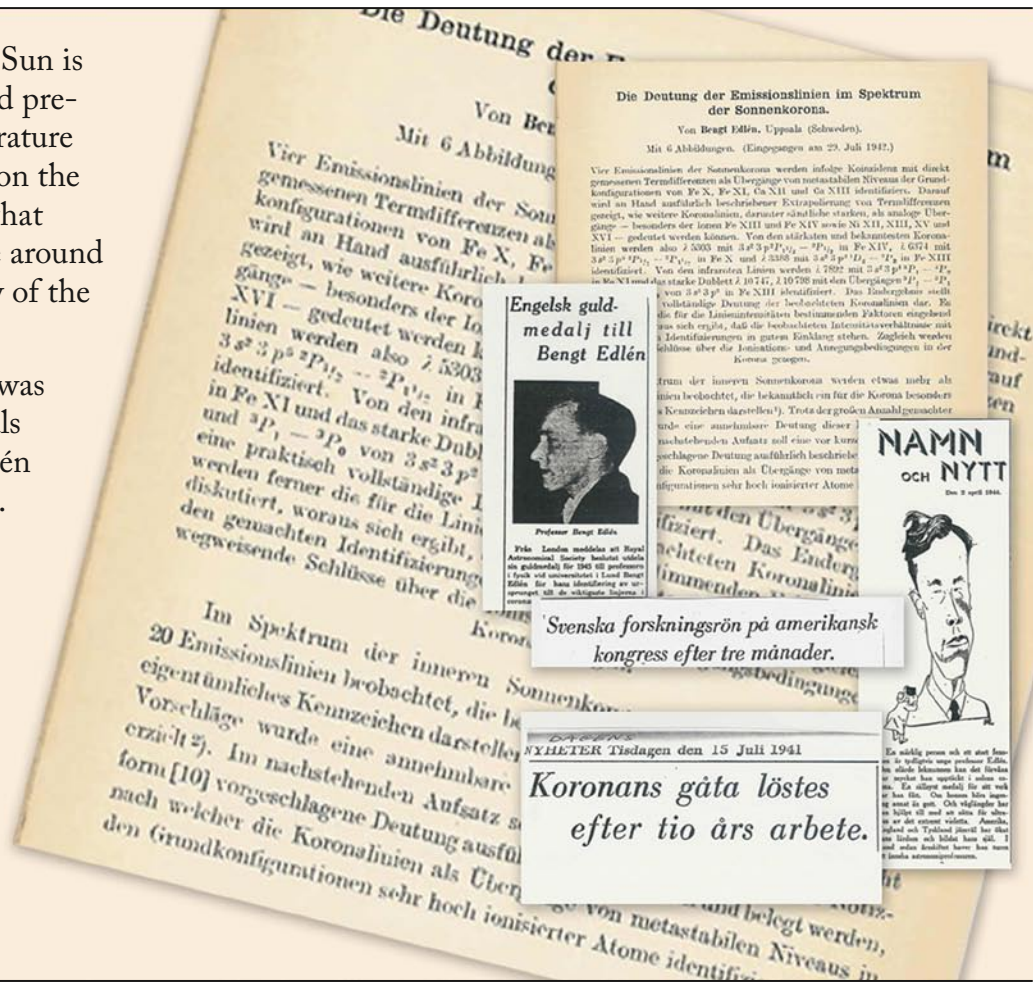

Calculations and analyses

Edlén's early work was carried out before the age of computers. An important aid in his analyses was diagrams, on which the scale and units were chosen so that any errors or anomalies would be easily exposed.

He made his calculations with the help of a mechanical Odhner calculator.

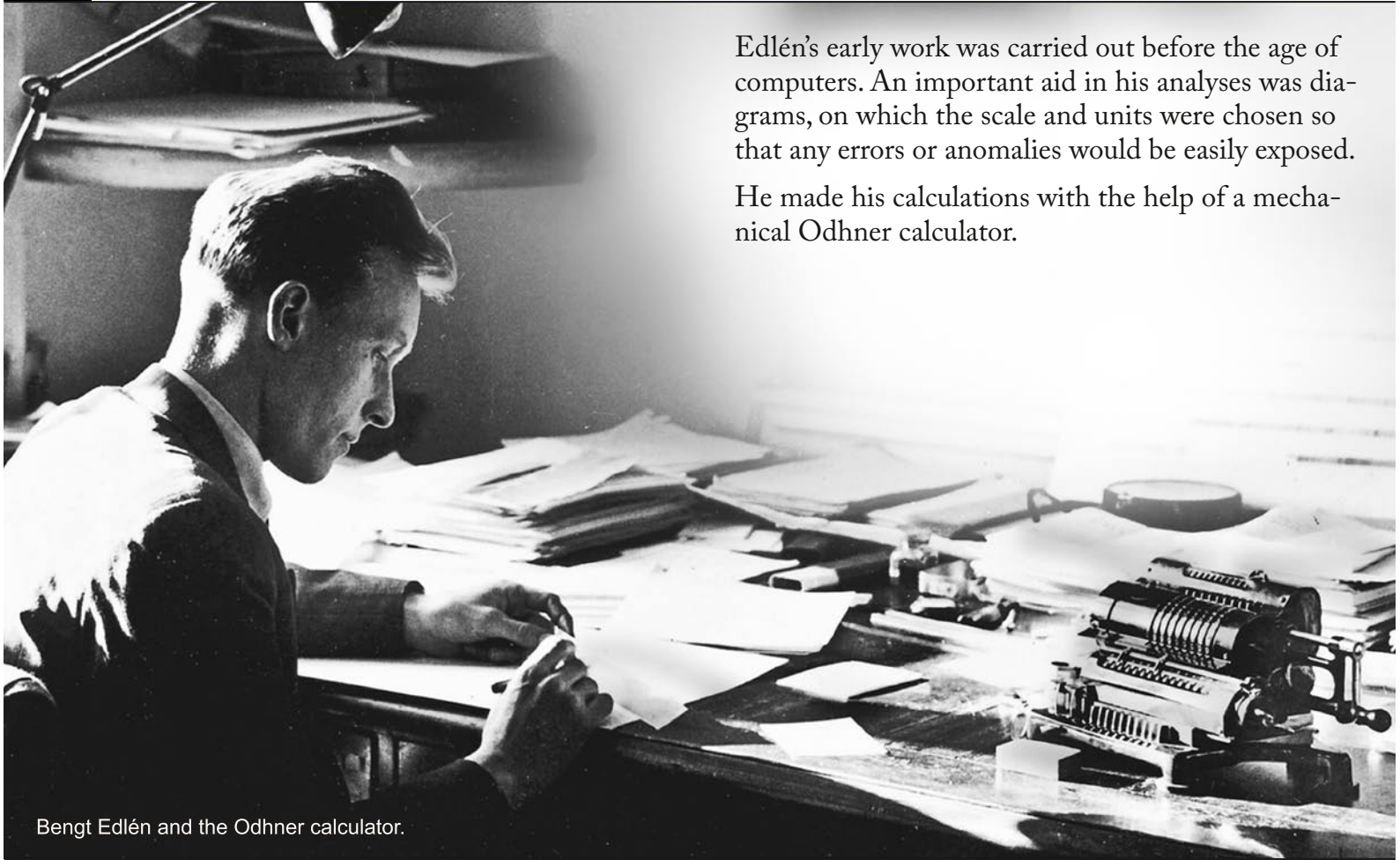

Bengt Edlén and the Odhner calculator.





To Lund

In 1943 Bengt Edlén was appointed Professor of Physics at Lund University. At the time there was only one Chair in Physics here. Previous holders included Rydberg and Siegbahn.

One of Edlén's first tasks was to lead the planning of a new building for the department.



The new building was inaugurated on 31 May 1951 by King Gustaf VI Adolf of Sweden.



Atomic spectroscopy in Lund



Bengt Isberg



Lennart Johansson



Lennart Johansson and Sonja Mickelson.



Ulf Litzén

Spectroscopy research had been conducted in Lund since Rydberg's and Siegbahn's time. Edlén could now build on that work and his research group expanded the studies to include increasingly complicated atoms.

New spectrographs and light sources for different types of atom and ionisation stages were constructed.

Edlén was now well known in the research community. He was engaged as a spectroscopy expert by the International Astronomical Union, among others, and on the international committee which drew up the new metre definition.

Atoms and stars

Bengt Edlén had an early interest in astronomy. He began to study a special type of very hot stars in 1931. He said:

I view these so-called Wolf-Rayet stars as my special friends, since they were the source of my first contribution to astrophysics.

He continued with this work in Lund, and thanks to new laboratory studies, in 1956 he was able to explain almost all the details of these stars' spectra.

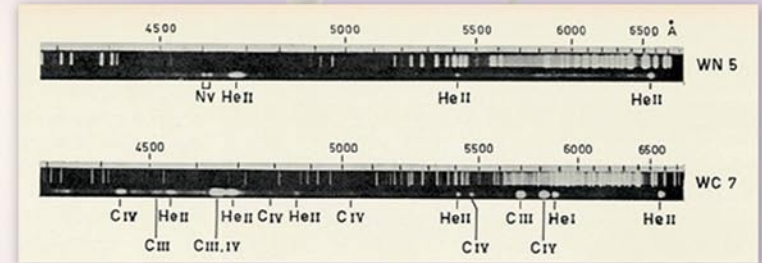

By comparing the spectral lines in the light from a star with laboratory spectra, it is possible to tell which chemical elements the star contains.

With sufficient knowledge of the atomic structure, the lines can be used to determine how much of each element there is in the star and the star's temperature.

Space spectra

Edlén's research became highly topical when the space research programmes began. As early as 1946, a rocket was sent up from the USA with a spectrograph for the first observations of the Sun's ultra-violet spectrum.

The higher up in the atmosphere one came, the more of the Sun's UV spectrum could be seen. Many of the spectral lines could be identified thanks to Edlén's early observations in the laboratory.

New laboratory data was needed and the activities of the spectroscopy group in Lund expanded substantially.

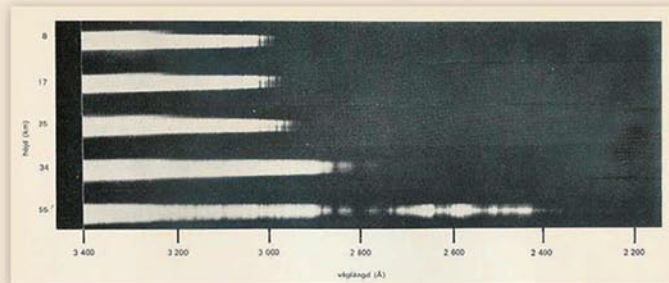

Solar spectrum observed at increasing height with the first rocket-borne spectrograph. In the bottom spectrogram the rocket has passed through the ozone layer 50 km above the earth's surface, and for the first time one can see a part of the Sun's ultraviolet spectrum.



Fusion research

After Bengt Edlén retired in 1973, his early research became relevant once again.

In the large tokamaks, where energy was generated through fusion, temperatures of tens of millions of degrees were reached. Density was low and the plasma resembled the solar corona.

Forbidden lines of the same type as Edlén's corona lines could be observed. The lines turned out to be the best aid for measuring the temperature and density of the plasma.

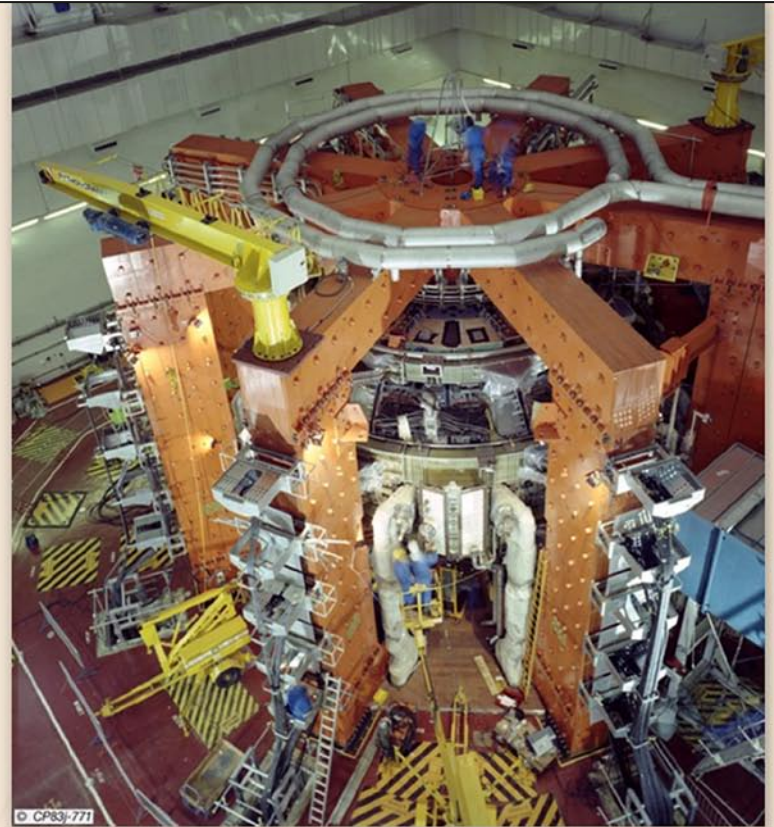

The JET tokamak at Culham, UK.

New project

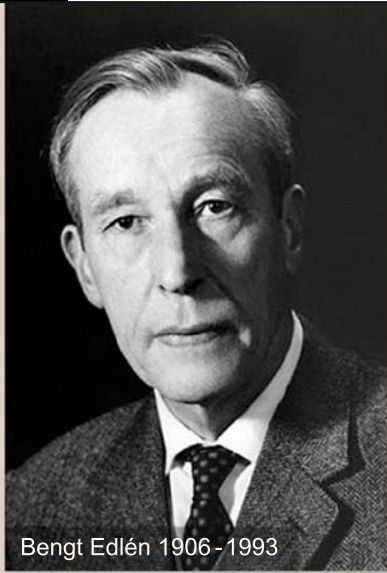

Bengt Edlén then started a new project in which he combined new observations with calculations by physicists in the USA and Russia and was thus able to predict all the relevant forbidden lines in a large number of ions. The results were published in a series of articles, concluding in 1985.

The research on the structure of atoms and ions was continued by Edlén's successor Indrek Martinson, who expanded the work to include measurements of the lifetimes of the atomic states.

The astrophysics research was also continued by a group led by Sveneric Johansson.

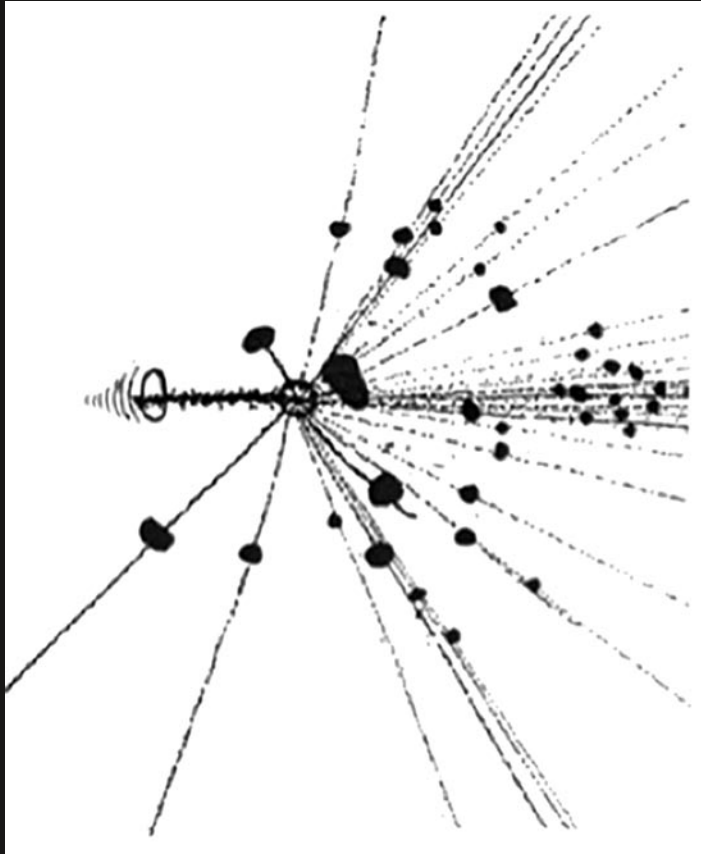

Cosmic radiation and heavy-ion physics

How scientists in Lund determined the properties of the strange K mesons, and then recreated the physical processes taking place a few millionths of a second after the Big Bang.



The discovery of cosmic radiation

In 1912, the Austrian Victor Francis Hess ascended to an altitude of 5 000 m in a hot air balloon, where he measured ionizing radiation in the atmosphere.

He found that this was three times higher than on the surface of the earth. He had discovered cosmic radiation. So what kind of radiation was this? Charged particles or electromagnetic radiation?

As the cosmic radiation is affected by the earth's magnetic field, it must consist of charged particles. Experiments showed that these particles had a high kinetic energy.



A smiling Victor Hess preparing for his ascent in 1912 to measure ionization at high altitudes using two newly developed electrometers.



Track detectors



Cecil Frank Powell (1903 - 1969) was awarded the Nobel Prize in 1950 for the development of photographic emulsions for the detection of subatomic particles.

The cloud chamber had been developed by C T R Wilson in Cambridge in the 1910s. Ionizing particles travelling through a saturated vapour cause condensation along their path, leading to visible tracks.

In the late 1930s, the British physicist Cecil Powell, working in Bristol, developed highly sensitive photographic emulsions for the measurement of high-energy ionizing particles.

Studies of K mesons

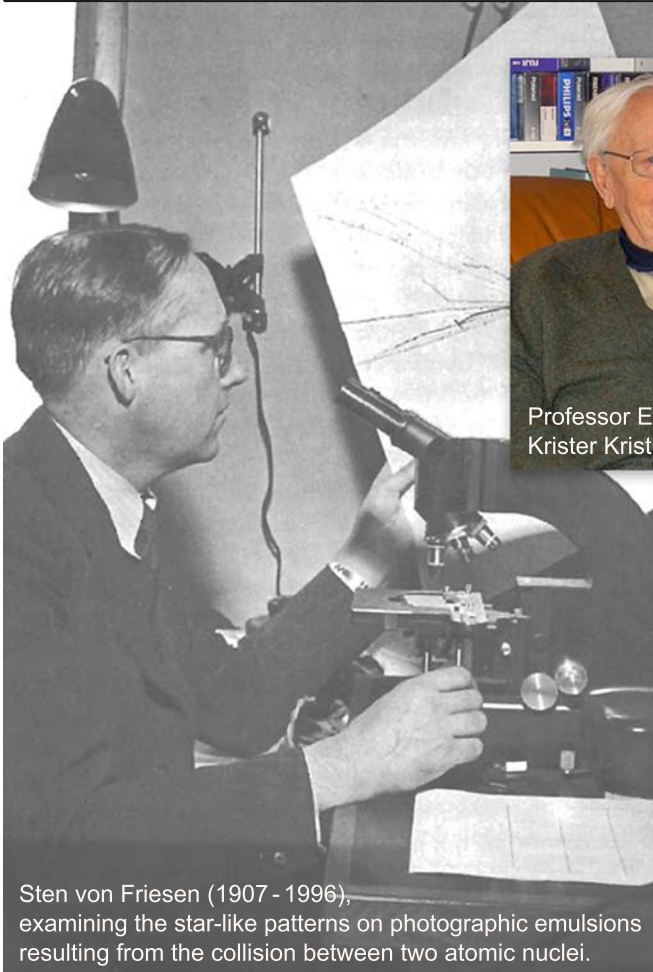

Sten von Friesen (1907 - 1996), examining the star-like patterns on photographic emulsions resulting from the collision between two atomic nuclei.

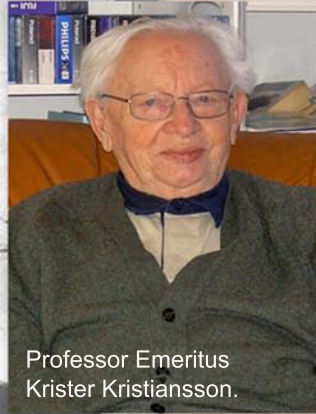

Professor Emeritus
Krister Kristiansson.

Towards the end of the Second World War, high sensitivity had been achieved in the nuclear emulsion technique, and many fundamental discoveries were made when stacks of emulsions were exposed to cosmic radiation at high altitudes.

Professor of Nuclear Physics Sten von Friesen and his close collaborator Krister Kristiansson in Lund were inspired by the results obtained by the group in Bristol and they started measurements on cosmic radiation using a Wilson cloud chamber, but quickly switched to nuclear emulsions, as these were better suited for the determination of the mass of the incoming particles.

I (Kristiansson) discussed the idea of using photometric techniques for track analysis with Sten von Friesen, and drew a sketch of the new equipment. The sketch went to Uno Persson in the mechanical workshop, where the equipment was quickly made. It worked perfectly, and I was able to analyse the tracks made by various particles.



Birgit Lindkvist



Birgit Lindkvist was awarded an honorary doctorate in 1977 for her work on developing the emulsion technique, as well as the development of a method of measuring the height of birds in flight.

Birgit Lindkvist was a research engineer at the Department of Physics in Lund who developed the emulsion technique. She became internationally recognised for her work. When analysing emulsions the grain density is measured in relation to the end point of the track. Krister Kristiansson improved these measurements using a photometric technique.



The mass of the kaon

The group in Lund was especially interested in studying the mass of K mesons, or kaons. Large balloons were used to make photometric measurements of six kaon tracks at heights of 25 - 30 km. In 1956 they determined the average kaon mass to be 974 times the mass of an electron. The spread in the measurements was small, and the systematic errors negligible. It was necessary to use short exposure times as the tracks in the emulsions faded with time.

Mesons are unstable subatomic particles. They consist of a quark and an antiquark, and may be uncharged or positively or negatively charged. The mass of the uncharged kaon is today known to be 973.8 times the mass of the electron.

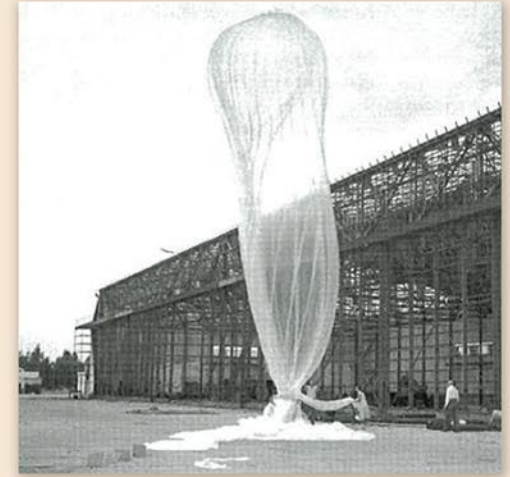

The large balloon, used by physicists in Lund, ready for its ascent at Cagliari Elmas Airport on the island of Sardinia in June 1952.



Accelerator-based research

The method used by the group in Lund was accurate but time-demanding. It was time for a transition to accelerator-based particle physics.

Photographic emulsions were still providing important results. Primary cosmic radiation consists of protons, helium nuclei and heavier atoms in the proportions 100:10:1.

Primary radiation was detected in the emulsion stacks exposed at Fort Churchill in the Canadian Arctic, where the incoming particles are affected by the earth's magnetic field. Considerable similarities were found with the charge distribution and occurrence of the elements in our galaxy.

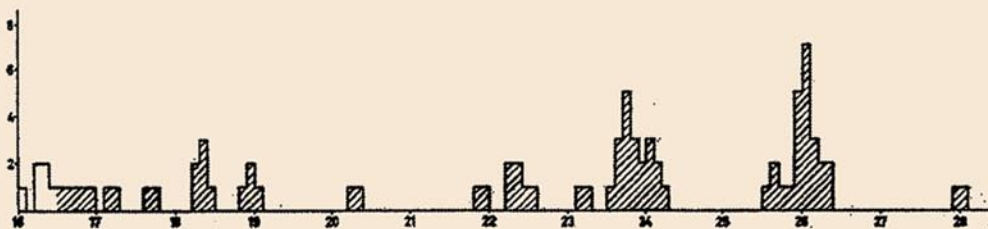
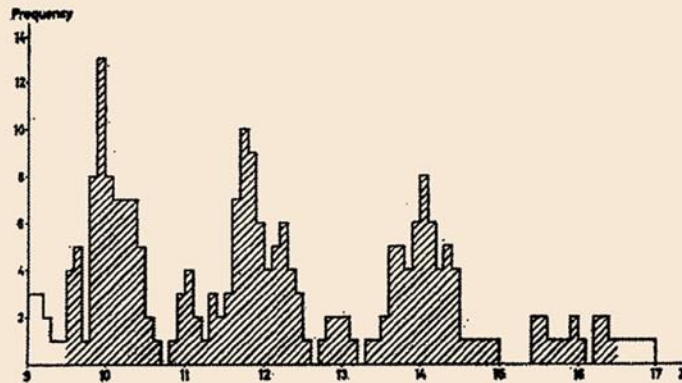

▨ One particle

Spectrum of relativistic atomic nuclei in the primary cosmic radiation interval from neon to nickel.

Multifragmentation

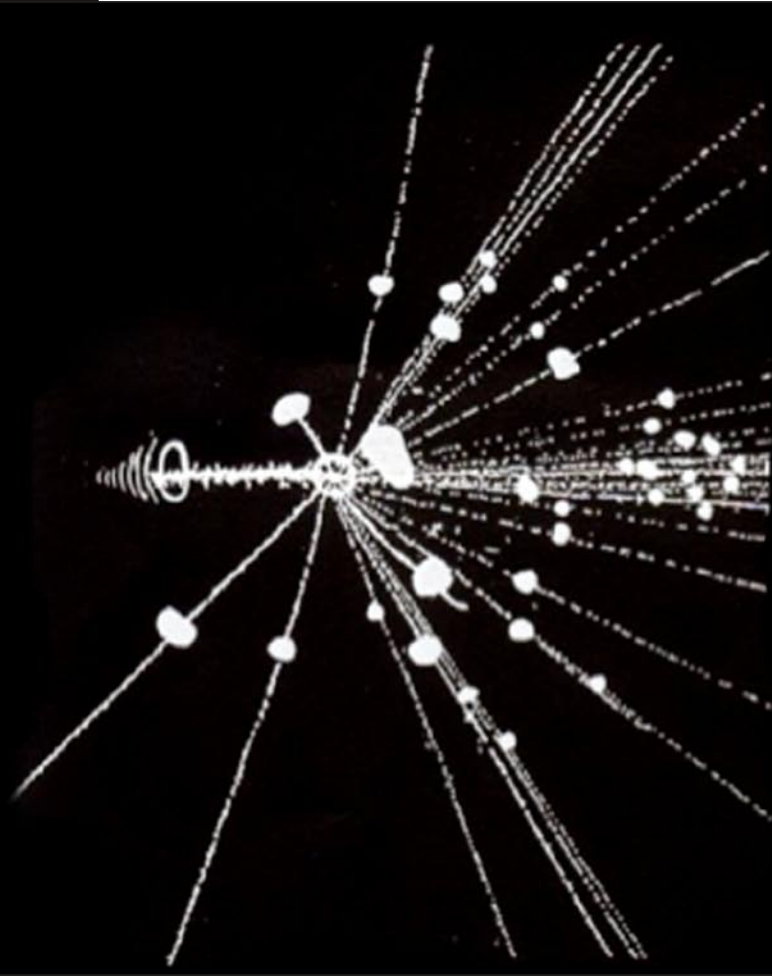

At the beginning of the 1970s, the new accelerators in Dubna (former USSR) and Berkeley (USA) began to deliver well-defined heavy-ion beams, and new electronic detector technology revolutionized research in this field.

Scientists at Lund had to adapt to these new techniques, but thanks to their considerable knowledge and skills regarding nuclear emulsions they were able to demonstrate the possibilities of these new techniques. They analysed the rare 'stars' that appeared in emulsions when high-energy particles collided with nuclei in the emulsion. Fragments with different masses are created, which spread out from the point of collision in a star-like pattern. This process is called multifragmentation.

A classical photographic emulsion from 1975 of an almost symmetric collision between ^{84}Kr and ^{80}Br at an energy of about 1 GeV per nucleon. The person scanning the image was asked to label the tracks with dots proportional to the size of the fragments.



Nuclear states

Bo Jakobsson was responsible for the research development of multifragmentation in Lund. He had studied theoretical physics for three years at NORDITA, the Nordic Institute for Theoretical Physics, in Copenhagen, where he got to know the theoretician Jakob Bondorf. This laid the foundations for the understanding of the behaviour of nuclei at extremely high temperatures. Jakobsson collected a group of physicists from Lund with good knowledge of detectors, and together they performed experiments at the synchrotron at CERN.

The next stage involved travelling to a number of large accelerators to carry out detailed studies on the fragmentation process through ultra-fast studies of neutron and proton emission.

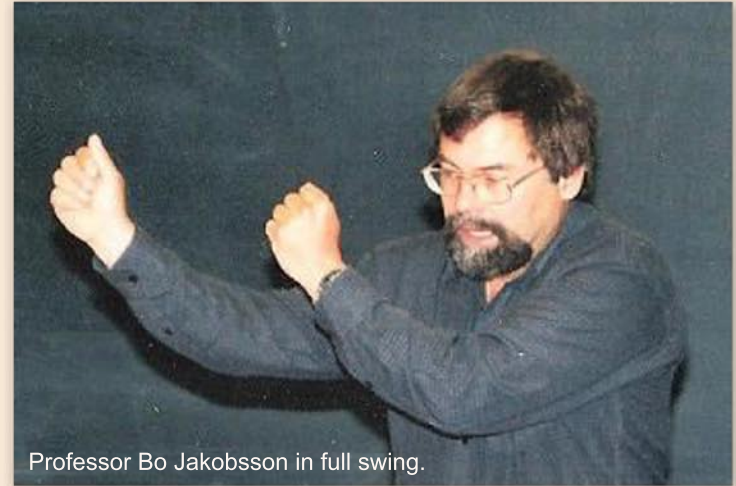

Professor Bo Jakobsson in full swing.



Slow ramping mode

Theoretical developments proceeded quickly alongside experimental studies. Theoreticians predicted a phase transformation of nuclear matter at high temperatures, in which the material became a phase consisting of subatomic fragments. Experiments showed that the theoreticians were right.

Experiments carried out by Lund physicists at the CELSIUS accelerator in Uppsala were decisive. This accelerator could be run in *slow ramping mode*, which meant that it was possible to accelerate protons from 200 to 500 MeV over a period of four minutes and thus study how fragmentation changed with increasing excitation energy.

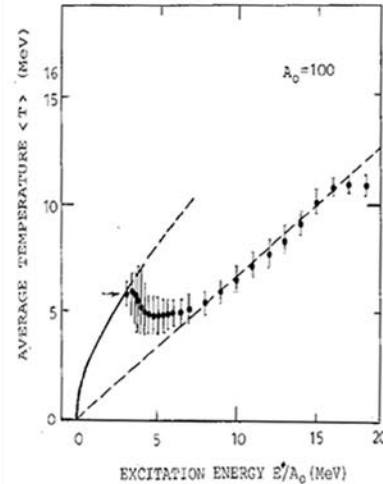

Theoretically calculated curves showing the average temperature as a function of the excitation energy according to the Copenhagen multifragmentation model for decaying $A=100$ nuclei.

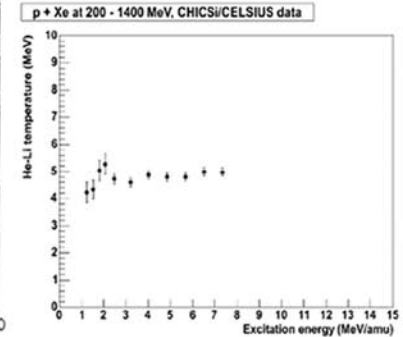

Experimental results showing the same relation as that on the left for $p + \text{Xe}$ collisions at the CELSIUS storage ring in Uppsala, using *slow ramping mode*.



Cosmology

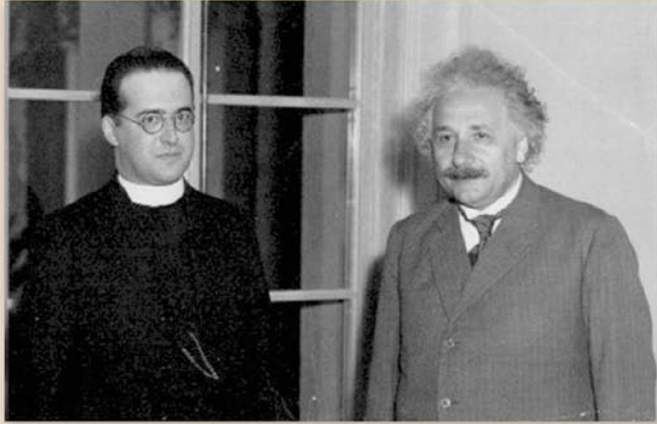

Georges Lemaitre (1894 - 1966) and Albert Einstein (1879 - 1955).

Albert Einstein tried to create a static theoretical model of the universe. In order to prevent it from collapsing under the force of gravity, he introduced the cosmological constant, Λ .

George Lemaitre was a Belgian priest serving the Vatican, as well as professor of physics and astronomy. He proposed the theory of the expanding universe.

The cosmological principle states that the universe is isotropic and homogeneous when viewed on a large enough scale, for example, millions of light years. This principle is based on Albert Einstein's general theory of relativity, Georges Lemaitre's calculations and Hubble's observations that the universe is expanding.

According to the Big Bang theory, all the material in the universe was initially in the form of a plasma containing quarks and gluons – the quark–gluon plasma (QGP). For some unknown reason, there were slightly more particles than antiparticles. The protons and neutrons making up nuclei as we know them today were formed from this plasma when the universe was 10^{-5} seconds old.



The Lund model

Physicists have come increasingly closer to the high temperatures that characterize the QGP. This is achieved when heavy ions collide with each other in the world's most powerful accelerators.

Researchers from Lund have taken part in experiments designed to reach ever higher temperatures in nuclear matter in the search for new phase transformations.

Theoreticians and experimentalists at Lund together developed what is known as *the Lund Model*, in which gluon strings stretch between the quarks. When these strings break, a large number of observable particles are formed, mainly mesons. This model is now world famous.

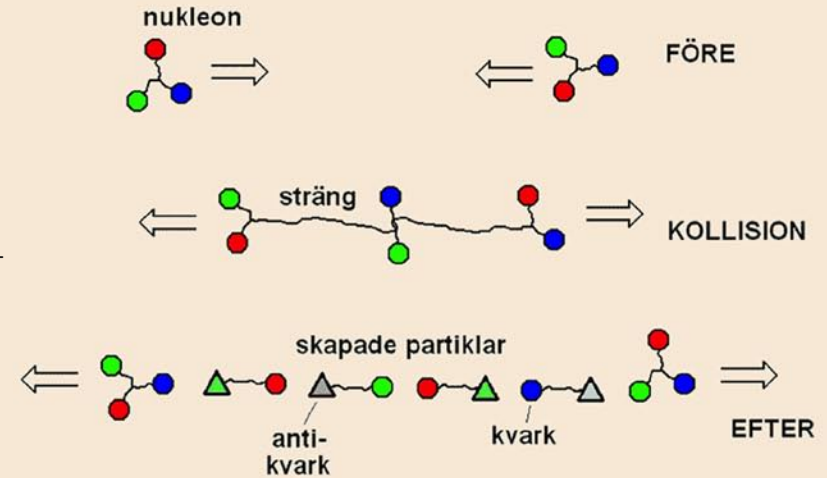

Schematic illustration of the fragmentation of gluon strings according to the Lund Model.



Heavy-ion collisions

The heavy-ion experiments carried out by Lund researchers at the Intersecting Storage Rings (ISR) at CERN, where atom-on-atom collisions are being studied, were led by Ingvar Otterlund. Studies on the QGP continued at the Super Proton Synchrotron (SPS) at CERN, where even higher energies were achieved by Pb–Pb collisions.



Ingvar Otterlund,
Professor Emeritus
of Particle Physics.



Evert Stenlund,
Professor
of Particle Physics.

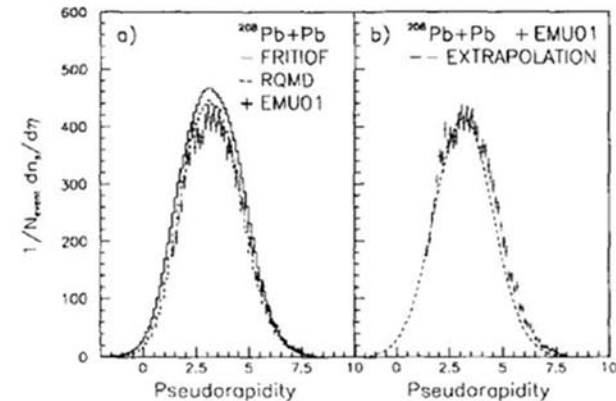

Experimental data and simulated results of Pb-Pb collisions.

Detector systems



Particle physicist and Professor Hans-Åke Gustafsson (1945-2010) played an important role in this field of research over a period of 30 years.

During the 1990s, the Lund group was active in the construction of the PHENIX experiment at the Heavy-Ion Collider at Brookhaven National Laboratory in the USA. The main task of the group was to develop a specific detector system, the so-called pad chambers. These are large multi-wire proportional detectors filled with gas that record the passage of charged particles with high efficiency and precision.

The Lund group is in the 2010s back at CERN using the most powerful accelerator in the world to date: the Large Hadron Collider (LHC). The group is involved in the ALICE experiment with a new detector system – the Time Projection Chamber.



A world record!

Temperatures above 5×10^{12} °C have been reached with the ALICE experimental set up, which means that a QGP has been achieved like the one that existed only a millionth of a second after the Big Bang.

This was reported in the Swedish media on August 16th 2012:

Five thousand billion degrees – the highest temperature ever achieved by man – has been reported by researchers at the LHC at CERN in Switzerland. Scientists have achieved the highest temperature in matter ever recorded by colliding lead atoms at high energy in an accelerator.

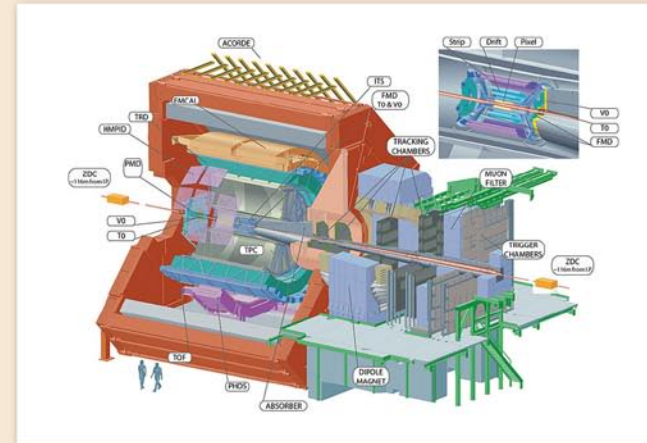

Alice

When the universe was young

Anders Oskarsson,
Professor of Particle Physics,
from Lund University.



Following the announcement on national radio, Anders Oskarsson, was interviewed.

It has taken two years to determine how high the temperature was during the experiment. Analyses like these take time. When material is heated to high temperatures its nature changes, like when water is heated to produce steam. The temperature of the water doesn't increase as more energy is added, but steam is produced instead. We have studied the process when protons and neutrons split into quarks in an analogous way, by measuring the temperature on this side of the phase transformation.

This new record is about 40 % higher than the previous one, which the Lund group was also involved in.

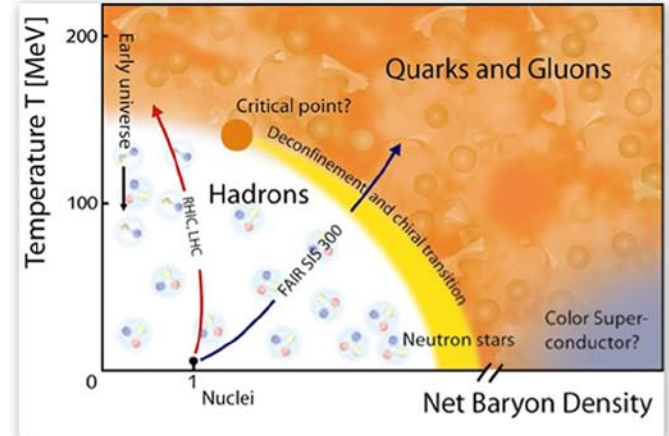

A phase diagram illustrating the transformation of normal matter into free quarks and gluons.

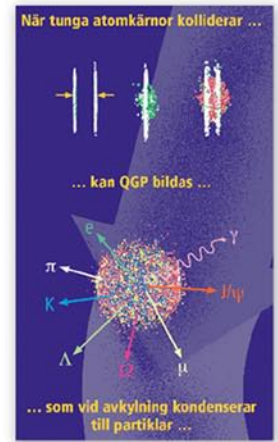

Phase transformation takes place when material is heated to high temperatures, as in heavy-ion collisions. When the material expands and cools, the reverse process takes place, similar to that when the universe was very young.

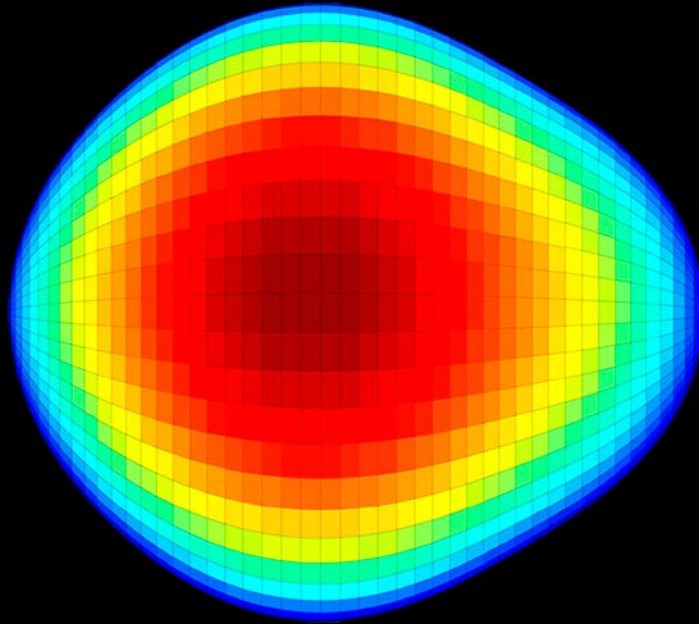

The nucleus in the spotlight

The development of nuclear physics in Lund – electrostatic accelerators, electron accelerators, Ur-MAX, LUSY, MAX-lab and some aspects of applied nuclear physics.



The development during 1896–1939

One could say that nuclear physics was born in 1896, with the findings of Henri Becquerel concerning phosphorescent crystals.

Becquerel hypothesized that phosphorescent materials, such as some uranium salts, might emit penetrating X-ray-like radiation when illuminated by bright sunlight. His first experiments appeared to confirm this. However, by May 1896, after other experiments involving non-phosphorescent uranium salts, he arrived at the correct explanation, namely that the penetrating radiation came from the uranium itself, without any need for excitation by an external energy source.



Henri Becquerel

Image of Becquerel's photographic plate which has been fogged by exposure to radiation from a uranium salt. The shadow of a metal Maltese Cross placed between the plate and the uranium salt is clearly visible.

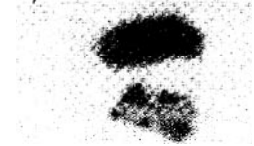

Scattering of α -particles against a gold foil, 1911.

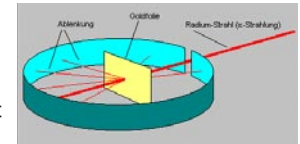

Ernest Rutherford

The first nuclear reaction was carried out in 1919: $\alpha + {}^{14}\text{N} \rightarrow \text{p} + {}^{17}\text{O}$.



James Chadwick

The neutron was discovered in 1932.

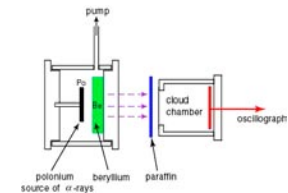



Nuclear physics comes to Lund

The dropping of the atomic bombs on Japan in 1945 changed the world, and nuclear physics became a new area of research, even in Lund.

Manne Siegbahn's PhD student, Sten von Friesen, arrived in Lund in 1946, and was housed in a temporary building with four small rooms. In one of the rooms Hellmuth Hertz was planning the installation of a Van de Graaff accelerator, while in another a Wilson cloud chamber was being constructed for the detection of cosmic radiation. In the fourth room, Krister Kristiansson analysed nuclear emulsions, while Sven Johansson developed electronic gamma detectors.



The research group in nuclear physics in the mid 1950s.

Inserted above from the left: Eskil Möller, Bibijana Dobovisek, Lennart Stigmark, Berndt Waldeskog.

Above from left: Erik Alinder, Börje Persson, Åke Isberg, Nils Norlind, Erik Hellstrand, Lars Hansson, Per-Olof Fröman, Uno Persson.

In the middle from the left: Nils Starfelt, Nils Svantesson, Laboratory assistant, Elvir Andersson, Bengt Forkman, Hans Ryde, Kjell Jönsson, Börje Pettersson, Jan Cederlund.

In the front from the left: Göran Leide, Birgit Lindqvist, Holger Sköldbörn, Sven Johansson, Sten von Friesen, Kurt Lidén, Krister Kristiansson, Hellmuth Hertz.



Building accelerators

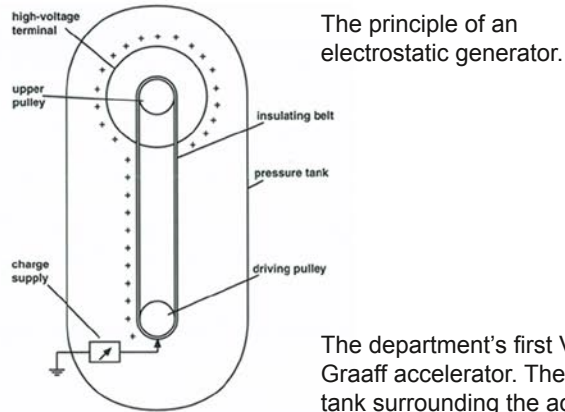

The department's first Van de Graaff accelerator. The pressure tank surrounding the accelerator can be seen in the foreground.

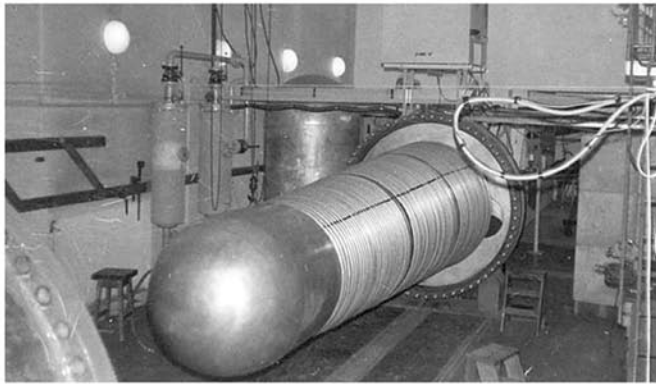

Sten von Friesen travelled to the USA to study new accelerators. He decided that a Van de Graaff accelerator was ideal since it was possible to carry out precise measurements with such a machine, while being relatively inexpensive to run.

A newly formed group started to construct their own Van de Graaff accelerator in what is now the department's library.

The accelerator consisted mostly of homemade components, and was completed and ready for use in 1956.



Accelerated protons

The Van de Graaff accelerator could produce high voltage up to 3 MV. It was used to accelerate protons, which led to different kinds of processes when they collided with atomic nuclei. For example, Ingvar Bergqvist and Nils Starfelt studied fast neutrons resulting from these collisions.

These neutrons could in turn be captured and bound in other nuclei; a process of considerable theoretical interest. Fast neutrons can combine with the lead nuclei in two ways: Directly or indirectly via a resonance. Both capture processes are involved.

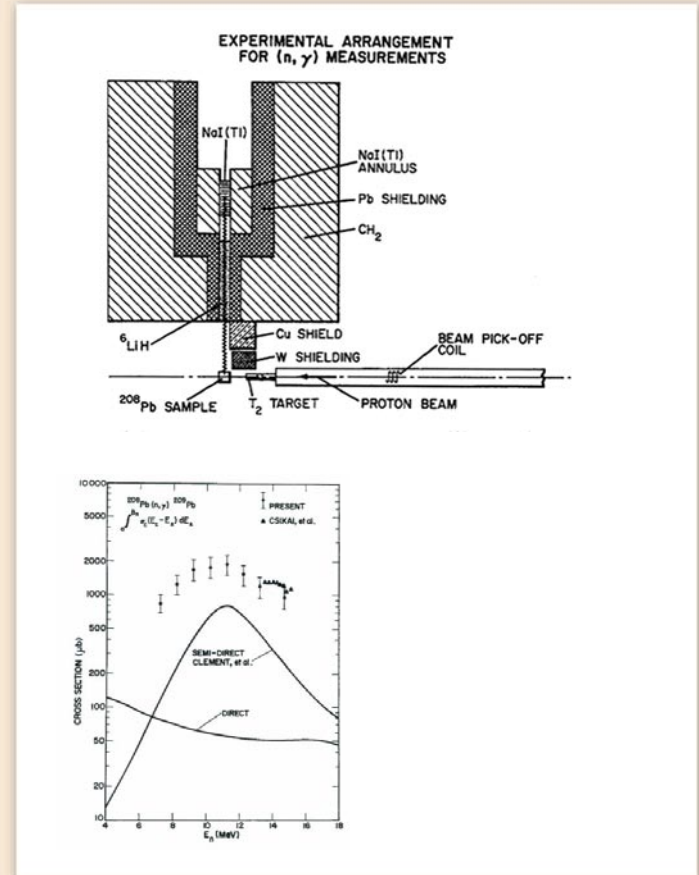

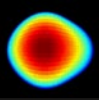

The pelletron accelerator

In 1972 the Van de Graaff accelerator was replaced with a new electrostatic accelerator, a *Pelletron*, in which the charge is transported by a chain of metal spheres called pellets, hence the name.

A voltage of 6 MV could be obtained with this accelerator, and it was to prove important for the Department of Physics. Apart from basic nuclear physics research, the PIXE method (particle-induced X-ray emission) for the analysis of trace elements was developed by Sven Johansson using this accelerator.

The technical head of the new Pelletron laboratory was Ragnar Hellborg, who held the position for over 30 years. He was assisted by two research engineers, Kjell Håkansson and Christer Nilsson.



Ragnar Hellborg,
Pelletron specialist.



Kjell Håkansson
research engineer
and recipient of a
prestigious award
from the Swedish
Academy of Engine-
ering Sciences (IVA).



Christer Nilsson,
research engineer
and top-level cyclist.

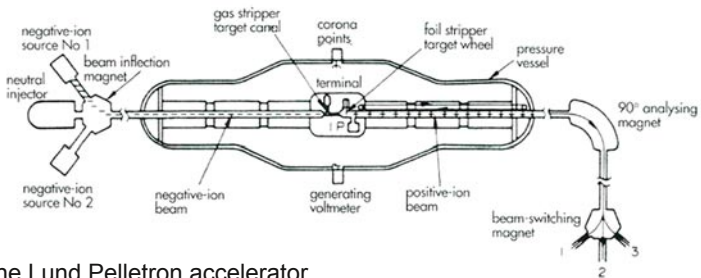

The Lund Pelletron accelerator.



Isotope production for medical studies

The isotope ^{18}F is produced by the nuclear reaction $^{18}\text{O}(p,n)^{18}\text{F}$, and is used in human medical investigations. After irradiation of ^{18}O -rich water with protons, the ^{18}F atoms are extracted and injected into the patient. The host molecule is incorporated into the metabolism in the patient's body and collects in tumours. The radiation from the decay of the ^{18}F atom is then measured.

The method is called positron emission tomography (PET), and provides a three-dimensional image of the region being studied.

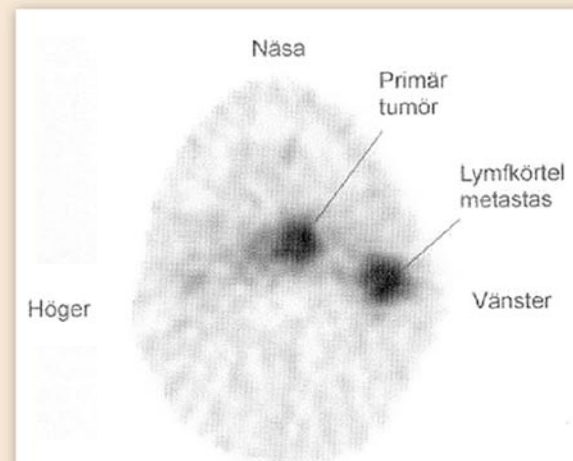

These early PET studies were made possible by Ragnar Hellborg, and provided the basis for the further development of medical radiation physics.

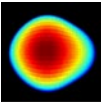

^{14}C – a versatile tool

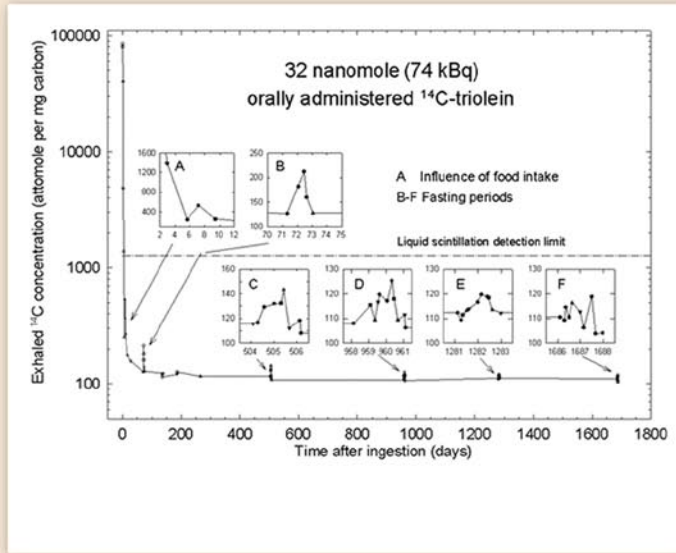

During the 1990s, the Pelletron accelerator was adapted for mass spectrometric analyses of several rare isotopes, mainly the detection of ^{14}C in geological, archaeological, environmental radiological, and medical studies.

An example is given in the figure to the left, which shows how the technique is used to determine the radiation dose to a person from a ^{14}C -labelled pharmaceutical. Traces of the radionuclide could be detected in the patient's breath four years after the pharmaceutical had been administered. Kristina Eriksson Stenström has developed this and other methods.



Meteorite showers



A possible meteorite impact.

Luis Alvarez hypothesis that the dinosaurs died out as the result of a collision of an asteroid with the earth is based on measurements of iridium close to the impact site. Asteroids have higher iridium contents than the earth's crust.

Per Kristiansson and Birger Schmitz' group at the Division of Nuclear Physics constructed an advanced Iridium Coincidence Spectrometer (ICS) for geological stratigraphic studies of iridium that provide evidence of other major impacts during the earth's history.

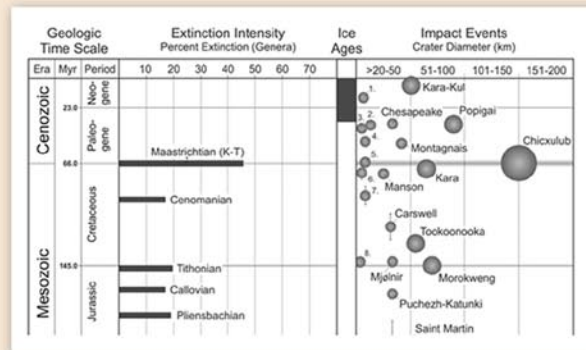



The giant resonance

When high-energy photons impinge on an atomic nucleus it starts to vibrate. Photons were produced by a 35 MeV electron synchrotron which was donated to the department by the Royal Institute of Technology (KTH) in 1953. This machine became known as *Ur-MAX*.

Resonant vibrations are created between the protons and neutrons in the nucleus by photons in the energy range 15 - 35 MeV. Surprisingly, the resonance showed a clear structure. This structure provided strong evidence of the validity of the shell model of the nucleus, which states that individual nucleons move in well-defined orbits, despite the fact that the nucleus is so dense.

Pioneers in the field were Sven Johansson and his PhD student Bengt Forkman.

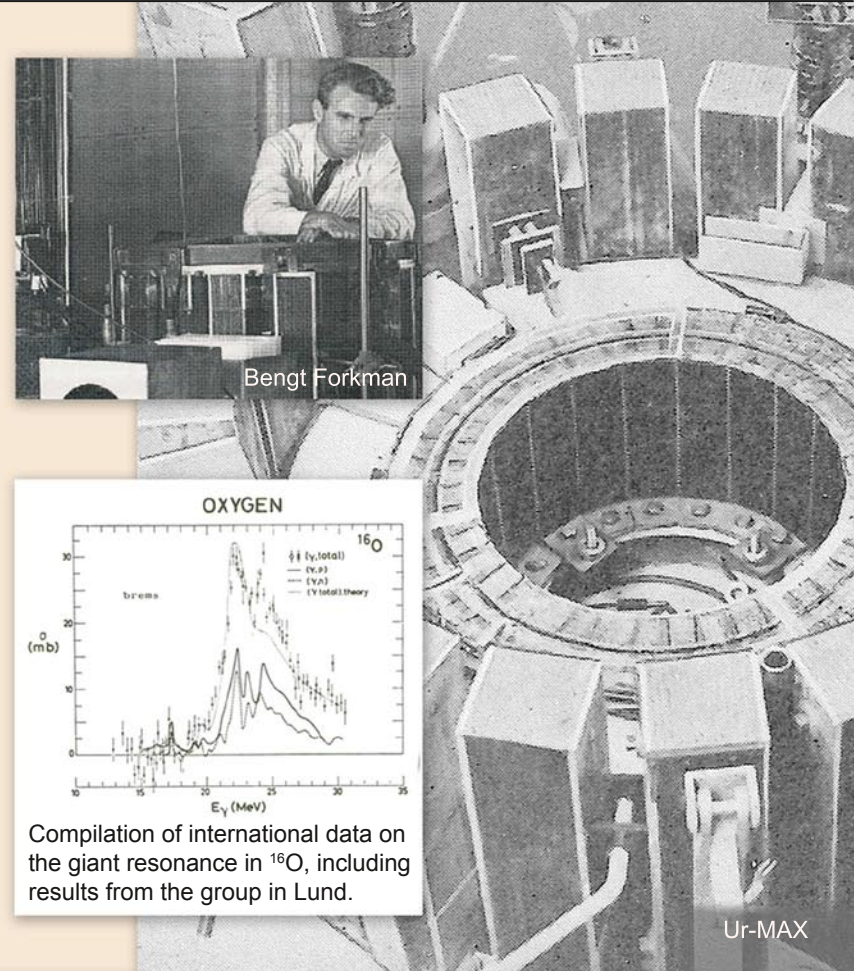

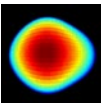

LUSY



The 1.2 GeV electron accelerator, LUSY.

When the 1.2 GeV (1 200 MeV) electron synchrotron LUSY was inaugurated in 1962, the Photo Nuclear group, under the leadership of Bengt Forkman, began a series of studies on high-energy photoreactions way above the giant resonance at about 20 MeV.

At photon energies around and above 150 MeV, other absorption processes, called Δ resonances, take place. The direction of spin of one of the three quarks in the target nucleon can be reversed, leading to increased adsorption. During de-excitation photopions can be emitted.

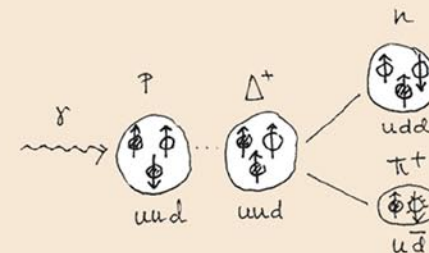

Schematic illustration of the spin flip of a quark in a nucleon.

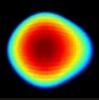

Tagged electrons

When it was time to decommission LUSY, plans were initiated for a new facility for nuclear photoreaction experiments. These plans developed into what later became MAX-lab, where nuclear photoreaction physics was carried out until Spring 2015.

A large part of the equipment is dedicated to a technique called tagging, where single photons with a specific energy can be labelled or tagged. This allowed experiments to be carried out with photons of well-defined energy.



Kurt Hansen and Bent Schröder beside the tagging magnet.

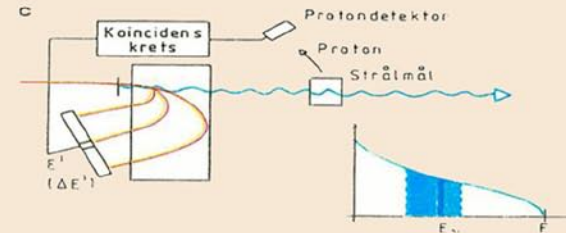

The electron, which has been slowed-down, is deflected in a magnetic field and then detected in one of many detector traps. This provides the energy of the electron, and the energy of the initial photon can then be determined.



Experiments at MAX-lab

There is reason to believe that photons with an energy above the giant resonance, but under the threshold for photopion production (30-150 MeV), interact with quasideuterons, i.e. unstable neutron-proton pairs. Bent Schröder took over the leadership of the nuclear photoreaction group when MAX-lab became available for experiments.

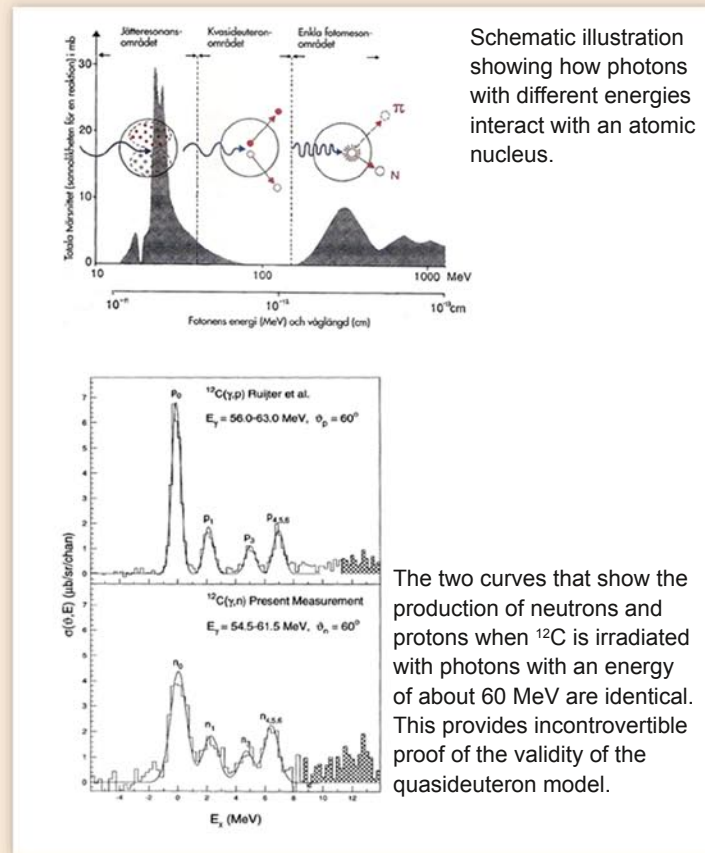

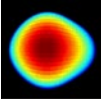

Rotating nuclei

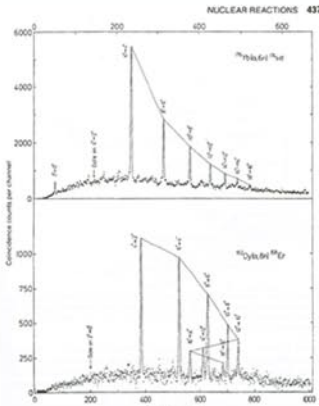

Rotation spectra from excited Hf and Er nuclei.

Below:
Values of nuclear angular momentum as a function of the square of the angular velocity.

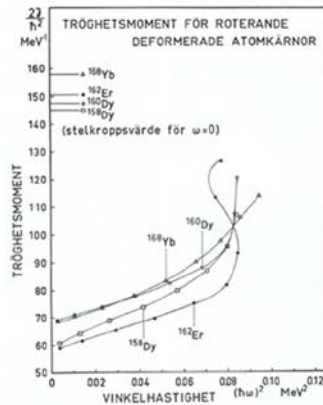

Hans Ryde took over from Sten von Friesen in 1975. Ryde was interested in the motion of particles inside the nucleus. Irradiating a nucleus with α -particles can cause it to rotate. At nuclear spins above 14^+ , the energy of the nucleus shows a dip or minimum; something happens to the nucleus at the quantum number 16^+ . The nucleons in the nucleus normally rotate in pairs, but at high rotational energies this coupling is broken by the Coriolis force.

In 1972 Hans Ryde and his group, working in Stockholm, discovered the so-called backbending effect in rapidly rotating nuclei.



New detectors

Much of what we know today about the atomic nucleus originates from experiments and measurements on γ rays. The transition from Geiger-Müller tubes and NaI(Tl) crystals to solid-state Ge detectors, combined with fast electronics made it possible to obtain γ ray spectra with considerably higher energy resolution. These have provided a great deal of knowledge on atomic nuclei.

The nuclear structure group in Lund has also contributed to this development.

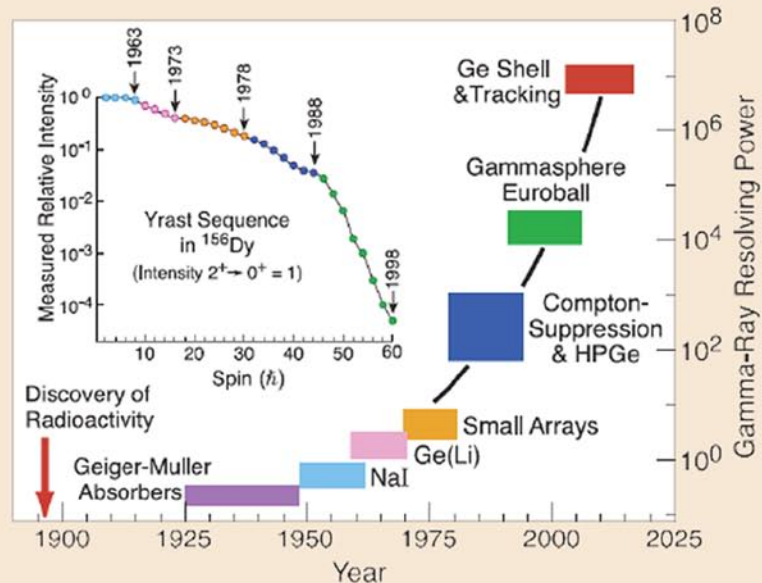

The development of γ -ray measurements.

The *yrast* level in a nucleus with a given spin is the level with the lowest energy for that spin. This international term is derived from the Swedish word *yrast* meaning *the dizziest*.

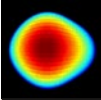

Today's nuclear structure researchers

When Hans Ryde retired, a new generation of nuclear structure researchers took over: Claes Fahlander (from Uppsala), Dirk Rudolph (from Göttingen, Germany) and Joakim Cederkäll (from Stockholm).

They are engaged in studying increasingly inaccessible nuclides, in an attempt to answer questions such as: How many, or how few, neutrons can exist in a nucleus with a given number of protons? How heavy can a nucleus be? When does a nucleus become so unstable, that it cannot exist as a nucleus?

In other words – How many elements are there in the period table?



Claes Fahlander



Dirk Rudolph



Joakim Cederkäll



New element

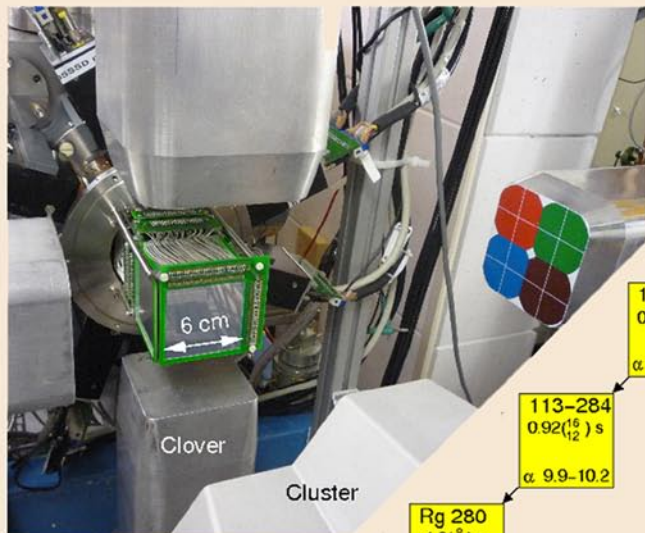

The 2013 Scientific Report from GSI Helmholtzzentrum für Schwerionenforschung in Germany shows the experimental set-up used to study the decay chain of the isotopes 288-115, which was studied for the first time with high-resolution spectroscopy. A total of 30 atoms of the element with the atomic number 115 were identified during the 3-week experiment, during which a thin foil of radioactive ^{243}Am was bombarded with 6 trillion (10^{12}) ^{48}Ca ions.

The experiment was led by Dirk Rudolph, and involved no less than 51 collaborators, six of which were from Lund.

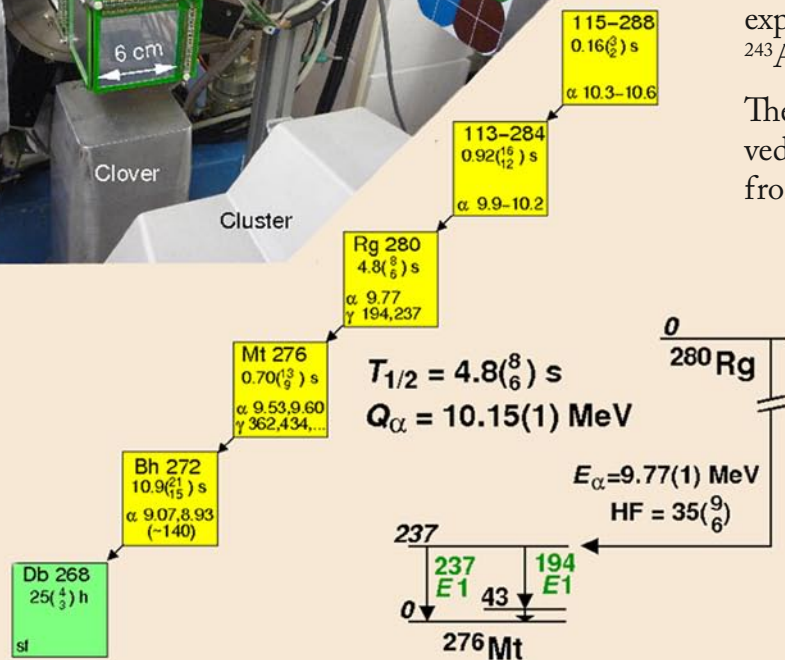

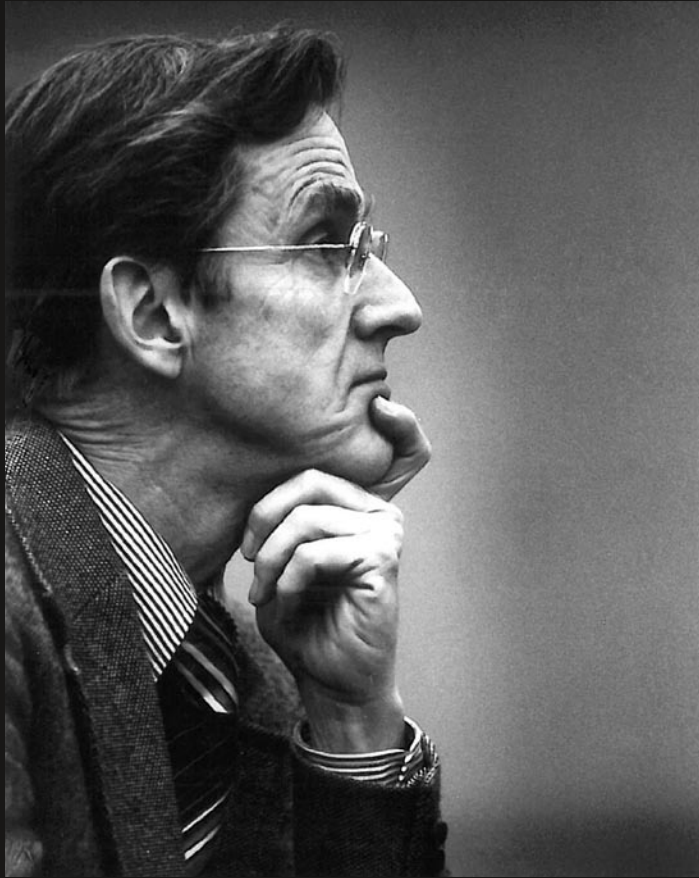

Sven Johansson and environmental physics

The chemical engineer who became a nuclear physicist, environmental physicist and Vice-chancellor of Lund University.

From chemistry to nuclear physics

Sven Johansson was born in 1923. After graduating from high school in Malmö, he studied chemical engineering at the Royal Institute of Technology (KTH) in Stockholm, and obtained his degree in 1944.

Like many other science students he was fascinated by modern physics, especially the new discoveries concerning the atomic nucleus. He therefore started his postgraduate studies at the newly established Division of Nuclear Physics in Lund.



Gamma spectroscopy

Sven Johansson obtained his doctorate in nuclear physics in 1952. In his thesis he described a new kind of gamma detector, a so-called scintillation detector using a NaI crystal as the detector material. He was one of the pioneers in this field, and developed the detector using the coincidence technique into the pair spectrometer, and quickly became internationally known.

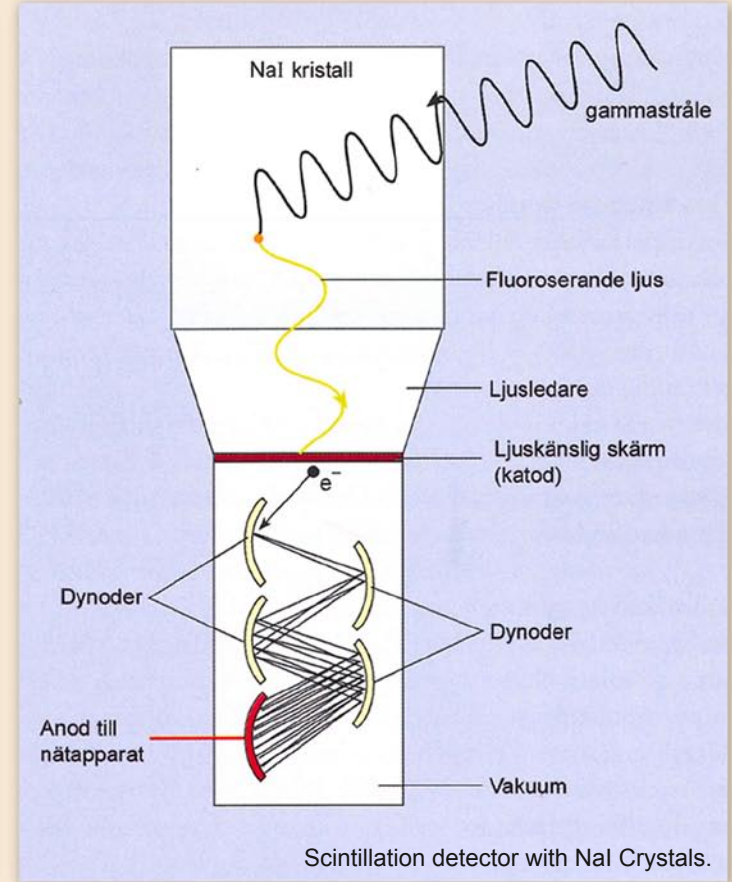
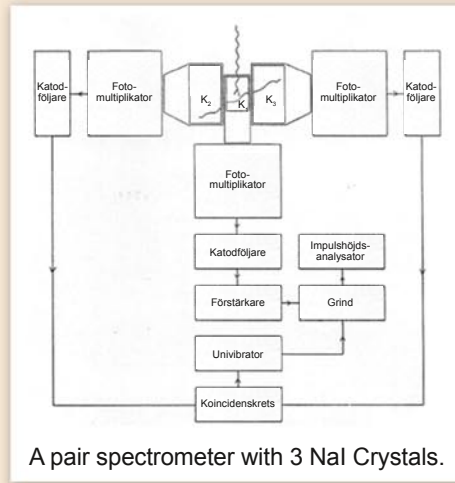

The 35 MeV synchrotron

In 1953, Sven Johansson worked at Iowa State College in the USA, where he conducted research using a 60 MeV electron accelerator. When he returned to Lund, the 35 MeV synchrotron built at KTH had just been installed, and experiments on photon-induced nuclear reactions, so-called photonuclear reactions, started immediately. The very first experiment, on the distribution of energy of photoprotons when the oxygen nucleus was irradiated, attracted considerable international interest.

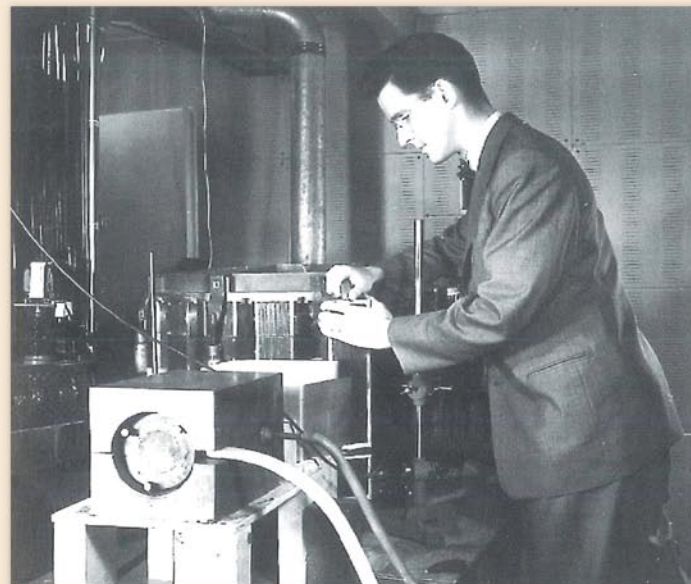

Sven Johansson at the 35 MeV synchrotron in Lund, showing the set-up used for the oxygen nucleus irradiation experiment in 1965.

The giant resonance

Atomic nuclei absorb gamma rays over a broad energy interval of 15 - 25 MeV. This is called the giant resonance. According to the liquid drop model for atomic nuclei, oscillations arise when groups of neutrons and protons vibrate against each other.

According to the shell model, the protons and neutrons in the nucleus move in discrete shells with defined quantum numbers. The giant resonance can also be explained with this model, but it was predicted to also have a fine structure. This was exactly what the experiment in Lund demonstrated.

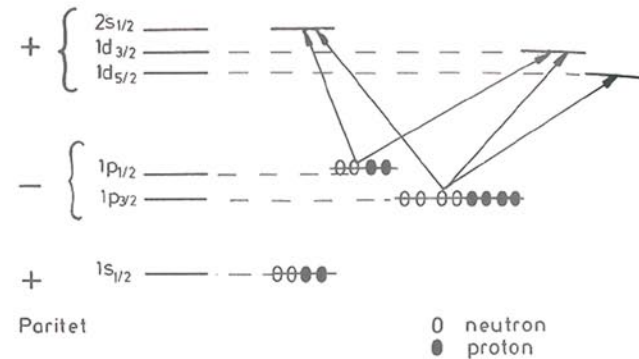
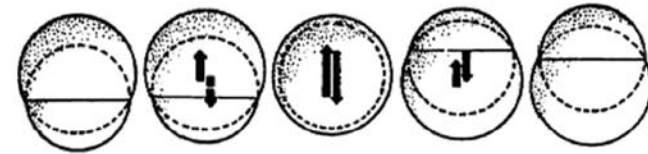

A particle-hole transition according to the shell model.

The structure of the giant resonance

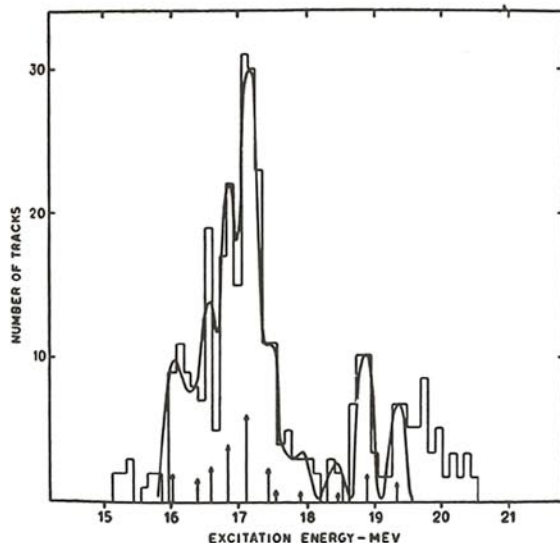

Spectrum showing the energy distribution of photoprotons from an oxygen molecule.

The oxygen nucleus (^{16}O) was irradiated with gamma rays from the synchrotron, causing it to become excited. Protons were emitted from the excited nucleus, and detected by the tracks made in photographic emulsions. The energies of the protons could then be determined from these tracks.

Not only did the energies of the protons agree with those predicted by theory, the angular distribution of the protons with specific energies was also in agreement with the shell model.

Fission and cosmology

Spontaneous fission

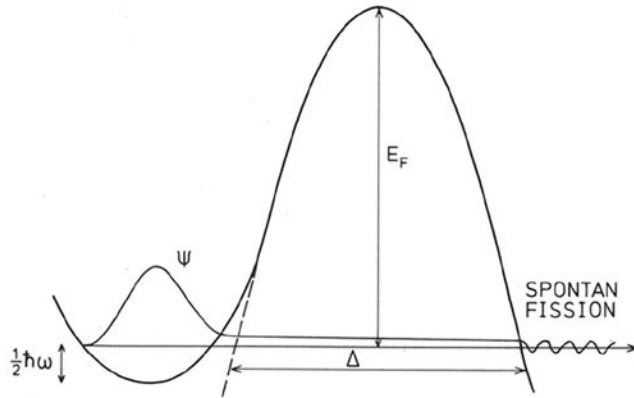

The wave function is leaking through the fission barriers and spontaneous fission occurs.

Sven Johansson also studied isotopes that undergo spontaneous fission, i.e. no extra energy is required to cause them to break up. He was one of the first to use Sven Gösta Nilsson's collective nuclear model to explain the process of fission. He also obtained good agreement between the model and experimental results. Together with his postgraduate student, Clas Otto Wene, he also suggested the existence of superheavy elements, an area of intense research by Sven Gösta Nilsson and his group in the 1960s.

Professor at LTH

In 1965, Sven Johansson was appointed professor at the newly established Lund Institute of Technology (LTH). Apart from nuclear physics, the research at his division was soon to take a new direction. Together with his PhD students, Roland Akselsson and Thomas B Johansson, Sven developed a new analytical method called PIXE – Particle Induced X-ray Emission – based on his experience in nuclear physics.



Roland Akselsson, Sven Johansson and Thomas B Johansson.

PIXE

The X-rays emitted in PIXE were detected and their energy was measured using the newly developed semiconductor detectors, which had a very high energy resolution. In normal X-ray analysis, the characteristic X-rays emitted by atoms when they are excited with high-energy electrons or broadband X-ray radiation, are measured.

Sven Johansson and his colleagues used protons from a Pelletron accelerator for excitation. In this way, they were able to avoid the high background radiation from excited electrons and gamma rays. The detection limit was reduced by a factor of 1 000.

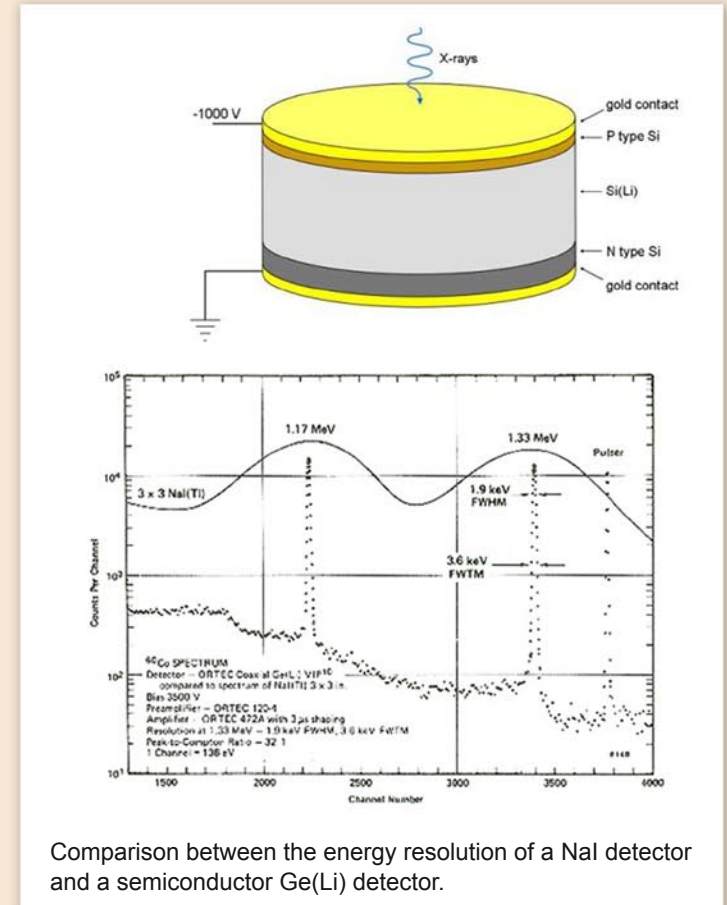

Comparison between the energy resolution of a NaI detector and a semiconductor Ge(Li) detector.

Characteristic X-rays

High-energy particles or X-rays can knock out an electron from an inner orbit in an atom. When the hole is filled by an electron from an outer orbit, a photon is emitted with a wavelength that is characteristic of that atom.

These were the wavelengths measured with high precision by Manne Siegbahn at the Department of Physics a hundred years ago. Using high-resolution Si(Li) detectors it is possible to determine the amounts of different elements in the same experiment. The low background in PIXE measurements allows the determination of levels as low as one part in 10^{-12} less than the sample.

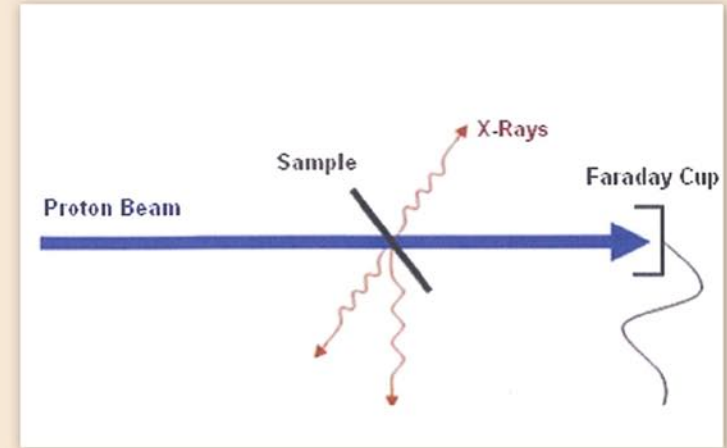

Environmental applications

By the beginning of the 1970s environmental problems such as acidification and air pollution had been identified.

The PIXE method was soon found to be suitable for the analysis of particles in the air (aerosols) collected on thin filters. At the same time, Sven Johansson was elected Vice-chancellor of Lund University and it was he who initiated the multidisciplinary *Environmental Management Programme*, in which knowledge and methods relevant for the understanding of the negative effects of transport and energy production on the environment were collected.

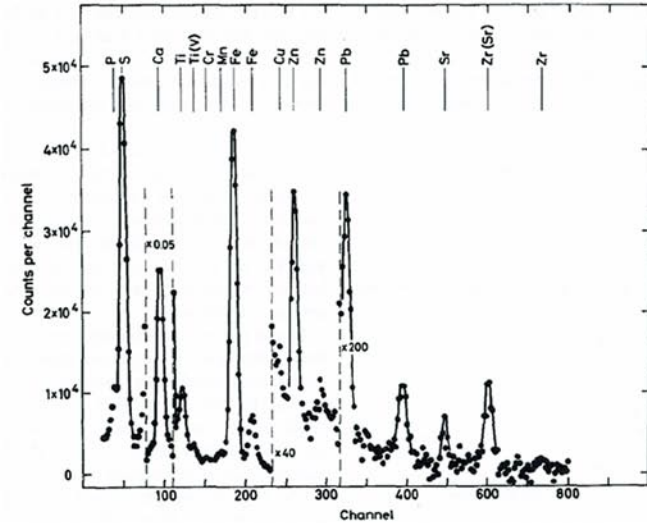

The spectrum obtained from matter deposited on a carbon foil left outdoors for one day shows the presence of significant amounts of sulphur and calcium, as well as zinc and lead, in the air we breath. Both K and L X-rays can be seen.



New accelerators



In 1972, a new accelerator and a 2*3 MV Pelletron replaced the old Van de Graaff accelerator, thanks to a grant from *Knut & Alice Wallenberg's Foundation*.

Activities involving PIXE expanded, and the PIXE group in Lund held a leading position in international circles. The fact that PIXE was developed at Lund has been of considerable importance for the development of the Department of Physics.

In 1989 a specially designed 3MV microbeam accelerator was installed for PIXE analysis.

PIXE experiments with participants from Lund

Tycho Brahe was a famous astronomer in the second half of the 16th century. When his tomb was opened in 1966, samples of hair from his beard showed high levels of mercury, indicating that he may have been poisoned. New samples were taken and analysed in 2010, which did not support this theory. Jan Pallon from the Department of Physics in Lund was a member of the team taking part in this study.

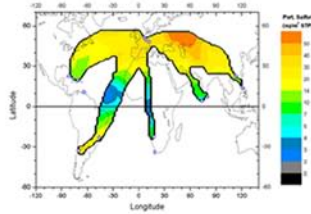

Research groups from six countries, including Bengt Martinsson from Lund, have together studied trace gases in the troposphere and stratosphere in an attempt to understand environmental atmospheric processes. Aeroplanes were equipped with measuring equipment allowing a large-scale study to be conducted on aerosols at these high altitudes.

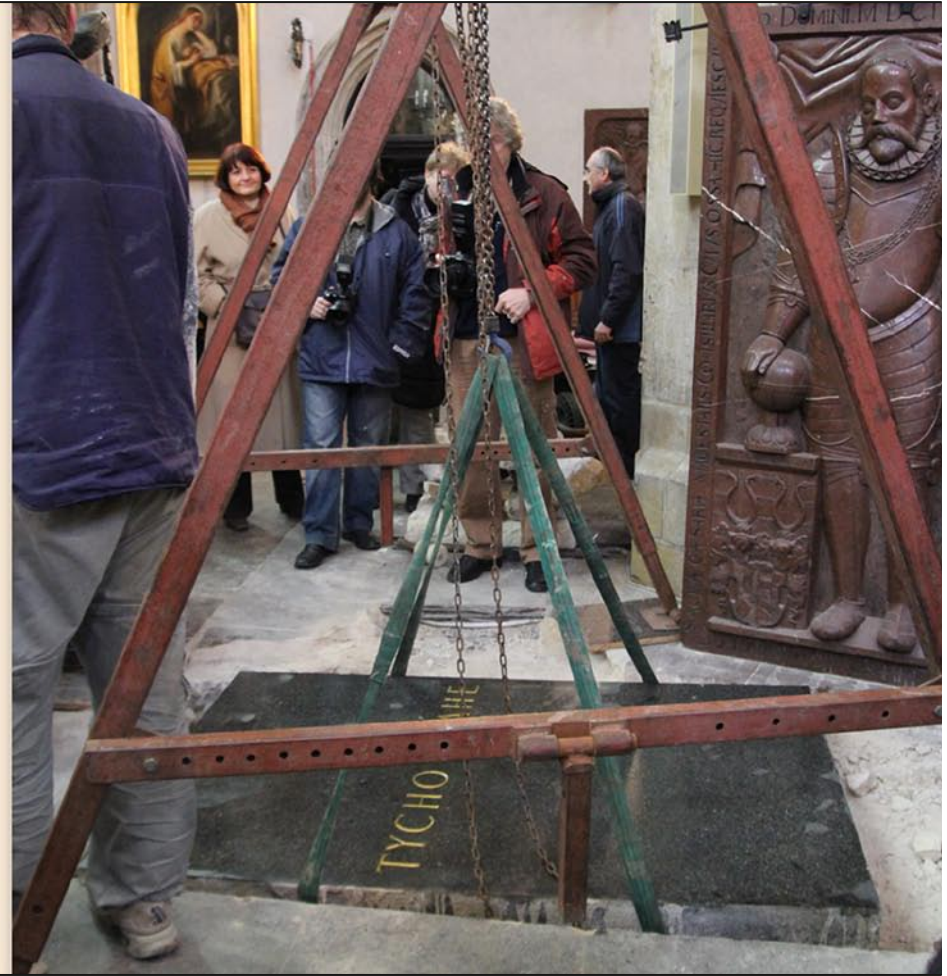

The leader

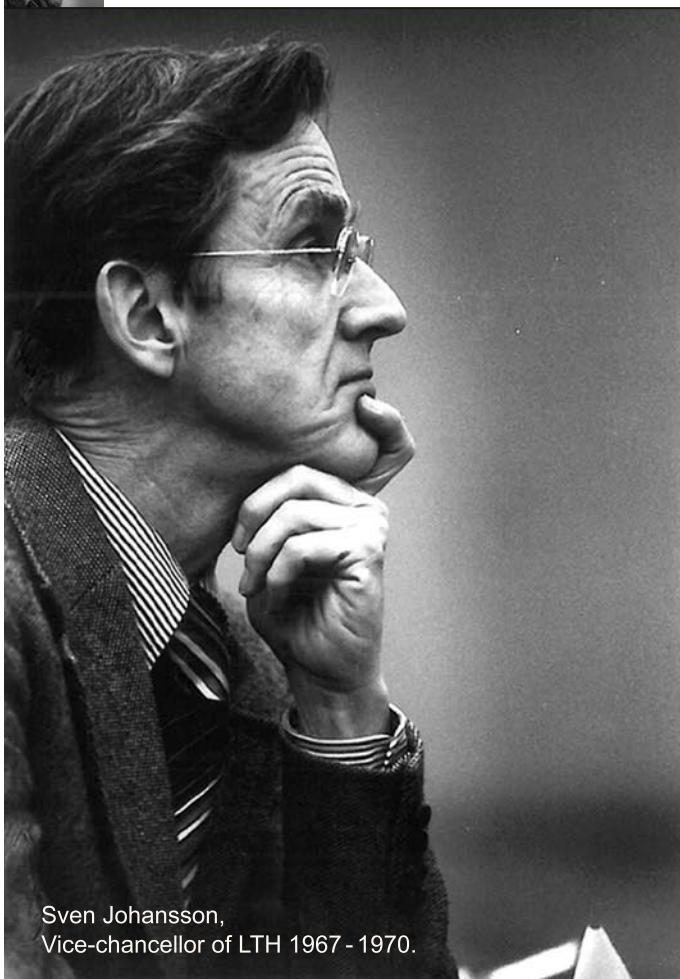

Sven Johansson,
Vice-chancellor of LTH 1967 - 1970.

After only four years in Lund, Sven Johansson won his colleagues' respect and was elected Vice-chancellor of LTH in 1967.

When it was later decided that LTH should become the Engineering Faculty of Lund University in 1970, the professors at LTH demanded that elections should be held for the position of Vice-chancellor of the University, and Sven was proposed as a most suitable candidate.

Rector Magnificus

The 1960s were characterised by student unrest in the Western world, and this reached its climax in Lund on 28 February 1969. During a meeting between representatives from industry and the University, students took over the lectern and turmoil broke out. In the end, the meeting had to be abandoned.

When electing a new Vice-chancellor of the University a year later, many believed Sven Johansson to be the right person to bring about reconciliation between teachers and students.



Sven Johansson,
Vice-chancellor of Lund University 1970 - 1977.

Research politics

Sven Johansson made important contributions to Physics in the Royal Swedish Academy of Sciences (KVA), and chaired the Nobel Committee for several years.

Sven was a staunch supporter of small successful research groups, and believed that large projects attracted so much funding, both nationally and internationally, that creativity in research suffered.

It was for this reason that he abstained when the Swedish Atomic Research Council (AFR) voted to support the expansion of CERN in 1971. He claimed it was a political decision, rather than a research decision.

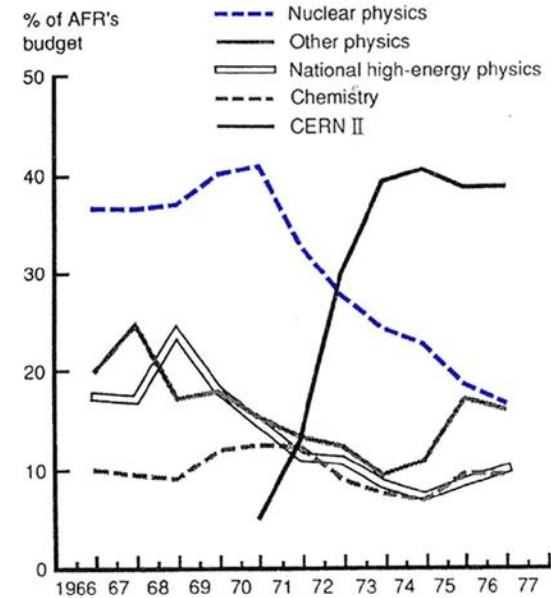

Distribution of government funds to various areas of physics, chemistry and CERN-based particle physics from 1966 to 1976.

The man



When Sven Johansson wasn't working, which he did almost all the time, he could be found with a book in his hand, or listening to classical music.

If he had any time over, he liked to drive big American cars or play tennis.

Sven Johansson together with his wife Aina, at the beginning of the 1950s.



Atmospheric aerosols

Particles and gases in the atmosphere form aerosols that can affect the climate and our health.



The advent of PIXE and its application to aerosols

One of the main advantages of PIXE (particle-induced X-ray analysis) is that it can be used to analyse several elements at once, in a very short time, in small samples. This makes the method suitable for the analysis of aerosol samples. An aerosol lab was established at the Division of Nuclear Physics at the end of the 1960s for just this purpose. In 1973, researchers at the division began collaborating with a research group at Florida State University in Tallahassee, USA. This contributed to the rapid development of sample collection techniques, and the use of PIXE to study atmospheric pollution in both Sweden and the USA.

The term *Aerosol* is derived from the Greek *aer* meaning air, and the Latin *solutio*, meaning solution. An aerosol consists of small particles dispersed in a gas. These particles can be solid or liquid, and the term aerosol includes both the particles and the gas.

Typical examples of aerosols are smoke, fog, and atmospheric pollution.

691215
Tom 8
"Balkongfilis I"

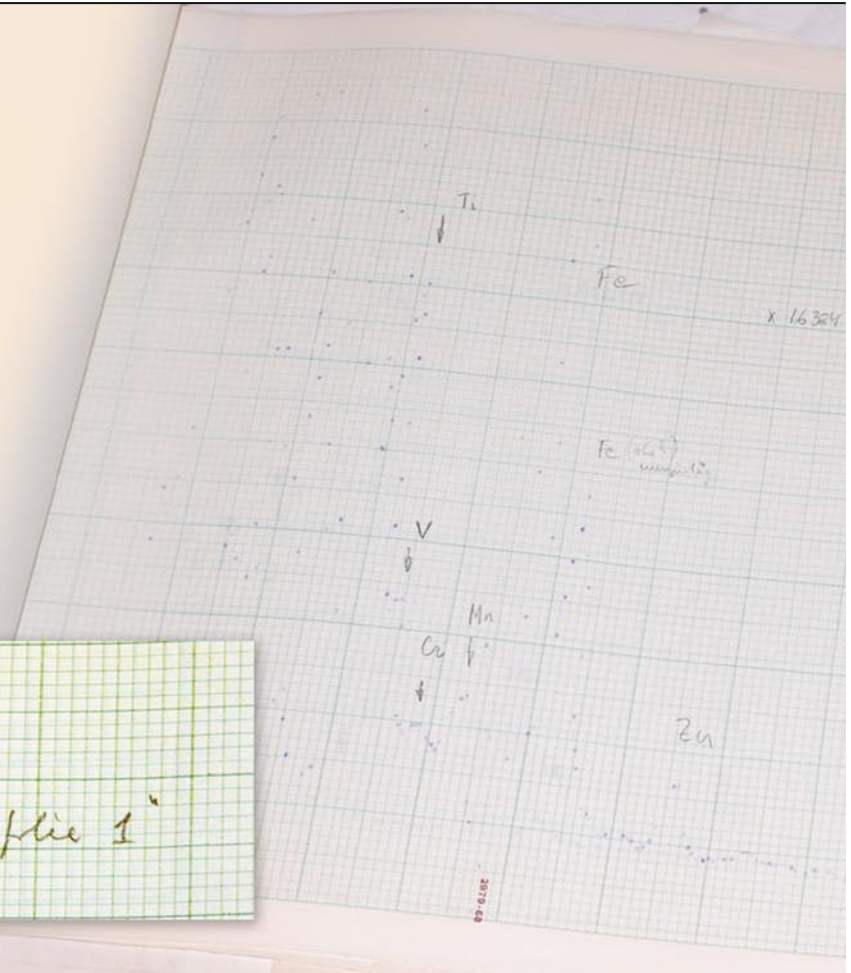



The first measurement

When the environmentally committed innovators of PIXE, Professor Sven Johansson and his PhD students Roland Akselsson and Thomas B Johansson, looked for suitable applications of PIXE in the early 1970s, they identified particulate air pollution, and this became the area that developed most rapidly.

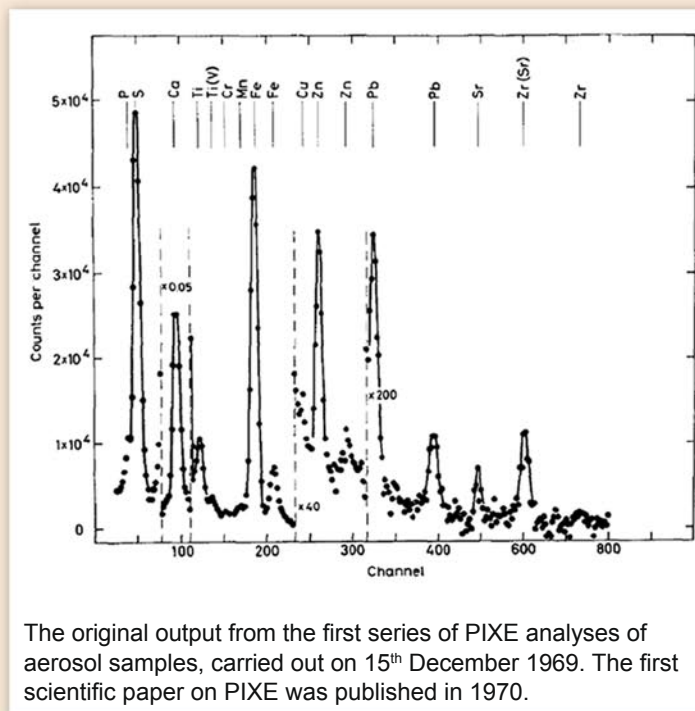

The original output from the first series of PIXE analyses of aerosol samples, carried out on 15th December 1969. The first scientific paper on PIXE was published in 1970.



Aerosol studies at the Division of Nuclear Physics



Hans-Christen Hansson, Professor at Stockholm University since 1994.



Bengt Martinsson



Erik Swietlicki



Birgitta Svenningsson

Bengt Martinsson, Erik Swietlicki, and Birgitta Svenningsson remained in Lund, and are involved in research on the effects of atmospheric aerosols on climate and health. Aerosols in the indoor environment are now being studied at the Division of Ergonomics and Aerosol Technology in Lund, but there are still strong ties between the two groups.

From the early work, a research group was formed to study atmospheric aerosols, including Hans-Christen Hansson, Bengt Martinsson, Erik Swietlicki and Birgitta Svenningsson. Initially, they studied the long-range transport of aerosols across national borders, and source–receiver studies related to the acidification of soils. Later, the relation between aerosols and climate became of interest, especially the interaction between clouds and particles.



Source–receiver modelling

One way of using PIXE to trace the source of particles in outdoor air is to look for characteristic *fingerprints*, which are related to the composition of the particles collected. It is then assumed that the particles emitted from different sources differ in terms of their elemental composition. Hans Lannefors and Hans-Christen Hansson performed the first studies as early as 1978, in Landskrona, to determine which sources influenced the air in the city, and several follow-up studies have been carried out there over the years.

Master's student, Hanna-Maria Frankman checks the sampling equipment in the harbour in Landskrona (2008). Boliden Bergsöe AB, a company that recovers lead from spent batteries, can be seen in the background.





Icebreaker expeditions in the Arctic

The Aerosol Group has participated in expeditions to the Arctic with the icebreaker *Ymer* in 1980, and with *Oden* in 1991, 1996, 2001 and 2008. The purpose of these expeditions was to study how particles are formed and how they affect the pure Arctic air found over the pack ice in the summer. These particles, in turn, affect the clouds and thus the radiation balance and ice-melting. Measuring the number of particles, and their physical and chemical properties in exceptionally clean air that is almost free of particles poses a considerable challenge.



The icebreaker Oden during the expedition to the High Arctic in the summer of 2001.



Cloud droplets

Cloud droplets form by the condensation of water vapour on aerosol particles, and particulate air pollution affects light scattering in clouds, causing considerable uncertainty in climate models. The Aerosol Group has participated in several international cloud experiments, and in this way contributed through unique custom-built instruments invented and developed by Bengt Martinsson, and further developed by Göran Frank. It was found that polluted clouds can contain considerably more drops than previously demonstrated, and that clouds with weak dynamics may have low visibility without the formation of thermodynamically activated cloud droplets.



Cloud studies using the droplet aerosol analyser (DAA) on Mt Brocken in Germany, 2010. The DAA set up for field measurements.

Particle properties



Aerosol researchers from Lund were also pioneers in the measurement of particle water uptake through their development of Europe's first H-TDMA (hygroscopicity tandem differential mobility analyser) under the leadership of Hans-Christen Hansson. Within the framework of several international projects, Birgitta Svenningsson and Erik Swietlicki investigated the water uptake of particles during conditions of undersaturation with respect to water vapour (relative humidity of 85% or 90%) and showed, among other things, that this particle property, together with particle size, is important in describing which, and how many, particles act as condensation nuclei for cloud droplets.

During measurements at Great Dun Fell, somewhat below the peak of the mountain ridge, which is visible in the background. In this way, it was possible to characterize the aerosols from which clouds were formed. The photograph shows clouds with bases higher than the peak, but when the peak is swathed in clouds the instruments provide information on cloud properties (see, for example, the DAA in the previous section).



The field station at Vavihill



Already in the 1990s, Erik Swietlicki and his colleagues from the Division of Nuclear Physics realized that there was a need for stations in Sweden to determine the extent to which cross-border particulate compounds affect our health and the climate. Work was begun on a field station at Vavihill on Söderåsen. This station was made permanent in 1999, and is part of a larger European network of monitoring stations (ACTRIS). It has proven to be very important to many researchers across Europe and in global climate studies.



Doubling of particles

An example of the research being carried out at Vavihill is the study by Adam Kristensson, showing that emissions from ships in the Baltic Sea cause a doubling of the number concentration of particles as the air travels over the sea.

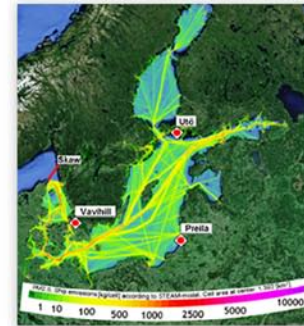
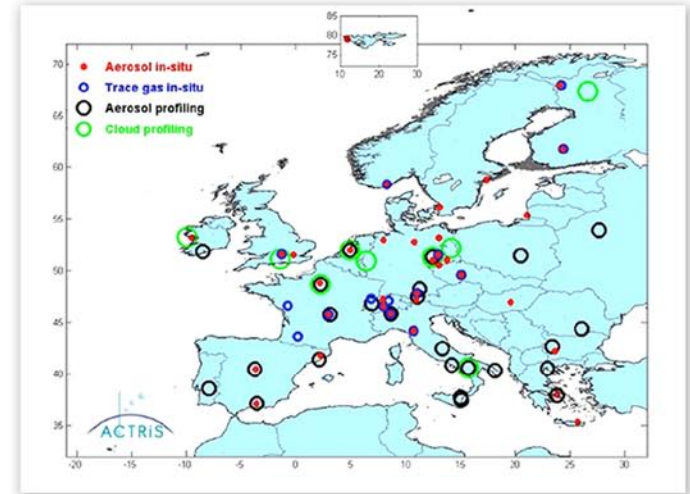

This picture shows the emissions of particulate matter smaller than $2.5 \mu\text{m}$ in diameter along the busiest shipping lanes in the Baltic Sea.



Airborne measurements



Detail from the wing of a Lufthansa Airbus 340-600 used in the IAGOS-CARIBIC project, showing the inlet for air and aerosol particles for atmospheric aerosol sampling.

The Division of Nuclear Physics has been part of the European consortium CARIBIC (now IAGOS-CARIBIC), under the leadership of Bengt Martinsson, since the 1990s. The upper troposphere and lower stratosphere are regularly investigated to map aerosols and trace gases using instruments on board intercontinental passenger aircraft.



Volcanic activity

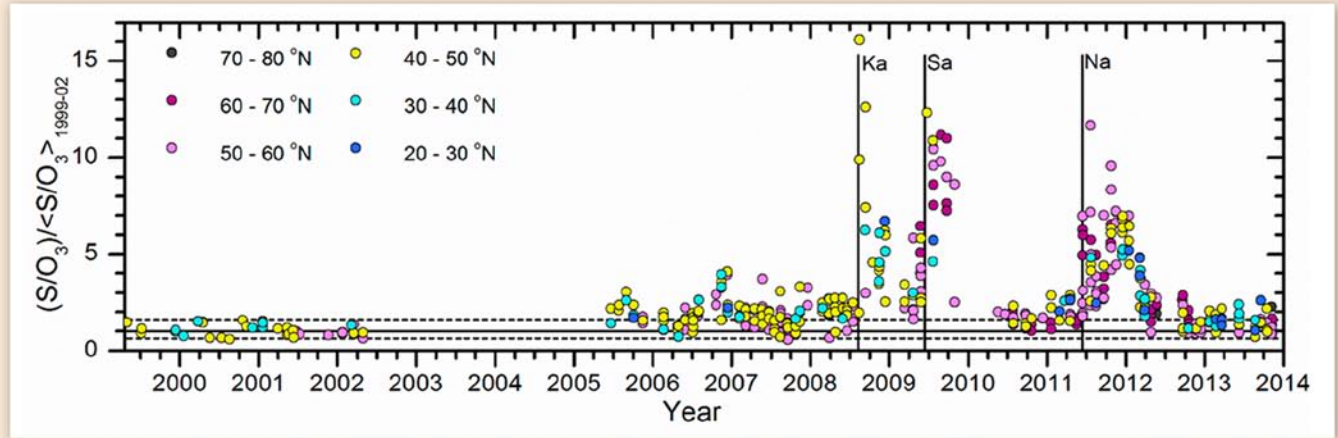

Time series of sulphur (S) concentrations in stratospheric aerosol particles. Volcanism leads to an increase in the ratio of sulphur to ozone (S/O_3) due to an increase in the sulphur concentration. The different colours indicate the latitude range for the measurements. Vertical lines indicate powerful volcanic eruptions: Kasatochi (Ka), Sarychev (Sa) and Nabro (Na).

The Aerosol Group collects samples that are analysed using the accelerator-based methods PIXE and PESA. Their work has resulted in a unique time series of elemental concentrations in aerosols. The results have been used in combination with measurements from the satellites CALIPSO and MODIS to better describe the natural variation in climate associated with volcanic activity.



Particle studies in the Aerosol Lab

In recent years, several studies on soot, cloud droplet formation and simulated atmospheric aging have been carried out at the Aerosol Lab in Lund, which has a very high international standard, and is a joint resource for CAST (Consortium for Aerosol Technology at Lund University). Thanks to the availability of direct-reading instruments, it is possible to carry out detailed studies on, for example, the transformation of soot particles to cloud droplets and particle formation of volatile hydrocarbons from vegetation and human activities.

Conceptual image of a condensation nucleus consisting of an agglomerated soot particle with condensed organic material which has started to take up water to form a cloud droplet. This image forms the basis of the theoretical model developed to describe the experimental results.



The aerosol mass spectrometer used to determine the chemical composition of aerosol particles.

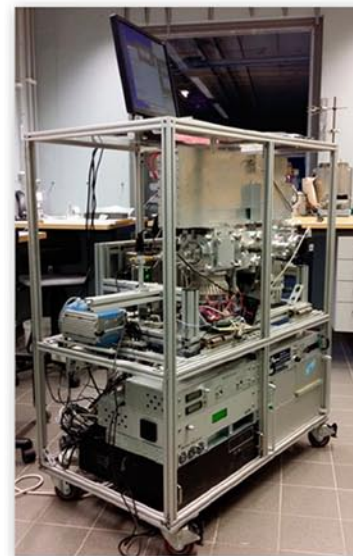

The potential aerosol mass (PAM) reactor used to speed up the aging of gases and particles that takes place naturally through oxidation.





Satellites as tools in aerosol research

Satellite measurements can be used to obtain a global picture of how aerosols affect clouds and the climate. The Aerosol Group's direct measurements on the ground or using aircraft can be compared with satellite remote sensing data. For example, studies have been performed to investigate how the number of particles in the air entering a cloud affects cloud droplet size and the ability of clouds to reflect sunlight back into space. In this way, it is possible to investigate whether air pollution in the form of small aerosol particles actually helps to cool the earth down, and if so, to what extent. Volcanic aerosol particles in the stratosphere can also affect high cirrus clouds and the climate.

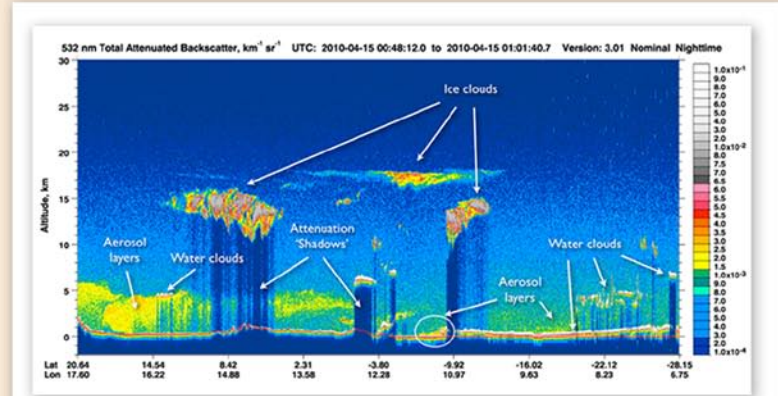

Vertical profile of the atmosphere obtained using lidar (laser radar) on the satellite CALIPSO. Both hot (water) and cold (ice) clouds are formed on the aerosol particles.

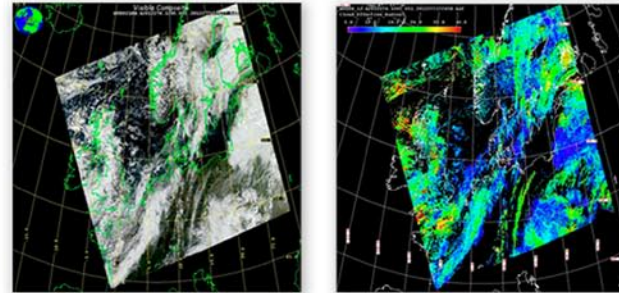

Examples of images of clouds from the satellite-borne instrument MODIS.



Aerosol dynamics modelling

The development of two aerosol dynamics models (ADCHEM and ADCHAM) was started by Pontus Roldin in 2008. ADCHEM is used to model the composition of atmospheric aerosols. It has been used to study, amongst other things, the dispersion of air pollutants from cities such as Copenhagen and Malmö. ADCHAM is used in the design and analysis of aerosol experiments in smog chambers. An important application is the study of secondary organic aerosol formation. Both models contribute to the work within MERGE, a strategic research area on climate modelling.

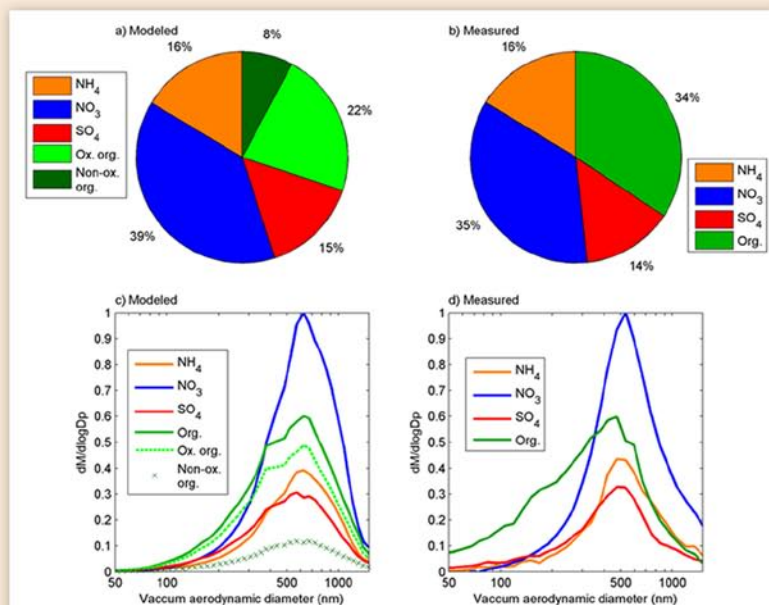

Comparison between the measured (with an aerosol mass spectrometer) and modelled aerosol particle composition at the measuring station Vavihill on Söderåsen, 50 km downwind of Malmö. The modelled organic aerosol composition has been divided into substances that are oxidized in the atmosphere and have then condensed on the existing aerosol particles (denoted Ox. org.), and non-oxidized organic substances emitted as primary particles or that have condensed directly without being oxidized in the atmosphere (Non-ox. org.).



Ein Hertz für das Herz

How one family of physicists repeatedly makes epoch-making discoveries through the generations.

A family of physicists

Hellmuth Hertz was born in Berlin in 1920 to Ellen and Gustav Hertz. Five years later his father was awarded the Nobel Prize for Physics. Heinrich Hertz, who gave his name to the unit of measurement for frequency, was the brother of Hellmuth's grandfather.

Hellmuth would go on to become one of LTH's most successful professors.

Hellmuth Hertz and his son Hans, who has been a Professor of Biomedical Physics at KTH in Stockholm since 1997.

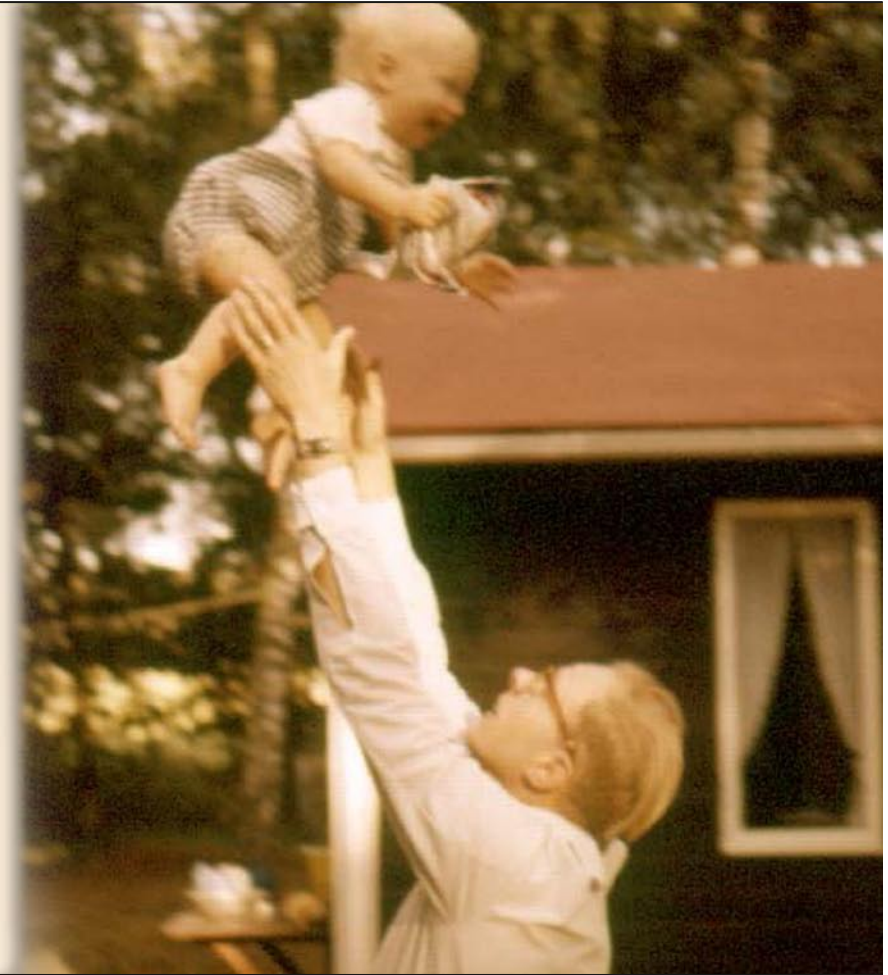

Electromagnetic waves



Heinrich Hertz 1857 - 1894

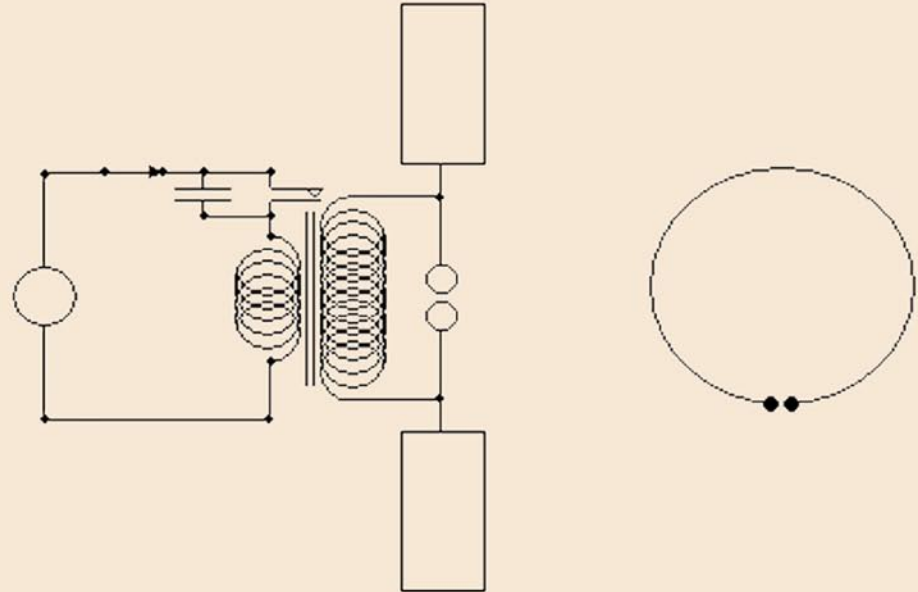

In 1888 Heinrich Hertz was the first to prove the existence of the electromagnetic waves described by Maxwell in 1873.

A spark in the high voltage circuit produces a spark in the ring-shaped receiver. In further experiments, Hertz was able to confirm Maxwell's theory that light is an electromagnetic wave motion.

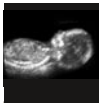

Growing up among physicists

In the early 20th century, German physics research was world-leading, with researchers including Albert Einstein, who like Hellmuth's father was a professor in Berlin.

Einstein received the 1921 Nobel Prize for Physics for the discovery of the photoelectric effect. The theory of relativity was far too controversial to be awarded the prize.

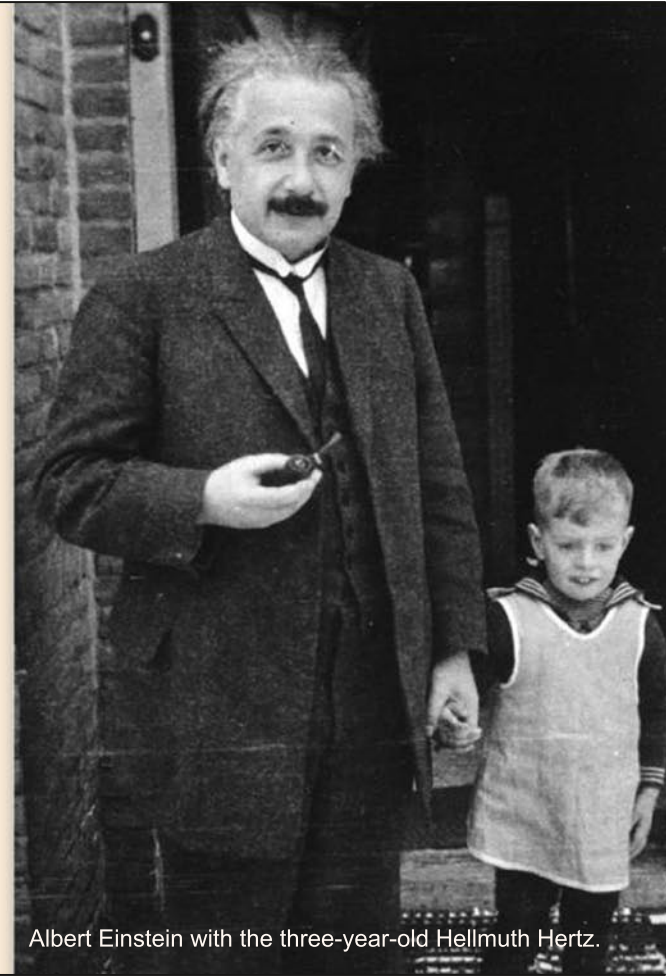

Albert Einstein with the three-year-old Hellmuth Hertz.

The Franck–Hertz experiment



Hellmuth's father, Gustav Hertz, was a professor at the Technische Universität Berlin. In 1935, however, he lost the right to examine students because of the Nazi race laws. He then left his post as professor, but could continue to work as a researcher at the company Siemens & Halske.

At the tender age of 26, Gustav Hertz had carried out an experiment with James Franck that confirmed Niels Bohr's model of the atom. Franck and Hertz received the 1925 Nobel Prize for Physics for their experiment.

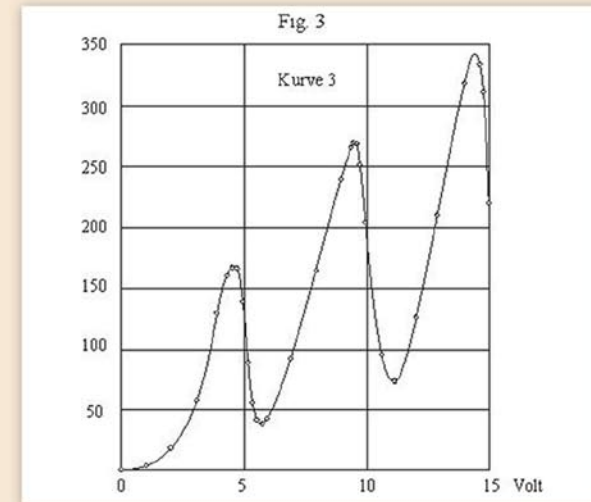

The experiment showed that electrons accelerated through mercury vapour are slowed down when the electrons reach a certain amount of energy, which confirms that an atom can only take up energy in quantised steps.

Studies and war

In 1939 Hellmuth Hertz entered the Technische Universität Berlin, but was forced to interrupt his studies when he was conscripted.

After a short period with the Afrika Korps in North Africa under the leadership of General Erwin Rommel, *the Desert Fox*, he was captured and taken to the USA as a prisoner of war.

Technische Universität Berlin

Almost back home

In the USA, Hellmuth made contact with James Franck, who had shared the Nobel Prize with his father. Franck, who was a Jew, had left his post as professor in Germany when the Nazis came to power in 1933 and, like Einstein and many others, had moved to the USA. Franck was able to negotiate for Hellmuth to continue his physics studies while a prisoner.

When the war ended, Hellmuth returned to Europe and with the help of Niels Bohr in Copenhagen and Torsten Gustafson in Lund he got a job as a teaching assistant at the Department of Physics in Lund.

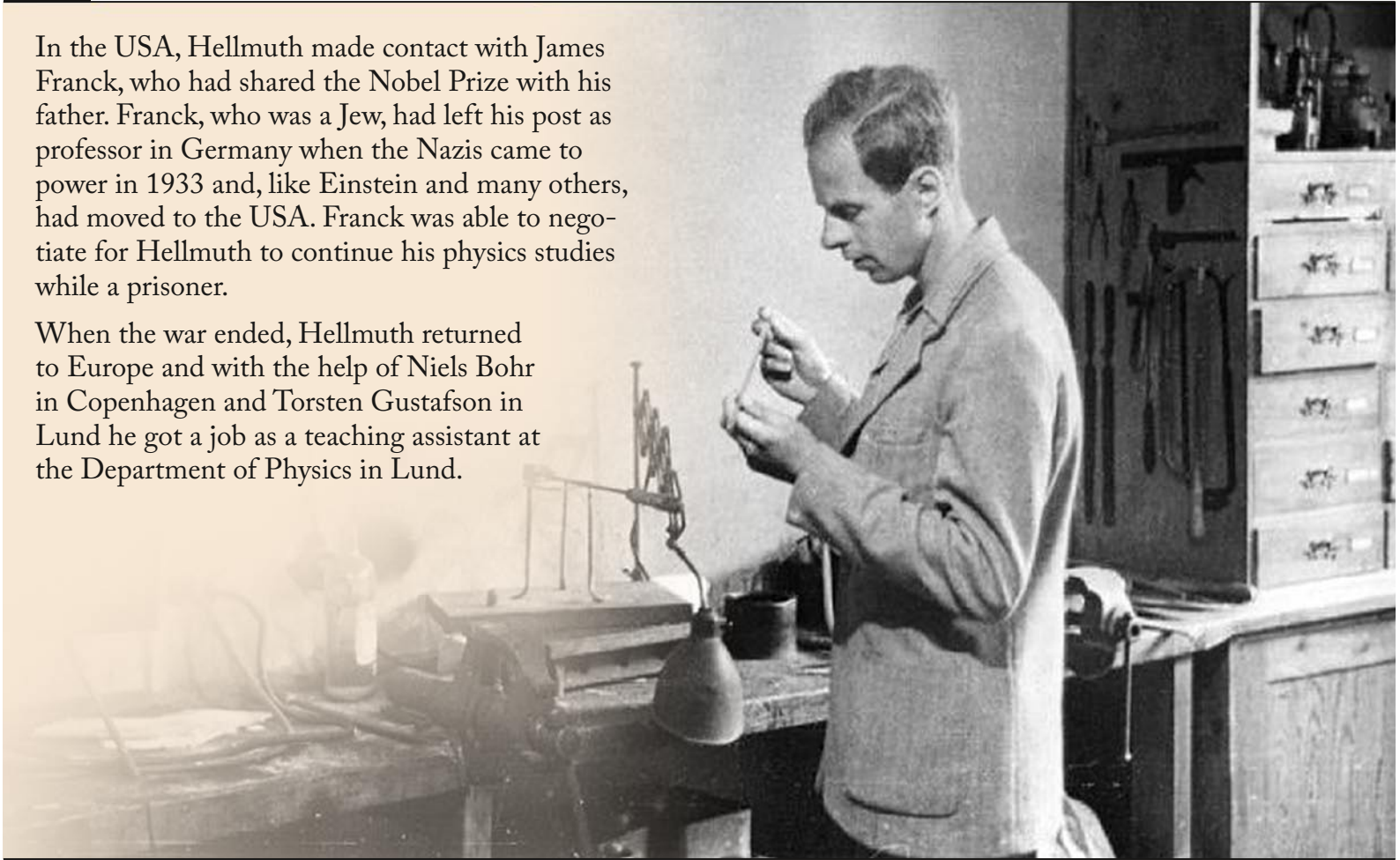



Doctoral student in Lund

As a doctoral student, Hellmuth Hertz led the development of Lund's first accelerator, a 3 MeV van de Graaff generator. There were initially problems reaching the expected voltage and they discovered that this was due to so-called corona discharges in the vacuum tank.

Hellmuth had to find the reason for these discharges. This led to the construction of a high voltage triode. The patent for the triode was sold to the electronics company Philips.

The profits provided the capital for Hellmuth's first car – a light blue VW 1200.

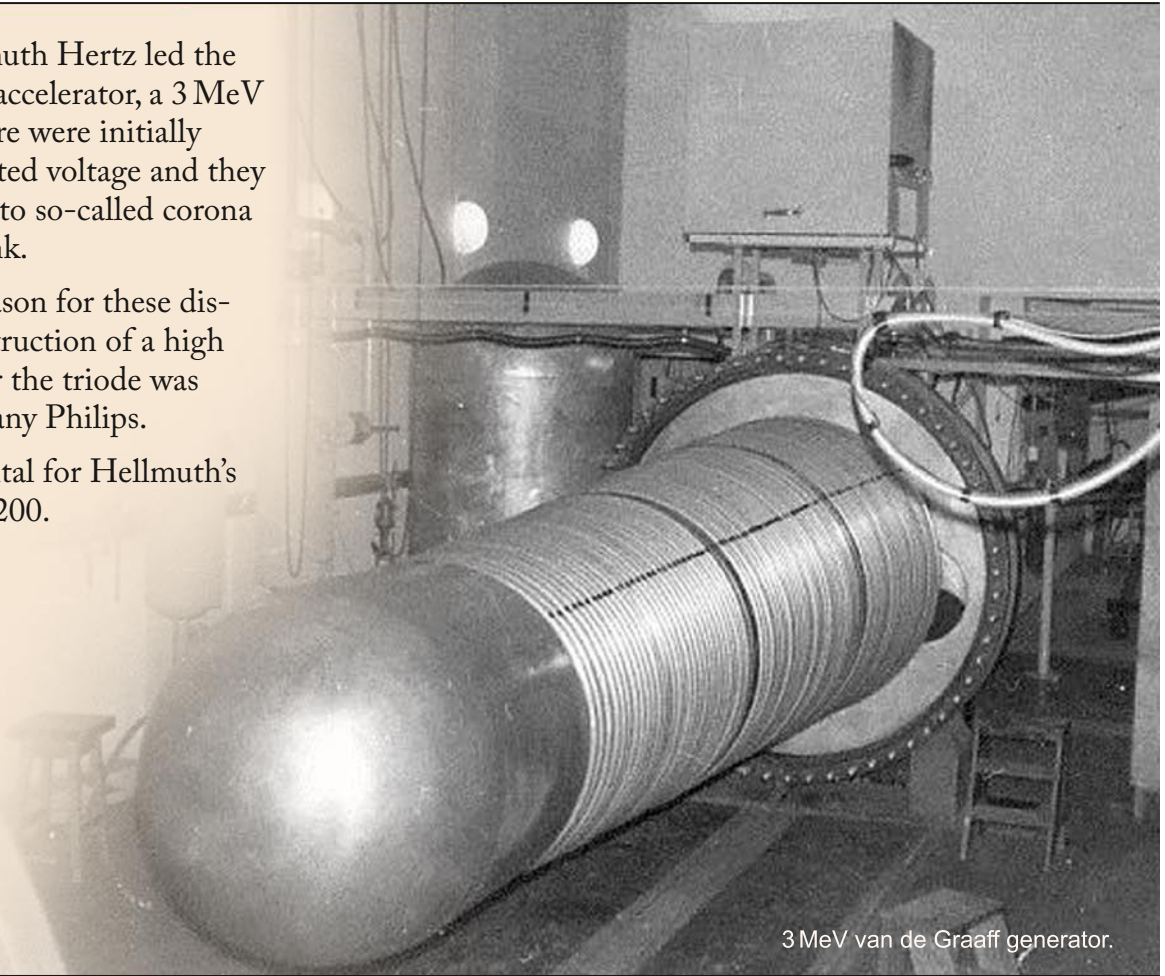

3 MeV van de Graaff generator.

Biophysics

Through Birgit Nordbring, who would go on to become his wife and who at the time worked at the Department of Plant Physiology in Lund, Hellmuth came to understand the need for a quick humidity gauge to study the plants' regulation of transpiration to their surroundings.

Since the conditions for a corona discharge are dependent on humidity, Hellmuth Hertz constructed an instrument called a corona hygrometer. Using this equipment it became possible to study the plants' regulation of their water content.

Thus problems with the atomic physics accelerator had led to a problem in plant physiology being solved.



Birgit Nordbring-Hertz

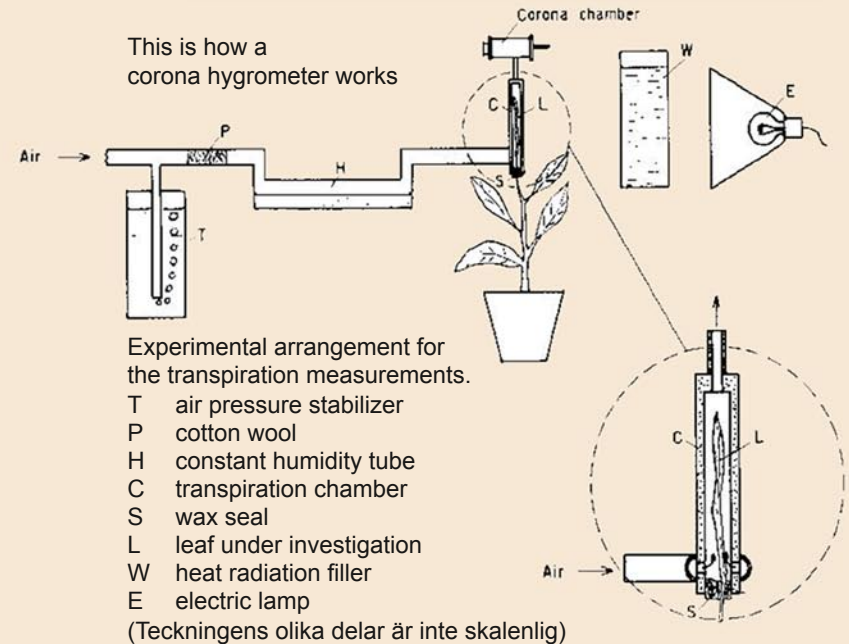



Why does a plant grow upwards?

Another problem, which was drawn to Hellmuth's attention by Hans Burström, Professor of Plant Physiology, was the geoelectric effect of plants.

When a plant or a seed is subjected to gravity, the parts above the earth try to grow upwards and the root downwards. This phenomenon is linked to a low voltage that occurs over i.e. a sunflower stalk, that is laid horizontally.

In connection with his work on the atomic physics accelerator, Hellmuth had developed a non-contact method of measuring the field strength inside the generator.

In order to study the plants' geoelectric effect, he now developed a non-contact electrode to measure field strength of the same type as had been used in the generator.



Ultrasound diagnostics

Cardiologist Inge Edler contacted Hellmuth Hertz in the early 1950's to discuss a method of studying the movements of the heart. Hellmuth suggested they try using ultrasound, which had interested him since his studies in Berlin.

Ultrasound is a wave motion of the same type as normal sound, but with a higher frequency. At the interface between two materials, part of the wave is reflected and an echo can be captured.

Ultrasound technology was used for testing materials, and for his first experiments Hellmuth Hertz borrowed a machine from Kockums shipyard in Malmö.

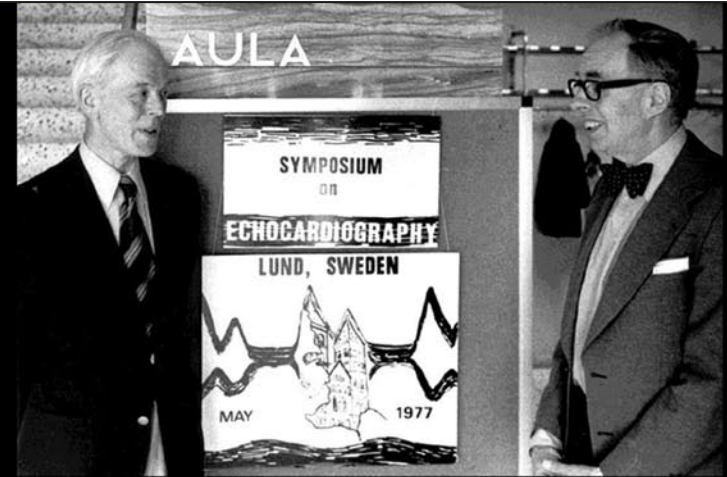

Inge Edler and Hellmuth Hertz.

The first image of the movement of the mitral valve between the left atrium and left ventricle in the heart.

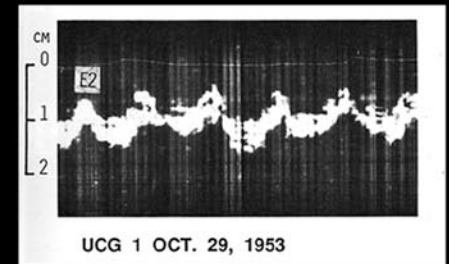



Moving images

As scientific advisor Hellmuth worked with ultrasound for cardiac diagnostics for a year in the mid-1950s at Siemens Medical in Germany.

Back in Lund he continued to develop the methods and manufactured a system of mirrors that could focus the ultrasound and a mechanical system for scanning the whole of the heart.

In this way the first two-dimensional moving images of a living heart in the body, known as an echocardiogram, were produced.

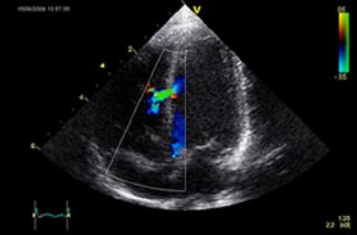

Echocardiogram



Ultra sound image of Emy Nyberg, Uppsala, 2002.

Inkjet printer

In order to print images from ultrasound examinations, a quick high-resolution printer was needed. Hellmuth started out from an existing printer, the mingograph, and in his attempts to modify it Hellmuth Hertz discovered a way to electronically steer a jet of small ink drops.

The method makes it possible to put ink onto paper in a few millionths of a second.

Swedish companies showed little interest in Hellmuth's innovation and he finally sold the patent rights to the USA. The inkjet printer was a Swedish invention that was commercialised abroad.

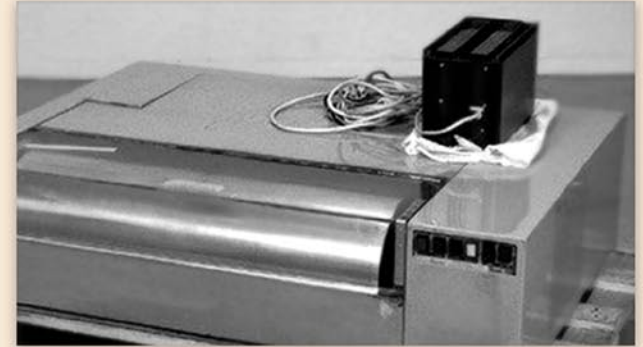

Hellmuth Hertz' inkjet printer. Prototyp. TM40522.



Esteemed professor

In 1963 Hellmuth was appointed Professor of Electrical Measurements at LTH. With his colleagues and doctoral students he continued his research on ultrasound diagnostics, biophysics and inkjet technology.

Artwork produced by artist group Beck & Ljung, commissioned by the Department of Electrical Measurements in tribute to Hellmuth Hertz.

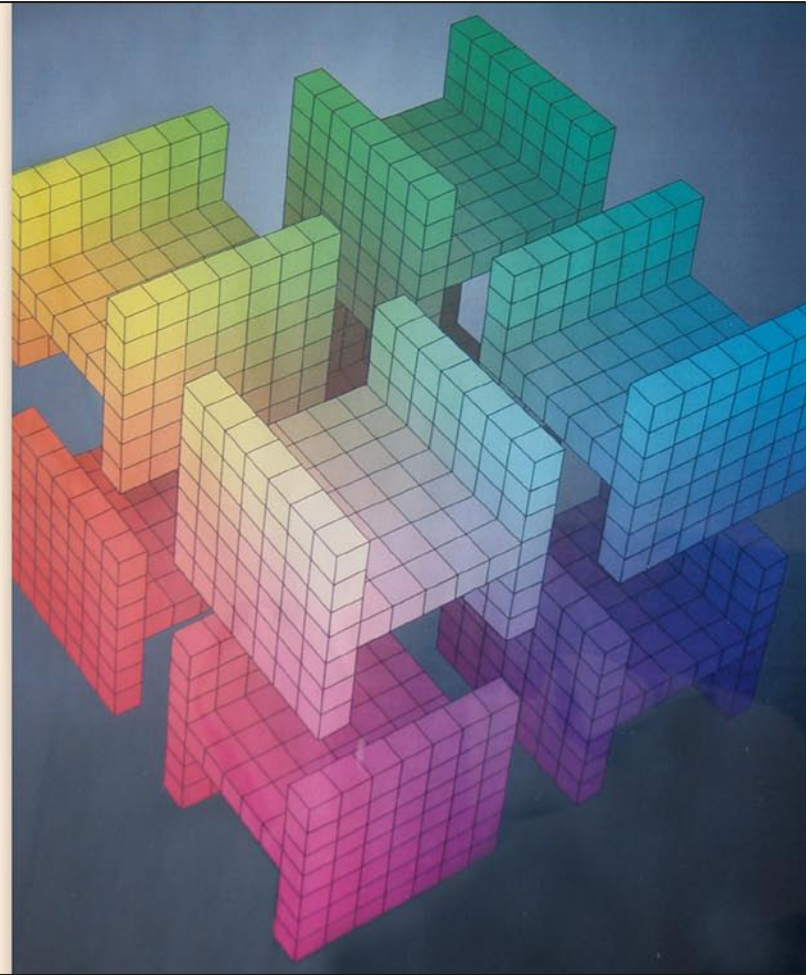

Prizes and awards

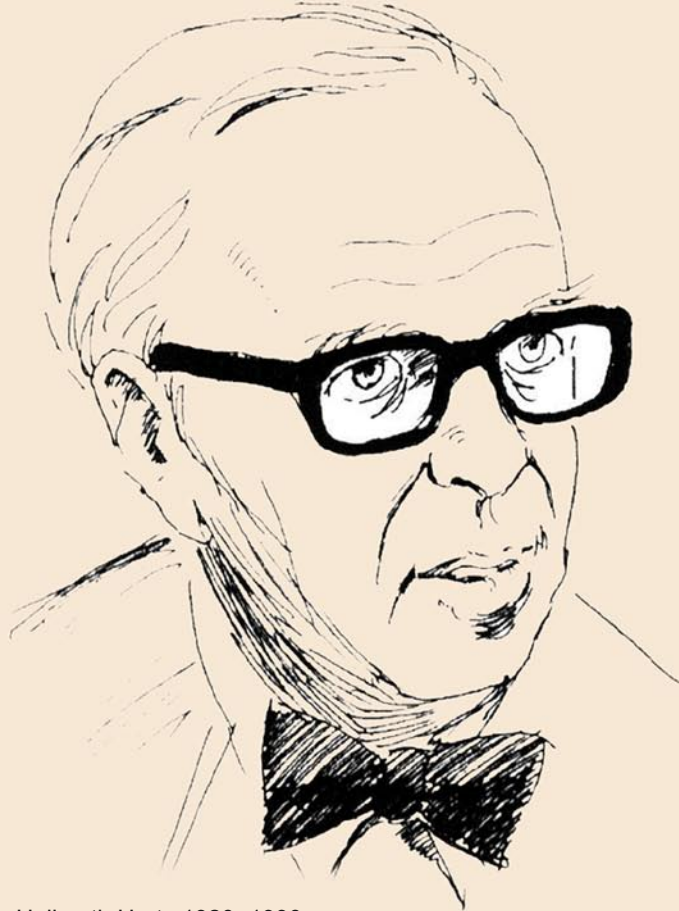

Hellmuth Hertz 1920 - 1990

It is probably unique for a researcher to achieve international success in such widely different fields and during his life Hellmuth Hertz was awarded a large number of international prizes and awards for his research results and inventions.



Lasker Prize

Together with Professor Inge Edler, Hellmuth Hertz received the 1977 Albert Lasker Clinical Research Award, the USA's foremost award in the field of medicine.

Jury statement:

To Dr. Hertz, who brought his extraordinary technical knowledge and imagination from the field of physics to diagnostic medicine, and laid the foundation on which many of today's ultrasound advances have been built, this 1977 Albert Lasker Clinical Medical Research Award is given.



Hellmuth Hertz and Inge Edler.

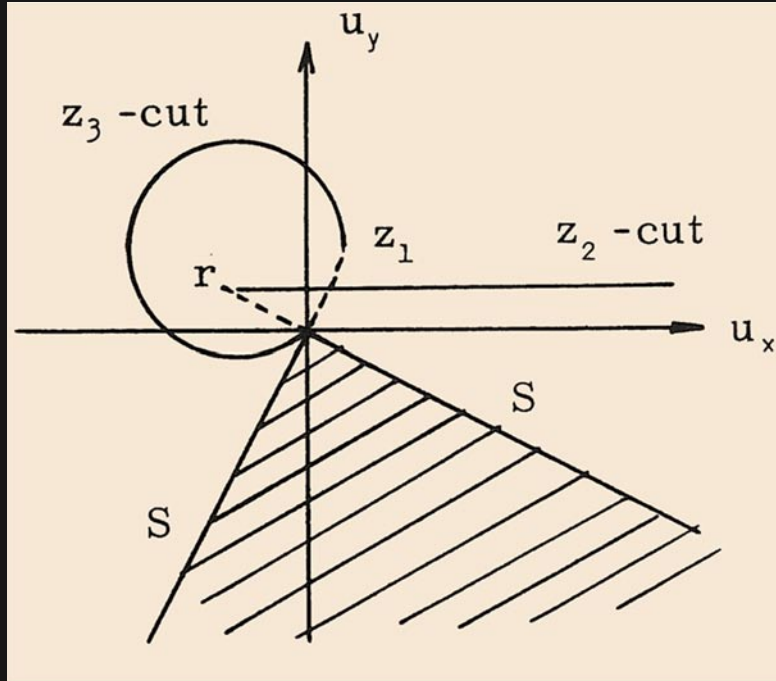

Ekman and Källén

Two world famous
theoreticians from Lund.

The Ekman Spiral

Walfrid Ekman came from Stockholm and studied in Uppsala. He is most well-known for his theories on how the wind, the Earth's rotation and friction in water interact, changing the direction of ocean currents with depth, i.e. the formation of Ekman spirals. The title of his thesis was, *On the Effects of the Earth's Rotation on Wind-Generated Flow at Sea*, and after obtaining his PhD in 1902 he went to work at the Institute of Marine Research in Oslo.

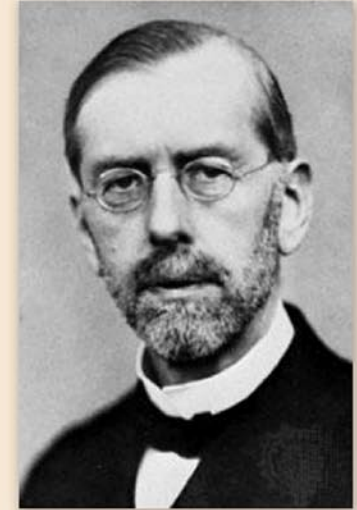

Walfrid Ekman 1874 - 1954
Swedish physicist and oceanographer.

Invisible forces

It was in Oslo that Ekman developed his theory of ocean currents. It had long been known that ships in the northern fjords were sometimes trapped in dead water. It seemed as if the vessels were held by some kind of invisible force – often referred to as *demons of the deep*.

Ekman showed that the phenomenon was due to a lighter layer of fresh water that formed above the sea water at the mouths of rivers and when the ice melted. This led to backwash not only on the surface of the water, but also at the interface between the layers of fresh and salt water, which reduced the speed of the ships.

Simplified illustration of the Ekman Spiral in the northern hemisphere:

Blue – Wind
 Red – Force from above
 Yellow – Coriolis effect
 Pink – Effective direction of the current

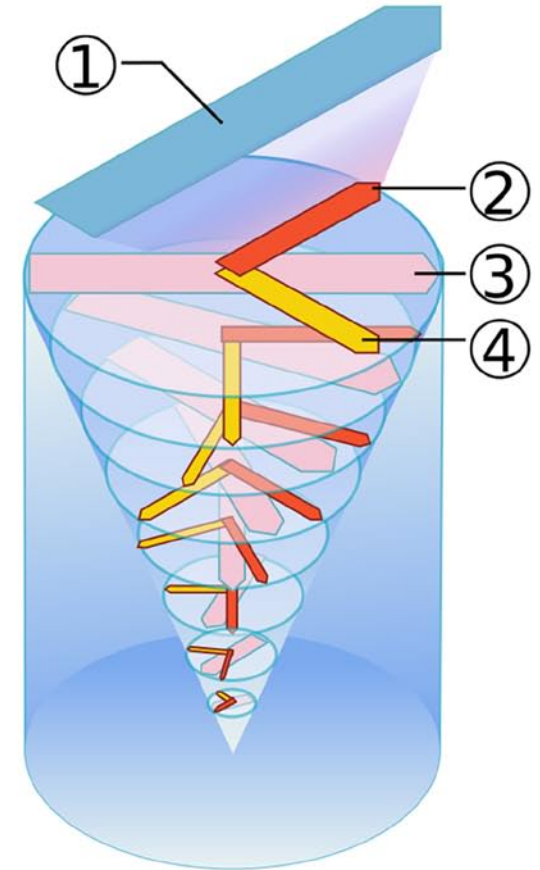

The Ekman Spiral

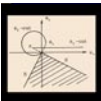

The textbook

Ekman was not only a gifted theoretician, but led many expeditions at sea. He is also known for his textbook in mechanics, from 1919, which was used in physics teaching in Sweden for over 40 years.

Walfrid Ekman became Professor of Mechanics and Mathematical Physics at Lund University in 1910, after Albert Viktor Bäcklund. Ekman was himself succeeded by Torsten Gustafson in 1939.

Walfrid Ekman was known as a serious and deeply religious person, but was also a good singer and pianist.

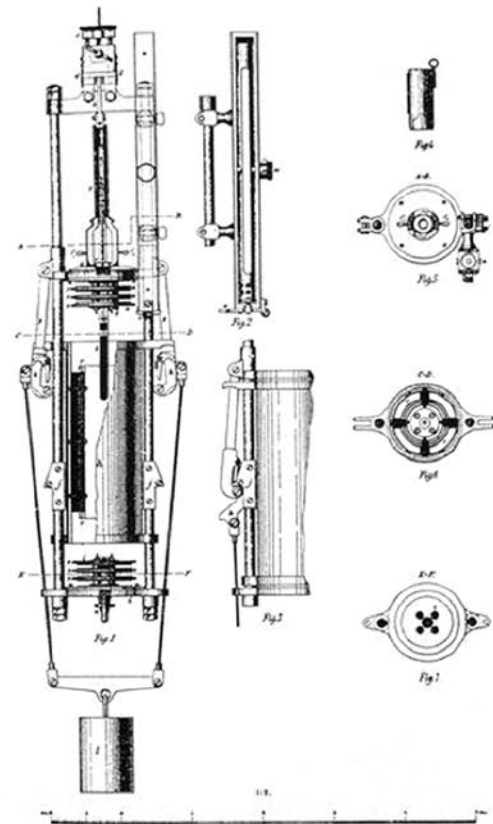

Ekman's design for an ocean current meter.

Theoreticians on the move



The King's House in Lundagård.

The experimental physicists had already moved out of Kungshuset (The King's House) in central Lund in 1846, but the theoreticians remained there together with the mathematicians and statisticians.

It was not until the 1930s that they moved into The Old School Mistress's College on Sölvegatan, opposite what is known today as The Old Department of Physics.

After this, the theoreticians moved to an apartment in the centre of town in Clement's Square, and were finally reunited with their experimental colleagues when the new Department of Physics was inaugurated in May 1951.

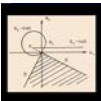

The student and graduate

Gunnar Källén was born in Kristianstad in 1926, but grew up in Gothenburg.

After graduating in 1944, he continued his studies at Chalmers University in Gothenburg, and graduated in Electrical Engineering in 1948.



PhD studies

After graduating in 1948, Källén became a PhD student at the Department of Mechanics and Mathematical Physics in Lund, where Torsten Gustafson was his supervisor.

The following year, Gustafson wrote to the Nobel Prize winner Wolfgang Pauli in Zurich, and asked if it would be possible for *a young man, very interested in theoretical physics* to attend Pauli's lectures during the summer term of 1949.

Källén spent the summer in Zurich, and in July, Pauli wrote to Gustafson, describing Källén as *gifted with considerable skill and talent*.



Pauli, giving one of his lectures, who later referred to Källén as *my discovery*.

Quantum Electrodynamics – QED

Researchers such as Dirac, Pauli, Tomonaga, Schwinger and Feynman developed quantum physics and described the fundamental structure and phenomena of matter.

They were successful in finding the correct expressions (QED) for the interaction between photons and electrons, and created quantum field theory.

With this theory, which allows the creation and annihilation of particles, they were able to describe particles as excitations of fields, and the forces between particles as the exchange of virtual particles. This was visualized with so-called Feynman diagrams.

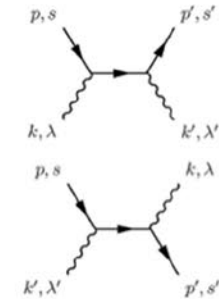

Richard Feynman – QED – and his famous diagrams.

Pauli's advisor

During his first visit to Zurich, Pauli had already suggested to Källén that he study the fourth-order correction of the phenomenon of vacuum polarization in external fields.

Pauli was very impressed with the young man's independence, virtuosity and the speed with which he solved the problem, and his work resulted in a notable publication in *Helvetica Physica Acta* that same year.

Källén and Pauli continued to correspond and Pauli used Källén as his advisor and scrutineer of his scientific publications.

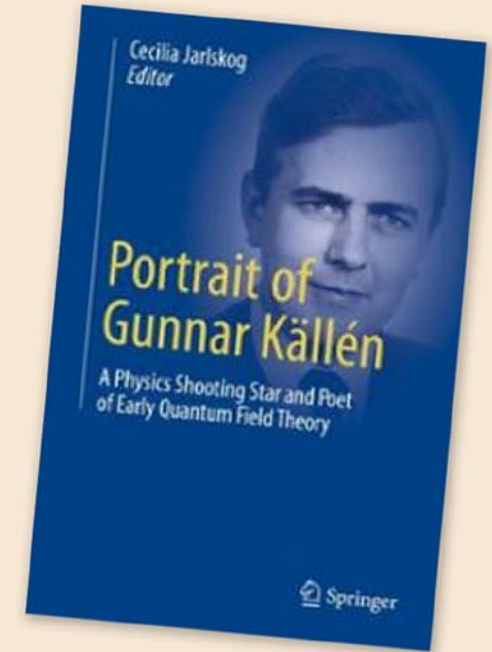

Cecilia Jarlskog, Professor of Theoretical Particle Physics, has written a biography of Gunnar Källén.

Doctor and husband



Gunnel Bojs and Gunnar Källén.

Källén continued his studies in QED in Lund, and obtained his doctorate in 1950. The title of his thesis was, *Formal Integration of the Equations of Quantum Theory in the Heisenberg Representation*.

The following year he married Gunnel Bojs, and in 1952 he became the first researcher to be employed at the newly established CERN Theoretical Study Division in Copenhagen.

The poetry of physics

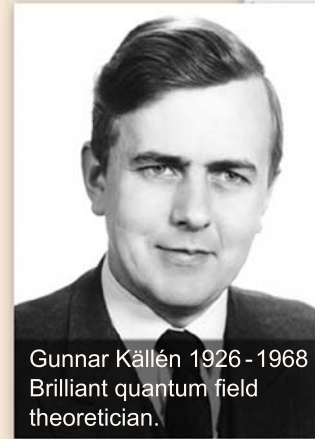

Gunnar Källén 1926 - 1968
Brilliant quantum field
theoretician.

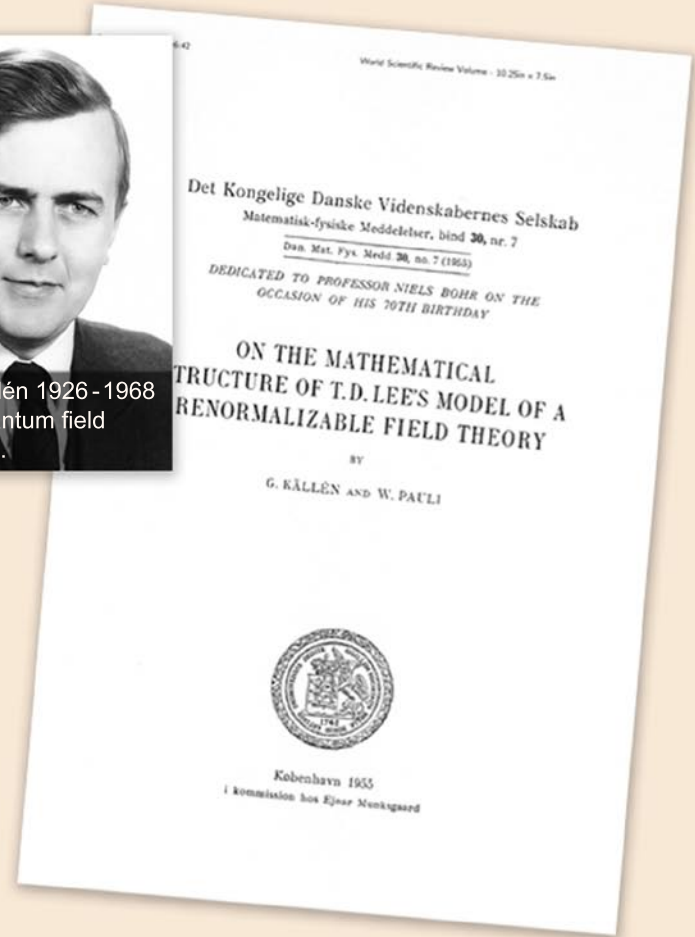

One of the most important questions at that time was whether QED, with its divergent integrals giving infinite answers and renormalization techniques, was a consistent theory.

Källén studied these problems in an original way by using the Heisenberg representation, and obtained new results beyond interference theory.

Källén's impressive results placed him firmly in the quantum field theory *Hall of Fame*. It was said that he wrote poetry using the complex language of quantum field theory, while others could barely understand the grammar.

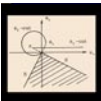

The forces of nature

During the later part of the 1950s Källén broadened his research to include formal aspects of quantum field theory.

Together with his colleagues and PhD students he studied the general properties of vacuum expectation values of the products of field operators. It was hoped that this would lead to theories describing the forces of nature.

Källén discovered elegant relations and equations, but was nonetheless disappointed that his efforts did not lead to the new physical knowledge he had expected.



The 12th Solvay Conference of 1961 dealt with quantum field theory.

Theoretical particle physics

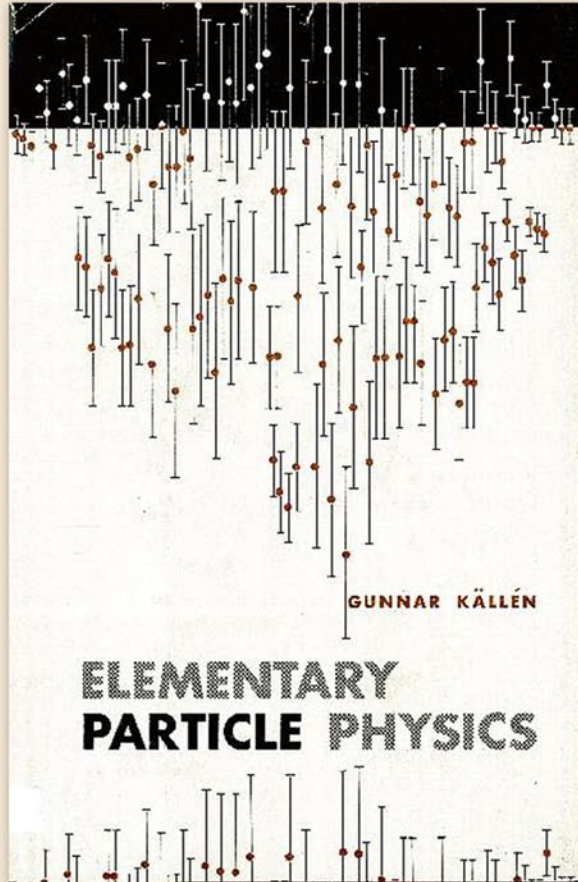

Källén's final field of research was theoretical elementary particle physics. He learnt the subject quickly by giving lectures, and wrote a much-admired book, *Elementary Particle Physics*, which was published in 1964.

His final articles dealt with higher order corrections in muon and beta decay.

Källén is also known for other work in quantum field theory: The Källén–Sabry potentials and the Källén–Lehmann representation.

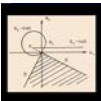

Personal Professorship

In 1958, Gunnar Källén was awarded a personal professorship in theoretical physics.

Gunnar Källén was much appreciated by his students, both as a supervisor and lecturer.

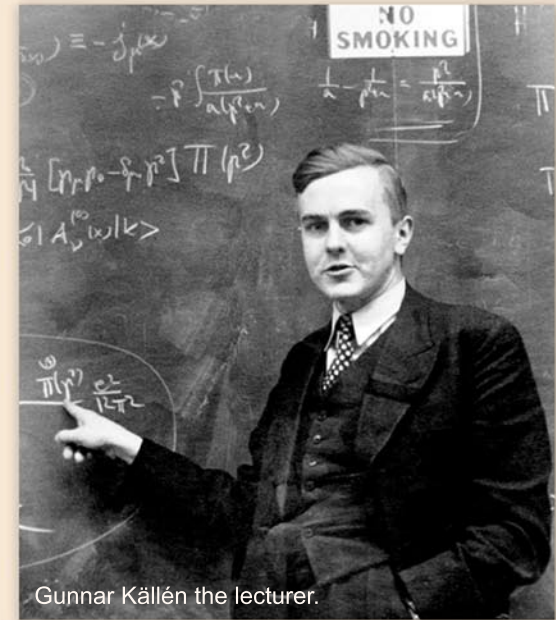

Gunnar Källén the lecturer.

A sudden departure

Gunnar Källén had been interested in flying since he had been a child. In 1964 he started taking flying lessons in Malmö. On 13th October 1968 Gunnar Källén took off from Bulltofta Airfield in Malmö to attend a meeting at CERN. In the plane with him were his wife and her friend, Matilda von Dardel. They had planned to land on the way in Hannover, but 10 km short of Hannover the plane developed engine problems. In an attempt to make an emergency landing, the plane hit a tree and crashed. Gunnar Källén died a few hours later, while the other passengers were only slightly injured.



The Gunnar Källén lectures

January 5, 2012 16:42 World Scientific Review Volume - 10.25in x 7.5in 15

Nr. 6

Fig. 1. The curve (31) for the case $y_1 > 0$; $y_2 > 0$; $x_1 y_1 + x_2 y_2 > 0$.

Fig. 2. The curve (31) for the case $y_1 > 0$; $y_2 > 0$; $x_1 y_1 + x_2 y_2 < 0$.

$$r = \frac{(x_1 + q^2) y_2 + (x_2 + q^2) y_1}{y_2 - y_1 - y_2} > 0, \quad (32a)$$

$$x_2 - x_1 + x_2 - 2qq' + \frac{(x_1 + q^2) y_2 + (x_2 + q^2) y_1}{y_2 - y_1 - y_2} + \frac{(x_1 + q^2)(x_2 + q^2) - y_1 y_2}{x_1 y_2 + x_2 y_1 + q^2 y_2 + q^2 y_1} (y_2 - y_1 - y_2). \quad (32b)$$

If we call $x_2^{(0)}$ the value of x_2 which we get from (32b), by putting $q^2 - q'^2 = qq' = 0$, the difference between x_2 and $x_2^{(0)}$ can be written in the following way

To prove the gauge invariance (supposing the integrals in (61) to converge) we need an identity of the same type as equation (27). We have

$$\begin{aligned} & \bar{P}_{p_{r_1}, \dots, p_{r_n}}^{(n)} (p p' \dots p^n) (p_{r_1} - p_{r_2}) = (p'^2 - p^2) \times \\ & \times [\pi_{1,1}^{(n)} - \sum \delta_{v_1, v_{i-1}} (p'^2 + m^2) \pi_{1,1, i-1}^{(n)} + \dots] - (p^2 + m^2) \times \\ & \times (p'_2 - p_2) [\pi_{1,2}^{(n)} - \sum \delta_{v_1, v_{i-1}} (p'^2 + m^2) \pi_{1,2, i-1}^{(n)} + \dots] - \\ & - (p^2 + m^2) (p'_2 - p_2) [\pi_{1,2}^{(n)} - \sum \delta_{v_1, v_{i-1}} (p'^2 + m^2) \times \\ & \times \pi_{1,2, i, i-1}^{(n)} + \dots] = (p^2 + m^2) \bar{P}_{p_{r_1}, \dots, p_{r_n}}^{(n-1)} (p p' \dots p^n) - \\ & - (p^2 - m^2) \bar{P}_{p_{r_1}, \dots, p_{r_n}}^{(n-1)} (p' p' \dots p^n). \quad (64) \end{aligned}$$

We can now repeat the calculation from equation (29) to equation (35) but start from (61) instead of (25) and use (64) instead of (27). The result is obviously that, from this formal point of view, (61) is gauge invariant.

Regular lectures or symposia have been held in Lund since 1972 to honour the memory of Gunnar Källén. Among the 60 or so lecturers to date is the Nobel Prize winner Steven Weinberg, who delivered a lecture entitled *Living with Infinities*. Weinberg paid a moving tribute to Gunnar Källén, saying that he regarded himself as one of Källén's disciples.



Sven Gösta Nilsson and his Model

One of the most successful theoretical models of the atom ever developed, and the man responsible.

The man behind the model



Sven Gösta Nilsson was born in Kristianstad in 1927. After graduating from high school in Helsingborg, he continued his education at the Royal Institute of Technology (KTH) in Stockholm, where he obtained a degree in Engineering Physics in 1950. During the course of his studies he spent a year in Pasadena, USA, where he obtained a BA.

Sven Gösta Nilsson was very successful in his studies at KTH, but a career as an engineer didn't appeal to him, so he changed direction.

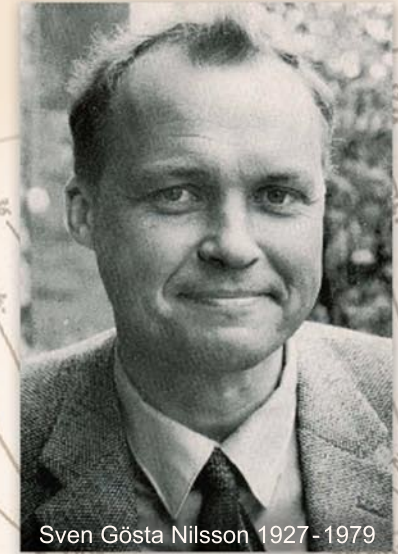

Lund – Copenhagen



In 1950 Sven Gösta Nilsson was accepted as a post-graduate at the Department of Mechanics and Mathematical Physics in Lund, where Torsten Gustafson became his supervisor. His research involved calculations of atomic structure, which led him to work closely with researchers at the Niels Bohr Institute in Copenhagen.

The first real theories on the structure of the atom had been developed in 1911-1913, and consisted of a thin cloud of electrons surrounding a small dense nucleus. These theories were based on Ernest Rutherford's experiments in Manchester, and on Niels Bohr's model of the atom.



Ernest Rutherford 1871 - 1937



The Niels Bohr Institute in Copenhagen.



The structure of the atom

In 1932 Ernest James Chadwick showed that the nucleus consisted of protons (hydrogen nuclei) and the hitherto unknown neutrons. As the neutron was not charged it could easily react with charged atomic nuclei to create new, heavier nuclei.

However, bombarding uranium with neutrons gave surprising results that were difficult to interpret. No new, heavier elements were made; instead, moderately heavy elements were detected. The chemists Otto Hahn and Fritz Strassmann in Berlin found barium ($Z=56$) among the reaction products.



James Chadwick
1891 - 1974



An atomic nucleus is characterized by the number of protons, Z , and the number of neutrons, N . The name of the element is determined by the number of protons. For example, the heaviest naturally occurring element is uranium, which has 92 protons, i.e. $Z=92$.

Like a drop of water?

The explanation came in 1938, when the physicists Lise Meitner and Otto Robert Frisch understood that the neutron split the uranium atom into two fragments. If the nucleus was regarded as being a drop of liquid, it could be understood how the neutron caused self-oscillation of the uranium nucleus.

When the oscillations became too large, the nucleus broke up. As the two fragments were lighter than the original nucleus, energy was also released, according to Einstein's famous equation: $E = mc^2$ where m = mass, and c = the velocity of light.

The process was called fission.

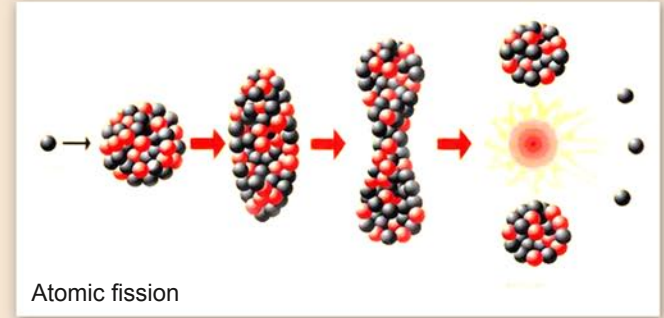

Or a spherical shell?

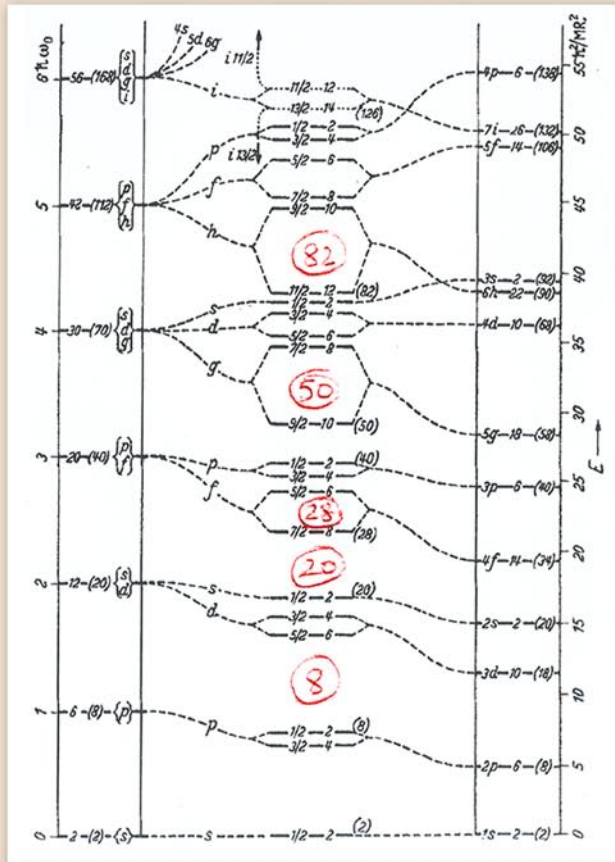

Calculated single-particle levels shown in an original figure by Jensen and his colleagues from 1950, where the *magic numbers* have been inserted by hand (in red).



Maria Goeppert-Mayer in USA and J Hans D Jensen in Germany were awarded the Nobel Prize in 1963 for their independent explanations, in 1949, of these magic numbers; namely that the nucleons move in stable shells in the nucleus. Their angular momentum, l , and their spin, s , were coupled, giving a $l \cdot s$ term.

At the same time as the discovery of the neutron, it had been suggested that the atomic nucleus had a shell structure similar to the electron shells. The reason for this was that certain numbers of protons or neutrons, called *magic numbers*: 2, 8, 20, 50, 82, 126 etc., led to especially stable nuclei.

Or cigars and discs?



In Copenhagen, Niels Bohr's son, Aage Bohr, and his American colleague Ben Mottelson (Nobel Prize 1976), extended the calculations to prolate (disc-like) and oblate (cigar-like) nuclei. Experiments had indicated that nuclei far from those with magic numbers were easily deformed.

Many of their colleagues shook their heads in disbelief when they heard of the attempts of researchers in Copenhagen to combine individual orbits with the collective behaviour in atomic nuclei.

This is where Sven Gösta Nilsson enters into the picture.

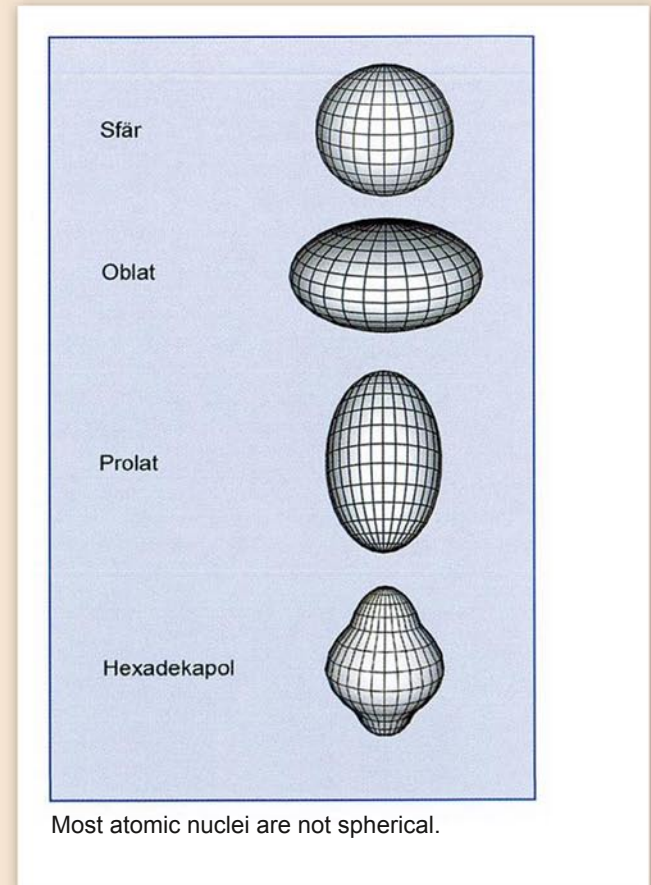

A bestseller!

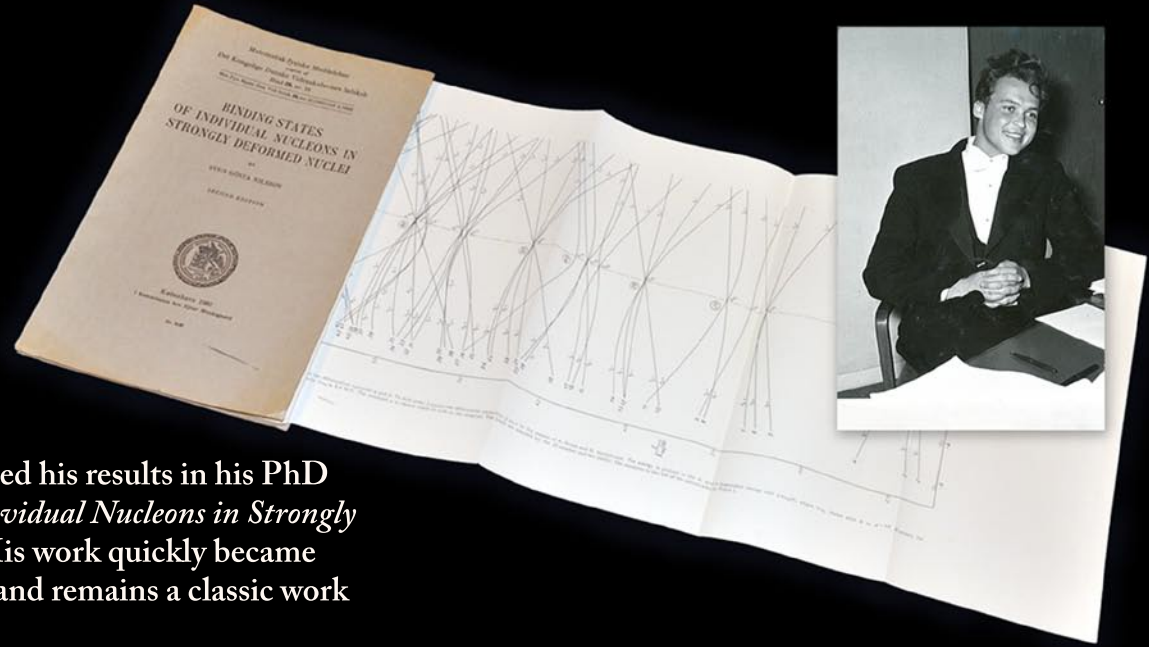

Sven Gösta Nilsson presented his results in his PhD thesis, *Binding States of Individual Nucleons in Strongly Deformed Nuclei*, in 1955. His work quickly became internationally recognised, and remains a classic work in the field.

...This is the one paper one finds on the desk of every nuclear physicist...

according to Victor Weisskopf, Professor at MIT and Director General of CERN, during his extensive talk at the international conference on the structure of the nucleus in 1960 in Kingston, Canada.

A photograph of Sven Gösta Nilsson's PhD thesis showing the pull-out on which his calculations for single-particle levels are shown as a function of nuclear deformation – the first Nilsson diagram.



Computations and experiments



Leading nuclear structure researchers in the 1970s
– Aage Bohr, Sven Gösta Nilsson and Ben Mottelson.

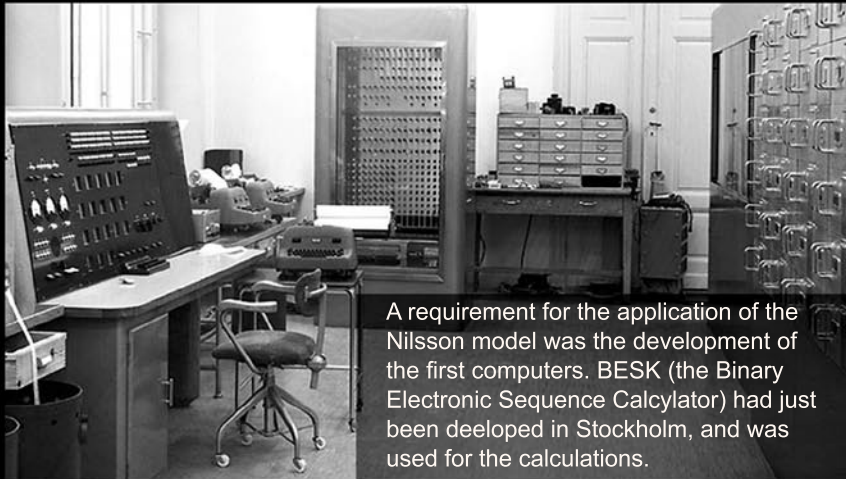

A requirement for the application of the Nilsson model was the development of the first computers. BESK (the Binary Electronic Sequence Calculator) had just been developed in Stockholm, and was used for the calculations.

During the following years, Sven Gösta, mainly together with Ben Mottelson, made comparisons with experimental results.

They found that the model described the nuclear spin, rotational state and magnetic moment with amazing accuracy.

When the agreement with observations was not good, it was often found that the calculations were correct and the experimental results in error!

Nuclear spectroscopy

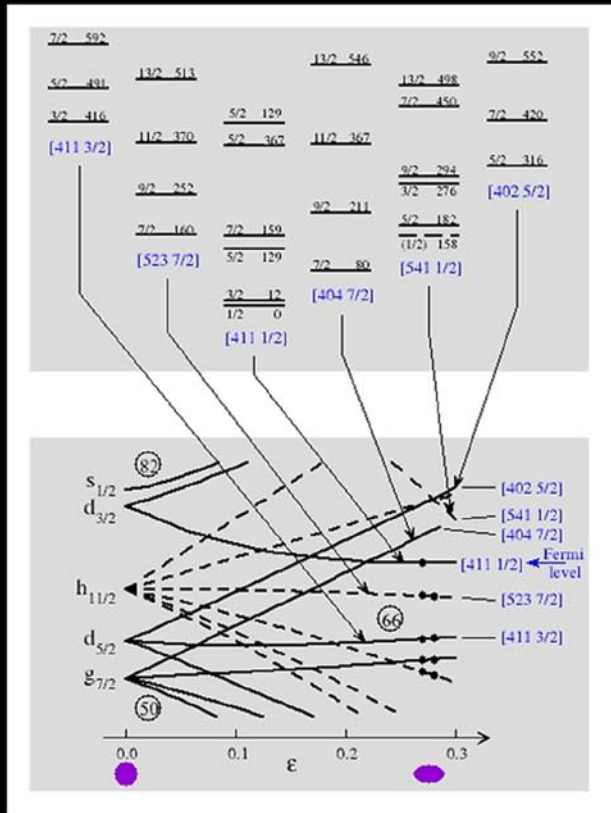

The lower figure shows the Nilsson diagram for $Z = 50-82$. In the deformed nuclei, the axis of symmetry is about 30% longer than the orthogonal axis, with corresponding values of $\epsilon = 0.25-0.30$.

The upper figure shows the rotational band observed in the nucleus ^{165}Tm , which has 69 protons. The lowest rotational band is obtained if the protons are placed according to the filled circles in the Nilsson diagram, with the odd proton in the Fermi level $[411 1/2]$. The excited bands are obtained by exciting the odd proton into a higher level, or by creating a vacancy in a level below the Fermi level.

Nuclear fission

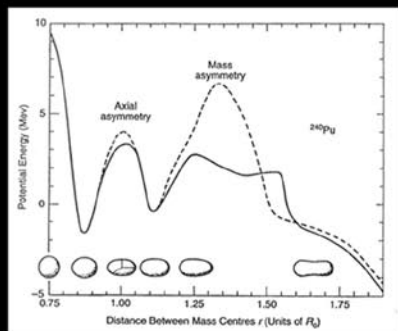

A diagram and ceramic model, by Lisa Larsson, showing the variation in the potential energy of the atom in the process leading to fission, illustrating that fission is easier if the two fragments have different masses.



In 1963, Sven Gösta Nilsson was appointed Professor in Mathematical Physics at LTH. He assembled a large group of students who used his model in many applications.

They combined the Nilsson potential with the liquid drop model and started serious studies on the process of nuclear fission.

They were able to make detailed calculations of the process, which led to the understanding of why the two products had different masses. The pattern followed that previously suggested in calculations by Sven A E Johansson, Professor of Experimental Physics in Lund.

Superheavy elements



The tool developed by Sven Gösta Nilsson's group also made it possible to study the properties of very heavy elements with $Z > 92$, the transuranics, which do not occur naturally.

According to the Nilsson model, $Z = 114$ should be the next magic number, and a nucleus with 114 protons and 184 neutrons should be extremely stable and thus observable.

They predicted an island of relatively stable nuclei in the region around $Z = 114$, $N = 184$.

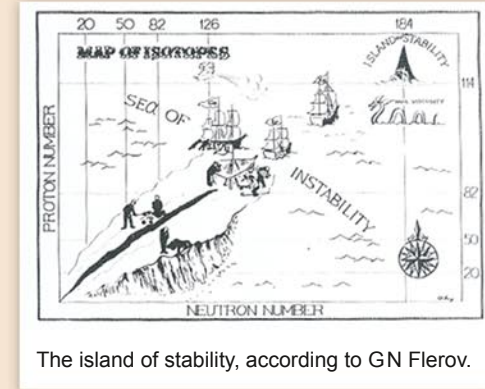

The island of stability, according to GN Flerov.

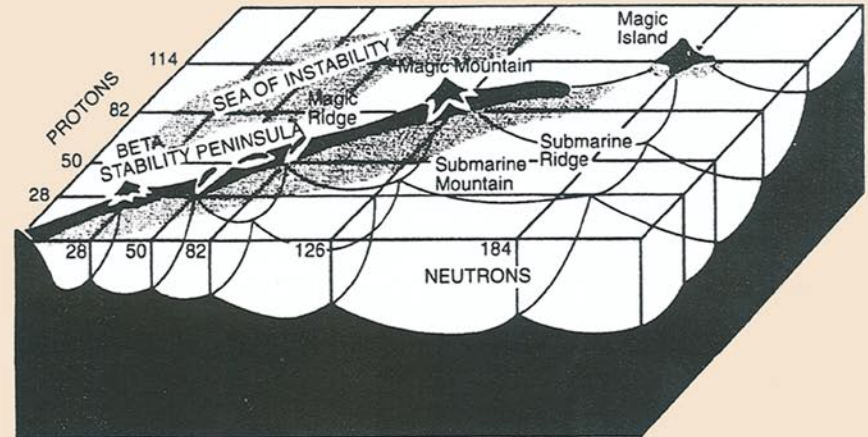

A peninsula of stable nuclei and the predicted island of superheavy nuclei.



The hunt for the Island of Stability

It was not until the 1990s that it became possible to make heavy nuclei in the region approaching the island of stability using heavy ions. Today, it is believed that the island is really a large peninsula with relatively stable nuclei in the region $Z=114-126$ and $N=178-184$.

During the 2010s the experimental nuclear structure group in Lund has become one of the main actors in the hunt for this peninsula, by determining the number of protons using X-rays.

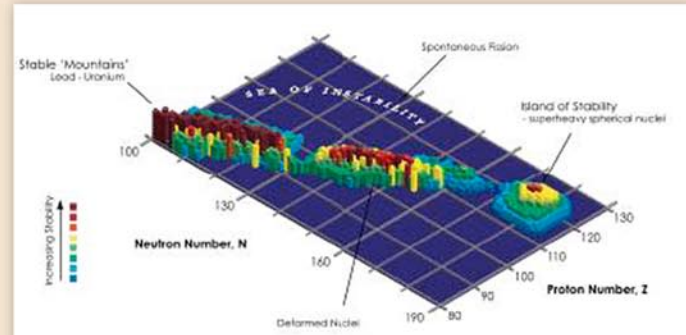

A three-dimensional image showing the theoretical peninsula of more stable nuclei around $Z=114-126$ and $N=178-184$ (from 2011).

Rapidly rotating nuclei

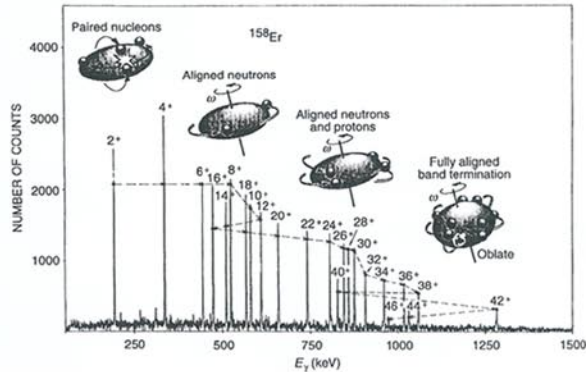

Energies of γ -rays emitted when excited rapidly rotating nuclei decay, with illustrations showing how the angular momentum is developed in different phases.

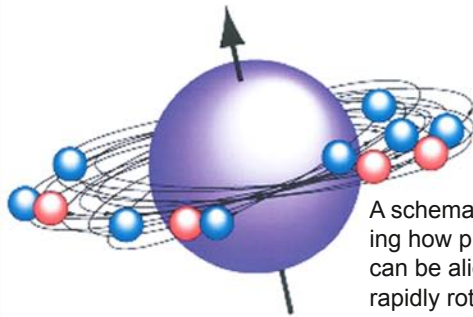

A schematic illustration showing how protons and neutrons can be aligned in a *plane* in a rapidly rotating nucleus.

At the beginning of the 1970s it became possible to study increasingly rapidly rotating nuclei up to the limit set by the centrifugal force at which the nucleus breaks apart.

The first indications that the properties of nuclei changed when they rotated were observed in 1972 by Hans Ryde's group at the Manne Siegbahn Institute in Stockholm.

Sven Gösta now devoted himself and his group to collaboration with Aage Bohr and Ben Motelson in Copenhagen. The phenomena discovered in rapidly rotating nuclei could be predicted and explained with the Nilsson model.



Nilsson's research group

Sven Gösta built up an enthusiastic research group, and Lund became an important centre for theoretical nuclear structure research. He created a familiar and creative atmosphere, and showed great interest not only in his PhD students, but also their families.

Nuclear physicists from around the world were anxious to discuss research with him. Lund continued to be an internationally leading centre for research into theoretical nuclear models after his untimely death in 1972.



Sven Gösta Nilsson together with members of his research group at the beginning of the 1970s.

Standing from the left:

Gunnar Ohlén, Christer Gustafsson, Ingemar Ragnarsson, Stig Erik Larsson, Reginald Boleu, Johan Claesson, and Petr Janeček.

Sitting:

Sven Bertil Nilsson, Peter Möller, Zdzisław Szymánski, Sven Gösta Nilsson, and Thomas Johansson.

A social conscience

Sven Gösta was also very interested in philosophy, literature and religion, and he took part in many public debates, not least through the Swedish press. His articles in a number of Swedish daily newspapers covered a broad range of topics.

He was deeply concerned about the limited resources on Earth, the environment and energy, and he exemplified the interaction between various factors by designing a board game about energy together with his son Bengt. The game was produced by Alga, and was commercially available for a number of years.



Sven Gösta together with his wife Ingrid and children Bengt and David.

During the 1960s and 1970s Sven Gösta Nilsson wrote a large number of articles on a wide range of subjects, which were published in Swedish newspapers.

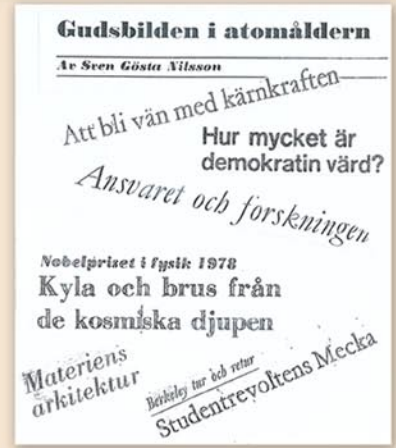

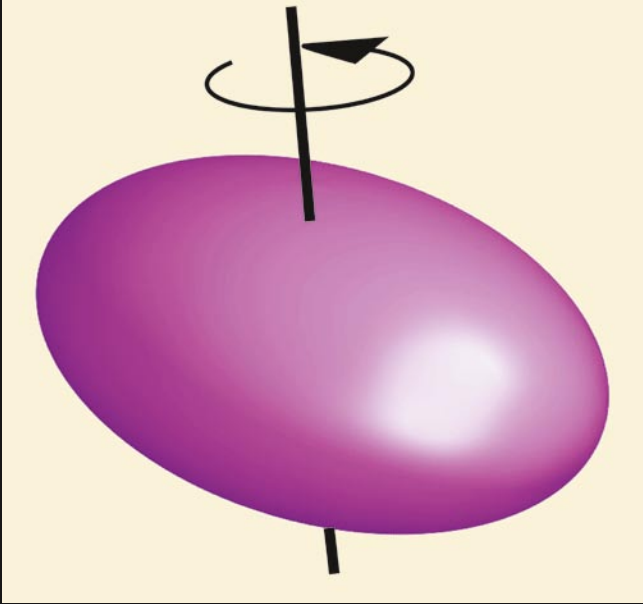

Symmetry in the world of atomic nuclei

The properties of atomic nuclei
and the existence of
superheavy nuclei.



Atomic nuclei shake, rattle and roll!

By the time of his death in 1979, Sven Gösta Nilsson had established an active research group working on rapidly rotating nuclei. The spirit within the group is illustrated by the words of Sven Åberg.

Every Friday morning during the autumn of 1974, the mathematical physics group took the ferry from Malmö to Copenhagen to take part in Ben Mottelson's weekly course on the latest findings in high-spin nuclei. This was always followed by extensive discussions, including Aage Bohr, Ikuko Hamamoto and Ben himself. We prepared ourselves for these discussions on the way over on the ferry, and our table was always covered with sheets of paper with long calculations. Mottelson's lectures seemed easy to understand until we took the ferry back to Malmö and tried to analyse what he had actually said in detail.





The lady from Japan

Ikuko Hamamoto came to the Niels Bohr Institutet in Copenhagen in the 1960s thanks to a stipend from Japan. When the Professorship in Mathematical Physics in Lund became vacant in 1979, due to the death of Sven Gösta Nilsson, Hamamoto was appointed to the position in the face of fierce international competition.

Hamamoto was to spend over 40 years working in Copenhagen and Lund. A few years after retiring, she returned to Tokyo, where she is still very active in theoretical nuclear research.



Ikuko Hamamoto, Professor in Mathematical Physics at Lund University between 1982 and 2001.



Wobbling modes

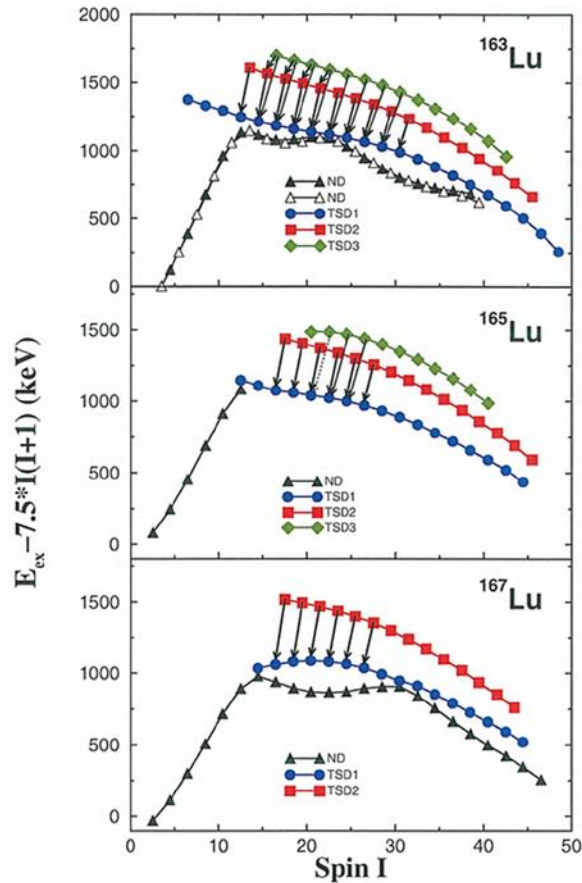

Ikuko Hamamoto has been interested in understanding and interpreting nuclear physical phenomena with a focus on particle-vibrational coupling in nuclei in order to obtain knowledge on the collective and single-particle motion in the nucleus.

In the search for triaxial nuclear shape she made basic predictions as to the features of electromagnetic transitions characterizing triaxial shape and suggested and pinned down that the experimental finding by G B Hagemann et al. in 2001 is the discovery of wobbling mode.



An expert in the calculation of nuclear masses



Peter Möller is now an American citizen, working at Los Alamos National Laboratory in New Mexico.

Peter Möller continued Sven Gösta Nilsson's calculations on fission, and is today a leading expert in the field. Through meticulous research he has developed a detailed model for the calculation of nuclear masses.

It is of great importance to be able to predict nuclear masses, for example, in order to understand astrophysical processes, and to be able to make predictions of the limit on the size of nuclei.

Möller's mass equation has long been the most reliable in the study of so-called superheavy elements.



Predictions of new elements

Elements heavier than uranium do not exist naturally on Earth in measurable quantities as they are unstable, and decay radioactively to lighter elements. However, it is possible using modern mass equations to predict so-called islands of stable superheavy nuclei.

Some superheavy elements can be created by the collision and fusion of other lighter elements in accelerators, and in recent years about 20 new elements have been added to the periodic table.

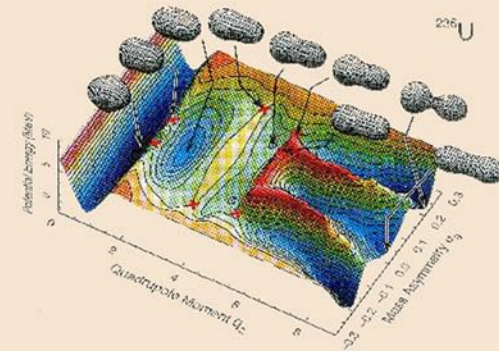
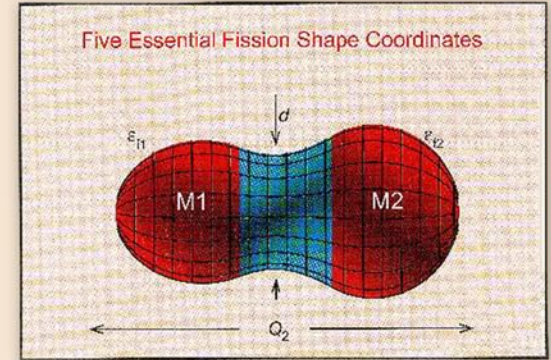

A map showing the shape of the uranium nucleus changes as it passes over the energy landscape consisting of peaks and valleys.



Captured by rotating nuclei

What happens to a nucleus when it rotates very rapidly? How do the protons and neutrons in the nucleus behave? How fast can it rotate before it breaks up?

Ingemar Ragnarsson is studying how the interior of the nucleus behaves and, through his research, has increased our understanding of how various quantum mechanical effects give rise to different nuclear shapes.

As the frequency of rotation increases, the rotation of the nucleus can suddenly cease, and the rotational motion is restricted to a relatively small number of nucleons. This is called band termination. Ragnarsson has developed a formalism that makes it possible to understand and predict this phenomenon.



Ingemar Ragnarsson, Professor of Mathematical Physics.



Band termination

Ingemar Ragnarsson collaborates with experimental nuclear physicists, as this allows him to test his theoretical calculations of the detailed behaviour of nuclei, and to develop new models that can subsequently be used in his colleagues' experiments.

Apart from descriptions of band termination, Ingemar has also studied the structure of strongly deformed nuclei, so-called super-deformed nuclei. Together with Sven Gösta Nilsson he has written an important book on nuclear structure physics, called *Shapes and Shells in Nuclear Structure*.

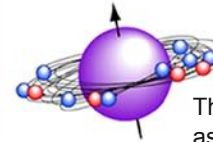
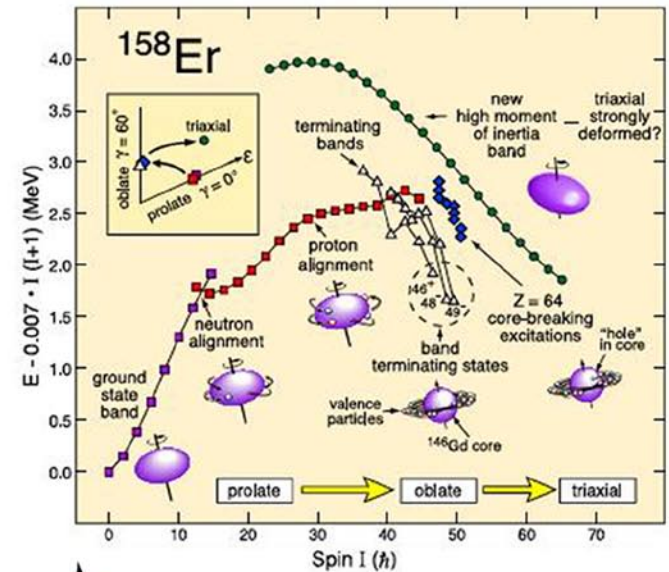

The nucleus of ^{158}Er exhibits different shapes as the frequency of rotation (spin) increases (x-axis) with increasing spin, the shape changes from prolate (like a cigar) to oblate (like a pancake), and finally becomes triaxial (the three axes are different). When the shape of the nucleus is oblate, terminated band behaviour is seen, where the energy of the system (y-axis) varies irregularly.



Close encounters of the experimental kind!

Ragnar Bengtsson has devoted most of his research to the description of rotating nuclei. His most famous contribution to the field is the Bengtsson-Frauendorf formalism, which was developed at the end of the 1970s. Transforming the observed energy spectra into the rotating system allows a simple, general comparison with theoretical energy levels.

Bengtsson has long been involved in collaboration with international experimental groups in the quest to understand and describe experimentally observed energy spectra. These studies have led to an improved understanding of co-existing nuclear shapes and triaxial nuclei.

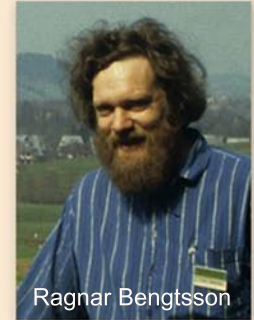

Ragnar Bengtsson

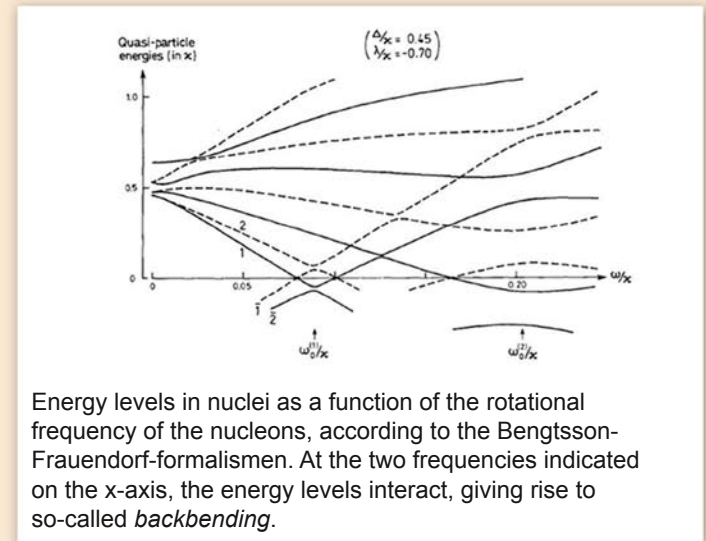



Researcher and organizer



Sven Åberg was director of the Division of Mathematical Physics between 2000-2016 and the President of the Royal Physiographic Society of Lund 2011.

First as a PhD student in the 1970s, and later as a researcher in the 1980s, Sven Åberg devoted much of his time to rapidly rotating nuclei, and contributed to our understanding of how rotation can cause superdeformation. The results were important for the experimental discovery of superdeformation in 1986.

Åberg also studied how exotic nuclei can be de-excited by emitting alpha particles or protons; a field that is currently of great interest.



Initiator

Sven Åberg has also contributed to our understanding of central problems in nuclear structure physics, such as when nuclei become chaotic and the consequences of such phenomena.

He has introduced a condition for how quantum chaos enters a general many-particle system, sometimes referred to as the Åberg condition.

Other areas where he has made important contributions is pairing, level density, giant resonances and ultra-cold atomic quantum gases.



Sven has also taken the initiative for several summer schools for nuclear physics (together with Ben Mottelson) and has organized several international conferences on nuclear- and chaos physics. He has founded and run the Gemstone project at LTH, and NORDITA's Master Class in Physics. Projects aimed at talented High School Students in Sweden and PhD Students in the Nordic countries.

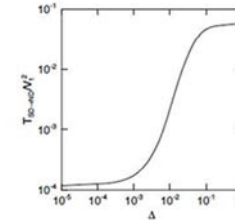

Chaos-assisted tunneling from a super-deformed state to a normal deformed. The picture shows how the probability of tunneling (vertical axis) increases very dramatically if account is taken of the chaotic properties of the nucleus (horizontal axis). The mechanism involves that a superdeformed state can decay rapidly in accordance with experimental results.



Theoreticians in a spin!

Stig Erik Larsson took part in the development of the formalism and wrote a considerable part of the computer program used to describe triaxial rotating nuclei.

Georg Leander made crucial contributions in the field of pear-shaped nuclei and their rotation. Despite his youth, he had a leading role as a theoretician at Oak Ridge National Laboratory in the USA, before his untimely death as a result of cancer in 1989.

Tord Bengtsson, who started his PhD studies in 1979, soon revealed a talent for developing formalisms and writing computer programs. His program for describing energy levels and rotational bands in rapidly rotating nuclei is still used around the world today.



Stig Erik Larsson



Georg Leander



Tord Bengtsson



Success with open quantum systems

Tore Berggren obtained his PhD in Lund in 1966 for his work on the interpretation of the results of $(p,2p)$ -experiments performed at the Gustav Werner Institute in Uppsala. His interpretation supported the shell model for nuclei.

In the 1960s he developed theories on resonant states in open quantum systems, where the particles were almost unbound and could leave the system.

In an important publication in 1967 he showed how such unbound states could be treated mathematically.

Tore Berggren was a reader in mathematical physics at LTH 1966 - 1996.



Tore Berggren 1931 - 1996



A Sleeping beauty

Many scientific papers include Tore Berggren's name in their title.

In 2007, a conference was held in Trento in northern Italy, to celebrate the 40th anniversary of Tore Berggren's important findings: *40 years of the Berggren representation*.

His findings have recently also proved useful in calculations on the nanoscale in experiments on quantum dots.

Tore suffered from a rheumatic disease, and died in 1996, only 64 years old. Unfortunately, he did not live to see the important international breakthrough of his theoretical work.

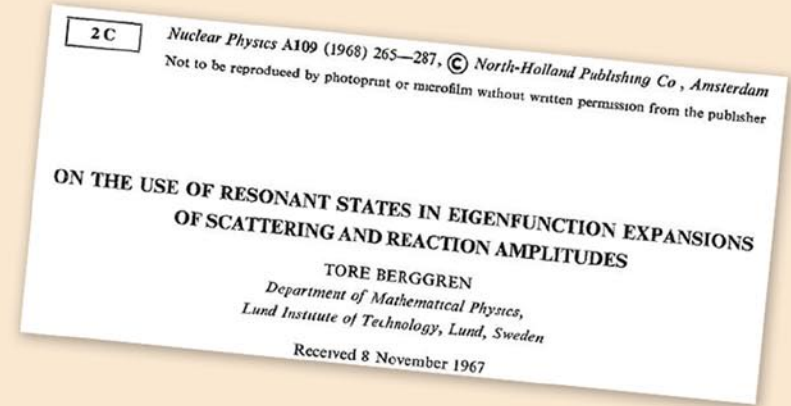

Tore Berggren's ground-breaking work from 1967. It was found much later that his theories from the 1960s could be used to describe the structure of unstable nuclei by combining them with the shell model. His work paved the way for the formulation of an extensive many-particle theory for open quantum systems.



Alpha-particle-like states in the nucleus

Gillis Carlsson obtained his PhD in 2007 for his theoretical work on rotating atomic nuclei, with Ingemar Ragnarsson as supervisor.

His greatest interest lay in understanding the properties of nuclei based on the forces acting between nucleons. This is very difficult, and an important part of his work was thus devoted to finding approximations for the description of the motion of the nucleons in the nucleus.

In order to describe alpha-decay, he considers how two protons and two neutrons close to the surface of the nucleus bind to form an α -particle that then has a small probability of tunnelling its way out of the nucleus.

Note the extremely good agreement between the experimental data and theory. There is only one operating parameter in the calculations.

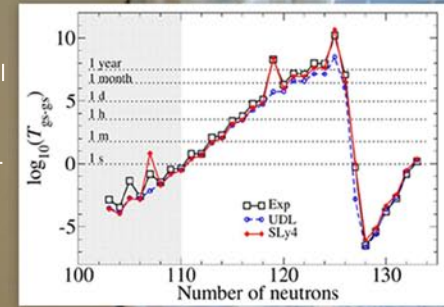

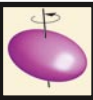

An acclaimed speaker

Cecilia Jarlskog obtained her PhD in theoretical physics Lund in 1970, and was the first woman to obtain a doctoral degree in this subject at Lund University. In 1994 she returned from CERN to Lund as Professor of Theoretical Particle Physics at the Lund Institute of Technology (LTH).

Below an extract from the speech by J V Luce in July 2005 when Cecilia was awarded an honorary doctorate at Trinity College in Dublin in 2005.

She has skilfully and mathematically investigated the principles on which the sub-atomic and electronic constituents of matter cohere, or lose their symmetry. As a result of long-continued and penetrating research in this field she is in a position to discourse authoritatively on the formation and emergence of the physical world, and on the rationale of the observed properties of its smallest constituents.



Cecilia Jarlskog is also an accomplished and much sought-after speaker.

Quarks

⊗

Leptons

EXIST

any number of families
in the Standard Model

- $S_u = M_u M_u^\dagger$
- $S_d = M_d M_d^\dagger$

$|V_{\alpha j}|^2 = \text{tr}(P_\alpha(S_u) P_j(S_d))$

$\alpha = u, c, t, \dots$
 $j = d, s, b, \dots$

Happy



The Jarlskog invariant

Cecilia Jarlskog has mainly devoted her time to research on the theory of the weak nuclear force, and she is most well known for having developed the Jarlskog invariant. This is an invariant quantity in particle physics associated with CP violation, it is the part of the interaction that differs between particles and antiparticles. She showed that this quantity is independent of the arbitrary phases required by quantum mechanics in the wavefunctions of quarks.

Jarlskog has also been involved in communicating the results of research to society as a whole and, amongst other positions, she has served as advisor to the Director General of CERN.

CP violation

$$\Delta P(\alpha, \beta) = P_{\nu_\alpha \rightarrow \nu_\beta} - P_{\bar{\nu}_\alpha \rightarrow \bar{\nu}_\beta} = 4 \times \sum_{i>j} \text{Im} [U_{\alpha i}^* U_{\beta i} U_{\alpha j} U_{\beta j}^*] \sin \left(\frac{\Delta m_{ij}^2}{2E} L \right)$$

$$\text{Im} [U_{\alpha i}^* U_{\beta i} U_{\alpha j} U_{\beta j}^*] = (\pm) J_{CP}$$

Jarlskog invariant

(+) cyclic permutations in (α, β) and (i, j)
 (-) anticyclic permutations in (α, β) and (i, j)

Independent of the mixing matrix parameterization = rephasing invariant



Physics in Lund gets a boost, or two!

How a Vice-chancellor charms Malmö politicians and secures an institute of technology in Lund, and how a new type of spectroscopy is introduced.

Sweden needs more engineers!

Around the middle of the 1950s, both politicians and industrialists realised that Sweden required more engineers to ensure industrial expansion in the coming decades. Thanks to the baby boom of the 1940s, many teenagers were heading towards higher education.

A working party at the Ministry of Education and Science proposed that the number of students at the Royal Institute of Technology (KTH) in Stockholm and Chalmers Institute of Technology (CTH) in Gothenburg be considerably increased.

But what about Scania?



The Royal Institute of Technology (KTH) in Stockholm.



Chalmers Institute of Technology (CTH) in Gothenburg.

Not in Stockholm or in Gothenburg ...



The Kockums Shipyard

The Scanian Engineers' Club, SIK, were quick off the mark. They had observed that students from Scania (Skåne, the southernmost province of Sweden) who had studied at KTH or CTH often returned home to look for employment. Also, relatively few students from Scania studied engineering – clearly because there were no such programmes available in Scania.

A small but active group, including representatives from SIK, Lund University and the borough of education in Malmö, lobbied for the establishment of higher education in engineering in Scania.



Important industries in Scania
The Scanian Cement Works,
later to become Skanska.

... and not in Malmö either!



Philip Sandblom

Vice-chancellor of
Lund University 1957-1968.

Until 1958, the plan was to locate the new Scanian institute of technology in Malmö, but attention was turned towards Lund, in large thanks to the arguments presented by Professor Philip Sandblom, then the Vice-chancellor of Lund University. He pointed out that, as well as the teaching staff, Lund University had a strong tradition in subjects that would be of importance for a new institute of technology, such as physics, mathematics, and chemistry.

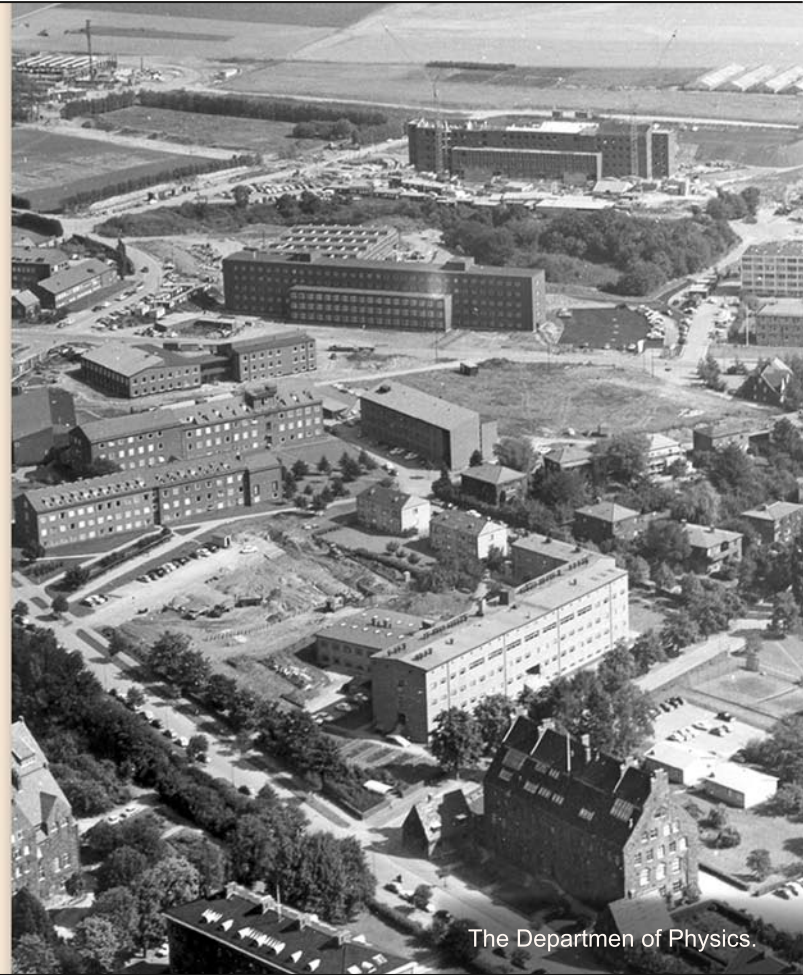

The Department of Physics.

A succinct but significant study

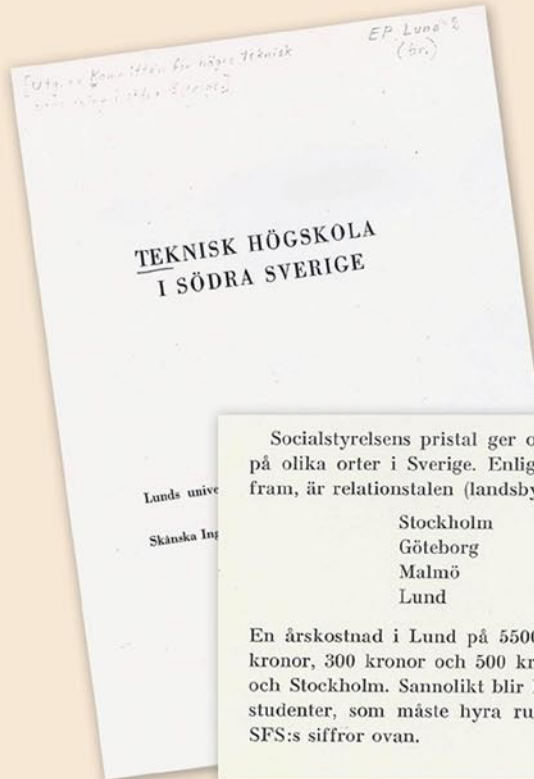

A small committee, including Professor Sandblom, the physicists Sten von Friesen and Krister Kristiansson, the mathematician Åke Pleijel, and the two chemists Erik Larsson and Gösta Ehrenswärd, wasted no time in completing their study to assess the possibility of teaching engineering subjects in Lund. The report from their study was completed in April 1959, and courses in engineering physics were started in Lund just two years later, in 1961.

An Institute of Technology in Southern Sweden – A Study Under the Direction of Lund University and The Scania Chamber of Commerce in Collaboration with The Scanian Engineers' Club and the Lund University Students' Union.

The report submitted was only 23 pages long, but despite its brevity it presented the advantages of establishing higher education in engineering in Lund, for example, the lower cost of living for students!

The Lund Institute of Technology is born



LUNDS UNIVERSITET
Lunds Tekniska Högskola

Initially, the Lund Institute of Technology (LTH) was an independent establishment for higher education, like its counterparts in Stockholm and Gothenburg. It was run by an organising committee under the auspices of the Ministry of Industry. However, its status was far from clear, and lively discussions developed towards the end of the 1960s.

Most of the *engineers* wanted its independent status to continue, while representatives of the University argued that the symbiosis between the two establishments would be beneficial to all. The organising committee was divided.



A compromise

It was not until a group of experts was appointed with representatives outside the University that a unanimous proposal was put forward. In 1968, the Swedish Parliament decided that LTH should be an institute of technology, constituting the Engineering Faculty of Lund University.

Most of LTH's lecturers and students did not welcome this decision. Many remembered the early days, when decisions could be made easily and quickly, and job satisfaction combined with a pioneering spirit led to continuous development and expansion.



The first engineers graduated in Lund in 1965; here seen showing off their graduation rings. Inger-Lena Lamm, in the centre of the photograph, went on to obtain a PhD in the field of deformed atomic nuclei under Professor Sven Gösta Nilsson, and later worked as a medical physicist at Lund University.

A boost for physics in Lund

Apart from the new students, the establishment of LTH meant that the number of lecturers and researchers in physics grew considerably. Many talented physicists were able to remain in Lund, while others were recruited from other seats of learning.

Prior to 1961, the subject of physics had four professors and two assistant professors. In 1969, six new professors were appointed, together with a number of lecturers, bringing the total number of academic staff in physics to twenty, more than tripling the original number.

The expansion of the Department of Physics (in red) following the establishment of LTH.

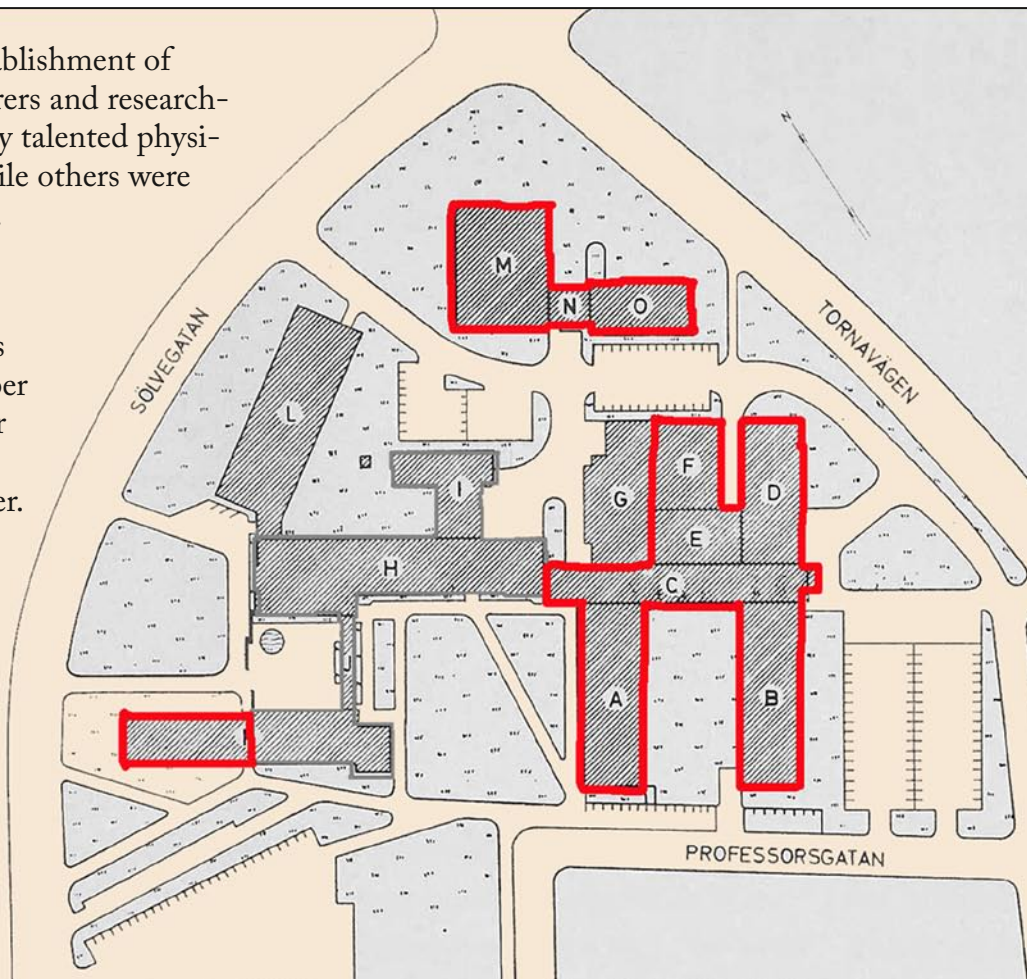

Physics flourishes in Lund

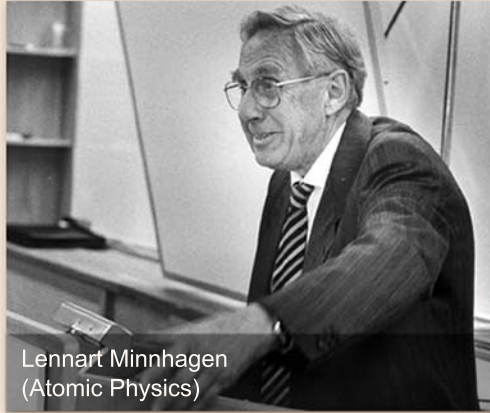

Lennart Minnhagen
(Atomic Physics)

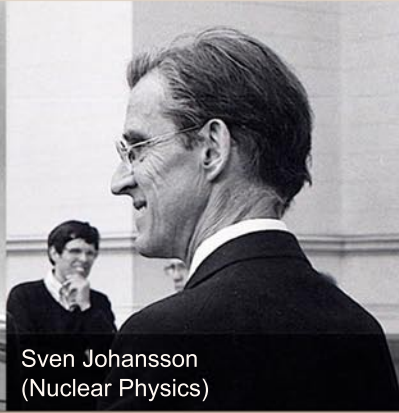

Sven Johansson
(Nuclear Physics)

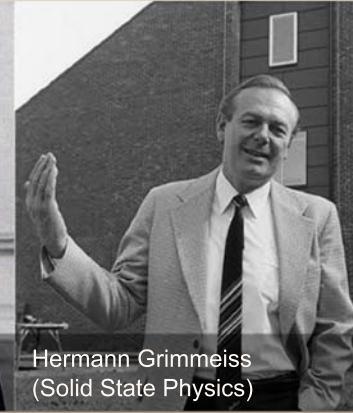

Hermann Grimmeiss
(Solid State Physics)

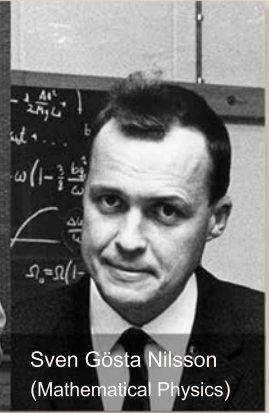

Sven Gösta Nilsson
(Mathematical Physics)

Three of the new professors at LTH, Lennart Minnhagen, Sven Johansson and Sven Gösta Nilsson, had previously worked at the Department of Physics. Two other physicists from Lund, Hellmuth Hertz and Lennart Stigmark, became professors in Electrical Engineering at LTH. The number of other staff increased, as did funding and the size of the actual department, in an unparalleled expansion of intellectual and material resources.



Ulf Uhlhorn
(Mechanics)



Lennart Stigmark
(Electronics)



Hellmuth Hertz
(Electrical Measurements)



LUSY is dead – long live MAX!

Research in the field of subatomic physics suffered a considerable setback in 1972 when the Nuclear Research Council announced drastic cutbacks in their financing of LUSY, the Lund University Synchrotron. Funding was reduced from 3.4 to 1.2 million SEK per year, and the number of positions from 30 to 9.

The Faculty of Science at Lund University was unable to compensate for this reduction and, somewhat surprisingly, help came from LTH.



Lars Persson, one of the engineers, working on the electron synchrotron, LUSY.

MAX – Microtron Accelerator for X-rays

LTH took over responsibility for two important positions and, by coincidence, was also able to provide room for a new facility: MAX-lab.

The idea of creating a source of high-energy electrons arose from discussions between physicists in Lund, at first hand Bengt Forkman, and the Swedish scientific research councils.

The concept was later extended to include synchrotron radiation; an extremely powerful and well-defined light source. One could almost say that MAX rose, like a phoenix, out of the ashes of LUSY.

During the development of the project, the skilled workshop staff at the Department of Physics proved to be an invaluable asset, allowing considerable savings to be made in the design and construction of much of the equipment.



Leif Thånell, research engineer.



Nils-Erik Persson, instrument maker.

One machine hall too many

Where to house the new facility?

The buildings used to house the various departments of LTH were constructed according to the standards and requirements of the 1950s. Large-scale experimental work was to be carried out in two machine halls, each 1600 m². The equipment in the northern machine hall was considered to be outdated, and the University Board decided this would provide a suitable location for the MAX project.



From the left:

Bengt Forkman (Director of MAX-lab), Lillemor Persson Ekstedt, Mikael Eriksson (chief designer and head of experimental activities), Leif Thånell, Lars Johan Lindgren, Lars Gösta Johansson, Lennart Lundin, Nils-Erik Persson, Wilhelm Key, Olle Cederholm, Lars Hansson, Bo Persson, Mats Nilsson, Werner Stiefler, Bengt-Erik Wingren, Kurt Hansen, and Johnny Roslund.

Towards a national laboratory

The decision to locate MAX-lab at LTH was very controversial. It meant a drain on the resources of the Faculty of Engineering, at a time when transfers between different faculties were not normally part of University policy.

However, the decision afforded MAX legitimacy with central authorities; no one could doubt the commitment of Lund University to the project. Interest in the MAX project at the Department of Physics was mixed, which had the effect of creating greater scope for national responsibility.

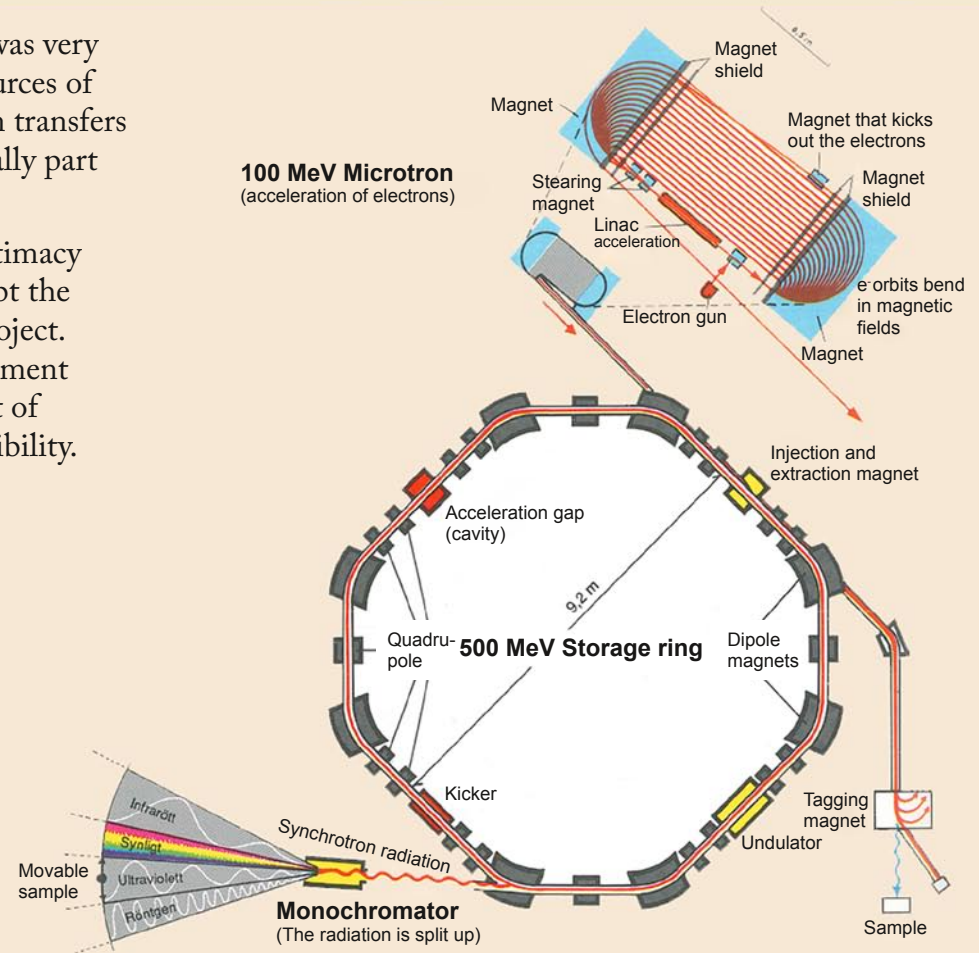

MAX-lab was formally opened in January 1987.

A national facility

The decision was made early on that MAX-lab would be an independent entity, providing a resource for the whole University, but mainly the faculties of Science, Engineering and Medicine. This facilitated its financing, both locally and by government authorities and foundations. MAX-lab soon became a national resource.

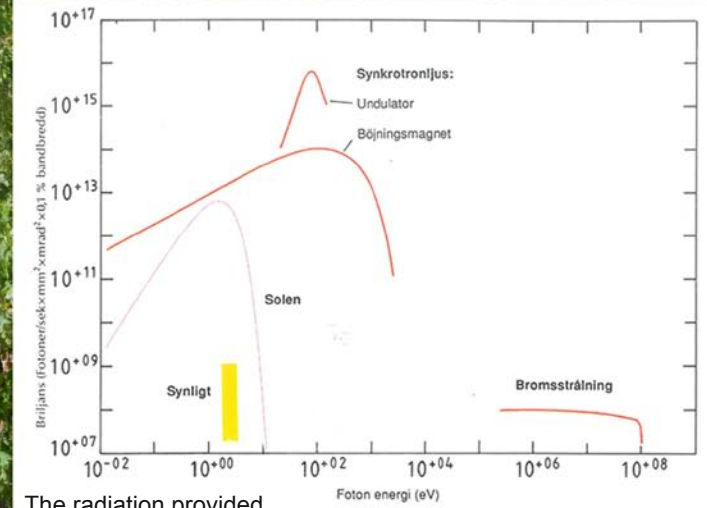

The radiation provided by MAX-lab has higher brilliance than the sun.

The MAX IV Project

After 25 years of experience of synchrotron radiation, a new synchrotron radiation source is being built in Lund: MAX IV. The site is located three kilometers north-east of the original MAX-lab.

According to the University Board, the reasons for the later successes of MAX-lab are the scientific competence at Lund University and the tradition of spectroscopy at the Department of Physics. The University is also proud of being host to a national facility with a good international reputation.



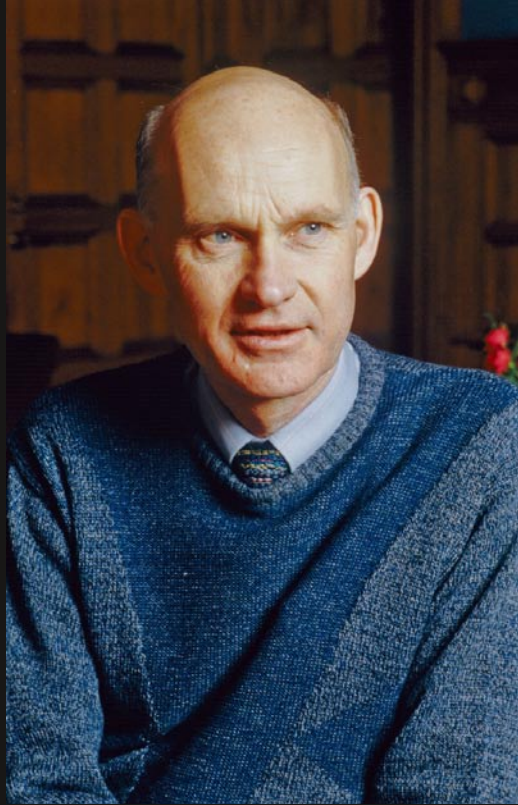

Lars Hedin and the theory of solid state physics

How Lars Hedin's own work and the theoretical research in solid state physics began and developed in Lund under his leadership.

The beginning – a student in engineering physics

Lars Hedin was born in Örebro on 6th February 1930. Both his father and grandfather were electrical engineers, but Lars decided to study Engineering Physics at the Royal Institute of Technology (KTH) in Stockholm. This programme had an especially high status, and was considered to prepare students for a career in research.

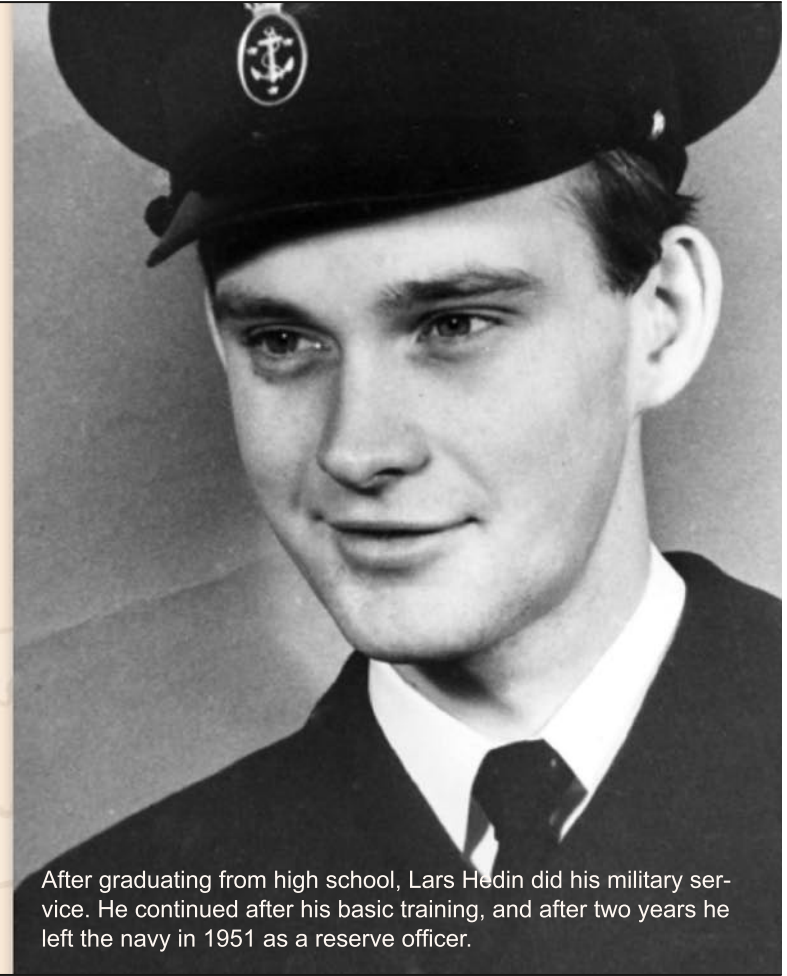

After graduating from high school, Lars Hedin did his military service. He continued after his basic training, and after two years he left the navy in 1951 as a reserve officer.

The many-body problem

After obtaining his Master's Degree in 1955, Hedin continued to study under Professor Lamek Hultén, resulting in a Licentiate Dissertation on the elastic properties of crystals in 1960.

His next place of study was Uppsala University, in the recently started research group in quantum chemistry, where he met the passionate scientist Stig Lundqvist, a leading figure in international physics research during the 1970s and 80s.

Together, Hedin and Lundqvist set about the application of quantum field theory and Feynman diagrams, which had been so successful in nuclear and particle physics, to the many-body problem, which is of considerable importance for our understanding of solid bodies.



Professor Stig Lundqvist at the International Centre for Theoretical Physics (ICTP) in Trieste, Italy, at the end of the 1980s.

Argonne National Laboratory



PHYSICAL REVIEW VOLUME 139, NUMBER 3A 2 AUGUST 1965

New Method for Calculating the One-Particle Green's Function with Application to the Electron-Gas Problem*

LARS HEDIN†

Argonne National Laboratory, Argonne, Illinois

(Received 8 October 1964; revised manuscript received 2 April 1965)

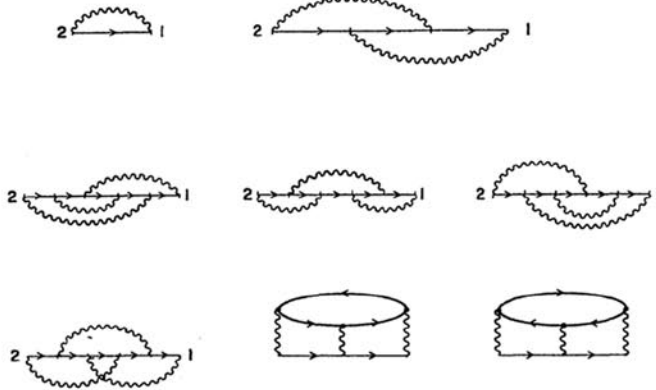

Diagrams representing the expansion of $M(1,2)$. The one-particle Green's function $G(1,2)$ is represented by an arrow from 2 to 1, and the screened potential $W(1,2)$ by a wiggly line between 1 and 2.

As a result of their research at Uppsala, Hedin and Lundqvist became Swedish pioneers in this new exciting field of theoretical physics. Thanks to this success, Hedin was given a grant to work at Argonne National Laboratory in the USA, between 1962 and 64.

His research there was very successful, and resulted in a well-known article in the renowned journal *Physical Review*, which laid the ground for the famous *GW approximation*. To date, this article has over 2000 citations.

The GW approximation

Lars Hedin's *GW approximation* is still the standard method used to calculate the band gap in semiconductor materials. This is important in the search for new semiconductors that can result in better light sources and even faster electronic components.

With this theory it became possible, for the first time in the 1980s, to calculate band gaps using only natural constants such as the elementary charge and Planck's constant.



In 2005, hundreds of researchers from all over the world met at Bad-Honnef in Germany for a conference entitled *40 Years of GW*, in recognition of Lars Hedin and his important contributions to the field.

Dissertation

After his time at Argonne National Laboratory, Hedin and his family moved to Gothenburg. Hedin took up a lectureship at Chalmers University of Technology (CTH), where his colleague, Stig Lundqvist, had been awarded a professorship in the previous year, in 1963.

Based on the work he had performed at Argonne, Hedin presented his doctoral thesis entitled, *Application of Many-Body Theory to the One-Electron Problem of Atoms, Molecules and Solids* on 30th October 1965.



Lars Hedin defending his doctoral thesis in 1965. His examiner (left) was Alf Sjölander, only three years Hedin's senior, and one of Sweden's most talented theoretical physicists of all time.



Research at Chalmers University of Technology



Hedin explaining his version of the many-body theory to colleagues at CTH.

Hedin's time at CTH was extremely productive, and new ideas came one after the other. Many of Hedin's findings and ideas have been collected in a review article, written by him together with Lundqvist, and published in 1969 in the journal *Solid State Physics* (Vol. 23). This publication is often cited, and is still a source of inspiration to many researchers.

Professor at Lund University



The Theoretical Physics Group in 1971. Back row:
Lars Hedin, Lars Silverberg, Rolf Riklund, Petter Minnhagen,
Lars Gislén, Stellan Löfdahl, Bengt Kjällerström.

Front row: Bengt Månsson, Günter Grossmann, unknown,
Ulf von Barth, Ingrid Hjelt, Inga Belin, Margareta Bergsten,
Bengt EY Svensson, Carl-Olof Almladh.

Following his lectureship at CTH, Hedin became Professor of Theoretical Physics at the new institute of technology in Linköping. However, less than a year later, he was offered a professorship in theoretical physics at Lund University, and moved to Lund, together with his family, in 1971. At that time, the newly established and rapidly expanding field of solid state physics in Lund was well-represented experimentally, but there was only one lecturer engaged in the theoretical side of the subject.

Enthusiastic PhD students

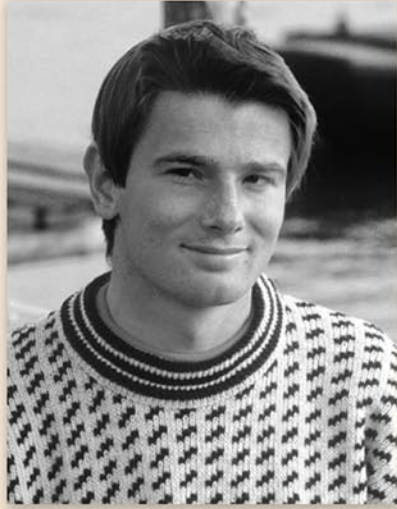

Carl-Olof Almbladh

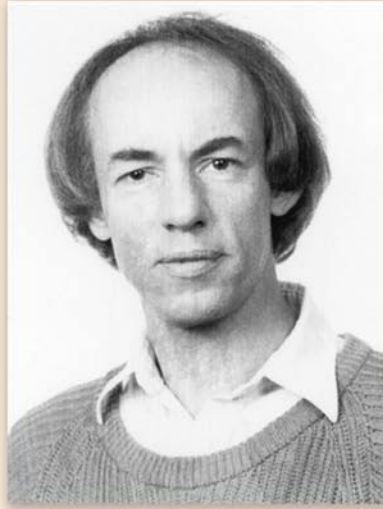

Ulf von Barth

When Hedin arrived in Lund, Bengt Kjällström had collected a group of enthusiastic PhD students who were eager to study the new subject of theoretical solid state physics with Professor Hedin. Hedin's first PhD students from CTH, Ulf von Barth, Carl-Olof Almbladh and Ingvar Hulthén, had followed him to Lund, and together with new PhD students, they formed a large research group. Hedin was an enthusiastic, easy-going supervisor, allowing students to take their own initiative.

International success

A very successful period in Lund followed. Hedin's research group consisted of five or six researchers and a considerable number of PhD students. The group was rated among the best in the world during this period by various research councils.

Two of Hedin's most important, and today most frequently cited, publications from the beginning of the 1970s are on density functional theory; the first written by Hedin and Bengt Lundqvist at CTH, with about 3000 citations, and the second written by Hedin and his first student, Ulf von Barth, with about 5000 citations.



Aspenäsgården 1976.





An inspiring environment

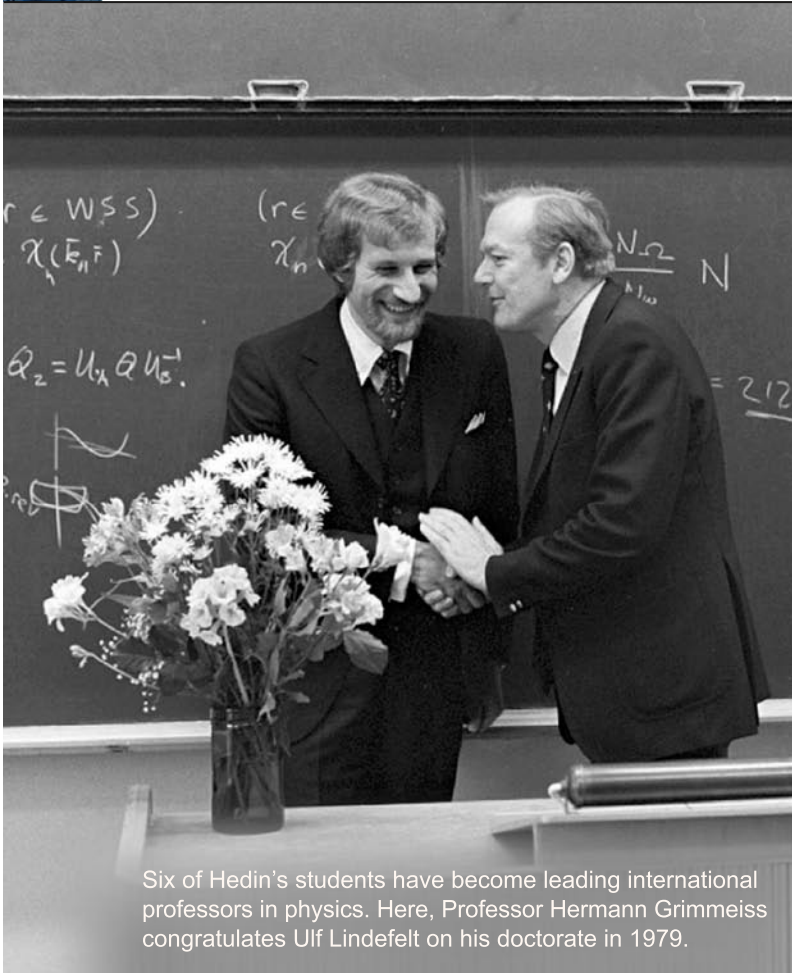

Six of Hedin's students have become leading international professors in physics. Here, Professor Hermann Grimmeiss congratulates Ulf Lindefelt on his doctorate in 1979.

Thanks to Hedin's many international contacts, his students came into contact with a steady stream of renowned researchers in the field, including Bob Schrieffer, John Bardeen, Sir Nevill Mott, Walter Kohn, Ivar Giaever, Leo Esaki, Gordon Baym, Niel Ashcroft and Ole-Krogh Andersen.

Hedin and his wife Hillevi regularly invited both students and researchers into their home, creating a warm and inspiring environment.



Hedin's research group

At the time this photograph was taken, Carl-Olof Almbladh and Lars Hedin had just published their review article on theoretical spectroscopy in the *Handbook on Synchrotron Radiation*. This has become a standard text in the field, and is still often cited with reverence by today's researchers. Ulf von Barth was, at that time, one of the most well-known researchers in density functional theory. David Yevic and Witold Bardyszewski were visiting researchers in Hedin's group. Carlos Pedrosa and Alvaro Morales were Almbladh's PhD students, and Ulf Lindefelt was the group's solid state theoretician.



The Theoretical Solid State Research Group in 1984. From the left: Alvaro Morales, Witold Bardyszewski, David Yevic, Carlos Pedrosa, Ulf Lindefelt, Lars Hedin, Ulf von Barth, Carl-Olof Almbladh.



Max Planck Institute in Stuttgart

As Hedin's theories became increasingly used in practical applications, his reputation spread throughout the world. Despite this, his research group was reduced to about half its original size by the beginning of the 1990s.

It was therefore no surprise that he accepted a four-year position as Director of Research at the Max Planck Institute in Stuttgart in 1994. This marked the beginning of a new fruitful period with many publications. Among other projects, Hedin continued work on his theory of what he called *the blue electron*.



A Lego-building competition between research groups at the Max Planck Institute in Stuttgart. Lars Hedin's group won the cup from Ole Krough Andersen's group. The theme for the competition, *Upside Down*, was thought up by Laura Gunnarsson, and Ove Jepsen secured a donation of Lego from the manufacturer in Denmark.

ETSF



Hedin's research also forms the basis for a European network, The European Theoretical Spectroscopy Facility (ETSF), which brings together experience and know-how to facilitate collaboration and the rapid transfer of knowledge between over 200 researchers from 68 research groups in Europe and the USA.

The network functions as a knowledge centre in the field of theoretical spectroscopy for research on theoretical and computational methods that make it possible to study the electronic and optical properties of materials.

Many-body perturbation theory
 Prof. Dr. Arno Schindlmayr
 Department Physik, Universität Paderborn

Linear response of the spin density within the GW approximation

$$\chi^s(\mathbf{r}, \mathbf{r}', t-t') = \frac{\delta S^s(\mathbf{r}, t)}{\delta B_{\text{ext}}^s(\mathbf{r}', t')} \rightarrow -i \lim_{\omega \rightarrow 0} \sum_{\mathbf{r}''} \frac{\delta G_{\text{GW}}^s(\mathbf{r}, \mathbf{r}''-t')}{\delta B_{\text{ext}}^s(\mathbf{r}'', t')}$$

$$G(\mathbf{r}, \mathbf{r}', \omega) = G_0(\mathbf{r}, \mathbf{r}', \omega) + \int G_0(\mathbf{r}, \mathbf{r}'', \omega) \Sigma(\mathbf{r}'', \mathbf{r}', \omega) G(\mathbf{r}'', \mathbf{r}', \omega) d^3r'' d\tau''$$

$$\chi(\mathbf{r}, \mathbf{r}', \omega) = \frac{i}{2\pi} \int G(\mathbf{r}, \mathbf{r}', \omega + i0^+) W(\mathbf{r}', \mathbf{r}', \omega) d\omega$$

Dynamic transverse spin susceptibility

Bethe-Salpeter equation

Additional approximations:

- Static screening $W(\omega) = U$
- Electron-hole scattering only at the same atomic site

Arno Schindlmayr presenting his latest results on the dynamic spin susceptibility, based on Hedin's *GW approximation*, at the 2008 ETSF conference in Pugnochiuso, Italy.

Useful theories

Hedin's attitude regarding his research, was that his theoretical work should lead to computational methods that provide practically useful results. Mathematics and complicated equations were not ends in themselves, as far as he was concerned. Hedin often demonstrated his theoretical results by applying them to less complicated model systems.

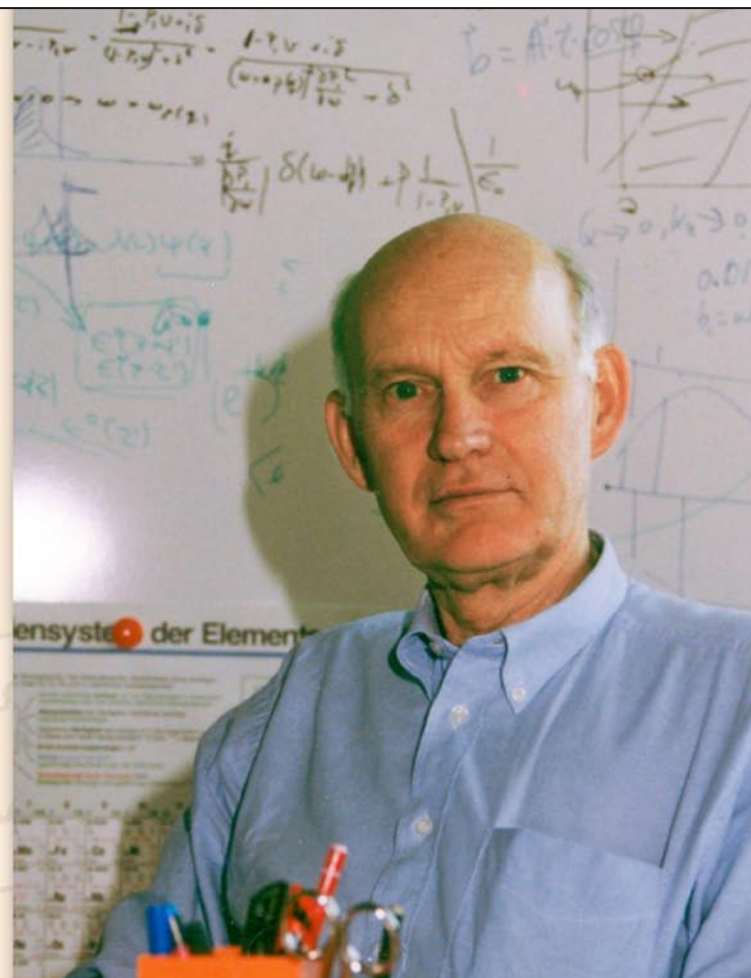

Hedin's easily recognisable writing in the many-body equations on the whiteboard in his office at the Max Planck Institute in Stuttgart.

Lars Hedin's legacy

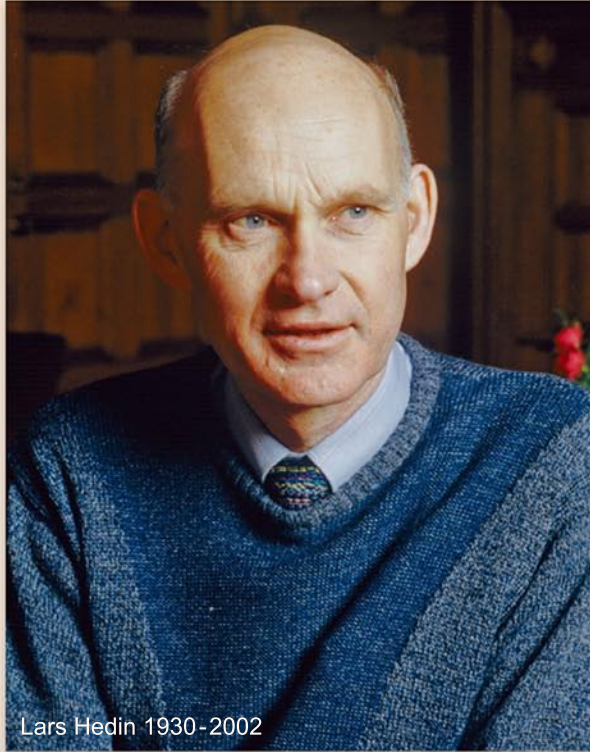

Lars Hedin's last great success came posthumously in 2008, when an international committee of experts assessed a number of research groups from all the faculties at Lund University (RQ08).

Hedin's pupils, Ulf von Barth och Carl-Olof Almladh and their research group, were identified as one of the twenty best groups at Lund University. Other research groups in physics received good reviews, and the discipline of Physics was thus identified as one of the *jewels in the crown* of Lund University.



$$\begin{aligned}
 & \langle \psi | H | \psi \rangle = 0 \\
 & \frac{d}{dt} \int \psi^* \psi d^3r \\
 & \langle \psi_n | v_{\text{ext}} | \psi_n \rangle = 0 \\
 & \mathcal{L}(r) \langle \psi(r) | \psi(r) \rangle \\
 & \int n(r) \epsilon_{xc}(n(r)) dr \\
 & \frac{\delta E_{xc}}{\delta n(r)} = v_{xc}(r)
 \end{aligned}$$

Theoretical condensed matter physics

Theoreticians at the Division of Mathematical Physics are working to understand and predict the quantum mechanical properties of matter on the subatomic, atomic, and nanometre scales.

Our knowledge of materials

One of the great challenges in physics is to understand, control, and exploit the properties of materials in novel ways. This requires an accurate, and preferably predictive, theoretical description of materials.

This is not easy for several reasons, e.g. some materials have a highly complex structure, or it may be necessary to consider several length- and time-scales simultaneously to predict the functional properties of interest. Furthermore, novel properties often emerge when the interactions among electrons and between electrons and lattice vibrations play an important role.

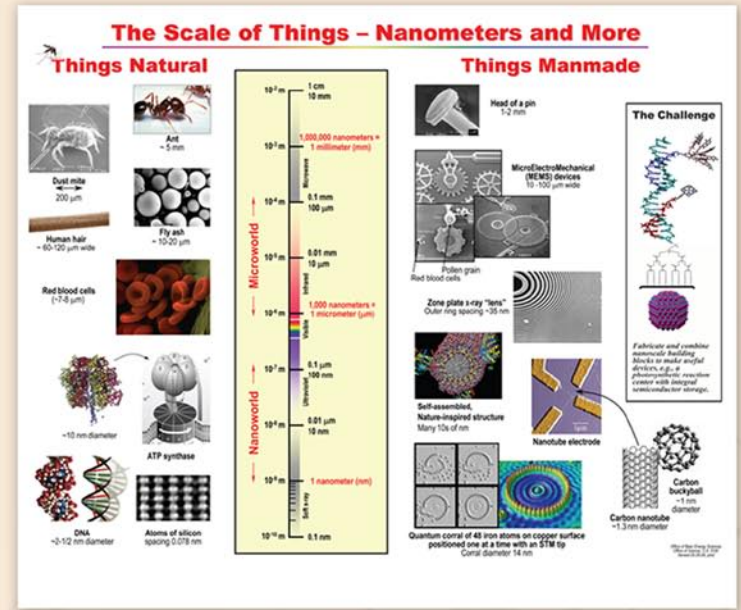

Time-dependent fields

Carl-Olof Almladh has worked on combining advanced theories related to relevant experiments. His main areas of interest include self-energies and excitation energies, density functional theory and various forms of spectroscopy and, more recently, systems with strong correlations, nanoscale systems and systems in external time-dependent fields.



Correlated nanosystems

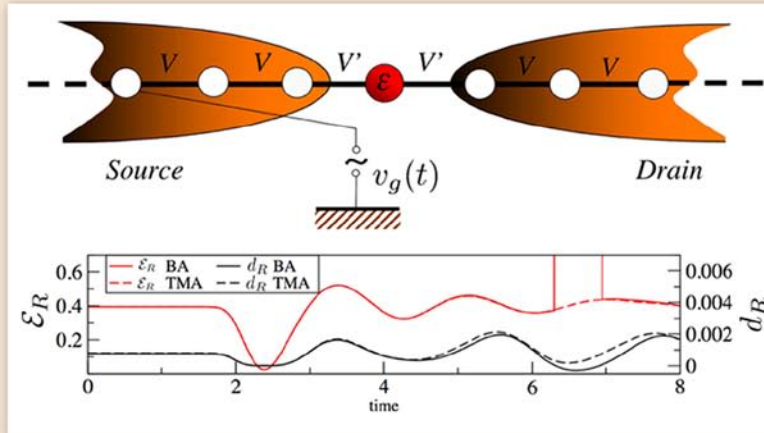

Double occupation in a nanoscopic scale conductor, according to the work of Puig von Friesen, Verdozzi, and Almladh in 2011.

A key experiment in nanophysics is quantum transport, where current flows through a nanoscopic system (e.g. a molecule) connected to external electrodes.

Stefanucci and Almladh have developed a theory in which the system is studied when it is disturbed from its equilibrium state by externally applied, possibly time-dependent, fields and voltages at the electrodes. Work on this has been continued by Almladh and Verdozzi and their students through the development of theories and detailed calculations of strongly correlated nanosystems.

The final-state rule

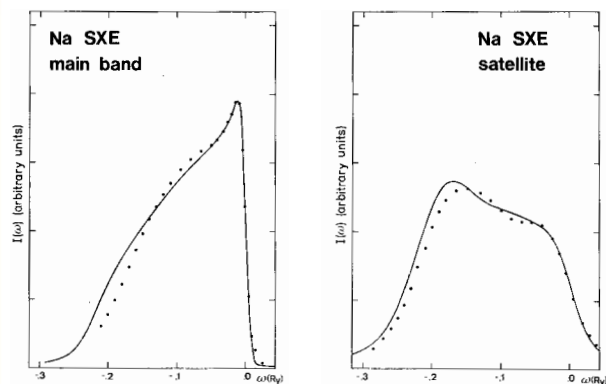

Ulf von Barth in conversation with Günter Grossmann's examiner, Professor David C Langreth.

Ulf von Barth's first PhD student, Günter Grossmann, obtained his PhD in 1981. His work included the numerical evaluation of a model describing X-ray and Auger electron spectra. The model reproduced the shape of the X-ray edges well. Most importantly, the model provided theoretical support for *The Final-State Rule*. This rule explains, for example, why we see no effects of the inner-shell tail in X-ray emission, while it is seen in the corresponding satellite spectrum or why KLV Auger spectra are strongly affected by the vacancy, while KVV spectra are not.

Time-dependent density functional theory

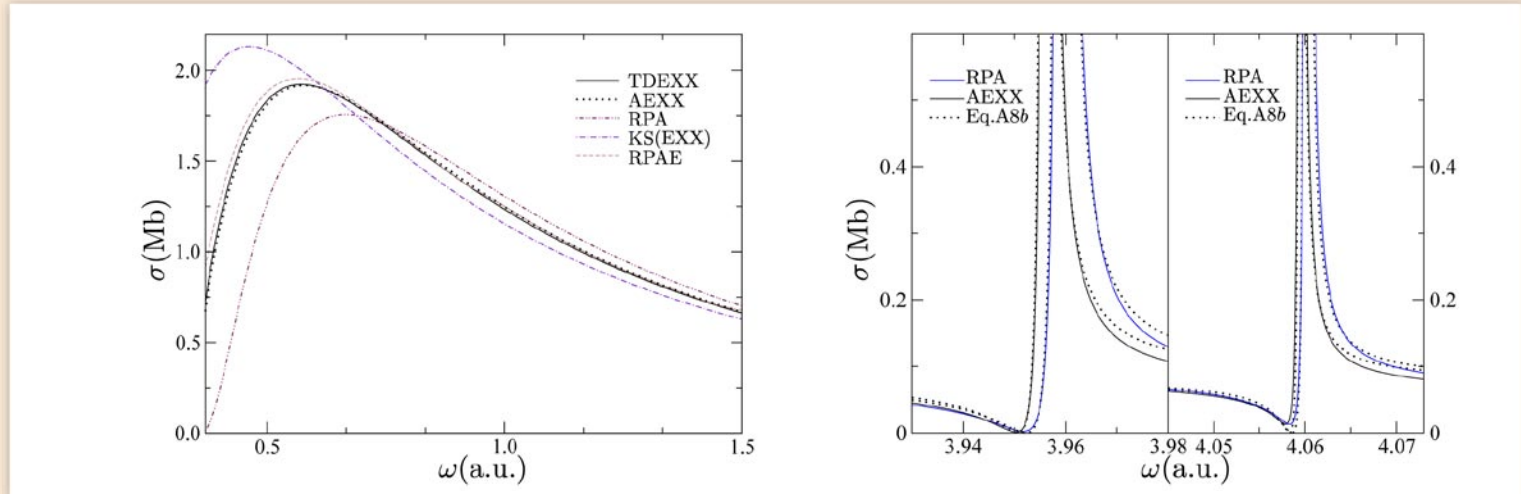

Top left: Photoionization cross section for Be after the first ionization threshold.

Top right: First two Fano resonances resulting from the $1s \rightarrow 2p$ and $1s \rightarrow 3p$ transitions.

Density functional theory (DFT) provides a way of simplifying the complicated many-body problem to a single-body problem. Ulf von Barth has devoted a great deal of his research to the DFT, and was one of the world's leading experts in the field. Amongst other things, von Barth showed that the eigenvalues predicted by the theory do not describe the band gaps in semiconductors. An early paper by von Barth and Lars Hedin, generalizing the theory to magnetic material, has about 5 000 citations.

In more recent years, von Barth has been working on a time-dependent variant of DFT (TDDFT), which allows calculations of excitations. One of von Barth's PhD students, Maria Hellgren, showed that a certain approximation worked well for low-energy spectra.

The electronic structure of strongly correlated compounds

Approximate practical methods of applying quantum mechanics should be developed which can lead to an explanation of the main features of complex atomic systems without too much computation.

Paul Dirac

In the last few decades many new compounds with intriguing properties have been synthesized and discovered. They are expected to form the foundation of future electronics. A famous example is the unconventional high-temperature superconductors.

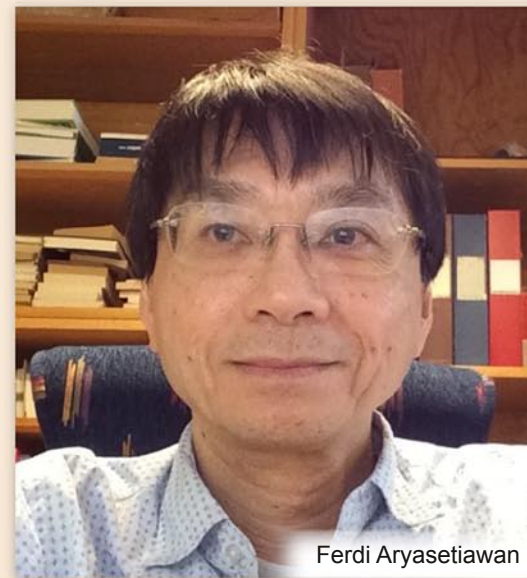

Future electronics

The mission of Aryasetiawan group is to develop quantum mechanical methods to study the electronic structure of these complex compounds. In the spirit of Dirac, a strict criterion to be fulfilled is that the method must be theoretically rigorous and at the same time applicable to real materials.

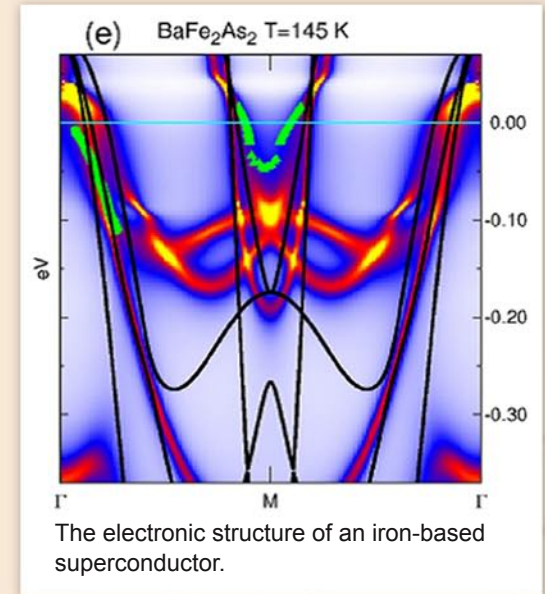

Non-equilibrium phenomena

Many future cutting-edge technologies will likely rely on small ultrafast devices, operating in rapidly changing environments. Furthermore, there is broad consensus among physicists that ground-breaking technological innovations are likely to be based on systems whose properties cannot be described within an independent-particle picture. This is why considerable research effort is currently being devoted in the condensed matter community to the development of theories for systems with strong inter-particle correlations, in- and out-of-equilibrium.



Time-resolved dynamics of non-equilibrium systems

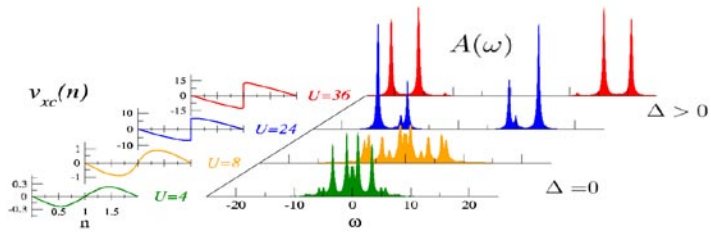

The exchange-correlation potential of DFT in the 3D Hubbard model (left) vs. the metal-insulator transition (right), as a function of electron-electron interactions.

Melting of the Mott insulator phase in a confined fermionic gas according to time-dependent density functional theory.

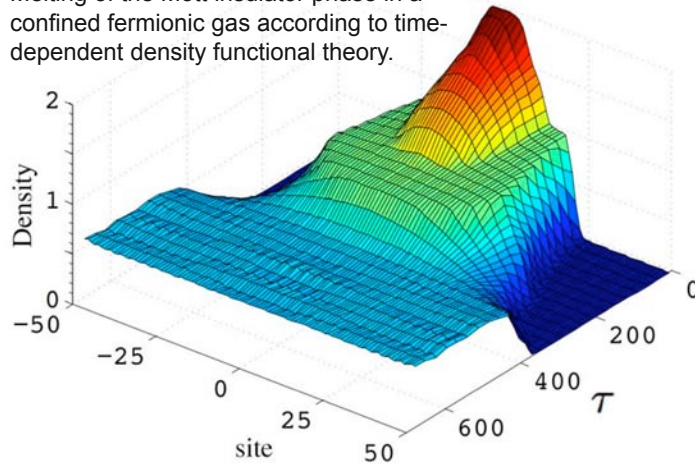

Since his arrival in Lund, in 2004, Claudio Verdozzi's research has been devoted to developing and applying theoretical and numerical methods to systems with correlations among particles in- and out-of-equilibrium, such as *Green's* function methods, density functional theory and, for finite systems, exact numerical schemes.

The goal is to address open conceptual issues inherent in these approaches and describe situations as diverse as electron transport in nanodevices (together with Carl-Olof Almbladh), ultracold atoms in optical lattices, magnetic clusters, disordered systems and ultra-fast spectroscopy.

The beginning of nanoscience

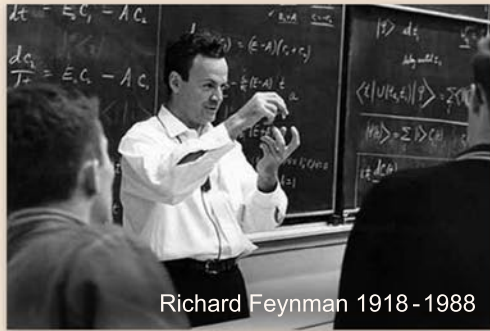

Richard Feynman 1918-1988

In a prescient lecture at Caltech in 1959, the famous American physicist Richard Feynman predicted a new era in materials science where, instead of exploiting materials found in nature, novel artificial systems are created with properties tailored towards targeted applications.

This would be done by manipulating individual atoms on the scale of nanometres, where quantum mechanical effects dominate.

Since then, this vision has spurred vast theoretical and experimental activity, to conceive and realize novel nanomaterials and the theoretical models required to predict and explain their behaviour.

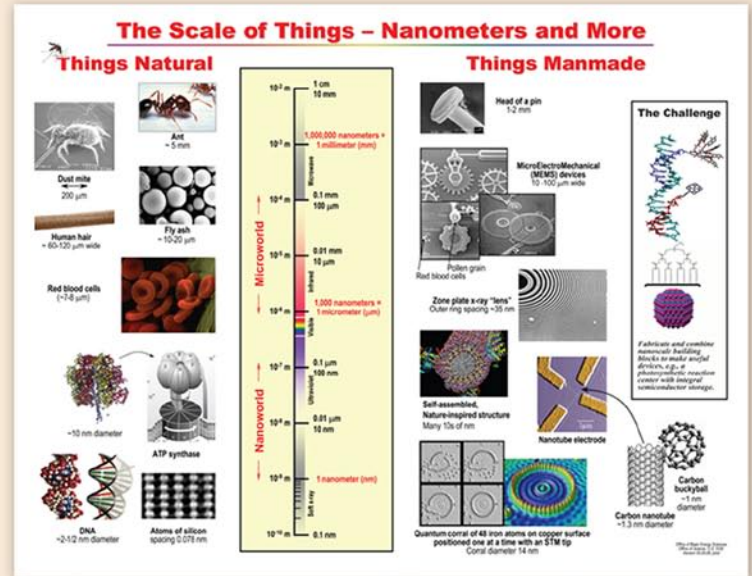

Particle ensembles



Stephanie Reimann

Stephanie Reimann and her research group are working on theoretical calculations on how small systems, on the nanometre scale, consisting of several interacting particles behave.

One example is small semiconductor systems, e.g. quantum dots and quantum wires, where quantum mechanics determine the laws of physics. Here, the interplay and interactions between the particles are decisive for the physical phenomena being investigated, such as correlations in time and space, vortex formations and the shell structure of the energies of the different particles.

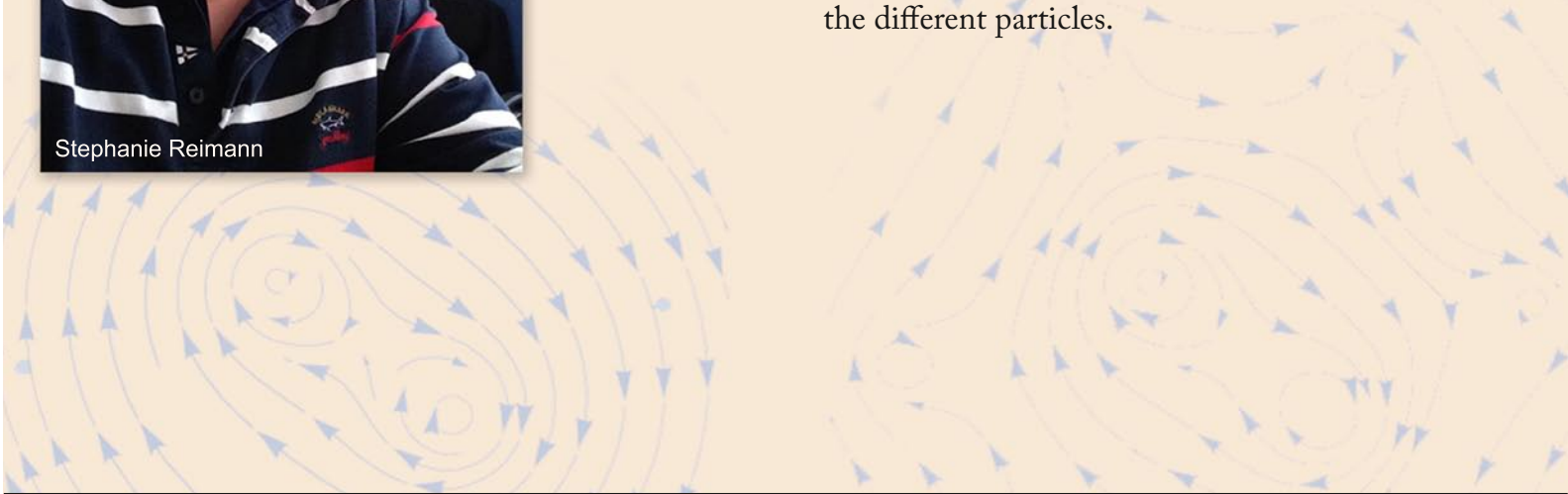

Smart approximations

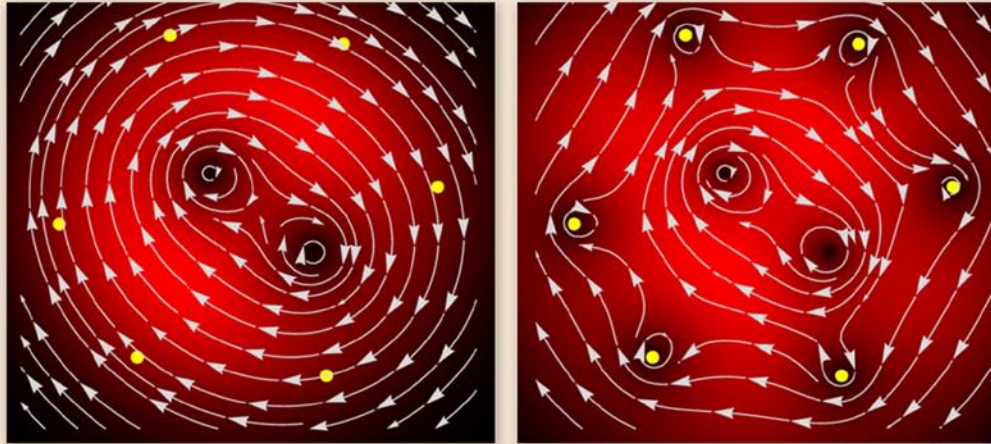

All the particles in the universe can be divided into two types, bosons and fermions. When bosons, such as e.g. different types of atoms, are trapped in small systems, and cooled down to temperatures approaching absolute zero, they can form a *Bose–Einstein* condensate. This very special state can only be explained by quantum mechanics.

Stephanie Reimann and her group have investigated the fundamental properties of Bose–Einstein condensates as well as fermions cooled to very low temperatures. A very interesting example is particles with dipolar properties.



Unexpected relations

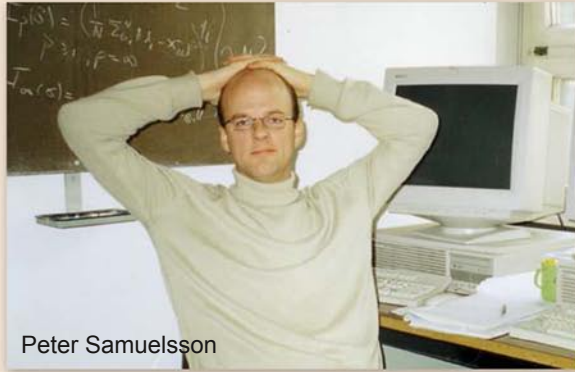

Peter Samuelsson and his research group are working on theories for nanoscale systems, especially the transport of electrons through the system. This may lead to better and faster electronic circuits. Quantum mechanical effects that can lead to more reliable transfer of information than is possible today are of special interest.

Research carried out by the group has revealed unexpected relations between, on the one hand, quantum information and electrons, and on the other, between light from stars at different distances from the earth that reaches the earth simultaneously.

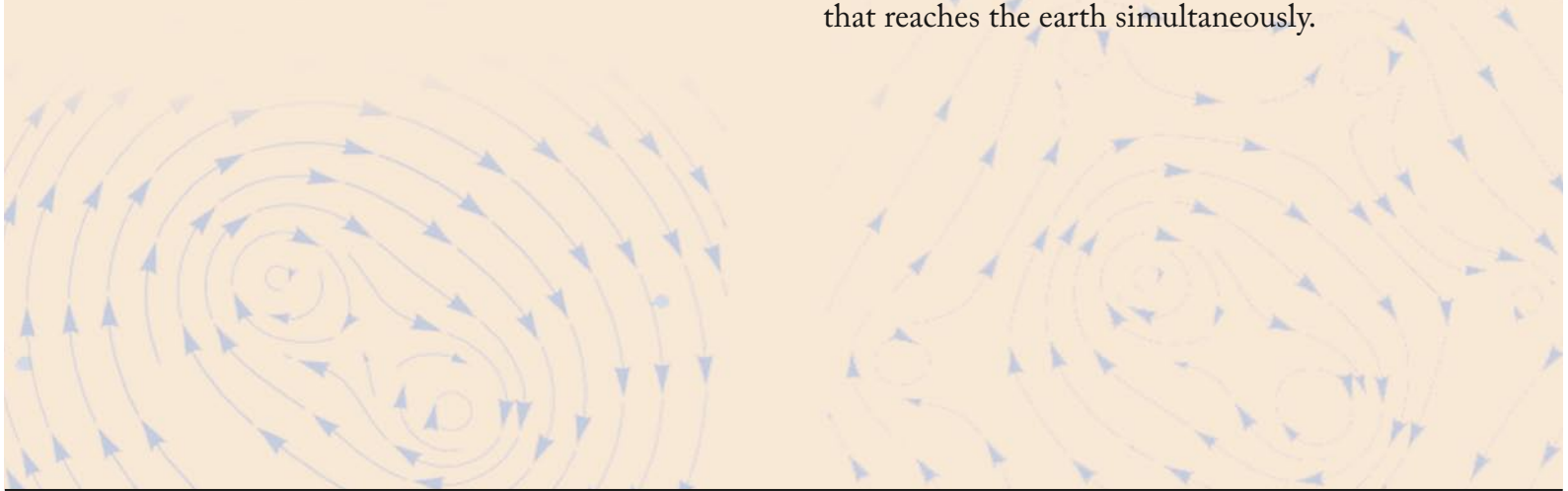

Useful noise

Another area of research is concerned with noise and the fluctuations in the electric current of nanosystems. Noise is usually regarded as a disturbance to be removed, but the noise itself can contain a lot of information in itself, or, to use the scientist Rolf Landauer's words, *the noise is the signal*. Peter and his group have examined several different aspects of noise in nanoscale systems.

Peter Samuelsson and his group have also investigated the effects on temperature and heat generated in nanostructures when quantum mechanics determine the physical properties of the material. It is hoped that it will be possible to find new, more efficient ways of converting heat into electric energy, by using the unique properties of nanosystems.

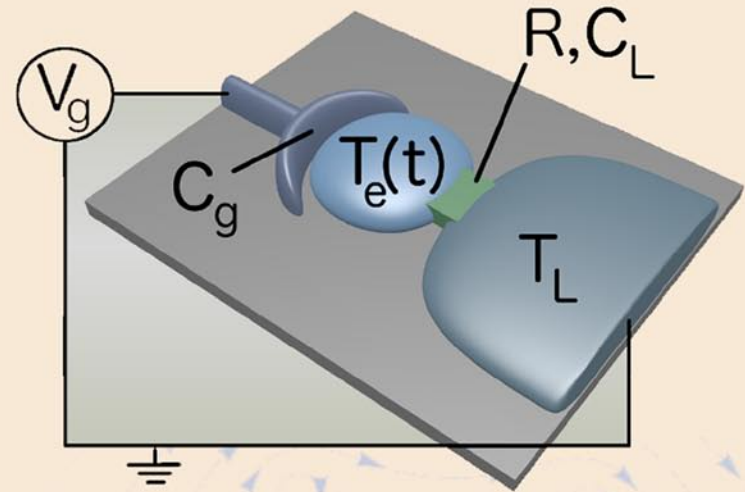

Electrons in confined spaces

Andreas Wacker and his research group are working on theories of how electric current, heat and atomic vibrations, is transported through nanoscale systems made of semiconductor materials. Specifically transportation when the nanosystem is not in equilibrium, leading to interesting physical effects.

Another important area of interest is how to make better lasers in systems built by different, alternating, semiconductor materials. These so-called quantum cascade lasers have numerous exciting applications in everyday life. Andreas and his group studied the basic quantum mechanical phenomena in these alternating layers of semiconductor systems and how these phenomena can be controlled to increase the performance of the lasers.



Andreas Wacker

The quantum cascade laser

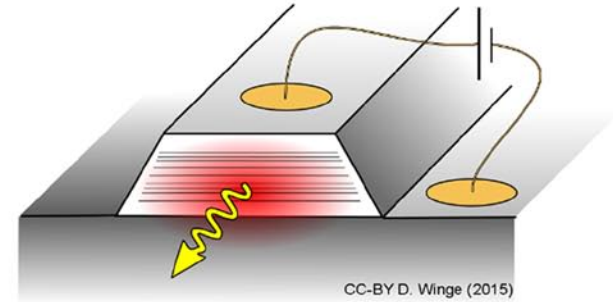
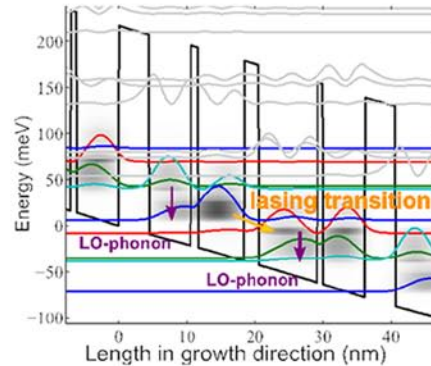

Another area involves transportation through so-called quantum dots, nanoscale specks of semiconductor material. Electrons can jump in and out of the quantum dots and thereby bring both electric charge and heat energy from one side of the dot to the other.

Andreas Wacker has specifically investigated what happens when jumping electrons interact with each other and with the environment in the form of e.g. vibrations of the atoms in the material forming the quantum dot.

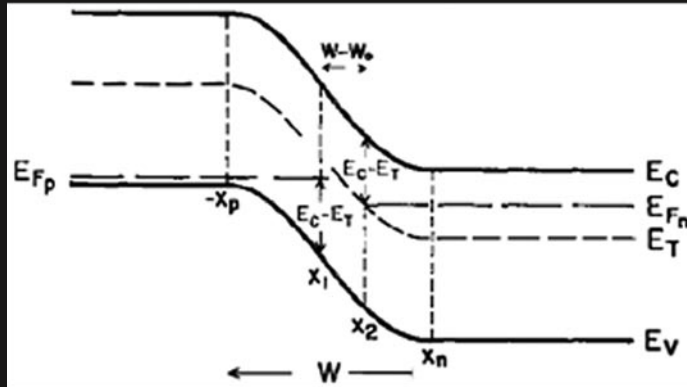

Semiconductor physics

How solid state physics came to Lund.

The transistor

Research into metals in the field of solid state physics was already being performed in the 1910s. Janne Rydberg's PhD student, Gudmund Borelius, was a pioneer in the field in Sweden. However, in 1922 he left Lund to take up a Professorship in Physics at the Royal Institute of Technology (KTH) in Stockholm.

What later came to be called *the electronic revolution* started with the realization of the transistor in 1947. A new era in semiconductor physics had arrived.

However, there was still no organised research in semiconductor physics in Sweden at the beginning of the 1960s.

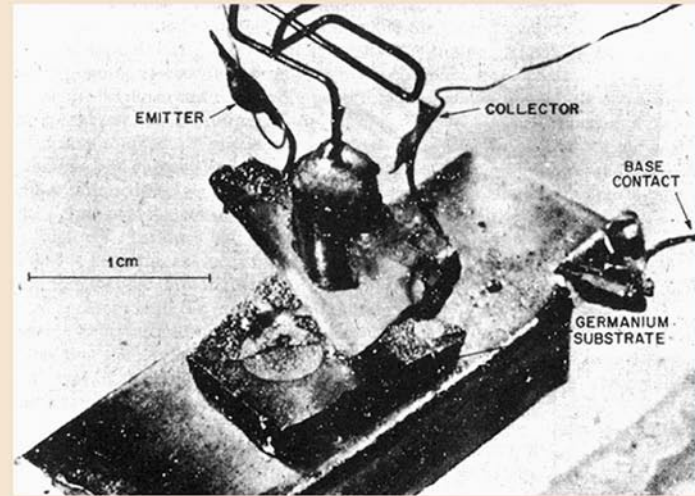

The successor of the electronic valve, the transistor, was first successfully fabricated at Bell Laboratories in 1947 by William Shockley, John Bardeen, and Walter Brattain. Today, transistors are integrated into practically all modern electronics.

A new professorship

Hellmuth Hertz realised the importance of semi-conductors in the field of solid state physics and convinced the powers at LTH that a new professorship was required.

Upon the recommendation of Hertz, a researcher at Philips in Aachen, with considerable experience in semiconductor physics, especially light-emitting diodes, applied for the position. In 1965 Hermann Grimmeiss was appointed Professor in Solid State Physics at LTH.

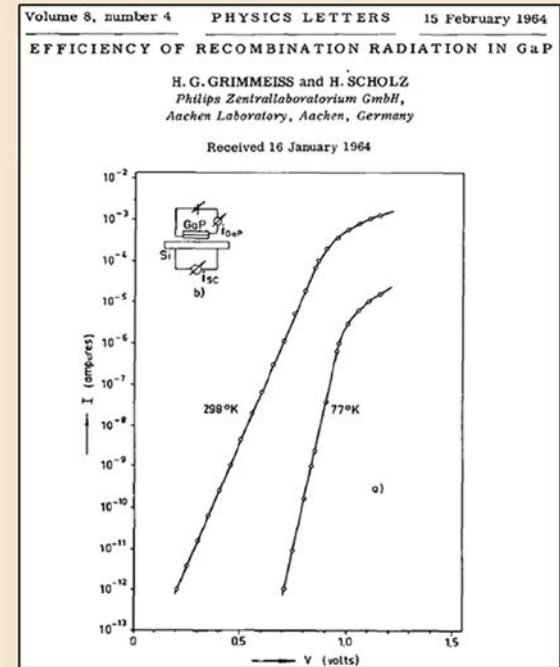

Henry Joseph Round had already created the first light-emitting diode (LED) using silicon carbide in 1907, but it took another 50 years for it to become of any practical use. The first LEDs based on gallium phosphide that found practical applications were reported by Grimmeiss in 1964.

A new division



Members of the Division of Solid State Physics in 1968.

From left to right: Lars Ask, Bo Monemar, Mats-Ola Ottosson, Hermann Grimmeis, Gunnar Björklund, Rune Olsson, Lars-Åke Larsson, Lars Andersson och Erland Ejder.

Hermann Grimmeiss arrived in Lund in 1966, and the new Division of Solid State Physics was located in Building A.

Courses in solid state physics were developed, and the nuclear physicist Lars Ask was employed as the lecturer responsible for undergraduate teaching in the subject.

Most of the literature in the subject was only available in German, so Lars set about translating it into Swedish.

An instrument maker was employed and, with a budget of 280,000 SEK, the division's first purchase was a spectrometer.

New research

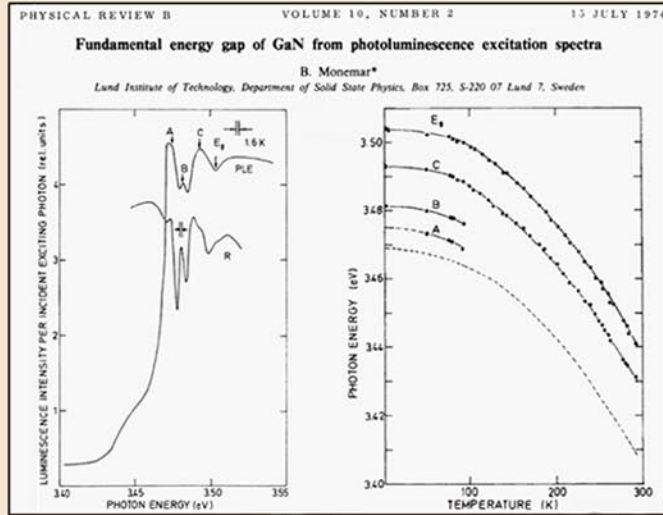

In 1974, Bo Monemar published an article on the band gap in gallium nitride. This is still one of the division's most cited publications.

Research at the new division grew rapidly, and was directed towards two main areas: Electric and photoelectric studies of defects in semiconductors, led by Hermann Grimmeiss and Stellan Braun, and optical properties of semiconductors, led by Hermann's first PhD student, Bo Monemar.

In 1972, Bo recruited his first PhD student, Lars Samuelson, who joined the optics group.

Deep levels

INTERNATIONAL CONFERENCE ON DEEP-LEVEL IMPURITIES IN SEMICONDUCTORS

30 MAY –
3 JUNE
1977

← RECEPTION

Early research was also carried out on the deep levels of semiconductors. Knowledge concerning these levels is important for the understanding of LEDs. In 1977, the division arranged the first international conference solely on this subject of research, in Ystad, southern Sweden. Similar conferences continue to be held every other year at various places around the world, and are still called *the Lund International Conference On Deep-Level Impurities In Semiconductors*, in honour of the founders.

Ann. Rev. Mater. Sci. 1977, 7: 341-76
Copyright © 1977 by Annual Reviews Inc. All rights reserved

DEEP LEVEL IMPURITIES IN SEMICONDUCTORS

H. G. Grimmeis
Department of Solid State Physics, Lund Institute of Technology, Lund 7, Sweden

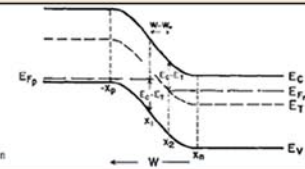

Band level structure of the optically active part of a LED: The p-n junction. In this case, there is a deep level at the energy level E_t .

Politics and microelectronics

In the 1970s, Hermann realised that more effort should be devoted to microelectronics, as a result of the electronic revolution.

New labs and resources were needed, and at the beginning of the 1980s, the Minister for Industry, Thage G Pettersson, agreed, and grants were awarded for the building of new facilities.

The Swedish Government's decision was probably helped along by the high level of unemployment in the building sector at that time.



Politicians and researchers started to meet more often during the electronic revolution.

In 1980, (from left to right) professors Karl Johan Åström and Hermann Grimmeiss, LTH, Swedish Prime Minister Tage Erlander and his wife, Aina Erlander, Minister for Education Carl Tham and Swedish physicist and professor in material science at Stanford Stig Hagström meet in Bommersvik for discussions.

The division gets a new home



Inaugural speech to a packed auditorium.

Hermann and Thage.



Hermann Grimmeiss, Bengt Edlén and Nils Stjernquist at the turf-cutting ceremony.

Work began on the new facility for solid state physics, The Berzelius Lab, named after Jöns Jakob Berzelius, the Swedish chemist who, in 1824, was the first to produce pure silicon. Apart from offices, the new wing of the Department of Physics was to include a modern research laboratory.

The building was inaugurated on 24th May 1984, by the Minister for Industry, Thage G Pettersson, with the aid of liquid nitrogen!

A new tool

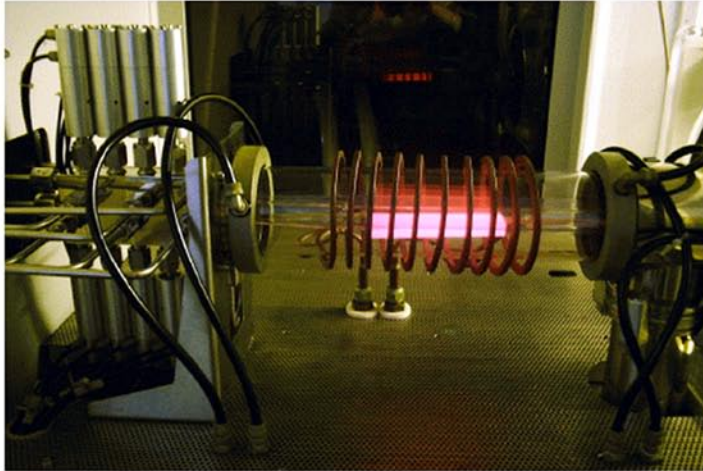

At the beginning of the 1980s, Lars Samuelson started to produce new kinds of materials using an important new method called metal-organic vapour phase epitaxy (MOVPE). With this method, it is possible to tailor semiconductor materials to specific requirements.

The name of the method, epitaxy, is derived from the Greek, *epi* meaning above, and *taxis* meaning in an ordered manner, and makes use of chemical reactions between gas phases.

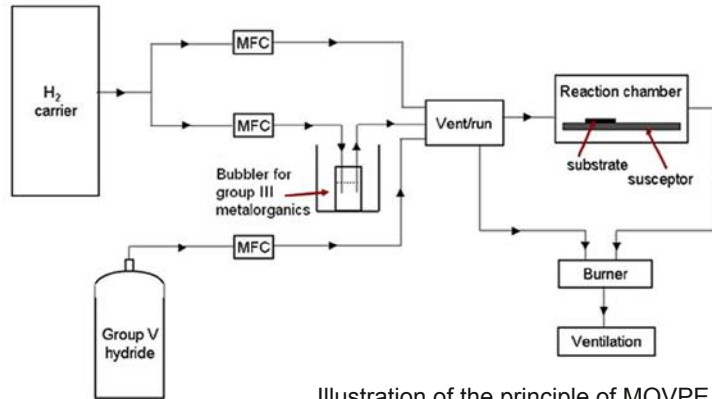

Illustration of the principle of MOVPE.



MOVPE gives results



New fields of research were developed, including Fourier-transform infrared spectroscopy and molecular spectroscopy in semiconductors.

Researchers at the Division of Solid State Physics in Lund were the first in the world to carry out experiments on deep levels with a resolution below 1 meV, and to demonstrate and identify molecular defect configurations in semiconductors.

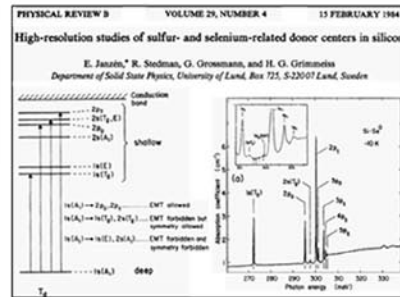
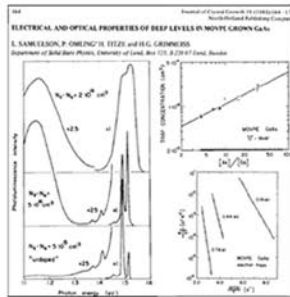

VOLUME 53, NUMBER 15 PHYSICAL REVIEW LETTERS 8 OCTOBER 1984

Direct Evidence for Random-Alloy Splitting of Cu Levels in GaAs_{1-x}P_x

L. Samuelson, S. Nilsson, Z.-G. Wang,^(a) and H. G. Grimmeiss
Department of Solid State Physics, University of Lund, S-22007 Lund, Sweden

$$P(m, N - m) = \binom{N}{m} x^m (1 - x)^{N - m}$$

International recognition



Prins Bertil, Hermann Grimmeiss and Lars Samuelson.



In 1986, Hermann Grimmeiss and his researchers arranged the renowned international semiconductor conference, ICPS, in Stockholm.

Among the 1 100 participants were guests of honour such as Prince Bertil of Sweden and the Nobel Prize winners Kai Siegbahn and Klaus von Klitzing.

Solid State Physics expands

BERZELIUSLABORATORIET

In 1988, the division appointed its second professor, Lars Samuelson, in Semiconductor Electronics.

Research at the division expanded in 1990 when Lars started the Nanometer Consortium, where activities are directed towards extremely small structures, of the order of nanometres, 10^{-9} meter.

The division then consisted of about 40 employees.



Members of the division outside the Berzelius Lab in 1986.

A change in leadership

After 30 years at the helm, Hermann Grimmeiss retired in 1996, and Pär Omling was appointed Professor in Solid State Physics, and Head of Division.

Five years later saw another change in leadership as Pär was appointed Director General of the Swedish Research Council, and Lars Samuelson took over.

In 2010, Heiner Linke became Head of Division, and three years later he handed over responsibility for the division to Dan Hessman, and took over as coordinator of the Nanometer Consortium after Lars.

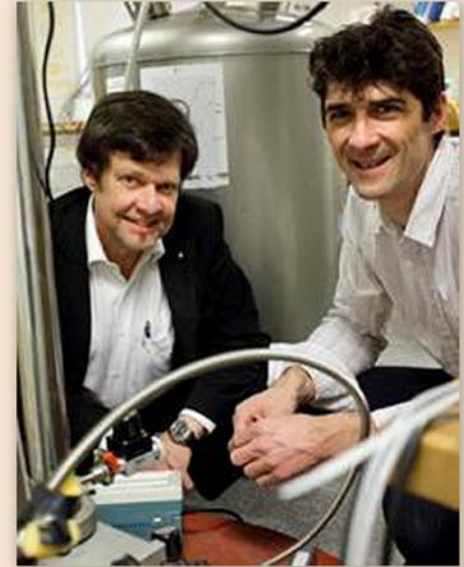

Lars Samuelson and Heiner Linke.

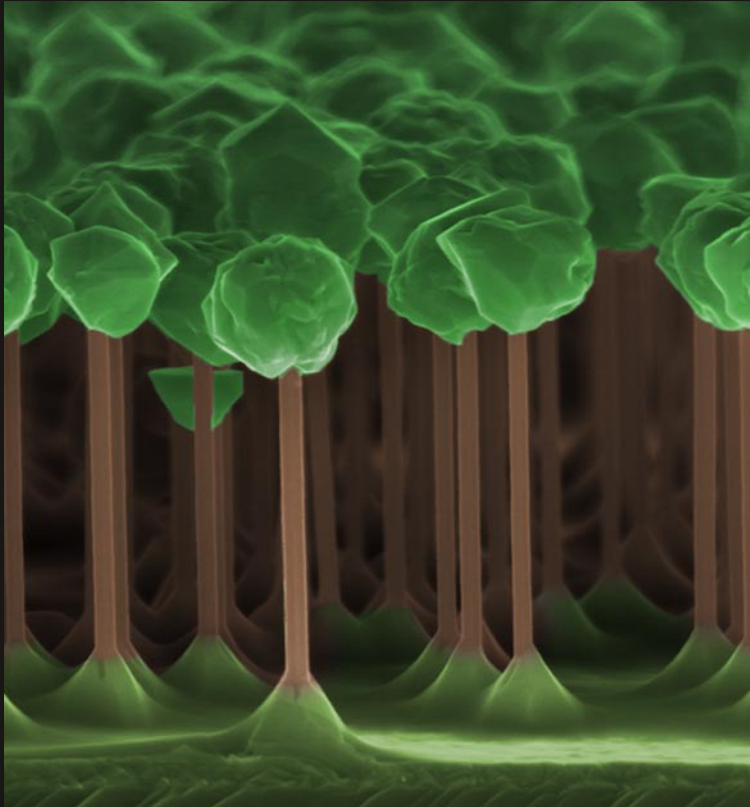

Nanotechnology

The growth of
the nano concept in Lund.

The nanotechnology in Lund

Lars Samuelson, Professor in Semiconductor Electronics at the Division of Solid State Physics, started the Nanometer Consortium (NMC) in 1990.

This consortium brought together chemistry, physics electronics and theory for the development of new physics, technology and materials science on the nanometre scale.

(1 nanometre, $1 \text{ nm} = 10^{-9} \text{ m}$)



Aerosols and Solid State Physics

One example of the interdisciplinary projects being carried out at the NMC is that with the Aerosol Group at the Division of Nuclear Physics.

It was shown that semiconductor structures could be made using size-selected aerosol particles. This project, which is led by Knut Deppert, has been very successful.

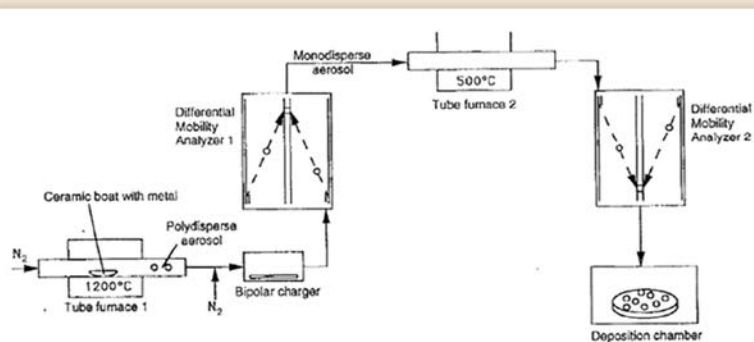
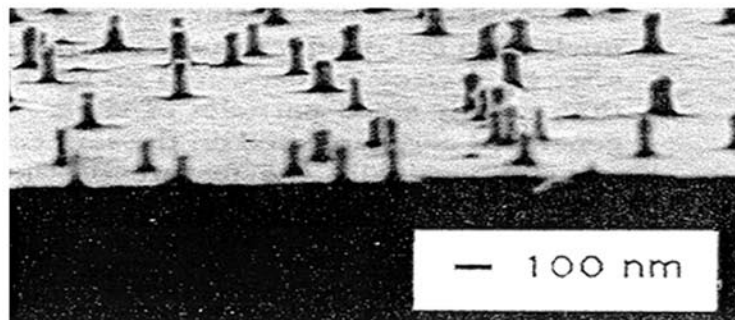

Illustration of the aerosol generation system in which nanoparticles with a narrow size distribution are made and deposited in a controlled way onto a substrate.



Scanning electron microscopy image showing freestanding columns of indium phosphide after an indium phosphide surface covered with silver particles has been etched.

Quantum dots

Fabrication of quantum devices by Ångström-level manipulation of nanoparticles with an atomic force microscope

T. Junno,^{a)} S.-B. Carlsson, Hongqi Xu, L. Montelius, and L. Samuelson
Solid State Physics/Nanometer Structure Consortium, Lund University, S-221 00 Lund, Sweden

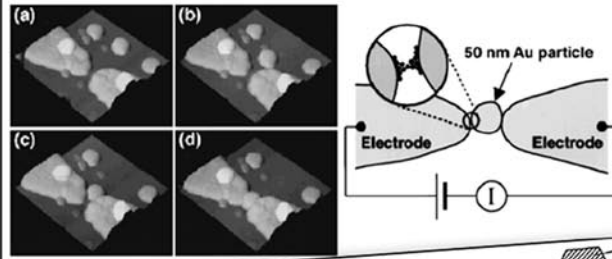

IN-SITU GROWTH OF QUANTUM DOT STRUCTURES BY THE STRANSKI-KRASTANOW GROWTH MODE

Werner Seifert,^{a)} Niclas Carlsson,^{a)} Mark Miller,^{a)}
 Mats-Erik Pistol,^{a)} Lars Samuelson^{a)} and
 L. Reine Wallenberg^{b)}

^{a)}Department of Solid State Physics, and ^{b)}Department of Inorganic Chemistry 2,
 Lund University, Box 118, S-221 00 Lund, Sweden

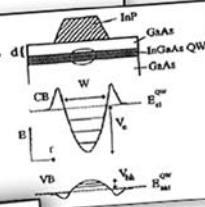

Optical Studies of Individual InAs Quantum Dots in GaAs: Few-Particle Effects

L. Landin, M. S. Miller,^{*} M.-E. Pistol,[†]
 C. E. Pryor, L. Samuelson

262

SCIENCE • VOL. 280 • 10 APRIL 1998

Using the method of MOVPE, quantum dots were made during the 1990s. These are small semiconductor structures in which the electrons cannot move in space, but can only be found in different energy levels.

Quantum dots are interesting in many fields such as optics and quantum components, as well as in theoretical research.

Magnets

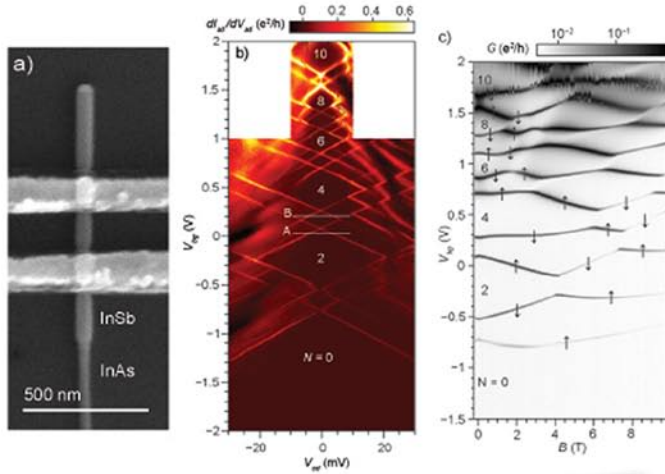

Spintronics

PHYSICAL REVIEW B
Zeeman study of the orthorhombic FeIn pair center in silicon
Mats Kleverman and Per Tidlund
Solid State Physics, Department of Physics, University of Lund, Box 118, S-221 00 Lund, Sweden
15 DECEMBER 1997-11
VOLUME 56, NUMBER 24

During the 1990s, many successful experiments were carried out at the division in which magnetic fields were used to split spectral lines using the so-called Zeeman effect.

After this, researchers at the division started using magnetic fields to investigate the magnetic characteristics of electrons in spintronics, a completely new field of special interest in logic circuits.

Ratchets

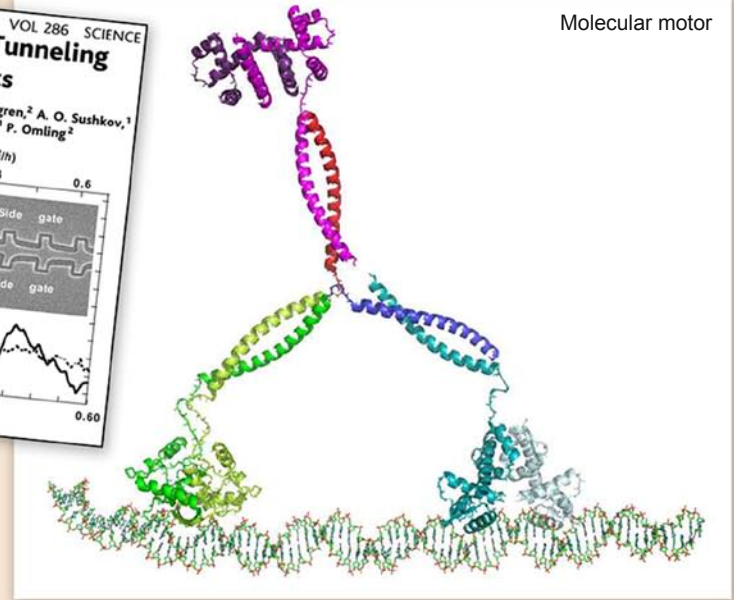
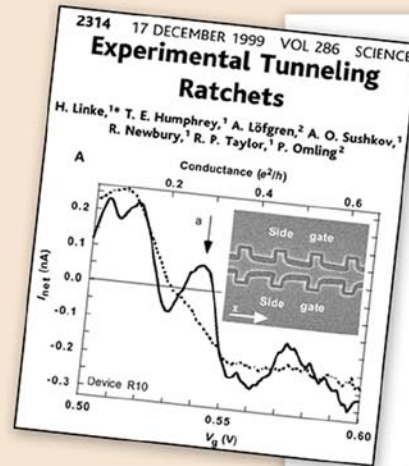

At the end of the 1990s, nanostructures called ratchets were made, which allow electrons to move in one direction only. In this way it is possible to control the flow of particles.

The division also started to carry out research in biology, and the Bio Group has made ratchets from proteins. These move along a DNA molecule in one direction, forming a so-called molecular motor.

Nanowires & Solid State Physics

In 1995, Lars Samuelson visited a research department at Hitachi in Japan, where they had been successful in growing nanowires of gallium arsenide.

Lars realised that resources were available in Lund to develop this technique, and upon his return he started work in this field.

		IIIA	IVA	VA	VIA
		Boron B 5	Carbon C 6	Nitrogen N 7	Oxygen O 8
		Aluminum Al 13	Silicon Si 14	Phosphorous P 15	Sulphur S 16
IB	IIB	Gallium Ga 31	Germanium Ge 32	Arsenic As 33	Selenium Se 34
Copper Cu 29	Zinc Zn 30	Indium In 49	Tin Sn 50	Antimony Sb 51	Tellurium Te 52
Silver Ag 47	Cadmium Cd 48	Thallium Tl 81	Lead Pb 82	Bismuth Bi 83	Polonium Po 84
Gold Au 79	Mercury Hg 80				

Part of the periodic table. The blue-highlighted elements are those mainly used at the Division of Solid State Physics to make semiconductors.

Nanowires

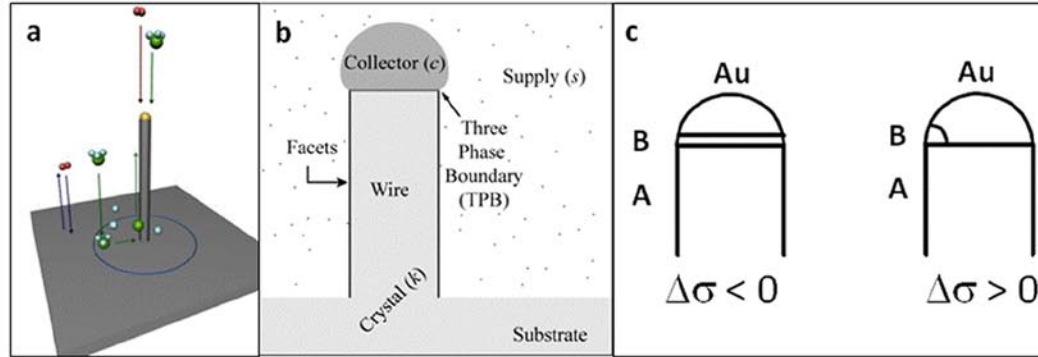

Nanowires are typically about 1 - 2 micrometres (μm) long and about 20 - 200 nm in diameter. They usually consist of two elements from groups III and V in the periodic table, but there are examples of combinations of elements from groups II and VI, alloys of three or four elements, or only group IV elements. Gold is often used as the catalyst for growing nanowires.

Nanowires grow in importance

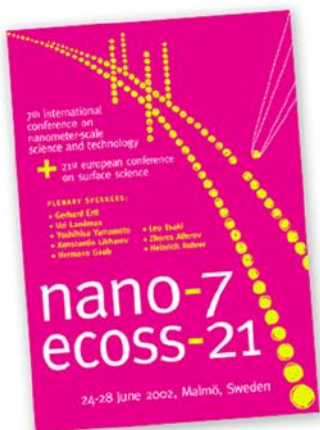
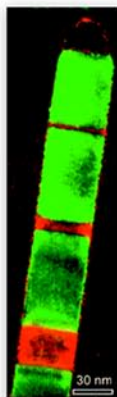
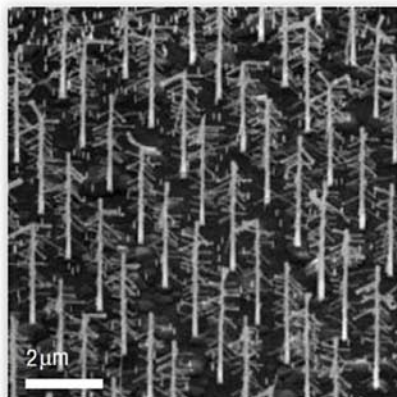

Nanowires now play a central role at the Division of Solid State Physics, and the day-to-day work of most research groups is influenced by nanowires.

Attention was directed towards Lund in 2002, as researchers here were able to grow nanowires with a heterogeneous structure, nanowires with segments of different materials, in this case indium phosphide and indium arsenide.

In the same year, the division organised the 7th Nano Conference.

In 2004 the division was also able to demonstrate the growth of *branches* on nanowires, forming *nanotrees*, and even whole *nanoforests*!

The degree in nanotechnology

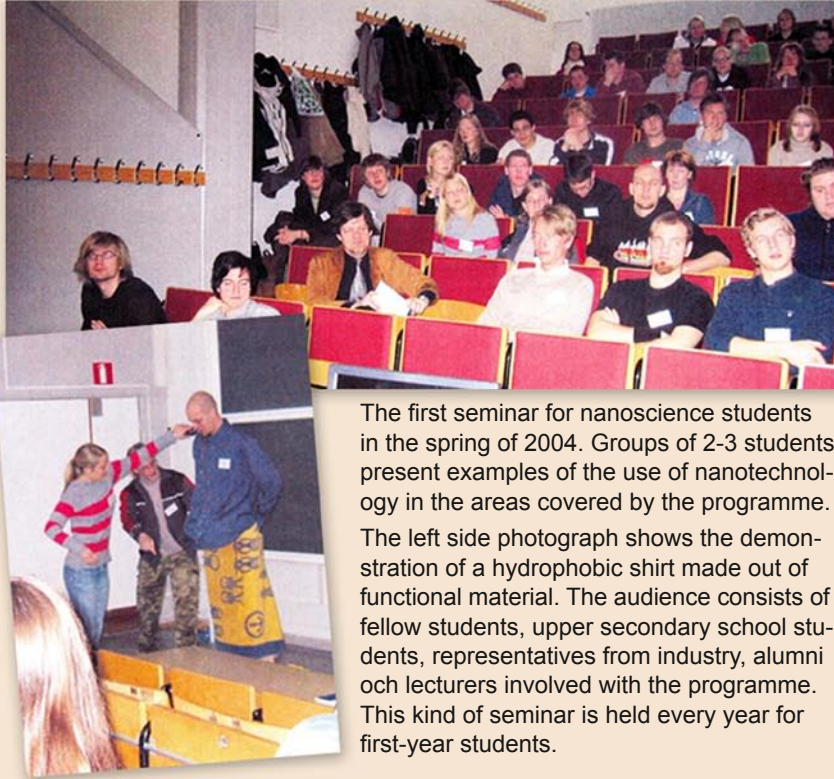

The first seminar for nanoscience students in the spring of 2004. Groups of 2-3 students present examples of the use of nanotechnology in the areas covered by the programme. The left side photograph shows the demonstration of a hydrophobic shirt made out of functional material. The audience consists of fellow students, upper secondary school students, representatives from industry, alumni och lecturers involved with the programme. This kind of seminar is held every year for first-year students.

The interdisciplinary nature of nanotechnology inspired Lars Samuelson to develop a research-based 4½-year programme in nanotechnology.

The first group of students enrolled in the programme for Engineering Nanoscience in 2003. The programme is mainly based on studies in materials science, physics, electronics and biology.

The Nanochurch

The expansion of the division led to a need for more space and new equipment. An extension was built onto the Berzelius Lab, which was completed in 2006/2007. As the shape of the building resembles a modern church, it has become known as *the nano church*.



As well as a new laboratory, the Nano church also includes an area for seminars, called *the Creative Space*, or K-space.



The cleanrooms

The nano church has several cleanrooms that house equipment for the growth of crystals and the fabrication and characterisation of nanostructures. The cleanroom with the highest classification is ISO class 5, which means that no more than 100,000 particles larger than $0.1\ \mu\text{m}$ are allowed per cubic metre.



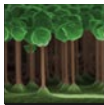

The beginning of the 21st century

Four main areas of research are currently being pursued at the division today:

Nanomaterials

Nanophysics

Nanodevices

Life sciences

The success of the NMC means that activities at the division extend far beyond the Nanochurch. The facilities at the Division of Solid State Physics are used by over 200 researchers from 20 divisions of 11 departments, both within and outside Lund University.

A programme for commercialisation has led to the foundation of several spin-off companies and engagement in a number of EU projects.



The scanning electron microscope is an important tool in the study of nanostructures.

Nanomaterials

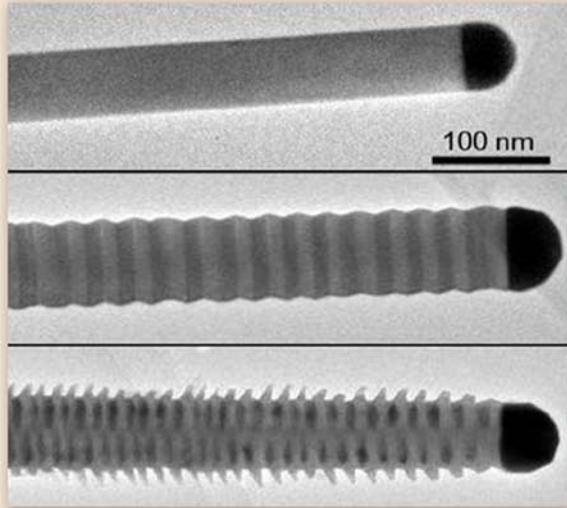

Nanowires with and without a heterogeneous structure.

Research in nanomaterials includes materials science, crystal growth and nanostructure fabrication.

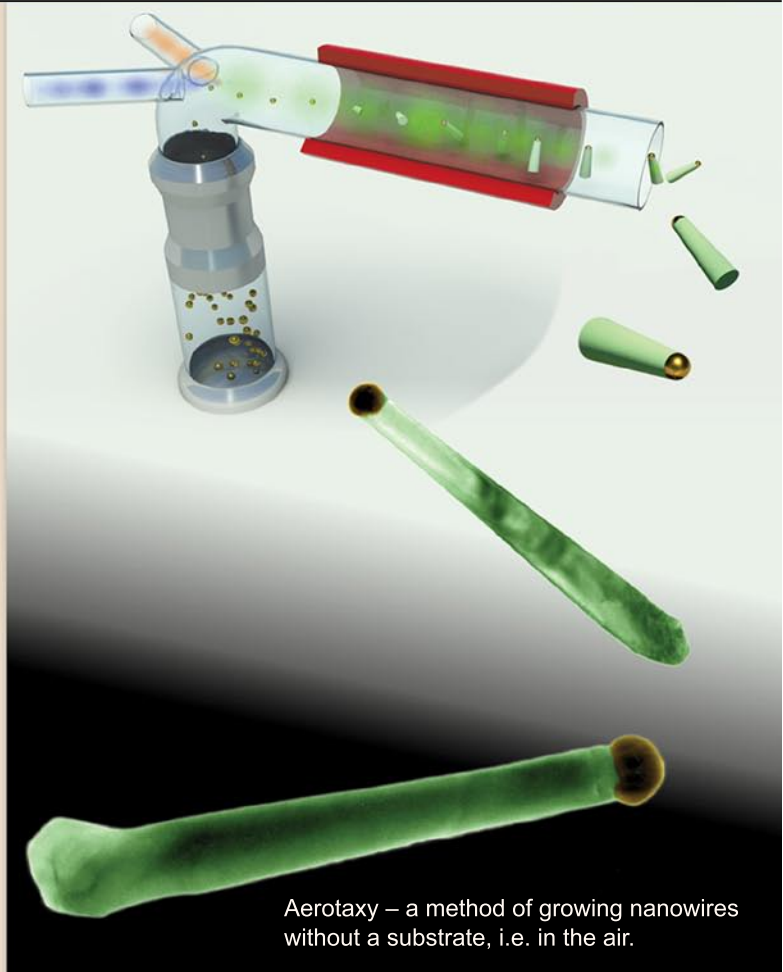

Aerotaxy – a method of growing nanowires without a substrate, i.e. in the air.

Nanophysics

Research in the field of nanophysics includes quantum transport and optical physics.

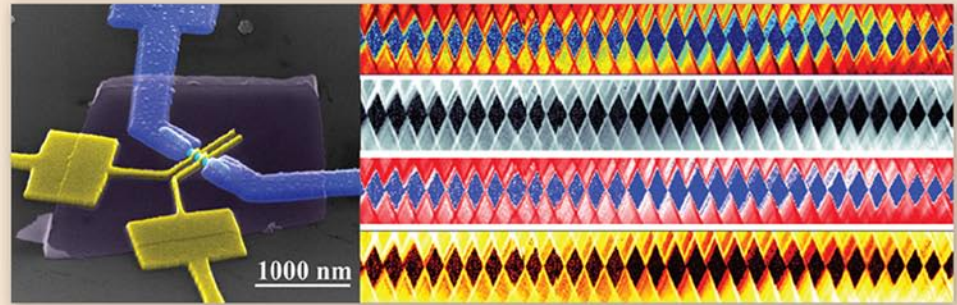

Electron transport in nanostructures includes the search for Majorana fermions and studies of Coulomb diamonds.

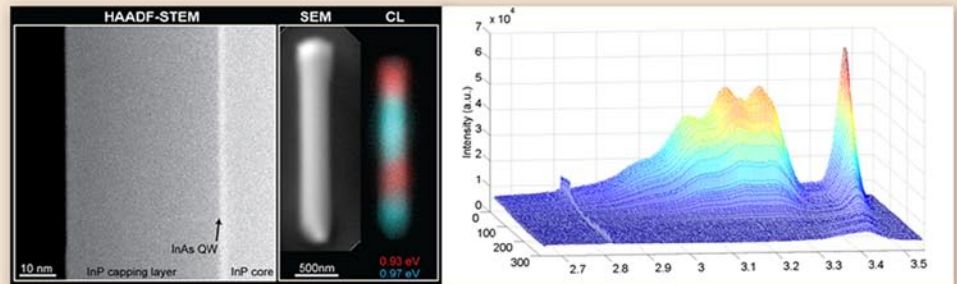

Photoluminescence. This method gives high spectral resolution for the optical characterisation of semiconductor materials.

Nanodevices

Research in the field of nanodevices includes nanoelectronics and optoelectronics.

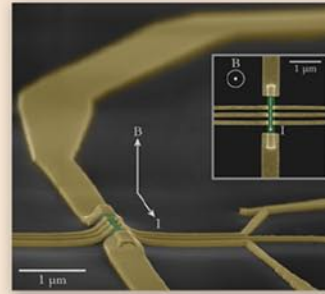

The Hall effect in a single nanowire.

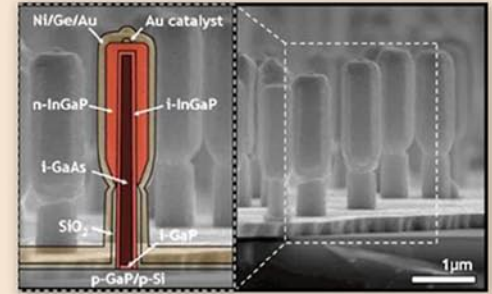

LEDs and on-chip optoelectronics.

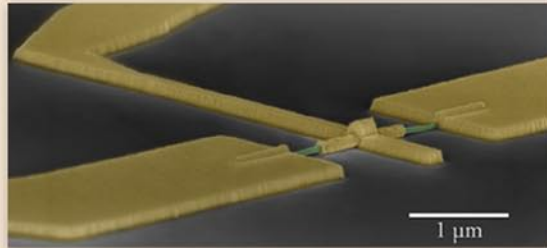

Transistors

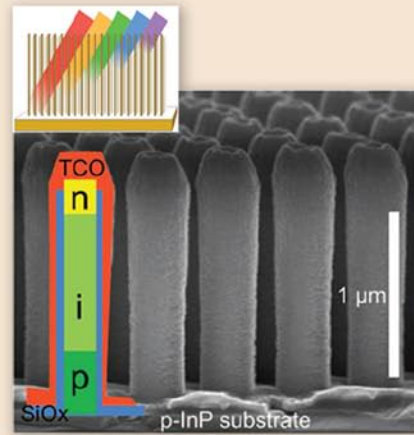

Solar cells

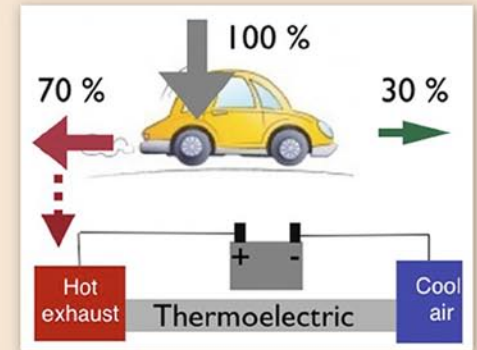

Thermoelectricity



Life sciences

Research in the field of life sciences includes nanobiophysics and nanosafety.

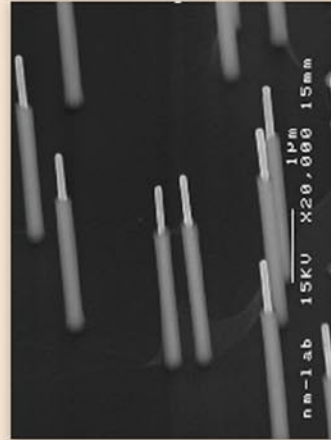

Biosensors (nanowire electrodes) for detecting interactions with nerve cells.

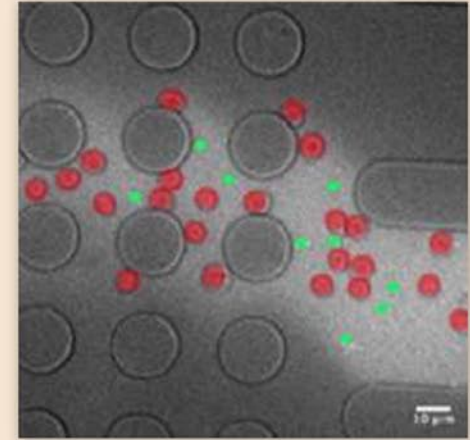

An example of a *lab on a chip* used here to sort particles. The figure shows a so-called *bumper array*, which sorts particles according to size and shape based on the path they take through the device.

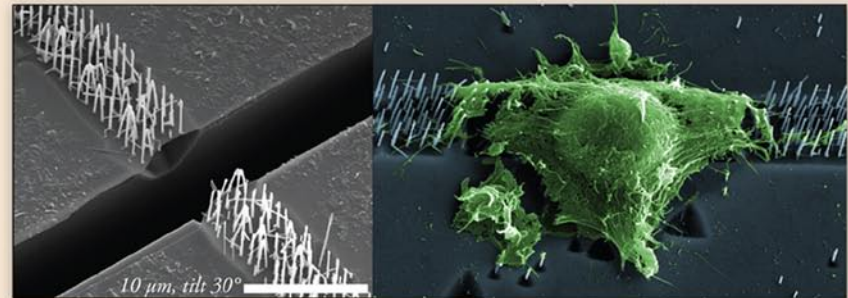

Hollow nanowires for the injection of cells.

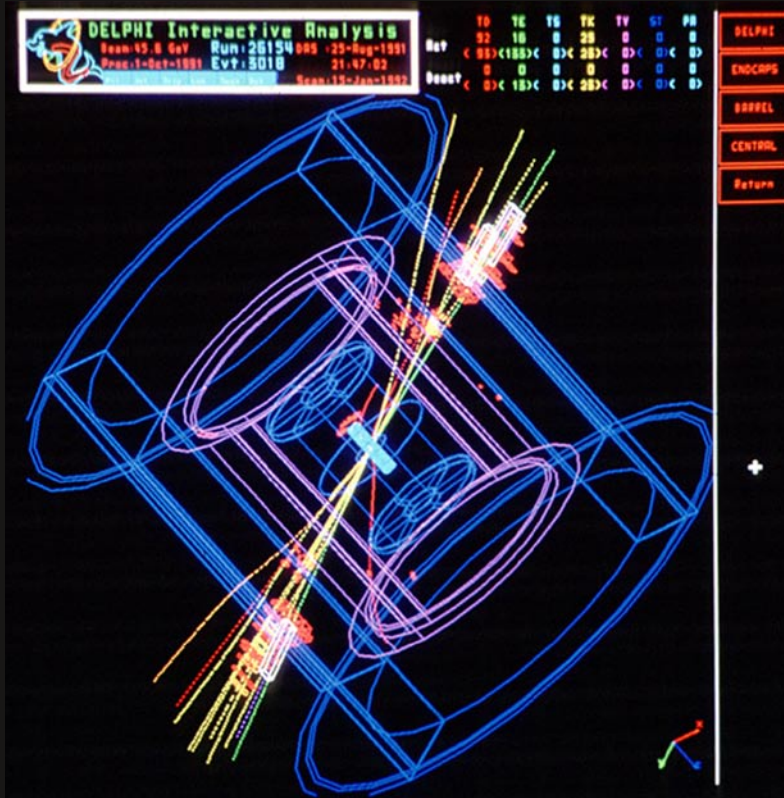

Exploring the microcosmos

How physicists in Lund measured a new scattering effect, helped determine the number of families of leptons and quarks, and took part in the hunt for the Higgs particle.

What we know, and what we want to know

We know, today, that the three main forces of nature, the electromagnetic, the weak and the strong force, can be described with the aid of field theories, but can gravity be described by a field theory, and are the most elementary particles in that case strings?

What is dark matter and what is dark energy?
Why is there only matter and not antimatter?
Do the forces of nature have a common origin?

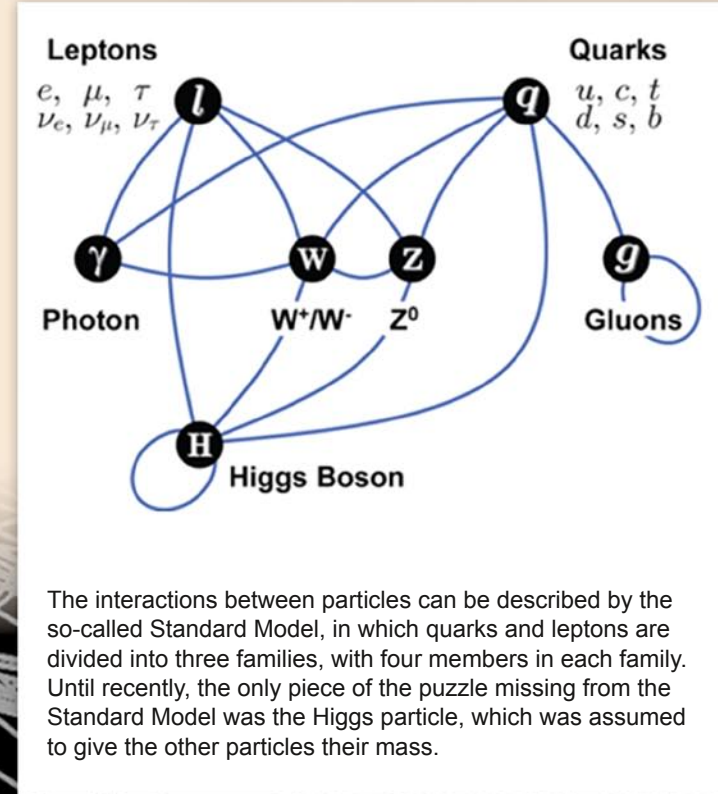

The transformation of particle physics

Particle physicists study the smallest building blocks of matter and the interactions between them. Experimental particle physics started in Lund in 1962, when the first parts of an accelerator built at KTH (The Royal Institute of Technology) arrived in Lund.

It was Professor Sten von Friesen who was successful in getting the 1.2 GeV electron accelerator located in Lund, rather than Uppsala.

The Lund University Electron Synchrotron, or LUSY as it was known, paved the way for MAX-lab, and with it a completely new research division at the Department of Physics.

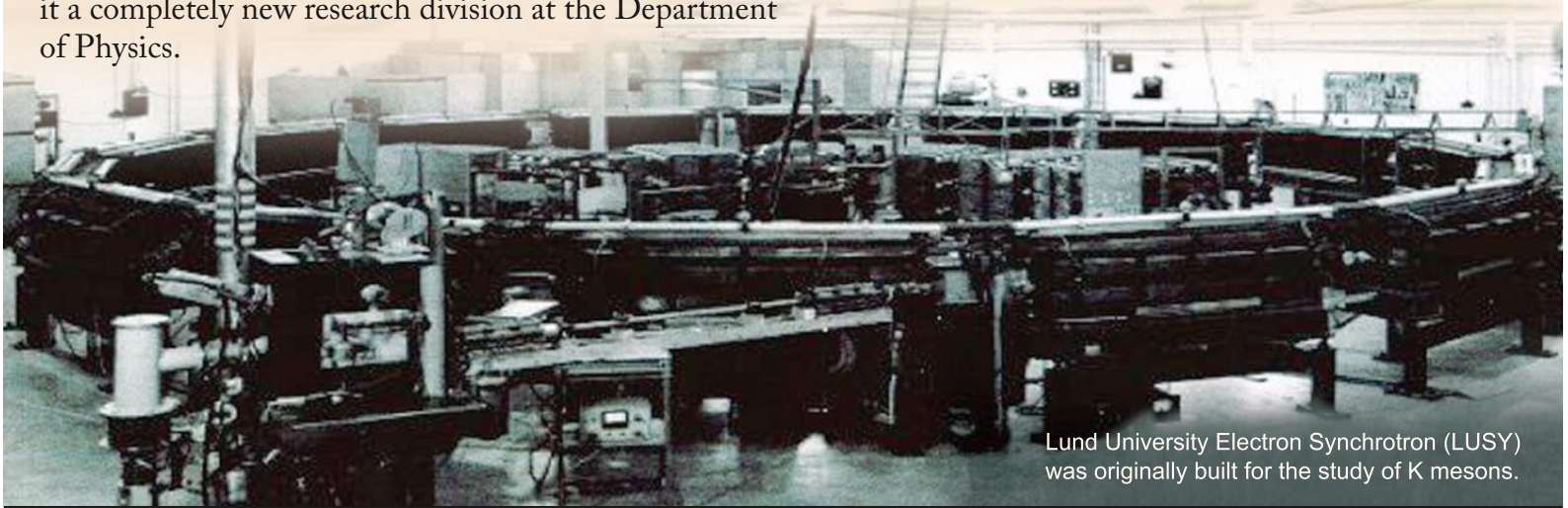
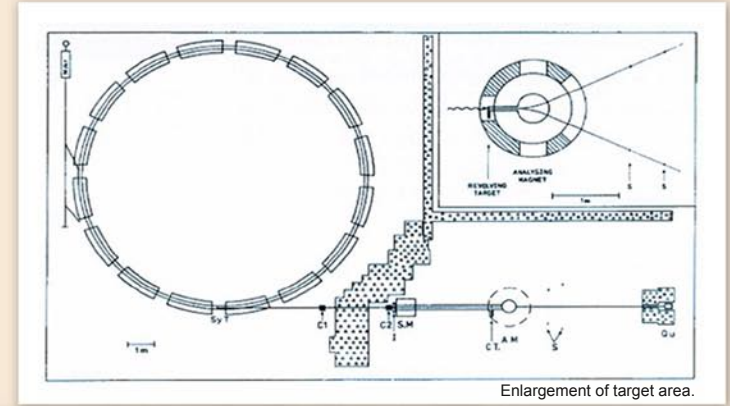

Lund University Electron Synchrotron (LUSY) was originally built for the study of K mesons.

Professor Guy von Dardel

Guy von Dardel became Professor of Elementary Particle Physics in Lund in 1965. He was born in Stockholm and, after obtaining his doctorate at KTH in 1954, took part in the construction of the world's largest particle research facility, CERN in Switzerland. He coordinated the development of the instrumentation for several experiments and, amongst other things, performed renowned measurements of the lifetime of the neutral pi-meson (π^0), which were of great importance for the understanding of the nature of the strong force.



Guy von Dardel 1919 - 2009

CERN

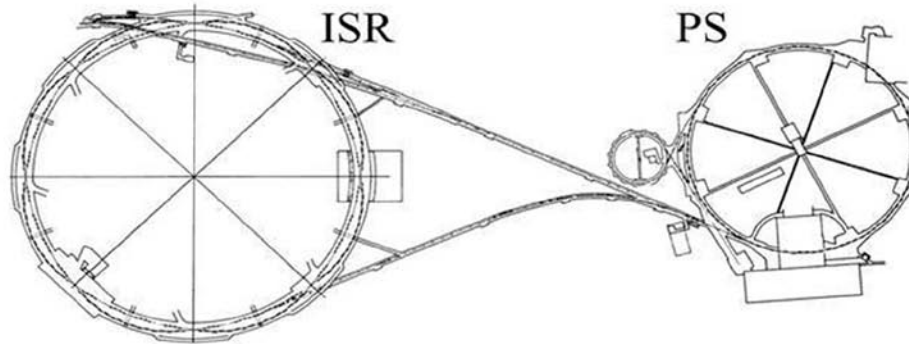

Protons from the PS are led into the ISR where they circle in two rings which cross each other at eight points.

CERN was founded in 1954 by 12 European countries, among them Sweden, and its development is directly related to the history of its accelerators and storage rings.

The first accelerator, a proton synchrotron (PS) with a circumference of over 600 metres, came into operation in 1959.

As high energies are needed to study the interaction of elementary particles, this field of physics is often called high-energy physics. A significant step forward in terms of energy was taken in 1971 when the world's first storage ring for protons, the Intersecting Storage Ring (ISR), was completed. This made it possible to test the quark model.

Lund makes its mark on CERN

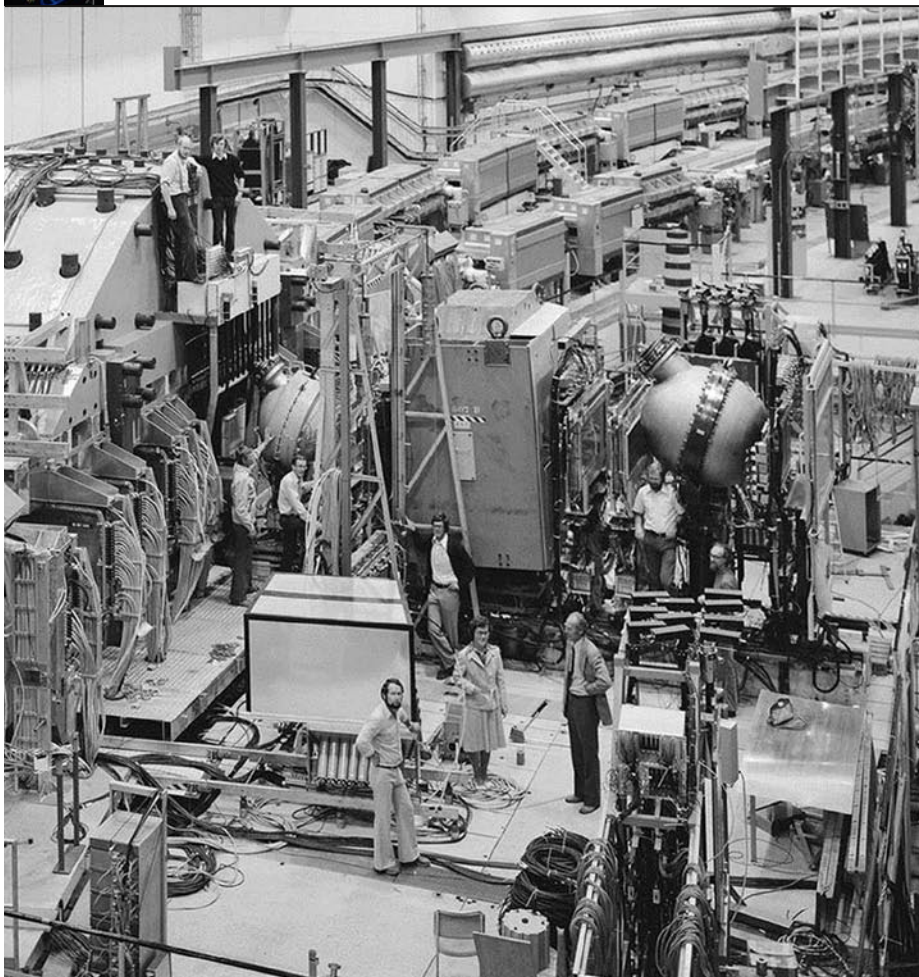

Guy von Dardel established a Scandinavian research group at the new proton-proton collider (the ISR) at CERN. During a period of over ten years, they studied the properties of the strong force, or quantum chromodynamics (QCD).

They were especially interested in how quarks manifest themselves as showers of correlated particles, so-called jets, the subject of Torsten Åkesson's PhD thesis.

In another experiment carried out by Lund physicists, observations that were made showed that the number of quarks and gluons increased as their momentum decreased.

Intersecting Storage Ring (ISR) at CERN, where the highest collision energy of the day was achieved (63 GeV). The technical resources in Lund were good, and the group, which can be seen in the photograph, contributed to the construction of the instrumentation for the ISR experiments.

The Delbrück experiment

In 1969, the accelerator in Lund, LUSY, paved the way for an interesting experiment. Two young physicists, Göran Jarlskog and Leif Jönsson, happened to see a theoretical paper by H Cheng and TT Wu on Delbrück scattering. Jarlskog applied to DESY in Hamburg, Germany to carry out an experiment. His application was accepted and the results showed that Cheng and Wu had to extend their calculations to include multiphoton exchange to obtain agreement with the experimental data.

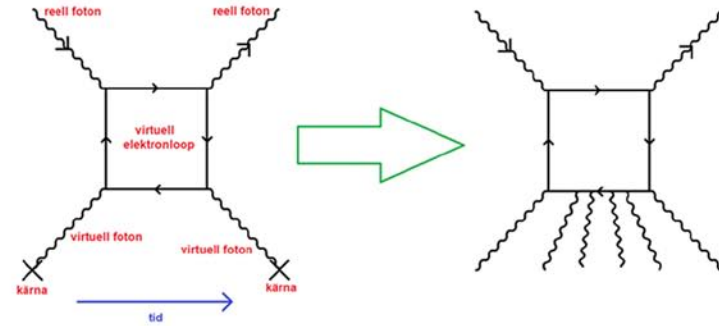

First-order diagram with an incoming real photon, which is split into a virtual electron-positron pair, which in turn couples to the core via virtual photons at the points marked X. In the final state a real photon is recreated.

Diagram illustrating multiphoton exchange.

From ISR to LEP

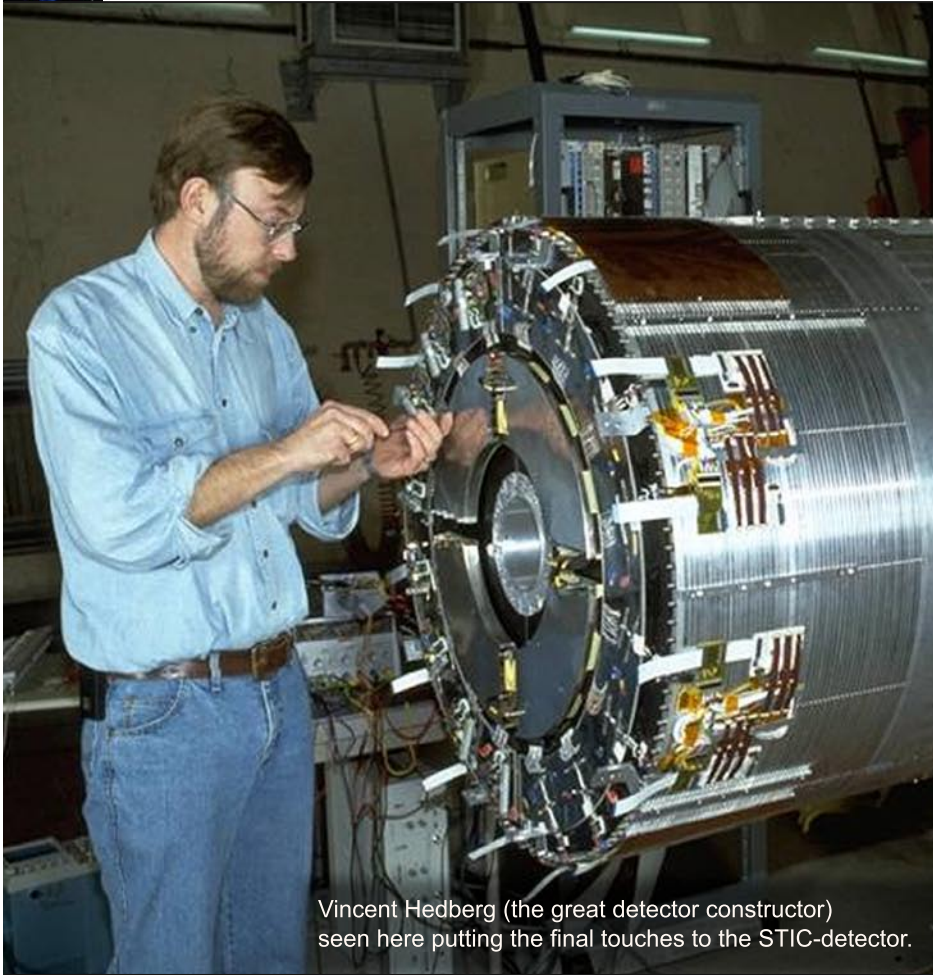

Vincent Hedberg (the great detector constructor) seen here putting the final touches to the STIC-detector.

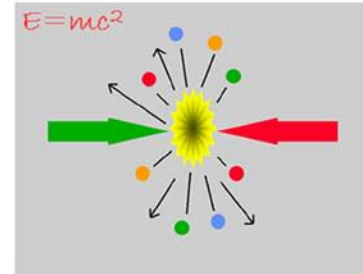

The conversion of energy to mass, according to Einstein's famous equation.

CERN changed direction, and in 1988 experiments started using the large electron-positron collider (LEP), in which the collision energy is known when an electron and a positron annihilate.

This accelerator was built to study the electroweak force in detail, and the properties of the W and Z particles in particular. When electrons and positrons collide, they annihilate, releasing energy. Some of this energy is converted into new particles, which can be studied in a detector.

LEP & DELPHI

The large electron-positron collider (LEP) in CERN was the world's most advanced in the 1990s. In the 27 km long underground ring, electrons and positrons could be accelerated to energies above 200 GeV, providing extremely good conditions for new discoveries.

The group from Lund contributed to the construction of the successful DELPHI experiment, where they were involved from the beginning thanks to Göran Jarlskog who succeeded Guy von Dardel as professor in Lund in 1987.

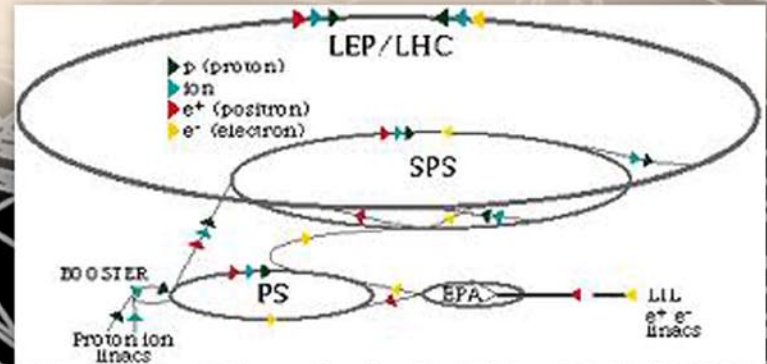

Detector construction in Lund



An event showing $Z \rightarrow qq(-)$.
The quarks are converted into showers of hadrons (jets).

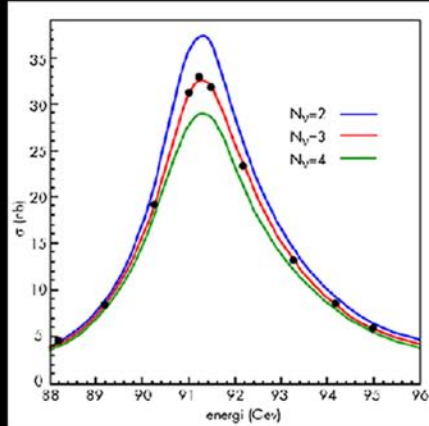

Measurements of the resonance width of the Z particle compared with predictions for 2, 3 and 4 families. The experimental data are consistent with 3 families, each including a neutrino.

The Lund group was active in this fundamental discovery.

DELPHI was the name given to an experiment carried out during the 1990s at the LEP, in which Lund took part in the design of the central track detector.

Some of the most important events were the measurement of the width of Z bosons (which gives the number of families of quarks and leptons), tests of the predictions of the Standard Model regarding the electroweak and strong interactions (where all the present results support the model), and the unexpectedly high lower limit for the mass of the Higgs particle (114 GeV).

Lund's involvement at DESY

Evidence of the existence of a new particle, the ypsilon particle (Y), were obtained with the proton accelerator at Fermi Labs in Chicago, USA.

The DORIS collider at DESY in Hamburg was used to study the charge on the particle, as this was the only accelerator with sufficiently high energy to study this newly discovered quark-antiquark state.

Physicists from Lund were invited to take part in the over 15-strong research group formed in 1977. Only one year later, 1978, it was confirmed that the Y particle was indeed a bound quark-antiquark pair with a charge of $-1/3$.

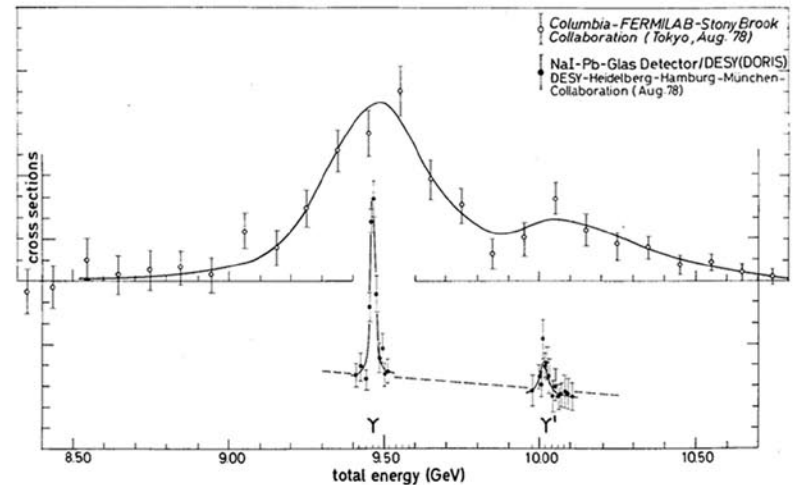

This figure shows the two lowest mass states of the Y particle, and illustrates the difference in resolution between a proton accelerator (above) and an electron-positron collider (below).



Leif Jönsson was responsible for the Lund group's participation in the research at DESY.

Matter and antimatter

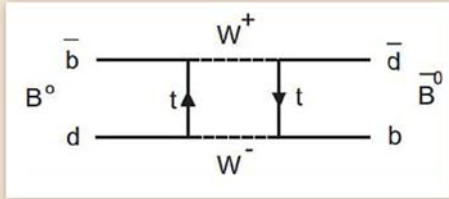

A Feynman diagram of the transition between matter and antimatter.

$$e^+e^- \rightarrow \bar{B}^0 \rightarrow \text{oscillation} \rightarrow B_1^0 \bar{B}_2^0 \rightarrow \pi_1^+ K_1^+ \pi_1^- \mu_1^+ \nu_1^- \quad K_2^+ \pi_2^+ \pi_2^- \pi_0^0 \mu_2^+ \nu_2^-$$

The first detected event in the observation of the transition from matter to antimatter.

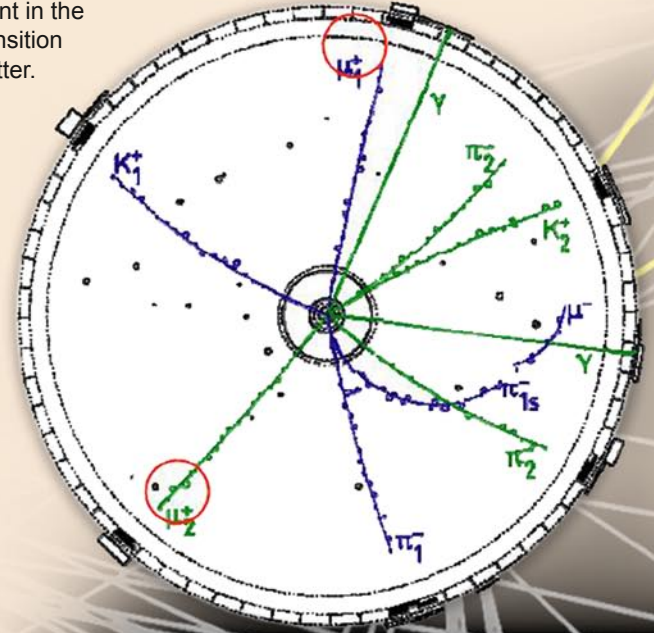

At the same time as the DESY group was formed, plans were also started for a new detector, ARGUS. It was ready to provide its first data in 1982, and allowed studies of phenomena in the energy range 3-10 GeV.

The detector was in use for more than ten years, and provided data for many important discoveries, the most important being the discovery of the oscillations between B mesons and anti-B mesons, i.e. transitions between matter and antimatter.

Looking into the proton

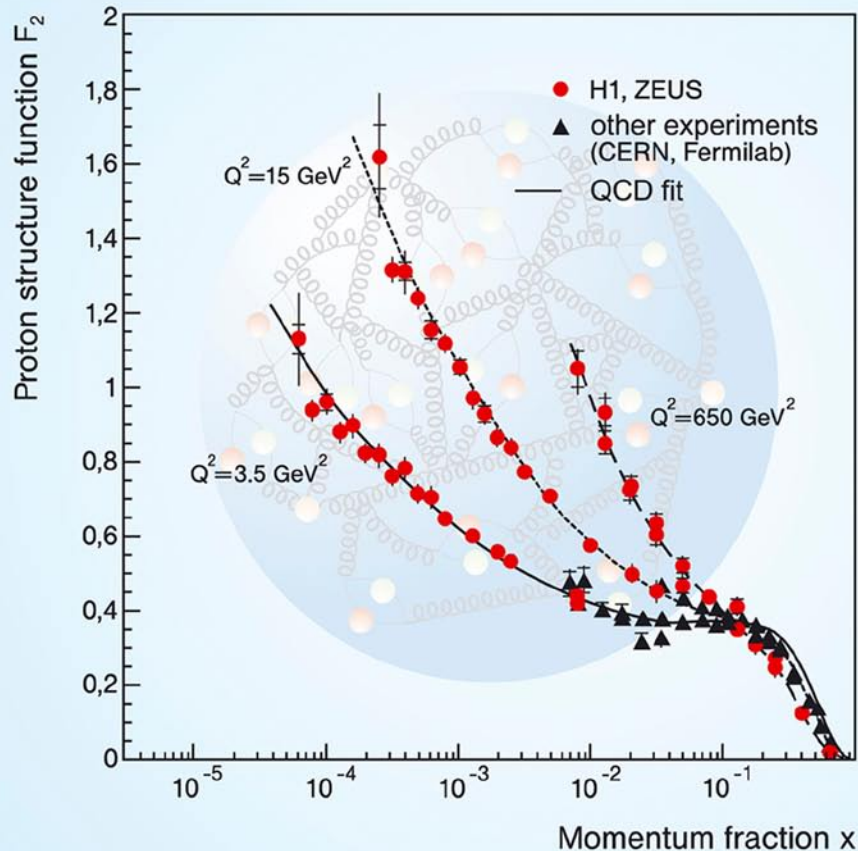

In 1992, the HERA collider at DESY was ready to produce their first collisions to study the inner structure of the proton.

The Lund group was, together with others, the first to make direct measurements of the momentum spectrum for the gluons in a proton.

Together with the theoretical group from Lund, a model was constructed describing quark dynamics, making Lund world leaders in the field.

A unique discovery was made in 1993, which confirmed the measurements previously made at ISR, in which clear indications were seen that the number of partons (quarks and gluons) in the proton increased as their momentum decreased.

The hunt for the Higgs particle

In the Large Hadron Collider (LHC), which came into operation in 2009, protons can be collided with each other, producing a maximal collision energy of 14000 GeV, which should be more than sufficient to see beyond the Standard Model.

LHC started in September 2008, but collapsed after a week. At the relaunch November 29, 2009, one was very excited.

The LHC at CERN seen from above.



Finally!



The reaction of particle physicists when the Large Hadron Collider was started up on 29 November 2009.

ATLAS

The largest detector system at CERN is called ATLAS, and is the result of worldwide collaboration between 38 countries. It was built with the aim of finding the final piece of the particle puzzle. The Lund group's participation is being led by Torsten Åkesson, who was also the mainstay of the group that first proposed the building of the LHC.

In June 2012 a great breakthrough was made at the ATLAS detector, when experiments showed that the famous boson, Higgs particle, almost certainly exists.

The search for the Higgs particle gave results and on the 4th of July 2012, there were clear evidence of the particle's existence.

The ATLAS detector

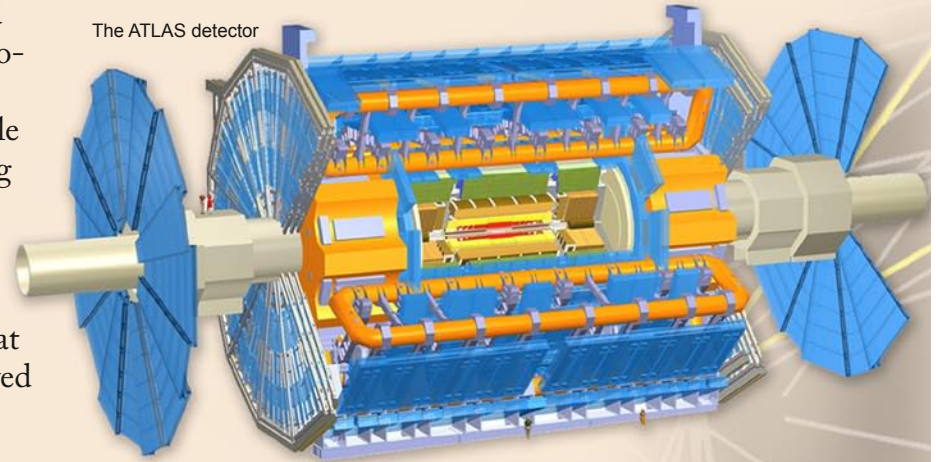

Torsten Åkesson is the director of the Division of Particle Physics at the Department of Physics, Lund.

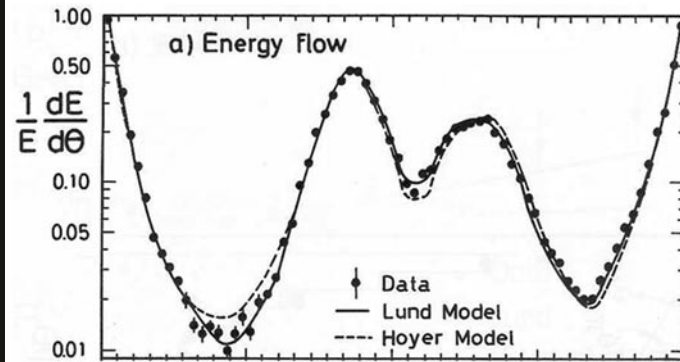

The Lund model for high energy collisions

The famous Lund model – theoretical ideas meet experimental reality.

Historical background



M Gell-Mann



Yoishiro Nambu

During the 1930s it was known that matter consists of atomic nuclei (protons and neutrons) with electrons orbiting around them. During the 1940s and 50s many other particles were discovered, called hadrons, that appeared to be as elementary as protons and neutrons. These hadrons interact with each other via the strong nuclear force.

In 1964, M Gell-Mann and G Zweig independently introduced the hypothesis that hadrons are made up of even smaller particles, called quarks. Y Nambu suggested that quarks come in three varieties, colours, which interact via the exchange of gauge bosons, called gluons.



The observation of quarks

In 1968, an experiment was carried out at the linear accelerator center in Stanford USA (SLAC) in which 20 GeV electrons were scattered off protons. The results were similar to those obtained in Rutherford's experiment where a gold target was bombarded with alpha particles, showing the existence of a dense nucleus. The results of the SLAC experiment were interpreted as showing that the electrons had been scattered by smaller constituents in the protons.

In 1974 a particle was discovered that contained a new quark, the charm quark, which had been predicted by the quark theory. Thereafter, a majority of physicists considered that the quark hypothesis was probably correct.

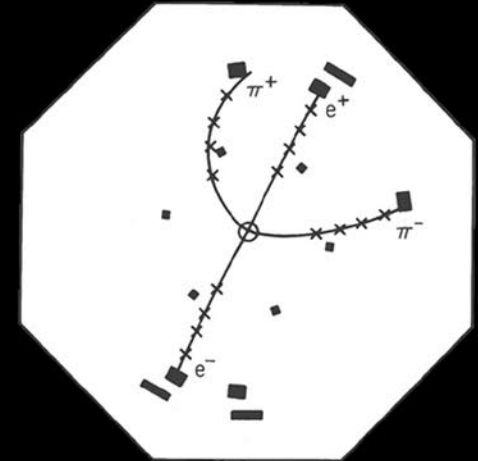

Tracks from a J/ψ meson, which decays to two pions (π^+ , π^-), an electron (e^-) and a positron (e^+). The J/ψ meson consists of a charm quark and its antiquark.



The linear accelerator at Stanford, USA, where experiments showed that a proton is made up of quarks.

Quantum chromodynamics – QCD

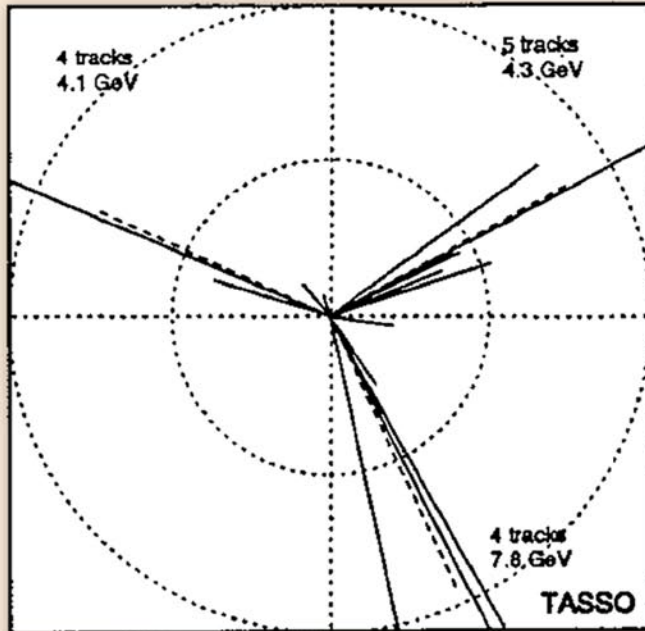
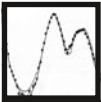

Figure from the TASSO experiment at DESY in Hamburg, which demonstrated the existence of gluons, thereby confirming the theory of QCD. The figure shows three particle showers from a quark, an antiquark and a gluon created by the collision between an electron and a positron.

In 1972, a consistent hypothetical theory for strong interactions, quantum chromodynamics (QCD), was formulated based on Gell-Mann's and Nambu's ideas of coloured quarks and massless gluons.

The theory was confirmed in 1979 when the existence of gluons was demonstrated in electron-positron collisions.

The equations governing QCD can, however only be solved when the quarks or gluons are very close to each other. In other cases, QCD-inspired models are required.



The beginning



Bo Andersson

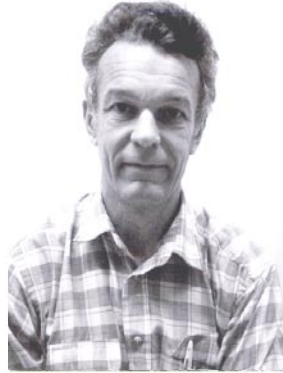

Gösta Gustafson

When Gunnar Källén came to Lund in 1958 he assembled a lively group of postgraduate students who studied field theoretical problems. When Källén died in 1968, his students were dispersed all over the world.

In the mid 1970s, there was increasing evidence that quarks formed the basis of all matter. Bo Andersson and Gösta Gustafson, who had then returned to Lund, together with the PhD student Carsten Peterson decided to study what was for them a new area. This was the start of what was later to become the Lund Model.



Early development

Carsten Peterson obtained his doctorate in 1977, and left Lund soon after. He was replaced by several other talented PhD students. Torbjörn Sjöstrand, Bo Söderberg, Gunnar Ingelman and, somewhat later, Hans-Udo Bengtsson, made especially important contributions to the quark project. Efforts were directed to understanding and describing high-energy collisions.

The Lund Model and the Lund Monte Carlo program became the terms used for models and computer programs used to simulate various kinds of collisions between electrons, protons and nuclei. String fragmentation and quark-gluon cascades are important components in these models and programs.

Results from a study by Andersson, Gustafson, Ingelman & Sjöstrand, showing the angular distribution of energy of gluon emission in electron-proton collisions. The solid line shows the Lund Model prediction.

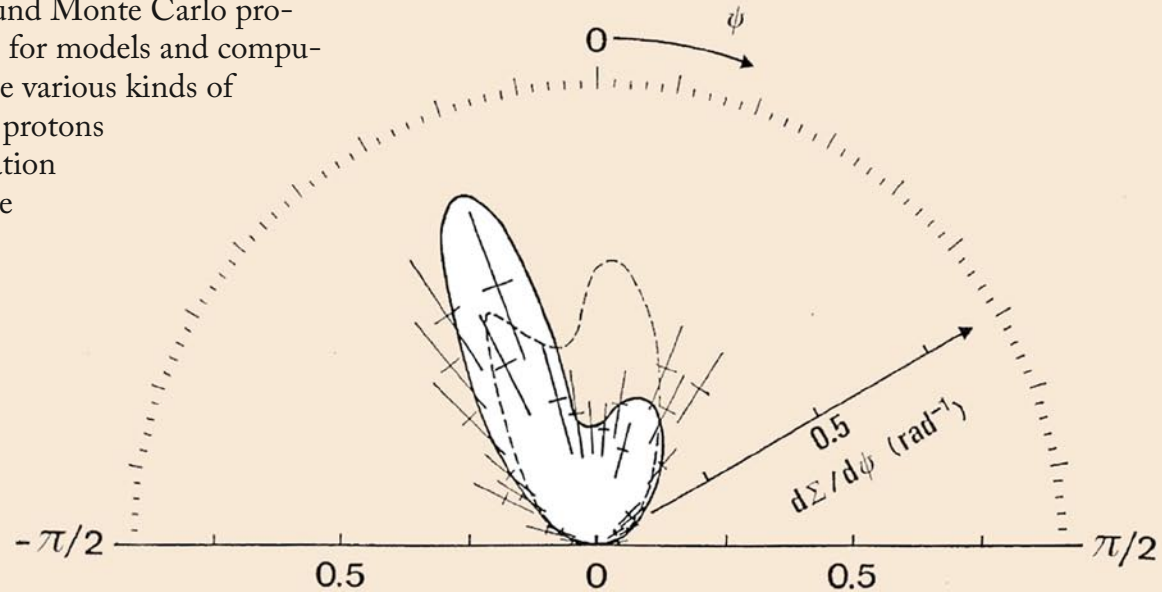

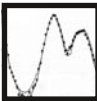

Quark fragmentation

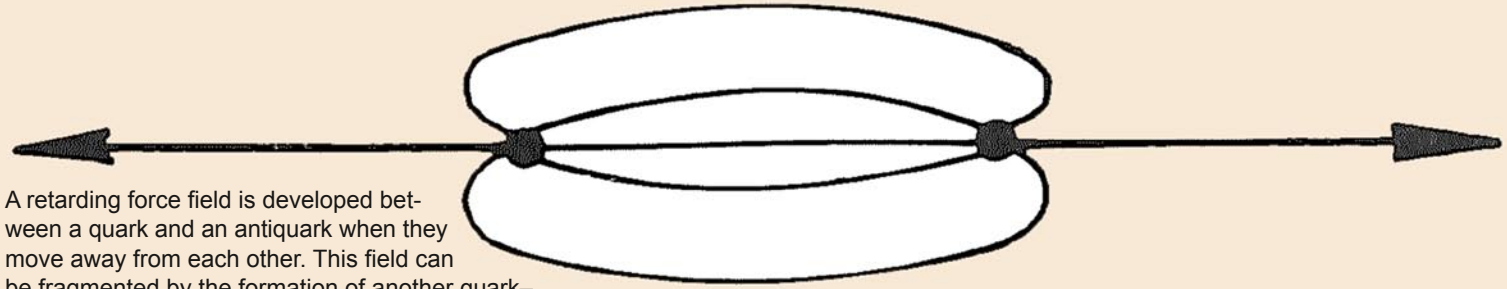

A retarding force field is developed between a quark and an antiquark when they move away from each other. This field can be fragmented by the formation of another quark–antiquark pair. Repeated fragmentation leads to several bound quark–antiquark systems. These are the observable particles in the showers, or jets, in the direction of the quark and the antiquark.

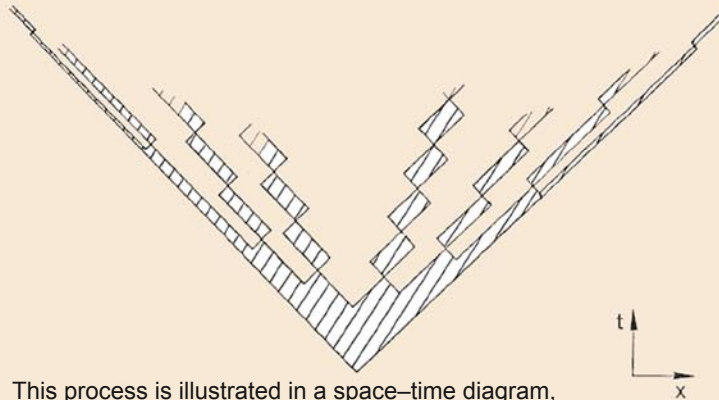

This process is illustrated in a space–time diagram, in which time extends upwards. The extension of the force field is shown by the hatched area.

In high-energy collisions between, for example, an electron and a proton, a quark can be ejected from the proton. However, as it cannot be isolated, it materializes as a shower or jet of hadrons (bound states in a quark–antiquark pair, or three quarks).

Similar jets arise from reactions where the electron–positron pair is transformed into a quark–antiquark pair. In 1977, an important step was taken with a model describing how the energy of a high-energy quark is transformed into such a jet.



Gluon fragmentation

The jet fragmentation model was refined and developed, and in 1979 was also able to describe gluon jet fragmentation (as a gluon with high energy also cannot be isolated, it similarly gives rise to a jet of hadrons). The force field that holds the particles together is assumed to be similar to a massless relativistic string, and the model is thus called the Lund String Fragmentation Model.

This model predicted a specific asymmetry in the particles produced in electron–positron collisions, and was widely acclaimed when this was observed experimentally in 1980.

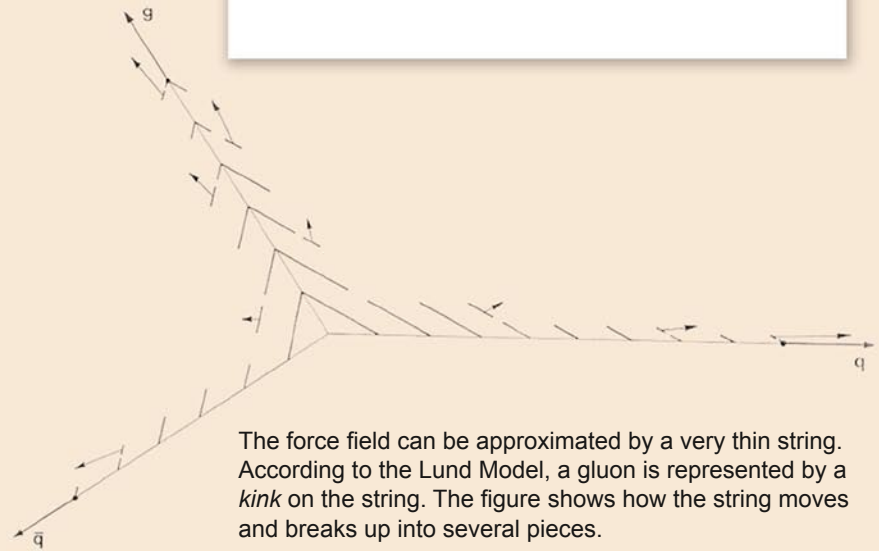
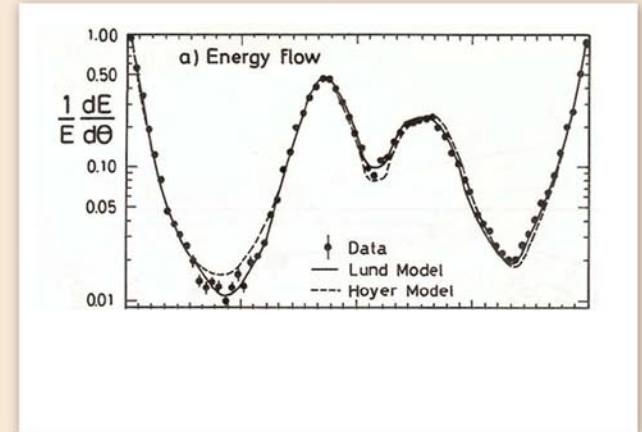

The force field can be approximated by a very thin string. According to the Lund Model, a gluon is represented by a *kink* on the string. The figure shows how the string moves and breaks up into several pieces.



Monte Carlo

A high-energy collision is so complex that it cannot be treated analytically. It was thus necessary to complement the models with simulation programs, generally called Monte Carlo programs.

The Lund MC program was developed to simulate collisions between all conceivable elementary particles and also atomic nuclei. Such simulations are used in both the planning of experiments and the analysis of the results.

The program PYTHIA, developed mainly by Torbjörn Sjöstrand, is particularly important, and is now the world's most commonly used program for high-energy collisions.

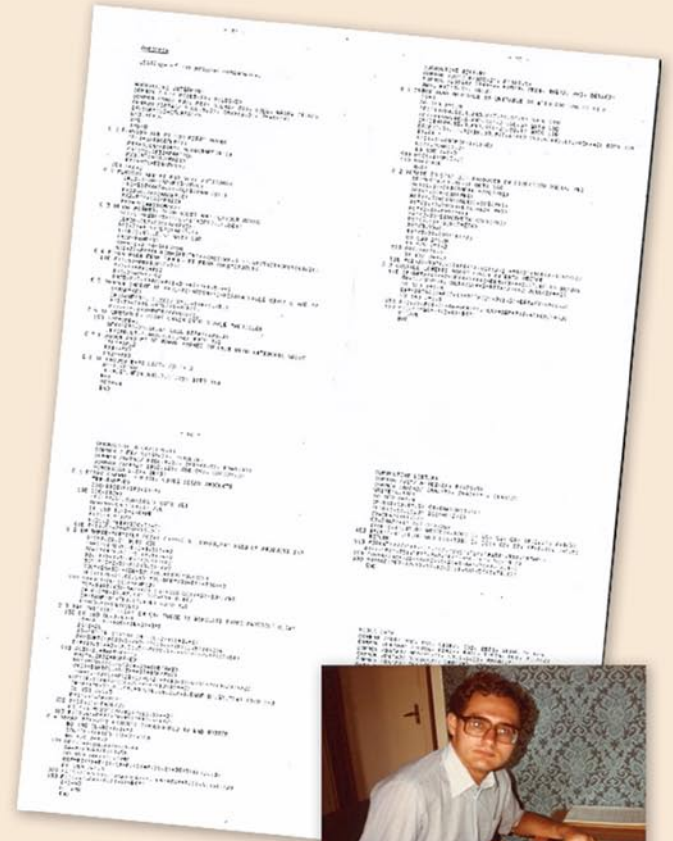

Torbjörn Sjöstrand

The first Monte Carlo program developed in 1978 was short enough to fit on one A4 page. Today's version (2014) contains about 100 000 lines of code.



Quark–gluon cascades

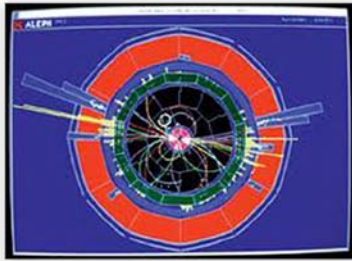

Electrons and positrons of high energy are collided in the Large Electron–Positron collider (LEP) at CERN. This leads to the formation of a quark, an antiquark and a large number of gluons. The production of these multigluon states is well described by the dipole formulation, which is simulated in the Monte Carlo program ARIADNE.

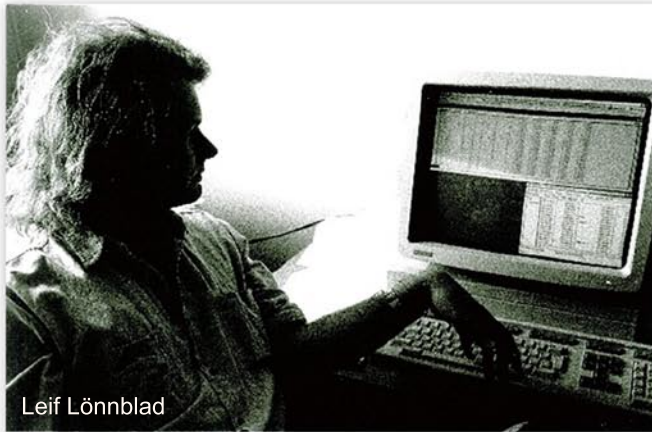

Leif Lönnblad

When quarks collide, gluons are produced. These gluons can in turn emit more gluons, forming a cascade. At very high energies, these cascades have an important effect on the results. Models of the cascades constitute important components in the description of high-energy collisions. A dipole formulation of such cascades was developed by Gösta Gustafson and Ulf Pettersson.

The simulation program ARIADNE, developed mainly by Leif Lönnblad, has been especially successful in describing electron–positron collisions. The dipole formalism is now generally used for the description of quark–gluon cascades.



Nuclear collisions

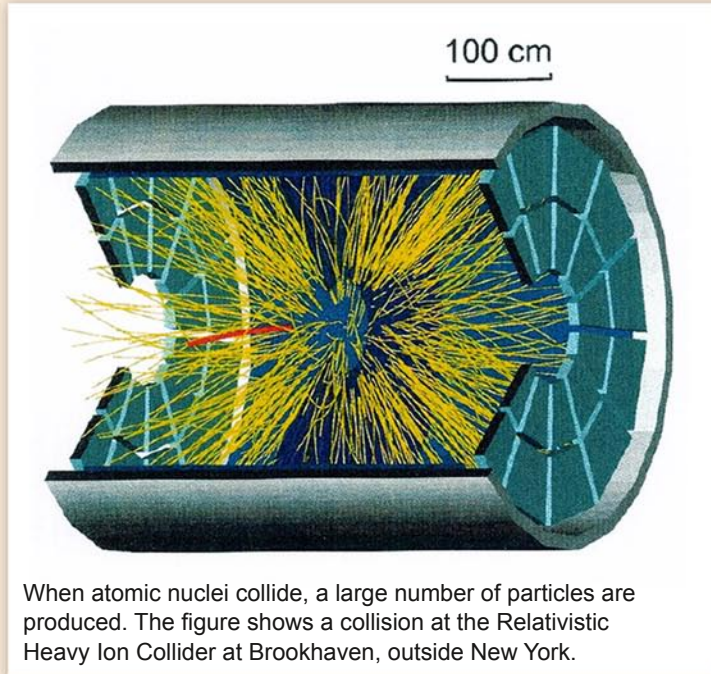

Working together with experimentalists has been very valuable. A collaboration between Bo Andersson and the experimentalist Ingvar Otterlund on nuclear collisions took place already in 1974, before the start of the Lund Model.

The collaboration resumed in the 1980s, leading to the development of the FRITIOF model, were the theoretician Bo Nilsson-Almqvist and the experimentalist Evert Stenlund together wrote the simulation program.

Studies on nuclear collisions have recently been resumed in connection with the development of the DIPSY model.



High gluon density

At high collision energies, the density of low-energy gluons can be very high. Beyond a certain value, the gluons can no longer be regarded as individual particles, but interact coherently. These effects can be expected earlier in nuclear collisions, and are therefore important in the analysis of a possible phase transition to a quark–gluon plasma.

The effects of high gluon density have been included in the DIPSY model. This model is especially suited to the study of the effects of fluctuations and correlations, and finds applications in collisions between electrons, protons and nuclei.

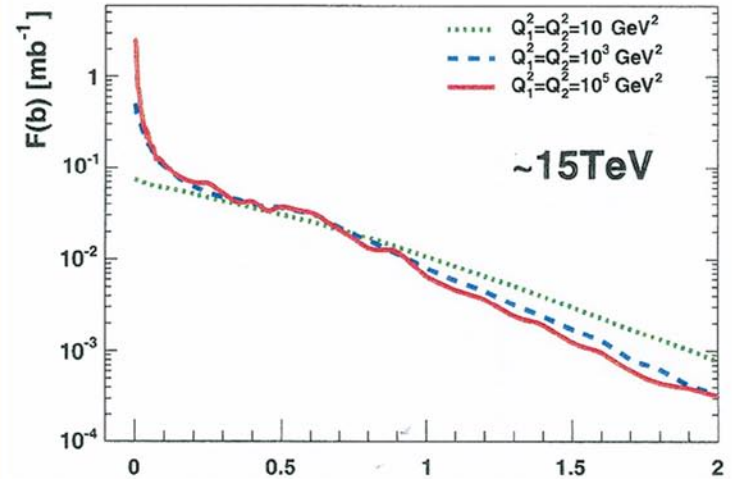

Correlation between two gluons in a proton at high energy, where b denotes the distance between the gluons in the transverse direction. The peak at $b=0$ indicates that many gluons are found close together. This is important for the possibility for two gluons to scatter simultaneously in a proton–proton collision.



Physics beyond the standard model

Efforts are now being concentrated on analysing the results obtained at the Large Hadron Collider (LHC) at CERN, where the presence of the Higgs particle was confirmed in 2012.

The Higgs particle constitutes the last component in the standard model of the microcosmos. A Higgs particle is produced in only one in 10 billion collisions, and it is therefore important to have good descriptions of both normal events and the expected Higgs signal. The PYTHIA Monte Carlo model had an important role in this context.

Work is now continuing with more detailed studies of the Higgs particle, and the search for signals that can be associated with the so-called dark matter in the universe.

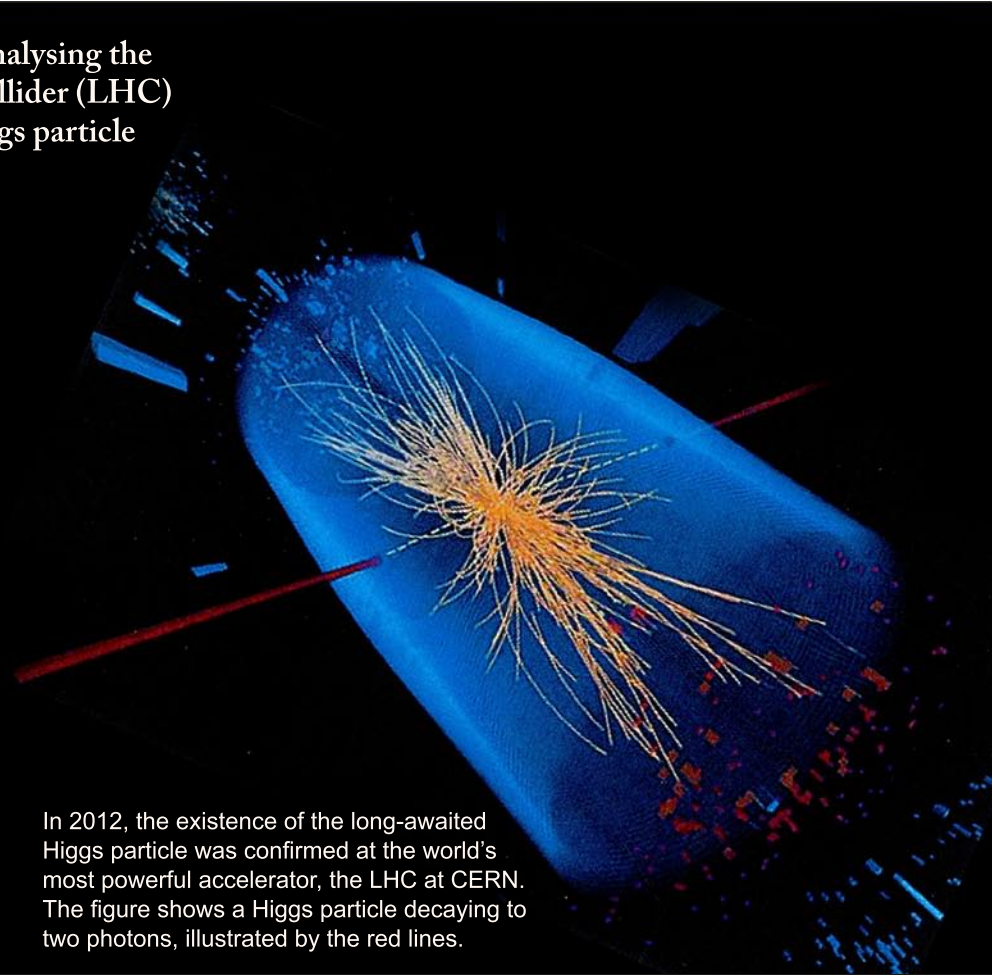

In 2012, the existence of the long-awaited Higgs particle was confirmed at the world's most powerful accelerator, the LHC at CERN. The figure shows a Higgs particle decaying to two photons, illustrated by the red lines.



Teaching and collaboration

Over 30 PhD students have got their training working on the Lund Model. Among these, Torbjörn Sjöstrand and Leif Lönnblad are now professors still working at Lund University. Gunnar Ingelman has established an affiliate in Uppsala, and some are now working in the theoretical biophysics group started by Carsten Peterson in Lund.

Contact with the experimental high-energy physics group at Lund has been extremely fruitful, leading, amongst other things, to the development of the FRITIOF model. During recent years, the two groups have together supervised seven EU-financed PhD students.



Hans-Uno Bengtsson (1953-2007), Bo Andersson and Gösta Gustafson. After obtaining his doctorate, Hans-Uno Bengtsson spent some time as a post-doc at UCLA. He was an accomplished and popular lecturer and speaker, and was director of studies at the department. He also wrote and translated a number of books.

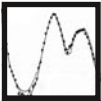

Important milestones

- A model for quark jet fragmentation (1977)
- A model for electron–hadron and hadron–hadron collisions, called the fragmentation model (1977)
- The first Monte Carlo program (1978)
- The Lund string fragmentation model (1979)
- Model for proton collisions based on multiple quark–gluon collisions. The beginning of PYTHIA(1986)
- FRITIOF, a model for collisions between hadrons and/or nuclei (1986)
- Dipole formulation of gluon cascades, ARIADNE (1988)
- PYTHIA is developed into a standard program that also includes hypothetical reactions, like the Higgs and supersymmetric particles (gradual development over many years)
- Saturation and small x , DIPSY (2005)

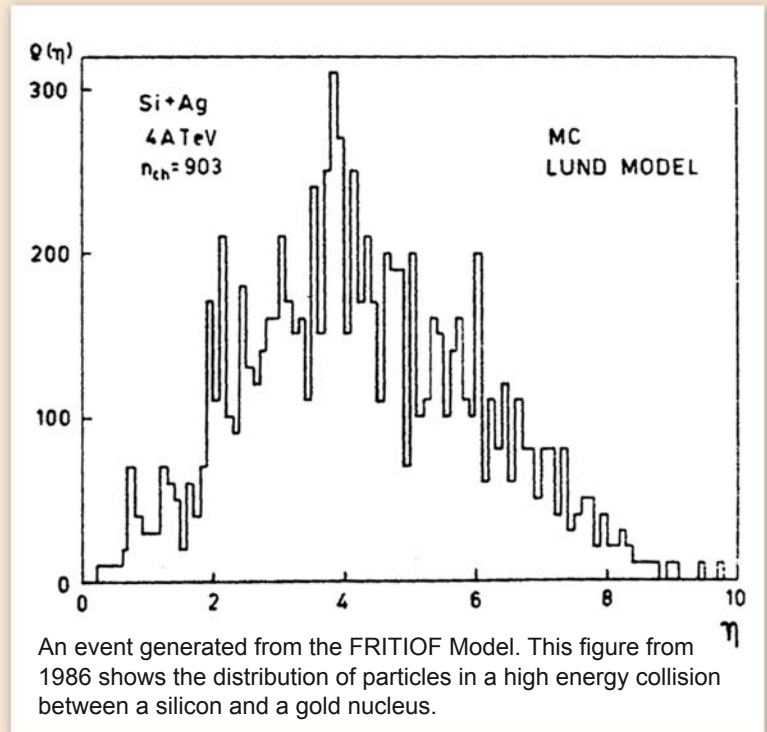

An event generated from the FRITIOF Model. This figure from 1986 shows the distribution of particles in a high energy collision between a silicon and a gold nucleus.



Carsten Peterson

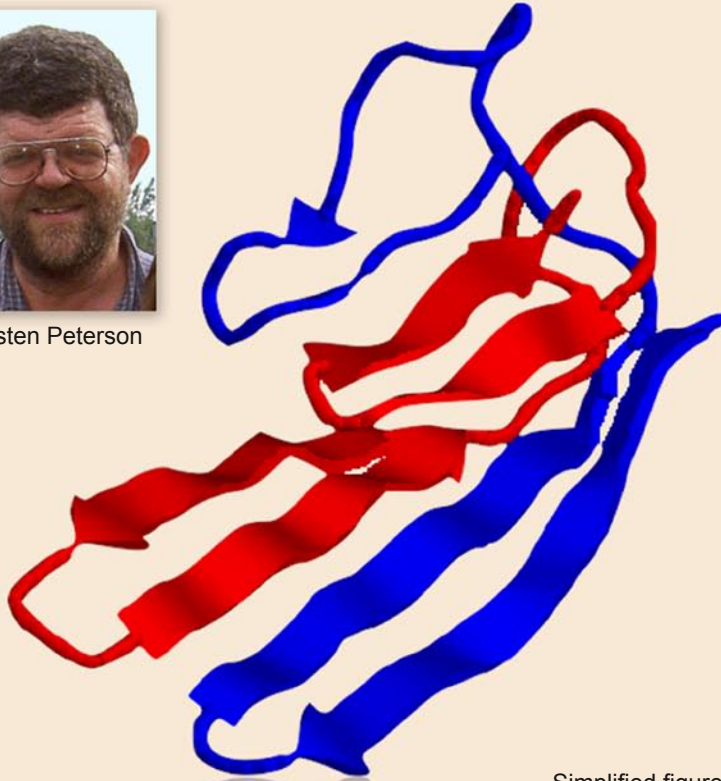

Simplified figure showing the results of modelling of the aggregation of A β peptides. This peptide consists of about 600 atoms, and is associated with Alzheimer's disease.

Carsten Peterson started his career with what was later to be the Lund Model, but he changed the direction of his work and started to study lattice QCD, where the usual continuous space-time is approximated by a discrete lattice, using statistical mechanical methods.

This approximation later served as the foundation for another step forward in 1988, which led to a number of new multidisciplinary subjects: Pattern recognition, complicated optimization problems, protein folding and the identification of biomarkers in cancer diagnosis.

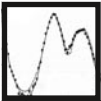

Stem cells differentiate

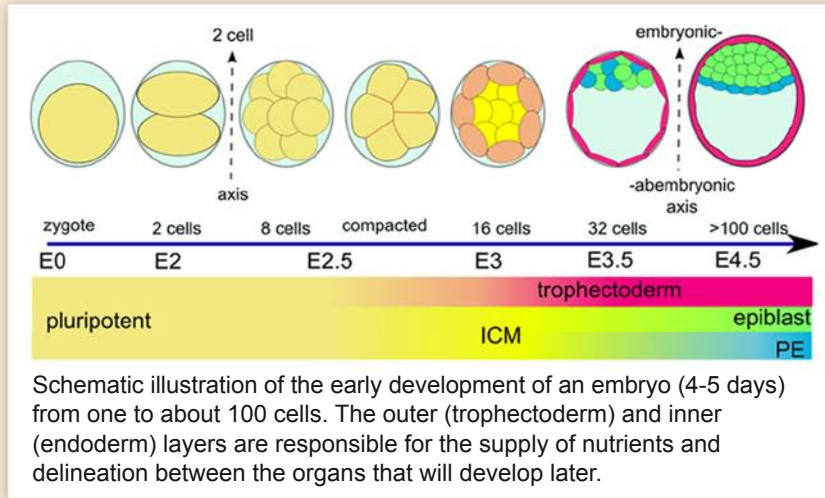

Considerable effort is currently being devoted to the modelling of the dynamics of genes and stem cells in an attempt to direct the development of the stem cells.

Studies are being carried out on how millions of blood cells can be produced each day from relatively few blood stem cells in the bone marrow, and the first stages of embryonic development.

Anders Irbäck and Mattias Ohlsson have developed their own areas of specialization in protein dynamics and clinical issues.

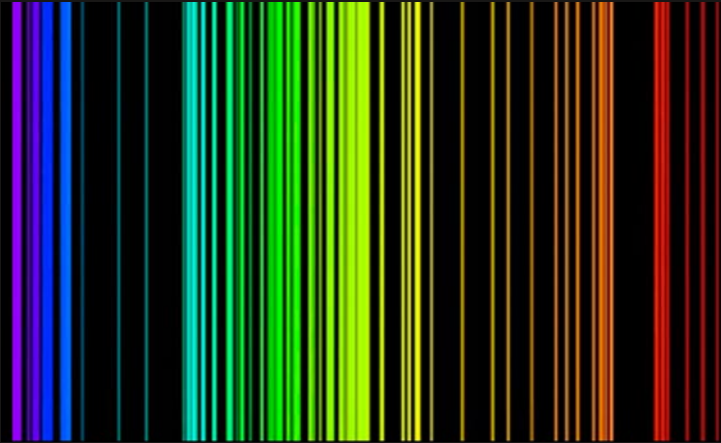

Fast atoms and shining stars

How spectral lines tell us the lifetimes of excited atoms and the chemical composition of stars.

Atomic spectroscopy – a tradition in Lund

The Department of Physics in Lund has a long tradition of the investigation of atomic spectra. The work performed by Rydberg and Siegbahn laid the foundation for our knowledge on the structure of atoms.

Siegbahn's successor, Koch, studied the effects of electric fields on atomic spectra, and Edlén's analysis of spectra from complex atoms and highly charged ions provided new knowledge on atomic structure.

When the Institute of Technology was founded in Lund, Minnhagen established a research division in atomic spectroscopy.



An X-ray spectrum on a photographic plate, recorded by Siegbahn.

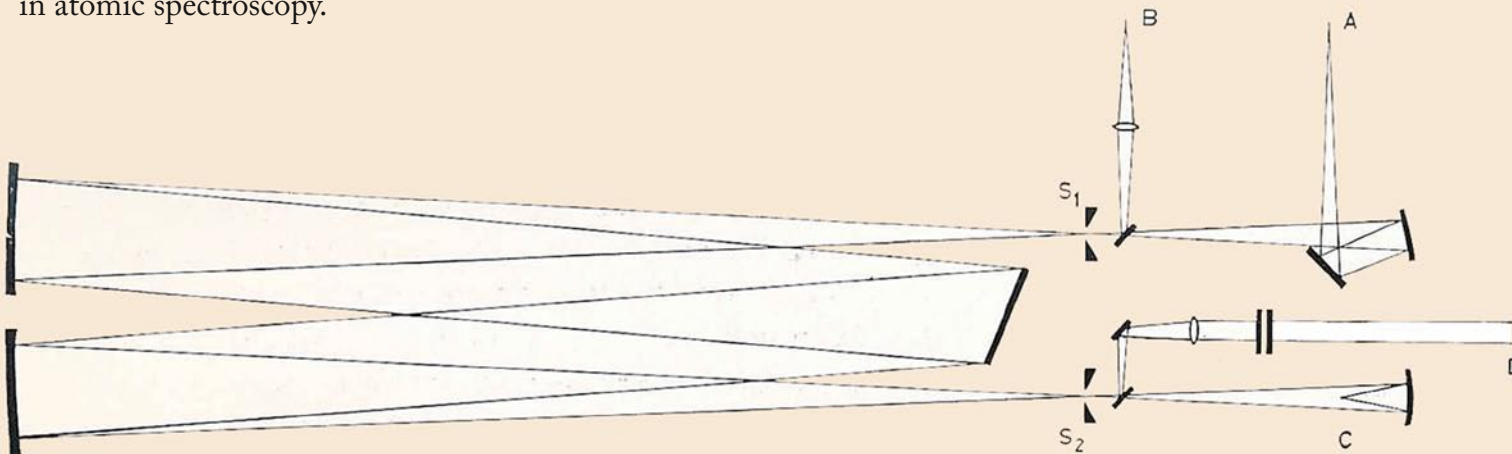

A spectrometer for infrared radiation, constructed in Lund in 1969.

Atomic lifetimes

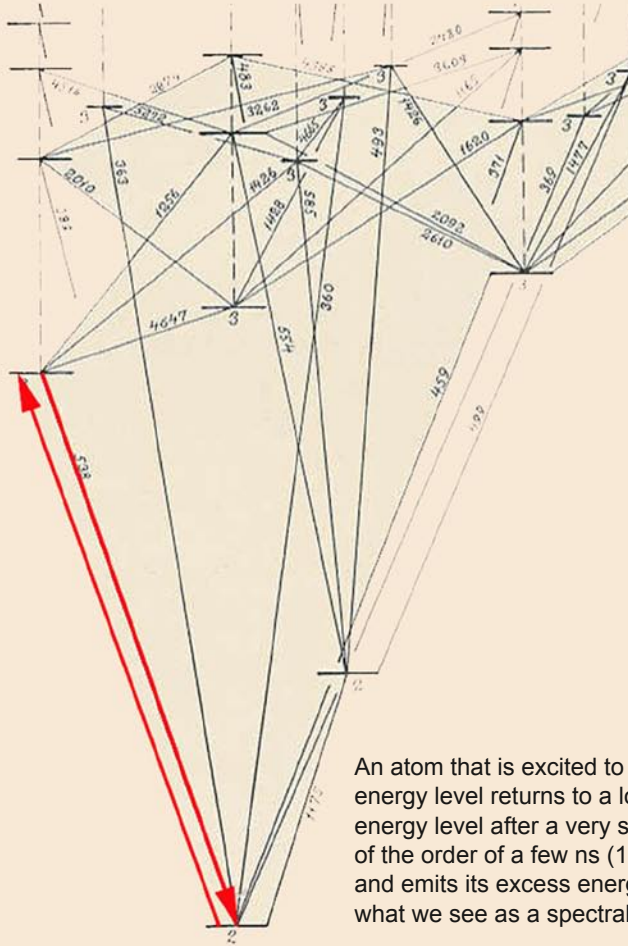

An atom that is excited to a higher energy level returns to a lower energy level after a very short time, of the order of a few ns (10^{-9} s), and emits its excess energy. This is what we see as a spectral line.



Indrek Martinson 1937-2009

Indrek Martinson took over from Bengt Edlén in 1975. He expanded the field of spectroscopy by introducing measurements of atomic lifetimes. Martinson had obtained his PhD in nuclear physics in Stockholm, under the supervision of Manne Siegbahn. During a period as a post doc in Tucson, Arizona he had learnt a new experimental method called beam-foil spectroscopy.

Beam-foil spectroscopy

In the beam-foil method, ions are excited by passing them through a thin carbon foil. The intensity of the emitted spectral lines decreases along the path of the travelling ions. If the velocity of the ions is known, the lifetime of the excited state can be determined. Instead of measuring a very short time, this method involves the much simpler measurement of a distance of a few cm.

The experimental equipment for beam-foil spectroscopy was set up at the Physics Department's Pelletron accelerator, where ions could be accelerated to velocities of 10,000 km/s.



A beam of lithium ions passes through a thin carbon foil, allowing two atomic decays to be observed, one which is short-lived (5 ns), and can be seen as the blue light, and a longer-lived one (46 ns), seen as the longer-wavelength green light.

Lifetime measurements

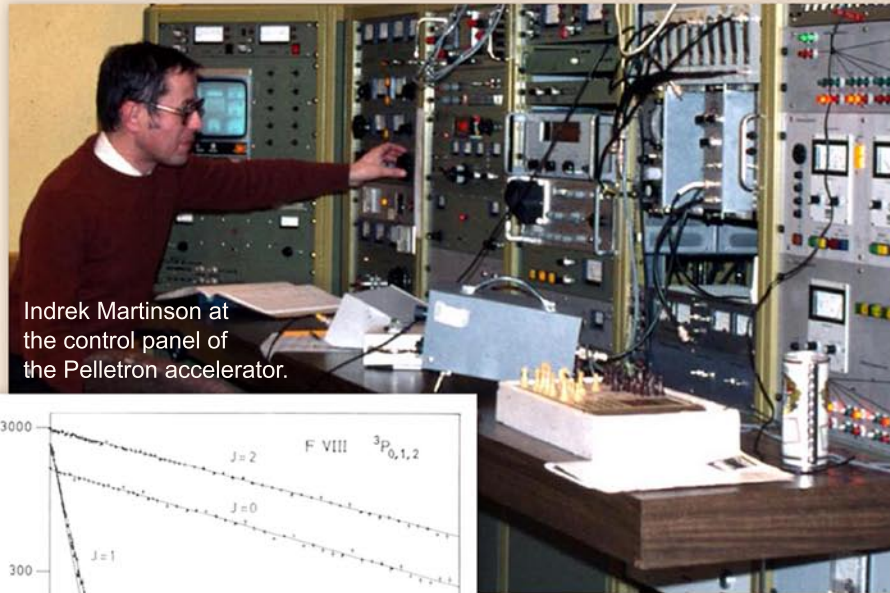

Indrek Martinson at the control panel of the Pelletron accelerator.

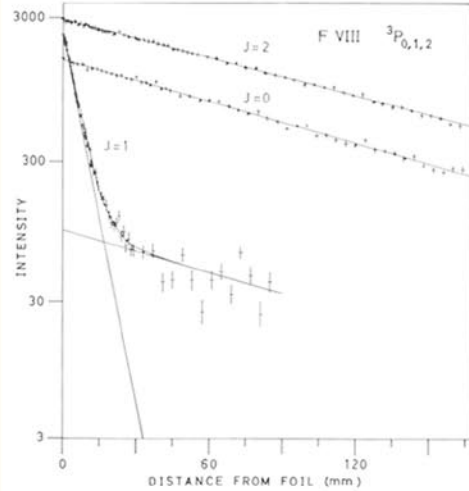

This figure shows the measurement of three states in a positively charged fluorine ion, F^{+7} . According to elementary theory, they should have the same lifetime, however, the experiment showed that one of the states ($J=1$) had a much shorter lifetime than the other two, which also differed a little. Extensive theoretical calculations showed that the difference in lifetimes was due to the spin of the electrons and the nucleus.

Measurements of atomic lifetimes at the Pelletron accelerator were combined with theoretical studies. The accurate lifetime measurements allowed various theoretical and mathematical models to be tested.

Highly charged ions

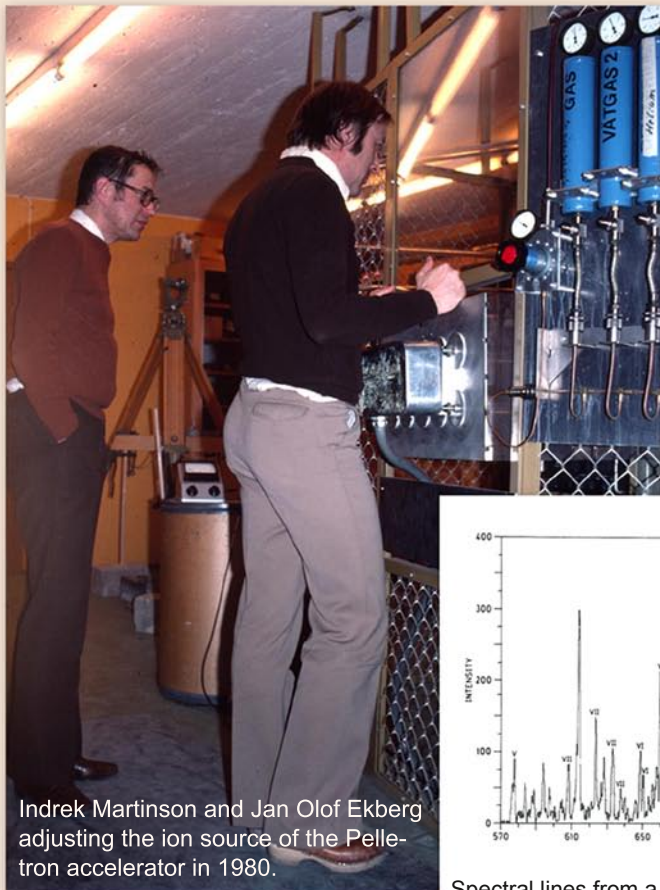

When positive ions pass through the carbon foil, one or more electrons are stripped off, increasing the positive charge on the ion. The beam-foil method can, therefore, also be used to analyse the structure of highly charged ions of, for example, fluorine and sulphur.

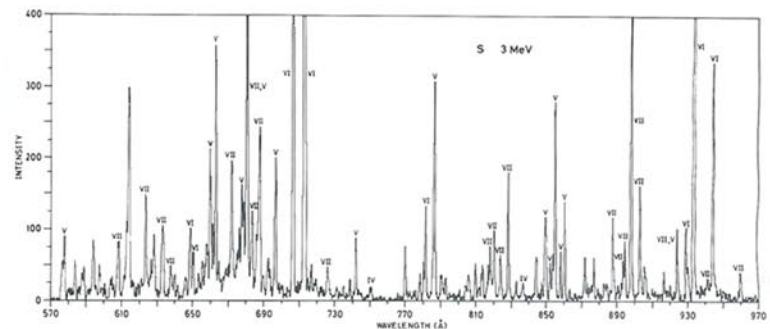

Spectral lines from a beam of positively charged sulphur ions: S^{3+} , S^{4+} , S^{5+} , S^{6+} .

Laser-generated plasma

The energy structure of highly charged ions can also be studied with high-energy lasers with pulse energies of 1 GW. The laser beam is focused onto the material to be studied using a lens. The energy of the pulse was so high that a plasma was formed at a temperature of a million degrees. The ions in the plasma lost up to 20 electrons.

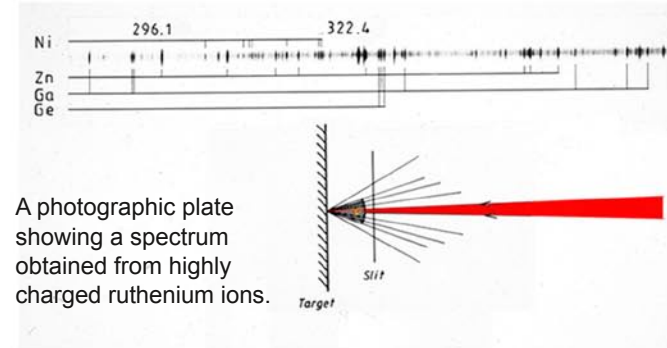

A photographic plate showing a spectrum obtained from highly charged ruthenium ions.



Ulf Litzén, one of Lund's atomic spectroscopists, beside the high-energy laser in 1985.

Plasma diagnostics

PhD students and postgraduates from the Division of Atomic Spectroscopy took part in international collaboration at laboratories in the UK (JET), and Princeton, USA. These experiments were aimed at producing energy by fusion resulting from the collision of deuterium and tritium atoms at temperatures of tens of millions of degrees.

The spectroscopists from Lund measured levels of contaminants by analysing spectra from the superheated plasma. These measurements are important, as even extremely small levels of heavier atoms reduce the temperature, preventing fusion from taking place.



Joint European Torus, JET.

Astrophysics in the lab

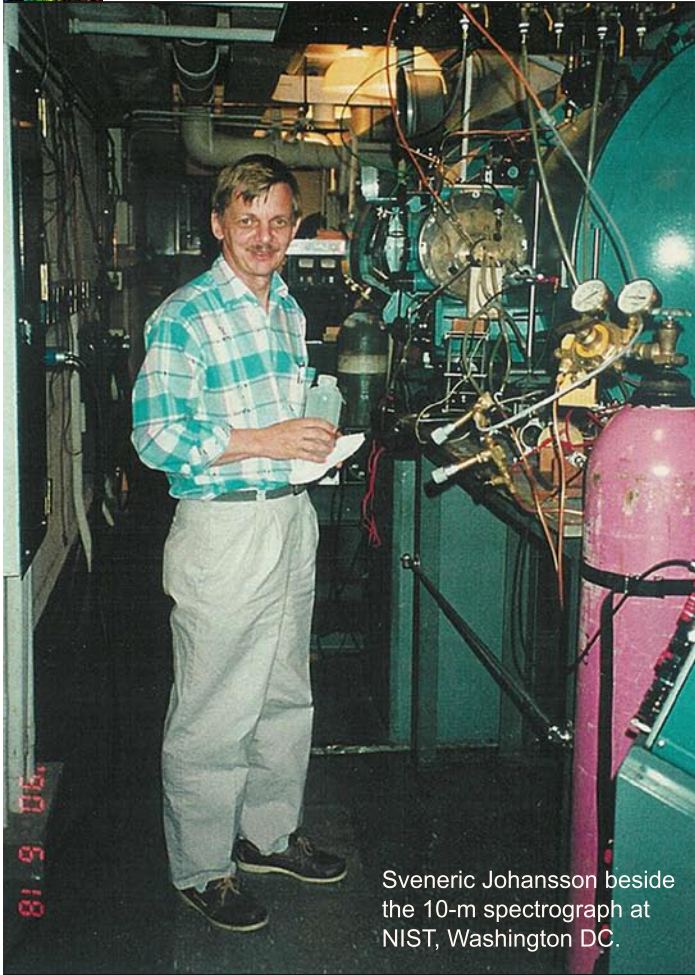

In 1970, Sveneric Johansson started his PhD studies under the supervision of Bengt Edlén. His research was on the structure of ionized iron, Fe^+ .

The spectra from several kinds of stars contain many spectral lines arising from iron. Sveneric's new measurements showed that there were many more lines from iron than previously thought.

After obtaining his PhD, Sveneric formed a research group to study astrophysics in the laboratory, and they investigated atoms of special interest in astronomy.

The Hubble Space Telescope

Sveneric Johansson spent a year as a visiting scientist and expert in atomic spectroscopy at the NASA Space Flight Center. When the Hubble Space Telescope was launched in 1990, the research group from Lund were given plenty of observation time.

As the telescope was in space, above the Earth's atmosphere, it was possible to see detailed spectra of stars in the ultraviolet wavelength region for the first time. The group in Lund was no longer only analysing spectra in the lab, but also stellar spectra from space.



The spectrum of a star provides information on the elements present. If sufficient knowledge is obtained from laboratory experiments, it is possible to determine the amounts of elements, and other characteristics of stars.

Analysis was carried out in Lund of, among other things, stars with very high amounts of heavy elements such as gold and platinum. It was found, for example, that the amount of gold and platinum in the star Chi Lupi was 30,000 times higher than in our planetary system. This unusual composition was thought to be due to processes leading to the enrichment of heavy elements in the outer layers of stars. The Lund group was also the first to find thallium in a star.

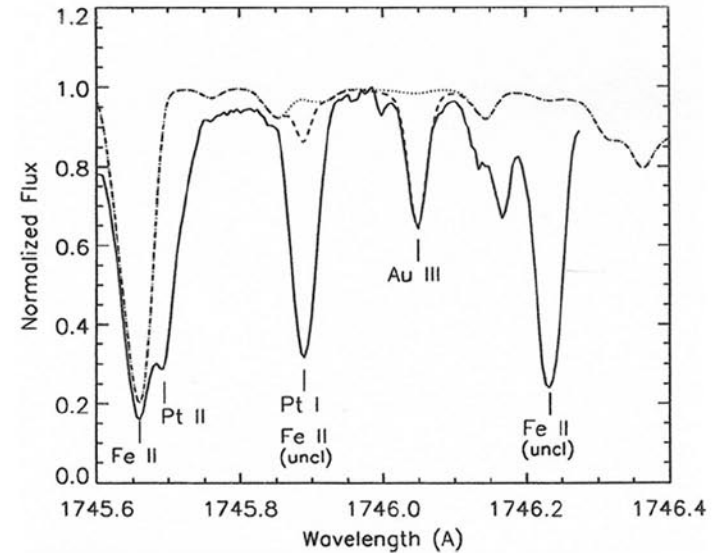

Details in the UV spectrum from Chi Lupi showing spectra lines from Au, Pt, and Fe.

Fourier transform spectroscopy

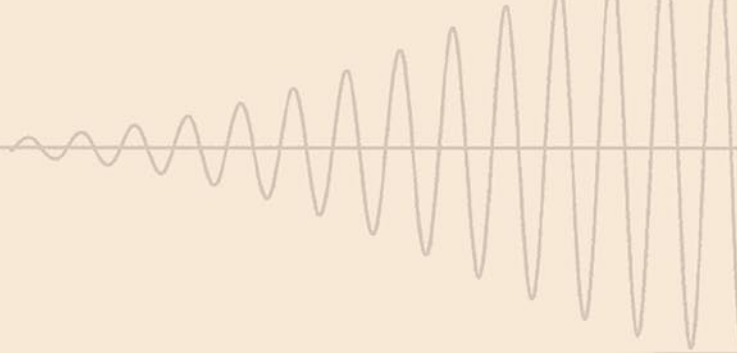

Accurate laboratory measurements of wavelength are required to identify spectral lines in a stellar spectrum containing many lines from different elements. It is also necessary to measure the intensity of lines in the laboratory in order to determine the amount of each element.

A new high-precision method for spectroscopic measurements is Fourier transform spectroscopy (FTS), which employs an interferometer with very high resolution. The interferogram recorded is a Fourier transform of the spectrum, which is then analysed in a computer.

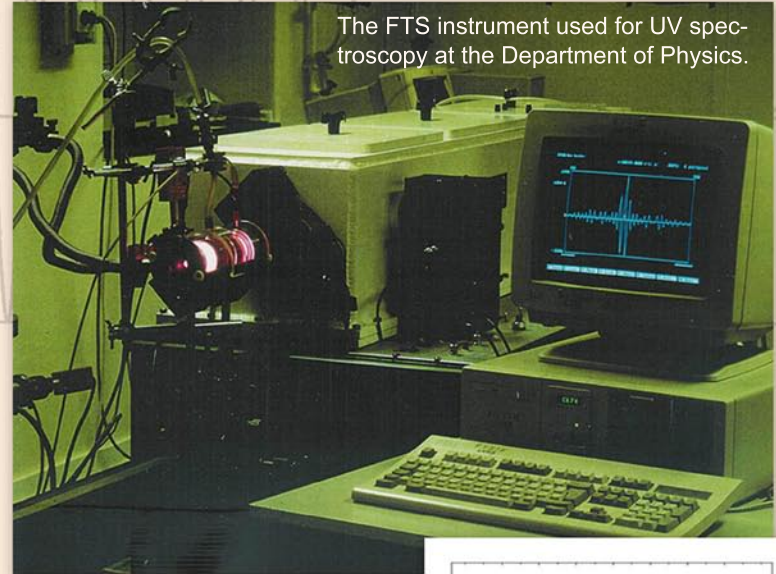

The FTS instrument used for UV spectroscopy at the Department of Physics.

FTS gives very high resolution, allowing the structure of spectral lines resulting from the spin of the atomic nucleus to be seen.

The figure shows the structure in three lines resulting from Pr^+ (the ion of the element praseodymium).

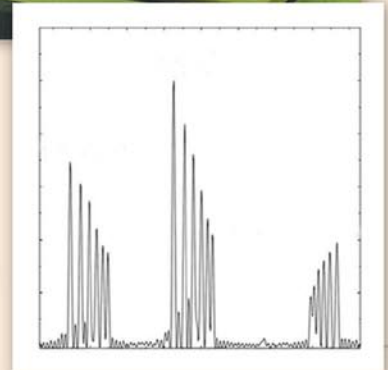

Intensity measurements

Henrik Hartman measuring absorption in a plasma of Fe ions at MAX-lab in Lund.

The parameters that determine the intensity of spectral lines are also measured at MAX-lab and the Laser Centre in Lund. Very long lifetimes, indicating forbidden transitions (with very low probability) of the kind observed in nebulae, were measured at the CRYRING storage ring in Stockholm.



Eta Carinae

Eta Carinae is one of the heaviest stars in the Milky Way. In 1837 an eruption was observed that was to last for several years, making it one of the brightest stars in the southern hemisphere. Enormous gas clouds were seen, forming two lobes. In the plane between the two lobes are a number of very bright gas bubbles. The line spectrum emitted by these bubbles was analysed in Lund. Observations were made with the Hubble Space Telescope.

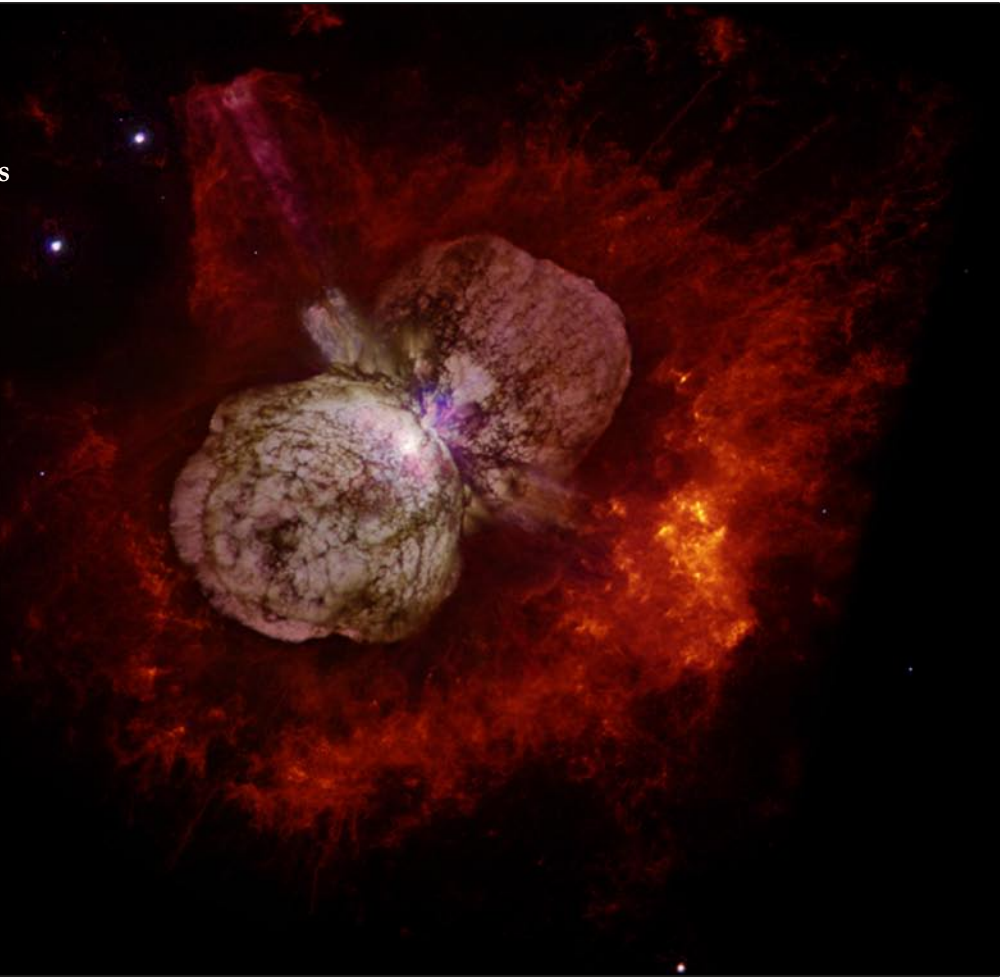

A laser star?

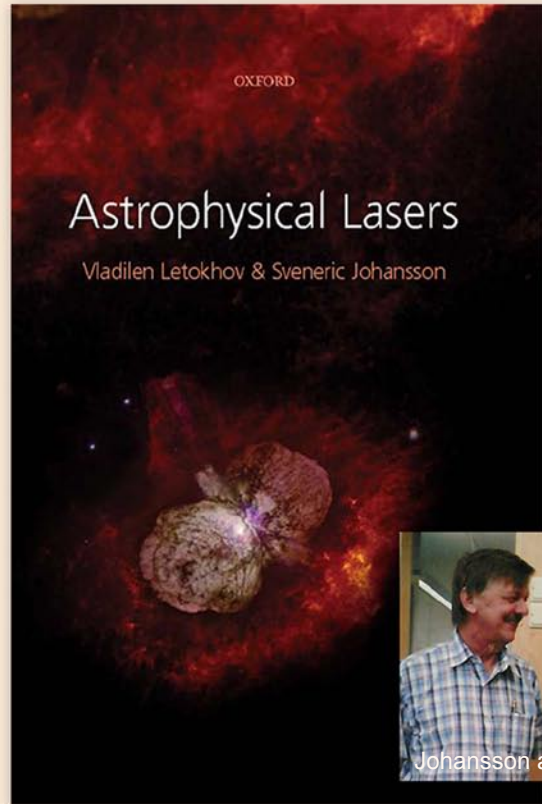

Johansson and Letokhov

Sveneric Johansson and Vladilen Letokhov described their research in the book, *Astrophysical Lasers*, which was published posthumously in 2010, just a year or two after the two physicists had died.

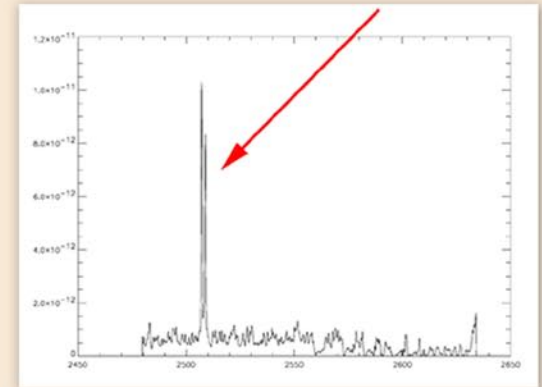

Sveneric Johansson identified a large number of Fe^+ lines in the gas bubbles around Eta Carinae, two of which were much stronger than the others. However, they were not especially prominent in laboratory measurements.

Sveneric and the Russian laser expert Vladilen Letokhov were able to show that the increased intensity of the two lines was due to stimulated emission, or lasing, in the bubbles.

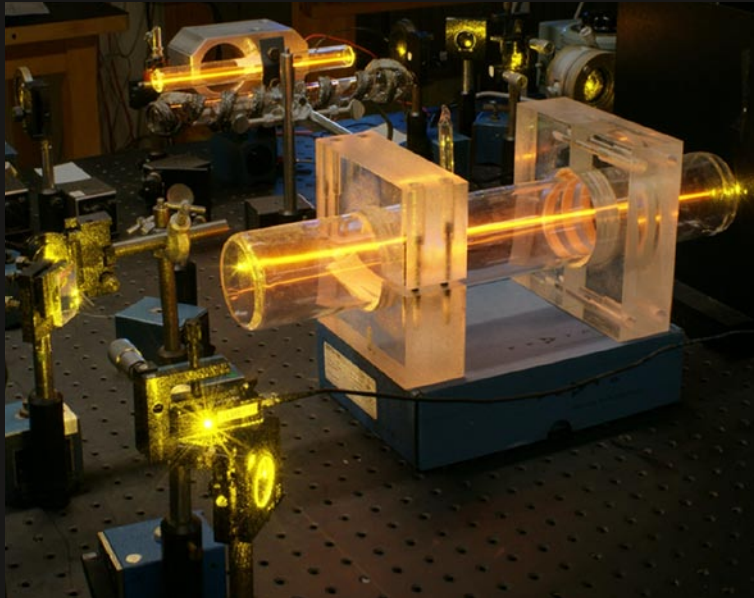

When the laser came to Lund

On how it happened and how it eventually led to a world record.

The world's first laser

In 1917 Albert Einstein realised that the new phenomenon of stimulated radiation emission should exist.

In 1954 the phenomenon could be demonstrated in an experiment for the first time and in 1960 American physicist Theodore Maiman constructed the world's first laser.

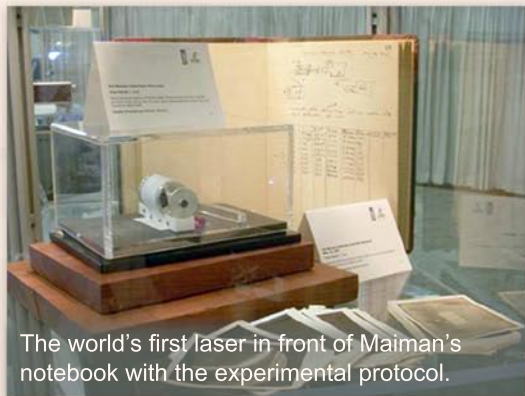
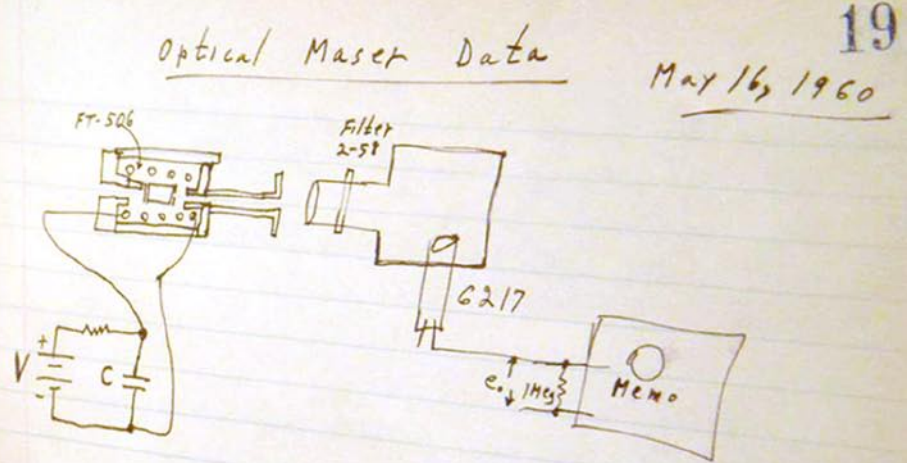

The world's first laser in front of Maiman's notebook with the experimental protocol.

Monochromator slits $\times (3.3A)$
 Photo multiplier 0.1 mm x 10 mm, set on center of R₁

V	C	$\frac{1}{2} CV^2$	E_0 peak	$\phi(\lambda)$ half width	Area of peak x width	initial slope	to 90% rise
800 v	875 μ fd.	280 w.s.	20 mv	5 msec	100		
950 v	875 μ fd.	395 w.s.	35 mv	4 msec	140		
1075	875	500 w.s.	61 mv.	2.8 msec	171		
1150	875	575 w.s.	85 mv.	2.1 msec	170		
1240	875	670 w.s.	155 mv				
1320	875						
1400	875						

What can a laser be used for?

The laser quickly became an effective aid for basic research and over time also turned out to have many different applications. Today lasers are used in many diverse fields, such as medical laser treatment, fusion research and entertainment.



What is a laser?

Unlike a normal light source, where the light shines out in all directions and with many colours, the light in a laser has been concentrated to a narrow beam with a specific colour.

The usual state in a material is a normal population, whereas in a laser there is an inverted population. The inverted population is achieved with the help of pumping, for example with a strong flash lamp, which means that instead of the light being muted it is intensified.

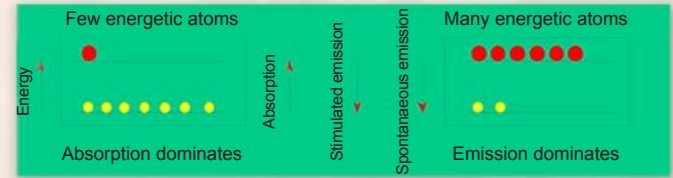

Various atomic systems.
Normal population. Inverted population.

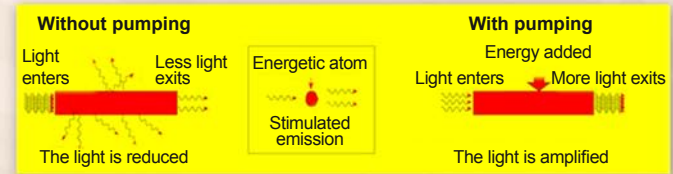

Amplified light.

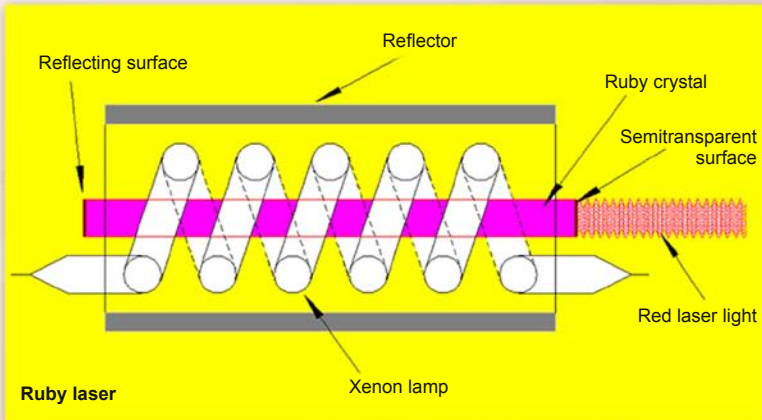

With the addition of mirrors, it is possible to create a light source, such as a ruby laser, with very special properties. The light from the laser becomes extremely intense and useful.

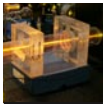
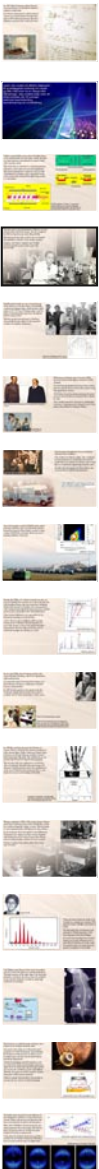

The first laser to be built in Lund

The laser came to the Department of Physics in Lund with the help of Kjell Bockasten. He had completed his PhD in Spectroscopy under Bengt Edlén.

Kjell had previously built a HeNe laser in Uppsala and published a number of key articles on lasers.

Together with Mario Gallardo and Osvalde Andrade, Kjell Bockasten built Lund's first laser in 1966.

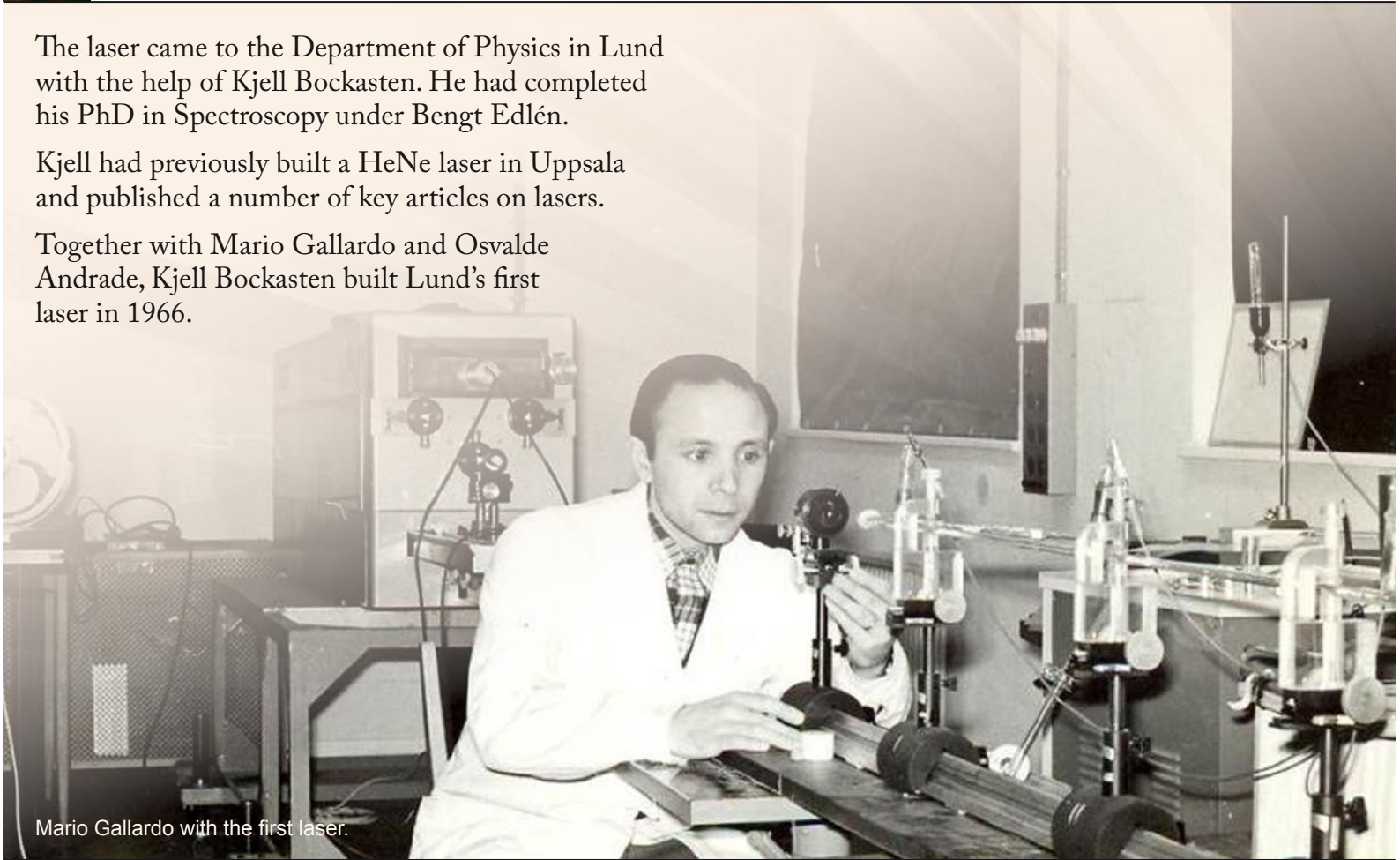

Mario Gallardo with the first laser.

The laser group

Kjell Bockasten built up a new research group at the Division of Atomic Physics that initially constructed nitrogen lasers, which produce short pulses in UV (337 nm). Nitrogen lasers could be used to study absorption spectra in the element barium among others.

The laser group's measurements of Rydberg series produced new values for the ionisation energies of a number of elements.

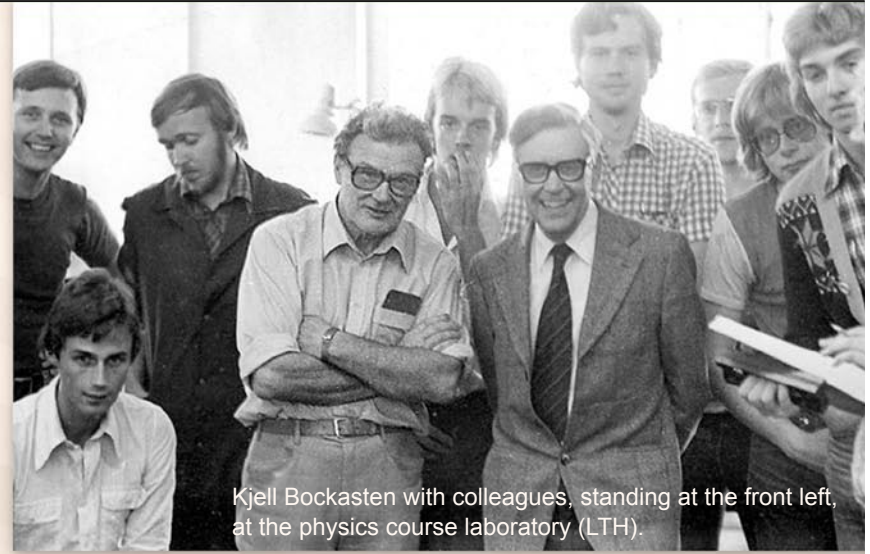

Kjell Bockasten with colleagues, standing at the front left, at the physics course laboratory (LTH).

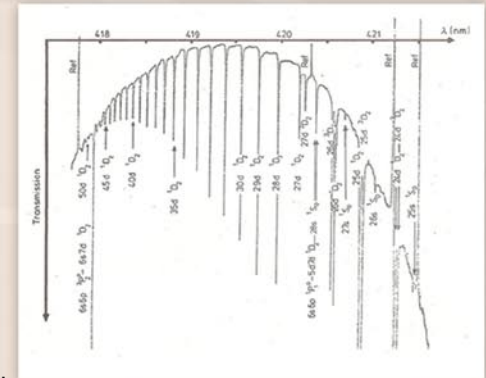

When Sune came to Lund



Sune Svanberg with new Nobel Prize Laureate Artur Schawlow in 1981.

When Sune Svanberg came to Lund in 1981 the focus of the atomic physics research at LTH changed.

From having principally been about classic atomic spectroscopy, the focus moved to laser spectroscopy and applications of lasers.

With Sune's broad knowledge and great inventiveness, the laser activities in Lund got off to a fantastic start.

New, modern laboratory exercises in combination with Sune's inspiring lectures attracted a lot of students to the Division of Atomic Physics.



Laboration om NdYag-lasern.

Four doctoral students and a bus



The stone table arrives for Marcus's laser system.

Sune Svanberg brought four doctoral students with him from Chalmers.

One of these was Marcus Aldén, who continued his measurements in combustion; this research would lead to an entirely new division and eventually to a combustion engineering research centre.

Another doctoral student was Hans Edner, who concentrated on LIDAR measurements.



The first LIDAR bus.

LIDAR (Light detection and ranging) is a technique used to measure an object's properties by illuminating it, for example with laser pulses.

Measuring air pollution

Sune had brought a mobile LIDAR system which had been built into a bus in Gothenburg and this formed the basis for Hans Edner's research. Later, a larger LIDAR bus was built, which was used to measure pollution at factories.

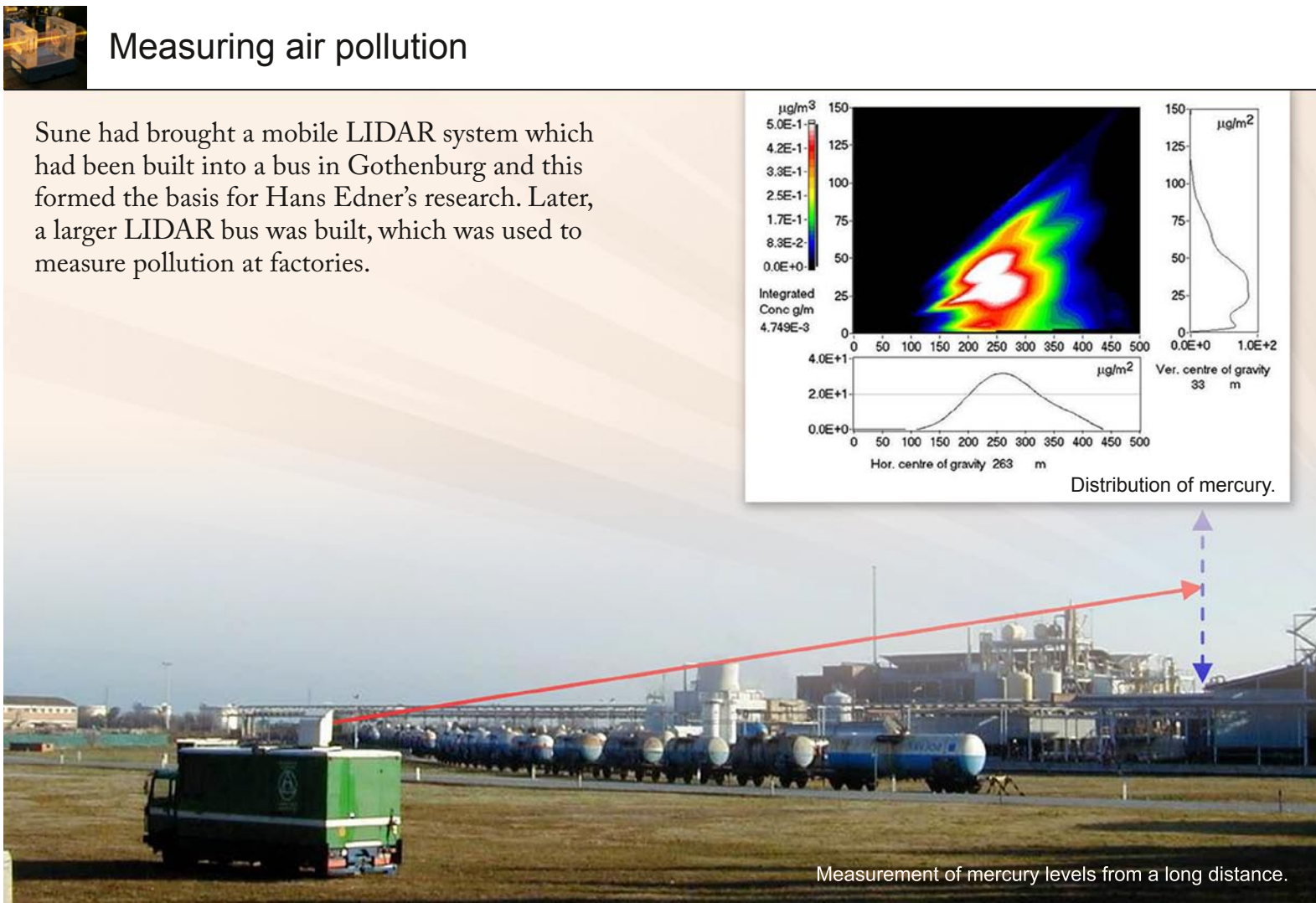
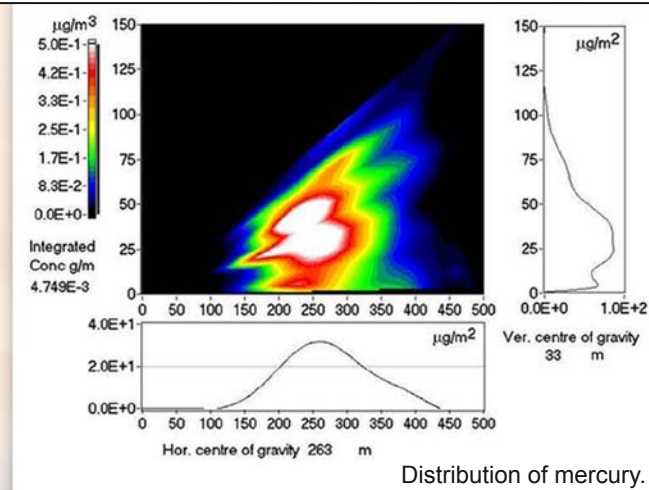

Measurement of mercury levels from a long distance.

Basic research

During the 1980s, a lot of basic research was also carried out. Initially, the research was on laser spectroscopy with broadband lasers, but later researchers including Stefan Kröll carried out Doppler-free measurements with continual narrowband dye lasers and time-resolved spectroscopy on hyperfine levels with pulsed lasers.

Claes-Göran Wahlström was responsible for the theoretical calculations at the division.

Anders Persson, who completed a PhD on laser measurement of lifetimes showed himself to be good with all types of lasers and gained an important position when the high-power laser was installed and brought into operation in 1992.

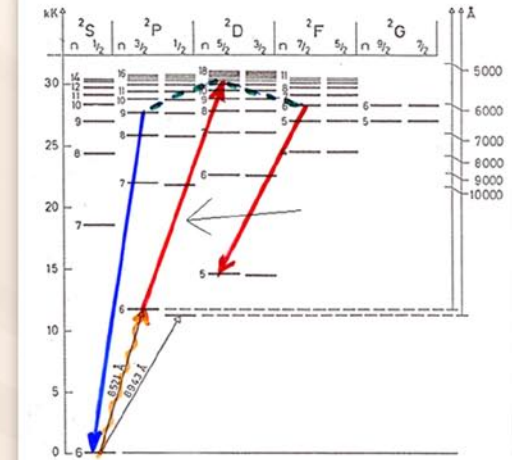

Laser spectroscopy in Cs I.

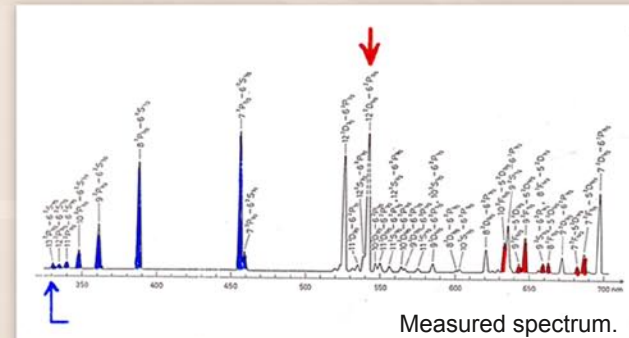

Measured spectrum.

Medical applications

In the early 1980s, Sune Svanberg and his wife, doctor Katarina Svanberg, carried out experiments with medical lasers.

An important method developed by Katarina was photodynamic therapy in combination with fluorescence measurements.

In 1987 the first patients were treated with photodynamic therapy and nowadays the method is routinely used to treat certain types of skin cancer.



Katarina Svanberg



Katarina Svanberg treating a patient.

When ALA (aminolevulinic acid) is injected into tissue, a tumour can be detected as it fluoresces in the light of a laser. Laser light of another wavelength can then be used to burn away the tumour.

Medical applications

In 1990 the medicine group at the Division of Atomic Physics, which by then had been reinforced with, among others, Stefan Andersson-Engels, Jonas Johansson, and Roger Berg, successfully scanned a hand using snake-like light. This method was an important step forward for optical mammography.

The successes with laser applications in medicine, such as treatment with photodynamic therapy and diagnosis with fluorescence, led to the establishment of the Lund Medical Laser Centre in 1991 to coordinate the research and teaching in the field.

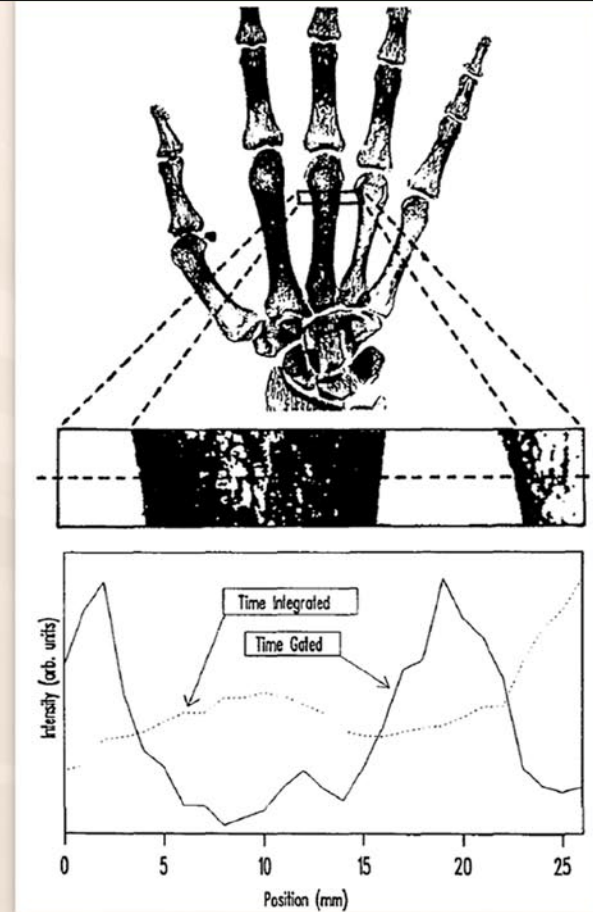

Scanning of a hand with snake-like light. The method produced much better contrast than normal measurement over time.

A high-risk project ...

Having completed a PhD in Theoretical Atomic Physics under Sune Svanberg, Claes-Göran Wahlström worked for a while at Imperial College London. There he learnt to work experimentally with high power laser physics.

In the meantime Sune had applied to the Wallenberg Foundation for a high power laser system. Together with Anders Persson he visited various laser laboratories to study possible solutions for such a system.

Despite warnings from experts, they chose a new type of system.

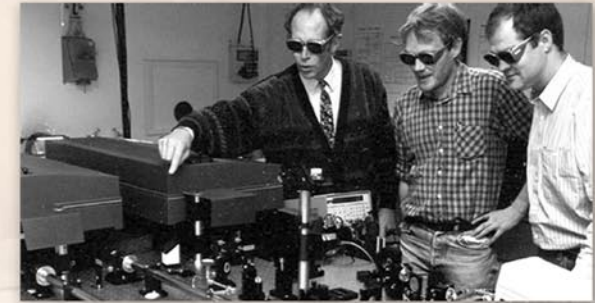

Sune Svanberg, Anders Persson, and Claes-Göran Wahlström with the TW laser system.

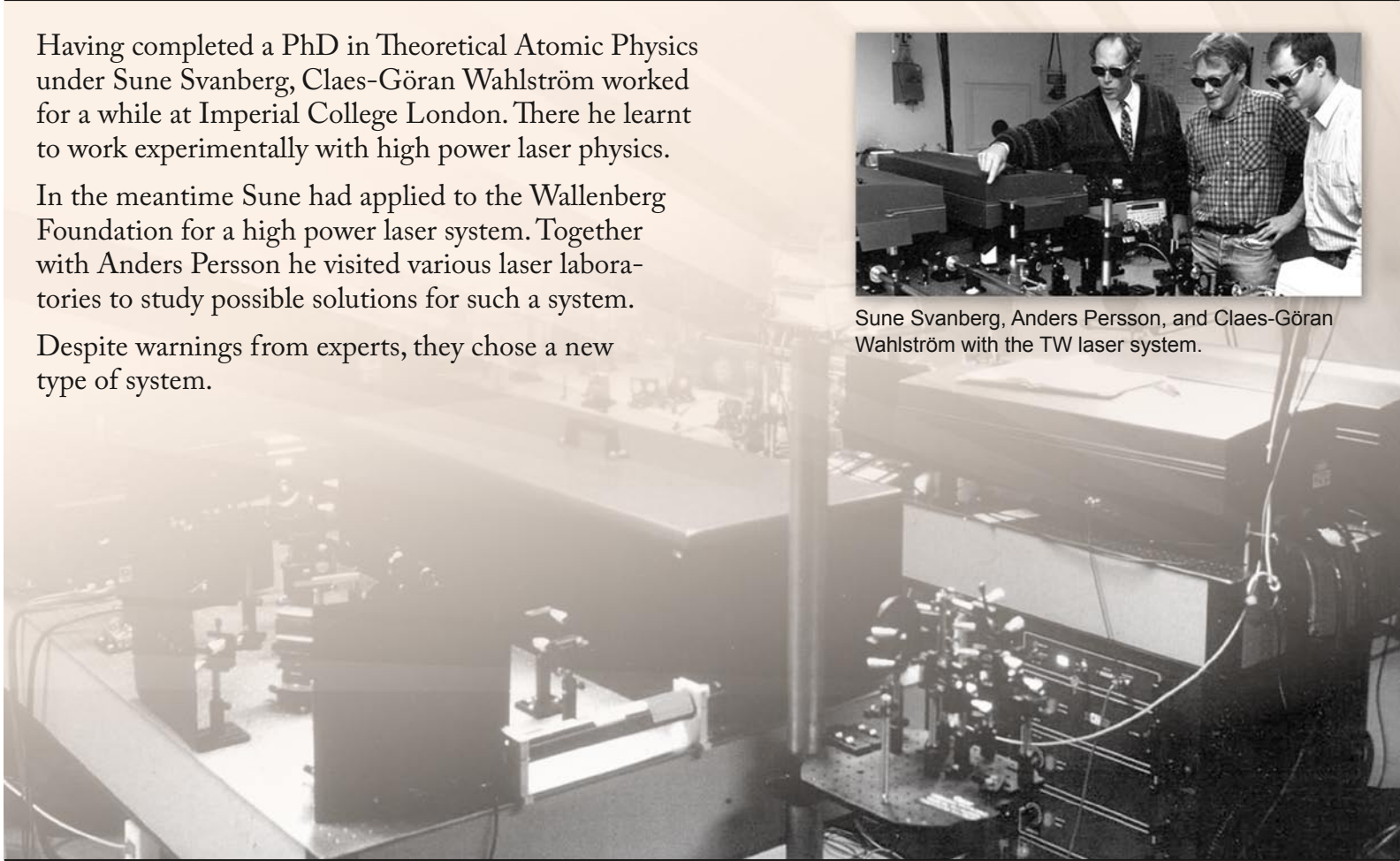
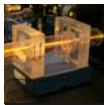

... that became a success!



Anne L'Huillier

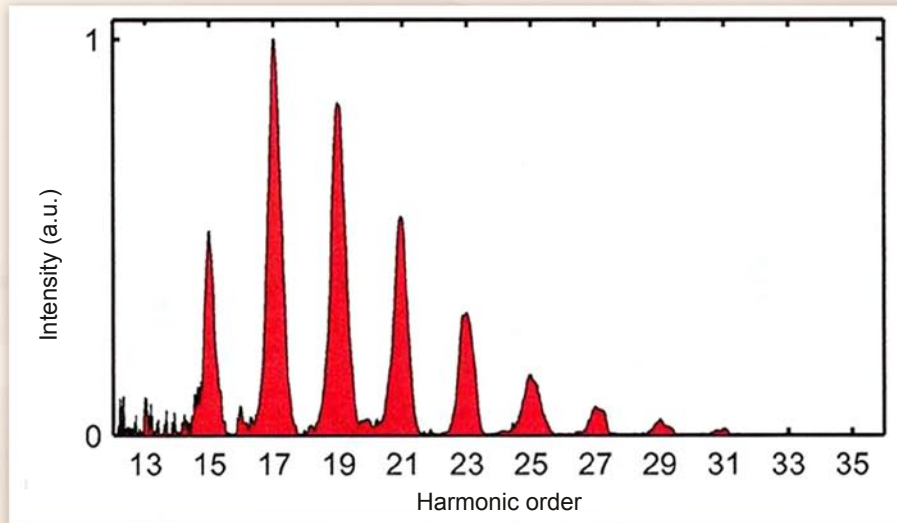

When the laser system was ready to be brought into operation in autumn 1992, physicist Anne L'Huillier was invited to Lund.

She had started the development and generation of high harmonics of the laser frequency at home in France.

In Lund Anne developed her research further and quickly obtained good results. The fact that the new laser could be operated with a very high pulse frequency contributed to her results.

Creating X-rays

Carl Tillman used the new laser source in another way. He focused the light on a rotating metal plate. The high intensity of the light when it hit the metal produced a strong X-ray source. Since the radiation source was very small, he was able to create high resolution X-ray images.

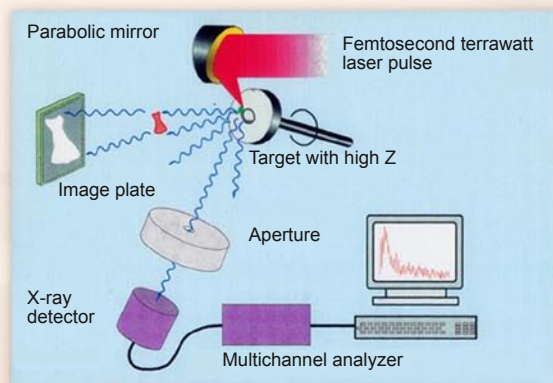

X-ray image of a rat.

Diode laser spectroscopy

Diode lasers are small and cheap and their wavelength can be changed relatively easily.

One person who made use of the diode laser's properties was Peter Kaurannen. By modulating the frequency of the laser he was able to use it to analyse gases and also demonstrated this in laboratory experiments.

Gabriel Somesfalean and Ulf Gustafsson took the diode laser further and developed many new applications for diode laser spectroscopy. Gabriel also started the GASMAS project with Mikael Sjöholm; the project involved a method of measuring gases within porous materials.

Märta Lewander showed that it was possible to measure the gas content of sealed packaging.

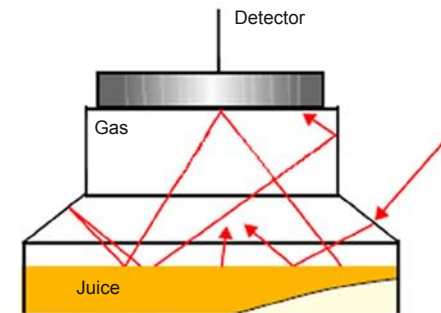
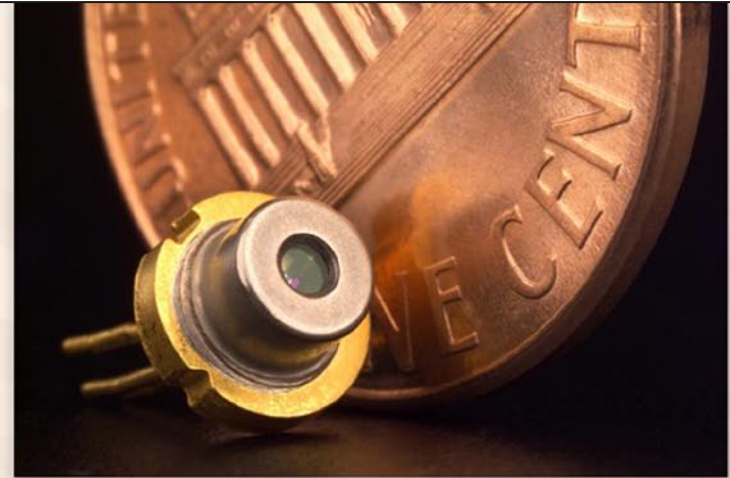

Measurements of gas inside a package of juice.

World record for short laser pulses

Nowadays, lasers are used in most divisions of the Department of Physics. At the Division of Atomic Physics, the picosecond laboratory has been converted into an attosecond laboratory.

Here, Anne L'Huillier's research group has generated extremely short laser pulses that last less than 170 attoseconds (as). In 2003 the pulse length 170 as was a world record!

Using these short pulses, it has been possible to measure the movement of electrons when they leave an atom and bob away on a light wave!

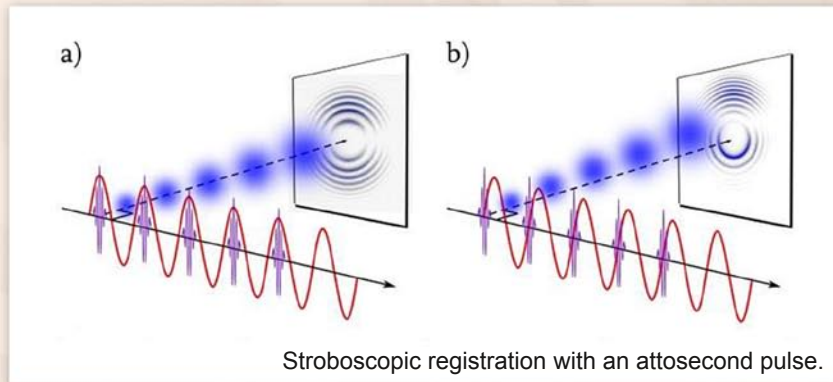

Electrons leaving the nucleus of the atom.

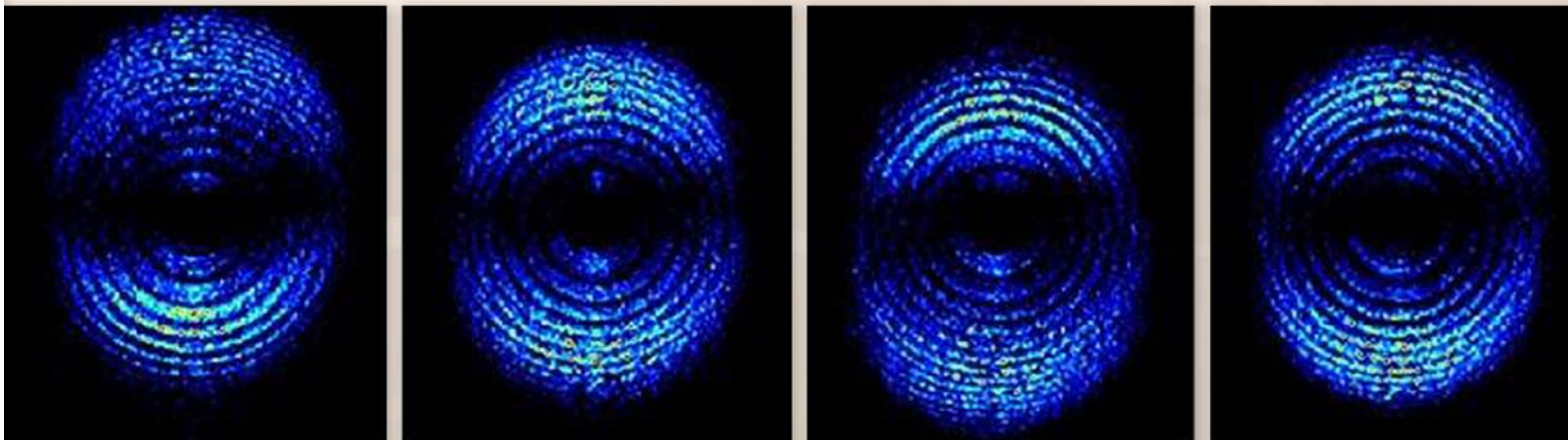

MAX-LAB

nationellt elektron och
synkrotronljus laboratorium

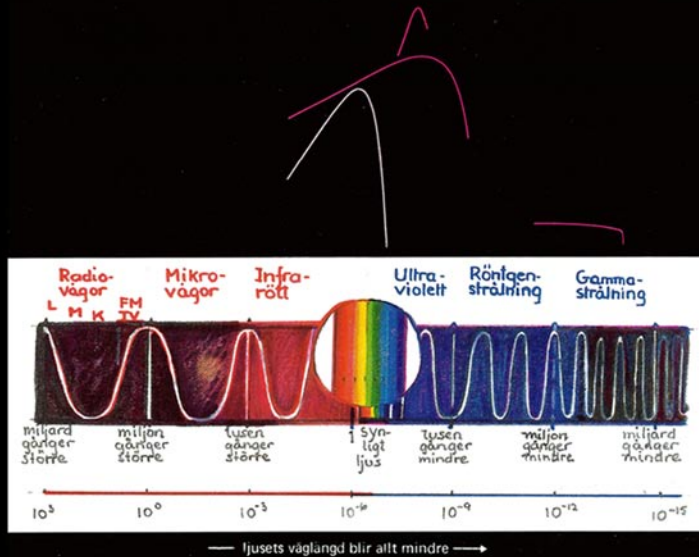

"Lord of the Rings"

The story of baby MAX
– how he learned to walk
and grew up to be big and strong.

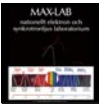

A small ring

Sweden's first electron accelerator was built in Stockholm at the Royal Institute of Technology, KTH, in 1945. It had a diameter of 13 cm, and was able to accelerate electrons in circular path, to an energy of 2 MeV.

Its designer, Olle Wernholm, built increasingly larger accelerators, and in 1953, the Department of Physics in Lund took over his latest creation, a 35 MeV electron synchrotron.

Kurt Lidén, assistant professor, later to become a professor in radiation physics, and Sten von Friesen, professor in nuclear physics, were responsible for the accelerator being located in Lund.

1 MeV is the energy of an electron when it is accelerated by a potential of 1 million volts.

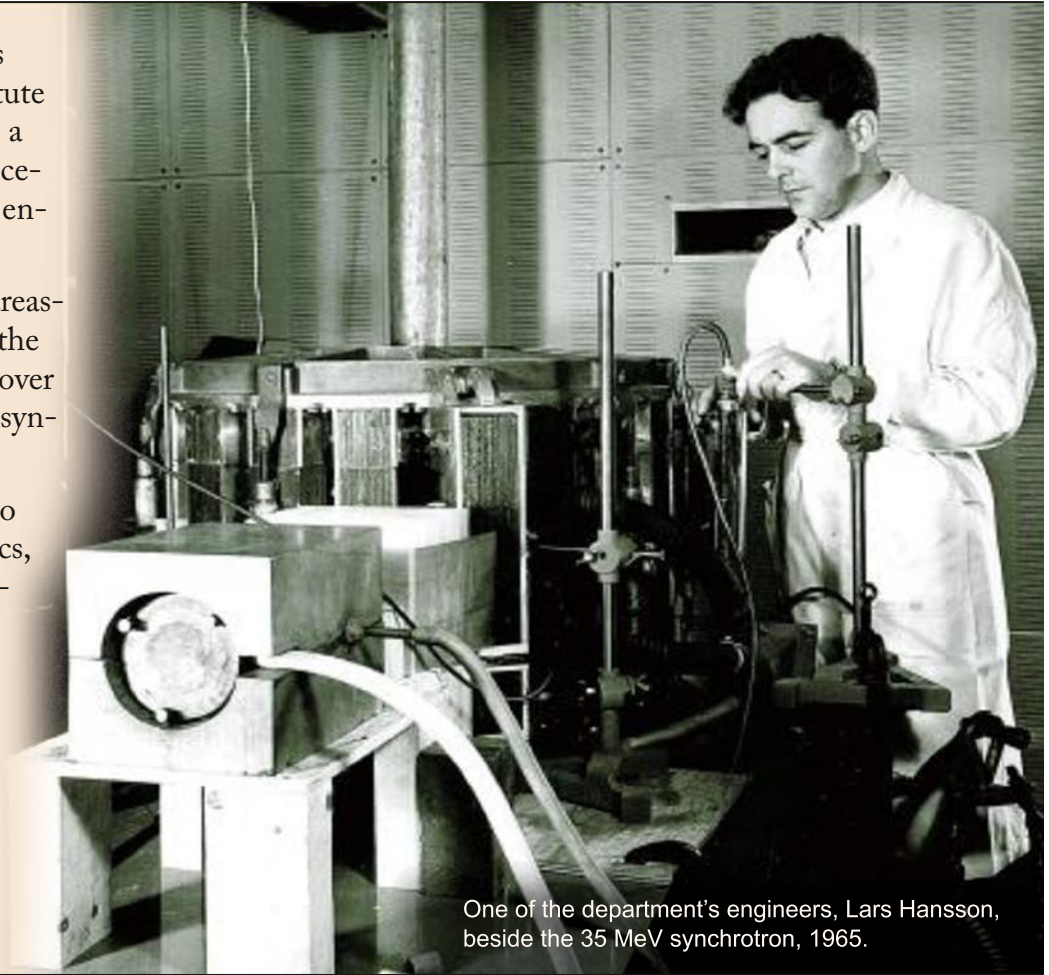

One of the department's engineers, Lars Hansson, beside the 35 MeV synchrotron, 1965.

A larger ring

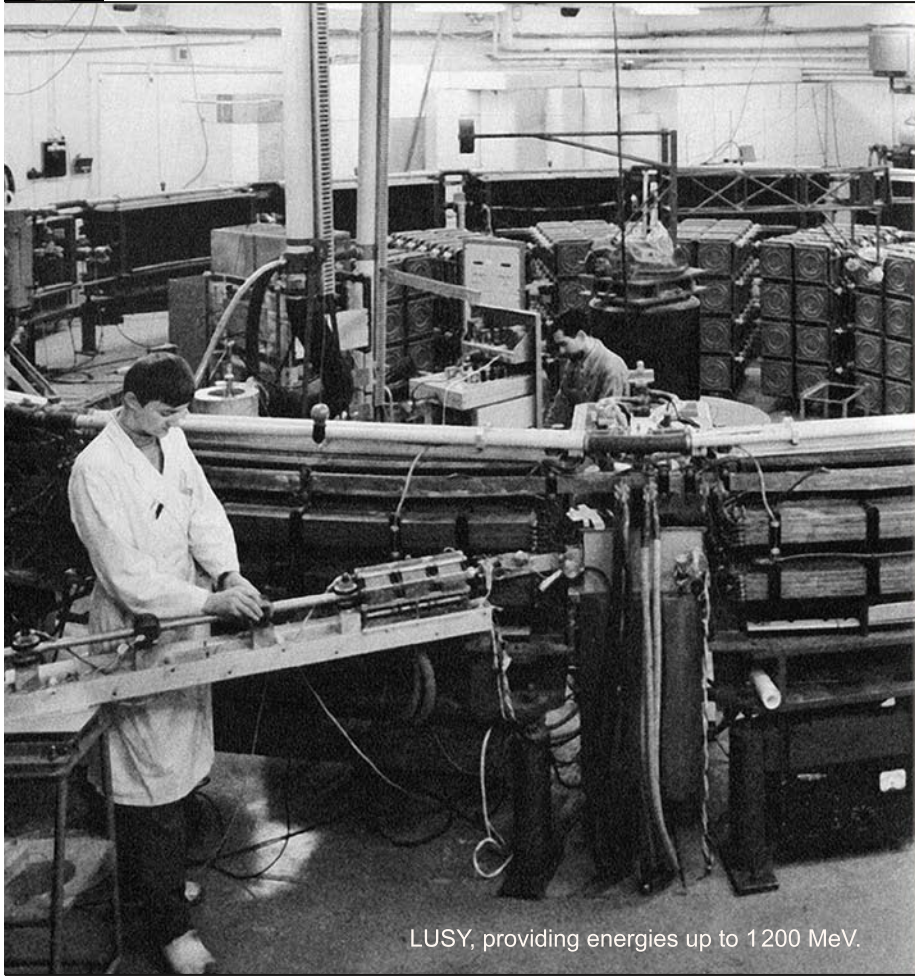

LUSY, providing energies up to 1200 MeV.

The 35 MeV synchrotron was used for experimental nuclear physics. After a while, there was a need for higher energies to study mesons and other newly discovered particles.

Olle Wernholm had plans for a larger synchrotron. The question was whether it would be located in Lund or Uppsala. Thanks to Sten von Friesen, a number of companies in the region provided funding for a building in Lund to house the accelerator – where it was placed. The accelerator was called LUSY – the Lund University Synchrotron.

The principle of the synchrotron

Electrons are accelerated by an electric field, and are then injected into a circular accelerator. Their energy is increased with every revolution in the system by regions with a high-frequency electric field, which are synchronized with the period of revolution, hence the name synchrotron.

The radius of the electrons' path is determined by their velocity and the strength of the magnetic field bending them into a circular path. If the velocity of the electrons entering the ring is close to the speed of light, the extra energy they gain increases their mass instead of their velocity, and the electrons remain in the circular path.

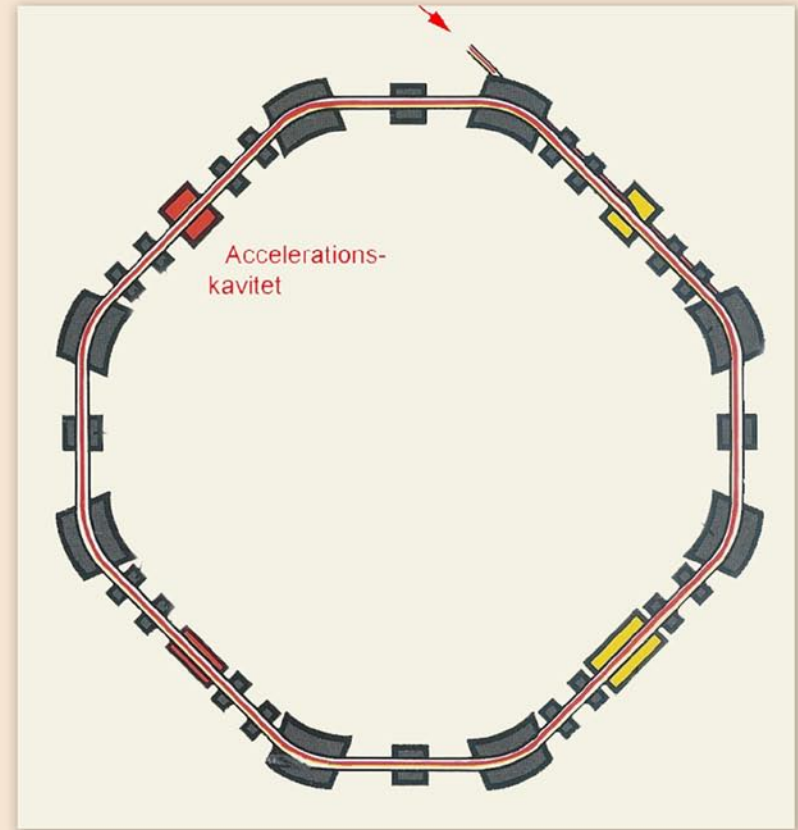

Research at LUSY

LUSY came into operation in 1962, and its operators became increasingly more knowledgeable on the operation of accelerators. A new division for research into elementary particles, using LUSY, was established by Guy von Dardel in 1965. LUSY was also used to produce pi-mesons.

Another group, led by Bengt Forkman, was working with both the 35 MeV synchrotron and LUSY to study how the nucleus was affected by the radiation resulting from the collision of electrons with material.

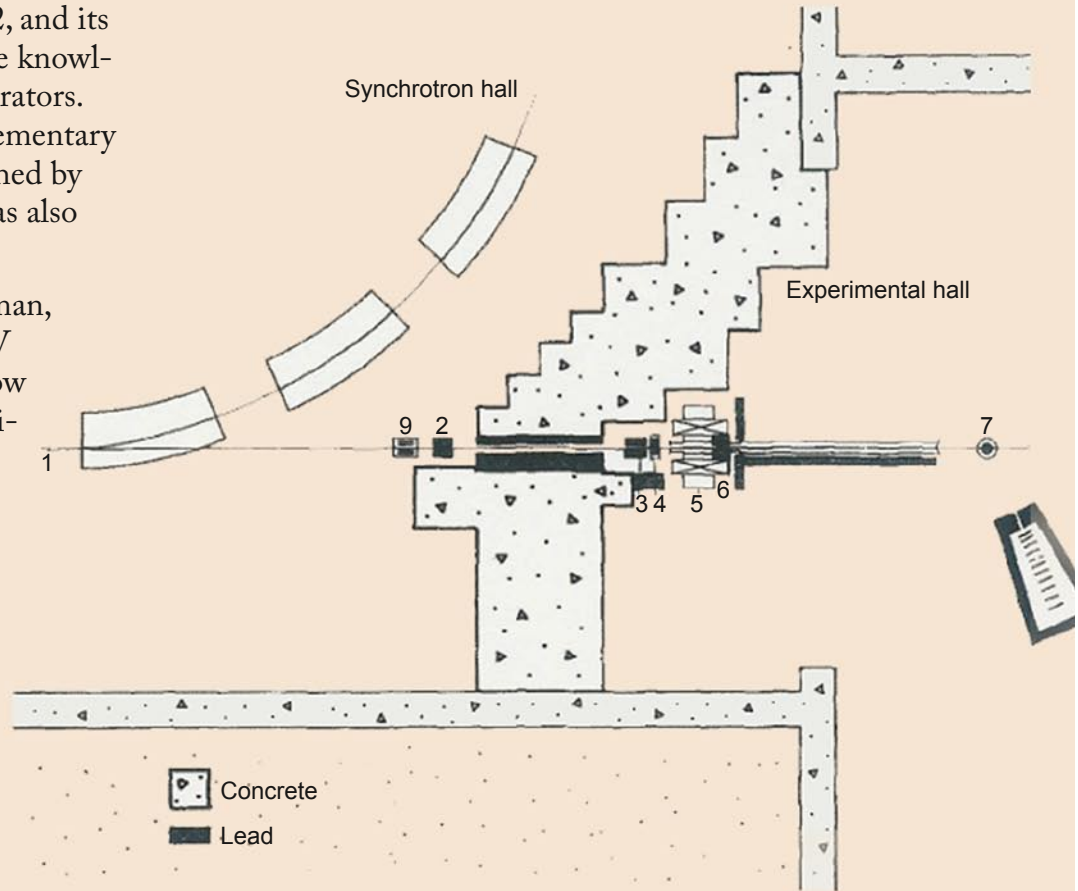

1971 – A fateful year

When discussions started on a major expansion of CERN (the European Organization for Nuclear Research, in Geneva), the question of Sweden's financial contribution to the project arose.

In 1971, it was decided that funds would be redirected from the grant for nuclear physics, and thus support for LUSY ceased.

The Accelerator Group and the Photonuclear Group had to take measures to save their activities in Lund. There was no lack of ideas, and an application to the Council for Atomic Research, signed by Bengt Forkman and the operational manager at LUSY, Rune Alvinsson, was completed at the beginning of 1974.

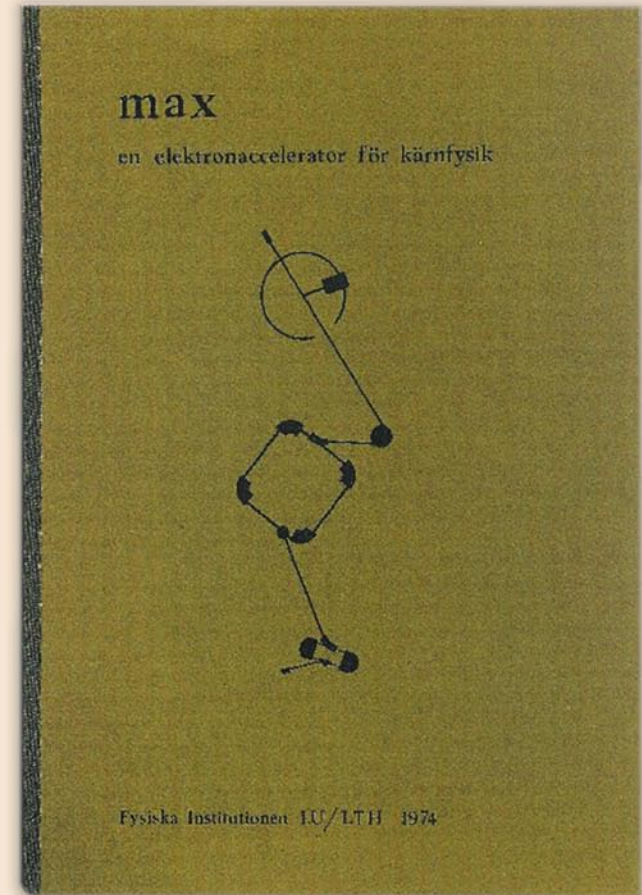

The origin of MAX

The new proposal was for a small facility for research in nuclear physics, consisting of an accelerator that could produce electrons with an energy of 100 MeV – a ring that could transform the short pulses from an accelerator to a continuous beam of electrons, and a system that could identify electrons with a specific energy for nuclear physics experiments.

The planned accelerator had been developed by Olle Wernholm, and was called a racetrack microtron, as the electrons moved in a path similar to a racetrack.

The name of the new accelerator, MAX, is derived from Microtron, Accelerator, and the fact that the circulating electrons emit X-rays.

100 MeV Microtron

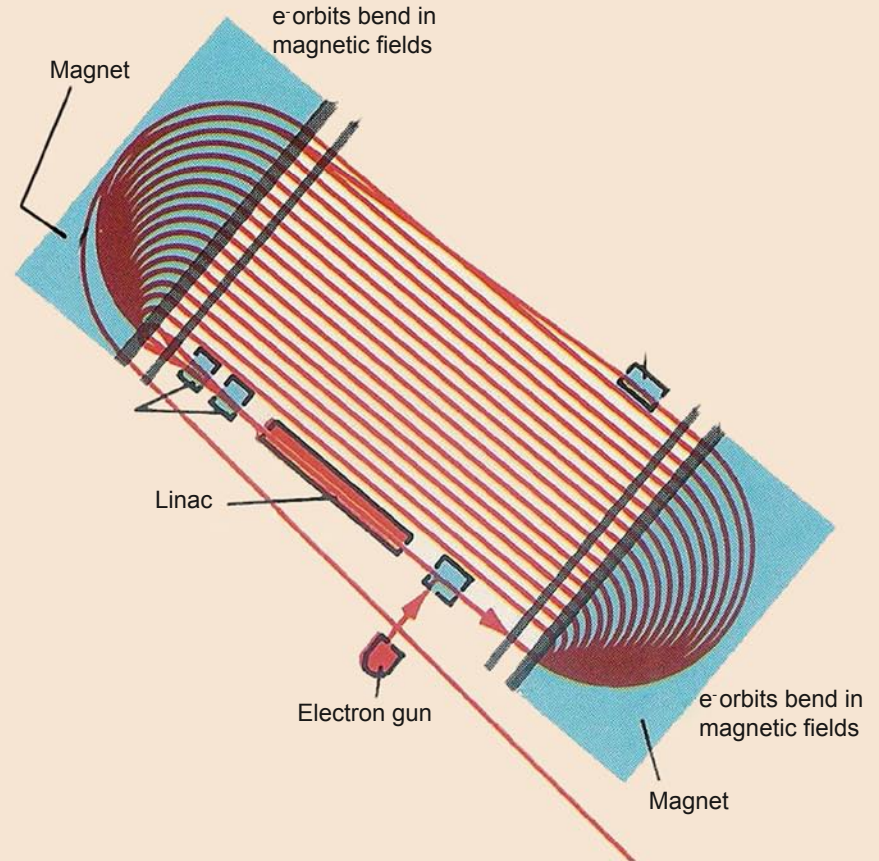

A bright idea

Initially, it was intended that the MAX project would involve only nuclear physics, but researchers in material physics, PO Nilsson from Gothenburg and Anders Flodström in Linköping, suggested early on that perhaps MAX could be used to produce synchrotron radiation.

Mikael Eriksson, who had been the technical director of MAX-lab since the beginning, investigated this possibility, and the MAX project was expanded to include research using synchrotron radiation. The storage ring was designed to increase the energy of the electrons to 550 MeV.

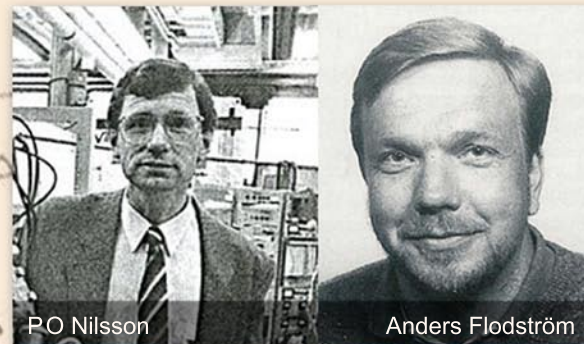

PO Nilsson

Anders Flodström



Mikael Eriksson

Synchrotron radiation

An electron that is accelerating, for example, oscillating in a radio antenna, emits electromagnetic waves. An electron moving in a synchrotron ring also emits radiation, in the same way, when it is bent by the magnetic field.

When the velocity of the electrons is close to that of light, the radiation is emitted in a narrow bunch, containing all frequencies and wavelengths, from the infrared, via visible light, to the ultra-violet, and into the X-ray region.

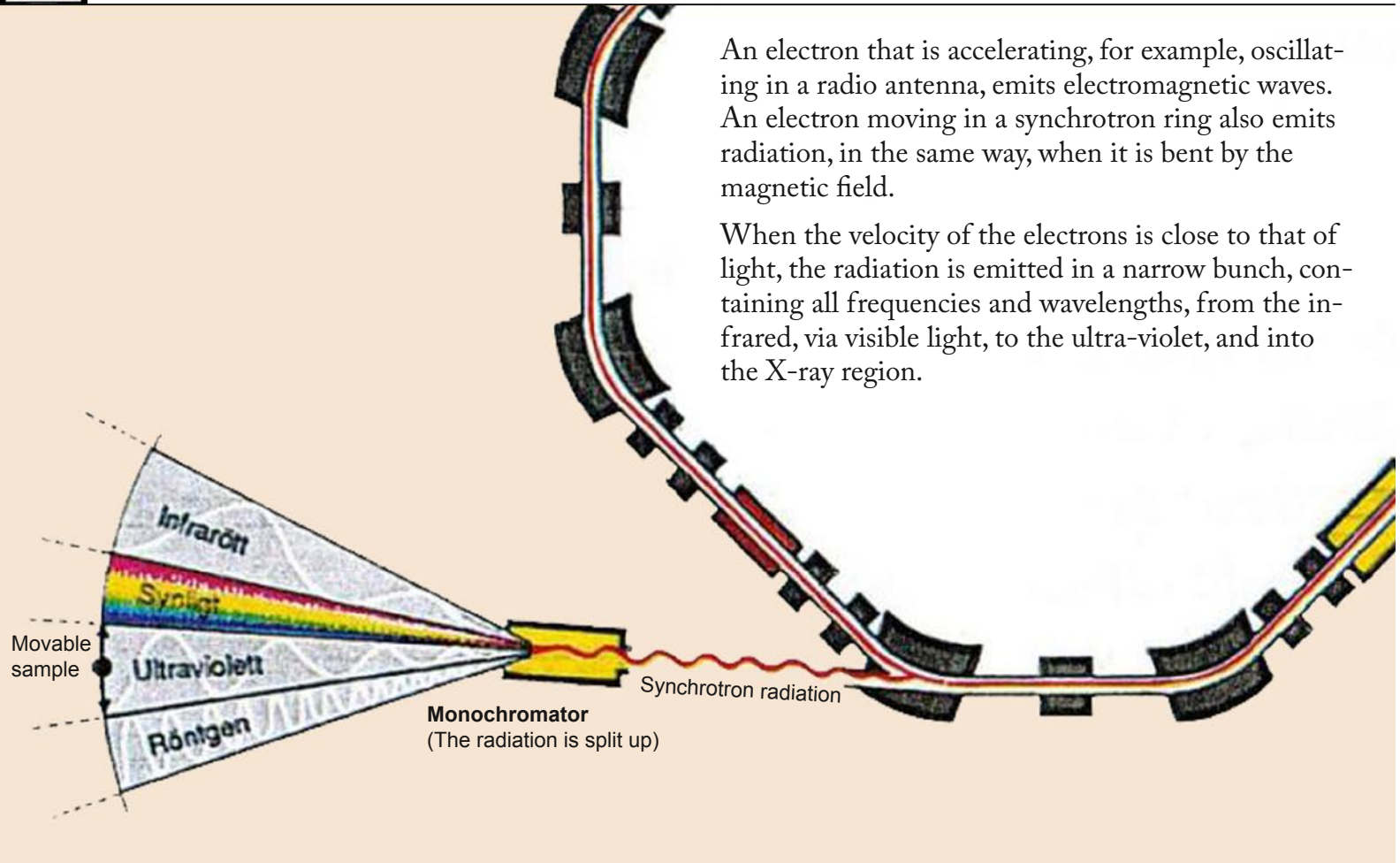

Undulators



Undulator from MAX III.

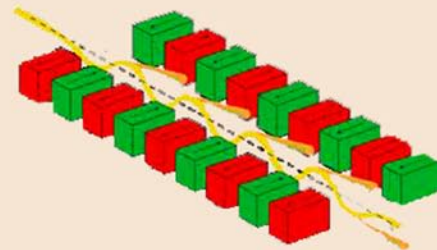

The fact that synchrotron radiation has a high intensity over an extremely broad frequency range makes it useful in widely varying areas of research.

The intensity of the radiation can be increased using an undulator, in which the electrons pass through a magnetic field with alternating polarity. This will cause the electrons to oscillate, emitting radiation from each undulation.

When the distance between the magnets is suitably adjusted, the radiation will interfere, leading to higher intensity in a narrow frequency interval.

MAX I

This change in plans led to a change in the appearance of MAX. The electrons are first accelerated in a racetrack microtron, before being injected into the 9.2 m diameter storage ring. The circular path is obtained using eight magnets, and every time the beam is bent, radiation is emitted. Along a small part of the ring, the energy of the electrons is increased to its maximum: 550 MeV. In another part of the ring there is an undulator.

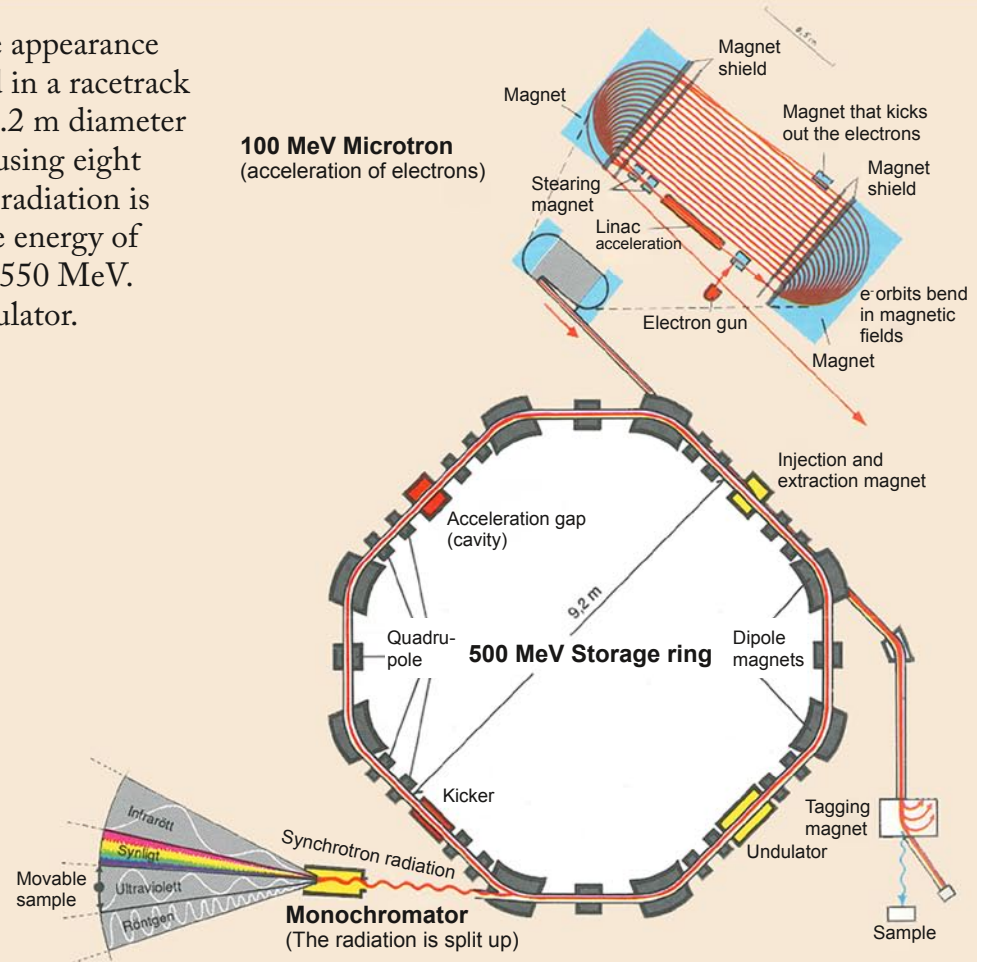

Experimental nuclear physics was performed, up until spring 2015, in a separate laboratory using electrons from the ring.

Do-it-yourself

In order to reduce the cost of the project, and to ensure a high degree of flexibility, most of the components for MAX were constructed originally at the Department of Physics, and later at MAX-lab.

This was possible thanks to ten years' experience of running and refurbishing LUSY. The entire project was led by Bengt Forkman, together with the technical director, Mikael Eriksson, and Leif Thånell, who was head of engineering.

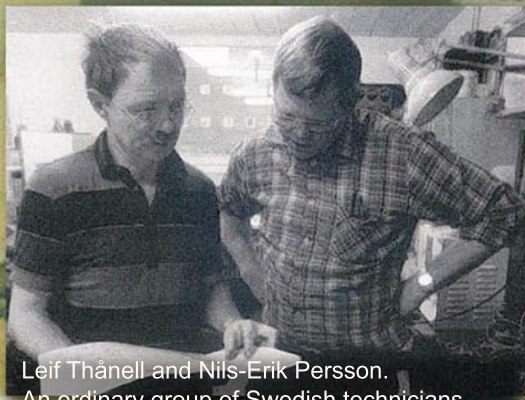

Leif Thånell and Nils-Erik Persson.
An ordinary group of Swedish technicians,
dedicated and loyal to the task, built MAX-lab.

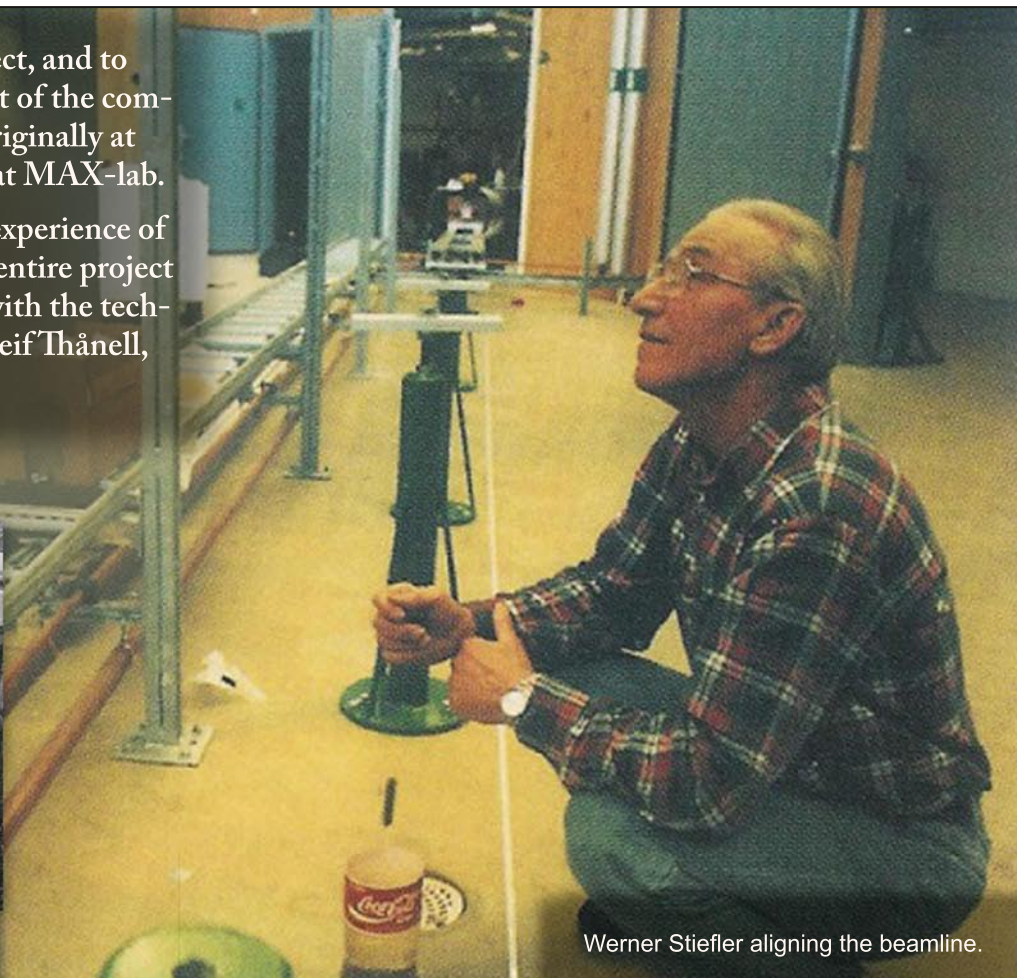

Werner Stiefler aligning the beamline.

MAX leaves home!

Sensational news! MAX-lab moves into new premises at LTH. *It will be a great success*, says Bengt Forkman.

The large photo shows the same place ten years later.

In 1981, MAX-lab became an independent research facility, with its own board and director. The main reason for this was to promote it as a national laboratory.

At about the same time, The Swedish Scientific Research Council (NFR) decided to make research with synchrotron radiation an area of high priority. This idea was embraced by Lund University, and a large experimental hall at the Faculty of Engineering (LTH) was made available for the accelerator.



MAX grows up



MAX II was inaugurated on 15th September 1995 by the Swedish King Carl XVI Gustaf.

Ingolf Lindau, the director from 1991 to 1997, can be seen here together with the King.

Even before MAX started to produce synchrotron radiation in 1986, Mikael Eriksson and Anders Flodström had started to plan the further development of MAX to produce higher energies, and thus greater intensities and shorter wavelengths. In 1991 the NFR decided to support a project to build a 30 m diameter ring, producing energies of up to 1500 MeV. The project was called MAX II.

The new project required even larger premises, and the new 4000m² building was completed in February 1993.

MAX-lab

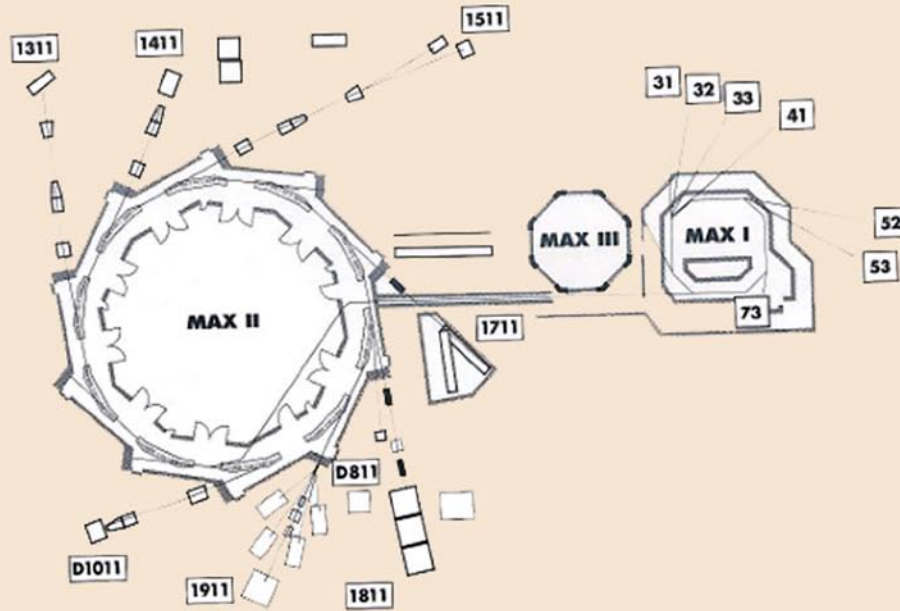

The accelerators at MAX-lab consisted of three electron storage rings (MAX I, MAX II and MAX III) and a pre-acceleration stage (MAX injector). MAX III was a 700 MeV ring built in 2007 to relieve user pressure on MAX II. It was also being used to test new technology in the construction of MAX IV.

All three rings produced synchrotron radiation for experiments and measurements in various areas of research in, for example, physics, chemistry, materials science, bio-chemistry and medicine, and were used by research groups from many countries.

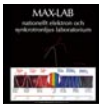

The rings construction

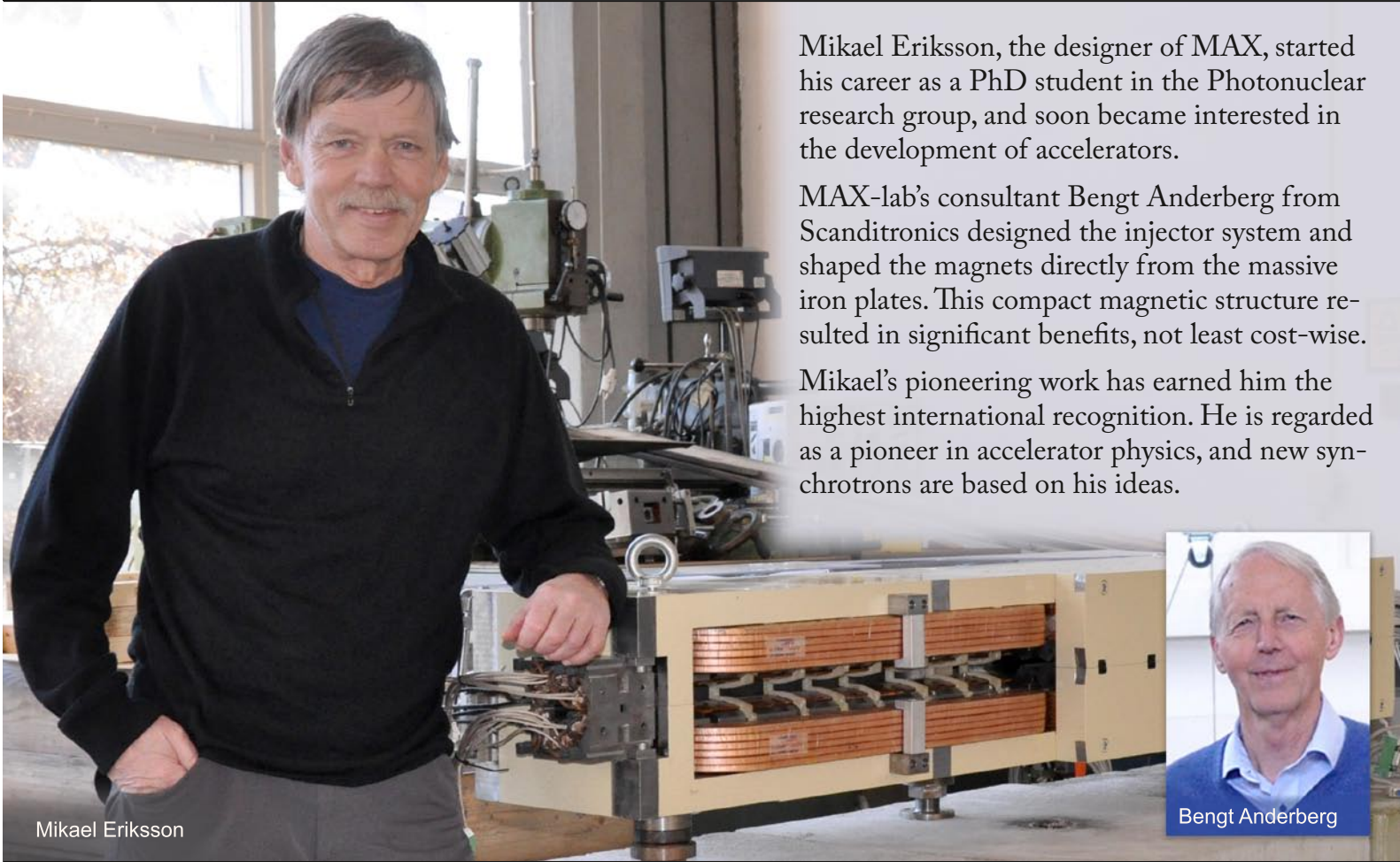

Mikael Eriksson

Mikael Eriksson, the designer of MAX, started his career as a PhD student in the Photonuclear research group, and soon became interested in the development of accelerators.

MAX-lab's consultant Bengt Anderberg from Scanditronics designed the injector system and shaped the magnets directly from the massive iron plates. This compact magnetic structure resulted in significant benefits, not least cost-wise.

Mikael's pioneering work has earned him the highest international recognition. He is regarded as a pioneer in accelerator physics, and new synchrotrons are based on his ideas.



Bengt Anderberg



The future of MAX

MAX IV was inaugurated 21st of June 2016.

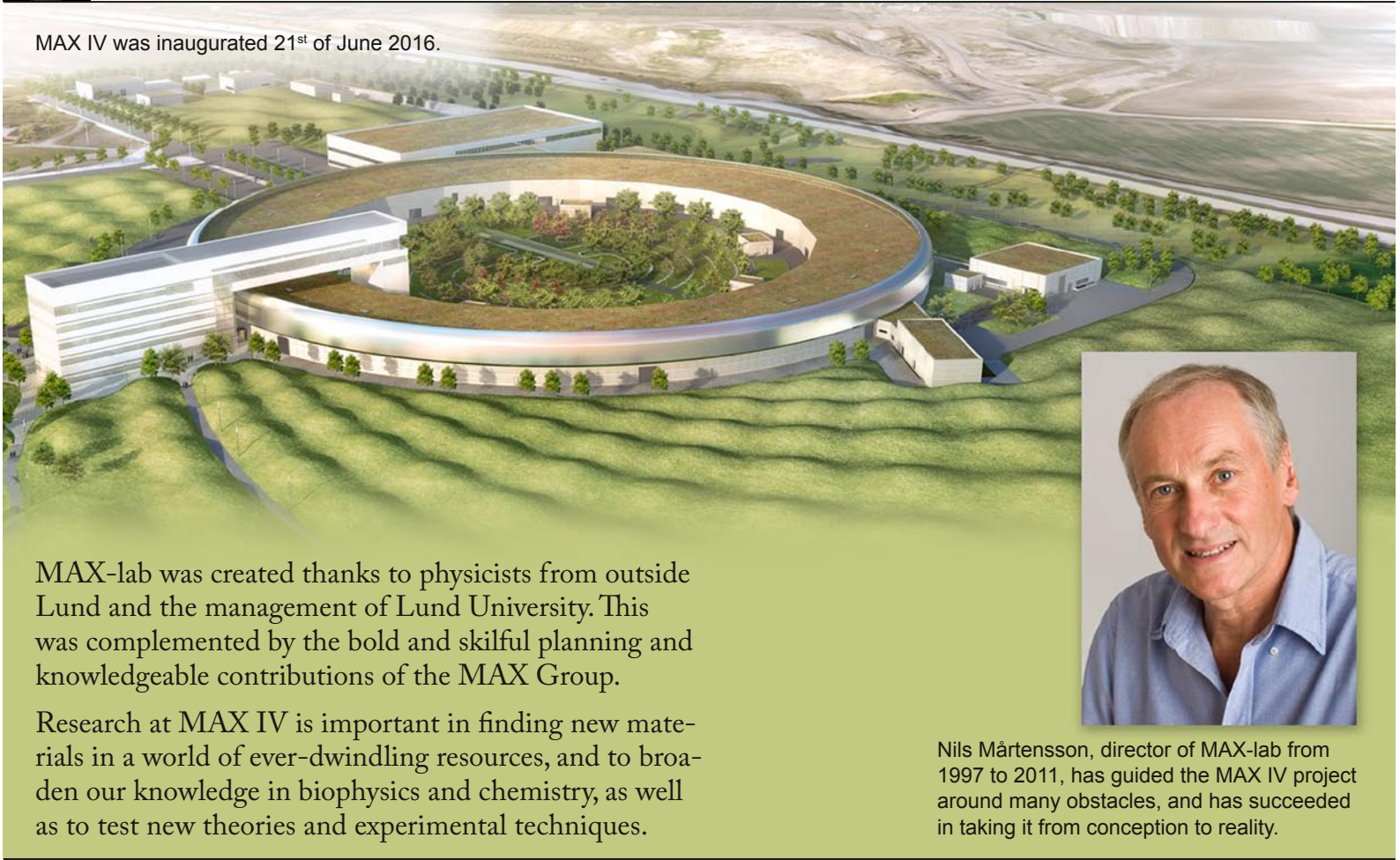

MAX-lab was created thanks to physicists from outside Lund and the management of Lund University. This was complemented by the bold and skilful planning and knowledgeable contributions of the MAX Group.

Research at MAX IV is important in finding new materials in a world of ever-dwindling resources, and to broaden our knowledge in biophysics and chemistry, as well as to test new theories and experimental techniques.

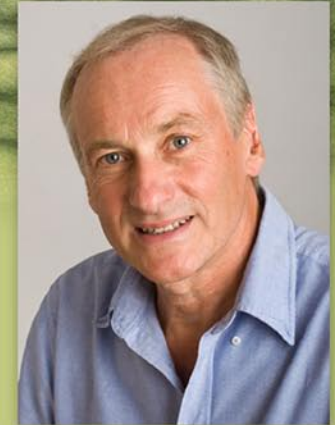

Nils Mårtensson, director of MAX-lab from 1997 to 2011, has guided the MAX IV project around many obstacles, and has succeeded in taking it from conception to reality.



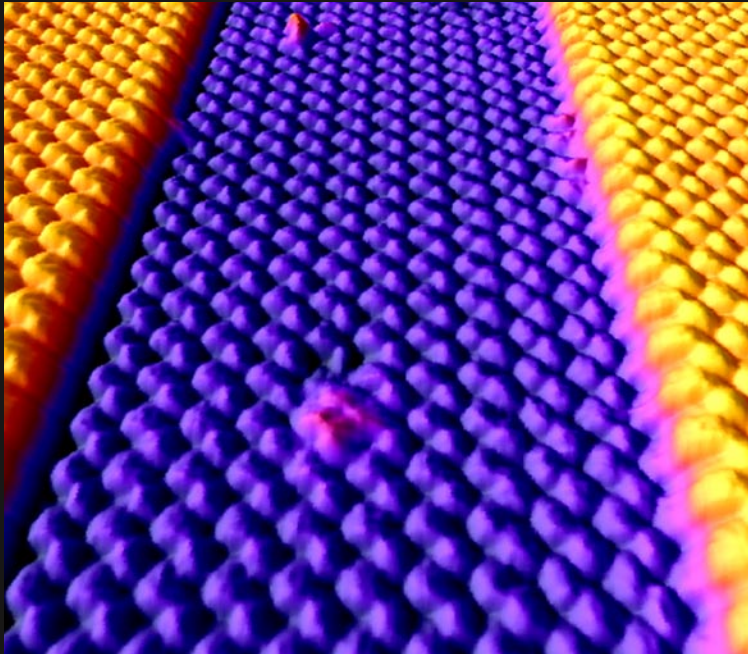

The synchrotron light from Lund

The story of how physicists in Lund
learned to use synchrotron light.

The brilliant light

The development of the famous equations linking electricity and magnetism by James Clerk Maxwell in 1873, signalled the end of the epoch of classical physics and heralded the age of quantum mechanics.

Fourteen year later, Heinrich Hertz showed that flowing electric currents caused magnetic fields that radiated with the velocity of light. This formed the basis for synchrotron radiation.

The general theory of electromagnetic radiation was found to be complicated. In 1898, one year after the discovery of the electron, Alfred Liénard wrote his treatise on *electric and magnetic fields*.

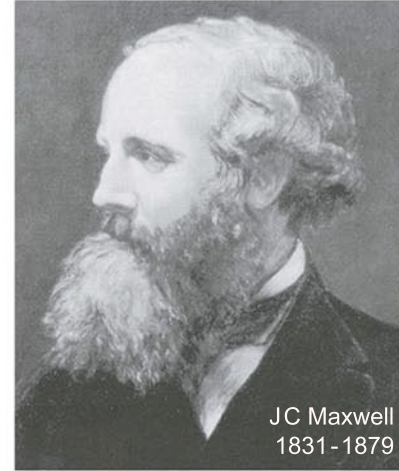

JC Maxwell
1831 - 1879



Alfred-Marie Liénard
1869 - 1958

$$\begin{aligned}\nabla \times \mathbf{E} &= -\partial \mathbf{B} / \partial t \\ \nabla \times \mathbf{H} &= \mathbf{J} + \partial \mathbf{D} / \partial t \\ \nabla \cdot \mathbf{D} &= \rho \\ \nabla \cdot \mathbf{B} &= 0\end{aligned}$$

Maxwell's equations.

Synchrotron radiation is a relativistic effect

Albert Einstein formulated his theory of special relativity in 1905. This allowed Liénard's calculations to be further developed by G A Schott in 1912.

He arrived at the following conclusions:

- a) An electron travelling in a circular path emits radiation. If the velocity of the electron is low, the radiation will be emitted isotropically (in all directions). The intensity of the radiation will be higher towards the outer edge of the path, and lower towards the centre. The radiation will be monochromatic (of a single wavelength).
- b) As the velocity of the electron approaches that of light, the radiation will become unidirectional (in one direction). It will be concentrated to a small cone, and contain all wavelengths.

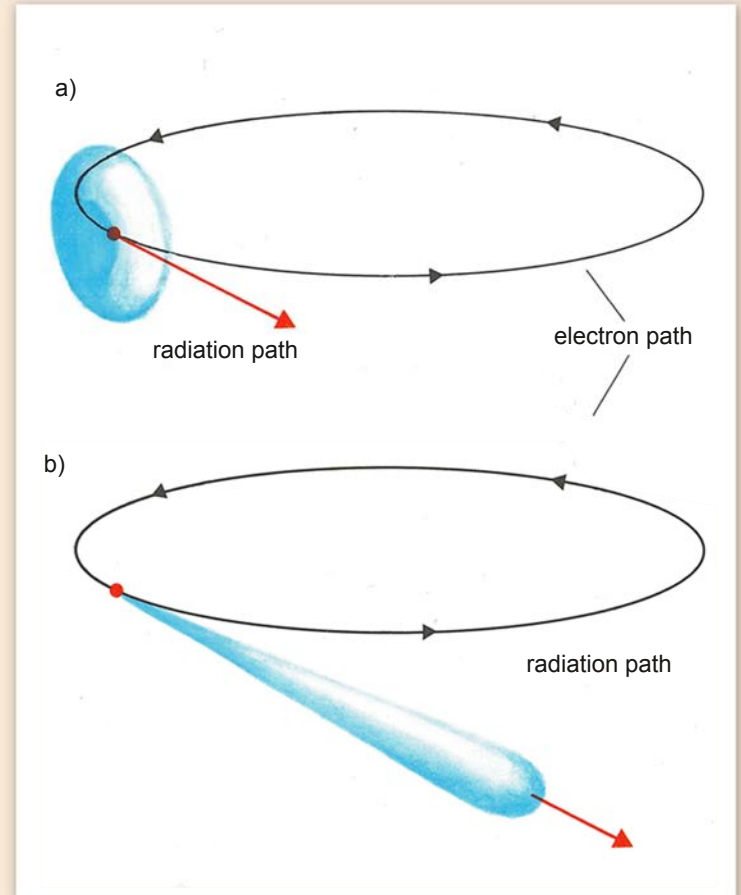

The pioneers

Accelerators for charged particles were developed in the 1930s. The first to produce a working electron accelerator was DW Kerst, who presented a 2 MeV betatron in 1941, based on a transformer. JP Blewett was aware of Schott's calculations on the emission of electromagnetic radiation, and observed that the circumference of the electron paths decreased as a result of this radiation.

This became clearer in spring 1947, when a technician working on a 70 MeV betatron noticed an intense beam of light leaving the beamline in a tangential direction. Synchrotron radiation had been discovered!

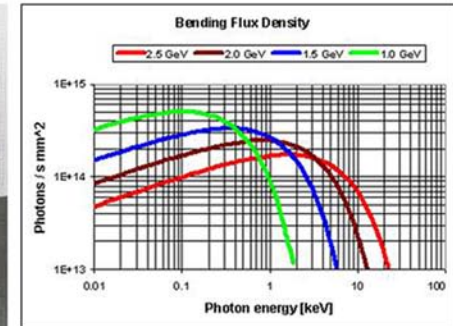

Synchrotron radiation spectra from various kinds of electron paths. The most commonly cited theoretical work on synchrotron radiation was presented by J Schwinger (1918- 1994).

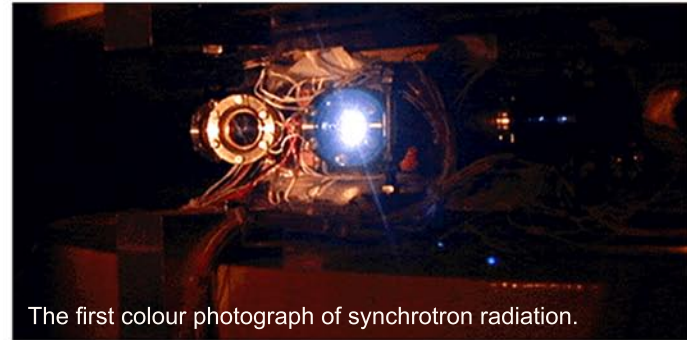

The first colour photograph of synchrotron radiation.

The MAX project

The Swedish synchrotron radiation laboratory MAX-lab is located in Lund. The project started in 1973 as a nuclear physics project, and five years later had developed to include a synchrotron light source.

100 MeV Microtron
(acceleration of electrons)

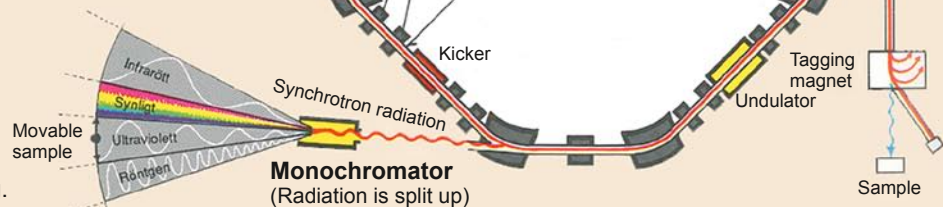
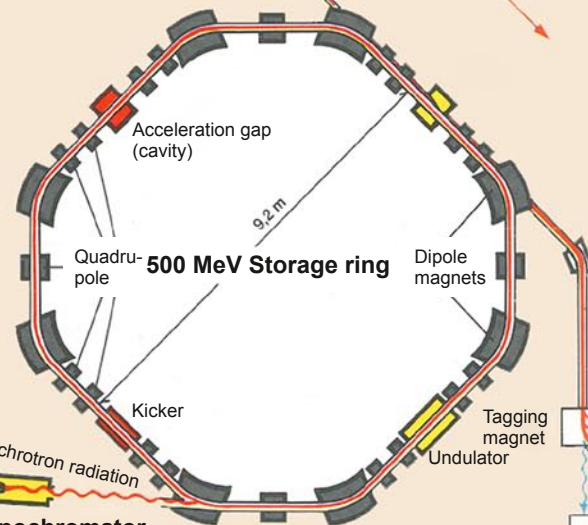
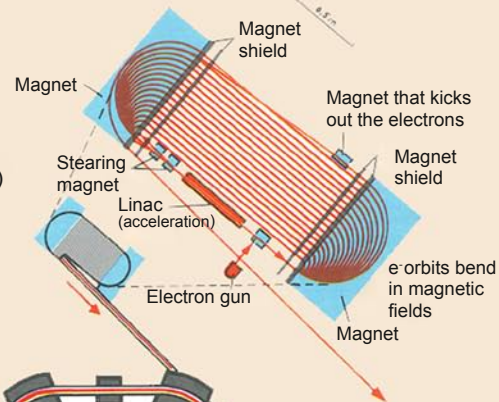

Sketch of the MAX I ring.

The inception of MAX-lab

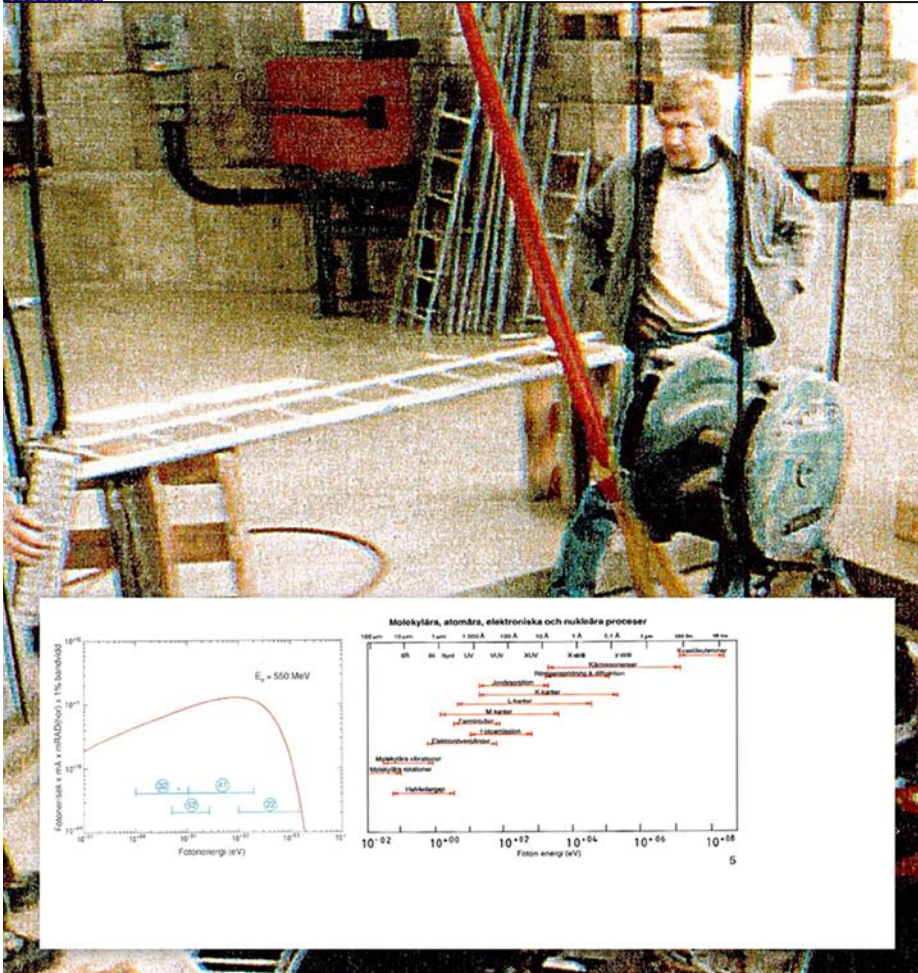

Although no research was being carried out in synchrotron radiation physics in Lund, a research position was established, and Anders Flodström from Linköping/Stanford (USA) took up the position.

He had plenty of new ideas and was a successful entrepreneur, being one of the main applicants responsible for equipping the synchrotron with scientific equipment, with the objective of developing a national research centre.

All the Swedish research groups in this field were welcome to use the equipment.

Anders Flodström
Senior lecturer in synchrotron radiation physics from 1981 - 1985, later Professor, Faculty Dean and the Vice-Chancellor of two Swedish Universities.

A national facility

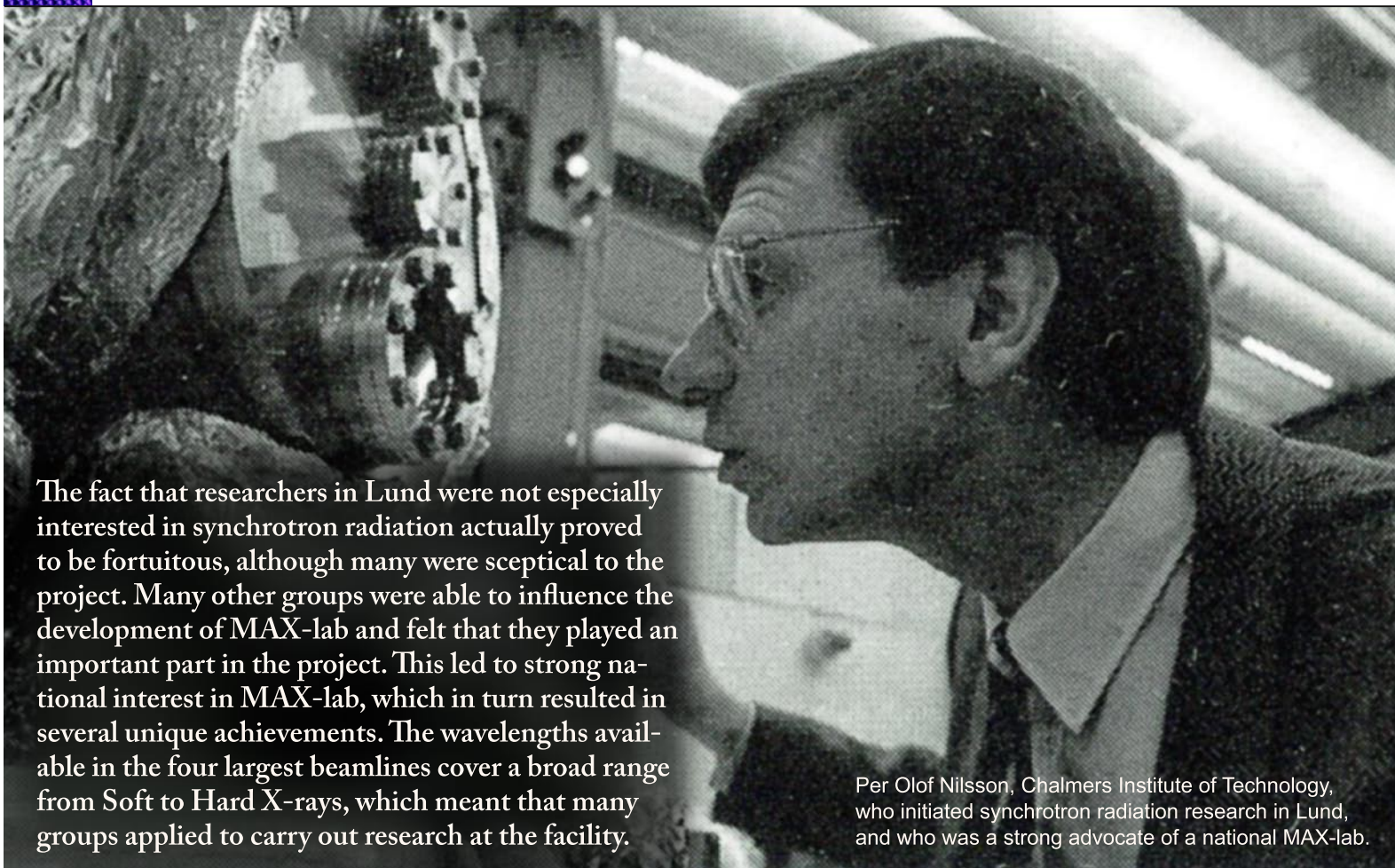

The fact that researchers in Lund were not especially interested in synchrotron radiation actually proved to be fortuitous, although many were sceptical to the project. Many other groups were able to influence the development of MAX-lab and felt that they played an important part in the project. This led to strong national interest in MAX-lab, which in turn resulted in several unique achievements. The wavelengths available in the four largest beamlines cover a broad range from Soft to Hard X-rays, which meant that many groups applied to carry out research at the facility.

Per Olof Nilsson, Chalmers Institute of Technology, who initiated synchrotron radiation research in Lund, and who was a strong advocate of a national MAX-lab.

Researchers from far and wide

In 1980 Lund University offered well-equipped premises for the MAX project. The accelerator was commissioned in 1986, and the lab was inaugurated the following year.

Sixteen synchrotron radiation projects were described in MAX-lab's first annual report in 1987. One of these was a report by two young scientists, Ulf Karlsson from MAX-lab and Roger Uhrberg from Linköping, on highly resolved electron levels in the Au/Si (111) interface. By this time, Anders Flodström had left MAX-lab and been replaced by Ralf Nyholm from Uppsala.

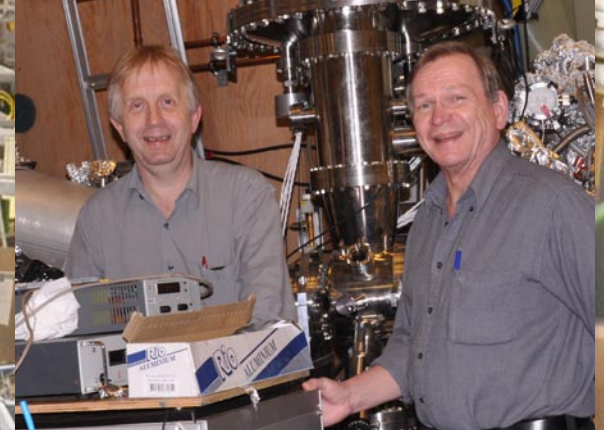

Jesper Andersen and Ralf Nyholm. Jesper came from Denmark and was one of the first researchers at MAXI. He is now Scientific Director of MAXIV.



Let there be light!

Mikael Eriksson and Anders Flodström, two very creative scientists, had already drawn up ideas for a Nordic 2.5 GeV synchrotron light source in 1985, before the MAX project was initiated. They called their project Super MAX. At the same time, the Swedish Natural Science Research Council (NFR) was engaged in making a decision as to whether Sweden would participate in the ESRF (European Synchrotron Radiation Facility).

After much deliberation and informal discussions in 1988, the NFR rejected the Super MAX project but decided to support a 1.5 GeV machine (soon called MAX II).

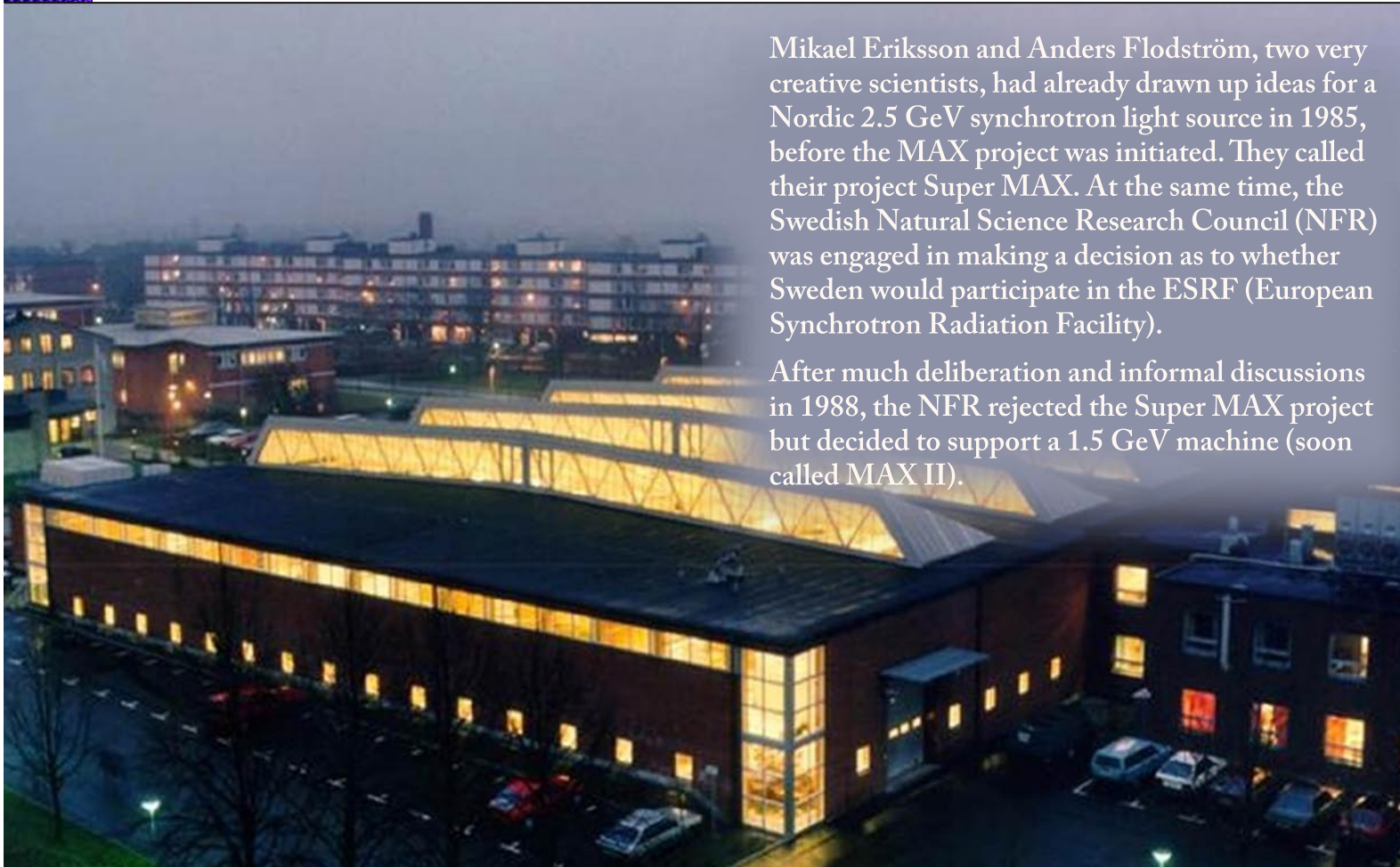
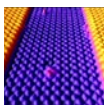

Competence begets competence

At about this time (September 1988 - August 1989) Ingolf Lindau was on sabbatical leave from Stanford, at the MAX-lab in Sweden. This would prove to be extremely important for MAX-lab's future.

Lindau was a synchrotron radiation researcher of high international repute, and was just the person to formulate the application for MAX II.

Lund University had applied for a professorship in synchrotron radiation physics in 1986. This was approved in July 1988, and Ingolf Lindau was appointed to the position in 1990.

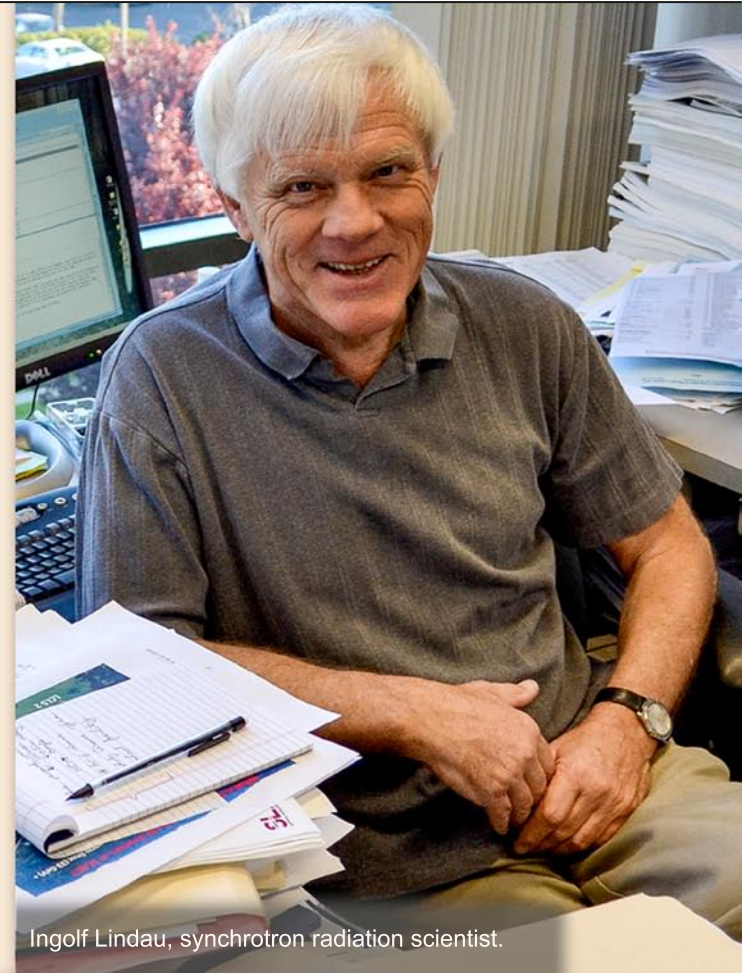

Ingolf Lindau, synchrotron radiation scientist.

Royal splendour



Ingolf Lindau talking to the Swedish King Carl XVI Gustaf.

Ingolf Lindau's task was two-fold: To steer the MAX II project to completion and to build up a research department. He was successful in both, and by 1997, when he ceased to be director, the old and the new storage rings were equipped with 16 beamlines. He also developed and installed a number of wigglers and undulators.

Ingolf left behind him a research group consisting of 17 members, that had carried out research of the highest quality. An international assessment group had nothing but praise and admiration, and described the achievement as heroic.

Photoelectron spectroscopy

The Nobel Prize in Physics was awarded to Kai Siegbahn in 1981 for his work on photoelectron spectroscopy, and this paved the way for the new Division for Synchrotron Radiation Research in 1990.

Ralf Nyholm and Jesper Andersen were studying surface properties and surface chemistry, for example, the adsorption of carbon monoxide (CO) on a crystalline surface of rhodium (Rh). At low levels of CO they observed only one peak (the carbon 1s peak), which resulted from the binding of CO directly to a Rh atom on the surface of the crystal. However, at higher levels of CO they saw a second peak, which they interpreted as being due to binding to a vacancy in the Rh surface.

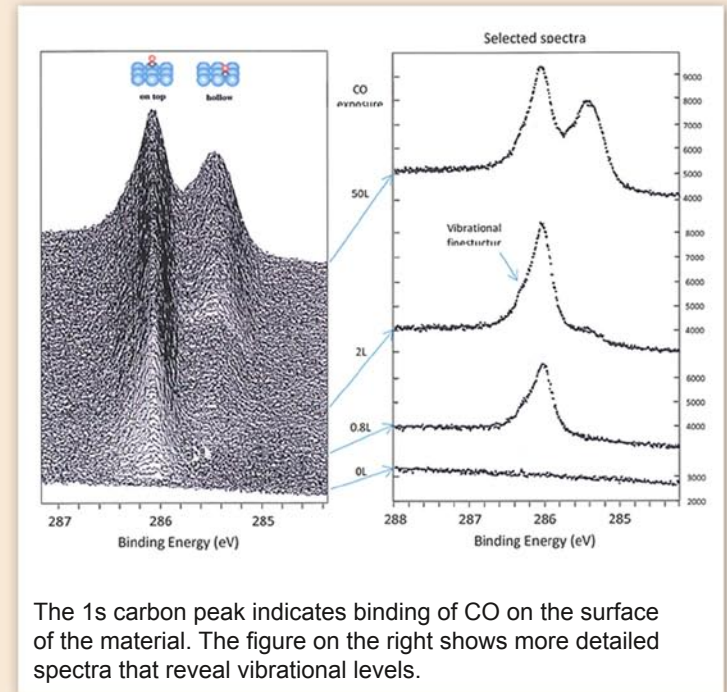

The 1s carbon peak indicates binding of CO on the surface of the material. The figure on the right shows more detailed spectra that reveal vibrational levels.

Molecular and cluster research at MAX-lab

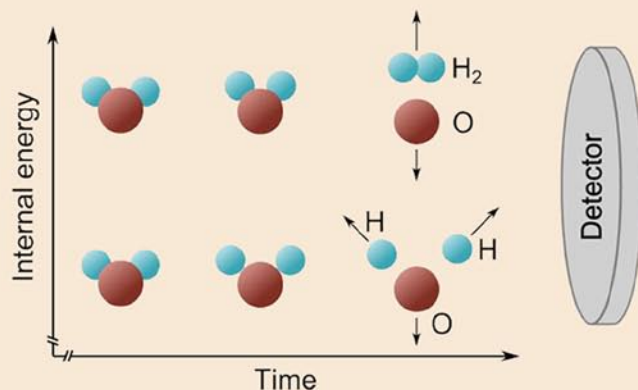

This example shows how the geometry of a water molecule is changed by electron decay which affects the molecular orbitals creates bonds between the atoms.

Stacey Ristinmaa Sörensen was interested in the dynamics of material at very low densities when irradiated with synchrotron radiation, and was looking for answers to question such as: How does this material react to synchrotron radiation?, How fast are the chemical reactions that are initiated?, and How do free nanoparticles and clusters behave?

By using short-lived electronic states as a clock, her research group, collaborating with other Swedish research groups in molecular physics and quantum chemistry, was able to follow the dynamics of the molecules on timescales of 10^{-15} seconds.



Stacey Ristinmaa Sörensen, head of the Division for Synchrotron Radiation Research.

Surface Catalytic Experiments



Joachim Schnadt,
Professor in synchrotron-radiation-based
in situ electron spectroscopy.

1s electron spectra from oxygen show how
carbon dioxide is created by catalysis when
oxygen (red peaks) and CO react strongly at
the platinum surface at high temperatures.
This was confirmed using mass spectrometry

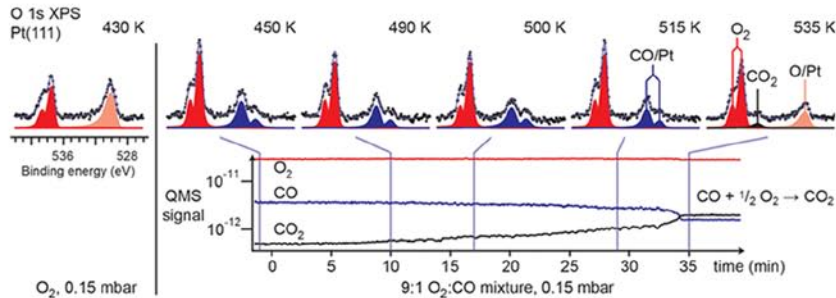

The experiment reveals a new carbon dioxide gas phase peak at temperatures around 535 K.

The use of electron spectroscopy is limited in high-pressure surface catalytic experiments as the former can only be carried out at very low pressures. The high brilliance of synchrotron radiation allows this problem to be overcome and in situ experiments to be performed. The technique was developed by Joachim Schnadt. Together with his research group at MAX II, he has studied how the surface of platinum reacts with a mixture of carbon monoxide and pure oxygen. At elevated temperatures, the CO is oxidized to CO₂.

Catalysis and electrochemistry

Hard X-rays (25 - 85 keV) from synchrotron radiation sources are highly suitable for studying materials and processes on the atomic scale in environments where they are used commercially.

Using the results of basic research on the surface properties of materials, the Division for Synchrotron Radiation Research has developed new methods based on interference and diffraction. These will help improve our understanding of modern materials that are already in use, or will be used in the future, in catalysis, electrochemistry and crystal growth.

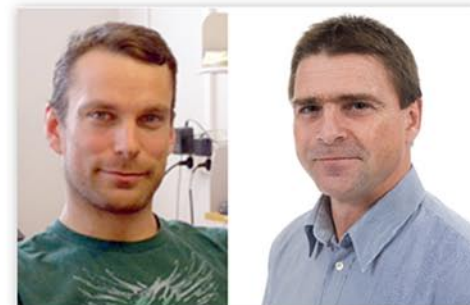

Researchers in synchrotron radiation
Johan Gustafson och Edvin Lundgren

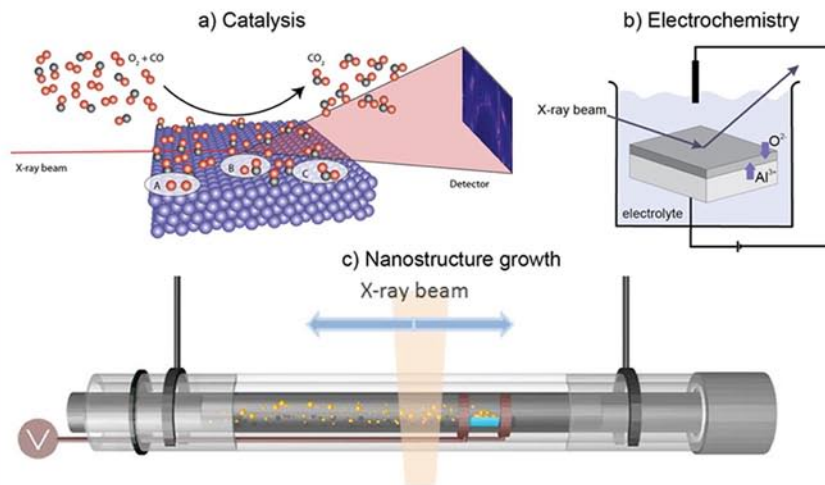

Surface structure on the atomic scale

The 1986 Nobel Prize in Physics was awarded to the inventors of scanning tunnelling microscopy. With this technique it is possible to see how individual atoms are arranged on a surface, for example nanowires. The surface area of a nanowire is important for its properties as nanowires consist almost only of a surface. Nanowires are typically a few micrometres long and a few tens of nanometres thick, and are useful in electronics, solar cells and LEDs.

Researchers at Lund University under the leadership of Lars Johansson were the first in Sweden to use this kind of microscopy, and a great deal of research concerning nanowires is performed at the Department of Physics.



Anders Mikkelsen
Synchrotron radiation researcher.
From nanowires (a) to single atoms (d).

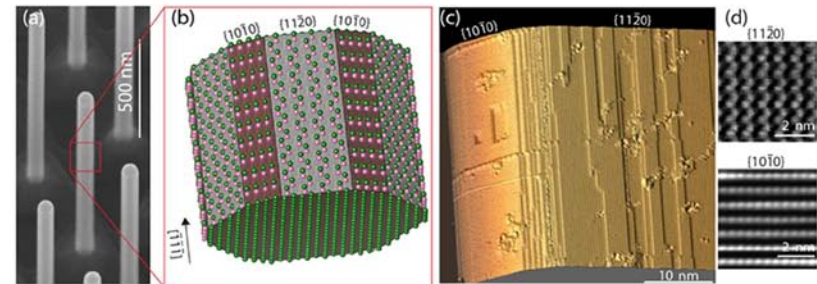

Research in Time and Space



Synchrotron radiation researcher
Mathieu Gisselbrecht.

Two-electron wave function created in xenon atoms by short laser pulses in the attosecond lab.

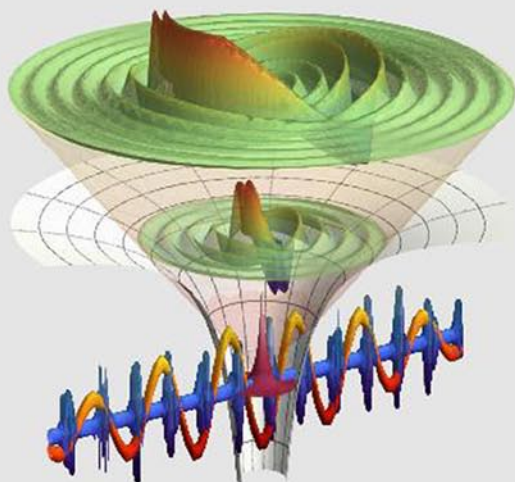

Two of the division's experimental areas, spectroscopy and microscopy, developed in parallel, and both have proven to be a good basis for collaboration with other research groups in the department: The Attoscience Group at the Division of Atomic Physics, and the Nanometer Consortium at the Division of Solid State Physics.

Rapid events are initiated in atomic wave functions, molecules and on the surface of materials by excitation with short laser pulses, and the processes are studied using spectroscopy.

Mathieu Gisselbrecht's much-noted time-resolved measurements on xenon show that electrons are emitted at intervals of a few hundred attoseconds during double ionization.



Combustion physics

How a Master's project in combustion diagnostics led to a new division at the Department of Physics and together with other divisions at LTH formed the Thulin Laboratory.

The nature of fire



Antoine Lavoisier (1743-1794)
and his wife Marie Anne Pierrette Paulze (1758-1836).



The four elements proposed by the ancient Greeks, some of which remain to be characterized in detail. What is the composition of the interior of our planet? Why does the earth have an atmosphere? When was water formed on earth? Why does combustion take place? What exactly is fire? We only have partial answers to these questions.

According to the ancient Greek philosophers, fire was one of the four elements that, together with earth, water and air, made up the universe. The notion of fire as a basic element persisted, and during the 18th century was known as phlogiston.

The French chemist Antoine Lavoisier and his wife and collaborator Marie Anne Pierrette Paulze carried out accurate experiments in which they measured the total weight of fuel and air, and found it to be the same as the total weight of the ash and gases formed by combustion. They therefore came to the conclusion that combustion was a chemical reaction, and the notion of phlogiston was disproved.

Combustion

Combustion may appear to be a simple process when expressed as below:

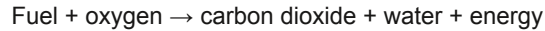

In reality, it is a much more complicated process. In order to study combustion in detail, it is necessary to be able to make measurements on the time scale of 10^{-15} seconds (femtoseconds) and below. It has only become possible during the past few decades, thanks to the development of ultra-fast detection systems, to study the hundreds of chemical reactions taking place when a simple molecule like methane, CH_4 , is combusted.



Diffusion flame.

The global energy supply

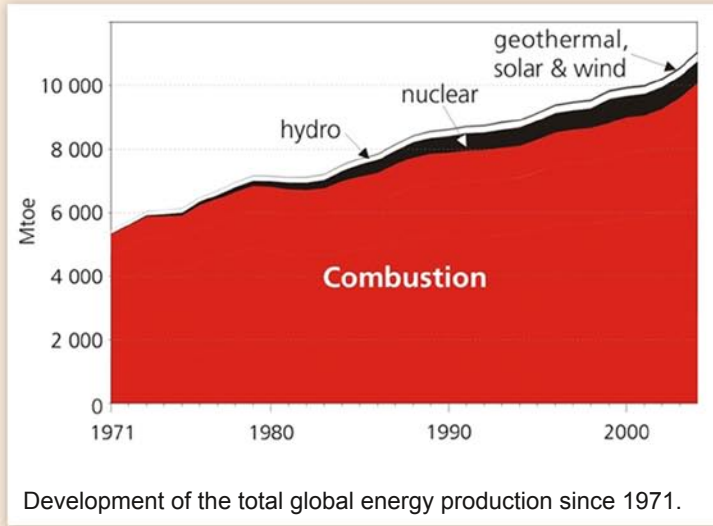

Today, over 80% of global energy is supplied by combustion. Combustion affects most aspects of our daily life, for example, heating, transport (by road, rail and air) and the incineration of waste.

The aim of combustion research is to optimize the combustion process so as to minimize the amount of fuel required and the release of CO₂ and other by-products.

Combustion research

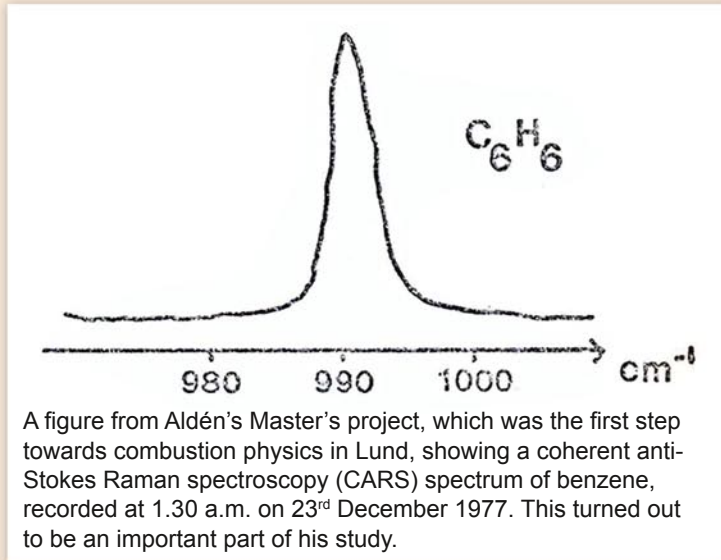

Combustion takes place at high temperatures and pressures, and it is thus important to understand the interaction between chemistry and turbulent flow, and how pressure affects the process. The questions that need to be answered are: What should we measure and simulate? How can we make such measurements? How can we simulate the process?

Combustion research at Lund is based on a Master's project carried out by Marcus Aldén, a former student at Chalmers University of Technology, under the supervision of Sune Svanberg and Thure Högberg (Volvo). Aldén performed non-intrusive measurements using lasers to study various combustion processes.

Rapid expansion



Marcus Aldén

The combustion group expanded its activities into new areas, and the Division for Combustion Physics was founded in 1991. A professorship in laser-based combustion diagnostics was awarded to Marcus Aldén the same year.

Combustion research in Lund is characterized by collaboration between several disciplines. For example, the Lund University Combustion Centre was formed, and has had the status of a European Large Scale Facility (LSF).

The Enoch Thulin Laboratory



The Enoch Thulin Laboratory, inaugurated in 2001.

Combustion research at Lund expanded rapidly from the very beginning. Heavy equipment, including a new high-pressure combustion test rig, the only one of its kind, required a lab of its own.

The Enoch Thulin Laboratory was built at the Department of Physics and was inaugurated in 2001. This allowed most of the more fundamental combustion research in Lund to be collected under one roof, enabling closer and deeper collaboration between different departments.

The laboratory is named after Enoch Thulin (1881-1919), a pioneer aviator who obtained his PhD at Lund University.

Why laser diagnostics?

Important developments in computing power and advanced diagnostics at the turn of the century made it possible to study the combustion process in detail. Non-intrusive optical diagnostics using lasers became possible, allowing studies of the short-lived compounds that are formed during combustion under specific conditions.

It also became possible to measure temperature, flow and velocity, as well as concentrations, including soot, and particle size, with high temporal and spatial resolution. Marcus Aldén's first PhD student, Per-Erik Bengtsson, is now a professor at the division and responsible for research in a number of areas of combustion diagnostics.



Two photographs of a laminar Bunsen burner flame, without a probe (left) and with a thermo-element inserted into the flame (right) to measure the temperature at a specific point. Insertion of the probe leads to changes in the flow, causing a lowering of the temperature and changes in the chemical reactions taking place. This can be avoided by using non-intrusive laser diagnostics.

Laser-induced fluorescence – LIF

Laser radiation has many properties that make it suitable for studying combustion without interfering with the process.

In laser-induced fluorescence (LIF), the wavelength of the laser light is chosen such that it matches the difference in energy between two levels in the molecule being studied.

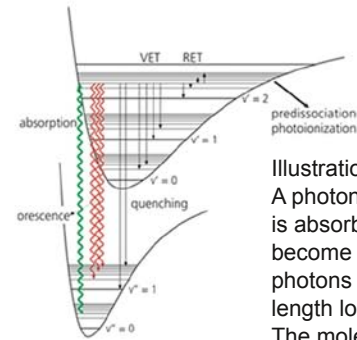
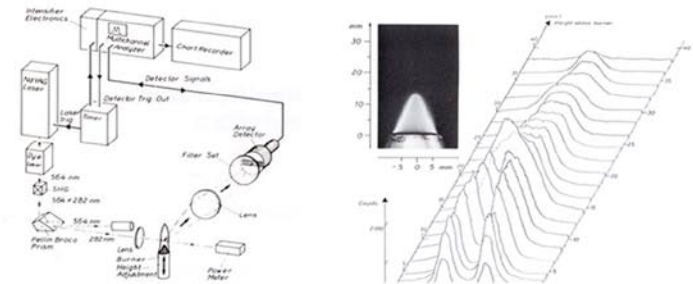
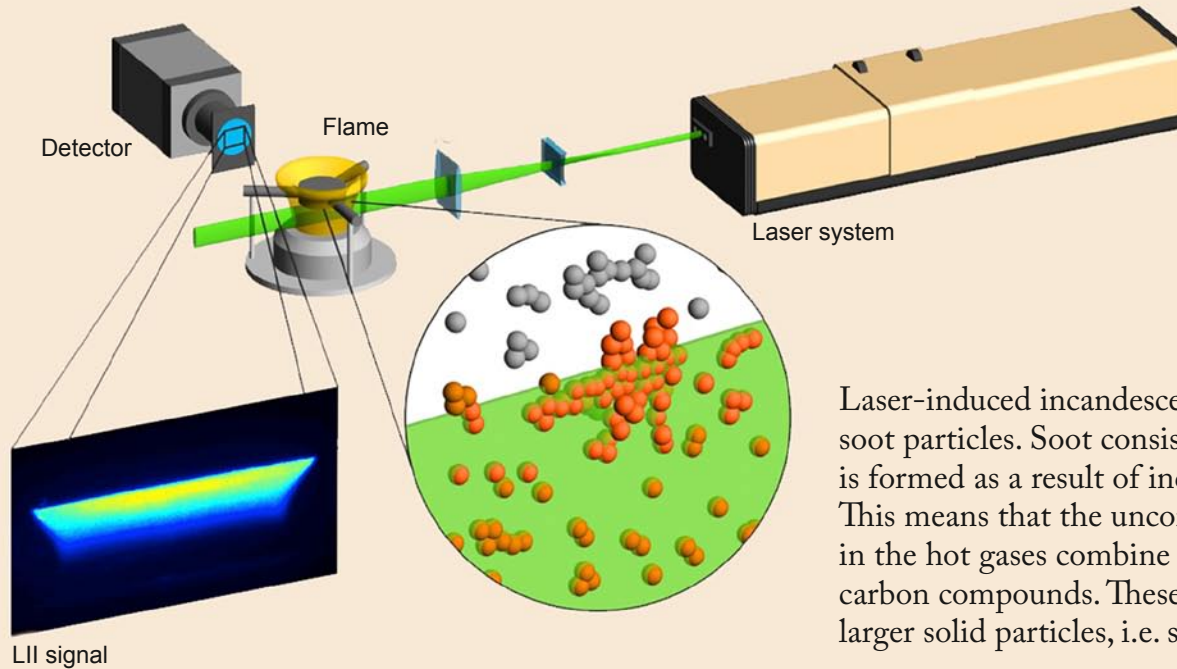

Illustration of LIF and its decay mechanisms. A photon from the laser (shown in green) is absorbed by the molecule causing it to become excited. The molecule then emits photons (shown in red), often with a wavelength longer than that of the laser light. The molecule thus returns to a lower energy level and the energy emitted is seen as fluorescence.



Spatially resolved fluorescence of OH in a flame and the distribution of OH radicals.

Laser-induced incandescence



Laser-induced incandescence (LII) is used to study soot particles. Soot consists mostly of carbon, and is formed as a result of incomplete combustion. This means that the unburnt hydrocarbons in the hot gases combine to form ring-shaped carbon compounds. These then combine to form larger solid particles, i.e. soot.

LII is used to detect the light emitted by soot particles when they are heated to a temperature of about $3500\text{ }^{\circ}\text{C}$ by laser light. The signal provides a measure of the soot concentration in the region being studied, but can also provide information on particle size.

Illustration of the measurement of soot concentration (volume fraction) in a laboratory flame.

Other laser techniques

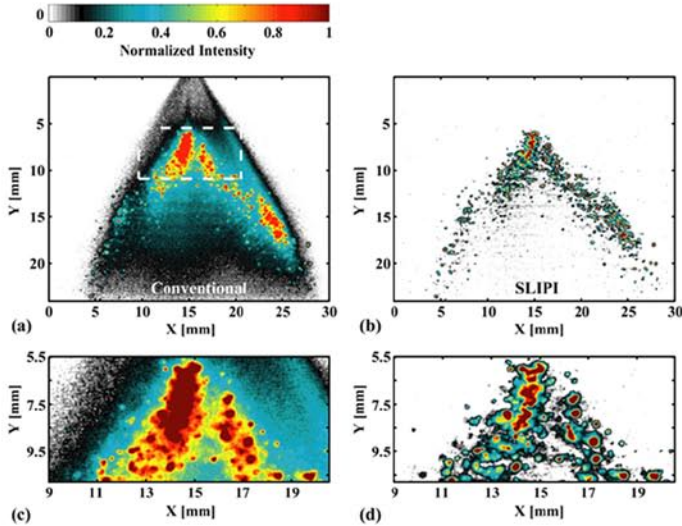

Images of sprays used, for example, in diesel engines, taken with conventional laser photography (a) and with SLIPI (b), which removes unwanted signals, such as the dark area surrounding the droplets in the left-hand figure.

New laser techniques have been developed at the Division of Combustion Physics, examples of which are CARS, in which the gas temperature can be measured accurately, and polarization spectroscopy, with which extremely small amounts of a compound can be detected in a flame.

Rayleigh scattering is used to measure temperature, structured laser illumination planar imaging (SLIPI) to study sprays and dense clouds of droplets, thermographic phosphors for measuring the surface temperature, and particle image velocimetry (PIV) for measuring flows and velocities in gas flows.

Turbulence

High-speed diagnostics is used to study the development of turbulent structures. As turbulence is a three-dimensional phenomenon, 3D measurements with high temporal resolution are needed to understand turbulent flames.

A 3D system consists of four Nd:YAG lasers and a high-speed camera. Each laser generates two laser pulses within a short time interval, and a total of eight laser pulses are therefore emitted in each pulse train. Using four separate lasers allows different combustion products to be measured simultaneously.

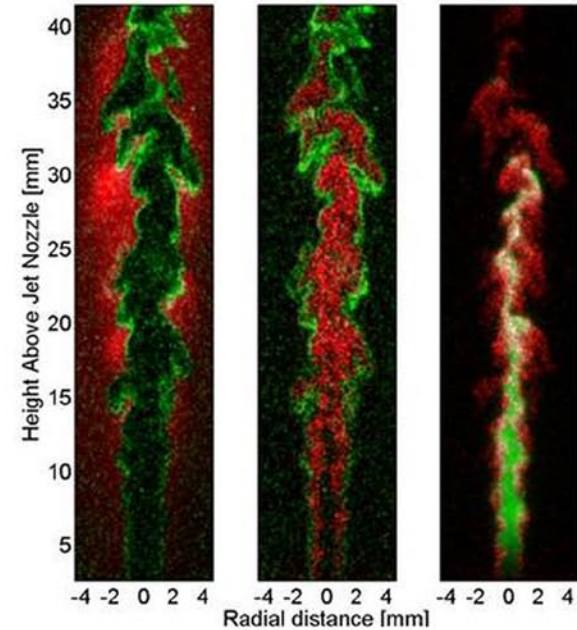

This figure shows LIF measurements of OH (warm product), CH (flame edge), CH₂O (cool zone) and traces of uncombusted fuel (cold zone) in a turbulent jet flame. Each image contains two products. Left: OH (red) and CH (green), Middle: CH₂O (red) and CH (green), Right: CH₂O (red) and fuel (green).

Chemical kinetics

In terms of chemical kinetics, combustion is an incredibly fast series of chemical reactions in which both heat and light are generated.

Within chemical combustion research, chemical models, both theoretical and practical, are being developed that describe combustion in, for example, flames and engines. An important part of this research is the experimental determination of the molecular composition of flames.

Scientists at Lund are extremely skilled in the areas of combustion chemistry and laser diagnostics in flames, providing unique possibilities to study the combustion process. Alexander Konnov from St. Petersburg is responsible for this field of combustion research.



The high-pressure combustion test rig

The high-pressure combustion test rig at the Division of Combustion Physics gives scientists in Lund the possibility to study combustion at high pressures and flows that are similar to those found in gas turbines and aircraft engines. The combination of this test rig and advanced optical/laser-based techniques is unique, and benefits both industry and society as a whole. The measurements made with this equipment provide insight into the complicated processes taking place in different kinds of combustion.

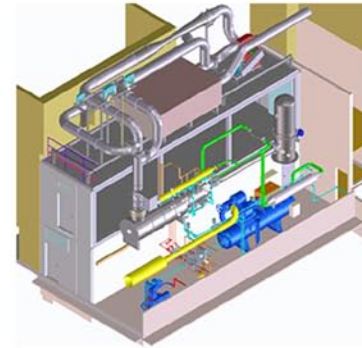

The high-pressure combustion test rig.

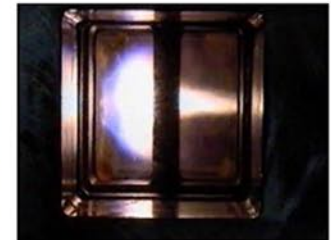

Photograph of a pilot flame in one of the burners tested in the high-pressure combustion rig.

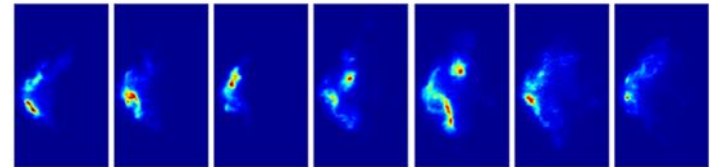

Time series of images of fuel (fuel LIF) from one of the many runs performed using the high-pressure combustion test rig.

The need for more research

Fossil fuels must soon be replaced, and combustion must be made more efficient and environmentally friendly. Renewable fuels must be developed, and diminishing global resources require more energy-efficient equipment. The consequences of acidification and the greenhouse effect have led to political decisions that place higher demands on society. Although the use of fossil fuels is decreasing, our use of biofuels is increasing. This brings with it new challenges. A more sustainable society requires a deeper understanding of combustion and better knowledge concerning the problems involved in the transformation to alternative sources of energy.



Absorption measurements in a planar sooty flame in a McKenna burner.

Combustion physics today – from ecology ...



LUMBO – the Lund University Mobile Biosphere Observatory – is used to study the fauna in the atmosphere, and is one of the new areas of research at the Division of Combustion Physics.

Although much of the research in combustion physics is centred around combustion, the division is also working in a number of other areas where basic knowledge in laser diagnostics, physics and chemistry is important.

A number of methods have been applied for several years to non-reactive gas flows, including the detection of hydrogen peroxide in the sterilization process at Tetra Pak, and optical remote sensing (Lidar) in atmospheric and ecological applications.

... catalysis and plasmas

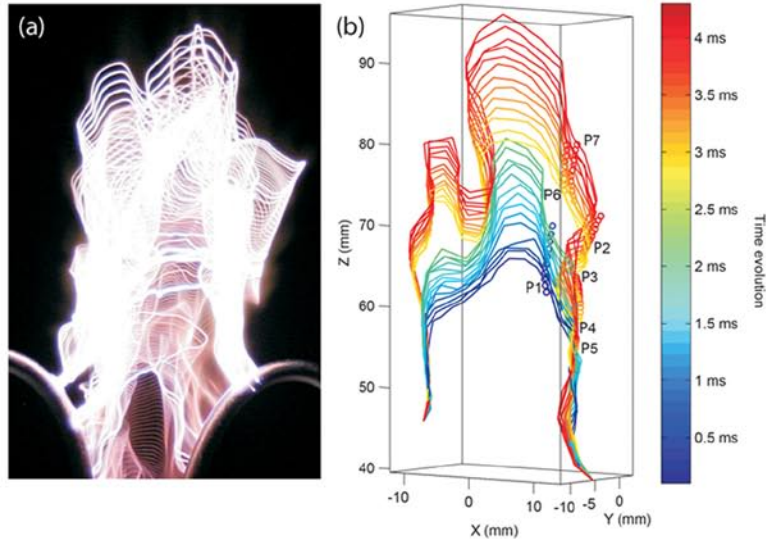

(a) Photograph of a sliding discharge plasma. Like our own eyes, a normal camera cannot discern the discharge as it moves rapidly in the air flow.

(b) Using two high-speed cameras and mathematical image analysis it is possible to obtain images of the discharge at any instant, providing three-dimensional velocity information. The gas flow in this case was tagged with particles to enable the velocity of the surrounding gas to be measured (P1-P7).

The considerable efforts made in laser diagnostics in combustion have made it possible to branch out into completely new areas.

Examples of these are plasmas, gasification, catalysis and nanometer technology. Within catalysis, for example, the gas around an active catalyst can be studied in real time, providing information not previously obtainable.

In plasmas, molecules can be created in special states and their chemical properties can be studied using laser and optical diagnostics.



Foreign submarine

A serious political conflict between Sweden and the Soviet Union, in which a Lund physicist played an active role.

Foreign submarine in Swedish archipelago

On the evening of 28 October 1981 the front pages of the newspapers were filled with a surprising piece of news. A Soviet submarine on a secret mission had run aground on a rock in Blekinge archipelago. It was well inside a restricted military area and not far from Karlskrona naval base.

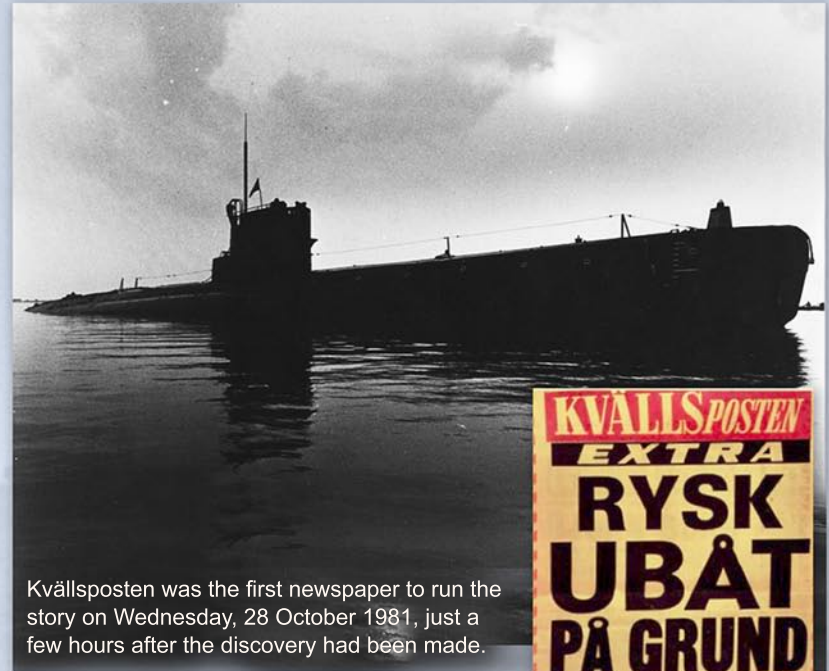

Kvällsposten was the first newspaper to run the story on Wednesday, 28 October 1981, just a few hours after the discovery had been made.

KVÄLLSPOSTEN
EXTRA
RYSK
UBÅT
PÅ GRUND
I KARLS-
KRONA
SKÄRGÅRD!



Heightened state of alert

Swedish military units from the navy and coastal rangers, among others, were assembled in the area over the following days.

A large area was cordoned off. Helicopters and fighter aircraft patrolled the airspace and Swedish submarines were stationed underwater along the limit of territorial waters.

The naval ship Thule was stationed as a barrier in the strait out towards open water.

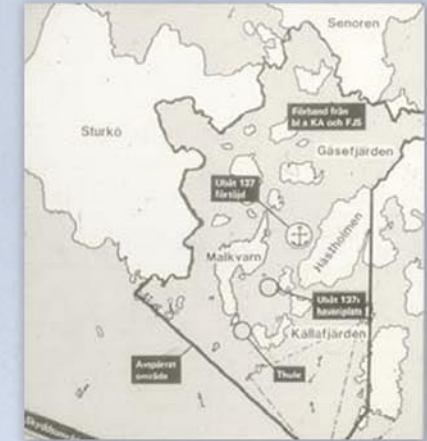

In all probability armed

In an extra edition of the television news programme *Aktuellt*, a week after the grounding, Prime Minister Torbjörn Fälldin revealed that the submarine:

"... in all probability ..."

was armed with nuclear weapons.

Political activity in Sweden and internationally was great. This was world news!



Dagens Nyheter, 6 November 1981. The day after the Prime Minister's revelation that there were nuclear weapons on board the submarine U137.

On a secret mission

In order to investigate whether the submarine was armed with nuclear weapons, measurements of the ionising radiation needed to be carried out. Reader Ragnar Hellborg from the Department of Physics in Lund was one of those who performed the measurements on behalf of the Swedish Defence Research Agency:

It was around dinnertime on All Hallows' Eve when the phone rang. I was with a doctoral student in the control room of our accelerator. We were planning to carry out accelerator experiments over the three days and nights of the weekend.

At the other end of the line was a colleague from the Swedish Defence Research Agency. His brief question was:

- We need help to measure neutrons, do you have access to a suitable monitor?

My answer was also brief:

- I'll fix a neutron monitor and go home, pack a small bag and await further instructions by telephone.

Once home with the monitor packed in a bag, the police rang:

- We have orders to fetch you and drive you to the county boundary, where the Kristianstad force will take over.

The national police commissioner, who had been given the task of arranging transport by the Supreme Commander of the Swedish Armed Forces, was cunning and divided the journey between four police cars. No individual police officer would easily be able to work out the purpose of my journey.

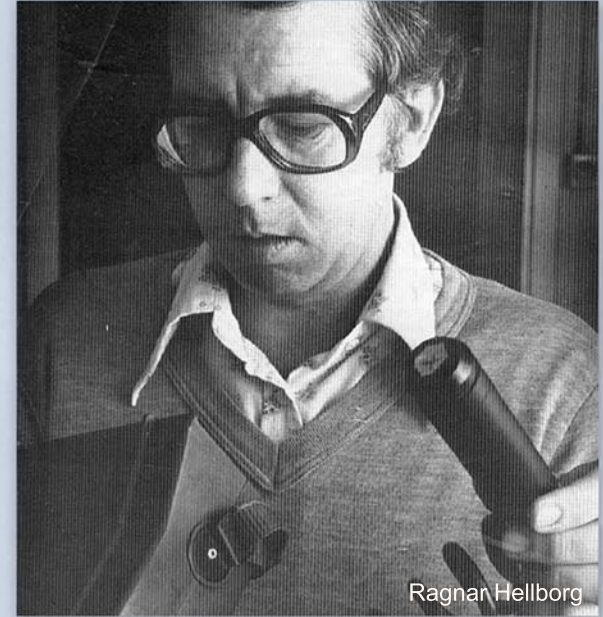

Gamma radiation

The first, simple measurements were taken with handheld gamma and neutron instruments during the night of All Hallows' Eve, Friday 30 October.

The measurements indicated gamma radiation from a point a metre or so behind one of the torpedo openings at the bow of the submarine.

The conclusion from these first measurements was that there was a gamma source within a metre or a few metres of the detector in the direction of the submarine.



Gamma detector

In order to determine what type(s) of atomic nuclei were emitting the gamma radiation, much more advanced equipment was needed. This equipment was fetched during the Saturday night from the Department of Physics in Lund and the Defence Research Agency in Stockholm. Among other things, two containers with a total of 50 litres of liquid nitrogen (temperature -196°C) were transported from Lund to be used to cool the very advanced gamma detector.

Mysterious measurements

On Sunday evening the measurement equipment was loaded onto the coastguard vessel Tv103. The equipment was placed below deck, so as not to be visible from above.

The crew on the submarine were under no circumstances to find out that radiation measurements were being taken. The crew of the coastguard vessel were also kept in the dark. They believed that their ship was being used for radio interception. The equipment was set up and trimmed.



Explanatory sketch of the positioning of the detector as close to the submarine as possible. The long horizontal tube pointing towards the submarine contains the sensitive gamma detector.

Below deck

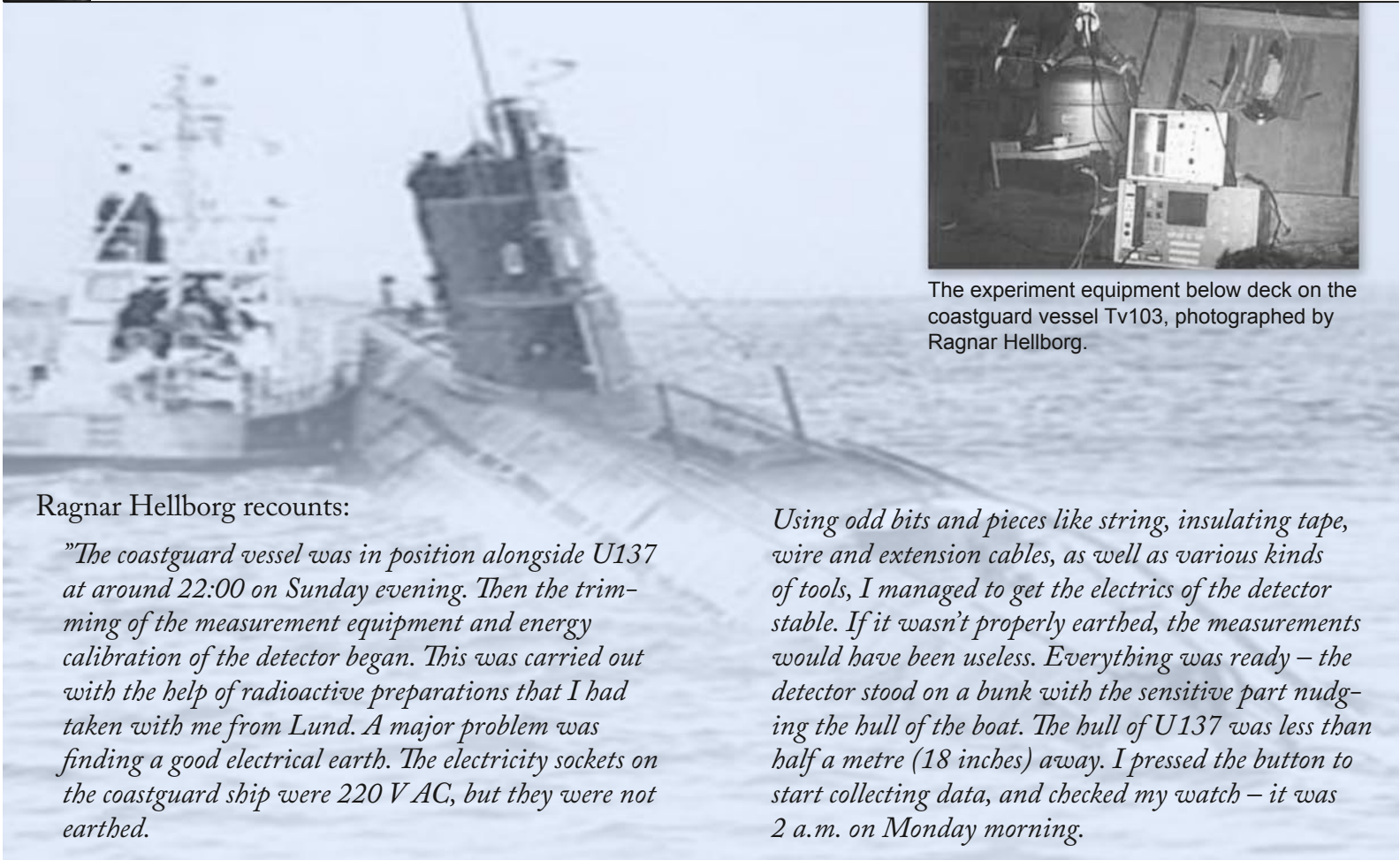

The experiment equipment below deck on the coastguard vessel Tv103, photographed by Ragnar Hellborg.

Ragnar Hellborg recounts:

"The coastguard vessel was in position alongside U137 at around 22:00 on Sunday evening. Then the trimming of the measurement equipment and energy calibration of the detector began. This was carried out with the help of radioactive preparations that I had taken with me from Lund. A major problem was finding a good electrical earth. The electricity sockets on the coastguard ship were 220 V AC, but they were not earthed.

Using odd bits and pieces like string, insulating tape, wire and extension cables, as well as various kinds of tools, I managed to get the electric of the detector stable. If it wasn't properly earthed, the measurements would have been useless. Everything was ready – the detector stood on a bunk with the sensitive part nudging the hull of the boat. The hull of U137 was less than half a metre (18 inches) away. I pressed the button to start collecting data, and checked my watch – it was 2 a.m. on Monday morning.

Finally a result

After only 20–30 minutes, two clear signals could be observed with energy of 1001.0 keV and 766.6 keV. These signals unequivocally identified the radiation as being due to the presence of atomic nucleus ^{238}U .

There was uranium on the submarine!

The measurements continued until the morning in order to gather reliable statistics.

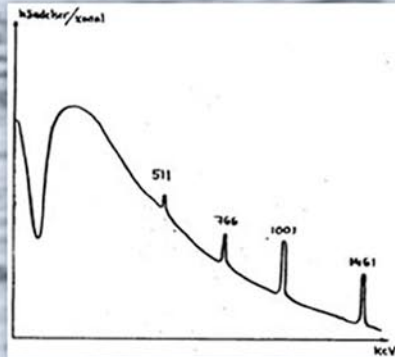

Appearance in principle of the measurement results.

Like a Hiroshima bomb

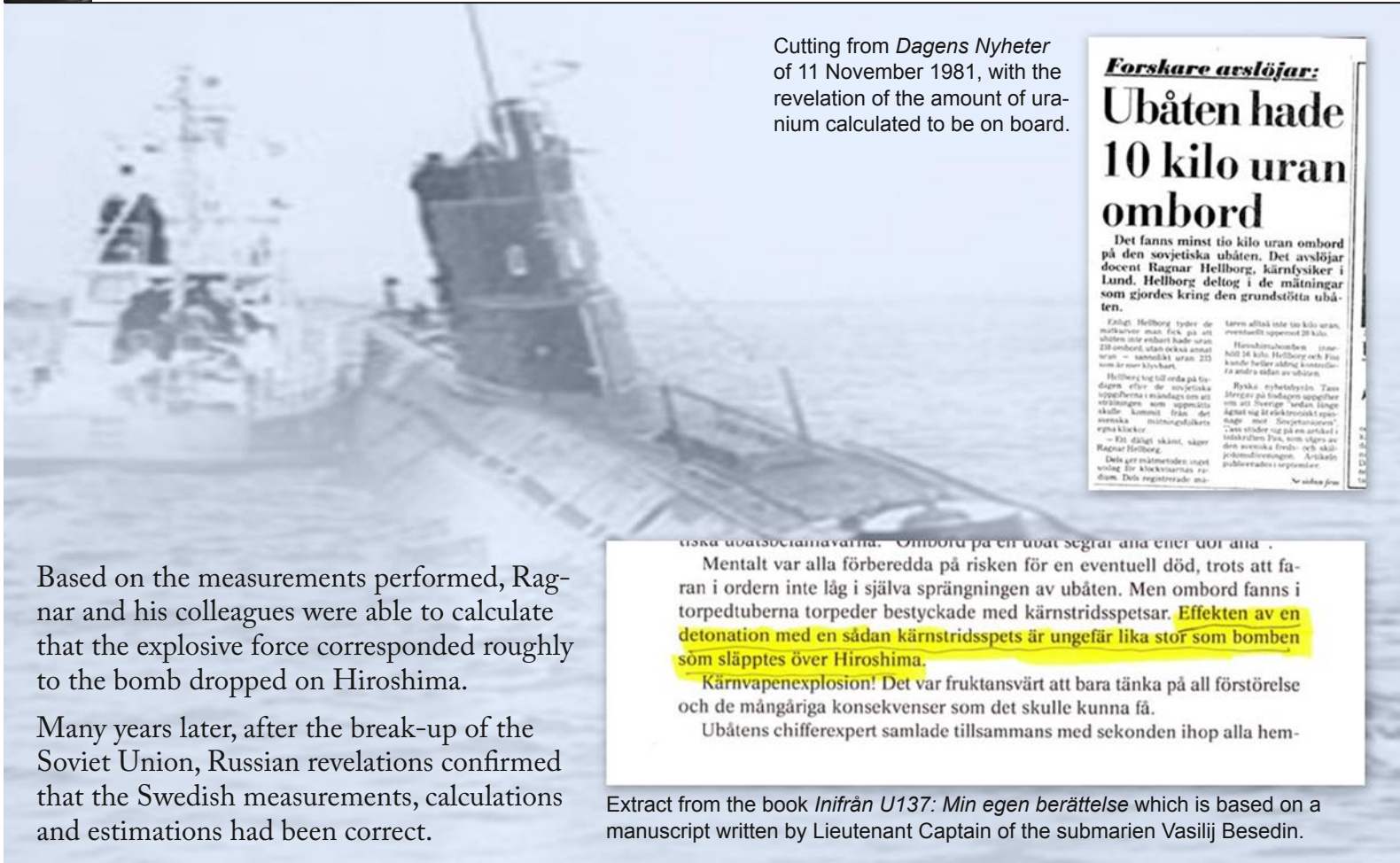

Cutting from *Dagens Nyheter* of 11 November 1981, with the revelation of the amount of uranium calculated to be on board.



Based on the measurements performed, Ragnar and his colleagues were able to calculate that the explosive force corresponded roughly to the bomb dropped on Hiroshima.

Many years later, after the break-up of the Soviet Union, Russian revelations confirmed that the Swedish measurements, calculations and estimations had been correct.

...ska ubåtsbetjäntarna. Ombord på en ubåt seglar alla ener dot all .
Mentalt var alla förberedda på risken för en eventuell död, trots att faran i ordern inte låg i själva sprängningen av ubåten. Men ombord fanns i torpedtuberna torpeder bestyckade med kärnstridsspetsar. **Effekten av en detonation med en sådan kärnstridsspets är ungefär lika stor som bomben som släpptes över Hiroshima.**
Kärnvapenexplosion! Det var fruktansvärt att bara tänka på all förstörelse och de mångåriga konsekvenser som det skulle kunna få.
Ubåtens chifferexpert samlade tillsammans med sekonden ihop alla hem-

Extract from the book *Inifrån U137: Min egen berättelse* which is based on a manuscript written by Lieutenant Captain of the submarien Vasilij Besedin.

Revelations



Cutting from *Sydsvenskan*, 23 January 1992. The article was published after a TV3 interview with the captain of the submarine.

Another revelation was made in an interview with the captain of the submarine Anatoly Gushchin shortly after the fall of the Soviet Union.

Gushchin said that he had received orders from Moscow to blow up the submarine if the Swedish military attempted to storm it.

What happened next?

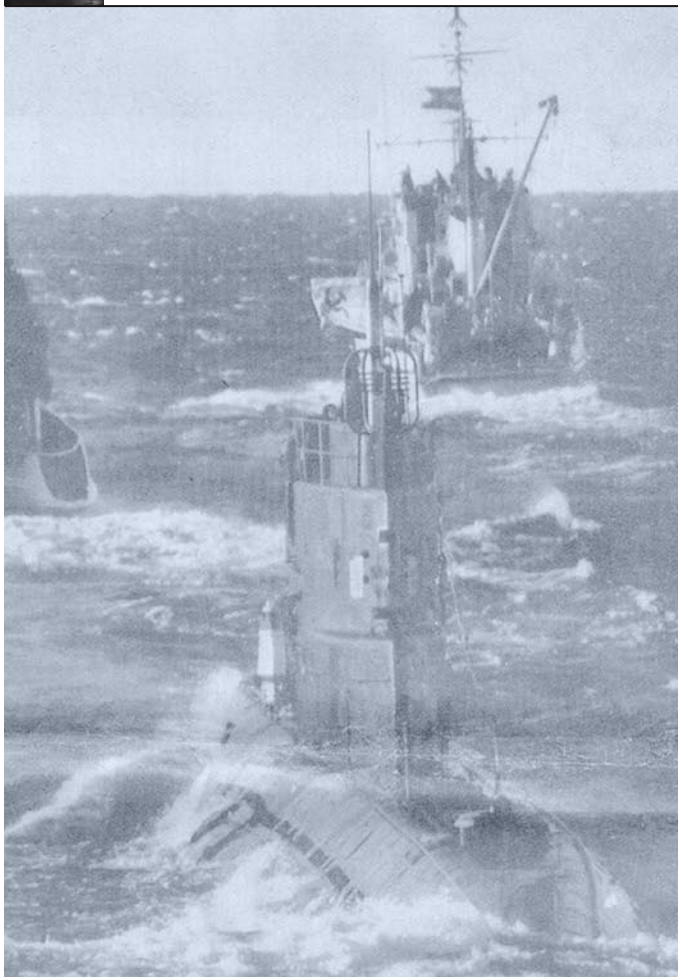

A fierce storm forced the measurements to stop on Monday morning. The storm was so fierce that the submarine had to be pulled off the rock so as not to break up against the cliffs. Soviet units were not permitted to pass into Swedish territorial waters and a Swedish tug therefore pulled the submarine off the rock. A few days later, when the interrogation of Anatoly Gushchin was complete, the submarine was handed over to Soviet forces, which were waiting just outside Swedish waters.

Why the Soviet submarine ended up in the archipelago has never been resolved, but the discovery of uranium resulted in one of the sharpest protest notes that Sweden has ever issued.



The development of teaching

When were students first taught experimental techniques in the lab?

When was it decided that a doctoral thesis had to be written independently by the student?

When did a woman get a PhD in Physics in Lund for the first time?

Standard measures

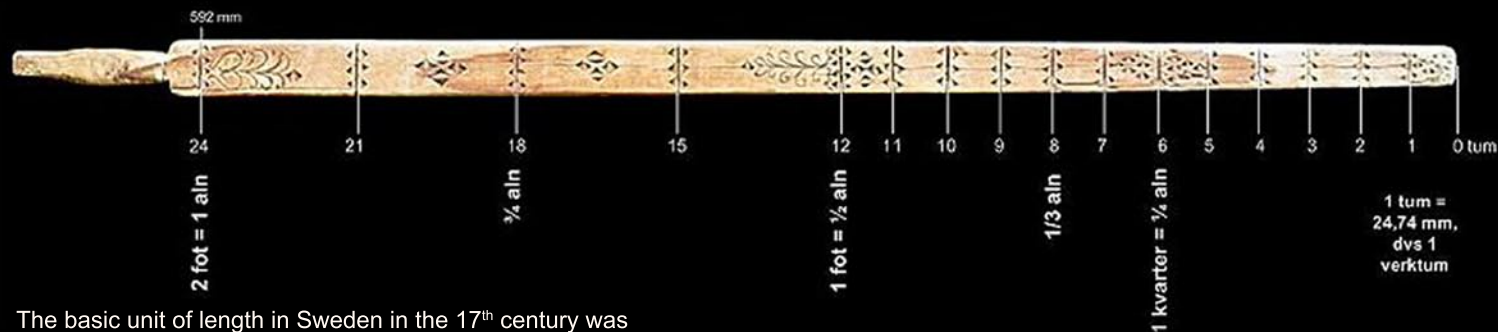

The basic unit of length in Sweden in the 17th century was the aln, which is about 60 cm (or 2 feet). There were 3 alns to a famn (an 'armful'), and 5 alns made up a stång (staff or pole). The length of the aln later became standardized and is equivalent to 0.593784 metres.

In 1666, when Lund University was founded, a kind of yardstick and a set of volumetric measuring cans developed by Georg Stiernhielm, who was the director of Antikvitetskollegium (the Council of Antiquities) were the standards of the day. These basic measures had been defined in the Swedish system of measurements in the previous year, 1665. These have been preserved and are kept at the Museum Kultu- ren in Lund.



The standard unit of volume was a kanna (can), which was equivalent to 2.617 litres, and was used for both liquids and dry goods. A tunna (barrel) of dry goods contained 56 kannas, or 146.55 litres.

Teaching professors

Nineteen professorships were established at the new university in Lund, two of which were in mathematics. Physics was included in the field of mathematics at that time.

One of these professorships, which was more physically oriented, was awarded to Anders Spole, and the other, which was more applied, to Martin Nordeman. Both had been educated in Uppsala.

Spole taught trigonometry, astronomy, navigation, geography, chronology and optics, while Nordeman taught mechanics (levers, winches, the screw and the wedge), thermodynamics and surveying.



Anders Spole (1630-1699)

Spole was an enthusiastic man Spole had a private observatory with a long telescope and a large quadrant built in St. Petri Kyrkogata. The observatory was burnt down in 1676 during the Battle of Lund, and all his equipment was destroyed.

Handwritten compendia

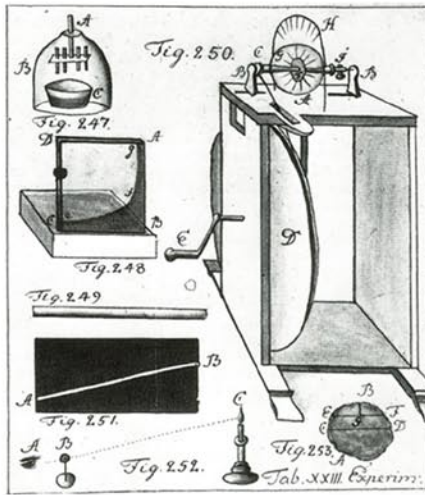

An instrument from the Triewald Collection, used for conducting experiments with electricity.

An example of an elegant compendium by N Schenmark, entitled *Collegium Curiosum & Experimentale*, from 1743, in which the author documents Daniel Menlös' lectures.

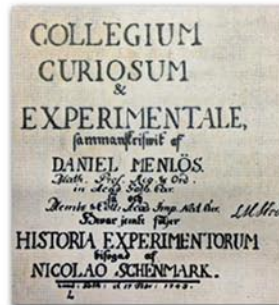

Teaching at the beginning of the 18th century consisted of lectures and demonstrations, and was characterized by the heated dispute on atomism between the followers of Aristotle and Descartes. The students compiled their own compendia, and textbooks were rare. It could take several years to complete a compendium.

Mårten Triewald purchased a number of physical instruments in England and Holland (the Triewald Collection), which he demonstrated in Stockholm in 1728-29. Daniel Menlös managed to take over the collection, and used it to secure a professorship in mathematics in Lund, which he took up in 1732.

The first assistant

Professor Menlös was the first to teach Newtonian mechanics, and it was hoped that the Triewald Collection would afford Lund University the same status as the renowned universities of England and Holland.

The collection required not only somewhere to be kept, but care and maintenance, and the position of Custos Machinarum (the Custodian of the Machines) was established in 1735. With this, the Department of Physics had obtained its first assistant.

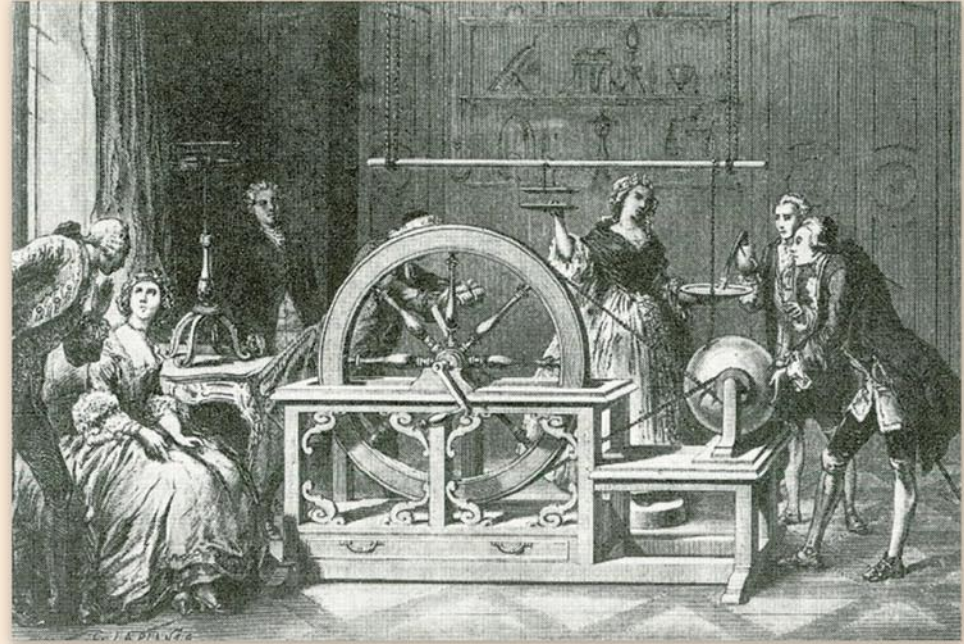

New instruments were added to the collection, such as this electricity machine in 1754.

The development of doctoral studies

Teaching and examinations remained unchanged during the 18th century. There was only one kind of degree, the kandidat (Bachelor's) degree, after which students continued their studies pro gradu, to obtain a magister or Master's degree.

Dissertations or theses were seldom written by the student himself, but often consisted of material already published, or written by the student's supervisor. The most important thing was to show that you could present your arguments in public, in Latin. It was not until 1852 that doctoral students were required to write their theses themselves.

During the 18th century, there were about 200 students studying at any one time at Lund University, several of whom were under 15 years of age.



This drawing shows a doctoral examination (Examen Rigorosum) in Lund, which was held on 19 May 1791. The examiner was Pehr Tegman, Professor of Mathematics. (The drawing is kept at Kulturen in Lund.)

Course compendia

A handwritten compendium in physics, based on the lectures of Pehr Tegman from 1794, has been preserved. In its margins are notes on experiments, written by Esaias Tegnér, a famous Swedish writer and poet. He came to Lund in 1799 and obtained his Master's degree in May 1802. He had himself copied an older compendium. From this compendium it can be seen that the course in physics included Newton's laws of motion, the history and benefits of physics, the divisibility of bodies, momentum, death force and living force, Compressibilitas, Elasticitas, Fragilitas, Centrum gravitatis, Machina simplex and electricity among others.



Esaias Tegnér 1782 - 1846

Tegnér's poetry bears witness to his education in physics. This poem was submitted to the Swedish Academy on the 30 September 1801, just before his Bachelor's examination:

*Through life's torments and consolations
Go, study the hidden essence of every thing,
Let the shores of the sea of time
Bind the flight of the birds, map the course of the stars,
Cleave the beam of light, weigh the air ...*

The instrument collection grows



The Daguerre camera purchased by AW Ekelund in Paris in 1840.

A professorship in physics was established in 1833, to which AW Ekelund was appointed. Physics thus became a subject of its own, independent of mathematics. Ekelund set about renewing the collection of instruments, and in 1840 he purchased no less than 213 acoustic, electrostatic and optical instruments in Paris, including a Daguerre camera. This camera, a Guericke vacuum pump and Stiernhielm's measuring cans are regarded as being among the most valued items owned by the Department.

Laboratory experiments

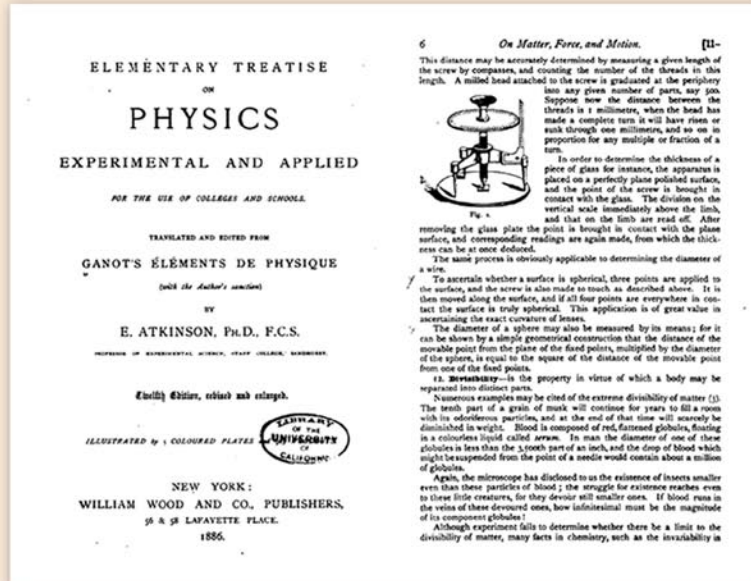

The textbook for the introductory course was Ganot's well-known book, *Traité élémentaire de Physique*. Students who had taken the course could become physics teachers, and the course was also taken by medical students.

KAV Holmgren arrived in Lund in 1861. He had attended Uppsala University, and understood the importance of laboratory work in teaching. Students were already able to work in laboratories in Uppsala, and Holmgren made it possible for students who were especially interested in physics to have access to laboratory experiments in Lund.

During his work in the laboratory in the old Department of Physics at the turn of the century, Enoch Thulin determined the specific heat of metals, the expansion coefficient of air, the linear expansion coefficient of metals and measured the angles between the planes in crystals.

Three pioneering women



Anna-Clara Romanus-Alfvén (1874-1947) was one of the very first women to study at the Department of Physics, when she took the introductory course in physics in 1897. After obtaining a licentiate degree in medicine in Lund in 1906, she practiced as a doctor in Norrköping, among other places. In 1908, Anna-Clara became the mother of a future Nobel Laureate in Physics, Hannes Alfvén, and later the grandmother of a professor in accelerator physics, Mikael Eriksson.



Louise Petrén-Overton (1880-1977) was one of the first women to conduct practical experiments at the Department, in 1900. In 1912 she became the first Swedish woman to obtain a doctoral degree in mathematics. At that time, there were 600 students at the university, 10 of which were women, and two of these were studying the natural sciences.



The first woman to obtain a doctorate in physics at the Department of Physics was Gerd Risberg, in 1968.

The need for physicists increases

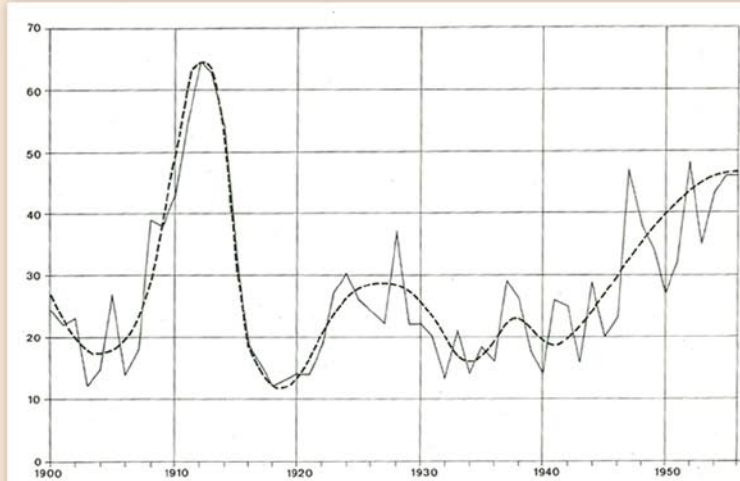

Diagram of the variations in the number of students in physics for a Magister's Degree 1900 - 1954. Solid lines gives present annual changes.

The dashed curve gives the tendency of development.

In 1905, laboratory exercises were introduced in secondary schools, and this affected teaching at universities. It was also decided that all middle schools should have the same national curriculum. This led to a sharp increase in the number of students applying to study to become physics teachers. During a few years around 1910, the number of physics students rose from about 15 to over 60 per year. As a result of this, Manne Siegbahn was able to collect a group of postgraduate students who were employed as supervisors for these students, and research in physics flourished.

Public demonstrations in physics

Students were trained to carry out physical demonstrations in public; one course being led from 1949 to 1967 by Osvald Lundquist, the last of Manne Siegbahn's postgraduate students. His experiments could be carried out in secondary schools using the equipment available in the schools, and are described in two compendia entitled *Experimental Physics*.

The equipment was to be easy to understand, and the student was to demonstrate a physical phenomenon, such as wave motion on the surface of a liquid, the heat generated by an electric current, the crystal diode and the transistor, and make measurements.

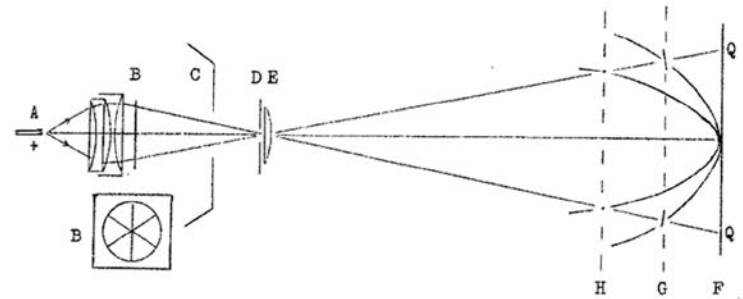

A page from one of Osvald Lundquist's popular compendia on experimental physics.

The second half of the 20th century

Teaching in physics continued to develop. A balcony was constructed in the Rydberg lecture hall at the Department of Physics to allow more advanced demonstrations. Teaching in the laboratories included classic as well as modern experiments, e.g. the determination of the gravitational constant, and the ratio of Planck's constant to the electronic charge, h/e , from the photoelectric effect. The latter was demonstrated by John Koch, aided by Nils Ryde and Lennart Minnhagen, who later became professors at the department.

During the 1950s, more advanced courses in atomic spectroscopy, electronics and nuclear physics were introduced. These included week-long laboratory practicals, and became very popular.

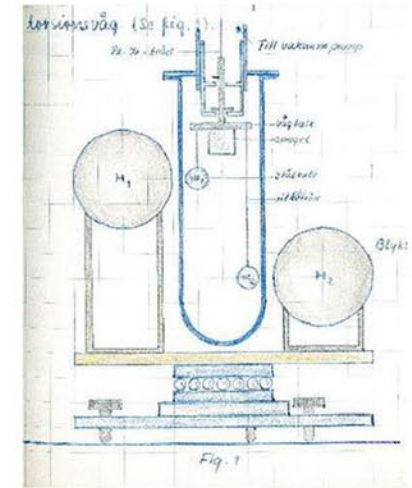

Determination of the gravitational constant.

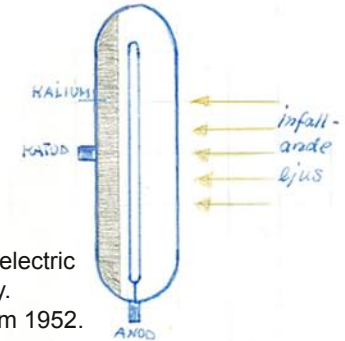

Determination of h/e from the photoelectric effect, according to Einstein's theory.
From Hans Ryde's lab write-ups from 1952.

Teacher training

During the 1960s, the one-year course in physics included not only classical subjects, but also atomic physics, nuclear physics and the theory of relativity.

The number of physics students fell during the 1970s, due partly to an earlier dip in the birth rate, and partly to the anti-nuclear power movement. It was thus decided that it was time to modernise teaching in physics and to offer courses covering a broader field.

A new teacher education programme was introduced with the motto, *Start your teacher training with physics*. The mid-1990s saw increased numbers of students, some from other countries, and lectures started to be given in English.

Several lecturers at the Department of Physics wrote their own textbooks.

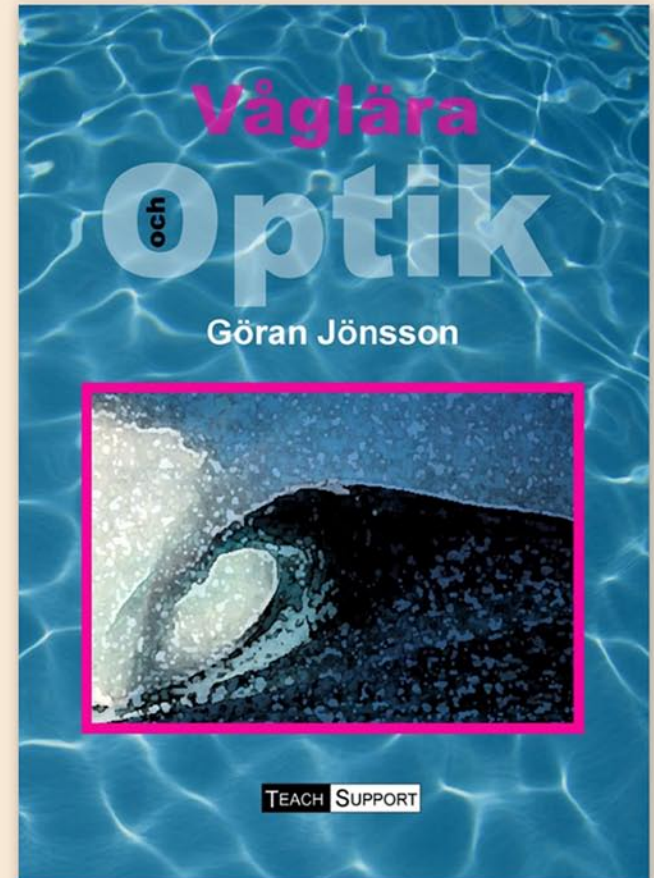

Teaching at the Faculty of Science

The *Experimental Seminars course* at the Faculty of Science has attracted considerable attention, both in Sweden and other countries. Visiting lecturers from many different countries have been involved. Students can choose which experiment they want to perform, and the presentation of their results at a seminar provides good practice in communication skills. The course is carried out in close collaboration with research divisions within the faculty. The example given below is from the Division for Synchrotron Radiation Research.

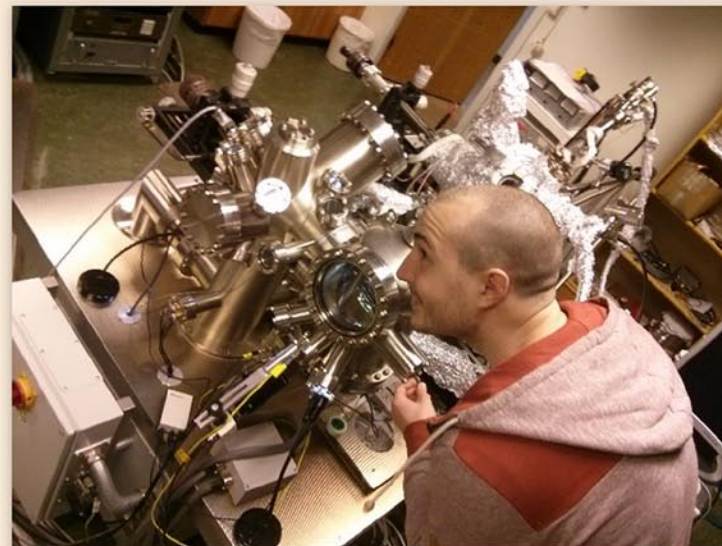

Johan Knutsson, a PhD student and supervisor at the Division for Synchrotron Radiation Research, setting up an electron microscope.

Science vs. engineering



The ESS Project.

Areas within the Faculty of Science.

- Physics
- Meteorology
- Astrophysics
- Chemical physics
- Theoretical physics
- Hospital physicist (5 years)
- Specialist Teacher Training (4½-5 years)

Compulsory courses within the Faculty of Engineering.

- Quantum physical concepts
- Statistical thermodynamics and applications
- Atomic and nuclear physics and applications
- Solid state physics
- Vector analysis
- Wave theory and optics

One of the greatest advantages of teaching physics in two different faculties in a single large department is that they have positive effects on each other. When teaching by the Science Faculty was extended to include students destined for other professions than teaching in the increasingly technological world, the courses taught by the two faculties came closer together.

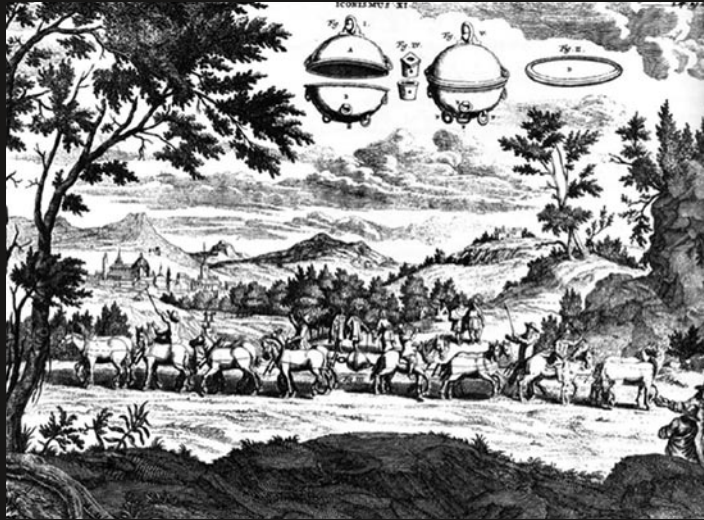

External activities

How physicists from Lund made science understandable for everyone.

Vacuum

There is a tradition at the Department of Physics in Lund of explaining physical principles to the general public. This was the case throughout the 20th century, and is still the case today. This tradition is based on the Triewald collection of instruments that Daniel Menlös brought with him to Lund in 1726.

One of the items of greatest value is the original pump used by Otto von Guericke to demonstrate the principle of vacuum to Frederick Wilhelm I of Brandenburg in 1683, with the aid of the Magdeburg hemispheres.

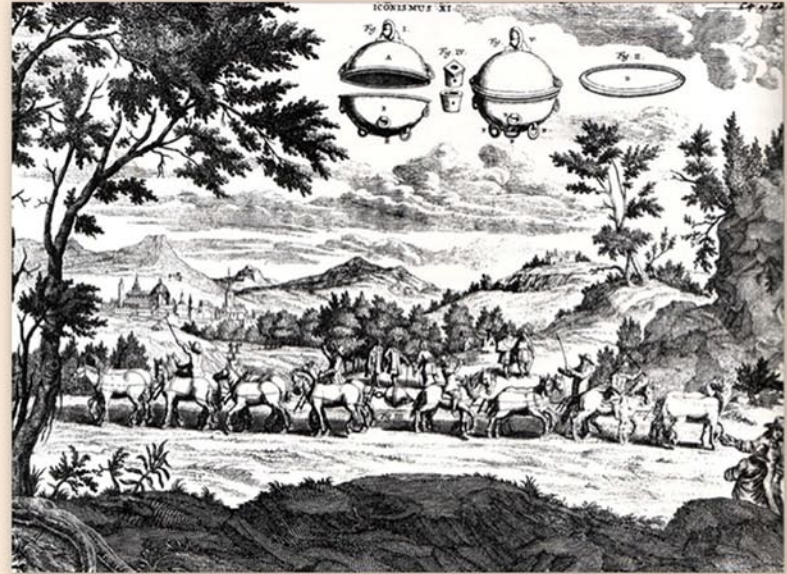



Ask Lund

Educating the public took off in the 1960s when television made its breakthrough in Sweden. In 1962 a series of TV programmes called *Ask Lund* started, in which six learned professors from Lund University answered viewers' questions. The programme proved very popular and spread knowledge on science and research throughout the country.

One of the experts was Sten von Friesen from the Department of Physics. His ingenious and sophisticated explanations made good viewing. Many Swedes still fondly remember his explanation of how the Romans managed to carry out long division with their unwieldy system of numbers.



David Ingvar and Sten von Friesen in *Ask Lund*.

Bodil Jönsson

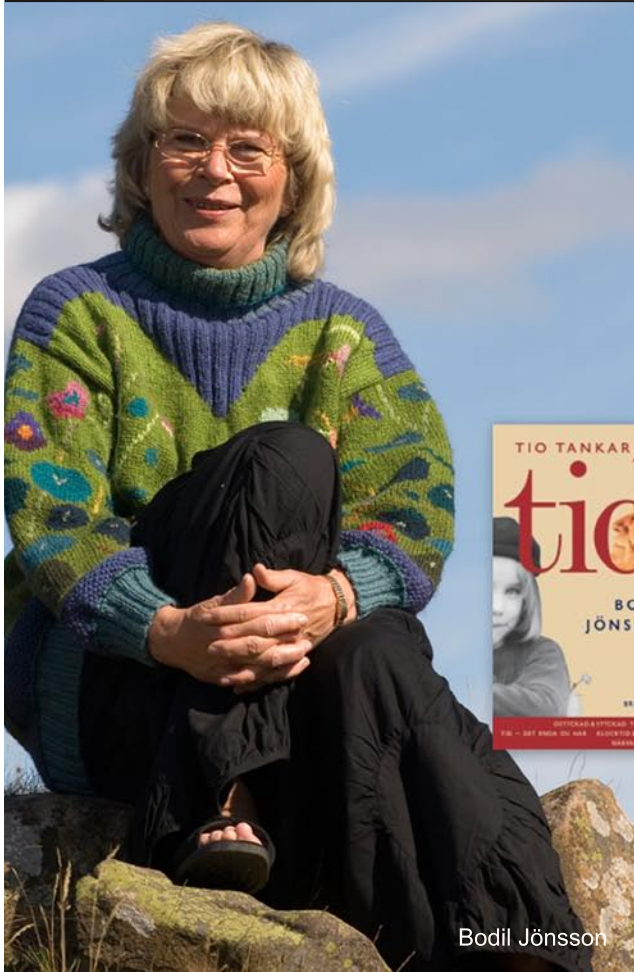

Bodil Jönsson

When the TV series *Ask Lund* was revived in the 1990s, Bodil Jönsson was there to answer questions on physics. She had by then left the Department of Physics to be director of CERTEC, the Division for Rehabilitation Technology at LTH.

Bodil soon became very popular with the public due to her astute and objective way of explaining physics, making it both understandable and interesting to the layman.

One of her books, *Ten Thoughts on Time*, has been published in over 20 countries.



Hans Uno Bengtsson



The physicist and performer, Hans Uno Bengtsson, walking on hot coals.

Hans Uno Bengtsson was a bit more dramatic in his approach, being rather a showman. His interests were broad, from physics to food, and he was a much sought-after public speaker. He often toured the country giving lectures on various subjects.

He was able to explain quantum mechanics or the Higgs particle by working out how many times one would have to kiss a girl for her lipstick to wear off, or by using the *Adventures of Baron Munchausen*.

Bengt E Y Svensson

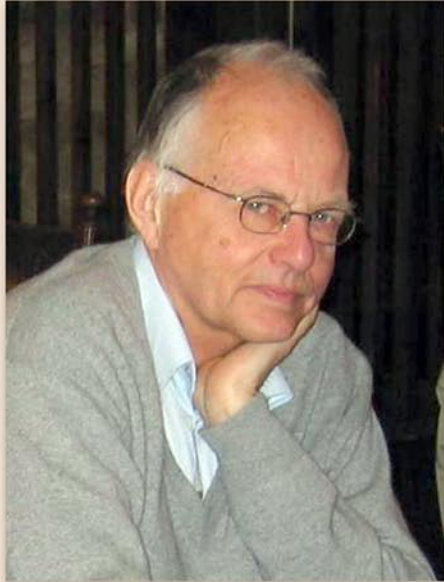

Bengt E Y Svensson,
Professor Emeritus in Theoretical Physics,
and former dean and pro-vice-chancellor.

The name Bengt E Y Svensson crops up often in connection with popular science. He is able to explain physical phenomena and critically scrutinize scientific ventures. He often takes part in *the Philosophical Circle* and *the Science and Technology Circle* at Lund University, and writes articles in the local, scientific and national press. He has also taken part in many radio and television programmes as well as reviewed a large number of books.



The importance of a good teacher

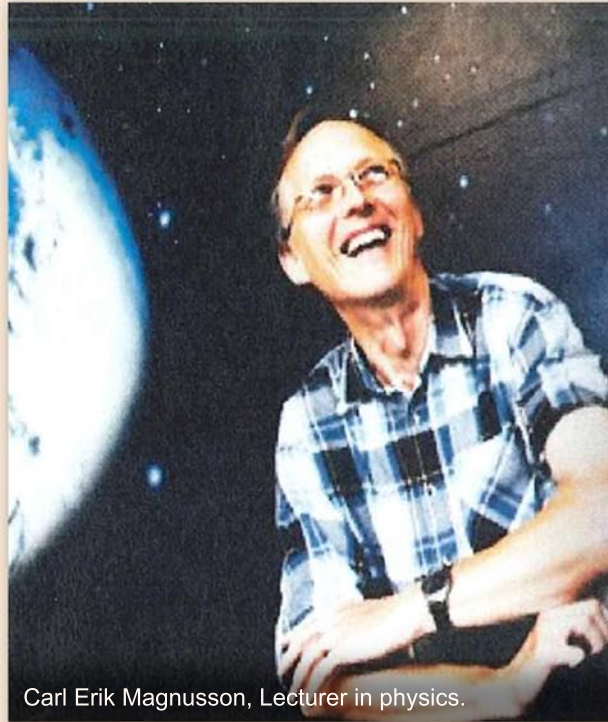

Carl Erik Magnusson, Lecturer in physics.

The importance of teaching in schools and adult education programmes cannot be overestimated. Many people bear witness to the fact that a particularly knowledgeable or enthusiastic teacher changed their lives. It may have affected their choice of career or simply the way they think. Critical thinking is decisive in public debate, especially regarding the environment and risk management. Carl Erik Magnusson is one such teacher; his outlook on life and his empathy have inspired students and stimulated public debate.

The nuclear power debate



Physicists are like the members of any other group in society; they are individuals with their own opinions. In 1976, the debate on nuclear power in Sweden was in full swing. A protest march took place on 7th of August which passed along Sölvegatan, and the protesters saw the following message taped on to the windows on two floors of the Department of Physics:

PHYSICISTS ARE FOR NUCLEAR POWER

The marchers halted, shaming the scientists with a chant of: *Fy, Fy, Fysiker!*



The Grande Dame of the Department

Cecilia Jarlskog is an excellent representative of the Department of Physics, both nationally and internationally. She has been a member of the Nobel Committee for Physics and is a member of both the Swedish and Norwegian Academies of Science.

In the international arena, Cecilia served as an advisor to the Director General for CERN's member states for several years. She is a member of Academia Europa as well as an honorary professor at three Chinese universities.

Cecilia Jarlskog is a highly respected speaker in great demand. She is also passionate about the importance of research.

How will we be able to find tomorrow's Einstein, the way things are today? I'm extremely worried about the situation of young scientists. They're under so much pressure – they have to write loads of applications and go to countless meetings. Give them the opportunity to get on with their research undisturbed!



Cecilia Jarlskog, Professor Emeritus in Particle Physics.

Kids and researchers

A project that was very successful in Skåne at the beginning of the 1980s was *Children Meeting Scientists*, initiated by Barbro Forkman. The aim of the project was to provide children with the opportunity to meet and get to know scientists; to go to lectures, to ask questions, and have them answered by researchers. Finding out about experiments and investigations in progress at university departments and taking part in simple experiments was also part of the project.

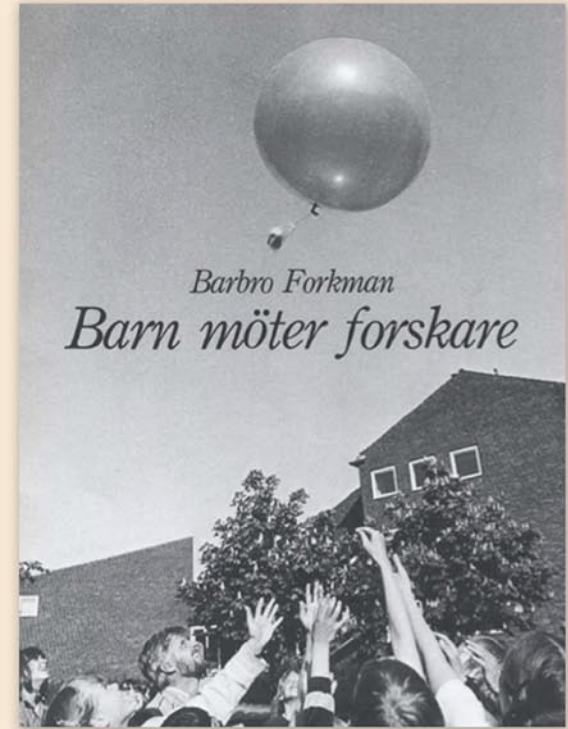



The scandal in the Hallandsås tunnel

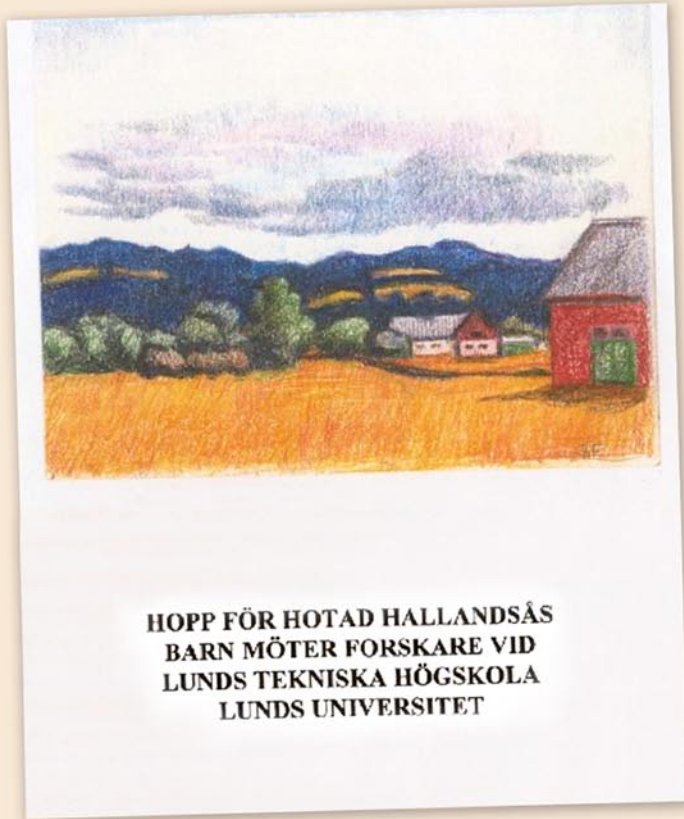

In 1992, the Swedish State Railway (SJ) started the construction of a tunnel through the Hallandsås Ridge. It was planned to open in 1995 but many problems were encountered. The most serious was the contamination of the environment by a sealing compound containing acrylamide. Fish started dying and workers became ill.

Thus a large number of school children from the area were brought to Lund by coach, and the problems were explained to them in an objective and understandable way. The children were able to ask experts, listen to a talk on the geology of the ridge, and carry out experiments.

National resource centre for physics



The ability of the teacher is a decisive factor in the classroom. The National Resource Centre for Physics provides school teachers with better tools for their occupation. This resource centre for physics teachers was started in Lund in 1995, as a result of the success of the programme *Children Meeting Scientists*.

The director of the centre was Gunnar Ohlén, who arranged a number of courses for teachers and established a web-based forum where children can ask questions related to physics. He was succeeded in 2009 by Ann-Marie Pendrill, professor in theoretical atomic physics. In 2014, she was appointed professor in scientific communication and physics teaching.

Physics in action on the big dipper. Amongst many other things, Ann-Marie Pendrill developed playgrounds and amusement parks at science centres.



The science and technology circle

The Science and Technology Circle has existed at Lund University since 1995, and regular lectures, open to all, are arranged in a variety of topics. Since then, Popular science lectures have been arranged with varying regularity in Lund, Växjö and Halmstad. Theoretical physicists from Lund, Gösta Gustafson, Hans Uno Bengtsson, Gunnar Ohlén and Bengt E Y Svensson have been regular speakers at the Circle.

Det internationella astronomiåret

– Fyrahundra år sedan en spionkikare förändrade världen

Öch ändock rör hon sig – Galileo som naturvetenskapens portalfigur

Bengt E Y Svensson, Teoretisk högenergifysik
HA 3/3 • LD 4/3 • VX 5/3

Astronomi och musik – "Jorden hallå, hallå, hallå"

Gunnar Jansson, Sonorum
HA 10/3 • LD 11/3 • VX 12/3

Little bang – Om att studera den stora smällen i laboratoriet

Leif Lönnblad, Teoretisk högenergifysik
HA 17/3 • LD 18/3 • VX 19/3

Färgsprakande galaxer – en guidad tur ut i universum

Sofia Feltzing, Astronomi
HA 31/3 • LD 1/4 • VX 2/4

Det våldsamma universum – Om supernovor, svarta hål och galaxkollisioner

Daniel Malmberg/Daniel Adén, Astronomi
HA 14/4 • LD 15/4 • VX 16/4

Astrobiologi – Finns det liv därute?

Dainis Dravins, Astronomi
HA 21/4 • LD 22/4 • VX 23/4

Större teleskop - större astronomi – Om teleskop för synligt ljus, galaxer, stjärnor och planetsystem

Arne Ardeberg, Astronomi
HA 5/5 • LD 6/5 • VX 7/5



FRI emnet!

Sa det "Bang" när universum föddes? – Om kosmologi och universums struktur

Cecilia Jarlskog, Matematisk fysik
HA 12/5 • LD 13/5 • VX 14/5

En solforskares bidrag i klimatdebatten

Henrik Lundstedt, Institutet för rymdfysik
VX 18/5 • HA 19/5 • LD 20/5
(OBS! Omkastade veckodagar!)

Är människan verkligen skapelsens krona? Om astrobiologins vetenskapshistoria

Gustav Holmberg, Forskningspolitiska institutet
HA 26/5 • LD 27/5 • VX 28/5

Spring programme for 2009.

The discovery club and the research club



The Discovery Club and the Research Club are intended for 6- to 7-year-olds and 9- to 10-year-olds, respectively. The aim of both is to show that physics can be both interesting and exciting. The groups meet 10 times per term and are led by students from the department. These activities were initiated in 1997 by Per Olof Zetterberg, assisted by Johan Zetterberg and Benny Asp.



The physics and laser show

In 1996, Per Olof Zetterberg, together with a number of students, gave a show for pupils aged 13-15. At the end of the show, they applauded wildly and shouted *One more time!* Since then, the show has been repeated many times, and the physics and laser show is today a well-known concept.

A fantastic show that gives an idea of what fun physics can be.

See fantastic experiments with fire, light, sound, pressure and vacuum.

Be fascinated by the wonderful laser show with incredible special effects.

Clips from the press

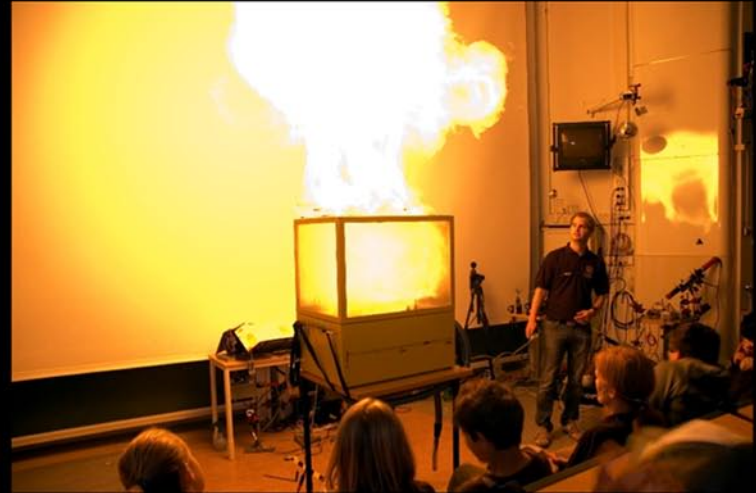

Father and son, Per Olof and Johan Zetterberg, were the physicists behind the popular physics and laser show.

The show has been a success!



Enthusiastic audience in a packed auditorium in Oslo.

The real breakthrough for the Lund physics and laser show came in 2000, when it was given for the first time at the International Science Festival in Gothenburg, where it was a great success. Since then, it has been a popular event attracting the biggest audience at the festival. The show is given several times a year at the Department of Physics in Lund, attracting many visitors. It has also achieved international acclaim, and has been presented in China and several European countries.



Science meets culture



The city of Lund has arranged an annual event called *Culture Night* since 1985. One of the events on this evening in September is the physics and laser show, which attracts large crowds to the department.

In order to provide other interesting activities, an Open Air Science Centre was created beside the department in 2005. During recent years, other departments have been invited to take part, and the number of visitors has exceeded 9000 on this one night.

Professors dressed as famous scientists:
Albert Einstein (Leif Lönnblad, Theoretical Physics), and
Tycho Brahe (Ingemar Lundström, Astronomy)
together with Charles Darwin (Ronald Kröger)
and Carl von Linné (Eric Warrant) both professors
in funktionall zoologi.

Past – present – future

The historical narratives in the first part of this book were intended to tell a story. It is by no means the complete history of the development of physics in Lund, but rather a patchwork of stories with which we hope to bring its history to life.

History only comes to life when we see the people involved in making it. We have, therefore, concentrated on certain individuals, not only to describe their unique contributions, but also to show that a single person can make a difference.

During the course of this work, the obvious has become clear, that history does not stand still, that it evolves and is augmented by events from the present. History is changed by the discovery of new facts and narratives – the tale is never really complete.

In relating this story, the need to document the present became clear to us. This prompted a Department of Physics Archive to be set up within the library, which contains documents and images that reflect aspects of the development of research, over and above the purely scientific ones.

Apart from providing a reminder of what has been, we hope that this book will increase the reader's understanding of the present; if we know how it all started, and what happened, then it is easier to understand why we are where we are today.



Kristina Holmin Verdozzi, faculty librarian and head of the Physics & Astronomy Library, is production manager of the physics department history project and one of the editors of this book.

This is not a textbook, but describing the history of physics in Lund in a broader perspective sheds light on its role in the international arena. We have therefore combined developments in Lund with international discoveries and the explanation of physical phenomena.

Regardless of whether you are a physicist or not – regardless of your background – we hope that you will find something of interest to you in this book, and that you will learn something new that prompts you to look deeper into the fascinating world of physics.

The evident that deserves to be mentioned again is that it was not possible to include all the people and events that took place in forming the Department's history in this book. There are of course gaps, inevitable in any narrative. As soon as we decide on a text and an image, we become aware of what has been left out. We leave it to our successors to fill these gaps with new and old stories.

The final three chapters of this book deal with the transitions between the past, the present and the future. First, there is a discussion on the factors that led to success, which should be applicable to other disciplines apart from physics. This is followed by an interview with the current Head of Department on the present status of physics in Lund and prospects for the future. The final chapter describes where we are now, and provides some insight into which doors physics may be able to open in the future.



Annika Nyberg, photographer and graphic designer, has been part of the production team of this book. Within the History Project framework she has together with Bengt Forkman and Kristina Holmin Verdozzi also produced the large screen presentation on display in the Physics Department entrance hall, a memory game and a monthly calendar.

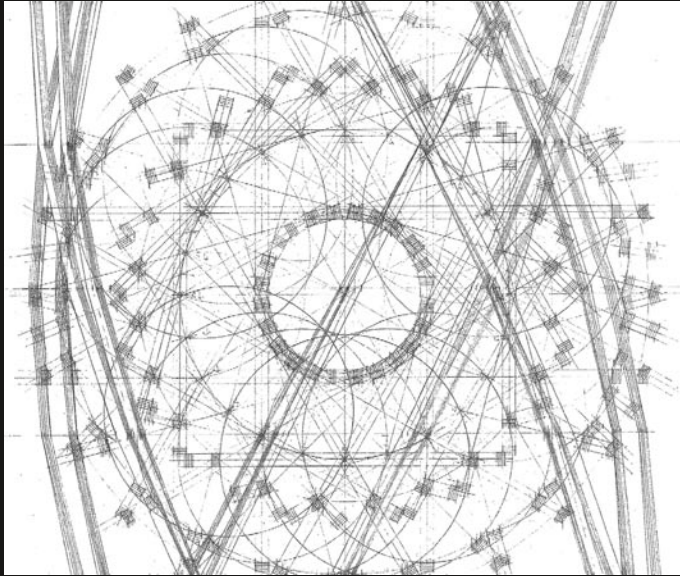

Discussions on the growth of physics in Lund

A discussion on the expansion
of the Department of Physics and
the secrets behind its success.

The success of physics in Lund

In an assessment of research in 2008, Physics was identified as the jewel in the crown of Lund University. During recent decades, the Department of Physics has expanded, resulting in a number of renowned research centres such as MAX-lab, the Lund Laser Centre, The Combustion Centre and the Nanometer Consortium.

What lies behind this development?

On a cold January day in 2014, The Historical Group at the Department of Physics and the Faculty of Science invited a number of people to participate in a discussion on the success of Physics in Lund, chaired by Professor Bengt Söderström.

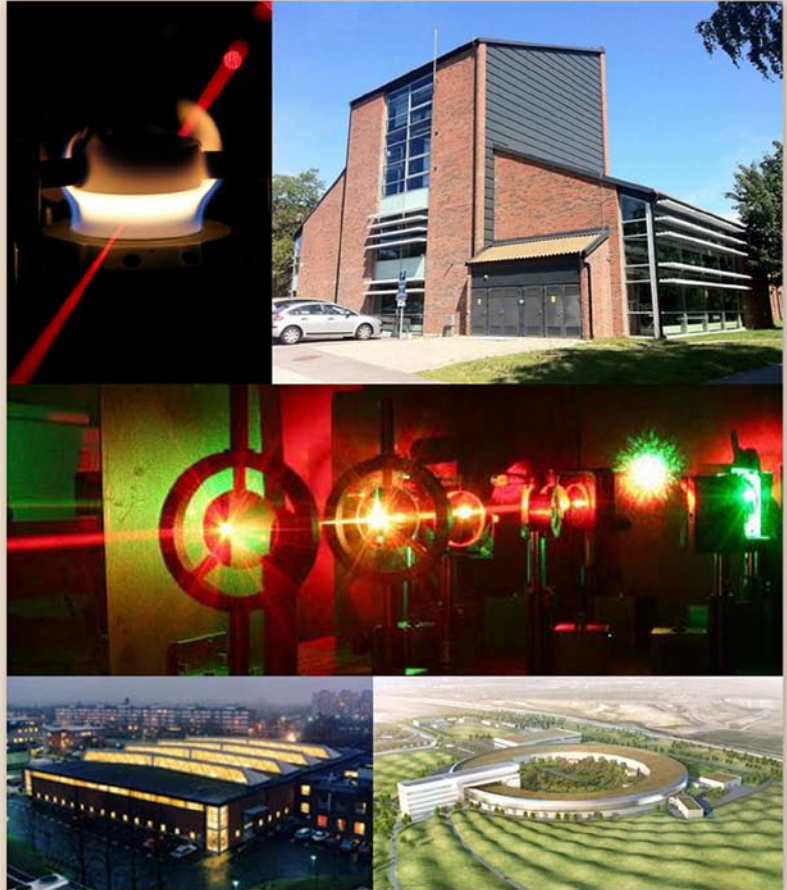

Visionaries

High scientific quality is fundamental, but ...

People are more important. Success is achieved through the determination of inspired people to realise their visions. Both visions and clear-sightedness are required for a particular area of research to be successful.

Leadership is key in this respect.

Peter Honeth

Peter Honeth, undersecretary at the Swedish Ministry of Education.

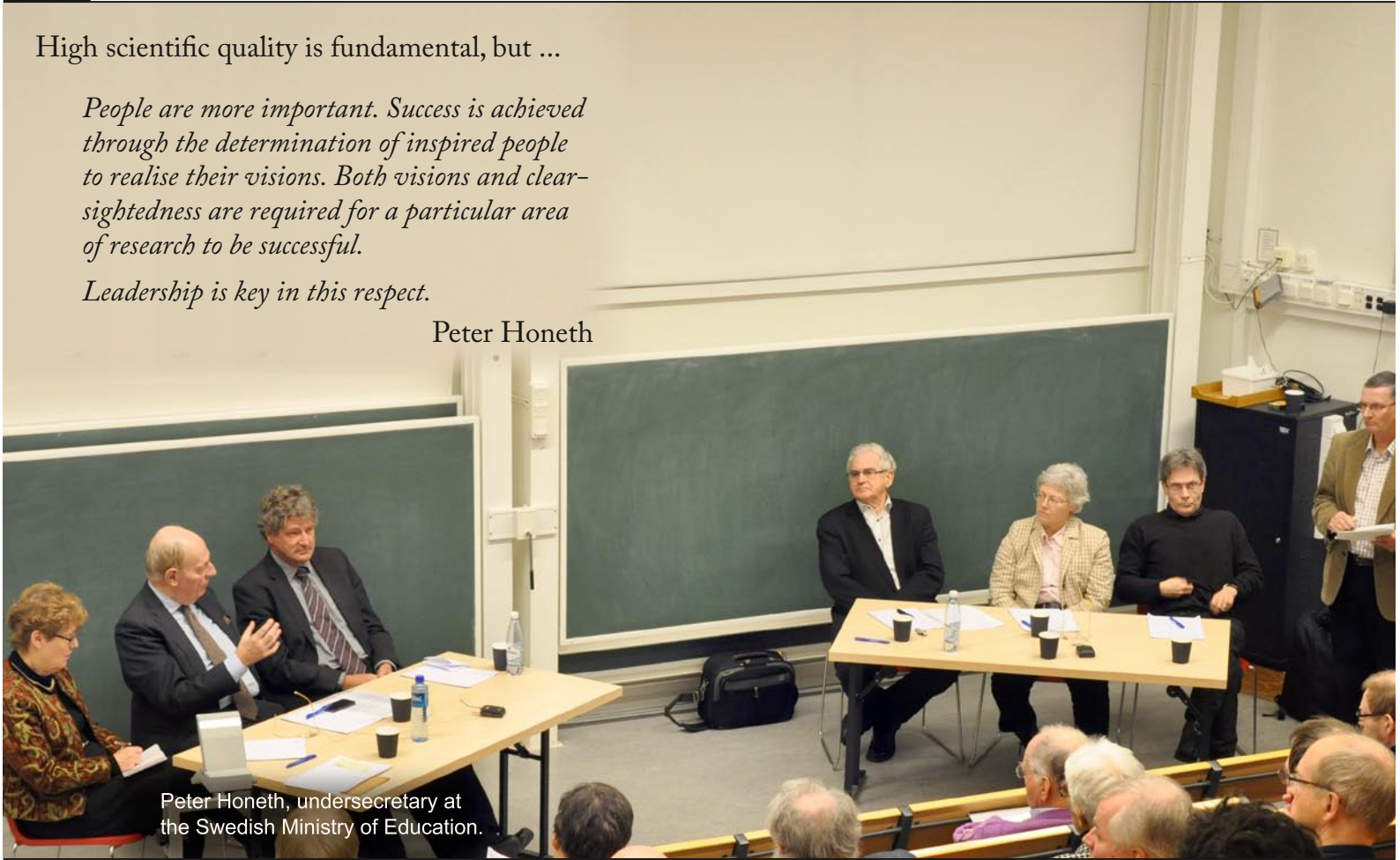



Having the courage to prioritize

Multidisciplinary research is an important factor, and there has been good cooperation between the two faculties. Physics has been especially successful – everyone was agreed that important research environments should be well-funded. Everything rests on high scientific and academic quality. But you must also have the courage to prioritize. It's important that both individuals and research centres work together.

Göran Bexell

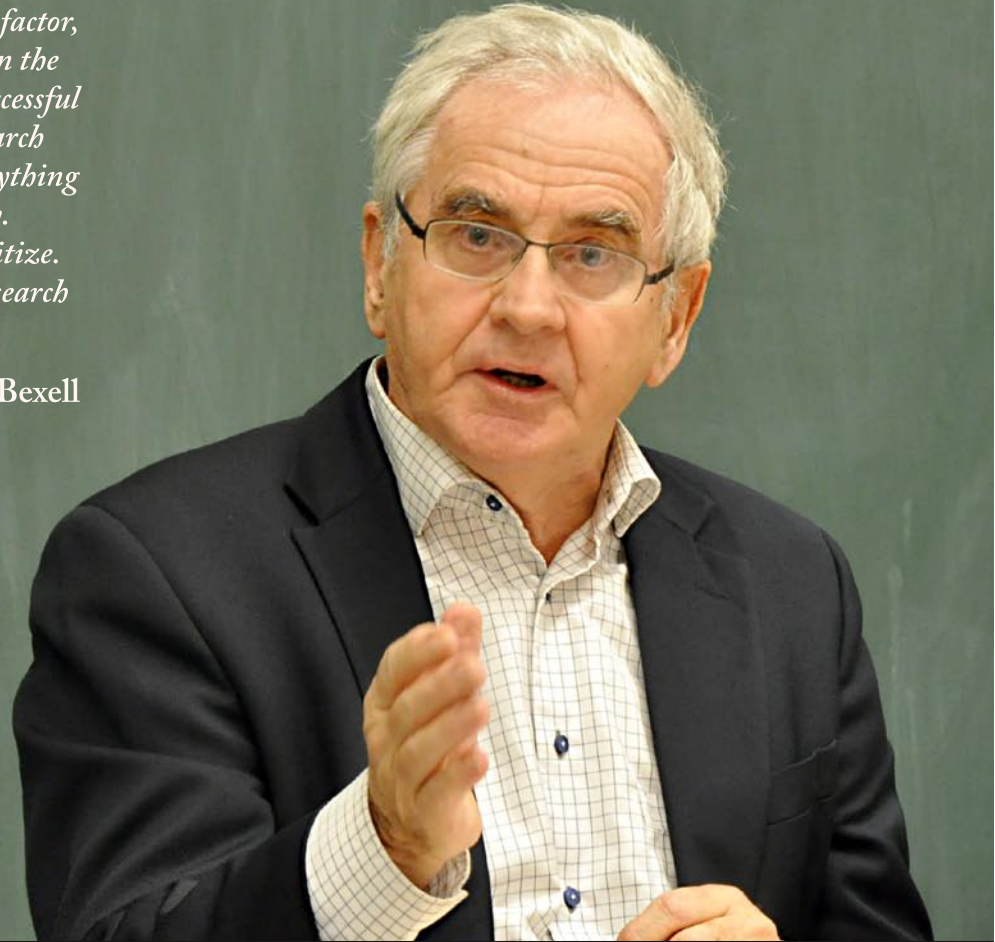

Professor Göran Bexell,
Former Vice-Chancellor of Lund University.

Seizing opportunities



You have to create opportunities, instead of waiting for them to present themselves. Researchers at the Department of Physics have always shown awareness of the developments taking place in the world over the past decades, and the changes in research policy towards areas in which there is strong competition.

They also knew how the funding system worked, both nationally and internationally. Seizing opportunities, while practicing reason and flexibility, has been important.

Mats Benner

Mats Benner, Professor at the Research Policy Institute, Lund University.

A harmonious environment



I have always felt welcome at the Department, it's one of its strengths. It's a harmonious department, free from conflicts, which makes it easier to cultivate contacts and initiate collaboration. It is easier for young scientists to flourish if senior staff don't feel threatened.

Another aspect is that a number of innovative researchers were responsible for successful ventures at the beginning of the 1990s. MAX II, the High-Power Laser Facility, the Combustion Centre, the Nanometer Consortium – they were all established then.

Anne L'Huillier

Anne L'Huillier,
Professor of Atomic Physics, Lund University.



Broad horizons

Contact with industry has also been important for the development of the Department of Physics, while industrial collaboration has in turn benefitted basic research. Multidisciplinary research involving several faculties has also been of considerable importance. Physics is fundamental to many other fields, such as engineering and medicine. Lund University has also been quick to reward success.

Pär Omling

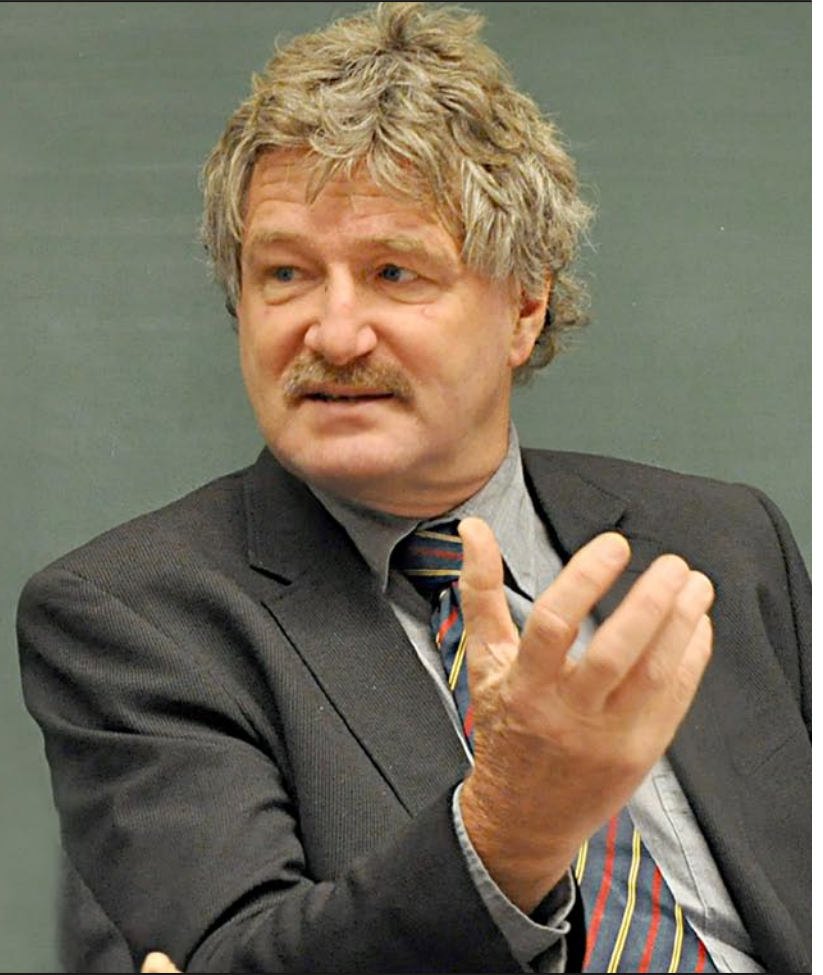

Pär Omling, Professor in Physics, Lund University.

Financing



Bengt Söderström, Professor at the Department of Biology, and former Dean of the Science Faculty at Lund University.

The Moderator for the discussions, Bengt Söderström, directed the discussion to the importance of diversity in funding.

Government funding of research and post-graduate studies remained basically unchanged in real terms from 1997 and 20 years ahead. Since then, it has increased by between 400 and 500 SEK million (€40-50 million). There are indications that these funds are being used to finance positions that lack full funding, whereas it would be better to use them to finance junior researchers. However, Swedish universities have very decentralized organizations, so it is difficult to impose long-term strategies.

Peter Honeth

In Sweden, competition for funding is greatest early on in a researcher's career, while in other countries it is often the opposite, for example, 'incubators' are set up for young researchers.

Mats Benner

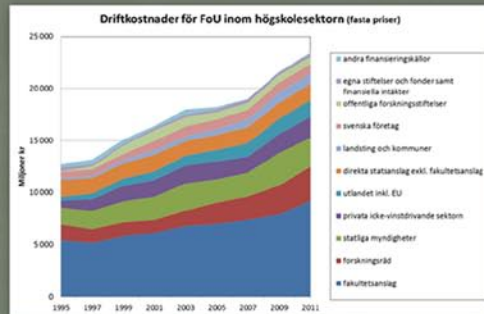

Fixed costs for research in terms of the values in 1995.

Collaborations



Lena-Kajsa Sidén, Peter Honeth, and Pär Omling.

We need different kinds of financing, but external financiers should not be responsible for funding our basic activities. Universities must show that they can take responsibility for long-term strategic planning for the use of funds. If they can do this, it would be better to increase government funding to the faculties than to apportion funding via the Science Research Council and other funding bodies.

Peter Honeth

Multiple financiers?

Göran Bexell, Anne L'Huillier, and Mats Benner.



It is good to have many different financiers, but you have to set a limit as too many will lead to problems, especially in recruiting students.

Mats Benner

It is good to have many financiers, but it is wrong to talk of them 'owning' a project – they have the pleasure of being responsible for funding it.

Pär Omling

Can one buy competence

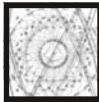

It's possible, but not easy. It isn't always easy to keep up in new fields of research, so you have to be prepared to bring in new competence.

Peter Honeth

Lena-Kajsa Sidén commented on the consequences of recruiting researchers with key knowledge:

When a dynamic professor leaves a university it may be necessary to simply cease research in that particular field, in other words, you can't expect a research group to perform well without strong leadership.

Lena-Kajsa Sidén

Lena-Kajsa Sidén, analyst at the Swedish Foundation for Strategic Research.



Balance and competition



Anne L'Huillier

As long as external opportunities and internal capacity are balanced, there's no problem. A strong environment is willing to expose itself to idea-based competition.

Mats Benner

Other activities that are not expanding very rapidly in a department should not feel threatened. If things are going well in one field, they will go well in all fields.

Anne L'Huillier

Factors affecting development

... the greatest danger lies in trying to continue in a field of research when its importance is waning. It is important that those in executive positions follow developments in research and are aware of the changes taking place.

Peter Honeth

It is important to remember that research is carried out by individuals, and this requires creativity, in the same way that artistic work does. A supportive organization that makes strategic decisions regarding priorities is also necessary.

Göran Bexell



The future of the Physics Department

Which areas of physics can we expect to expand or stagnate?
How will this affect the Department of Physics financially and in future needs for premises?

– Research is being carried out at the Department in nearly all fields of modern physics. Many of these have considerable potential, and all of them are expected to expand in the future, although at different rates. Particle physics beyond the standard model is one example where enormous fields of research are opening up, as well as research in superheavy elements, new findings on the nucleus and research on dark matter.

– Aerosol physics and the formation of particles is one area we still know too little about, but which can lead to research in environmental physics, including the working environment, climate and health. This is an area in which we can help tackle the considerable challenges facing us. Environmental physics is not just a case of analysing clouds, but also the spectroscopic measurements that Sune Svanberg¹ initiated. They are still important, and these methods are now being used in biology and other areas, and can also be expected to expand.

– Nanophysics, quantum information, laser technology, and accelerator and detector technology are other research areas from a long list, although we can't do everything. Graphene, for ex-



Knut Deppert is head of the Department of Physics.

ample, is an important area of research that we're not involved in at the Department.

– During the past ten years, the Department has grown by about 35%, which has made our premises somewhat cramped,

although I don't expect the same rate of expansion in the future. The financial situation is good, but we are constantly competing for external financing.

It is likely that many areas bordering on other sciences, apart from the fundamental research in physics like dark matter, also will develop. Will this create a need for reorganisation?

– Yes, partly administratively, and partly in the way we work. Our administration is a system, a matrix or a linear organisation, in which work is carried out in two faculties, the Department and several divisions. Then we have a number of research centres and consortia – NanoLund and the Lund Laser Centre, for example – which cross these boundaries. This has considerable advantages, providing we can handle it pragmatically. Problems and conflicts of interest can arise when interdisciplinary organisations are involved.

The organisation of a department is very important for the working climate and the distribution of funds, amongst other things. Should we be actively involved in creating new projects, or should we help other subjects to make use of our knowledge?

– Both. We need detailed knowledge in all kinds of things, from technical instruments to theory, if we are to be able to understand our fields. At the same time, we must make sure that the advanced basic research carried out at the Department can be

put to use in everyday life. Working together with scientists from other subjects inspires our own research. Examples of this are the application of physical methods in geology and biology.

The Department is strongly connected to MAX IV; should we also develop research adapted to the ESS?

– Yes, we have strong ties with MAX IV as MAX started here at the Department. We'll definitely have strong ties to the ESS in the future, probably not a whole division devoted to it, but perhaps one for material physics. We're already engaged in research in accelerator and detector development, and we plan to develop a field of research on magnetic materials that can be important for the ESS.

There appear to be differences between the relations between professors at the Department of Physics and those at other large department? We seem to work together, while they perhaps compete with each other. Why is that, do you think?

– That's a very difficult question to answer. It's important that the staff at a department want to work together. We have a relatively conflict-free environment at the Department of Physics, which provides a good basis for young researchers to progress, and facilitates new contacts and collaboration. The Department is also fortunate in having many dedicated scientists with visions that have paved the way for success.

– At some other departments they seem to change the names of divisions and affiliations rather often, which could cause conflict.

– At the Department of Physics we have continuity, and although the name Combustion Physics, for example, only partly covers the research carried out at the Division, it seems that everyone has a clear identity and affiliation. The Division of Solid State Physics, for example, could be a Department on its own if you look at its size and budget, but they think it's important to belong to Physics in Lund, and they think it's important to belong to the Department of Physics. We also want close connections with theoreticians, and others working close by, for example biophysicists, medical physicists and other neighbouring fields. There should be so many advantages associated with a department that you want to be part of it.

– Belonging to two different faculties, as we do, has both advantages and disadvantages. We have to follow two different financial distribution models and, as Head of Department, I have to attend twice as many meetings, and I get twice as many e-mails, but we have greater flexibility and better control over our situation.

A few years ago, the umbrella organisation *Physics in Lund* was born, a common gateway for physics, astronomy, theoretical physics, medical radiation physics and parts of MAX IV. Was that a good idea? Why not a Physics Centre?



Knut Deppert

– When I became Head of Department there was a lot of discussion about combining all the physics-related fields into one unit. This didn't materialise, but we agreed on ways in which we could work together, which still prevail today, and which work well. We have no obligations, only opportunities, and the heads of all the departments involved are better prepared before going

to the Management Council. So collaboration has developed, but Physics and Astronomy are still two separate departments. It might look strange from the outside, but we are able to cooperate without being restricted by organizational borders.

A question about freedom in research: How dangerous is commercialisation? Should we form spin-off companies?

– I don't see any danger in commercialisation. I think it's good that research can lead to new products and new employment opportunities. The danger lies in thinking along commercial lines – trying to run the University like a big company – that's dangerous. Take quarterly reports, for example, which I think are stupid even in commercial enterprises. There can't be any long-range planning in a company controlled by quarterly financial reports.

Why isn't the Department of Physics more visible in the public arena? Is this related to commercialisation? Might some researchers be afraid to make public statements in case their financiers don't approve?

– I haven't noticed this. We take part in debates on issues related to physics. We can't be everywhere at once because we don't have the time – we have to give priority to other things. We're busy submitting applications and writing reports, and reading reports that others have published.

Is it possible to stimulate popular scientific activities?

– That's an interesting question, but I don't really have an answer to it. Some real enthusiasts could probably do this, but they don't have the time. We won't be able to get around this problem unless we devote specific funding and resources to it. Still, many of us think this is important, and we do what we can. We're involved in a number of activities such as Knowledge Week and High School Week and the Lund Culture Night. We give physics and laser shows, we're represented in the Lund Science Center, give popular scientific talks in schools, and have good cooperation with high schools.

Let's turn to teaching. Do we give our students the best education we can?

– Well – there's always room for improvement. However, we have to cut our coat according to our cloth – we can only do the best we can with the resources available. But there's still potential for improvement. One of our greatest challenges is that the students are not such a homogeneous group as they were 20 years ago regarding their knowledge and expectations. This places higher demands on how we treat our students and how we educate them.

Is teaching at universities in crisis, as it is in schools?

– Not yet, but it will be. The reason for this is constant savings

in administrative resources, which means that we're spending our time documenting instead of teaching. Like doctors, they're spending more and more time on patient records and less on their patients. We have to be prepared for this crisis now, and as I see it, we must be able to provide teaching at a more advanced level. For example, we could do this by drastically reducing the intake of students to only a tenth of the numbers we admit today or, as Torsten Åkesson has suggested, leave the teaching at Bachelor's level to smaller universities, and focus on teaching at Master's level.

Not everyone would agree with you. Many believe that students should be introduced to research as soon as possible, as this stimulates those who are interested, but this isn't possible at smaller universities. How do we balance quality and quantity?

– I agree that it's stimulating for young students to come into contact with spearhead research. That's why there are already many opportunities for our students to do this early on in their education.

How can we increase respect for teaching? For example, by grants to research students who are interested in teaching? How can we stimulate researchers to teach – grants? diplomas?

– If you look at the distribution of funding, it appears that teaching has lower priority than research, but we have many commit-



Håkan Ivansson is Technician at the Course Laboratory. He prepares the experimental exercises used in teaching, carries out repairs and other requests from the divisions at the Physics Department.

ted researchers at the Department who believe that teaching is an important part of their work. Our policy is that there should be a close connection between research and teaching, and when appointing new researchers they must also demonstrate pedagogic skills and the desire to become involved in teaching.

Does teaching work differently here in Lund compared with other universities? We became aware of this when working on the book on MAX Lab. Ingolf Lindau discovered, for example, that only a small minority of academic staff teach in Lund, while everyone was involved in teaching at Stanford.

– Yes, things work differently here. I've heard that at Gothenburg and Uppsala researchers have to teach if they don't get funding for their projects, but we don't do that. We try to find a good balance between the limited funds available and our ambitions regarding teaching. We try to make sure that the best lecturers teach, and that students get the best teachers in their first year of studies.

Have we ever tried to employ someone who is first and foremost a really good teacher, or have we always recruited teachers from among our own staff?

– I don't know what happened previously, but in recent years we have usually chosen someone from among our leading researchers and demanded that they also should teach well.

A personal question – where do you come from?

– I grew up in East Germany, the DDR, and studied and got my PhD in Berlin. During my period as a postdoc, we collaborated with Lars Samuleson⁴. After the fall of the Berlin Wall he offered me a one-year position in Lund as a visiting researcher – and I'm still here!

How was German administration? I've heard that East and West Germany were completely different.

– Oh, absolutely, the DDR and the West were quite different. Things have changed during just one generation – like China after the Cultural Revolution.

No one in Sweden likes to put their foot down – we discuss things 'in absurdum' in meetings and committees, is this your experience?

– Yes, that's right, but there are advantages and disadvantages with this. When leading an organisation you have to strike a balance between dictatorship and anarchy. Sweden has found a middle path between these two extremes.

Is there any difference in the culture in physics between Germany and Sweden?

– I think Sweden has a more open culture than Germany. And

Marianne Madsen is Librarian and carries out information requests from students and researchers.



Kerstin Nilsson works as a teaching administrator including management of courses and education issues at the Course Laboratory.



then Sweden has, in a somewhat fantastic way, proven to the world that you can nominate Nobel laureates.

Are things more hierarchical in Germany?

– Yes, absolutely, but it's getting better. You can even come across professors in Germany who leave their doors open these days!

Walking around the Department of Physics you'll see more men than women, why is that?

– We have a number of very capable female students, about 30% of our students are women, at both undergraduate and postgraduate level. There's a small but gradual increase in the

number of female PhD students and staff. However, there's a constant pressure to perform well here, which some people may find daunting. You could also ask why there are hardly any men among the administrative staff, or hardly any women among the technical staff. Among the teaching staff, about 20% are women. Equality is not just about numbers, it's also about enjoying your job. This means that we must not project our own opinions and expectations on our colleagues, but regard them as independent individuals that perhaps don't fit our own idea of what is normal. Regularly questioning our own conceptions of what is normal can be enlightening! There is no law of nature that says that women are better at making coffee or men are better at changing fuses. Equality is about attitudes and awareness.



Karin Larsson has worked as a cleaner at the Department of Physics since 1997 and together with her colleagues, she takes care of the in total 20000 square meters.

What are your views on functions that support teaching and research, such as the library and administrative services? Are these strategically important resources?

– Of course we need support services like the administration and the library. Those employed in these services, including communicators, seem to always have to defend their existence. No one thinks about the library until something goes wrong, in the same way that people complain if the corridors are dirty, but no one says anything when they're clean.

– The IT revolution has not only changed libraries as we know them – today digital services via IT-based systems are important in many areas. However, digitalization places demands on the competence of staff – they have to be able to work with these systems and provide good support.

– Here at the Department of Physics, we have a small, but efficient, group of competent and loyal administrators offering support. I think physical proximity to our core activities is important in this respect.

How can we show that MAX started here?

Libraries are necessary to document and present our history. German institutions are usually very good at doing this.

– Naturally, we should be proud of our history and make it known. This book is a good example.



Annika Nilsson is Librarian at the Department of Physics including teaching information retrieval to physics students. She is also the Physics Department communication officer.

Do you think the Department of Physics should move up to the Science Village to be close to MAX IV and the ESS?

– The future promises to be exciting for physics in Lund thanks to the construction of two large research facilities just outside the city. MAX IV was inaugurated in June 2016, and with it the start of research using the world's strongest light source. The ESS, a next-generation neutron research facility, is being built nearby, in an area called Science Village Scandinavia. This has



Stefan Schmiedel is the janitor of the Physics Department. Each working day he takes over 10 000 steps delivering the daily mail to employees at the department.

led to plans by the University to establish a campus at Brunnshög in the same area, where research and teaching can be carried out in close association with these facilities.

– The University should have a complex at Brunnshög, not a single establishment, but a campus. There's room for both the Natural Science and Engineering Faculties, but that doesn't mean they should move there entirely. One building could house interdisciplinary projects, with a library and an exhibition area, as well as facilities for teaching, research and popular scientific activities. It might also be a good idea to move part of the Lund University Hospital to Brunnshög, after all, there will be a fantastic X-ray facility!

-
1. Professor in Atom Physics.
 2. Professor in Particle Physics.
 3. Professor in Synchrotron Radiation Physics.
 4. Professor in Solid State Physics.

Topics from modern physics



Anne L'Huillier

When I started my studies in physics, almost 40 years ago, I found the subject fascinating, although not as exciting as I do today. This may seem strange as instruments and methods have improved, theories have been refined, and many discoveries have been made over the past 40 years. Our understanding of the laws of nature has definitely increased, but new questions have also come up. Nature is, more than ever, both a difficult and a beautiful puzzle.

Physics is the science of nature at a fundamental level. It extends from particle physics, in which the smallest building blocks of matter are studied, to astrophysics, the study of the universe. Physicists are not only engaged in studying nature, but in the development of tools that lead to new science, solve societal challenges or provide a better daily life. The intention in this short summary is not to review the whole of physics, but to highlight some interesting aspects of modern physics.

Exoplaneter

Planets that orbit a star outside our solar system, were discovered in the 1990s, and have already become part of nature as we understand it. Over 3000 exoplanets have been discovered so far, and the number is increasing every year, with the development of observation techniques. Several techniques can be used to detect planets. The method used to detect the first exoplanets is based on measuring the variation in the radial velocity of a star caused by the Doppler shift of spectral lines. (figure below). Today, most observations are made with the help of satellites, using the so-called transit method, in which the periodical variation in the luminosity of a star, due to the passage of the planet in front of it, is measured. A surprising discovery is that there are large, heavy planets with very short periods of revolution, and thus high temperatures, in contrast to our own solar system.

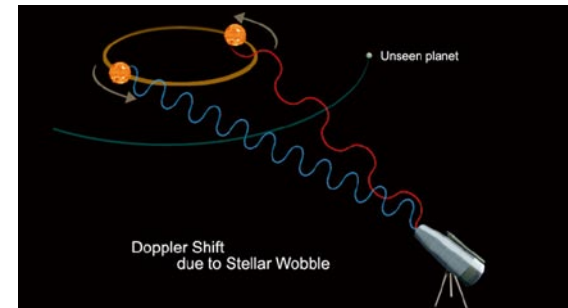

Observation of planets using the Doppler technique.

Planets have also been discovered in the so-called ‘habitable’ zone, where liquid water may be present, suggesting the possibility of life.

Black holes and gravitational waves

Black holes are massive, dense objects, whose gravitational field is so large that no radiation can escape from them. It is therefore impossible to see black holes directly, but the effects they have on their surroundings can be observed. Black holes can have masses ranging from several tens of solar masses to millions or even billions of solar masses. These gigantic black holes are expected to be found at the centre of galaxies. The enormous black hole at the centre of our own galaxy, in the Milky Way, has been predicted by studying the orbits of the stars closest to the centre of the galaxy, which are affected by the presence of this huge mass. New evidence for the existence of black holes came recently, in September 2015, with the detection of gravitational

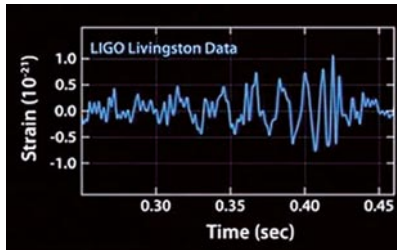

The detection of a gravitational wave.

waves. The detector used for this is an impressive optical instrument called LIGO (the Laser Interferometer Gravitational-wave Observatory). LIGO consists of two large, very accurate, Michelson interferometers, separated by a distance of 3 000 km; one in Livingston, Louisiana, and the other in Hanford, Washington, USA. The variation in space-time caused by gravitational waves leads to a difference in the lengths of the arms of the interferometers, which can be measured with almost incredible accuracy. The gravitational signal, which lasted only a fraction of a second, is thought to be a consequence of the fusion of two black holes thousands of millions of light years away.

Cosmology

The study of the history of the universe has developed tremendously during recent decennia thanks to accurate measurements of the cosmic background radiation in the microwave range (using, for example, the Planck satellite, measurements of the expansion of the universe (by studying supernovae, i.e. large exploding stars), and mapping of the distribution of galaxies in space. The history of the universe is described by a cosmological model that starts with the Big Bang, when the universe was very small, dense and hot. The model includes 68% *dark energy* which causes the expansion of the universe to accelerate, 27% *dark matter*, and less than 5% *normal matter*. Several kinds of observations have provided and less than 5% *normal matter*. Several kinds of observations have provided evidence for the existence of dark matter, but we do

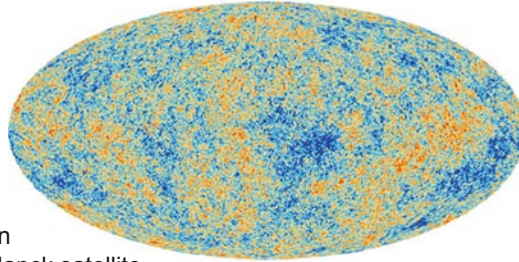

Cosmic background radiation observed with the Planck satellite.

not yet know what it is. One hypothesis is that it consists of heavy, weakly interacting particles, which scientists are now searching for in several experiments, both here on earth and in space.

Particle physics

Within particle physics, the laws of nature and the basic building blocks of matter are studied. Experiments require high-energy collision processes to reach the resolution of the smallest subatomic particles. Large accelerators are therefore needed, such as the LHC (Large Hadron Collider) at CERN in Geneva, and experiments are performed by large research groups, sometimes consisting of several thousand scientists. The laws of nature and elementary particles are currently described theoretically using the Standard Model, which has been experimentally verified to high accuracy.

These basic building blocks and particles are called elementary particles, and include material particles such as quarks and leptons (examples of which are electrons and neutrinos), and parti-

cles that mediate the four fundamental forces in nature. Each of the material particles has a corresponding antiparticle. Hadrons, for example, neutrons and protons, are made up of quarks, while antiprotons, for example, are made up of antiquarks.

Three kinds of force-mediating elementary particles have been observed: Gluons (the strong force), photons (the electromagnetic force), and W and Z bosons (the weak force). The particle mediating the gravitational force, the graviton, has not yet been experimentally observed.

In 2012 the Higgs particle was detected in two experiments, ATLAS and CMS, at the LHC. This was a major triumph for particle physics as the BEH (Brout–Englert–Higgs) mechanism and the Higgs particle had been predicted almost half a century earlier to give mass to elementary particles, and could now be confirmed.

Tre generasjoner av materia (fermioner)

	I	II	III		
masse	2.4 MeV/c ²	1.27 GeV/c ²	171.2 GeV/c ²	0	~126 GeV/c ²
laddning	2/3	2/3	2/3	0	0
spinn	1/2	1/2	1/2	1	0
namn	u opp	c charm	t topp	γ foton	H Higgs boson
Kvarkar					
	4.8 MeV/c ²	104 MeV/c ²	4.2 GeV/c ²	0	
	-2/3	-1/3	-2/3	0	
	1/2	1/2	1/2	1	
	d ner	s sår	b botten	g gluon	
	<2.2 eV/c ²	<0.17 MeV/c ²	<15.5 MeV/c ²	0	91.2 GeV/c ²
	0	0	0	0	1
	1/2	1/2	1/2	1	0
	ν _e elektron neutrino	ν _μ myon neutrino	ν _τ tau neutrino	Z ⁰ Z boson	
Leptoner					
	0.511 MeV/c ²	105.7 MeV/c ²	1.777 GeV/c ²	80.4 GeV/c ²	
	-1	-1	-1	+1	
	1/2	1/2	1/2	1	
	e elektron	μ myon	τ taulepton	W [±] W boson	

Gaugebosoner

The Standard Model.

The most common elementary particles in the universe after photons are neutrinos. They are created by the weak force, for example, in stars, and interact extremely seldom with matter. For example, they can pass through the earth without being stopped. It was long thought that neutrinos had no mass. By measuring the neutrino flux in large detectors deep underground, scientists have been able to show that neutrinos can change character during their passage through the earth, for example, from muon to tau neutrinos. These so-called ‘neutrino oscillations’ mean that neutrinos have a mass. So far, we have only been able to determine the upper limit on this mass, but we know that the lower limit is not zero.

Particle physicists are now excited about new discoveries that will take us beyond the Standard Model. There are many competing theories, but experimental guidance is needed to show which one best reflects nature. We have to know what lies beyond the Standard Model to be able to explain, for example, what dark matter consists of, and why the universe consists mostly of matter, and not equal amounts of matter and antimatter.

New elements

One area of modern research in nuclear physics is concerned with creating and studying extreme nuclei, for example, those with a high ratio of neutrons to protons, or those that are non-spherical, for example, pear-shaped. Another interesting question is how many protons and neutrons a nucleus can have with-

out spontaneously decaying. Very heavy, short-lived nuclei can be made through fusion, which can lead to the discovery of new elements. Recently discovered elements have been given the names nihonium (Nh, with atomic number $Z=113$), moscovium (Mc, $Z=115$), tennessine (Ts, $Z=117$) and oganesson (Og, $Z=118$). These elements complete the seventh row of the periodic table, and the hunt for elements in the next row can start.

Cold atoms and condensates

Atoms and their interactions with, for example, light, are studied in atomic physics. So-called *cold* atoms are often used in experiments. These are achieved by cooling them to temperatures of micro- or even nanokelvin using various techniques often laser-based. In 1995, scientists were successful in cooling a gas of alkali atoms so that a Bose-Einstein condensate was formed. The figure on the right shows the condensation of rubidium atoms. These atoms are bosons, and if they have a sufficiently low energy and are sufficiently close together their wavefunctions will overlap, and the atoms will be in the same quantum mechanical ground state. Condensates have many interesting properties that can be used in various applications. The atoms in a condensate move coherently (i.e., together), just like photons in a laser beam. It is considerably more difficult to cool fermions to extremely low temperatures, and thus form a condensate, as fermions cannot be in the same state (according to the Pauli principle). Despite these difficulties,

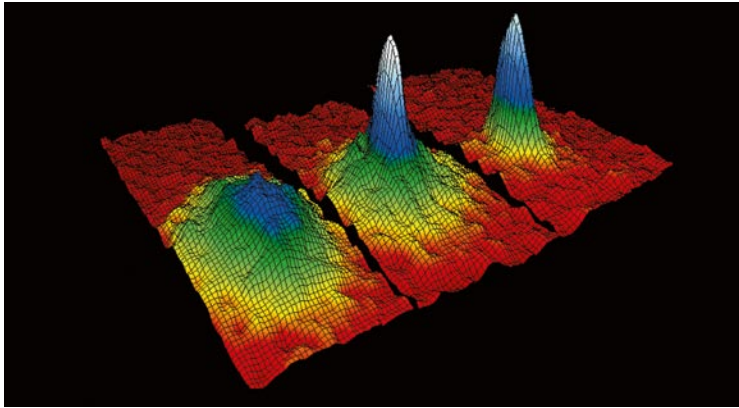

Formation of a Bose-Einstein condensate.

scientists have recently been able to condense fermions by forming *bosonic molecules* consisting of two *fermionic atoms*.

Quantum technology

Our microcosmos is described by a theory developed almost a hundred years ago, quantum mechanics. Within quantum mechanics, matter behaves in a strange way: for example, a particle is not only a particle, it can also be a wave; its exact position and velocity cannot be determined simultaneously; and a particle can be in a superposition of different states. Particles are seldom isolated, and interact strongly with their environment. An ensemble of particles behaves differently from an isolated particle, and is often described using classical mechanics. The idea of an

experiment using a single particle has long been an intellectual exercise. However, in recent years, methods have been developed for manipulating isolated ions in a trap, or a few photons in a cavity. These methods have many applications, from fundamental studies of the foundations of quantum mechanics, such as the transition from quantum mechanics to classical mechanics, to a new generation of atomic clocks using optical transitions in extremely stable, isolated ions.

Quantum mechanics also leads to intuitively bizarre predictions if one considers two (or more) particles in a so-called entangled state. When a measurement is made on one particle, it affects the properties measured in the other, even if they are a considerable distance apart. Experiments carried out at the end of the 20th century showed that these strong correlations could not be explained by a description based on a very intuitive local realism. Local realism assumes that an object exists, regardless of whether you are observing it or not (realism), and that it is only affected by its local environment (locality). Expressed more scientifically, the principle of local realism means that an object cannot be affected by another distant object at a speed faster than the speed of light, according to Einstein's theory of relativity.

As a result of basic research on the non-locality of nature, new ideas were conceived and developed where quantum mechanical properties were used in various applications. For example, information can be transmitted with complete security using quan-

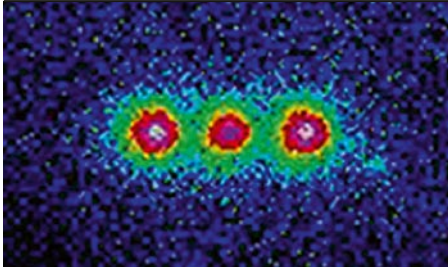

Three Be ions.

tum cryptography, because if someone intercepts the message, both the sender and the receiver will be aware that the message has been intercepted. It is now possible to buy quantum cryptography equipment. Another application, which is still a vision of the future, is the quantum computer, which uses quantum bits (a superposition of two states, often called 0 and 1) instead of normal bits (0 and 1) for calculations. This application makes use of the natural parallelism in quantum mechanics, allowing simultaneous calculations with the superpositions of 0 and 1, and not first with 0 and then with 1. Several suggestions have been made regarding the physical components of a quantum computer, from trapped ions, to cold atoms and superconducting Josephson transitions. These components are already being used as *quantum simulators*.

Laser radiation

Our ability to control light has been improved considerably over recent decades. Lasers have revolutionized both science and eve-

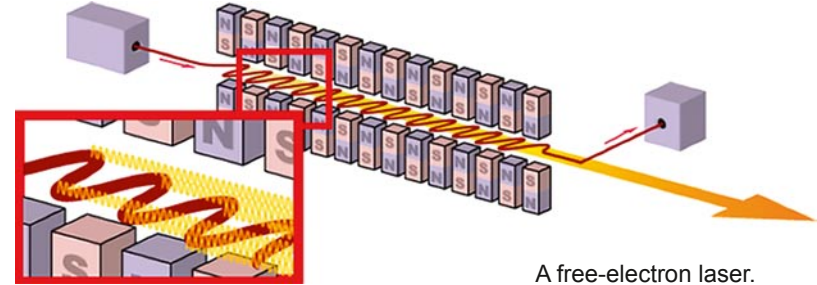

A free-electron laser.

ryday life. Laser research is being pursued in several directions: to increase the power, both the average power and peak power (which today is in the petawatt (10^{15} Watt) range), to extend the wavelength range, from the X-ray region to the infrared; to shorten the pulse length (down to a few femtoseconds) and, finally, to improve the coherence (which means that the beam propagates at exactly the same frequency, amplitude and phase over a long period of time). Conventional lasers make use of the transition between two levels in an atomic or molecular system. Energy is pumped into the system so as to cause a population inversion between the two levels. Today, laser light (or laser-like light), can also be created using new physical processes. In parametric processes, energy is never stored in the medium, but is converted from one kind of light to another. An example of this is high-harmonic generation in a gas, which leads to very short light pulses in the extreme ultraviolet region, with pulse lengths of only a few tens of attoseconds ($1 \text{ as} = 10^{-18} \text{ s}$). A free-electron laser makes use of relativistic electrons from a linear accelerator.

Radiation is produced by the oscillation of pulses of electrons in an undulator, which consists of a row of magnets with alternating poles (as shown in the figure). The radiation is coherently amplified as the pulses of electrons are modulated in a well-defined way by the light they generate. Free-electron lasers today can produce laser pulses with wavelengths in the X-ray region.

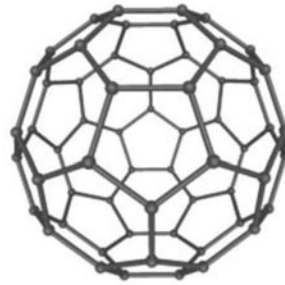

fullerene

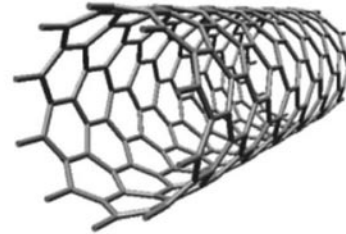

nanotube



graphene

Carbon-based nanostructures.

Matter

As in the case of lasers, our knowledge concerning matter and our ability to control it have increased dramatically in recent decades. Older textbooks describe matter as being solid, liquid or gas. Today, this is far too simple a picture. Examples of other phases of matter are magnetic phases, superconductors, superfluids, plasmas, gels, polymers, etc. Within condensed matter physics, solid materials are classified as ordered (i.e., crystalline) or disordered (i.e., amorphous, such as glass). Band structure theory is used to categorize crystals as metals, insulators or semiconductors. But even this is too simple. A new area of research within the physics of condensed matter is concerned with creating materials that are good bulk insulators, but which are electrically conducting on their surface. Smart semiconduc-

tor structure designs have also opened up completely new research fields in low-dimensional systems.

Materials research leads to numerous applications. Semiconductors such as silicon (Si) and gallium arsenide (GaAs) form the basis of our increasingly powerful computers and mobile phones, and for fiberoptic communication, all of which have revolutionized our daily lives. Other applications include the development and production of materials suitable for efficient solar cells, which become increasingly more important for energy production, and materials for light emitting diodes, which can be used to produce light sources that are at least ten times more efficient than normal light bulbs.

Another successful development in solid state physics is nanote-

chnology. New techniques have made it possible to manipulate matter on the molecular scale, between 1 and 10 nanometres. Examples of nanomaterials with a single layer of atoms are carbon structures such as fullerenes, carbon nanotubes and graphene, a two-dimensional crystal (as shown in the figure). Other nanostructures, such as nanowires and quantum dots can also be produced from metals and semiconductors. There are many fields of application, for example, in medicine, photonics and electronics.

Nanostructures are usually investigated with electron microscopy, which has reached an almost unbelievable precision, making it possible to study nanomaterials on the atomic scale. Another method that has revolutionized materials science is scanning tunnelling microscopy, which is based on the concept of quantum tunnelling, strongly dependent on the distance to the surface. The surface structure of an electrically conducting material can be mapped on the atomic scale ($\sim 0.1 \text{ \AA}$) by scanning an extremely narrow metal tip (of the order of a few atoms) over it. Atomic-force microscopy, which measures the atomic forces between the tip and the surface being studied, can also provide fine-detailed information on biological materials, which are not usually sufficiently conducting for scanning tunnelling microscopy.

A plasma is a material phase that contains free electrons and ions. Plasmas are found naturally in stars and interstellar space. They can also be created in the laboratory, and are used in fusion research, where scientists are attempting to bring about the fusion of tritium and deuterium (isotopes of hydrogen) to make

helium and energy, using high-power lasers or high magnetic fields (tokamak). The aim is to produce more energy than has to be supplied to induce the fusion reaction in order to develop a fusion-based power plant.

On the borders of chemistry and biology

Apart from purely physics research, new areas are constantly being developed that involve, for example, chemistry or biology. One example of this is optical microscopy beyond the diffraction limit, which makes use of ingenious laser techniques combined with light-emitting chemical compounds, and is used in biology and medicine. Another example is the use of methods developed in statistical physics to predict the development of a virus population and for the study of neural networks.

Despite the enormous advances made in recent decades, or perhaps because of them, we are facing many new questions such as whether or not there is life outside our solar system. Gravitational waves provide us with a new way of regarding the universe: What will it look like? What is dark matter? Why does matter dominate over antimatter? Will physicists be able to describe gravitation (and find the predicted elementary particle, the graviton) together with the other forces of nature in a unified way? When will quantum computers or fusion power plants be realized, and what will they look like? What new inventions will help save lives on our planet?

Physics is more exciting than ever before!

**Suppliers of photographs / illustrations
from private archives and albums**

Annika Nybergs family archive: 104 (birds),
165 & 176 (ultrasound image, 2002), 174 (aquarelle, 2004).
Birgit Hertz (photo): 166, 168.
Birgit Nordbring (photo of Birgit Nordbring): 173.
Cecilia Jarlsskogs photo archive: 194.
Donald E Davis (painting, 1994): 124.
Gunnar Källéns family archive (photo): 186, 190 (1951), 191, 195.
Gösta Gustafson (photo): 67, 73, 74, 330.
Hans Siegbahn's family archive: 49 (1917), 46 (1919), 55 (1917).
Kristina Holmin Verdozzis family archive (photo): 86, 88, 270.
Mendeleev, Dimitri Ivanovich: 20 (photo) 20, 21 (ill., 1871), 25.
Micke Asklander's collection, Tommy Gjerling (photo): 215.
Peter Tunön: 91.
Research Match Sweden AB (photo of Claes Fahlander): 131.
Sven Erlander (photo, 1923): 69.
Sven Gösta Nilssons family archive (photo): 213.
Sven Johanssons family archive (photo): 134, 149.
TASCA (photo of Dirk Rudolph): 131.
Ulf Litzén, archive (photo of Ulf Litzén): 93.
Ulf Uhlhorns photo archive (photo of Ulf Uhlhorn): 239.

Suppliers of photographs / illustrations

AB Lagrelius & Westphal, Nobel foundation (photo, 1922): 28, 44.
ACTRIS: 158, 159 (bild a).
Allhems Förlag, Erik Liljeroth, *Lund i Bild*: 5.
Akademiska Hus: 400.
American Physical Society: 101, 201 (photo, 1963).
Andrzej Szlagor (ill.): 243, 378, 381, 383, 385, 396.
Annika Nyberg (photo, 2011): 9, 13 (photo, 2011), 15, 23, 473,
477-487, 492, 494-496.
Antoniah (photo, 2008): 185.
Arbetarrörelsens archive & library, Hernried:
66, 78 (photo of Tage Erlander and Torsten Gustafson, 1955).
Arvid Leide, *Department of physics, Lund University* (book 1968):
8, 35 (house plan), 12, 449.
AT&T Bell Laboratories (1974): 280
Atomic Physics Division, photo archive (photo): 476.
Barbro Forkman: 375, 466.
Bastian Holst (fig, 2005): 384.
Beck & Ljung (artwork): 178.
Bilder i Syd AB: 103-104 (photo of Sten von Friesen), 463.
Blekinge Museum (photo): 426-428, 431-432, 434.
Britta Kleen (design drawing, 1994): Cover, IV-V, 475.
Brookhaven National Laboratory (BNL): 336.
CALIPSO, NASA (bild a): 163.
Carl Peter Mörth, u.å. (portrait of Daniel Menlös): Cover, 4.
Cecilia Jarlsskog: 229.
CERN: 309 (ill., 1992), 313, 319, 323-325 (fig.), 335 (ill.).

- CERN/Scanpix: 338.
C Laplante: 443.
Daniel Jacobsson, Lund University: 292.
Department of physics, LU: 1, 8, 13, 16-17, 32, 43, 45, 93, 98-99, 103,105, 118-119, 125-127, 129, 133, 140, 144, 146, 171-172, 197-198, 205-206, 212, 218, 220, 223, 225, 282, 286-287, 290, 311 (bild), 317, 354, 362-363, 377, 382 (Mikael Eriksson, P O Nilsson), 386, 397-398.
Department of Physics, Uppsala University (portrait): 58.
DESY, Hamburg: 329.
E Berrocal (2008): 419.
École polytechnique picture collection.
(photo of Alfred-Marie Liénard): 393.
Elna Heimdal Nilsson: 409, 421.
Erik Liljeroth (photo): 147, 240, 448 (photo of Gerd Risberg).
ESA: 500a.
Fergus of Greenock (ill of JC Maxwell): 393.
Fysik- & Laser Show photo archive: 470-471.
Gaspar Schott (copperplate): 456-457.
Georg E Schröder (portrait of Märten Triewald, 1740): 3.
GN Flerov: 209.
Henrik Bladh: 411, 418, 423, 476.
Hermann Grimmeiss (1977): 279.
HG Berry: 346.
ICPS (1986): 289.
Imperial War Museums, Brooks, Ernest, picture collection. 1900-61 (1915): 40.
Ivan Maximov: 236, 302, 476.
Jacques-Louis David (painting, 1788): 410.
Jan Pallon (photo, 2010): 145.
Jiajian Zho: 425.
Johan Sjöholm: 420.
Johan Zetterberg: 412.
Knut and Alice Wallenberg's Foundation, Magnus Bergström: 498.
Krigsarkivet, Stockholm, Dahlberg, Erik.
Historical posters (nr 20.21, 1976): 2.
Kristianstad Airshow (2006): 79.
Kristian Storm (The hall effect, transistors): 307.
Kulturen in Lund: 439-440, 444 (painting, 1791);
Viveca Ohlsson (photo): 446.
Landskrona museum: 50, 51 (photo of Enoch Thulin),
52 (photo, 1919).
Leide, Göran (photo): 10-11, 14, 85 (photo archive, 1953), 92.
Len Sirman Press: 312.
Leonard Roos af Hjelmsäter, *Esaias tegnér, Samlade skrifter* bd.1 (ill., 1816): 445.
Ligo: 499.
Lisa Larsson (ceramic model): 208.
Lufthansa, Udo Kröner: 160.
Lund Institute of Technology, archive: 216, 226, 235, 237, 284, 288, 307, 308, 414.
Lund University, archive: 153, 162, 175 (photo, 1977), 228, 314, 389, 404-407, 459, 472.
Lund University Historical Museum: 68.
Lund University Information Secretariat: 231, 234.
Lund University Library: 26, 76;

- Nils Schenmark, (drawings from Collegium curiosum): 3;
 Per Bagge (photo): 6, 7 (photo, 1928), 182.
 Malmö Museum Collections, Otto Ohm (1929): 233.
 Mandaworks: 455.
 Marcel van Helvoort: 303.
 Martin Magnusson (solar cells): 307.
 Mathematical Society, archive: 70 & 72 (1923);
 74 (photo of Aina & Tage Erlander).
 Mats Nygren: 488, 490.
 MAX IV Laboratory, archive: 125 (Ur-MAX), 241, 355, 388, 402;
 Annika Nyberg (photo): 47, 205, 208, 244, 384 (2007), 390, 399;
 FOJAB (ill.): 391;
 Perry Nordeng (air-photo): 245.
 M Björnmalm (bumper array): 308.
 Mikkel Brygdegaard: 424.
 MODIS, NASA (bild b): 163.
 NASA: 352, 356, 498.
 National Archives (1945): 78.
 National Portrait Gallery, London:
 Howard Coster (photo of James Chadwick, 1940): 117, 200;
 Stoneman, Walter (photo of Sir William Henry Bragg, 1920): 39.
 Nicke Johansson: 467.
 Nils Nyberg: 474 (photo, 2016).
 Nils Schenmark (1743): 442.
 NIST: 503b
 Nobel Foundation: 33, 34 (photo, 1924),
 36 (photo of Wilhelm Conrad Röntgen, 1900),
 38 (photo of Max von Laue, 1914),
 39 (photo of William Lawrence Bragg 1915),
 102 (photo of Cecil Frank Powell, 1950),
 117 (photo of Ernest Rutherford, 1908),
 117 (photo of Henri Becquerel, 1903),
 188 (photo of Richard Feynman, 1965),
 202 (photo of J Hans D Jensen, 1965),
 202 (photo of Maria Goeppert-Mayer, 1963),
 395 (photo of J Schwinger, 1965),
 327 (photo of M Gell-Mann, 1969),
 229 (photo of Cecilia Jarlskog, 1999).
 North Holland Press, Amsterdam, *Preludes in Theoretical Physics*
 (photo of Yoishiro Nambu, 1966): 327.
 NRFs photo archive (photo of Anders Flodström, 1986): 382.
 Pcharito: 114.
 Per-Erik Bengtsson: 416.
 Per Lindström: 82, 239 (photo Hellmuth Hertz, Herman
 Grimmeiss, Sven Johansson), 242, 286-387, 458.
 Pierre Gassendi (portrait of Tycho Brahe, 1954): 2.
 Portrait gallery from Östergötland, (photo of Anna-Clara Romanus-
 Alfvén, 1937): 448.
 Ragnar Hellborg, archive: 430, 434.
 Rahm (photo of Louise Petrén-Overton): 448.
 Robert Collin: 422.
 Robert Krewaldt's photo studio (image): 167.
 Royal Library (KB), E Brenner (copperplate, 1969): 441.
 Royal Institute of Technology, archive (foto of G Borelius): 53.
 Scanpix, press photo: 77.
 Science Source: 48.
 Solid State Physics Division, archive: 296-297, 301, 304-306.
 Solstrålen – sagostunds barnens tidning, Borelius, Gudmund,

(Teckning: *Tre röda äpplen*, 1907): 54.
Stockholm University (photo of Hans-Christen): 53.
Stockholm University, archive (photo of Erik Hultén): 62.
Studentlitteratur (2013): 203.
Sune Svanberg, archive: 364-365, 367-368.
Surrealsciencestuff.wordpress.com: 504.
Sven-Inge Möller (fuel-LIF): 422.
Swedish Portrait Archive (SPA): 59 (photo of Torsten Heurlinger),
8 (portrait of Karl Albert Victor Holmgren).
Sydsvenska Medical History Society, archive (1960): 234.
Takatoshi Ichikawa: 219.
Tandberg JG, Historical instruments in Lund,
(Kosmos 2: s196, 1922): 4.
Tekniska museets arkiv (photo): 136, 177, 206.
Teoretisk Fysiks arkiv: 330 (photo of Bo Andersson), 460.
Theodor Maiman (skiss, 1960): 359.
Torbjörn Sjöstrand: 339.
UCAR/NCAR/ High Altitude Observatory (photo: 1991): 89.
United States Army: 96.
United States Geological Survey (USGS): 328.
University of Liverpool, Liam Gaffney and Peter Butler (pic.): 116.

University of Pennsylvania Library, Edgar Fahs Smith Memorial
Collection, Department of Special Collections (photo of Robert
Wilhelm Bunsen and Gustav Robert Kirchhoff): 23.
Uppsala University, archive: 391.
Viatour, Luc (photo, 1999): 83, 84.
Wærnberg, Jan, s. 30 (Historiska Media) *Enoch Thulin, Forskare,
flygare, företagare* (photo of Janne Rydberg): Cover, 18-19, 31.
Walfrid Ekman (1905): 184.
Wikipedia: 500b, 502, 503b.

Some of the images and graphs in this book, there have been difficulties to derive the source of copyright to. We regret this, and in the case of claims, please contact us. The book is not published for commercial purposes.

List of persons

A

Ahlström, Alfred Severin 42
Akselsson, Roland 140, 152
Aldén, Marcus 365, 413-414, 416
Alfvén, Hannes 448
Alinder, Erik 118
Almblad, Carl-Olof 253-254, 257, 261,
 264-265, 271
Alvarez, Luis 124
Alwinsson, Rune 380
Alzheimer 341
Anderberg, Bengt 390
Andersen, Jesper 399, 403
Andersen, Ole Krogh 256, 258
Andersson, Bo 330-331, 336, 339
Andersson Erlander, Aina 69-70, 72, 74,
 82, 285
Andersson, AE 9
Andersson, Lars 282
Andersson, Elvir 118
Andersson-Engels, Stefan 369
Andrade, Osvalde 362
Aristoteles 442
Arrhenius, Svante 63
Aryasetiawan, Ferdi 268-269
Ashcroft, Niel 256
Ask, Lars 282
Asp, Benny 469

B

Bardeen, John 256, 280

Bardyszewski, Witold 257
Baym, Gordon 256
Becquerel, Henri 117
Belin, Inga 253
Bengtsson, Hans Uno 331, 339, 460, 468
Bengtsson, Per-Erik 416
Bengtsson, Ragnar 222
Bengtsson, Tord 225
Benner, Mats IX, 479, 482, 484, 486
Berg, Roger 369
Bergengren, Johan 47, 56-58
Berggren, Tore 226-227
Bergsten, Margareta 253
Bergqvist, Ingvar 120
Berzelius, Jöns Jacob 17, 286, 302
Besedin, Vasilij 436
Bexell, Göran 478, 484, 487
Björklund, Gunnar 282
Blewett, JP 395
Bockasten, Kjell 362-363
Bohr, Aage 32, 203, 206, 211, 215
Bohr, Niels 28, 32, 40, 44-46, 61, 64, 73,
 78, 81, 169, 171, 199, 203, 216
Bojs, Gunnel 190, 195
Boleu, Reginald 212
Bondorf, Jakob 108
Borelius, Gudmund 53-54, 58, 280
Born, Max 201
Bose 274, 501-502
Bragg, Sir William Henry 39
Bragg, William Lawrence 39

Brabe, Tycho 2, 145, 472
Brattain, Walter 280
Braun, Stellan 283
Brout, Robert 501
Bunsen, Robert Wilhelm 23, 416
Burström, Hans 174
Bäcklund, Albert Viktor 184

C

Carlsson, Gillis 228
Cartesius 442
Cederholm, Olle 242
Cederkäll, Joakim 131
Cederlund, Jan 118
Chadwick, Ernest James 117, 200
Cheng, Hung 315
Claesson, Johan 212

D

Daguerre, Louis JM 446
Danielsson, Kristina IX
Darwin, Charles 472
Deppert, Knut 294, 488, 490
Dirac, Paul 188, 268-269
Dobovisek, Bibijana 118

E

Edlén, Bengt 10, 17, 77, 83-84, 86-99, 286,
 344-345, 351, 362
Edlén, Elfriede 14
Edler, Inge 175, 180

Edner, Hans 365-366
Ehrensward, Gösta 235
Einstein, Albert 35, 68, 110, 168, 171, 201,
274, 359, 394, 451, 464,
472, 501-503

Ejder, Erland 282

Ekberg, Jan Olof 348

Ekelund, AW 6, 446

Ekman, Walfrid 59, 181-184

Englert, François 501

Eriksson, Mikael 242, 382, 386, 388, 390,
400, 448

Erlander, Tage 66-70, 72, 74-75, 77-79
82, 285

Esaki, Leo 256

F

Fablander, Claes 131

Faxe, Helena 7

Feynman, Richard 188, 248, 272, 321

Flerov, Georgii N 209

Flodström, Anders 382, 388, 397, 399-400

Forkman, Barbro 465

Forkman, Bengt VII, 118, 124-125,
241-242, 379-380,
386-387, 474

Forkman, Ylva IX

Forsberg, Ulrika 490

Franck, James 169, 171

Frank, Göran 156

Frankman, Hanna-Maria 154

Frauentorf 222

Frederick Wilhelm I 457

Friedrich, Walter 38

Frisch, Otto Robert 201

Fröman, Per-Olof 118

Fälldin, Torbjörn 429

G

Gallardo, Mario 362

Ganot, Adolphe 447

Gell-Mann, M 327, 329

Giaever, Ivar 256

Gislén, Lars 253

Gisselbrecht, Mathieu 408

Goepfert-Mayer, Maria 202

Gordon, Walter 65

Grimmeiss, Hermann 17, 239, 256, 281-283,
285-286, 289, 291

Grossmann, Günter 253, 266

Gunnarsson, Laura 258

Gushchin, Anatoly 437-438

Gustafson, Gösta IX, 330-331, 335, 339,
468

Gustafson, Johan 406

Gustafson, Karin 73-74, 82

Gustafson, Torsten 66-67, 69-74, 76-78,
80-82, 171, 184, 187,
199

Gustafsson, Christer 212

Gustafsson, Hans-Åke 113

Gustafsson, Ulf 373

H

Hagemann, GB 217

Hagström, Stig 285

Hahn, Otto 200-201

Halvardsson, Filip 453

Hamamoto, Ikuko 215-217

Hansen, Kurt 127, 242

Hansson, Hans-Christen 153-154, 157

Hansson, Lars 118, 242, 376

Hansson, Per Albin 75

Hartman, Henrik 355

Hedberg, Vincent 317

Hedin, Lars 246-261, 267

Hedin, Hillevi 256

Heisenberg, Werner Karl 191, 201

Hellborg, Ragnar 121, 122, 430, 434, 436

Hellgren, Maria 267

Hellstrand, Erik 118

Hertz, Ellen 166

Hertz, Gustav 166, 168-169, 171

Hertz, Hans 166

Hertz, Heinrich 166-167, 393

Hertz, Hellmuth 81, 118, 165-166, 168-
180, 239, 281

Herzberg, Gerhard 32

Hess, Victor Francis 101

Hessman, Dan 291

Heurlinger, Torsten 55, 59-62

Higgs, Peter 309-310, 319, 323, 325, 338,
340, 460, 500-501

Hjelt, Ingrid 253

Holmgren, Karl Albert Victor 8, 447
Holmin Verdozzi, Kristina VII, 15,
 473-474
Honeth, Peter 477, 482-483, 485, 487
Hubble, Edwin Powell 110, 352, 356
Hultén, Lamek 248
Hulthén, Erik 60, 62-63
Hulthén, Ingvar 254
Håkansson, Kjell 121
Högberg, Thure 413

I

Ingelman, Gunnar 331, 339
Ingvar, David 458
Irbäck, Anders 342
Isberg, Bengt 93
Isberg, Åke 118
Ivansson, Håkan 392

J

Jakobsson, Bo 108
Janeček, Petr 212
Jarlskog, Cecilia 189, 229-230, 464
Jarlskog, Göran 315, 318
Jensen, J Hans D 202
Jepsen, Ove 258
Johansson, Aina 149
Johansson, Jonas 369
Johansson, Lars 407
Johansson, Lars Gösta 242
Johansson, Lennart 93

Johansson, Sven AE 118, 125, 133-136,
 139-141, 143, 146-
 149, 152, 208, 239
Johansson, Sveneric 99, 351-352, 357
Johansson, Thomas B 140, 152, 212
Jönsson, Bodil 459
Jönsson, Göran 452
Jönsson, Kjell 118
Jönsson, Leif 315, 320

K

Karlsson, Ulf 399
Kaiserfeld, Thomas IX
Kastler, Alfred 32
Kaurannen, Peter 373
Kerst, Donald William 395
Key, Wilhelm 242
King Carl XVI Gustaf 388, 402
King Gustaf VI Adolf 10, 92
Kirchhoff, Gustav Robert 23
Kjällerström, Bengt 253-254
Klein, Oskar 63-65
Knipping, Paul 38
Knutsson, Johan 454
Koch, John 10, 344, 451
Kohn, Walter 256
Konnov, Alexander 421
Kristensson, Adam 159
Kristiansson, Krister 103-104, 118, 235
Kristianssons, Per 124
Kröll, Stefan 367

Kröger, Ronald 472
Källén, Gunnar 81, 181, 186-187,
 189-196, 330

L

L'Huillier, Anne 371, 374, 480, 484,
 486, 498
Lamm, Inger-Lena 237
Landauer, Rolf 276
Langreth, David C 266
Lannefors, Hans 154
Larsson, Erik 235
Larsson, Karin 495
Larsson, Lars-Åke 282
Larsson, Lisa 208
Larsson, Stig Erik 212, 225
Lavoisier, Antoine 410
Leander, Georg 225
Lehmann, Harry 193
Leide, Arvid 42
Leide, Göran 118
Lemaitre, Georges 110
Letokhov, Vladilen 357
Lewander, Märta 373
Lidén, Kurt 118, 376
Liénard, Alfred-Marie 393-394
Lindau, Ingolf 388, 401-402, 493
Lindfelt, Ulf 256-257
Lindgren, Lars Johan 242
Lindb, Axel 47, 58
Lindkvist, Birgit 104
Lindqvist, Birgit 118

Linke, Heiner 291
Litzén, Ulf VI, IX, 93, 349
Ljungberg, Bo 178
Luce, JV 229
Ludwig, Anna Bertha 37
Lundgren, Edvin 406
Lundin, Lennart 242
Lundquist, Osvald 450
Lundqvist, Bengt 255
Lundqvist, Stig 248-249, 251-252
Lundström, Ingemar 472
Lykke, Peter 2
Löfdabl, Stellan 253
Lönnblad, Leif 335, 339, 472

M

Madsen, Marianne 494
Magnusson, Carl Erik VI, 462
Maiman, Theodore 359
Martinsson, Bengt 145, 153, 156, 160
Martinsson, Indrek 99, 345, 347-348
Maxwell, James Clerk 167, 393
McKenna 423
Meitner, Lise 201
Mendeleev, Dimitri Ivanovich 20
Menlös, Daniel 3-4, 442-443, 457
Michelson, Albert Abraham 495
Mickelson, Sonja 93
Mikkelsen, Anders 407
Minnhagen, Lennart 239, 344, 451
Minnhagen, Petter 253

Monemar, Bo 282-283
Morales, Alvaro 257
Moseley, Henry 40-41, 44
Sir Mott, Nevill 256
Mottelson, Ben 32, 203, 206, 211, 215
Månsson, Bengt 253
Mårtensson, Nils 391
Möller, Eskil 118
Möller, Peter 212, 218

N

Nambu, Yoishiro 327, 329
Newton, Isaac 4, 22, 443, 445, 451
Nilsson, Annika 496-496
Nilsson, Bengt 213
Nilsson-Almqvist, Bo 336
Nilsson, Christer 121
Nilsson, David 213
Nilsson, G Alb 55
Nilsson, Ingrid 213
Nilsson, Kerstin 494
Nilsson, Mats 242
Nilsson, Per Olof 382, 398
Nilsson, Sven Bertil 212
Nilsson, Sven Gösta 81, 139, 197-199, 203-
-209, 211-213, 215-
-216, 218, 221, 237, 239
Nishina, Yoshio 65
Nordbring-Herz, Birgit 173
Nordeman, Martin 441
Norlind, Nils 118

Nyberg, Annika VI, 474
Nyberg, Emy 176
Nyholm, Ralf 399, 403

O

Odhner, Willgodt 91
Oblén, Gunnar 212, 467-468
Oblsson, Mattias 342
Olsson, Rune 282
Omling, Pär 288, 291, 481, 483-484
Oskarsson, Anders 115
Otterlund, Ingvar 112
Ottosson, Mats-Ola 282

P

Pallon, Jan 145
Pauli, Wolfgang 30, 32, 187-189, 502
Paulze, Marie Anne Pierette 410
Pedersen, AL 42
Pedrosa, Carlos 257
Pendrill, Ann-Marie 467
Persson Ekstedt, Lillemor 242
Persson, Anders 367, 370
Persson, Bo 242
Persson, Börje 118
Persson, Lars 240
Persson, Nils-Erik 241-242, 386
Persson, Uno 103, 118
Petrén-Overtton, Louise 448
Peterson, Carsten 330-331, 339-340
Petterson, Börje 118

Petterson, Thage G 285-286
Petterson, Ulf 335
Planck, Max 35, 250, 258, 260, 499-500
Pleijel, Åke 235
Powell, Cecil Frank 102
Prins Bertil 289

Q

Queen Ulrika Eleonora 5

R

Ragnarsson, Ingemar 212, 220-221, 228
Rayet, Georges 95
Rayleigh (3:e baron), Strutt, JW 419
Reimann, Stephanie 273-274
Riklund, Rolf 253
Risberg, Gerd 448
Ristinmaa Sörensen, Stacey 404
Ritz, Walter 29
Roldin, Pontus 164
Romanus-Alfvén, Anna-Clara 448
Rommel, Erwin 170
Roslund, Johnny 242
Round, Henry Joseph 281
Rudolph, Dirk 131-132
Rutherford, Ernest 117, 199
Ruuth, Henrik IX
Rydberg, Janne 16, 18-21, 24-32, 34-35,
 50-51, 53, 86, 92-93, 280,
 344, 363, 451
Ryde, Hans IX, 118, 129, 131, 211, 451

Ryde, Nils 451
Röntgen, William 36-37

S

Sabry, Afaf 193
Samuelson, Lars 283, 287-291, 293, 298,
 301, 493
Samuelsson, Peter 275-276
Sandblom, Philip 234-235
Schawlow, Artur 364
Schenmark, Nils 3, 442
Schindlmayr, Arno 259
Schmiedel, Stefan 496
Schmitz, Birger 124
Schnadt, Joachim 405
Shockley, William 280
Schott, George Adolphus 394
Schrieffer, Bob 256
Schröder, Bent 127-128
Schrödinger, Erwin 65
Schwinger, Julian Seymour 188, 395
Sheppard, Helen IV
Sidén, Lena-Kajsa 483, 485
Siegbahn, Kai 289, 403
Siegbahn, Manne 10, 33-36, 41-49, 53, 55-
 -56, 60, 64, 68, 77, 84,
 92-93, 118, 211, 142,
 344-345, 449-450
Silverberg, Lars 253
Sjöholm, Mikael 373
Sjölander, Alf 251

Sjöstrand, Torbjörn 331, 334, 339
Sköldbörn, Holger 118
Solvay, Ernest 192
Somesfalean, Gabriel 373
Sommerfeld, Arnold 45-46, 64
Spole, Anders 441
Starfelt, Nils 118, 120
Stefanucci, Gianluca 265
Stenlund, Evert 112, 336
Stenström, W 55
Stenström Eriksson, Kristina 123
Stiefler, Werner 242, 386
Stiernhielm, Georg 440, 446
Stigmark, Lennart 118, 239
Stjernquist, Nils 17, 286
Stobeus, Kilian 3
Strassmann, Fritz 200
Svanberg, Katarina 368
Svanberg, Sune 364-366, 368, 370, 413,
 488
Svantesson, Nils 118
Svenningsson, Birgitta 153, 157
Svensson, Bengt EY 253, 461, 468
Swietlicki, Erik 153, 157-158
Szymanski, Zdzisław 212
Söderberg, Bo 331
Söderström, Bengt 476, 482

T

Tandberg, J 55
Tegman, Pehr 444-445

Tegnér, Esaias 445
Tham, Carl 285
Thulin, Enoch 16, 50-52, 409, 415, 447
Thånell, Leif 241-242, 386
Tillman, Carl 372
Tomonaga, Sin-Itiro 188
Triewald, Märten 3-5, 442-443, 457

U

Uhlhorn, Ulf 239
Uhrberg, Roger 399

V

van de Graaff, Robert J 144, 172
Verdozzi, Claudio 264-265, 270-271
von Barth, Ulf 253-255, 257, 261, 264,
266-267
von Dardel, Guy 312, 314, 318, 379
von Dardel, Matilda 195
von Fraunhofer, Joseph 22
von Friesen, Marc Puig 264-265
von Friesen, Sten 103-104, 118-119, 129,
235, 311, 376-377, 458
von Guericke, Otto 4, 446, 457
von Klitzing, Klaus 289
von Laue, Max Theodore Felix 38
von Linné, Carl 472

W

Wacker, Andreas 277-278
Wahlström, Claes-Göran 367, 370

Waldeskog, Berndt 118
Wallenberg, Alice 144
Wallenberg, Knut 144
Warrant, Eric 472
Weinberg, Steven 196
Weisskopf, Victor 205
Wene, Clas Otto 139
Wernberg, Jan 50
Werner, Gustav 226
Wernholm, Olle 376-377, 381
Wilson, Charles TR 102-103
Wingren, Bengt-Erik 242
Wobble, Stellar 498
Wolf, Charles 95
Wu, Tai Tsun 315

Y

Yevic, David 257
Young, Thomas 22

Z

Zeeman, Pieter 296
Zernike, Frits 32
Zetterberg, Johan 469-470
Zetterberg, Per Olof 469-470
Zweig, G 327

Å

Åberg, Sven 215, 223-224
Åkesson, Torsten 314, 325, 492
Åström, Karl Johan 285

This book tells the story of the boy from Halmstad who became world famous, the high school teacher who made a pioneering discovery, the professor who bought his professorial position and an incredibly inventive ex-prisoner of war, together with many, many others who have left their mark on the development of physics in Lund.

Follow the developments in a series of narratives in words and pictures, from physics lectures in a mediaeval fencing hall to cutting edge research in a Nano-cathedral, on the advent of the laser in Lund, and how it came about that MAX grew up and became an international research facility on the outskirts of Lund.

Physics helps us understand nature on a fundamental level, while constantly giving rise to new questions. Which new discoveries and inventions will save lives on our planet?

Physics is more exciting than ever before!

