



LUND UNIVERSITY

Environmental aspects of coal mine drainage: a regional study of Moatize in Mozambique

Pondja, Estevao

2017

Document Version:

Publisher's PDF, also known as Version of record

[Link to publication](#)

Citation for published version (APA):

Pondja, E. (2017). *Environmental aspects of coal mine drainage: a regional study of Moatize in Mozambique*. [Doctoral Thesis (compilation), Lund University].

Total number of authors:

1

General rights

Unless other specific re-use rights are stated the following general rights apply:

Copyright and moral rights for the publications made accessible in the public portal are retained by the authors and/or other copyright owners and it is a condition of accessing publications that users recognise and abide by the legal requirements associated with these rights.

- Users may download and print one copy of any publication from the public portal for the purpose of private study or research.
- You may not further distribute the material or use it for any profit-making activity or commercial gain
- You may freely distribute the URL identifying the publication in the public portal

Read more about Creative commons licenses: <https://creativecommons.org/licenses/>

Take down policy

If you believe that this document breaches copyright please contact us providing details, and we will remove access to the work immediately and investigate your claim.

LUND UNIVERSITY

PO Box 117
221 00 Lund
+46 46-222 00 00

Environmental aspects of coal mine drainage: a regional study of Moatize in Mozambique

Estêvão Alberto Júnior Pondja



LUND
UNIVERSITY

DOCTORAL DISSERTATION

by due permission of the Faculty of Engineering, Lund University, Sweden.
To be defended at the Faculty of Engineering, V-building, John Ericssons väg 1,
Lund, room V:B on 2nd of June, 2017 at 10:15 a.m.

Faculty opponent
Prof. Dr. Martin Ragnar

Organization LUND UNIVERSITY Division of Water Resources Engineering Box 118 SE-22100 Lund, Sweden Author: Estêvão Alberto Júnior Pondja		Document name DOCTORAL THESIS	
		Date of issue 2017-06-02	
		Sponsoring organization: Swedish International Development Cooperation Agency - SIDA	
Title and subtitle: Environmental aspects of coal mine drainage: a regional study of Moatize in Mozambique			
Abstract Mozambique is one of the largest coal producers in Africa. Extraction of the coal is carried out in the Moatize district of the Tete province in the center of the country. A surface mining technique is used to extract the coal below ground level. During mining activities, sulfide minerals, which are commonly associated with coal, are exposed to oxygen and water, leading to the generation of acid mine drainage (AMD). AMD is high in acidity and has a high content of metals, metalloids and sulfate that can cause severe damage to the environment. Moatize is inside the lower Zambezi River basin, the pollution that occurs there due to mining activities constituting a risk both for public health and for the water resources. The standard guidelines in Mozambique for wastewater from coal mining are very weak, allowing the coal mining companies to pollute considerably. The prevention, containment and remediation of polluted mine water are measures that should be carried out to avoid the spread of pollution. Prevention is the least expensive strategy, but it cannot always prevent the generation of polluted mine water. Thus containment and treatment need to be put into practice. Both active and passive treatment are used to treat polluted mine water. Since Moatize is a largely unstudied area, both static and leaching tests were carried out to investigate the possibility of AMD being generated. The geochemical processes that could impact on the quality of mine drainage stemming from the waste rock there were assessed. Use of cost-effective methods for the treatment of mine water by use of bioremediation coupled with adsorption, using cassava peels that are readily available in the country as a carbon source and as an adsorbent is proposed. Since climate changes and climate variability can exacerbate the negative impact of surface mining, the possibility of this was assessed. It was found that the production of AMD was likely in at least one of the coal mines in Moatize. The mine water from coal mines in Moatize was found to have a high content of sulfate, calcium, magnesium and manganese. A set of guidelines for coal mine effluents that was developed, based on different guidelines obtained from around the world, was proposed for Mozambique. Sulfate reducing bacteria coupled with adsorption appeared to be appropriate for removing these pollutants. Cassava peels used as adsorbents appeared to be effective in removing calcium, magnesium and manganese. Based on climate data, the period from November on through February was found to be the period in which the pollution load in Moatize was greatest. Since the flow rate in the Revúbué River, which is close to the coal mines, is highly dependent upon the precipitation that occurs during the rainy season, the discharge of polluted mine water should be avoided. To achieve sustainable mining in Moatize, the coal mining companies, the regulators and the stakeholders from water sector there need to work together. A framework for integrating efforts to satisfy the needs of the different stakeholders involved in the water sector in Moatize was proposed.			
Key words: coal mining, acid mine drainage, mine water treatment, climate change, low-cost adsorbent			
Classification system and/or index terms (if any)			
Supplementary bibliographical information		Language: English	
ISSN and key title: 1101 – 9824		ISBN: 978-91-7753-289-7 (Print) 978-91-7753-290-3 (e- version)	
Recipient's notes	Number of pages		Price: -
	Security classification		

I, the undersigned, being the copyright owner of the abstract of the above-mentioned dissertation, hereby grant to all reference sources permission to publish and disseminate the abstract of the above-mentioned dissertation.

Signature _____ Date: 25 April 2017

Environmental aspects of coal mine drainage: a regional study of Moatize in Mozambique

Estêvão Alberto Júnior Pondja



LUND
UNIVERSITY

Coverphoto by Estêvão A. Jr. Pondja

Copyright Estêvão A. Jr. Pondja

Faculty of Engineering, Department of Building & Environmental Technology
Division of Water Resources

ISBN print: 978-91-7753-289-7
ISSN e-version: 978-91-7753-290-3

Printed in Sweden by Media-Tryck, Lund University
Lund 2017



I dedicate this thesis to my beloved mother Isabel Nhantumbo for having made me everything I am today. Now I understand what you mean when you said that education is a key that opens many doors. I thank you for your support, encouragement and your endless love.

Acknowledgements

I would like first to thank God for having given me the health and strength needed for my studies here in Lund. I would like to thank my supervisors Prof. Kenneth M. Persson and Nelson Matsinhe for all of the guidance and instructions that you have provided me with during my Master and PhD studies. I want to thank Prof. Rolf Larsson for helping me with various administrative issues that have developed since I arrived in Lund for the first time for Master studies until recently and for inviting me for a fantastic dinner in your house with your family. Thank you Prof. Magnus Persson for all the support in the laboratory you have given me and for the help that you provided me in reading through and correcting my second paper. I would like to thank Mohammad Alijaradin and Raed Bashitalshaaer for the support you have given me. Thank you Prof. Magnus Larson for being my contact person in accommodation matters at the Chemical Center. I also want to thank Johanna Sörensen for the paper that we wrote together, and in connection with which I learned a lot from you. My special thanks to all the professors from TVRL I have had contact with for all the knowledge you provided me. I would like to thank Sofia Mebrahtu Wisén from the Department of Biology of Lund University for helping me with regard to the analysis of mine water. I would like to thank Anki Wikander for providing me accommodations. I would like to thank all my colleagues from TVRL Clemêncio, Miguel, Dauren, Denis, Barbara, Cláudia, Carla, Angelica, Kamshat, Caroline, Björn, Dong, Yiheng, Kean, Jing, Erik, Almir and others. I would like to thank SIDA for the financial support they provided me during my Master and PhD studies in Lund. Finally I want to thank my wife Ezelina Bila, my mother Isabel Nhantumbo and my son Walden Pondja for all the love and support you have been giving me.

Popular summary

During the last decade, multinational mining companies started to exploit coal in the Moatize district in the central province of Tete in Mozambique. Geologists discovered there what is considered to be the largest unexploited coal deposit on earth, one that contains about 23 billion tonnes of coal. Surface mining has been used there to extract the coal. During mining activities, solid, liquid and gaseous wastes are produced. The wastes of greatest concern are liquid wastes in the form of polluted mine water, generally acidic in character, containing toxic metals in large amounts. If such acidic mine water with a high content of toxic metals, its also being known as acid mine drainage is released to the environment, it can damage the environment and presents a risk to public health. Moatize is located within the lower Zambezi River basin, which is the largest and most important one in the country, due to its potential for agriculture, hydropower production, fishing, drinking water supply and tourism. Climate change can exacerbate the negative impacts of mining and, since the Zambezi River basin is vulnerable to climate change, it is of vital importance to protect the basin insofar as possible from the effects of mining pollution and climate change.

The standard guideline applying to the disposition of wastewater from coal mines in Mozambique is weak, its allowing polluted mine water to be discharged into the local water resources. Due to the weakness of this standard guideline for dealing with coal mine wastewater, various multinational mining companies have made use of the South African guidelines instead.

The aim of the present study was to investigate the various impacts of coal mines on the local environment in Moatize and to assess the possibilities of remediation of the polluted coal mine water there. In addition, the impact of climate change on the coal mine water in Moatize was assessed.

Standard guidelines from many different countries concerning coal mine wastewater and drinking water were investigated in efforts to propose a better guideline than the present one for use and disposal of the coal mine wastewater in Mozambique. The coal mine drainage there was assessed by use of leaching tests to determine whether there is a possibility of acid mine drainage being generated in Moatize. The impact of climate change on mining activities was also analyzed on the basis of climate data. A cost-effective method that was developed for the treatment of polluted mine water was investigated.

The coal mine drainage in Moatize was found to be basically neutral and to have a high content of calcium, magnesium, manganese and sulfate. At least one of the coal mines there was found to be likely to produce acid mine drainage. Bioremediation coupled with adsorption making use of cassava peels that are readily available in the area serving as a carbon source for bacteria and as an adsorbent was found to be a good solution for the treatment of mine water in Moatize, various metals, as well as sulfate and cassava peels (agricultural waste) can all serve as treatment. Based on the climate data, the period from November on through February was found to have the greatest pollution load. The flow in the Revúbué River, which is one of the main tributaries of Zambezi River in Moatize, is directly dependent upon the precipitation that occurs during the rainy season. Coal mining companies also should avoid discharging polluted mine water there. A guideline for coal mine wastewater in Mozambique was proposed, one that was based on international guidelines. A framework for the achievement of sustainable mining was proposed one in which regulators (government/representatives), mining industries and other stakeholders concerned with matter of water use in the lower Zambezi River basin would work together closely.

Abstract

Mozambique is one of the largest coal producers in Africa. Extraction of the coal is carried out in the Moatize district of the Tete province in the center of the country. A surface mining technique is used to extract the coal below ground level. During mining activities, sulfide minerals, which are commonly associated with coal, are exposed to oxygen and water, leading to the generation of acid mine drainage (AMD). AMD is high in acidity and has a high content of metals, metalloids and sulfate that can cause severe damage to the environment. Moatize is inside the lower Zambezi River basin, the pollution that occurs there due to mining activities constituting a risk both for public health and for the water resources. The standard guidelines in Mozambique for wastewater from coal mining are very weak, allowing the coal mining companies to pollute considerably. The prevention, containment and remediation of polluted mine water are measures that should be carried out to avoid the spread of pollution. Prevention is the least expensive strategy, but it cannot always prevent the generation of polluted mine water. Thus containment and treatment need to be put into practice. Both active and passive treatment are used to treat polluted mine water. Since Moatize is a largely unstudied area, both static and leaching tests were carried out to investigate the possibility of AMD being generated. The geochemical processes that could impact on the quality of mine drainage stemming from the waste rock there were assessed. Use of cost-effective methods for the treatment of mine water by use of bioremediation coupled with adsorption, using cassava peels that are readily available in the country as a carbon source and as an adsorbent is proposed. Since climate changes and climate variability can exacerbate the negative impact of surface mining, the possibility of this was assessed. It was found that the production of AMD was likely in at least one of the coal mines in Moatize. The mine water from coal mines in Moatize was found to have a high content of sulfate, calcium, magnesium and manganese. A set of guidelines for coal mine effluents that was developed, based on different guidelines obtained from around the world, was proposed for Mozambique. Sulfate reducing bacteria coupled with adsorption appeared to be appropriate for removing these pollutants. Cassava peels used as adsorbents appeared to be effective in removing calcium, magnesium and manganese. Based on climate data, the period from November on through February was found to be the period in which the pollution load in Moatize was greatest. Since the flow rate in the Revúbué River, which is close to the coal mines, is highly dependent upon the precipitation that

occurs during the rainy season, the discharge of polluted mine water should be avoided. To achieve sustainable mining in Moatize, the coal mining companies, the regulators and the stakeholders from water sector there need to work together. A framework for integrating efforts to satisfy the needs of the different stakeholders involved in the water sector in Moatize was proposed.

Papers

Appended papers

The present thesis is based on the following papers which were referred to by their roman numbers in the body of the text. The papers are attached at the end of the thesis.

- I. **Pondja Jr., E.**, Persson, K. and Matsinhe, N. (2014). A Survey of Experience Gained from the Treatment of Coal Mine Wastewater. *Journal of Water Resource and Protection*, **6**, 1646-1658. doi: [10.4236/jwarp.2014.618148](https://doi.org/10.4236/jwarp.2014.618148).
- II. **Pondja, E.A.**, Persson, K.M. & Matsinhe, N.P. (2017). Assessment of coal mine water in Moatize by static and leaching tests. *Sustain. Water Resour. Manag.* (2017). doi:10.1007/s40899-017-0106-7
- III. **Pondja, E.A.**, Persson, K.M. & Matsinhe, N.P. (2017). An assessment of coal mine drainage in Moatize using multivariate statistics. *Sustain. Water Resour. Manag.* (Submitted).
- IV. **Pondja Jr., E.**, Persson, K. and Matsinhe, N. (2017). The Potential Use of Cassava Peel for Treatment of Mine Water in Mozambique. *Journal of Environmental Protection*, **8**, 277-289. doi: [10.4236/jep.2017.83021](https://doi.org/10.4236/jep.2017.83021).
- V. **Pondja, E.A.**, Persson, K.M. & Matsinhe, N.P. (2017). Treatment of coal mine water in Mozambique using low-cost cassava peels as an adsorbent. *Cogent Environmental Science* (submitted).
- VI. **Pondja, E.A.**, Persson, K.M. & Matsinhe, N.P. (2017). Impact of coal mining, exacerbated by climate change, on water resources in Moatize. *Water, Air & Soil Pollution* (submitted).

Author's contribution to the appended papers

- I. The author planned the study together with the co-authors, carried out the literature review and was the main contributor to the writing of all sections and of the discussion and the final review of the paper.
- II. The author planned and performed the study and the laboratory tests with assistance of the co-authors. The author was the main contributor to the writing of all sections and for the finally review of the paper.
- III. The author planned the study together with the co-authors, performed the statistical analysis and was the main contributor in the writing and discussions of the paper with assistance of the co-authors.
- IV. The author planned the study together with the co-authors, carried out the literature review and was the main contributor to the writing of all sections and of the discussion and the final review of the paper.
- V. The author planned and performed the study and the laboratory tests with the assistance of the co-authors. The author was the main contributor to the writing of all sections and for the finally review of the paper.
- VI. The author planned together with the co-authors the study, carried out statistical analysis of the climate data together with the co-authors, the author was the main contributor to the writing of all section and of the discussion of the final version.

Other related publications

Conference paper

Pondja Jr., E., Persson, K. and Matsinhe, N. (2016). Proposal of standard guideline for effluent water in coal mine in Mozambique. *International Journal of Management and Applied Science (IJMAS)*, 2, special issue 1, 28 – 33. Doi: IJMAS-IRAJ-DOI-3873.

Abbreviations

AMD – Acid mine drainage

AP – Acid potential

ARA – Regional Water Administration

BOD – Biological oxygen demand

COD – Chemical oxygen demand

CRA – Water Supply Regulation Council

DO – Dissolved oxygen

FIPAG – Water Supply Investment and Assets Fund

HDS – High density sludge

INE – National Institute of Statistics of Mozambique

LDS – Low density sludge

M – Coal mine “M” in Moatize

MINAG – Ministry of Agriculture

MISAU – Ministry of Health

MITADER – Ministry of Land, Environment and Rural Development

MOPHRH – Ministry of Public Work, Habitation and Water Resources

NNP – Net neutralizing potential

NP – Neutralizing potential

NPR – Neutralizing potential ratio

R – Coal mine “R” in Moatize

R_L – Separation factor

SAPS – Successive alkalinity-producing systems

SRB – Sulfate reducing bacteria

SSF – Simultaneous saccharification and fermentation

TDS – Total dissolved solids

TSS – Total suspended solids

Content

1. Introduction	1
1.1 Objectives	2
2. Theoretical background	3
2.1 The study area	4
2.2 The coal mine production	6
2.2 The impact of mine water on the environment	10
2.3 Environmental legislation concerning coal mine water in Mozambique	11
3. Materials and methods	14
3.1 A review of literature concerning different mine water treatment methods	14
3.2 Field work	14
3.3 Laboratory analysis	15
3.4 Data source	15
3.5 Statistical analysis	15
4. Results and discussion	17
5. Limitation of the study	36
6. Conclusions and future outlook	37
References	40

1.Introduction

The mining industry is one of the most highly polluting industries in the world. Water resources are the main target of mining pollution. Pollutants from mining industries have the potential of destroying the environment, their representing a risk to public health. Communities located around mining areas are at great risk if appropriate measures to avoid pollution are not undertaken. In developing countries, due to the lack of experts in mining areas there as well as for economic reasons this risk is higher than it is in developed countries. Climate change is another factor that exacerbates the negative impact of mining. It is of vital importance to have well-functioning mine water management in order to protect both people and the environment. That can be achieved by the mining industries, the regulators and the stakeholders involved working together at this (Soni & Wolkersdorfer, 2015).

“Mining is the extraction of material from the ground in order to recover one or more components parts of the mined material” (Lottermoser, 2010). Mining plays an important role in the world’s economy. Mining products are used in many different sectors, such as in the construction and the manufacturing sectors, and the energy and the agricultural sectors (regarding fertilizers in the latter case). Since both the world’s population and the demand for a better quality of life are increasing the production and consumption of minerals will also increase (SME, 2008). With the increase in the production of minerals the mine waste and mine water produced will also increase. Generally speaking the mining industry produces huge amounts of wastes that are in need of special attention (Adibee, et al., 2013).

Countries such as Australia, Canada, Brazil, South Africa and the United States have a long history of mining. There are many abandoned mines in those countries that continue to cause environmental problems, presenting a risk to public health and having negative socio-economic impact in the lives of people in the local communities involved (Naidoo, 2017). The rehabilitation of abandoned mines requires large monetary investments its not being clear who should pay for the rehabilitation of these abandoned mines. In many countries, the costs of restoring the negative legacy of these mines are carried by the government (Mhlongo & Amponsah-Dacosta, 2015). Since the governments of many developing countries do not have sufficient funds, however, to pay for the rehabilitation of these mines, the prevention of pollution and a reduction in the total fresh water consumption by such mines should be given high priority.

Mozambique is located in southeastern part of Africa, its economy being highly dependent upon agriculture. During the last decade, coal deposits were discovered in the Moatize district in the center of the country, these attracting many multinational mining companies. Since Moatize is inside of the lower Zambezi River basin, pollution due to mining activities presents a risk to the local environment. The environmental legislation concerning mining wastewater in Mozambique is still deficient, its allowing the mining companies there to pollute. Africa is highly vulnerable to climate change, the water resources of such internationally shared river basins as that of the Zambezi River having the potential risk of creating conflicts between the countries that share it (IPCC, 2001). Poverty, illiteracy, corruption, pollution and climate change are factors that can all contribute to destruction of the biodiversity of the lower Zambezi River basin. According to Soni & Workersdorfer (2015), all the stakeholders should be involved in mine water management, the approach to best take being a bottom-up rather than a top-down (Soni & Wolkersdorfer, 2015).

1.1 Objectives

The basic objective of the present dissertation was to investigate the various impacts of coal mines on the local environment in Moatize and to investigate possibilities for the remediation of the polluted coal mine water there. In addition, the impact of climate change on the coal mine water in Moatize was assessed.

The more specific objectives of the dissertation were as follows:

- To identify and describe methods for the treatment of polluted mine water and to discuss how to select an appropriate treatment for a specific mine site (Paper I);
- To investigate the possibility of acid mine drainage being generated in Moatize (Paper II);
- To investigate the geochemical processes that impact upon coal mine drainage in Moatize, using multivariate statistical analysis (Paper III);
- To propose a cost-effective method for treating mine water in Moatize (Paper IV);
- To evaluate the use of a low-cost adsorbent for the treatment of coal mine water in Moatize (Paper V);
- To analyze changes in coal mining pollution that are due to climate change and to propose a framework for sustainable mining in Moatize (Paper VI).

2. Theoretical background

Mozambique is located in the southeastern part of Africa, its having a total surface area of 799,380 Km². It has a total population of about 26 million people and a growth rate of about 2.7 % per year. The GDP growth rate is about 6.6 % and the population density is about 32.2 inhabitant/Km² (INE, 2015). The climate is of a tropical rain savannah type, the mean average temperature being about 26°C (Matsinhe, 2008).

According to the National Directorate of Water, there are 104 river basins in Mozambique, 13 of which are large ones. The amount of water produced inside the larger basins is approximately 216.5 km³ (DNA, 1999). The Zambezi River basin is the largest and is also one of the most important river basins in the country, due to its potential for agriculture, fishing, the production of electricity and the supply of drinking water. The availability of water in Mozambique is considered to be good in comparison with neighboring countries, although the water demand was expected to increase from 636 million m³ (in 2000) to 918 million m³ (in 2015), due to the increase of the number of water users, population growth being the main factor here (Bank, 2005). The total population of the country is expected to increase from 23 million (in 2012) to 49 million (in 2050), leading to an increase in the water demand. The total amount of water that was withdrawn in the country in the year 2000 was estimated to be 635 million m³, 87% (550 million m³) of which was expected to be for agriculture, 11% (70 million m³) for use in the municipal sector and 2% (15 million m³) for use in the industrial sector. For the agricultural sector, the water demand increased to 900 million m³ in 2015 (NEPAD, 2013). At the time of the estimates (year 2000), multinational coal mining companies were not yet operating in the country. The water consumption by the multinational mining companies, the environmental pollution due to mining, and the climate change taking place in the Zambezi River basin will limit the water availability considerably if necessary countermeasures are not carried out.

Coal mining in Mozambique increased considerably during the last decade due to the discovery there of one of the largest unexploited coal deposits on earth, which is now being exploited by the following multinational mining companies: Vale (Brazil), Rio Tinto (Australia and the United Kingdom), Beacon Hill Resources (United Kingdom), Ncondezi (United Kingdom), Minas de Revúboé (UK and USA), Jindal Steel Power (India), and Estima (ENRC – Eurasian Natural Resource

Corporation). Since 2011, when the first multinational coal mining company (Vale) began to mine coal in Mozambique, coal production has increased a great deal, as shown in Fig. 1.

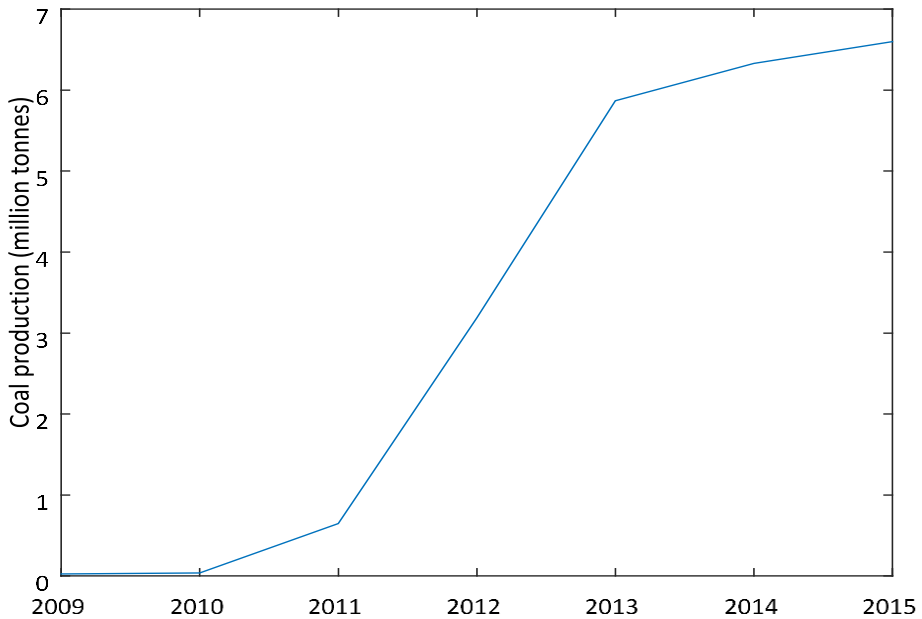

Figure 1. Coal production in Mozambique from 2009 to 2015 (INE, 2015).

2.1 The study area

Moatize is a district located in the Tete province in the center of Mozambique (see Fig. 2). It has a total surface area of about 8,455 km² and a population density of 13.4 inhabitant/km². The climate is semi-arid and sub-tropical, there being an annual mean precipitation of 644 mm/year and a potential evapotranspiration of 1,644 mm/year. The minimum and the maximum average annual temperature levels are 21 and 33°C, respectively (José & Sampaio, 2011). The Moatize-Minjova coal basin consists of interbedded carbonaceous, mudstones, sandstones and coal seams, its being the only one that is under exploitation at the moment (Fernandes, et al., 2015). This study area was selected because of its being potentially sensitive to pollution due to mining, through its being inside of the lower Zambezi River basin, which contains many small tributaries that pass through different mining sections, their

thus representing a risk for public health and for the environment. It is important to note that the interactions that occur between water resources and mining activities are site-specific and complex, their having potential impacts on the water quality and the hydrology during all stages of the life of a mine (Northey, et al., 2016).

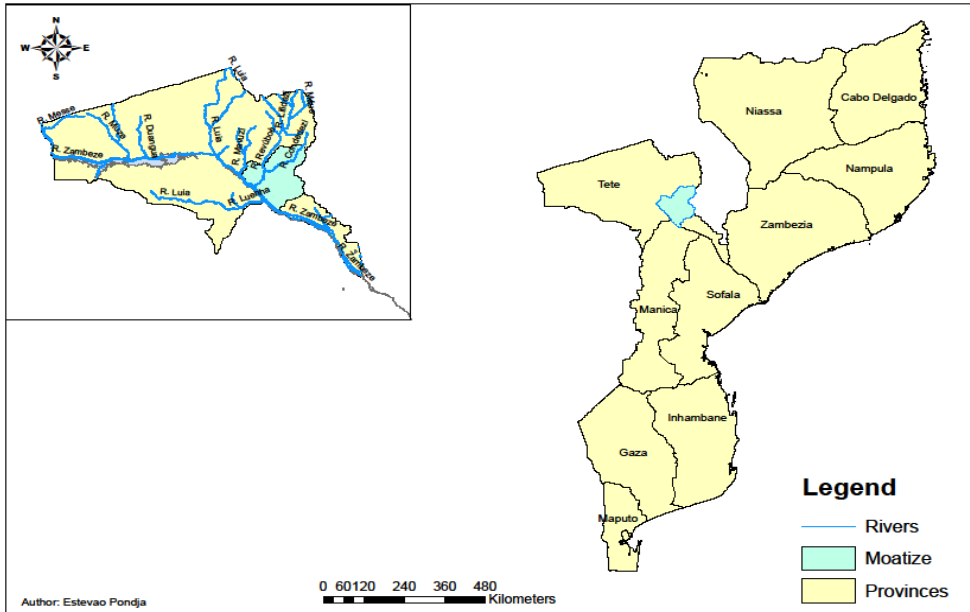

Figure 2. A map of Mozambique and of the Tete province upper left showing Moatize and various tributaries of the Zambezi River.

The geology of the study area is presented in the Fig. 3 below. The coal mines are located in areas in which argillite, sandstones and coal seams are found. Limestone is found in areas outside of the mining areas that are under exploitation. In Fig. 3 one can see that other minerals such as iron, copper, uranium and gold are likewise found, inside of Moatize. The planned exploitation of iron in Moatize is in an advanced stage of investigation. Some of the tributaries of the Zambezi River pass through the coal mining area and can transport pollutants to the Zambezi River (Fig. 3). The occurrence of iron, gold and copper in the study area means that it is likely that metal mining companies will come and exploit them, thus leading to an increase in the risk of environmental pollution there.

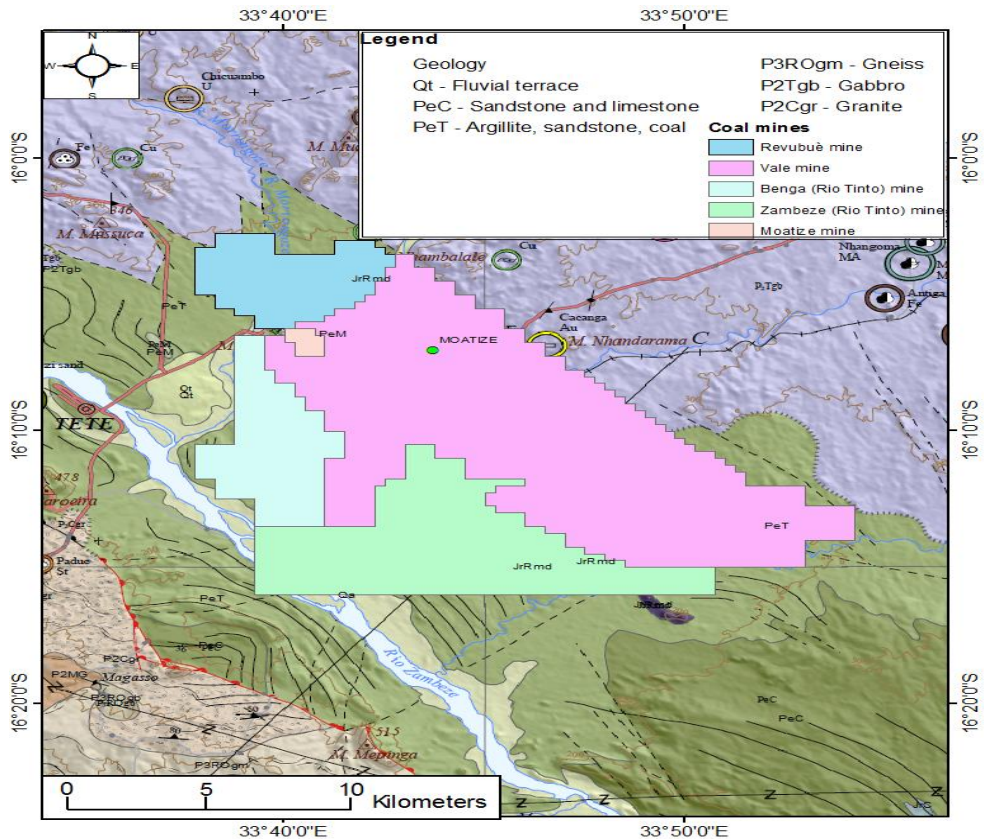

Figure 3. The Geology of Moatize in the Tete province of Mozambique.

2.2 The coal mine production

The first step in coal mine production is the extraction of coal from the ground. This activity can be carried out in the form of either surface or underground mining. In Moatize only surface mining is conducted, in the present study its thus being only surface mining that is discussed. Surface mining is the process of the extraction of coal or ore in an area that is open to the sky. It starts with excavation to remove whatever overburden is present (stripping of the overburden). The next step is mining of the coal or ore. What comes finally then is restoration or abandonment of the mine void. Based on how these three activities are undertaken, surface mining

can be classified as being either open pit mining, opencast mining (strip mining) or hydraulic mining (Hartman, 1987). The coal mining companies operating in Moatize carry out open pit mining and opencast mining.

After being mined, the coal is sent to a beneficiation process in which the quality of the coal is improved through removing gangue mineral and reducing the ash content. During this process, a waste stream which is referred to as tailings is generated (Fig. 4). According to Lottermoser (2010), there are two types of mine wastes: waste rock (spoil of a grain size $\gg 1$ mm) and tailings (of a grain size < 1 mm). The waste rock that is not backfilled is deposited in a waste rock pile (spoil heap). Revegetation of waste rock piles can be carried out to restore the environment. The disposal of tailings is carried out in a tailing pond (or tailing storage facility, referred to as tailing dam) (Lottermoser, 2010). As shown in red in Fig. 4, the waste rock and the tailings are the main source of acid mine drainage (AMD).

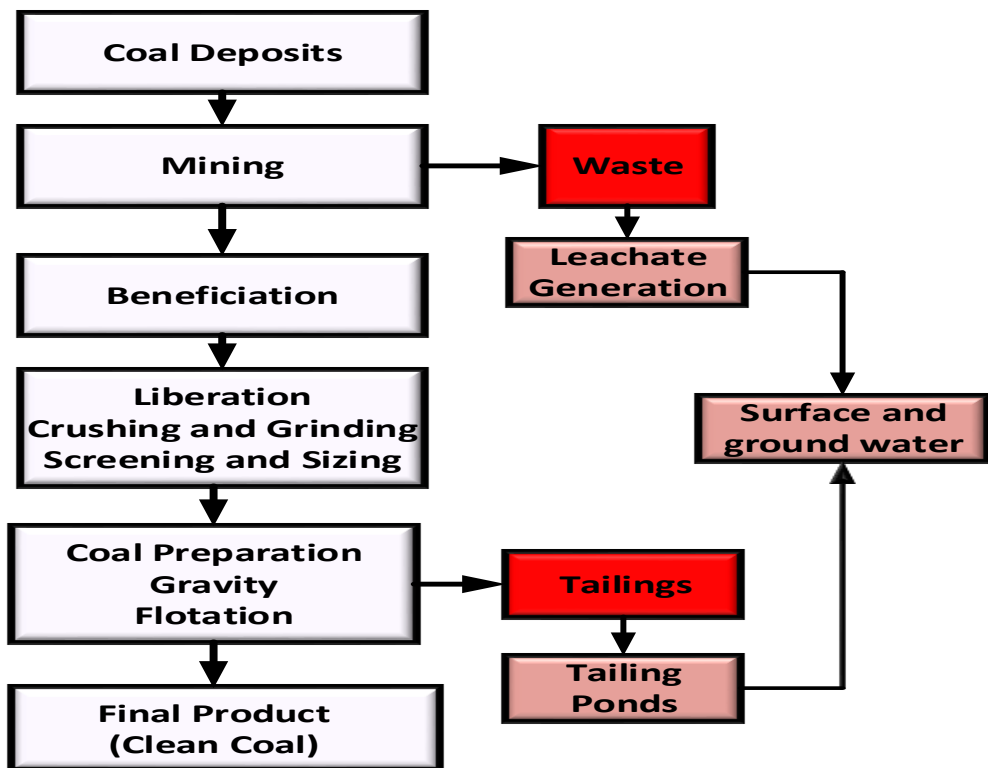

Figure 4. Coal mine production and the generation of mine wastes. Adapted from (SME, 2008) and (Jain & Das, 2017).

The management of tailings is a very challenging and risky task, since failures of tailing dams caused by bad handling of the tailings and extreme weather events (floods) have led to serious environmental disasters in various parts of the world (Rico, et al., 2008). Tailing dams are built of mine waste instead of concrete, a fact that can lead to erosion or the seepage of mine water (Schoenberger, 2016).

The total amount of mine water produced by all the coal mines in Moatize as a whole from the years 2009 to 2015 is shown in Fig. 5. The amounts of mine water generated in the Moatize coal mines were estimated based on the coal production that occurred and the generation of mine water in the case of VALE coal mining company. It was assumed that the other coal mines had basically the same characteristics as these of VALE. Although this is not in fact the case, due to a lack of data it was not possible to use true data from all of the coal mines. Since the total amount of coal produced by the coal mines in their entirety is known, and is reported in the statistical yearbook published by INE (Instituto Nacional de Estatística), reasonable calculations were carried out. The mine water generated in Moatize is increasing because production in the mines is also increasing, yet less than 50% of the mine water is recycled.

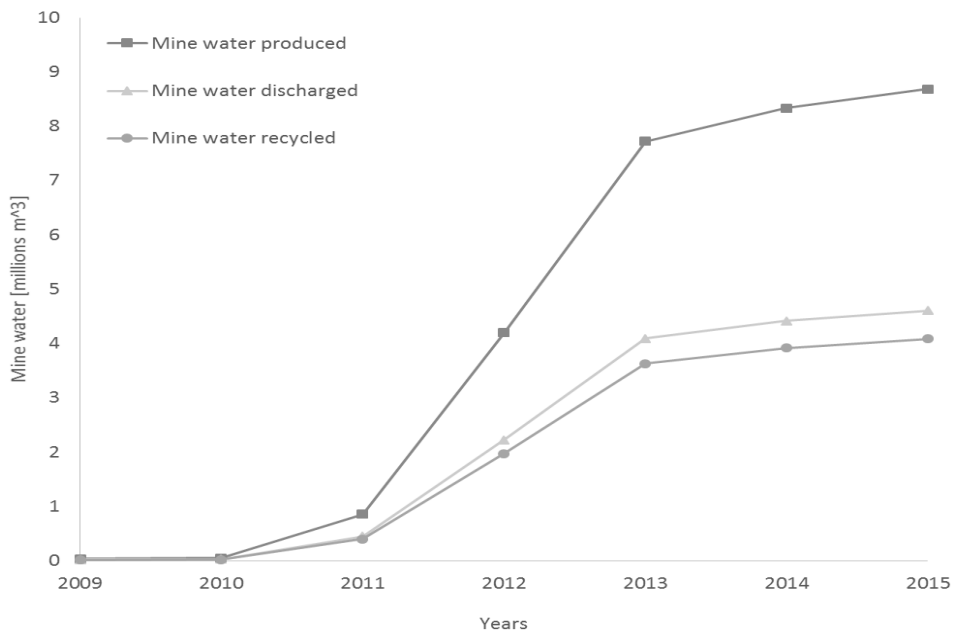
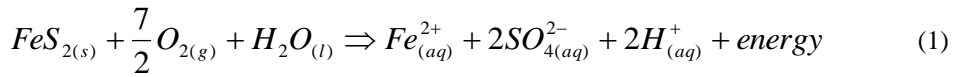
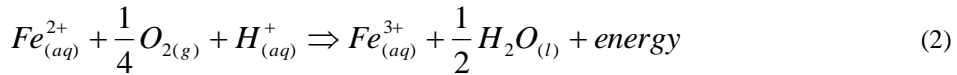

Figure 5. The use of water by coal mines in Moatize (VALE, 2015) and (INE, 2015).

The main products resulting from the coal mining in Mozambique are thermal coal for producing electricity and cooking coal used for the production of steel. During the production of cooking and thermal coal, solid waste, dust and polluted mine water are produced, AMD being the most serious environmental problem involved here. The process of AMD generation is complex. Sulfide mineral present in the rock or tailings can be oxidized when they come into contact with oxygen and water. Pyrite is the most abundant sulfide mineral, and since it is commonly associated with coal or ore, it will be used to illustrate how AMD is generated. The process of the weathering of pyrite is described here in detail in Eqs. 1- 4 and is summarized then in a single equation (Eq. 5). When pyrite is exposed to oxygen and water, it oxidizes and form dissolved ferrous iron, sulfate and hydrogen ions (Eq. 1) (Lottermoser, 2010):



The ferrous iron produced, shown in Eq. 1, is oxidized by oxygen to form ferric iron (Eq. 2). This reaction occurs at low pH (less than 3).



The ferric iron produced oxidizes additional pyrite to form ferrous iron, sulfate and hydrogen ions (Eq.3).

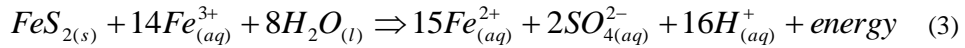

With an increase in pH to approximately 3, due to partial neutralization with carbonates, the reaction shown below (Eq. 4) occurs. Dissolved ferric iron precipitates and further acidity is thus produced. This means that the availability of ferric ions is affected by the pH. In the neutral or alkaline mine water the solubility of ferric iron is very low.

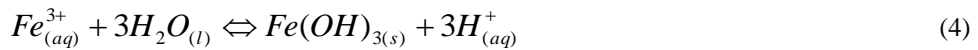

The process of pyrite oxidation is summarized by Eq. 5.

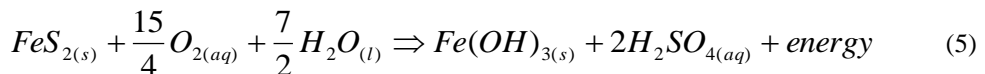

The process of AMD production generally involves 5 components. The first component is air (oxygen). The second component is iron provided by a sulfide mineral (e.g pyrite). The third component is sulfur coming from sulfide, sulfate ions, and organic compounds. The fourth component is water and the fifth component is bacteria that are present. Acidithiobacillus ferrooxidans and leptospirellea can increase the reaction rate of oxidation of sulfide by Fe^{3+} up to six to eight times (SME, 2008). The bacteria involved generally accelerate the production of AMD. The relationship between these components can be represented in the acid mine drainage tetrahedron shown in Fig. 6.

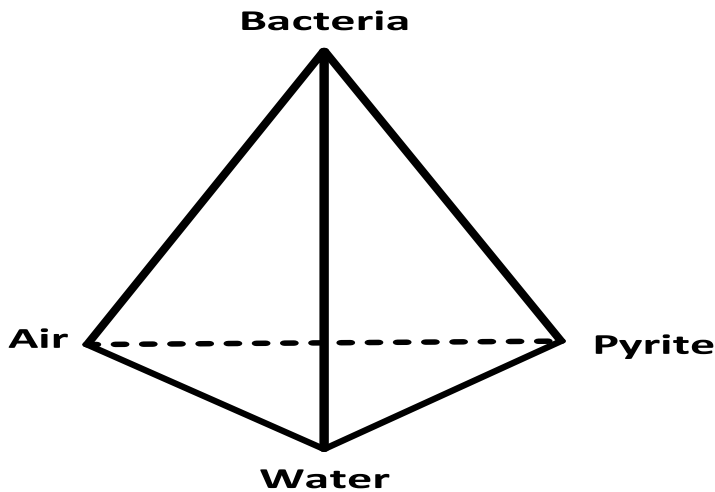

Figure 6. A tetrahedron of acid drainage (SME, 2008).

2.2 The impact of mine water on the environment

If the neutralizing minerals present in the rock are not sufficient to neutralize the acidic water produced by sulfide oxidation, AMD is released to the environment. AMD of low pH and high metal content can lead to the death of fish and other aquatic species. The main product of pyrite oxidation is iron hydroxide, which can precipitate in rivers, giving the water a reddish/yellowish color (see Fig.7). A considerable length of time is needed to solve the threat that AMD poses for the environment. It cannot be solved by a single intervention (Simate & Ndlovu, 2014).



Figure 7. The impact of AMD in the municipality of Criciuma in Brazil.

2.3 Environmental legislation concerning coal mine water in Mozambique

The standard guideline for wastewater discharge in the coal mines of Mozambique is presented in Table 1. This guideline is very weak since it does not include pollutants of relevance that can damage the environment. The concentration of mercury presented in the guideline is very high in comparison with other international guidelines (Pondja, et al., 2015). The coal mining companies in Moatize use this guideline, and other mining companies there use South African guidelines due to the weakness of it (Pondja, et al., 2015).

Table 1. The guideline used for coal mine water in Mozambique. The unit for each of the parameters is mg/L, except for the pH values (Assembleia da República, 2004).

Parameter	Value
pH	6 - 9
TSS	35 – 50
Oil and fat	10
Mercury	3.5

In a study carried out by Pondja et al (2015), drinking water guidelines from different countries and mine water guidelines from international institutions were

combined in order to propose a strong guideline for the coal mine wastewater in Mozambique. Both Table 2 and Table 3 present the proposed guidelines, most of the parameters that are relevant for mine water pollution being included there. The guideline proposed in Table 2 is for mine water and surface run-off. Mine water is considered to be the water coming from underground locations, its quality and quantity depending upon the local rock mass and location of the water table, respectively. The surface run-off water comes from surface water run-off during raining that occurs (Dharmappa, et al., 1995).

Table 2. A proposed guideline for coal mine water and for surface run-off in Mozambique as expressed in mg/L (Pondja, et al., 2015).

Pollutants	Maximum permissible value
pH	6 - 9
TDS	300
TSS	70
COD	150
BOD ₅	50
Oil and grease	10
SO ₄ ²⁻	250
As	0.1
Cd	0.05
Cr	0.1
Cu	0.3
CN	1.0
Fe (total)	2.0
Pb	0.2
Hg	0.02
Ni	0.5
Zn	0.5
Mn	2.0
Al	0.2

The proposed guideline for process wastewater pertaining to coal mining in Mozambique is presented in Table 3. The process wastewater is considered to be water that comes from the coal washing plant, the cleaning of equipment, oil storage and the coal conveyor (Dharmappa, et al., 1995).

Table 3. The proposed guideline for process wastewater that comes from the coal washing plant in Mozambique (Pondja, et al., 2015).

Pollutants	Maximum permissible value
pH	6 - 9
BOD ₅	30.0
COD	150 (40 cooling water)
NH ₄ ⁺ as nitrogen	5.0
Total nitrogen	10.0
Total phosphorus	2.0
Sulfide	1.0
SO ₄ ²⁻	250.0
Oil and grease	10.0
TDS	300.0
TSS	35.0
Total metals	10.0
Cd	0.1
Cr (total)	0.5
Cr (hexavalent)	0.1
Cu	0.5
Co	0.5
Zn	1.0
Pb	0.5
Fe	3.0
Ni	1.0
Hg	0.02
V	1.0
Mn	2.0
Phenol	0.5
CN	0.5
Al	0.2

3. Materials and methods

The present thesis was based on a review of literature concerning different methods used for the treatment of mine water, together with field work, laboratory analysis and data collection from different sources.

3.1 A review of literature concerning different mine water treatment methods

A literature review (paper I) was conducted to identify and describe different methods used for the treatment of polluted mine water. Since the treatment methods suitable for a mine water of a particular type are site-specific, a review of the procedures one needs to take in order to choose the most appropriate methods was carried out. Investigation of the possibility of using a low-cost adsorbent for the treatment of wastewater contaminated by metals was likewise carried out (paper IV).

3.2 Field work

A considerable amount of field work in the study area was performed. Different coal mining companies were visited to determine how they operated. ARA-Zambezi, which is responsible for water management in the Zambezi River basin, was also visited. Seminars in which persons working for different coal mining companies, as well as various stakeholders, met to discuss the risks associated with mining in the study area took place. Most of the coal mining companies did not allow us to conduct research on their property. Only two coal mining companies permitted us to collect samples and to conduct research. At the request of the coal mines in question the names of the coal mines involved are not mentioned in connection with the results we reported. Mine water was collected from different pits and was sent to a laboratory for analysis. Waste rock samples were collected in the study area so as to perform static and kinetic tests on them. Local markets in Maputo were visited to buy fresh cassava for treatment of the coal mine water.

3.3 Laboratory analysis

The methods used to assess the weathering of waste rock were static and leaching tests (paper II). These involved the collection of samples from both coal mines M and R. Three techniques were employed for the static tests involved, namely a paste pH test, standard acid base accounting (ABA) and modified ABA. A fizz test was used to rate the reaction rate between waste rock and acid (HCl) in order to determine the volume and the concentration of the acid that needed to be added in the static test. Both the neutralizing potential (NP) and the acid potential (AP) were determined. The net neutralizing potential (NNP) and the neutralizing potential ratio (NPR) were used to assess whether or not the waste rock was an acid-producing material. The leaching test was performed in 4 Buchner funnels at 33°C and use of a one-week cycle was implemented. The leaching water was collected once a week and was sent to a laboratory for analysis of the ion concentrations involved.

The synthetic mine water used in the adsorption process (Paper V) was produced from a leaching column filled with waste rock material. Deionized water was recirculated in the column at a flow rate of 1.5 L/h for 72 hours by use of a peristaltic pump. Cassava peels that had been dried in the sun for 7 days, been chopped and milled and finally been activated by 0.3 M of nitric acid were used as an adsorbent. The adsorption process was performed in a water bath shaker at 30°C at a rotation speed of 150 rpm. The mine water both before and after the adsorption process had taken place was sent to a laboratory for analysis of the metal concentration (paper V).

3.4 Data source

Data from different institutions were used in conducting the present investigations. Data series concerning the rainfall and the temperature of Moatize were provided by the National Institute of Meteorology of Mozambique (INAM), the flow rate of the river in the Zambezi River basin and in Revúbué being provided by ARA-Zambezi. The National Institute of Statistics of Mozambique (INE) provided data concerning coal production in Mozambique (paper VI).

3.5 Statistical analysis

Multivariate statistical analysis was used to investigate the geochemical processes that impacted on the mine water leaching from waste rock in Moatize. The physical-

chemical parameters of water obtained during leaching tests were normalized and Person correlation matrix was used to obtain the principal components. The correlation coefficients of 14 parameter together with the principal components were used to assess the geochemical processes that impacted on the mine water leaching in a waste rock dump in Moatize (paper III).

A frequency analysis of the accumulated precipitation that occurred during the rainy season for the period of 1953 to 2015 was performed. Based on a normal distribution, the return periods for different monthly average precipitation levels that could occurs during the rainy season were determined. A box plot was used to analyze the precipitation variability and to identify outliers for the rainy season (paper VI).

4. Results and discussion

From the literature review it was found that the treatment of mine water can be classified in terms of two categories: active treatment and passive treatment (Chowdhury, et al., 2015). The objective of active treatment is to remove pollutants from mine water, making use of both physical (through use of filters or membranes) and chemical processes. In order to keep the treatment process running, the supplying of energy, together with chemical addition and human intervention, are required (Wolkersdorfer, 2008). The most widely used active treatment are those of low density sludge (LDS) and of high density sludge (HDS), both of these including mine water oxidation, the addition of an alkaline material (caustic lime, sodium hydroxide or limestone) and finally removal of the sludge produced. There are other treatment methods too, such as ion exchange, reverse osmosis, ozone oxidation, membrane filtration, bioremediation using sulfate reducing bacteria and electrocoagulation that are also made use of (Nariyan, et al., 2017). A summary of the different active treatment methods, together with the advantages and disadvantages of each are presented in Table 4.

Table 4. Summary of active treatment of mine water (Paper I).

Treatment method	Suitable for removing	Advantages	Disadvantages	Reference
Aeration	Fe ²⁺ and Mn	Low operation cost, releases CO ₂ from mine water, increases DO	Not effective for water of low Fe ²⁺ content	(Kirby, et al., 2009)
High-density sludge process	Fe ²⁺ , Fe ³⁺ , Al, Mn, Cu, Zn, Pb and SO ₄ ²⁻	Generation of low volumes of sludge, high water recovery, low lime costs, scaling control, can treat large flows of AMD, sludge recycling	Limited sulfate removal, generation of sludge	(Kuyucak, 2006)
Limestone/lime neutralization	Fe and Al	Low alkali costs, sludge recycling	Limited sulfate removal, generation of sludge	(Geldenhuis, et al., 2003)
Membrane filtration	Brackish and saline mine water	Good quality of water that is treated, high degree of water recovery	Scaling, fouling, requires pretreatment and post-treatment, sludge and brine production and short membrane life	(Magdziorz & Sewerynsky, 2000)
Biological sulfate removal	Sulfate and Fe	Highly effective in removing sulfates	Best for water at pH > 5, the effluent metal concentration obtained may exceed permissible limits	(EPA, 2006)

Passive treatment methods are methods that consume little or no chemicals, require no use of electrical energy and in which human intervention (maintenance) in the treatment process is very rare. The best known methods of this sort are aerobic and anaerobic wetlands, anoxic limestone drains, vertical flow systems (also called SAPS) and open limestone channels. A summary of different passive methods, and the advantages and disadvantages related to each, are shown in Table 5.

Table 5. A summary of passive methods for the treatment of mine water (Paper I).

Treatment method	Suitable for removing	Advantages	Disadvantages	Reference
Open limestone channels	Pre-treatment or post-treatment	Low operating and maintenance costs, no power consumption, can last for many years, simple and reliable	Coating, a long channel required to achieve the retention time desired	(Trumm, 2010)
Aerobic wetlands	Acid water containing Fe, Mn and SS	Low operating and maintenance costs, no power consumption, can last for many years	Cannot treat strongly acidic water effectively (best for pH>5.5)	(Hedin, et al., 1994)
Anaerobic wetlands	Acid water of low DO, Al, Fe ³⁺ and SS content	Low operating and maintenance costs, no power consumption, can last for many years	Coating on a limestone surface due to the presence of Fe and Al, a large area and long retention time needed to remove Mn.	(Hedin, et al., 1994)
Anoxic limestone drains	Acid water of low Al and Fe ³⁺ content	Low operating and maintenance costs, no power consumption, can last for many years, simple	Requires pretreatment, best for acidic water with low DO, Al and Fe ³⁺ to avoid armoring	(Zipper, et al., 2011)
Successive alkalinity-producing systems (SAPS)	Acid water of high metal content (Fe, Al, Zn, Cu)	Low operating and maintenance costs, no power consumption, can last for many years	Metal floc accumulation and degradation of the organic layer, pretreatment required for acidic water with high Fe ³⁺ and SS contents	(Zipper, et al., 2011)

To select the most appropriate treatment method for a specific mine, a feasibility study needs to be performed. During such a study, effectiveness (the potential of a certain method to achieve the remedial goals that have been established), implementability (the ability of the method in question to comply with the technical and administrative issues involved) and cost (the least expensive method is normally chosen) are evaluated.

According to Wolkersdorfer & Kleinmann (2011), regardless of the treatment method chosen, it is necessary to perform a thorough investigation of the mine water chemistry and of the mass balance since insufficient knowledge of the mine water chemistry, the flow and of how both vary over time can lead to failures during treatment operations. It was necessary in order to suggest a suitable treatment method for Moatize, to investigate the water quality situation, to assess whether AMD can be generated and to study the geochemical processes that impact upon the mine water quality in Moatize.

The results of static tests for both coal mine M and R are presented in Table 6. The standard and the modified methods for coal mine M indicate that the generation of AMD is unlikely there since $NNP > 20 \text{ kgCaCO}_3/\text{tonne}$, yet the paste pH test indicates there to be a pH value of 6, which means that no conclusion can be drawn on the basis of the paste pH. The NPR for the same coal mine is between 2 and 4, meaning that AMD is not to be expected. The standard and the modified methods for coal mine R fall within the uncertainty zone ($-20 \text{ kgCaCO}_3/\text{tonne} < NNP < 20 \text{ kgCaCO}_3/\text{tonne}$), meaning that no conclusion can be drawn on the basis of either method. The paste pH has a value of 7.5, meaning that neutralizing material is present. The NPR method yields values of less than 1.0, meaning that the waste rock sample from coal mine R can be considered to be acid-producing. Since there is so much uncertainty, it is necessary to also evaluate the results of the kinetic test (the leaching test).

Table 6. The static test results for coal mines M and R, respectively (AP, NP and NNP are expressed in $\text{CaCO}_3/\text{tonne}$) (Paper II).

Sample	NP	AP	NNP	NPR	Paste pH
Standard method					
M	133.33	34.38	98.95	3.88	6.0
R	6.25	21.56	- 15.31	0.29	7.5
Modified method					
M	82.5	30.75	51.75	2.68	6.0
R	9.87	21.03	- 11.16	0.47	7.5

Table 7 presents the results for the mine water that was collected in the pits both of coal mine M and coal mine R in Moatize. In Table 7 it can be seen that the coal mine water is neutral and has a high sulfate, calcium and magnesium content. During collection of the samples, most of the pits in coal mine R were dry. Comparing the sulfate concentration and the TDS value given in the proposed guideline (see Table 2) with the values presented in Table 7, it can be seen that the values in Table 7 exceed the permissible limits that are proposed in Table 2.

Table 7. Results of the mine water compositions obtained in the different pits in Moatize (Paper II).

Elements	Samples			
	M1	M2	M3	R1
Al (mg/l)	0	0	0	0.028
Ca (mg/l)	331	119	430	338
Fe (mg/l)	0.131	0.057	0.042	0.046
Mg (mg/l)	240	242	407	498
Mn (mg/l)	0	0	0.003	1.4
Ni (mg/l)	0.001	0	0	0.017
S (mg/l)	943	620	1156	1141
Ti (mg/l)	0.0003	0	0	0
Zn (mg/l)	0.001	0	0.001	0.057
SO ₄ ²⁻ (mg/l)	3154	2028	3812	3594
pH	8.2	8.5	8.1	7.7
Conductivity (µS/cm)	8.4	6.7	11.9	13.7
Alkalinity (mmol/l)	3.8	4.2	2.4	3.1

A leaching test was performed during a period of 11 weeks, the detailed results obtained being presented in Paper II. On the basis of the leaching test results obtained, it was found that the concentrations of sulfate, calcium, magnesium and manganese are very high as compared with the proposed guidelines. The pH values for both of the coal mine waters was between 7.1 and 7.8. The cumulative rate of sulfate increase in each of the two samples presented in Fig. 8. Comparing rates of increase in sulfate in the two coal mines, it can be seen that the oxidation rate is higher in coal mine M than in coal mine R. The content of total dissolved solids (TDS) in both coal mines is very high. Water with a high TDS level is low in quality, the cost associated with human consumption of it and for agricultural and industrial use of it being high (Sarver & Cox, 2013). According to Server & Cox, water sectors that use large amounts of water are faced with an increase in the direct costs involved in the loading of TDS, the domestic sector being the sector that pays the highest amount here, since for human consumption the water quality needs to be very high.

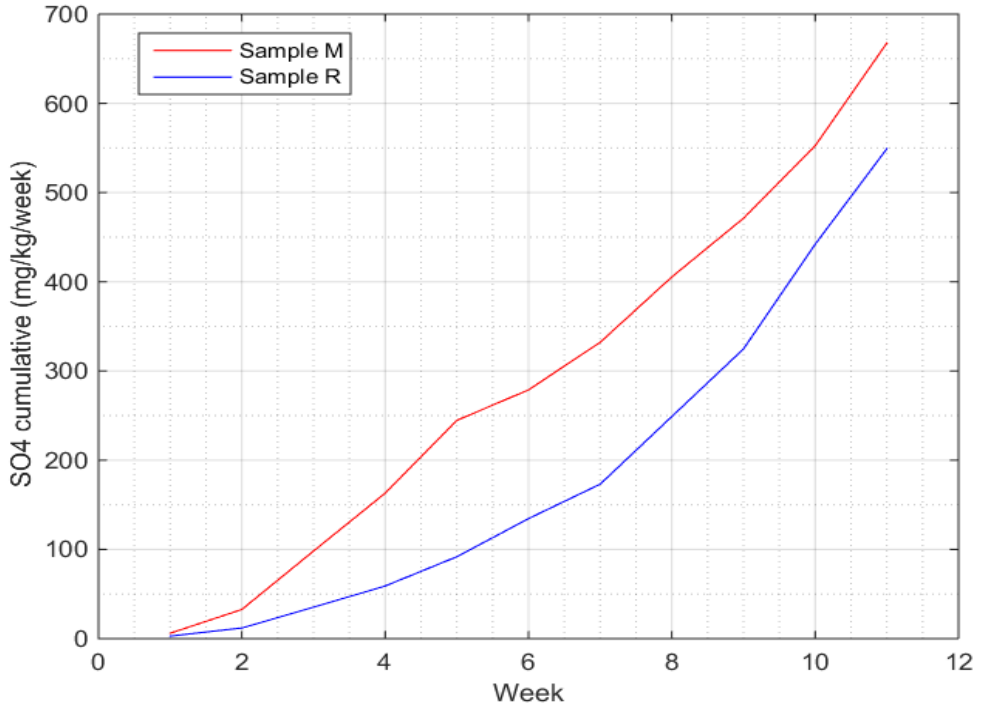

Figure 8. The cumulative sulfate found to be present in the course of the leaching test.

The percentages of sulfur and of carbonates that are weathered over time for each of the two coal mines are presented in Figs. 9 and 10. From Fig. 9 it can be seen that in the beginning the weathering rate of the carbonates is higher, but that it starts to decrease from week 4 on. This means that the sulfur will sooner or later become exhausted, the carbonates alone remaining then, making the generation of AMD unlikely. In Fig. 10 the situation is completely different, since there the rate of weathering of the carbonates is high compared with the rate of weathering of the sulfur. This means that in the future the carbonates there will become used up, the sulfur alone remaining, making the generation of AMD rather likely. The marked disadvantages of a leaching test being carried out in a column situated in a laboratory is the fact that it fails to take account of the climatic conditions that are presented in the mine area (Fox, et al., 2015).

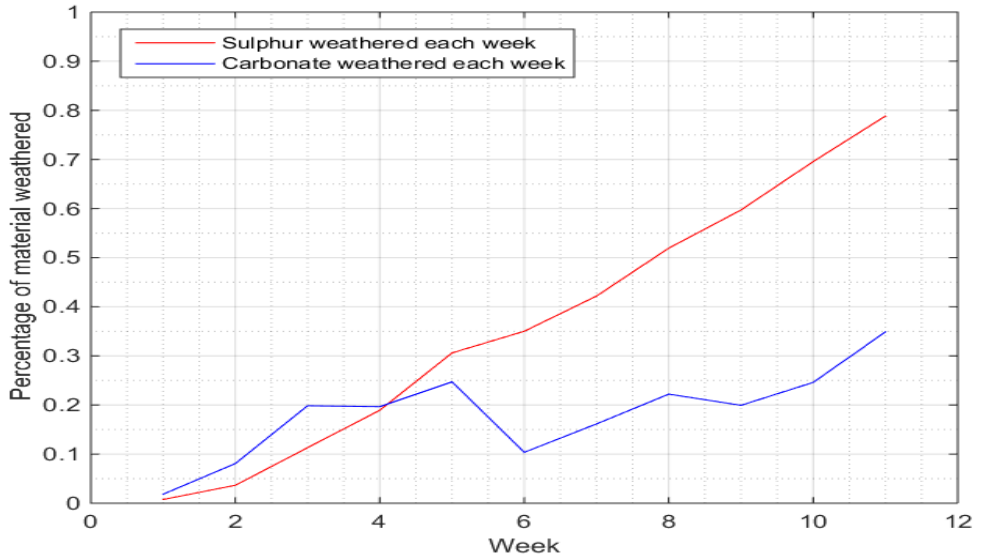

Figure 9. The percentage for sample M of sulfur and carbonates that are weathered during the leaching test.

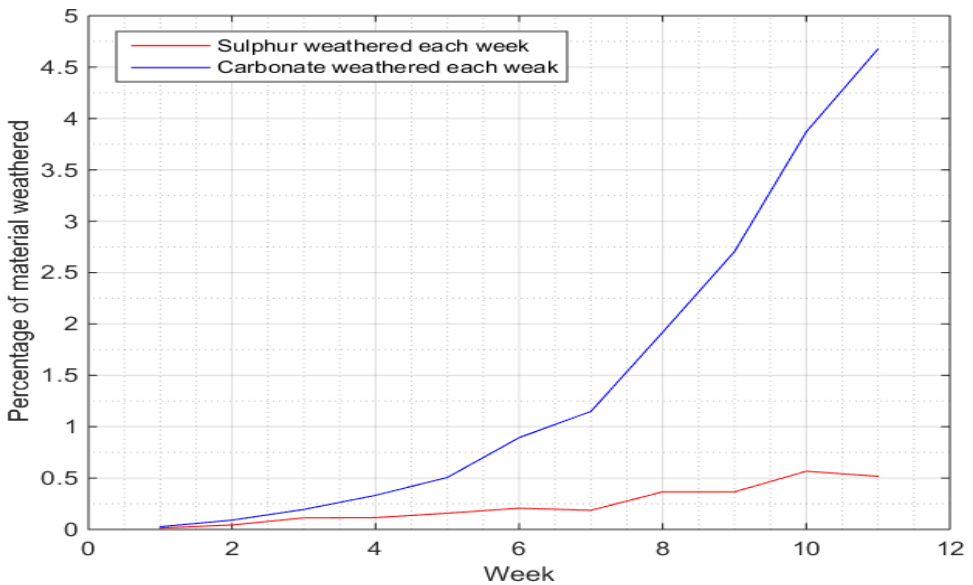
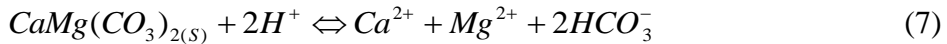
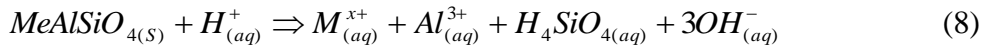

Figure 10. The percentage for sample R of sulfur and carbonates that are weathered during the leaching test.

In the multivariate statistical analysis (Paper III) that was carried out it was found that the main geochemical processes that impact upon the mine water quality generated from coal waste rock in both of the coal mines in Moatize are those involving the neutralization of the acidic water by both carbonates and silicates, the oxidation of sulfide minerals and the precipitation of Fe^{3+} and Al^{3+} . The neutralization of acidic water by carbonates (calcite and dolomite) are shown in Eqs. 6 and 7.



The neutralization of acid water by silicates is shown in Eq. 8 (congruent weathering) and in Eq. 9 (incongruent weathering).



where Me = Ca, Na, K, Mg, Mn or Fe.

In Eq. 8 one can note that the weathering of silicates releases OH^- ions, thus increasing the alkalinity.

As Eq. 9 shows, the silicate that incongruent weathering produces is solid and it also precipitates, thus removing Al^{3+} from the solution. The concentration of the Al^{3+} in the solution decreases then, due to the precipitation of $Al_2Si_2O_5$, at the same time as the concentration of metals (Ca^{2+} , Mg^{2+} , Mn^{2+} , Na^+) in the solution increases, this leading to a rise in TDS. It has been found that in Appalachian coal mines in the United States TDS is the major stressor of aquatic life, due to the mine water that is discharged there having high TDS content (Daniels, et al., 2014).

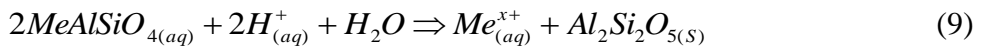

Many studies have shown that lignocellulose biomass, which consists of cellulose, hemicellulose, lignin and proteins, can be used as an adsorbent for removing ions from wastewater (Pinto, et al. 2016; Wang, et al. 2009; Farajzadeh & Monji 2004; Nadagouda, et al. 2011; Laszlo & Dintzis 1994). Cassava peels are a biomass of this type. Since Mozambique produces large amounts of cassava peels, it was proposed here that one use cassava peels for bioremediation together with adsorption in the treatment of mine water in Moatize. The advantage of bioremediation (the use of SRB) here is the fact that it is low in cost and that it can also remove metals and

sulfates at the same time. The treatment of mine water with SRB involves the removal of acidity, of metals and metalloids, and of sulfate. The metals that precipitate with the sludge can be recovered. The principles upon which this method is based are the following: organic matter (CH₂O) is used as a carbon source (as an electron donor) by the bacteria involved so as to reduce the sulfate (as an electron acceptor) available in the mine water to hydrogen sulfide and create a state of alkalinity under anaerobic conditions (Eq. 10). The hydrogen sulfide produced reacts then with the metals to form metal sulfides, which are low in solubility and can be removed together with the sludge (Eq. 11). The SRB prefer compounds of low molecular weight (such as lactate, acetate, ethanol, and methanol) as carbon sources for sulfidogenesis (Liamlean & Annachhatre 2007; Steed et al. 2000; Webb et al. 1998; Tsukamoto & Miller 1999).

Since mine water has a low content of organic matter, cassava peels can be used to produce ethanol that can be used then as carbon source. One of the advantages of using ethanol as carbon source is that it can easily be converted by SRB. Using SRB for treatment of mine water has the advantage of its removing three different types of pollutants i.e sulfate, metals and agro-wastes (cassava peels) at the same time (Hussain, et al., 2016).



Where, M²⁺ are metals: Cu²⁺, Zn²⁺, Fe²⁺, Pb²⁺, Ni²⁺, Co²⁺, Cd²⁺, or Ag⁺

In Fig. 11, a cost-effective method for the treatment of mine water in Moatize that is proposed is presented. The process involved starts with the production of steam, using treated mine water and either thermal coal or bioethanol produced from cassava peels as a fuel. The cassava peels are sent to a reactor together with steam (T = 433 K and p = 1.5 Mpa) in order to break down the polysaccharides (carbohydrates) in the cassava peel biomass into monosaccharides so as to increase the hydrolysis performance obtained making use of the catalyzed steam explosion (CSE) method. The process involved lasts for 5 minutes, and then the pressure is lowered radically so as to produce an expansion of the lignocellulosic matrix and bring about in this way a separation of the individual fibers. Diluted sulfuric acid can be used here as a catalyst to reduce the xylose content by up to 90%, thus increasing the ethanol yield. A flash separator can be coupled to the system to remove by-products (such as Xylose). The next step is that of hydrolysis, in which the cellulose is broken down into glucose and reduced sugars by use of a simultaneous saccharification and fermentation (SSF) method. The mixture is sent then to two distillation columns coupled in series. In the first of these, CO₂ that is

left over can be released and an unreacted substrate such as unfermented sugar can be collected and be recirculated back to SSF. The second distillation column can be used then to increase the ethanol concentration from about 37 up to about 95% in wt. The ethanol that is produced can be used then for different purposes: as a carbon source for SRB, as a fuel for the boiler, or for commercialization purposes, for example. For the treatment of mine water, the bioethanol that is produced can be mixed with mine water that prior to this was inoculated with SRB in a mixing tank (Fig. 11). The mixtures can be sent to a bioreactor under anaerobic conditions to allow the reduction of sulfates to sulfides and the production of alkalinity to take place. Since such metals as calcium and magnesium do not form metal sulfides, the treated mine water should be sent, after passing through the clarifier, to an adsorption column for the removal of calcium and magnesium (Fig. 11).

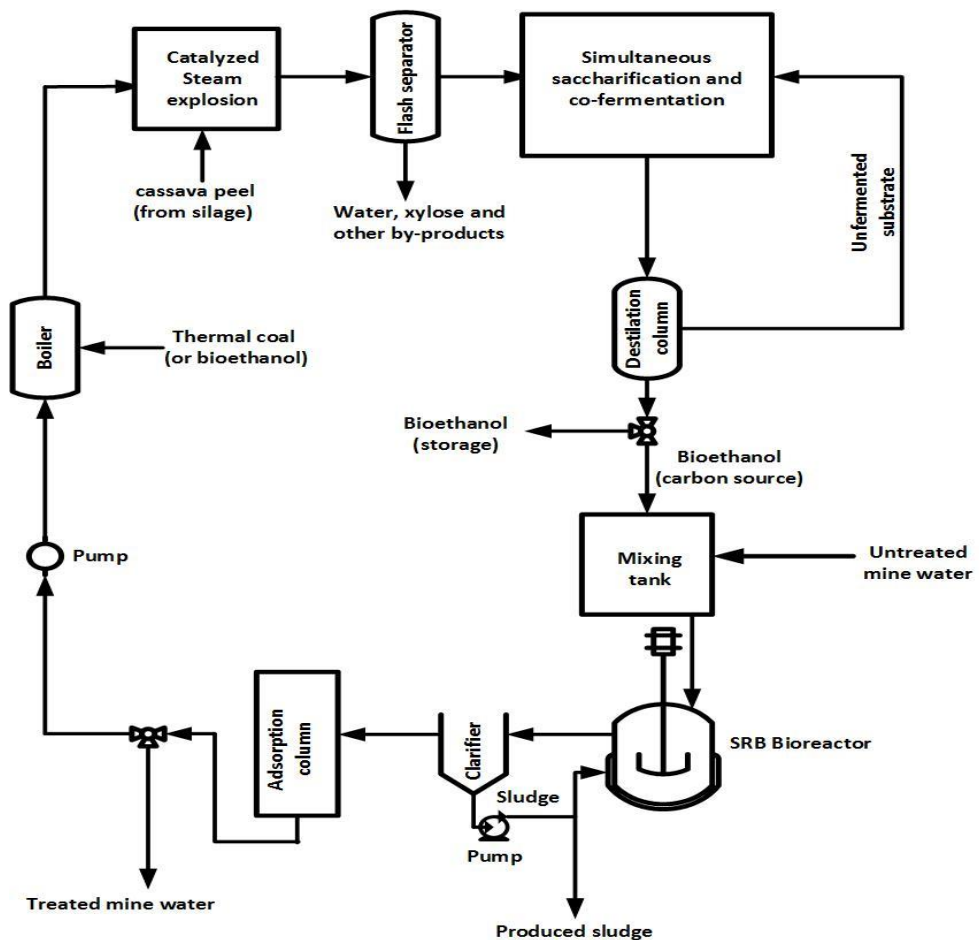

Figure 11. The proposal of a cost-effective mine water treatment unit for Moatize making use of SRB (Paper IV).

The use of agricultural waste to produce an adsorbent for the treatment of wastewater has been found to be both effective and efficient (Oyewo, et al., 2016). A study carried out by Oyewo et al (2016) showed that banana peels can be used to remove radioactive substances from real mine water. In the present study, cassava peels were used to treat coal mine water from Moatize by adsorption. To evaluate the performance of cassava peels during adsorption, experiments concerning the treatment of synthetic mine water were carried out on a lab scale. The results of the synthetic mine water that was produced are presented in Table 8. The concentrations of Ca and Mg are high and the concentrations of Hg, Mn and Co are low. The pH values are neutral.

Table 8. Concentrations in mg/L of synthetic mine water produced in the laboratory (Paper V).

Parameters	Ca	Co	Hg	Mg	Mn	pH
Maximum	151.00	0.041	0.064	67.50	2.50	8.0
Minimum	53.00	0.009	0.030	21.00	0.51	7.2
Mean	95.033	0.021	0.046	42.00	1.315	7.5
S.D.	38.140	0.001	0.013	15.04	0.694	0.339

The effectiveness of the cassava peels in adsorbing metal ions was determined by use of Eq. 12,

$$removal(\%) = \frac{C_o - C_e}{C_o} * 100\% \quad (12)$$

where C_o is the initial metal ion concentration and C_e is the equilibrium concentration of the metal ions expressed in mg/L . The removal efficiency is a function of pH values involved. Manipulation of the pH can lead to either improvement or worsening of the adsorption process. The removal efficiency, shown as a function of pH for Ca, Co, Hg, Mg and Mn, is presented in Fig. 12. For Ca, Mg and Hg, the removal efficiency increases with the pH values until alkaline conditions arise, this meaning that the adsorption of Ca, Mg and Hg have a high removal efficiency under alkaline conditions. In the case of Co, the maximum removal efficiency is attained at pH 4, after which it starts to decrease. For Mn the maximum removal efficiency is at pH 7.5 its starting to decrease after that. The reduction in removal efficiency for Co and Mn under alkaline conditions is probably due to certain complexes that are formed in the solution that precipitates, their reducing the availability of Co and Mn for adsorption.

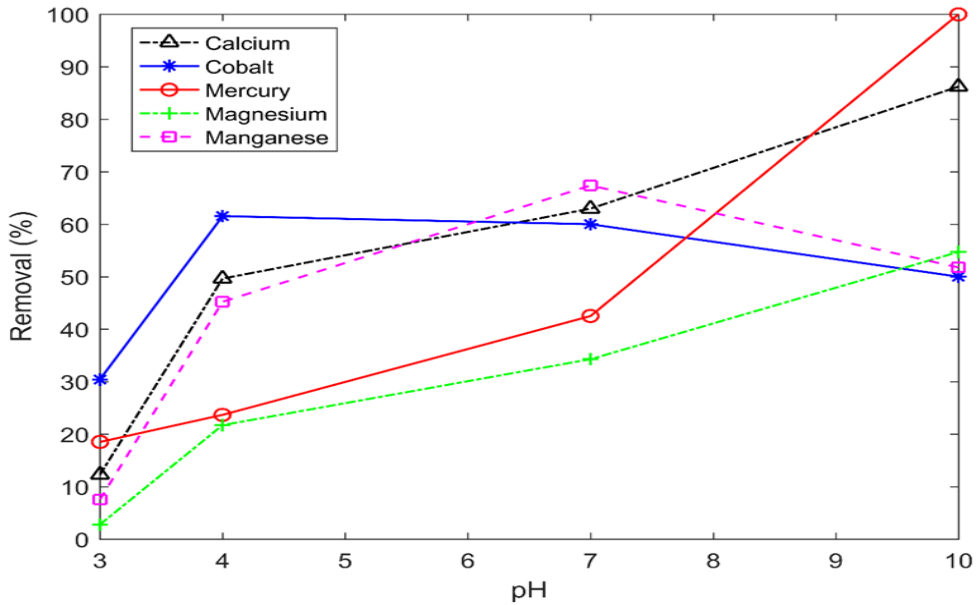

Figure 12. Effects of the pH values on the adsorption of metal ions when using cassava peels as an adsorbent (Paper V).

For determining the quantity of the metal ions adsorbed per unit time (q_t), use was made of Eq. 13,

$$q_t = \frac{(C_o - C_t) * V}{m} \quad (13)$$

where C_o and C_t are the concentration of the metal ions in the solution before and after sorption (in mg/L), respectively, m is the mass of the cassava peel material involved (in g), and V is the volume of the solution (in L). The effect of the contact time during the adsorption of Ca, Mg, Co, Hg and Mn into the cassava peels is presented in Fig. 13. A state of equilibrium for Ca was achieved after 50 minutes and for Mg after 20 minutes. The equilibrium was achieved for Co and Hg after 15 minutes and for Mn after 40 minutes.

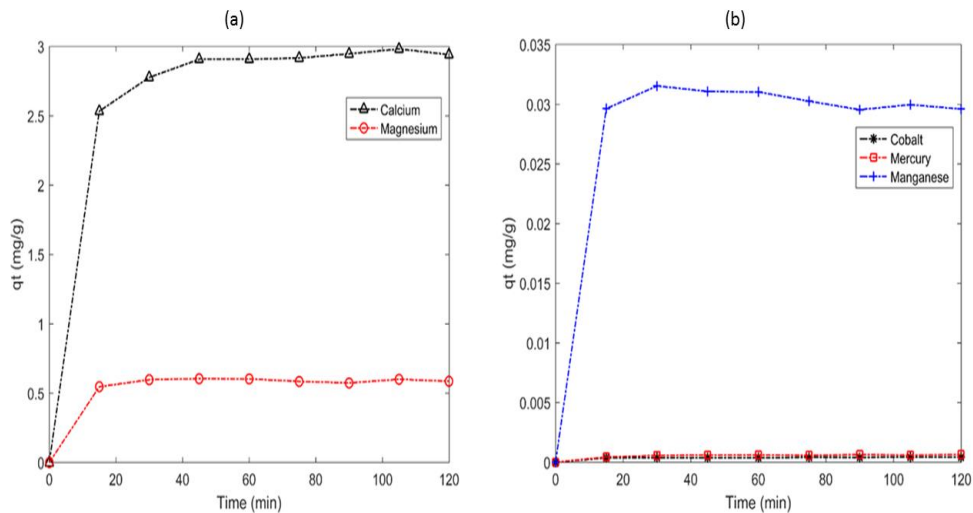

Figure 13. Effects of the contact time on the removal of Ca and Mg (a) and for Co, Hg and Mn (b) (Paper V).

For determining the adsorption isotherms, it was necessary to first determine the equilibrium concentrations of the various samples, these differing in their initial metal ion concentrations. The quantity of the metal ions adsorbed at equilibrium (q_e), expressed in mg/g , was determined using Eq.14,

$$q_e = \frac{(C_o - C_e) * V}{m} \quad (14)$$

where C_e is the equilibrium metal ion concentration in mg/L .

The results of the adsorption of *Ca*, *Mg*, *Co*, *Hg* and *Mn* for the Langmuir and the Freundlich isotherms, respectively, are presented in Table 9. The close fit of the experimental data to the Langmuir isotherms for Ca, Mg and Mn is confirmed by the high values of the respective correlation coefficients of 0.9885, 0.9987 and 0.9970. The separation factor R_L for *Ca*, *Mg*, *Co*, *Hg* and *Mn*, respectively, is in each case between 0 and 1, which means that the adsorption is favorable. The highest maximum adsorption capacity (q_{max}) was found for Ca ions, which had a value of 18.868 mg/g and for the Mg ions, which had a value of 2.597 mg/g . The other ions had very low values for q_{max} . The respective correlation coefficients in the Freundlich model for *Ca*, *Mg* and *Mn* are all very high, showing the model to have fitted very well. In contrast, for *Hg* and *Co* the model is poorly fitted to the experimental data. The values of n (empirical constant) are in the interval $1 < n < 10$ for *Ca*, *Mg*, *Co* and *Hg*, indicating that for these the adsorption is favorable. The

value of n for Mn is 0.78, i.e less than 1.0 ($n < 1$), which means that there the adsorption is unfavorable.

Table 9. Langmuir and Freundlich isotherm constants for Ca, Mg, Co, Hg and Mn ions adsorbed into cassava.

Metal ions	Langmuir isotherms				Freundlich isotherms		
	$q_{max}(mg/g)$	$b(L/mg)$	R^2	R_L	n	$K_F (mg/g)$	R^2
Ca	19.0	0.006	0.99	0.59	1.0	0.12	0.98
Mg	2.6	0.018	0.99	0.58	1.3	0.07	0.99
Co	0.0083	8.2	0.82	0.82	1.3	0.02	0.75
Hg	5×10^{-4}	226	0.22	0.09	3.0	0.0002	0.24
Mn	0.08	0.99	0.99	0.49	0.8	0.16	0.99

Climate change leads to a rise in temperature, the frequency and the magnitude of extreme weather events changing, the precipitation levels and the seasonal patterns changing worldwide (Pearce, et al., 2011). Such changes have a strong impact on the mining industry. The changes and variability in climate that results can exacerbate the adverse impact of surface mining in Moatize. In Canada, climate change has been perceived as having a negative impact upon mining activities (Ford, et al., 2010). Both the precipitation and the temperature in Moatize, play an important role in the quality and quantity of the mine water there stemming from the coal mines. Fig. 14 shows the temperature and the precipitation in Moatize during the period of 1953 and 2015. There is a positive trend for the temperature, indicating clearly the temperature to be increasing. The variability of the precipitation during these years as a whole is high, although especially after the 1980s.

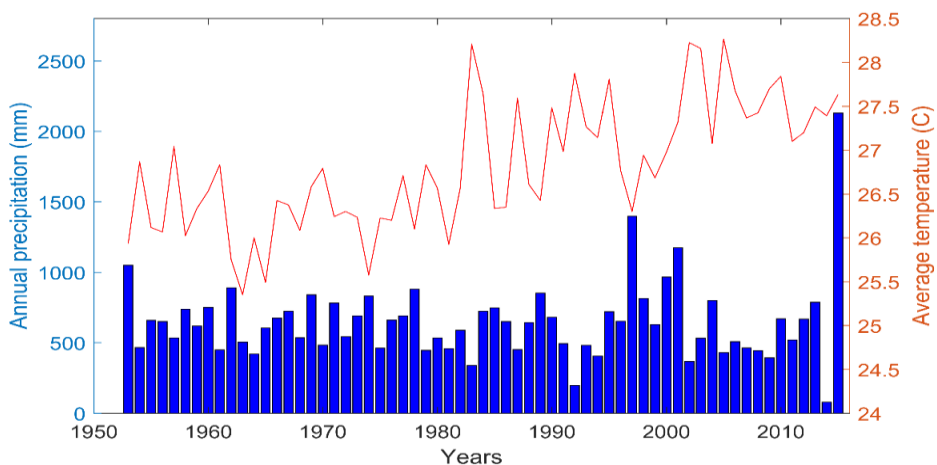

Figure 14. Temperature and precipitation in Moatize during the period of 1953 to 2015 (Paper VI).

According to Nordstrom (2007), precipitation events in the western parts of the United States have led both to increases and to decreases in pH, and in the concentration of metals and in the load stemming from mine wastes in the rivers there. He noted there being variations in the concentration and load of mine water caused by seasonal variations in climate. He suggested that the capacity of mine water treatment facilities there should be increased in order to deal more adequately with extreme events caused by climate change, rather than expecting the average conditions from previous years to simply continue (Nordstrom, 2007). The level of concern worldwide regarding pollution caused by tailing dam seepage, dam wall failure and the direct discharge of tailings into the water resources has clearly increased. In addition, the extreme weather events that are related to climate change can be expected to increase the risk of pollution in tailing management (Edraki, et al., 2014). In Vietnam, where tropical rains prevail, the amount of coal mine drainage from open pit mines is 2 to 3 times higher in the rainy season than to the dry season. The coal mines in Vietnam are faced with two main difficulties in the rainy season that are due to climate change: its being difficult to stabilize the quality of the mine water that goes to the treatment plant, thus making it difficult to define the treatment capacity of the plant; and there being large seasonal variations in the quality of the mine water (Mien, 2012).

The experience that other countries have had concerning pollution stemming from mining operations and exacerbated by climate events can be used to help Moatize prevent such pollution from occurring.

In order to obtain a clear picture of the variability in the precipitation that occurs in Moatize during the rainy season, a boxplot of this was used for the period of 1953 to 2015 (Fig.15). The monthly precipitation in Moatize varies between values of less than 100 mm to values above 500 mm. The wettest month on the average in terms of precipitation is January. February was found to be more susceptible to the occurrence of floods.

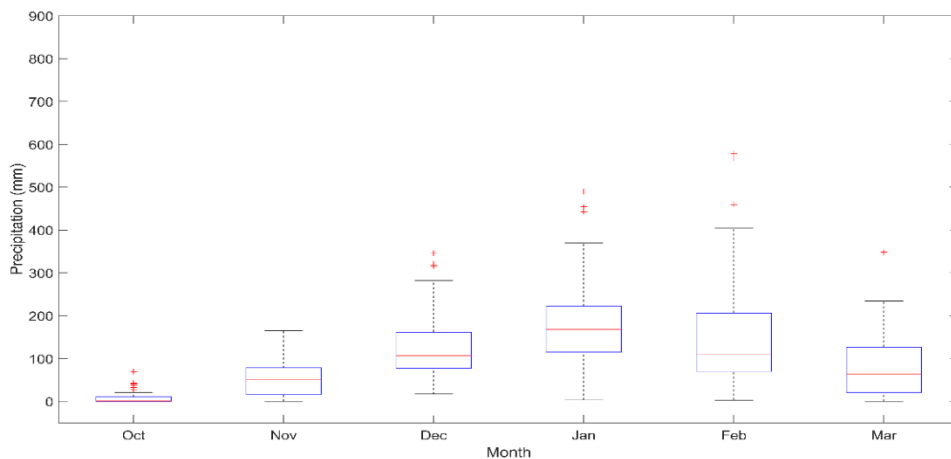

Figure 15. A boxplot of the monthly precipitation during each month of the rainy season in Moatize during the period of 1953 to 2015(Paper VI).

The monthly mean temperatures in Moatize for the period of 1953 to 2015 are presented in Fig. 16. Looking at the rainy season (October to March), one can note that the mean temperature then is high. This is good for the development of acidithiobacillus ferrooxidans bacteria, which enhance the oxidation of Fe^{2+} to Fe^{3+} (SME, 2008). The optimum growth temperature for these bacteria is between 25 to 35°C, which is the case during the rainy season (Ahonen & Tuovinen, 1989). The presence of these bacteria can lead to the oxidation rates of sulfide being up to eight times as high as they would otherwise be, thus accelerating the production of AMD.

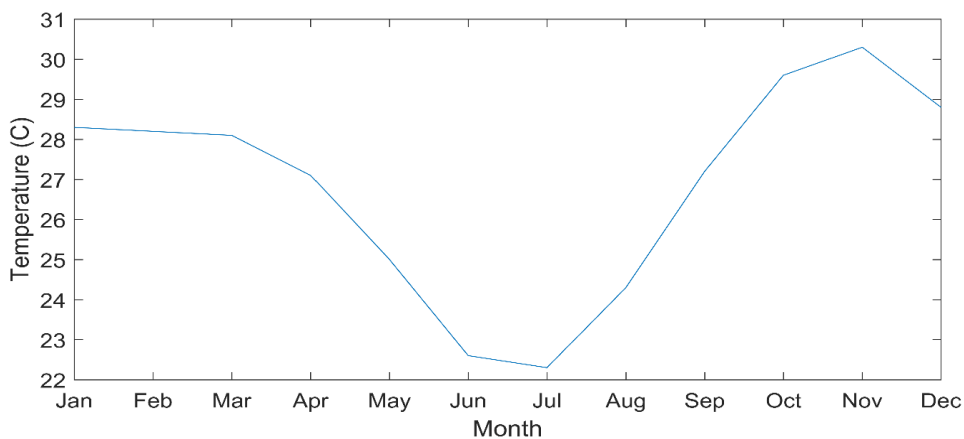

Figure 16. Average monthly temperatures during the period of 1953 to 2015 in Moatize(Paper VI).

Based on both Figs. 15 and 16, one can see that it is to be expected that the period of high pollution load stemming from the tailings, pits and waste piles that are present in the Moatize is between about November and February.

To moderate the risks associated with the impact of climate changes on the mining sector in Moatize, it is necessary to identify and to anticipate the vulnerabilities that exist. To achieve such a goal, the mining industries, the government and the stakeholders involved need to be pro-active in the perspective regarding this that they take.

Achieving satisfactory water management in the lower Zambezi River basin should be given high priority by the government, the mining industries and other stakeholders that benefit from what takes place in the basin. The Zambezi River basin accounts for about 50% of the total surface water resources of Mozambique, as well as 80% of hydropower potential, making it the most important river basin in the country (FAO, 2015). According to FAO (2015), the total amount of water that was withdrawn in the country during 2015 was 1473 million m³/year, 73% (1075 million m³/year) of which is accounted for by agriculture, 25% (368 million m³/year) by the municipalities and 2% (30 million m³/year) by industrial sector. For the industrial sector, the amount of water used increased from 15 million m³ in the year 2000 to 30 million m³ in 2015. The amount of water used in the industrial sector doubled, due mostly to the coal mining industries located within the country. There is a need to start using water in a sustainable way. Sustainable mining can be achieved by involving all of the stakeholders that deal with water in the Zambezi river basin in the task of working for this. MOPHRH (the Ministry of Public Work, Habitation and Water Resources), MITADER (the Ministry of the Environment), ARA Zambezi, MISAU (the Ministry of Health), MINAG (the Ministry of Agriculture), the local communities that are involved, CRA (the Water Supply Regulation Council), farmers and fishermen, mining industries, FIPAG (the Water Supply Investment and Assets Fund), and various academic institutions (Fig.17) should direct their united efforts at the goal of integrating and coordinating the different activities carried out by each of the them for protection of the Zambezi River basin. MITADER is responsible for environmental protection of it. ARA Zambezi is responsible for water administration in the Zambezi River basin. MISAU is responsible for promoting hygienic policies there. MINAG is responsible for water used for irrigation. FIPAG is responsible for the water supply and the sanitation infrastructures in the main cities of Mozambique. CRA has the function of being the water sector regulator. A framework and a group of persons associated with it composed of all of the stakeholders connected with the water sector in Moatize is proposed here (see Fig. 17). It can be argued that group composed of members of each organization referred to here as “the proposed group” should be created and be coordinated by MITADER. The coal mining companies in Moatize

should then inform the group of how much water they withdraw from the local aquifers or from the rivers, what amount of mine water they recycle and how much of mine water is discharged into the local environment. MITADER should be informed regularly about the quality of the mine water produced there, and MITADER and ARA-Zambezi should be able to do the monitoring of the water quality in Moatize. The other stakeholders should be informed and should also contribute to achieving better water management in the lower Zambezi River basin. The group should also discuss the legacy of coal mines in Moatize after mining closes down. From the experience of other countries, one can note that closed mines are often abandoned, posing a risk for the health of local communities that may shift to having to drink polluted water. The government, represented by MITADER, should promote discussion of who should be responsible for the coal mines after their being closed down. How will the mine water from the pits in the area be treated? According to Kruse & Younger (2009), even after the closing of a mine, new pollutants may still be discharged. The possibility of using a passive treatment system in the future for treating mine water and the question who should pay for it, since the government does not have sufficient resources for that should be analyzed. How can the present coal mining companies contribute to the future of the water management in Moatize, even if they are not there anymore? MITADER, various academic institutions and the mining companies should develop an action plan, based on such matters as an assessment of the tailing dam break in Moatize aimed to identifying the consequences of failure of the dam. Such an assessment should include estimates of the breach parameters, flowrate going out, and an inundation map of the area to show the potential extent of the flow and the impacts that it can have downstream (Rourke & Luppnow, 2015). Since all of the coal mines in Moatize have tailing dams, such a study should be concerned with all of them. Climate change should be taken account of in the treatment of mine water and in the management of the tailings. Due to the variability of the climate in Moatize, the quantity and the quality of the mine water also vary making treatment of the mine water there difficult. Various academic institutions can help the mining companies perform such studies, but it is essential for this purpose that the mining companies allow members of the proposed group referred to above to visit their companies for carrying out such investigation.

Cassava peels are readily available in the country and are usually simply discarded. Bioethanol can be produced from them, however, thus creating a market for them and also creating an opportunity for local farmers to gain various benefits from them. The bioethanol could be used in the treatment of mine water containing considerable amounts of metals, metalloids and sulfate. MINAG, which is the ministry of agriculture, together with different academic institutions should take the responsibility for promoting this idea among the mining companies involved. Mine

water treated by use of SRB and of adsorption could be used for the irrigation of native plants so as to produce steam for ethanol production.

The proposed group should have the training needed to understand the basic processes behind the mining activities in question and to enable them to also contribute with ideas that can be of use. The academic institutions involved should prepare short courses at least in their endeavors by the mining companies as well, to train the members of the proposed group to adequately understand the mining and environment interaction involved. There is a strong need of providing independent and impartial scientific assessment of projects carried out by mining companies prior to their approval (Curell, et al., 2017). A role of this sort could be taken on by appropriate academic institutions from Mozambique. MISAU should inform the local communities involved regarding the risks associated with mining pollution in order to help avoid public health problems in the future.

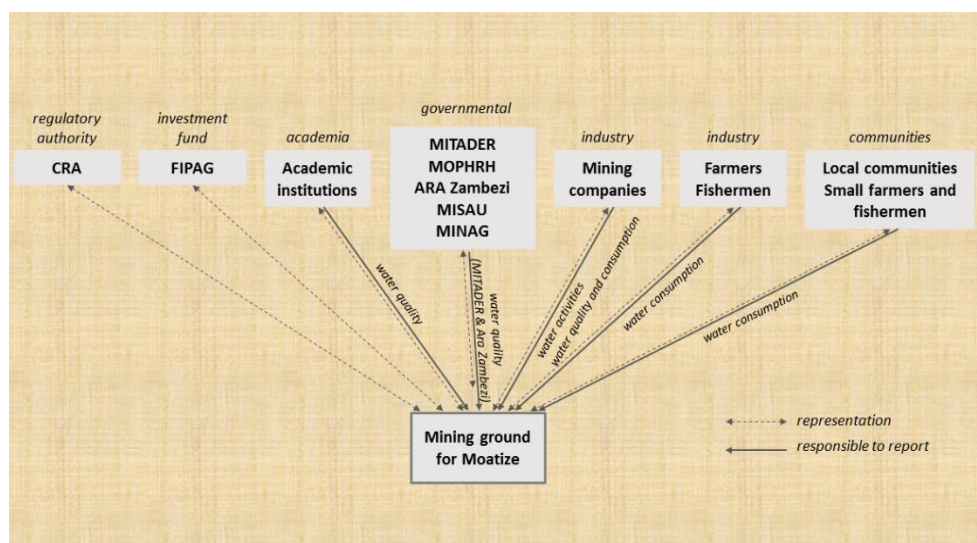

Figure 17. A proposed framework for achieving sustainable mining in Moatize (Paper VI).

FIPAG, as responsible for water supply, should participate actively in the proposed group since the costs of drinking water treatment are directly related to the pollution that the mining companies in the area give rise to. Since the quality of the drinking water needs to be high, the costs are also high. CRA in serving as a regulator, should also take part in the activity of the proposed group concerned with protecting the interests of drinking water consumers.

5. Limitation of the study

There were many limitations that were placed on what could be accomplished in the present study better:

Most of the mining companies did not allow us to perform research on their properties, which means that a clearer picture of what is happening in Moatize than that which was obtained here is needed.

The mine waste and mine water samples that were collected in Moatize were not sufficient to describe all that was going on in the coal mining area. There is a need to perform a field study to collect samples from each of the in Moatize to investigate in greater detail what happened during the different seasons.

Another problem in the present study was a lack of certain data that would have been very useful to have from governmental institutions and coal mining institutions.

The study area of central interest is located in the center of Mozambique, whereas the present study was carried out in Lund, Sweden.

The static and leaching tests were carried out in a laboratory, which means that account was not taken of the climatic conditions in the study area of interest.

Most of the technical personnel that was consulted in the coal mines was not as well qualified as would have been desirable, the information provided by them thus not being as useful as it might otherwise have been.

6. Conclusions and future outlook

In the present study, both active and passive treatment of mine water were discussed, advantages and disadvantages of methods of each of these two types being presented. Static and leaching tests were carried out to investigate the possibility of mine waste in Moatize generating AMD. Assessments using multivariate statistics analysis were carried out to assess the geochemical processes that can impact upon the mine water leaching from waste rock pile. The possibility of using local resources such as cassava peels to treat polluted mine water in Moatize was investigated. Cassava peels were used to treat the mine water through adsorption on a lab-scale making use of synthetic mine water. Since climate change is a cross-sectional matter, the impact of surface mining in Moatize exacerbated by climate change was investigated. The main conclusions that can be drawn from results of the present study are as follow:

- Active treatment generally remove pollutants from mine water quite effectively, yet the operating costs, maintenance costs and investment costs tend to be high. Active treatment is suitable for mines that are still in operation. Obvious disadvantages of these methods, however, are the addition of chemicals and the generation of toxic sludge. Passive treatments are suitable for closed mines, since such they require less maintenance, have lower operating costs and they are not in need of electrical power. Obvious disadvantages of passive treatment are that larges areas and longer retention times are needed in order to operate effectively (Paper I);
- Based on static and kinetic tests that were conducted, it can be concluded that for coal mine M the possibility of AMD generation is unlikely, but that for coal mine R there is a risk of AMD generation occurring when the neutralizing material is used up. The mine water in Moatize has a high content of sulfate, calcium, magnesium and manganese and is close to being neutral in pH (Paper II);
- On the basis of the multivariate statistical analysis that was carried out (Paper III), it was found that the geochemical processes that impact upon the mine water in Moatize are those of the oxidation of sulfide minerals, and neutralization of the acidic water by silicates and carbonates. The high content of sulfate in the mine water is due to sulfide oxidation, the high

content of calcium, magnesium and manganese being due to weathering of the carbonates and silicates (Paper III);

- The treatment of mine water by use of SRB coupled with adsorption appears to be a feasible and cost-effective method for the treatment of mine water in Moatize. Ethanol obtained from cassava peels can be used as a carbon source for SRB, as fuel in the boiler to produce steam and for commercialization. Mine water that have been treated can be used for irrigation in the lower Zambezi river basin (Paper IV);
- The use of cassava peels as an adsorbent in the treatment of mine water was found to be successful for Ca, Mg and Hg under alkaline conditions, for Mn under neutral conditions and for Co under acidic condition. It can be concluded that cassava peels can be used as an adsorbent to remove Ca and Mg that are unable to form a metal sulfide during treatment with SRB (Paper V);
- The temperature trend in Moatize is increasing, meaning that the oxidation rates of the sulfide minerals available in mine wastes will also increase, leading to an increase in the pollution load. The period from November to the end of February appears to have the greatest pollution load. The flow in the Revúbué River is directly dependent upon the precipitation that occurs during the rainy season and polluted mine water discharge should be avoided. The government, the mining industry and other stakeholders should work together so as to achieve sustainable mining operations (Paper VI).

There are many things that still need to be done in Moatize in order to achieve a better understanding of what is happening there regarding mine water and mine wastes. Various future activities that are in need of being carried out in Moatize are the following:

- Discussing the proposed guidelines with the government, the mining industries involved and other stakeholders. Academic institutions together with MITADER should best be in charge of this task;
- Creating the proposed group for achieving better water management in lower Zambezi. MITADER and the mining companies are the institutions that should best be involved in the creation of the proposed group;
- Assessing the possibilities of using mine water for different purposes in the case of water shortage. This task could be carried out by the mining companies, by MINAG and by academic institutions;

- Promoting the principle ‘the polluter pays’ for mines that fail to follow the guidelines. MITADER and ARA-Zambezi should best be responsible for this task;
- Providing short courses for stakeholders concerning mine water and mine wastes. This task should be carried out by different academic institutions within the country;
- Conducting static and kinetic tests in the field. Both academic institutions and mining companies should be involved in this task;
- Collecting mine water from all the coal mines and analyzing it carefully, a task that can be carried out by MITADER, ARA-Zambezi and academic institutions;
- Treatment being carried out on a lab-scale by mining companies and academic institutions in which use is made of sulfate reducing bacteria;
- Having the prevention methods used in Moatize evaluated by academic institutions and by MITADER;
- Taking climate change into account so as to avoid failures of tailing dams, and the overflow of tailing dams and of pits during extreme events (such as floods). MITADER, ARA-Zambezi and academic institutions should be in charge of this task;
- Assessing the ground water contamination to determine how polluted it is, a task that can be carried out by MITADER, MISAU, ARA-Zambezi and by various academic institutions;
- Discussing the legacy of coal mines after mining operations have been terminated, a matter that can be promoted by MITADER with support of various academic institutions.

References

- Adekunle, A., Orsat, V. & Raghavan, V., 2016. Lignocellulosic Bioethanol: A review and Design Conceptualization Study of production from Cassava Peels. *Renewable and Sustainable Energy Reviews*, Volume 64, pp. 518 - 530.
- Adibee, N., Osanloo, M. & Rahmanpour, M., 2013. Adverse effects of coal mine waste dumps on the environment and their management. *Environmental Earth Science*, Volume 70, pp. 1581 - 1592.
- Ahonen, L. & Tuovinen, O., 1989. Microbial oxidation of ferrous iron at low temperature. *Applied and Environmental Microbiology*, 55(2), pp. 312 - 316.
- Assembleia da República, 2004. *Decreto 18/2004 de 2 de Junho*, Maputo: Imprensa Nacional.
- Bank, W., 2005. *The Role of Water in the Mozambican Economy-Identifying Vulnerability and Constrains to Growth*, s.l.: World Bank.
- Chowdhury, A., Sarkar, D. & Datta, R., 2015. Remediation of acid mine drainage-impacted water. *Current Pollution Reports*, Volume 1, pp. 131 - 141.
- Curell, M. et al., 2017. Problems with the application of the hydrogeological science to regulation of Australian mining projects: Carmichael mine and Doongmabulla springs. *Journal of Hydrology*, Volume 548, pp. 674 - 682.
- Daniels, W., Zipper, C. & Orndorff, Z., 2014. Predicting release and aquatic effects of total dissolved solids from Appalachian USA coal mines. *International Journal of Coal Science & Technology*, 2(1), pp. 152 - 162.
- Dharmappa, H., Sivakumar, M. & Singh, R., 1995. *Wastewater minimization and reuse in mining industry in Illawara region*. Wollongong, International Mine Water Association.
- DNA, 1999. *Water Resources of Mozambique*, Cooperation Portugal - Mozambique: Ministry of Public Works and Housing.
- Edraki, M. et al., 2014. Designing mine tailings for better environmental, social and economic outcomes: a review of alternative approaches. *Journal of Cleaner Production*, Volume 84, pp. 411 - 420.
- EPA, 2006. *Management and treatment of water from hard rock mine..* Washington,DC: United States Environmental Protection Agency.
- FAO, 2015. *Mozambique-AQUASTAT*, s.l.: FAO.
- Farajzadeh, M. & Monji, A., 2004. Adsorption characteristics of wheat bran towards heavy metal cations. *Sep Purif Technol*, 38(3), pp. 197 - 207.

- Fernandes, P. et al., 2015. The thermal history of the karoo Moatize-Minjova basin, Tete province, Mozambique: An integrated vitrinity reflectance and apatite fission track thermochronology study.. *Journal of African Earth Sciences*, Volume 112, pp. 55-72.
- Ford, J. D. et al., 2010. Perceptions of climate change risks in primary resource use industry: a survey of the Canadian mining sector. *Reg Environ Change*, Volume 10, pp. 65 - 81.
- Fox, A. P., Lottermoser & G., B., 2015. A critical review of acid rock drainage prediction methods and practices. *Minerals Engineering*, Volume 82, pp. 107 - 124.
- Geldenhuis, A., Maree, J., Beer, M. & Hlabela, P., 2003. An integrated limestone/lime process for partial sulphate removal. *The journal of the South African Institute of Mining and Metallurgy*, pp. 345 - 354.
- Hartman, H., 1987. *Introductory Mining Engineering*. 633 pp ed. New York: Wiley.
- Hedin, R., Narin, R. & Kleinmann, R., 1994. *Passive treatment of coal mine drainage*, s.l.: Bureau of Mines.
- Hussain, A., Hasan, A., Javid, A. & Qazi, J. I., 2016. Exploited application of sulfate-reducing bacteria for concomitant treatment of metallic and non-metallic wastes: a mine review. *Biotechnology*, Volume 6, p. 119.
- INE, 2015. *Anuário Estatístico*, Maputo: Instituto Nacional de Estatística.
- IPCC, 2001. *Climate Change 2001: Impacts, Adaptation, and Vulnerability*. First Edition ed. New York: Cambridge.
- Jain, M. K. & Das, A., 2017. Impact of mine waste leachates on aquatic environment: a review. *Current Pollution Reports*, 3(Springer), pp. 31 - 37.
- José, D. & Sampaio, C., 2011. *Estado da arte da mineiracao em Mocambique: Caso de carvão de Moatize.*, Tete: Universidade Federal do Rio Grande do Sul.
- Kirby, C., Dennis, A. & Kahler, A., 2009. Aeration to degas CO₂, Increase pH and increase iron oxidation rates for efficient treatment of alkaline mine drainage. *Applied Geochemistry*, Volume 24, pp. 1175 - 1184.
- Kruse, N. A. & Younger, P. L., 2009. Sinks of iron and manganese in underground coal mine workings. *Environmental Geology*, Volume 57, pp. 1893 - 1899.
- Kuyucak, N., 2006. *Selecting suitable methods for treating mining effluent*, s.l.: Golder Association.
- Laszlo, J. & Dintzis, F., 1994. Crop residue as ion-exchange materials-treatment of soybean hull and sugar-beet fiber(pulp) with epichlorohydrin to improve cation-exchange capacity and physical stability. *Journal of Applied Polymer Science*, 52(4), pp. 531 - 538.
- Liamlean, W. & Annachatre, A., 2007. Electron donors for biological sulfate reduction. *Biotechnology Advances*, Volume 25, pp. 452 - 463.
- Lottermoser, B. G., 2010. *Mine Wastes: characterization, treatment and environmental impacts*. Third edition ed. London: Springer.
- Lottermoser, B. G., 2010. *Mine Wastes: Characterization, Treatment and Environmental Impacts*. Third Edition ed. Townsville Queensland: Springer.

- Magdziorz, A. & Sewerynski, J., 2000. *The Use of Membrane Technique in mineralize Water Treatment For Drinking and Domestic porposes at Pakoj Coal Mine District Under Liquidation*, s.l.: Central Mining Institute, Department of Water Protection.
- Matsinhe, N. P., 2008. *Challenges and Opportunities for Safe Water Supply in Mozambique*, Lund-Sweden: Lund University.
- Mhlongo, S. E. & Amponsah-Dacosta, F., 2015. A Review of Problems and Solution of Abandoned Mines in South Africa. *International Journal of Mining, Reclamation and Environment-Taylor & Francis*, 30(4), pp. 279-298.
- Mien, T., 2012. Mine wste water management and treatment in coal mines in Vietnam. *Geosystem Engineering*, 15(1), pp. 66 - 70.
- Nadagouda, M. et al., 2011. Novel thermal stable poly(vinyl chloride) composites for sulfate removal. *Journal of Hazard Material*, 188(1-3), pp. 19 - 25.
- Naidoo, S., 2017. *Acid Mine Drainage in South Africa: Development Actors, Policy Impacts and Broader implication*. First Edition ed. Pretoria: Springer.
- Nariyan, E., Sillanpää, M. & Wolkersdorfer, C., 2017. Electrocoagulation treatment of mine water from the deepest working European metal mine - performance, isotherm and kinetic studies.. *Separation and Purification Technology*, Volume 177, pp. 363 - 373.
- NEPAD, 2013. *Mozambique Country Water Resource Profile*, s.l.: NEPAD.
- Nordstrom, D. K., 2007. *Effects of seasonal and climate change on water quality from acid rock drainage in the Wstern United States*. Cagliari, Italy, Internatinal Mine Water Association.
- Northey, S. et al., 2016. Water footprinting and mining: where are the limitations and opportunities?. *Journal of Cleaner Production*, Volume 135, pp. 1098 - 1116.
- Oyewo, O. A., Onyango, M. S. & Wolkersdorfer, C., 2016. Application of banana peels nanosorbent for the removal of radioactive minerals from real mine water. *Journal of Environmental Radioactivity*, Volume 164, pp. 369 - 376.
- Pearce, T. et al., 2011. Climate change and mining in Canada. *Mitig Adapt Strat Glob Change*, Volume 16, pp. 347 - 368.
- Pinto, P., Al-Abed, S., Balz, D. & Butler, B., 2016. Bench scale and pilot scale treatment technologies for the removal of total dissolved solids from coal mine water: a review. *Mine Water and Environment*, Volume 35, pp. 94 - 112.
- Pondja, E., Persson, K. & Matsinhe, N., 2015. *Proposal of standard guideline for effluent water in coal mine in Mozambique*. Bangkok, International Journal of Management and Applied Science.
- Rico, M. et al., 2008. Reported tailing dam failures. A Review of the European incident in the worldwide context. *Journal of Hazard Material*, Volume 152, pp. 846 - 852.
- Rourke, H. & Luppnow, D., 2015. *The risks of excess water on tailing facilities and its application to dam-break studies*. Sydney, SRK consulting.
- Sarver, E. & Cox, A., 2013. Salt: an emerging water concern for the global mining and minerals industries. *Mining Technology*, 122(3), pp. 145 - 152.
- Schoenberger, E., 2016. Environmentally sustainable mining: The case of tailing storage facilities. *Resources Policy*, Volume 49, pp. 119 - 128.

- Simate, G. S. & Ndlovu, S., 2014. Acid mine drainage: Challenges and opportunities. *Journal of Environmental Chemical Engineering*, Volume 2, pp. 1785 - 1803.
- SME, 2008. *Basics of Metal Mining Influenced Water*. Volume 1 ed. Colorado: Society for Mining, Metallurgy, and Exploration, Inc. (SME).
- Soni, A. K. & Wolkersdorfer, C., 2015. Mine Water: Policy perspective for Improving Water Management in the Mining Environment with Respect to Developing Countries. *International Journal of Mining, Reclamation and Environment*, 30(2), pp. 115 - 127.
- Steed, V. et al., 2000. Development of a sulfate reducing biological process to remove heavy metals from acid mine drainage. *Water Environ Res*, 72(5), pp. 530 - 535.
- Trumm, D., 2010. Selection of active and passive treatment system for AMD - Flow chart for New Zealand conditions.. *Geology and Geophysics*, Volume 53, pp. 195 - 210.
- Tsukamoto, T. & Miller, G., 1999. Metanol as a carbon source for microbiological treatment of acid mine drainage. *Water Resources*, 33(6), pp. 1365 - 1370.
- VALE, 2015. *Sustentabilidade Mocambique*, Maputo: VALE.
- Wang, X., Li, Z.Z & Sun, C., 2009. A comparative study of removal of Cu(II) from aqueous solutions by locally low cost materials: marine macroalgae and agricultural by-products. *Desalination*, 235(1-3), pp. 146 - 159.
- Webb, J., McGinness, S. & Lappin-Scott, H., 1998. Metal removing by sulfate reducing bacteria from natural and constructed wetlands. *Journal of Applied Microbiology*, 84(2), pp. 240 - 248.
- Wolkersdorfer, C., 2008. *Water management at abandoned flooded underground mines*. First edition ed. Berlin: Springer.
- Wolkersdorfer, C. & Kleinmann, R., 2011. *Best practice of mine water management and treatment - an international review*. s.l., s.n.
- Zipper, C., Skousen, J. & Jage, C., 2011. *Passive treatment of acid mine drainage*, Blacksburg: Virginia Tech.

