



LUND UNIVERSITY

Long-path monitoring of NO₂ with a 635 nm diode laser using frequency-modulation spectroscopy

Somesfalean, Gabriel; Alnis, J; Gustafsson, U; Edner, Hans; Svanberg, Sune

Published in:
Applied Optics

2005

[Link to publication](#)

Citation for published version (APA):

Somesfalean, G., Alnis, J., Gustafsson, U., Edner, H., & Svanberg, S. (2005). Long-path monitoring of NO₂ with a 635 nm diode laser using frequency-modulation spectroscopy. *Applied Optics*, 44(24), 5148-5151.
http://www.opticsinfobase.org/ludwig.lub.lu.se/DirectPDFAccess/DC4AEE3E-BDB9-137E-C018946E6F05B086_84890.pdf?da=1&id=84890&seq=0&CFID=4168538&CFTOKEN=87074219

Total number of authors:
5

General rights

Unless other specific re-use rights are stated the following general rights apply:
Copyright and moral rights for the publications made accessible in the public portal are retained by the authors and/or other copyright owners and it is a condition of accessing publications that users recognise and abide by the legal requirements associated with these rights.

- Users may download and print one copy of any publication from the public portal for the purpose of private study or research.
- You may not further distribute the material or use it for any profit-making activity or commercial gain
- You may freely distribute the URL identifying the publication in the public portal

Read more about Creative commons licenses: <https://creativecommons.org/licenses/>

Take down policy

If you believe that this document breaches copyright please contact us providing details, and we will remove access to the work immediately and investigate your claim.

LUND UNIVERSITY

PO Box 117
221 00 Lund
+46 46-222 00 00

Long-path monitoring of NO₂ with a 635 nm diode laser using frequency-modulation spectroscopy

Gabriel Somesfalean, Janis Alnis, Ulf Gustafsson, Hans Edner, and Sune Svanberg

In situ monitoring of traffic-generated nitrogen dioxide (NO₂) emissions using long-path absorption spectroscopy is reported. High-sensitivity detection of NO₂ is achieved by employing two-tone frequency-modulation spectroscopy at a visible absorption band using a tunable high-power diode laser operated around 635 nm. A real-time absorption spectrometer is accomplished by repetitively applying a rectangular current pulse to the diode-laser operating current, allowing detection of isolated NO₂ absorption lines. A detection limit of 10 µg/m³ for NO₂ at atmospheric pressure using a 160 m absorption path is demonstrated. Continuous monitoring of NO₂ over a road intersection at peak traffic is performed. © 2005 Optical Society of America

1. Introduction

There is a large interest in detection and precise measurement of nitrogen dioxide (NO₂), which is a combustion-generated atmospheric trace gas acting as an important agent in several chemical cycles in the atmosphere. Optical monitoring applications in the field of air-quality control and traffic-emission monitoring are employing, e.g., differential optical absorption spectroscopy^{1,2} (DOAS) and light detection and ranging^{3,4} (LIDAR) techniques, both methods being suitable to use in conjunction with long absorption path lengths. Very few remote-sensing line-of-sight measurements have been performed employing tunable diode-laser spectrometers for atmospheric NO₂ monitoring.⁵ The majority of diode-laser-based applications for NO₂ detection utilize multiple-pass absorption cells, mostly at reduced pressures in order to minimize line broadening.^{6–11} Such an arrangement has the disadvantage of introducing unwanted optical fringes due to etalon effects,⁶ and of depending on a gas-extraction procedure, which is prone to introduce measurement

errors. In the present work, long-path absorption in combination with a retroreflector is used instead, making remote sensing over several hundred meters possible, to be compared with the point-monitoring mode obtained in a multiple-pass absorption cell configuration. Thereby it is possible to obtain the pollutant concentrations in a large volume with less sensitivity to local fluctuations.

Field instruments for air pollution monitoring are preferably operated at ambient pressure, with the disadvantage of increased line broadening and reduced peak absorption, which leads to lower detection sensitivity. The NO₂ spectrum is comparatively dense (~10 lines/cm⁻¹), and lines are partially overlapping at ambient atmospheric pressure due to collisional broadening. Another problem that has to be considered is interference from other molecular species, such as oxygen and water lines. The probing wavelength is therefore carefully selected to overlap a strong isolated absorption line of the gas, which has sufficiently well-resolved features and does not interfere with other species. At wavelengths longer than 350 nm, the absorption spectrum of NO₂ exhibits sharp spectral features,¹⁰ that extend over the blue region into the visible wavelength region. We use a diode laser emitting at a wavelength around 635 nm in order to probe the red wing of the X²A₁ → A²B₂ visible absorption band of NO₂.

Previously a sensitivity of 0.2 µg/m³ has been demonstrated using a gas cell at low pressure and monitoring with a cryogenically cooled diode laser operating around 6.2 µm.⁶ Measurements using near-infrared⁷ or red diode lasers^{9,10} have been performed achieving sensitivities of a few µg/m³. The

The authors were with the Department of Physics, Lund Institute of Technology, P.O. Box 118, S-22100 Lund, Sweden, when this research was performed. The permanent address for J. Alnis is Institute of Atomic Physics and Spectroscopy, University of Latvia, Rainis Boulevard 19, LV-1586 Riga, Latvia. The present address for U. Gustafsson is Science and Technology International, 733 Bishop Street, Suite 3100, Honolulu, Hawaii 96813.

Received 2 November 2004; revised manuscript received 18 March 2005; accepted 8 April 2005.

0003-6935/05/245148-04\$15.00/0

© 2005 Optical Society of America

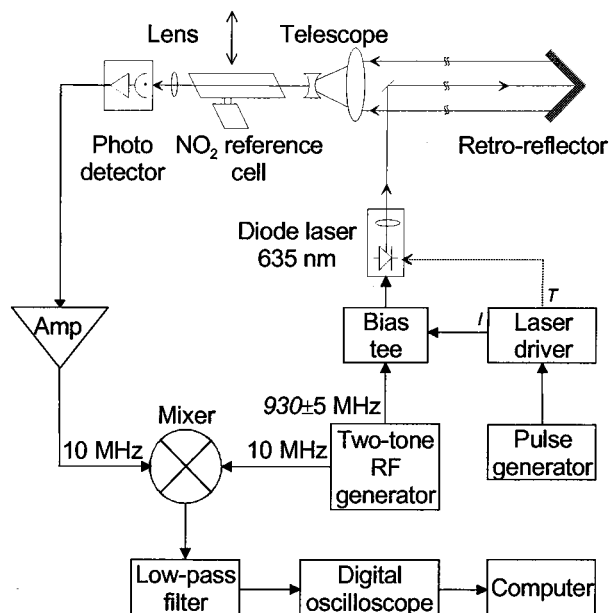

Fig. 1. Schematic diagram of the experimental setup for long-path measurements of NO_2 using high-frequency modulation spectroscopy.

most common methods to enhance measurement sensitivity use balanced detection^{9,10} or frequency-modulation techniques.^{6,12–15}

In the present work we reduce the noise bandwidth of the laser by employing a high-frequency modulation technique, namely, two-tone frequency-modulation spectroscopy^{16–18} (TTFMS). TTFMS using visible diode lasers is a convenient technique for sensitive trace-gas detection in that it combines high-speed, high-precision, zero-background, and remote-sensing capabilities, although modulation broadening is introduced at maximum sensitivity. At atmospheric pressure the absorption lines in NO_2 are broadened, and the modulation frequency must be correspondingly high. The modulation amplitude applied to the diode must also be increased compared to low-pressure measurements. The resulting line shapes resemble the second derivative, but are somewhat modified at atmospheric pressure because of overlapping lines.

2. Experimental

A schematic diagram of the experimental setup is shown in Fig. 1, with the long-path absorption arrangement shown in the upper part and the TTFMS electronics in the lower part. The tunable high-power diode laser used was an InGaAsP index-guided device manufactured by Hitachi (HL6320G). It has a nominal wavelength of 635 nm at 25 °C and a typical output power of 10 mW. Wavelength stability is ensured by controlling temperature and current of the laser diode with a precision diode-laser driver (Melles Griot 06DLD103). The temperature of the diode-laser capsule is stabilized to within 0.05 °C over one hour of measurement. An antireflection-coated molded glass aspheric lens (Geltech C240TM-B) collimates

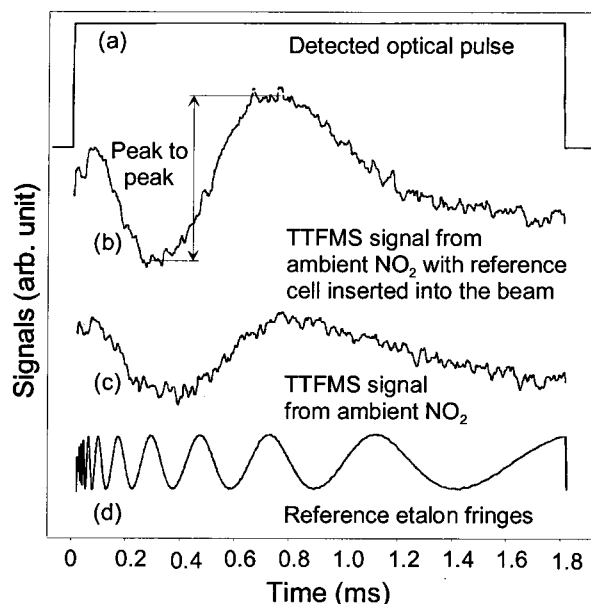

Fig. 2. Sensitive detection of NO_2 at atmospheric pressure: (a) detected optical pulse; (b) frequency-modulation signals from ambient NO_2 with the reference cell inserted into the beam, and (c) from atmospheric absorption. (d) Corresponding recording of the Fabry-Pérot etalon fringes (free spectral range 2.43 GHz) serving as a frequency scale.

the laser output. A small mirror directs the laser beam across a busy intersection about 5 m above the ground level until it hits a retroreflector. The back-reflected light is collected by a telescope with an aperture of 10 cm and is focused onto the detector that contains a p-i-n photodiode (Hamamatsu S-1190) and a homemade transimpedance amplifier. The beam can also be sent through two reference cells containing known concentrations of NO_2 that are used for calibration purposes. The windows of the cells are tilted to the Brewster angle to reduce spurious optical feedback.

Spectral scanning is achieved by applying a rectangular current pulse with a duration of 1–2 ms and a repetition rate of 250 Hz to the diode-laser drive current, which is biased below threshold. Thereby a longer wavelength scan is produced compared to a current ramp, and an almost constant frequency-modulation index during the scan is ensured.¹⁷ At the same time the sweep becomes highly nonlinear, as can be seen on the signals from a low-finesse glass etalon [Fig. 2(d)] used for frequency calibration of the absorption spectrum. The tuning range produced is approximately 25 GHz, sufficient to capture a single atmospheric pressure-broadened transition of NO_2 . A Burleigh WA-4500 wavemeter is used to measure the laser frequency and to verify single-mode operation of the diode laser.

The two-tone frequency-modulation setup used here is described thoroughly in some previous papers of our group.^{12,13,17–19} We have in this work used diode-laser modulation at 935 and 925 MHz with a signal demodulation at 10 MHz. The demodulated signal is amplified and low-pass filtered in a low-

noise preamplifier (Stanford SR560) that was set to 30 kHz, and subsequently averaged 256 times in a digital oscilloscope (Tektronix TDS520B), resulting in a total sampling time of 6 s. The TTFMS signal has a zero background, which is advantageous when the light intensity at the detector fluctuates due to atmospheric turbulence. The recorded waveforms are finally stored on floppy disks and transferred to a computer for postprocessing and evaluation.

3. Measurements and Results

Initially, measurements were performed to investigate the NO_2 absorption lines at different pressures. A reference cell was filled at 50 Torr with a calibration gas containing 0.2% NO_2 in high-purity synthetic air. A retroreflector was placed at a few meters distance. Survey spectra in the visible wavelength region around 635 nm were used to identify isolated lines for sensitive measurement. A strong absorption feature was selected by temperature tuning the diode laser, and this wavelength was used for NO_2 monitoring. The valve of the cell was then opened, and air was allowed slowly to enter. As the pressure increases, the absorption lines broaden with a corresponding decrease in the peak absorption. The TTFMS signal was maximized by significantly increasing the laser modulation index. At atmospheric pressure, the shape of the modulation signal is quite complex due to close-lying or overlapping absorption lines.

Atmospheric NO_2 measurements were performed using a round-trip path of 160 m. Interference from sparse oxygen and water lines in the probed spectral region was avoided by use of the HITRAN database.²⁰ This was also experimentally verified by inserting a cell filled with NO_2 into the beam in front of the detector, as shown in Fig. 1, and detecting an equivalent increase of the absorption feature that necessarily pertains to NO_2 . Vanishing frequency-modulation signals were recorded at times with low traffic intensity. The minimum detectable concentration is estimated using the reference cell containing NO_2 at atmospheric pressure. The peak-to-peak value of the recorded TTFMS signal [Figs. 2(b), 2(c)] is related to the absorption and also scales linearly with the power at the detector [Fig. 2(a)]. The detection limit for the system corresponding to a signal-to-noise ratio $S/N = 1$ is found to be about $10 \mu\text{g}/\text{m}^3$ in a 160 m path and with a 256 times averaging. The main noise sources under monitoring conditions were the light-intensity fluctuations, the detector noise, and the residual optical interference. Using a long-path configuration for ambient NO_2 detection, we have not observed significant etalon fringes, which usually limit the minimum detectable absorption when short optical paths or multipass cells are employed.

Figure 3 shows a data set of the measured NO_2 concentration in air along the 160 m round-trip path. The data points were acquired sequentially every minute. The wind strength and direction constitute

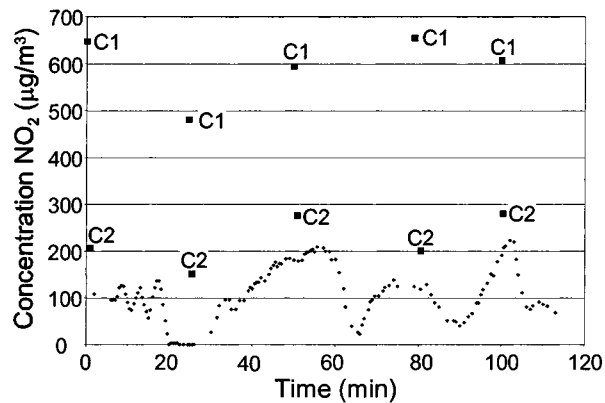

Fig. 3. Time recording of the measured concentrations of NO_2 along a 160 m long path over a road intersection during winter hours at peak traffic. C1 and C2 mark two reference cells containing an equivalent of $470 \mu\text{g}/\text{m}^3$ and $87 \mu\text{g}/\text{m}^3$ of NO_2 , respectively, inserted into the beam for calibration purposes.

important parameters because the measurements are performed 5 m above the pollution sources, i.e., the exhaust pipes of the passing cars. At the time of the measurement there were calm wind conditions. Two reference cells of the type discussed above, 30 and 5.6 cm long, respectively, were inserted into the beam for calibration (standard addition method). They contained 0.013% NO_2 at atmospheric pressure corresponding to an equivalent of 470 and $87 \mu\text{g}/\text{m}^3$, respectively, of NO_2 uniformly spread over the 160 m path. We did not observe any direct increase of the signal after the passage of most of the individual cars because the beam passed too high above the exhaust pipes. However, at some occasions a high NO_2 emission was detected after the passage of some diesel trucks and buses.

4. Discussion

It can be seen from the graph in Fig. 3 that the span between the long-path concentrations measured directly and the values that can be derived from the almost simultaneous calibrations is changing somewhat from calibration to calibration. This variation can be explained by residual etalon fringes generated by the windows of the reference cells when these are introduced into the beam at calibration. It adds a random contribution to the detected gas signal and limits the accuracy of the calibration. By antireflection coating the cell windows, the effect is expected to decrease.

Comparison of the measured NO_2 sensitivity to other works shows that the detection limit is good, although the sensitivity at atmospheric pressure is reduced due to smaller peak absorption. In the equivalent remote-sensing measurements presented in Ref. 5 the estimated noise level was $0.5 \text{ ppm}\cdot\text{m}$ over an 88 m path, corresponding to an average concentration of $11 \mu\text{g}/\text{m}^3$ for $S/N = 1$. The relatively high NO_2 concentrations obtained in this study are explained by the intense traffic during the measurements, averaging 70 vehicles in 5 minutes. Light-

intensity variations in the time range of several minutes appear to be caused mainly by thermal drifts in the optical alignment, because the optical power could be recovered by realignment. Longer absorption paths would be possible by using a better telescope in order to collect more light, thereby lowering the detection limit. Higher diode-laser output powers are available at a wavelength of 670 nm. An additional advantage for operating at wavelengths near 670 nm is that interference with water absorption lines can be completely avoided.¹⁰ Additionally, NO₂ presents larger absorption lines in the blue region, and it is likely that the sensitivity could be further increased using blue diode lasers in remote absorption measurements.^{21,22} Unfortunately, presently available blue diode lasers typically operate on several modes and need to be assembled in external-cavity arrangements that reduce the available output power considerably.

5. Conclusions

We have demonstrated the possibility to use diode-laser-based spectroscopic detection for long-path NO₂ concentration measurements in urban air. The performance is comparable to that of a differential optical absorption spectroscopy system, where the wavelength region around 450 nm is scanned over tens of nanometers, thereby revealing larger absorption structures. In our case the TTFMS technique is used to increase the sensitivity for measurements of small absorption levels. The achieved detection sensitivity of 10 μg/m³ in a 160 m path at atmospheric pressure is lower than for low pressure NO₂ due to the decrease of peak absorption at atmospheric pressure.

In the present work the sensor is operated as a semiportable device. Further development of this diode-laser-based trace-gas detector into a compact, fully portable field instrument should find many applications in pollution monitoring measurements.

This work was supported by the Swedish Research Council for Engineering Sciences (TFR) and the Knut and Alice Wallenberg Foundation. J. Alnis would like to thank the Swedish Institute for a stipend supporting his stay in Sweden.

References

- U. Platt, "Differential optical absorption spectroscopy (DOAS)," in *Air Monitoring by Spectroscopic Techniques*, M. W. Sigrist, ed., Vol. 127 of Chemical Physics Series (Wiley, New York, 1994), pp. 27–84.
- H. Edner, P. Ragnarson, S. Spännare, and S. Svanberg, "Differential optical absorption spectroscopy (DOAS) system for urban atmospheric pollution monitoring," *Appl. Opt.* **32**, 327–333 (1993).
- K. A. Fredriksson and H. M. Hertz, "Evaluation of the DIAL technique for studies on NO₂ using a mobile lidar system," *Appl. Opt.* **23**, 1403–1411 (1984).
- H. Edner, P. Ragnarson, and E. Wallinder, "Industrial emission control using lidar techniques," *Environ. Sci. Technol.* **29**, 330–337 (1995).
- J. L. Jimenez, G. J. McRae, D. D. Nelson, M. S. Zahniser, and C. E. Kolb, "Remote sensing of NO and NO₂ emissions from heavy-duty diesel trucks using tunable diode lasers," *Environ. Sci. Technol.* **34**, 2380–2387 (2000).
- J. Reid, M. El-Sherbiny, B. K. Garside, and E. A. Ballik, "Sensitivity limits of a tunable diode laser spectrometer, with application to the detection of NO₂ at the 100-ppt level," *Appl. Opt.* **19**, 3349–3354 (1980).
- W. Lenth and M. Gehrtz, "Sensitive detection of NO₂ using high-frequency heterodyne spectroscopy with GaAlAs diode laser," *Appl. Phys. Lett.* **47**, 1263–1265 (1985).
- C. R. Webster, R. D. May, C. A. Trimble, R. G. Chave, and J. Kendall, "Aircraft (ER-2) laser infrared absorption spectrometer (ALIAS) for in-situ stratospheric measurements of HCl, N₂O, CH₄, NO₂, and HNO₃," *Appl. Opt.* **33**, 454–472 (1994).
- M. G. Allen, K. L. Carleton, S. J. Davis, W. J. Kessler, C. E. Otis, D. A. Palombo, and D. M. Sonnenfroh, "Ultrasensitive dual-beam absorption and gain spectroscopy: applications for near-infrared and visible diode laser sensors," *Appl. Opt.* **34**, 3240–3249 (1995).
- D. M. Sonnenfroh and M. G. Allen, "Ultrasensitive, visible tunable diode laser detection of NO₂," *Appl. Opt.* **35**, 4053–4058 (1996).
- R. M. Mihalcea, D. S. Baer, R. K. Hanson, "Tunable diode-laser absorption measurements of NO₂ near 670 and 395 nm," *Appl. Opt.* **35**, 4059–4064 (1996).
- P. Kauranen, H. M. Hertz, and S. Svanberg, "Tomographic imaging of fluid flows by the use of two-tone frequency-modulation spectroscopy," *Opt. Lett.* **19**, 1489–1491 (1994).
- P. Kauranen, I. Harwigsson, and B. Jönsson, "Relative vapor pressure measurements using a frequency-modulated tunable diode laser, a tool for water activity determination in solutions," *J. Phys. Chem.* **98**, 1411–1415 (1994).
- H. Riris, C. L. Carlisle, L. W. Carr, D. E. Cooper, R. U. Martinelli, and R. J. Menna, "Design of an open path near-infrared diode laser sensor: application to oxygen, water, and carbon dioxide vapor detection," *Appl. Opt.* **33**, 7059–7066 (1994).
- T. J. Johnson, F. G. Wienhold, J. P. Burrows, and G. W. Harris, "Frequency modulation spectroscopy at 1.3 μm using InGaAsP lasers: a prototype field instrument for atmospheric chemistry research," *Appl. Opt.* **30**, 407–413 (1991).
- D. E. Cooper and T. F. Gallagher, "Double frequency modulation spectroscopy: high modulation frequency with low-bandwidth detectors," *Appl. Opt.* **24**, 1327–1334 (1985).
- V. G. Avetisov and P. Kauranen, "High-resolution absorption measurements using two-tone frequency modulation spectroscopy with diode lasers," *Appl. Opt.* **36**, 4043–4054 (1997).
- V. G. Avetisov and P. Kauranen, "Two-tone frequency-modulation spectroscopy for quantitative measurements of gaseous species: theoretical, numerical and experimental investigation of lineshapes," *Appl. Opt.* **35**, 4705–4723 (1996).
- U. Gustafsson, G. Somesfalean, J. Alnis, and S. Svanberg, "Frequency modulation spectroscopy with blue diode lasers," *Appl. Opt.* **39**, 3774–3780 (2000).
- L. S. Rothman, C. P. Rinsland, A. Goldman, S. T. Massie, D. P. Edwards, J.-M. Flaud, A. Perrin, C. Camy-Peyret, V. Dana, J.-Y. Mandin, J. Schroeder, A. McCann, R. R. Gamache, R. B. Wattson, K. Yoshino, K. V. Chance, K. W. Jucks, L. R. Brown, V. Nemtchinov, and P. Varanasi, "The HITRAN molecular spectroscopic database and HAWKS (HITRAN Atmospheric Workstation): 1996 edition," *J. Quant. Spectrosc. Radiat. Transfer* **60**, 665–710 (1998).
- J. T. C. Liu, R. K. Hanson, and J. B. Jeffries, "High-sensitivity absorption diagnostic for NO₂ using a blue diode laser," *J. Quant. Spectrosc. Radiat. Transfer* **72**, 655–664 (2002).
- M. I. Mazurenka, B. L. Fawcett, J. M. F. Elks, D. E. Schallcross, and A. J. Orr-Ewing, "410-nm diode laser cavity ring-down spectroscopy for trace detection of NO₂," *Chem. Phys. Lett.* **367**, 1–9 (2003).