



LUND UNIVERSITY

A numerical investigation of heat transfer enhancement in offset strip fin heat exchangers in self-sustained oscillatory flows

Saidi, Arash; Sundén, Bengt

Published in:

International Journal of Numerical Methods for Heat & Fluid Flow

DOI:

[10.1108/EUM0000000005984](https://doi.org/10.1108/EUM0000000005984)

2001

[Link to publication](#)

Citation for published version (APA):

Saidi, A., & Sundén, B. (2001). A numerical investigation of heat transfer enhancement in offset strip fin heat exchangers in self-sustained oscillatory flows. *International Journal of Numerical Methods for Heat & Fluid Flow*, 11(7), 699-716. <https://doi.org/10.1108/EUM0000000005984>

Total number of authors:

2

General rights

Unless other specific re-use rights are stated the following general rights apply:

Copyright and moral rights for the publications made accessible in the public portal are retained by the authors and/or other copyright owners and it is a condition of accessing publications that users recognise and abide by the legal requirements associated with these rights.

- Users may download and print one copy of any publication from the public portal for the purpose of private study or research.
- You may not further distribute the material or use it for any profit-making activity or commercial gain
- You may freely distribute the URL identifying the publication in the public portal

Read more about Creative commons licenses: <https://creativecommons.org/licenses/>

Take down policy

If you believe that this document breaches copyright please contact us providing details, and we will remove access to the work immediately and investigate your claim.

LUND UNIVERSITY

PO Box 117
221 00 Lund
+46 46-222 00 00



A numerical investigation of heat transfer enhancement in offset strip fin heat exchangers in self-sustained oscillatory flows

Heat transfer
enhancement

699

Received February 2001

Revised June 2001

Accepted June 2001

Arash Saidi and Bengt Sundén

Division of Heat Transfer, Lund Institute of Technology, Lund, Sweden

Keywords *Fins, Heat transfer, Computational methods*

Abstract *Numerical analysis of the instantaneous flow and heat transfer has been carried out for offset strip fin geometries in self-sustained oscillatory flow. The analysis is based on the two-dimensional solution of the governing equations of the fluid flow and heat transfer with the aid of appropriate computational fluid dynamics methods. Unsteady calculations have been carried out. The obtained time-dependent results are compared with previous numerical and experimental results in terms of mean values, as well as oscillation characteristics. The mechanisms of heat transfer enhancement are discussed and it has been shown that the fluctuating temperature and velocity second moments exhibit non-zero values over the fins. The creation processes of the temperature and velocity fluctuations have been studied and the dissimilarity between these has been proved.*

Nomenclature

b	= Fin thickness	Re	= Reynolds number
d_h	= Hydraulic diameter	s	= Fin transverse spacing
f	= Fanning friction factor	S_t	= Strouhal number
f_{os}	= Oscillation frequency	T	= Mean temperature
\bar{h}	= Mean heat transfer coefficient	t	= Fluctuating part of temperature
h	= fin height	U_c	= Mean velocity in the minimum area
j	= Colburn factor	U_i	= Mean velocity components ($i = 1,2,3$)
l	= Fin length	U_m	= Mean velocity
L_m	= The length of calculation module	u_i	= Fluctuating part of velocity components ($i = 1,2,3$)
Nu	= Nusselt number	ν	= Kinematic viscosity
P	= Pressure	ρ	= Density
Pr	= Prandtl number		

Introduction

The introduction of compact heat exchangers in gas turbine cycles is increasing. One of the applications is intercooling (combined with recuperators) to achieve higher levels of thermal efficiency. The most common way of intercooling is to use a gas-to-liquid compact heat exchanger (Saidi *et al.*, 2000). By definition a compact heat exchanger is one which incorporates a heat transfer surface with an area density (or compactness) above $700\text{m}^2/\text{m}^3$ on at least one of the fluid sides which usually is the gas side (Shah *et al.*, 1998). In order to increase the

Financial support from the Swedish Energy Administration (STEM) is kindly acknowledged.

compactness of an intercooler it is necessary to consider closely the types of extended surfaces being suitable. The dominating part of the thermal resistance for liquid-to-gas heat exchangers occurs on the gas (or air) side and thus it is worthwhile to focus attention on different types of fins for the air-side. There are many types of extended surface concepts that can be used or are being used in intercoolers. As an example, the extended surface type called offset strip fin geometry (Joshi and Webb, 1987) is presented in Figure 1. This geometry is very common. It provides high heat transfer area per unit volume and high Nu numbers. The heat transfer enhancement mechanism is through interruption of laminar boundary layers on the fins and self-sustained oscillatory flows at higher Re numbers. In Figure 1 the geometrical parameters of an offset strip fin arrangement are shown. These parameters are l , s , b and h , namely, fin length, fin transverse spacing, fin thickness and fin height.

Jacobi and Shah (1996) describe the flow characteristics in such fins. At Reynolds (Re) numbers less than 400, the flow is laminar and steady and the boundary layer dominates the heat transfer process. At intermediate Re numbers, 400-1,000, the flow remains laminar, but unsteadiness and vortex shedding tend to dominate. At Re numbers above 1,000, the flow becomes turbulent. A more detailed study of the flow transition, including effects of geometrical parameters, has been presented in Joshi and Webb (1987), and an experimental correlation for prediction of the transition Re number was suggested. The j and f correlations are also suggested for laminar and turbulent ranges but the self-sustained oscillatory flow range is not included in the correlations. There are also other experimental investigations. These works report different correlations for heat transfer and pressure drop. The first analytical effort by Kays (1972) gave a modified laminar boundary layer solution. Power-law fitted correlations were presented by Wieting (1975) for 22 geometries, for Re numbers of laminar and turbulent ranges, excluding the intermediate Re numbers. Most recently, Manglik and Bergles (1995) re-analyzed the existing empirical data for actual cores and suggested design correlations for heat transfer and friction factor in the form of single continuous expressions covering all flow regimes. Once again, their correlations exclude the intermediate Re numbers.

Numerical investigations on the subject are also available. Sparrow *et al.* (1977) investigated a case with zero fin thickness. They did not capture the

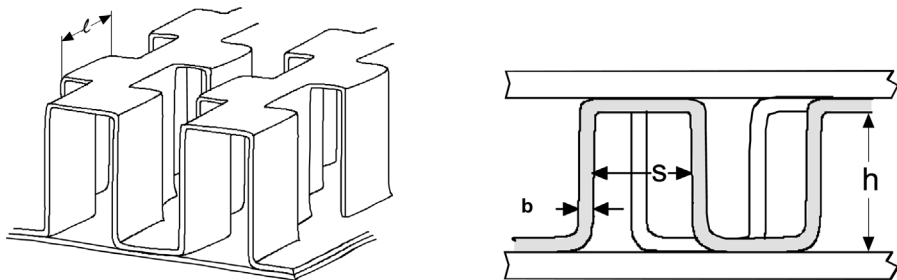

Figure 1.
Offset strip fin geometry

impingement in front of the fin and the recirculation downstream of it due to the zero thickness assumption for the fins. Patankar and Prakash (1981) investigated the effect of fin thickness on the flow field and heat transfer. They concluded that, even though thicker fins result in higher pressure drops, the heat transfer does not improve significantly. Suzuki *et al.* (1982) carried out a numerical investigation for mixed convection in laminar flow through staggered arrays of zero thickness offset strip fins. That investigation has been extended to finite thickness of the fins by Suzuki *et al.* (1985). Xi *et al.* (1992) carried out numerical computations for the range of Re numbers (low values), where the flow remained steady and laminar, and it was observed that the flow instability in the wake of the fin is effective to enhance the heat transfer downstream of the fin as well. Two-dimensional numerical computations for a periodically changing unsteady flow regime or so-called second laminar flow regime have been carried out (Suzuki *et al.*, 1994; Xi *et al.*, 1995). This regime is characterized by self-sustained flow oscillations. These and other studies have presented interesting and detailed investigations of the oscillating temperature and flow fields and obtained results showing the enhancement mechanisms due to the unsteady character of the flow. A detailed analysis of the heat and momentum transport in a periodic series of fins in a communicating duct using periodicity assumption was carried out by Majumdar and Amon (1992). They studied the transport phenomena due to oscillations in temperature and velocity fields.

Mercier and Tochon (1997) have carried out a two-dimensional time dependent analysis in the turbulent flow regime. Owing to limitations of computer capabilities all of the turbulent scales could not be resolved in their computations and the computational method was referred to as a pseudo-direct numerical simulation. Two recent and related investigations are those of Zhang *et al.* (1997) and DeJong *et al.* (1998). They showed that inclusion of flow unsteadiness plays a very important role in the accurate prediction of heat transfer. They also verified the fact that a two-dimensional unsteady numerical simulation captures the important features of the flow and heat transfer for a range of conditions.

The present investigation focuses attention on the intermediate Re numbers at which the majority of experimental investigations do not provide correlations. The interesting phenomenon of dissimilarity of heat transfer and momentum transport with respect to heat transfer enhancement is studied for the case of offset strip fin arrays. Such a phenomenon has been studied for other geometries like a series of single fins by Xi *et al.* (1995), Suzuki *et al.* (1994), and for a periodic series of fins in a communicating channel by Majumdar and Amon (1992). Although similar studies have been carried out but not for the case of an offset strip fin geometry, which is the geometry in this investigation, one objective is to improve the understanding of the enhancement mechanism in this particular geometry. It is not obvious that the results of the former studies on different geometries are applicable to this specific geometry. It is also worth mentioning that the considered geometry in

contrast with those studied in the past is a practical extended surface application. DeJong *et al.* (1998) studied this case but they did not pay attention to the detailed mechanisms of the heat and momentum transfer processes.

Taking these points into consideration, it is clear that the current study is unique in dealing with the character of heat transfer enhancement mechanism in offset strip fin geometries. The results of this study will show that the enhancement mechanism in a certain Re number range is special and also it will prove the dissimilarity between the two processes of heat transfer and momentum transfer in that certain range of Re numbers. It is also worth mentioning that the overall goal of this study is not to present new numerical methods or verify any numerical scheme, but instead to reveal the physical phenomena and the related implications for the heat transfer mechanism. Thus an established finite volume method is used in the computational analysis.

Assumptions and method of analysis

Possible methods of comparison and evaluation of different geometrical concepts of extended surfaces have been presented by Shah *et al.* (1998). Investigations of the thermal performance of various extended surface geometries are commonly experimental but rapid developments of computer capacity and numerical solution methods have implied that a theoretical analysis is reliable in many cases. So-called CFD-methods (computational fluid dynamics) (see, for example, Veersted and Malalasekera (1995)) may offer a cheaper and more flexible tool, as a variety of extended surfaces or fins is to be analyzed. Such methods will give the opportunity for testing new concepts before experimentation that can be expensive and troublesome. In this report four different extended surfaces are considered.

The computational domain is limited to a basic module shown in Figure 2. This simplification is based on the assumption of fully developed flow and thermal fields in the array of fins. Two pairs of periodic boundaries in the longitudinal and transverse directions limit the module. Experimental investigations (DeJong *et al.*, 1998; Joshi and Webb, 1987), justify these assumptions.

The two-dimensional continuity, Navier-Stokes and energy equations are solved:

$$\frac{\partial u_i}{\partial x_i} = 0 \quad (1)$$

$$\frac{\partial u_i}{\partial \tau} + \frac{\partial}{\partial x_j} (u_i u_j) = -\frac{1}{\rho} \frac{\partial p}{\partial x_i} + \nu \frac{\partial^2 u_i}{\partial x_j \partial x_j} \quad (2)$$

$$\frac{\partial T}{\partial \tau} + \frac{\partial}{\partial x_j} (T u_j) = \frac{\nu}{Pr} \frac{\partial^2 T}{\partial x_j \partial x_j} \quad (3)$$

The flow is assumed to be incompressible with constant properties. Buoyancy forces and viscous dissipation are not considered. Periodic boundary conditions

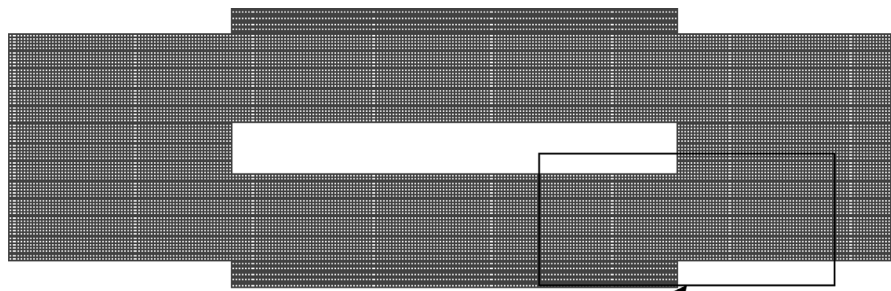

Heat transfer
enhancement

703

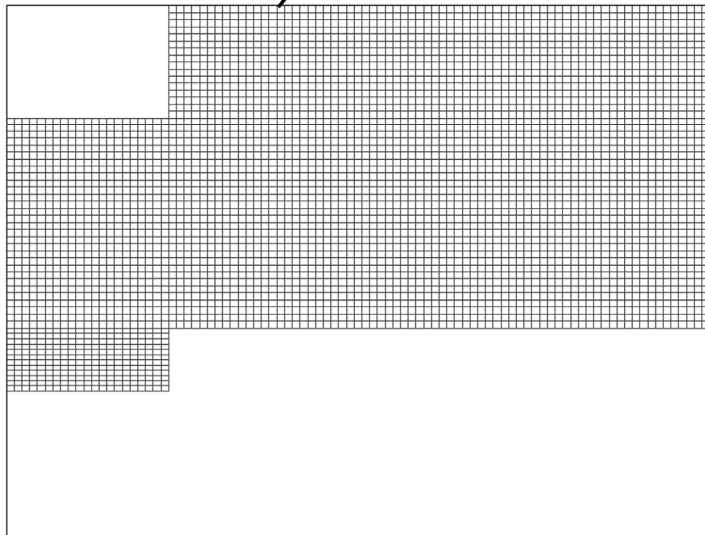

Figure 2.
The grid used for the
calculations

have been applied at the inlet and outlet sections, and in the transverse direction. The wall boundary conditions are no-slip for the momentum equations and constant heat flux for the energy equation.

A finite volume multi-block method has been applied. In this case an available general purpose CFD-code (STAR-CD) has been applied to solve the resulting governing algebraic equations. In previous works, this code has been found to perform well if applied with care. The QUICK scheme is used to

handle convective-diffusive terms. The PISO algorithm is used for treating the coupling of the pressure and velocity fields. The Crank-Nicolson method is used for time discretization. The maximum residual tolerance of all equations has been kept at less than 10^{-6} and the maximum value of the Courant number for all Re numbers was about unity.

A multi-block calculation has been carried out, with six blocks. The number of grid points in the calculations varied from 162×40 to 270×62 (Figure 2). Further refinement to 324×75 grid points changed the results of the friction factor and Nu numbers by less than 1 percent. The computer used to carry out the calculations was a Digital AlphaStation[®] 255 (with CPU clock rate of 233MHz) and the CPU time required for the calculations was 0.001857 sec per time step and mesh point. The time step of the calculations is chosen in order to achieve the correct time resolution, so that there are a sufficient number of time steps to capture all the oscillations. As a result CFL (Courant) numbers of a maximum value around unity in the whole domain were proved.

The Re number for the flow is defined as:

$$\text{Re} = U_c d_h / \nu \quad (4)$$

U_c is the velocity at the minimum flow area and d_h is the hydraulic diameter, which is defined as:

$$d_h = 2(s - b)l / (l + b) \quad (5)$$

The pressure drop has been related to the Fanning friction factor,

$$f = \frac{2\Delta P}{\rho U_c^2} \left(\frac{d_h}{4L_m} \right) \quad (6)$$

and the average heat transfer coefficient is presented in terms of the Colburn j factor:

$$j = \frac{\overline{\text{Nu}}}{\text{Re} \text{Pr}^{1/3}} = \frac{\overline{h} \text{Pr}^{2/3}}{\rho c_p U_m} \quad (7)$$

Results

The case study in this investigation is an offset strip fin geometry, shown in Figure 3, with the geometrical dimensions given in Table I. These dimensions are identical to those in a previous investigation (DeJong *et al.*, 1998), and the overall computed results are compared with the numerical results of that study. The focus point of this study, as has already been mentioned, has been different from their investigation and attention is paid to the mechanisms of heat transfer enhancement.

The results are presented in three sections. In the first section the time averaged mean values of heat transfer and fluid flow properties, friction factor and Colburn j factor, are presented. The second section includes the time-

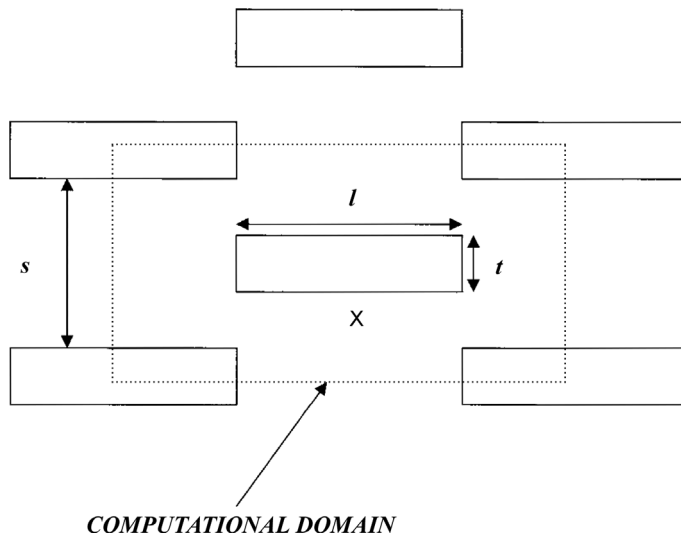

Figure 3.
Basic module and
computational domain

Parameter	Value
b/l	0.117
s/l	0.507
l	24mm

Table I.
Dimensions of the
offset strip fin
geometry

dependent features of the flow simulation. In this part the time-dependent velocity field is presented. The oscillatory velocity history at a point is depicted and the dominating frequency of the oscillatory flow is determined and the non-dimensional oscillation similarity of the flow for a range of Re numbers is discussed. In the last section, the time-averaged second moments of the velocity and temperature fields are presented. The corresponding production terms of velocity and temperature fluctuations are provided and discussed.

Time-averaged mean values

The friction factor results compared with the results of DeJong *et al.* (1998) are provided in Figure 4. The calculated friction factors of this study are under-predicted (14-16 percent) compared with those of DeJong *et al.* (1998). The Colburn j factor results are compared with corresponding results of that investigation in Figure 5(a). The deviations between the results of this study and those of DeJong *et al.* (1998) are in the range of 6-8 percent. These comparisons show that the present numerical simulation method is able to satisfactorily reproduce the results obtained for the same geometry by DeJong *et al.* (1998) in terms of time-averaged mean values. It should thus be reasonable to interpret the time-dependent characteristics of the flow and temperature fields.

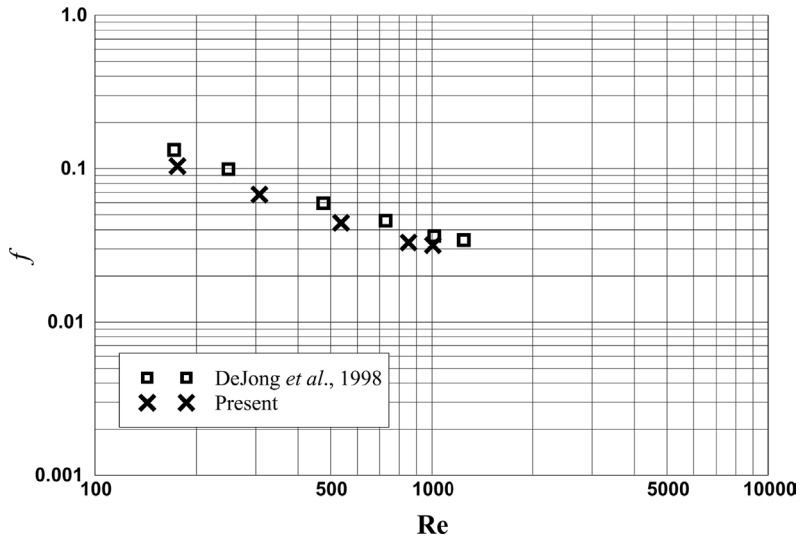

Figure 4.
Comparison of friction factor results

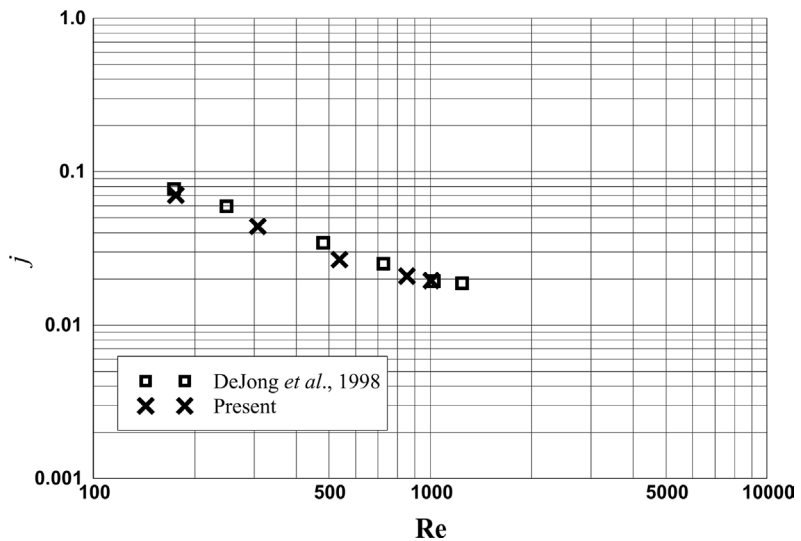
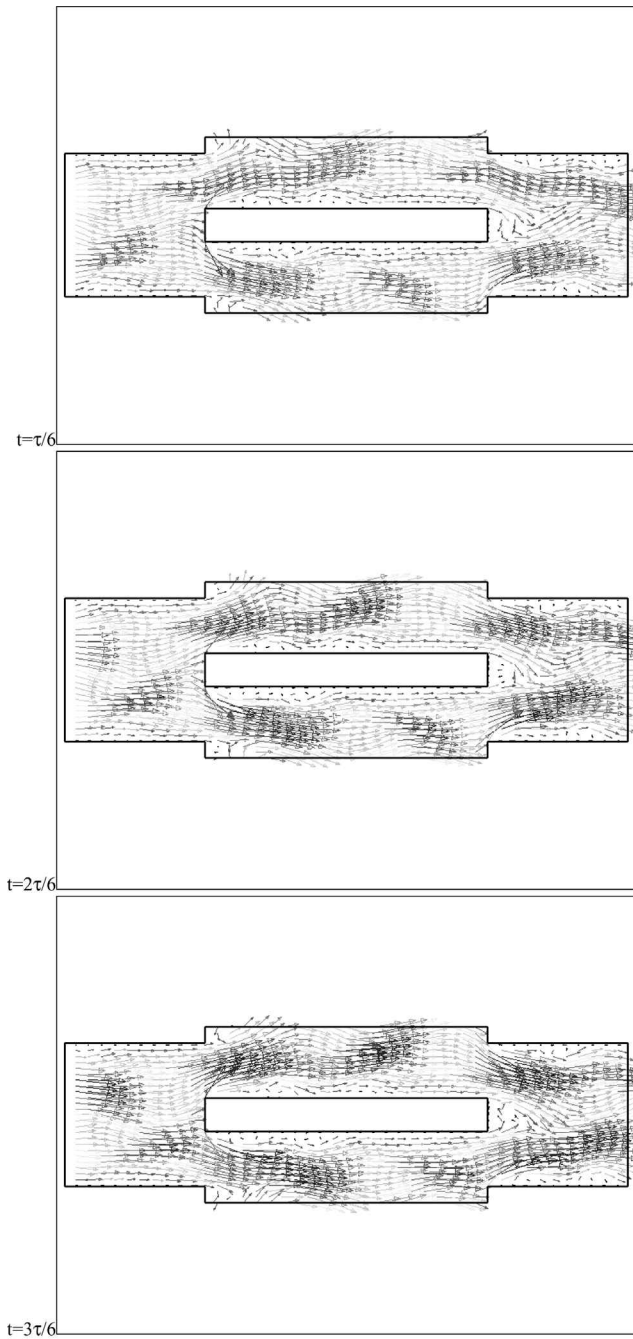

Figure 5.
Comparison of Colburn j factor results

If one considers the ratio j/f , it is found that a maximum appears around $Re = 900-1,000$. The reason for this might be that laminar self-oscillating flow occurs and the benefit in overall performance is believed to be caused by dissimilarity between the mechanism for momentum and heat transfer. A more detailed discussion will follow.

Unsteady velocity field description

Figure 6 shows the velocity field around the fin during a complete period of oscillations. This Figure shows the development of the flow in form of the time-



(Continued)

Figure 6.
Velocity vectors over a
period of oscillations

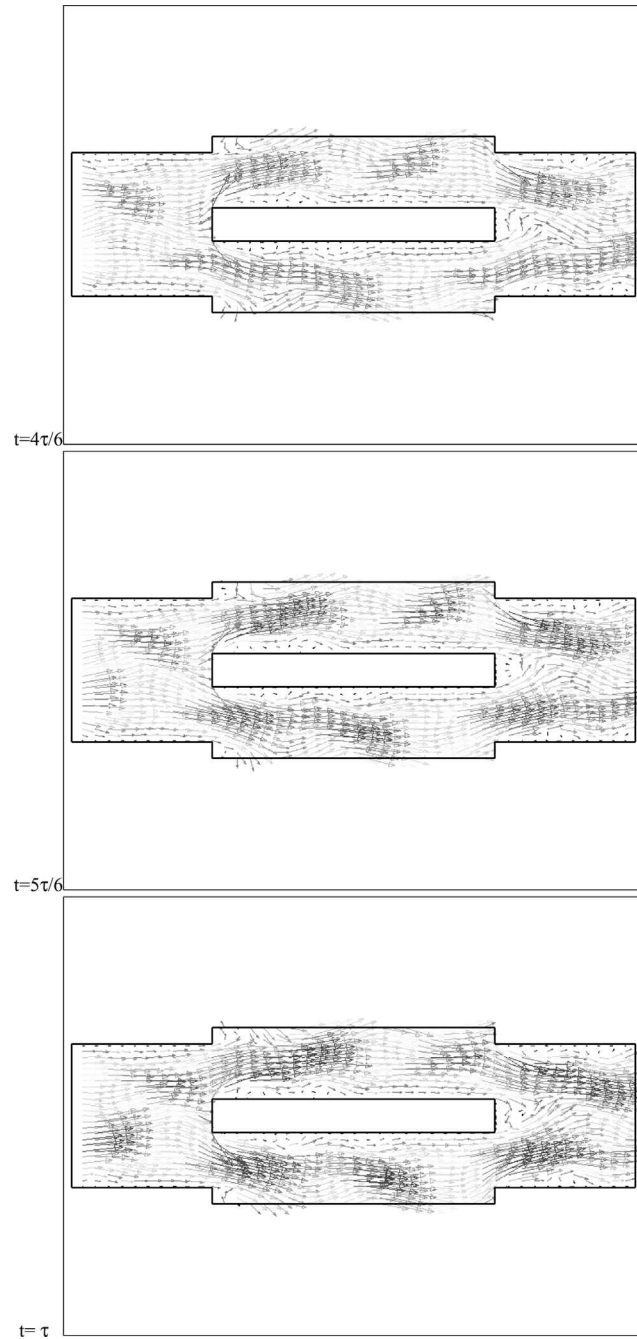

Figure 6.

dependent velocity vectors in a series of six time steps during this period (at $Re = 993$). The flow structure shows a wavy-oscillatory pattern. This Figure and the flow pattern show that at this Re number the flow has become unsteady. The wavy pattern shows that the flow between fins is not bounded in the channel type area just downstream of the fin, the so-called “communicating” region, as has also been observed in other studies, for example, Majumdar and Amon (1992). As is obvious, the flow is bouncing up and down out of this area and promoting the mixing process between the area downstream of the fin and the air in the vicinity of the upper fin.

The structure of the flow field over the fin needs consideration as well. In contrast with a simple boundary layer type pattern over the fin, there are certain kinds of circulation bubbles over the fin, two of which are readily observed. These bubbles are commuting over the fin during the period of oscillation and over a certain finite length of the fin. At $t = \tau/6$, they are at the upstream part of the fin, they move further downstream and the second circulation bubble (or vortex) is absorbed in the main flow stream at $t = 4\tau/6$. However, another pair is built up already at $t = 5\tau/6$, and the cycle continues.

The velocity time history at point X (Figure 2) is depicted in Figure 7. It is obviously a very orderly time variation that suggests a pure oscillatory motion that is not chaotic. A way to highlight this point even more is to look at the fast Fourier transformation (FFT) of this time history (Figure 8). This transformation to frequency shows a very strong oscillation frequency at $f_s = 68\text{Hz}$. With the Strouhal number based on the transverse dimension of the fin, its thickness (b) is defined as

$$St = \frac{f_s b}{U_c}$$

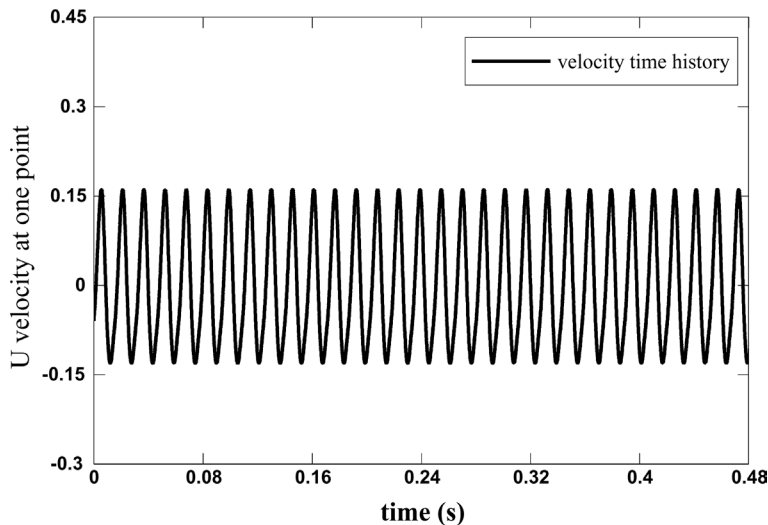
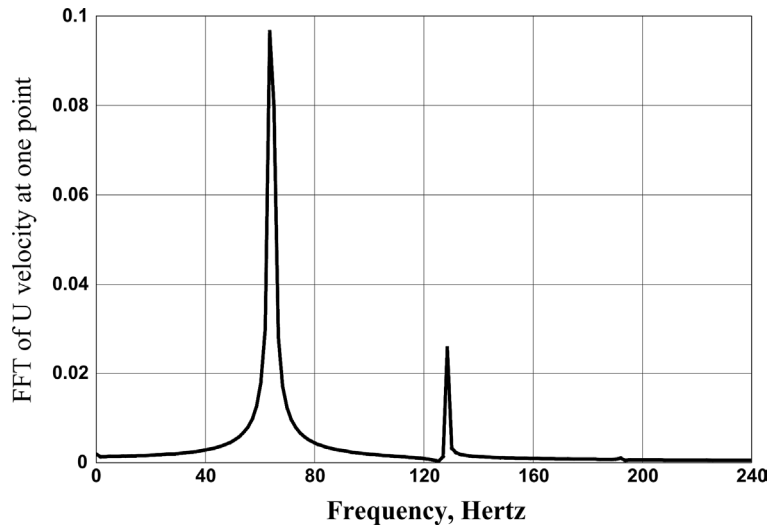

Figure 7.
Time history of velocity
at point X, $Re = 1,124$

HFF
11,7

710

Figure 8.
FFT of the time history
of velocity at point X,
 $Re = 1,124$



and is equal to 0.2. This value is equal to the experimentally reported value of Strouhal number for a staggered tube bank with the same transverse dimension (Fitz-Hugh, 1973). It is also worth mentioning that this frequency dominates the whole flow structure, and the whole flow pattern is repeated with the same frequency (the time period shown in Figure 6 is identical to the inverse of this frequency).

Second moments of velocity and temperature and their interpretation

The time-averaged U-velocity and temperature contours are presented in Figure 9. Despite the fluctuating character of the unsteady flow field, the time-averaged patterns of velocity and temperature fields are symmetrical. Highest velocities occur in the contraction area between fins. Considering the unsteady flow behavior, no boundary layer type flow can be found but in the time-averaged flow picture it is found and can be seen in Figure 9(a). This boundary layer forms over the fin and thickens downstream. A somewhat thinner thermal boundary layer also exists in the time-averaged structure, as seen in Figure 9(b). The higher temperature levels are found over the fin inside this boundary layer and just downstream of the fin.

Figure 9(a) shows the contour plot of the second moment correlation between the two fluctuating velocity components, \overline{uv} . This corresponds to a Reynolds shear stress component in a turbulent flow. Although the flow is not turbulent and shows quite regular oscillatory behavior (Figures 7 and 8), non-zero values of \overline{uv} exist everywhere in the flow field. As expected, the values show an anti-symmetrical pattern as well. It is interesting to analyze the distribution of the second moment of the velocity fluctuations. Two different parts of the flow field in Figure 9(a) can be recognized. One is the flow area over the fin surface, and the second one is the area downstream of the fin. As can be seen, the maximum spots of the fluctuating moment occur in the flow area downstream

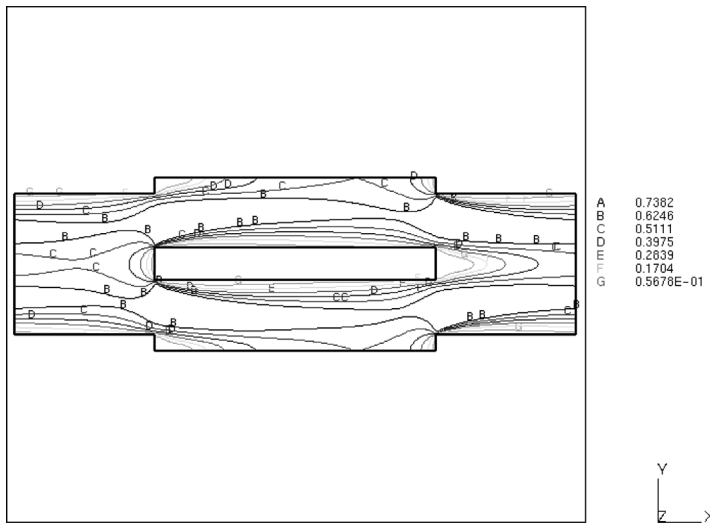

(a)

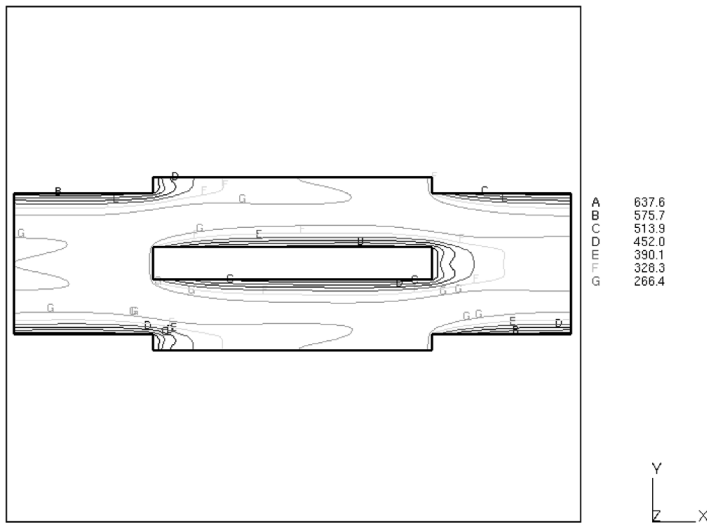

(b)

Figure 9.
Time-averaged
U-velocity (a) and
temperature contours (b)

of the fin, while the values over the fin surface are considerably lower. This suggests that the main production of these moments, and the mixing process of the momentum due to fluctuations, take place in the wake of the fin, and not in the boundary layer over the fin surface.

The second moment of the temperature-velocity fluctuations \overline{vt} is shown in Figure 10(b). The distribution of this second moment shows a similar pattern to the previous one, but there is a major difference as well. The hot spots

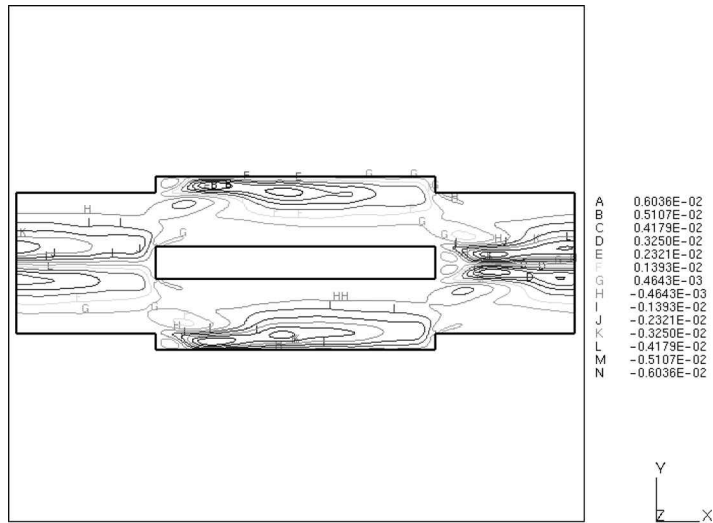

(a)

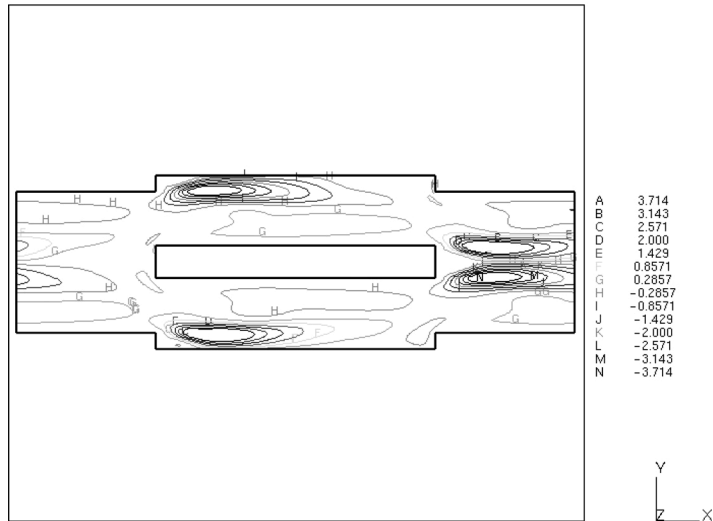

(b)

Figure 10.
Second moment
correlation of velocity
components \overline{uv} contour
(a), temperature
fluctuations moment \overline{vT}
contour (b)

downstream of the fin are found in this Figure as well, and in a very similar way. This suggests that the mixing process due to velocity-temperature fluctuations occurs in this region. The heat transfer process is then enhanced. The difference is on the area over the fin surface. In contrast with the second moment of the velocity fluctuations there is a kernel of positive values of \overline{vT} over the fin surface that is not convected from the upstream part, as it is not

clearly attached to the contours upstream. This means that the production of $\overline{v't}$ takes place over the fin surface as well.

The above mentioned observations and reflections suggest a certain dissimilarity between the process of momentum transfer and the heat transfer process. To make this discussion even clearer one may consider the production terms for velocity and temperature fluctuations. The production of the fluctuating kinetic energy is equal to:

$$P_k = -\overline{u_i u_j} \frac{\partial U_i}{\partial x_j} \quad (8)$$

This value is calculated and depicted in Figure 11(a). The positive values of this term show the regions where the mixing process will promote the momentum transfer. This Figure shows that positive production occurs only downstream of the fin in the area where the fluctuations exist. A small hot spot of positive production exists in the corner of the fin at the leading edge. The whole boundary layer area over the fin shows a negative production of kinetic energy, which means that the mixing of the momentum in this area will be damped. Obviously there is a clear contradiction to the mechanism in a turbulent boundary layer, where the bursting process in the near wall region provides the production of kinetic energy. Now attention will be paid to the production of the temperature variance (similar to fluctuating kinetic energy). This production is given by:

$$P_{tt} = -\overline{u_j t} \frac{\partial T}{\partial x_j} \quad (9)$$

Two hot spots of production are observed downstream of the fin in Figure 11(b). These are related to the same fluctuations that cause the momentum mixing in the same area. However, in contrast with what was observed in the previous production plot, the values over the fin surface area are not solely negative and an area of positive production of temperature fluctuations is observed here. This positive area is generated locally and is convected downstream and strengthens the hot spots downstream of the fin. That explains the small upward shift of this spot compared with that in the production of kinetic energy, while there the negative production over the fin surface pushed the hot spot towards the center. This also clarifies the observation made earlier on the existence of positive values of $\overline{v't}$ over the fin surface.

This comparison and the comparison between the second moments in the previous Figure show a clear dissimilarity between the heat transfer and momentum transfer processes. While both production terms have positive values just downstream of the fin, they have different signs over the fin surface. Negative values of the production of fluctuating kinetic energy indicate a suppression of momentum transfer in this area, while the temperature variance production has a positive value which reveals enhancement of heat transfer.

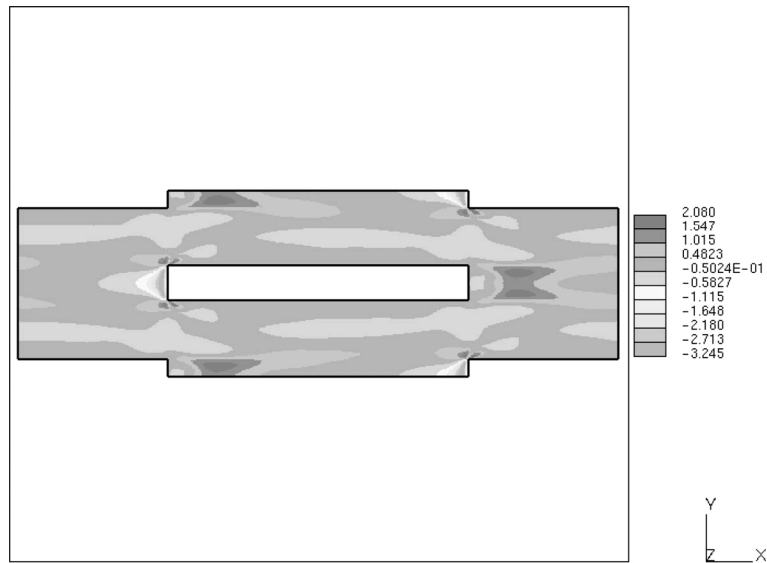

(a)

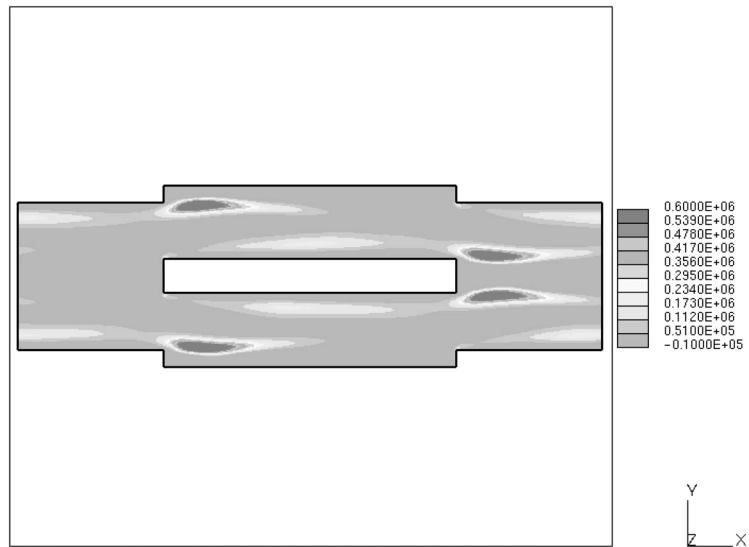

(b)

Figure 11.
Production of velocity
fluctuations due to
velocity gradients (a),
production of
temperature fluctuations
due to temperature and
velocity gradients (b)

Conclusions

A numerical analysis of the time-dependent flow over an offset strip fin geometry was carried out. The results were presented in three sections. In the first section, time-averaged mean values of the friction factor and the Colburn j factor were compared with the results of another numerical investigation

available in the literature. This comparison ensured that the present numerical investigation provided satisfactory accuracy.

In the second section, the unsteady flow structure has been considered. It was shown that the flow is not bounded in the channel type area just downstream of the fin or in the so-called “communicating” region. It was also shown that the velocity field has a pure oscillating motion. A dominating frequency of the oscillations is valid in the whole flow domain.

The contour plots of the second moment correlation of the fluctuating velocity components \overline{uv} and the second moment of the temperature-velocity fluctuations \overline{vt} were presented. The locations of maximum observed in the wake region for these moments occurred at the same spot but, unlike the \overline{uv} moment, positive values of \overline{vt} also exist in the region over the fin surface. Positive production of the fluctuating kinetic energy occurs only in the wake region, while in the boundary layer region over the fin surface negative production is found. In contrast, the production of the temperature variance possesses positive values even in the area over the fin surface. By comparing the second moments of the velocity and temperature-velocity fluctuations, and the production of fluctuating kinetic energy and temperature variance, the dissimilarity between the processes of heat transfer and momentum transport was identified. This dissimilarity is obviously beneficial, as the heat transfer enhancement is not coupled with an increased momentum transfer or pressure drop.

In summary the results of this study showed:

- That the mechanism of heat transfer enhancement revealed by fluctuating temperature and velocity fields for oscillating laminar flow situations can be studied by numerical solution methods of the governing equations.
- Evidence of the dissimilarity between heat transfer and momentum transfer, which has not been observed or studied for offset strip fin geometries before.
- The clear difference between the variances of velocity fluctuations in laminar self-oscillating flow and turbulent flow.

References

- DeJong, N.C., Zhang, L.W., Jacobi, A.M., Balachandar, S. and Tafti, D.K. (1998), “A complementary experimental and numerical study of flow and heat transfer in offset strip-fin heat exchangers”, *ASME J. Heat Transfer*, Vol. 120, pp. 690-8.
- Fitz-Hugh, J.S. (1973), “Flow induced vibration in heat exchangers”, *Oxford University Report RS57*, AERE-P7238.
- Jacobi, A.M. and Shah, R.K. (1996), “Air-side flow and heat transfer in compact heat exchangers: a discussion of physics”, *Process, Enhanced and Multiphase Heat Transfer – A Festschrift for A.E. Bergles*, Begell House, NY, pp. 379-90.
- Joshi, H.M. and Webb, R.L. (1987), “Heat transfer and friction in the offset strip fin heat exchanger”, *Int. J. Heat Mass Transfer*, Vol. 30, pp. 69-84.
- Kays, W.M. (1972), “Compact heat exchangers”, *AGARD Lecture Ser. No. 57 on Heat Exchangers*, AGARD-LS-57-72, NATO, Paris.

- Majumdar, D. and Amon, C.H. (1992), "Heat and momentum transport in self-sustained oscillatory viscous flows", *ASMEJ. Heat Transfer*, Vol. 114, pp. 866-73.
- Manglik, R.M. and Bergles, A.E. (1995), "Heat transfer and pressure drop correlations for the rectangular offset strip fin compact heat exchangers", *Exp. Thermal and Fluid Sci.*, Vol. 10, pp. 171-80.
- Mercier, P. and Tochon, P. (1997), "Analysis of turbulent flow and heat in compact heat exchanger by pseudo-direct numerical simulation", *Compact Heat Exchangers for the Process Industries*, Begell House, NY, pp. 223-30.
- Patankar, S.V. and Prakash, C. (1981), "An analysis of the effect of plate thickness on laminar flow and heat transfer in interrupted-plate passages", *Int. J. Heat Mass Transfer*, Vol. 24 pp. 1801-10.
- Sahnoun, A. and Webb, R.L. (1992), "Prediction of heat transfer and friction for the louver fin geometry", *ASMEJ. Heat Transfer*, Vol. 114, pp. 893-900.
- Saidi, A., Sundén, B. and Eriksson, D. (2000), "Intercoolers in gas turbine systems and combi-processes for production of electricity", *ASME paper 2000-GT-234*.
- Shah, R.K., Heikal, M.R. and Thonon, B. (1998), "Advances in numerical analysis of heat transfer and flow friction characteristics of compact heat exchangers' surface", *CHT'97: Advances in Computational Heat Transfer*, Begell House, NY, pp. 68-87.
- Sparrow, E.M., Baliga, B.R. and Patankar, S.V. (1977), "Heat transfer and flow analysis of interrupted-wall channels with application to heat exchangers", *ASME J. Heat Transfer*, Vol. 99, pp. 4-11.
- Suzuki, K., Hirai, E., Miyaki T. and Sato, T. (1985), "Numerical and experimental studies on a two-dimensional model of an offset-strip-fin type compact heat exchanger used at low Reynolds number", *Int. J. Heat Mass Transfer*, Vol. 28, pp. 823-36.
- Suzuki, K., Hirai, E., Sato, T. and Kieda, S. (1982), "Numerical study of heat transfer system with staggered array of vertical flat plates used at low Reynolds number", *Proc. 7th Int. Heat Transfer Conf.*, Vol. 3, pp. 483-8.
- Suzuki, K., Xi, G., Inaoka, K. and Hagiwara, Y.H. (1994), "Mechanism of heat transfer enhancement due to self-sustained oscillation from an in-line fin array", *Int. J. Heat Mass Transfer*, Vol. 37, pp. 83-96.
- Veersteg, H.K. and Malalasekera, W. (1995), *An Introduction to Computational Fluid Dynamics: The Finite Volume Method*, Longman Scientific & Technical Publishers.
- Wieting, R. (1975), "Empirical correlations for heat transfer and flow friction characteristics of rectangular offset-fin plate-fin heat exchangers", *ASME J. Heat Transfer*, Vol. 97, pp. 488-90.
- Xi, G., Hagiwara, Y. and Suzuki, K. (1992), "Effect of fin thickness on flow and heat transfer characteristics of fin array – an offset-fin array in the low Reynolds number range", *Heat Transfer-Japanese Res.*, Vol. 22, pp. 1-19.
- Xi, G., Hagiwara, Y. and Suzuki, K. (1995), "Flow instability and augmented heat transfer of fin arrays", *J. Enhanced Heat Transfer*, Vol. 2, pp. 23-32.
- Zhang, L.W., Tafti, D.K., Najjar, F.M. and Balachandar, S. (1997), "Computations of flow and heat transfer in parallel-plate fin heat exchangers on the CM-5: effects of flow unsteadiness and three-dimensionality", *Int. J. Heat Mass Transfer*, Vol. 40, pp. 1325-41.