



LUND UNIVERSITY

Animal colour vision - behavioural tests and physiological concepts

Kelber, Almut; Vorobyev, Misha; Osorio, Daniel

Published in:
Biological Reviews

DOI:
[10.1017/S1464793102005985](https://doi.org/10.1017/S1464793102005985)

2003

[Link to publication](#)

Citation for published version (APA):

Kelber, A., Vorobyev, M., & Osorio, D. (2003). Animal colour vision - behavioural tests and physiological concepts. *Biological Reviews*, 78(1), 81-118. <https://doi.org/10.1017/S1464793102005985>

Total number of authors:
3

General rights

Unless other specific re-use rights are stated the following general rights apply:

Copyright and moral rights for the publications made accessible in the public portal are retained by the authors and/or other copyright owners and it is a condition of accessing publications that users recognise and abide by the legal requirements associated with these rights.

- Users may download and print one copy of any publication from the public portal for the purpose of private study or research.
- You may not further distribute the material or use it for any profit-making activity or commercial gain
- You may freely distribute the URL identifying the publication in the public portal

Read more about Creative commons licenses: <https://creativecommons.org/licenses/>

Take down policy

If you believe that this document breaches copyright please contact us providing details, and we will remove access to the work immediately and investigate your claim.

LUND UNIVERSITY

PO Box 117
221 00 Lund
+46 46-222 00 00

Animal colour vision – behavioural tests and physiological concepts

ALMUT KELBER^{1*}, MISHA VOROBYEV^{2†} and DANIEL OSORIO³

¹ Department of Cell and Organism Biology, Vision Group, Lund University, Helgonavägen 3, S-22362 Lund, Sweden

² Department of Biological Sciences, University of Maryland Baltimore County, 1000 Hilltop Circle, Baltimore, MD 21250, USA

³ School of Biological Sciences, University of Sussex, Falmer, Brighton BN1 9QG, UK

(Received 3 September 2001; revised 15 April 2002)

ABSTRACT

Over a century ago workers such as J. Lubbock and K. von Frisch developed behavioural criteria for establishing that non-human animals see colour. Many animals in most phyla have since then been shown to have colour vision. Colour is used for specific behaviours, such as phototaxis and object recognition, while other behaviours such as motion detection are colour blind. Having established the existence of colour vision, research focussed on the question of how many spectral types of photoreceptors are involved. Recently, data on photoreceptor spectral sensitivities have been combined with behavioural experiments and physiological models to study systematically the next logical question: ‘what neural interactions underlie colour vision?’ This review gives an overview of the methods used to study animal colour vision, and discusses how quantitative modelling can suggest how photoreceptor signals are combined and compared to allow for the discrimination of biologically relevant stimuli.

Key words: colour, vision, model, behaviour, photoreceptor, threshold.

CONTENTS

I. Introduction	82
II. Photoreceptor signals	83
(1) Diversity of receptors	83
(2) Spectral tuning of receptors	86
(a) Measurement of receptor sensitivities	86
(b) Visual pigments	86
(c) Filters	87
(3) Modelling receptor signals	87
III. Colour vision concepts	88
(1) What is colour vision?	88
(2) Colour spaces, and the number of receptor types used for colour vision	89
(3) Achromatic and chromatic signals	89
IV. Uses of chromatic signals	91
V. Tests of colour vision	100
(1) Evidence for colour vision	100
(a) Grey card experiments	100
(b) Monochromatic stimuli	101
(c) Broadband stimuli at different intensities	102

* Author for correspondence: e-mail: almut.kelber@cob.lu.se

† Present address: Vision Touch and Hearing Research Centre, University of Queensland, Brisbane, Queensland, 4072, Australia.

(2) Tests of visual mechanisms	102
(a) Colour matching.....	102
(b) Discrimination of specially adjusted stimuli.....	103
(c) Receptor-based models of colour choices.....	103
VI. Modelling thresholds for colour discrimination.....	103
(1) Measuring thresholds	104
(2) Interpretations of the shapes of threshold sensitivity curves.....	104
(3) Metric spaces and quantitative analysis of threshold data.....	105
(a) Inferring neural mechanisms from threshold data	106
(b) Receptor noise and colour thresholds	108
(4) Threshold models as a tool to study the biological relevance of colour vision.....	109
VII. Conclusions.....	109
VIII. Acknowledgements	109
IX. Appendix A: Colour spaces	109
X. Appendix B: Receptor-noise-limited colour opponent model.....	111
XI. References.....	112

I. INTRODUCTION

Human colour science and psychophysics became established during the nineteenth century, and people began to ask whether animals see colour. Lubbock (1888) in his book *On the senses, instincts and intelligence of animals* demonstrated to his satisfaction that *Daphnia* sp. see colour, using the fact that they are both positively phototactic, and prefer yellow to white light which is more intense across the entire spectrum (see Section V.1c). Lubbock (1888) also made a good case that honeybees (*Apis mellifera*) can associate colour with food, but did not rule out their using brightness. It was left to von Frisch (1914) to confirm honeybee colour vision. At the same time the problem of equating human colour sensations with animal behaviour was well recognized. One critic (Anonymous, 1889) of Lubbock's book doubted that one can conclude that animals taste, see or hear simply because their movement is directed by sense organs analogous to our own. To this day doubts persist as to whether animals enjoy the sensation of, and hence can truly be said to see, colour (Cogan, 1995; Stoerig, 1998). Nonetheless, given the behavioural criteria of Lubbock and von Frisch (see Section III.1) it is evident that many animals use colour for tasks such as phototaxis where spectral composition identifies a light source, and for detecting and discriminating objects (Menzel, 1979; Jacobs, 1981; Mollon, 1989).

This review deals with three main questions, much as suggested by Menzel (1979): (1) Is colour vision used for a particular task? (2) How many spectral types of photoreceptor are involved? (3) What can be said about the post-receptoral neural

mechanisms of colour discrimination, such as chromatic opponency?

Concepts in colour vision are mostly derived from human perception and psychophysics. Human trichromacy was proposed first in the eighteenth century (Mollon, 1997), and models relating our colour discrimination to underlying receptor responses and neural mechanisms are over a century old (Maxwell, 1860; Hering, 1878; Helmholtz, 1896). When human cone spectral sensitivities were first directly measured (Bowmaker & Dartnall, 1980), they closely matched psychophysical predictions (Smith & Pokorny, 1975). As animals are more difficult to test than humans, most work has aimed simply to establish the existence of colour vision, rather than to determine receptor inputs and neural mechanisms.

When Jacobs (1981) wrote his book *Comparative Color Vision* most studies that went beyond demonstrating the existence of colour vision were from mammals, although there was also important work on honeybees (Daumer, 1956; von Helversen, 1972). Work on non-mammalian species is now becoming easier thanks to increasing numbers of measurements of photoreceptor spectral sensitivities (Table 1). The history of human colour vision can be reversed; once spectral inputs to the receptors are known (Fig. 1, stage 1) it is possible to study neural processing of signals arising from a single stimulus (Fig. 1, stage 2), and the mechanisms comparing signals from different stimuli (Fig. 1, stage 3).

We review two types of tests of colour discrimination. Firstly, tests of the ability to make a discrimination (Section V), and secondly measurements of discrimination thresholds (Section VI).

Before looking at experimental data we outline the diversity of visual photoreceptors that underlie colour vision (Section II), introduce some ideas relevant to understanding colour and how it is studied (Section III), and discuss the roles of achromatic and chromatic signals (Section IV).

II. PHOTORECEPTOR SIGNALS

(1) Diversity of receptors

Knowing photoreceptor spectral sensitivities simplifies the study of colour vision, and phylogenetic comparisons give insight into its evolutionary origins and function. For example, haplorrhine primates (i.e. monkeys and apes) often have three spectral types of cone, compared to two in most other mammals. Perhaps then trichromacy is an adaptation to the primates' particular diurnal lifestyle and frugivorous diet (Mollon, 1989). On the other hand, the fact that many bees and wasps have a similar set of three photoreceptors to the honeybee implies that honeybee trichromacy is not a specific adaptation to its being a generalist pollinator, being evolutionarily older than the life-style (Peitsch *et al.*, 1992). Swallowtail butterflies (*Papilio* sp.) might have evolved a fourth receptor type (sensitive to very long wavelengths) as an adaptation to oviposition on green leaves rather than to flower detection (Kelber, 1999).

Data on visual pigment and photoreceptor spectral sensitivities are increasing, especially for vertebrates. Microspectrophotometry (MSP) can be used where intracellular recording is difficult. Molecular genetics shows how opsins (pigment proteins) have evolved, and how specific aminoacid residues determine spectral tuning (Bowmaker, 1998; Bowmaker & Hunt, 1999; Nathans, 1999). Table 1 indicates the range in numbers and spectral tuning of photoreceptors in a selection of molluscs, arthropods and vertebrates.

Photoreceptor nomenclature is complicated, and potentially confusing. Receptors have been named either according to the part of the spectrum to which they are absolutely or relatively most sensitive: 'red', 'green', 'blue', 'UV' etc., or by their sensitivity relative to other receptors in the eye for example 'long' (L), 'short' (S) and 'medium' (M) wavelength sensitive. This nomenclature is satisfactory for referring to a given species or closely related group of species, but is less satisfactory and potentially confusing for more general comparisons. Moreover, given that four main gene families of

vertebrate cone opsin have been recognized (Hisatomi *et al.*, 1994; Bowmaker & Hunt, 1999), it seems desirable to use the terms VS ('very short'), S, M and L to refer to the opsin gene family, and to specify the spectral sensitivity maximum of the photopigment (see also Bowmaker & Hunt, 1999). For invertebrate photopigments we simply specify the spectral sensitivity maxima of each species' visual pigments or photoreceptors (Table 1).

Of invertebrates, *Octopus vulgaris* like most other cephalopod molluscs has a single spectral type of receptor. Some spiders and crustaceans have two types. *Daphnia magna* and perhaps jumping spiders (Salticidae) have four, while stomatopod crustaceans have up to 16. Among insects, cockroaches (Blattodea) and some ants have two spectral receptor types, while most bees and wasps have three (Peitsch *et al.*, 1992). Dragonflies (Odonata) and sawflies (Tenthredinidae) have four spectral types of receptor, and some flies (Diptera) and butterflies have five or more (Table 1; reviewed by Briscoe & Chittka, 2001).

In vertebrates, the two main types of visual photoreceptor cell, rods and cones, are distinguished by a number of morphological and physiological features (Cohen, 1972). Normally, rods are active at low (scotopic) light intensities, and cones at high (photopic) intensities. Colour vision uses mainly cone signals, but goldfish (*Carassius auratus*) may use rods and red (L) cones in dim light (down to 1 or 2 log units above absolute threshold: Powers & Easter, 1978*b*), and rods contribute to colour vision in amphibians (Muntz, 1963) and humans (Wysszecki & Stiles, 1982).

Of the more primitive vertebrates, lampreys have one rod and two anatomically distinct types of cone (Collin, Potter & Braekevelt, 1999), but only two photopigments have been described (Table 1). Many teleost fishes, reptiles and birds have one rod and four cone opsins. These form five families defined by amino acid sequences and characterized by the locations of their spectral sensitivity maxima (Table 1; Hisatomi *et al.*, 1994; Bowmaker, 1998; Bowmaker & Hunt, 1999): rod, very short (VS, or violet/ultraviolet), short (S, or blue), medium (M, or green) and long (L, or red). *Rana* spp. frogs also have up to five receptor types, however two of them are rods (a 'red' rod and a 'green' rod, Table 1). Vertebrate lineages often lose visual photopigments, for example many teleost fish along with most mammals have only two cone pigments, while snakes, crocodiles and geckos have three.

Mammals lost two cone opsin families, probably during an early 'nocturnal' phase of evolution,

Table 1. *Examples of receptors in different animal classes, other reviews listed give additional information about specific taxa. We give the species names, the method used to determine sensitivity, and sensitivity maxima. Vertebrate receptors are classified according to the probable gene family of their opsin (see Section II): VS (very short wavelength or UV receptor), S (short wavelength), M (medium wavelength), L (long wavelength). For invertebrates, sensitivity maxima are mostly of receptors in vivo, whereas for vertebrates (other than ERG) they are generally sensitivities of isolated receptors, and do not take account of intraocular filtering. Methods: E, electrophysiological recording, mostly intracellular for invertebrates and suction electrode recordings for vertebrates; ERG, electroretinogram; MSP, microspectrophotometry of photoreceptors or (MSP-G) artificially expressed*

Animal group	Method	Sensitivity maxima (nm)				Reference	
Molluscs							
Bivalva (<i>Tridacna</i> sp.)	E	360	490	540		Wilkens (1984)	
Octopus (<i>Octopus vulgaris</i>)	E	470				Messenger (1981)	
Firefly squid (<i>Watasenia scintillans</i>)	MSP	470	485	500		Matsui <i>et al.</i> (1988)	
Spiders							
Jumping spider (<i>Plexippus validus</i>)	E	360	520			Blest <i>et al.</i> (1981)	
Jumping spider (<i>Menemerus confusus</i>)	E	360	490	520	580	Yamashita & Tateda (1976)	
Ctenid spider (<i>Cupiennius salei</i>)	E	340	480	520		Walla <i>et al.</i> (1996)	
Crustaceans							
Water flea (<i>Daphnia magna</i>)	E	348	434	525	608	Review: Marshall <i>et al.</i> (1999)	
Mantis shrimp (<i>Neogonodactylus</i> sp., <i>Odontodactylus</i> sp.)	E/MSP	12 +	(maxima from 315 to 654 nm)			Smith & Macagno (1990)	
Isopod (<i>Ligia exotica</i>)	E	340	470	520		Cronin & Marshall (1989); Marshall & Oberwinkler (1999)	
Crayfish (<i>Procambarus clarkii</i>)		460	560/600			Hariyama <i>et al.</i> (1993)	
Insects							
Cockroach (<i>Periplaneta americana</i>)	E	365	510			Nosaki (1969)	
Dragonfly (<i>Sympetrum rubicundum</i>)	E	330	430	490	520	620	Reviews: Menzel & Backhaus (1991); Briscoe & Chittka (2001)
House fly (<i>Musca domestica</i>)	E	335	355	460	490	530	Mote & Goldsmith (1970)
Honeybee (<i>Apis mellifera</i>)	E	344	436	556			Meinertzhagen <i>et al.</i> (1983)
Butterfly (<i>Papilio xuthus</i>)	E	360	400	440	520	600	Hardie (1986)
Vertebrates							
		Rod	VS	S	M	L	Reviews: Bowmaker (1995) (fish); Bowmaker (1998)
Lamprey (<i>Lampetra lampetra</i>)	MSP	515	555				Govardovskii & Lychakov (1984)
Sturgeon (<i>Acipenser baeri</i>)	MSP	549		465	549	613	Govardovskii <i>et al.</i> (1991)
Goldfish (<i>Carrassius auratus</i>)	MSP/E	522	356	447	537†	623†	Bowmaker <i>et al.</i> (1991); Palacios <i>et al.</i> (1998)
Cichlid (<i>Aequidens pulcher</i>)	MSP	500		453	530†	570†	Kröger <i>et al.</i> (1999)
Amphibians*							
Frog (<i>Rana</i> spp. * including <i>R. catesbeiana</i>)	MSP/ERG	430	?	431	502	562	Liebman & Entine (1968); Govardovskii & Zueva (1974); Koskelainen <i>et al.</i> (1994)
Salamander (<i>Ambystoma tigrinum</i>)	E	506	400	444		610	Perry & McNaughton (1991)

Reptiles						
Crocodile (<i>Alligator mississippiensis</i>)	MSP	501	444	535	566†	Sillman <i>et al.</i> (1991)
Turtle (<i>Pseudemys scripta</i>)	MSP		360	450	518	620 Baylor & Hodgkin (1973); Loew & Govardovskii (2001)
Lizard (<i>Anolis carolinensis</i>)	MSP-G		358	437	495	560 Kawamura & Yokoyama (1998)
Gecko (<i>Gekko gekko</i>)	MSP		364	467	521	Loew (1994)
Birds†						
Chicken (<i>Gallus gallus</i>)	MSP	506	418	455	507	569 Bowmaker <i>et al.</i> (1997)
Pekin robin (<i>Leiothrix lutea</i>)	MSP	500	355	454	499	568 Maier & Bowmaker (1993)
Mammals						
Dolphin (<i>Tursiops truncatus</i>)	MSP-G	488				524 Fasick <i>et al.</i> (1998)
Squirrel (<i>Spermophilus</i> sp.)	ERG	500	436			518 Jacobs (1993)
Human	MSP/E	498	437		533‡	564‡ Bowmaker & Dartnall (1980); Schnapf <i>et al.</i> (1987)

* Some vertebrates including various fish and amphibia express both retinal and dehydroxyretinal as the chromophore in a single class of photo-receptor or even a single cell (e.g. Firsov *et al.*, 1994; Partridge & Cummins, 1999). Dehydroxyretinal red-shifts the spectral sensitivity by over 50 nm for long-wavelength-sensitive opsins. Where receptors may use both types of chromophore we give the value for the retinal-bearing variant.

† Bird double cones contain the long-wavelength-sensitive visual pigment and are not thought to contribute to colour vision, fishes can use double cones for colour vision and the pigments of the principle and accessory cones are given.

‡ Primate M and L receptor pigments are both derived from the mammal L pigment. They are named M and L for convenience.

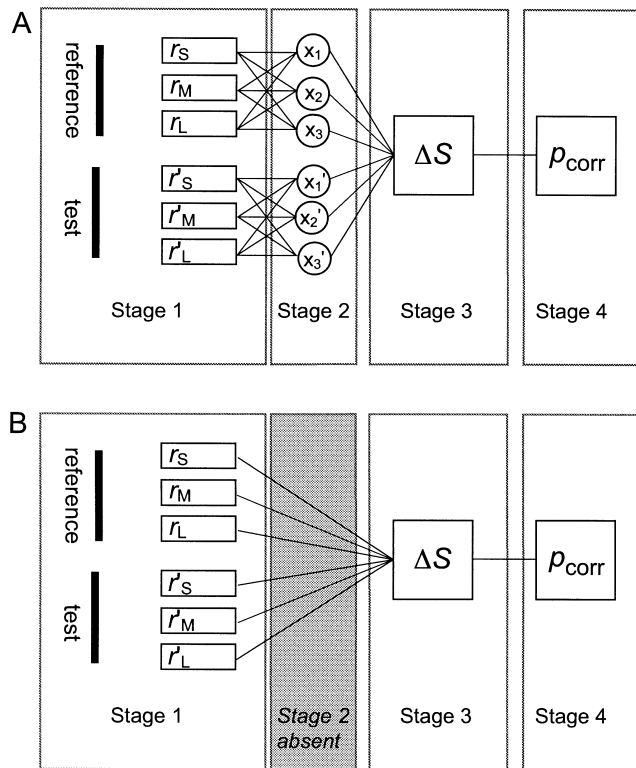

Fig. 1. (A) Diagram of a four-stage model of colour discrimination by a trichromatic eye (modified from Brandt & Vorobyev, 1997). Stage 1: responses of receptors (r , r') sensitive to short (S), medium (M) and long (L) wavelengths of light, to reference and test stimuli. Stage 2: achromatic and/or chromatic interactions between signals. Three mechanisms are needed to represent all the information (x_1 , x_2 , x_3 , for the reference and x'_1 , x'_2 , x'_3 , for the test stimulus) encoded by three receptor types. Stage 3: ΔS represents the distance of the two stimuli in colour space, this distance depends on the metrics (see Figs 3, 4). At stage 4, either the test or the reference stimulus is selected with a probability P_{corr} . (B) Model that does not include stage 2 mechanisms; many models are of this type, see Figs 3B, C, 4C, and 5A, *ii* and *iii*.

leaving them with L and VS opsins (Jacobs, 1993; Bowmaker, 1998; Bowmaker & Hunt, 1999). Mammalian VS photopigment and cones are commonly called 'S' (i.e. short-wavelength sensitive). This S cone opsin is probably absent from dolphins and seals (Peichl, Behrmann & Kröger, 2001) and from nocturnal species including racoons (*Procyon* spp.) and owl monkey (*Aotus* sp.; Ahnelt & Kolb, 2000); these species are cone monochromats. Conversely, many primates, including all known Old-World monkeys (Catarrhini), have recovered three types of cone pigment by evolving separate 'L' (red) and 'M' (green) opsins from the ancestral L opsin gene (Bowmaker, 1998; Nathans, 1999).

(2) Spectral tuning of receptors

(a) Measurement of receptor sensitivities

A photoreceptor's spectral sensitivity is given by the relative likelihood of absorption of a photon incident on the cornea, as a function of its wavelength. Once a photon is absorbed, the electrical responses of visual photoreceptors are (so far as is known) independent of its wavelength. This 'principle of univariance' (Rushton, 1965) means that the intensities of two visible spectra can always be adjusted to give equal responses, so that individual photoreceptors are 'colour blind'.

Spectral sensitivities can be established in various ways (Table 1). In invertebrates, the usual and direct method is by intracellular recording from photoreceptors *in vivo* the response to (typically) monochromatic stimuli of known intensity (Autrum & von Zwehl, 1964; Peitsch *et al.*, 1992). In vertebrates, suction electrode recording of isolated receptors is often more practical (Schnapf, Kraft & Baylor, 1987). Electroretinograms (ERG) combined with selective adaptation are widely used with vertebrates (Jacobs, 1993), but may be difficult to interpret when there are three or more spectral types of receptor. Alternatively, absorption spectra of photopigments, and other visual media can be measured by spectrophotometry, and receptor spectral sensitivities can be estimated from these spectra. Spectrophotometry can be performed either in photoreceptors (Liebman & Entine, 1968; Cronin & Marshall, 1989; Bowmaker *et al.*, 1997), or artificial expression systems (Asenjo, Rim & Oprian, 1994; Fasick *et al.*, 1998; Nathans, 1999). Finally, spectral sensitivity of some vertebrate pigments can now be predicted from the amino acid composition of the opsin (Asenjo *et al.*, 1994; Nathans, 1999; Bowmaker & Hunt, 1999).

(b) Visual pigments

Visual photopigments are G-protein-coupled receptors, which comprise an opsin protein and a carotenoid chromophore. When a chromophore absorbs a photon it isomerizes, and this causes the opsin to change conformation to activate phototransduction (Aidley, 1998). The visual pigment's spectral sensitivity depends both upon the chromophore and the opsin, but for a given chromophore the shape of the curve is a predictable function of the peak wavelength (Dartnall, 1953; Govardovskii *et al.*, 2000). The commonest chromophore is retinal, the

aldehyde derivative of vitamin A1, but fishes, amphibians and reptiles sometimes have 3,4-dehydroxyretinal, the derivative of vitamin A2 (porphyropsin; Wald, 1939; Provencio, Loew & Foster, 1992), and many insects use 3-hydroxyretinal, a derivative of xanthophylls (Vogt & Kirschfeld, 1984). Substitution of A2 for A1 red-shifts sensitivity, and this underlies some variation in fish and amphibians (Liebman & Entine, 1968). The squid *Watasenia scintillans* is remarkable for having three visual pigments based on one opsin and three types of chromophore (Matsui *et al.*, 1988). Normally though, the main source of variability in spectral sensitivities is the opsin. For A1-based visual pigments, sensitivity maxima range from approximately 310 nm to 570 nm, and for A2-based pigments up to 635 nm (Provencio *et al.*, 1992).

Usually a single photoreceptor cell contains one type of visual pigment, but there are exceptions, the best known being the presence of mixtures of A1 and A2 visual pigments in fish and amphibians (Firsov, Govardovskii & Donner, 1994). Mouse (*Mus musculus*), and possibly wallaby (*Macropus eugenii*) express two different opsins in the same cone photoreceptor (Röhlich, van Veen & Szel, 1994; Hemmi & Grünert, 1999; Neitz & Neitz, 2001). The swallowtail butterfly (*Papilio xuthus*) has a complex set of photoreceptors, some of which co-express two opsin genes (Kitamoto *et al.*, 1998). Other receptors in this butterfly express a single opsin, but adopt different sensitivities depending on the presence of 3-hydroxyretinol, which works as a UV-absorbing screening pigment (Arikawa *et al.*, 1999). On the other hand, flies use 3-hydroxyretinol as an antennal pigment, which broadens spectral sensitivity by adding a UV peak (Hardie, 1986; Vogt, 1989).

(c) Filters

Receptor sensitivities depend primarily on their visual pigments, but ocular filters often have a marked effect (Walls, 1942; Douglas & Marshall, 1999). Yellow lenses of diurnal mammals and some fishes absorb UV and violet light. The coloured oil droplets in cone inner segments of many diurnal reptiles and birds are of particular interest (Walls, 1942; Partridge, 1989; Goldsmith, 1991; Hart, 2001). These droplets vary in colour, and early workers attributed a variety of functions to them, most notably as a basis for colour vision in animals assumed to have only a single visual pigment (e.g. Walls, 1942; King-Smith, 1969). For vertebrates this latter theory was doubted by Walls (1942), and now

seems unlikely because, at least in turtles and birds four types of oil droplets are each associated with a specific type of single cone photopigment (Bowmaker *et al.*, 1997; Loew & Govardovskii, 2001). Typically, oil droplets cut off light of short wavelengths from a value around the sensitivity maximum of the opsin (Hart, 2001), and this appreciably sharpens spectral tuning. Model calculations have recently provided clear evidence that this sharpening indeed benefits colour vision (Vorobyev *et al.*, 1998).

In the grasshopper *Phaeoba* sp., corneal filters over a single spectral type of photopigment may indeed provide a basis for colour vision (Kong, Fung & Wasserman, 1980). Corneal filters are common in tachinid flies, but it is uncertain how they affect spectral sensitivities. More generally, invertebrates have a wide variety of intraocular filters using photostable pigments (Douglas & Marshall, 1999). Also, some compound eyes such as those of butterflies and stomatopods have ‘tiered retinae’ where light passes first through ‘distal’ receptor cells in an ommatidium, and so is filtered, before it reaches the proximal cells (Cronin & Marshall, 1989; Douglas & Marshall, 1999). In compound eyes, there is also ‘lateral’ filtering, where several photoreceptor spectral types combine to form a single light-guiding rhabdom and hence compete for photons (see Section II.3).

(3) Modelling receptor signals

The physical stimulus for vision is the number of quanta absorbed by a receptor per unit time (e.g. receptor integration time). Due to the availability of cheaper spectrophotometers large numbers of biologically relevant stimuli have recently been measured and used for modelling. Where the spectral distribution of a light stimulus, $I(\lambda)$ is known, the quantum catch, Q_i , of a receptor type i , with spectral sensitivity, $R_i(\lambda)$, is given by:

$$Q_i = \int I(\lambda) R_i(\lambda) d\lambda, \quad (1)$$

where integration is over the visible spectrum. Stimulus intensity can be given either in quantum or in energy units, but the units of light stimulus and spectral sensitivity must correspond. Quantum units are commonly used in animal studies, and are appropriate since photoreceptors act as quantum counters. In human psychophysics, energy units are more often used. If $E(\lambda)$ is the spectrum of a light stimulus in energy units, then the spectrum in quantal units, $I(\lambda)$, is given by:

$$I(\lambda) = \lambda/hc E(\lambda), \quad (2)$$

where h is Planck's constant and c the velocity of light. Similarly, the relationship of spectral sensitivity in quantum units, $R_i(\lambda)$, to that in energy units, $R_i^E(\lambda)$ is given by:

$$R_i(\lambda) = hc/\lambda R_i^E(\lambda). \quad (3)$$

Usually relative rather than absolute sensitivity is important, in which case the constant hc is omitted, and spectral sensitivity is transformed from energy to quantum units by dividing by wavelength. To derive spectral sensitivity from spectrophotometric measurements, let $F_i(\lambda)$ be the attenuation of incoming light by optical filters in the light path to the visual pigments, and $k_i(\lambda)$ the extinction coefficient (absorption in a thin layer) of a pigment i , and x the length of a photoreceptor. Then the receptor response, $R_i(\lambda)$, is given by:

$$R_i(\lambda) = CF_i(\lambda)\{1 - \exp[-k_i(\lambda)x]\}. \quad (4)$$

C is a proportionality factor that describes the receptor's absolute sensitivity. The second term in eqn (4) describes 'self-screening' by the visual pigment, which being spectrally selective, removes the wavelengths to which it most sensitive so that the long receptor has a broadened spectral sensitivity. Warrant and Nilsson (1998) give a simplified expression for this term. When x is small $1 - \exp(-k_i(\lambda)x) \cong k_i(\lambda)x$. For arthropod eyes optical modelling is complicated, because light may be filtered as it travels along the rhabdom (photoreceptors). In fused rhabdoms, the visual pigments of different receptor types act as filters for each other thus narrowing the spectral sensitivity of each receptor type. If sensitivities of the pigments are known, spectral sensitivities can be calculated (Snyder, Menzel & Laughlin, 1973).

III. COLOUR VISION CONCEPTS

(1) What is colour vision?

Understanding colour starts from our own subjective experience. Colours have the qualities of hue, saturation and brightness. Brightness is the value on the dark to light scale. Saturation describes a colour's similarity to a neutral grey or white: a grey object with a small reddish tint has low saturation, whereas a red object with little white or grey tint is highly saturated. Hue refers to colour differences other than

those of brightness and saturation, and is the attribute denoted by terms such as red, yellow, green or purple (Wyszecki & Stiles, 1982; Byrne & Hilbert, 1997; Backhaus, Kliegl & Werner, 1998). Brightness is the achromatic aspect of colour, and hue and saturation are chromatic aspects. There is no evidence that animals perceive hue, saturation or brightness as separate qualities, or that they categorize colours as yellow, red etc. Indeed some workers insist that colour perception requires consciousness; what we call colour vision, on behavioural criteria, Stoerig (1998) recognizes as 'wavelength information processing'.

A comprehensive definition of colour from the standard handbook of colour science (Wyszecki & Stiles, 1982, p. 487) is 'that aspect of visual perception by which an observer may distinguish differences between two structure-free fields of view of the same size and shape, such as may be caused by differences in the spectral composition of the radiant energy ...'. The advantage of this definition is that it is not based on the human sensation of colour but on a physical measurement – 'the spectral composition of radiant energy' – therefore it can be applied to animals. Paradoxically, by this definition, the ability to discriminate colours does not entail colour vision.

Humans discriminate colours by means of chromatic (hue, saturation) as well as achromatic (brightness) signals. Colour-blind people (monochromats, including all humans in very dim light intensities) discriminate many colours by means of brightness. Colour vision, in humans, therefore means the ability to discriminate colours by their chromatic aspect, even though achromatic signals contribute to human colour perception, i.e. subjects with colour vision can discriminate colours of equal brightness. We do not know whether animals perceive brightness or hue, thus a general working definition for colour vision needs to be based on a physical criterion. Brightness relates to the sensitivity of the achromatic channel in a visual system. A light of 700 nm wavelength of high intensity might look as bright as a light of 550 nm at low intensity. Intensity is measured as the number of quanta incident on the eye per unit area, angle in space and unit time interval. For monochromats, it is always possible to adjust the intensities of two spectral stimuli to yield equal sensations. For humans with colour vision, colours with different saturation or hue cannot be made indiscriminable by adjusting stimulus intensity.

When describing animal colour vision we will refer to intensity-related cues as achromatic cues,

and to the signal they generate in the animal's visual system, as the achromatic signal. In humans, this signal leads to the perception of brightness. We conclude that an animal has colour vision if it can discriminate two lights of different spectral composition, regardless of their relative intensity (e.g. DeValois & DeValois, 1997; Menzel, 1979; Neumeyer, 1991; Goldsmith, 1991; Byrne & Hilbert, 1997). Section V describes experiments required to test colour vision.

(2) Colour spaces, and the number of receptor types used for colour vision

As we have just seen, animals with a single spectral type of photoreceptor are monochromats in that it is always possible to adjust the relative intensities of two spectra to give identical responses (Rushton, 1965). If more than one light, or primary, is needed to match colour the animal has colour vision. Colour vision is classified as dichromatic, trichromatic, tetrachromatic etc., according to the number of lights required to match any spectral light. This number cannot exceed the number of receptor types in the eye but may be fewer, and needs to be established behaviourally. Most vertebrates, for example, normally do not use rods for colour vision. Flies have two anatomically separate visual pathways; one of these is probably used for colour vision and receives input from four of their five receptor types (Troje, 1993).

Normal human observers are trichromats, because any spectrum can be matched by a unique combination of three primary spectra. Trichromacy was first proposed in the eighteenth century by Lomonosov, Palmer and Young (Mollon, 1997), and established experimentally by Maxwell (1860). The intensities of the three primaries that match a given light are called 'tristimulus values', and these give a quantitative description of its colour. Tristimulus values are linearly related to the quantum catches in the three types of cone (Fig. 2B; Wyszecki & Stiles, 1982). Hence, for humans colour can be specified either by the intensities of three known spectra required for a match, or by the quantum catches Q_i of the three receptor types. A colour can then be represented geometrically, as a point Q in a colour space, whose dimensionality is given by the number of primaries required for a colour match, or by the number of receptor types involved (Fig. 2, Appendix A). Colour matching establishes directly the dimensionality of colour vision, and thus the number of

receptors used independently for colour discrimination (see Section V.2). Colour matching includes the possibility that one of the primaries is added negatively – i.e. it is added to the colour that one tries to match instead of the other primaries. Otherwise it is not possible to match colours that lie outside the polygon in the colour space set by the primaries.

For humans, spectral sensitivities of the cardinal axes of commonly used colour spaces (e.g. RGB, XYZ; Wyszecki & Stiles, 1982) were chosen before the cone sensitivities were known. Likewise, Daumer (1956) proposed a trichromatic colour space for honeybees from colour-matching experiments. But Daumer's work is an exception, and in most animal studies the cardinal axes of colour spaces represent receptor responses (Appendix 1; Menzel & Backhaus, 1991; Neumeyer, 1991; Goldsmith, 1991; Brandt & Vorobyev, 1997; Vorobyev & Menzel, 1999; Osorio, Miklósi & Gonda, 1999a; Osorio, Vorobyev & Jones, 1999b).

In practice, the dimensionality of colour vision has been studied in few animals. Many mammals are dichromats save primates which are often trichromats (Jacobs 1981, 1993), as are bees (Daumer, 1956). Goldfish, turtle (*Pseudemys scripta elegans*), pigeon (*Columba livia*) and chicken (*Gallus gallus*) are probably tetrachromats (Arnold & Neumeyer, 1987; Neumeyer, 1992; Palacios *et al.*, 1990; Palacios & Varela, 1992; Osorio *et al.*, 1999b).

(3) Achromatic and chromatic signals

The existence of multiple spectral types of photoreceptor is not sufficient for colour vision. Subsequent neural stages (Fig. 1, stages 2 and 3) are necessary, and we are generally interested in the behavioural manifestations of these neural mechanisms (Fig. 1, stage 4). In the simplest arrangement, behaviour is directly driven by the response of one or more receptors to a stimulus (Fig. 1B). When only one receptor is involved, behaviour is colour blind, and the corresponding channel is called achromatic. When signals of several receptors are directly used to discriminate stimuli behaviour is no longer colour blind – even if no chromatic interaction occurs. Alternatively, receptor signals may interact (Fig. 1A; stage 2). Visual neurons may either sum photoreceptor signals, or compare them by some type of inhibitory interaction to give the ratio or difference of receptor signals. Chromatic mechanisms involve the comparison of receptor outputs, while achromatic mechanisms involve only additive

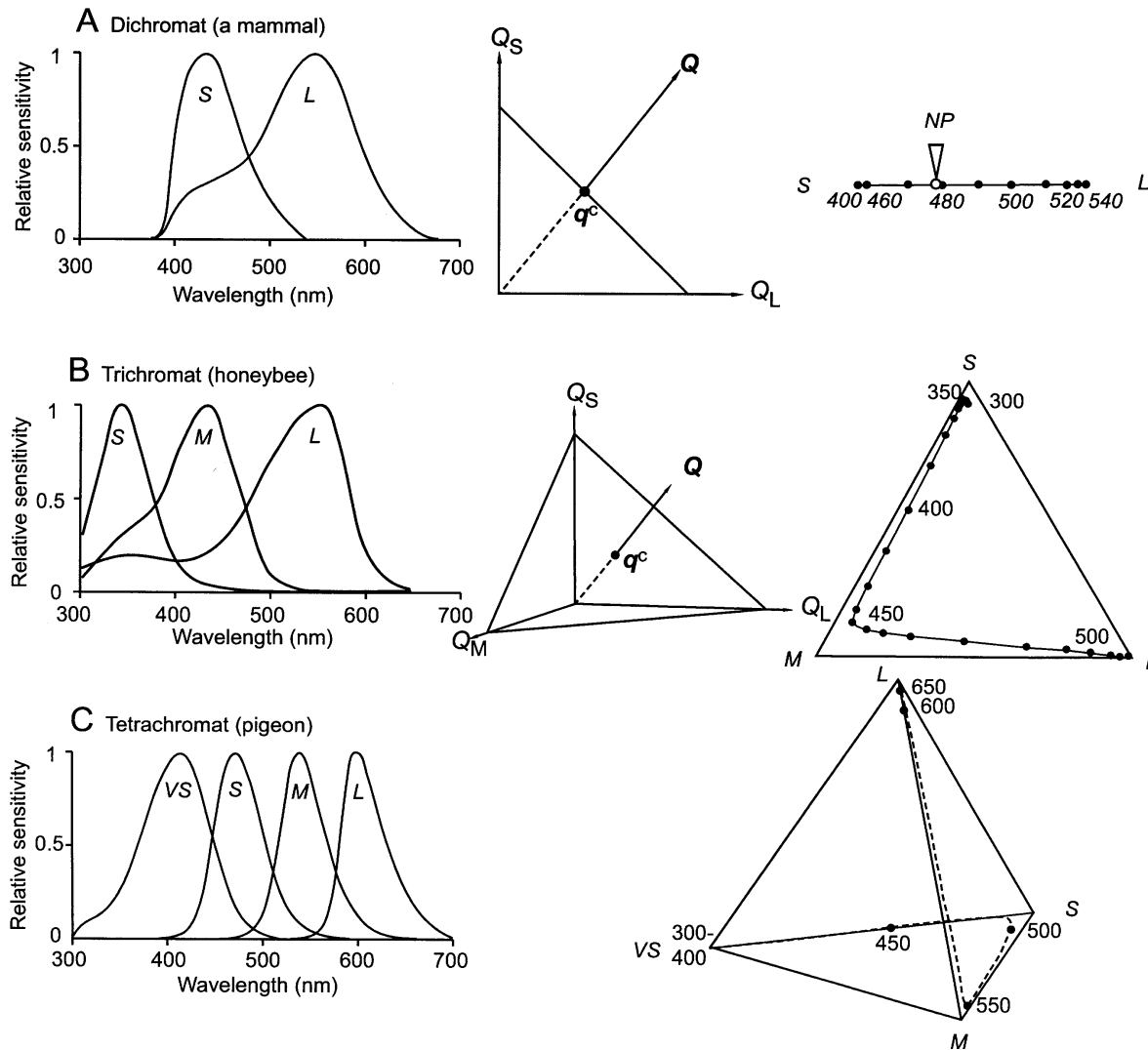

Fig. 2. Relative sensitivities of photoreceptors (left), receptor spaces (middle), and chromaticity diagrams with monochromatic loci (right) for representative di- (A), tri- (B) and tetrachromatic eyes (C). Colour is represented as a point Q in the receptor space, where each co-ordinate axis corresponds to the quantum catches of very short- (VS), short- (S), medium- (M) and long-wavelength-sensitive (L) receptors. Receptor spaces thus have n dimensions for visual systems with n receptors; the four-dimensional receptor space can not be visualized. Chromaticity diagrams (right) where $\sum Q_i = 1$, are projections of the receptor space to $n - 1$ dimensions. A line (dashed) connecting Q with the origin intersects the chromaticity diagram (a line, for dichromats; a plane, for trichromats, and a three-dimensional space, for tetrachromats) in a point q^c . The vertices of chromaticity diagrams (VS, S, M, L) represent colours that are represented on the axes of the colour spaces (middle). Colour loci of monochromatic lights are represented by the dashed line, and plotted points every 10 nm (A, B) or 50 nm (C). NP in A indicates the neutral point of a dichromat, i.e. the wavelength of light that has the same chromaticity coordinates as white light. See Appendix A for details of receptor spaces, and the corresponding chromaticity diagrams.

interactions. n degrees of freedom in post-receptoral neural signals are required to encode all the information represented by a retina with n spectral types of photoreceptor.

Historically, Helmholtz (1896) proposed that human colour vision did not require interactions between the three receptor mechanisms, and many

subsequent models of colour vision implement his hypothesis. Hering (1878), on the other hand, argued that interactions are essential, and that two opponent channels – yellow-blue and red-green – underlie human colour sensations. Helmholtz and Hering models can be reconciled by recognizing that colour vision is a multistage process (Fig. 1; see

Chapter 8 in Wyszecki & Stiles, 1982). Psychophysical evidence indicates that humans combine their three receptor signals to give one achromatic (or luminance) signal, and two chromatic signals (Jameson & Hurvich, 1955; Krauskopf, Williams & Heeley, 1982). The achromatic aspect of colour – brightness – is mediated by non-opponent mechanisms, whereas the chromatic aspects of colour – hue and saturation – are mediated by opponent mechanisms. Regardless of whether animals perceive saturation, hue and brightness, we can hypothesize that they have similar chromatic and achromatic mechanisms. Nonetheless, care is required to interpret behavioural experiments as evidence for post-receptor (stage 2) interactions, and we return to this subject in Section VI.

It should be possible to relate psychophysically defined mechanisms to neural responses, but even for primates this is not easy. Macaque (*Macaca macaca*) retinal ganglion cells, which transmit signals up the optic nerve, do fall into three main spectral types: those coding mainly luminance, yellow-blue opponent cells, and the cells of the parvocellular pathway, which probably represent the red-green signal (Dacey, 2000). Ganglion cell spectral sensitivities do not however match psychophysical predictions, for example they fail to predict the redness of short wavelength (violet) light. There are recordings for spectral opponent neurons in many other species, which we cannot review here. However, it is worth noting that Backhaus (1991) relates electrophysiological recordings from colour opponent neurons in honeybees to opponent mechanisms proposed from behavioural studies (see Section V.2c).

IV. USES OF CHROMATIC SIGNALS

Colour vision seems to be useful. Most eyes have multiple spectral types of photoreceptor (Table 1), and most animals have colour vision (Table 2), but it is not easy to specify the costs and benefits. Costs arise because colour vision compromises absolute sensitivity and (often) spatial resolution (van Hateren, 1993; Osorio, Ruderman & Cronin, 1998). Moreover, many processes such as directional motion detection are generally colour blind. Various theoretical studies have considered the consequences of varying the numbers and tuning of spectral photoreceptor types (Barlow, 1982; Maloney, 1986; van Hateren, 1993), but no theory accounts well for the diversity in numbers and spectral tuning

of photoreceptors across the animal kingdom (Table 1).

Despite the lack of a satisfactory quantitative model, intuitively it seems reasonable that chromatic signals are useful for object detection and identification. Under shadows and patchy illumination as in forests or shallow water, variations in light intensity cause large variations in receptor signals from a given surface. The ratio of signals from two receptor types is however comparatively robust with respect to illumination, and hence a better indicator of object properties (Rubin & Richards, 1982; Mollon, 1989; Maximov, 2000). According to this argument chromatic signals should ideally represent this ratio of receptor responses, making them insensitive to variations in intensity, but other signals such as the differences of receptor responses would also be useful. Even so, variable illumination will affect chromatic signals, making it necessary to ‘discount’ the illuminant by colour constancy (Hurlbert, 1998). Many animals have colour constancy but we do not deal here with this subject, which was reviewed recently by Neumeyer (1998).

Given the capacity of nervous systems to combine signals with different weightings, and to perform a large variety of operations, the coding of colour should reflect the fact that chromatic and achromatic signals are useful for different purposes. This means that when achromatic cues are used, as for motion detection, chromatic signals are disregarded, and when chromatic signals are used, as for the recognition of the colour of food sources, achromatic information may often be disregarded because it is unreliable. As we have said, one might expect a wide range of animals to have chromatic mechanisms whose responses are independent of intensity.

Honeybees are an example of a species with intensity-independent colour vision (see Section VI). In his pioneering work, von Frisch (1914) trained bees to feed from a sugar solution presented on a blue (or a yellow) card, and found that they could discriminate the training colour from 30 different shades of grey. Indeed, his bees were unable to learn to discriminate between greys of different intensity, which implied that they had learned only chromatic signals. On the other hand, motion vision in honeybees is colour-blind (Lehrer, 1993). Where animals use either chromatic or achromatic cues in different behaviours, as bees (von Frisch, 1914) and birds (Goldsmith, Collins & Perlman, 1981) do, it can be shown very convincingly that an animal discriminates colour stimuli regardless of their relative intensities.

Table 2. *Animal species (excluding primates) that have been shown to use colour vision in different behavioural experiments. As in the Introduction, we pose three questions, is colour vision used for a particular behaviour (q1)? How many spectral types of receptor are involved (q2)? How many chromatic mechanisms are found (q3)? Only experiments which give an answer (or at least an indication) to one of the questions are listed here. We note whether colour vision has been proved (yes to q1) or there is only a strong indication (ind.) for colour vision. For example, spectral sensitivity curves per se do not provide proof of colour vision. The number of receptors and post-receptor mechanisms (Fig. 1, stage 2) used for colour vision is given if it was determined by behavioural tests and/or model calculations (q2 and q3). Some experiments gave evidence that a specific receptor (VS, very short wavelength receptor; S short wavelength receptor; M medium wavelength receptor; L, long wavelength receptor) is involved, this is mentioned in the comment. Under method we give the type of experiment, the behaviour used to test the animal and whether spontaneous or trained behaviour was used. We refer to other review articles for some animal groups. For detailed descriptions of methods, see Sections V and VI*

Animal species	Method	Reference	q1	q2	q3	Comments
Mites						
Two-spotted spider mite (<i>Tetranychus urticae</i>)	Monochromatic stimuli, phototaxis	McEnroe & Dronka (1966)	Ind.			
Water mite (<i>Unionicola intermedia</i>)	Monochromatic stimuli, phototaxis	Dimmock & Davids (1985)	Yes			
Spiders						
Jumping spider (<i>Hasarius adansoni</i>)	Grey card experiment, heat avoidance reaction	Nakamura & Yamashita (2000)	Yes			First clear evidence for colour vision in spiders
Crustaceans						
Common shrimp (<i>Crangon vulgaris</i>)	Grey card experiment, camouflage	Koller (1927)	Ind.			
Hermit crabs (<i>Clibanarius misanthropus</i> , <i>Eupa-gurus anachoretus</i>)	Grey card experiment, spontaneous choices of shell homes	Koller (1928)	Yes			
Fiddler crab (<i>Uca pugilator</i>)	Monochromatic stimuli, phototaxis	Hyatt (1975)	Yes			
Water flea (<i>Daphnia magna</i>)	Broadband stimuli, phototaxis	Lubbock (1888), von Frisch & Kuppelwieser (1913)	Yes			
	Monochromatic stimuli, phototaxis	Koehler (1924), Storz & Paul (1998)	Yes			
Mantis shrimp (<i>Odontodactylus scyllaris</i>)	Grey card experiment, food training	Marshall <i>et al.</i> (1996)	Yes			
Insects						
Grasshopper (<i>Phaeoba</i> sp.)	Broadband stimuli, phototaxis	Kong <i>et al.</i> (1980)	Ind.			Reviews: Mazokhin- Porshnyakov (1969); Menzel (1979) Eye bands with different screening pigments
Aphid (<i>Myzodes persicae</i>)	Monochromatic stimuli, oviposition	Moericke (1950)	Yes			

Honeybee (<i>Apis mellifera</i>)	Grey card experiment	von Frisch (1914)	Yes			
	Monochromatic stimuli, food training	Kühn (1927)	Yes			First evidence for UV sensitivity in bees
	Grey card experiment, food training	Lotmar (1933)	Yes			
	Grey card experiment *, food training	Mazokhin-Porshnyakov (1969)	Yes			* Use of different shades of colour instead of grey
	Spectral sensitivity, food training	Helversen (1972)		3	2 *	* Models: Brandt & Vorobyev (1997); Vorobyev & Osorio (1998)
	Wavelength discrimination, food training	Helversen (1972)		3		
	Colour mixture, food training	Daumer (1956)	Yes	3		
Wasp (<i>Polybia occidentalis</i>)	Multidimensional scaling (MDS) *, Food training	Backhaus (1991)	Yes *	3	2	* First colour discrimination model in bees (see Sections V2.c and VI.3)
	Grey card experiment, food training	Shafir (1996)	Yes			
	Grey card experiment, food training	Beier & Menzel (1972)	Yes	*		* Proof that no L receptor is involved
German wasp (<i>Paravespula germanica</i>)	Grey card experiment, food training	Schremmer (1941 b)		*		* Proof that no L receptor is used
Hornet (<i>Vespa rufa</i>)						
Desert ant (<i>Cataglyphis bicolor</i>)	Monochromatic stimuli, food training	Wehner & Toggweiler (1972)	Yes			
	Eight species of hymenoptera	Colour discrimination *	Chittka <i>et al.</i> (1992)	Yes *	3	* Model: a modification of the model by Backhaus (1991)
Hummingbird hawkmoth (<i>Macroglossum stellatarum</i>)	Grey card experiment, food training	Knoll (1922)	Yes			
	Monochromatic stimuli, spontaneous choices, feeding	Kelber (1997)	Ind.			
	Monochromatic stimuli, food training	Kelber & Hénique (1999)	Yes	*		* Proof that no L receptor is used
Striped hawkmoth (<i>Hyles livornica</i>)	Grey card experiment, food training	Knoll (1926)	Ind.			Few observations
Gamma fly (<i>Autographa gamma</i>)	Grey card experiment, food training	Schremmer (1941 a)	Yes			
Swallowtail butterfly (<i>Papilio xuthus</i>)	Grey card experiment	Kinoshita <i>et al.</i> (1999)				
Orchard butterfly (<i>Papilio aegaeus</i>)	Monochromatic stimuli, food training	Kelber & Pfaff (1999)	Yes	*		* L receptor used for colour vision
	Paper colours *, spontaneous choices, oviposition	Kelber (1999)	Yes	≥ 3	1 *	* Model calculation

Table 2 (*cont.*)

Animal species	Method	Reference	q1	q2	q3	Comments
Insects (<i>cont.</i>)						
Tortoiseshell (<i>Aglaia urticae</i>), peacock butterfly (<i>Inachis io</i>), fritillary (<i>Argynnis paphia</i>), cabbage white (<i>Pieris brassicae</i>), brimstone (<i>Gonepteryx rhamni</i>) <i>Heliconius erato</i>	Grey card experiment, spontaneous choices, feeding	Ilse (1928)	Ind.			
Zebra (<i>Heliconius charotoni</i>)	Grey card experiment food training	Swihart (1971)	Yes			Colour learning but no intensity learning
Cabbage white (<i>P. brassicae</i>)	Monochromatic stimuli, spontaneous choices, feeding and oviposition	Scherer & Kolb (1987)	Yes	4	1 *	* Model: Kelber 2001
Tortoiseshell caterpillars (<i>Aglaia urticae</i>)	Grey card experiment, phototaxis	Süffert & Götz (1936)	Yes			
Blowfly (<i>Lucilia cuprina</i>)	Grey card experiment, spontaneous choices, feeding	Fukushi (1990)	Ind.			
	Wavelength discrimination, spontaneous choices, feeding	Troje (1993)	Yes			Model proposed
Olive fruit fly (<i>Dacus oleae</i>)	Grey card experiment, spontaneous choices, oviposition	Prokopy <i>et al.</i> (1975)	Yes	2	1 *	* Model: Kelber 2001
Bee fly (<i>Bombylius fuliginosus</i>)	Grey card experiment, feeding	Knoll (1921)	Yes			
Drone fly (<i>Eristalis tenax</i>)	Grey card experiment, food training	Ilse (1949)	Yes			
	Grey card experiment, spontaneous choices, feeding	Kugler (1950)	Yes			
	Monochromatic stimuli, spontaneous choices, feeding	Lunau & Wacht (1994)	Yes	2	1 *	* Model: Kelber 2001
Vertebrates						
Fishes						
Minnnow (<i>Phoxinus laevis</i>)	Grey card experiment, spontaneous colour change	von Frisch (1912, 1913 <i>a</i>)	Yes			
	Grey card experiment food training	von Frisch (1913 <i>b</i>)	Yes			
	Wavelength discrimination, food training	Wolff (1925)	Ind.	4 *		* Evidence for a VS receptor

Wrasse (<i>Crenilabrus melops</i>)	Grey card experiment, spontaneous colour change	von Frisch (1913 <i>a</i>)	Ind.		
Stickleback (<i>Gasterosteus aculeatus</i>)	Monochromatic stimuli, food training	Schiemenz (1923)	Yes	*	* Indication for a VS receptor
	Grey card experiment, escape response	Schiemenz (1923)	Yes		
Tench (<i>Tinca tinca</i>), golden orfe (<i>Idus melanotus</i>)	Grey card experiment	Burkamp (1923)	Yes		
Goldfish (<i>Carassius auratus</i>)	Spectral sensitivity, heart rate conditioning, bright light	Beauchamp & Rowe (1977)	Ind.	4 *	* The high sensitivity in UV was measured but taken as 'aberrant'
	Spectral sensitivity, respiration rate conditioning in dim light	Powers & Easter (1978 <i>a</i>)	Ind.	2 *	* Rod and L cone colour vision in dim light for respiration rate conditioning
	Monochromatic lights, respiration rate conditioning in dim light	Powers & Easter (1978 <i>b</i>)	Yes	2 *	* Rod and L cone colour vision in dim light for the task
	Spectral sensitivity, food training, dim light	Neumeyer & Arnold (1989)	Ind.	3 *	* Only VS, S and M cones contribute to colour vision for the task under dim light
	Spectral sensitivity, food training, bright light	Neumeyer (1984)	Ind.		
	Colour matching, food training	Neumeyer (1985, 1992)	Yes	4 *	* First direct evidence for tetrachromatic colour vision in an animal
	Wavelength discrimination, food training	Neumeyer (1985, 1986)	Yes*	4	* Maxima of discrimination curve are narrower than those of receptor curves
Amphibians					
Common toad (<i>Bufo bufo</i>)	Grey card experiment, dishabituation of turning response	Meng (1958)	Yes		
	Grey card experiment, mate choice	Gnyubkin <i>et al.</i> (1975) Kondrashev <i>et al.</i> (1976) Dimentman <i>et al.</i> (1978)	Yes		

Table 2 (*cont.*)

Animal species	Method	Reference	q1	q2	q3	Comments
Amphibians (<i>cont.</i>)						
Grey toad (<i>Bufo viridis</i>)	Grey card experiment, feeding response	Falzman & Bastakov (1999)	Yes			
	Grey card experiment, mate choice	Orlov & Maximov (1982)	Yes	3	1 *	* Model: Losev & Maximov (1982) (see Section V.2c)
Arrow poison frog (<i>Dendrobates pumilo</i>)	Broadband stimuli, spontaneous mate choice	Summers <i>et al.</i> (1999)	Ind.			
Common frog (<i>Rana temporaria</i>)	Broadband stimuli, phototaxis	Muntz (1962, 1963)	Yes			
16 species of frog and toad (<i>Scaphiopus</i> sp., <i>Rana</i> spp., <i>Bufo</i> spp., <i>Hyla</i> spp., <i>Limnaoedus</i> sp., <i>Pseudacris</i> sp., <i>Acris</i> sp.)	Broadband stimuli, phototaxis	Jaeger & Hailman (1971); Hailman & Jaeger (1974)	Yes			
Common frog (<i>Rana temporaria</i>), Crested newt (<i>Triturus cristatus</i>), Fire salamander (<i>Salamandra salamandra</i>)	Grey card experiment, food training	Kasperczyk (1971)	Yes			
Fire salamander (<i>S. salamandra</i>), newts (<i>T. alpestris</i> , <i>T. cristatus</i> , <i>T. vulgaris</i>)	Grey card experiment, prey catching*	Himstedt (1972)	Yes			* Motion vision involved but object detection task used for tests
Fire salamander (<i>S. salamandra</i>)	Spectral sensitivity, detection of moving prey dummy	Przyrembel <i>et al.</i> (1995)	Ind.	3 *		* Deduced from the number of maxima in sensitivity curve
Caspian terrapin (<i>Clemmys caspica</i>)	Wavelength. discrimination, food training	Wojtusiak (1932)	Ind.	4 *		* Three maxima in discrimination curve
	Grey card experiment, food training	Wojtusiak (1932)	Yes			
Giant turtles (<i>Testudo elephantopus</i> , <i>T. gigantea</i>)	Monochromatic lights, food training	Quaranta (1952)	Yes			
Freshwater turtle (<i>Pseudemys scripta</i>)	Spectral sensitivity, food training	Neumeyer & Jäger (1985)	Ind.	3 *		* Deduced from four maxima in the sensitivity curve
	Wavelength discrimination, food training	Arnold & Neumeyer (1987)	Yes	4 *		* Gap in wavelength discrimination function due to oil droplet absorption

Sand lizard (<i>Lacerta agilis</i>)	Grey card experiment, food training	Wagner (1932)	Yes			
Anole lizard (<i>Anolis cristellatus</i>)	Moving coloured stimuli, visual fixation reflex	Fleishman & Persons (2001)	Yes			
Birds						
<i>Columba livia</i> (pigeon)	Spectral sensitivity, food training	Remy & Emmerton (1989)	Yes	4	2*	Review: Varela <i>et al.</i> (1993) * Model Vorobyev & Osorio (1998)
	Wavelength discrimination	Emmerton & Delius (1980)	Ind.		4	
	Colour mixture	Palacios <i>et al.</i> (1990); Palacios & Varela (1992)	Ind.			
Pekin robin (<i>Leiothrix lutea</i>)	Spectral sensitivity, food training	Maier (1992)	Yes	4	2*	* Model Vorobyev & Osorio (1998)
Pied flycatcher (<i>Muscicapa hypoleuca</i>)	Grey card experiments, nest recognition	Derim-Oglu <i>et al.</i> (1987); Derim-Oglu & Maximov (1994)	Yes	*		* Colour discrimination but generalization over brightness, VS receptor is used
Great tit (<i>Parus major</i>)	Tree	Derim-Oglu & Maximov (1994)		*		* VS receptor is used for colour discrimination
sparrow (<i>Passer montanus</i>)	Grey card experiments, nest recognition					
Budgerigar (<i>Melopsittacus undulatus</i>)	Grey card experiment, food training	Plath (1935)	Yes			
Chick males (<i>Gallus gallus</i>)	Grey card experiment with adjusted light spectra, food training	Osorio <i>et al.</i> (1999)	Yes	4	*	* Colour discrimination was possible with each pair of two receptors (see Section V.2c)
Jay (<i>Garullus glandarius</i>)	Grey card experiment food training	Hertz (1928)	Yes			
Hummingbird (<i>Archilochus alexandri</i>)	Wavelength discrimination, food training	Goldsmith <i>et al.</i> (1981)	Yes	*		* VS receptor used for colour vision
Tawny owl (<i>Strix aluco</i>)	Grey card experiment, food training	Ferens (1947)	Yes			
	Monochromatic stimuli, food training	Martin (1974)	Yes			
Little owl (<i>Athene noctua</i>)	Grey card experiment, food training	Meyknecht (1941)	Yes			
Mammals						
Possum (<i>Didelphis virginiana</i>)	Monochromatic stimuli, food training	Friedman (1967)	Yes			Review: Jacobs (1993)
Tammar wallaby (<i>Macropus eugenii</i>)	Monochromatic stimuli, food training	Hemmi (1999)	Yes			
	Neutral point, food training	Hemmi (1999)	Yes	2		

Table 2 (*cont.*)

Animal species	Method	Reference	q1	q2	q3	Comments
Mammals (<i>cont.</i>)						
Tree shrew (<i>Tupaia belangeri</i>)	Spectral sensitivity, food training	Jacobs & Neitz (1986)	Yes	2	1 *	* Model Vorobyev & Osorio (1998)
Tree shrew (<i>Tupaia glis</i>)	Neutral point, food training	Jacobs & Neitz (1986)	Yes	2		
	Spectral sensitivity, food training	Polson (1968)	Yes	2		
Dog (<i>Canis lupus familiaris</i>) *	Grey card experiment, food training	Orbeli (1909)	Yes			* See Rosengren (1969), for additional references on dog colour vision
	Grey card experiment, food training	Rosengren (1969)	Yes			
	Spectral sensitivity, food training	Neitz <i>et al.</i> (1989)				
	Wavelength. discrimination, food training	Neitz <i>et al.</i> (1989)				
	Neutral point, food training	Neitz <i>et al.</i> (1989)		2		
Wolf (<i>Canis lupus</i>)	Grey card experiment, food training	Eisfeldt (1967)	Yes			
Cat (<i>Felis sylvestris</i>) *	Grey card experiment, playing behaviour	Buchholtz (1952)	Yes			* See Autrum & Thomas (1973) and Jacobs (1981), for more references on cat colour vision.
	Monochromatic stimuli, food training	Bonaventure (1961)	Yes			
	Coloured lights, food training	Sechzer & Brown (1964)	Yes			
	Coloured lights, food training	Mello & Peterson (1964)	Yes			
	Spectral sensitivity, food training	Loop <i>et al.</i> (1987)			Yes	2 **
	Adjusted spectra, food training	Kezeli <i>et al.</i> (1987)	Yes		3 **	
Mongoose (<i>Mungos ichneumon</i>)	Grey card experiment, food training	Dücker (1957)	Yes			
Indian civet (<i>Viverricula indica</i>)	Grey card experiment, food training	Dücker (1957)	Yes			
<i>Sciurus vulgaris</i> (Common squirrel)	Grey card experiment, food training	Meyer-Oehme (1957)	Yes			
Grey squirrel (<i>Sciurus griseus</i>) Fox squirrel (<i>S. niger</i>)	Wavelength discrimination, food training	Jacobs (1976)	Ind.	2		

Antelope ground squirrel (<i>Ammospermophilus leucurus</i>)	Monochromatic stimuli, food training	Crescitelli & Pollack (1972)	Yes	2		
Ground squirrel (<i>Spermophilus tridecemliatus</i> , <i>S. mexicanus</i> , <i>S. lateralis</i>)	Spectral sensitivity, white point, wavelength discrimination, food training	Jacobs (1978)	Yes	2		
Prairie dog (<i>Cynomys ludovicianus</i>)						
Ground squirrel (<i>Spermophilus beecheri</i>)	Spectral sensitivity, food training	Jacobs (1993)	Yes	2	1 *	Model Vorobyev & Osorio 1998
Rat (<i>Rattus norvegicus</i>)	Monochromatic stimuli, food training	Walton & Bornemeier (1938)	Yes			
	Wavelength discrimination, food training	Jacobs & Neitz (1985)				
Manatee (<i>Trichechus manatus</i>)	Grey card experiment, food training	Griebel & Schmid (1996)	Yes			
Sea lion (<i>Zalophus californicus</i>)	Grey card experiment, food training	Griebel & Schmid (1992)	Yes *			* Peichl <i>et al.</i> (2001) showed that sea lions and seals have only one cone type, the basis of their colour discrimination ability therefore remains uncertain.
Fur seal (<i>Arctocephalus</i> sp.)	Grey card experiment, food training	Busch & Dücker (1987)	Yes *			
Horse (<i>Equus equus</i>)	Grey card experiment, food training	Grzimek (1952)	Yes			
Zebu (<i>Bos indicus</i>)	Grey card experiment, food training	Hoffmann (1952)	Ind.			

V. TESTS OF COLOUR VISION

Von Frisch (1914) successfully differentiated the uses of chromatic and achromatic signals by bees. Although bees and birds do not usually learn achromatic signals, mammals usually have comparatively poor colour vision, and may prefer to use achromatic cues (Jacobs, 1981, 1993). For that reason, many researchers failed to train mammals like cats or dogs to discriminate colours, and until the 1960s it was not certain if they could see colour (Rosengren, 1969; Jacobs, 1981).

An early method of excluding achromatic information was to present an animal with two stimuli of different colours that were matched in brightness, meaning that intensities were adjusted so they appeared equally bright. Early work used human brightness, but it was recognized that the animal's spectral sensitivity could differ from ours, and needed to be measured. Stimulus intensities could then be adjusted appropriately for the test species (see Section V.2). There are several difficulties with this approach. First, spectral sensitivity may depend upon behavioural context (Jacobs 1981; Neumeyer, 1991). The spectral sensitivity of goldfish, for example, differs depending upon whether they are trained to prefer a coloured target over a dark one, or a dark target over a coloured one (Neumeyer, 1991). More fundamentally, for light-adapted eyes behavioural spectral sensitivities often are mediated by chromatic, not achromatic mechanisms. Adjusting intensities according to these sensitivities does not then exclude achromatic signals (see Fig. 5; Section VI.3). Finally, where two or more receptor types contribute to the achromatic mechanism, and are randomly arranged (as in primates) spectral differences can locally lead to an achromatic signal even if the intensities are properly adjusted for the average. Given the difficulties of excluding achromatic signals, a more practical method is to make intensity unreliable by testing discrimination for a range of relative intensities, or by adding intensity noise.

Colour vision tests must refer to a specific behavioural context. In dim light, many vertebrates lack colour vision, and directional motion vision is often based on signals from one spectral type of receptor (Schlieper, 1927; bees: Lehrer, 1993; goldfish: Schaerer & Neumeyer, 1996). Behaviours tested include feeding, mating, escape, phototaxis, movement detection, camouflage, nest orientation and oviposition. Both spontaneous and learned behaviour can be studied. However, the most usual

way of testing colour vision is by associative learning with a food reward. Here, we list general methods according to the stimulus design and give examples of the behavioural context in which these have been used. Table 2 gives an extensive, but still incomplete list, of experiments (for older reviews see Mazokhin-Porshnyakov, 1969; Autrum & Thomas, 1973; Menzel, 1979; Jacobs, 1981, 1993).

Three related methods for demonstrating colour vision are described below (Section V.1), all of which predate the knowledge of receptor sensitivities: (a) discrimination of a fixed colour from a series of grey shades; (b) discrimination of monochromatic colours, which can be changed in intensity; (c) discrimination of two broadband stimuli that can be adjusted such that either one or the other emits more photons over the entire spectrum. If an animal selects a stimulus according to its wavelength distribution it must have colour vision.

Section V.2 describes investigations that set out to study which receptors and neural mechanisms underlie colour vision. These include: (a) colour-matching experiments, the only direct test of the number of receptors; (b) discrimination tests with stimuli specially adjusted to test hypotheses on receptors; and (c) models of colour choices based on discrimination tests.

Knowledge of discrimination thresholds allows quantitative description of colour vision, and is discussed in Section VI. In recent years, quantitative models have emerged as powerful tools for understanding the biological relevance of colour discrimination.

(1) Evidence for colour vision

(a) Grey card experiments

Von Frisch's (1914) 'grey-card' experiment with bees is a convincing demonstration of colour vision. An animal learns to associate a reward with a colour, and then chooses between this colour and many shades of grey. It is assumed that at least one grey gives a sufficiently similar achromatic signal to the trained colour, so that if all are discriminable from the colour the animal is not relying on achromatic cues. Von Frisch (1913*b*) also tested European minnows (*Phoxinus phoxinus*), and his influence led to many similar studies, especially in Germany during the 1920s and 30s (Table 2).

There have been some interesting variants on the grey card method. Swihart (1971) noted that *Heliconius charitonius* butterflies cannot associate a medium shade of grey with food, always choosing

the brightest, but could learn successively two yellowish colours. Since both yellows could not both have been the brightest, the butterflies could not have been using achromatic cues. An alternative explanation is that the butterflies have a preference for yellow, and this directs their attention to the intensity of yellow objects so that they can learn the achromatic signal; but this too requires colour vision.

Apart from associative learning, spontaneous preferences have long been used to test colour vision. Ilse (1928) found that butterflies (various Nymphalidae, Papilionidae, Pieridae and Satyridae) prefer both blue and yellow to any achromatic shade including white. On the other hand when hermit crabs (*Eupagurus anachoretus*) select a new home they prefer achromatic shells of any intensity from black to white over blue or yellow alternatives (Koller, 1928).

Control of body coloration by fish (von Frisch, 1913a) and crustaceans also uses colour vision. To match their background brown shrimps (*Crangon vulgaris*) selectively dilate red, yellow and sepia-brown pigmented chromophores. In tanks surrounded by yellow paper the yellow pigment was more expanded than with any shade of grey surround (Koller, 1927). In contrast, cuttlefish (*Sepia officinalis*) seem to be colour blind when selecting body pattern on coloured gravels (Marshall & Messenger, 1996).

Amphibians have multiple types of spectral receptor, but are often difficult to train by operant conditioning, so alternative methods are needed to test colour vision. For example, toads (*Bufo bufo*) jump towards coloured cards that resemble prey, but the response habituates. Meng (1958) found that toads react again if they see a novel colour, but not a different shade of grey. The urodeles *Salamandrasalamandra* and *Triturus* spp. also respond to moving prey, and to test them Himstedt (1972) used an elongated window divided into two fields that differed in colour or intensity. The border separating the fields moved sinusoidally. A jump towards the target indicated that the amphibian saw the border. The salamanders reacted much more strongly to a border between a coloured and any grey field than they did to a border between two similar shades of grey indicating that they used colour to make the discrimination. Fleishman & Persons (2001) used a similar method, testing responses of lizards (*Anolis cristellatus*) to movement of coloured cards that resembled the displays of conspecifics.

A variation of the grey card technique is to add intensity noise to the training colours, making brightness an unreliable cue. This technique is

widely used when testing human colour vision, and is a feature of Ishihara's (1917) tests. Such patterns can be displayed on a monitor (which excludes ultraviolet) or printed out as paper stimuli. Osorio *et al.* (1999b) trained chicks to find food in small paper containers covered with such patterns, and demonstrated tetrachromatic colour vision in this bird.

(b) Monochromatic stimuli

Monochromatic stimuli can be precisely defined in physical terms, and thus have long been used in human psychophysics (e.g. Maxwell, 1860) and with animals. If changes in relative intensity of two monochromatic lights do not influence an animal's choice, it must be using colour vision. Monochromatic (or narrow-band) lights can be produced with monochromators, interference filters, or light-emitting diodes (LEDs). There are three basic procedures:

(i) If the spectral sensitivity of a species is known, the intensities of the stimuli can be adjusted to give equal achromatic signals, but other than with humans this is not easy. In a careful study, Powers & Easter (1978b) classically conditioned goldfish (conditioned stimulus: respiration rate; unconditioned stimulus: electric shock) to discriminate lights of 532 nm and 636 nm whose intensities were adjusted according to a previously determined detection threshold (using separate curves for photopic and scotopic sensitivities). To ensure that discrimination was not made by achromatic cues, both lights were varied over 0.5 log units. Goldsmith *et al.* (1981) used a similar method to test spectral discrimination by black-chinned hummingbirds (*Archilochus alexandri*), with stimulus intensities adjusted for the photopic sensitivity of the pigeon. This study demonstrated hummingbird colour vision, because they did not discriminate stimuli differing only in intensity.

(ii) When spectral sensitivity is unknown – as is usual – training can be done using equal (or arbitrarily chosen) physical intensities. After training, intensities in unrewarded tests have then to be varied over an (often inconveniently) large range of several log units (e.g. Quaranta, 1952 for giant tortoises, *Testudo* spp.; Kelber & Pfaff, 1999 for the butterfly *Papilio aegerus*).

(iii) In operant conditioning, training can involve intensity variations, and no subsequent unrewarded tests are needed. This was how Schiemenz (1923) demonstrated that European minnow and three-spined stickleback (*Gasterosteus aculeatus*) see UV light

and have colour vision. Operant training with narrow-band lights is commonly used with mammals (Table 2; Jacobs 1981, 1993). For the tammar wallaby (*Macropus eugenii*), Hemmi (1999) adjusted stimulus intensities to give equal signals for the L cone, and went on to vary both rewarded and unrewarded training intensities widely. It was clear that the wallabies have colour vision because they preferred the rewarded colour to black, but black to the colour that was unrewarded during training.

Spontaneous preferences for food sources or oviposition substrates have been studied using monochromatic lights in butterflies (Scherer & Kolb, 1987) and hoverflies (Lunau & Wacht, 1994). Narrowband spectral stimuli have long been used to study *Daphnia* sp. phototaxis with controversial results (Koehler, 1924), but a recent careful study (Storz & Paul, 1998) shows that *Daphnia magna* phototaxis is specific to wavelength, and independent of intensity, over a large intensity range.

(c) Broadband stimuli at different intensities

When Lubbock (1888) studied *Daphnia* sp. he first found that they are positively phototactic (up to some intensity limit), and then that they prefer a light source filtered with a yellow filter to the unfiltered alternative. As the unfiltered light had a higher intensity at all wavelengths, Lubbock (1888) could conclude that the *Daphnia* sp. have colour vision, preferring yellow to white light. He speculated that this preference arises because the algae that *Daphnia* sp. eat colour water yellow. Subsequent experiments on phototaxis in frogs (*Rana* spp.), toads and grasshoppers (*Phaeoba* sp.) resembled Lubbock's, trading a preference for a particular waveband against a general preference for high intensities (Muntz, 1962; Jaeger & Hailman, 1971; Kong *et al.*, 1980). Unlike *Daphnia* sp., both grasshoppers and amphibians preferred short to long wavelengths. For frogs, Muntz's (1962) critical test was to present the more attractive colour together with a mixture of this light and the less attractive colour. The mixture then had a higher intensity than the preferred colour. Since the less intense stimulus was chosen in these experiments, it was concluded that a chromatic mechanism overrode the preference for the more intense stimulus. Jaeger & Hailman (1971), on the other hand, showed that even when the stimulus with the less attractive colour was more intense than the other at all wavelengths it remained less attractive. A similar stimulus design, but with

operant conditioning, was used successfully to show that dogs have colour vision (Orbeli, 1909).

(2) Tests of visual mechanisms

We now turn from simple demonstrations of colour vision to tests of the underlying physiological mechanisms. Firstly, we discuss colour matching as a direct test of the number of receptors used for colour vision, which can be done without knowledge of receptor spectral sensitivities, and secondly tests of receptor inputs to visual behaviour based on knowledge of receptor sensitivities.

(a) Colour matching

Colour matching is the direct test for dimensionality of colour vision. It is based on the principle (see Section II.2) that if n receptor signals are compared in colour vision, any spectral stimulus can be matched with a specific mixture of n primaries. For a dichromat, a mixture of two primary spectra can match white light, a trichromat requires three and so on.

Following Maxwell (1860), colour matching has been used widely with mammals, which are di- or trichromatic (Jacobs, 1981, 1993). Things are more complicated with increasing numbers of receptors, but colour-matching experiments have shown that honeybees are trichromats (Daumer, 1956), and goldfish and pigeon tetrachromats (Neumeyer, 1985, 1992; Palacios *et al.*, 1990; Palacios & Varela, 1992). It seems unrealistic to test butterflies for possible pentachromatic vision (Arikawa, Inokuma & Eguchi, 1987), and impossible to test a mantis shrimp with 12 spectral types of photoreceptors (Cronin & Marshall, 1989; Marshall & Oberwinkler, 1999). Even with goldfish, a two-step procedure was applied (Neumeyer, 1992). First, three lights were used to match 'human-white' light missing UV and second, it was shown that goldfishes can discriminate UV-containing white from UV-missing white.

A special case of colour matching can be used to demonstrate dichromacy (Fig. 2A; Jacobs, 1981). For a dichromatic eye all colours are represented by quantum catches of two receptor types. For any broadband stimulus, including a white one, it is possible to find a wavelength and intensity of monochromatic light, which will match the quantum catches of both receptors. Thus, a dichromat confuses light of a specific wavelength – called the neutral point – with white light (Jacobs, 1981, 1993; Hemmi, 1999).

(b) *Discrimination of specially adjusted stimuli*

If photoreceptor spectral sensitivities are known photoreceptor quantum catches can be calculated (see Section II.3), and it is possible to design stimuli giving known quantum catches in the different receptor types. For instance, two stimuli can be chosen to give equal quantum catches in one or even two spectral types of receptor. If an animal is still able to discriminate the two colours, this is good evidence that an additional receptor type is involved.

This approach has provided evidence for trichromacy in cats, which are commonly thought to be cone dichromats (Loop, Millican & Thomas, 1987; Jacobs, 1993). Electrophysiological evidence indicates that in photopic conditions cat ganglion cells receive input from three spectral types of photoreceptor, maximally sensitive at 450 nm, 555 nm (typical mammalian S and L cones), and at 500 nm, which is typical for rods (Ringo *et al.*, 1977; Crocker *et al.*, 1980). To find out whether the 500 nm receptor is used for colour vision, Kezeli *et al.* (1987) trained cats to discriminate a group of green from a group of purple stimuli. Both groups of colour occupied the same area in the cat's two-dimensional dichromatic colour space given by S and L cones, but differed substantially for a putative 500 nm receptor. To take account of differences between calculated and actual cone sensitivities, stimulus colours were varied so that for any reasonable hypothesis about S and L sensitivities a dichromat would fail to discriminate at least some of the green stimuli from the purple. In fact, cats reliably discriminated purple from green, implicating a third input. Kezeli *et al.* (1987) argued for a 500 nm cone type (photopic) receptor, but rods cannot be excluded.

Where spectral sensitivities of receptors are known and do not overlap too much it is possible to adjust illumination so that only a subset of receptors are active in an experiment. Osorio *et al.* (1999a) used this method with domestic chicks, choosing stimuli and illumination so that only two receptor types were active in each experiment. They found that chicks probably use all four single cone types for colour vision, and that the receptors drive at least three chromatic mechanisms.

(c) *Receptor-based models of colour choices*

Given receptor sensitivities it is possible to establish the receptor inputs to visual responses and the underlying achromatic and/or chromatic mechanisms. Specifically, the strength of a behavioural

response can be related to receptor signals by general linear models.

One such model has been used to study mate choice in toads (*Bufo viridis*). Relative preferences for a series of pairs of coloured toad-like objects were measured in dual-choice tests (Orlov & Maximov, 1982). Colour preferences were fitted by a model (Losev & Maximov, 1982), which assumed that preference (X) depends on a weighted sum of receptor quantum catches. It was found that excitation of the 'green' rods (see Table 1) increases attractiveness, while excitation of long (L) and medium (M) cones decreases it. A linear model nicely explained the preferences:

$$X = 0.1 q_{SR} - 0.22 q_M - 0.1 q_L, \quad (5)$$

where q_{SR} , q_M and q_L are quantum catches of the toad's green rod, M and L cones, respectively.

Backhaus (1991) trained bees to coloured stimuli and tested them with several similar colours simultaneously. A multidimensional scaling procedure was used, and choice proportions assumed to depend on the distance in colour space, ΔS , between the stimuli, which in turn was dependent on the linear combinations of receptor signals. Two scales, A and B , were needed to describe the data. The distance is given by:

$$\Delta S = |A| + |B|, \quad (6)$$

where

$$A = -9.86 E_S + 7.70 E_M + 2.16 E_L, \quad (7)$$

$$B = -5.17 E_S + 20.25 E_M - 15.08 E_L, \quad (8)$$

and $E_i = q_i / (1 + q_i)$ denotes the receptor excitations, which are related by non-linear transformations to receptor quantum catches q_i . The scales A and B describe chromatic mechanisms, because receptor signals are combined with opposite signs.

Finally, Kelber (1999, 2001) studied oviposition in a butterfly (*Papilio aegaeus*), and found that preferences amongst a number of colours are described by a model assuming that choice proportions depend on only one linear mechanism (η) receiving signals from three receptor types such that:

$$\eta = -1.24 q_S + q_M - 0.77 q_L. \quad (9)$$

VI. MODELLING THRESHOLDS FOR COLOUR DISCRIMINATION

Section V discussed the existence of colour vision and studies based on comparing relative preferences for different colours. Models have been found to be

helpful in describing colour vision mechanisms in various behavioural contexts. If models fit the behavioural data well, we can then look for a physiological correlate of the postulated neural mechanisms. At the same time, quantitative models can be used to test hypotheses about the evolution and the ecological value of specific colour vision systems.

An advantage of studying thresholds for colour discrimination is that it is generally easier to establish whether or not an animal can discriminate two colours than to ask how different they look. Also, non-linearities are usually less important near threshold. This makes it easier to fit quantitative models to behavioural data, which may reveal the neural mechanisms underlying colour vision and how they limit behavioural judgements.

(1) Measuring thresholds

Generally, it is more difficult to measure accurate thresholds for animals than for humans, thus behavioural thresholds have been measured only in a small number of species (see Table 2), including several mammals (Jacobs, 1981, 1993), honeybees (von Helversen, 1972) and goldfish (Neumeyer, 1984, 1985, 1986, 1992). The measurements require precise stimulus intensities and spectra, such as monochromatic lights. Thresholds are usually measured in one of two ways, either as spectral sensitivity or as wavelength discrimination. Spectral sensitivity is given by the minimal intensity of monochromatic light that can be detected, on either a dark or an achromatic background, sensitivity being the inverse of threshold intensity. In physiological measurements, absolute sensitivity is often measured; in behavioural tests, an achromatic background is more appropriate since many animals would not respond in complete darkness. In effect the task is to detect very unsaturated colours. Wavelength discrimination ($\Delta\lambda/\lambda$ function) is defined as the smallest wavelength difference that can be discriminated using two monochromatic stimuli. Monochromatic stimuli might be discriminated by both chromatic and achromatic signals, but studies of wavelength discrimination are generally intended to isolate chromatic mechanisms, in which case stimulus intensities are adjusted to remove achromatic signals, although this adjustment is difficult (Section V.1*b*).

On the whole, spectral sensitivity is better suited to quantitative analysis than wavelength discrimination. Firstly, spectral sensitivity gives thresholds about one point in colour space (normally the

achromatic point), while wavelength discrimination gives thresholds about many points. This means that modelling spectral sensitivity does not require assumptions about changes of threshold values across colour space (Appendix A; Section VI.3). Secondly, the highly saturated colours used for wavelength discrimination may saturate opponency mechanisms, as they do in humans (Mollon & Estévez, 1988). Saturation introduces non-linearities, which complicates modelling.

(2) Interpretations of the shapes of threshold sensitivity curves

Data on discrimination can give information about the mechanisms of colour vision. Early analysis of behavioural spectral sensitivity and wavelength discrimination asked questions about receptor mechanisms, rather than subsequent neural processing (von Helversen, 1972; Maier, 1992). These interpretations assumed that: (i) local maxima of behavioural spectral sensitivity correspond to maxima of receptor sensitivities; and (ii) wavelength discrimination is best where the sensitivities of receptors overlap, i.e. midway between receptor sensitivity peaks. The number of receptors, and their spectral tuning can then be inferred from spectral sensitivity and wavelength discrimination functions. In honeybee, goldfish and turtle this method has allowed determination of the number of receptors involved in colour vision, before the corresponding photoreceptors were directly recorded (Daumer, 1956; Neumeyer, 1984, 1985; Neumeyer & Jäger, 1985). Bees have three maxima in their spectral sensitivity curve and two minima in the wavelength discrimination curve indicating that they use three receptor types. Goldfish and turtle have four maxima in their spectral sensitivity curve and three minima in their wavelength discrimination functions, which indicated that they had a fourth VS receptor, which was then unknown (Neumeyer, 1985, 1986, 1992; Neumeyer & Jäger, 1985). The UV maximum in spectral sensitivity had previously been attributed to the β -peak of the other (S, M and L) visual pigments (Beauchamp & Rowe, 1977).

As well as identifying receptor types, behavioural spectral sensitivities (without quantitative modelling) can implicate neural interactions between receptor outputs. The simplest possibility is that receptor signals from two stimuli (Fig. 1, stage 3) are compared without opponency (Fig. 1B). This predicts that peaks of the behavioural spectral sensitivity curves should be at least as broad as the receptor

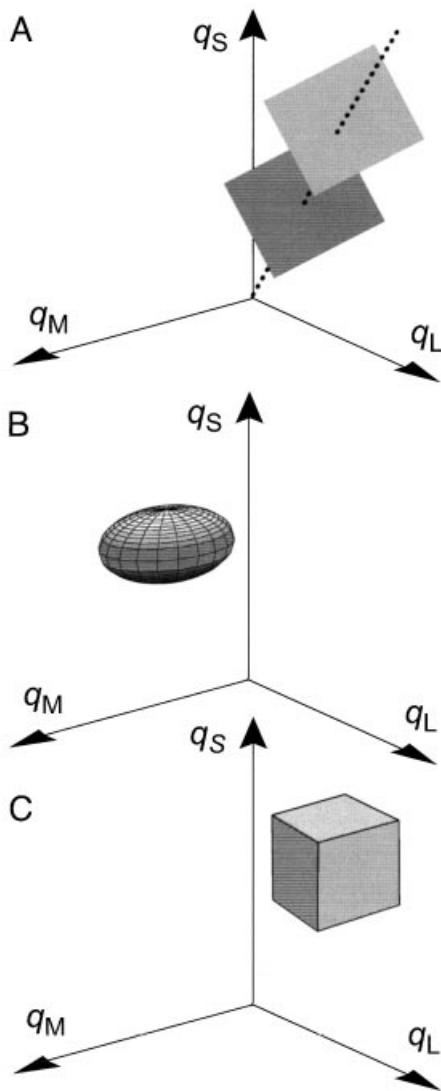

Fig. 3. Diagrams of contours of equal colour discriminability in trichromatic receptor space. Different contours are predicted by three models that have been used to fit experimental data (Fig. 5; Brandt & Vorobyev, 1997). The axes of the space correspond to quantum catches of short (S), medium (M) and long (L) wavelength-sensitive receptors. (A) One achromatic mechanism is used for colour discrimination, where the distance in colour space ΔS is given by $\Delta S^2 = (k_S \Delta q_S + k_M \Delta q_M + k_L \Delta q_L)^2$. The three positive coefficients (i.e. k_S , k_M , k_L) denote the weights of the inputs of receptors to a mechanism, that might be deduced by fitting the model to experimental data (see Fig. 5). The dotted line indicates the axis in the colour space corresponding to this mechanism. The two planes orthogonal to the mechanism's axis give contours of equal discriminability. (B) Discrimination is limited by noise in the three receptor mechanisms, with stage 2 mechanisms (see Fig. 1) absent or not adding noise. This is a Helmholtz line element. Distance in this colour space is given by $\Delta S^2 = g_{SS} \Delta q_S^2 + g_{MM} \Delta q_M^2 + g_{LL} \Delta q_L^2$. The three

peaks. Neumeyer (1984) found that peaks of the behavioural spectral sensitivity curve of goldfish were in fact narrower than those of its photoreceptors, and deduced that there are inhibitory interactions between receptor signals (Fig. 1A, stage 2).

(3) Metric spaces and quantitative analysis of threshold data

Helmholtz (1896) introduced quantitative modelling of thresholds (Wyszecki & Stiles, 1982). The theory assumes that discriminability of any two colours is given by their separation in some colour space, ΔS , and that the behavioural response, P_{corr} (Fig. 1, stage 4), depends on ΔS alone. Where ΔS is below a threshold value, colours are assumed to be indistinguishable. In two-alternative forced-choice tests P_{corr} can vary from 0.5 (random choice) to 1 (100% reliable choice), and threshold is usually assumed to correspond to $P_{corr} = 0.75$. It is important to note that distances (ΔS) refer to discriminability of stimuli, and say nothing about perceptual similarity of stimuli that are 100% discriminable. In a given space, the rule for calculating distance between points is called the 'metric' of the space. Different metrics make different assumptions about the processing of receptor signals (Fig. 1, stage 2), and about the comparison of neural signals corresponding to two colours (stage 3). Many models have been developed to explain human colour discrimination, some of which have been applied to animals.

A given metric model is fitted to colour discrimination data by describing a contour of equal discriminability, corresponding to a given value of P_{corr} , about each location in a colour space. That is, all points on the contour are equally well discriminated from the central colour. Different metric models predict different contours (Figs 3, 4). The

positive coefficients (i.e. g_{SS} , g_{MM} , g_{LL}) denote the components of metric tensor fitted to experimental data. A contour of equal discriminability is ellipsoidal with axes parallel to the receptor axes. (C) Discrimination is limited by the most sensitive receptor mechanism. This is an upper envelope model without interactions between receptor mechanisms. Distance in this colour space is given by $\Delta S = \text{Max}(|k_i \Delta q_i|)$, where the three positive coefficients, k_i ($i = S, M, L$), denote the sensitivities of receptor mechanisms. Contours of equal discriminability are described by a parallelepiped with sides parallel to the receptor axes.

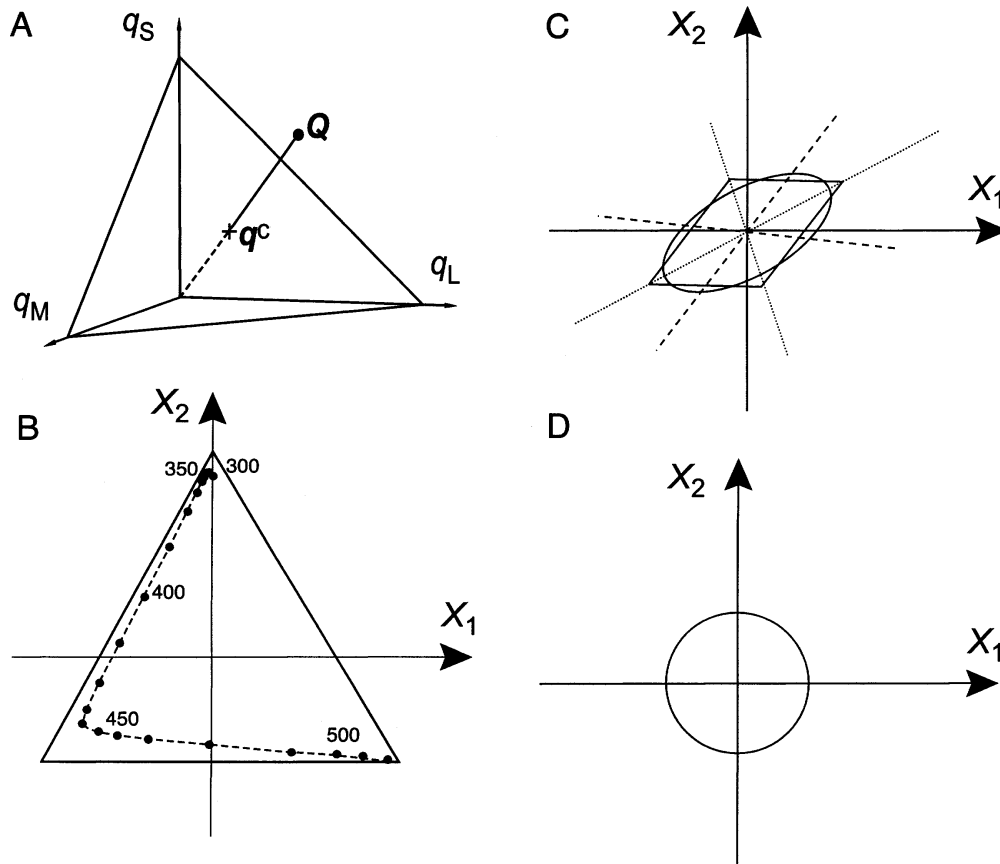

Fig. 4. Contours of equal discriminability in the chromaticity diagram of a trichromatic receptor space. (A) Colour (Maxwell) triangle (see Fig. 2B) specified by the surface in receptor space of a plane crossing receptor axes (representing quantum catches of receptors, q_S , q_M and q_L), at coordinates $(1,0,0)$, $(0,1,0)$ and $(0,0,1)$. The chromaticity locus, q^c , of a colour is the intersection of a line connecting the location of the colour in the receptor space, Q , with the origin and the triangle. (B) Spectral loci (in nm) for the honeybee in a colour triangle. See Fig. 2B. Axes X_1 and X_2 of the chromaticity diagram are given in Appendix A, equations (A3) and (A4). (C) Contours of equal discriminability plotted in the colour triangle shown in B. The ellipse is predicted by a line element model (Fig. 3B), where the distance in the colour space is: $\Delta S^2 = g_{11} \Delta X_1^2 + 2g_{12} \Delta X_1 \Delta X_2 + g_{22} \Delta X_2^2$. ΔX_i (with $i = 1, 2$) denotes the difference in the chromaticity co-ordinates, and g_{ik} (with $i, k = 1, 2$) the components of a metric tensor that can be fitted to experimental data (see Fig. 5). The parallelogram describes the contours of equal discriminability predicted by dominance and city-block metrics. The dominance metric predicts a parallelogram with its sides (and axes, dashed lines) parallel to the axes of the mechanisms mediating discrimination (e.g. receptor or colour opponent signals). Alternatively, the city block metric postulates that diagonals of the parallelogram correspond to these axes (dotted lines). A parallelogram can be defined by four parameters describing the length and orientation of its sides. Consequently, dominance and city-block metrics for trichromatic colour space have four parameters, while an elliptic model has three. (D) A chromaticity diagram corresponding to a receptor-noise-limited colour opponent model (see Section VI.3b; Appendix B). The axis X_1 is collinear to the base of colour triangle (in B), while the orientation of X_2 in the triangle plane depends on the noise in receptor mechanisms. For thresholds plotted in this chromaticity diagram (see eqns A3 and A4), the model predicts circular contours of equal discriminability.

most parsimonious approach to calculating distance, known as a line element, uses a Riemann metric, which is a generalized Euclidean metric (Wysecki & Stiles, 1982). Line element models predict ellipsoidal contours (Figs 3B, 4C). On the other hand, two types of Minkowski metric predict polygonal contours (Figs 3C, 4C), these are dominance (Sperling & Harwerth, 1971; Nuboer &

Moed, 1983) and city block metrics (Backhaus, 1991).

(a) *Inferring neural mechanisms from threshold data*

An important reason for fitting metric models to behavioural threshold data is that, in principle, they can give information about neural mechanisms at

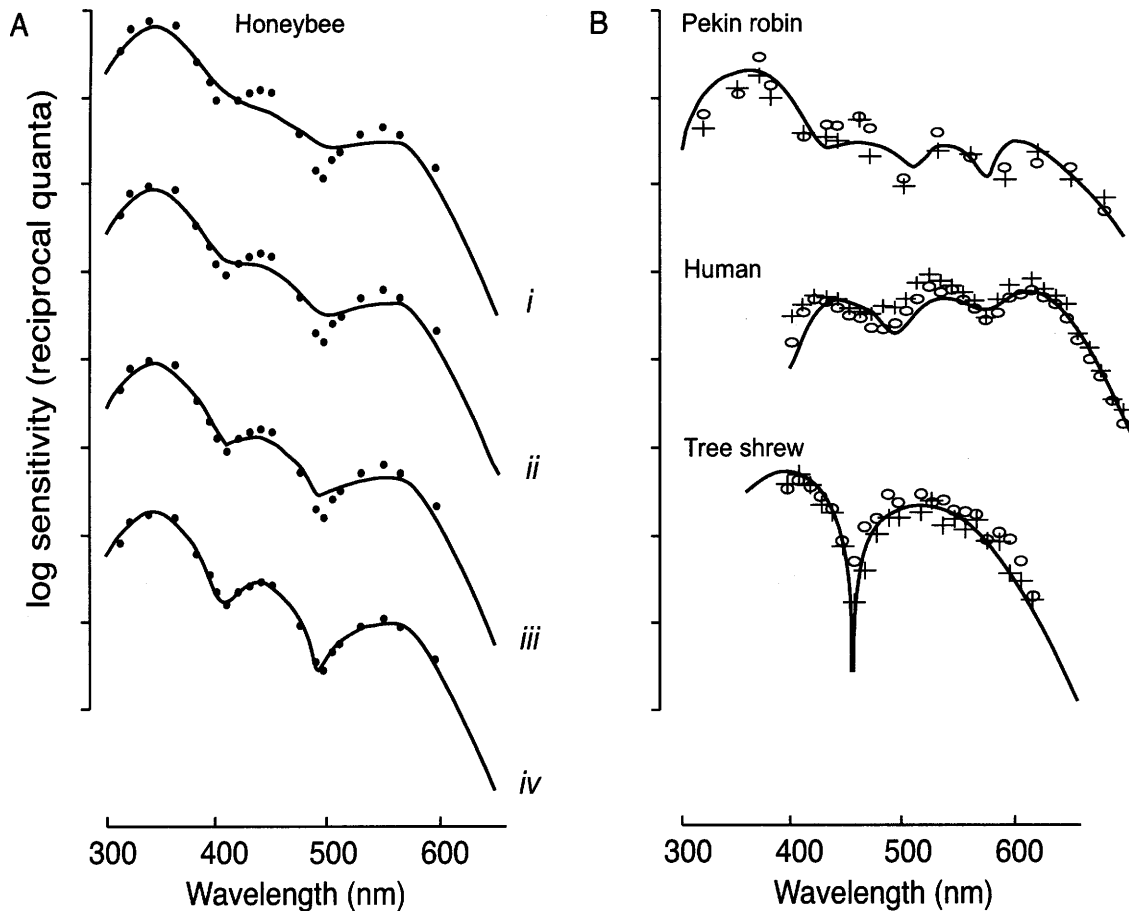

Fig. 5. (A) Predictions of models of colour discrimination (solid lines) fitted to honeybee spectral sensitivity data (filled circles; von Helversen, 1972). Geometrical interpretations of the models are illustrated in Figs 3 and 4. In each case, curves are least-squared best-fits for the model in question. (i) Discrimination by an achromatic mechanism (Fig. 3A). (ii) Discrimination limited by receptor noise without interactions between receptors (Fig. 3B). (iii) Discrimination limited by the most sensitive receptor mechanism, without interactions between receptors (Fig. 3C). (iv) Discrimination by two chromatic mechanisms (ellipse in Fig. 4C), and also dominance and city block models (parallelogram in Fig. 4C), which are indistinguishable for these data (see Section VI.3). Modified from Brandt & Vorobyev 1997. Only curve *iv* accurately describes the honeybee's colour thresholds. (B) Spectral sensitivities of three vertebrates as predicted by the receptor-noise-limited colour opponent model (as curve *iv* above; see Appendix B): a dichromat, the tree shrew (*Tupaia belangeri*; Jacobs & Neitz, 1986); a trichromat, human (Sperling & Harwerth, 1971); and a tetrachromat, Pekin robin, (*Leiothrix lutea*; Maier, 1992). Each study had two subjects, indicated by separate symbols (o, +). Curves are displaced on the vertical axis for clarity. Modified from Vorobyev & Osorio (1998).

the stage in the visual pathway that limits performance. In practice, however, different models – that might implicate quite different physiological mechanisms – often make similar predictions, so that very accurate behavioural measurements are needed to distinguish between them (Fig. 5). Sufficiently accurate measurements are hard to obtain from most animals.

A key question is whether limits to colour discrimination are imposed at the receptor stage (Fig. 1, stage 1), or by subsequent neural stages (stages 2, 3). When noise originating in the receptors limits the discriminability, the shape of threshold

contours says nothing about the receptor inputs to stage 2 mechanisms. For the models where discrimination thresholds are described by polygonal contours (dominance metric and city block metric models; Figs 3, 4), the receptor inputs to neural mechanisms can be derived from the orientation of the sides of polygons in the colour space (Brandt & Vorobyev, 1997). However, for models where the discrimination thresholds are described by ellipsoidal contours (Riemann metric; Fig. 3B), the receptor inputs to neural mechanisms cannot be derived from the orientation of the main axes of the ellipse. This is because an appropriate transformation of the colour

space maps the ellipsoid onto a sphere, whose main axes are not defined (Fig. 4D; Brandt & Vorobyev, 1997).

Ellipsoid models (Riemann metric) make very general assumptions about neural mechanisms of colour discrimination. They are valid if: (i) post-receptor neural interactions (Fig. 1, stages 2 and 3) are smooth functions, and threshold stimuli are reasonably close together in receptor space (Brandt and Vorobyev, 1997, Appendix A); or (ii) behavioural thresholds are set by noise in neural mechanisms (Vorobyev & Osorio, 1998, Appendix A).

Of the polygonal models, the dominance metric is one of the earliest models of colour vision, postulating that the receptors do not interact (stage 2 is absent; Fig. 1B). Colour vision can then be described without assuming opponent interactions. This model proposes that the most sensitive receptor mechanism is used for detection of any given stimulus. The upper envelope of the receptor sensitivities then describes behavioural spectral sensitivity (Pirenne, 1962). The dominance metric – with or without interactions between the receptors – is the simplest case of a probability summation model whereby the probability of detection (discrimination) is given by the sum of probabilities of detection by independent mechanisms. In the city block metric model, the absolute values of the differences in the neural signals are summed and this sum is taken as a measure for the discriminability of two stimuli.

Polygonal models have been used to find stage 2 mechanisms. Sperling & Harwerth (1971) fitted a dominance metric model to monkey and human spectral sensitivities. Later Nuboer & Moed (1983) used a similar approach to make inferences about post-receptor mechanisms from spectral sensitivity in the rabbit (*Oryctolagus cuniculus*). Backhaus (1991) fitted a city block metric model to honeybee colour discrimination (Section V.2c; Fig. 5).

Polygonal models of colour thresholds have more parameters than ellipsoid models. Therefore, before invoking a polygonal model, it is desirable to show that thresholds are significantly less well fitted by an ellipsoid (Figs 3B, 4C). In reality, given the scatter of experimental data, it is difficult to distinguish between ellipsoidal and polygonal models (Fig. 5). For example, ellipsoidal models fit the thresholds for both humans (Poirson & Wandell, 1990) and bees (Brandt & Vorobyev, 1997) almost as well as polygonal models (Fig. 5).

Brandt & Vorobyev (1997) tested a number of models on von Helversen's (1972) measurements of honeybee spectral sensitivity (Fig. 5). Models that

assume that receptor signals do not interact (Fig. 1B) fail to explain the data. This implies that receptor signals are integrated by some neural mechanism (Fig. 1, stage 2) before responses to different stimuli are compared (stage 3). Likewise, single-mechanism models – such as those described in Section V.2.c – do not fit the data. To explain honeybee spectral sensitivity one needs to assume at least two stage 2 mechanisms, which must be insensitive to intensity variation, and involve chromatic interactions between receptor signals.

(b) Receptor noise and colour thresholds

The best vision can do is to meet a limit set by the noise originating in the photoreceptors. Actual performance is worse than this limit because receptor signals are corrupted by noise originating more proximally in the visual pathway. One may expect receptor noise to set thresholds because phototransduction is metabolically costly (Laughlin, de Ruyter van Steveninck & Anderson, 1998), so that if it were not limiting selection would simply reduce expenditure on phototransduction. In this context, it is perhaps surprising that the predictions of classical line element models (Helmholtz, 1896) that invoke receptor limits to colour discrimination do not in fact fit experimental data (Figs 3B, 5A).

A new model of colour discrimination thresholds (Fig. 5A) suggesting a minor modification of the noise-limited models discussed so far (Vorobyev & Osorio, 1998; Appendix B) fits experimental data well. It takes account of the 'ecological' consideration that chromatic signals are more reliable than achromatic. We have mentioned that both bees and birds use chromatic signals for colour discrimination (Section IV). Accordingly, the model assumes that performance is limited by receptor noise, but also that colour is coded exclusively by opponent (chromatic) mechanisms that are insensitive to intensity differences. Noise in the opponent signals is set by (or equals) receptor noise. The only model parameters are the noise levels in the receptor signals, which can either be measured physiologically or estimated from the relative number of photoreceptor cells. Consequently, the model has no free parameters, and its predictions can be compared directly with behavioural data. It does indeed fit behavioural spectral sensitivities of birds, mammals and insects (Fig. 5; Vorobyev & Osorio, 1998). For the honeybee, the model predicts the absolute value of thresholds from noise measured by electrophysiology (Vorobyev *et al.*, 2001).

The applicability of this receptor-noise-limited colour opponent model indicates that its assumptions hold for a variety of animals. However, for vertebrates the model often fails to predict thresholds in dim light (above cone threshold), almost certainly because the achromatic signal is used (Vorobyev & Osorio, 1998).

(4) Threshold models as a tool to study the biological relevance of colour vision

The traditional use of threshold models is to test hypotheses about physiological mechanisms, although as we have seen (Fig. 5) different mechanisms can give quite similar predictions. A second use is to investigate the ecology, evolution and design of colour vision. For example, it is now easy to measure spectra of natural objects such as food plants or bird plumage. Given an accurate model of performance, one can compare the suitability of different types of eye for tasks such as discriminating among a set of spectra, or detecting them against the background. This is especially worthwhile if performance is limited by photoreceptor noise, because photoreceptor spectral sensitivities are known for many different animals (Table 1), and one can often make a reasonable estimate of their relative noise levels (Vorobyev & Osorio, 1998).

For example, recent studies have asked how well dichromatic and trichromatic eyes would serve a primate looking for fruit against a background of leaves (Osorio & Vorobyev, 1996; Sumner & Mollon, 2000). Pursuing this idea one can also model the performance of hypothetical eyes, where for example visual pigment spectral sensitivities are shifted, e.g. in birds without oil droplets (Vorobyev *et al.*, 1998). Finally, we can also ask how a specific light habitat could influence the evolution of receptor sensitivities (Chiao *et al.*, 2000).

VII. CONCLUSIONS

(1) Animals of all major phyla have multiple visual pigments and photoreceptor types.

(2) Most animals with multiple receptors use colour vision.

(3) Achromatic signals and chromatic signals probably yield different types of information in natural conditions, and may generally be represented by separate neural mechanisms. Chromatic

signals and colour vision are important for recovering object surface properties under variable illumination.

(4) A variety of methods can demonstrate colour vision without knowledge of underlying receptors or neural mechanisms.

(5) Knowledge of photoreceptor sensitivities permits the use of simple experimental methods to demonstrate colour vision, to determine the number of receptors involved and to investigate subsequent neural processing.

(6) Knowledge of photoreceptor sensitivities, behaviourally measured spectral sensitivities and models together build a powerful tool for studies of the ecology and evolution of colour vision.

VIII. ACKNOWLEDGEMENTS

We gratefully acknowledge Simon Laughlin's constructive comments on an earlier version of the manuscript, they helped to make the paper readable! Thanks to Tom Cronin, to Justin Marshall and to everybody in the Lund Vision Group for inspiring and helpful discussions! This work was supported by a grant from the Swedish Research Council to A. K. and by N. S. F. grant no. IBN 9724028 to T. W. Cronin and NIH grant no. ROI EY0669 to J. Troy.

IX. APPENDIX A: COLOUR SPACES

Graphical representation of colour is useful for describing experimental data and for modelling colour thresholds. (Such representations do not predict thresholds.) Since colour can be defined by the set of n receptor quantum catches it can be represented as a point in the n -dimensional colour space (Fig. 2). For trichromatic vision, colour can be presented as a point (Q) in the three-dimensional receptor space, where quantum catches of the long-wavelength (Q_L), middle-wavelength (Q_M) and short-wavelength (Q_S) are placed along the co-ordinate axes. Where receptor sensitivities are known quantum catches can be easily calculated for any light stimulus (equation 1). Generally, it is convenient to use a co-ordinate system (q_i), where quantum catches for stimuli are divided by those for a reference stimulus or the background, Q_i^0 , to give a receptor contrast space (Cole, Hine & McIlhagga, 1993):

$$q_i = \frac{Q_i}{Q_i^0}. \quad (\text{A1})$$

If the reference corresponds to a background of a colour stimulus, equation A1 is a model of chromatic adaptation. It is the simplest algorithm of correction for changes of illumination (colour constancy), allowing independent rescaling of receptor signals, (von Kries, 1905), and is used widely to model colour constancy (Hurlbert, 1998; Dörr & Neumeyer, 2000). This is because for an eye viewing a reflecting surface, quantum catches change with changes of illumination but the rescaled receptor signal (equation A1) changes substantially less.

Instead of the receptor space, ‘chromaticity’ diagrams are often useful (Fig. 2; Wyszecki & Stiles, 1982). In these diagrams, the intensity or achromatic dimension is removed so that the location of a light stimulus does not depend on its intensity, consequently they have one dimension less than the corresponding colour space. Chromaticity diagrams were introduced because humans perceive chromatic aspects of colour (hue and saturation) to be substantially independent of intensity. Nonetheless, chromaticity diagrams reduce the information about colour, and are useful only for animals with separate chromatic and achromatic signals. For trichromatic eyes a common two-dimensional representation is to plot the unit plane, $Q_S + Q_M + Q_L = 1$, of the receptor space (Figs 2B, 4A). A line connecting the origin with the point \mathbf{Q} or its extension must intersect the unit plane at a point \mathbf{q}^c , whose receptor co-ordinates are given by:

$$q_i^c = \frac{Q_i}{Q_S + Q_M + Q_L}, \quad (\text{A2})$$

where $i = S, M, L$. This intersection gives a stereographic projection of the point \mathbf{Q} onto the unit plane. The location of that point determines the chromaticity of the colour, whereas the length of the vector characterizes its luminosity or brightness. This chromaticity diagram is an equilateral triangle, and is called the Maxwell triangle after its inventor. To plot a point in the plane of a Maxwell triangle it is convenient to use Cartesian axes:

$$X_1 = \frac{1}{\sqrt{2}}(q_L^c - q_M^c), \quad (\text{A3})$$

$$X_2 = \frac{\sqrt{2}}{\sqrt{3}} \left(q_S^c - \frac{(q_L^c + q_M^c)}{2} \right). \quad (\text{A4})$$

Note that these axes are not related to opponent mechanisms. The vertices of the triangle have the following co-ordinates:

$$\begin{aligned} \text{S: } & \left(0, \frac{\sqrt{2}}{\sqrt{3}} \right); \\ \text{M: } & \left(-\frac{1}{\sqrt{2}}, -\frac{\sqrt{2}}{2\sqrt{3}} \right); \\ \text{L: } & \left(\frac{1}{\sqrt{2}}, -\frac{\sqrt{2}}{2\sqrt{3}} \right). \end{aligned} \quad (\text{A5})$$

Maxwell’s triangle is the most commonly used diagram used in studies of trichromatic animals. However, in physiologically oriented studies it may be convenient to use axes corresponding to opponency mechanisms. For humans and trichromatic primates the luminance mechanism is driven by the summed M and L cone signals; the ‘yellow–blue’ opponency mechanism compares signals of S cones with signals of both L and M cones, and the ‘red–green’ mechanism compares L and M signals. The existence of separate pathways corresponding to these three mechanisms is established by psychophysical and physiological studies of trichromatic primates (Jameson & Hurvich, 1955; Krauskopf *et al.*, 1982; Dacey, 2000). Unfortunately, for other species the directions of opponency mechanisms are unknown. MacLeod & Boynton (1979) proposed a two-dimensional diagram, with axes corresponding to ‘red–green’ and ‘yellow–blue’ mechanisms:

$$(L - M)/(L + M) = (Q_L - Q_M)/(Q_M + Q_L), \quad (\text{A6})$$

$$S/(L + M) = Q_S/(Q_M + Q_L). \quad (\text{A7})$$

Note that the position of a point on this diagram is normalized similarly to that of the Maxwell triangle, and is thus independent of light intensity. A modification of this diagram uses log-transformed axes (Regan *et al.*, 1998).

For tetrachromatic vision (Fig. 2C) colour spaces are four-dimensional, and corresponding chromaticity diagrams three-dimensional. Generalisation of the Maxwell triangle gives a tetrahedron (e.g. Goldsmith, 1991). A three-dimensional stereographic projection onto unit three-dimensional space, $Q_{VS} + Q_S + Q_M + Q_L = 1$ is given by:

$$q_i^c = \frac{Q_i}{Q_{VS} + Q_S + Q_M + Q_L}, \quad (\text{A8})$$

where $i = VS, S, M, L$. To plot points in the three-dimensional space, it is convenient to use the following co-ordinates:

$$X_1 = \frac{1}{\sqrt{2}}(q_L^c - q_M^c), \quad (\text{A9})$$

$$X_2 = \frac{\sqrt{2}}{\sqrt{3}} \left(q_S^c - \frac{(q_L^c + q_M^c)}{2} \right), \quad (\text{A10})$$

$$X_3 = \frac{\sqrt{3}}{2} \left(q_{VS}^c - \frac{(q_L^c + q_M^c + q_S^c)}{3} \right). \quad (\text{A11})$$

The X_i and q_i^c co-ordinates are related by transformation of rotation. The vertices of this colour tetrahedron are located at:

$$\begin{aligned} \text{VS: } & \left(0, 0, \frac{\sqrt{3}}{2} \right); \text{ S: } \left(0, \frac{\sqrt{2}}{\sqrt{3}}, -\frac{1}{2\sqrt{3}} \right); \\ \text{M: } & \left(-\frac{1}{\sqrt{2}}, -\frac{\sqrt{2}}{2\sqrt{3}}, -\frac{1}{2\sqrt{3}} \right); \\ \text{L: } & \left(\frac{1}{\sqrt{2}}, -\frac{\sqrt{2}}{2\sqrt{3}}, -\frac{1}{2\sqrt{3}} \right). \end{aligned} \quad (\text{A12})$$

Commercial software can plot three-dimensional co-ordinates (Fig. 2C).

X. APPENDIX B. RECEPTOR-NOISE-LIMITED COLOUR OPPONENT MODEL

The model (Vorobyev & Osorio, 1998) is based on three assumptions: (i) For a visual system with n receptor channels colour is coded by $n - 1$ unspecified opponent mechanisms, the achromatic signal is disregarded. (ii) Opponent mechanisms give zero signal for stimuli that differ from background only in intensity. (iii) Thresholds are set by receptor noise, and not by opponent mechanisms.

The model has the following mathematical formulation. Let f_i be the signal of receptor mechanism i , Δf_i the difference in receptor signals between two stimuli, and Δx_α the difference in colour opponent mechanism, α . Generally, Δx_α is given by a linear combination of the differences of receptor signals, i.e.

$$\Delta x_\alpha = \sum_{i=1}^n F_{\alpha i} \Delta f_i \quad (\text{B1})$$

where the coefficient $F_{\alpha i}$ describes the input of receptor i to opponent mechanism α . If opponent signals only are used for discrimination, then the distance between stimuli, ΔS , is given by a function of the noise and differences in opponent signals, Δx_α . Assuming that receptor noise is dominant, stimulus discriminability does not depend on how receptor signals combine to form opponent signals. Consequently, the expression for the distance between stimuli depends only on Δf_i and the standard

deviation of the noise in the receptor mechanism, e_i , and need not contain $F_{\alpha i}$. For stimuli close to an achromatic background, if assumptions *i-iii* hold, colour distance is given by the following equations (Vorobyev & Osorio, 1998):

$$(\Delta S)^2 = \frac{(\Delta f_L - \Delta f_S)^2}{(e_S)^2 + (e_L)^2}, \quad (\text{B2})$$

$$\begin{aligned} (\Delta S)^2 = & \frac{e_S^2 (\Delta f_L - \Delta f_M)^2 + e_M^2 (\Delta f_L - \Delta f_S)^2 + e_L^2 (\Delta f_S - \Delta f_M)^2}{(e_S e_M)^2 + (e_S e_L)^2 + (e_M e_L)^2}, \end{aligned} \quad (\text{B3})$$

$$\begin{aligned} (\Delta S)^2 = & ((e_S e_{VS})^2 (\Delta f_L - \Delta f_M)^2 \\ & + (e_M e_{VS})^2 (\Delta f_L - \Delta f_S)^2 \\ & + (e_S e_M)^2 (\Delta f_L - \Delta f_{VS})^2 \\ & + (e_S e_{VS})^2 (\Delta f_M - \Delta f_S)^2 \\ & + (e_L e_S)^2 (\Delta f_M - \Delta f_{VS})^2 \\ & + (e_L e_M)^2 (\Delta f_S - \Delta f_{VS})^2) \\ & / ((e_S e_M e_L)^2 + (e_{VS} e_S e_L)^2 \\ & + (e_{VS} e_S e_M)^2), \end{aligned} \quad (\text{B4})$$

for di-, tri- and tetra-chromatic vision, respectively. Receptor signals are functions of the receptor quantum catches, and two simple models relating the receptor signals to quantum catches can be considered: (i) a linear relationship (Vorobyev & Osorio, 1998); (ii) a log-linear relationship (Vorobyev *et al.*, 1998, 2001). Because results of the model calculations do not depend on the units in which receptor signals are measured, receptor signals can be re-scaled so that they are related to quantum catches, q_i (equation A1) by $f_i = q_i$ or $f_i = \ln(q_i)$ for the linear or log-linear models respectively. Note that for stimuli which are close to a reference, both models make the same predictions. For the log-linear model, noise in the receptor mechanism, e_i , equals the Weber fraction of the corresponding mechanism, ω_i (Vorobyev *et al.*, 2001).

If receptor signals are linearly related to quantum catches, modeled chromatic signals remain insensitive to stimulus intensity only in the vicinity of the achromatic point. A logarithmic transformation makes chromatic processing insensitive to changes of stimulus intensity throughout colour space. Consequently, this logarithmic version of the model gives a chromaticity diagram, where colour loci are independent of the stimulus intensity, and Euclidean distance corresponds to the distance given by equations B2–B4. For trichromatic vision the

following axes can be used to plot colour loci (Hempel de Ibarra, Giurfa & Vorobyev, 2001):

$$\begin{aligned} X_1 &= A(f_L - f_M), \\ X_2 &= B(f_S - (af_L + bf_M)), \end{aligned} \quad (\text{B5})$$

where:

$$\begin{aligned} A &= \sqrt{\frac{1}{(\omega_M)^2 + (\omega_L)^2}}, \\ B &= \sqrt{\frac{(\omega_M)^2 + (\omega_L)^2}{(\omega_S \omega_M)^2 + (\omega_S \omega_L)^2 + (\omega_M \omega_L)^2}}, \\ a &= \frac{(\omega_M)^2}{(\omega_M)^2 + (\omega_L)^2}, \\ b &= \frac{(\omega_L)^2}{(\omega_M)^2 + (\omega_L)^2}, \end{aligned} \quad (\text{B6})$$

$f_i = \ln(q_i)$, and ω_i is the Weber fraction of mechanism i . Then the distance in the colour space given by equation B3 can be expressed as

$$\Delta S^2 = \Delta X_1^2 + \Delta X_2^2, \quad (\text{B7})$$

where X_1 and X_2 are given by equation B5.

XI. REFERENCES

- AHNELT, P. K. & KOLB, H. (2000). The mammalian photoreceptor mosaic – adaptive design. *Progress in Retinal and Eye Research* **19**, 711–777.
- AIDLEY, D. J. (1998). *The Physiology of Excitable Cells*. 4th edn. Cambridge University Press.
- ANONYMUS (1889). Review of ‘On the senses, instincts and intelligence of animals’ by J. Lubbock. *New Englander and Yale Review* **50**, 373–374.
- ARIKAWA, K., INOKUMA, K. & EGUCHI, E. (1987). Pentachromatic visual system in a butterfly. *Naturwissenschaften* **74**, 297–298.
- ARIKAWA, K., MIZUNO, S., SCHOLTEN, D. G. W., KINOSHITA, M., SEKI, T., KITAMOTO, J. & STAVENGA, D. G. (1999). An ultraviolet absorbing pigment causes a narrow-band violet receptor and a single-peaked green receptor in the eye of the butterfly *Papilio*. *Vision Research* **39**, 1–8.
- ARNOLD, K. & NEUMEYER, C. (1987). Wavelength discrimination in the turtle *Pseudemys scripta elegans*. *Vision Research* **27**, 1501–1511.
- ASENJO, A. B., RIM, J. & OPRIAN, D. D. (1994). Molecular determinants of human red/green color discrimination. *Neuron* **12**, 1131–1138.
- AUTRUM, H. & THOMAS, I. (1973). Comparative physiology of colour vision. In *Handbook of Sensory Physiology, vol VII/3A, Central Processing of Visual Information A: Integrative Functions and Comparative Data* (ed. R. Jung), pp. 631–692. Springer, Berlin.
- AUTRUM, H. & VON ZWEHL, V. (1964). Die spektrale Empfindlichkeit einzelner Sehzellen des Bienenauges. *Zeitschrift für vergleichende Physiologie* **48**, 357–384.
- BACKHAUS, W. (1991). Color opponent coding in the visual-system of the honeybee. *Vision Research* **31**, 1381–1397.
- BACKHAUS, W. K. G., KLIEGL, R. & WERNER, J. S. (1998). *Color Vision. Perspectives from Different Disciplines*. Gruyter, Berlin, New York.
- BARLOW, H. B. (1982). What causes trichromacy? A theoretical analysis using comb-filtered spectra. *Vision Research* **22**, 635–643.
- BAYLOR, D. A. & HODGKIN, A. L. (1973). Detection and resolution of visual stimuli by turtle photoreceptors. *Journal of Physiology* **234**, 163–198.
- BEAUCHAMP, R. D. & ROWE, J. S. (1977). Goldfish spectral sensitivity: a conditioning heart rate measure in restrained or curarized fish. *Vision Research* **17**, 617–624.
- BEIER, W. & MENZEL, R. (1972). Untersuchungen über den Farbensinn der deutschen Wespe (*Paravespula germanica* F., Hymenoptera, Vespidae): Verhaltensphysiologischer Nachweis des Farbsehens. *Zoologische Jahrbücher. Abteilung für allgemeine Zoologie und Physiologie der Tiere* **76**, 441–454.
- BLEST, A. D., HARDIE, R. C., MCINTYRE, P. & WILLIAMS, D. S. (1981). The spectral sensitivities of identified receptors and the function of retinal tiering in the principal of a jumping spider. *Journal of Comparative Physiology* **145**, 227–239.
- BONAVENTURE, N. (1961). La vision des couleurs chez le chat. *Psychologie Française* **6**, 1–10.
- BOWMAKER, J. K. (1995). The visual pigments of fish. *Progress in Retinal and Eye Research* **15**, 1–31.
- BOWMAKER, J. K. (1998). Evolution of colour vision in vertebrates. *Eye* **12**, 541–547.
- BOWMAKER, J. K. & DARTNALL, H. J. (1980). Visual pigments of rods and cones in a human retina. *Journal of Physiology* **298**, 501–511.
- BOWMAKER, J. K., HEATH, L. A., WILKIE, S. E. & HUNT, D. M. (1997). Visual pigments and oil droplets from six classes of photoreceptor in the retinas of birds. *Vision Research* **37**, 2183–2194.
- BOWMAKER, J. K. & HUNT, D. M. (1999). Molecular biology of photoreceptor spectral sensitivity. In *Adaptive Mechanisms in the Ecology of Vision* (eds. S. N. Archer et al.), pp. 439–462. Kluwer, Dordrecht.
- BOWMAKER, J. K., THORPE, A. & DOUGLAS, R. H. (1991). Ultraviolet-sensitive cones in the goldfish. *Vision Research* **31**, 349–352.
- BRANDT, R. & VOROBYEV, M. (1997). Metric analysis of threshold spectral sensitivity in the honeybee. *Vision Research* **37**, 425–437.
- BRISCOE, A. & CHITTKA, L. (2001). Insect color vision. *Annual Review of Entomology* **46**, 471–510.
- BUCHHOLTZ, C. (1952). Untersuchungen über das Farbsehen der Hauskatze (*Felis domestica* L.). *Zeitschrift für Tierpsychologie* **9**, 462–470.
- BURKAMP, W. (1923). Versuche über das Farbenwiedererkennen der Fische. *Zeitschrift für Sinnesphysiologie* **55**, 133–170.
- BUSCH, H. & DÜCKER, G. (1987). Das visuelle Leistungsvermögen der Seebären (*Arctocephalus pusillus* und *Arctocephalus australis*). *Zoologischer Anzeiger* **219**, 197–224.
- BYRNE, A. & HILBERT, D. R. (1997). *The Science of Colour*, Vol. 2. MIT Press, Cambridge.
- CHIAO, C. C., VOROBYEV, M., CRONIN, T. W. & OSORIO, D. (2000). Spectral tuning of dichromats to natural scenes. *Vision Research* **40**, 3257–3271.
- CHITTKA, L., BEIER, W., HERTEL, H., STEINMANN, E. & MENZEL,

- R. (1992). Opponent colour coding is a universal strategy to evaluate the photoreceptor inputs in hymenoptera. *Journal of Comparative Physiology A* **170**, 545–563.
- COGAN, A. I. (1995). Vision comes to mind. *Perception* **24**, 811–826.
- COHEN, A. I. (1972). Rods and cones. In *Handbook of Sensory Physiology, vol. VII/2, Physiology of Photoreceptor Organs* (ed. M. G. F. Fuortes), pp. 63–110. Springer, Berlin.
- COLE, G. R., HINE, T. & McILHAGGA, W. (1993). Detection mechanisms in L-, M-, and S-cone contrast space. *Journal of the Optical Society of America A* **10**, 138–151.
- COLLIN, S. P., POTTER, I. C. & BRAEKEVELT, C. R. (1999). The ocular morphology of the southern hemisphere lamprey *Geotria australis* Gray with special reference to optical specialisations and the characterisation and phylogeny of photoreceptor types. *Brain Behavior and Evolution* **54**, 96–118.
- CRANE, J. (1955). Imaginal behavior of a Trinidad butterfly, *Heliconius erato hydra* Hewitson, with special reference to the social use of color. *Zoologica (N.Y.)* **40**, 167–196.
- CRESCITELLI, F. & POLLACK, J. D. (1972). Dichromacy in the antelope ground squirrel. *Vision Research* **12**, 1553–1586.
- CROCKER, R., RINGO, J., WOLBRASHT, M. L. & WAGNER, H. G. (1980). Cone contributions to cat retinal ganglion cell receptive fields. *J. Gen. Physiol.* **76**, 763–765.
- CRONIN, T. W. & MARSHALL, N. J. (1989). Multiple spectral classes of photoreceptors in the retinas of gonodactylid stomatopod shrimps. *Journal of Comparative Physiology A* **166**, 261–275.
- DACEY, D. M. (2000). Parallel pathways for spectral coding in primate retina. *Annual Review of Neuroscience* **23**, 743–775.
- DARTNALL, H. J. A. (1953). The interpretation of spectral sensitivity curves. *British Medical Bulletin* **9**, 24–30.
- DAUMER, K. (1956). Reizmetrische Untersuchung des Farbsehens der Bienen. *Zeitschrift für vergleichende Physiologie* **38**, 413–478.
- DERIM-OGU, E. N. & MAXIMOV, V. V. (1994). Small passerines can discriminate ultraviolet surface colours. *Vision Research* **34**, 1535–1539.
- DERIM-OGU, E. N., PAVLOVA, I. Y. & MAXIMOV, V. V. (1987). Color-vision in pied flycatcher (*Muscicapa hypoleuca*). *Zoologicheskij Zhurnal* **66**, 1354–1362.
- DEVALOIS, R. L. & DEVALOIS, K. D. (1997). Neural coding of color. In *Readings on Color vol. 2* (eds. A. Byrne and D. R. Hilbert), pp. 93–140. MIT, Cambridge.
- DIMENTMAN, A. M., KONDRASHEV, S. L. & ORLOV, O. Y. (1978). A study of the mechanism of colour constancy in grey toad (*Bufo bufo* L.). In *Mechanisms of Vision in Animals*. Mosqva, pp. 85–95 (in Russian).
- DIMMOCK, R. V. JR & DAVIDS, C. (1985). Spectral sensitivity and photo-behaviour of the water mite genus *Unionicola*. *Journal of Experimental Biology* **119**, 349–363.
- DÖRR, S. & NEUMEYER, C. (2000). Color constancy in goldfish: the limits. *Journal of Comparative Physiology A* **186**, 885–896.
- DOUGLAS, R. H. & MARSHALL, N. J. (1999). A review of vertebrate and invertebrate optical filters. In *Adaptive Mechanisms in the Ecology of Vision* (eds. S. N. Archer et al.), pp. 95–162. Kluwer, Dordrecht.
- DÜCKER, G. (1957). Farb- und Helligkeitssehen und Instinkte bei Viveriiden und Feliden. *Zoologische Beiträge Neue Folge* **3**, 25–100.
- EISFELDT, D. (1967). Untersuchungen über das Farbsehvermögen einiger Wildcaniden. *Zeitschrift für wissenschaftliche Zoologie* **174**, 177–225.
- EMMERTON, J. & DELIUS, J. D. (1980). Wavelength discrimination in the visible and ultraviolet spectrum by pigeons. *Journal of Comparative Physiology* **141**, 47–52.
- FALZMAN, I. A. & BASTAKOV, V. A. (1999). Display of prey color preferences by green toad *Bufo viridis* Laur. after satiation. *Journal of General Biology* **60**, 199–206.
- FASICK, J. I., CRONIN, T. W., HUNT, D. M. & ROBINSON, P. R. (1998). The visual pigments of the bottlenose dolphin (*Tursiops truncatus*). *Visual Neuroscience* **15**, 643–651.
- FERENS, B. (1947). On the ability of colour-discrimination of the tawny owl (*Strix aluco aluco* L.). *Bulletin International de l'Académie Polonaise des Sciences et des Lettres (Series B, II)* **1947**, 300–337.
- FIRSOV, M. L., GOVARDOVSKII, V. I. & DONNER, K. (1994). Response univariance in bull-frog rods with two visual pigments. *Vision Research* **34**, 839–847.
- FLEISHMAN, L. J. & PERSONS, M. (2001). The influence of color and motion on signal visibility in *Anolis* lizards. *Journal of Experimental Biology* **204**, 1559–1575.
- FRIEDMAN, H. (1967). Color vision in the Virginia opossum. *Nature* **213**, 835–836.
- FRI SCH, K. v. (1912). Über farbige Anpassung bei Fischen. *Zoologische Jahrbücher. Abteilung für allgemeine Zoologie und Physiologie der Tiere* **32**, 209–214.
- FRI SCH, K. v. (1913a). Über die Farbanpassung des Crenilabrus. *Zoologische Jahrbücher. Abteilung für allgemeine Zoologie und Physiologie der Tiere* **33**, 151–164.
- FRI SCH, K. v. (1913b). Weitere Untersuchungen über den Farbensinn der Fische. *Zoologische Jahrbücher. Abteilung für allgemeine Zoologie und Physiologie der Tiere* **34**, 43–68.
- FRI SCH, K. v. (1914). Der Farbensinn und Formensinn der Biene. *Zoologische Jahrbücher. Abteilung für allgemeine Zoologie und Physiologie der Tiere* **35**, 1–188.
- FRI SCH, K. v. & KUPPELWIESER, H. (1913). Über den Einfluß der Lichtfarbe auf die phototaktischen Reaktionen niederer Krebs. *Biologisches Zentralblatt* **33**, 517–552.
- FUKUSHI, T. (1990). Colour discrimination from various shades of grey in the trained blowfly *Lucilia cuprina*. *Journal of Comparative Physiology A* **166**, 57–64.
- GNYUBKIN, V. D., KONDRASHEV, S. L. & ORLOV, O. Y. (1975). Constancy of colour perception in the grey toad. *Biofizika* **20**, 725–730.
- GOLDSMITH, T. H. (1991). The evolution of visual pigments and colour vision. In *The Perception of Colour* (ed. P. Gouras), pp. 62–89. MaxMillan, London.
- GOLDSMITH, T. H., COLLINS, J. C. & PERLMAN, D. L. (1981). A wavelength discrimination function for the hummingbird *Archilochus alexandri*. *Journal of Comparative Physiology* **143**, 103–110.
- GOVARDOVSKII, V. I., BYZOV, A. L., ZUEVA, L. V., POLISCZUK, N. A. & BABURINA, E. A. (1991). Spectral characteristics of photoreceptors and horizontal cells in the retina of the Siberian sturgeon *Acipenser baeri* Brandt. *Vision Research* **31**, 2047–2056.
- GOVARDOVSKII, V. I., FYHRQUIST, N., REUTER, T., KUZMIN, D. G. & DONNER, K. (2000). In search of the visual pigment template. *Visual Neuroscience* **17**, 509–528.
- GOVARDOVSKII, V. I. & LYCHAKOV, D. V. (1984). Visual cells and visual pigments of the lamprey, *Lampetra fluviatilis*. *Journal of Comparative Physiology A* **154**, 279–286.
- GOVARDOVSKII, V. I. & ZUEVA, L. V. (1974). Spectral sensitivity of the frog eye in the ultraviolet and visible region. *Vision Research* **14**, 1317–1321.

- GRIEBEL, U. & SCHMID, A. (1992). Color vision in the Californian sea lion (*Zalophus californicus*). *Vision Research* **36**, 2747–2757.
- GRIEBEL, U. & SCHMID, A. (1996). Color vision in the manatee (*Trichechus manatus*). *Vision Research* **32**, 477–482.
- GRZIMEK, B. (1952). Versuche über das Farbsehen von Pflanzensessern. I. Das farbige Sehen (und die Schärfe) von Pferden. *Zeitschrift für Tierpsychologie* **9**, 23–39.
- HAILMAN, J. P. & JAEGER, R. G. (1974). Phototactic responses to spectrally dominant stimuli and use of colour vision by adult anuran amphibians: a comparative study. *Animal Behaviour* **22**, 757–795.
- HARDIE, R. C. (1986). The photoreceptor array of the dipteran retina. *Trends in Neuroscience* **9**, 419–423.
- HARIYAMA, T., TSUKAHARA, Y. & MEYER-ROCHOW, V. B. (1993). Spectral responses, including a UV-sensitive cell type, in the eye of the isopod *Ligia exotica*. *Naturwissenschaften* **80**, 233–235.
- HART, N. S. (2001). Visual ecology of avian photoreceptors. *Progress in Retinal and Eye Research* **20**, 675–703.
- HATEREN, J. H. v. (1993). Spatial, temporal and spectral pre-processing for colour vision. *Proceedings of the Royal Society of London B* **251**, 61–68.
- HELMHOLTZ, H. v. (1896). *Handbuch der physiologischen Optik* (2nd edition). Voss, Hamburg.
- HELVENSEN, O. v. (1972). Zur spektralen Unterschiedsempfindlichkeit der Honigbiene. *Journal of Comparative Physiology* **80**, 439–472.
- HEMMI, J. (1999). Dichromatic colour vision in an Australian marsupial, the tammar wallaby. *Journal of Comparative Physiology A* **185**, 509–515.
- HEMMI, J. & GRÜNERT, U. (1999). Distribution of photoreceptor types in the retina of a marsupial, the tammar wallaby (*Macropus eugenii*). *Visual Neuroscience* **16**, 291–302.
- HEMPEL DE IBARRA, N., GIURFA, M. & VOROBYEV, M. (2001). Detection of coloured patterns by honeybees through chromatic and achromatic cues. *Journal of Comparative Physiology A* **187**, 215–224.
- HERING, E. (1878). *Zur Lehre vom Lichtsinne*. Carl Gerold's Sohn, Wien.
- HERTZ, M. (1928). Wahrnehmungspsychologische Untersuchungen am Eichelhäher. *Zeitschrift für vergleichende Physiologie* **7**, 144–195 and 616–657.
- HIMSTEDT, W. (1972). Untersuchungen zum Farbsehen von Urodelen. *Journal of Comparative Physiology* **81**, 229–238.
- HISATOMI, O., KAYADA, S., AOKI, Y., IWASA, T. & TOKUNAGA, F. (1994). Phylogenetic relationships among vertebrate visual pigments. *Vision Research* **34**, 3097–3102.
- HOFFMANN, G. (1952). Untersuchungen über das Farbsehvermögen des Zebu. *Zeitschrift für Tierpsychologie* **9**, 470–479.
- HURLBERT, A. C. (1998). Computational models of colour constancy. In *Perceptual Constancy: Why things look as they do* (eds V. Walsh and J. Kulikowski), pp. 283–322. Cambridge University Press.
- HYATT, G. W. (1975). Physiological and behavioural evidence for color discrimination by fiddler crabs (Brachyura, Ocypodidae, genus *Uca*). In *Physiological Ecology of Estuarine Organisms* (ed. F. J. Vernberg). University of South Carolina Press, Columbia.
- ILSE, D. (1928). Über den Farbensinn der Tagfalter. *Zeitschrift für vergleichende Physiologie* **8**, 658–692.
- ILSE, D. (1949). Colour discrimination in the dronefly, *Eristalis tenax*. *Nature* **163**, 255.
- ISHIHARA, S. (1917). *Tests for colour blindness* (First Edition). Tokyo, Kanehira Shuppan.
- JACOBS, G. H. (1976). Wavelength discrimination in grey squirrels. *Vision Research* **16**, 325–327.
- JACOBS, G. H. (1978). Spectral sensitivity and color vision in the ground-dwelling sciurids: results from golden-mantled ground squirrels and comparison of five species. *Animal Behaviour* **26**, 409–421.
- JACOBS, G. H. (1981). *Comparative Color Vision*. Academic Press, New York.
- JACOBS, G. H. (1993). The distribution and nature of colour vision among the mammals. *Biological Reviews* **68**, 413–471.
- JACOBS, G. H. & NEITZ, J. (1985). Color vision in squirrel monkeys: sex-related differences suggest the mode of inheritance. *Vision Research* **25**, 141–143.
- JACOBS, G. H. & NEITZ, J. (1986). Spectral mechanisms and color vision in the tree shrew (*Tupaia belangeri*). *Vision Research* **26**, 291–298.
- JAEGER, R. G. & HAILMAN, J. P. (1971). Two types of phototactic behaviour in Anuran amphibians. *Nature* **230**, 189–190.
- JAMESON, D. & HURVICH, L. M. (1955). Some quantitative aspects of opponent-colors theory. I. Chromatic responses and spectral saturation. *Journal of the Optical Society of America* **45**, 546–552.
- KASPERCZYK, M. (1971). Comparative studies on colour sense in amphibia (*Rana temporaria* L., *Salamandra salamandra* L. and *Triturus cristatus* Laur.). *Folia Biologica (Krakow)* **19**, 241–288.
- KAWAMURA, S. & YOKOYAMA, S. (1998). Functional characterization of visual and nonvisual pigments of American chameleon (*Anolis carolinensis*). *Vision Research* **38**, 37–44.
- KELBER, A. (1997). Innate preferences for flower features in the hawkmoth *Macroglossum stellatarum*. *Journal of Experimental Biology* **200**, 827–836.
- KELBER, A. (1999). Ovipositing butterflies use a red receptor to see green. *Journal of Experimental Biology* **202**, 2619–2630.
- KELBER, A. (2001). Receptor based models for spontaneous colour choices in flies and butterflies. *Entomologia Experimentalis et Applicata* **99**, 231–244.
- KELBER, A. & HÉNIQUE, U. (1999). Trichromatic colour vision in the hummingbird hawkmoth, *Macroglossum stellatarum* L. *Journal of Comparative Physiology A* **184**, 535–541.
- KELBER, A. & PFAFF, M. (1999). True colour vision in the Orchard butterfly, *Papilio aegaeus*. *Naturwissenschaften* **86**, 221–224.
- KEZELI, A. R., MAXIMOV, V. V., LOMASHVILI, N. J., KHOMERIKI, M. S. & TSHKVEDIANI, N. G. (1987). Participation of the green-sensitive cone mechanism of the cat retina in colour discrimination. *Sechenov Physiological Journal of the USSR* **73**, 883–889 (in Russian).
- KING-SMITH, P. E. (1969). Absorption spectra and function of the coloured oil drops in the pigeon retina. *Vision Research* **9**, 1391–1399.
- KINOSHITA, M., SHIMADA, N. & ARIKAWA, K. (1999). Colour vision in the foraging swallowtail butterfly *Papilio xuthus*. *Journal of Experimental Biology* **202**, 95–102.
- KITAMOTO, J., SAKAMOTO, K., OZAKI, K., MISHINA, Y. & ARIKAWA, K. (1998). Two visual pigments in a single photoreceptor cell: identification and histological localization of three mRNAs encoding visual pigment opsins in the retina of the butterfly *Papilio xuthus*. *Journal of Experimental Biology* **201**, 1255–1261.

- KNOLL, F. (1921). *Bombylius fuliginosus* und die Farbe der Blumen. *Abhandlungen der Zoologisch-Botanischen Gesellschaft in Wien* **12**, 17–119.
- KNOLL, F. (1922). Lichtsinn und Blumenbesuch des Falters von *Macroglossum stellatarum*. *Abhandlungen der Zoologisch-Botanischen Gesellschaft in Wien* **12**, 121–377.
- KNOLL, F. (1926). Lichtsinn und Blütenbesuch des Falters von *Deilephila livornica*. *Zeitschrift für vergleichende Physiologie* **2**, 328–380.
- KOEHLER, O. (1924). Über das Farbsehen von *Daphnia magna* Straus. *Zeitschrift für vergleichende Physiologie* **1**, 84–174.
- KOLLER, G. (1927). Über Chromatophorensystem, Farbensein und Farbwechsel bei *Crangon vulgaris*. *Zeitschrift für vergleichende Physiologie* **5**, 191–246.
- KOLLER, G. (1928). Versuche über den Farbensein der Eupaguriden. *Zeitschrift für vergleichende Physiologie* **8**, 337–353.
- KONDRASHEV, S. L., GNYUBKIN, V. F., DIMENTMAN, A. M. & ORLOV, O. Y. (1976). Role of visual stimuli in mating behavior of males in grass frog (*Rana temporaria*), grey toad (*Bufo bufo*) and green toad (*Bufo viridis*). *Zoological Journal USSR* **55**, 1027–1037 (in Russian).
- KONG, K.-L., FUNG, Y. M. & WASSERMAN, G. S. (1980). Filter-mediated color vision with one visual pigment. *Science* **207**, 783–786.
- KOSKELAINEN, A., HEMILA, S. & DONNER, K. (1994). Spectral sensitivities of short-wavelength and long-wavelength sensitive cone mechanisms in the frog retina. *Acta Physiologica Scandinavica* **152**, 115–124.
- KRAUSKOPF, J., WILLIAMS, D. R. & HEELEY, D. W. (1982). Cardinal directions of color space. *Vision Research* **22**, 1123–1131.
- KRIES, J. VON. (1905). Die Gesichtsempfindungen. In *Handbuch der Physiologie des Menschen*, Vol. 3 (ed. W. Nagel), pp. 109–282. Vieweg, Braunschweig.
- KRÖGER, R. H. H., BOWMAKER, J. K. & WAGNER, H. J. (1999). Morphological changes in the retina of *Aequidens pulcher* (Cichlidae) after rearing in monochromatic light. *Vision Research* **39**, 2441–2448.
- KUGLER, H. (1950). Der Blütenbesuch der Schlammfliege (*Eristalomyia tenax*). *Zeitschrift für vergleichende Physiologie* **32**, 328–347.
- KÜHN, A. (1927). Über den Farbensein der Bienen. *Zeitschrift für vergleichende Physiologie* **5**, 762–800.
- LAUGHLIN, S. B., DE RUYTER VAN STEVENINCK, R. R. & ANDERSON, J. C. (1998). The metabolic cost of neural information. *Nature Neuroscience* **1**, 36–41.
- LEHRER, M. (1993). Spatial vision in the honeybee: the use of different cues in different tasks. *Vision Research* **34**, 2363–2385.
- LIEBMAN, P. & ENTINE, G. (1968). Visual pigments of frog and tadpole (*Rana pipens*). *Vision Research* **8**, 761–775.
- LOEW, E. R. (1994). A third ultraviolet-sensitive visual pigment in the Tokay gecko. *Vision Research* **34**, 1427–1431.
- LOEW, E. R. & GOVARDOVSKII, V. I. (2002). *Visual Neuroscience* (in press).
- LOOP, M. S., MILLIGAN, C. L. & THOMAS, S. R. (1987). Photopic spectral sensitivity of the cat. *Journal of Physiology* **382**, 537–553.
- LOSEV, I. S. & MAXIMOV, V. V. (1982). An application of a pair comparison method to deriving the effectiveness of stimuli in behavioural experiments. In *Sensory systems. Vision*. Leningrad Nauka, pp. 126–138.
- LOTMAR, R. (1933). Neue Untersuchungen über den Farbensein der Bienen, mit besonderer Berücksichtigung des Ultravioletts. *Zeitschrift für vergleichende Physiologie* **19**, 673–723.
- LUBBOCK, J. (1888). *On the Senses, Instincts and Intelligence of Animals with Special Reference to Insects*. London, Kegan Paul.
- LUNAU, K. & WACHT, S. (1994). Optical releasers of the innate proboscis reflex in the hoverfly *Eristalis tenax* L. (Syrphidae, Diptera). *Journal of Comparative Physiology A* **174**, 575–579.
- MACLEOD, D. I. A. & BOYNTON, R. M. (1979). Chromaticity diagram showing cone excitation by stimuli of equal luminance. *Journal of the Optical Society of America* **69**, 1183–1186.
- MAIER, E. J. (1992). Spectral sensitivities including the ultraviolet of the passeriform bird *Leiothrix lutea*. *Journal of Comparative Physiology A* **170**, 709–714.
- MAIER, E. J. & BOWMAKER, J. K. (1993). Colour vision in the passeriform bird, *Leiothrix lutea*: Correlation of visual pigment absorbency and oil droplet transmission with spectral sensitivity. *Journal of Comparative Physiology A* **172**, 295–301.
- MALONEY, L. T. (1986). Evaluation of linear models of surface spectral reflectance with small numbers of parameters. *Journal of the Optical Society of America A* **3**, 1673–1683.
- MARSHALL, N. J., JONES, J. P. & CRONIN, T. W. (1996). Behavioural evidence for colour vision in stomatopod. *Journal of Comparative Physiology A* **179**, 473–481.
- MARSHALL, N. J. & MESSENGER, J. B. (1996). Colour blind camouflage. *Nature* **382**, 408–409.
- MARSHALL, N. J., KENT, J. & CRONIN, T. (1999). Visual adaptations in crustaceans: spectral sensitivity in diverse habitats. In *Adaptive Mechanisms in the Ecology of Vision* (eds S. N. Archer *et al.*), pp. 285–327. Kluwer, Dordrecht.
- MARSHALL, N. J. & OBERWINKLER, J. (1999). The colourful world of the mantis shrimp. *Nature* **401**, 873–874.
- MARTIN, G. R. (1974). Color vision in the tawny owl (*Strix aluco*). *Journal of Comparative and Physiological Psychology* **86**, 133–141.
- MATSUI, S., SEIDOU, M., UCHIYAMA, I., SEKIYA, N., HIRAKI, K., YOSHIHARA, K. & KITO, Y. (1988). 4-Hydroxyretinal, a new visual pigment chromophore found in the bioluminescent squid, *Watasenia scintillans*. *Biochimica et Biophysica Acta* **966**, 370–374.
- MAXIMOV, V. V. (2000). Environmental factors which may have led to the appearance of colour vision. *Philosophical Transactions of the Royal Society London B* **355**, 1239–1242.
- MAXWELL, J. C. (1860). On the theory of compound colours and the relations of the colours of the spectrum. *Philosophical Transactions of the Royal Society London B* **150**, 57–84.
- MAZOKHIN-PORSHNYAKOV, G. A. (1969). *Insect Vision*. Plenum, New York.
- MCENROE, W. D. & DRONKA, K. (1966). Color vision in the adult female two-spotted spider mite. *Science* **154**, 782–784.
- MEINERTZHAGEN, I. A., MENZEL, R. & KAHLE, G. (1983). The identification of spectral receptor types in the retina and lamina of the dragonfly *Sympetrum rubicundulum*. *Journal of Comparative Physiology A* **151**, 295–310.
- MELLO, N. K. & PETERSON, N. J. (1964). Behavioral evidence for color vision in cat. *Journal of Neurophysiology* **27**, 323–333.
- MENG, M. (1958). Untersuchungen zum Farben- und Formsehen der Erdkröte (*Bufo bufo* L.). *Zoologische Beiträge Neue Folge* **3**, 313–364.
- MENZEL, R. (1979). Spectral sensitivity and color vision in invertebrates. In *Handbook of Sensory Physiology, vol VII/6A, Vision in Invertebrates* (ed. H. Autrum), pp. 503–580. Springer, Berlin.

- MENZEL, R. & BACKHAUS, W. (1991). Colour vision in insects. In *The Perception of Colour* (ed. P. Gouras), pp. 262–293. MaxMillan, London.
- MENZEL, R. & BLAKERS, M. (1976). Colour receptors in the bee eye – morphology and spectral sensitivity. *Journal of Comparative Physiology* **108**, 11–33.
- MESSENGER, J. B. (1981). Comparative physiology of vision in molluscs. In *Handbook of Sensory Physiology, vol. VII, 6c* (ed. H. Autrum), pp. 93–200. Springer, Berlin.
- MEYER-OEHME, D. (1957). Dressurversuche an Eichhörnchen zur Frage ihres Helligkeits- und Farbensehens. *Zeitschrift für Tierpsychologie* **14**, 472–509.
- MEYKNECHT, J. (1941). Farbsehen und Helligkeitsunterscheidung beim Steinkauz (*Athene noctua vidalii* A. E. Brehm). *Ardea* **30**, 129–170.
- MOERICKE, V. (1950). Über das Farbsehen der Pfirsichblattlaus (*Myzodes persicae* Sulz.). *Zeitschrift für Tierpsychologie* **7**, 265–274.
- MOLLON, J. D. (1989). ‘Tho’ she kneel’d in that place where they grew ...’ The uses and origins of primate colour vision. *Journal of Experimental Biology* **146**, 21–38.
- MOLLON, J. D. (1997). ‘... aus dreyerley Arten von Membranen oder Molekülen’: George Palmer’s legacy. In *Colour Vision Deficiencies XIII*, 1997 (ed. C. R. Cavonius), pp. 1–18. Kluwer, Dordrecht.
- MOLLON, J. D. & ESTÉVEZ, O. (1988). Tyndall’s paradox of hue discrimination. *Journal of the Optical Society of America A* **5**, 151–159.
- MOTE, M. I. & GOLDSMITH, T. H. (1970). Spectral sensitivities of color receptors in the compound eye of the cockroach *Periplaneta*. *Journal of Experimental Zoology* **173**, 137–145.
- MUNTZ, W. R. A. (1962). Effectiveness of different colors of light in releasing positive phototactic behavior of frogs, and a possible function of the retinal projection to the diencephalon. *Journal of Neurophysiology* **25**, 712–720.
- MUNTZ, W. R. A. (1963). Phototaxis and green rods in urodeles. *Nature* **199**, 620.
- NAKAMURA, T. & YAMASHITA, S. (2000). Learning and discrimination of colored papers in jumping spiders (Araneae, Salticidae). *Journal of Comparative Physiology A* **186**, 897–901.
- NATHANS, J. (1999). The evolution and physiology of human color vision: insights from molecular genetic studies of visual pigments. *Neuron* **24**, 299–312.
- NEITZ, M. & NEITZ, J. (2001). The uncommon retina of the common house mouse. *Trends in Neuroscience* **24**, 248–250.
- NEITZ, J., GEIST, T. & JACOBS, G. H. (1989). Color vision in the dog. *Visual Neuroscience* **2**, 97–100.
- NEUMEYER, C. (1984). On spectral sensitivity in the goldfish. Evidence for neural interactions between different ‘cone mechanisms’. *Vision Research* **24**, 1223–1231.
- NEUMEYER, C. (1985). An ultraviolet receptor as a fourth receptor type in goldfish. *Naturwissenschaften* **72**, 162–163.
- NEUMEYER, C. (1986). Wavelength discrimination in the goldfish. *Journal of Comparative Physiology A* **158**, 203–213.
- NEUMEYER, C. (1991). Evolution of colour vision. In *Vision and Visual Dysfunction*, Vol. 2 (ed. J. Cronly-Dillon), pp. 284–305. Macmillan, Houndsmills.
- NEUMEYER, C. (1992). Tetrachromatic colour vision in goldfish: evidence from color mixture experiments. *Journal of Comparative Physiology A* **171**, 639–649.
- NEUMEYER, C. (1998). Comparative colour constancy. In *Perceptual Constancy: Why things look as they do* (eds. V. Walsh and J. Kulikowski), pp. 323–351. Cambridge University Press.
- NEUMEYER, C. & ARNOLD, K. (1989). Tetrachromatic color vision in the goldfish becomes trichromatic under white adaptation light of moderate intensity. *Vision Research* **29**, 1719–1727.
- NEUMEYER, C. & JÄGER, J. (1985). Spectral sensitivity of the freshwater turtle *Pseudemys scripta elegans*: evidence for the filter effect of colored oil droplets. *Vision Research* **25**, 833–838.
- NOSAKI, H. (1969). Electrophysiological study of color encoding in the compound eye of crayfish, *Procambarus clarkii*. *Zeitschrift für vergleichende Physiologie* **64**, 318–323.
- NUBOER, J. F. W. & MOED, P. J. (1983). Increment-threshold spectral sensitivity in the rabbit experiments. *Journal of Comparative Physiology A* **151**, 353–358.
- ORBELI, L. A. (1909). On the question of differentiation of colours by dogs. *Physiological department of Institute of Experimental Medicine, St. Petersburg*.
- ORLOV, Y. M. & MAXIMOV, V. V. (1982). Color vision and behaviour of amphibians. In *Sensory Systems. Vision*, pp. 114–125. Leningrad Nauka.
- OSORIO, D., MIKLÓSI, A. & GONDA, Z. (1999a). Visual ecology and perception of coloration patterns by domestic chicks. *Evolutionary Ecology* **13**, 673–689.
- OSORIO, D., RUDERMAN, D. L. & CRONIN, T. W. (1998). Estimation of errors in luminance signals encoded by primate retina resulting from sampling of natural images with red and green cones. *Journal of the Optical Society of America A* **15**, 16–22.
- OSORIO, D. & VOROBYEV, M. (1996). Colour vision as an adaptation to frugivory in primates. *Proceedings of the Royal Society London B* **263**, 593–599.
- OSORIO, D., VOROBYEV, M. & JONES, C. D. (1999b). Colour vision in domestic chicks. *Journal of Experimental Biology* **202**, 2951–2959.
- PALACIOS, A., MARTINOYA, C., BLOCH, S. & VARELA, F. J. (1990). Color mixing in the pigeon – a psychophysical determination in the longwave spectral range. *Vision Research* **30**, 587–596.
- PALACIOS, A. G. & VARELA, F. J. (1992). Color mixing in the pigeon (*Columba livia*). 2. A psychophysical determination in the middle, short and near-UV wavelength range. *Vision Research* **32**, 1947–1953.
- PALACIOS, A. G., VARELA, F. J., SRIVASTAVA, R. & GOLDSMITH, T. H. (1998). Spectral sensitivity of cones in the goldfish, *Carassius auratus*. *Vision Research* **38**, 2135–2146.
- PARTRIDGE, J. C. (1989). The visual ecology of avian cone oil droplets. *Journal of Comparative Physiology A* **165**, 415–426.
- PARTRIDGE, J. C. & CUMMINGS, M. E. (1999). Adaptation of visual pigments to the aquatic environment. In *Adaptive Mechanisms in the Ecology of Vision* (eds. S. N. Archer *et al.*), pp. 285–327. Kluwer, Dordrecht.
- PEICHL, L., BEHRMANN, G. & KRÖGER, R. H. H. (2001). For whales and seals the ocean is not blue: a visual pigment loss in marine mammals. *European Journal of Neuroscience* **13**, 1520–1528.
- PEITSCH, D., FIETZ, A., HERTEL, H., SOUZA, J. D., FIX VENTURA, D. & MENZEL, R. (1992). The spectral input systems of hymenopteran insects and their receptor-based colour vision. *Journal of Comparative Physiology A* **170**, 23–40.
- PERRY, R. J. & MCNAUGHTON, P. A. (1991). Response properties of cones from the retina of the tiger salamander. *Journal of Physiology* **433**, 561–587.

- PIRENNE, M. H. (1962). Spectral luminous efficiency of radiation. In *The Eye* (ed. H. Davson), pp. 65–91. Academic Press, London.
- PLATH, M. (1935). Über das Farbunterscheidungsvermögen des Wellensittichs. *Zeitschrift für vergleichende Physiologie* **22**, 691–708.
- POIRSON, A. B. & WANDELL, B. A. (1990). The ellipsoidal representation of spectral sensitivity. *Vision Research* **30**, 647–652.
- POLSON, M. C. (1968). Spectral sensitivity and color vision in *Tupaia glis*. Doctoral dissertation, Bloomington, Indiana: Indiana University.
- POWERS, M. K. & EASTER, S. S. JR (1978a). Absolute visual sensitivity of the goldfish. *Vision Research* **18**, 1137–1147.
- POWERS, M. K. & EASTER, S. S. JR (1978b). Wavelength discrimination by the goldfish near absolute visual threshold. *Vision Research* **18**, 1149–1154.
- PROKOPY, R. J., ECONOMOPOULOS, A. P. & MCFADDEN, M. W. (1975). Attraction of wild and laboratory-cultured *Dacus oleae* flies to small rectangles of different hues, saturation, and tints. *Entomologia Experimentalis et Applicata* **18**, 141–152.
- PROVENCIO, I., LOEW, E. R. & FOSTER, R. G. (1992). Vitamin A2-based visual pigments in fully terrestrial vertebrates. *Vision Research* **32**, 2201–2208.
- PRZYREMBEL, C., KELLER, B. & NEUMEYER, C. (1995). Trichromatic color vision in the salamander (*Salamandra salamandra*). *Journal of Comparative Physiology A* **176**, 575–586.
- QUARANTA, J. V. (1952). An experimental study of the color vision of the giant tortoise. *Zoologica (N.Y.)* **37**, 295–312.
- REGAN, B. C., FREUDENTHALER, N., KOLLE, R., MOLLON, J. D. & PAULUS, W. (1998). Colour discrimination thresholds in Parkinson's disease: results obtained with a rapid computer-controlled colour vision test. *Vision Research* **38**, 3427–3431.
- REMY, M. & EMMERTON, J. (1989). Behavioural spectral sensitivities of different retinal areas in pigeons. *Behavioral Neuroscience* **103**, 170–177.
- RINGO, J., WOLBRASHT, M. L., WAGNER, H. G., CROCKER, R. & AMTHOR, E. (1977). Trichromatic vision in the cat. *Science* **198**, 427–429.
- RÖHLICH, P., VEEN, T. VAN & SZEL, A. (1994). Two different visual pigments in one retinal cone cell. *Neuron* **13**, 1159–1166.
- ROSENGREN, A. (1969). Studies on colour vision in dogs. *Acta Zoologica Fennica* **121**, 3–19.
- RUBIN, J. M. & RICHARDS, W. A. (1982). Color vision and image intensities: when are changes material? *Biological Cybernetics* **45**, 215–226.
- RUSHTON, W. A. (1965). Visual adaptation. *Proceedings of the Royal Society (London) B* **162**, 22–46.
- SCHAERER, S. & NEUMEYER, C. (1996). Motion detection in goldfish investigated with the optomotor response is 'color blind'. *Vision Research* **36**, 4025–4034.
- SCHERER, C. & KOLB, G. (1987). Behavioural experiments on the visual processing of color stimuli in *Pieris brassicae* L. (Lepidoptera). *Journal of Comparative Physiology A* **160**, 645–656.
- SCHIEMENZ, F. (1923). Über den Farbensinn der Fische. *Zeitschrift für vergleichende Physiologie* **1**, 175–220.
- SCHLIEPER, K. (1927). Farbensinn der Tiere und optomotorische Reaktionen. *Zeitschrift für vergleichende Physiologie* **6**, 453–472.
- SCHNAPF, J. L., KRAFT, T. W. & BAYLOR, D. A. (1987). Spectral sensitivity of human cone photoreceptors. *Nature* **325**, 439–441.
- SCHREMMER, F. (1941a). Sinnesphysiologie und Blumenbesuch des Falters von *Plusia gamma* L. *Zoologische Jahrbücher, Abteilung für Systematik, Ökologie und Geographie der Tiere* **74**, 361–522.
- SCHREMMER, F. (1941b). Versuche zum Nachweis der Rotblindheit von *Vespa rufa*. *Zeitschrift für vergleichende Physiologie* **28**, 457–466.
- SECHZER, J. A. & BROWN, J. L. (1964). Color discrimination in the cat. *Science* **144**, 427–429.
- SHAFIR, S. (1996). Color discrimination of a wasp, *Polybia occidentalis* (Hymenoptera: Vespidae). *Biotropica* **28**, 243–251.
- SILLMAN, A. J., RONAN, S. J. & LOEW, E. R. (1991). Histology and microspectrophotometry of the photoreceptors of a crocodilian, *Alligator mississippiensis*. *Proceedings of the Royal Society (London) B* **243**, 93–98.
- SMITH, K. C. & MACAGNO, E. R. (1990). UV-photoreceptors in the compound eye of *Daphnia magna* (Crustacea, Branchiopoda): a forth spectral class in single ommatidia. *Journal of Comparative Physiology A* **166**, 597–606.
- SMITH, V. C. & POKORNY, J. (1975). Spectral sensitivity of the foveal cone photopigments between 400 and 500 nm. *Vision Research* **15**, 161–171.
- SNYDER, A. W., MENZEL, R. & LAUGHLIN, S. B. (1973). Structure and function of the fused rhabdom. *Journal of Comparative Physiology* **87**, 99–135.
- SPERLING, H. G. & HARWERTH, R. S. (1971). Red-green cone interactions in the increment-threshold spectral sensitivity of primates. *Science* **172**, 180–184.
- STOERIG, P. (1998). Wavelength information processing versus colour perception: evidence from blindsight and colour-blind sight. In *Color Vision. Perspectives from Different Disciplines* (eds W. K. G. Backhaus, R. Kliegl and J. S. Werner). Gruyter, Berlin, New York.
- STORZ, U. C. & PAUL, R. J. (1998). Phototaxis in water fleas (*Daphnia magna*) is differently influenced by visible and UV light. *Journal of Comparative Physiology A* **183**, 709–717.
- SÜFFERT, F. & GÖTZ, B. (1936). Verhalten von Schmetterlingsraupen gegenüber farbigen Flächen. *Naturwissenschaften* **51**, 815.
- SUMMERS, K., SYMULA, R., CLOUGH, M. & CRONIN, T. (1999). Visual mate choice in poison frogs. *Proceedings of the Royal Society of London B* **266**, 2141–2145.
- SUMNER, P. & MOLLON, J. D. (2000). Catarrhine photopigments are optimized for detecting targets against a foliage background. *Journal of Experimental Biology* **203**, 1963–1986.
- SWIHART, C. A. (1971). Colour discrimination by the butterfly, *Heliconius charitonius* Linn. *Animal Behaviour* **19**, 156–164.
- TROJE, N. (1993). Spectral categories in the learning behaviour of blowflies. *Zeitschrift für Naturforschung* **48c**, 96–104.
- VARELA, F. J., PALACIOS, A. G. & GOLDSMITH, T. H. (1993). Color vision in birds. In *Vision, Brain and Behavior in Birds* (ed. Ziegler), pp. 77–98. MIT Press, Cambridge MA.
- VOGT, K. (1989). Distribution of insect visual chromophores: functional and phylogenetic aspects. In *Facets of Vision* (eds D. G. Stavenga and R. C. Hardie), pp. 134–151. Springer, Berlin.
- VOGT, K. & KIRSCHFELD, K. (1984). Chemical identity of the chromophores of fly visual pigment. *Naturwissenschaften* **71**, 211–213.
- VOROBYEV, M., BRANDT, R., PEITSCH, D., LAUGHLIN, S. & MENZEL, R. (2001). Colour thresholds and receptor noise: behaviour and physiology compared. *Vision Research* **41**, 639–653.

- VOROBYEV, M. & MENZEL, R. (1999). Flower advertisement for insects: bees, a case study. In *Adaptive Mechanisms in the Ecology of Vision* (eds. S. N. Archer *et al.*), pp. 537–553. Kluwer, Dordrecht.
- VOROBYEV, M. & OSORIO, D. (1998). Receptor noise as a determinant of colour thresholds. *Proceedings of the Royal Society of London B* **265**, 351–358.
- VOROBYEV, M., OSORIO, D., BENNETT, A. T., MARSHALL, N. J. & CUTHILL, I. C. (1998). Tetrachromacy, oil droplets and bird plumage colours. *Journal of Comparative Physiology A* **183**, 621–633.
- WAGNER, H. (1932). Über den Farbensinn der Eidechsen. *Zeitschrift für vergleichende Physiologie* **18**, 378–392.
- WALD, G. (1939). The porphyropsin visual system. *Journal of General Physiology* **22**, 775–794.
- WALLA, P., BARTH, F. G. & EGUCHI, E. (1996). Spectral sensitivity of single photoreceptors in the eyes of the Ctenid spider *Cupiennius salei*. *Zoological Science* **13**, 199–202.
- WALLS, G. L. (1942). *The Vertebrate Eye and its Adaptive Radiation*. The Cranbrook Press, Bloomfield Hills.
- WALTON, W. E. & BORNEMEIER, R. W. (1938). Color discrimination in rats. *Journal of Comparative Psychology* **28**, 417–436.
- WARRANT, E. J. & NILSSON, D.-E. (1998). Absorption of white light in photoreceptors. *Vision Research* **38**, 195–207.
- WEHNER, R. & TOGGWEILER, F. (1972). Verhaltensphysiologischer Nachweis des Farbensehens bei *Cataglyphis bicolor* (Formicidae, Hymenoptera). *Journal of Comparative Physiology* **77**, 239–255.
- WILKENS, L. A. (1984). Ultraviolet sensitivity in hyperpolarizing photoreceptors of the giant clam *Tridacna*. *Nature* **309**, 446–448.
- WOJTUSIAK, R. J. (1932). Über den Farbensinn der Schildkröten. *Zeitschrift für vergleichende Physiologie* **18**, 393–436.
- WOLFF, H. (1925). Das Farbunterscheidungsvermögen der Ellritze. *Zeitschrift für vergleichende Physiologie* **2**, 279–329.
- WYSZECKI, G. & STILES, W. S. (1982). *Color Science: Concepts and Methods, Quantitative Data and Formulae*, 2nd Edn. Wiley, New York.
- YAMASHITA, S. & TATEDA, H. (1976). Spectral sensitivities of jumping spider eyes. *Journal of Comparative Physiology* **105**, 29–41.