



LUND UNIVERSITY

Low complexity channel estimation for LTE in fast fading environments for implementation on multi-standard platforms

Foroughi, Farzad; Karimdady Sharifabad, Farnaz; Edfors, Ove

Published in:

IEEE 72ND VEHICULAR TECHNOLOGY CONFERENCE FALL 2010

DOI:

[10.1109/VETECONF.2010.5594166](https://doi.org/10.1109/VETECONF.2010.5594166)

2010

[Link to publication](#)

Citation for published version (APA):

Foroughi, F., Karimdady Sharifabad, F., & Edfors, O. (2010). Low complexity channel estimation for LTE in fast fading environments for implementation on multi-standard platforms. In *IEEE 72ND VEHICULAR TECHNOLOGY CONFERENCE FALL 2010* IEEE - Institute of Electrical and Electronics Engineers Inc.. <https://doi.org/10.1109/VETECONF.2010.5594166>

Total number of authors:

3

General rights

Unless other specific re-use rights are stated the following general rights apply:

Copyright and moral rights for the publications made accessible in the public portal are retained by the authors and/or other copyright owners and it is a condition of accessing publications that users recognise and abide by the legal requirements associated with these rights.

- Users may download and print one copy of any publication from the public portal for the purpose of private study or research.
- You may not further distribute the material or use it for any profit-making activity or commercial gain
- You may freely distribute the URL identifying the publication in the public portal

Read more about Creative commons licenses: <https://creativecommons.org/licenses/>

Take down policy

If you believe that this document breaches copyright please contact us providing details, and we will remove access to the work immediately and investigate your claim.

LUND UNIVERSITY

PO Box 117
221 00 Lund
+46 46-222 00 00

Low complexity channel estimation for LTE in fast fading environments for implementation on multi-standard platforms

Farzad Foroughi Abari, Farnaz Karimdady Sharifabad , Ove Edfors
Dept. of Electrical and Information Technology, Box 118, Lund University, Sweden
Email: {Farzad.Foroughi@eit.lth.se, fkarimdady@gmail.com, Ove.Edfors@eit.lth.se}

Abstract—In this paper a number of low-complexity channel estimator structures tailored to the needs of LTE terminals have been investigated. The focus has been on the algorithms exhibiting reduced complexity while providing an acceptable level of performance. To design these estimators other factors such as interoperability with another OFDM-based standard, DVB-H, in a multi-standard environment have been taken into account. The key underlying parameter has been exploiting the pilot pattern in LTE providing the possibility of minimal filtering in time domain while exhibiting an acceptable level of performance in fast fading environments.

I. INTRODUCTION

Providing a multiple-access scheme, Orthogonal Frequency Division Multiplexing (OFDM) has replaced many of the traditional single carrier alternatives where data is encapsulated in symbols which are usually shorter than the time span of the physical channel. As a result, the communication over single carrier systems is usually prone to Inter Symbol Interference (ISI) and needs complicated equalization structures to reliably retrieve and decode the data on the receiver side.

In an OFDM based systems, however, data is modulated on a number of subcarriers which occupy a predefined BandWidth (BW). The system is designed in such a way that subcarrier spacing is chosen to be smaller than the coherence BW of the channel. As a result, simple equalization techniques can be carried out on the receiver side. The system, however, can suffer from Inter Carrier Interference (ICI) which results from the fast fading channel environments. To counter this problem, the symbol time in OFDM systems is designed to be shorter than the coherence time of the physical channel. Contrary to single carrier systems, parallel data multiplexing in the downlink for a number of User Equipments (UE) is rather simple in OFDM. The original idea of OFDM dates back to 1966 [1] but implementing the system was cumbersome due to technology shortcomings. The advances in digital signal processing and circuit design, however, have enabled practical realization of OFDM systems in recent years.

Initially, OFDM systems were used in combination with Single-Input-Single-Output systems (SISO) such as Digital Audio Broadcast (DAB). With the introduction of Multiple-Input-Multiple-Output (MIMO), opening a new horizon in the area of digital communications, new standards benefiting from the combination of both OFDM and MIMO emerged into the telecommunications world. The application of multiple antennas on both transmitter and receiver enables the system to enjoy various diversity, multiplexing and beam forming schemes.

Long Term Evolution (LTE) has been opted as the 4th generation standard for mobile wireless communications. LTE combines both OFDM and MIMO in downlink to materialize the desired data rates of up to 100 Mbits/Sec in fading environments. Channel estimation in LTE is complex but nonetheless important. To enable proper channel estimation, scattered pilots have been employed in the LTE downlink channel.

Channel estimation based on scattered pilots is considered a challenging task when limited processing power restricts the scope

of the applied algorithms. The estimator usually needs to interpolate the unknown subcarriers in two dimensions (time and frequency) which adds to the inherent complexity. The computational complexity becomes even more detrimental when the estimation needs to be carried out for a multitude of channels when the system is configured with MIMO.

This paper is a continuation of the work initiated in [2], where we derived and evaluated a new type of common estimator structure that can be used for both LTE and DVB-H in multi-standard terminals. A drawback with the approach chosen in [2] was that LTE could only be supported for speeds up to a few tens of km/h, while DVB-H could be supported well above 100 km/h. Here we concentrate on modifying the estimation strategy from [2] so that higher terminals speeds of up to 120 km/h, as specified by LTE, are also supported. The modifications, however, have been made at the expense of increased hardware complexity. Thus, in addition to a comparative analysis of the estimator performance, the hardware complexity of the proposed estimator has also been compared to some of the known estimators, e.g., the one in [2]. As stated above, the proposed estimator as such may be applied to both LTE and DVB-H standards in a multi-standard environment. However, the elaborate analysis of how this estimator could be applied to both LTE and DVB-H is beyond the scope of this paper¹.

II. LTE (LONG TERM EVOLUTION)

Mobile broadband encouraged the specification of LTE which became the basis for the next generation of UMTS Mobile standards [3]. One of the motivations behind LTE system design is to break the limitations of high data rates in wireless channels. The standardization not only demands LTE to provide high data rates in stationary channel environments but also demands that LTE based terminals provide a peak data rate of 100 Mbits/Sec in fading environments characterized with an equivalent terminal speed of up to 50 km/h while maintaining a moderate performance when the terminal speed increases up to 120km/h [4]. While many of the system components in LTE have already been standardized, some of the intermediate components, e.g., the channel estimator, have been left for the individual system designers and manufacturers to contemplate.

To assist channel estimation, pilot data known to both the transmitter and receiver are sent over the wireless channel. The pilots are either continual (e.g., in IEEE 802.11n) or scattered (e.g., LTE). Depending on the expected behavior of the wireless channel, one or a combination of both schemes will be employed for channel estimation purposes. LTE standardization has utilized scattered pilots in the downlink to assist the channel estimation. Fig. 1 illustrates how pilots have been scattered in time and frequency grid for a single antenna, i.e., antenna port 0. Considering the fact that channel

¹A detailed analysis of the possibility for interoperability between LTE and DVB-H by exploiting the similarities in their corresponding pilot patterns has been addressed in [2].

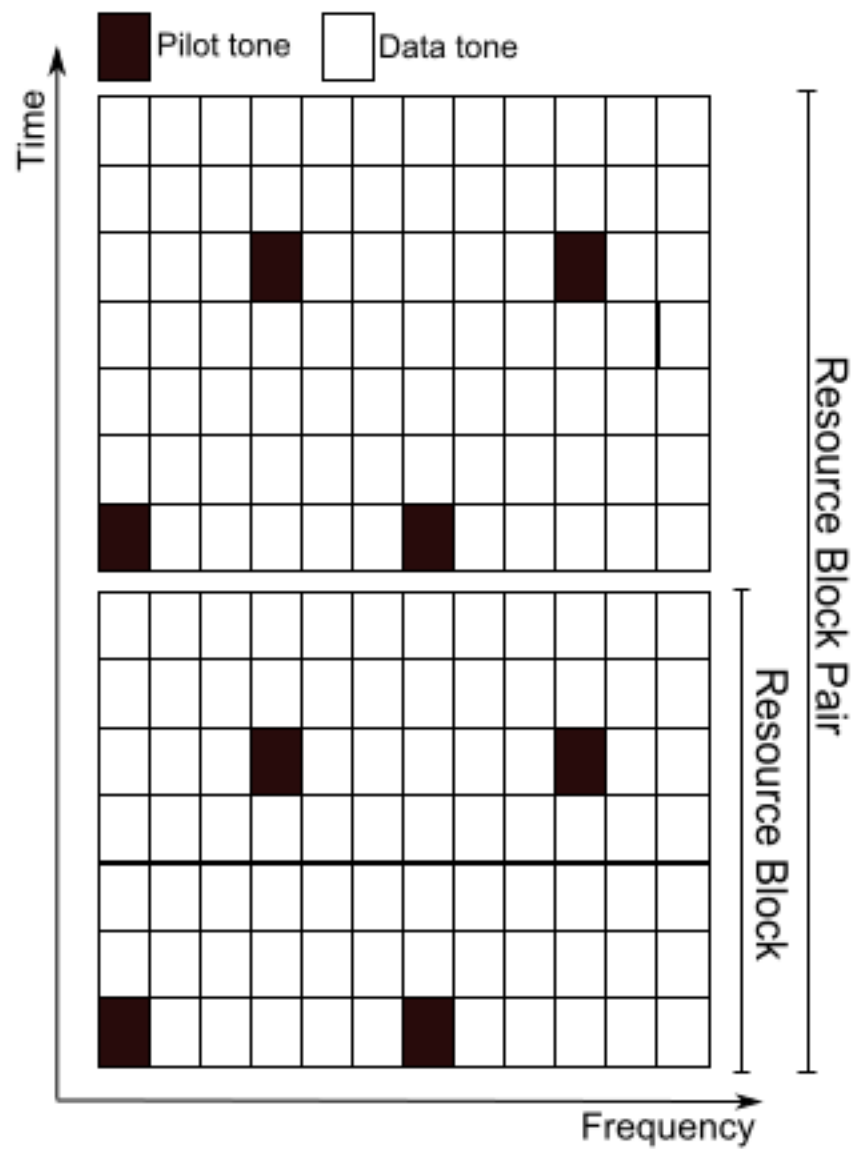

Fig. 1. LTE, scattered pilot structure. Each RBP consists of two consecutive RBs and covers 12 subcarriers over 14 OFDM symbols.

estimation for MIMO systems can be more cumbersome, as compared to SISO systems, LTE has defined different pilot patterns for the different antenna ports. To reduce the channel estimation complexity at the expense of spectral efficiency, the subcarriers corresponding to the pilot locations in one antenna port remain silent during data transmission on the other antenna ports. As a result, the estimator blocks don't need to take interference among the antenna ports into consideration when using pilot assisted channel estimation methods.

In contrast to some of the contemporary wireless communications systems such as DVB-H, data can be multiplexed for different users in each OFDM symbol in LTE. In other words, the BW of the system can be broken into a number of units each carrying data for one single UE. In LTE a Resource Block (RB) consists of twelve consecutive subcarriers in frequency and seven OFDM symbols in time as depicted in Fig. 1. Meanwhile, resource allocation for each UE consists of at least two consecutive RBs in time. Thus, the smallest allocable data unit to a typical UE is 12 subcarriers in 14 consecutive OFDM symbols known as one RB Pair (RBP). Fig. 1 shows how RB and RBP are defined over time-frequency grid in LTE. Having mentioned that, the UE needs to receive the first few OFDM symbols associated with the control region [5] in each RBP to decode the control signaling. Among other things, control signals carry information about data scheduling [5] for each UE. If no data has been allocated for a certain UE, it can enter a standby mode for the remaining OFDM symbols to save power.

The pilots associated with one RBP in LTE are distributed in OFDM symbols 1, 5, 8 and 12 for a 2×2 MIMO scheme. The pilot spacing in frequency domain for the pilot carrying OFDM symbols is 6 subcarriers. Fig. 1 displays an example of pilot structure for antenna port 0. The same pattern is shifted in frequency for antenna port 1. These pilots provide possibility of employing various channel estimation techniques, depending on the accuracy/complexity requirements of the system, to acquire the proper Channel State Information (CSI).

III. SYSTEM MODEL

Fig. 2 shows a simple MIMO OFDM system model which can be used as a reference for a simplified LTE system. For the purposes

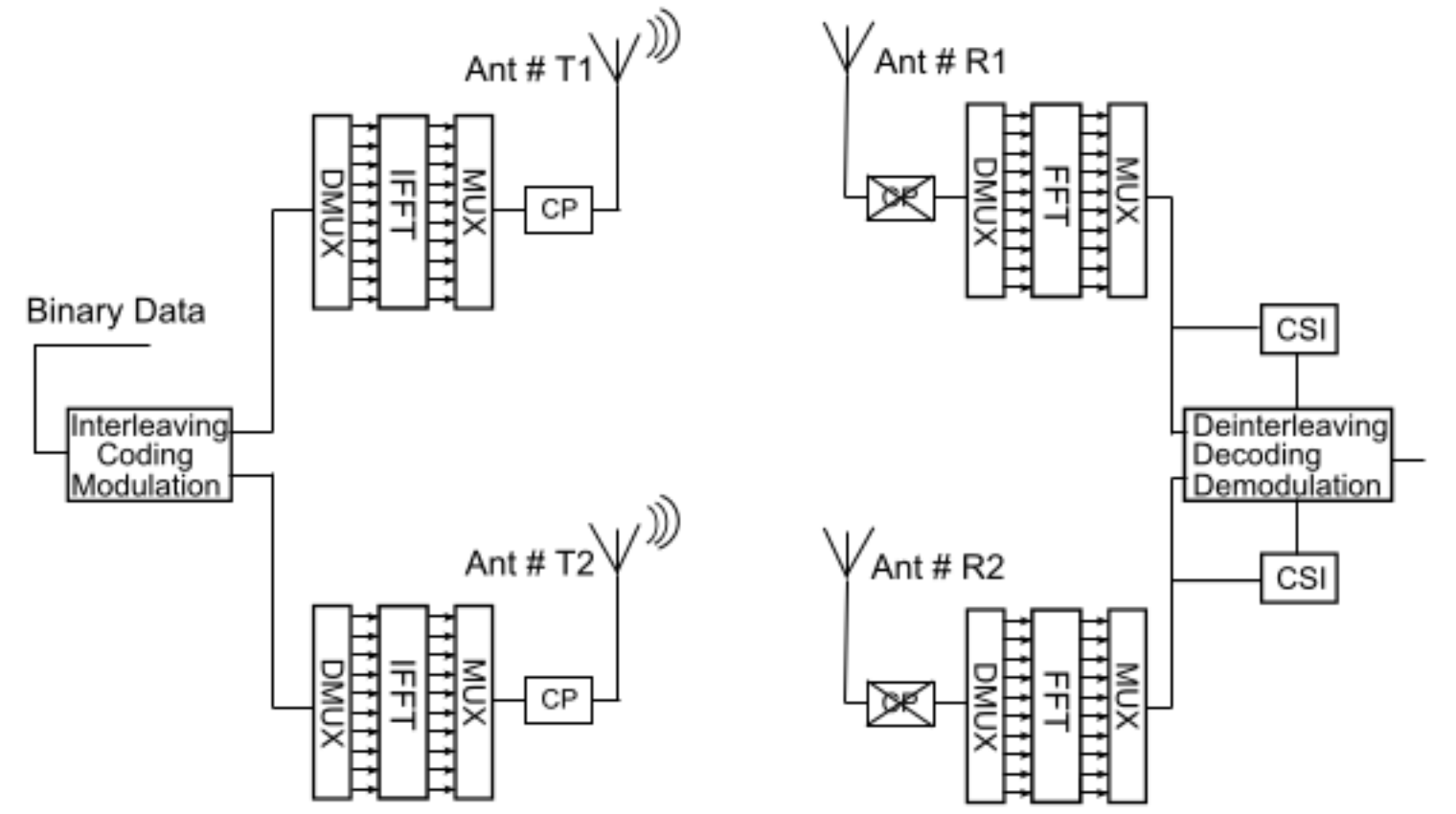

Fig. 2. LTE, simplified MIMO system model.

of simulation in this paper a 2×2 MIMO scheme with optional turbo coding, similar to the one standardized for LTE, has been used. LTE benefits from two different Cyclic Prefixes (CPs) known as normal and extended CPs [5] to prevent ISI. In this paper, we have resorted to the application of the normal CP. The same analysis can, of course, be done with the extended CP. This is, however, beyond the scope of this paper. Similar to a typical OFDM-based system, information is modulated through one of the standardized modulation schemes for LTE, e.g., 4QAM. The modulated data as well as the pilots are placed on the corresponding subcarriers and after zero padding, as standardized in LTE providing the necessary Guard Band (GB), the result is fed into an IFFT. The IFFT output is then CP extended, A/D converted and transmitted over a time dispersive wireless channel with AWGN. The wireless channel delay spread doesn't exceed the CP length. The received signal in the form of added multipath components is received on each receiving antenna and passed through a D/A. After CP removal, the result is OFDM demodulated through an FFT block. It is assumed that the channel doesn't vary during each OFDM symbol transmission and hence there is no ICI in the system. Besides, we have assumed perfect synchronization in the system.

For a 2×2 MIMO OFDM system, the narrowband MIMO system for each subcarrier k , can be described as

$$\begin{bmatrix} y_1(k) \\ y_2(k) \end{bmatrix} = \begin{bmatrix} h_{11}(k) & h_{12}(k) \\ h_{21}(k) & h_{22}(k) \end{bmatrix} \begin{bmatrix} x_1(k) \\ x_2(k) \end{bmatrix} + \begin{bmatrix} w_1(k) \\ w_2(k) \end{bmatrix} \quad (1)$$

, where $y_1(k)$ and $y_2(k)$ are the received signals on subcarrier k , $x_1(k)$ and $x_2(k)$ are the transmitted symbols on the k th subcarrier, $w_1(k)$ and $w_2(k)$ are the AWGN signals and each $h_{i,j}(k)$ in the channel matrix is the complex gain of the wireless channel between the j th transmit and the i th receive antenna on the k th subcarrier.

Furthermore, to describe the statistical properties of the wireless channel we can briefly resort to the time domain description where we have assumed that the wireless channels between each pair of transmit/receive antennas have the same properties and each can be mathematically described as [6]

$$h(t, \tau) = \sum_{l=0}^{L-1} \alpha_l(t) \delta(\tau - \tau_l). \quad (2)$$

The Channel Frequency Response (CFR) of the wireless channel at

time t can be written as

$$H(t, f) = \int_{-\infty}^{+\infty} h(t, \tau) \exp(-2j\pi\tau) d\tau. \quad (3)$$

Assuming Wide Sense Stationary (WSS) channel taps, the time-frequency correlation function of a channel can be described as

$$R(\Delta f, \Delta t) = E[H(f, t) \overline{H(f + \Delta f, t + \Delta t)}]. \quad (4)$$

It can be shown that the frequency correlation function, which is obtained by setting $\Delta t = 0$ in $R(\Delta f, \Delta t)$ is the Fourier transform of the Power Delay Profile (PDP) of the channel, while the time correlation function, which is obtained by setting $\Delta f = 0$ in $R(\Delta f, \Delta t)$ can be described by the inverse Fourier transform of the Doppler spectrum of the channel. The inverse Fourier transform of the Doppler spectrum for a two dimensional isotropic uncorrelated scattering environment is [7]

$$R(\Delta t) = J_0(2\pi\phi_{max}\Delta t), \quad (5)$$

where $J_0(\cdot)$ is the zeroth-order Bessel function of the first kind, ϕ_{max} is the maximum Doppler in Hertz and Δt is the time difference between two observations of the channel at two different time instances. During the rest of the paper, the equations and calculation will be carried out in frequency domain. Throughout the paper we have used bold lower case letters to represent vectors and bold upper case letters to represent matrices.

IV. CHANNEL ESTIMATION

The scattered pilot structure in LTE enables the application of various channel estimation techniques. The proper choice of the estimators depends on many factors among which the quality and the complexity of the estimators are the dominant criteria. Meanwhile, a lot of research has been done in the area of channel estimation for the wireless systems employing scattered pilots [6]. In one work [2], a number of DFT based estimators have been analyzed when applied to both LTE and DVB-H for a multi-standard terminal. The best linear estimator in terms of Mean Square Error (MSE) is the well-known 2-D LMMSE which exploits the second order channel statistics in time and frequency to estimate/interpolate the unknown subcarriers. However, real time processing of such a 2-D filter is intensive and due to its inherent complexity it is rarely used in practical systems. Meanwhile, it has been shown that the 2-D filter, under certain conditions, can be broken into two 1-D filters one in time and one in frequency with negligible performance loss [8]. The 1-D filter in frequency can be mathematically described as [9]

$$\hat{\mathbf{h}}_{m,se} = \mathbf{R}_{h_p h_p} (\mathbf{R}_{h_p h_p} + \frac{\beta}{SNR} \mathbf{I})^{-1} \hat{\mathbf{h}}_{p,ls}, \quad (6)$$

where $\mathbf{R}_{h_p h_p}$ is the autocorrelation of the sampled channel \mathbf{h}_p on pilot positions, $\mathbf{R}_{h_p h_p}$ is the cross correlation matrix between the pilot tones and the data subcarriers, $SNR = E|x_k|^2 / \sigma^2$ is the signal-to-noise ratio and β is a constant which depends on the signal constellation of transmitted pilot symbols. For a 4QAM modulation scheme β equals 1. Furthermore,

$$\hat{\mathbf{h}}_{p,ls} = \mathbf{X}_p^{-1} \mathbf{y}_p \quad (7)$$

is the Least Squares (LS) estimate of the channel attenuations \mathbf{h}_p on the pilot tones where \mathbf{X}_p is a matrix containing the transmitted pilot data on its diagonal and \mathbf{y}_p is the vector of received data symbols on the pilot tones.

According to (6), a matrix inversion of $N_p \times N_p$, where N_p is the number of available pilots, needs to be done each time the

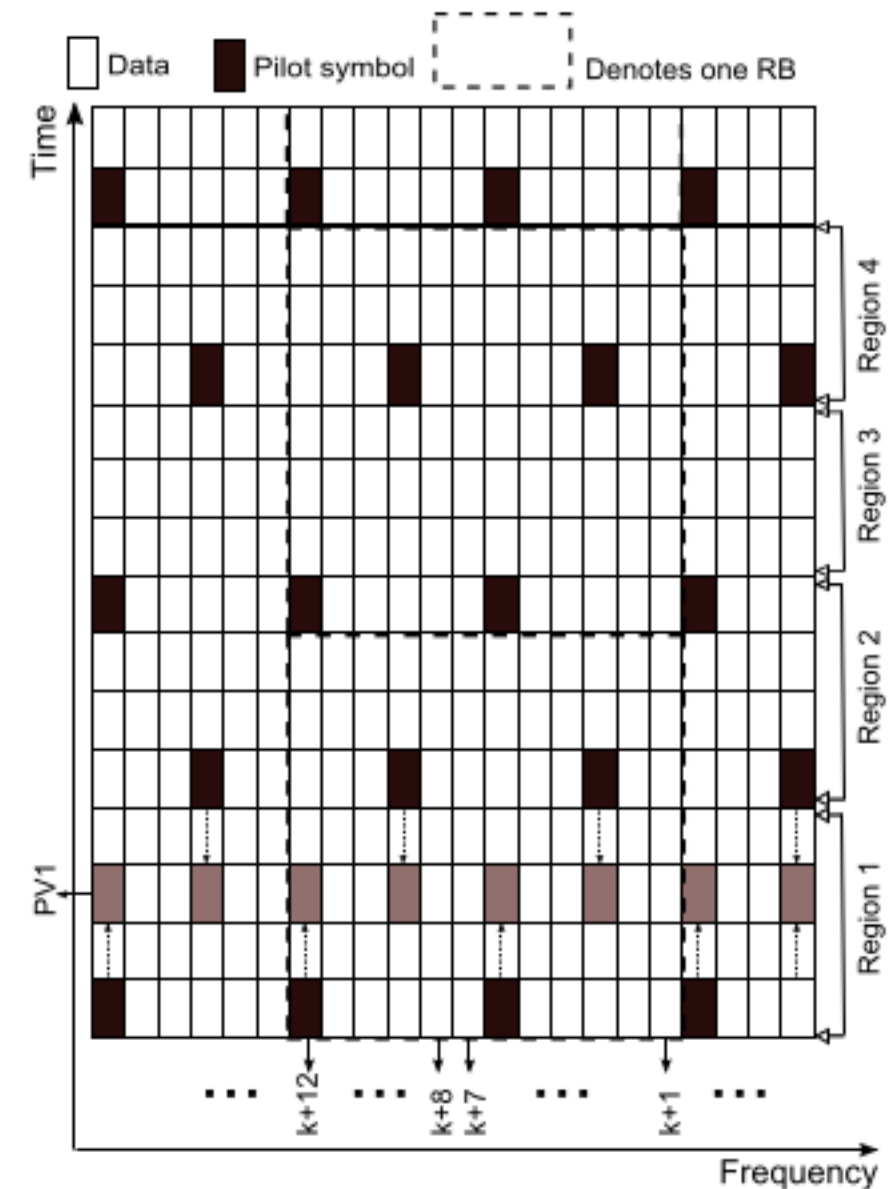

Fig. 3. Merged-pilot estimation technique, merging (collecting) the pilots into Pilot Vectors (PVs). This picture shows how pilots from the 1st and 5th OFDM symbols are collected to create PV1. For estimation of subcarriers in each region, the pilots from the two closest pilot carrying OFDM symbols are collected and fed into the M. R. MMSE estimator. Hence, four PVs are constructed and channel estimation is done four times per RBP each corresponding to one region for equalization purposes. The depicted PV in this figure consists of eight pilots chosen symmetrically with respect to subcarriers $k + 7$ and $k + 8$ and is used to estimate them in region 1. The proposed estimator in this paper, however, uses sixteen pilots instead.

second order channel statistics or the SNR value change. Thus, the complexity of the above estimator is still formidable. Due to the fact that the processing power on the mobile terminal is usually limited, a number of low complexity variants of the above estimator need to be derived. Reducing the complexity of the above estimator has been investigated in a number of previous works [6]. A simple method to overcome the matrix inversion problem, is to use a robust variant of the above estimator, robust MMSE [6], designed for a fixed SNR and a fixed PDP. Despite its performance loss, its reduced complexity makes this estimator more attractive for practical applications. In this paper, we have chosen a uniform design PDP where the worst case channel condition has been presumed. Although the robust MMSE estimator is more computationally efficient than the full MMSE, N_p complex multiplications need to be done to estimate each subcarrier in frequency. To counter the complexity problem even more, it has been shown [2] [10] that not all the available pilots in one OFDM symbol need to be used to estimate/interpolate each subcarrier. Acceptable performance can be achieved by only using the pilots in the vicinity of each subcarrier due to the correlation loss between subcarriers and pilots which are located far apart, especially in highly frequency selective channels. It has been shown [2] that for the LTE system configuration simulated in this paper, as few as 16 pilots will provide satisfactory performance in terms of BER. We call this estimator Modified Robust MMSE (M. R. MMSE) as originally proposed in [2].

Similarly, a robust MMSE in time direction can be used to estimate/interpolate the unknown subcarriers in time. The applied 1-D robust MMSE is designed based on the second order channel statistics in (5). Thus, the simplified 2-D MMSE (M. R. 2-D MMSE) can be performed through two separate 1-D filtering first in time

or frequency, followed by the filtering in the other domain [6]. In order to lower the complexity of the algorithm even further, we have adapted two more time domain strategies which waive the 1-D filtering in time. One approach is based on the well-known piecewise constant interpolation where the channel is estimated for each pilot carrying OFDM symbol in frequency and used for all the other subsequent non-pilot carrying symbols. As soon as the next pilot carrying symbol is received, a new frequency domain estimation is done and used likewise. The third method, merged-pilot², uses the mutual correlation existing between two consecutive pilot carrying OFDM symbols through merging (collecting) the pilots into a single Pilot Vector (PV) as depicted in Fig. 3. The constructed PV is then fed into a channel estimator and the corresponding CSI is estimated. The same CSI is used for equalization of all symbols exhibiting the shortest distance from the pilot contributing symbols. In other words, four CSIs corresponding to four PVs are obtained. CSI1 is used for equalization of OFDM symbols 1-4 (region 1), CSI2 is used for OFDM symbols 5-8 (region 2), CSI3 is used for OFDM symbols 9-11 (region 3) and CSI4 is used for OFDM symbols 11-14 (region 4). To achieve optimal results for region 4, the pilots from the first OFDM symbol corresponding to the next consecutive RBP are used to construct PV4 which is a valid assumption because the terminal always needs to listen to the first few OFDM symbols of each RBP to decode control signaling.

The above three approaches are characterized by their own pros and cons. The M. R. 2-D MMSE provides the best performance, especially in high Doppler scenarios. Yet, it has a larger computational complexity and causes a delay in the equalization and decoding since all the pilot symbols in the entire RBP are used for the estimation. The piecewise constant approach doesn't need much memory to store symbols before the estimation initiates. Hence, it doesn't cause any considerable delay in the system. Besides, the complexity is only restricted to the M. R. MMSE applied in the frequency domain. The performance of this approach, however, is quite limited especially when used in fast fading environments. The last but not least approach, merged-pilot, provides a good compromise between hardware resources and performance as shown in the simulation section. This new approach has a considerably higher performance compared to the piecewise constant in environments characterized with high Doppler spreads. The performance gain can be described by two factors. First, the pilot spacing corresponding to the PV in the merged-pilot approach is half the spacing in the piecewise constant. Consequently, the cross correlation between the pilots and the estimated subcarriers is higher. Second, the mutual correlation provided by the pilots merged from two different OFDM symbols increases the reliability of the estimator in fading environments, especially in areas located half way between the two pilot contributing symbols. Meanwhile, computational complexity of this estimator is identical to the piecewise constant's because both methods use the same M. R. MMSE (16 pilots) estimator in frequency. Yet, the merged-pilot approach has higher memory requirements since all the intermediate OFDM symbols need to be stored before the pilots from the target pilot carrying symbols are merged. Thus, an equalization lag hits the system which is still considerably lower than the simplified robust 2-D MMSE.

²We have used the term mirrored-pilot in [2] which is literally the same as the merged-pilot. The notation has been changed to eliminate the probable ambiguity/confusion associated with the term, mirrored.

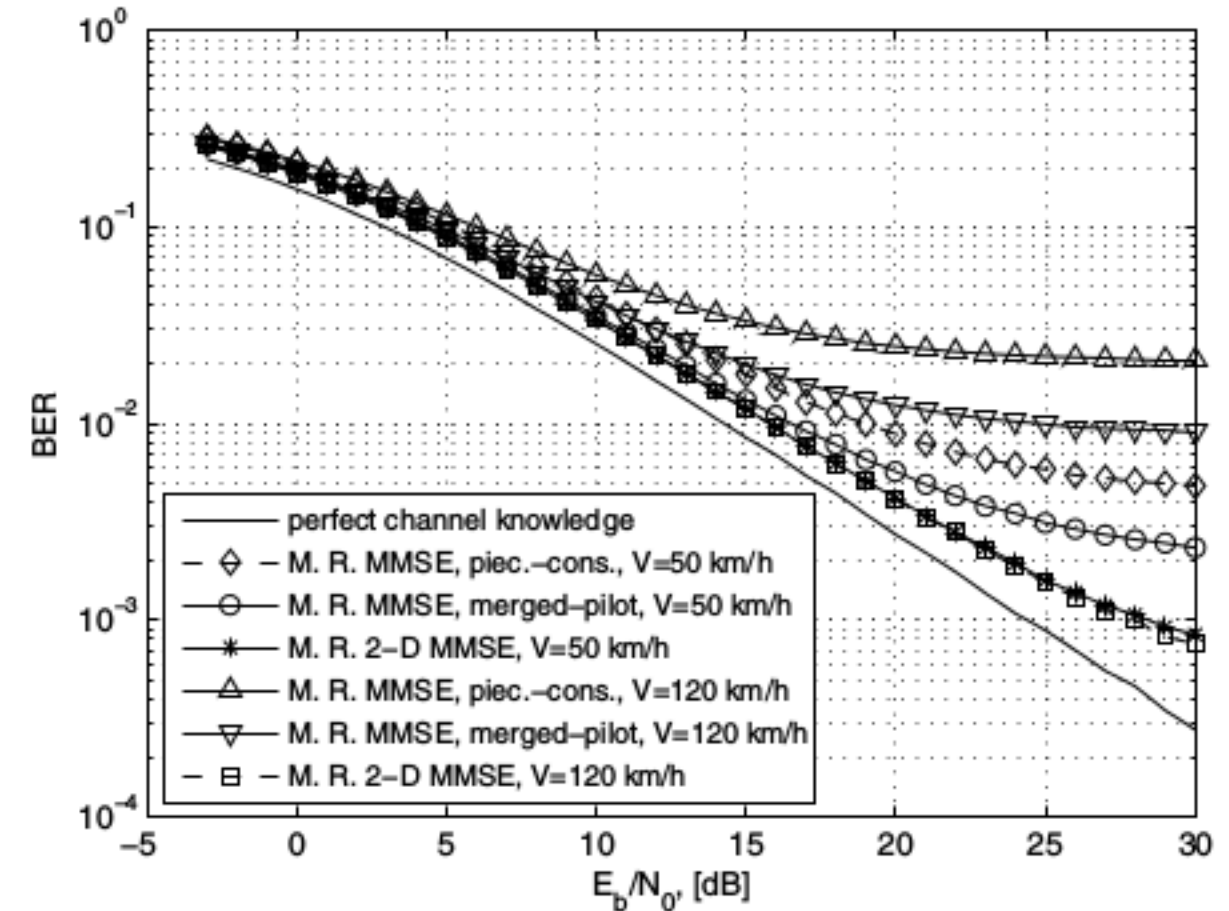

Fig. 4. LTE, uncoded BER. The simulations have been done for a 2×2 MIMO system configured for spatial multiplexing using a ZF receiver.

V. SIMULATION RESULTS

For the purposes of simulation in this paper, the LTE simulation system parameters were chosen according to Table I. To illustrate

TABLE I
LTE, SIMULATED SYSTEM PARAMETERS

FFT size	512	Δf , [kHz]	15
CP length, [n]	36	Used tones	300
Pilots/Symbol	50	PDP	$exp(-t/9)$
Carrier Freq., [GHz]	2.6	Doppler Spec.	Jakes

the performance of the estimators, the widely used Bit Error Rate (BER) measure has been used. Although the choice of estimators has been based on the conventional uncoded BER, coded BER using the standardized turbo code in LTE [5] has also been simulated for the estimators of choice proposed in this paper. Besides, the simulations have been mainly performed for a 2×2 MIMO scheme configured for spatial multiplexing using a Zero Forcing (ZF) receiver. Since the possibility of diversity has also been provided in the LTE system design, some of the simulations have also been done for a 2×2 MIMO with diversity. Fig. 4 shows the performance of the estimators for a fading environment for two different terminal speeds from an uncoded BER view point. The BER performance reveals the advantage of collecting the pilots in the merged-pilot over the piecewise constant approach. The difference becomes even more significant when the terminal speed increases. The simplest method, piecewise constant, doesn't exhibit a good level of performance for the terminal speed of 120km/h. The merged-pilot, however, offers a better performance as expected. Table II contains the complexity and memory³ requirements of each technique per RBP. The complexity as well as memory requirements of the M. R. 2-D MMSE are much higher than the other two alternatives. The excessive complexity becomes prohibitive on mobile terminals especially in case of multi-standard platforms. On the other hand, our alternative approach, the merged-pilot estimator, provides an acceptable level of performance while exhibiting a moderate complexity. The piecewise constant estimator, however, has

³Not to underestimate the required resources, we have chosen to present the memory requirements for the estimators, but the reader should be aware that parts of that memory may be shared with other processing blocks in the receiver.

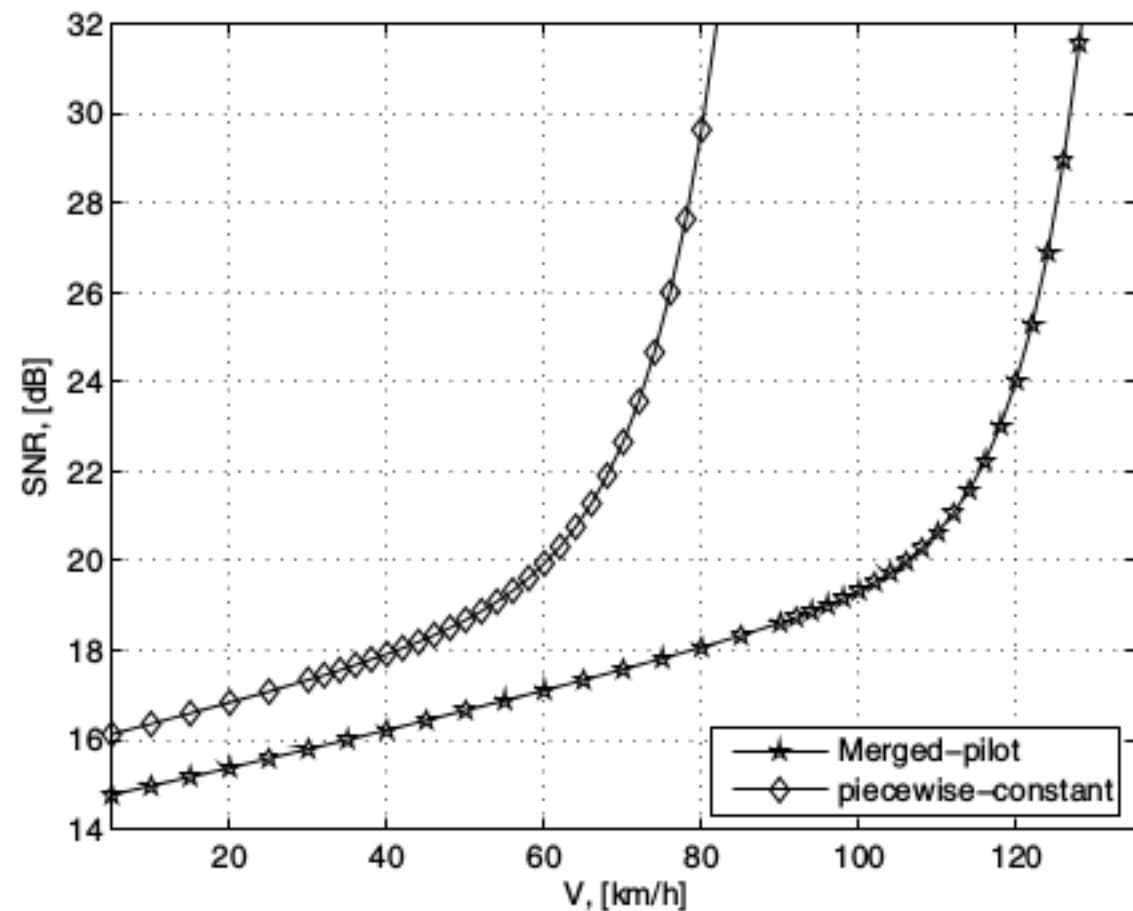

Fig. 5. LTE, SNR vs. velocity to sustain an uncoded $\text{BER} = 10^{-2}$ for a 2×2 MIMO system configured for multiplexing with ZF receiver. The figure shows the performance superiority of the merged-pilot over the piecewise constant for both slowly and fast fading wireless channels.

a significantly worse performance at high terminal speeds. Fig. 5 further describes the merits of the merged-pilot approach over the piecewise constant. It can be seen from the figure that the uncoded $\text{BER} = 10^{-2}$ breaking terminal speed is approximately 130 km/h

TABLE II

LTE, COMPLEXITY VERSUS MEMORY REQUIREMENTS FOR THE THREE ESTIMATION TECHNIQUES. THE RESULTS ARE ESTIMATED PER RBP.

Estimation technique	Complexity, [real Mul.]	Memory requirements, [byte]
piecewise-constant	2688	96
merged-pilot	2688	480
M. R. 2-D MMSE	8424	1440

for the merged-pilot approach while that value drops to almost 80 km/h for the piecewise constant. Theoretically, it is possible to sustain an acceptable uncoded $\text{BER} = 10^{-2}$ by having $\text{SNR} = 24 \text{ dB}$ for a terminal speed of 120 km/h in the merged-pilot case while the other estimator cannot sustain the $\text{BER} = 10^{-2}$ for the same speed even if the SNR is increased indefinitely. Fig. 6 demonstrates the behavior of the merged-pilot estimator when coding is used. It can be witnessed that a coded $\text{BER} = 10^{-2}$ can now be reached at $\text{SNR} = 14 \text{ dB}$ which is almost 10 dB lower compared to the uncoded BER when the system is configured for multiplexing. If the system is configured for diversity, on the other hand, the $\text{BER} = 10^{-2}$ can be reached already at $\text{SNR} = 5 \text{ dB}$. Fig. 6 also reveals that for most SNRs the simulated LTE system using our proposed estimator is only a few dBs away from one with perfect channel knowledge. We also know from experience that it is possible to have as a high SNR as 25 dB in a mobile terminal. As a result, the performance of the estimator is well within the operational SNR region of the UE and can be reliably used in practical systems.

VI. CONCLUSION

In this paper, the M. R. MMSE in frequency in conjunction with three time-domain strategies has been analyzed. The performance of the estimators for fast fading environments shows that the best trade-off between complexity and performance corresponds to the merged-pilot method as proposed in this paper. It has been shown that this low complexity estimator outperforms the conventional piecewise

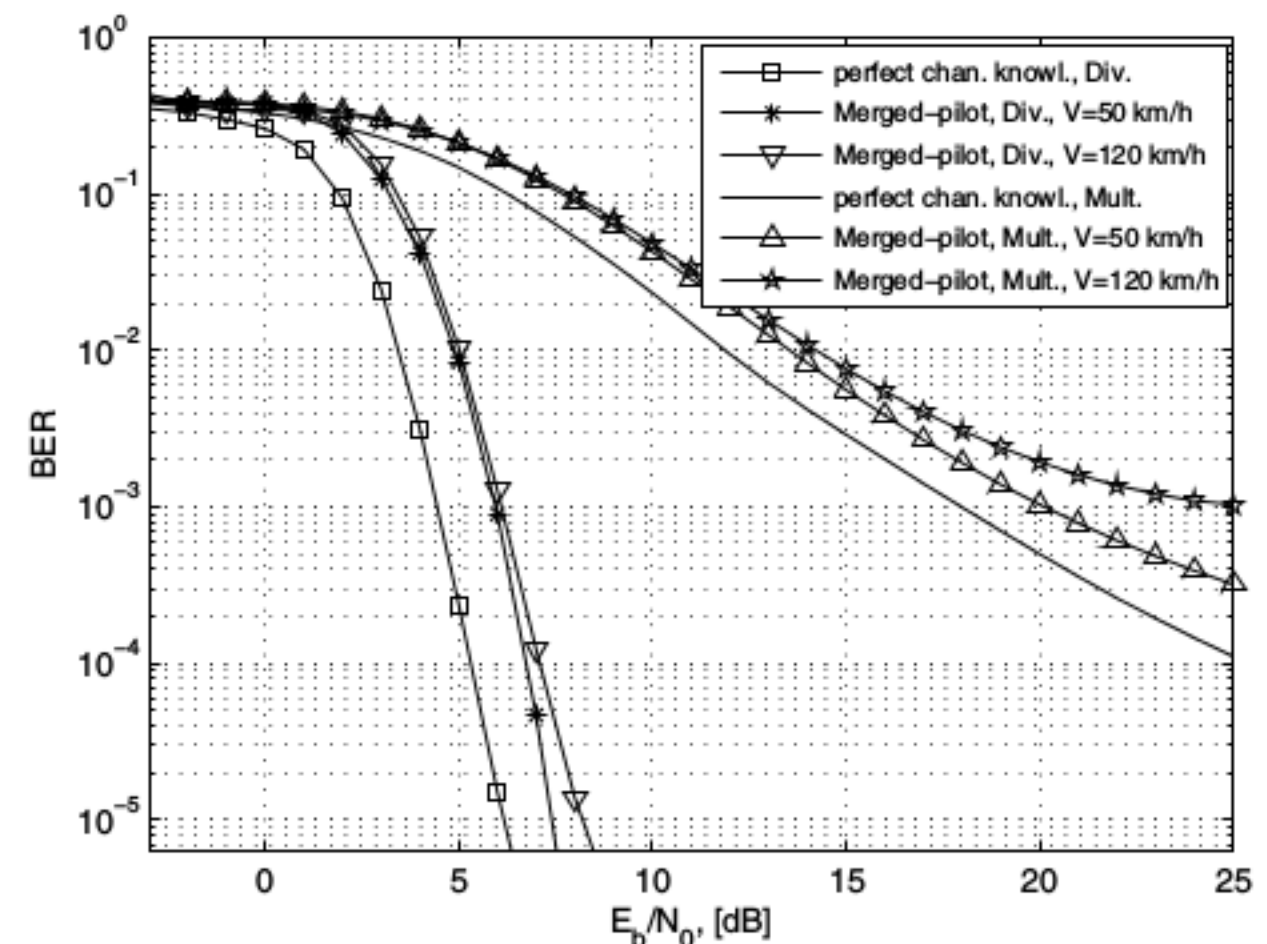

Fig. 6. LTE, coded BER performance corresponding to the merged-pilot estimator for two different terminal speeds. Simulations have been done for a 2×2 MIMO system configured for both multiplexing and diversity using a ZF receiver. The diversity results have been simulated using Alamouti precoding scheme.

constant approach in fast fading environments while exhibiting the same complexity level and waives the need for computationally complex estimators which involve additional time-domain filtering. More importantly, the structure of this estimator enables its efficient application in a multi-standard environment where LTE and DVB-H coexist [2]. Having a core estimator as such, shared between LTE and DVB-H, enables efficient hardware design which results in reduced chip area, lower power consumption, etc.

VII. ACKNOWLEDGMENTS

The authors would like to thank MULTI-BASE, a 7th Framework Program funded by the European Commission, for supporting this work.

REFERENCES

- [1] R. W. Chang, "Synthesis of band-limited orthogonal signals for multi-channel data transmission," tech. rep., Bell System Tech. J., December 1996.
- [2] F. Foroughi, J. Lofgren, and O. Edfors, "Channel estimation for a mobile terminal in a multi-standard environment (LTE and DVB-H)," in *Signal Processing and Communication Systems, 2009. ICSPCS 2009. 3rd International Conference.*, pp. 1–9, 2009.
- [3] Ericsson, "White paper: Long term evolution (LTE), an introduction," white paper, Ericsson AB, Oct. 2007.
- [4] 3GPP TS 36.201, "LTE Physical Layer - General Description," technical specifications, 2009. (Release 8).
- [5] E. Dahlman, S. Parkvall, J. Skold, and P. Beming, *3G Evolution, Second Edition: HSPA and LTE for Mobile Broadband*. Academic Press, 2008.
- [6] M. Ozdemir and H. Arslan, "CHANNEL ESTIMATION FOR WIRELESS OFDM SYSTEMS," *Communications Surveys & Tutorials, IEEE*, vol. 9, no. 2, pp. 18–48, 2007.
- [7] D. Young and N. Beaulieu, "The generation of correlated rayleigh random variates by inverse discrete fourier transform," *Communications, IEEE Transactions on*, vol. 48, no. 7, pp. 1114–1127, 2000.
- [8] M. Sandell and O. Edfors, "A comparative study of pilot-based channel estimators for wireless OFDM," tech. rep., September 1996.
- [9] O. Edfors, M. Sandell, J.-J. van de Beek, S. Wilson, and P. O. Borjesson, "OFDM channel estimation by singular value decomposition," in *Vehicle Technology Conference, 1996. 'Mobile Technology for the Human Race'.*, *IEEE 46th*, vol. 2, pp. 923–927 vol.2, 1996.
- [10] K. Manolakis, A. Ibing, and V. Jungnickel, "Performance evaluation of a 3GPP LTE terminal receiver," in *Wireless Conference, 2008. EW 2008. 14th European*, pp. 1–5, 2008.