



# LUND UNIVERSITY

## Comparison of hygrothermal measurements and calculations in a single-family wooden house in the Swedish town of Växjö

Mundt Petersen, Solof

2013

[Link to publication](#)

*Citation for published version (APA):*

Mundt Petersen, S. (2013). *Comparison of hygrothermal measurements and calculations in a single-family wooden house in the Swedish town of Växjö*. (Report TVBH; Vol. 3056). Byggnadsfysik LTH, Lunds Tekniska Högskola. <http://www.byfy.lth.se/publikationer/tvbh-3000/>

*Total number of authors:*

1

### General rights

Unless other specific re-use rights are stated the following general rights apply:

Copyright and moral rights for the publications made accessible in the public portal are retained by the authors and/or other copyright owners and it is a condition of accessing publications that users recognise and abide by the legal requirements associated with these rights.

- Users may download and print one copy of any publication from the public portal for the purpose of private study or research.
- You may not further distribute the material or use it for any profit-making activity or commercial gain
- You may freely distribute the URL identifying the publication in the public portal

Read more about Creative commons licenses: <https://creativecommons.org/licenses/>

### Take down policy

If you believe that this document breaches copyright please contact us providing details, and we will remove access to the work immediately and investigate your claim.

LUND UNIVERSITY

PO Box 117  
221 00 Lund  
+46 46-222 00 00

# Comparison of hygrothermal measurements and calculations in a single-family wooden house in the Swedish town of Växjö

S. Olof Mundt-Petersen

---

Report TVBH-3056, Lund 2013  
Building Physics, LTH



**LUND**  
UNIVERSITY

# **Comparison of hygrothermal measurements and calculations in a single-family wooden house in the Swedish town of Växjö**

S. Olof Mundt-Petersen  
Licentiate thesis

Building Physics LTH  
Lund University  
P.O. Box 118  
SE-221 00 Lund  
Sweden

ISRN LUTVDG/TVBH--13/3056--SE(228)  
ISSN 0349-4950  
ISBN 978-91-88722-47-8  
©2013 S. Olof Mundt-Petersen

## **Preface**

This report was compiled at the Department of Building Physics, Lund University, Sweden, as part of the “Framtidens trähus” (Wood framed buildings of the future) project and my doctoral studies.

The study was carried out in cooperation with SP Technical Research Institute of Sweden and the Swedish wooden house company Götenehus. I would specially like to thank Lars Olsson and Simon Dahlquist at SP and David Ulinder and Bo Karlsson at Götenehus for their valuable cooperation while carrying out the measurements. I would also like to thank my supervisor Jesper Arfvidsson and co-supervisors Lars-Erik Harderup and Petter Wallentén who have supported me while working on this project and for reviewing the report.

Lund 2013-02-28

S. Olof Mundt-Petersen



## **Summary**

This report presents measurements of relative humidity, temperature and moisture content carried out in a two floor wooden framed house in the Swedish city Växjö during the period November 2008 to December 2011. The report also presents blind WUFI 5.0 calculations using the same measurement positions and carried out during the same period under as similar boundary conditions as possible.

Measurements and calculation results of relative humidity in the studied positions are also evaluated and compared to the risk conditions for mould growth by using the Folos 2D visual mould chart.

The measurement results, calculated results and comparisons between the measurements and calculations have been evaluated using Folos 2D visual mould charts which show the deviations between measured and calculated values. These are briefly discussed at the end of the report. The results from measurements, calculations and comparisons between measured and calculated values will be used and further evaluated in future studies and research projects.





# Contents

Preface.....	3
Summary .....	5
1 Introduction.....	9
1.1 Background.....	9
1.2 Aim.....	9
1.3 Limitations .....	9
1.4 Intended readers .....	9
2 Method .....	10
2.1 Blind comparison between measured and calculated values .....	10
3 Materials.....	10
4 Measuring and calculation periods .....	11
5 Boundary and initial conditions for calculations .....	11
5.1 Outdoor climate boundary condition data.....	11
5.2 Indoor climate boundary condition data.....	16
5.3 Air change rate/ Ventilation in air gap behind the cladding .....	16
5.4 Roof boundary conditions .....	16
6 Studied house and positions .....	17
7 Results .....	23
7.1 Position 1 .....	23
7.2 Position 2 .....	31
7.3 Position 3 .....	39
7.4 Position 4 .....	47
7.5 Position 5 .....	55
7.6 Position 6 .....	65
7.7 Position 7 .....	73
7.8 Position 8 .....	81
7.9 Position 9 .....	89
7.10 Position 10 .....	97
7.11 Position 11 .....	105
7.12 Position 12 .....	113
7.13 Position 13 .....	123
7.14 Position 14 .....	133
7.15 Position 15 .....	143

7.16 Position 16 .....	143
7.17 Position 17 .....	153
7.18 Position 18 .....	163
7.19 Position 19 .....	171
7.20 Position 20 .....	181
7.21 Position 21 .....	191
7.22 Position 22 .....	201
7.23 Position 23 .....	209
7.24 Position 24 .....	217
8 Discussion and analysis of the results .....	225
8.1 Walls .....	225
8.2 Attic.....	226
9 Conclusions.....	226
10 References.....	227

# **1 Introduction**

This report presents measurements of relative humidity (RH), temperature (T) and moisture content (MC) in a number of positions in the studied house. Measurements of relative humidity and temperature are also compared with blind WUFI 5.0 calculations. Measured moisture contents have also been compared with blind WUFI 5.0 calculated values in positions where this was possible. The risk of mould growth has also been evaluated in the studied positions.

This study is part of the Swedish research project “Framtidens trähus” (Wood framed buildings of the future) and was mainly carried out in a cooperation between Lund University, SP Technical Research Institute of Sweden and the Swedish wooden house company Götenehus.

The report includes a brief discussion based on the results. The results of measurements, calculations and comparisons between measured and calculated values will be used and further evaluated in future studies and research projects.

A separate report (Mundt-Petersen, S.O., 2013) has been compiled which includes a broad analysis, discussion and conclusions with regard to the comparisons between measured and blind WUFI 5.0 calculated values. This report also discusses the possibility of using WUFI 5.0 in the Swedish design process for Swedish constructions and Swedish climate conditions (Mundt-Petersen, S.O., 2013).

## **1.1 Background**

The project “Wood framed buildings of the future” started in November 2007. In 2008 and 2009 several wireless sensors were installed in five differently designed wood framed houses during the construction process. The sensors measured temperature, RH and MC in order to make it possible to evaluate the climate conditions and risk of mould growth in different positions in different wood framed constructions (Framtidens trähus, 2012).

## **1.2 Aim**

The aim of this report is to present the measurement results for temperature, RH and MC in the studied positions in the studied house. The report also aims to present comparisons between measurements and blind calculations of temperature and RH, and MC where possible, carried out using the transient heat and moisture calculation tool WUFI 5.0 (Mundt-Petersen, S.O., 2013). Furthermore, the report aims to evaluate the risk of mould growth in the studied positions.

## **1.3 Limitations**

There are a number of limitations and sources of error with regard to the measurements, comparisons of measured and calculated values and evaluations of the mould growth risk. These limitations are described in a separate report (Mundt-Petersen, S.O., 2013).

## **1.4 Intended readers**

This report has been written for the Swedish wooden house companies that participated in the “Wood framed buildings of the future” project and whose wooden framed constructions were studied.

## 2 Method

The comparisons between measured and calculated values were blind comparisons, i.e. they were verified without knowing the measurement results before the comparisons with the unadjusted calculated results were made. More detailed descriptions of the measurement method, the construction of the calculation model and the method of comparison between the measured and calculated values are provided in a separate report (Mundt-Petersen, S.O., 2013).

Measurements of temperature, RH and MC are presented in Folos 2D visual mould charts and additional charts together with comparisons with the blind WUFI 5.0 calculations and evaluations of the risk of mould growth. The Folos 2D visual mould chart is described in more detail in a separate report (Mundt-Petersen, S.O., 2012). Additional charts also show measured moisture content and, if it was possible, calculated moisture content. Vapour contents were calculated from measured and calculated values and compared. If there was a lack of measured values, the vapour content is shown as zero. There are also additional charts showing the magnitude of deviation between measured and calculated temperature and relative humidity.

Results from positions where the measuring sensor initially failed are not presented and consequently there are gaps in the numbering sequence of the measurement positions.

### 2.1 Blind comparison between measured and calculated values

Initially, measuring sensors for temperature, relative humidity and moisture content were mounted at different depths and locations in the walls during the construction phase. The construction phase was monitored to establish any possible deviations between the drawings and the real conditions in the built walls. Hourly measurements of temperature, relative humidity and moisture content for each specific position were then separately stored by a measurement collector, inaccessible to the persons involved in evaluating the calculation tool.

When the measurements were carried out, calculation models of each studied position were made. The calculation models were based on drawings and photos from the construction phase with the intention of reflecting as real conditions as possible. In 2012, blind calculations were carried out for each studied position without knowing the measured results. After the blind calculations had been completed and sent to the measurement collector, the previously inaccessible measurements were retrieved and compared to the calculated values.

Note that it was possible to make adjustments to the calculation models to achieve better correlation between the measured and calculated values in almost all the studied positions. However, this was not done since this was a blind verification.

## 3 Materials

The presented measurements, comparisons of measurements and calculations and evaluations of the risk of mould growth were carried out in a wooden framed single-family house in the city Växjö built by the Swedish wooden house company Götenehus. The building was a two-floor-single family house with a construction area of 160.5 m<sup>2</sup> and a living area of 183.9 m<sup>2</sup>. The house was built on a concrete ground slab with wooden walls, a wooden slab and a wooden roof frame. An underfloor heating system was installed in the concrete slab. Wall, slab and roof elements were constructed at

Götenehus factory in Götene during October 2008. The house was then constructed in Växjö with starting 27 October 2008. The house was inhabited 22 March 2009.

## **4 Measuring and calculation periods**

Most of the measurements started on 8 November 2008. Calculations were carried out starting 27 October 2008 in all positions since this was the day the house was built on place. The comparison between measured and calculated values starts at the time when measuring data were available. Indoor climate measurements started 7 April 2009. Comparisons from November 2008 to April 2009 may be uncertain since uncompleted indoor climate are used and there were no inhabitants.

Measuring sensors have been mounted in cooperation with Lars Olsson at SP and Götenehus AB that have mounted sensor 1, 2, 3, 7, 9 and 10. Measuring data was collected by SP Trä Skellefteå. During some periods there were problems regarding local transmission of measuring data from the measuring sensors to the local measurement data collector (Sandberg, K., 2011). Some measuring positions may therefore lack long periods of measured data.

## **5 Boundary and initial conditions for calculations**

The climate boundary conditions and initial conditions aim to reflect as real conditions as possible during the measuring period. Specific parameters and initial set values are presented in a separate report (Mundt-Petersen, S.O., 2013). The materials used are also listed separately (Mundt-Petersen, S.O., 2013). However, the materials used are briefly presented in connection with the WUFI 5.0 model for each separate position.

The in- and outdoor climate boundary conditions used are presented below. This is done together with a comparison and check against other available climate data in the area. The methods for finding additional climate data during periods when this is lacking, in order to provide complete in- and outdoor climate boundary conditions, are described in a separate report (Mundt-Petersen, S.O., 2013). Comparisons and checks regarding other available climate are also described in the same report (Mundt-Petersen, S.O., 2013).

### **5.1 Outdoor climate boundary condition data**

The boundary conditions data used for each parameter are presented below. The charts also include a comparison with other available climate data. The amount of supplemented data, which were the same amount of lack of data, is given in percent for each year for each climate parameter.

Outdoor short-wave radiation absorption, dependent on color, is assumed to be 0.2 (normal bright plaster) on walls and 0.88 on roofs (bitumen black roof paper).

Note that hourly climate data was used in the calculations and three-hourly data was used in order to check the hourly data. In some cases the three-hourly data was also used to supplement periods of lacking data, as described in a separate report (Mundt-Petersen, S.O., 2013). Micro climate data available from own mounted sensors was only used in order to check possible deviations and defects in the hourly data.

The hourly outdoor climate, including radiation data, and three hourly data used were captured from a climate station in Växjö. However, there was a lack of diffuse radiation readings why this data were created from a model based on global radiation (Mundt-Petersen, S.O., 2013).

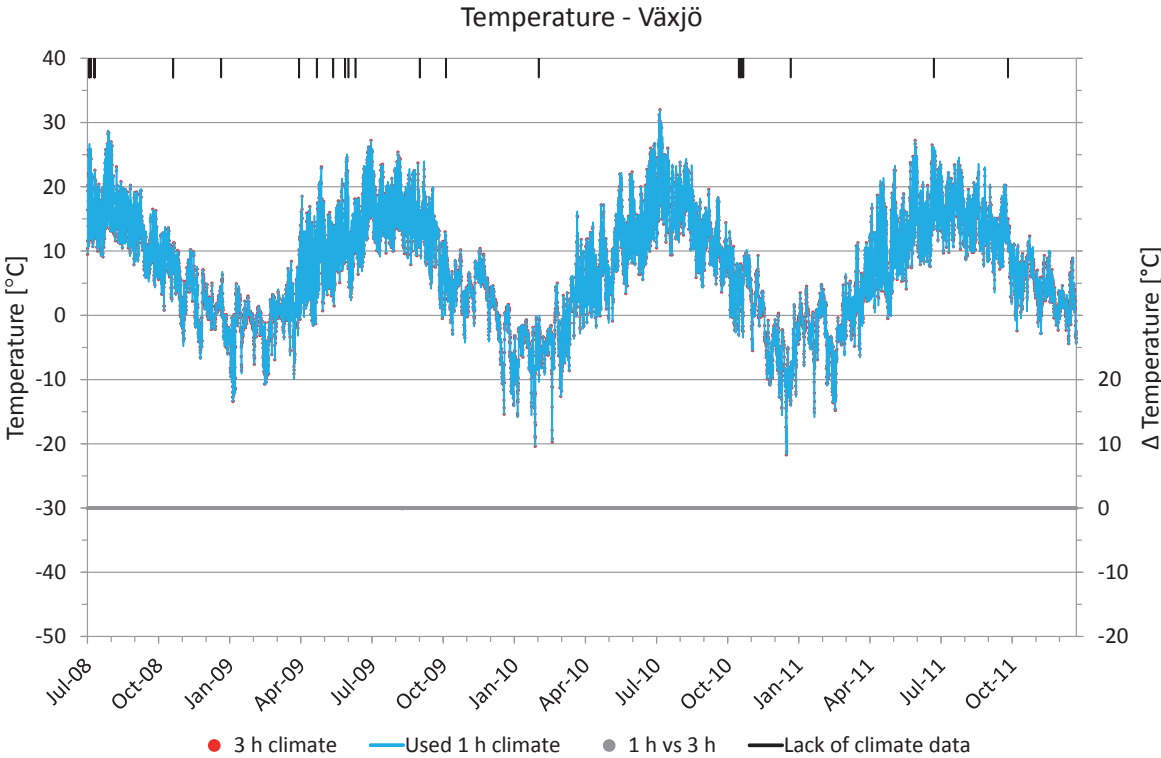

Figure 5.1.1. Used temperature data compared with other available climate data. Lack of data, in percent, that was supplemented: 2008 – 0.29 %, 2009 – 0.16 %, 2010 – 0.08 %, 2011 – 0.03 %.

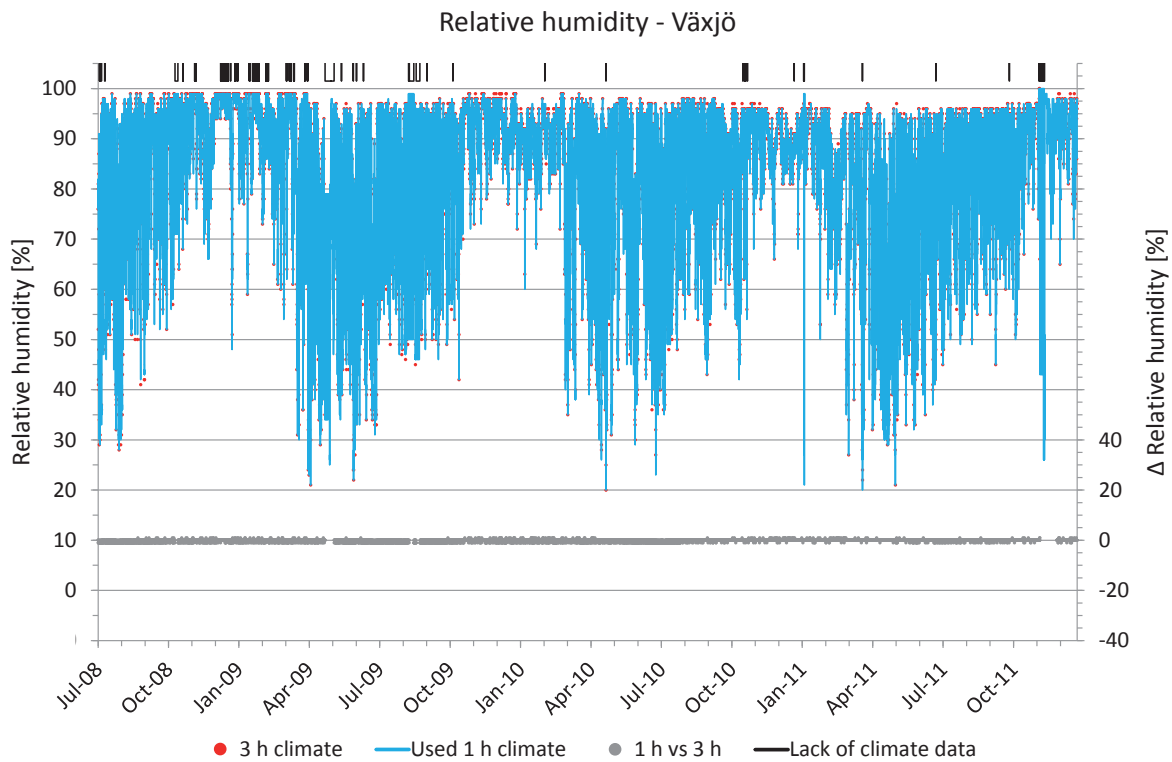

Figure 5.1.2. Used RH data compared with other available climate data. Lack of data, in percent, that was supplemented: 2008 – 2.52 %, 2009 – 8.12 %, 2010 – 0.09 %, 2011 – 1.76 %.

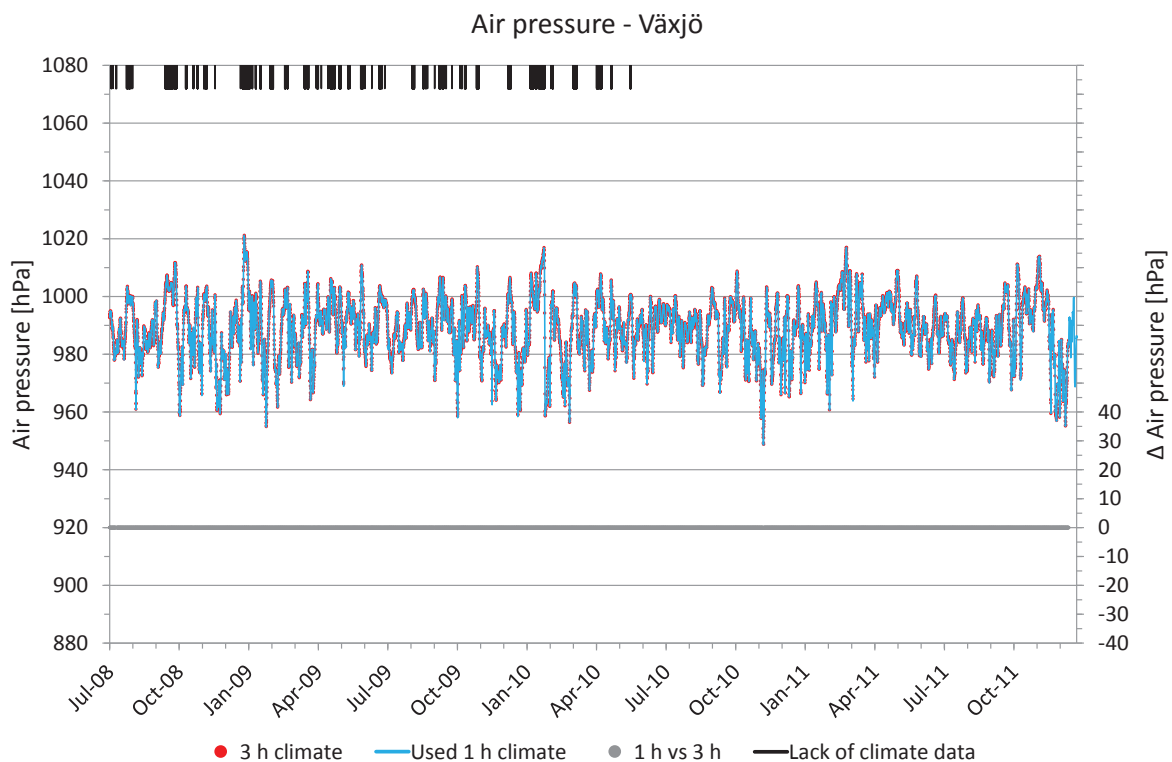

Figure 5.1.3. Used air pressure data at weather station height above sea level compared with other available climate data. Lack of data, in percent, that was supplemented: 2008 – 5.78 %, 2009 – 8.84 %, 2010 – 7.05 %, 2011 – 11.22 %.

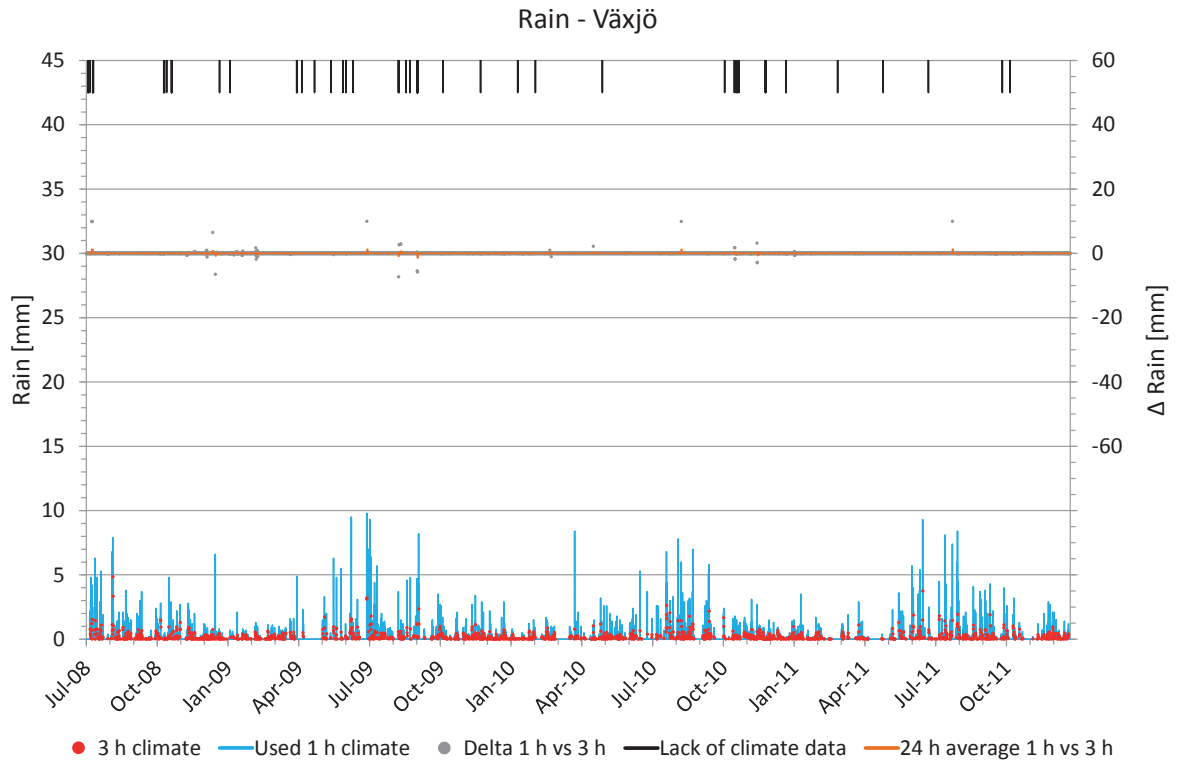

Figure 5.1.4. Used rainfall data compared with other available climate data. Lack of data, in percent, that was supplemented: 2008 – 0.66 %, 2009 – 0.68 %, 2010 – 0.47 %, 2011 – 0.29 %.

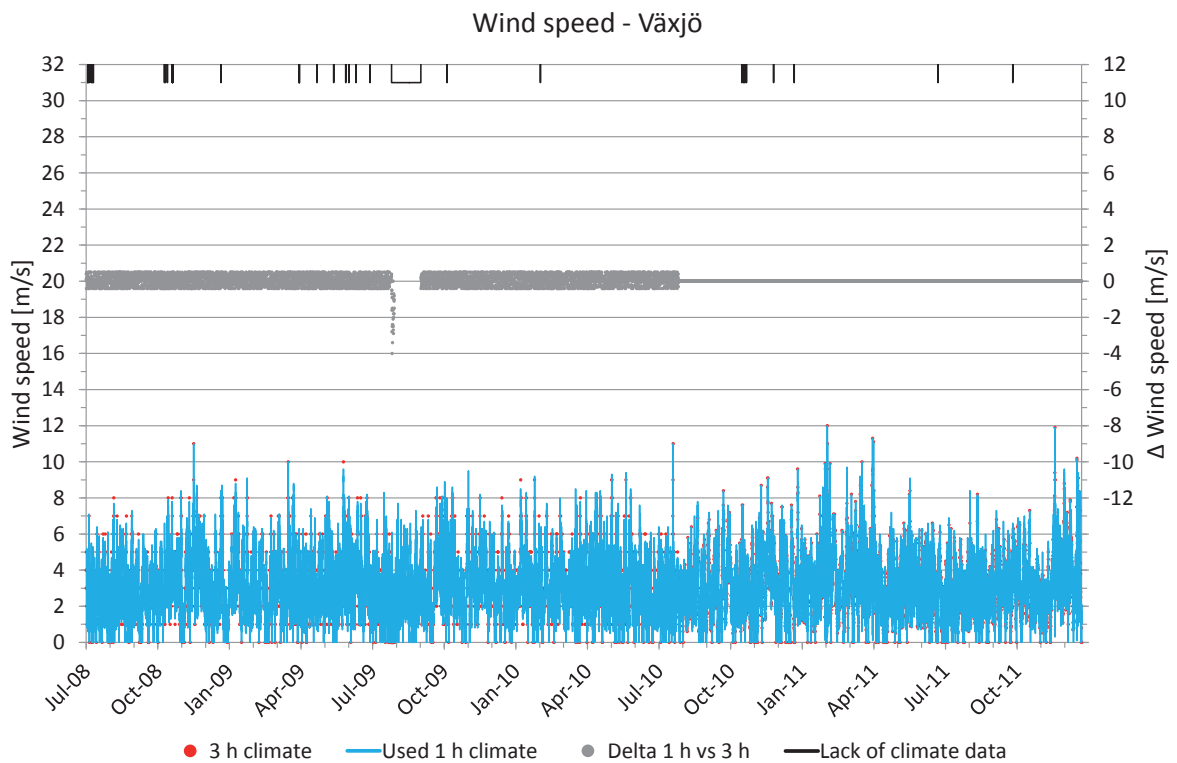

Figure 5.1.5. Used wind speed data compared with other available climate data. Lack of data, in percent, that was supplemented: 2008 – 0.37 %, 2009 – 10.48 %, 2010 – 0.17 %, 2011 – 0.06 %.



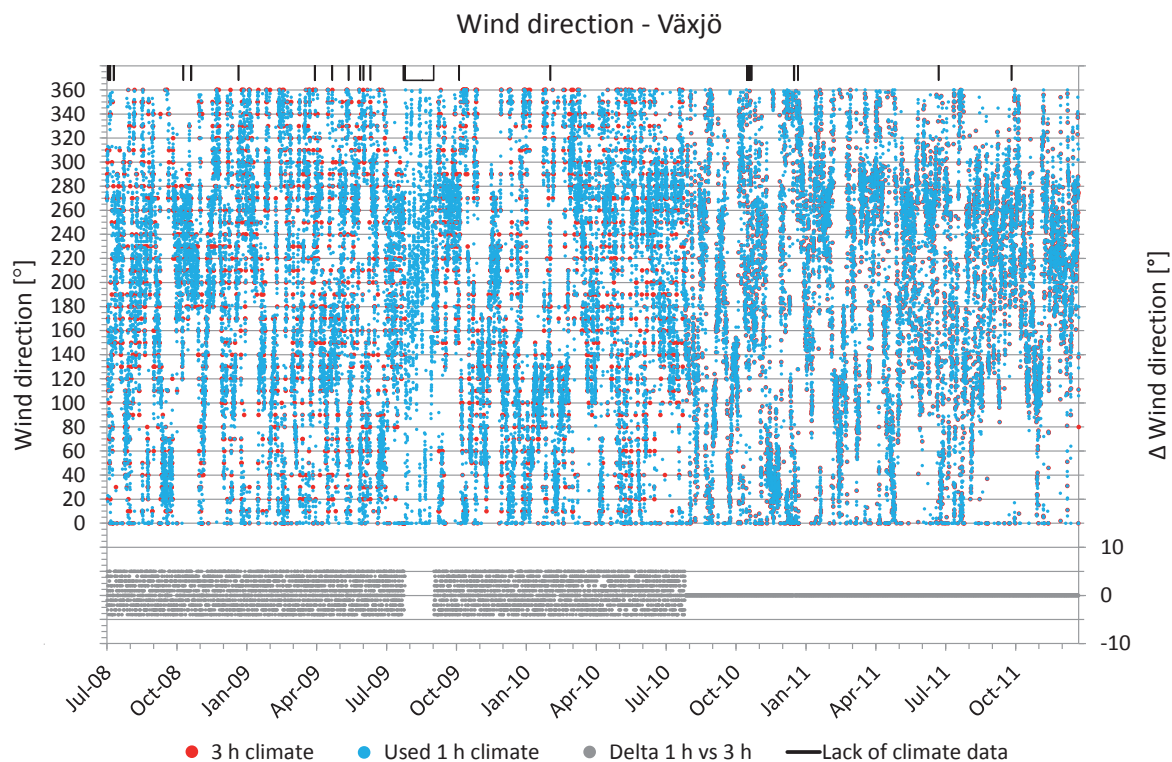

Figure 5.1.6. Used wind direction data compared with other available climate data. Lack of data, in percent, that was supplemented: 2008 – 0.32 %, 2009 – 10.81 %, 2010 – 0.42 %, 2011 – 0.06 %.

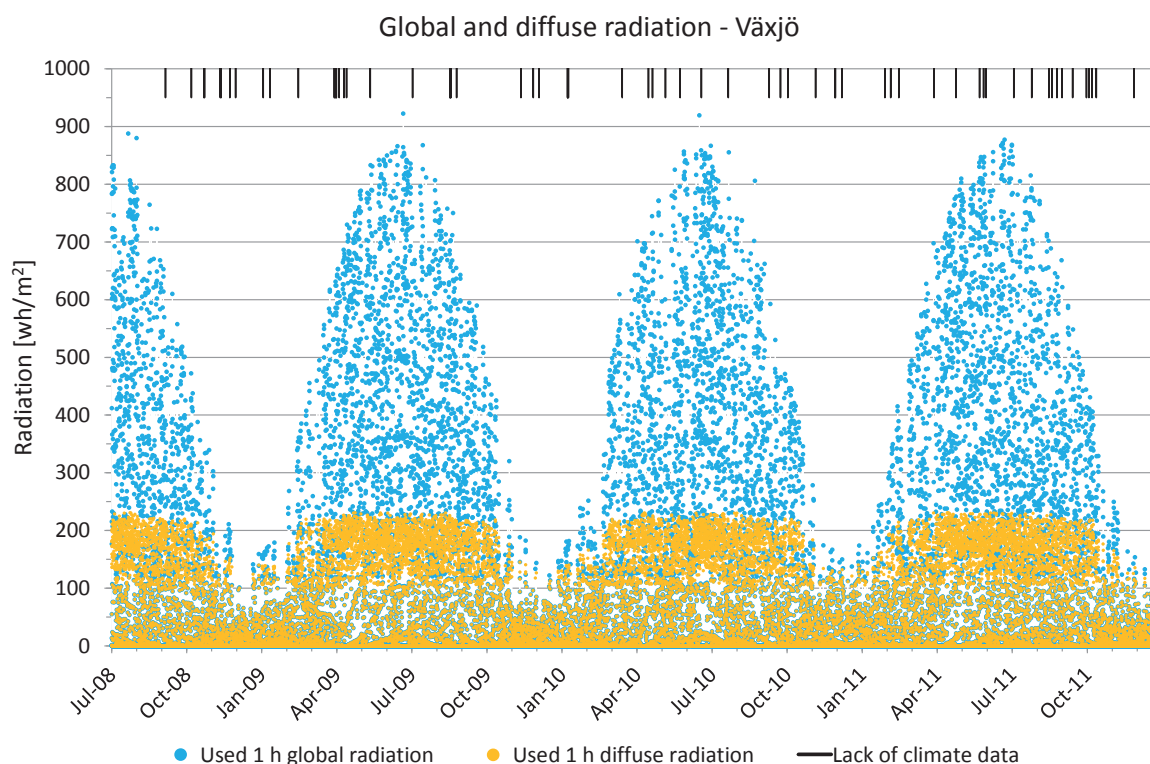

Figure 5.1.7. Used global and diffuse radiation data. Lack of global radiation data, in percent, that was supplemented: 2008 – 0.09 %, 2009 – 0.49 %, 2010 – 0.22 %, 2011 – 0.24 %. Diffuse radiation data was created from global radiation data (Mundt-Petersen, S.O., 2013).

## 5.2 Indoor climate boundary condition data

The indoor climate boundary conditions used are presented below. Periods with lack of data have been supplemented as described in a separate report (Mundt-Petersen, S.O., 2013).

Calculations in outdoor bathroom walls have assumed 99 % RH for the boundary conditions on the inside (Jansson, A., 2006).

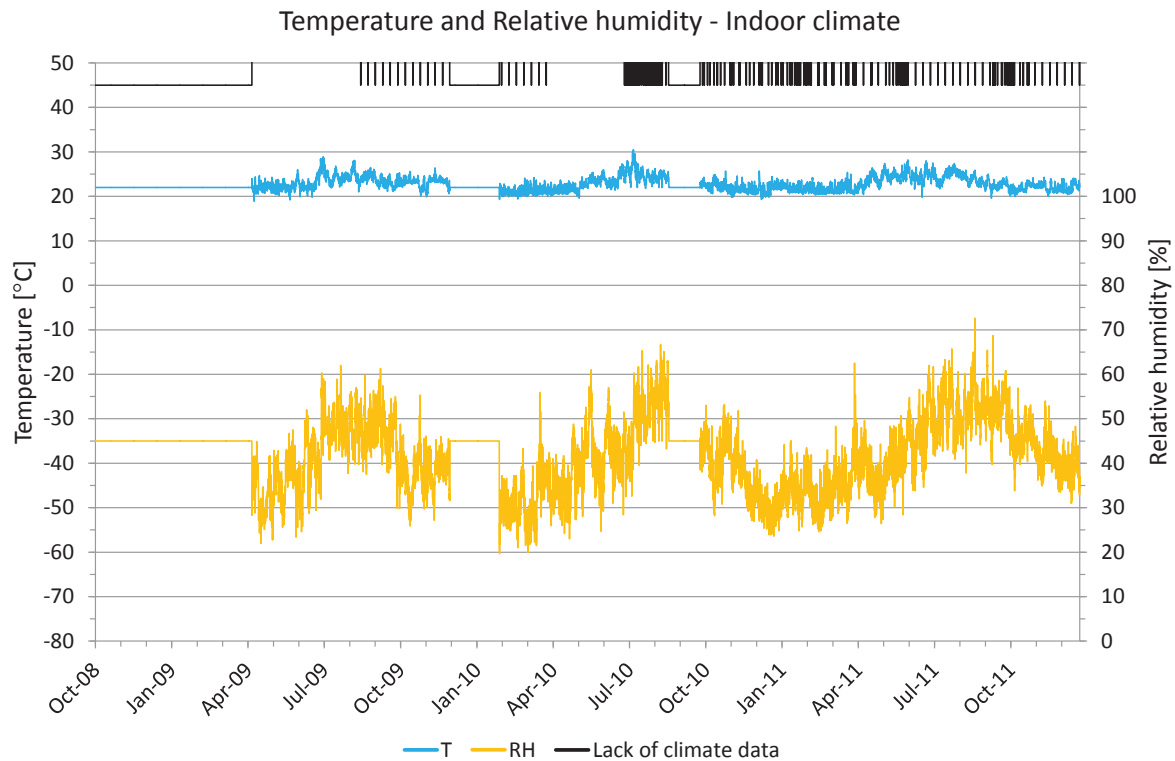

Figure 5.2.1. Used indoor temperature and relative humidity data. Lack of data, in percent, that was supplemented: 2008 – 100%, 2009 – 34.79 %, 2010 – 21.16 %, 2011 – 1.38 %.

## 5.3 Air change rate/ Ventilation in air gap behind the cladding

Previous studies show that the air flow in the air gap varies depending on several of factors (Falk 2013). However, if the air change rate (ACH) in the air gap is high enough to handle all potential moisture in the gap, the influence of a higher ACH in the air gap is negligible (Hägerstedt 2010A, Hägerstedt 2011). Previous studies show that an air flow of 30 ACH in the air gap is reasonable in the case of ventilated air gaps behind the cladding. An air flow of 30 ACH has therefore been used in the walls studied in this report (Hägerstedt 2010A, Hägerstedt 2010B).

## 5.4 Roof boundary conditions

The roof was full insulated with a ventilated air gap close to the outer tongued and grooved wood located below the roof membrane. No specific assumptions and attic model have therefore been made in the calculations model. The air gap was simply treated as a ventilated air gap in the same way as the façade air gap was treated.

The roof is a flat roof with a roof angle of four degrees only directed in one direction, facing northwest.

## **6 Studied house and positions**

The locations of the studied positions are shown in the figures on the following pages. In connection with each studied position a more detailed specification and drawing of the position is also given. In some cases photos, showing the sensor, are provided in the results chapter in connection with the part in which each studied position is presented in detail.

The locations of the studied positions were mainly chosen for two reasons. One was to study the positions where previous knowledge and experience had shown a high frequency of damage. The second was to have a couple of positions in a row at different depths in the wall in order to obtain purer measurements and more reliable conditions in order to verify the WUFI 5.0 calculation tool.

The choice of the studied house and its location was governed by the potential for new-build houses from the housing company participating in the study.

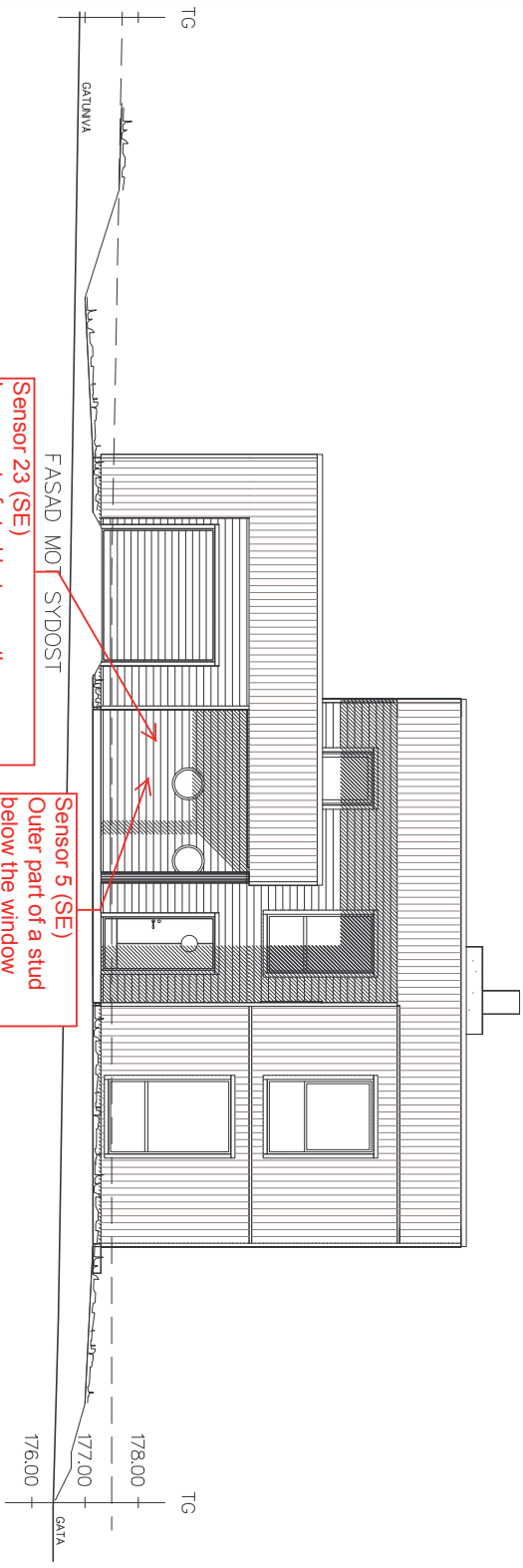

**Sensor 23 (SE)**  
Inner part of stud between the vapour barrier and bathroom water barrier

**Sensor 5 (SE)**  
Outer part of a stud below the window

**Sensor 24 (NE)**  
Inner part of stud between the vapour barrier and bathroom water barrier

**Sensor 10 (NE)**  
Air gap behind the facade panel

**Sensor 22 (NE)**  
Inner part of the slab close to the iron beam

**Sensor 11 (NE)**  
Inner part of the slab

BEFINTLIG MARK  
BLIVANDE MARK

FÖRESLAGNA HÖJDER:  
SH +177.30  
FGG +177.25

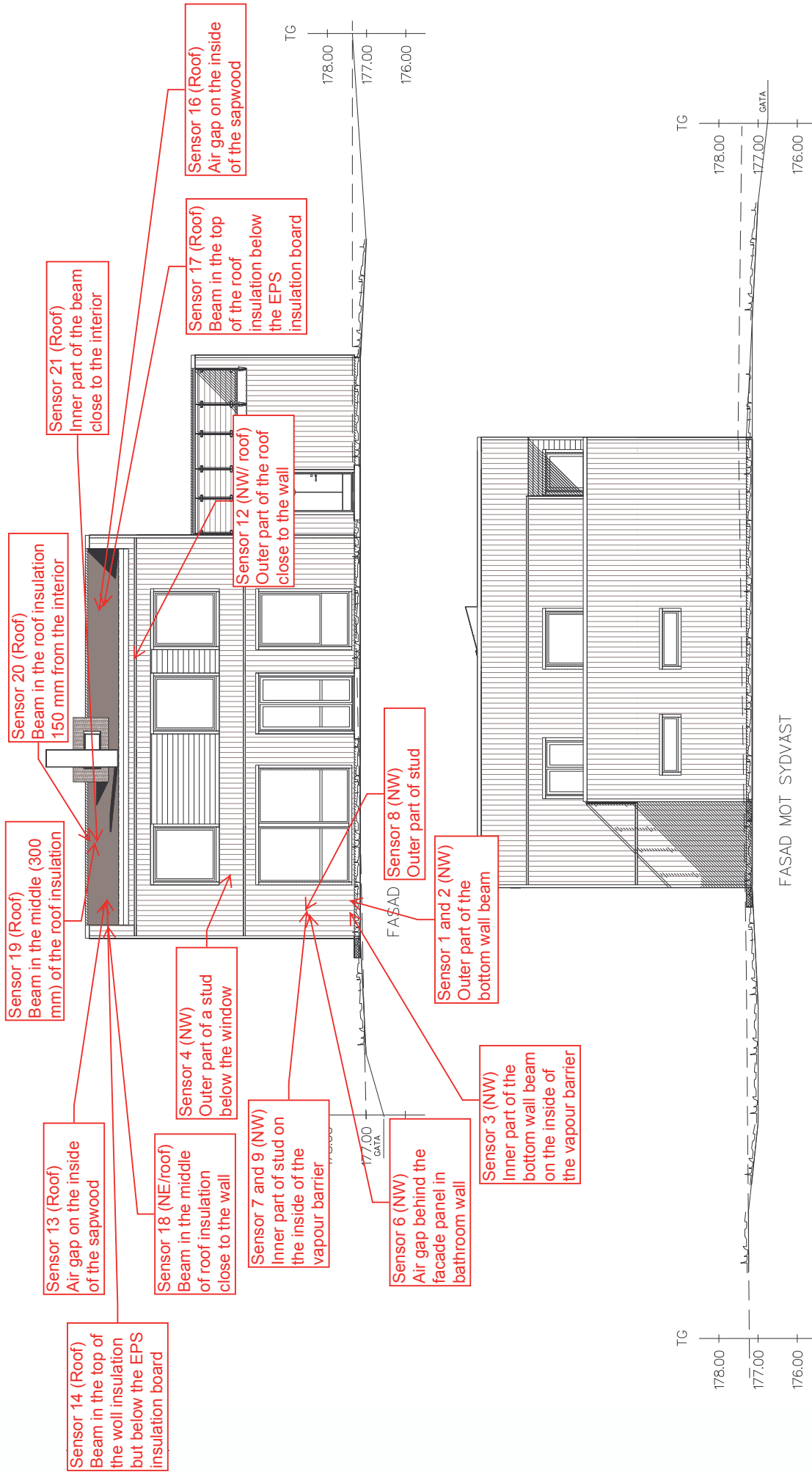

FÖRESLAGNA HÖJDER:  
 SH +177.30  
 FGG +177.25

BEFINTLIG MARK  
 BLIVANDE MARK

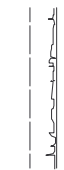

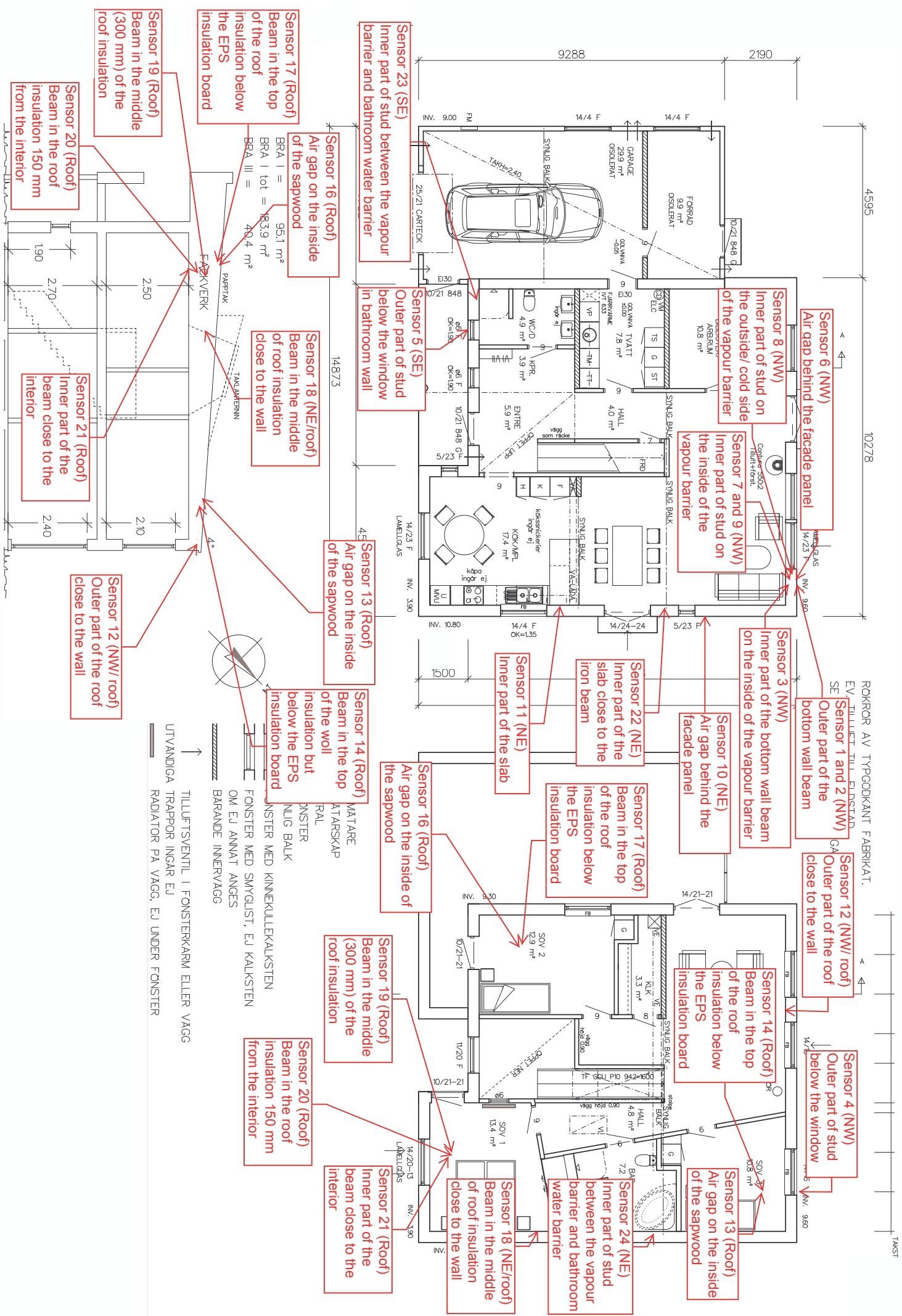

Taklutning  4°  
 ---

Våningshöjd  2,5  
entrepian  2,7

Grundläggning  Platta på mark  
 Torpargrund

Våningshöjd  2,5  
överplan  2,7

Fasadmaterial  Trä, typ:-----  
 Puts  
 Tegel

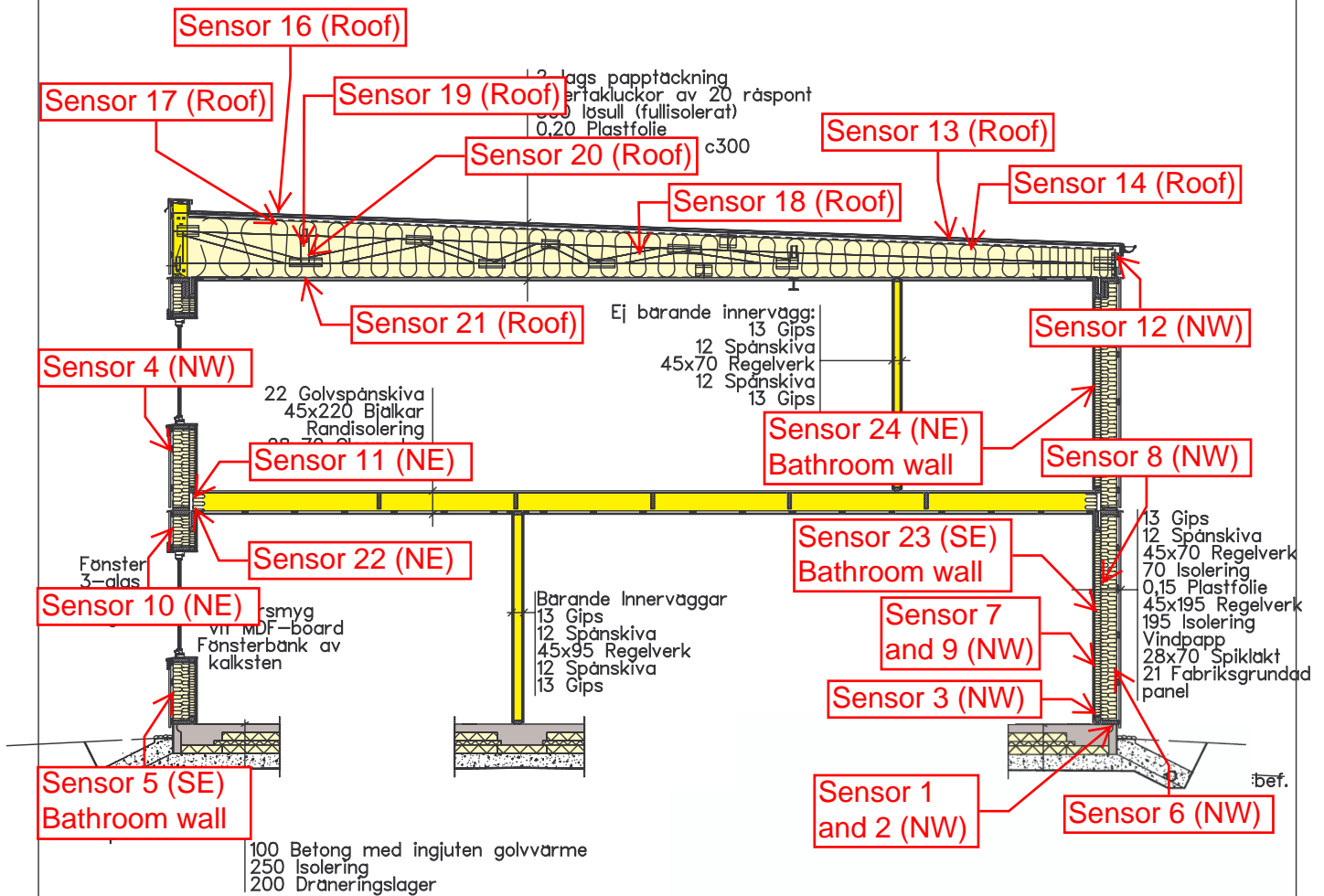





## 7 Results

### 7.1 Position 1

The locations of the measured and calculated position are shown in the drawings and figures below. The studied position is located in a wall facing northwest on the first floor.

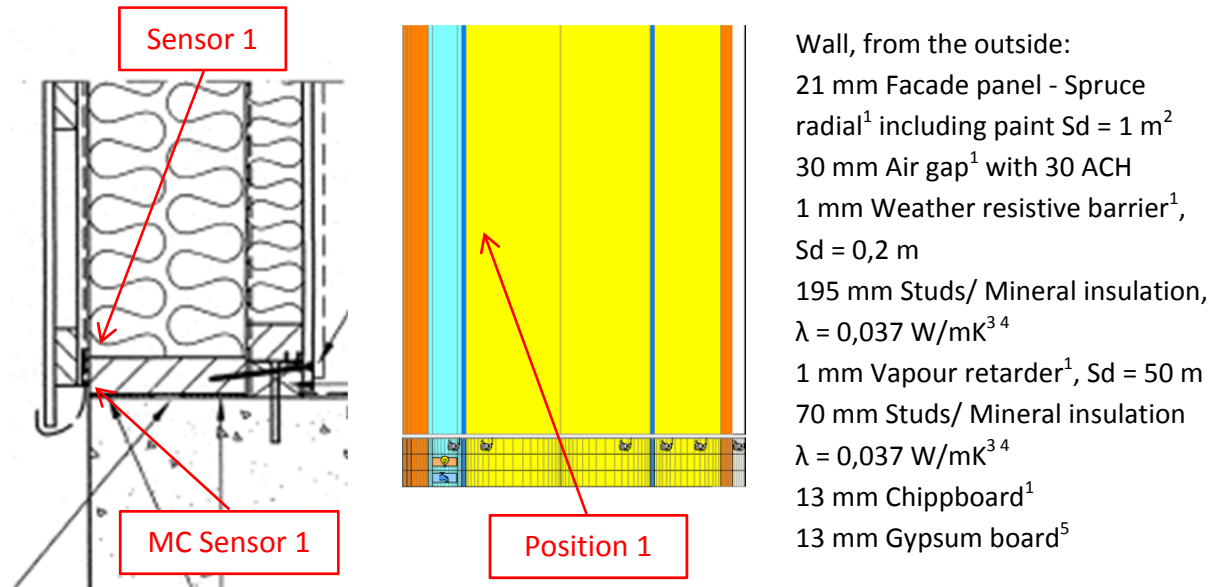

Figure 7.1.1. Vertical cross sectional drawing and WUFI calculation model showing the studied position. 1. IBP, 2012, 2. Nevander, L-E., 1994, 3. IEA Annex 24, 1996, 4. Paroc, 2002, 5. Krus, M., 1996.

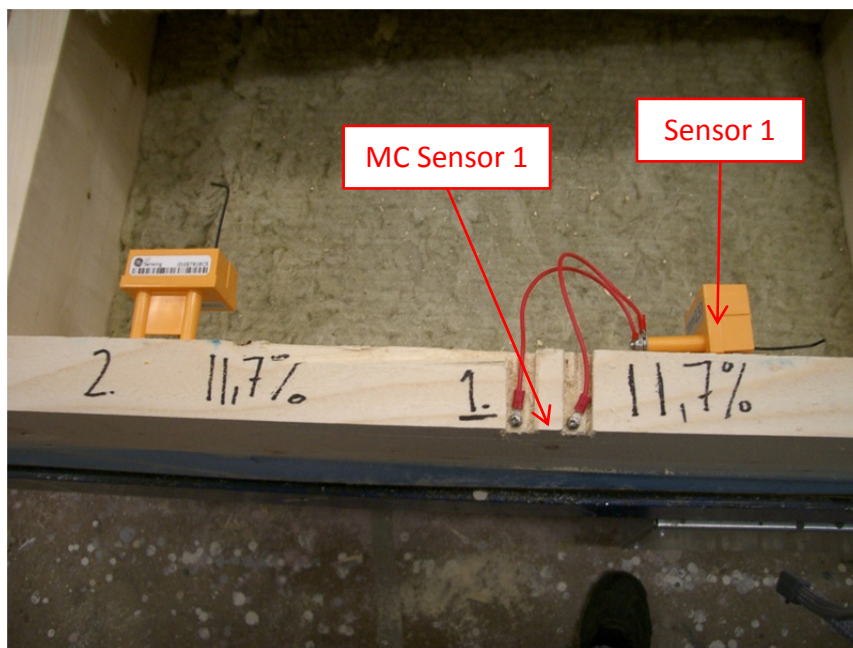

Figure 7.1.2. Location of the studied position. Photo: Götenehus AB.

A perfect match between the measured and calculated values cannot be expected due to e.g. the influence of two- and three-dimensional effects and the accuracy of the sensors.

**Year 2008**

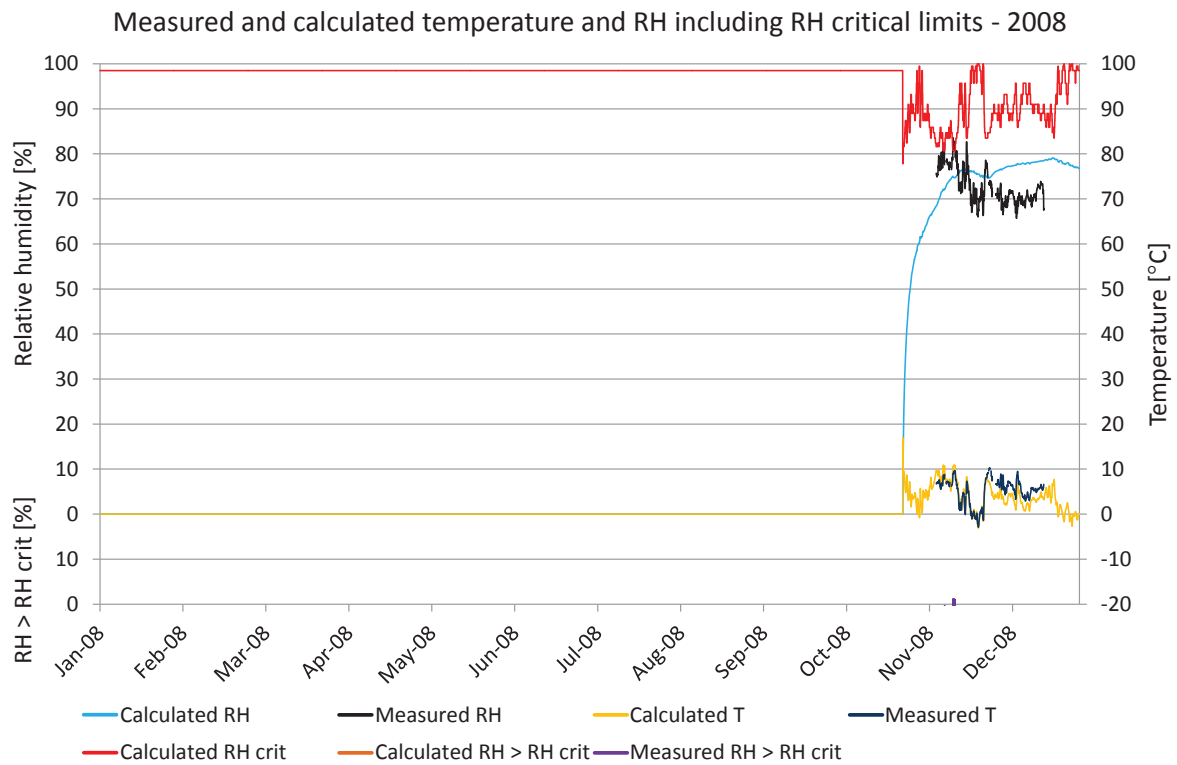

Figure 7.1.3. Comparisons between measured and calculated temperature and relative humidity. Calculated temperature (yellow), measured temperature (dark blue), calculated RH (turquoise), measured RH (black),  $RH_{crit}$  for calculated values (red), calculated  $RH > RH_{crit}$  (light brown), measured  $RH > RH_{crit}$  (purple).

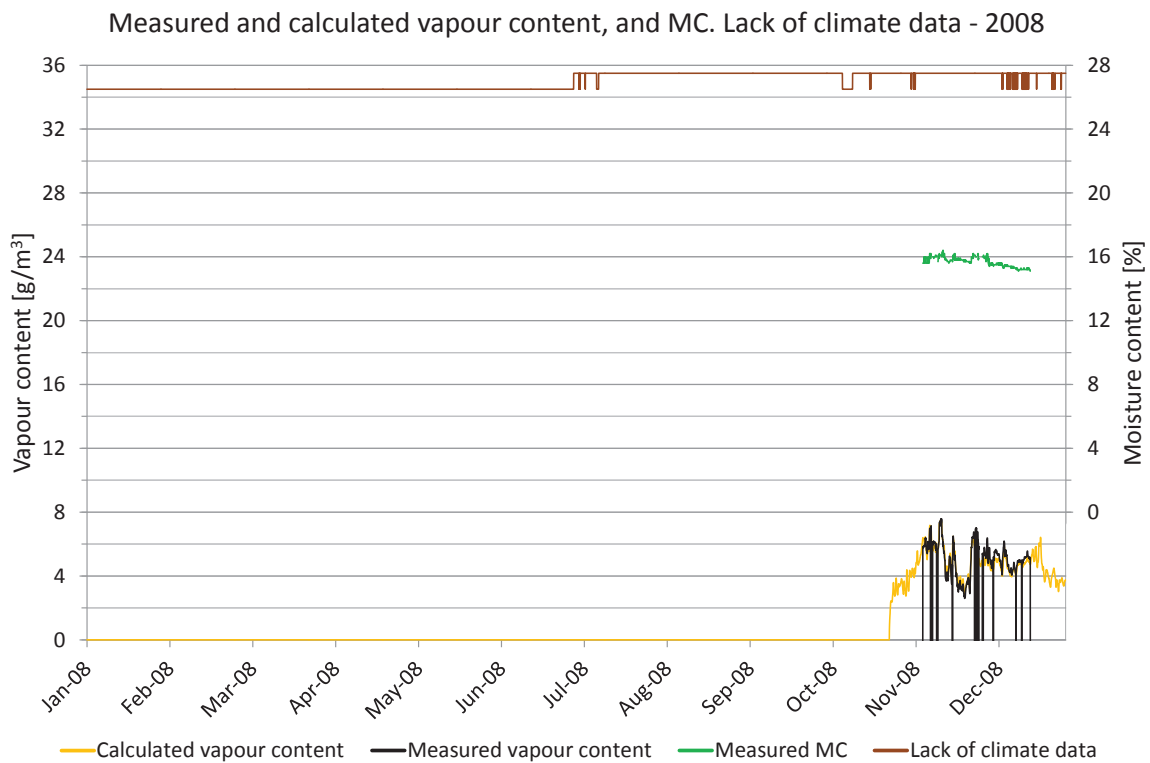

Figure 7.1.4. Measured moisture content, periods lacking climate data and comparisons of vapour content. Vapour content for calculated values (yellow) and measured values (black). Moisture content (green), periods with lack of climate data (brown).

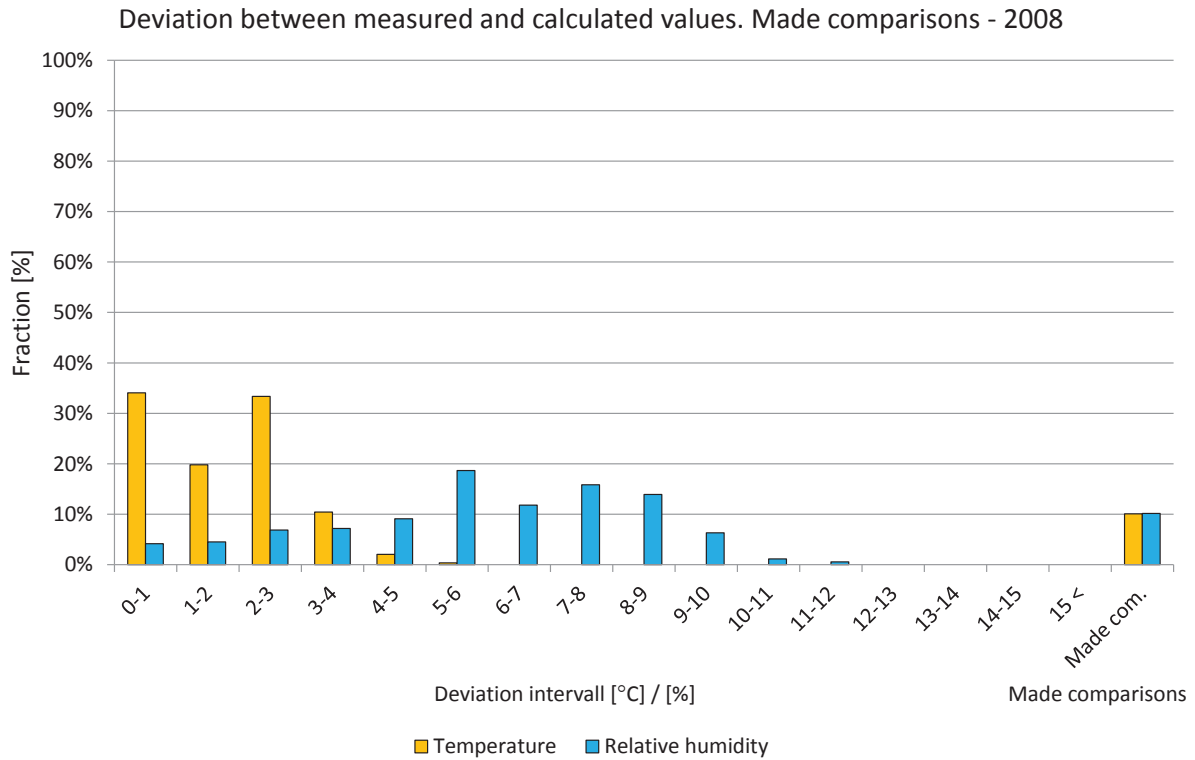

Figure 7.1.5. Deviations in comparisons shown in intervals from 0 to 15 °C or %. The two right-hand bars show the percentage of comparisons during the year. Temperature (yellow) and relative humidity (light blue).

### Year 2009

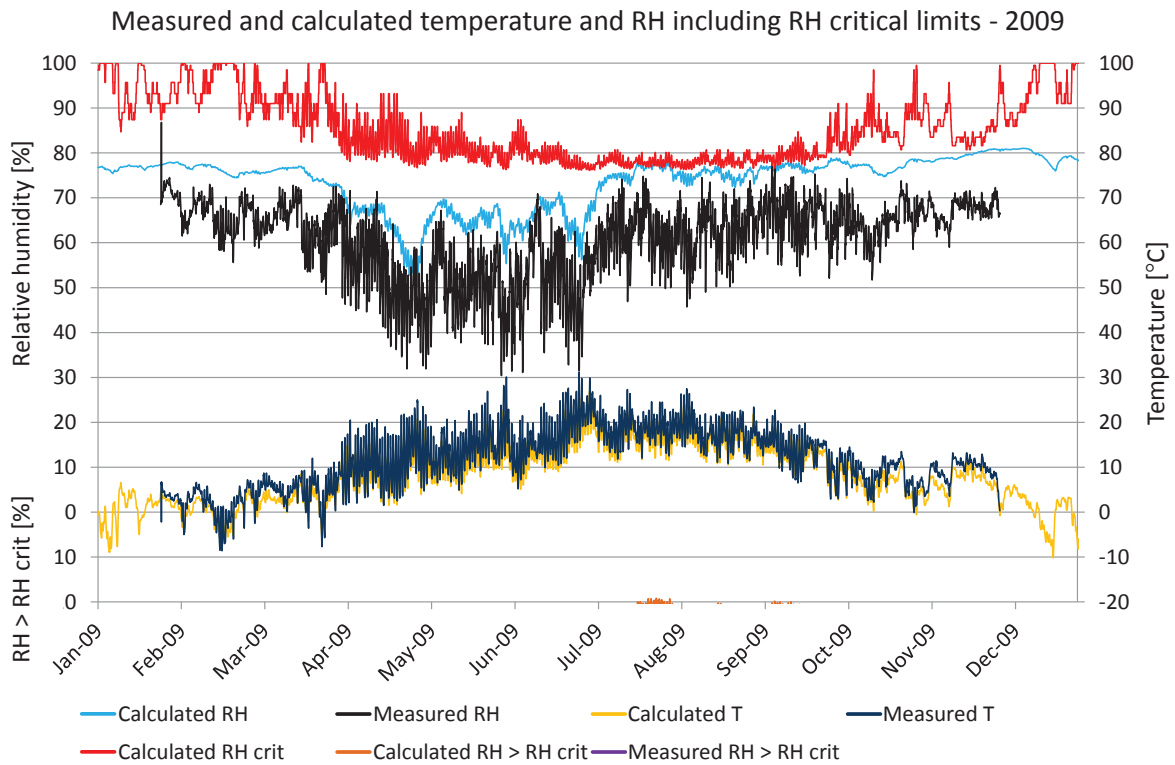

Figure 7.1.6. Comparisons between measured and calculated temperature and relative humidity. Calculated temperature (yellow), measured temperature (dark blue), calculated RH (turquoise), measured RH (black),  $RH_{crit}$  for calculated values (red), calculated  $RH > RH_{crit}$  (light brown), measured  $RH > RH_{crit}$  (purple).

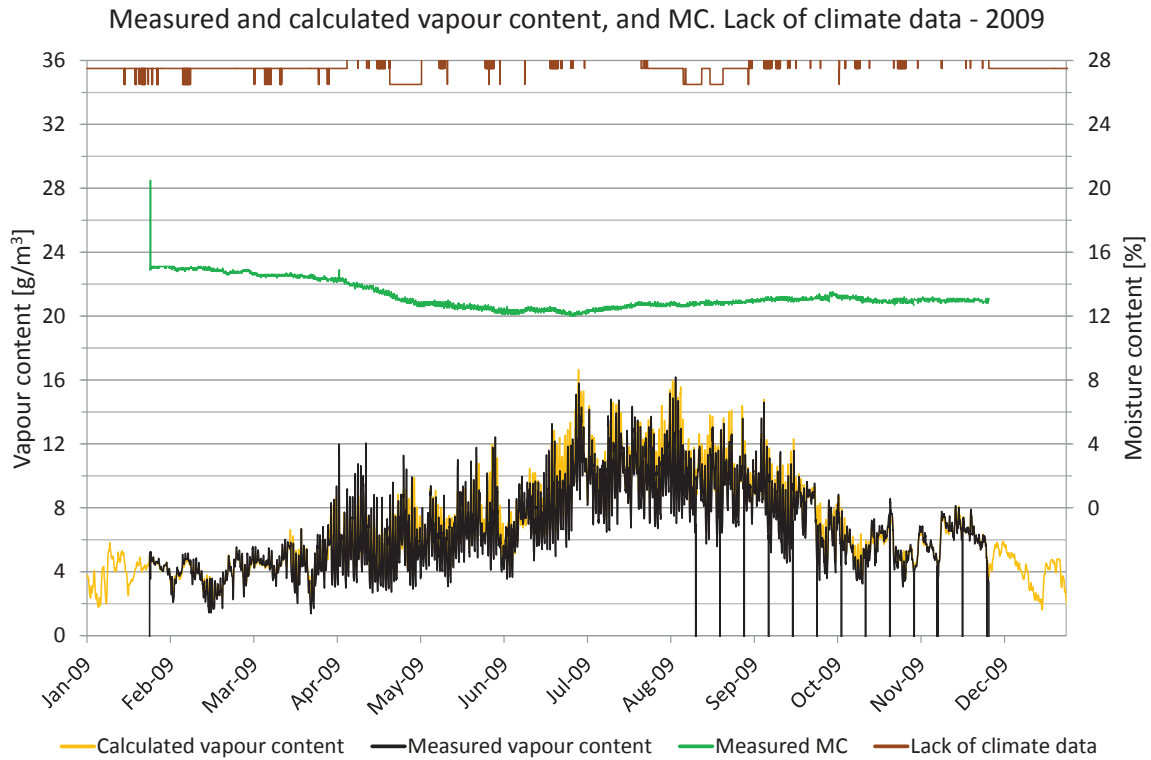

Figure 7.1.7. Measured moisture content, periods lacking climate data and comparisons of vapour content. Vapour content for calculated values (yellow) and measured values (black). Moisture content (green), periods with lack of climate data (brown).

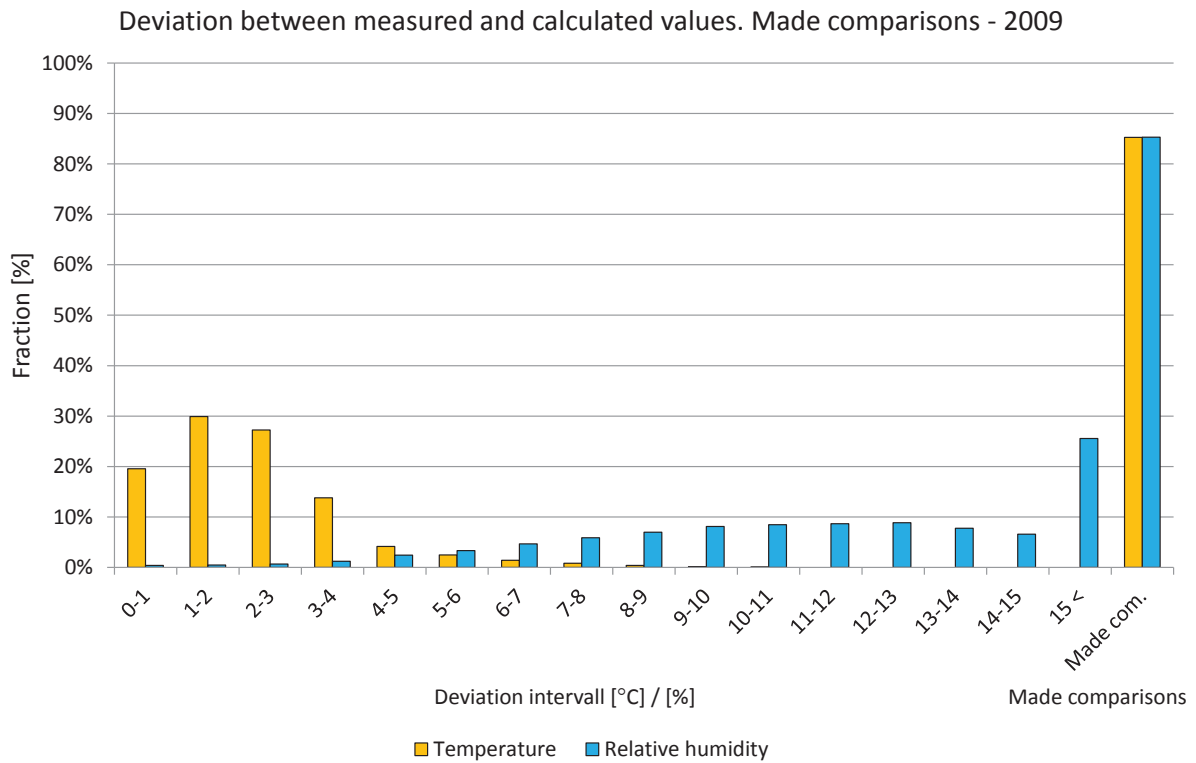

Figure 7.1.8. Deviations in comparisons shown in intervals from 0 to 15 °C or %. The two right-hand bars show the percentage of comparisons during the year. Temperature (yellow) and relative humidity (light blue).

**Year 2010**

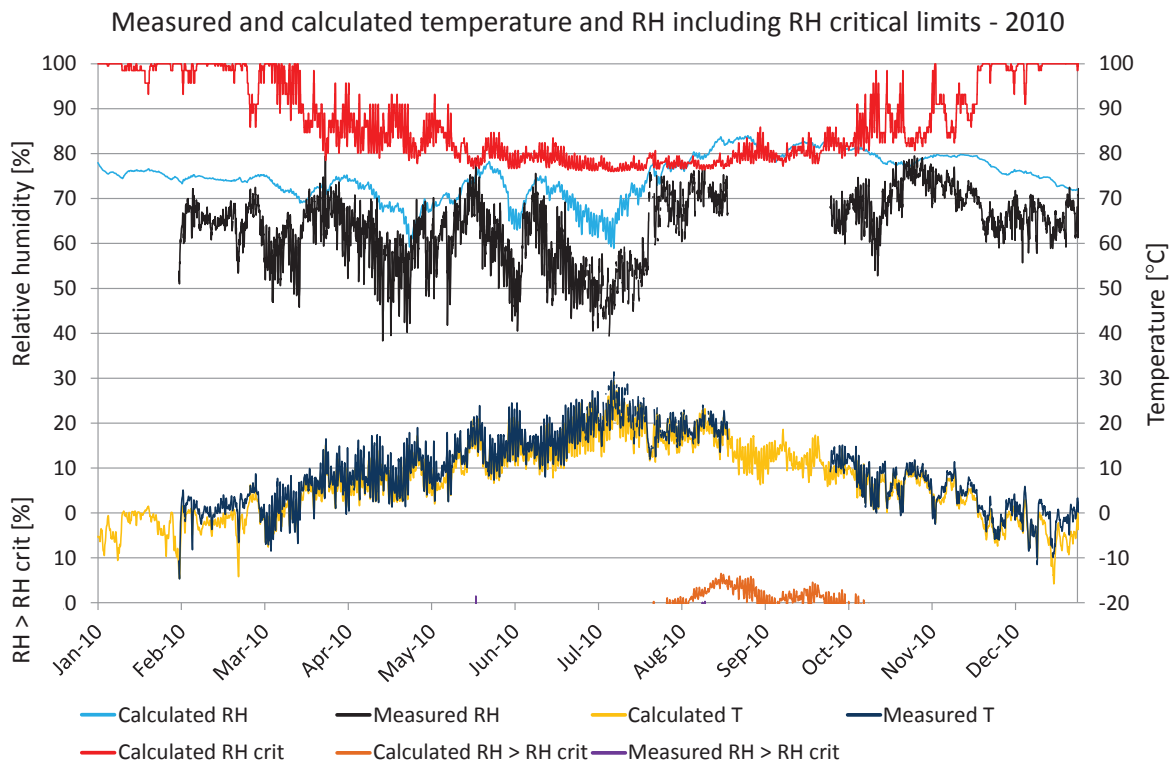

Figure 7.1.9. Comparisons between measured and calculated temperature and relative humidity. Calculated temperature (yellow), measured temperature (dark blue), calculated RH (turquoise), measured RH (black),  $RH_{crit}$  for calculated values (red), calculated  $RH > RH_{crit}$  (light brown), measured  $RH > RH_{crit}$  (purple).

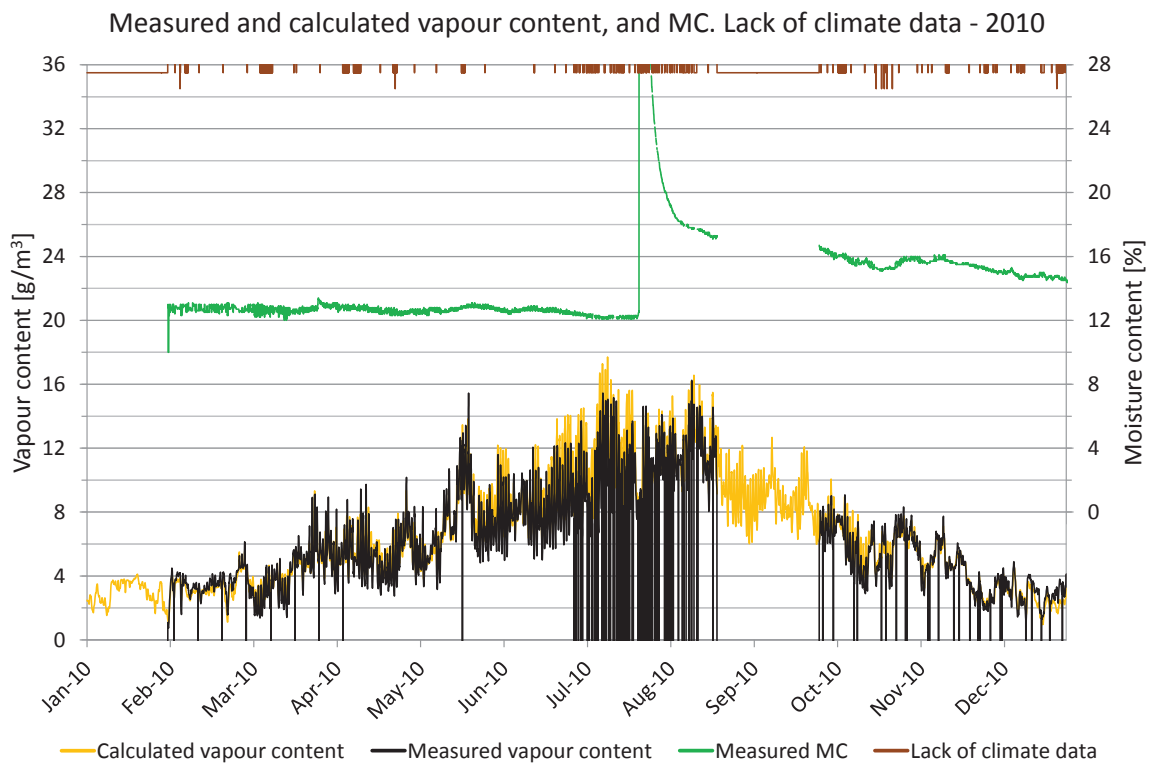

Figure 7.1.10. Measured moisture content, periods lacking climate data and comparisons of vapour content. Vapour content for calculated values (yellow) and measured values (black). Moisture content (green), periods with lack of climate data (brown).

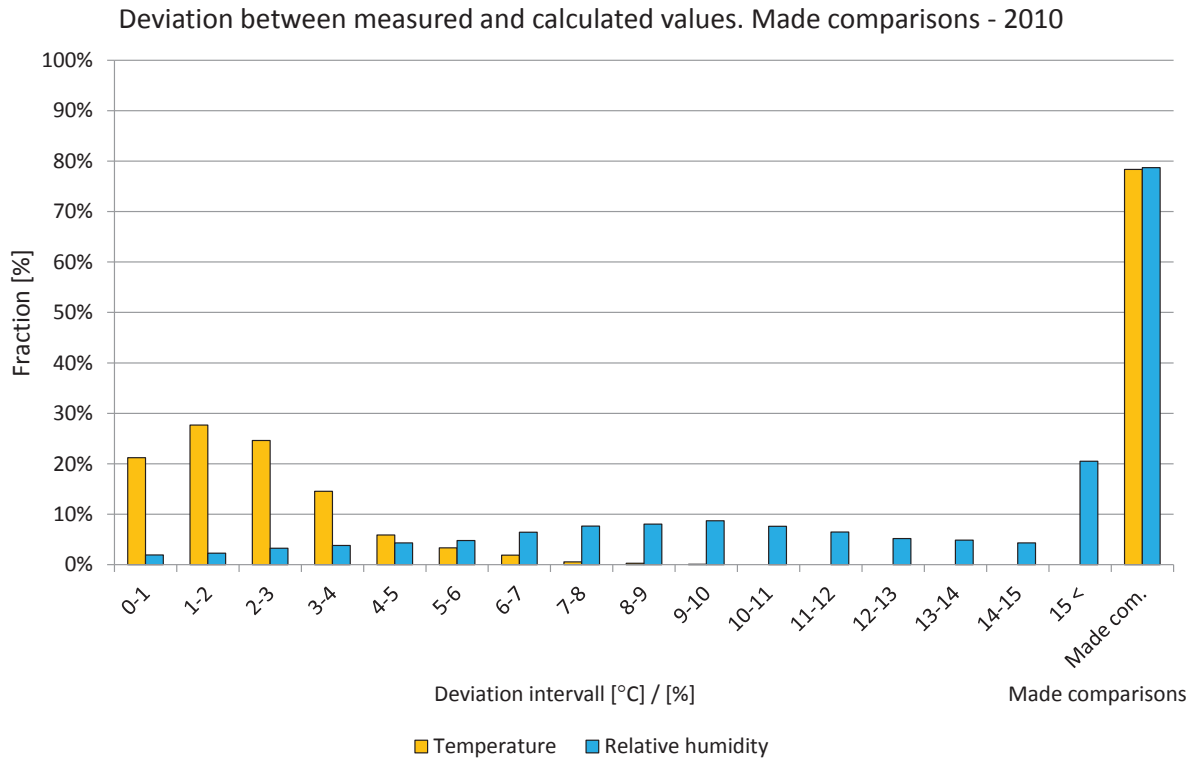

Figure 7.1.11. Deviations in comparisons shown in intervals from 0 to 15 °C or %. The two right-hand bars show the percentage of comparisons during the year. Temperature (yellow) and relative humidity (light blue).

**Year 2011**

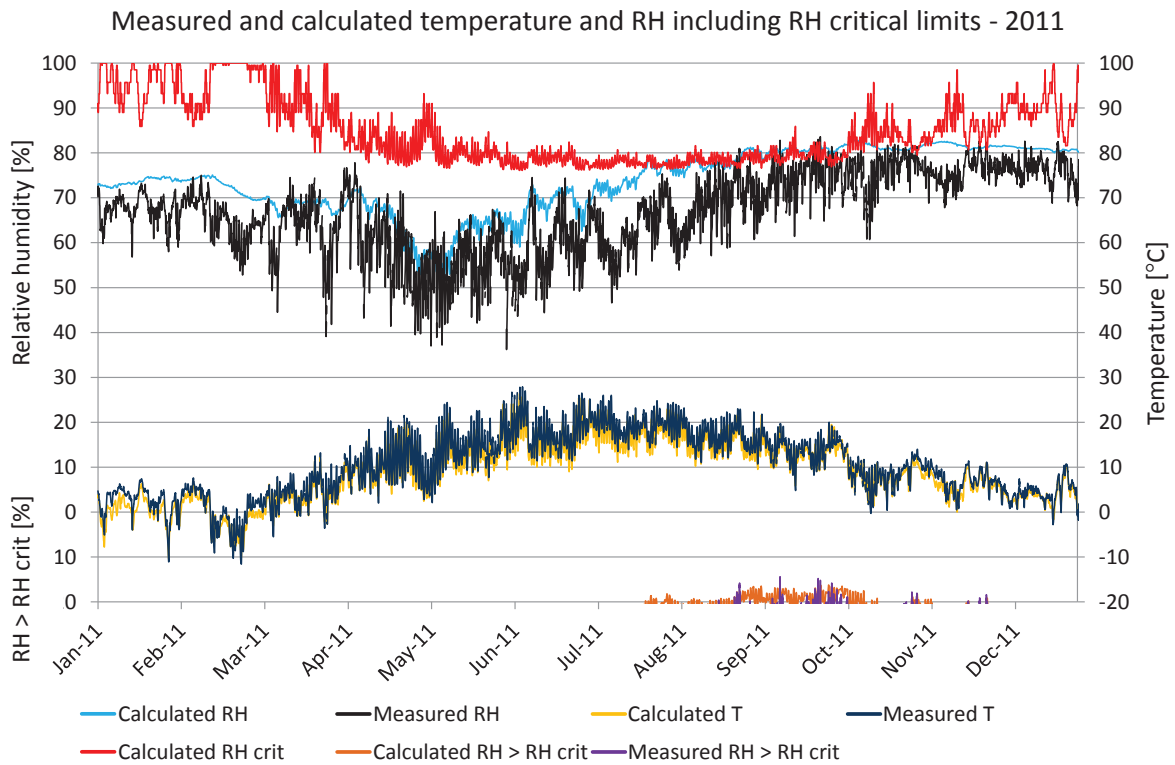

Figure 7.1.12. Comparisons between measured and calculated temperature and relative humidity. Calculated temperature (yellow), measured temperature (dark blue), calculated RH (turquoise), measured RH (black),  $RH_{crit}$  for calculated values (red), calculated  $RH > RH_{crit}$  (light brown), measured  $RH > RH_{crit}$  (purple).

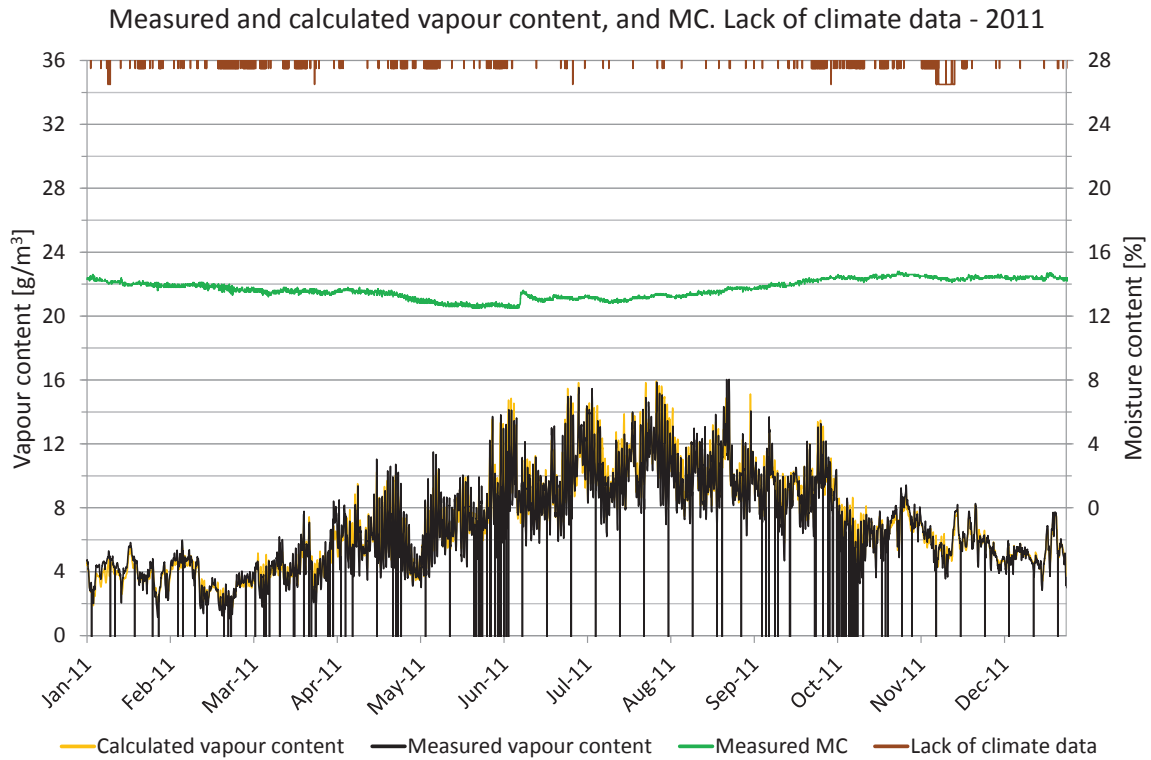

Figure 7.1.13. Measured moisture content, periods lacking climate data and comparisons of vapour content. Vapour content for calculated values (yellow) and measured values (black). Moisture content (green), periods with lack of climate data (brown).

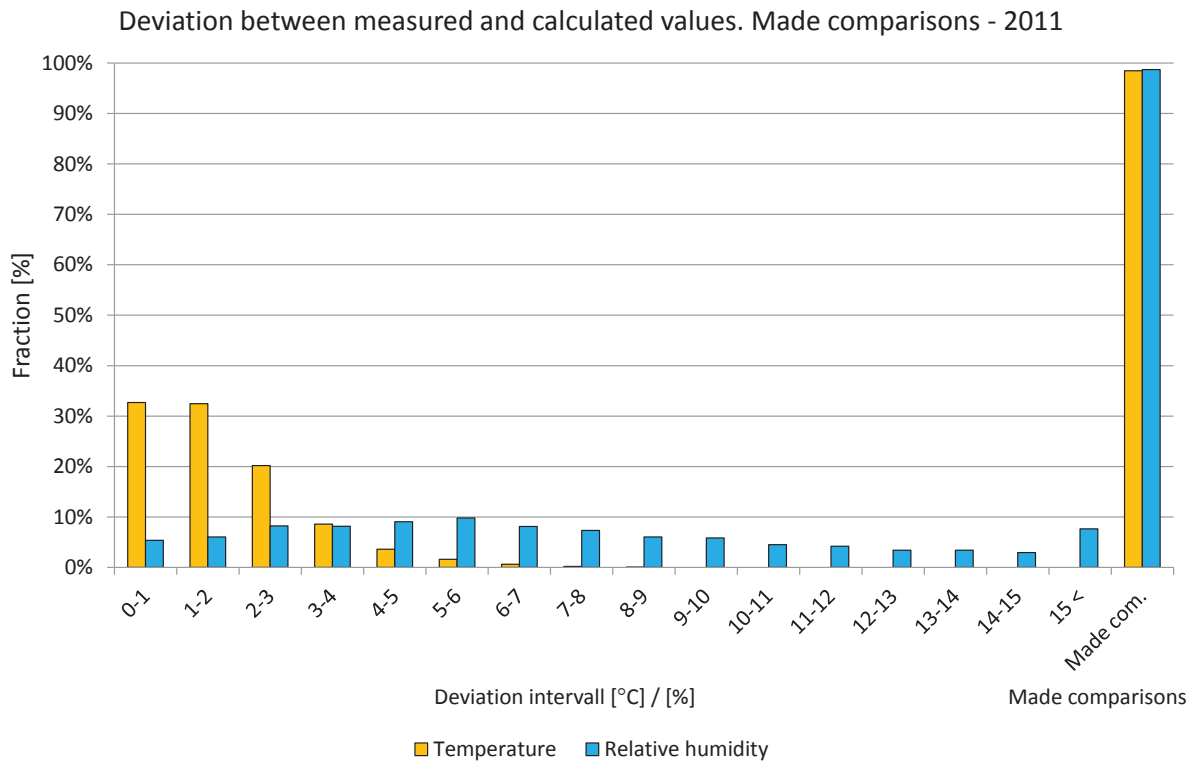

Figure 7.1.14. Deviations in comparisons shown in intervals from 0 to 15 °C or %. The two right-hand bars show the percentage of comparisons during the year. Temperature (yellow) and relative humidity (light blue).





## 7.2 Position 2

The locations of the measured and calculated position are shown in the drawings and figures below. The studied position is located in a wall facing northwest on the first floor.

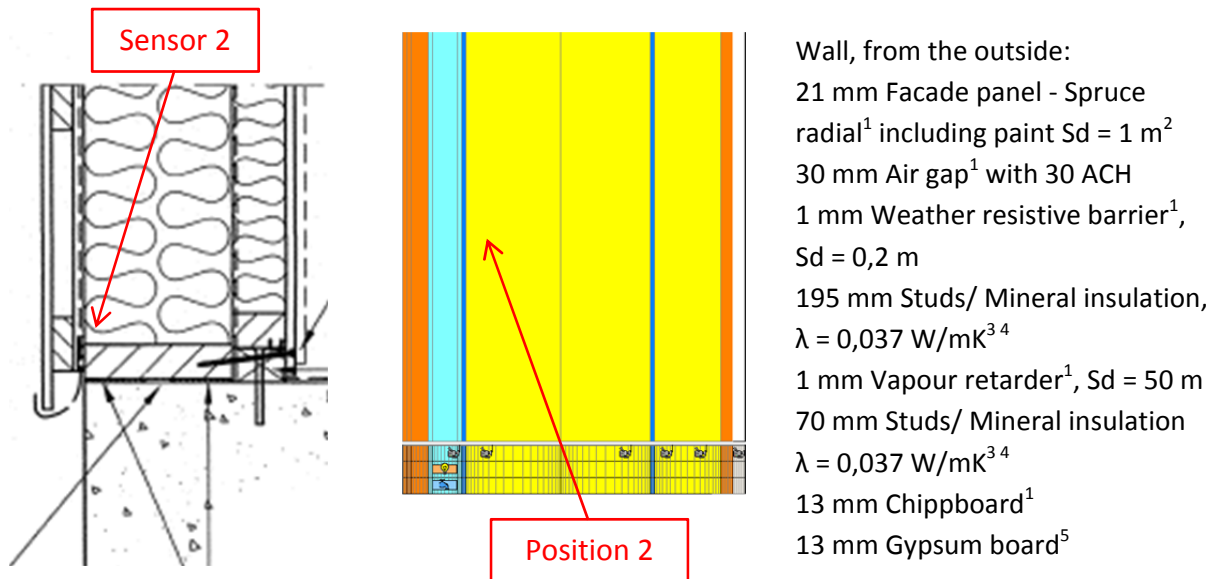

Figure 7.2.1. Vertical cross sectional drawing and WUFI calculation model showing the studied position. 1. IBP, 2012, 2. Nevander, L-E., 1994, 3. IEA Annex 24, 1996, 4. Paroc, 2002, 5. Krus, M., 1996.

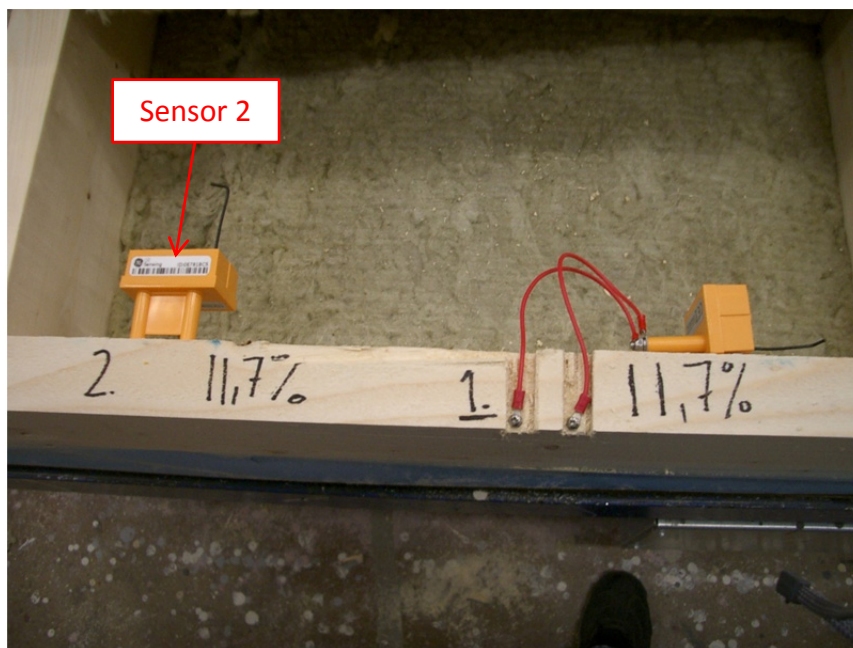

Figure 7.2.2. Location of the studied position. Photo: Götenehus AB.

A perfect match between the measured and calculated values cannot be expected due to e.g. the influence of two- and three-dimensional effects and the accuracy of the sensors.

**Year 2008**

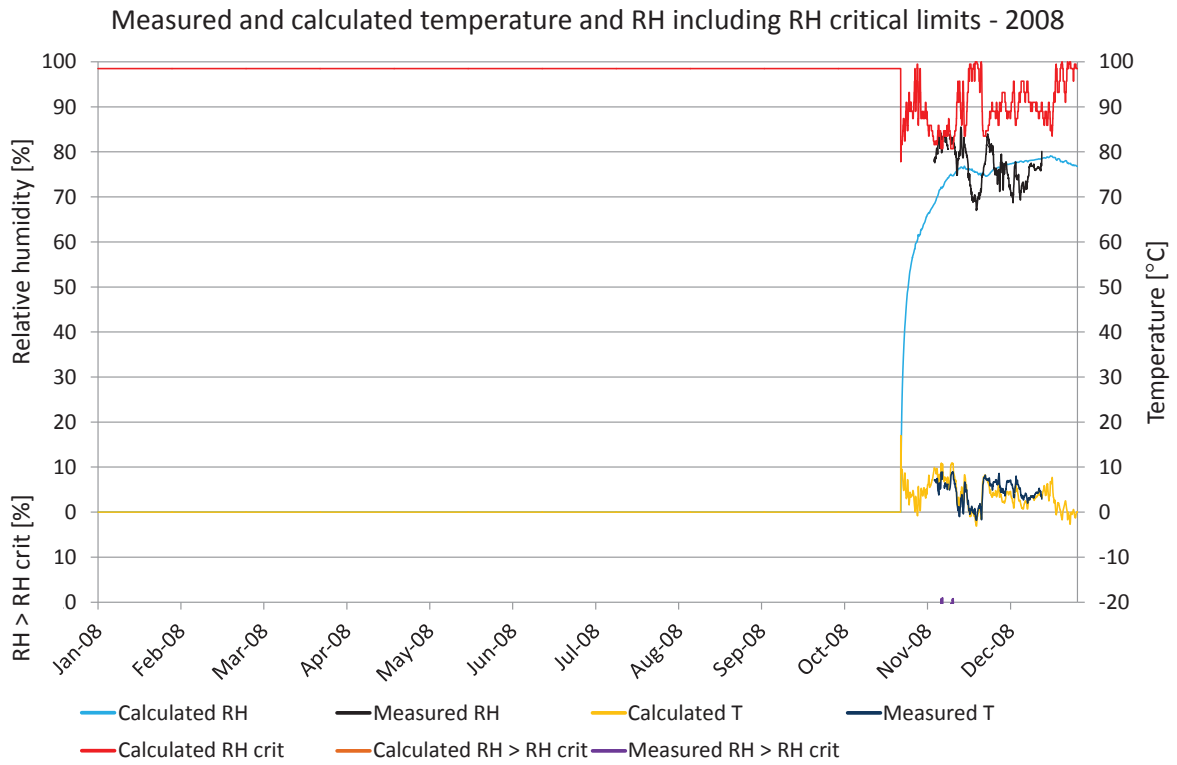

Figure 7.2.3. Comparisons between measured and calculated temperature and relative humidity. Calculated temperature (yellow), measured temperature (dark blue), calculated RH (turquoise), measured RH (black),  $RH_{crit}$  for calculated values (red), calculated  $RH > RH_{crit}$  (light brown), measured  $RH > RH_{crit}$  (purple).

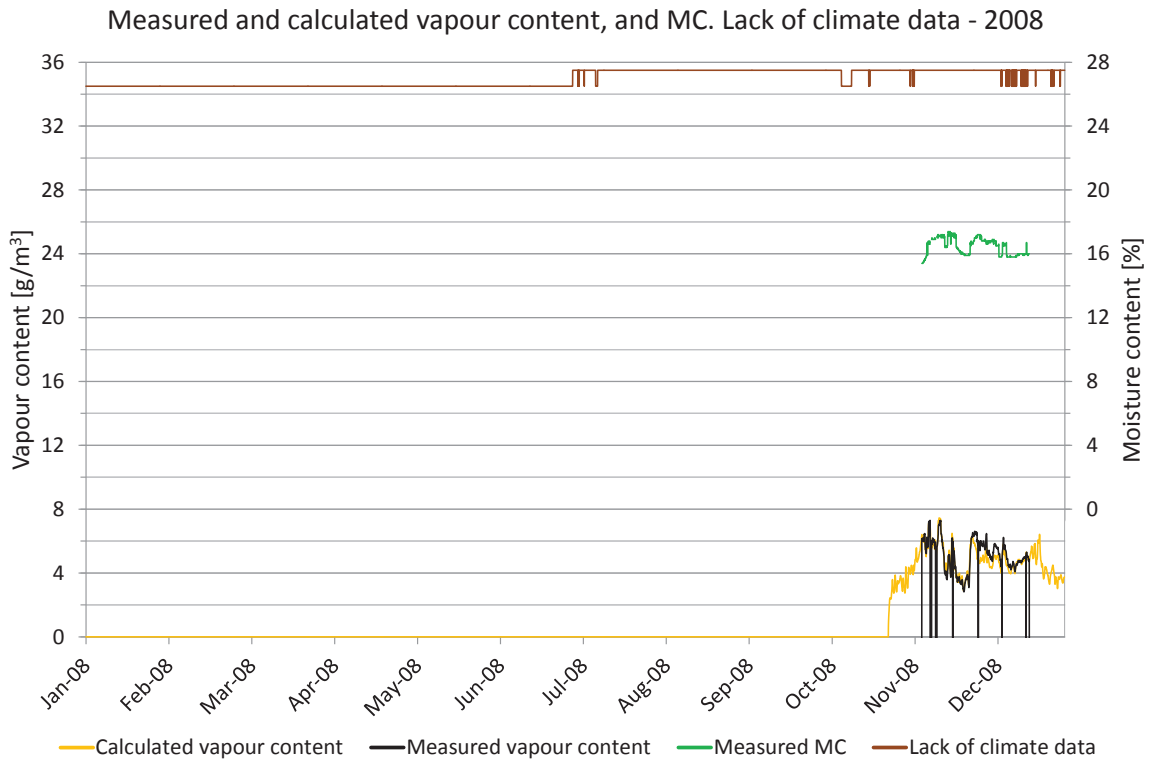

Figure 7.2.4. Measured moisture content, periods lacking climate data and comparisons of vapour content. Vapour content for calculated values (yellow) and measured values (black). Moisture content (green), periods with lack of climate data (brown).

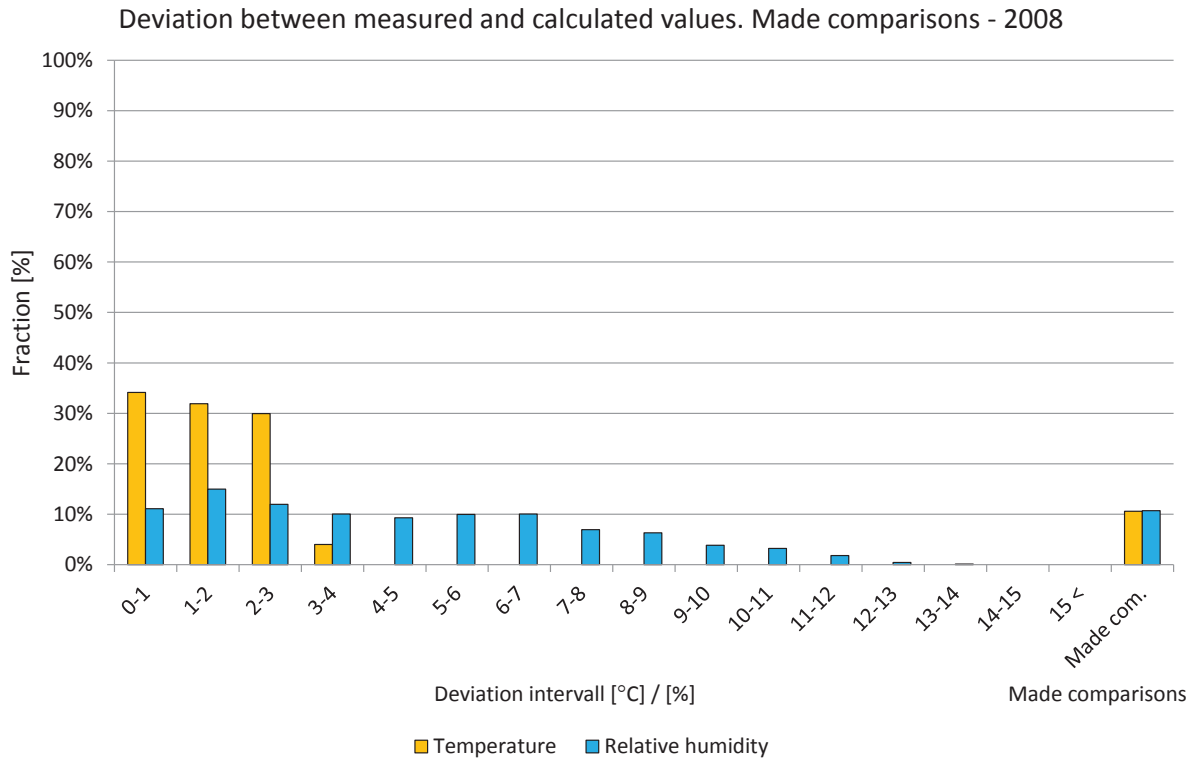

Figure 7.1.5. Deviations in comparisons shown in intervals from 0 to 15 °C or %. The two right-hand bars show the percentage of comparisons during the year. Temperature (yellow) and relative humidity (light blue).

### Year 2009

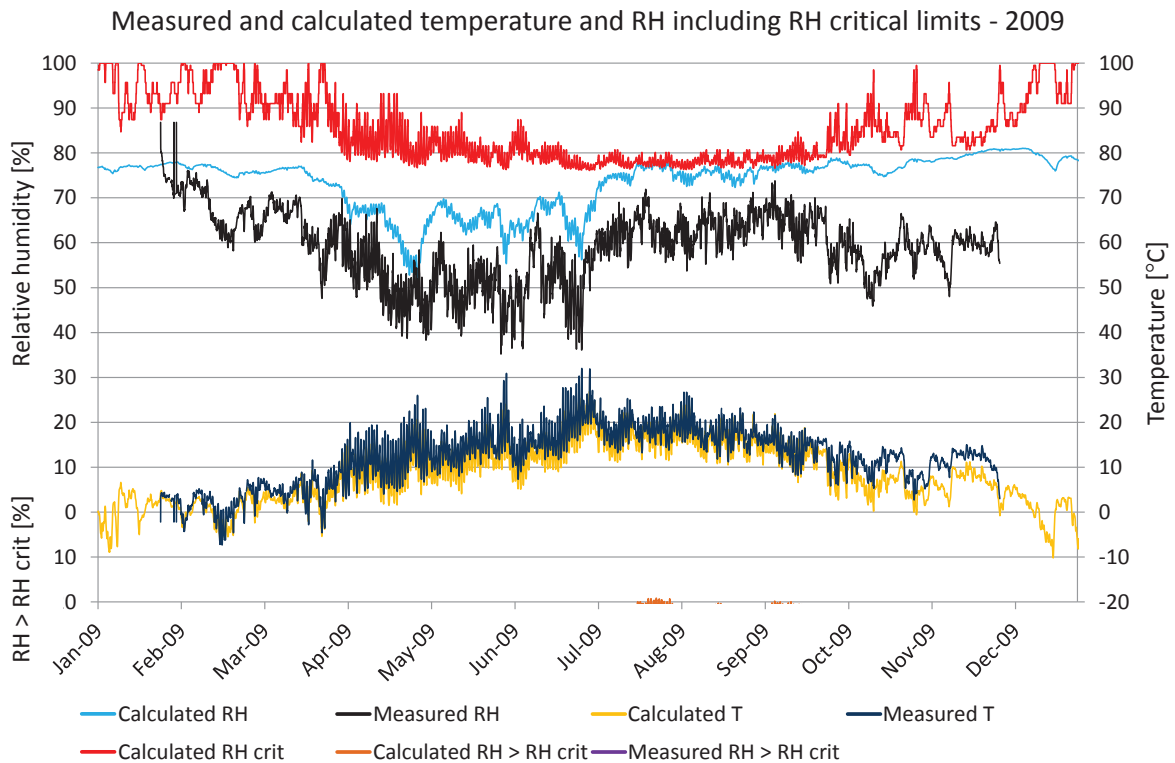

Figure 7.2.6. Comparisons between measured and calculated temperature and relative humidity. Calculated temperature (yellow), measured temperature (dark blue), calculated RH (turquoise), measured RH (black), RH<sub>crit</sub> for calculated values (red), calculated RH > RH<sub>crit</sub> (light brown), measured RH > RH<sub>crit</sub> (purple).

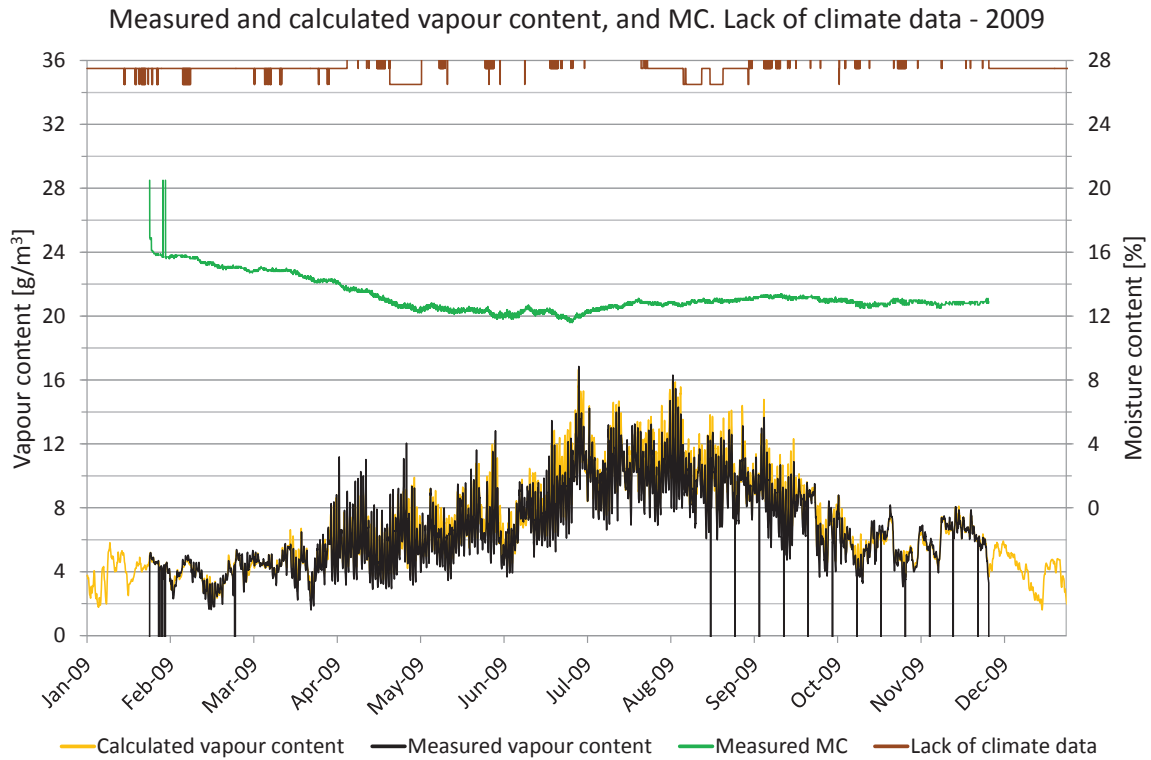

Figure 7.2.7. Measured moisture content, periods lacking climate data and comparisons of vapour content. Vapour content for calculated values (yellow) and measured values (black). Moisture content (green), periods with lack of climate data (brown).

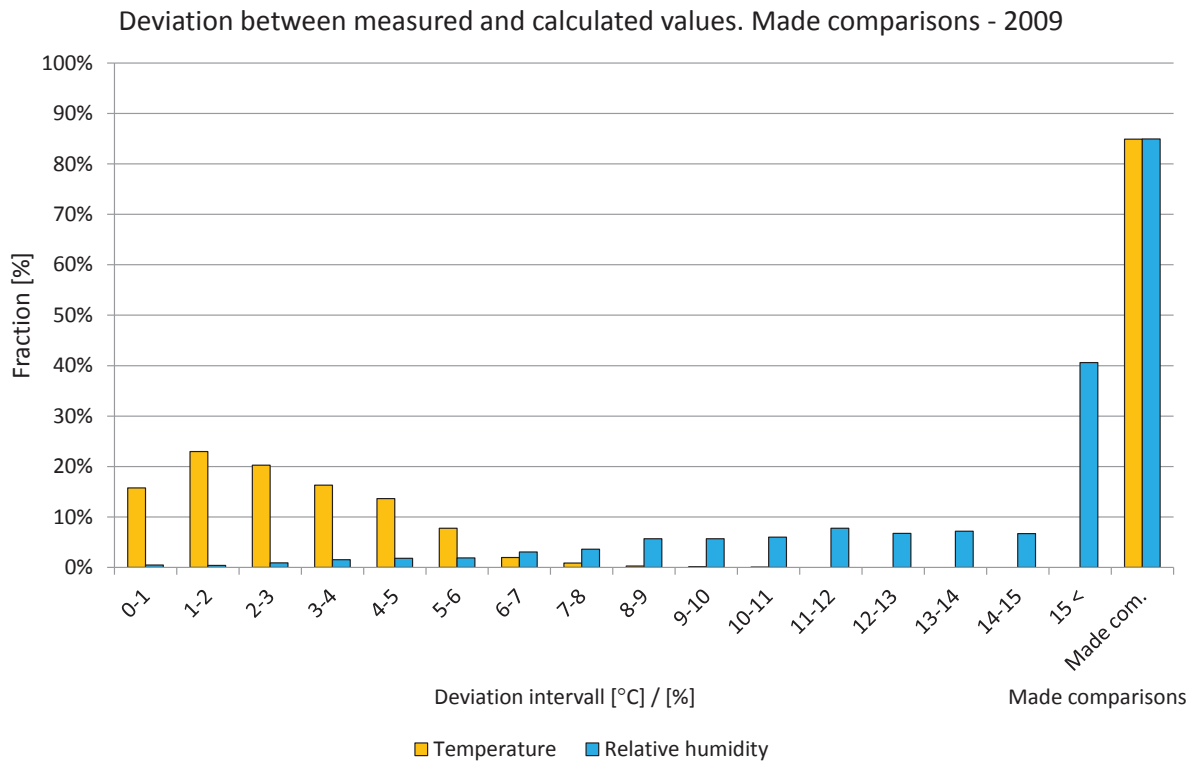

Figure 7.2.8. Deviations in comparisons shown in intervals from 0 to 15 °C or %. The two right-hand bars show the percentage of comparisons during the year. Temperature (yellow) and relative humidity (light blue).

**Year 2010**

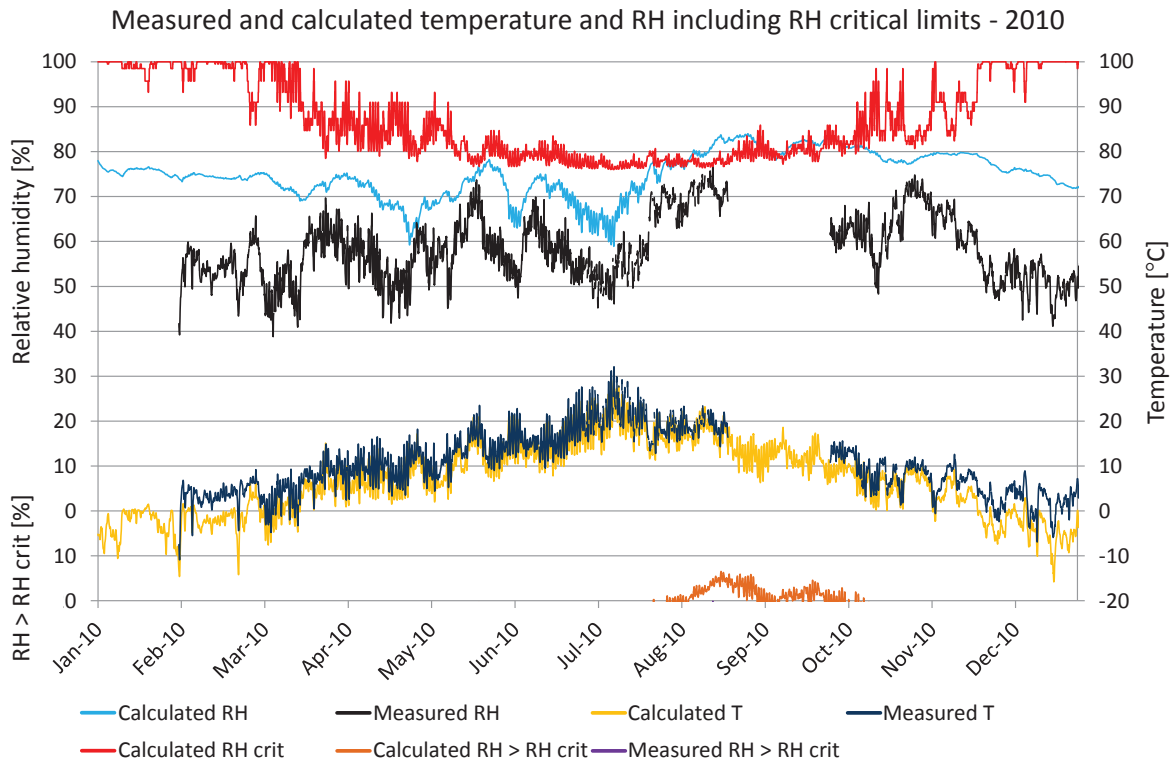

Figure 7.2.9. Comparisons between measured and calculated temperature and relative humidity. Calculated temperature (yellow), measured temperature (dark blue), calculated RH (turquoise), measured RH (black),  $RH_{crit}$  for calculated values (red), calculated  $RH > RH_{crit}$  (light brown), measured  $RH > RH_{crit}$  (purple).

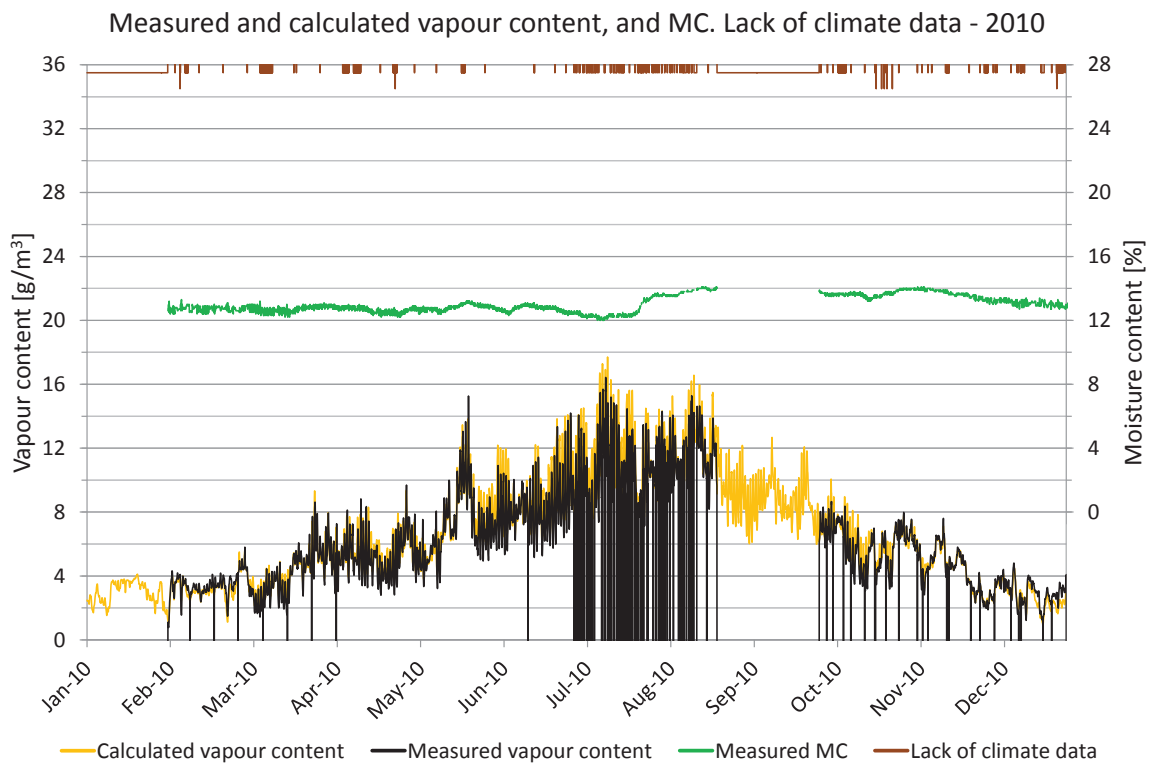

Figure 7.2.10. Measured moisture content, periods lacking climate data and comparisons of vapour content. Vapour content for calculated values (yellow) and measured values (black). Moisture content (green), periods with lack of climate data (brown).

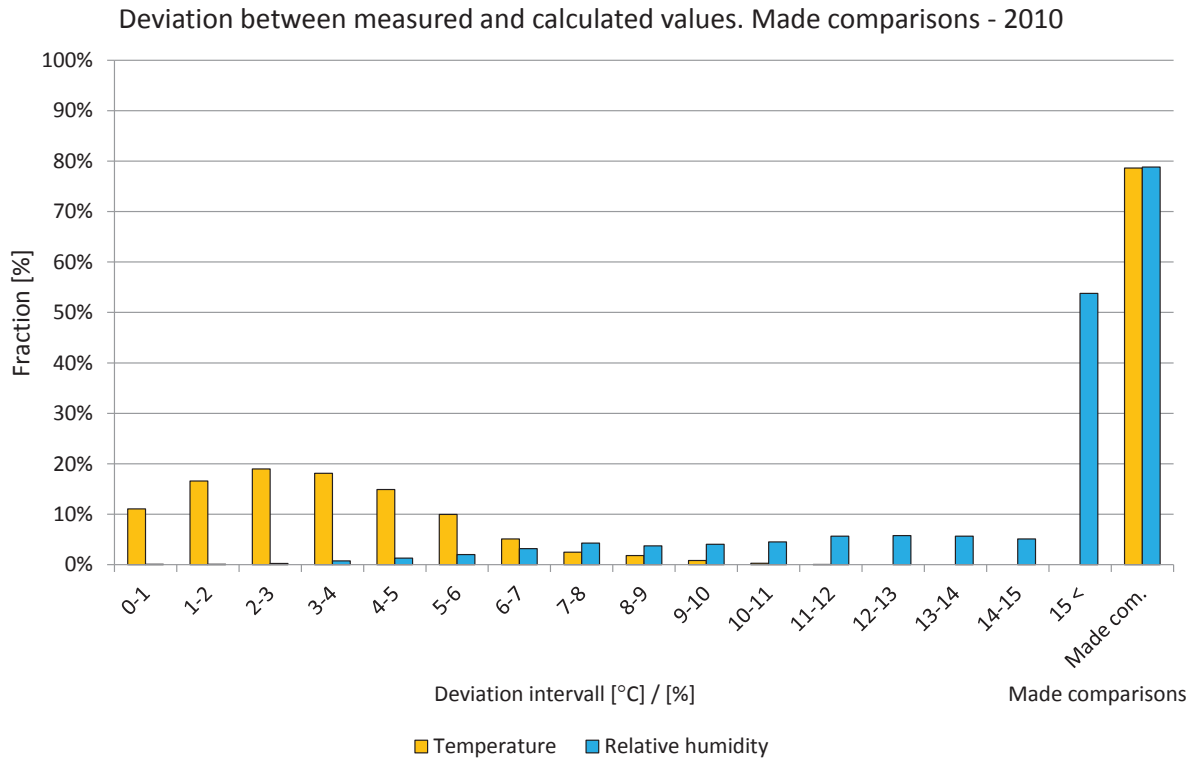

Figure 7.2.11. Deviations in comparisons shown in intervals from 0 to 15 °C or %. The two right-hand bars show the percentage of comparisons during the year. Temperature (yellow) and relative humidity (light blue).

### Year 2011

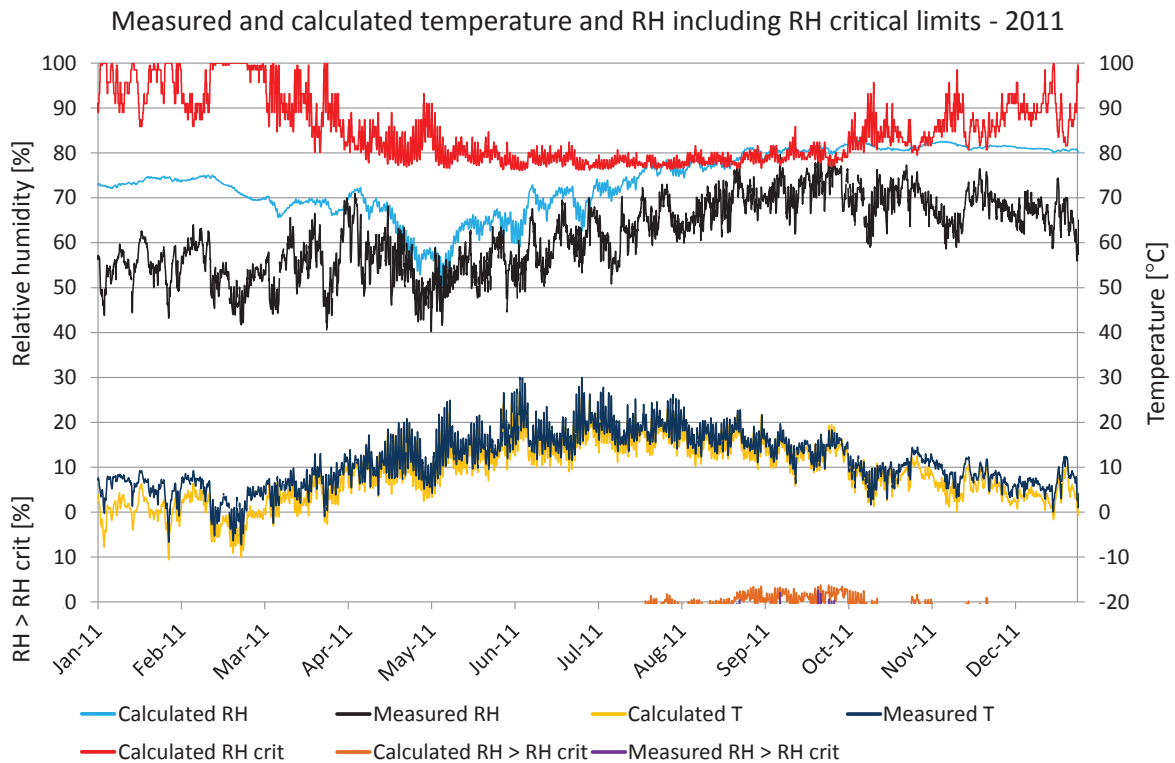

Figure 7.2.12. Comparisons between measured and calculated temperature and relative humidity. Calculated temperature (yellow), measured temperature (dark blue), calculated RH (turquoise), measured RH (black),  $RH_{crit}$  for calculated values (red), calculated  $RH > RH_{crit}$  (light brown), measured  $RH > RH_{crit}$  (purple).

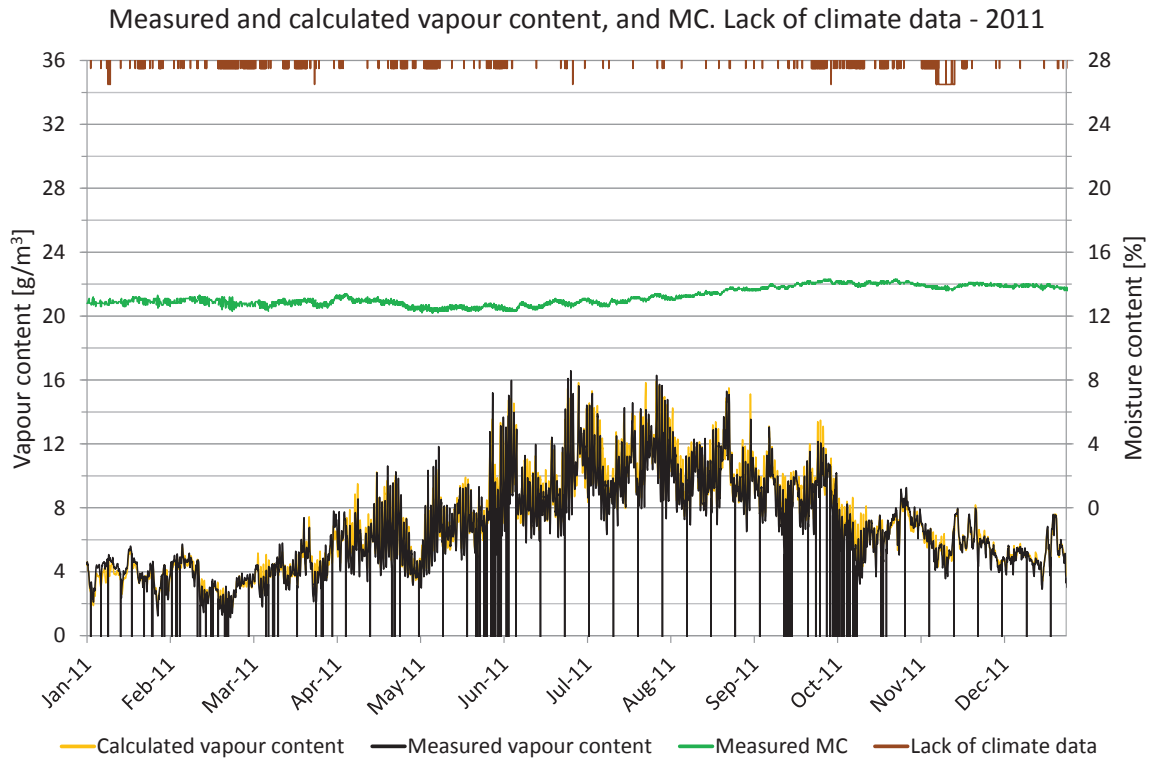

Figure 7.2.13. Measured moisture content, periods lacking climate data and comparisons of vapour content. Vapour content for calculated values (yellow) and measured values (black). Moisture content (green), periods with lack of climate data (brown).

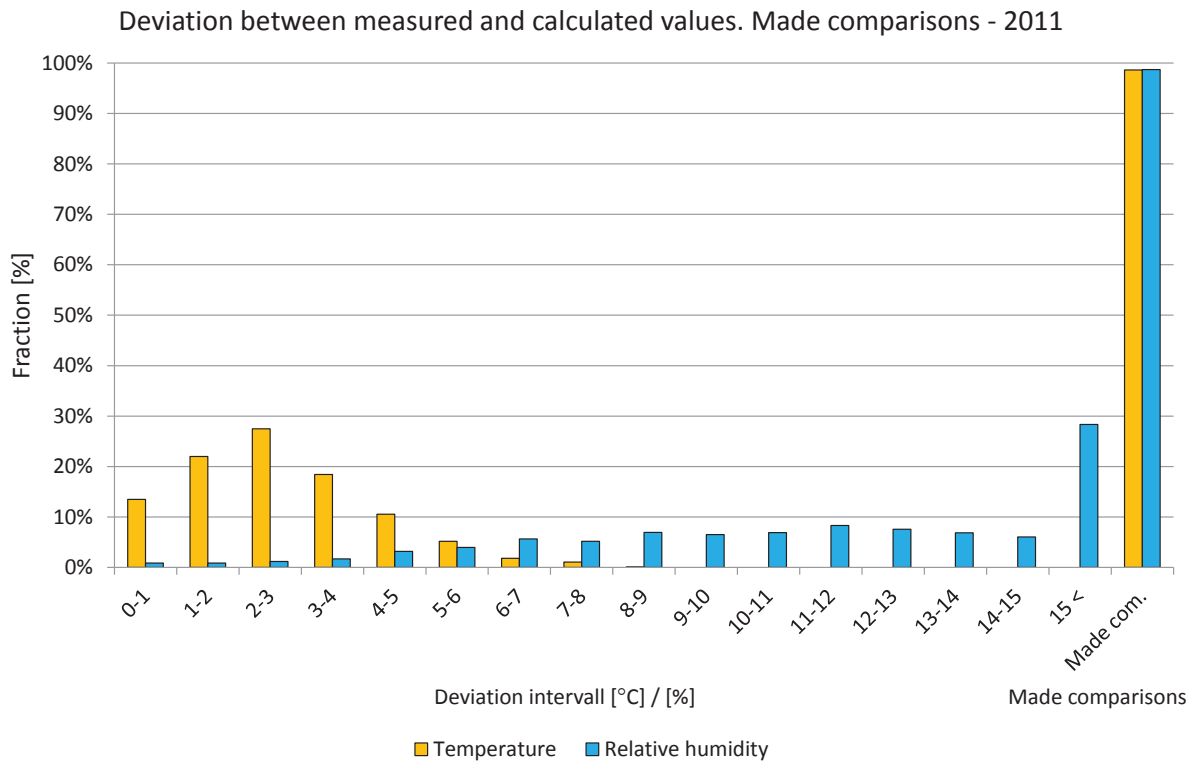

Figure 7.2.14. Deviations in comparisons shown in intervals from 0 to 15 °C or %. The two right-hand bars show the percentage of comparisons during the year. Temperature (yellow) and relative humidity (light blue).





### 7.3 Position 3

The locations of the measured and calculated position are shown in the drawings and figures below. The studied position is located in a wall facing northwest on the first floor.

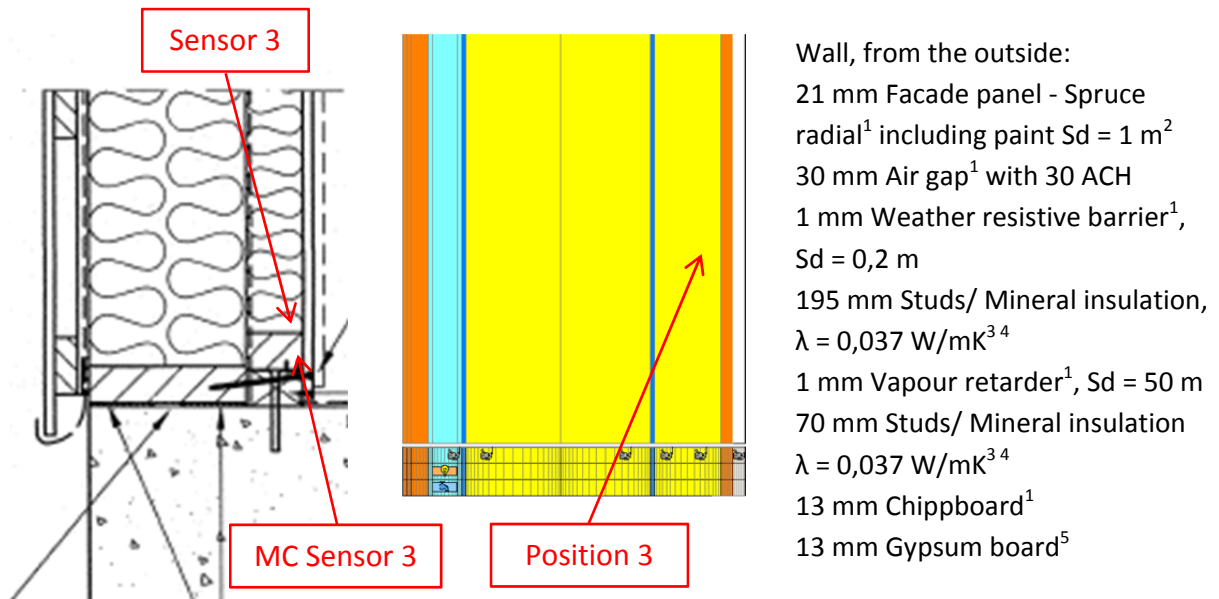

Figure 7.3.1. Vertical cross sectional drawing and WUFI calculation model showing the studied position. 1. IBP, 2012, 2. Nevander, L-E., 1994, 3. IEA Annex 24, 1996, 4. Paroc, 2002, 5. Krus, M., 1996.

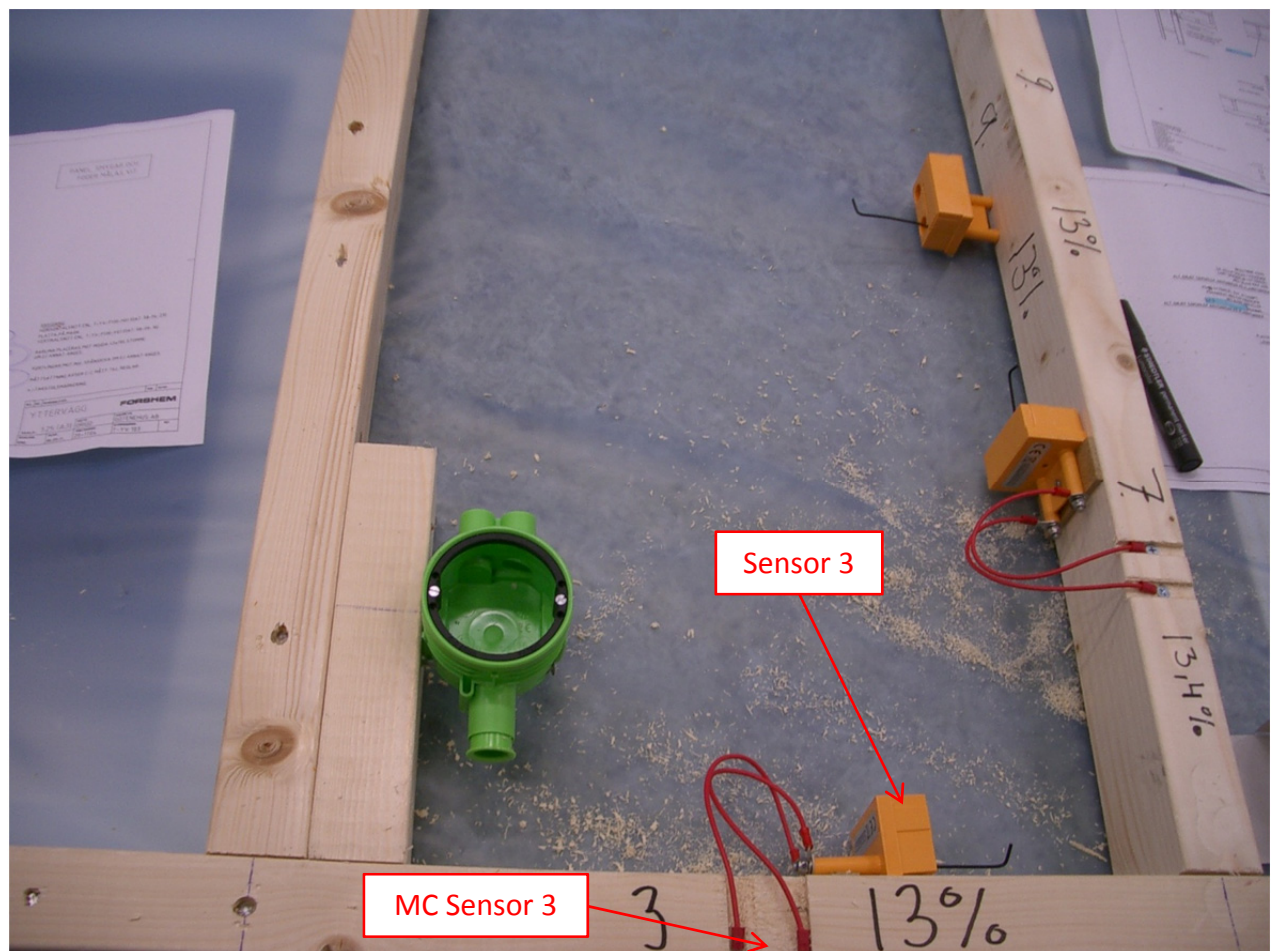

Figure 7.3.2. Location of the studied position. Photo: Götenehus AB.

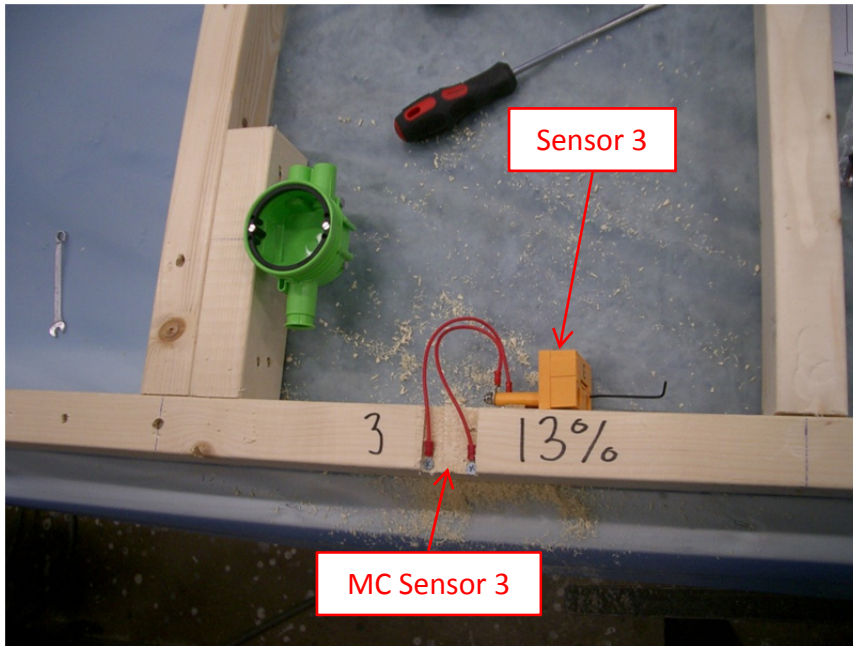

Figure 7.3.3. Location of the studied position.

A perfect match between the measured and calculated values cannot be expected due to e.g. the influence of two- and three-dimensional effects and the accuracy of the sensors.

### Year 2008

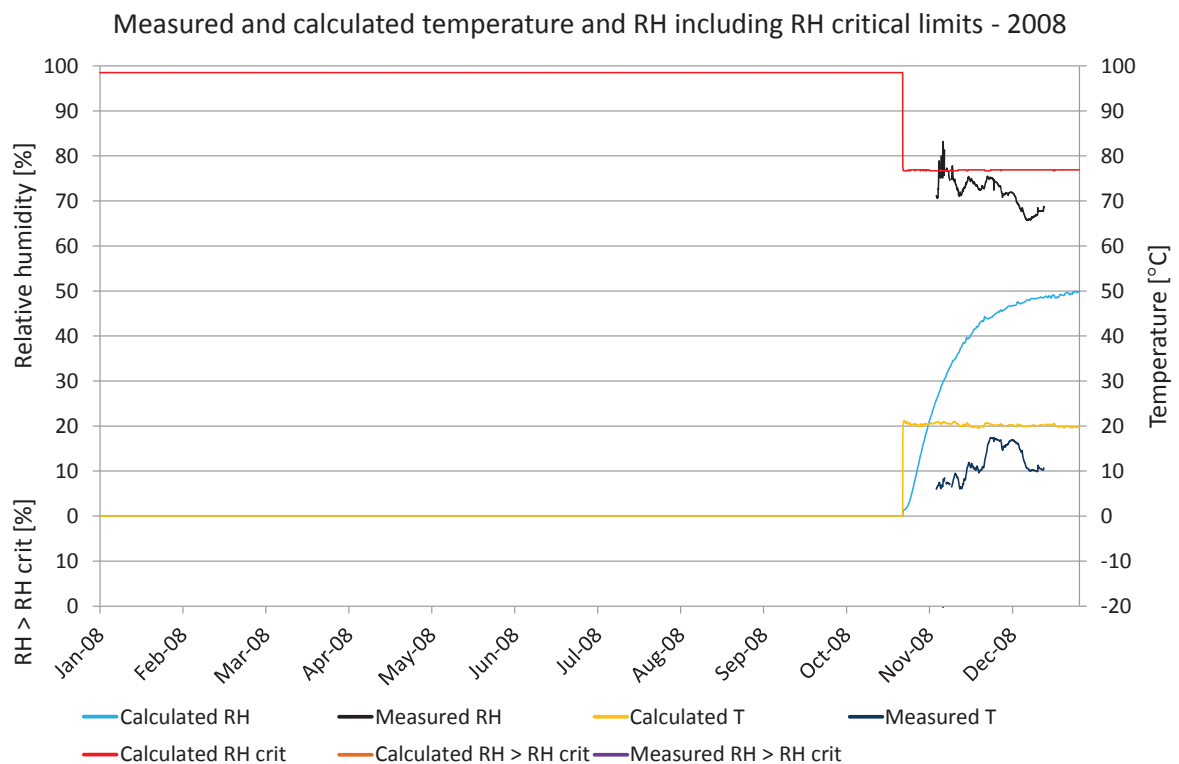

Figure 7.3.4. Comparisons between measured and calculated temperature and relative humidity. Calculated temperature (yellow), measured temperature (dark blue), calculated RH (turquoise), measured RH (black),  $RH_{crit}$  for calculated values (red), calculated  $RH > RH_{crit}$  (light brown), measured  $RH > RH_{crit}$  (purple).

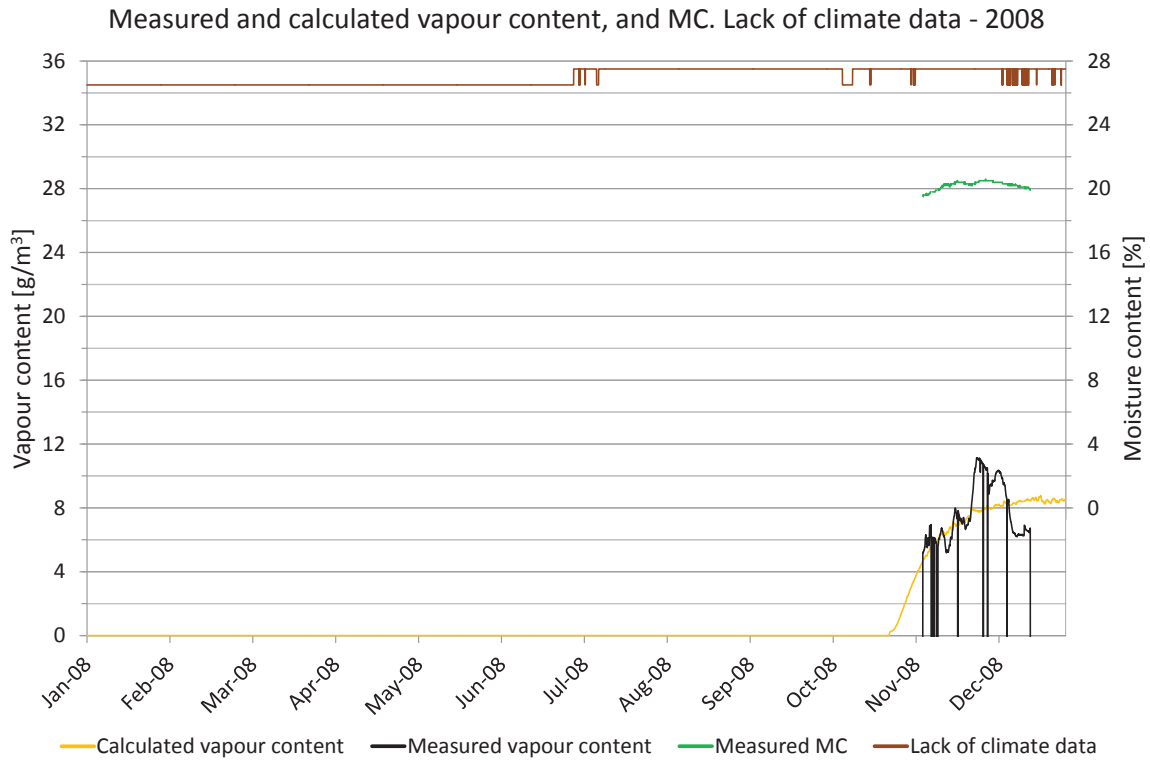

Figure 7.3.5. Measured moisture content, periods lacking climate data and comparisons of vapour content. Vapour content for calculated values (yellow) and measured values (black). Moisture content (green), periods with lack of climate data (brown).

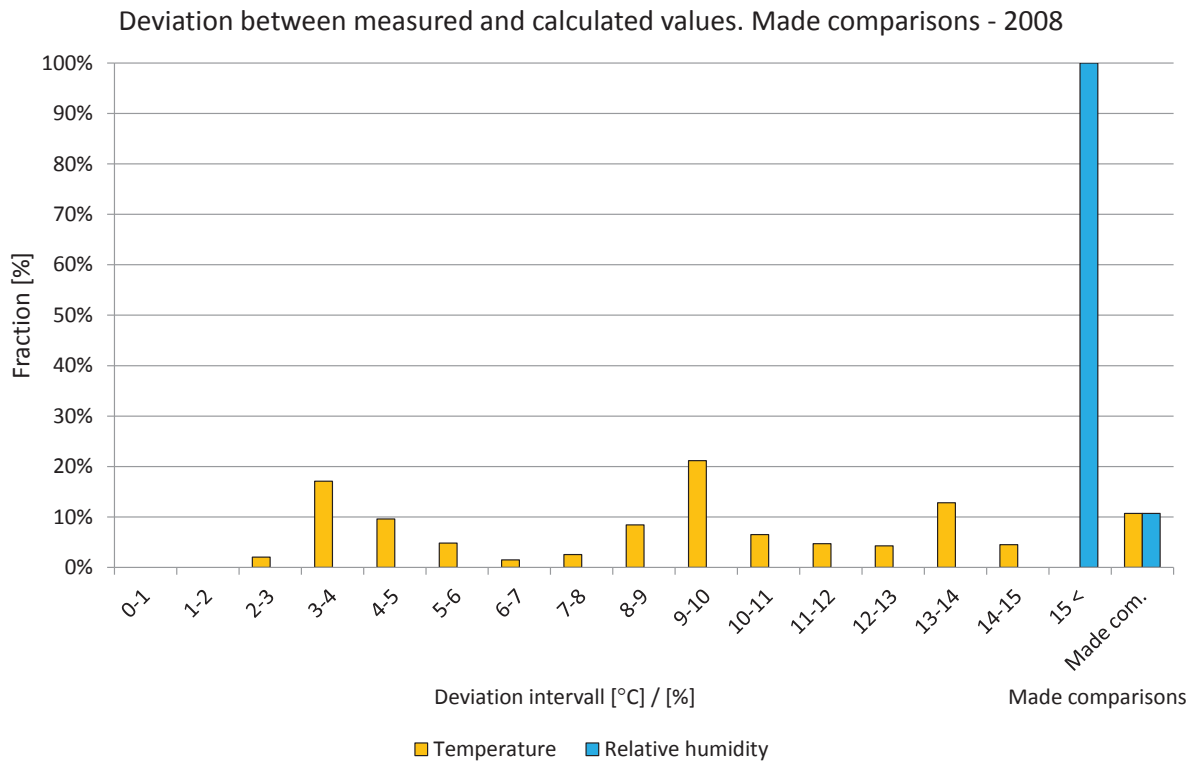

Figure 7.3.6. Deviations in comparisons shown in intervals from 0 to 15 °C or %. The two right-hand bars show the percentage of comparisons during the year. Temperature (yellow) and relative humidity (light blue).

**Year 2009**

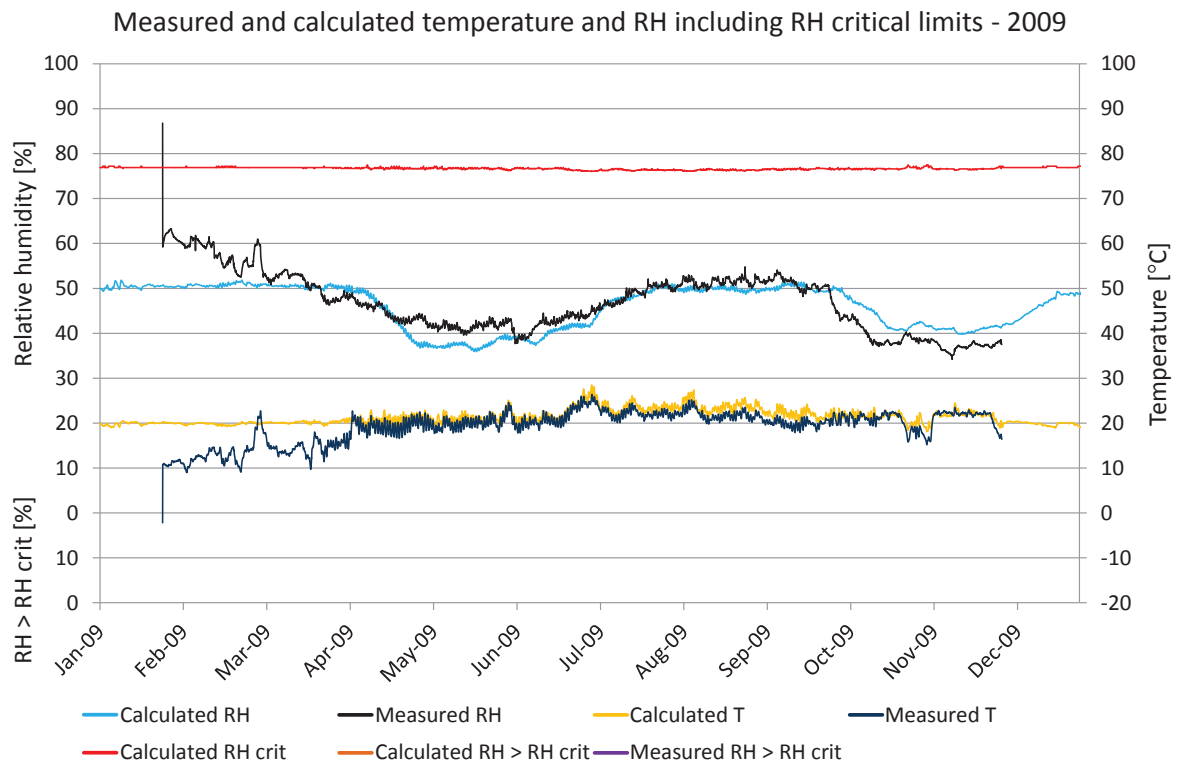

Figure 7.3.7. Comparisons between measured and calculated temperature and relative humidity. Calculated temperature (yellow), measured temperature (dark blue), calculated RH (turquoise), measured RH (black),  $RH_{crit}$  for calculated values (red), calculated  $RH > RH_{crit}$  (light brown), measured  $RH > RH_{crit}$  (purple).

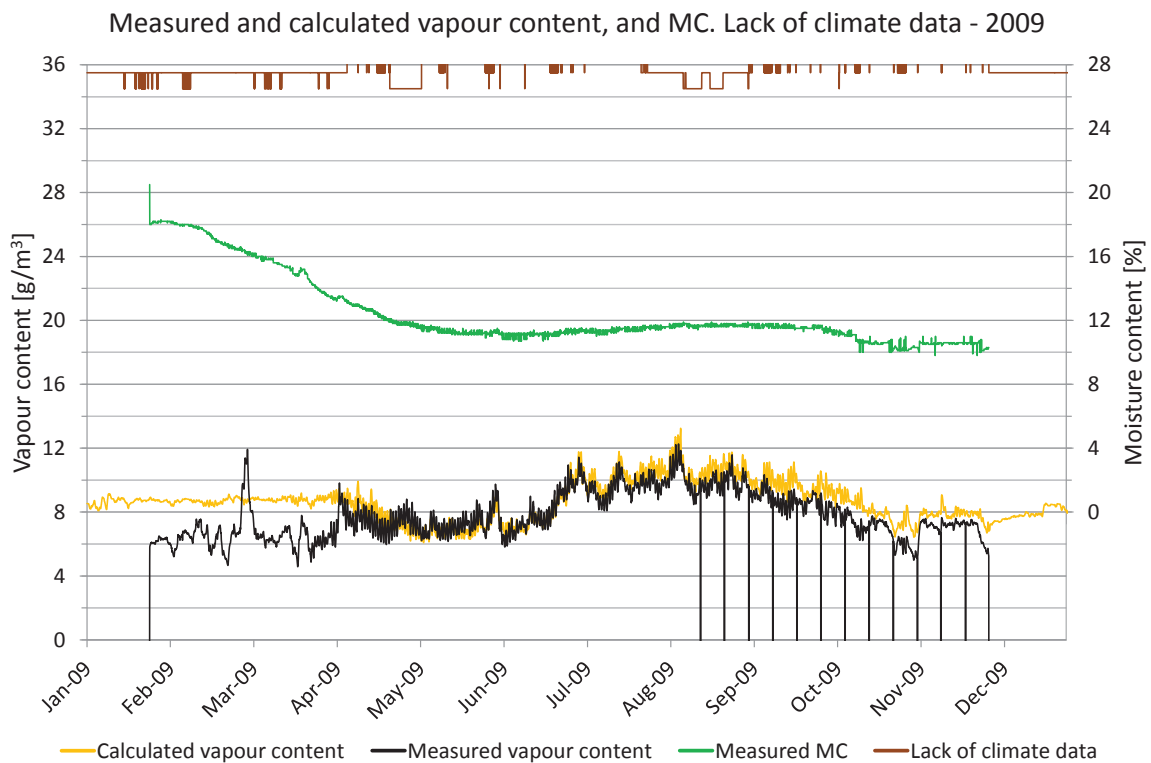

Figure 7.3.8. Measured moisture content, periods lacking climate data and comparisons of vapour content. Vapour content for calculated values (yellow) and measured values (black). Moisture content (green), periods with lack of climate data (brown).

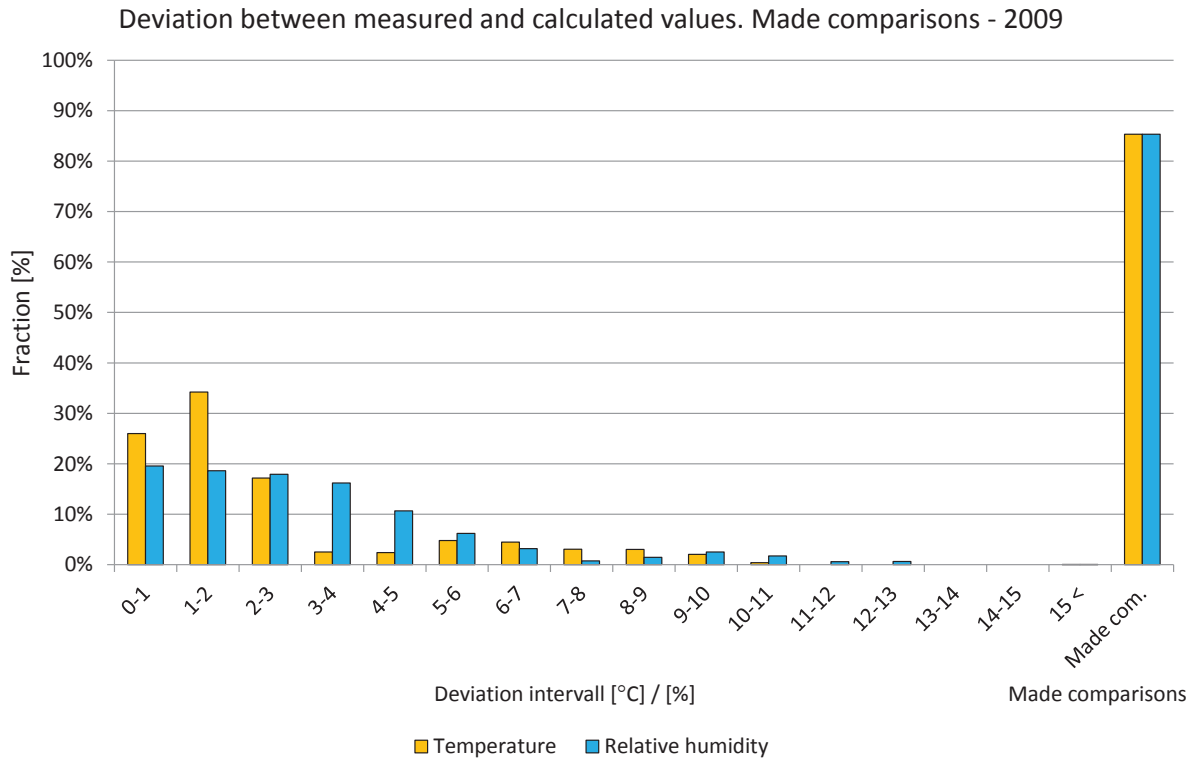

Figure 7.3.9. Deviations in comparisons shown in intervals from 0 to 15 °C or %. The two right-hand bars show the percentage of comparisons during the year. Temperature (yellow) and relative humidity (light blue).

### Year 2010

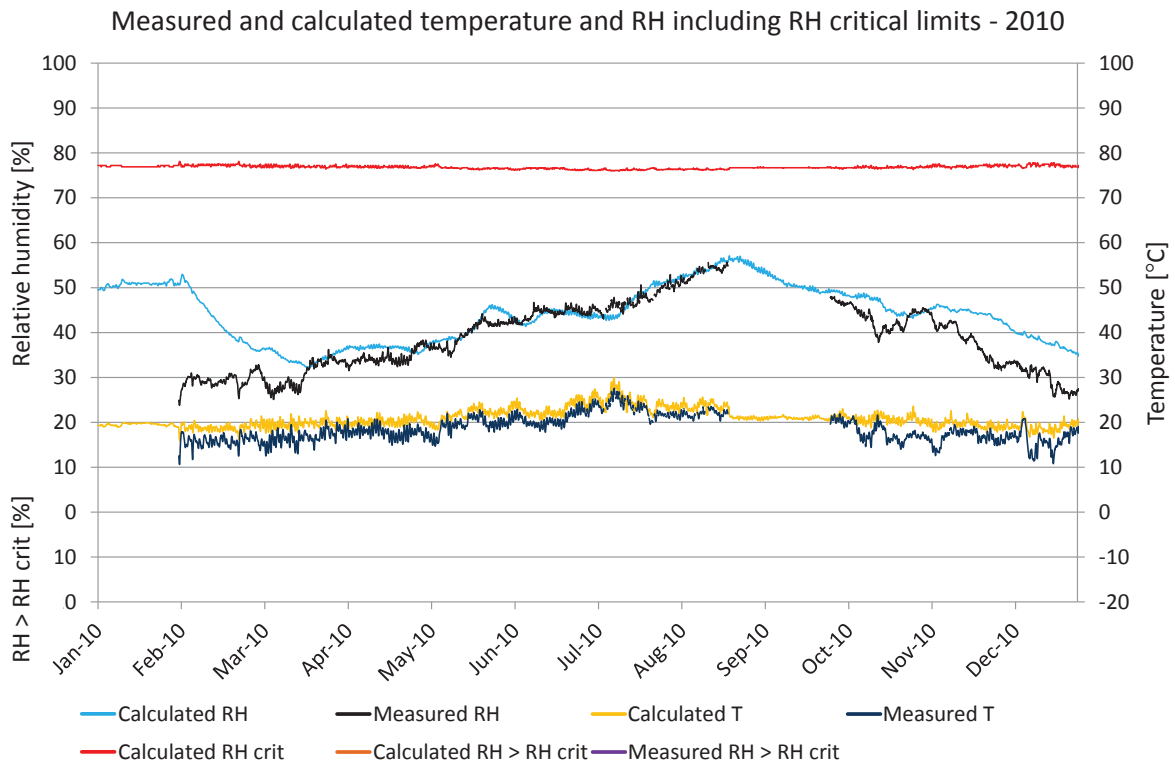

Figure 7.3.10. Comparisons between measured and calculated temperature and relative humidity. Calculated temperature (yellow), measured temperature (dark blue), calculated RH (turquoise), measured RH (black),  $RH_{crit}$  for calculated values (red), calculated  $RH > RH_{crit}$  (light brown), measured  $RH > RH_{crit}$  (purple).

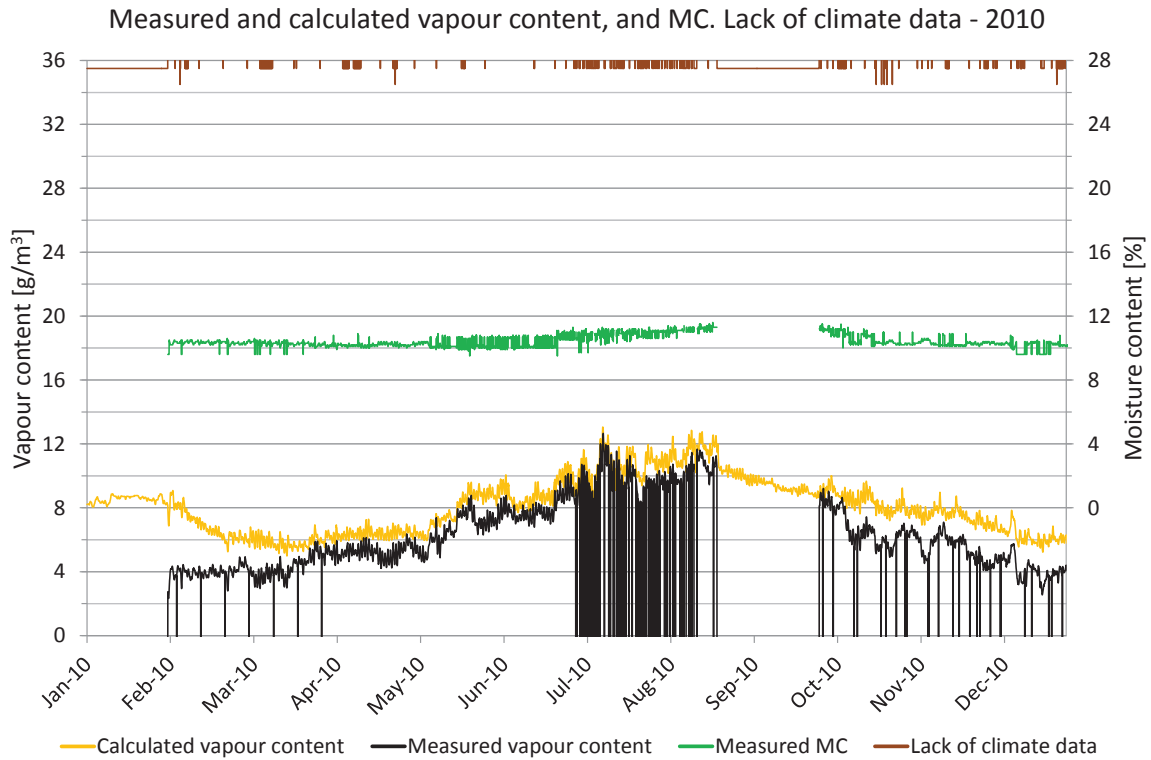

Figure 7.3.11. Measured moisture content, periods lacking climate data and comparisons of vapour content. Vapour content for calculated values (yellow) and measured values (black). Moisture content (green), periods with lack of climate data (brown).

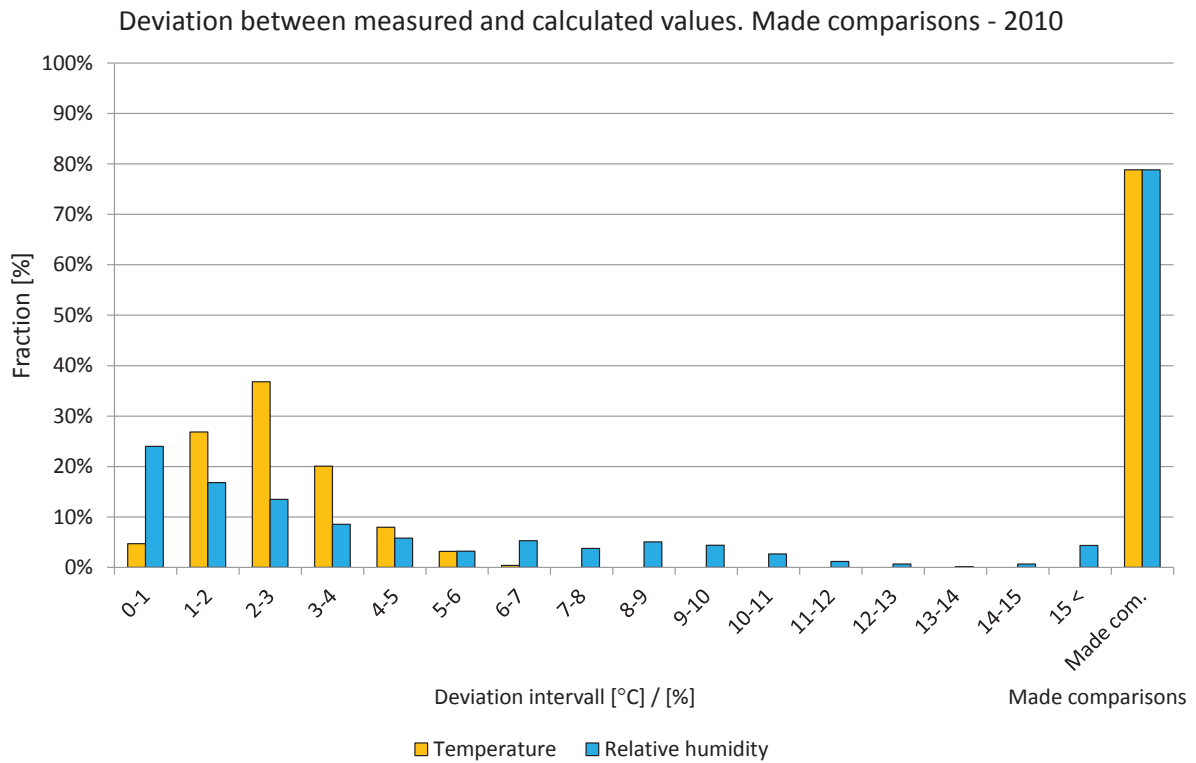

Figure 7.3.12. Deviations in comparisons shown in intervals from 0 to 15 °C or %. The two right-hand bars show the percentage of comparisons during the year. Temperature (yellow) and relative humidity (light blue).

**Year 2011**

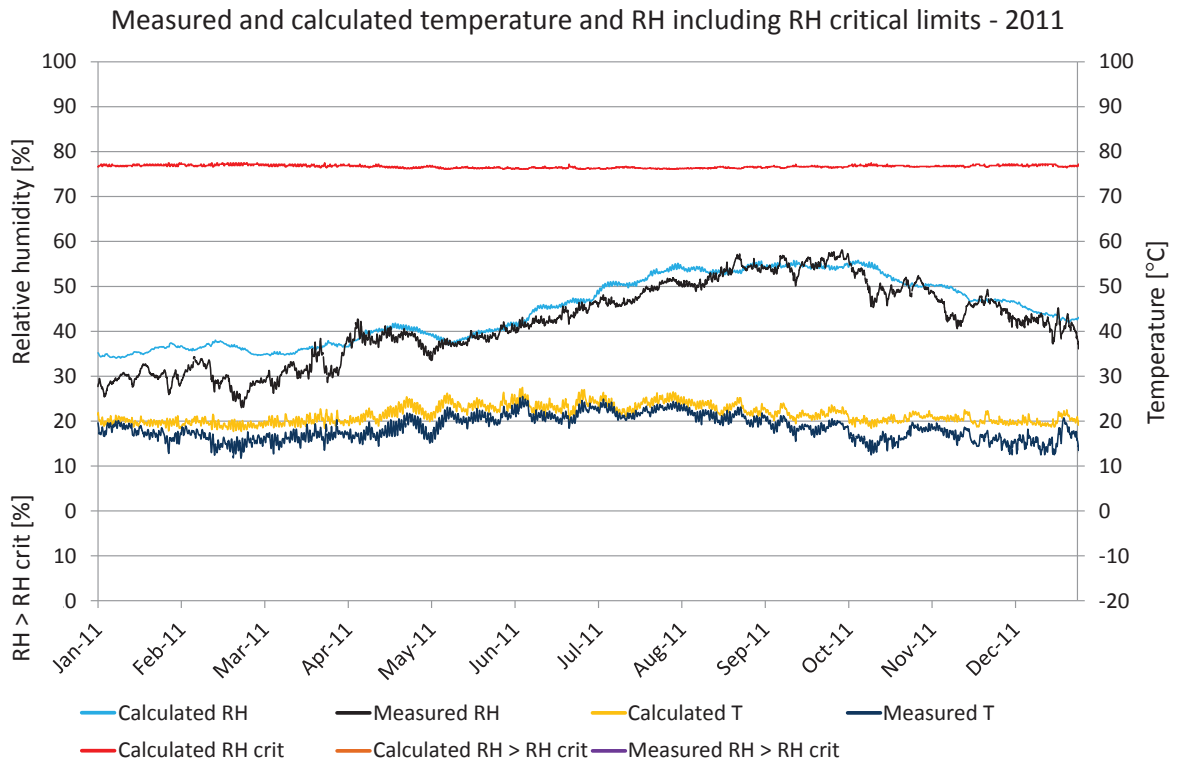

Figure 7.3.13. Comparisons between measured and calculated temperature and relative humidity. Calculated temperature (yellow), measured temperature (dark blue), calculated RH (turquoise), measured RH (black),  $RH_{crit}$  for calculated values (red), calculated  $RH > RH_{crit}$  (light brown), measured  $RH > RH_{crit}$  (purple).

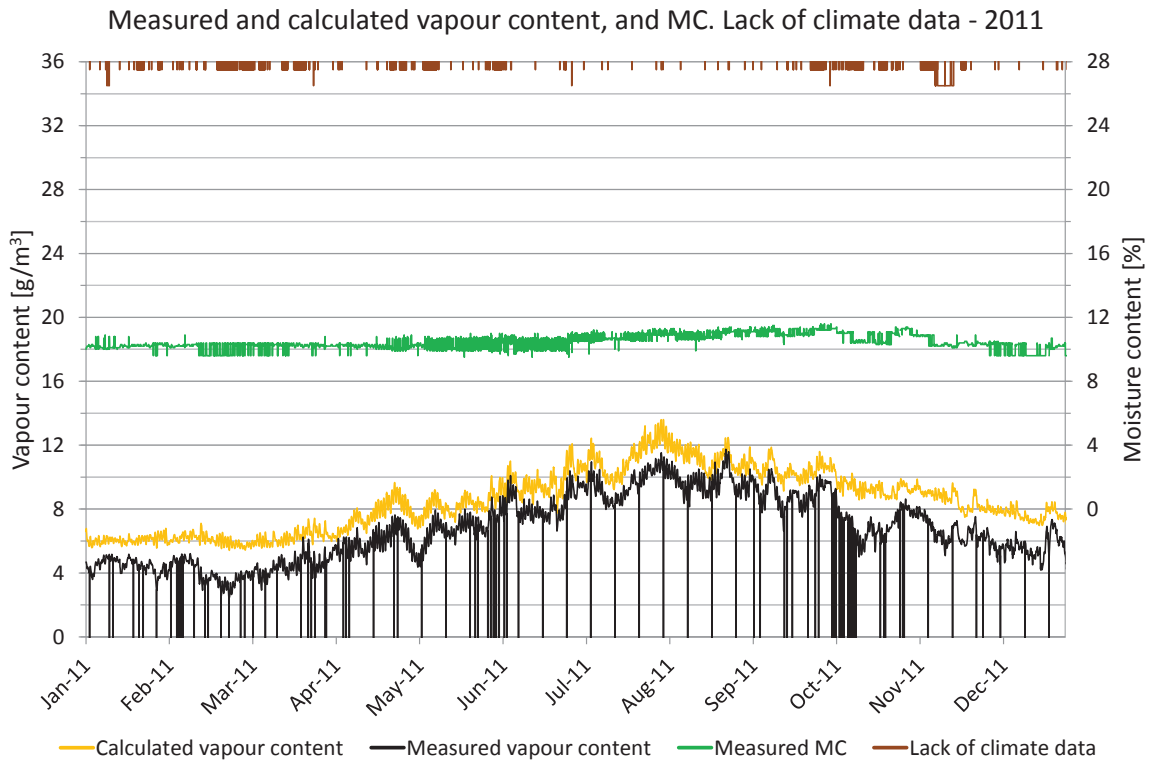

Figure 7.3.14. Measured moisture content, periods lacking climate data and comparisons of vapour content. Vapour content for calculated values (yellow) and measured values (black). Moisture content (green), periods with lack of climate data (brown).

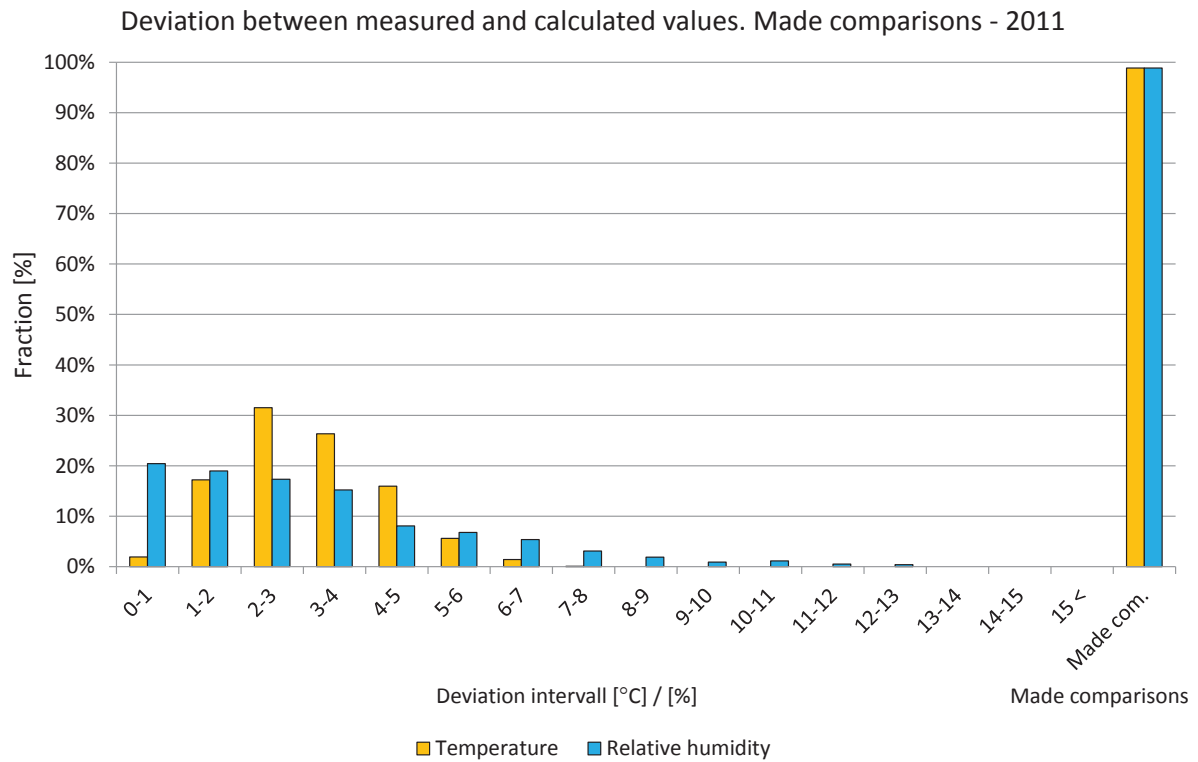

Figure 7.3.15. Deviations in comparisons shown in intervals from 0 to 15 °C or %. The two right-hand bars show the percentage of comparisons during the year. Temperature (yellow) and relative humidity (light blue).



## 7.4 Position 4

The locations of the measured and calculated position are shown in the drawings and figures below. The studied position is located in a wall facing northwest below a window on the second floor.

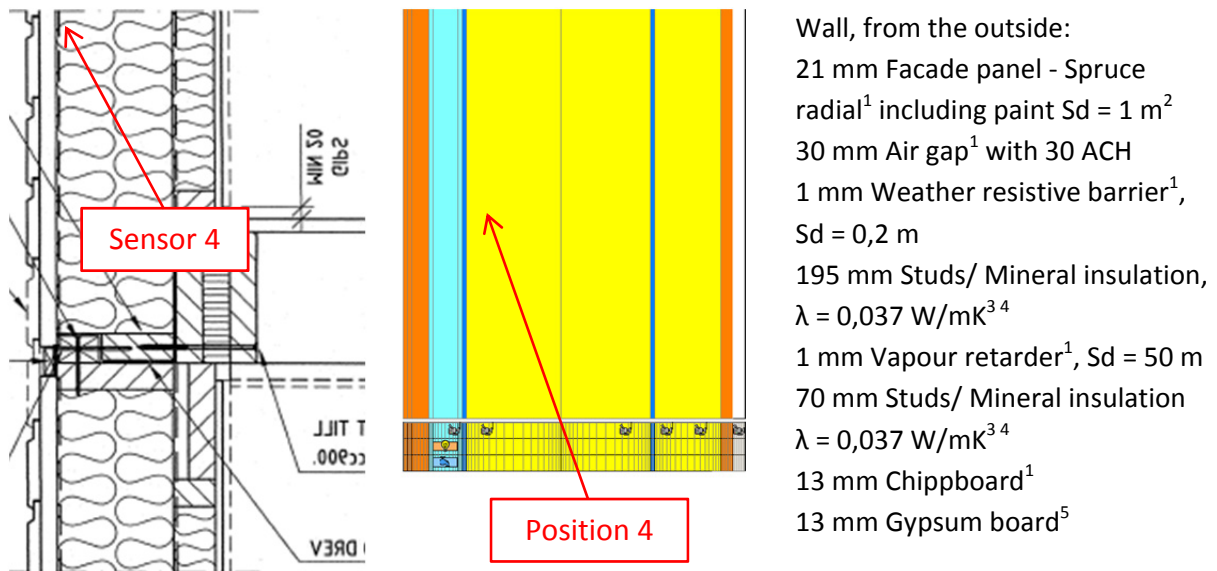

Figure 7.4.1. Vertical cross sectional drawing and WUFI calculation model showing the studied position. 1. IBP, 2012, 2. Nevander, L-E., 1994, 3. IEA Annex 24, 1996, 4. Paroc, 2002, 5. Krus, M., 1996.

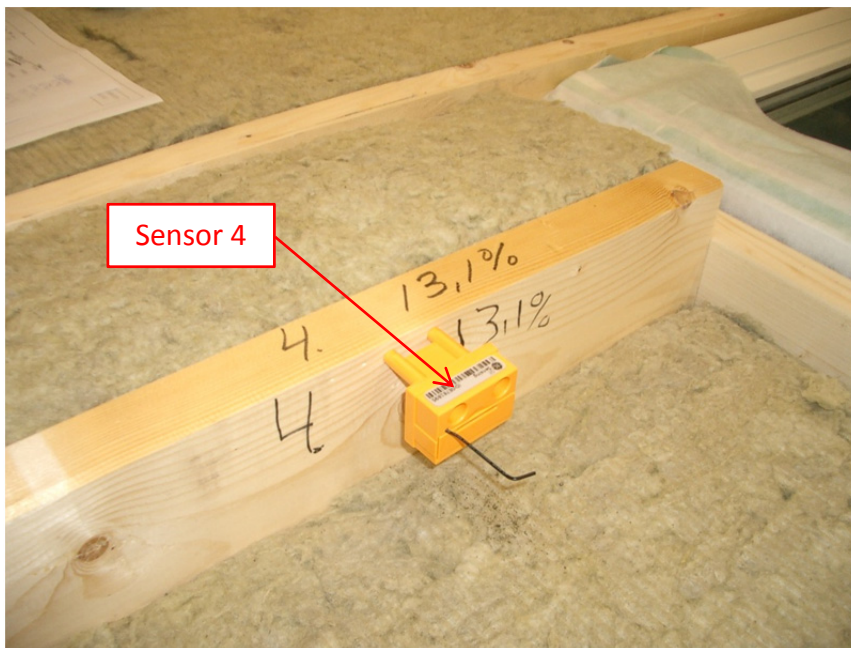

Figure 7.4.2. Location of the studied position.

A perfect match between the measured and calculated values cannot be expected due to e.g. the influence of two- and three-dimensional effects and the accuracy of the sensors.

**Year 2008**

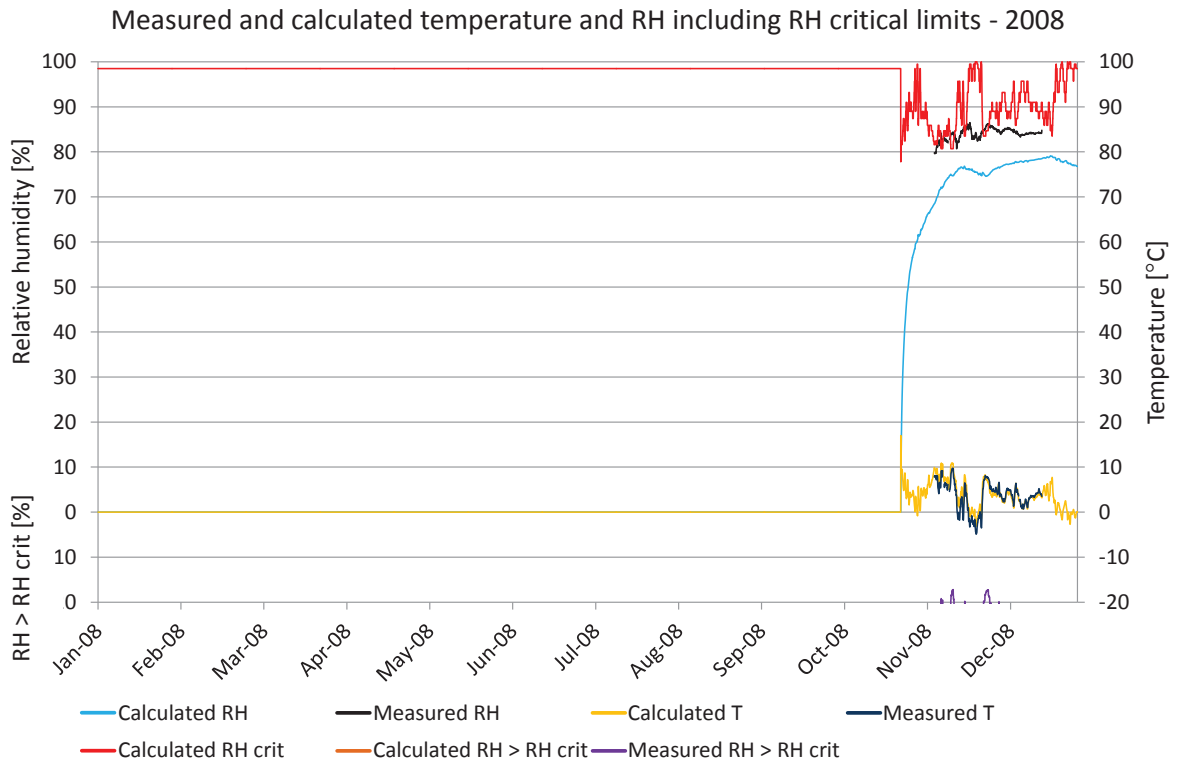

Figure 7.4.3. Comparisons between measured and calculated temperature and relative humidity. Calculated temperature (yellow), measured temperature (dark blue), calculated RH (turquoise), measured RH (black),  $RH_{crit}$  for calculated values (red), calculated  $RH > RH_{crit}$  (light brown), measured  $RH > RH_{crit}$  (purple).

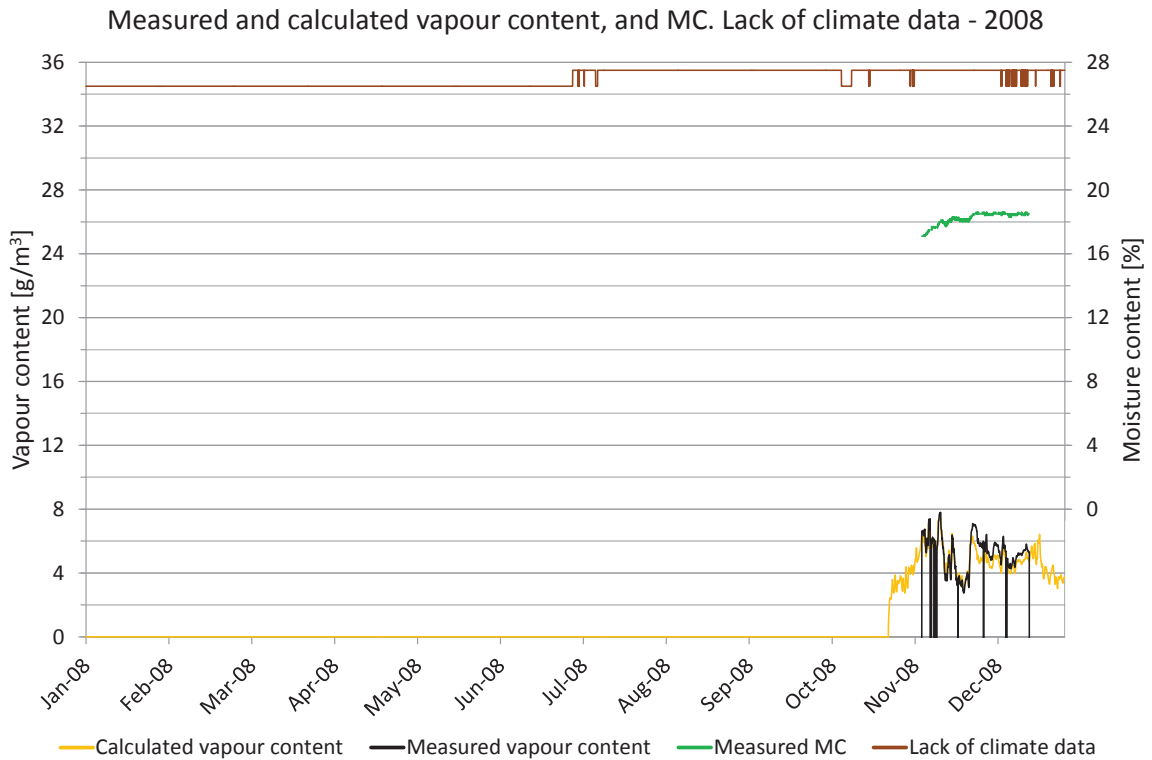

Figure 7.4.4. Measured moisture content, periods lacking climate data and comparisons of vapour content. Vapour content for calculated values (yellow) and measured values (black). Moisture content (green), periods with lack of climate data (brown).

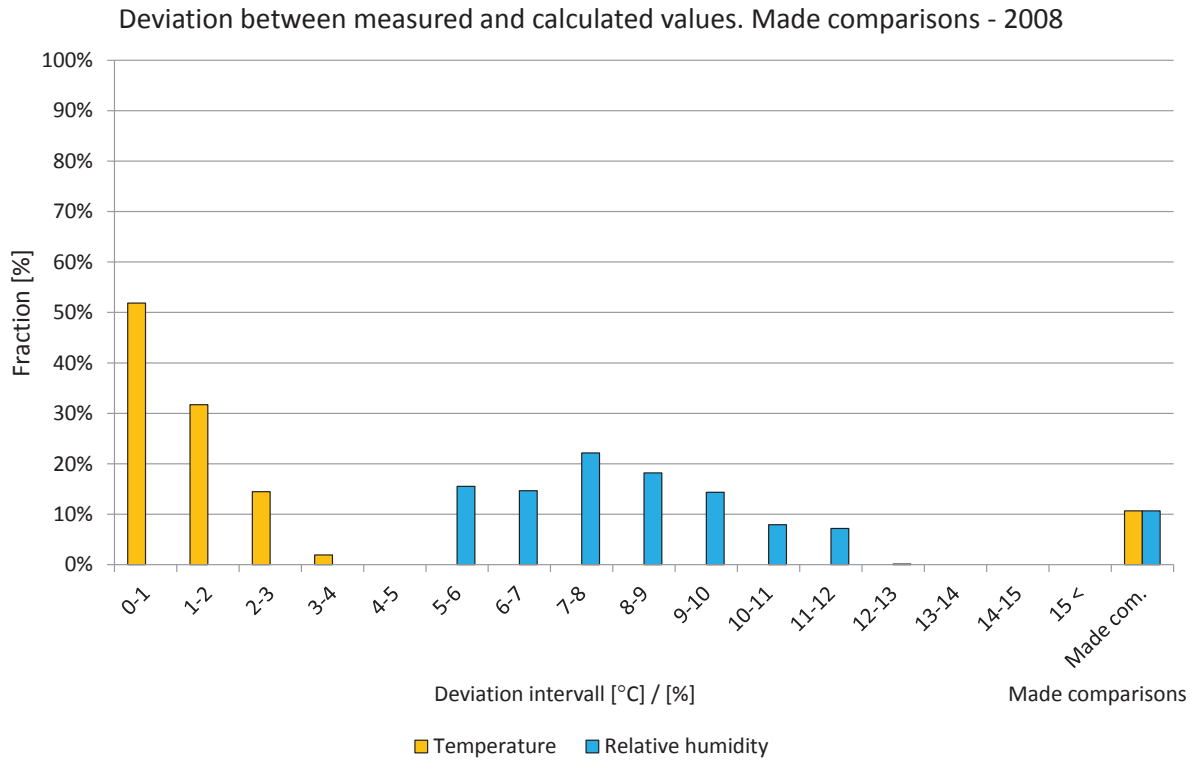

Figure 7.4.5. Deviations in comparisons shown in intervals from 0 to 15 °C or %. The two right-hand bars show the percentage of comparisons during the year. Temperature (yellow) and relative humidity (light blue).

### Year 2009

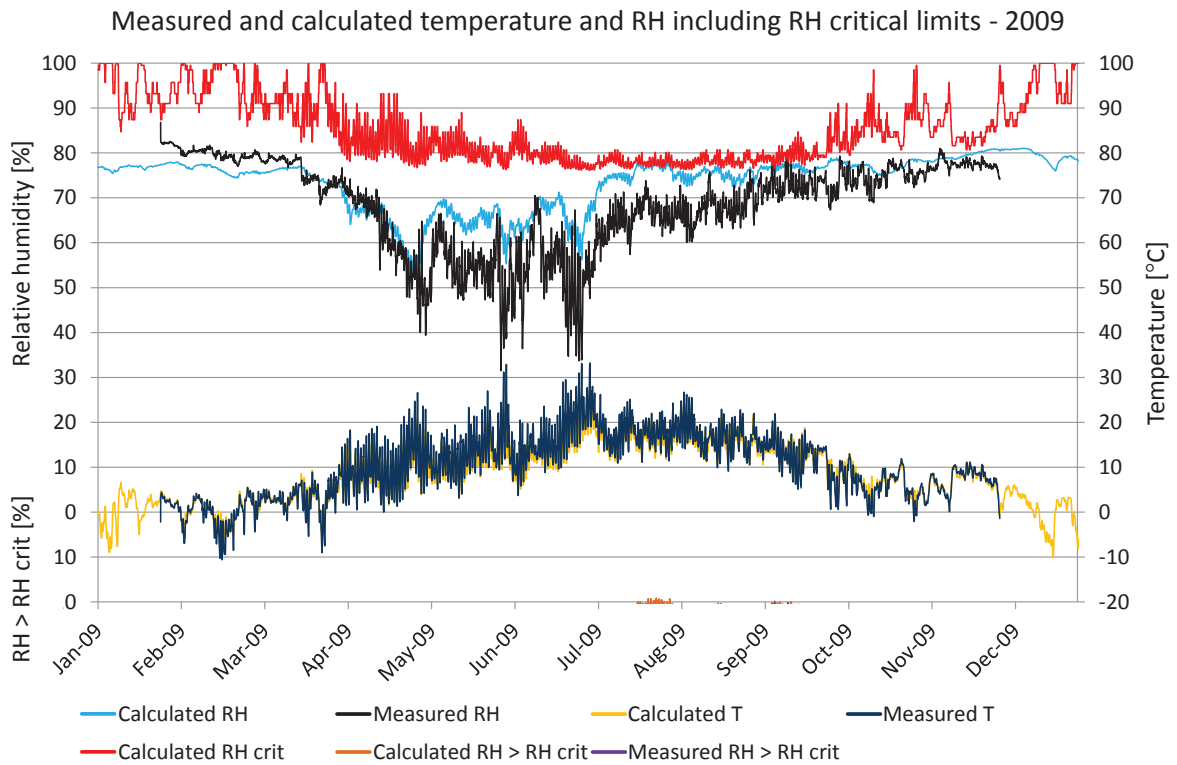

Figure 7.4.6. Comparisons between measured and calculated temperature and relative humidity. Calculated temperature (yellow), measured temperature (dark blue), calculated RH (turquoise), measured RH (black),  $RH_{crit}$  for calculated values (red), calculated  $RH > RH_{crit}$  (light brown), measured  $RH > RH_{crit}$  (purple).

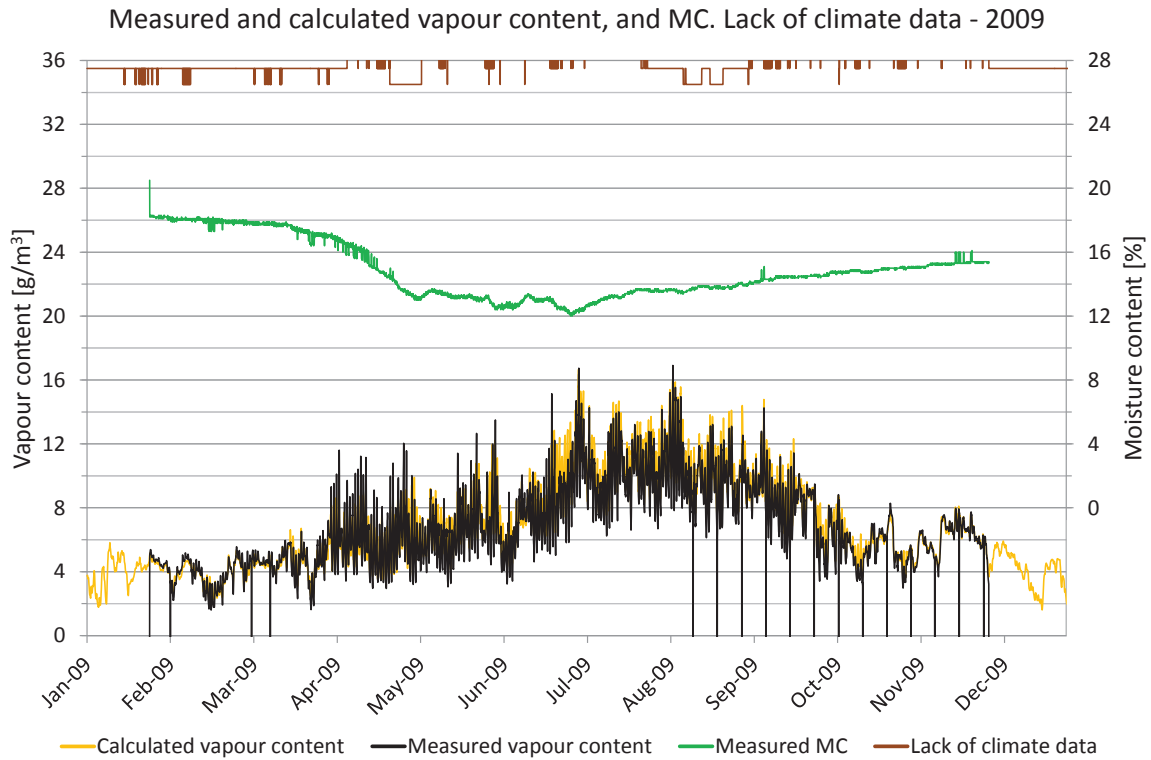

Figure 7.4.7. Measured moisture content, periods lacking climate data and comparisons of vapour content. Vapour content for calculated values (yellow) and measured values (black). Moisture content (green), periods with lack of climate data (brown).

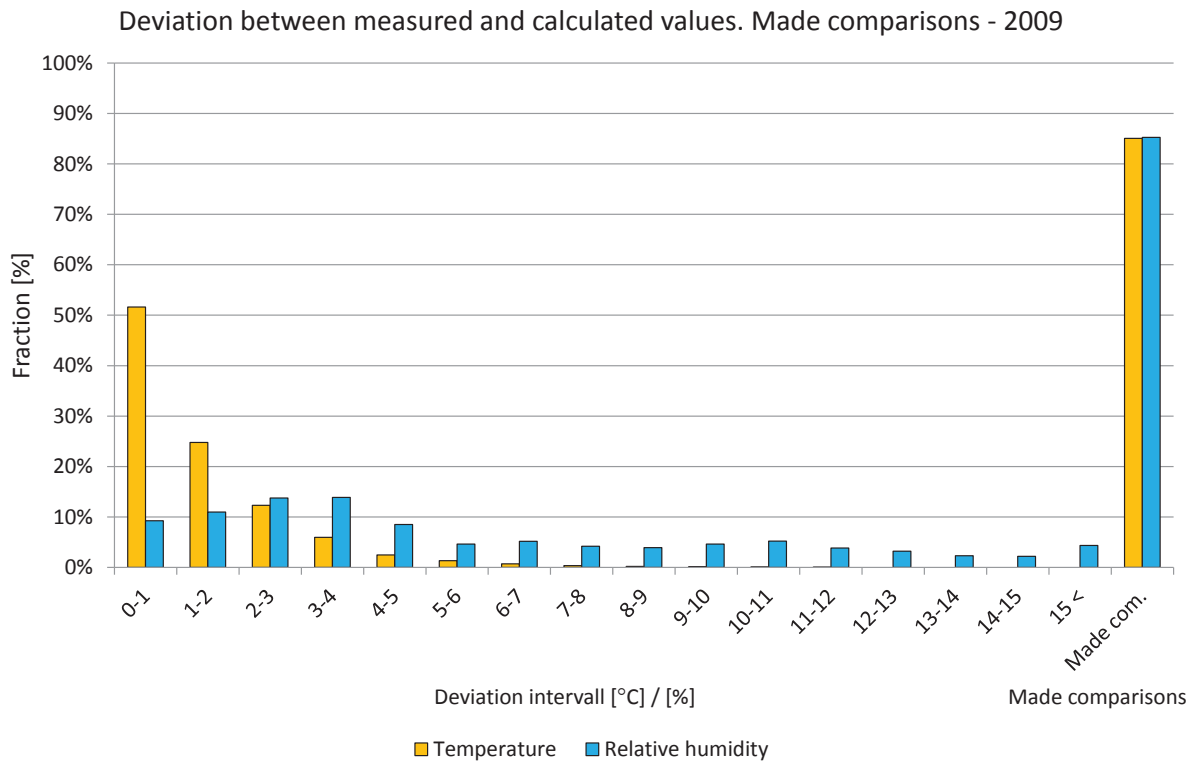

Figure 7.4.8. Deviations in comparisons shown in intervals from 0 to 15 °C or %. The two right-hand bars show the percentage of comparisons during the year. Temperature (yellow) and relative humidity (light blue).

**Year 2010**

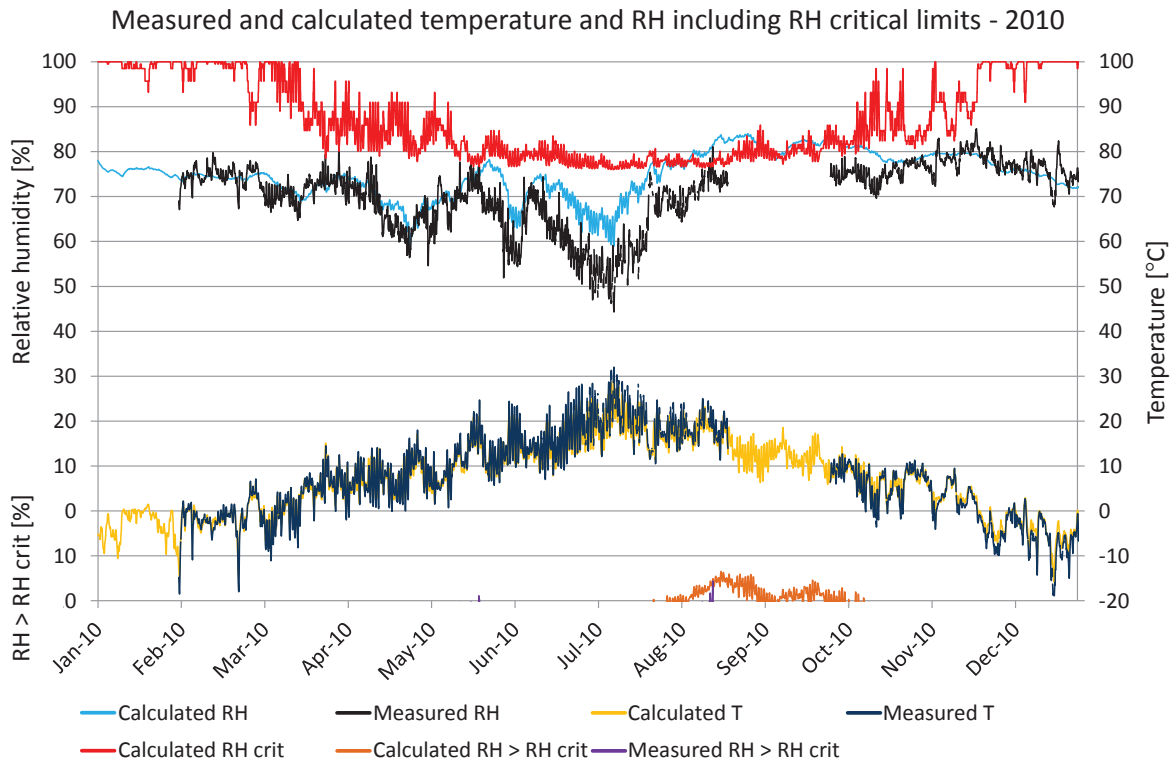

Figure 7.4.9. Comparisons between measured and calculated temperature and relative humidity. Calculated temperature (yellow), measured temperature (dark blue), calculated RH (turquoise), measured RH (black),  $RH_{crit}$  for calculated values (red), calculated  $RH > RH_{crit}$  (light brown), measured  $RH > RH_{crit}$  (purple).

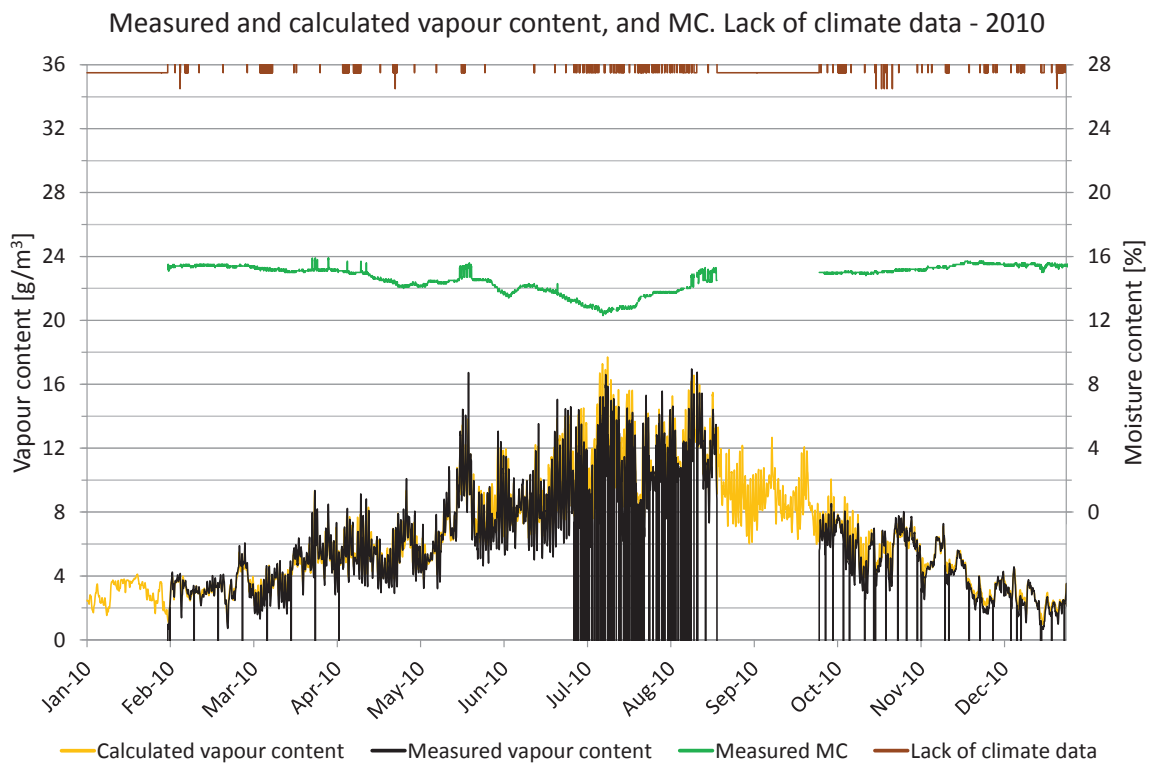

Figure 7.4.10. Measured moisture content, periods lacking climate data and comparisons of vapour content. Vapour content for calculated values (yellow) and measured values (black). Moisture content (green), periods with lack of climate data (brown).

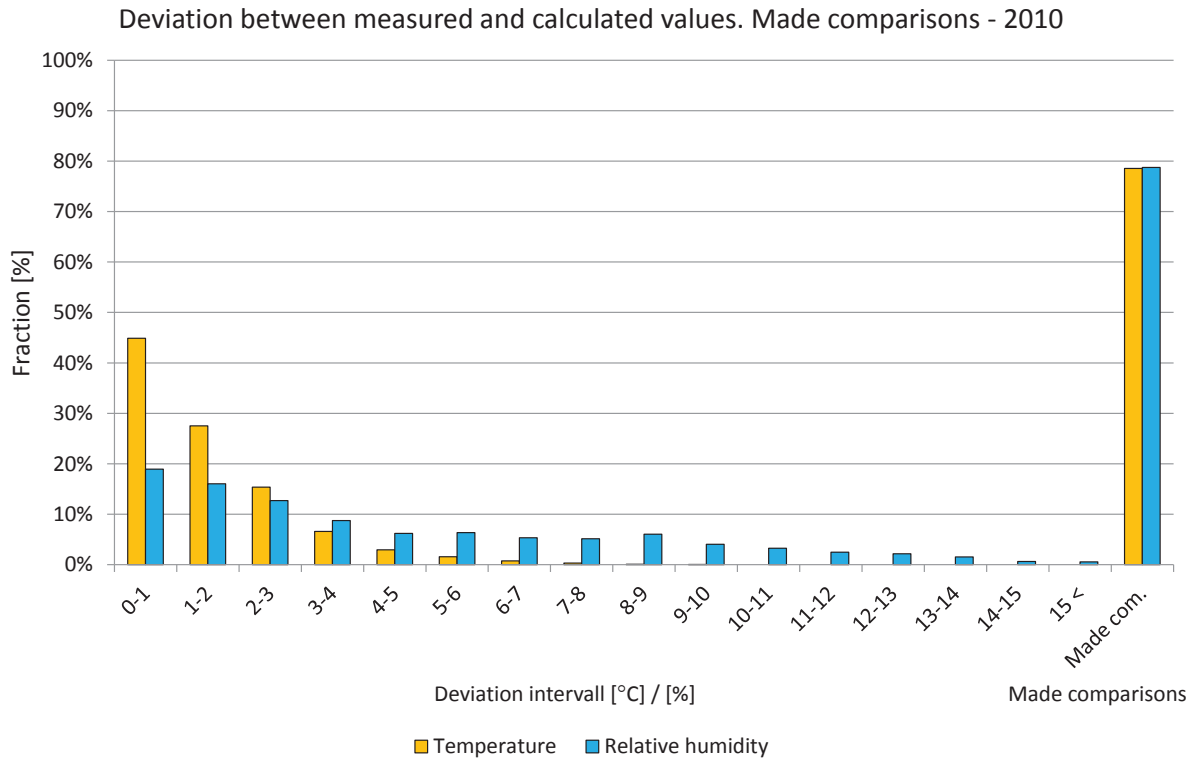

Figure 7.4.11. Deviations in comparisons shown in intervals from 0 to 15 °C or %. The two right-hand bars show the percentage of comparisons during the year. Temperature (yellow) and relative humidity (light blue).

### Year 2011

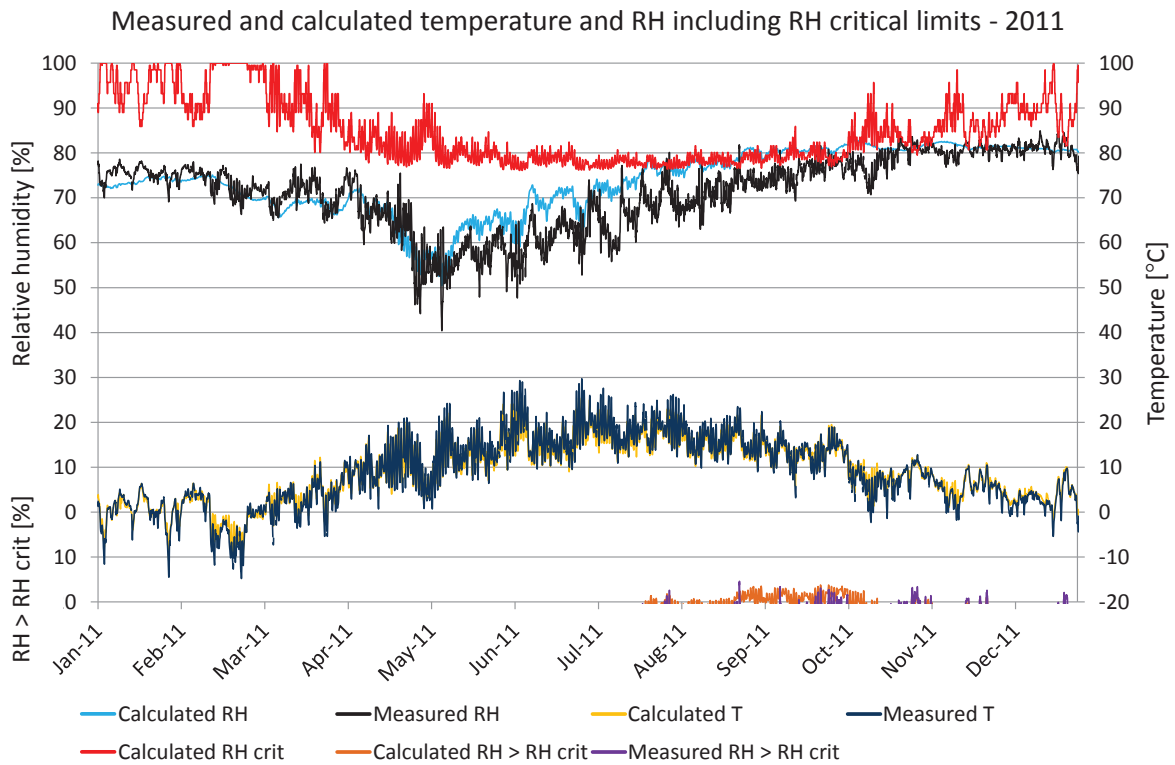

Figure 7.4.12. Comparisons between measured and calculated temperature and relative humidity. Calculated temperature (yellow), measured temperature (dark blue), calculated RH (turquoise), measured RH (black),  $RH_{crit}$  for calculated values (red), calculated  $RH > RH_{crit}$  (light brown), measured  $RH > RH_{crit}$  (purple).

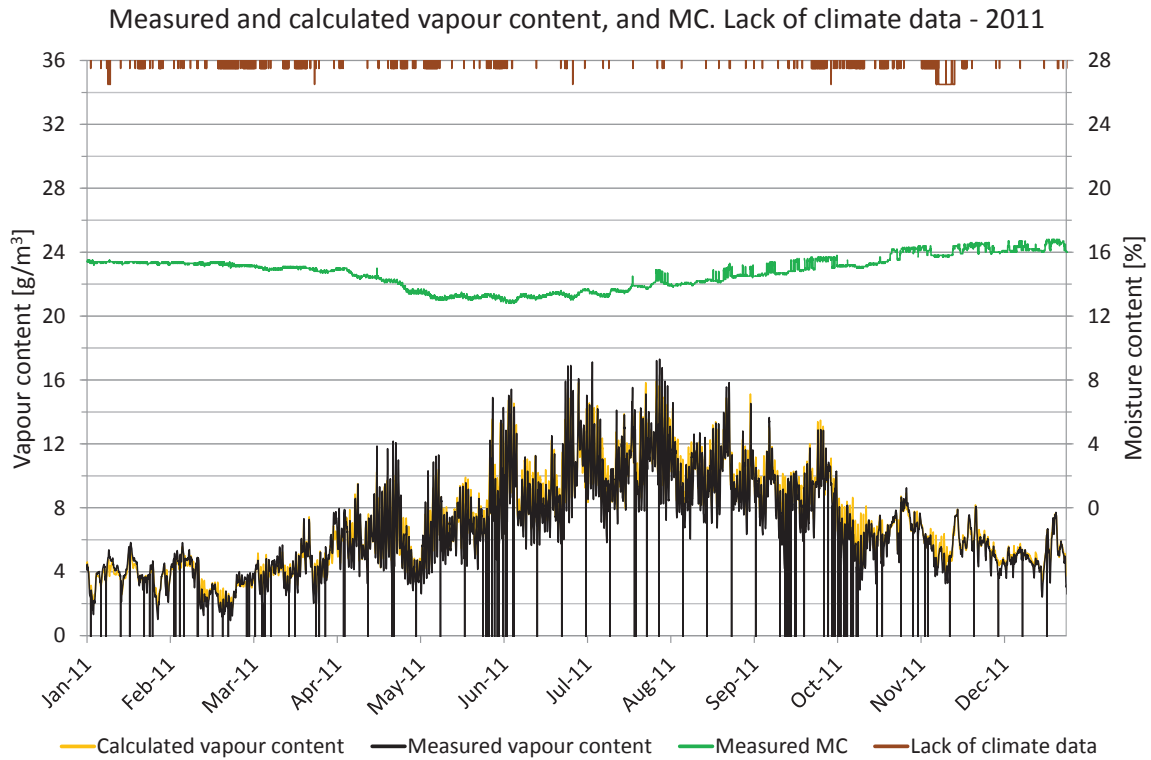

Figure 7.4.13. Measured moisture content, periods lacking climate data and comparisons of vapour content. Vapour content for calculated values (yellow) and measured values (black). Moisture content (green), periods with lack of climate data (brown).

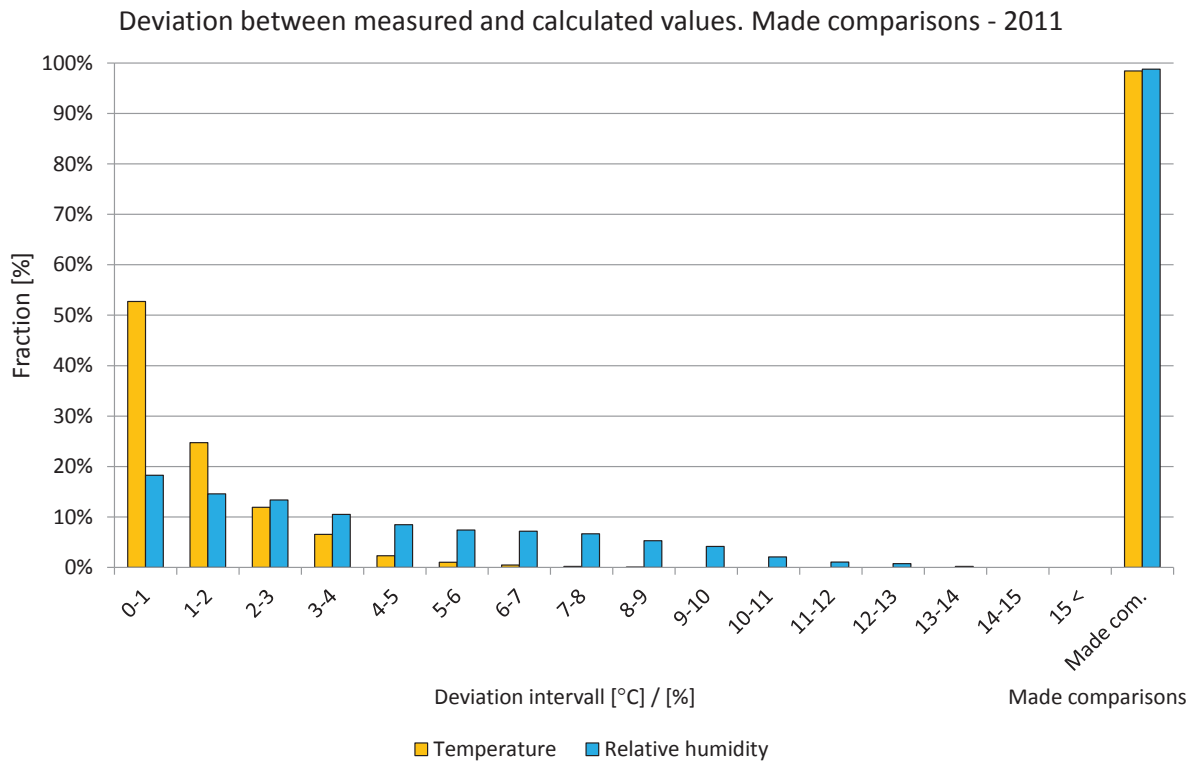

Figure 7.4.14. Deviations in comparisons shown in intervals from 0 to 15 °C or %. The two right-hand bars show the percentage of comparisons during the year. Temperature (yellow) and relative humidity (light blue).





## 7.5 Position 5

The locations of the measured and calculated position are shown in the drawings and figures below. The studied position is located in a wall facing southeast below a window on the first floor.

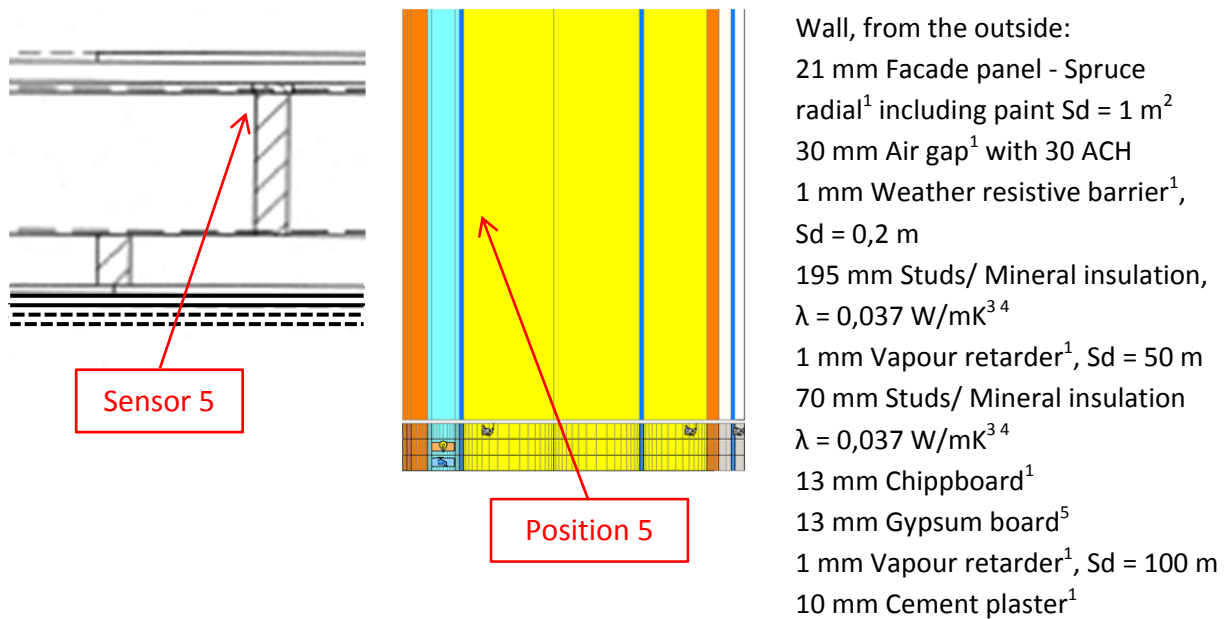

Figure 7.5.1. Vertical cross sectional drawing and WUFI calculation model showing the studied position. 1. IBP, 2012, 2. Nevander, L-E., 1994, 3. IEA Annex 24, 1996, 4. Paroc, 2002, 5. Krus, M., 1996.

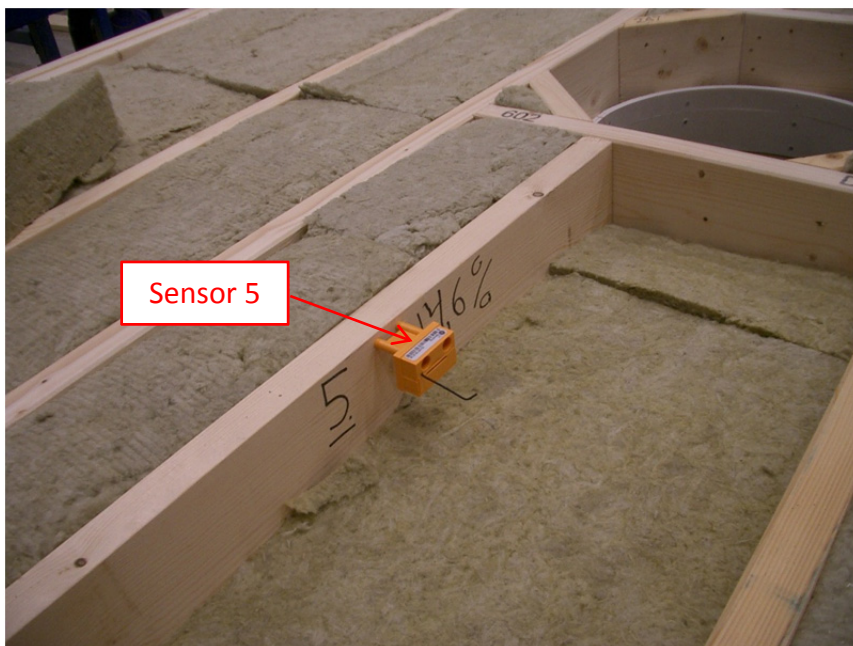

Figure 7.5.2. Location of the studied position.

A perfect match between the measured and calculated values cannot be expected due to e.g. the influence of two- and three-dimensional effects and the accuracy of the sensors.

**Year 2008**

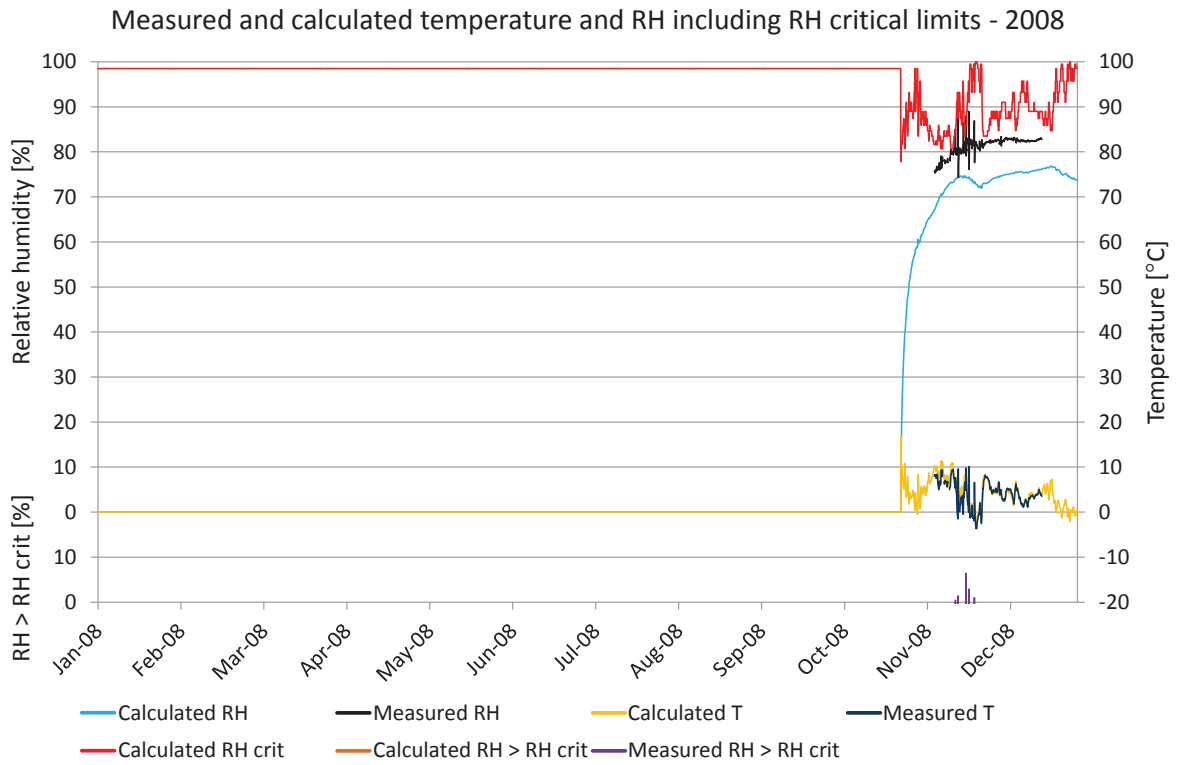

Figure 7.5.3. Comparisons between measured and calculated temperature and relative humidity. Calculated temperature (yellow), measured temperature (dark blue), calculated RH (turquoise), measured RH (black),  $RH_{crit}$  for calculated values (red), calculated  $RH > RH_{crit}$  (light brown), measured  $RH > RH_{crit}$  (purple).

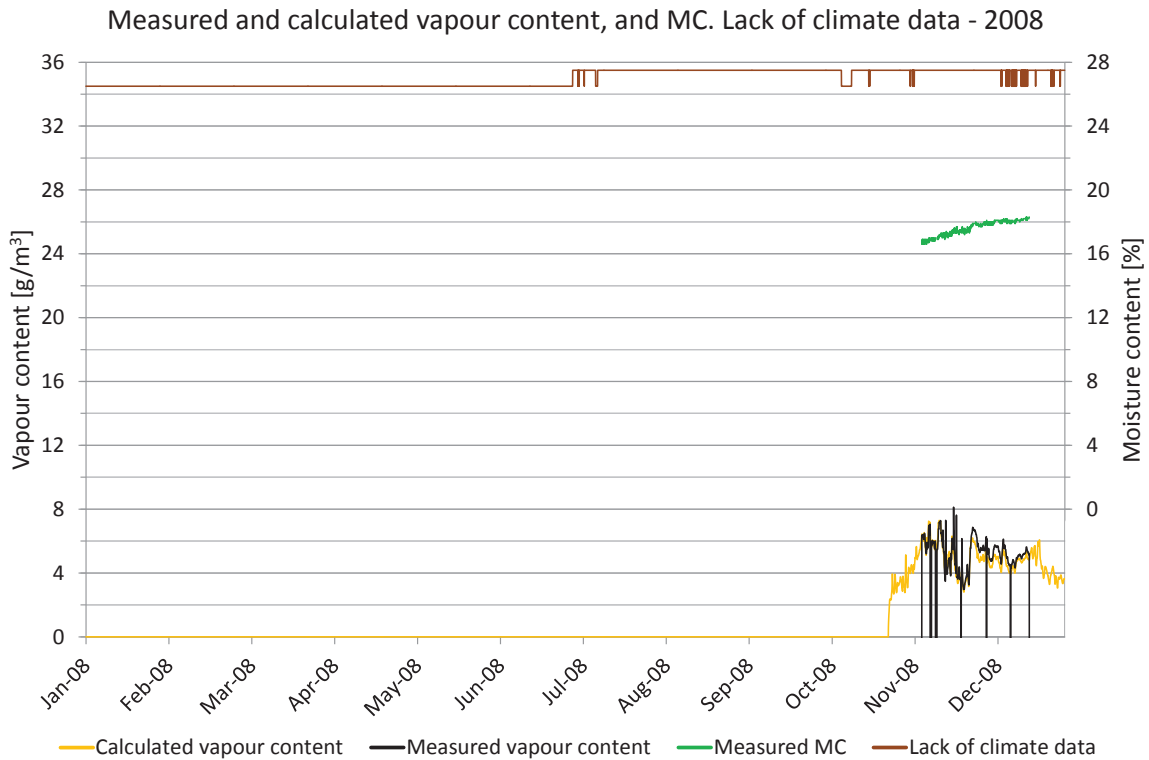

Figure 7.5.4. Measured moisture content, periods lacking climate data and comparisons of vapour content. Vapour content for calculated values (yellow) and measured values (black). Moisture content (green), periods with lack of climate data (brown).

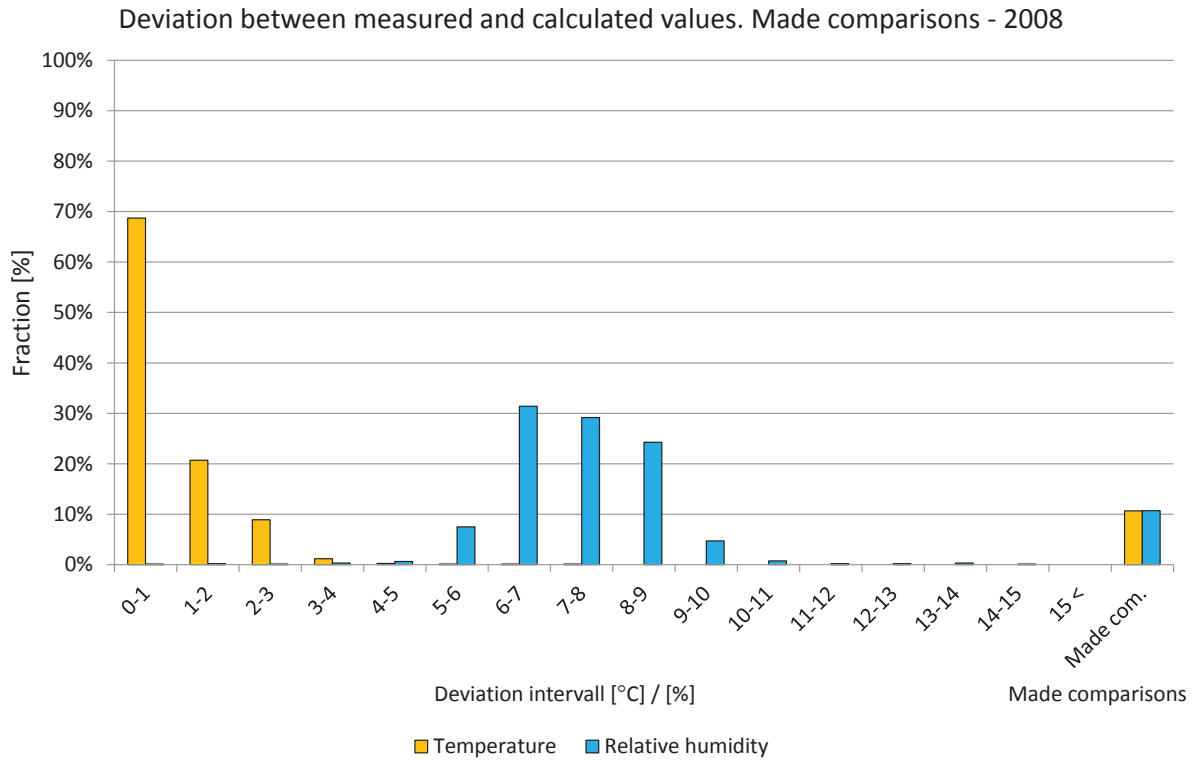

Figure 7.5.5. Deviations in comparisons shown in intervals from 0 to 15 °C or %. The two right-hand bars show the percentage of comparisons during the year. Temperature (yellow) and relative humidity (light blue).

### Year 2009

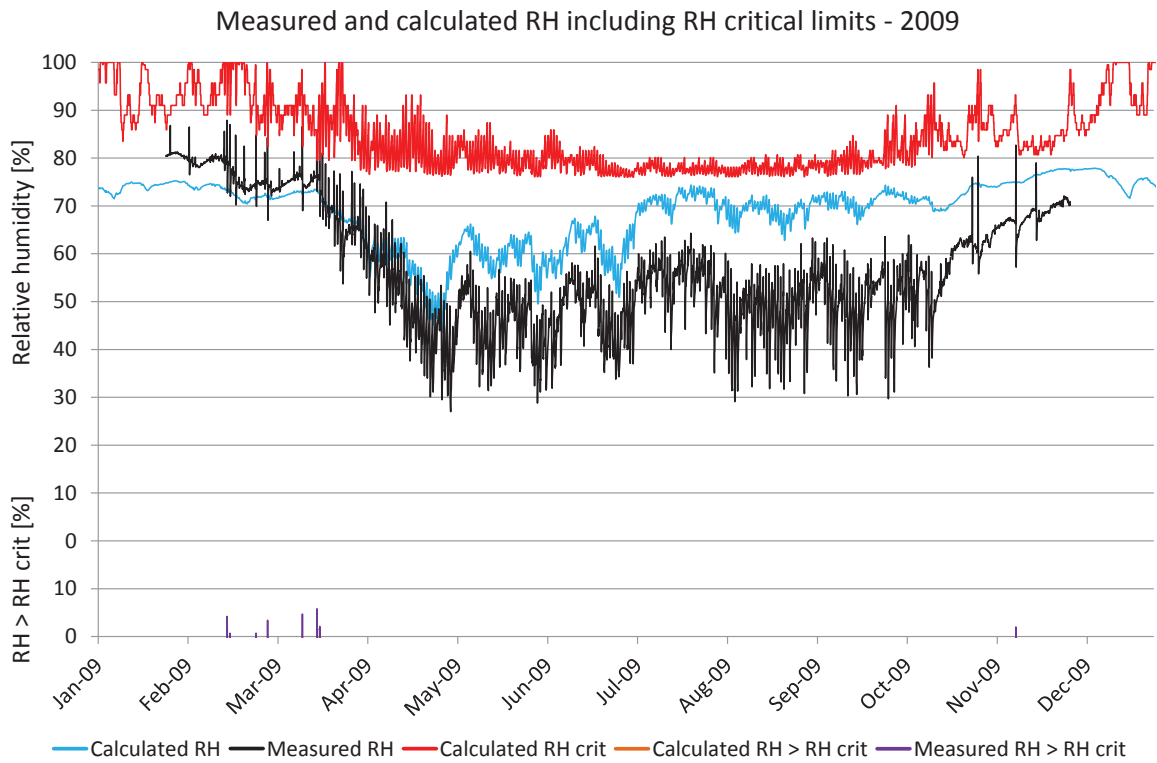

Figure 7.5.6. Comparisons between measured and calculated relative humidity. Calculated RH (turquoise), measured RH (black),  $RH_{crit}$  for calculated values (red), calculated  $RH > RH_{crit}$  (light brown), measured  $RH > RH_{crit}$  (purple).

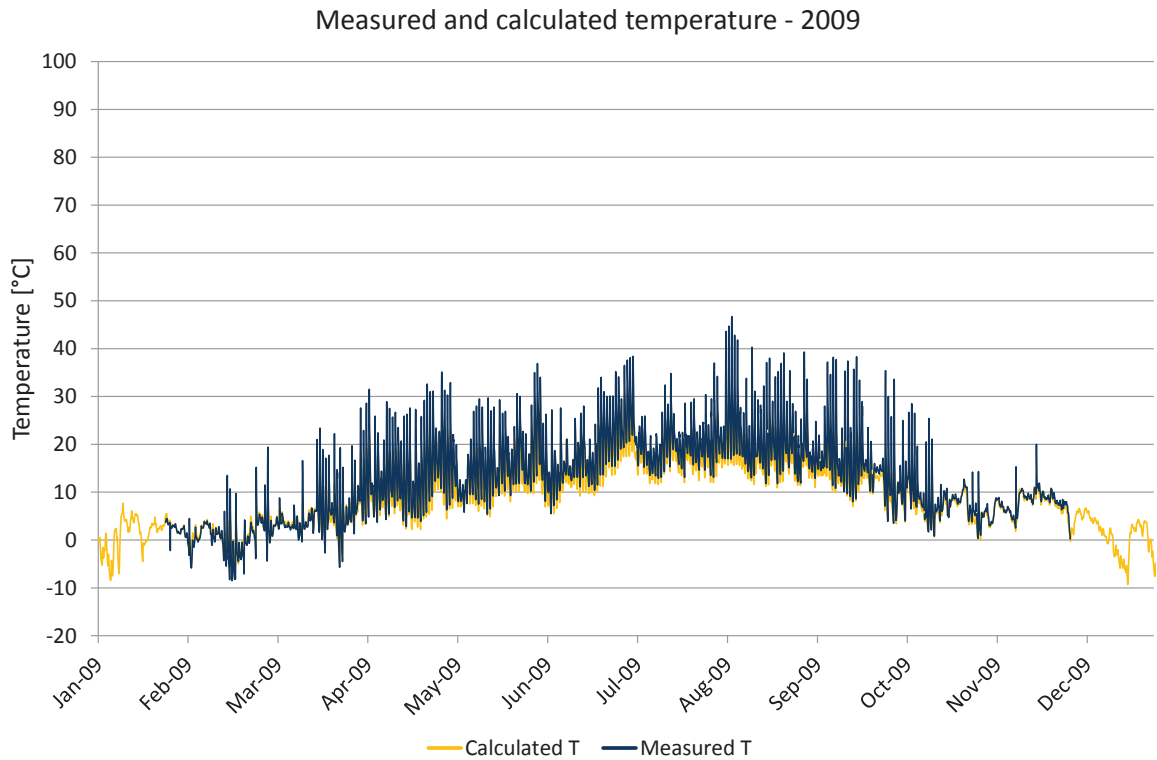

Figure 7.5.7. Comparisons between measured and calculated temperature. Calculated temperature (yellow), measured temperature (dark blue).

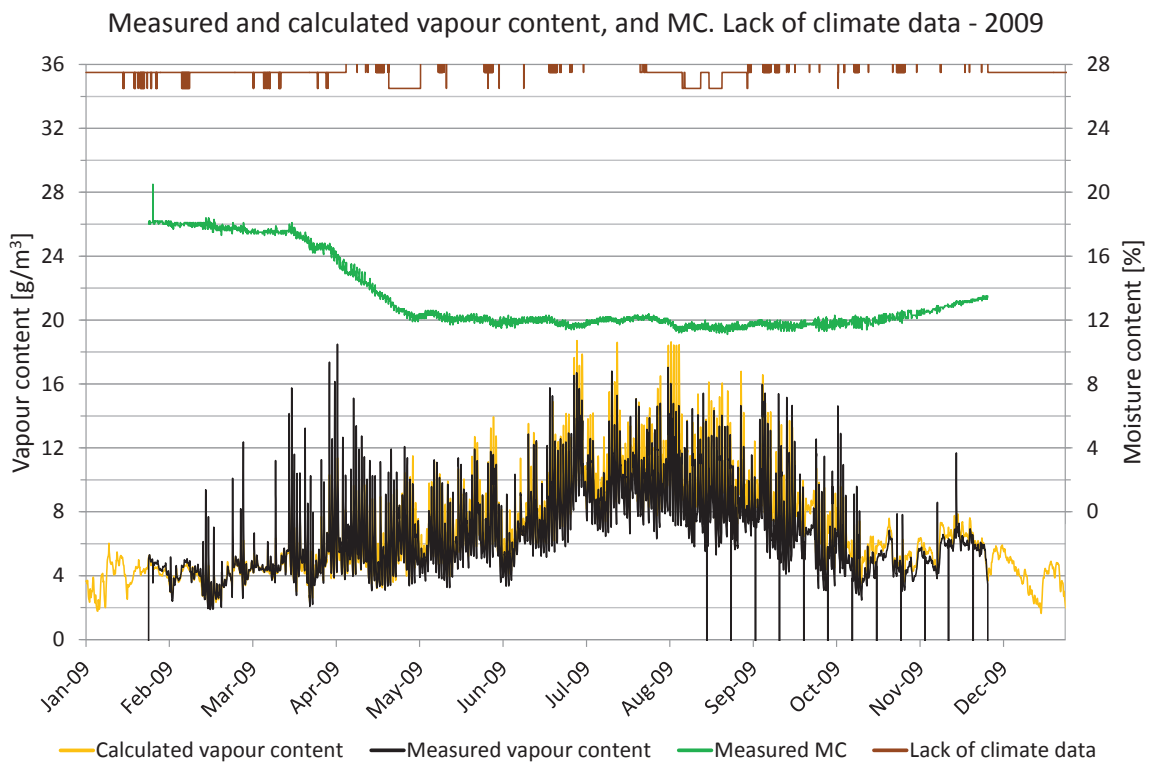

Figure 7.5.8. Measured moisture content, periods lacking climate data and comparisons of vapour content. Vapour content for calculated values (yellow) and measured values (black). Moisture content (green), periods with lack of climate data (brown).

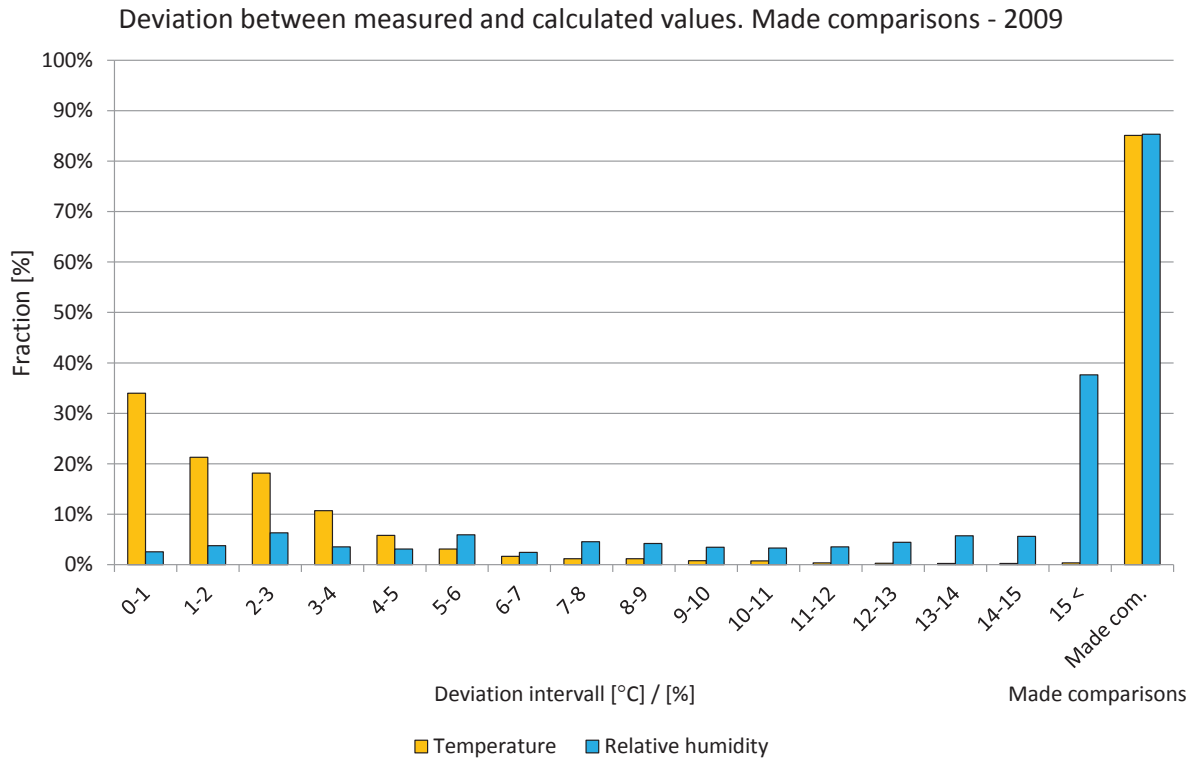

Figure 7.5.9. Deviations in comparisons shown in intervals from 0 to 15 °C or %. The two right-hand bars show the percentage of comparisons during the year. Temperature (yellow) and relative humidity (light blue).

**Year 2010**

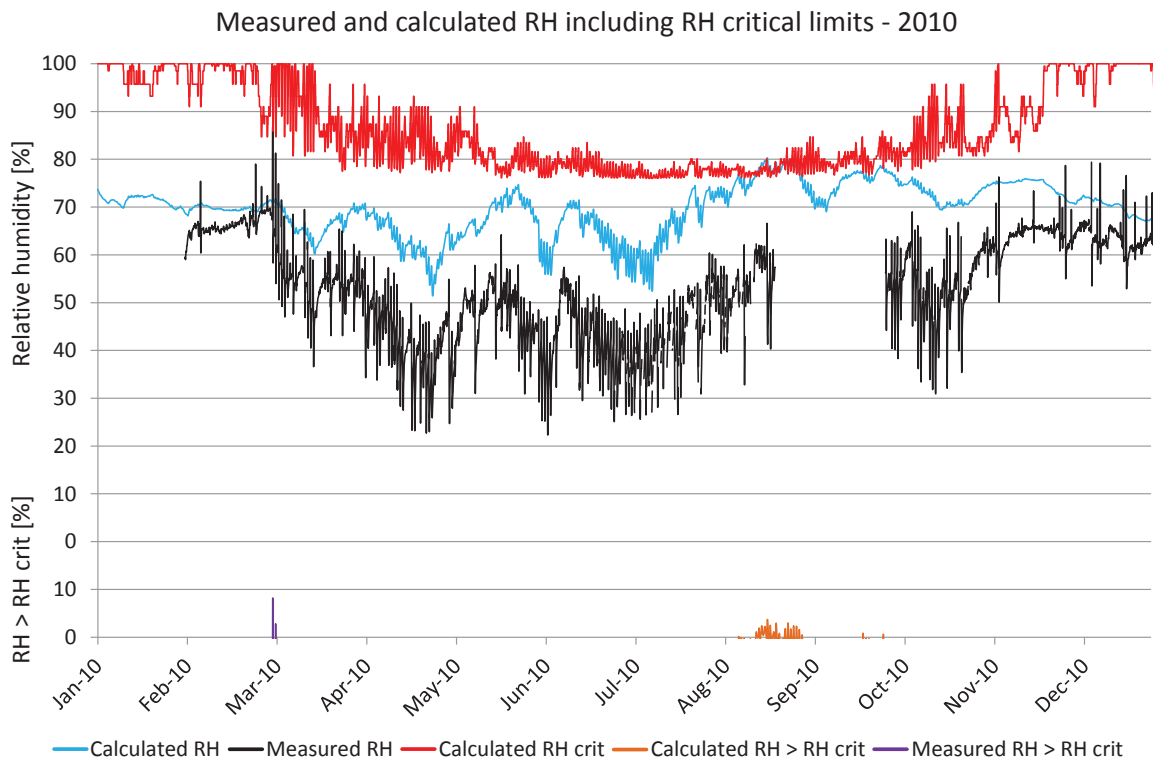

Figure 7.5.10. Comparisons between measured and calculated relative humidity. Calculated RH (turquoise), measured RH (black),  $RH_{crit}$  for calculated values (red), calculated  $RH > RH_{crit}$  (light brown), measured  $RH > RH_{crit}$  (purple).

Measured and calculated temperature - 2010

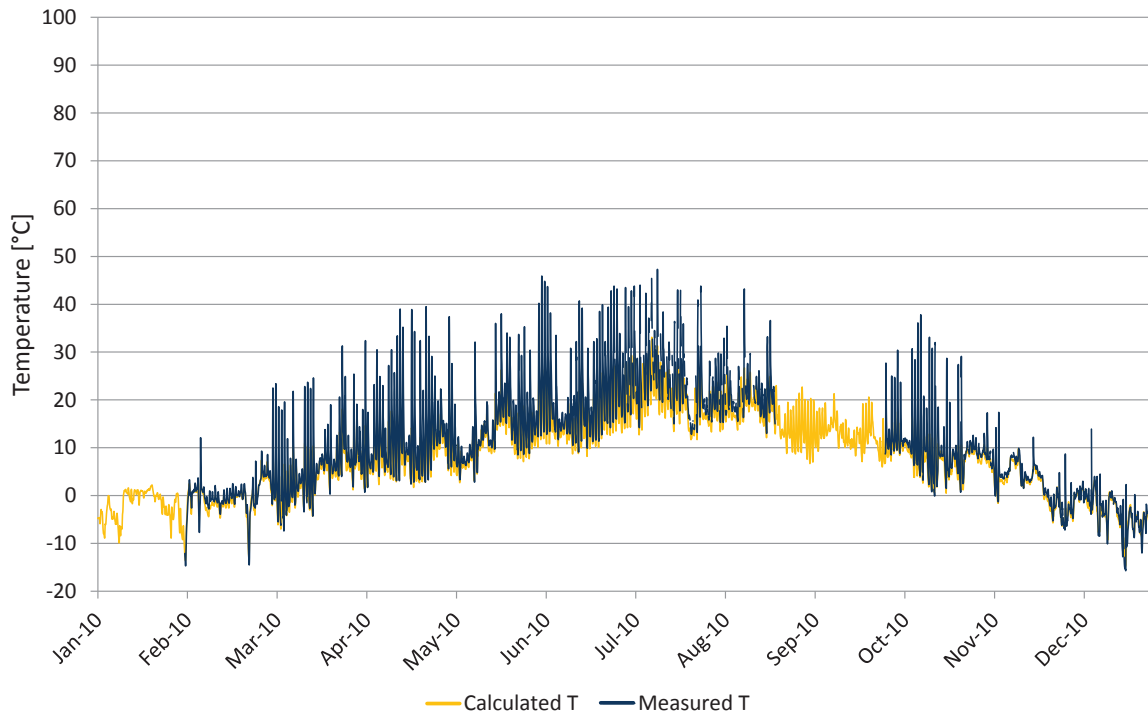

Figure 7.5.11. Comparisons between measured and calculated temperature. Calculated temperature (yellow), measured temperature (dark blue).

Measured and calculated vapour content, and MC. Lack of climate data - 2010

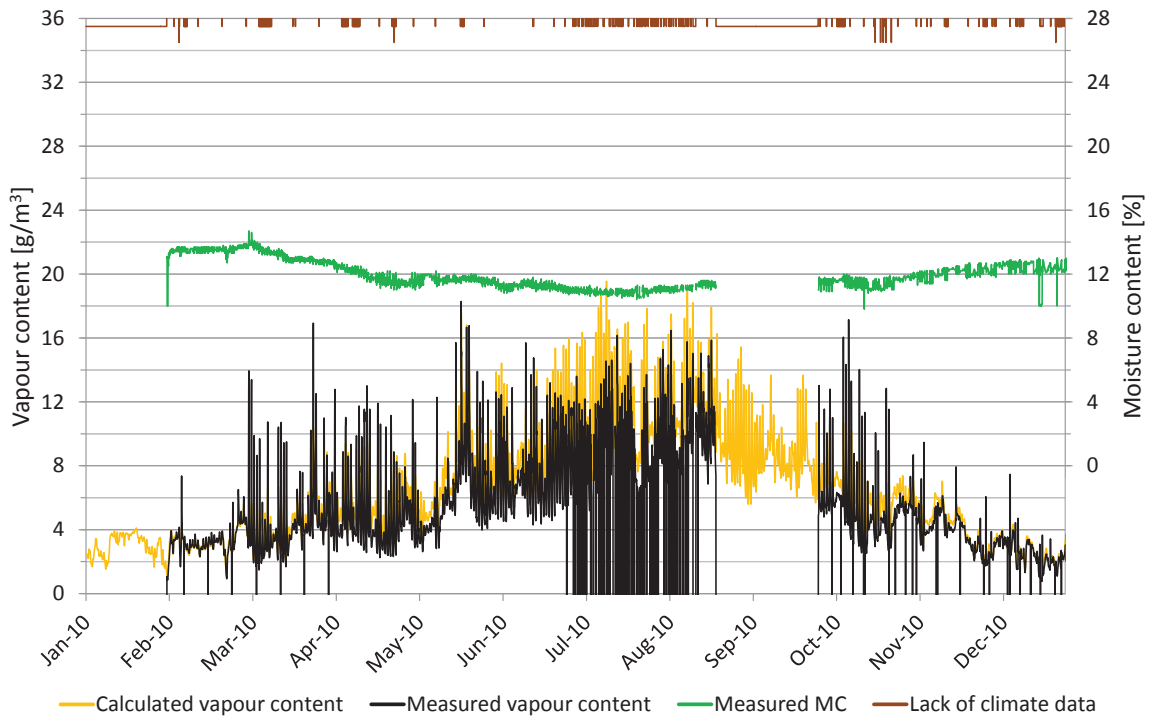

Figure 7.5.12. Measured moisture content, periods lacking climate data and comparisons of vapour content. Vapour content for calculated values (yellow) and measured values (black). Moisture content (green), periods with lack of climate data (brown).

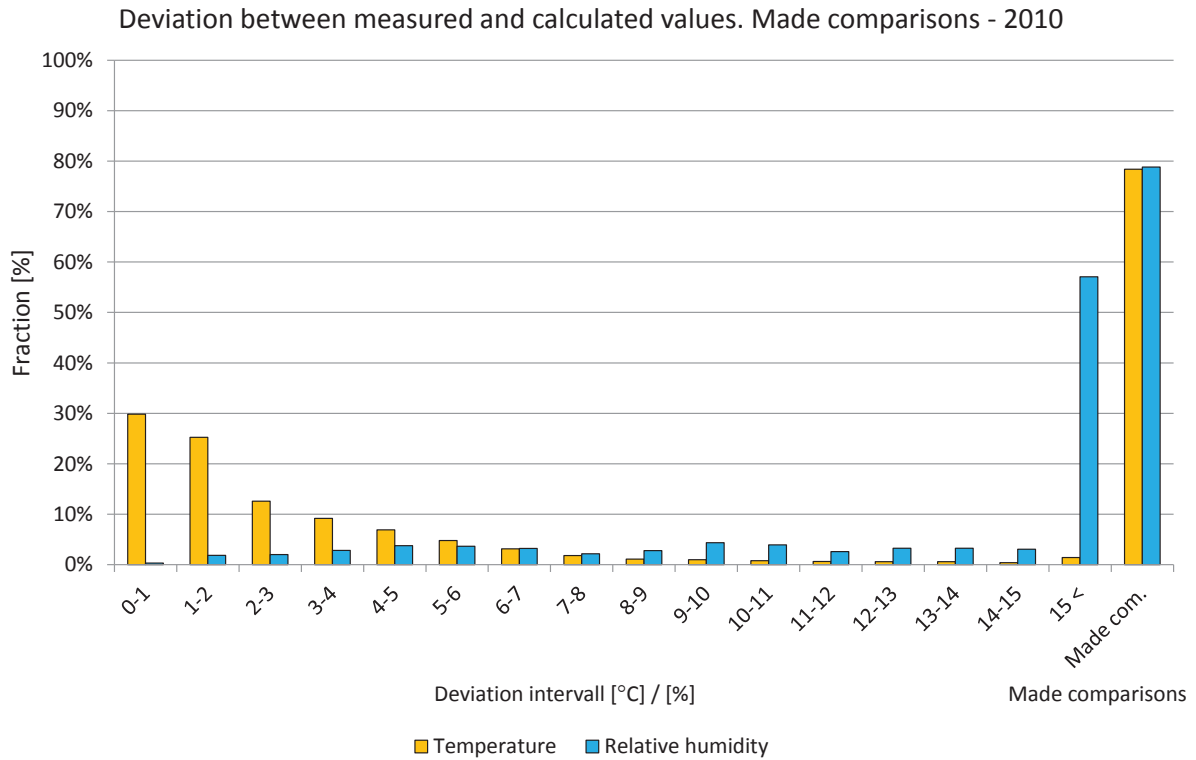

Figure 7.5.13. Deviations in comparisons shown in intervals from 0 to 15 °C or %. The two right-hand bars show the percentage of comparisons during the year. Temperature (yellow) and relative humidity (light blue).

**Year 2011**

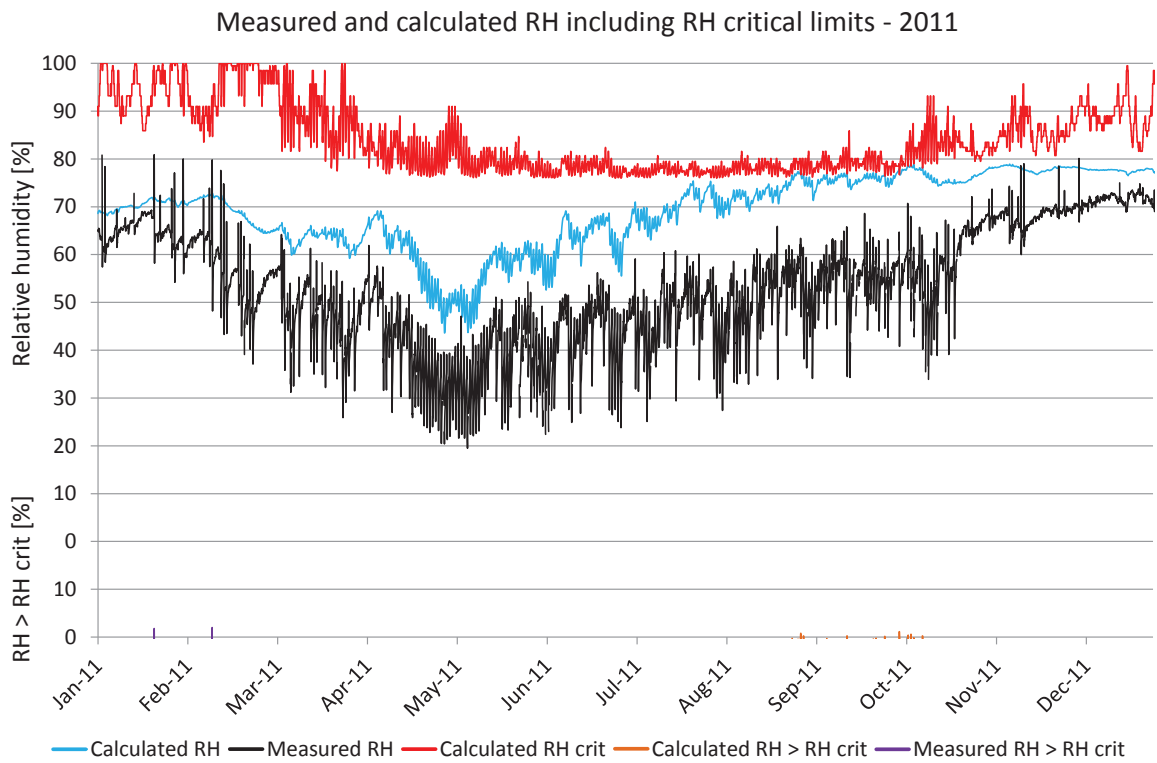

Figure 7.5.14. Comparisons between measured and calculated relative humidity. Calculated RH (turquoise), measured RH (black),  $RH_{crit}$  for calculated values (red), calculated  $RH > RH_{crit}$  (light brown), measured  $RH > RH_{crit}$  (purple).

Measured and calculated temperature - 2011

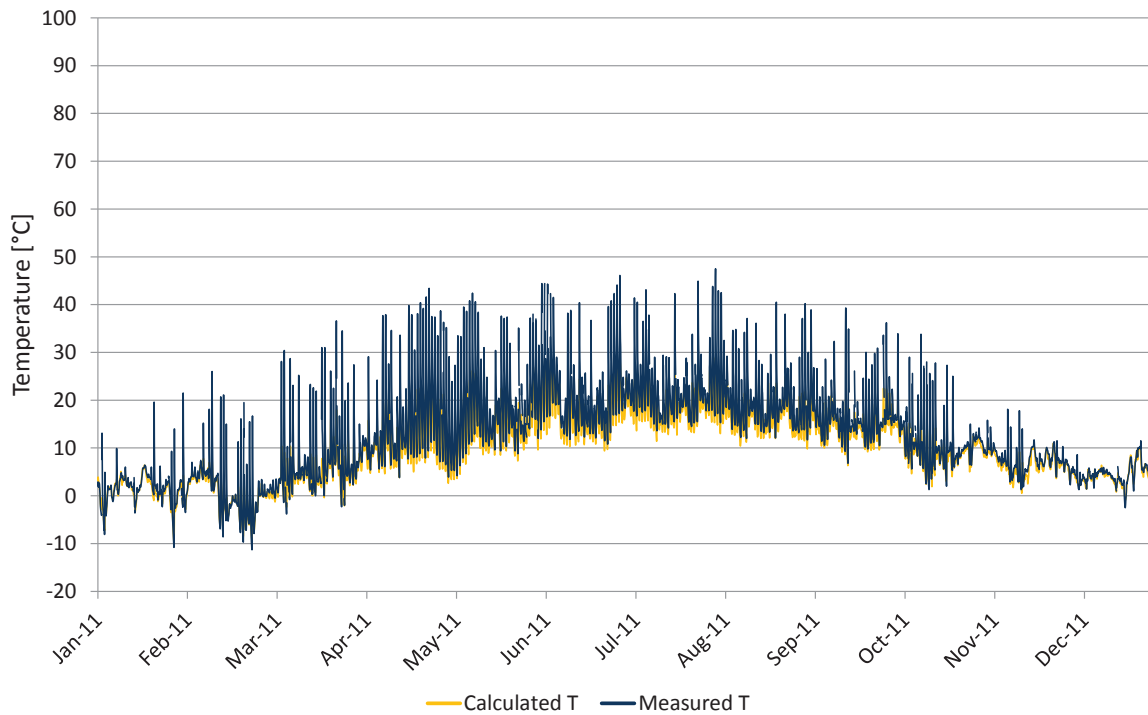

Figure 7.5.15. Comparisons between measured and calculated temperature. Calculated temperature (yellow), measured temperature (dark blue).

Measured and calculated vapour content, and MC. Lack of climate data - 2011

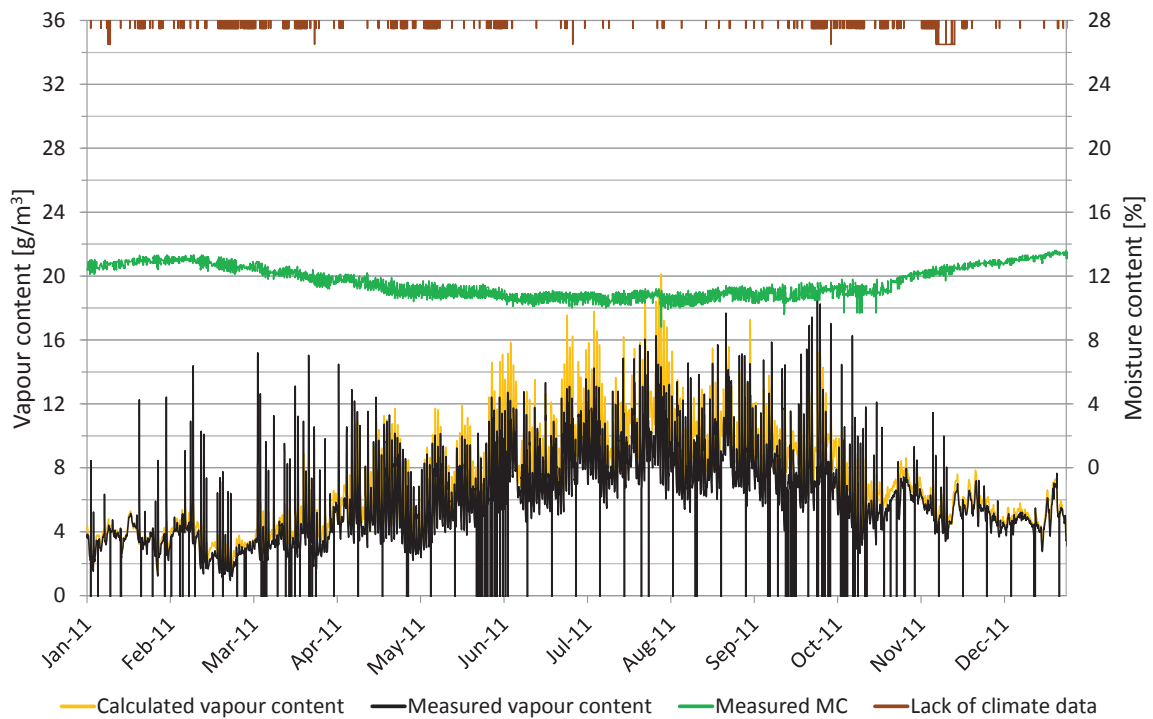

Figure 7.5.16. Measured moisture content, periods lacking climate data and comparisons of vapour content. Vapour content for calculated values (yellow) and measured values (black). Moisture content (green), periods with lack of climate data (brown).



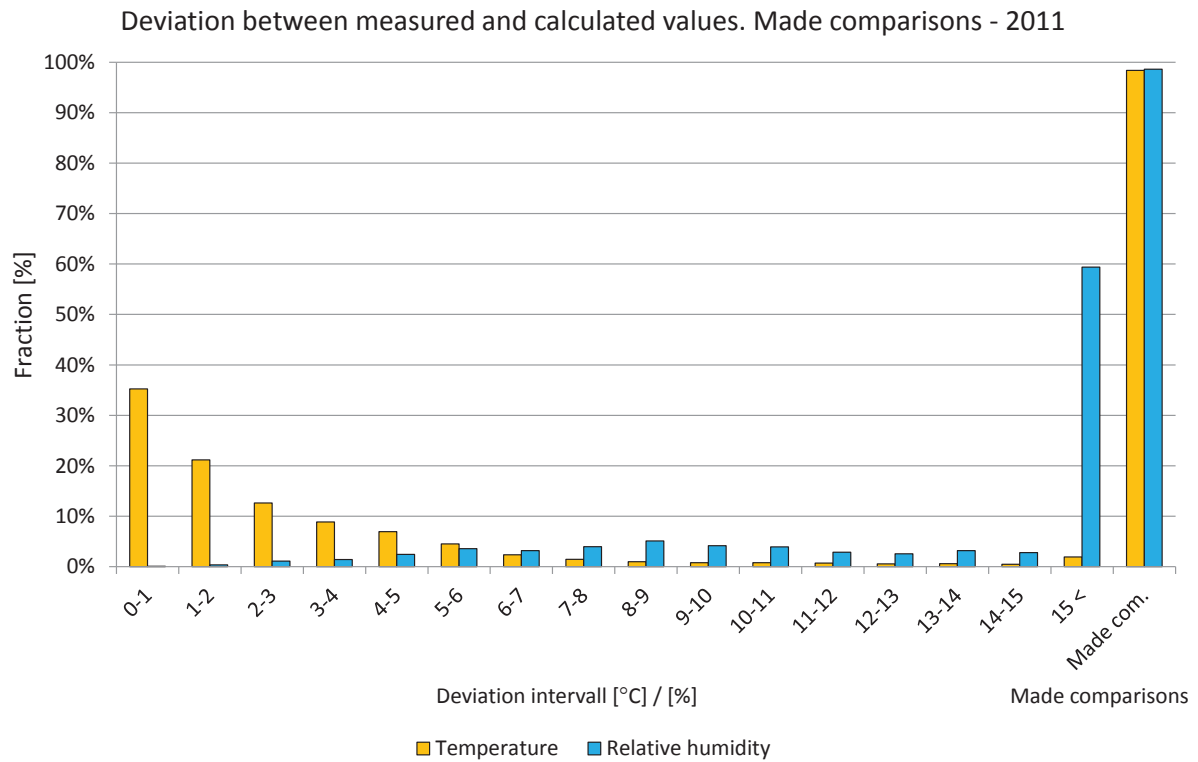

Figure 7.5.17. Deviations in comparisons shown in intervals from 0 to 15 °C or %. The two right-hand bars show the percentage of comparisons during the year. Temperature (yellow) and relative humidity (light blue).



## 7.6 Position 6

The locations of the measured and calculated position are shown in the drawings and figures below. The studied position is located in a wall facing northwest on the first floor.

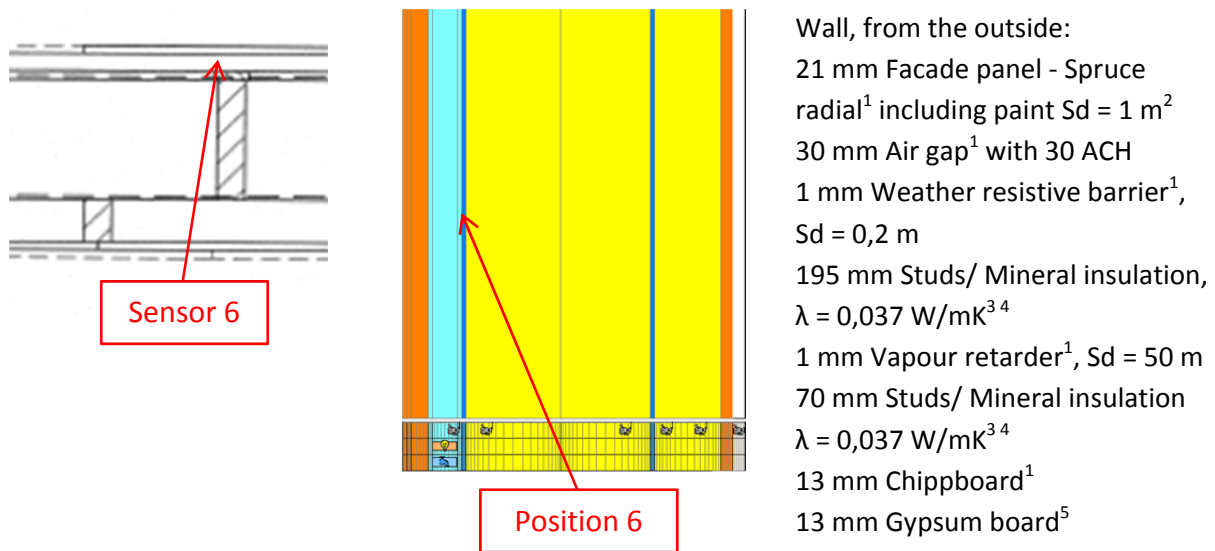

Figure 7.6.1. Vertical cross sectional drawing and WUFI calculation model showing the studied position. 1. IBP, 2012, 2. Nevander, L-E., 1994, 3. IEA Annex 24, 1996, 4. Paroc, 2002, 5. Krus, M., 1996.

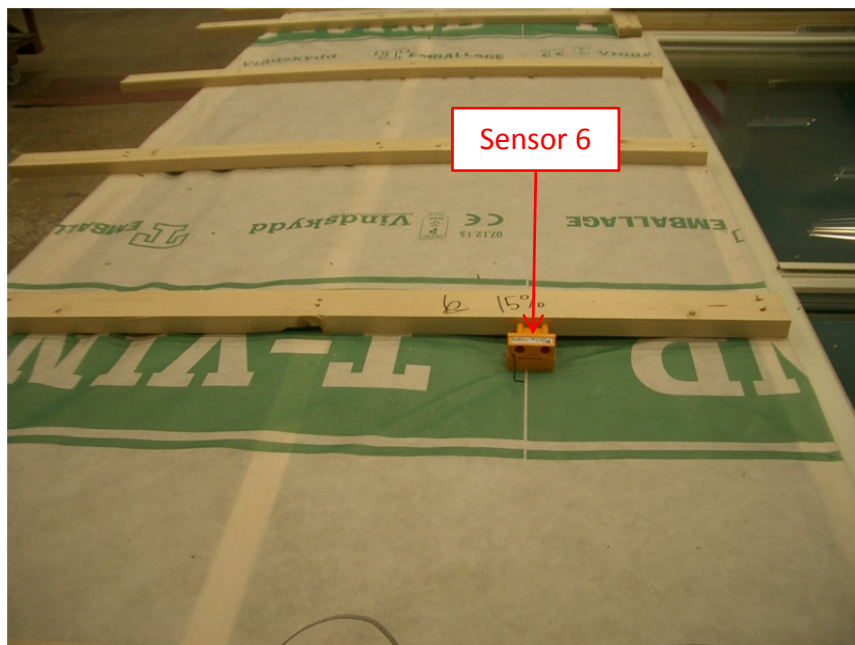

Figure 7.6.2. Location of the studied position.

A perfect match between the measured and calculated values cannot be expected due to e.g. the influence of two- and three-dimensional effects and the accuracy of the sensors.

**Year 2008**

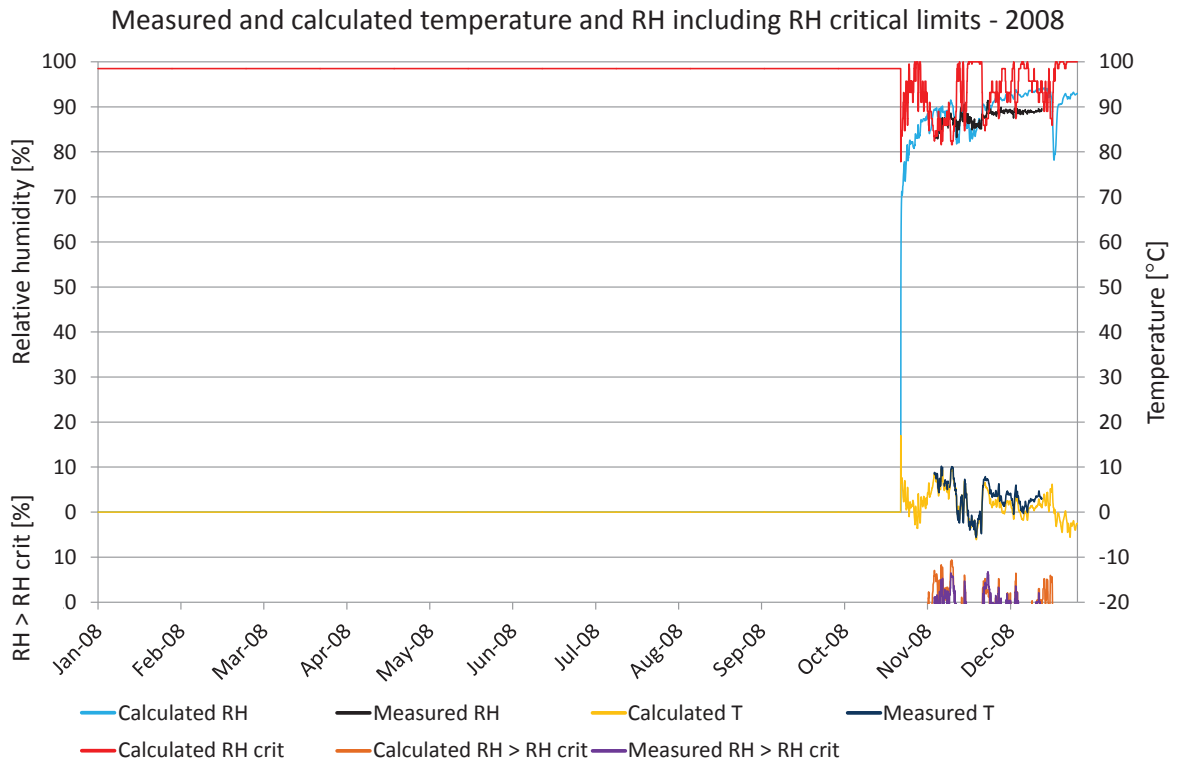

Figure 7.6.3. Comparisons between measured and calculated temperature and relative humidity. Calculated temperature (yellow), measured temperature (dark blue), calculated RH (turquoise), measured RH (black),  $RH_{crit}$  for calculated values (red), calculated  $RH > RH_{crit}$  (light brown), measured  $RH > RH_{crit}$  (purple).

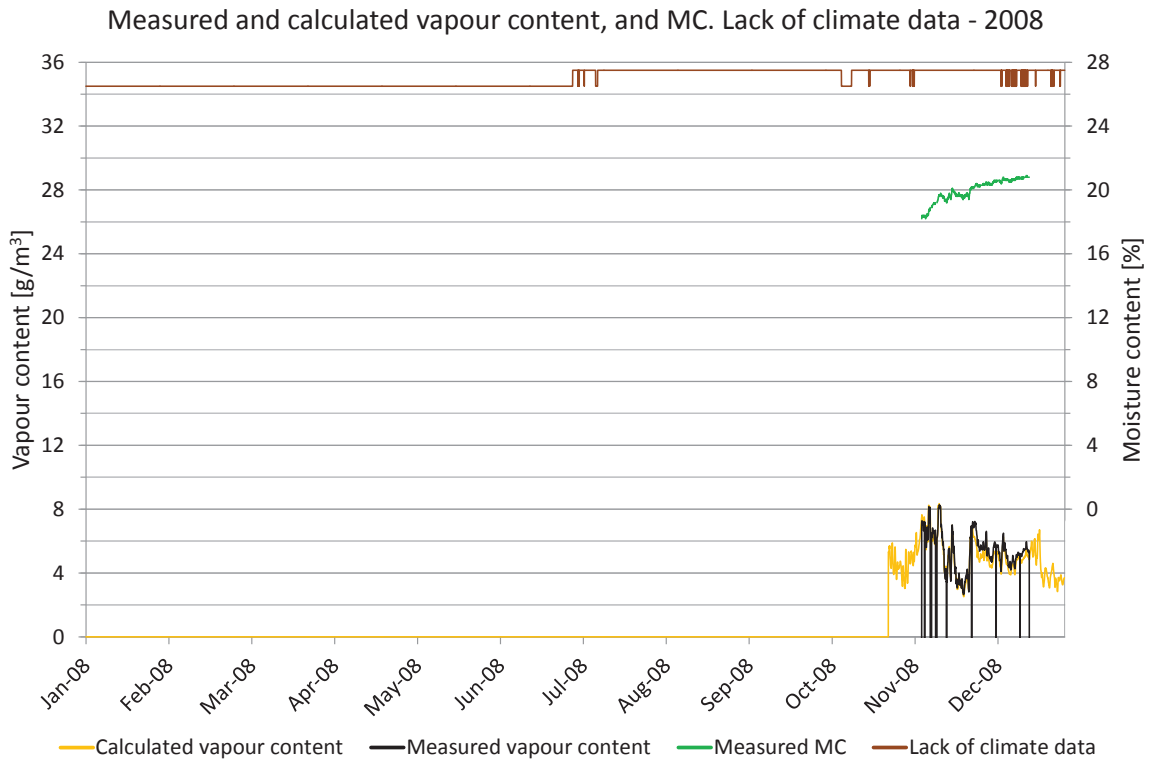

Figure 7.6.4. Measured moisture content, periods lacking climate data and comparisons of vapour content. Vapour content for calculated values (yellow) and measured values (black). Moisture content (green), periods with lack of climate data (brown).

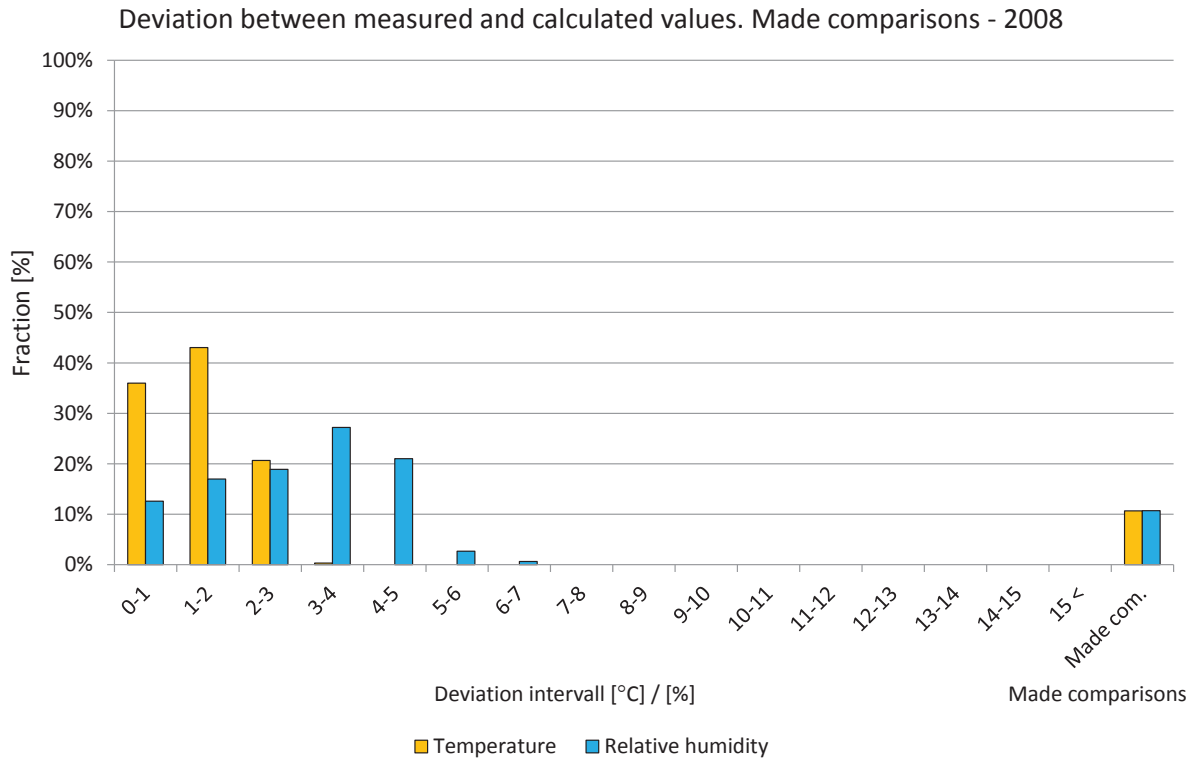

Figure 7.6.5. Deviations in comparisons shown in intervals from 0 to 15 °C or %. The two right-hand bars show the percentage of comparisons during the year. Temperature (yellow) and relative humidity (light blue).

**Year 2009**

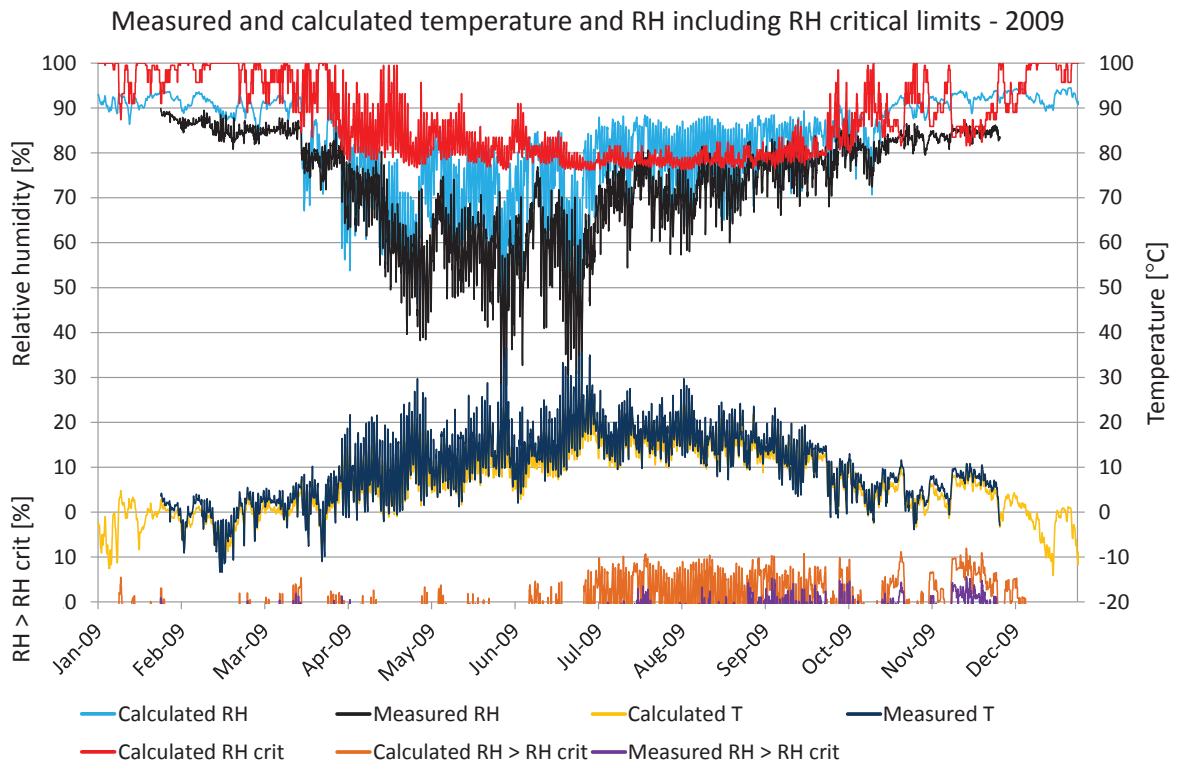

Figure 7.6.6. Comparisons between measured and calculated temperature and relative humidity. Calculated temperature (yellow), measured temperature (dark blue), calculated RH (turquoise), measured RH (black),  $RH_{crit}$  for calculated values (red), calculated  $RH > RH_{crit}$  (light brown), measured  $RH > RH_{crit}$  (purple).

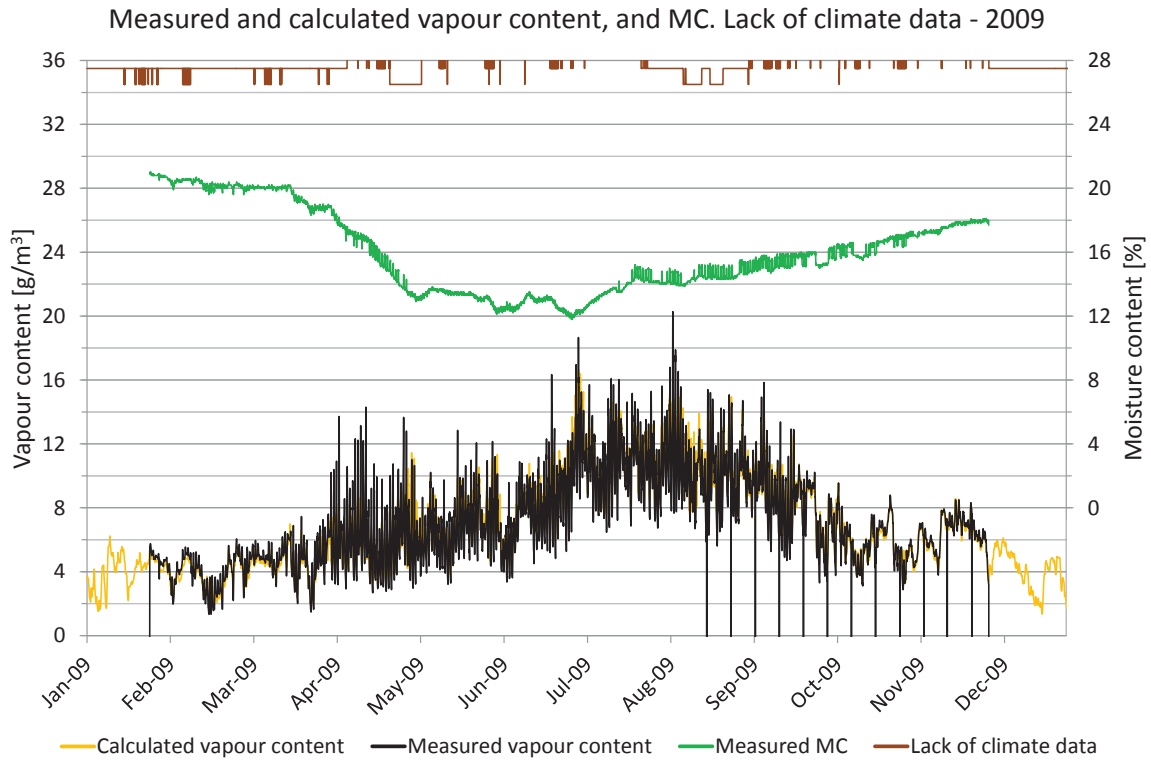

Figure 7.6.7. Measured moisture content, periods lacking climate data and comparisons of vapour content. Vapour content for calculated values (yellow) and measured values (black). Moisture content (green), periods with lack of climate data (brown).

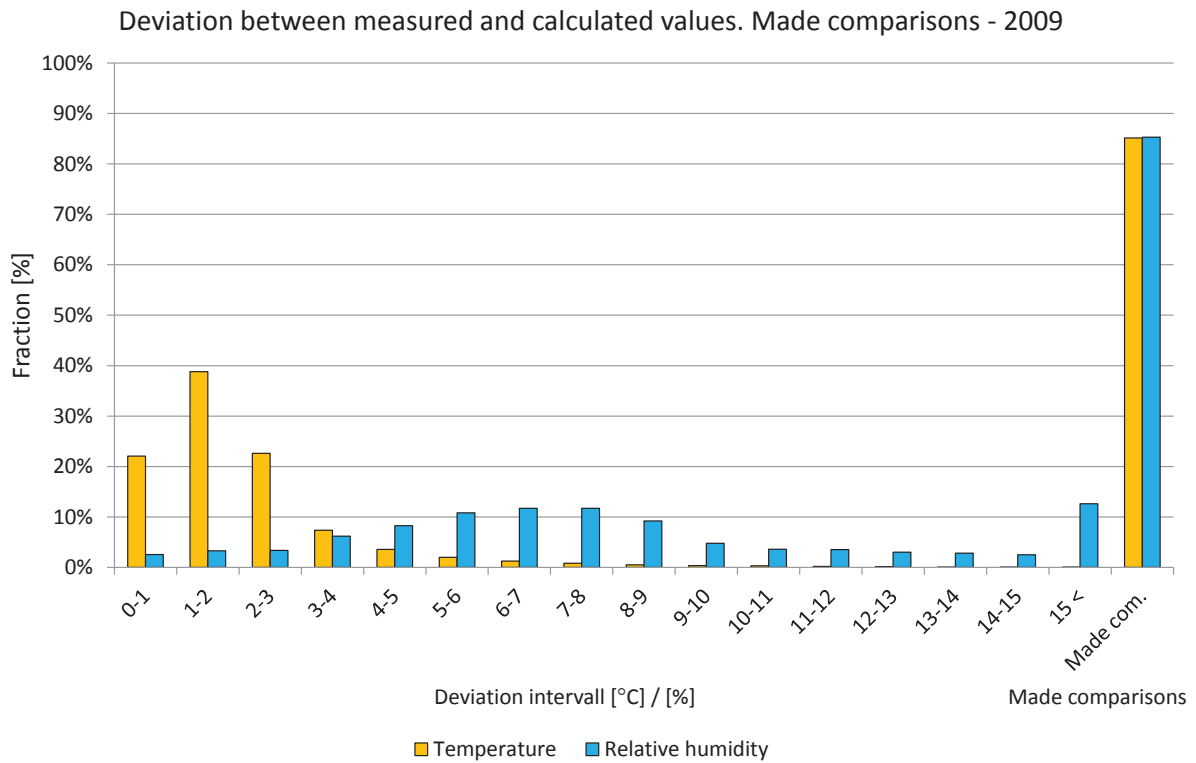

Figure 7.6.8. Deviations in comparisons shown in intervals from 0 to 15 °C or %. The two right-hand bars show the percentage of comparisons during the year. Temperature (yellow) and relative humidity (light blue).

**Year 2010**

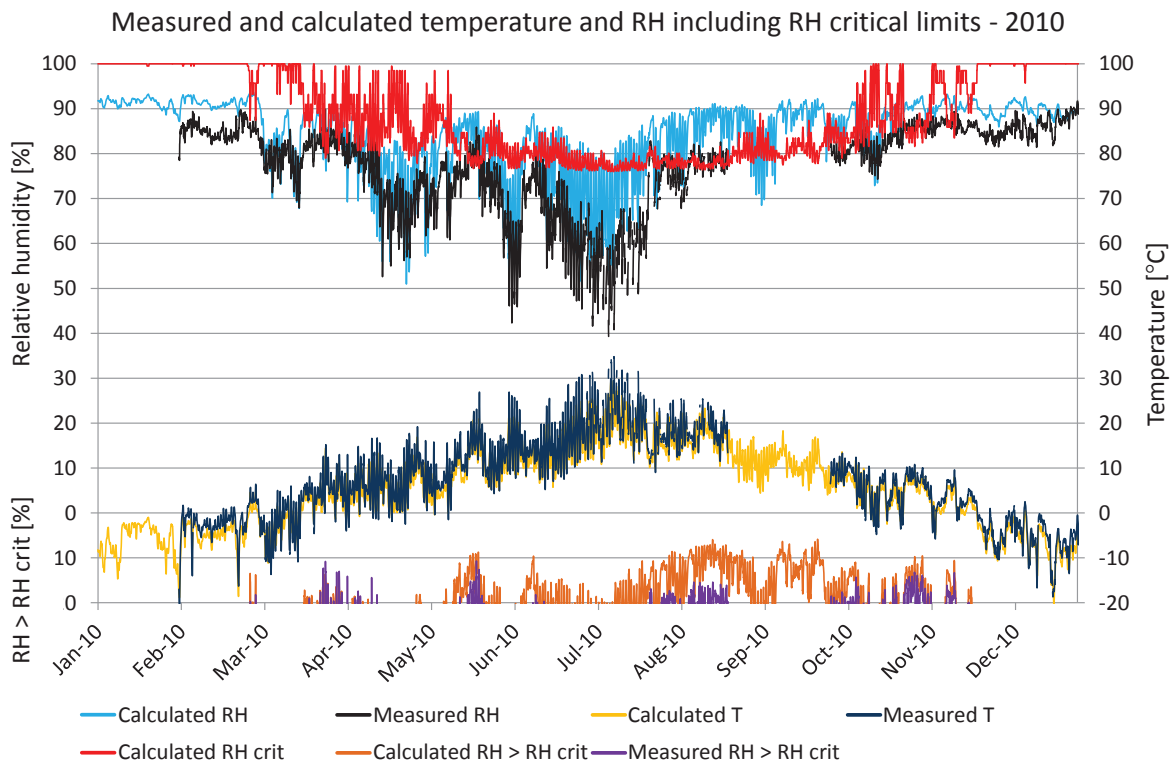

Figure 7.6.9. Comparisons between measured and calculated temperature and relative humidity. Calculated temperature (yellow), measured temperature (dark blue), calculated RH (turquoise), measured RH (black),  $RH_{crit}$  for calculated values (red), calculated  $RH > RH_{crit}$  (light brown), measured  $RH > RH_{crit}$  (purple).

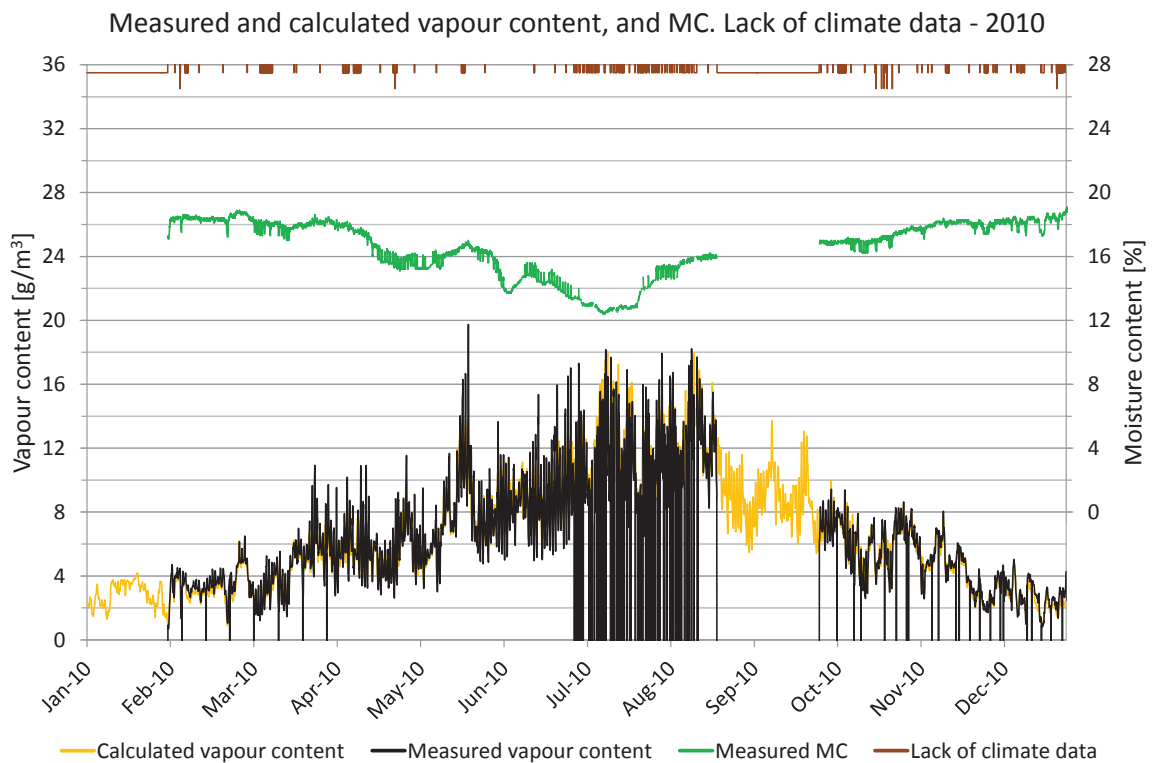

Figure 7.6.10. Measured moisture content, periods lacking climate data and comparisons of vapour content. Vapour content for calculated values (yellow) and measured values (black). Moisture content (green), periods with lack of climate data (brown).

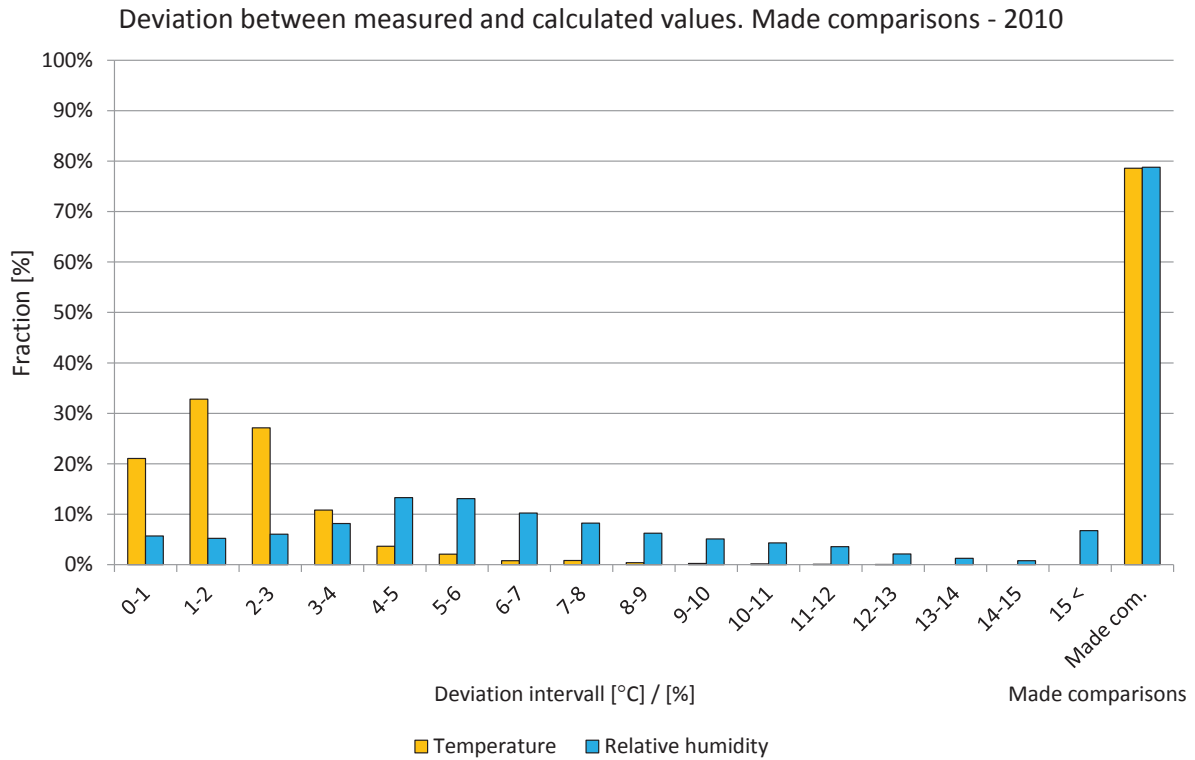

Figure 7.6.11. Deviations in comparisons shown in intervals from 0 to 15 °C or %. The two right-hand bars show the percentage of comparisons during the year. Temperature (yellow) and relative humidity (light blue).

**Year 2011**

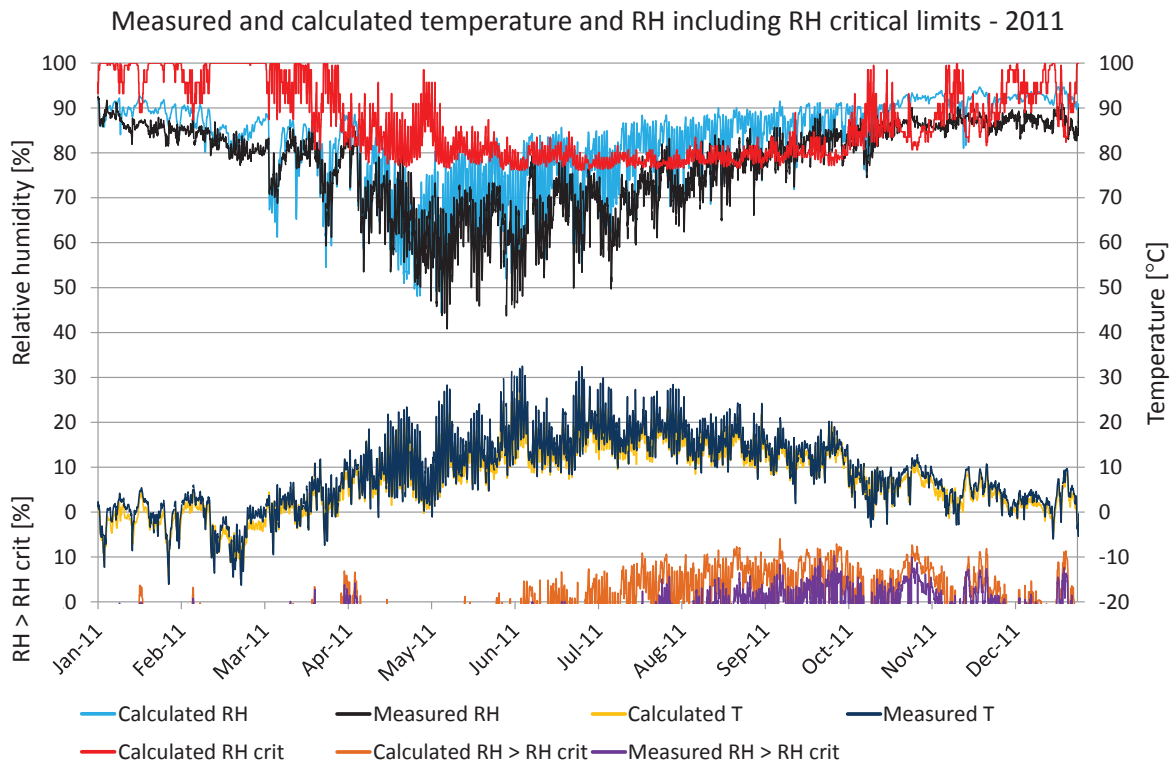

Figure 7.6.12. Comparisons between measured and calculated temperature and relative humidity. Calculated temperature (yellow), measured temperature (dark blue), calculated RH (turquoise), measured RH (black),  $RH_{crit}$  for calculated values (red), calculated  $RH > RH_{crit}$  (light brown), measured  $RH > RH_{crit}$  (purple).



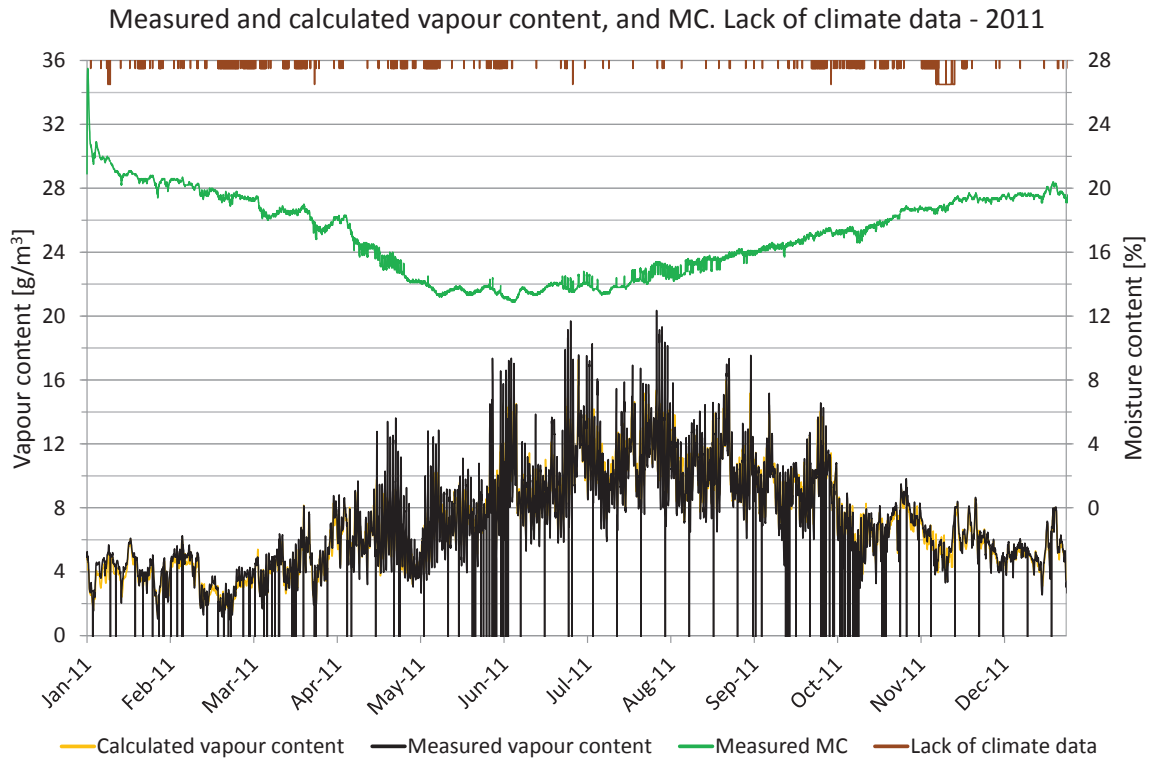

Figure 7.6.13. Measured moisture content, periods lacking climate data and comparisons of vapour content. Vapour content for calculated values (yellow) and measured values (black). Moisture content (green), periods with lack of climate data (brown).

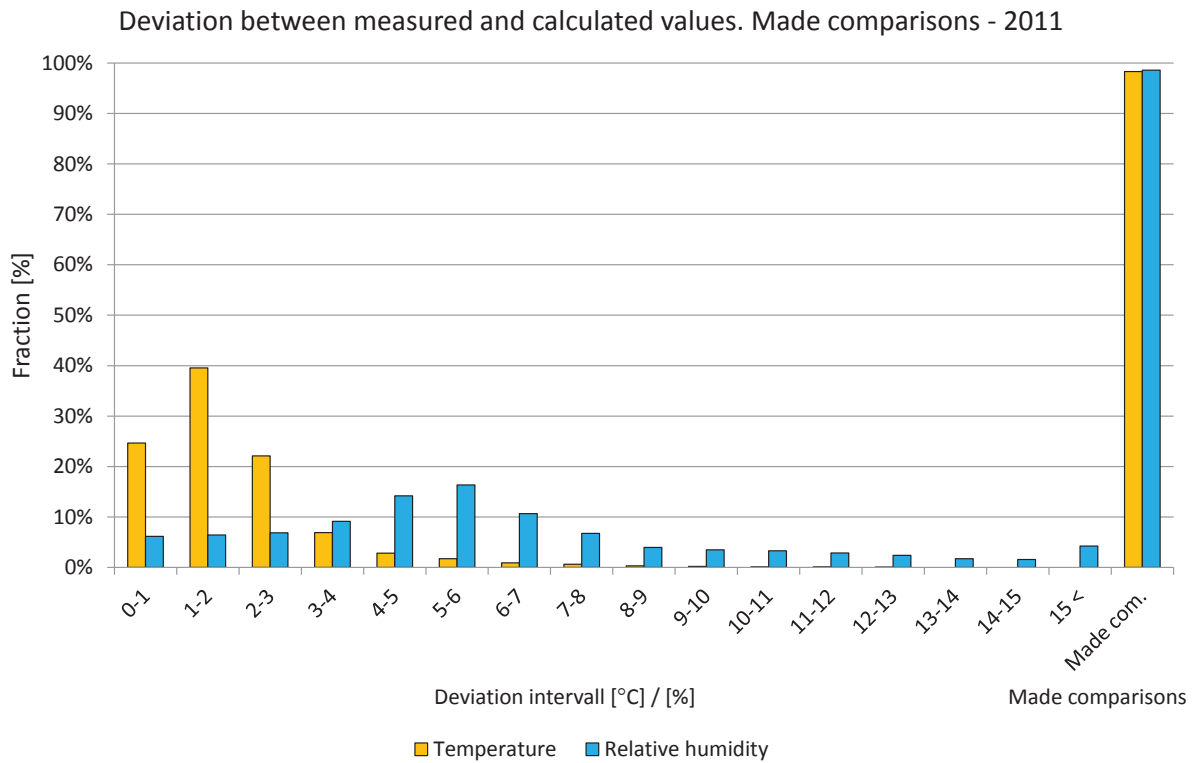

Figure 7.6.14. Deviations in comparisons shown in intervals from 0 to 15 °C or %. The two right-hand bars show the percentage of comparisons during the year. Temperature (yellow) and relative humidity (light blue).



## 7.7 Position 7

The locations of the measured and calculated position are shown in the drawings and figures below. The studied position is located in a wall facing northwest on the first floor.

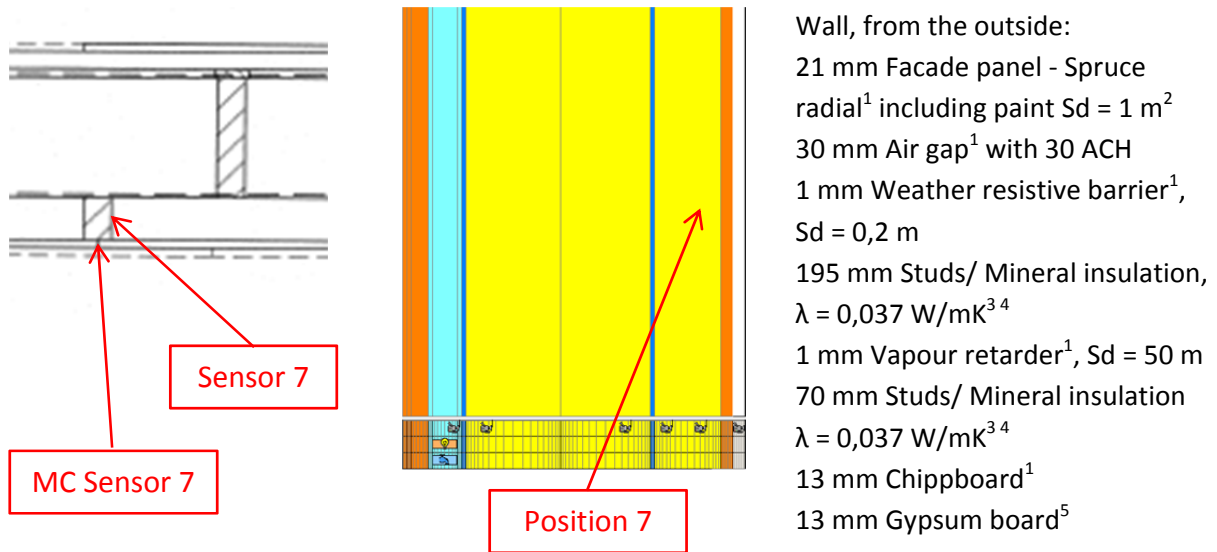

Figure 7.7.1. Vertical cross sectional drawing and WUFI calculation model showing the studied position. 1. IBP, 2012, 2. Nevander, L-E., 1994, 3. IEA Annex 24, 1996, 4. Paroc, 2002, 5. Krus, M., 1996.

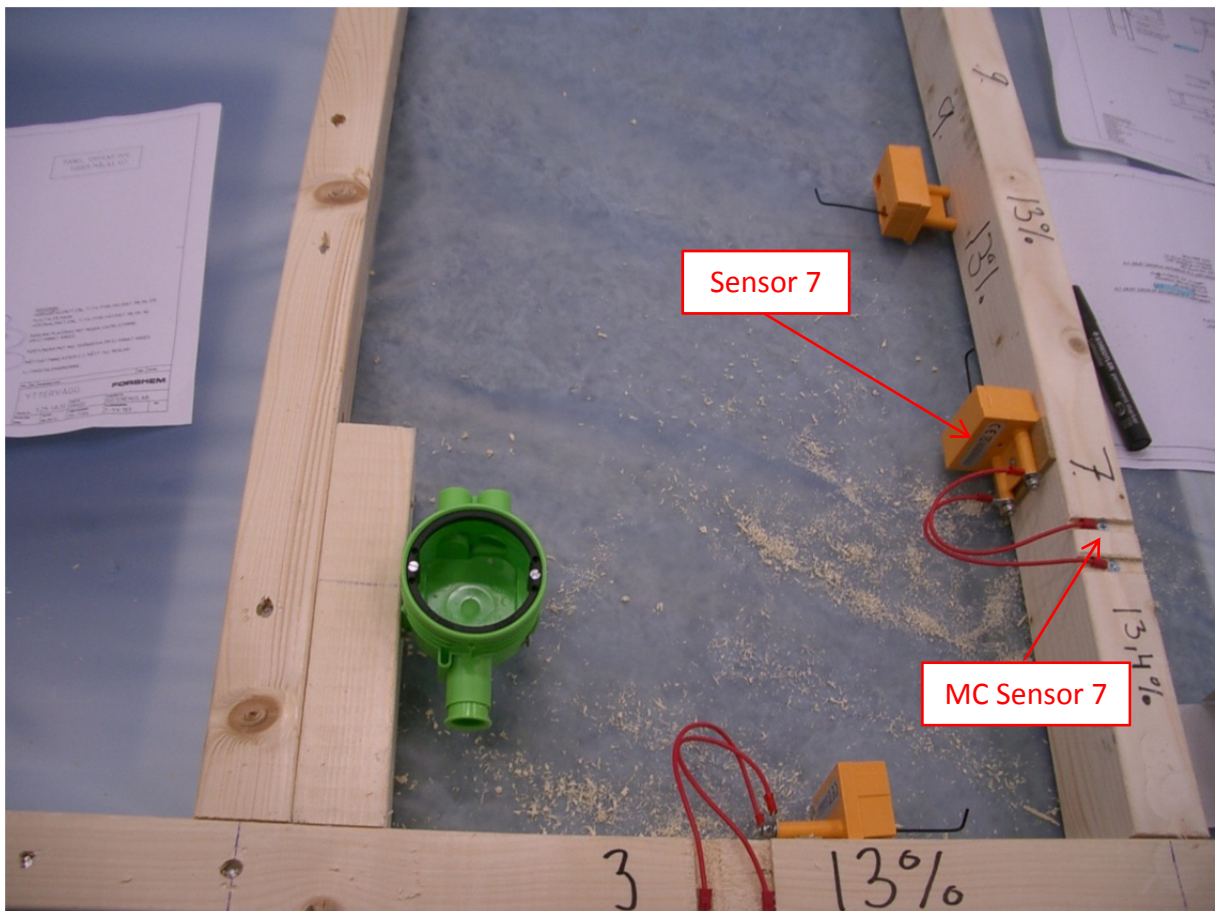

Figure 7.7.2. Location of the studied position. Photo: Götenehus AB.

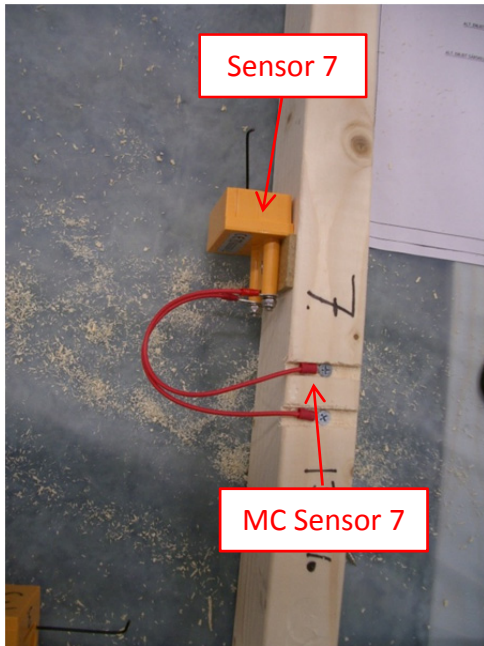

Figure 7.7.3. Location of the studied position.

A perfect match between the measured and calculated values cannot be expected due to e.g. the influence of two- and three-dimensional effects and the accuracy of the sensors.

### Year 2008

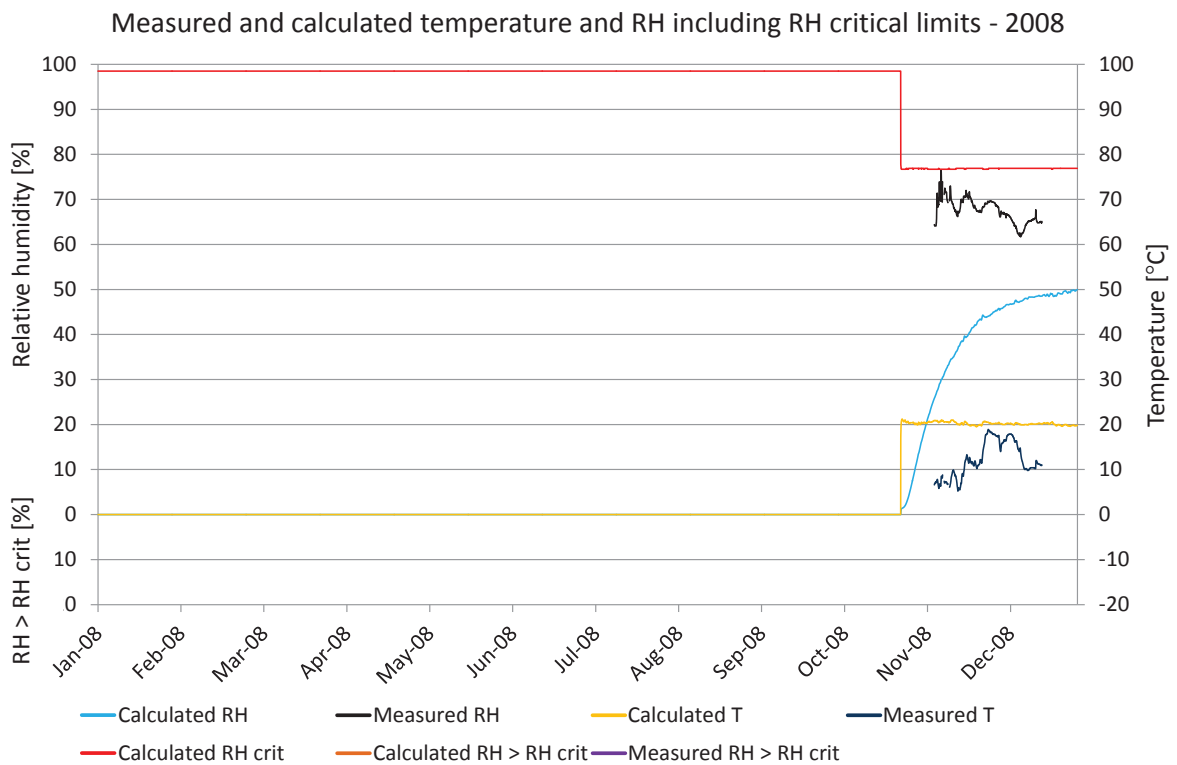

Figure 7.7.4. Comparisons between measured and calculated temperature and relative humidity. Calculated temperature (yellow), measured temperature (dark blue), calculated RH (turquoise), measured RH (black),  $RH_{crit}$  for calculated values (red), calculated  $RH > RH_{crit}$  (light brown), measured  $RH > RH_{crit}$  (purple).

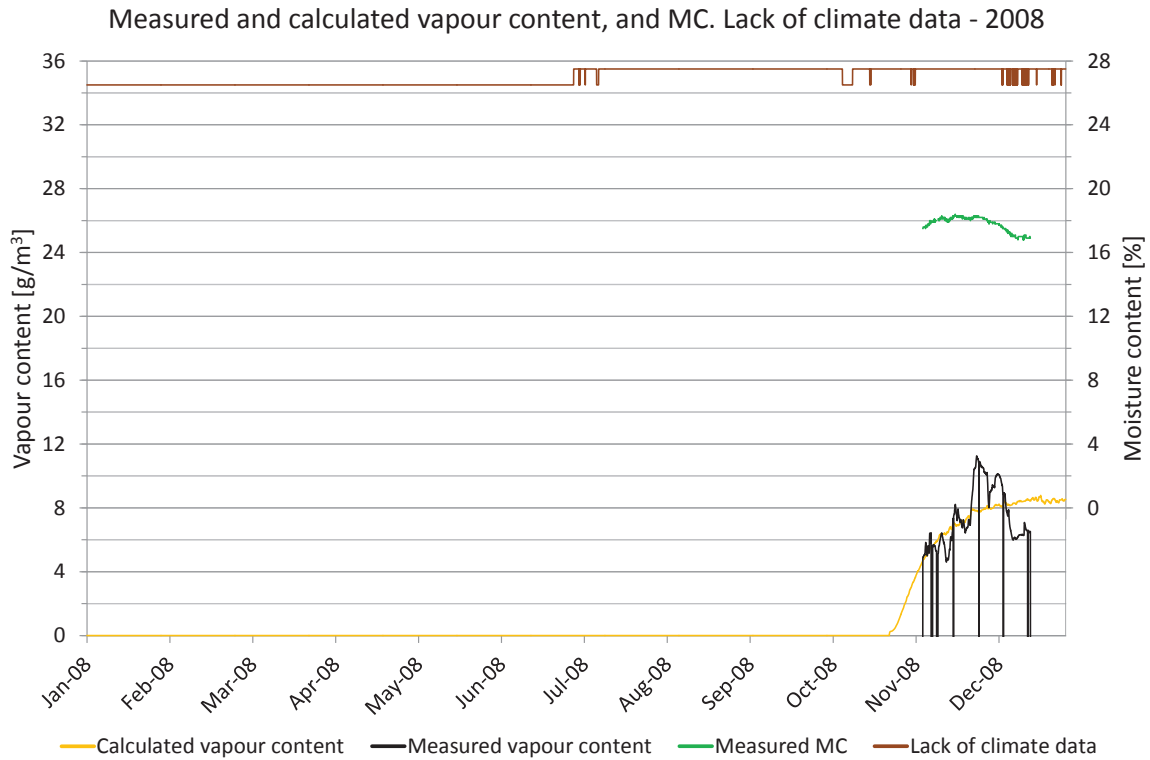

Figure 7.7.5. Measured moisture content, periods lacking climate data and comparisons of vapour content. Vapour content for calculated values (yellow) and measured values (black). Moisture content (green), periods with lack of climate data (brown).

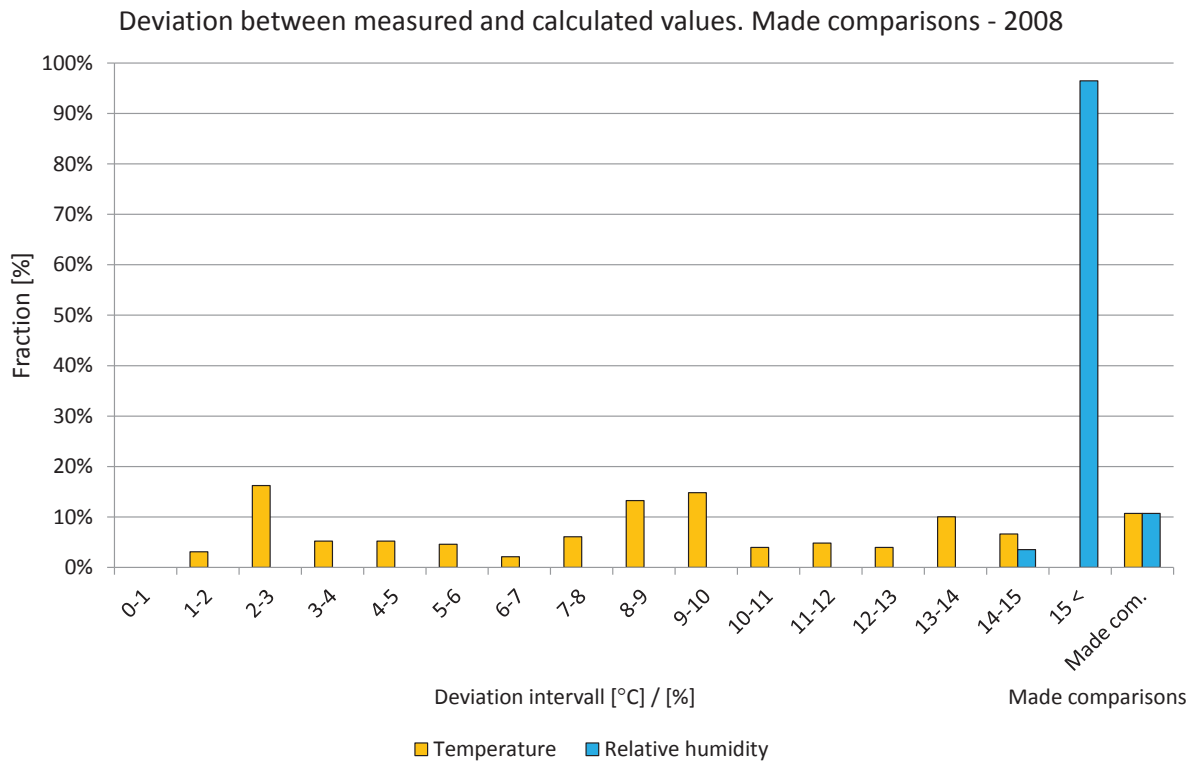

Figure 7.7.6. Deviations in comparisons shown in intervals from 0 to 15 °C or %. The two right-hand bars show the percentage of comparisons during the year. Temperature (yellow) and relative humidity (light blue).

**Year 2009**

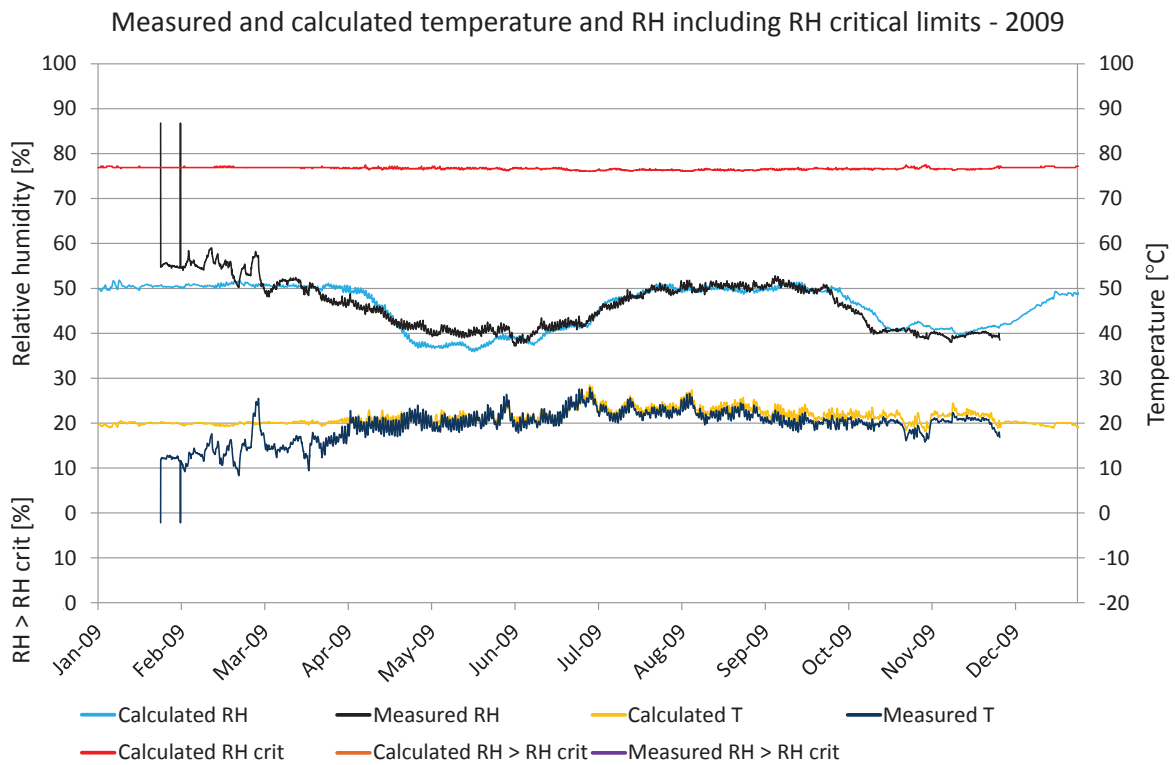

Figure 7.7.7. Comparisons between measured and calculated temperature and relative humidity. Calculated temperature (yellow), measured temperature (dark blue), calculated RH (turquoise), measured RH (black),  $RH_{crit}$  for calculated values (red), calculated  $RH > RH_{crit}$  (light brown), measured  $RH > RH_{crit}$  (purple).

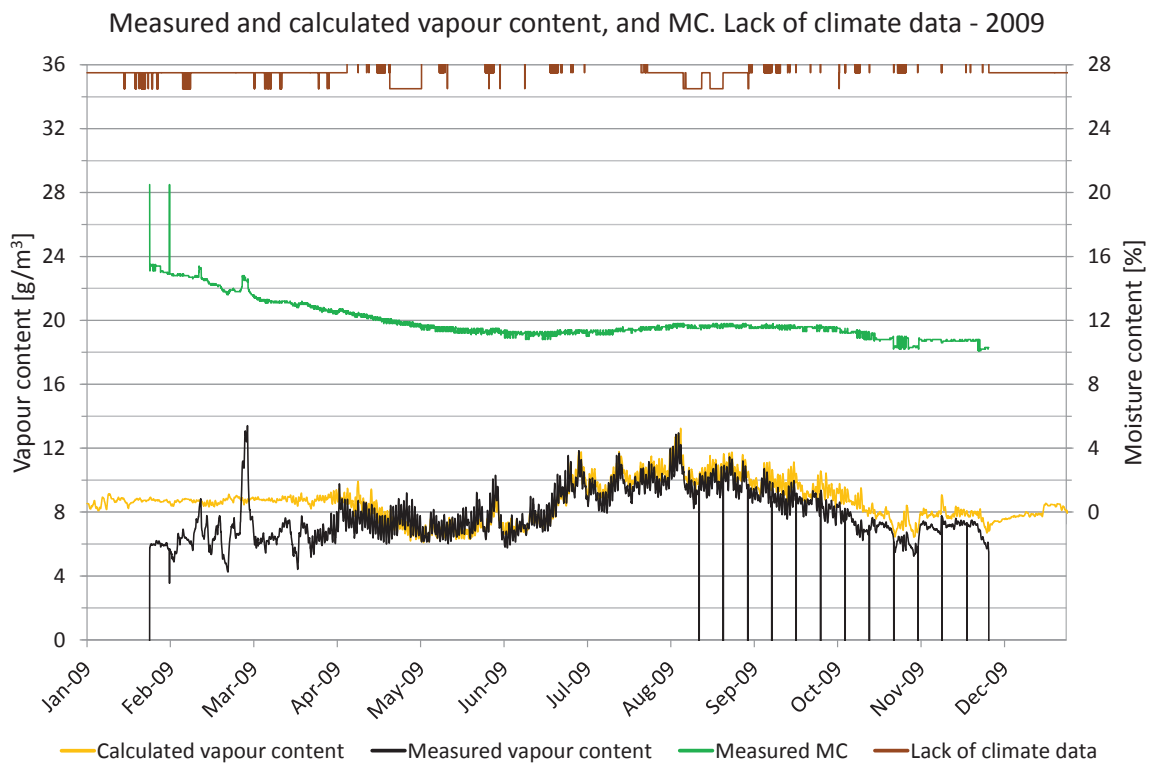

Figure 7.7.8. Measured moisture content, periods lacking climate data and comparisons of vapour content. Vapour content for calculated values (yellow) and measured values (black). Moisture content (green), periods with lack of climate data (brown).

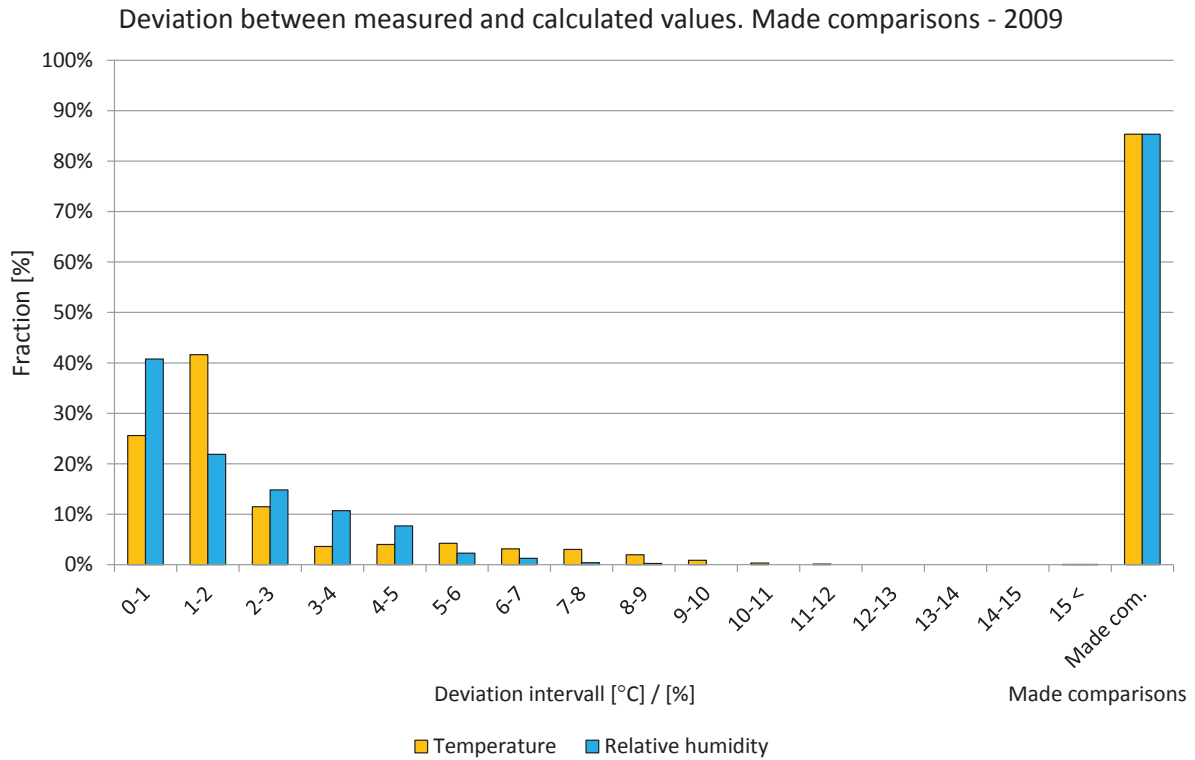

Figure 7.7.9. Deviations in comparisons shown in intervals from 0 to 15 °C or %. The two right-hand bars show the percentage of comparisons during the year. Temperature (yellow) and relative humidity (light blue).

**Year 2010**

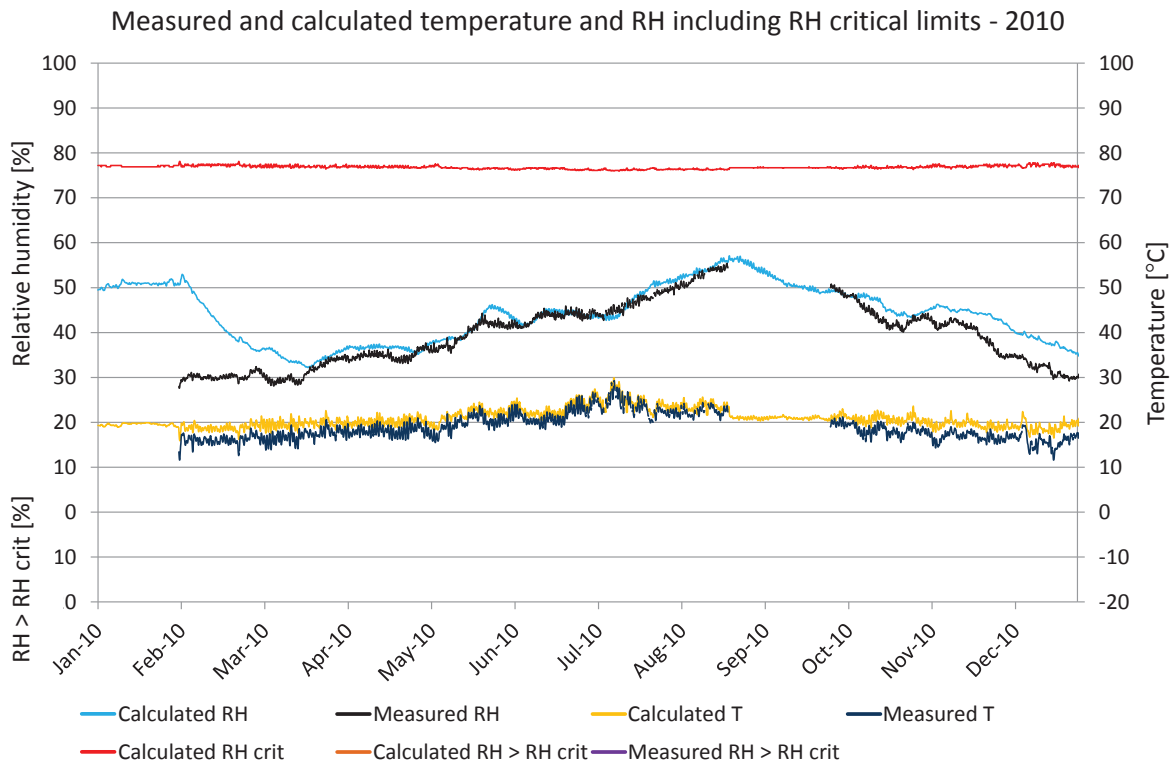

Figure 7.7.10. Comparisons between measured and calculated temperature and relative humidity. Calculated temperature (yellow), measured temperature (dark blue), calculated RH (turquoise), measured RH (black),  $RH_{crit}$  for calculated values (red), calculated  $RH > RH_{crit}$  (light brown), measured  $RH > RH_{crit}$  (purple).

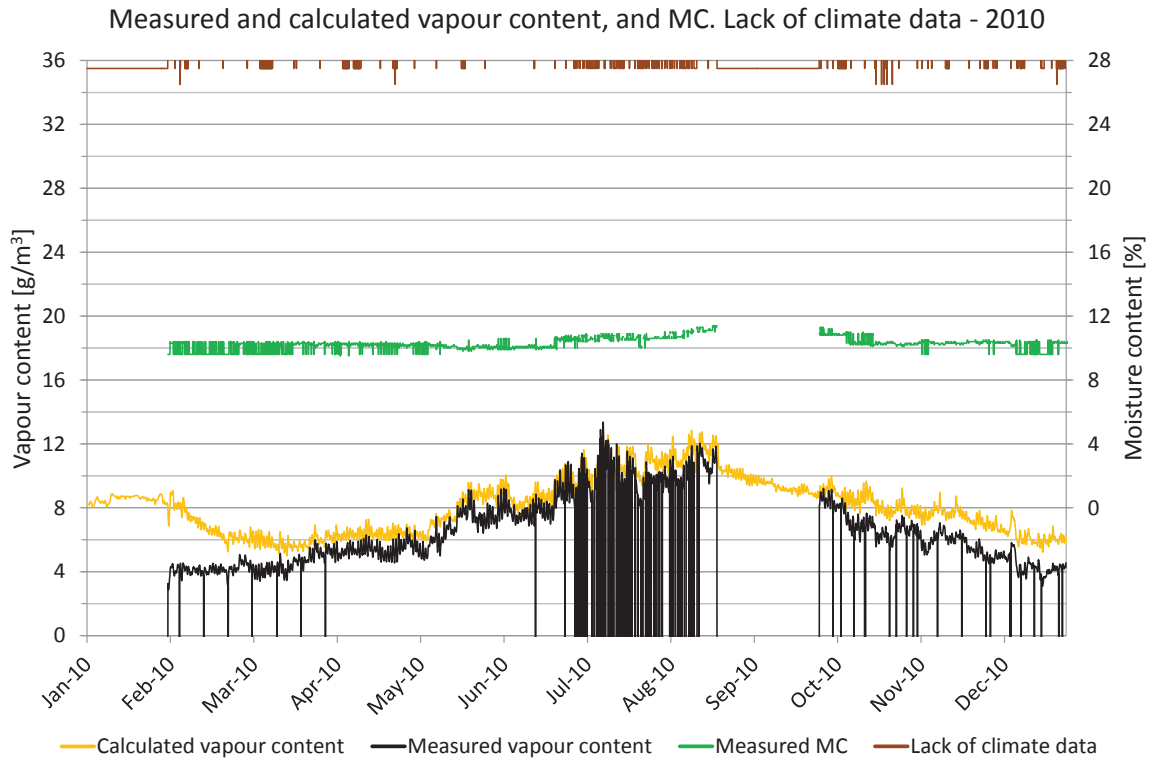

Figure 7.7.11. Measured moisture content, periods lacking climate data and comparisons of vapour content. Vapour content for calculated values (yellow) and measured values (black). Moisture content (green), periods with lack of climate data (brown).

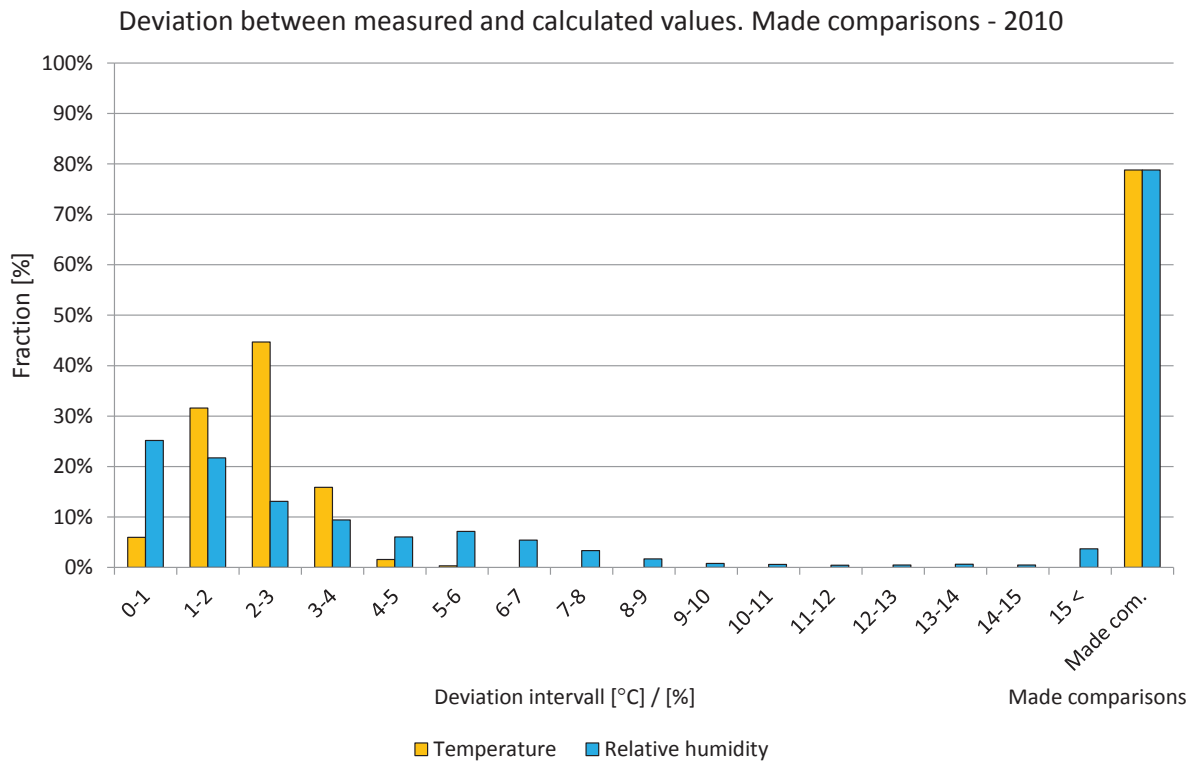

Figure 7.7.12. Deviations in comparisons shown in intervals from 0 to 15 °C or %. The two right-hand bars show the percentage of comparisons during the year. Temperature (yellow) and relative humidity (light blue).



**Year 2011**

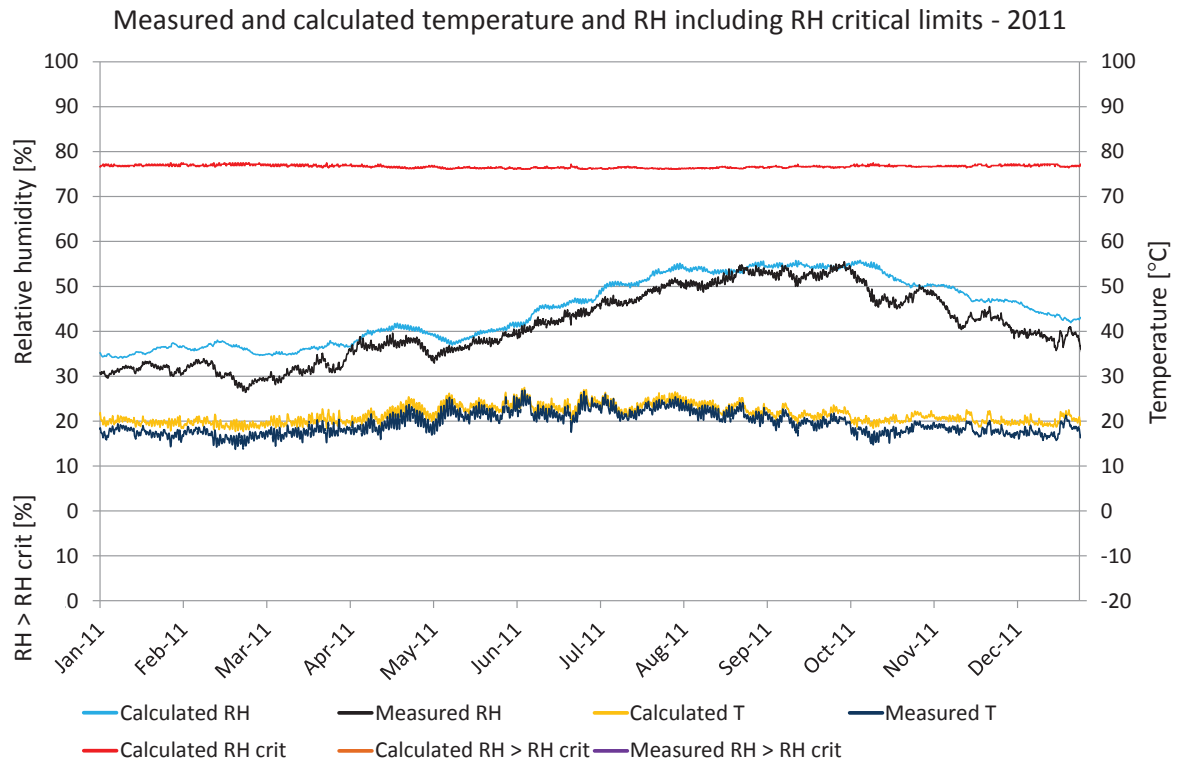

Figure 7.7.13. Comparisons between measured and calculated temperature and relative humidity. Calculated temperature (yellow), measured temperature (dark blue), calculated RH (turquoise), measured RH (black),  $RH_{crit}$  for calculated values (red), calculated  $RH > RH_{crit}$  (light brown), measured  $RH > RH_{crit}$  (purple).

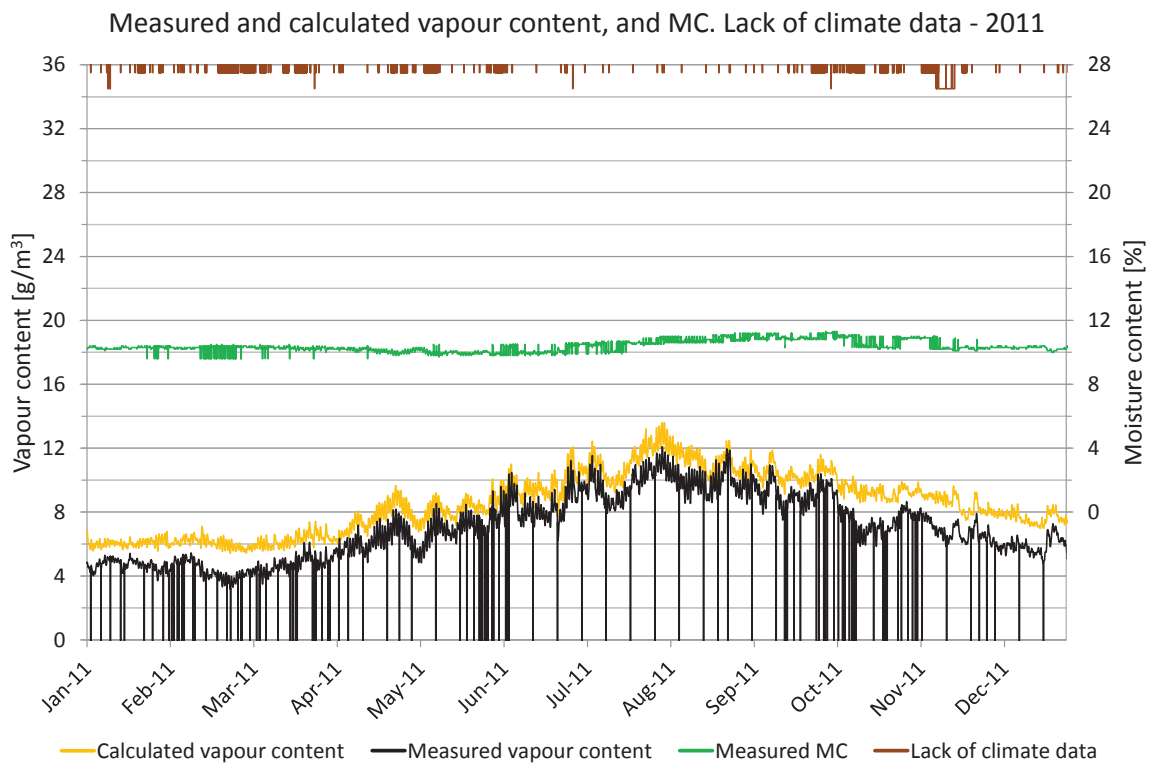

Figure 7.7.14. Measured moisture content, periods lacking climate data and comparisons of vapour content. Vapour content for calculated values (yellow) and measured values (black). Moisture content (green), periods with lack of climate data (brown).

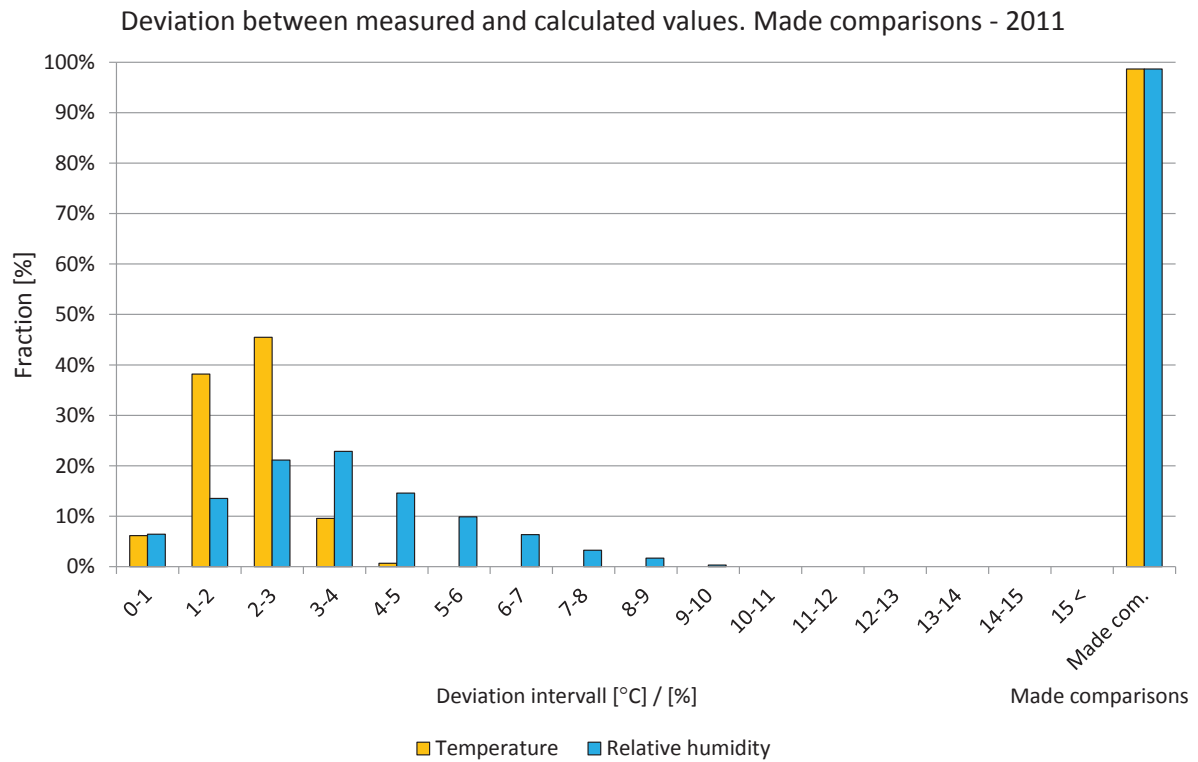

Figure 7.7.15. Deviations in comparisons shown in intervals from 0 to 15 °C or %. The two right-hand bars show the percentage of comparisons during the year. Temperature (yellow) and relative humidity (light blue).

## 7.8 Position 8

The locations of the measured and calculated position are shown in the drawings and figures below. The studied position is located in a wall facing northwest on the first floor.

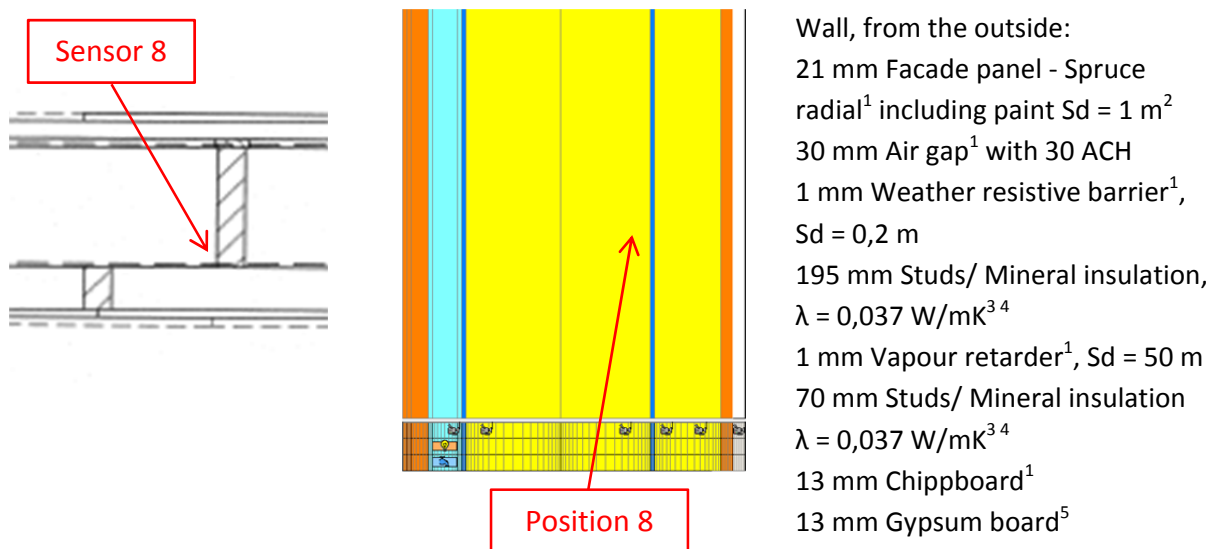

Figure 7.8.1. Vertical cross sectional drawing and WUFI calculation model showing the studied position. 1. IBP, 2012, 2. Nevander, L-E., 1994, 3. IEA Annex 24, 1996, 4. Paroc, 2002, 5. Krus, M., 1996.



Figure 7.8.2. Location of the studied position.

A perfect match between the measured and calculated values cannot be expected due to e.g. the influence of two- and three-dimensional effects and the accuracy of the sensors.

**Year 2008**

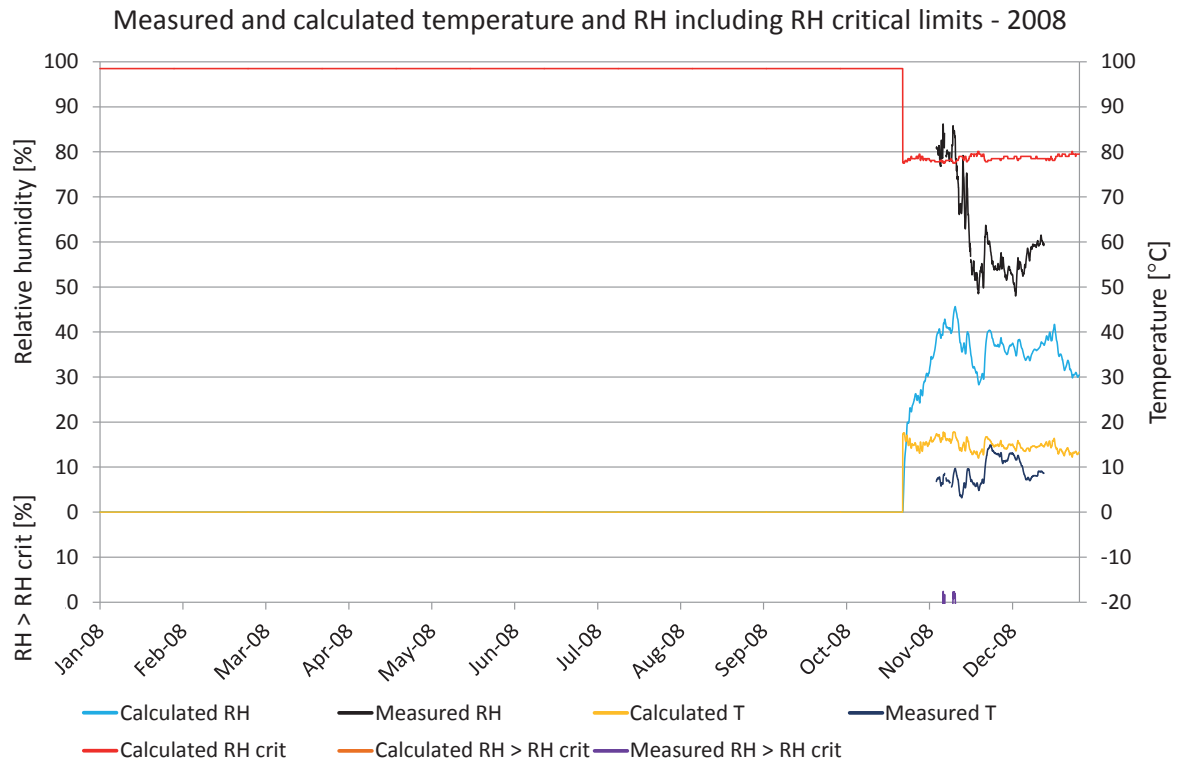

Figure 7.8.3. Comparisons between measured and calculated temperature and relative humidity. Calculated temperature (yellow), measured temperature (dark blue), calculated RH (turquoise), measured RH (black),  $RH_{crit}$  for calculated values (red), calculated  $RH > RH_{crit}$  (light brown), measured  $RH > RH_{crit}$  (purple).

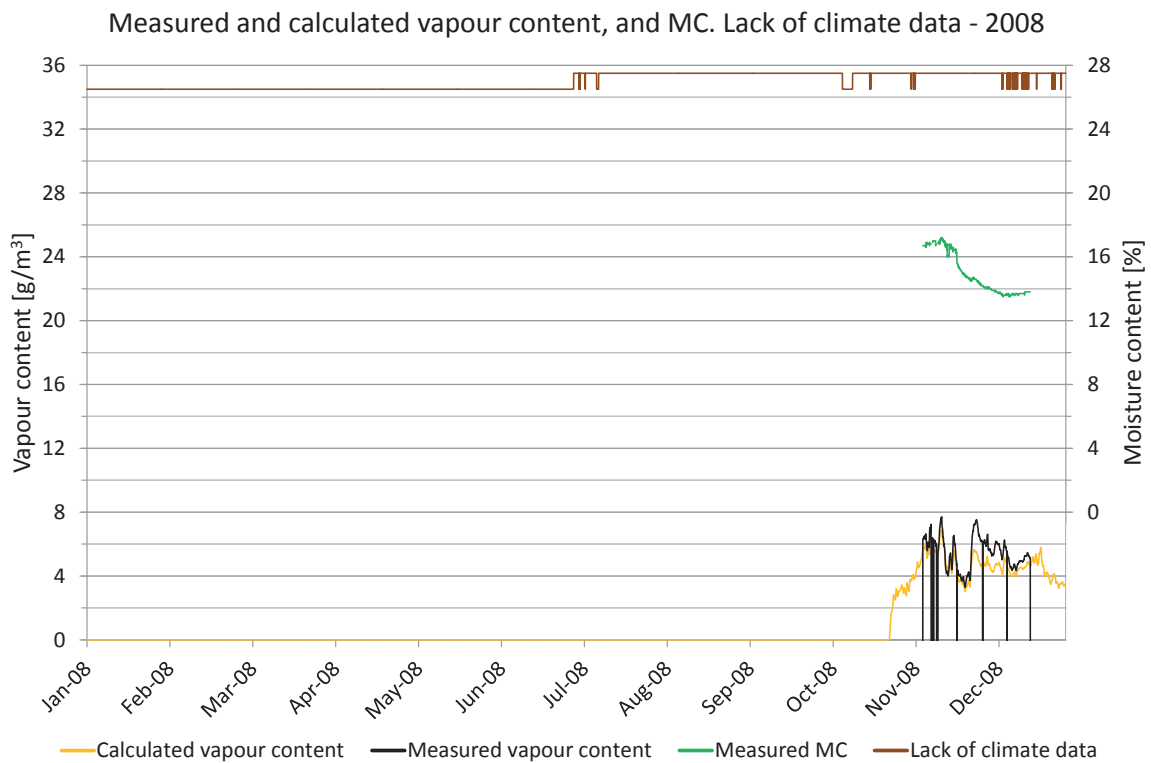

Figure 7.8.4. Measured moisture content, periods lacking climate data and comparisons of vapour content. Vapour content for calculated values (yellow) and measured values (black). Moisture content (green), periods with lack of climate data (brown).

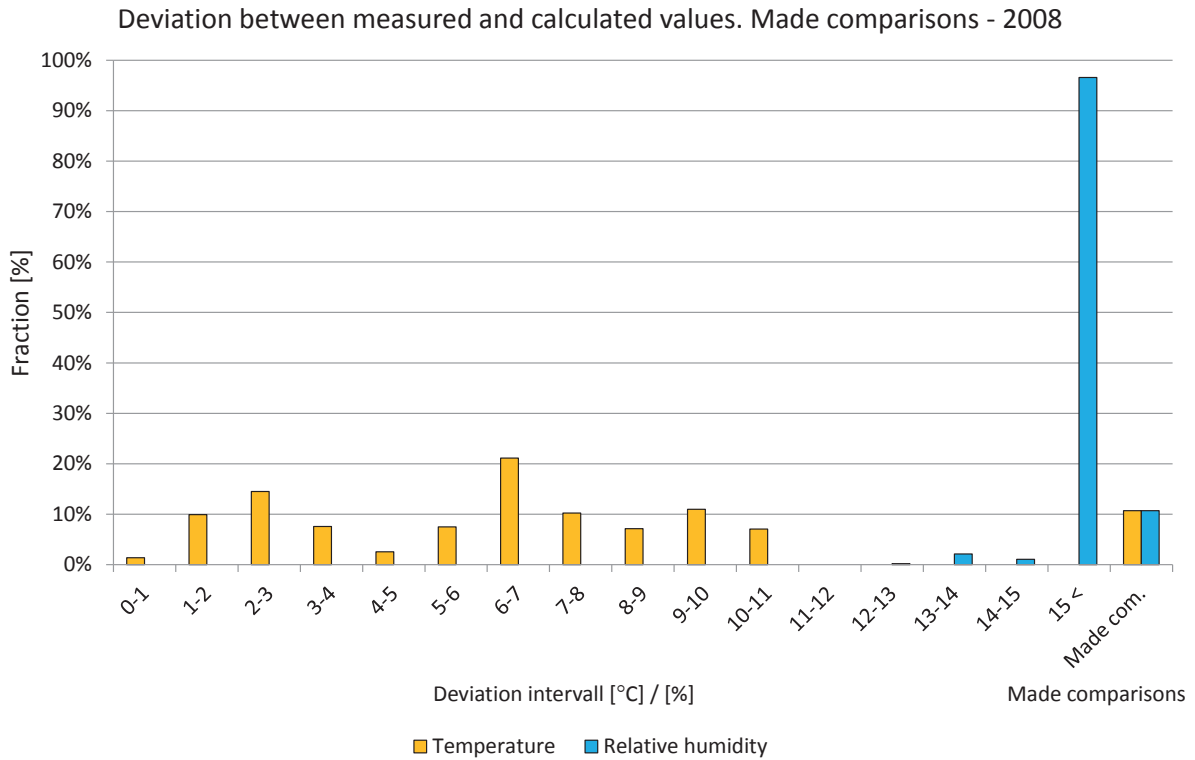

Figure 7.8.5. Deviations in comparisons shown in intervals from 0 to 15 °C or %. The two right-hand bars show the percentage of comparisons during the year. Temperature (yellow) and relative humidity (light blue).

**Year 2009**

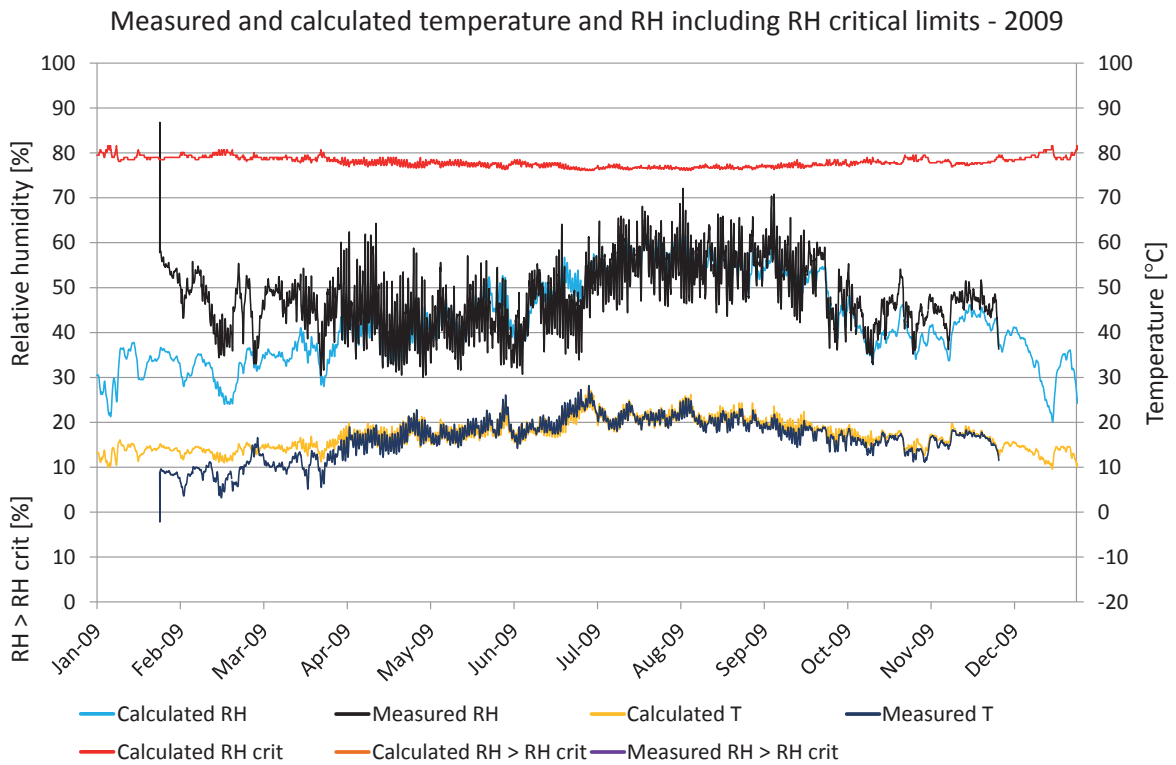

Figure 7.8.6. Comparisons between measured and calculated temperature and relative humidity. Calculated temperature (yellow), measured temperature (dark blue), calculated RH (turquoise), measured RH (black),  $RH_{crit}$  for calculated values (red), calculated  $RH > RH_{crit}$  (light brown), measured  $RH > RH_{crit}$  (purple).

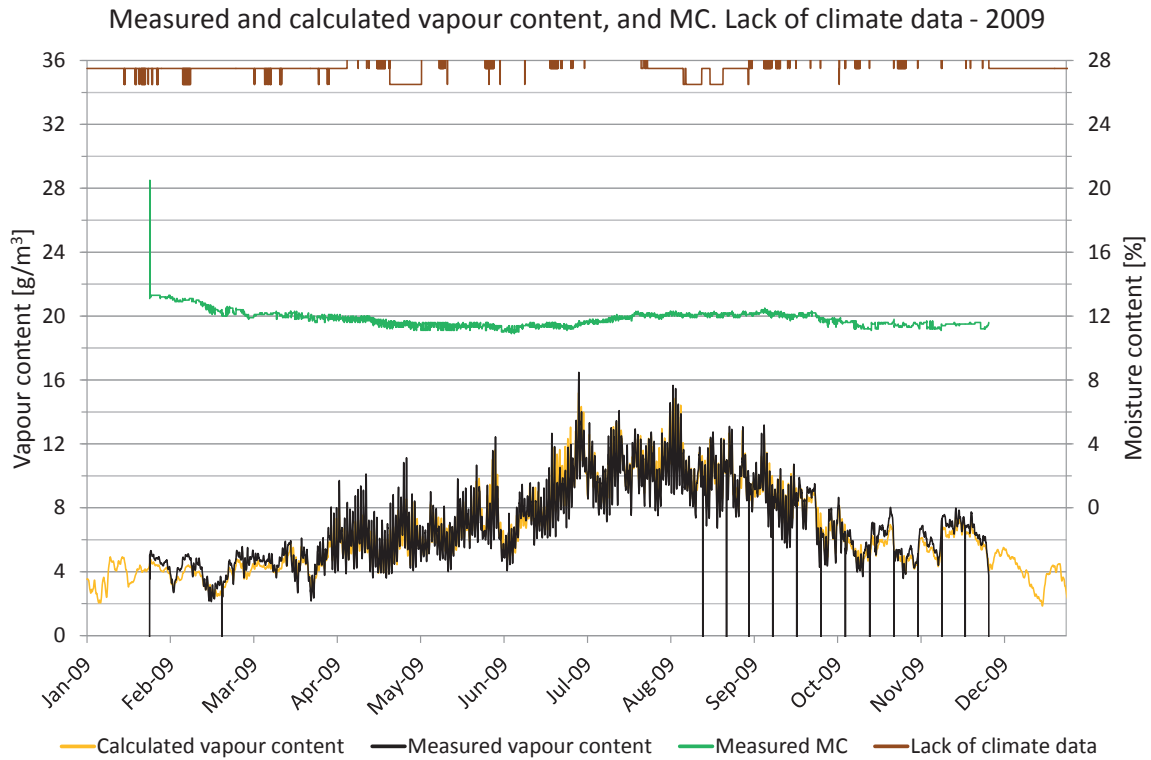

Figure 7.8.7. Measured moisture content, periods lacking climate data and comparisons of vapour content. Vapour content for calculated values (yellow) and measured values (black). Moisture content (green), periods with lack of climate data (brown).

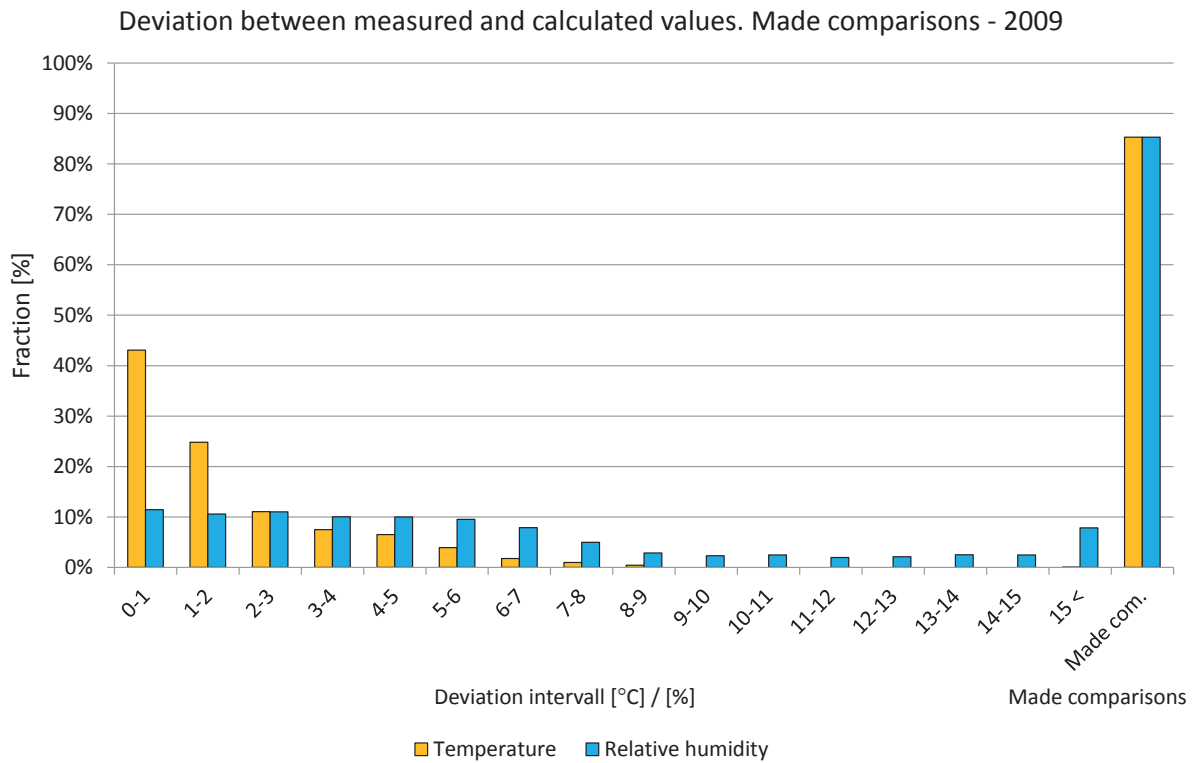

Figure 7.8.8. Deviations in comparisons shown in intervals from 0 to 15 °C or %. The two right-hand bars show the percentage of comparisons during the year. Temperature (yellow) and relative humidity (light blue).

**Year 2010**

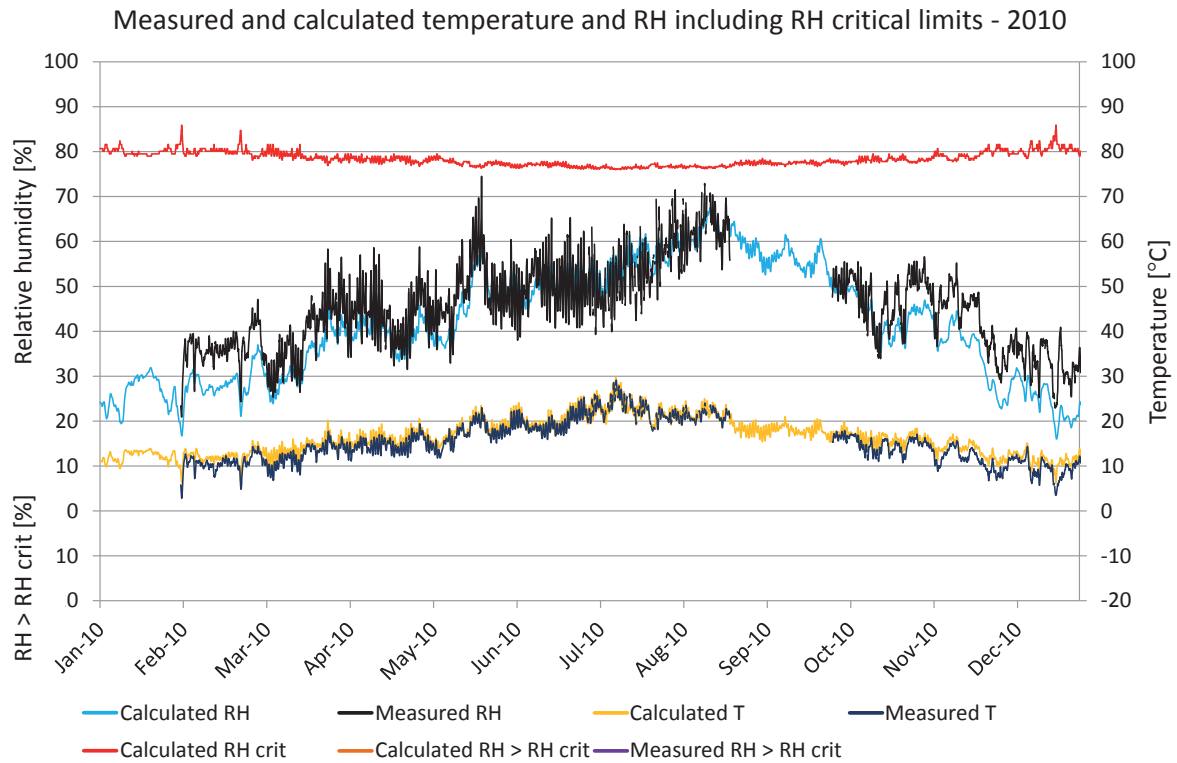

Figure 7.8.9. Comparisons between measured and calculated temperature and relative humidity. Calculated temperature (yellow), measured temperature (dark blue), calculated RH (turquoise), measured RH (black),  $RH_{crit}$  for calculated values (red), calculated  $RH > RH_{crit}$  (light brown), measured  $RH > RH_{crit}$  (purple).

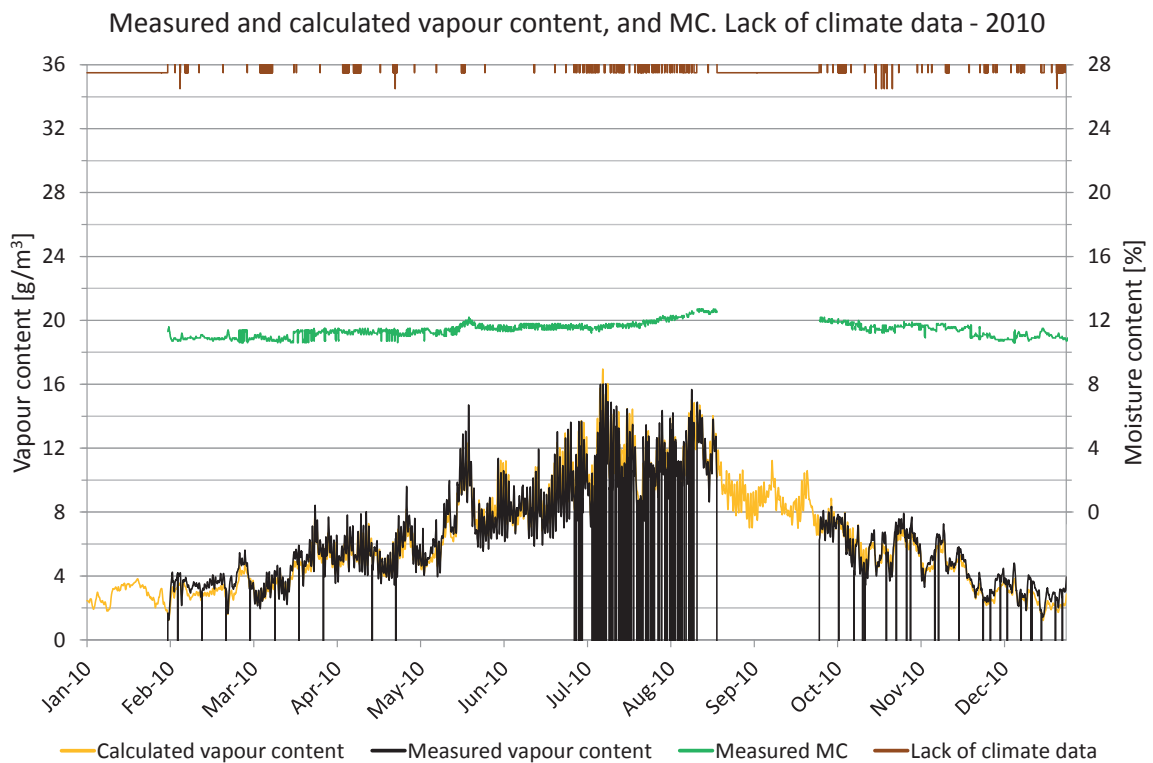

Figure 7.8.10. Measured moisture content, periods lacking climate data and comparisons of vapour content. Vapour content for calculated values (yellow) and measured values (black). Moisture content (green), periods with lack of climate data (brown).

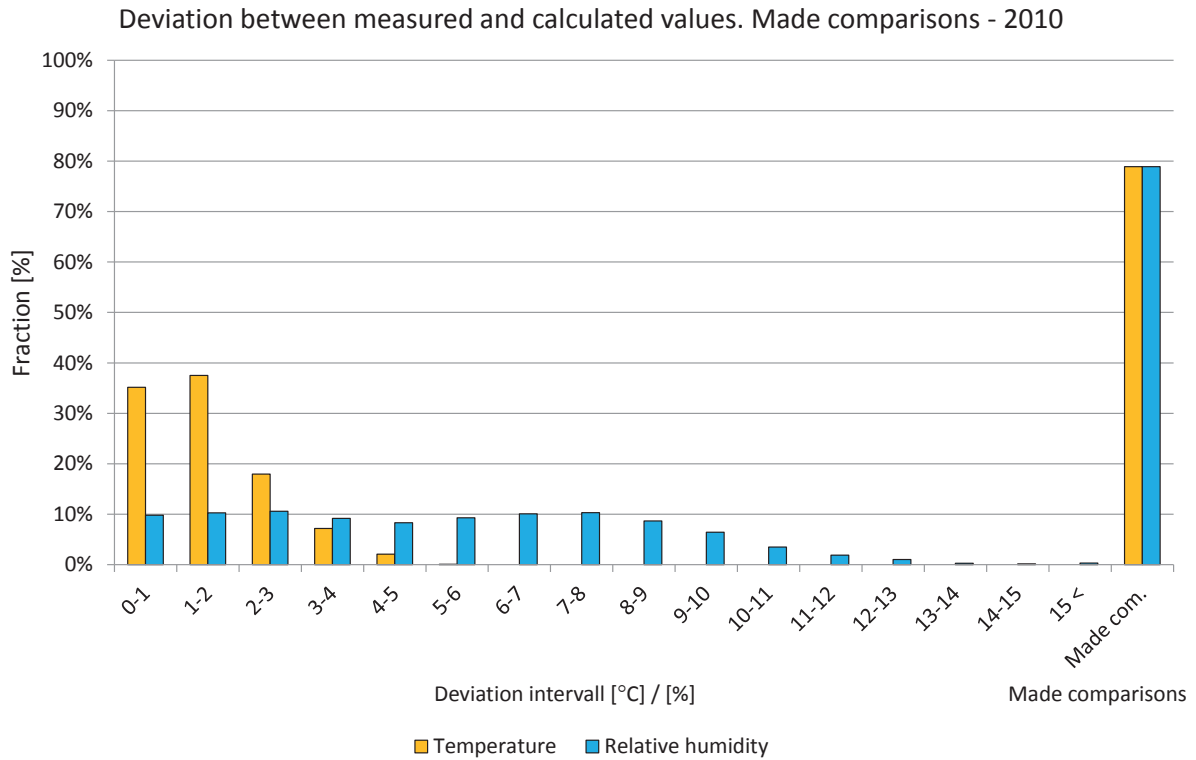

Figure 7.8.11. Deviations in comparisons shown in intervals from 0 to 15 °C or %. The two right-hand bars show the percentage of comparisons during the year. Temperature (yellow) and relative humidity (light blue).

**Year 2011**

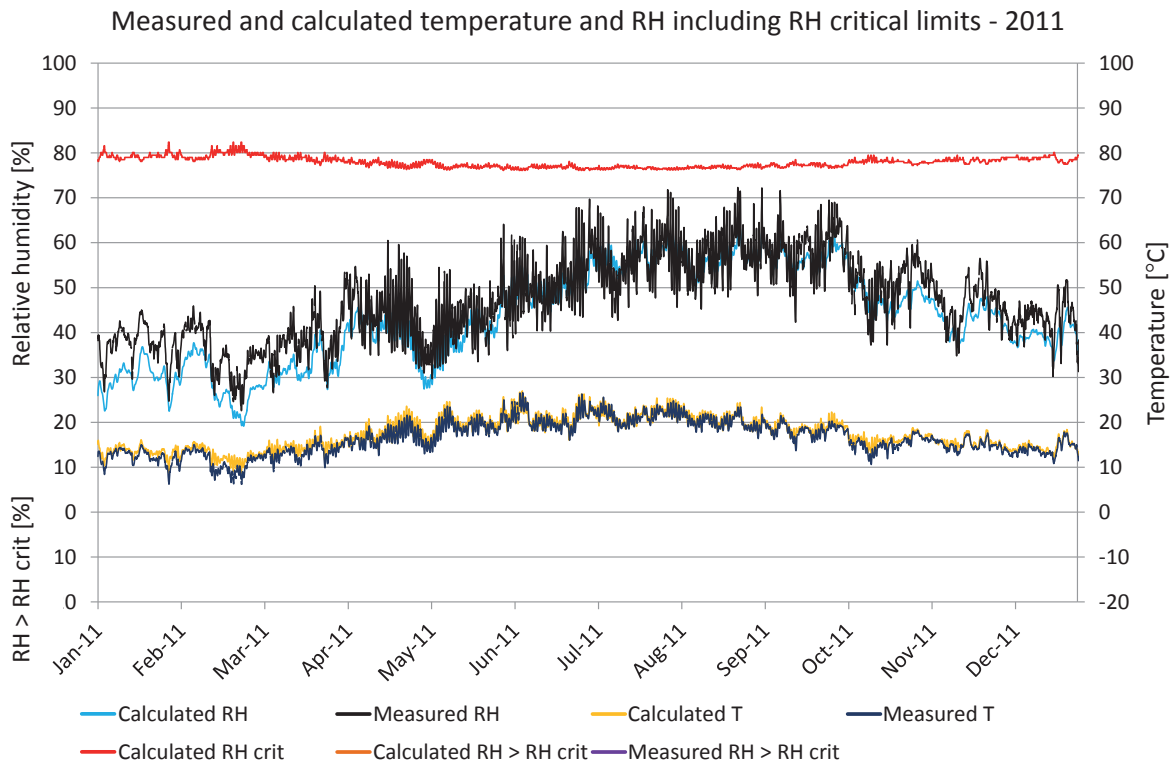

Figure 7.8.12. Comparisons between measured and calculated temperature and relative humidity. Calculated temperature (yellow), measured temperature (dark blue), calculated RH (turquoise), measured RH (black), RH<sub>crit</sub> for calculated values (red), calculated RH > RH<sub>crit</sub> (light brown), measured RH > RH<sub>crit</sub> (purple).



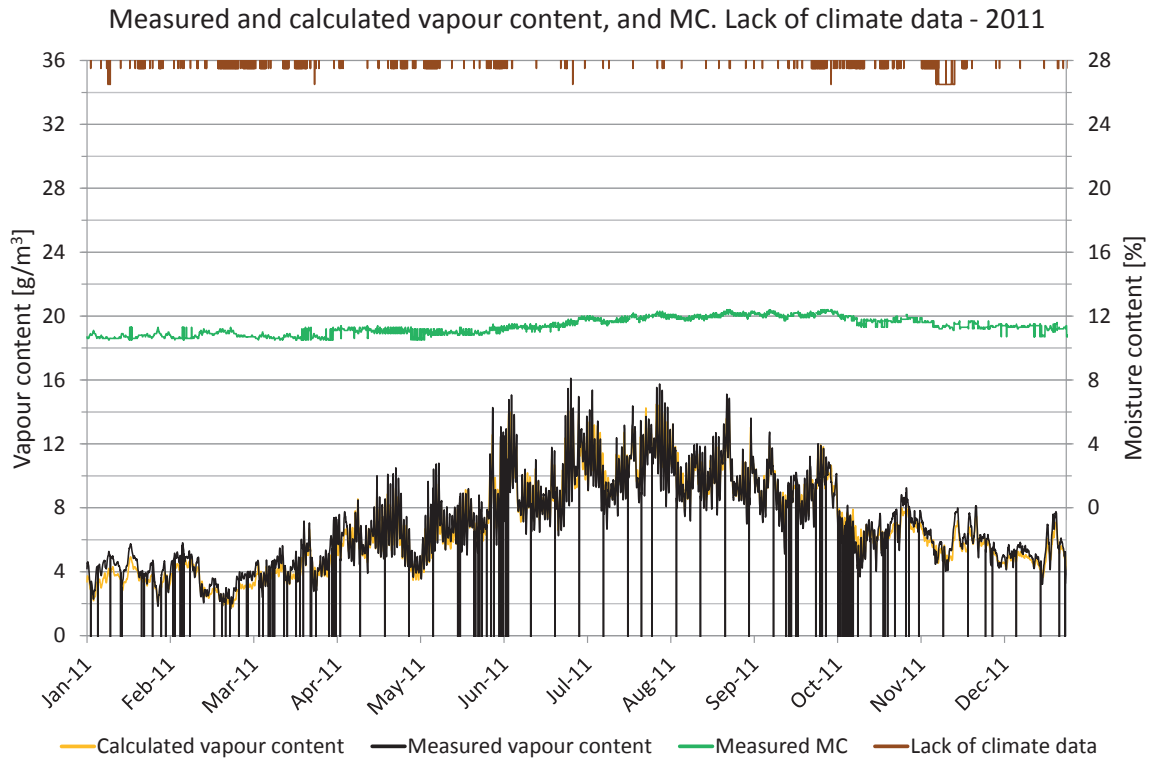

Figure 7.8.13. Measured moisture content, periods lacking climate data and comparisons of vapour content. Vapour content for calculated values (yellow) and measured values (black). Moisture content (green), periods with lack of climate data (brown).

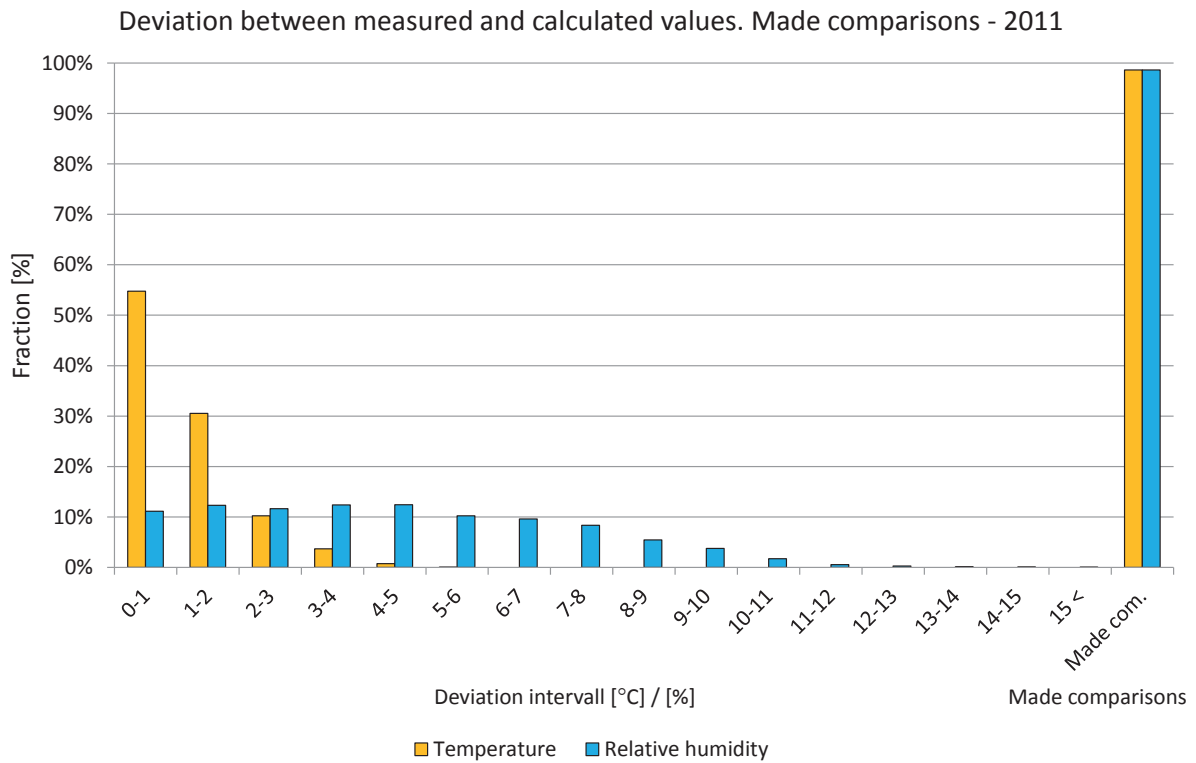

Figure 7.8.14. Deviations in comparisons shown in intervals from 0 to 15 °C or %. The two right-hand bars show the percentage of comparisons during the year. Temperature (yellow) and relative humidity (light blue).



## 7.9 Position 9

The locations of the measured and calculated position are shown in the drawings and figures below. The studied position is located in a wall facing northwest on the first floor.

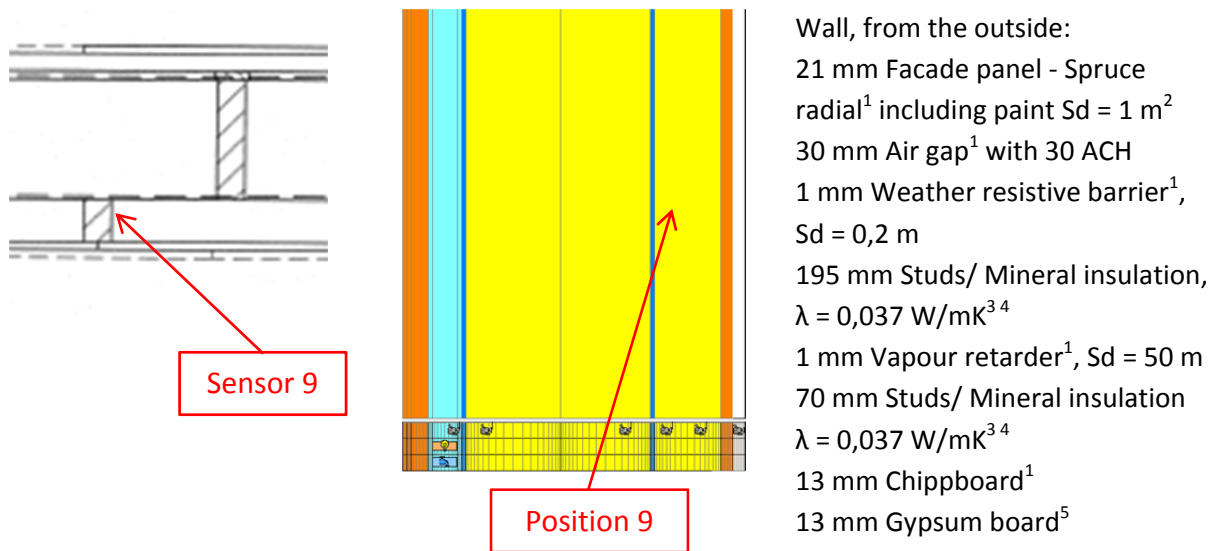

Figure 7.9.1. Vertical cross sectional drawing and WUFI calculation model showing the studied position. 1. IBP, 2012, 2. Nevander, L-E., 1994, 3. IEA Annex 24, 1996, 4. Paroc, 2002, 5. Krus, M., 1996.

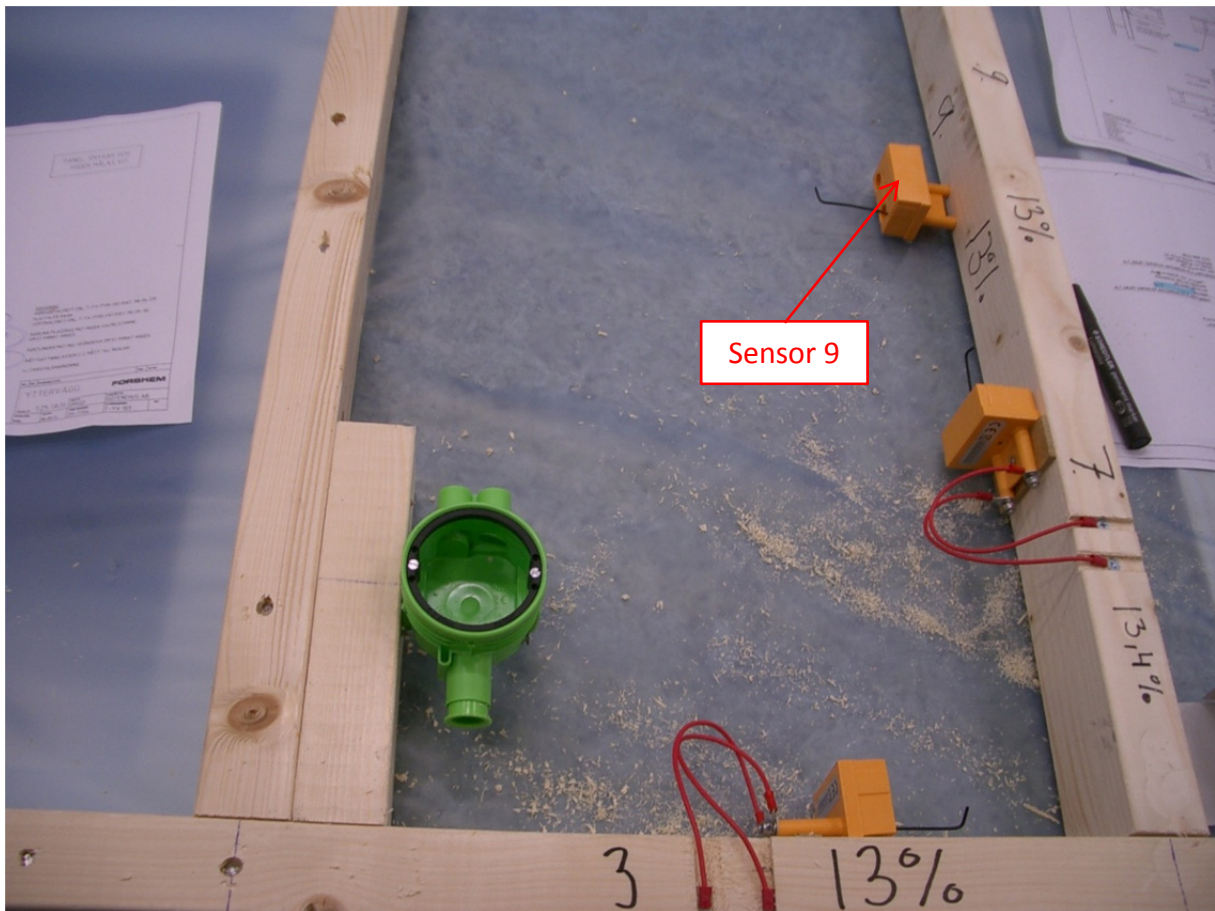

Figure 7.9.2. Location of the studied position. Photo: Götenehus AB.

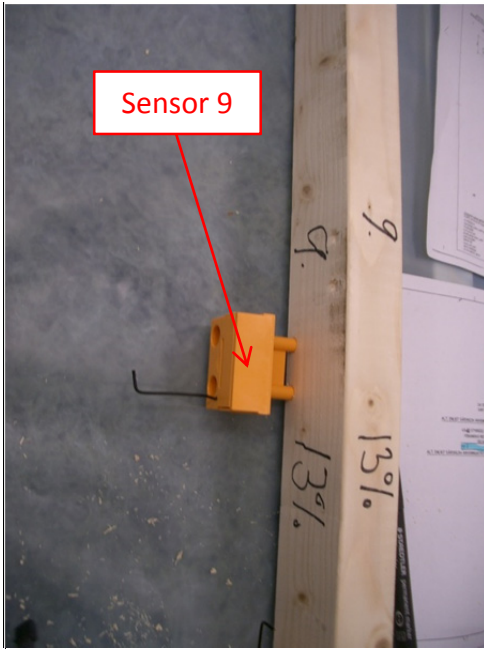

Figure 7.9.3. Location of the studied position.

A perfect match between the measured and calculated values cannot be expected due to e.g. the influence of two- and three-dimensional effects and the accuracy of the sensors.

### Year 2008

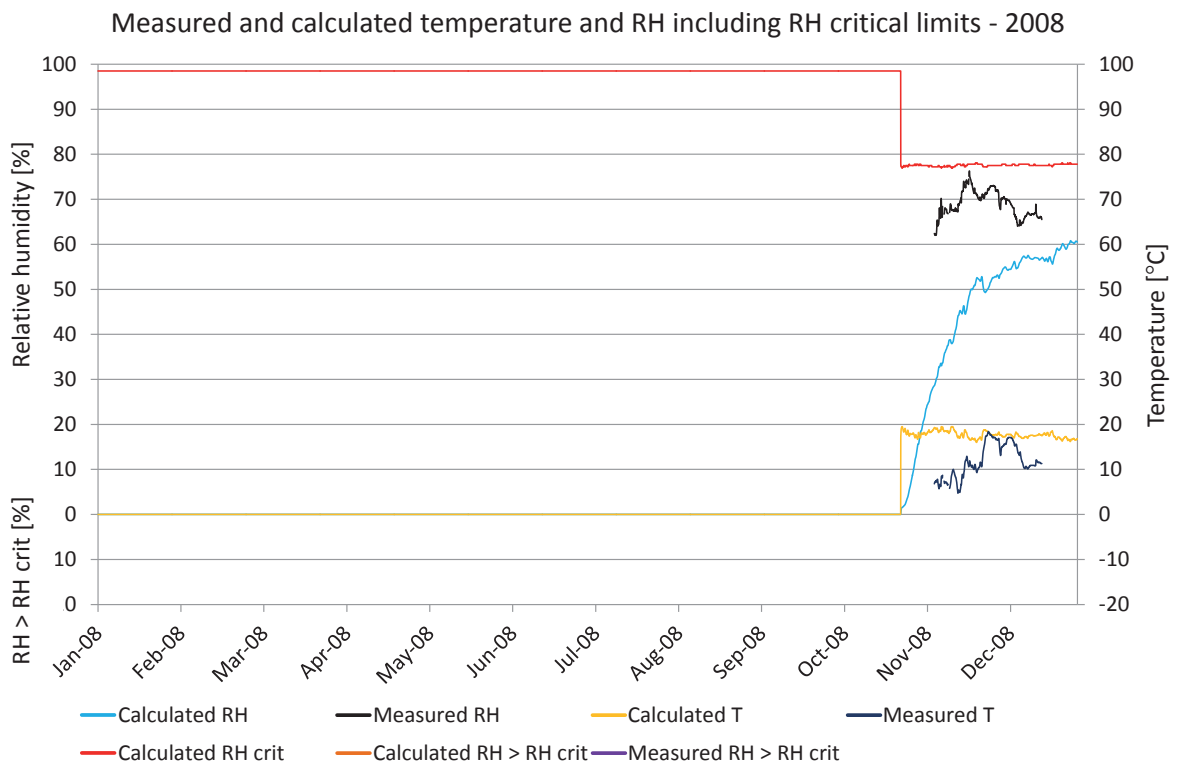

Figure 7.9.4. Comparisons between measured and calculated temperature and relative humidity. Calculated temperature (yellow), measured temperature (dark blue), calculated RH (turquoise), measured RH (black),  $RH_{crit}$  for calculated values (red), calculated  $RH > RH_{crit}$  (light brown), measured  $RH > RH_{crit}$  (purple).

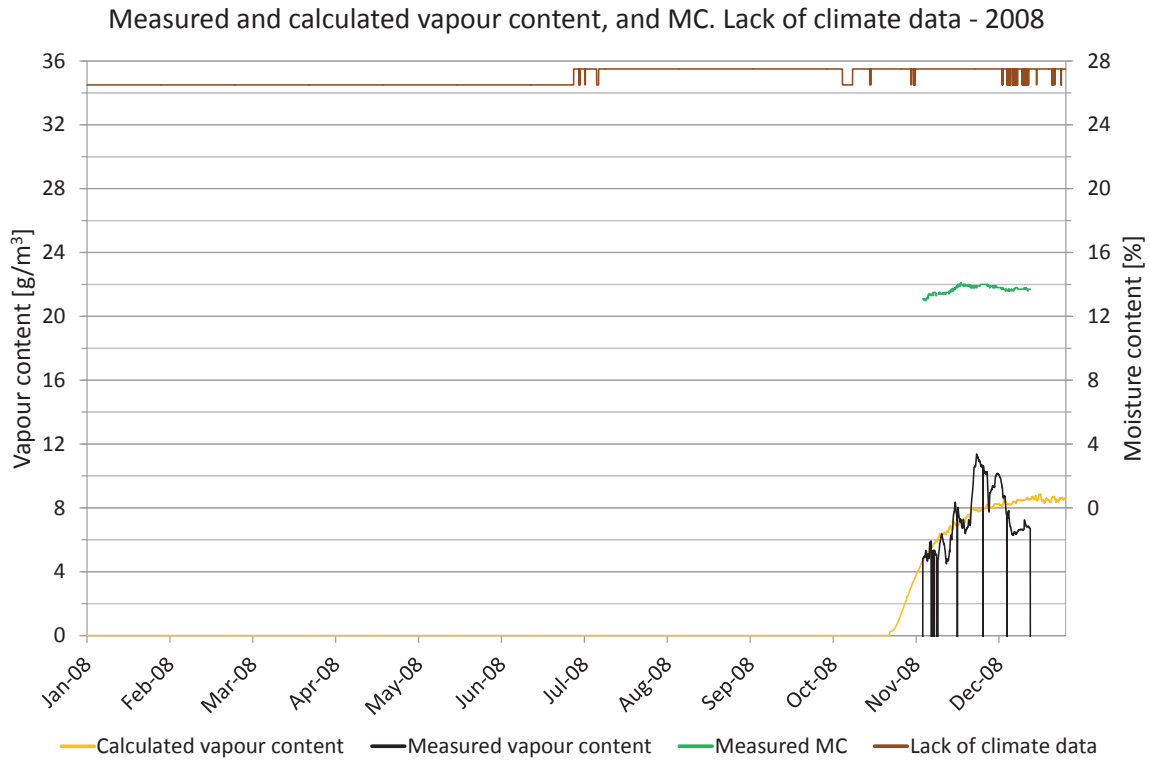

Figure 7.9.5. Measured moisture content, periods lacking climate data and comparisons of vapour content. Vapour content for calculated values (yellow) and measured values (black). Moisture content (green), periods with lack of climate data (brown).

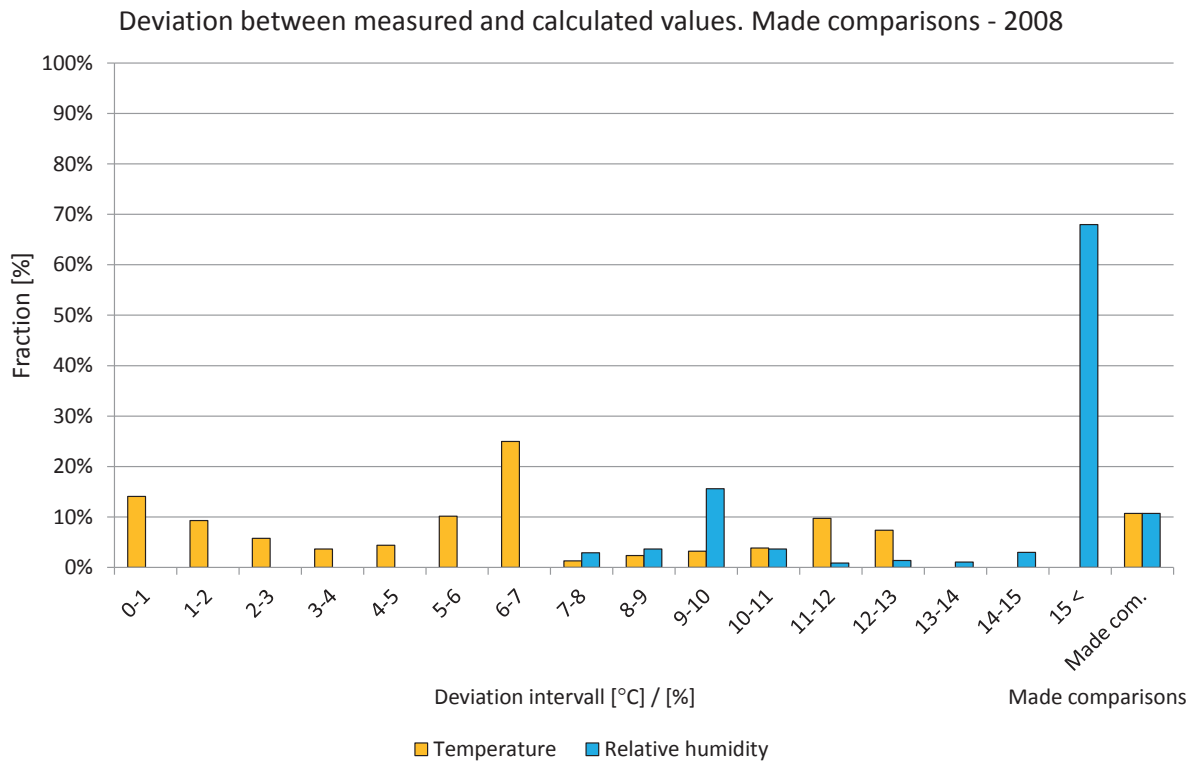

Figure 7.9.6. Deviations in comparisons shown in intervals from 0 to 15 °C or %. The two right-hand bars show the percentage of comparisons during the year. Temperature (yellow) and relative humidity (light blue).

**Year 2009**

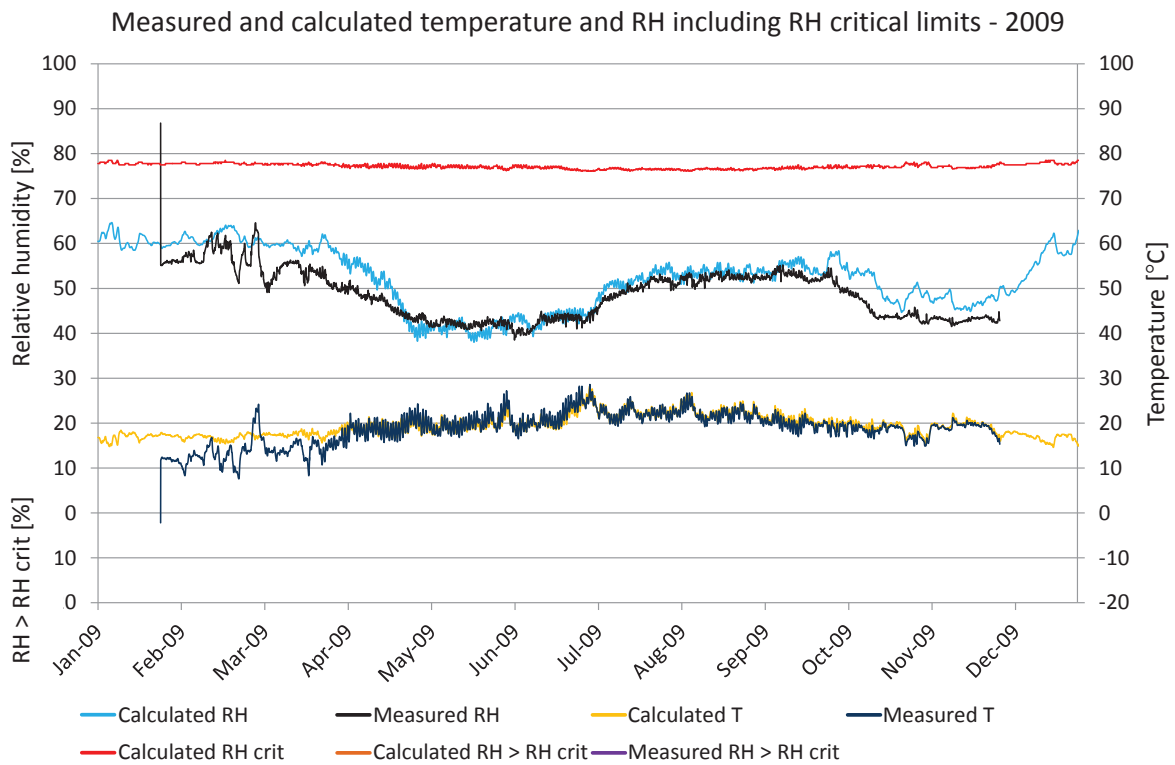

Figure 7.9.7. Comparisons between measured and calculated temperature and relative humidity. Calculated temperature (yellow), measured temperature (dark blue), calculated RH (turquoise), measured RH (black),  $RH_{crit}$  for calculated values (red), calculated  $RH > RH_{crit}$  (light brown), measured  $RH > RH_{crit}$  (purple).

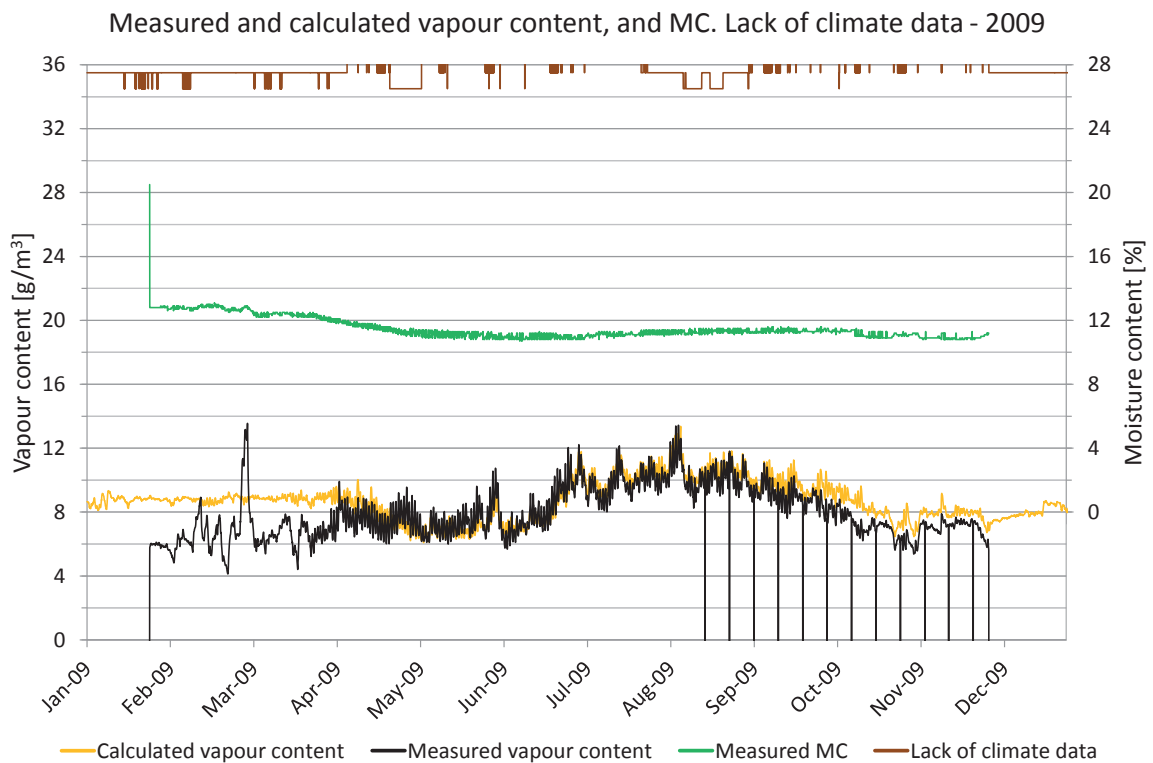

Figure 7.9.8. Measured moisture content, periods lacking climate data and comparisons of vapour content. Vapour content for calculated values (yellow) and measured values (black). Moisture content (green), periods with lack of climate data (brown).

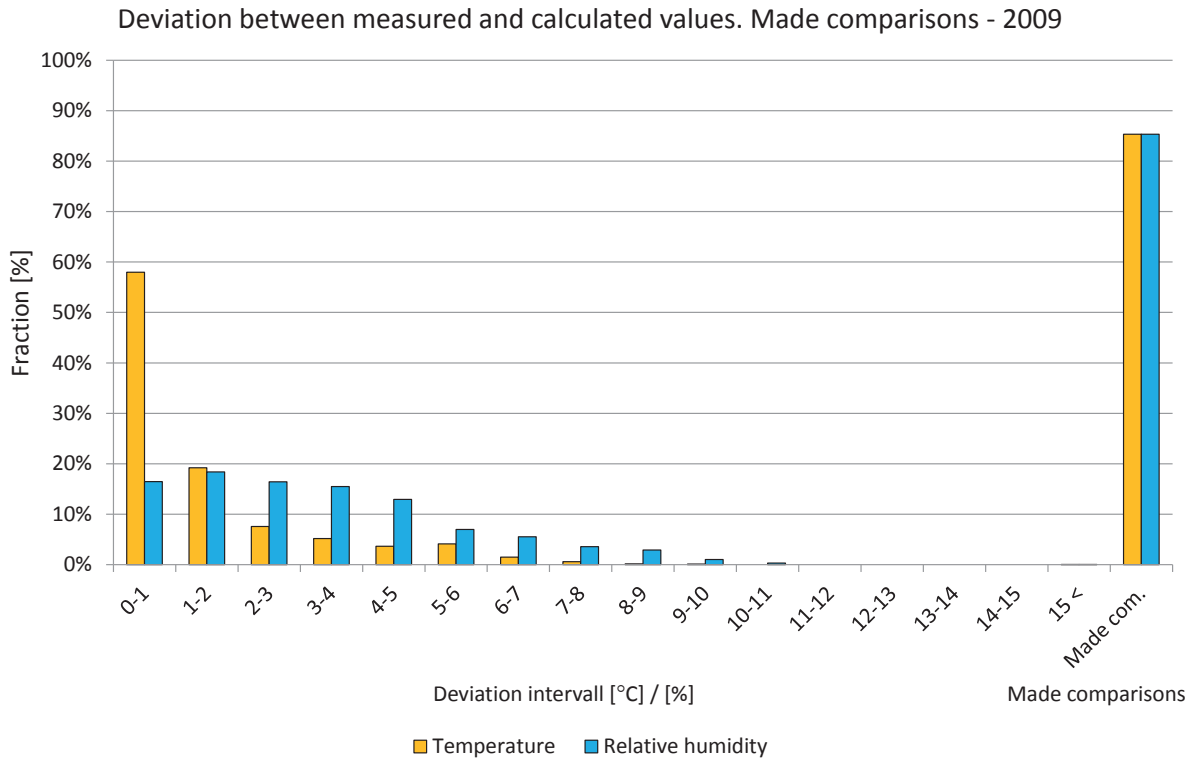

Figure 7.9.9. Deviations in comparisons shown in intervals from 0 to 15 °C or %. The two right-hand bars show the percentage of comparisons during the year. Temperature (yellow) and relative humidity (light blue).

**Year 2010**

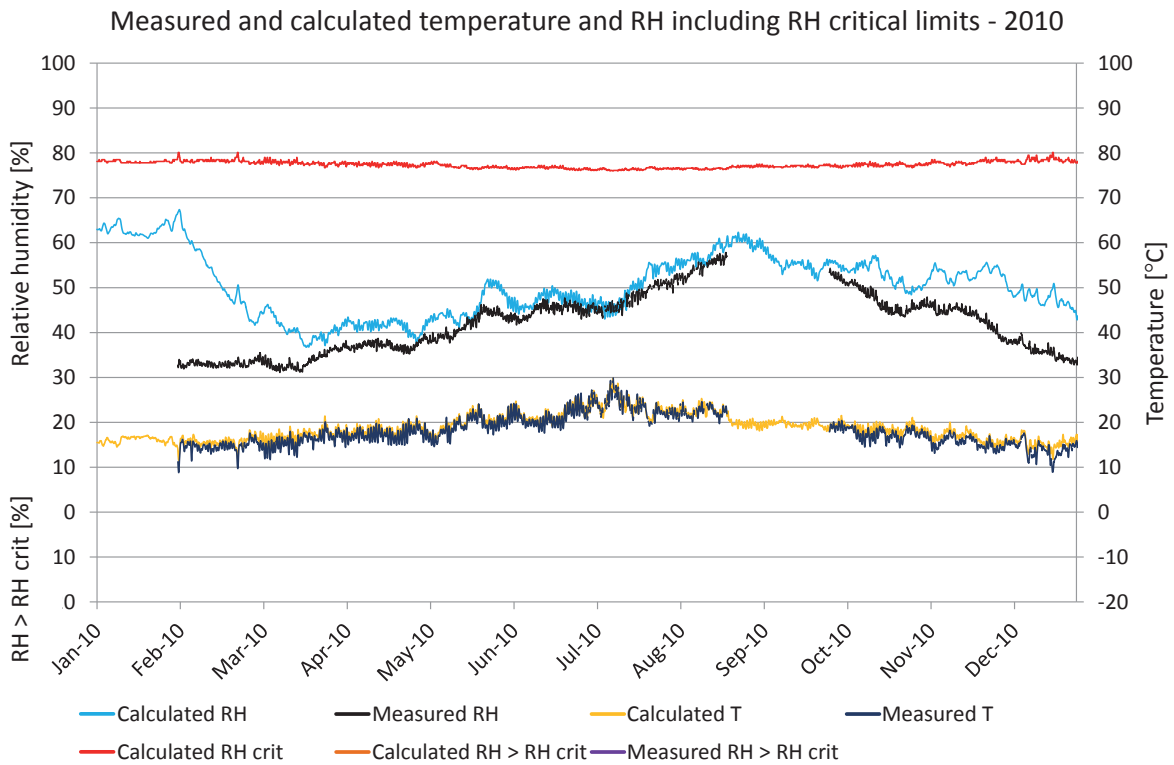

Figure 7.9.10. Comparisons between measured and calculated temperature and relative humidity. Calculated temperature (yellow), measured temperature (dark blue), calculated RH (turquoise), measured RH (black),  $RH_{crit}$  for calculated values (red), calculated  $RH > RH_{crit}$  (light brown), measured  $RH > RH_{crit}$  (purple).

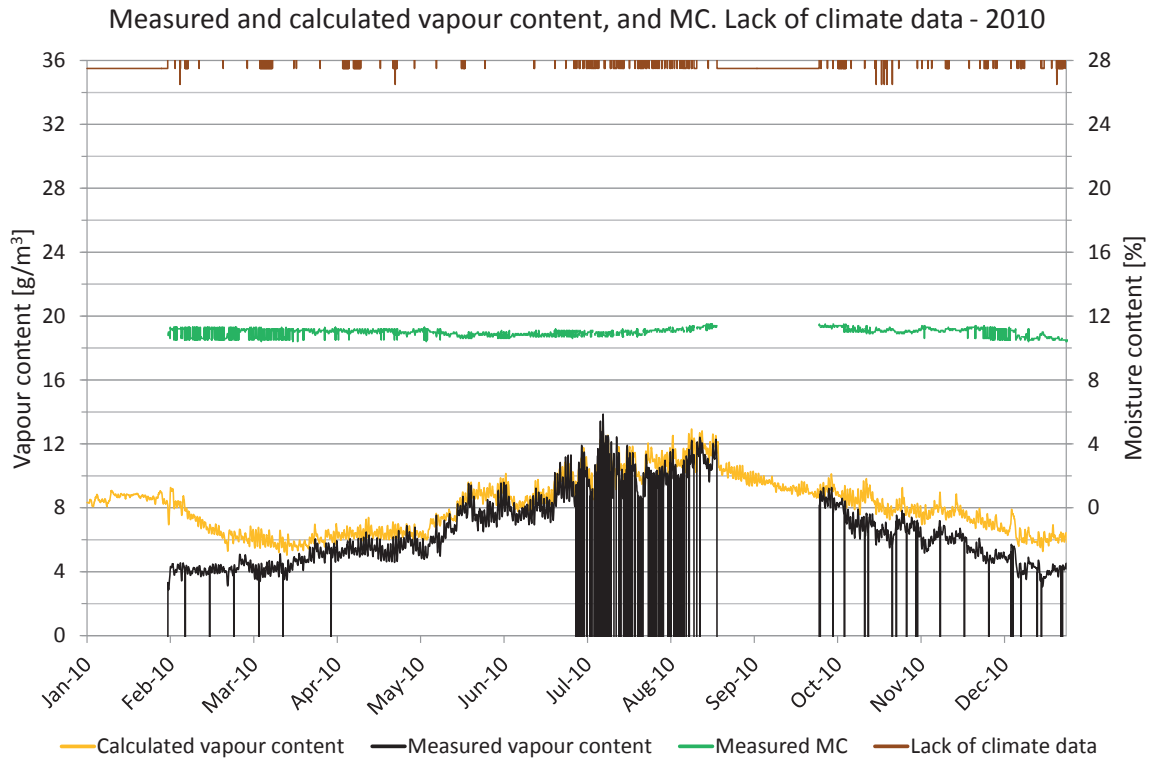

Figure 7.9.11. Measured moisture content, periods lacking climate data and comparisons of vapour content. Vapour content for calculated values (yellow) and measured values (black). Moisture content (green), periods with lack of climate data (brown).

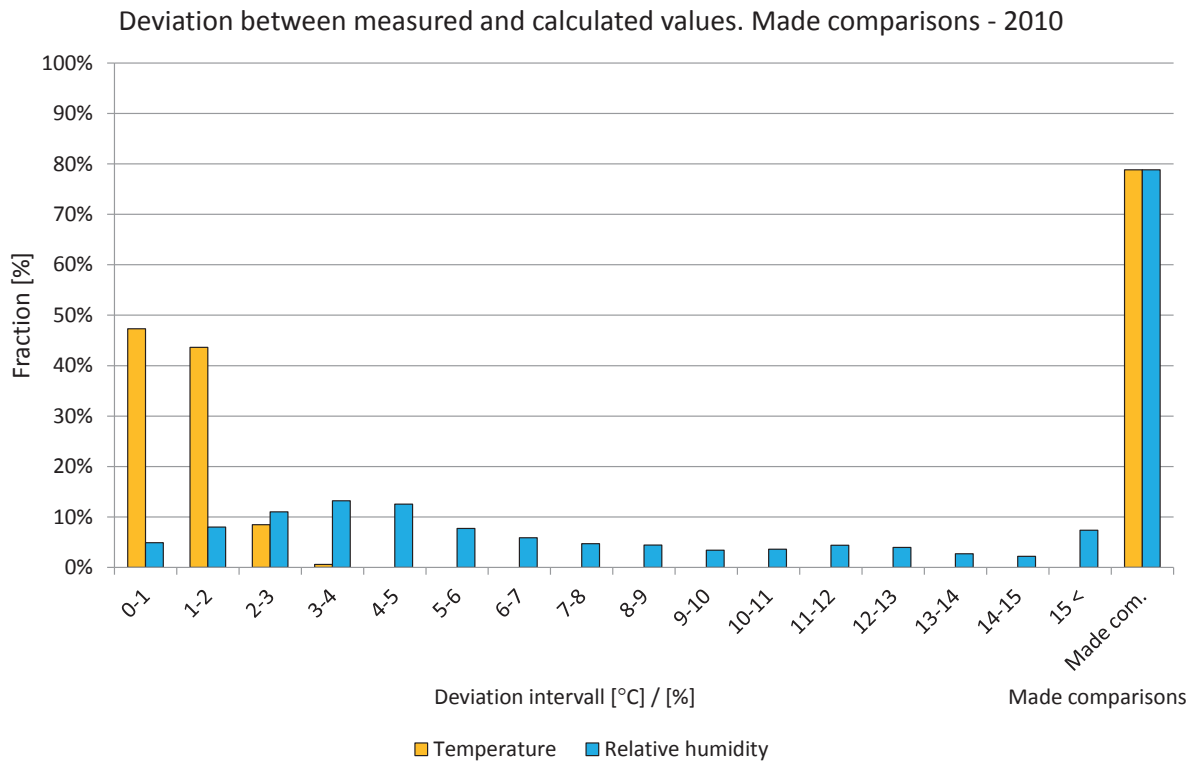

Figure 7.9.12. Deviations in comparisons shown in intervals from 0 to 15 °C or %. The two right-hand bars show the percentage of comparisons during the year. Temperature (yellow) and relative humidity (light blue).



**Year 2011**

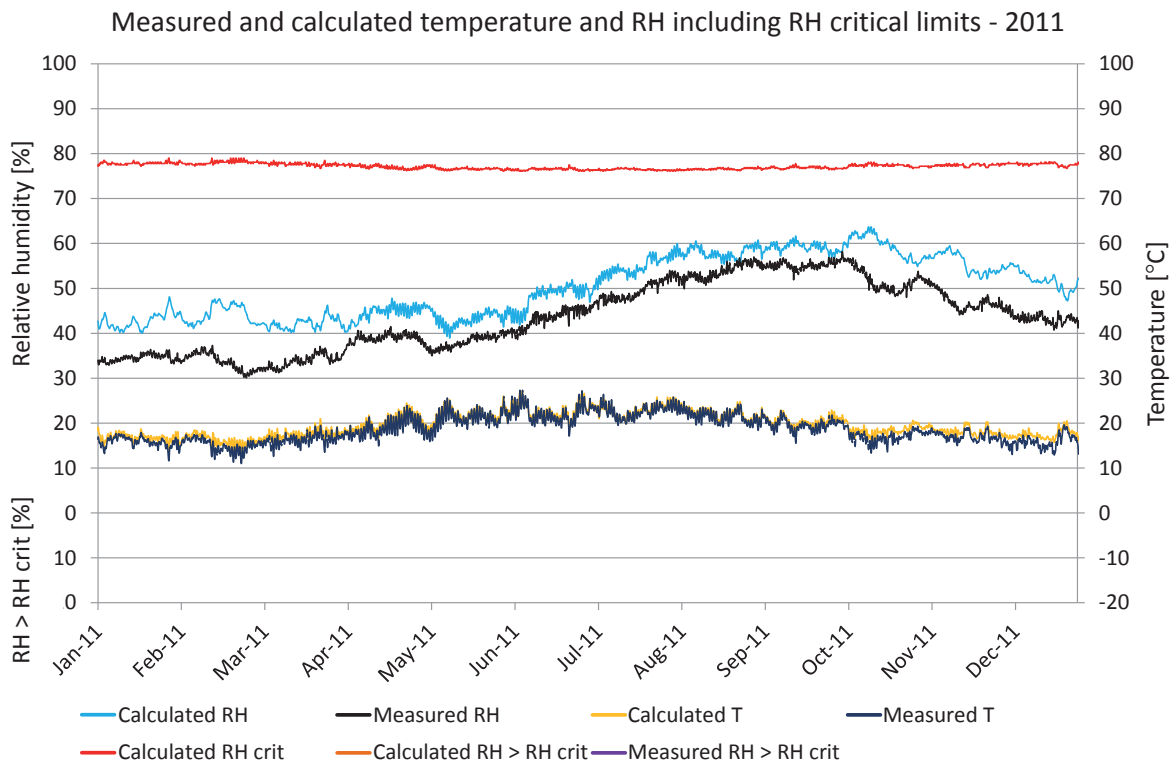

Figure 7.9.13. Comparisons between measured and calculated temperature and relative humidity. Calculated temperature (yellow), measured temperature (dark blue), calculated RH (turquoise), measured RH (black),  $RH_{crit}$  for calculated values (red), calculated  $RH > RH_{crit}$  (light brown), measured  $RH > RH_{crit}$  (purple).

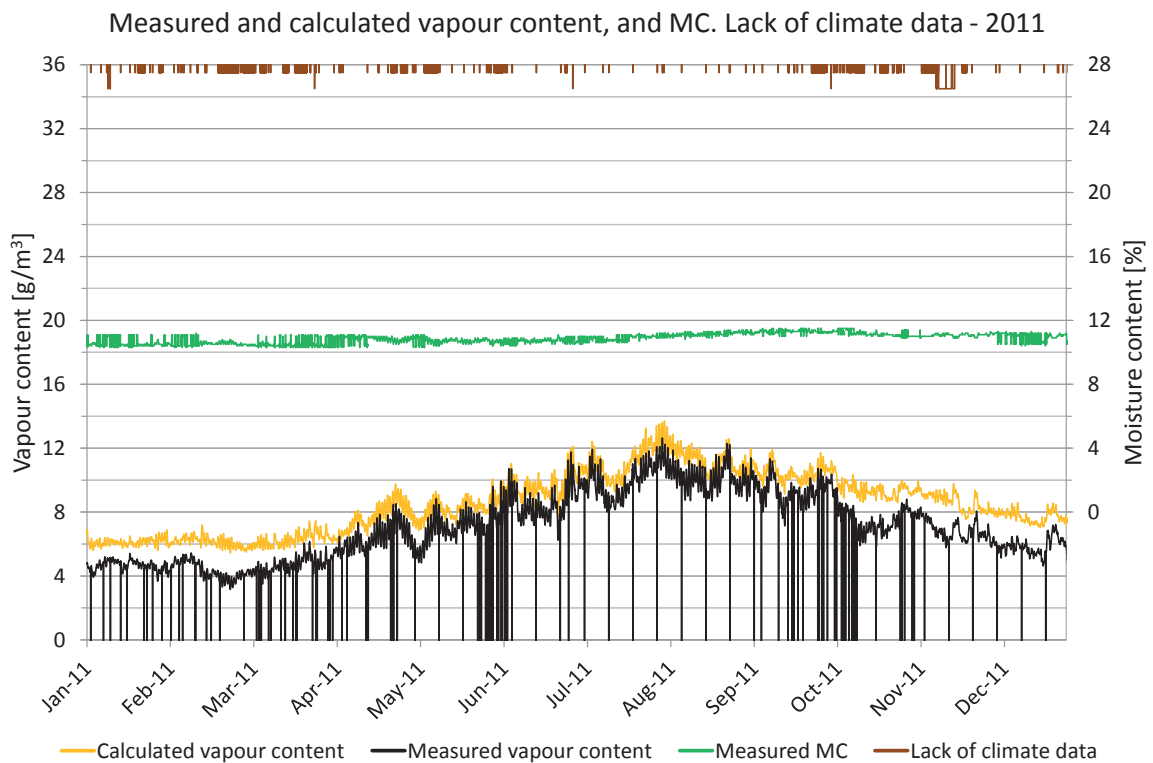

Figure 7.9.14. Measured moisture content, periods lacking climate data and comparisons of vapour content. Vapour content for calculated values (yellow) and measured values (black). Moisture content (green), periods with lack of climate data (brown).

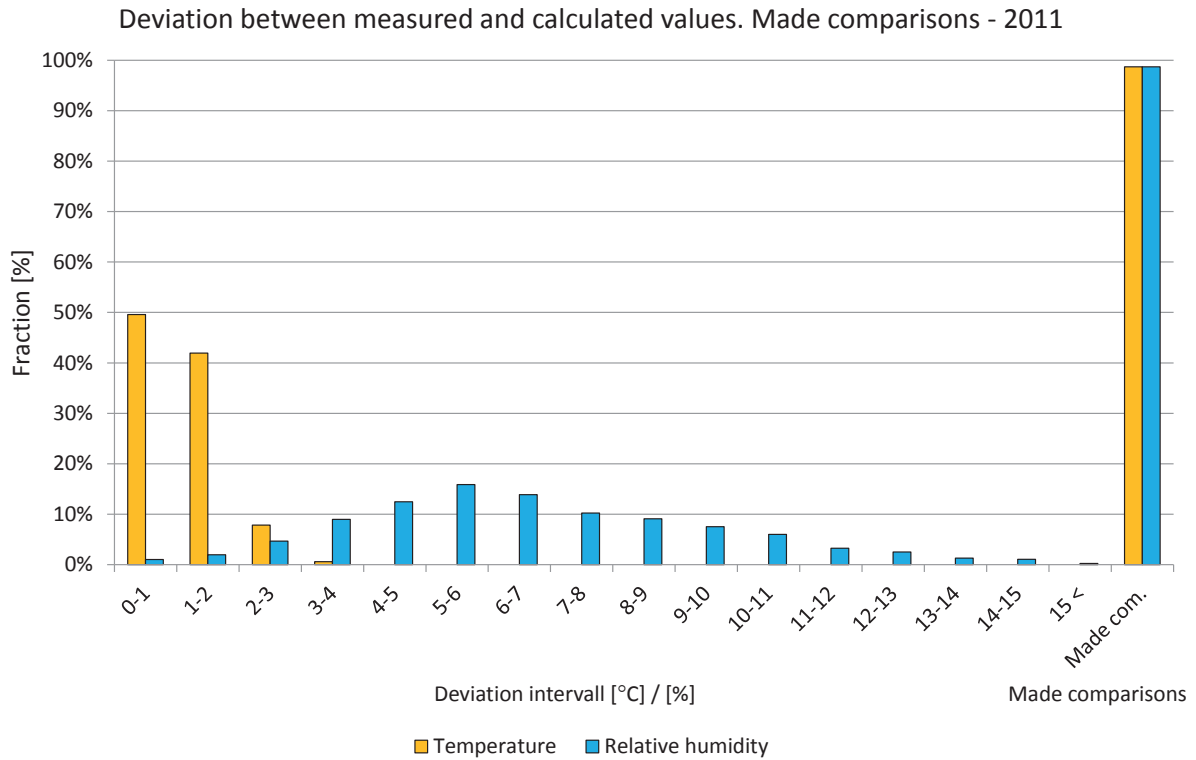

Figure 7.9.15. Deviations in comparisons shown in intervals from 0 to 15 °C or %. The two right-hand bars show the percentage of comparisons during the year. Temperature (yellow) and relative humidity (light blue).

## 7.10 Position 10

The locations of the measured and calculated position are shown in the drawings and figures below. The studied position is located in a wall facing northeast.

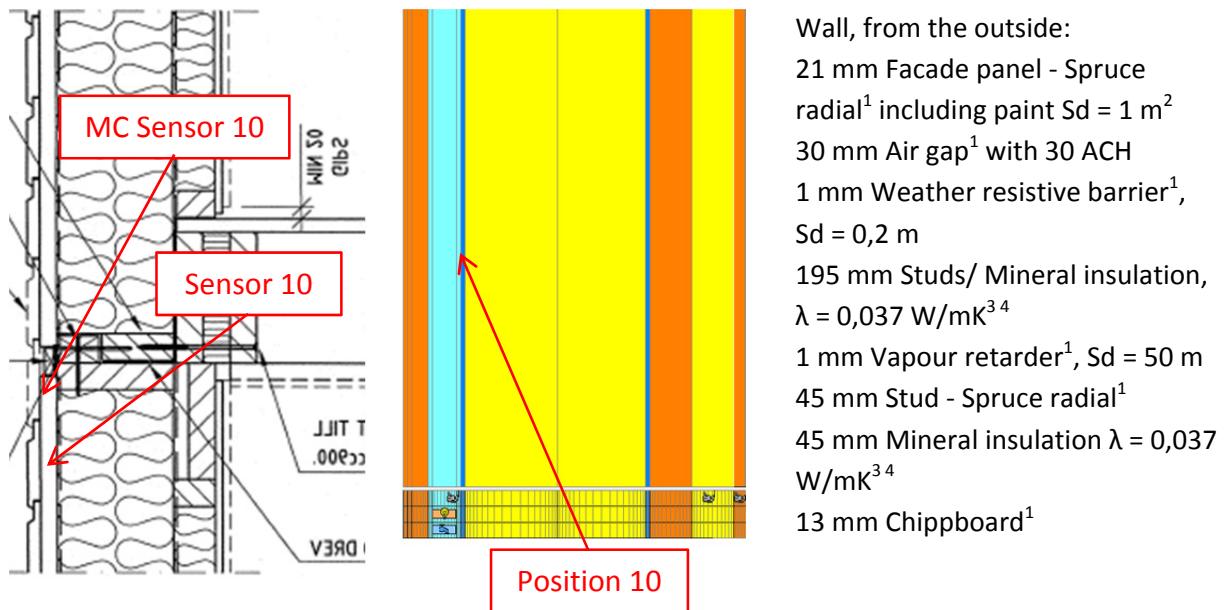

Figure 7.10.1. Vertical cross sectional drawing and WUFI calculation model showing the studied position. 1. IBP, 2012, 2. Nevander, L-E., 1994, 3. IEA Annex 24, 1996, 4. Paroc, 2002, 5. Krus, M., 1996.

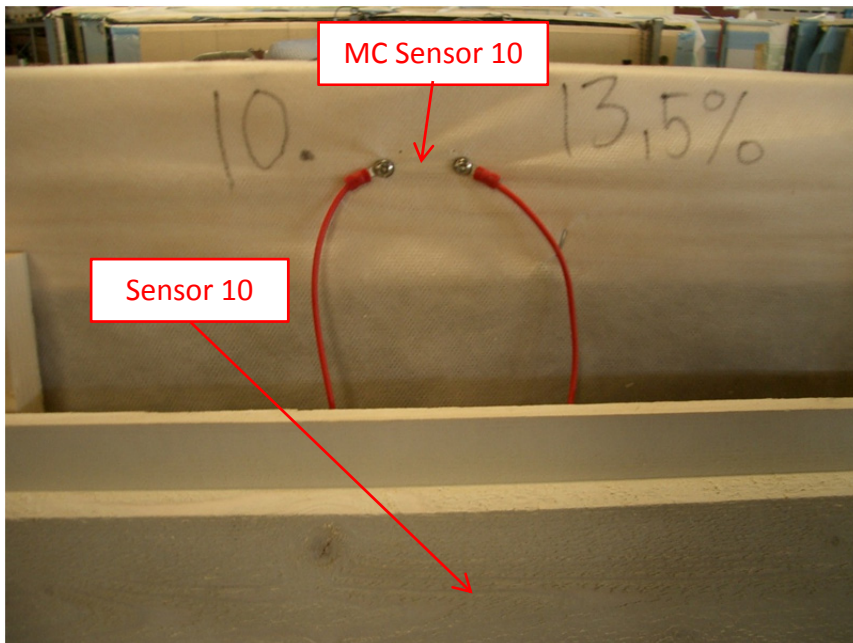

Figure 7.10.2. Location of the studied position behind the façade panel. Photo: Götenehus AB.

A perfect match between the measured and calculated values cannot be expected due to e.g. the influence of two- and three-dimensional effects and the accuracy of the sensors.

**Year 2008**

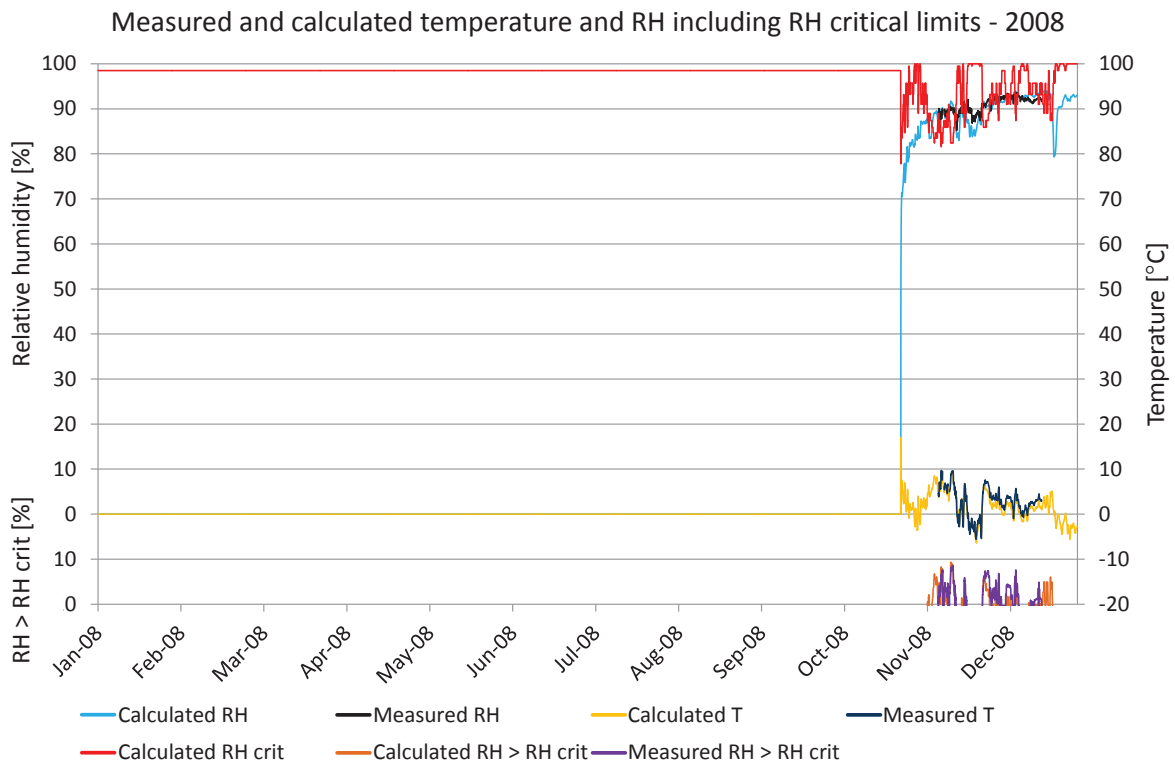

Figure 7.10.3. Comparisons between measured and calculated temperature and relative humidity. Calculated temperature (yellow), measured temperature (dark blue), calculated RH (turquoise), measured RH (black),  $RH_{crit}$  for calculated values (red), calculated  $RH > RH_{crit}$  (light brown), measured  $RH > RH_{crit}$  (purple).

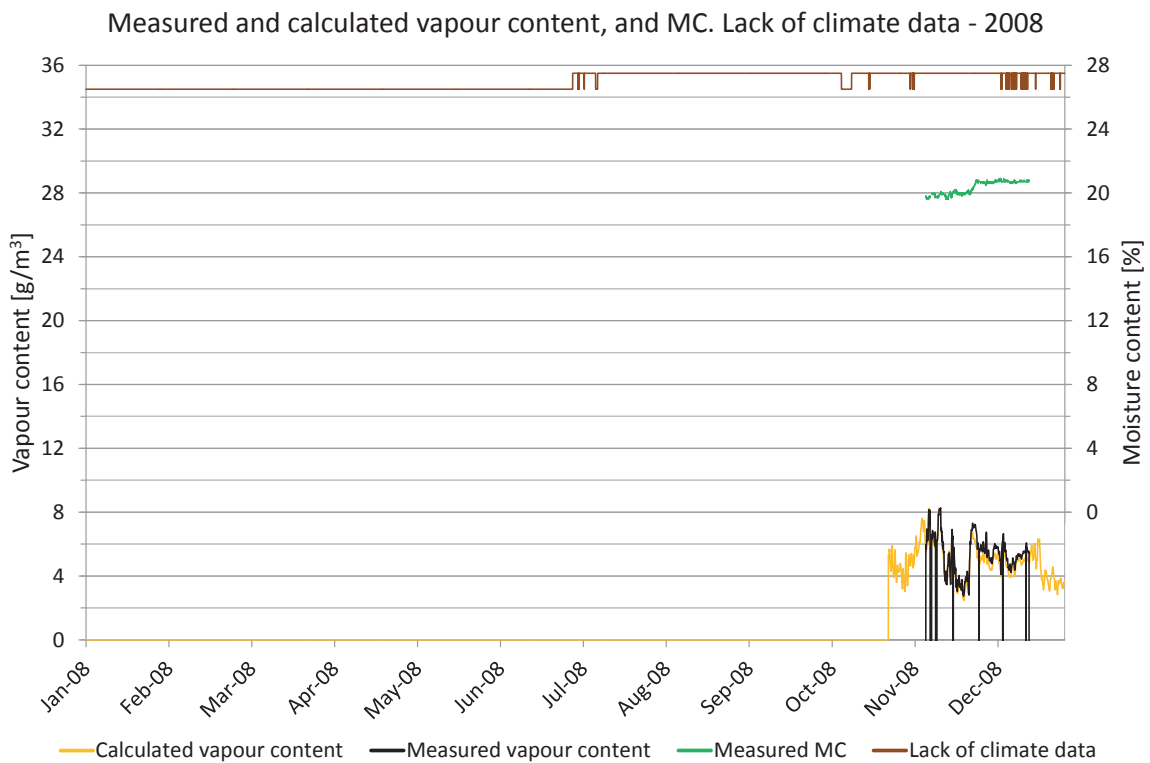

Figure 7.10.4. Measured moisture content, periods lacking climate data and comparisons of vapour content. Vapour content for calculated values (yellow) and measured values (black). Moisture content (green), periods with lack of climate data (brown).

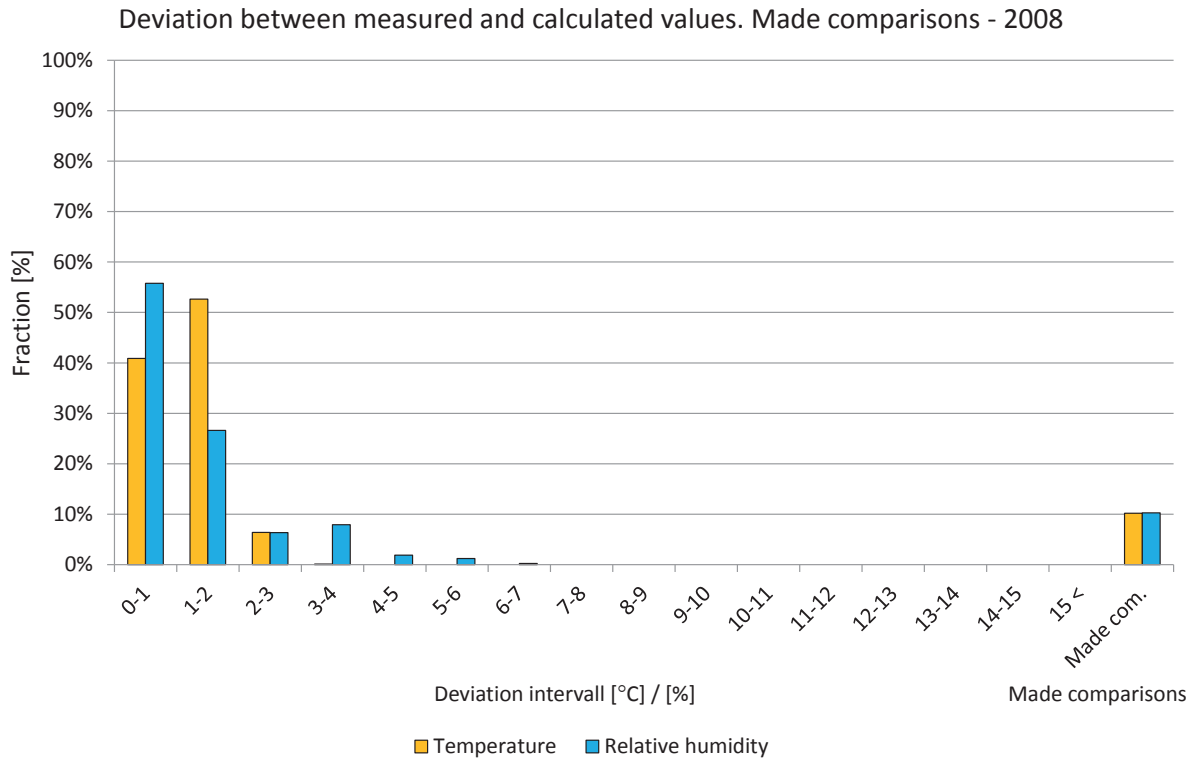

Figure 7.10.5. Deviations in comparisons shown in intervals from 0 to 15 °C or %. The two right-hand bars show the percentage of comparisons during the year. Temperature (yellow) and relative humidity (light blue).

### Year 2009

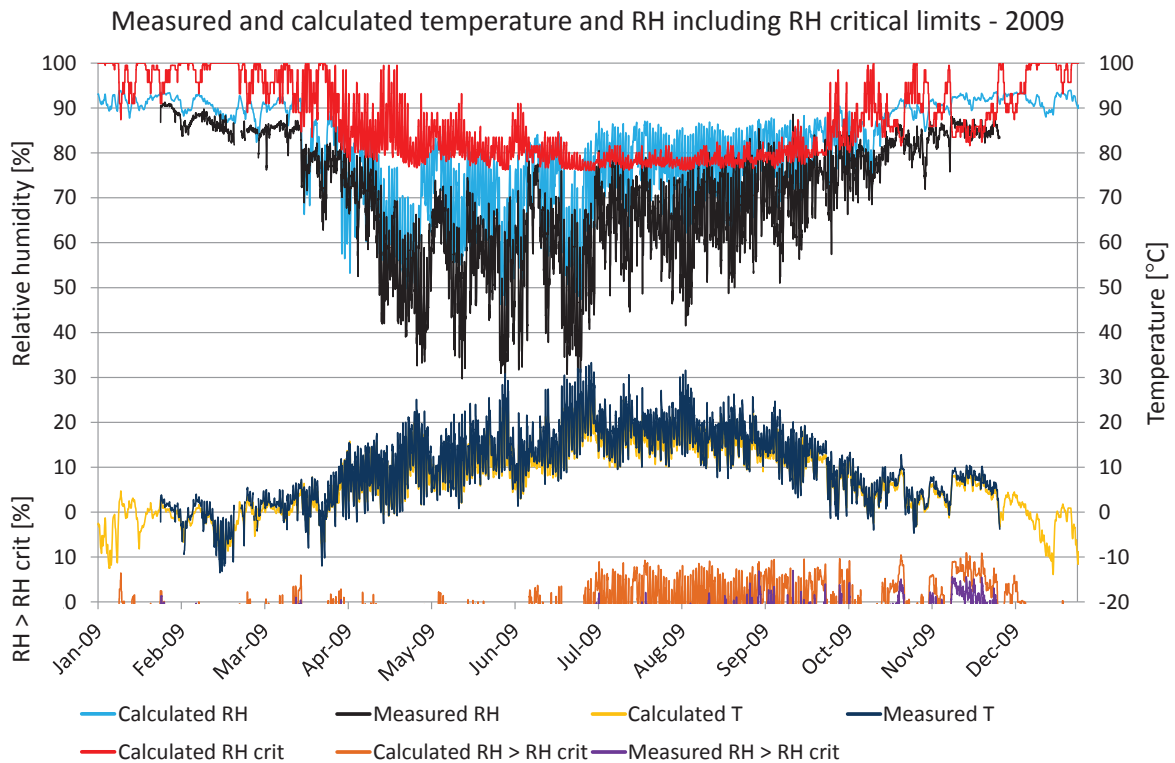

Figure 7.10.6. Comparisons between measured and calculated temperature and relative humidity. Calculated temperature (yellow), measured temperature (dark blue), calculated RH (turquoise), measured RH (black), RH<sub>crit</sub> for calculated values (red), calculated RH > RH<sub>crit</sub> (light brown), measured RH > RH<sub>crit</sub> (purple).

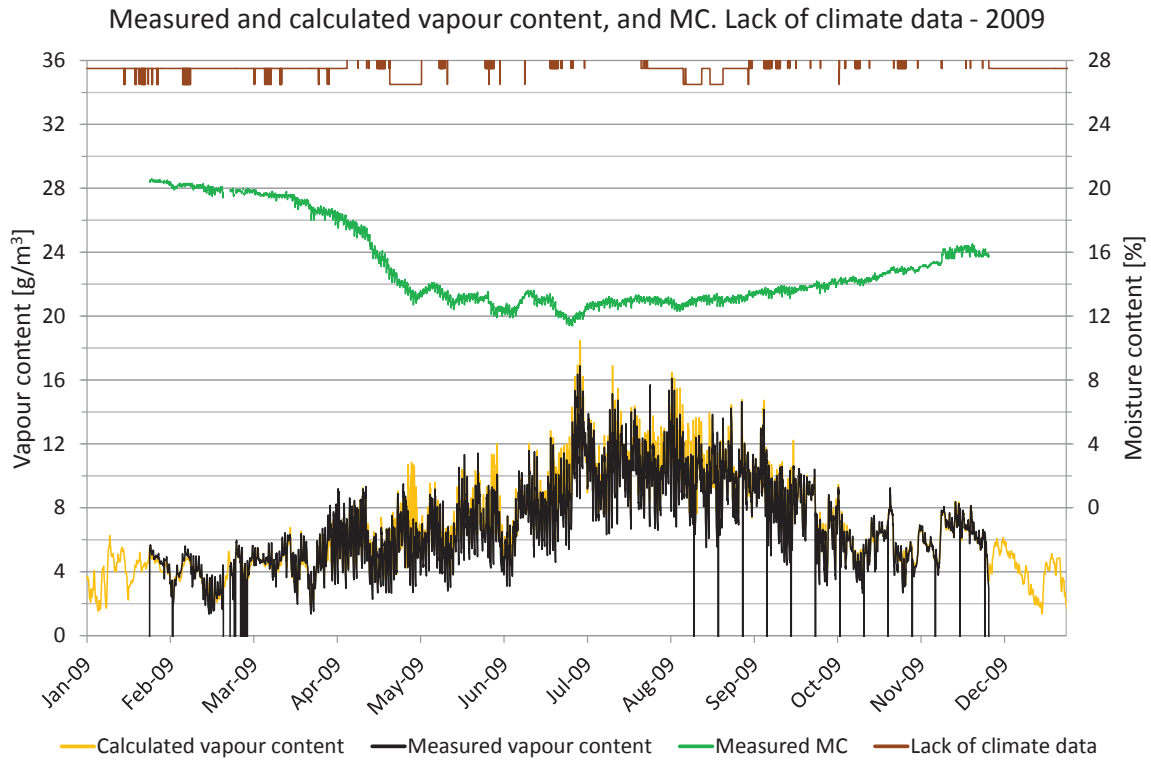

Figure 7.10.7. Measured moisture content, periods lacking climate data and comparisons of vapour content. Vapour content for calculated values (yellow) and measured values (black). Moisture content (green), periods with lack of climate data (brown).

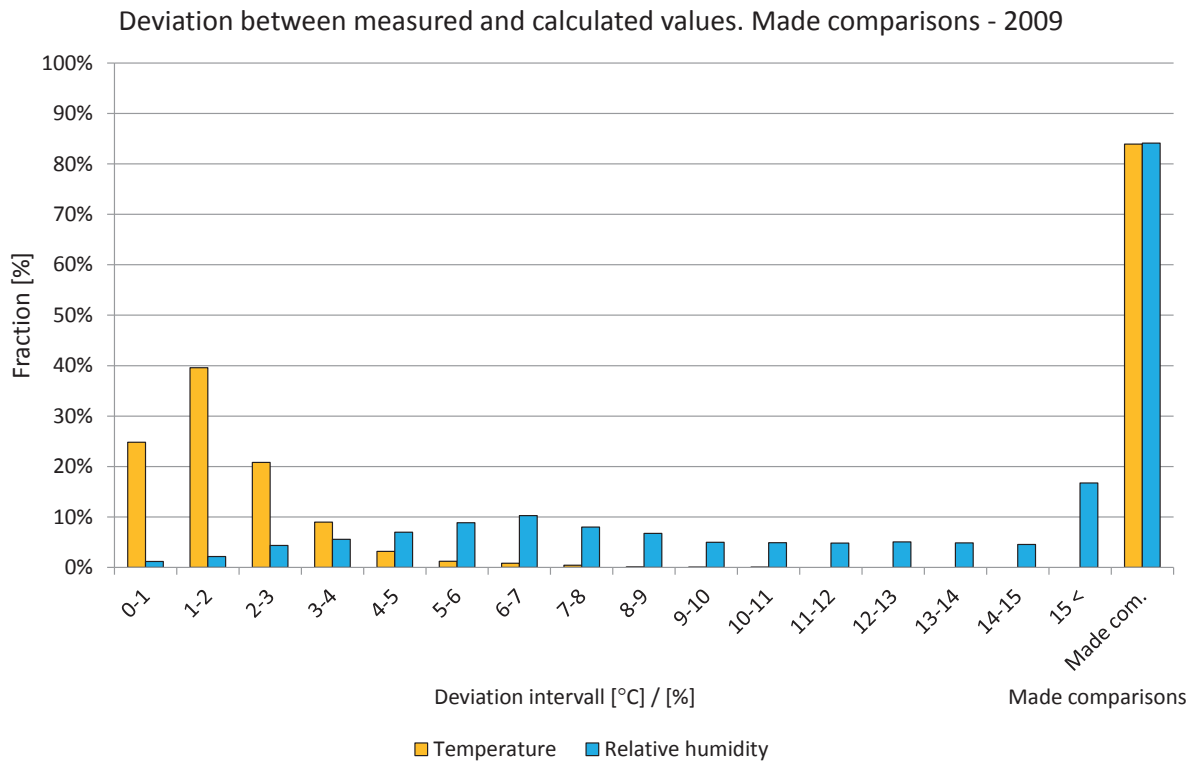

Figure 7.10.8. Deviations in comparisons shown in intervals from 0 to 15 °C or %. The two right-hand bars show the percentage of comparisons during the year. Temperature (yellow) and relative humidity (light blue).

**Year 2010**

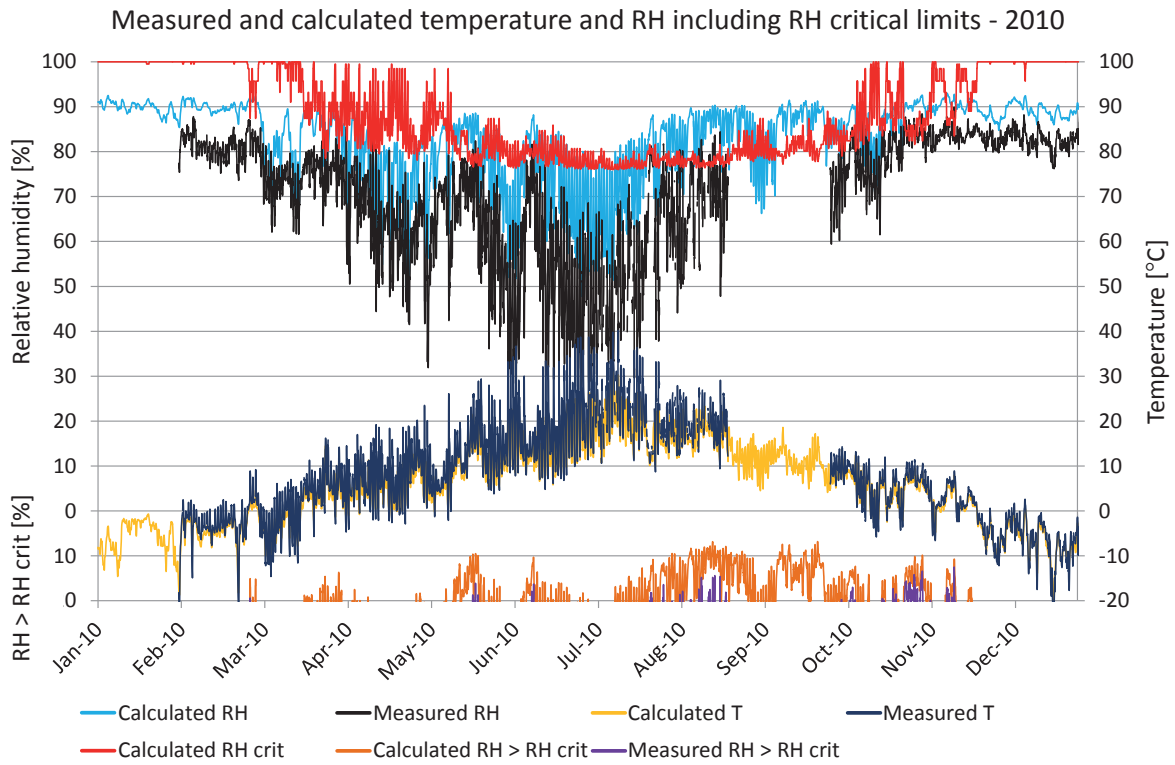

Figure 7.10.9. Comparisons between measured and calculated temperature and relative humidity. Calculated temperature (yellow), measured temperature (dark blue), calculated RH (turquoise), measured RH (black),  $RH_{crit}$  for calculated values (red), calculated  $RH > RH_{crit}$  (light brown), measured  $RH > RH_{crit}$  (purple).

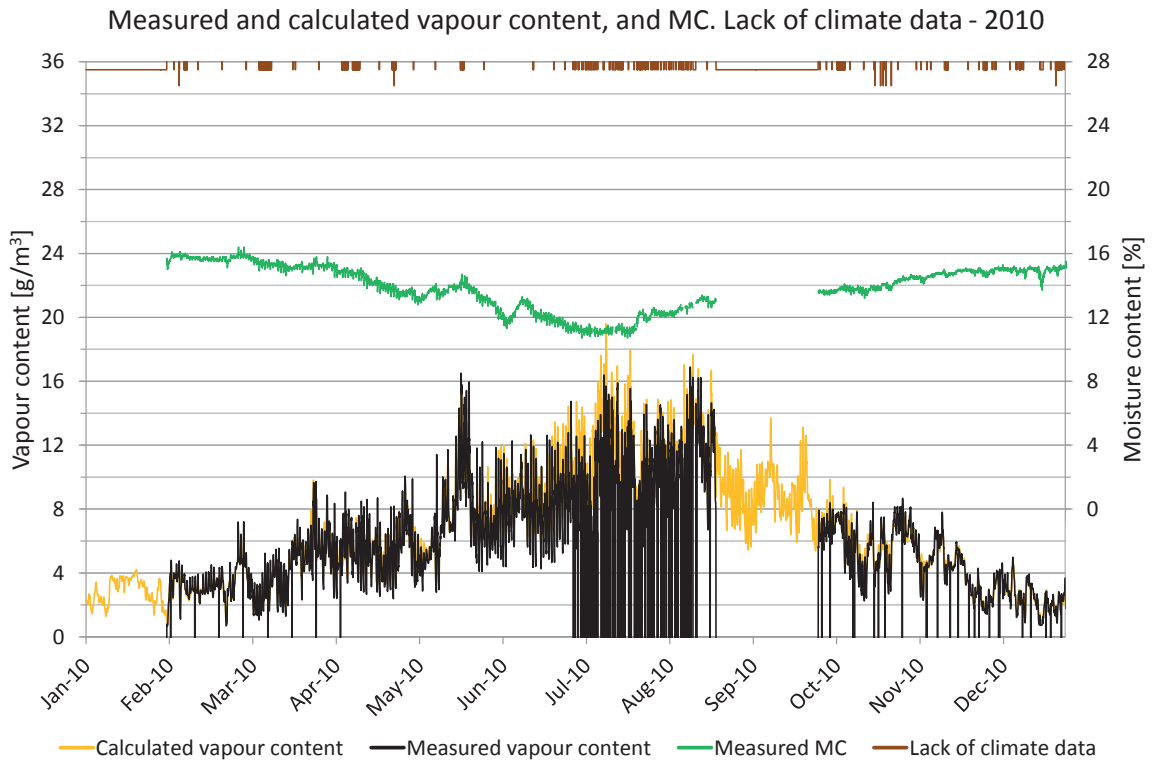

Figure 7.10.10. Measured moisture content, periods lacking climate data and comparisons of vapour content. Vapour content for calculated values (yellow) and measured values (black). Moisture content (green), periods with lack of climate data (brown).

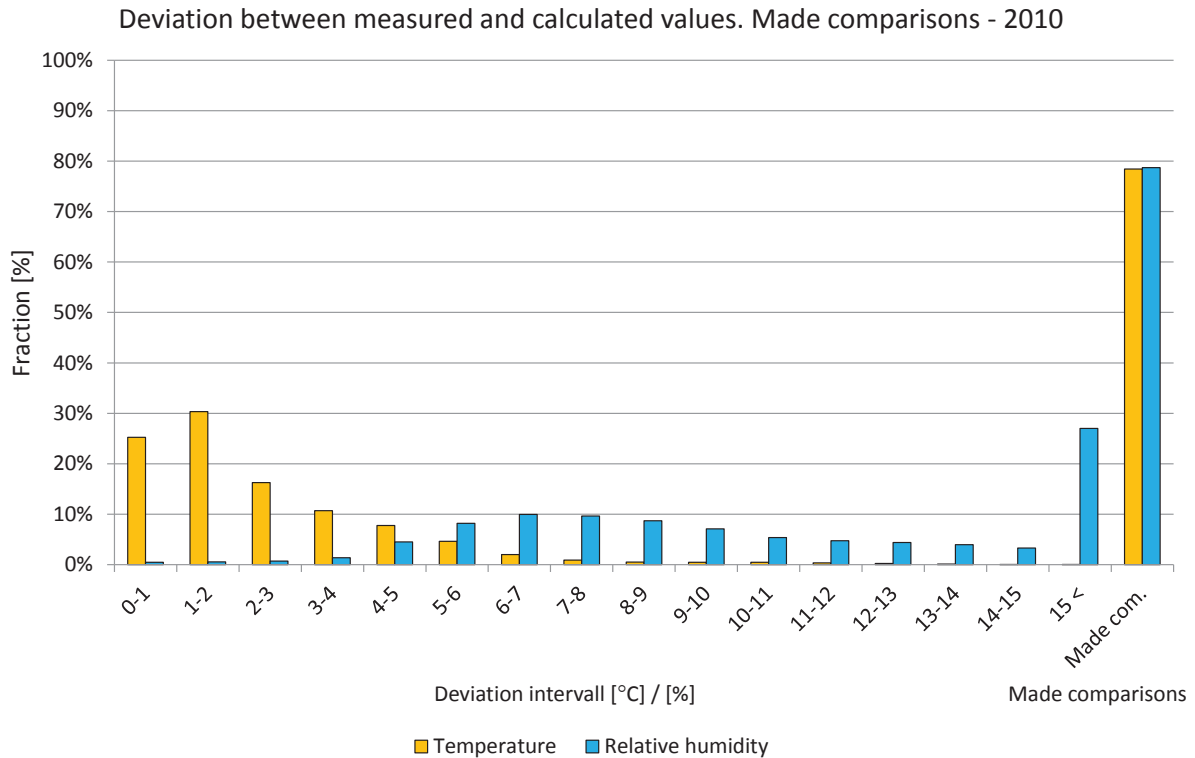

Figure 7.10.11. Deviations in comparisons shown in intervals from 0 to 15 °C or %. The two right-hand bars show the percentage of comparisons during the year. Temperature (yellow) and relative humidity (light blue).

**Year 2011**

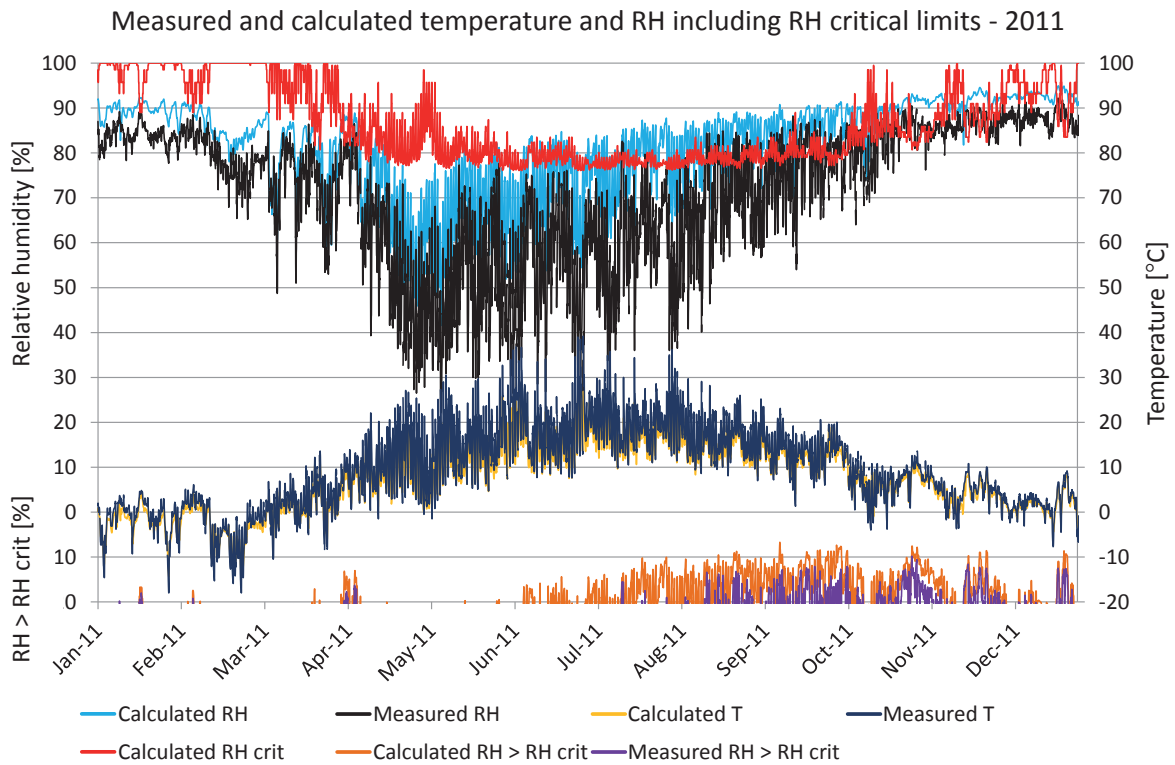

Figure 7.10.12. Comparisons between measured and calculated temperature and relative humidity. Calculated temperature (yellow), measured temperature (dark blue), calculated RH (turquoise), measured RH (black),  $RH_{crit}$  for calculated values (red), calculated  $RH > RH_{crit}$  (light brown), measured  $RH > RH_{crit}$  (purple).



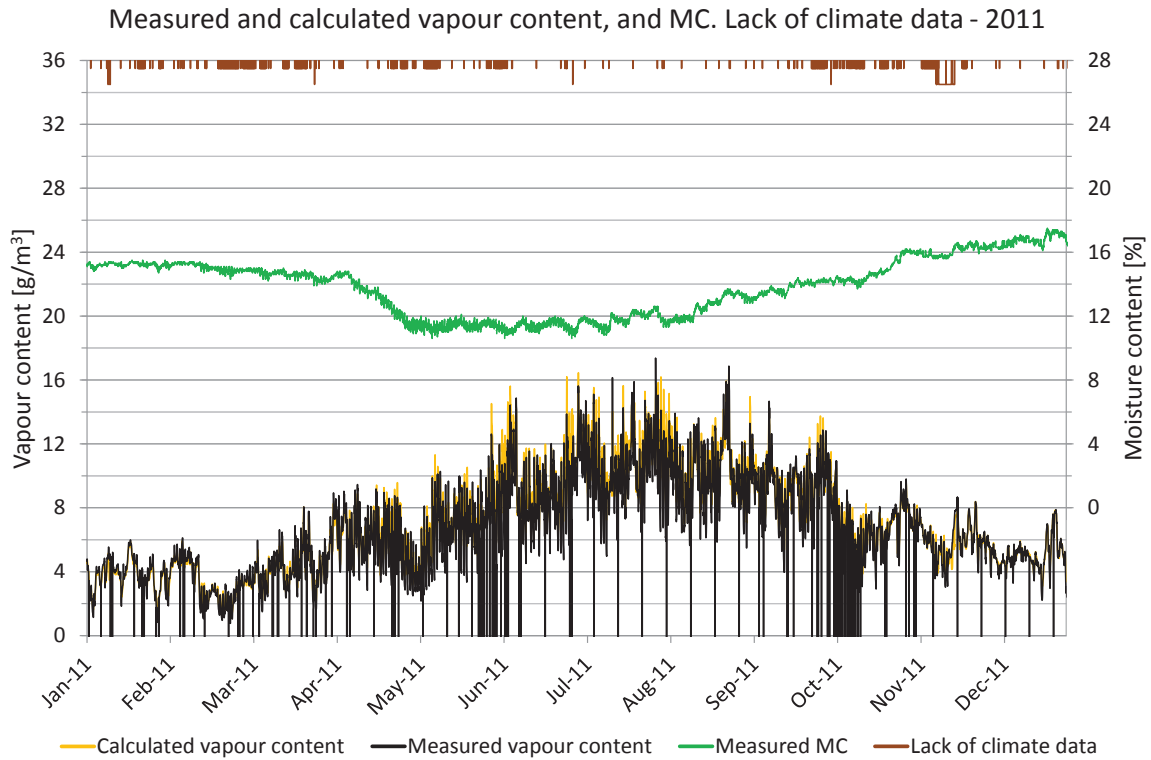

Figure 7.10.13. Measured moisture content, periods lacking climate data and comparisons of vapour content. Vapour content for calculated values (yellow) and measured values (black). Moisture content (green), periods with lack of climate data (brown).

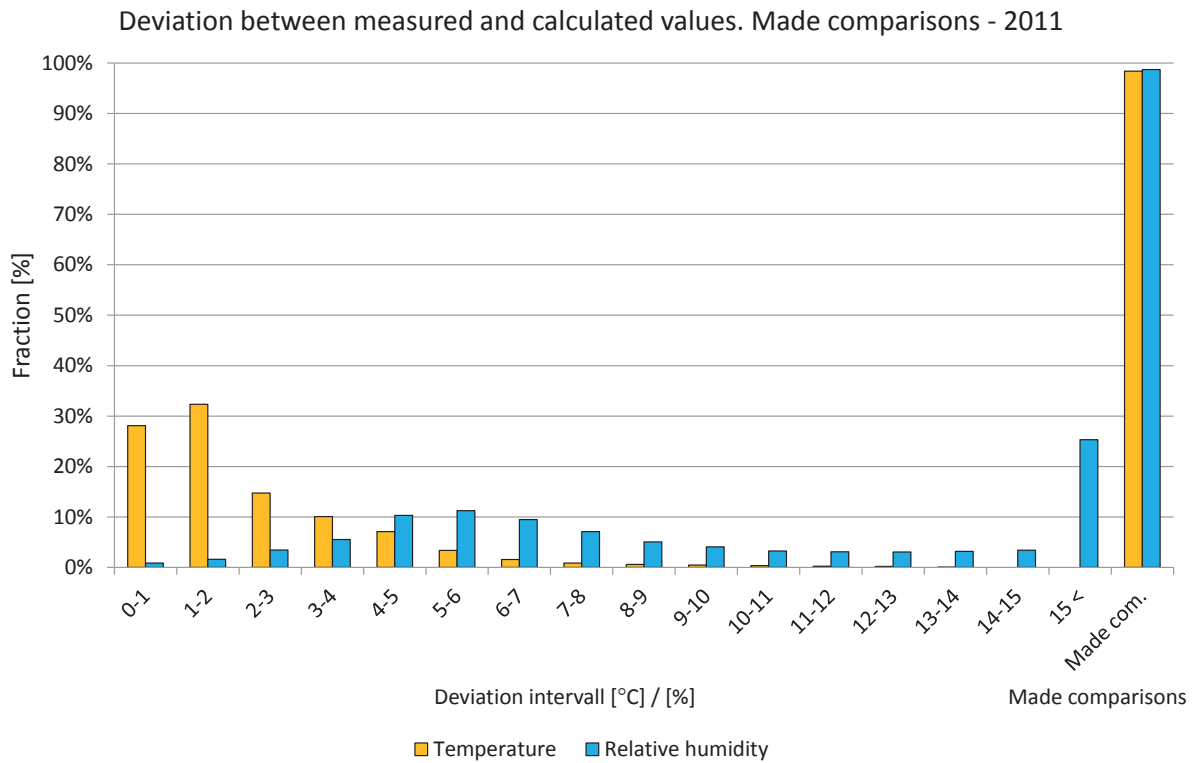

Figure 7.10.14. Deviations in comparisons shown in intervals from 0 to 15 °C or %. The two right-hand bars show the percentage of comparisons during the year. Temperature (yellow) and relative humidity (light blue).



## 7.11 Position 11

The locations of the measured and calculated position are shown in the drawings and figures below. The studied position is located in a wall facing northeast in the connection between the slab and the wall.

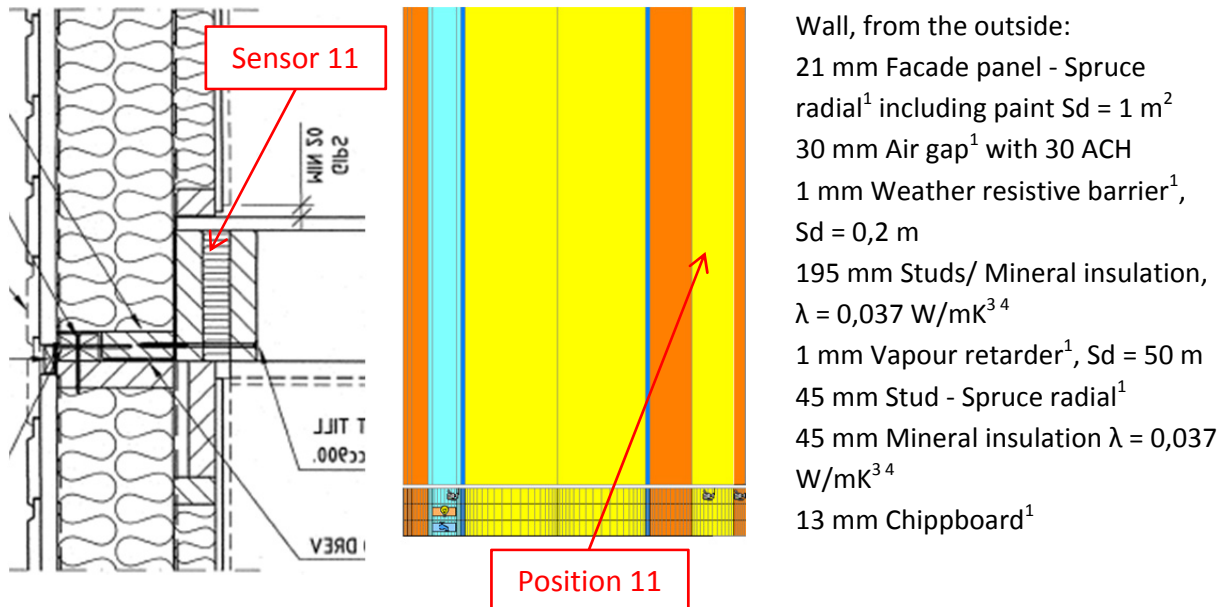

Figure 7.11.1. Vertical cross sectional drawing and WUFI calculation model showing the studied position. 1. IBP, 2012, 2. Nevander, L-E., 1994, 3. IEA Annex 24, 1996, 4. Paroc, 2002, 5. Krus, M., 1996.

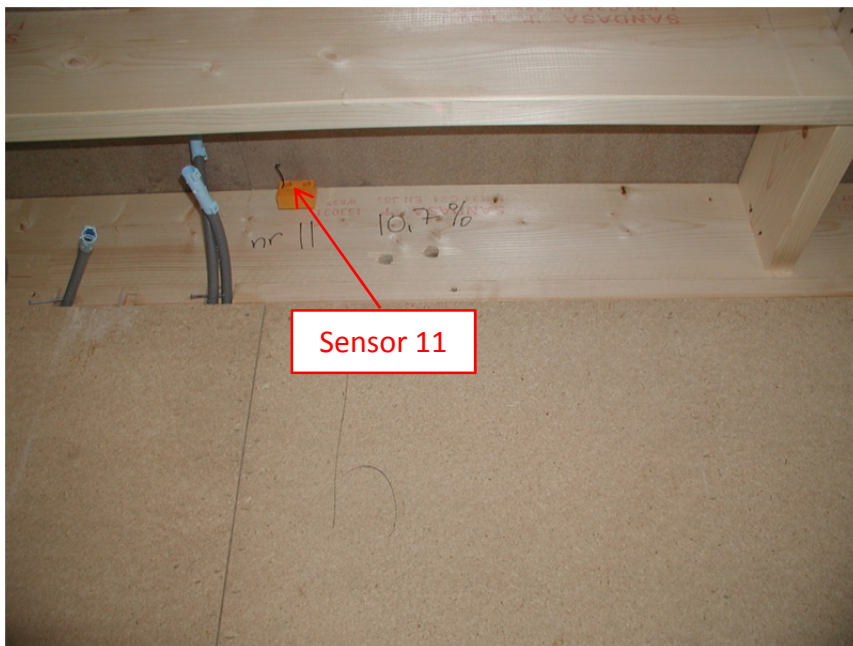

Figure 7.11.2. Location of the studied position.

A perfect match between the measured and calculated values cannot be expected due to e.g. the influence of two- and three-dimensional effects and the accuracy of the sensors.

**Year 2008**

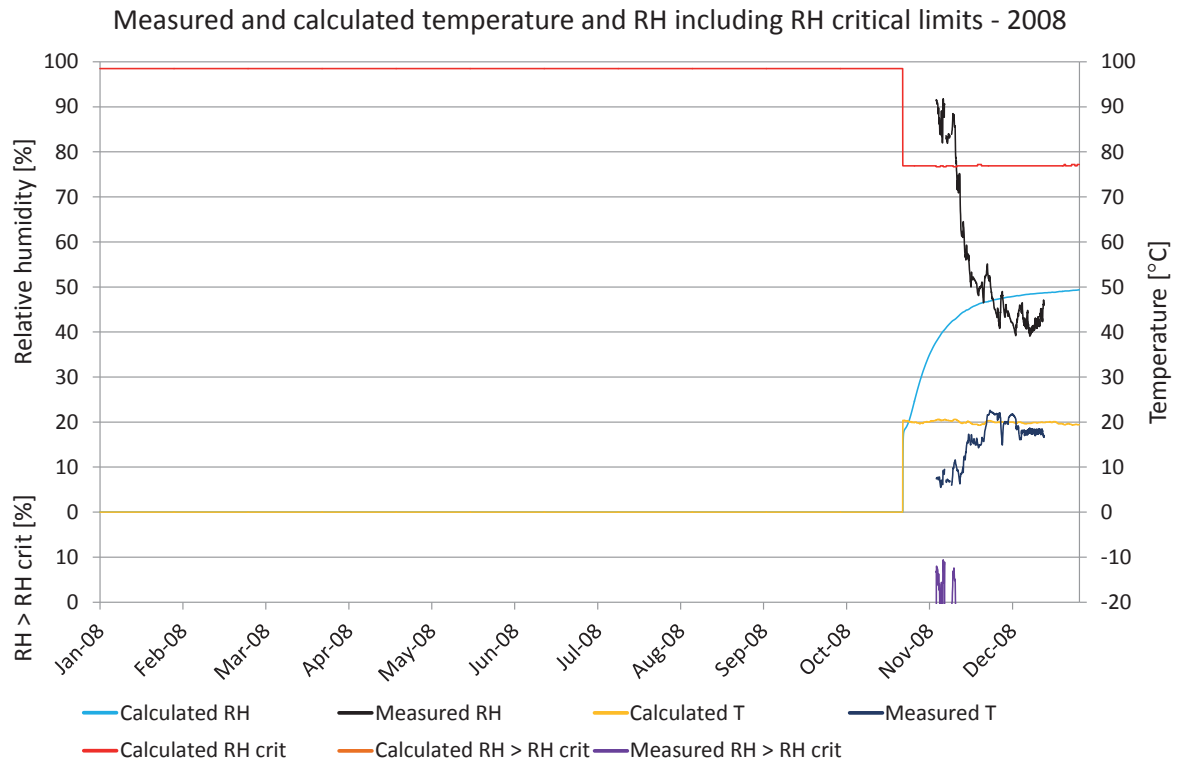

Figure 7.11.3. Comparisons between measured and calculated temperature and relative humidity. Calculated temperature (yellow), measured temperature (dark blue), calculated RH (turquoise), measured RH (black),  $RH_{crit}$  for calculated values (red), calculated  $RH > RH_{crit}$  (light brown), measured  $RH > RH_{crit}$  (purple).

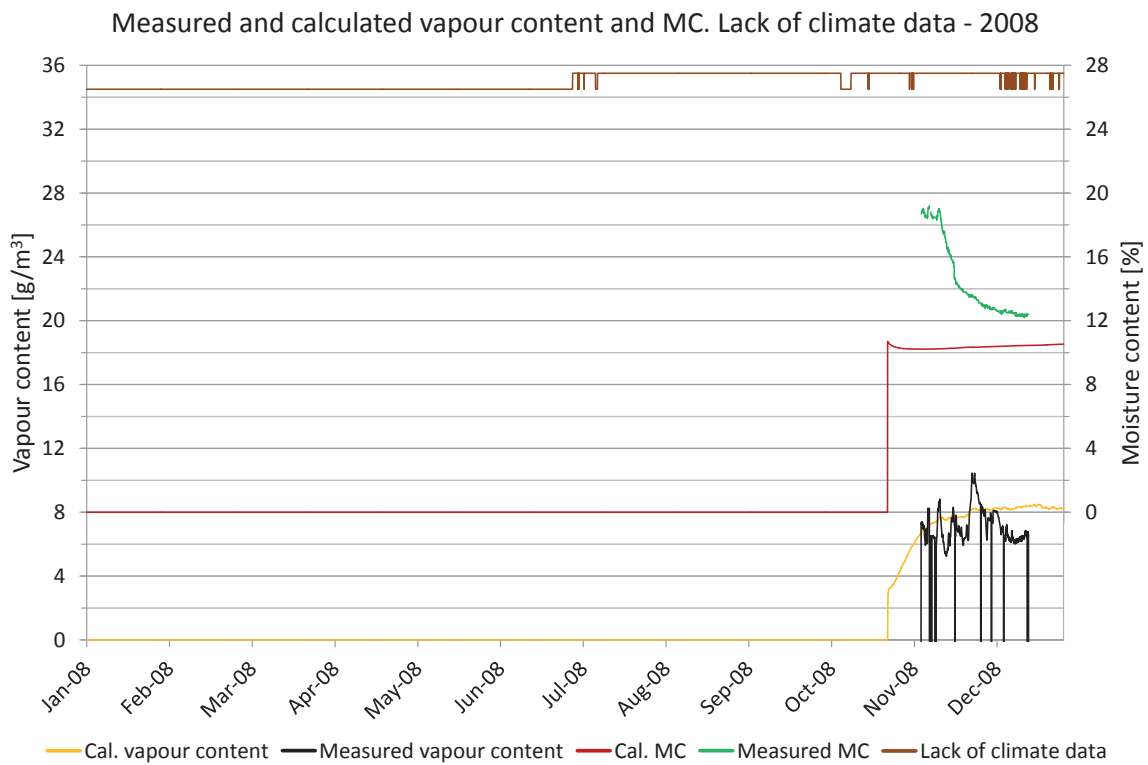

Figure 7.11.4. Measured moisture content, periods lacking climate data and comparisons of vapour content. Vapour content for calculated values (yellow) and measured values (black). Moisture content for calculated values (red) and measured values (green), periods with lack of climate data (brown).

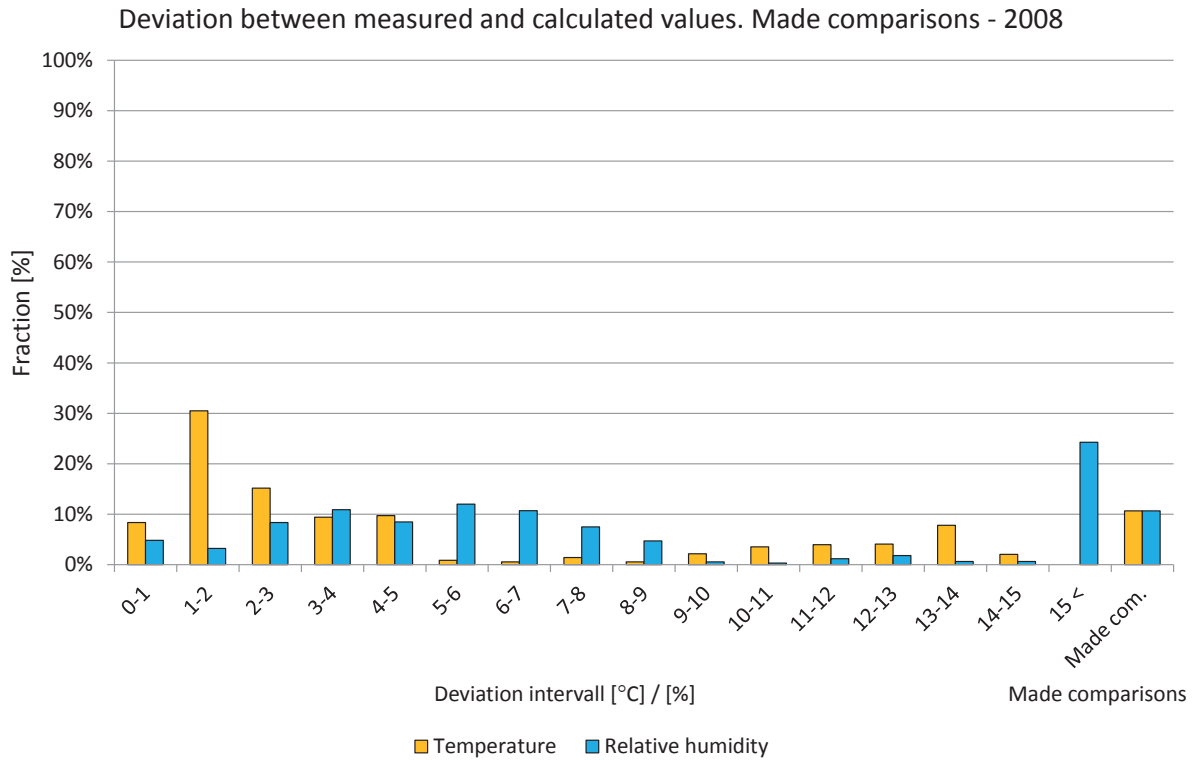

Figure 7.11.5. Deviations in comparisons shown in intervals from 0 to 15 °C or %. The two right-hand bars show the percentage of comparisons during the year. Temperature (yellow) and relative humidity (light blue).

**Year 2009**

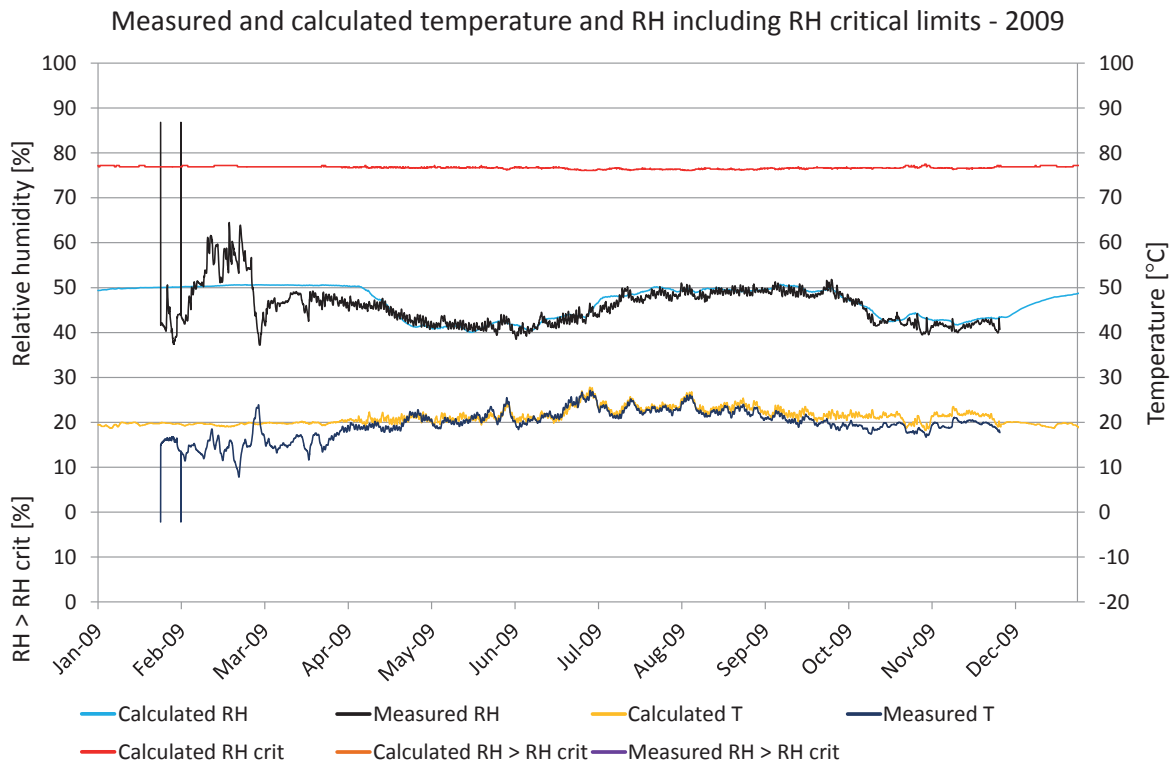

Figure 7.11.6. Comparisons between measured and calculated temperature and relative humidity. Calculated temperature (yellow), measured temperature (dark blue), calculated RH (turquoise), measured RH (black),  $RH_{crit}$  for calculated values (red), calculated  $RH > RH_{crit}$  (light brown), measured  $RH > RH_{crit}$  (purple).

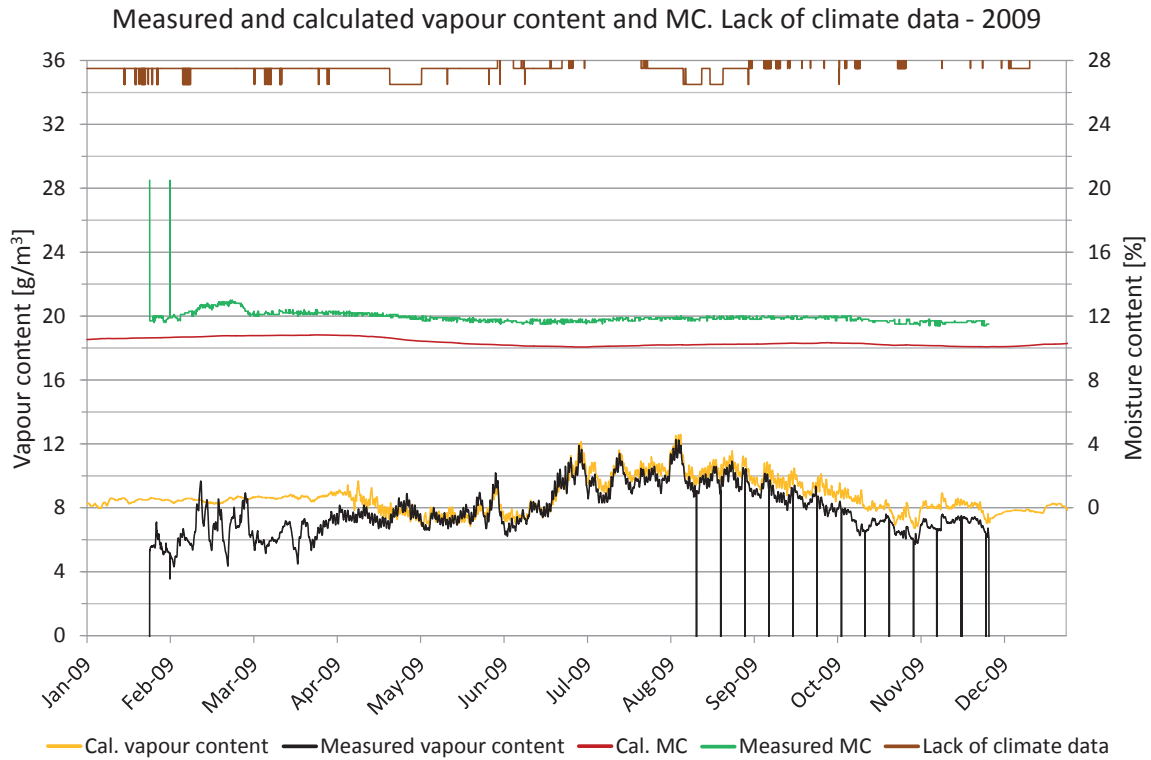

Figure 7.11.7. Measured moisture content, periods lacking climate data and comparisons of vapour content. Vapour content for calculated values (yellow) and measured values (black). Moisture content for calculated values (red) and measured values (green), periods with lack of climate data (brown).

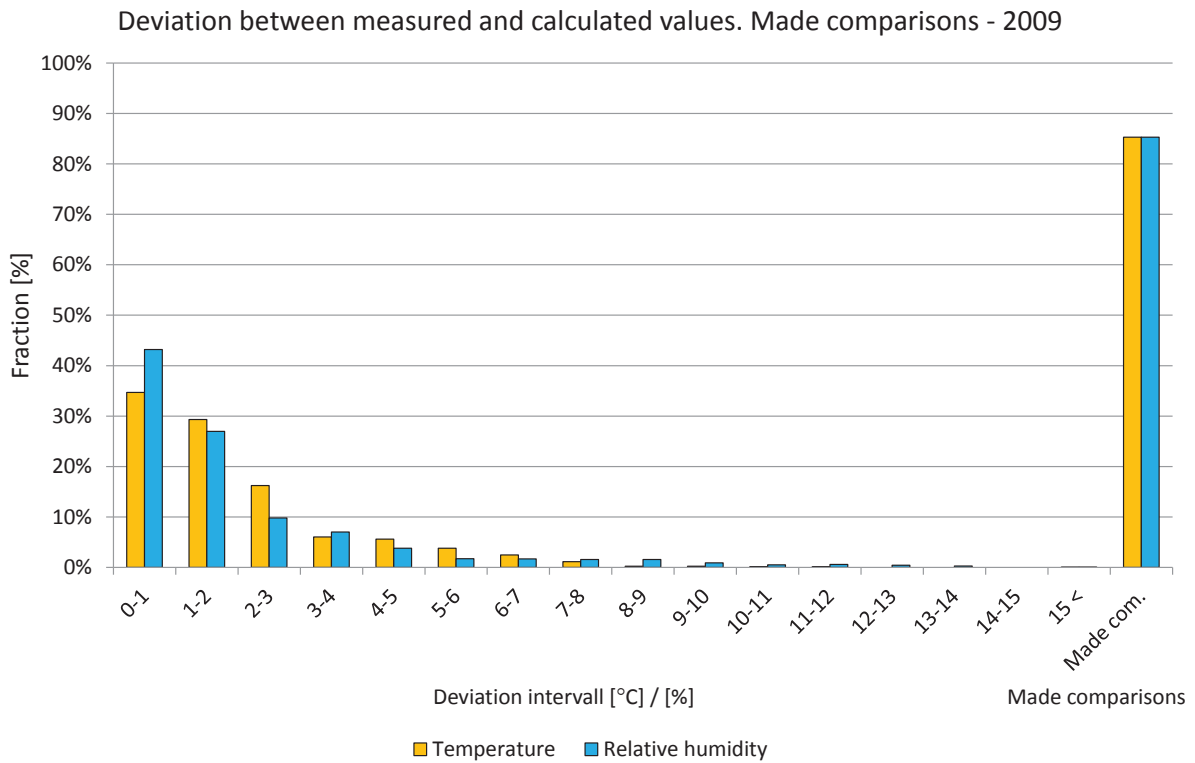

Figure 7.11.8. Deviations in comparisons shown in intervals from 0 to 15 °C or %. The two right-hand bars show the percentage of comparisons during the year. Temperature (yellow) and relative humidity (light blue).

**Year 2010**

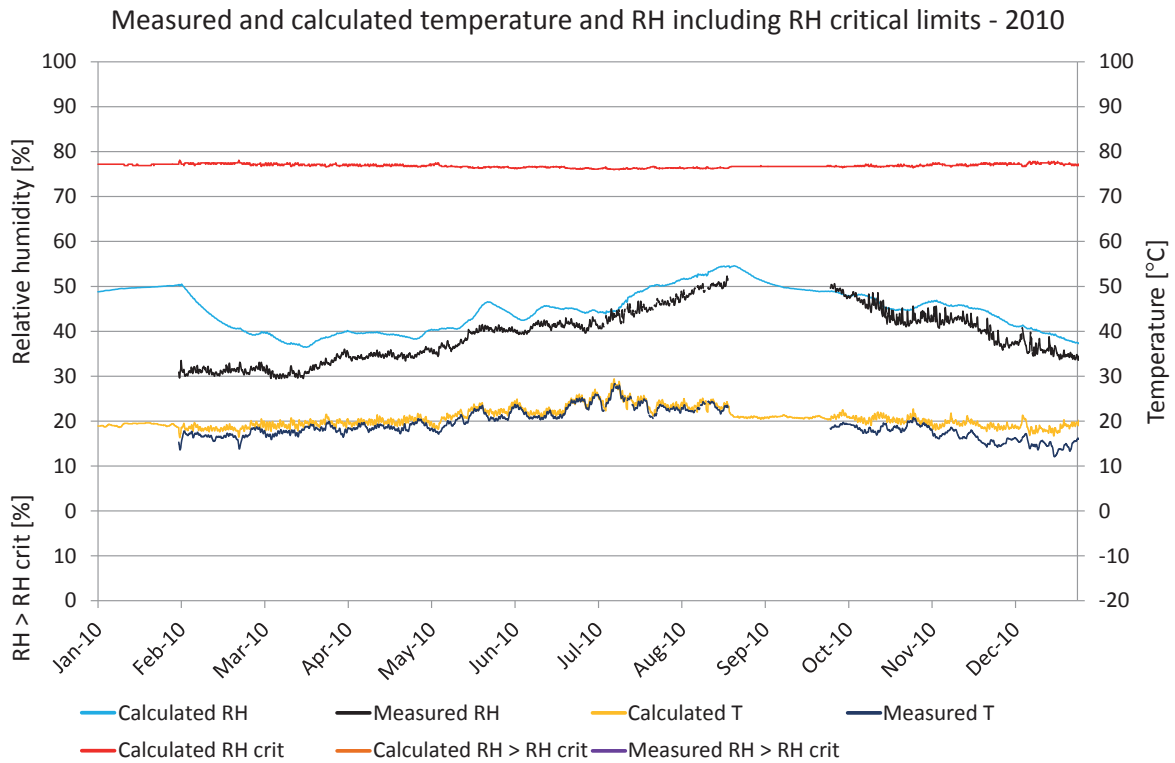

Figure 7.11.9. Comparisons between measured and calculated temperature and relative humidity. Calculated temperature (yellow), measured temperature (dark blue), calculated RH (turquoise), measured RH (black),  $RH_{crit}$  for calculated values (red), calculated  $RH > RH_{crit}$  (light brown), measured  $RH > RH_{crit}$  (purple).

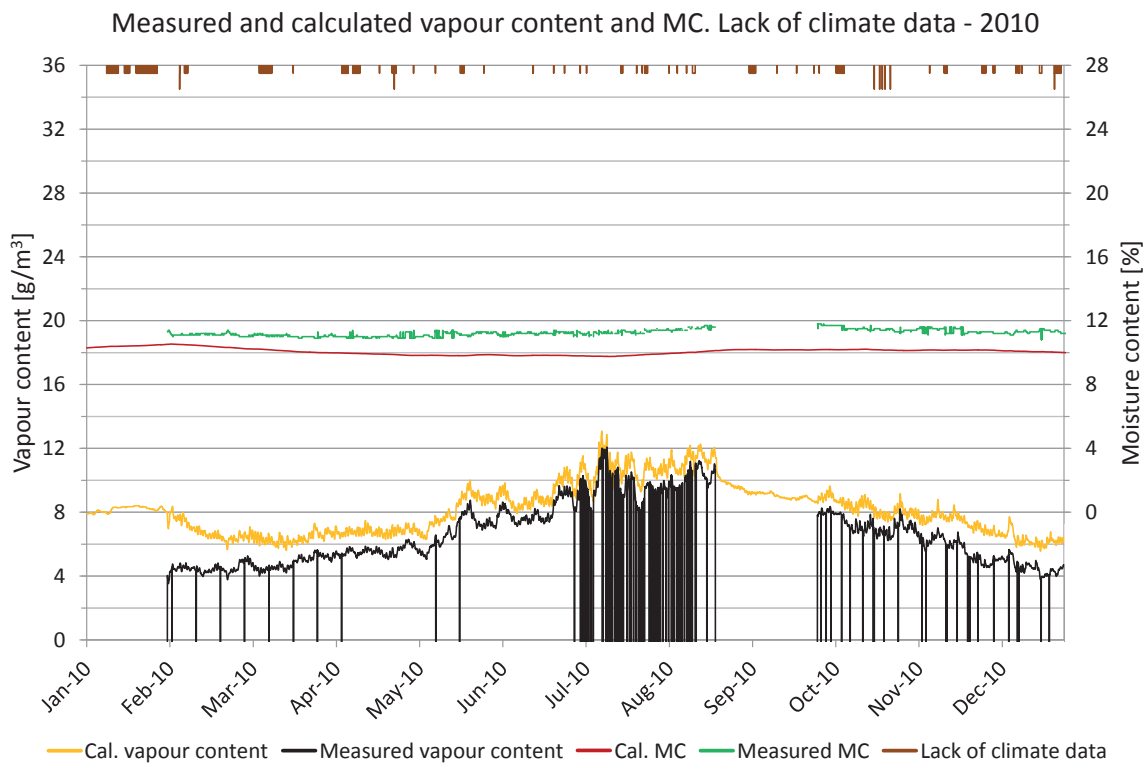

Figure 7.11.10. Measured moisture content, periods lacking climate data and comparisons of vapour content. Vapour content for calculated values (yellow) and measured values (black). Moisture content for calculated values (red) and measured values (green), periods with lack of climate data (brown).

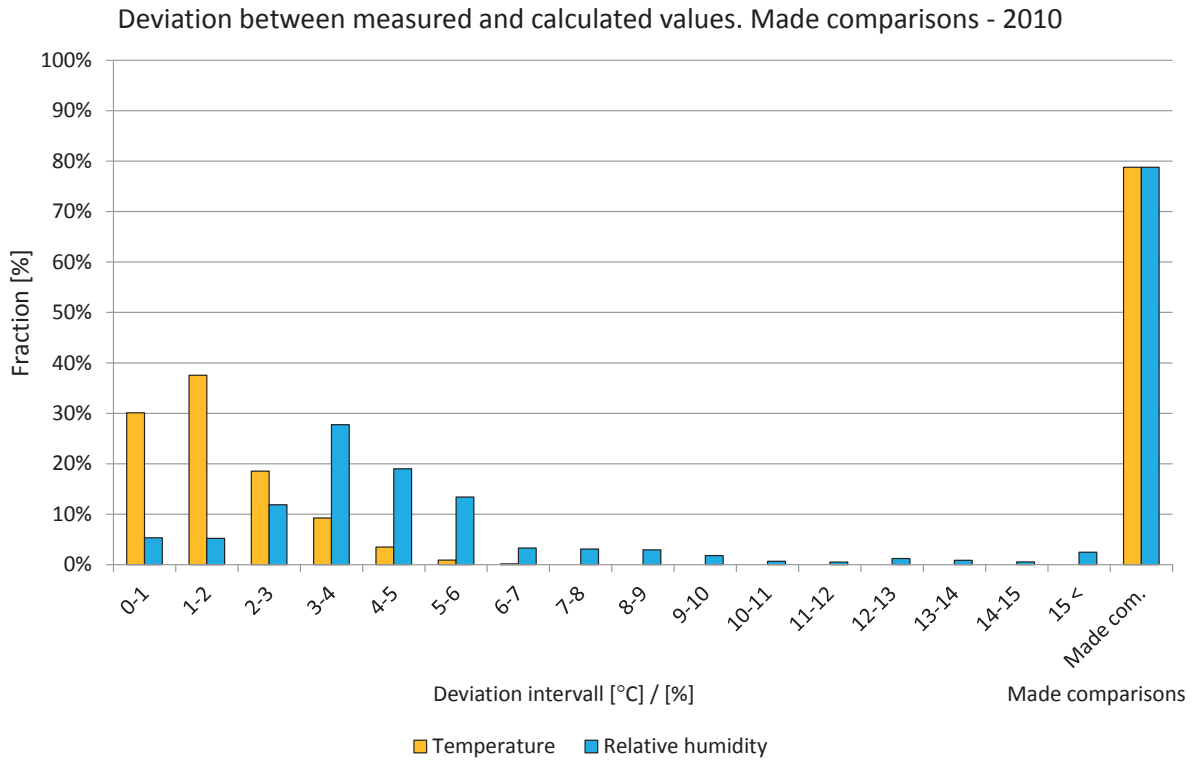

Figure 7.11.11. Deviations in comparisons shown in intervals from 0 to 15 °C or %. The two right-hand bars show the percentage of comparisons during the year. Temperature (yellow) and relative humidity (light blue).

### Year 2011

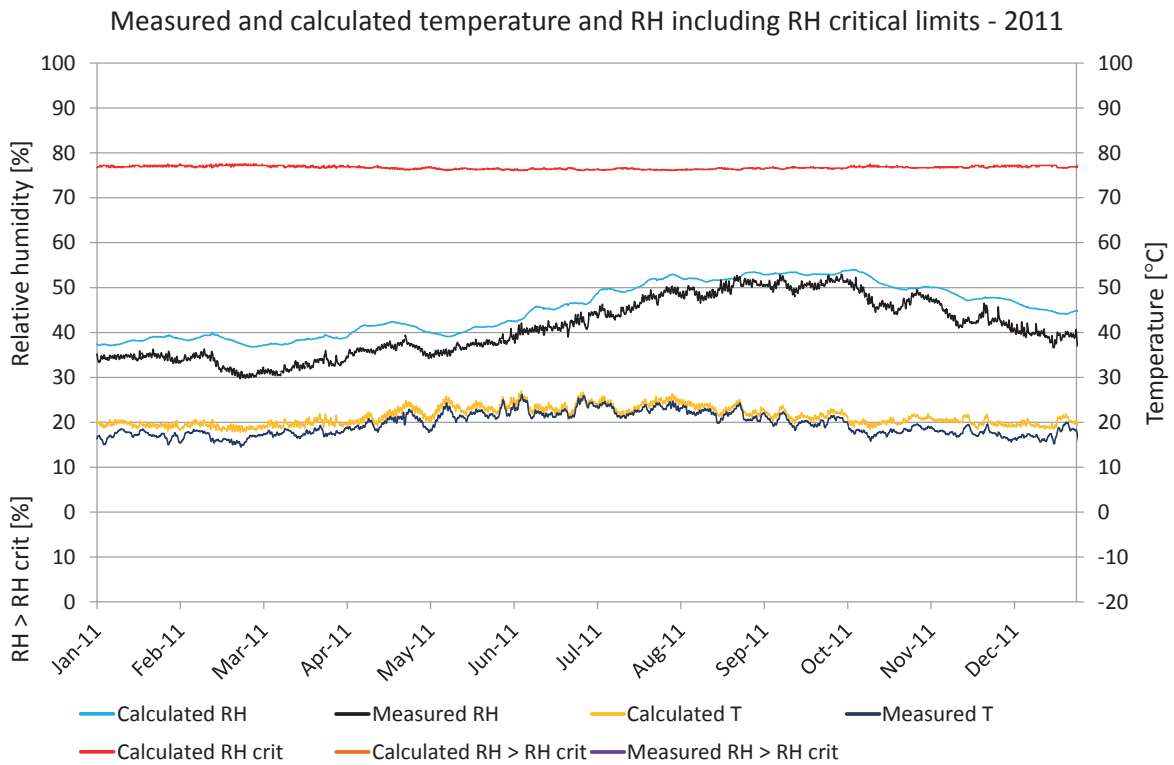

Figure 7.11.12. Comparisons between measured and calculated temperature and relative humidity. Calculated temperature (yellow), measured temperature (dark blue), calculated RH (turquoise), measured RH (black),  $RH_{crit}$  for calculated values (red), calculated  $RH > RH_{crit}$  (light brown), measured  $RH > RH_{crit}$  (purple).



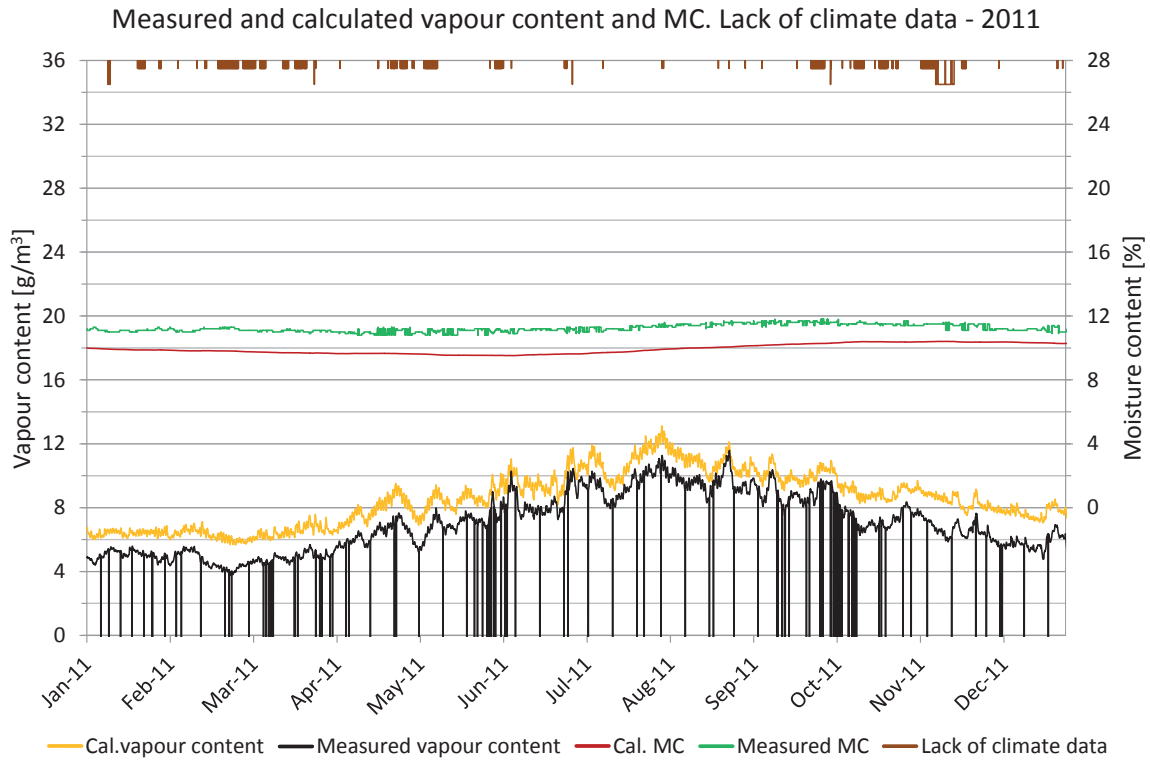

Figure 7.11.13. Measured moisture content, periods lacking climate data and comparisons of vapour content. Vapour content for calculated values (yellow) and measured values (black). Moisture content for calculated values (red) and measured values (green), periods with lack of climate data (brown).

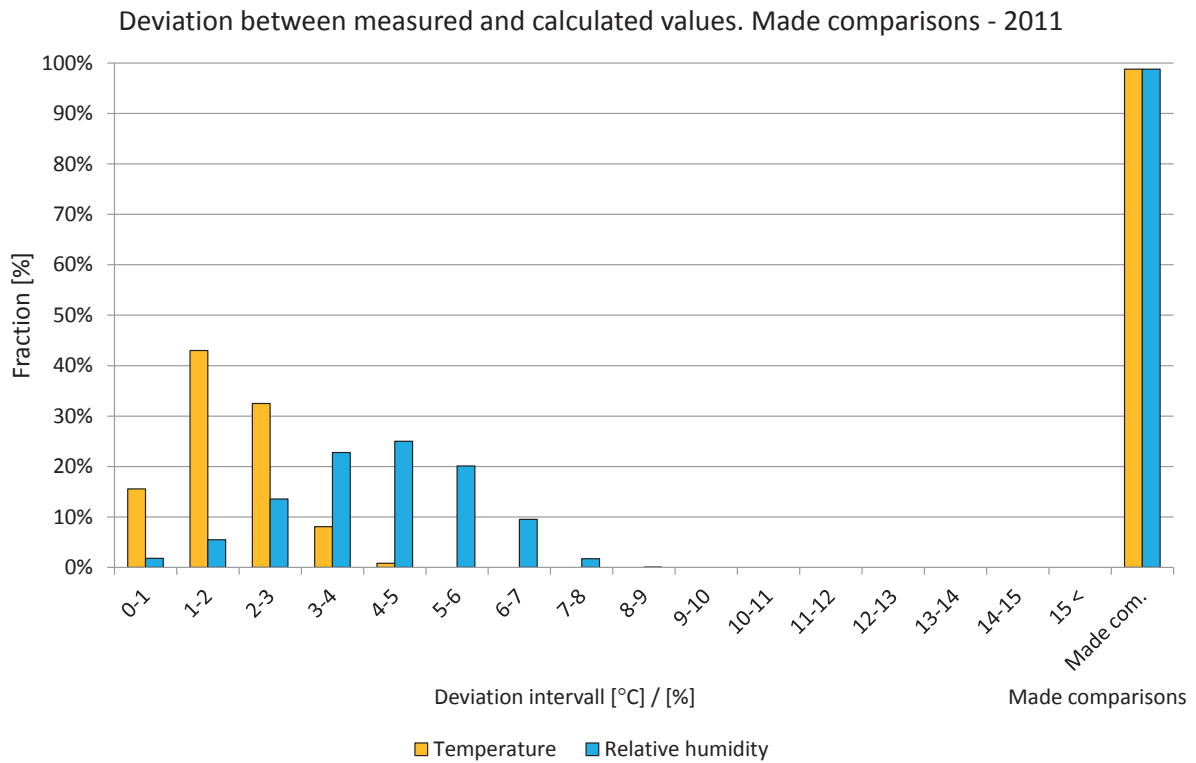

Figure 7.11.14. Deviations in comparisons shown in intervals from 0 to 15 °C or %. The two right-hand bars show the percentage of comparisons during the year. Temperature (yellow) and relative humidity (light blue).

