



LUND UNIVERSITY

On the Relation between Air void system parameters and Salt frost scaling

Lindmark, Sture

Published in:

Freeze-thaw testing of concrete - input to revision of CEN test methods : workshop proceeding from a Nordic miniseminarDic

2010

[Link to publication](#)

Citation for published version (APA):

Lindmark, S. (2010). On the Relation between Air void system parameters and Salt frost scaling. In D. Bager (Ed.), *Freeze-thaw testing of concrete - input to revision of CEN test methods : workshop proceeding from a Nordic miniseminarDic* (Vol. 9, pp. 41-58). Nordic Concrete Federation.

Total number of authors:

1

General rights

Unless other specific re-use rights are stated the following general rights apply:

Copyright and moral rights for the publications made accessible in the public portal are retained by the authors and/or other copyright owners and it is a condition of accessing publications that users recognise and abide by the legal requirements associated with these rights.

- Users may download and print one copy of any publication from the public portal for the purpose of private study or research.
- You may not further distribute the material or use it for any profit-making activity or commercial gain
- You may freely distribute the URL identifying the publication in the public portal

Read more about Creative commons licenses: <https://creativecommons.org/licenses/>

Take down policy

If you believe that this document breaches copyright please contact us providing details, and we will remove access to the work immediately and investigate your claim.

LUND UNIVERSITY

PO Box 117
221 00 Lund
+46 46-222 00 00

On the Relation between Air void system parameters and Salt frost scaling



Sture Lindmark
M.Sc., Ph.D.
Lund University
Div Building Materials
Box 118
221 00 LUND
E-mail: sture.lindmark@byggtek.lth.se

ABSTRACT

An attempt to develop a tool based on analysis of the air void system in concrete for an early assessment of salt frost scaling resistance of concrete is presented. Relations between the air void system parameters and scaling are discussed. A new technique based on the accumulated surface area of all air voids is presented. This is a short description of the project. The full report is available from our division and also includes a) a study of the rate of water absorption at above-knick point level in capillary suction tests, b) a technique for improving the image analysis procedure with respect to edge objects and c) a comparison between different ways of analyzing the air void system.

Key words: Frost resistance, air void, image analysis.

1. INTRODUCTION

In large construction projects, the client often demands that concrete shall be resistant to saltfrost scaling. Often, this resistance is tested according to SS 13 72 44. This test method requires one month of concrete curing before testing, and then the test runs for two months (four months if the concrete contains silica fume). Thus results are obtained three (or five) months after casting. The problem is that while the test is in progress, more concrete is cast and there is an obvious risk that a large amount of concrete of insufficient quality is cast before test results are at hand. In the worst case, concrete of insufficient quality is built in so that it cannot be replaced.

This happened in a large project some years ago, when the contractor made changes in the concrete composition because the fine contents of the gravel made it possible to reduce the cement content. Then, the air void system changed in such a way that the concrete no longer would pass the salt frost scaling test.

Because this is a problem that might become expensive for the contractor, the Development Fund of the Swedish Construction Industry (SBUF) (an association for Swedish contractors) ordered a development project from Lund University, division of Building Materials in 1999. This report gives a brief description of that project.

2. AIM

The aim of the project was to develop a method with which the contractor would be able to make his own quality assessment one or two days after casting, *i.e.* he would not have to wait a long time for results from the scaling test. Because the air void system, in contrast to the capillary pore system, is fixed once the concrete hardens, it seemed reasonable that an analysis of the air void system would be a suitable tool for this assessment.

Previously, the overall air content, the Powers' spacing factor and/or the specific surface of the air voids have been used for quality assessment as regards salt frost scaling. It was assumed that none of these alone would provide the information needed with good enough accuracy. Instead, the assessment would be based on a combination of these or other parameters.

In this project, the scaling test was performed according to a slightly modified version of the SS 13 72 44 (in order to save labour and time). Thus the results from the project (the relation between scaling and combinations of air void system parameters) were not expected to hold true in a full test according to SS 13 72 44. The intention was that if the project turned out successfully, the assessment methodology would later be modified to fit results from the SS 13 72 44.

3. METHODS AND REALISATION

The main principle was to produce a large amount of concretes with different types of air void systems and then compare the outcome of salt frost scaling test with the air void system parameters.

3.1 Concrete materials

Concretes of two water cement ratios were used; 0.40 and 0.50. The air void systems were varied by adding various amounts of air entraining agent and by vibrating the moulds in four different ways, including – in some cases – vibration one hour after casting. The 0.40 concrete was produced with 10 different dosages of AEA, which, multiplied by four different ways of combining vibration and plasticizer, resulted in 40 different air void systems. For various reasons 2 of these were discarded and thus 38 air void systems of w/c 0.40 were investigated. In the same way, the 0.50 concrete was produced with 20 different systems. Thus, in total, 58 concretes were cast and tested.

The concretes were mixed in batches of 140 l. Four blocks of size 400×300×250 (mm³) were cast of every concrete: A: heavy vibration, B: modest vibration, C: modest dosage of plasticizer, and finally one block (D) with a high dosage of plasticizer.

Cylinders were drilled from the cast blocks and then discs were sawn for saltfrost scaling test, image analysis and capillary suction tests, see fig 1.

For further details please see the original report [1].

Table 1: Basic mix compositions for concretes used in the study (no plasticizer). These mixes were varied by adding more or less air entraining agent and plasticizer.

Water cement ratio:	0.40	0.50
Cement ("Anläggning") Dens 3200 kg/m ³	512.5	410
Water	205	205
Gravel 0-8 mm (Åstorp kvartsit)	919.85	967.38
Stone 8-12 mm (Hardeberga kvartsit)	722.74	760.09

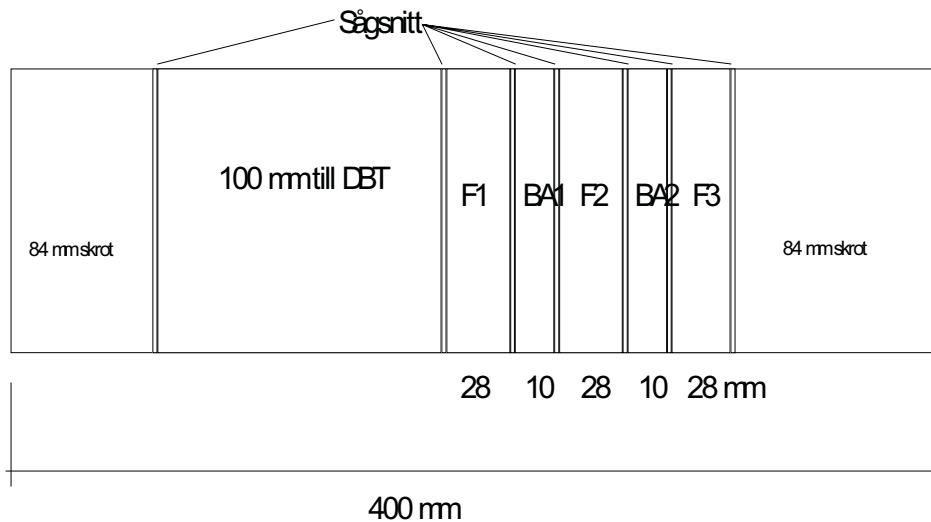

Figure 1: Distribution of samples in drilled out cores from the cast blocks: Width of saw cuts 4 mm, total core length: 400 mm. F: Sample for scaling test, BA: Sample for image analysis. Image analysis performed on BA1. Capillary suction test performed on BA2. ("100 mm till DBT" indicates which part was sent to Dansk Beton Teknik for air void system analysis by linear traverse, "Sågsnitt" = saw cut)

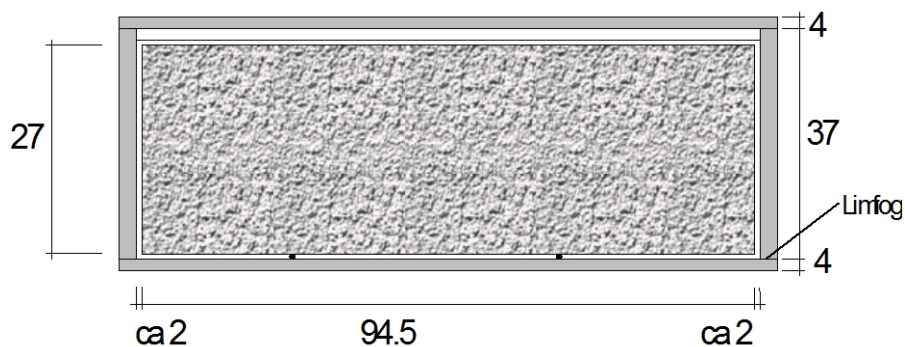

Figure 2: Set-up for the modified salt frost scaling test: Samples were placed in PVC containers, supported by 2 mm high studs. The lid, of PVC, is laid loose on top of the container. ("Limfog" = glued joint)

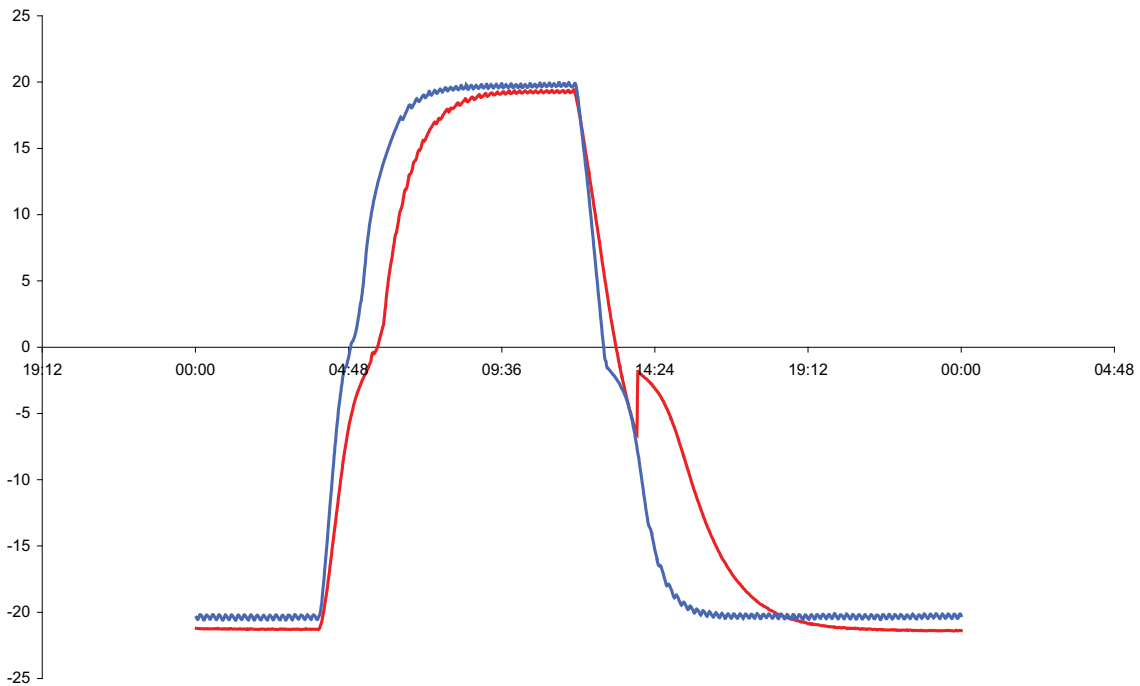

Figure 3: Temperature cycle. The two curves shown are data collected from two different samples. The difference somewhat reflects the spread in temperature cycle between different samples which is due partly to the randomly varying super cooling.

3.2 Scaling test

A complete test according to SS 13 72 44 was not possible due to lack of time. Also, the risk of leakage was estimated to be too high and thus a more reliable container had to be used. The modified setup is shown in Figure 2.

The samples were circular discs (diameter 94 mm, thickness some 27 mm). Three samples were used for every air void system. Samples were stored in lime water until one week before start of test. Then they were taken up, weighed and dried for 22 ± 2 hours at $18^\circ\text{C}/38\%\text{RH}$, weighed, imbibed in water for 5 minutes, taken up and wrapped in plastics. Then the samples were left to somewhat even out moisture gradients for four days. From 46 ± 2 hours before start of test the samples were placed in water until start of test. Right before starting the test, the samples were once again weighed.

The temperature cycle was measured in the NaCl solution on top of some of the samples, see Figure 3.

Each frost cycle lasted 24 hours. 28 cycles were run. Scaling were collected every seven cycles.

The minimum temperature is lower than in the SS 13 72 44 (some -21°C instead of -18°). During cooling and thawing, the temperature change is more rapid than described in the standard.

After 28 cycles, so many samples were so badly damaged that a continuation was no longer meaningful. Thus the tests were interrupted.

Because the test method deviates from the standard method, the acceptance criterion of the standard cannot be used.

3.3 Air void analysis procedure

Discs of concrete were cut out from the cast blocks (Figure 1) and then ground and dyed with a blue background colour. The air voids then appear as circular, shallow cavities. These cavities are filled with a white paste to create a good contrast in black-white between background and air voids.

The prepared surface is then photographed (in black and white) in a microscope and presented on a computer screen. Each picture measures approximately $1.6 \times 1.6 \text{ mm}^2$. For each concrete quality, 250 pictures were taken. The resolution is such that each pixel on the computer screen corresponds to $3.1 \text{ }\mu\text{m}$. Examples of pictures are shown below (in a different magnification).

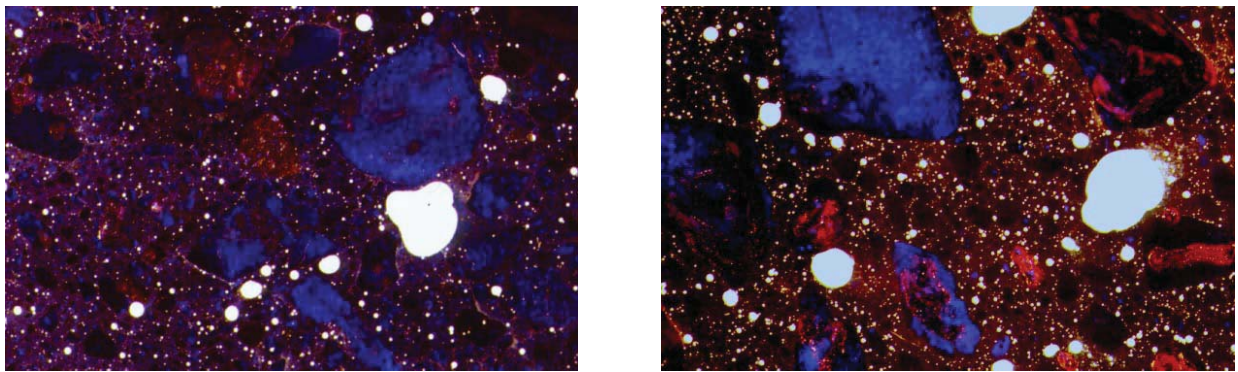

Figure 5: Example of samples for image analysis of air void systems
 Left: B1, air content 1.9%, Right: B3C air content 4.6%.
 Each picture shows an area of $24 \times 36 \text{ mm}^2$.

3.4 From 2D image to 3D volume: Calculation of air void system parameters

The photographs produce 2D representations of a 3D air void system. To calculate the properties of the original 3D system, a methodology according to Underwood [2] was used (also described by Vesikari [3]). For the sake of comparison and as a quality control, the air void systems were also analysed by linear traverse (Lord and Willis [4]) by Peter Laugesen at DBT, Dansk Betonteknik, Copenhagen.

The following is a brief description of the calculation procedure:

When slicing through a unit size cube of a concrete sample, the probability of hitting a sphere of diameter $D_i (=2R_i)$, is proportional to the diameter of that sphere:

$$P_{hit,i} = \frac{D_i}{l_{cube}} \quad (1)$$

where l_{cube} is the side length of the cube.

When slicing a plane through a unit size cube through a concrete sample containing a certain air void system, each void size interval i produces a number $n_{2d,i}$ of circles (2D projection of the cavities) on the plane which number is calculated as

$$n_{2d,i} = n_{3d,i} \times P_{hit,i} \quad (2)$$

The probability of cutting a sphere of radius R_i so that the diameter of the 2D circle is in the size class j ($d=2r_j$) is calculated (illustrated below):

$$P_{i,j} = \frac{(R_i^2 - r_j^2) - (R_i^2 - r_{j+1}^2)}{R_i} \quad (3)$$

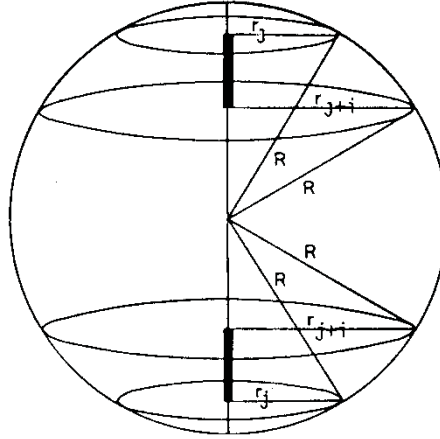

Figure 6: Illustration to calculations as given by Vesikari [3].

The number of 2D circles in circle size class j that is produced by spheres in sphere size class i thus is calculated as:

$$n_{2d,j} = P_{i,j} \times P_{hit,i} \times n_{3d,i} \quad (4)$$

The calculation of the complete air void size distribution is done by using these formulas in a matrix form, solving for $n_{3d,i}$.

The final product of these calculations is the probable number of spheres in size class i , *i.e.* the number of spheres of diameter in the interval between two sizes. (The Underwood/Vesikari method produces somewhat different results as compared to the method of Lord and Willis).

It might turn out that the calculated number of spheres in a certain size class is negative, which of course cannot be correct. This incorrect result occurs because the statistical ground is too small (too few pictures). The calculated numbers are corrected by subtracting the absolute number of spheres in the classes where negative values are received from the number of spheres in the size class of next larger spheres.

The treatment of identified objects is further described in the original report [1].

The calculation of 3D distributions of air voids is inherently associated with several difficulties. For instance, on the 2D image, spherical air voids will appear as perfectly circular cavities. However, many air voids are not perfect spheres, and thus their 2D-representations may be more

or less oval. In the extreme end, compaction pores create cavities which are far from circular. These imperfections are handled in the automated image analysis computer program by setting a criterion on different parameters of the cavities. For example, *Roundness* is one of the parameters which may be used to differentiate cavities which are likely to have come from spheres from cavities resulting from compaction pores etc.

In Figure 10, an example of the finally calculated air void distribution is presented, described as accumulated volume of air as a function of void size. Also seen in this figure is the effect of choice of the parameter *Roundness*, which is one of the parameters which can be used as a criterion for separating circles produced by true air voids from those circles produced by irregular voids. The parameter *Roundness* has the value 1.0 for perfect circles and 1.57 for squares. The choice of limiting value for this parameter is also dependent on the absolute size of the individual object (due to the way screen pixels represent objects). In the calculations, the value of *Roundness* was finally set to $R = 2.5$ (a lower value would discriminate objects which, by visual inspection, most likely to stem from voids which act protectively just like air voids. Recalculations with varying values can be made quite easily.

Finally, in the microscope image there are some circles in the plane which are cut by the frame of the image. Such edge objects disturb the calculated air void size distribution. A way of handling these objects is described in the original report.

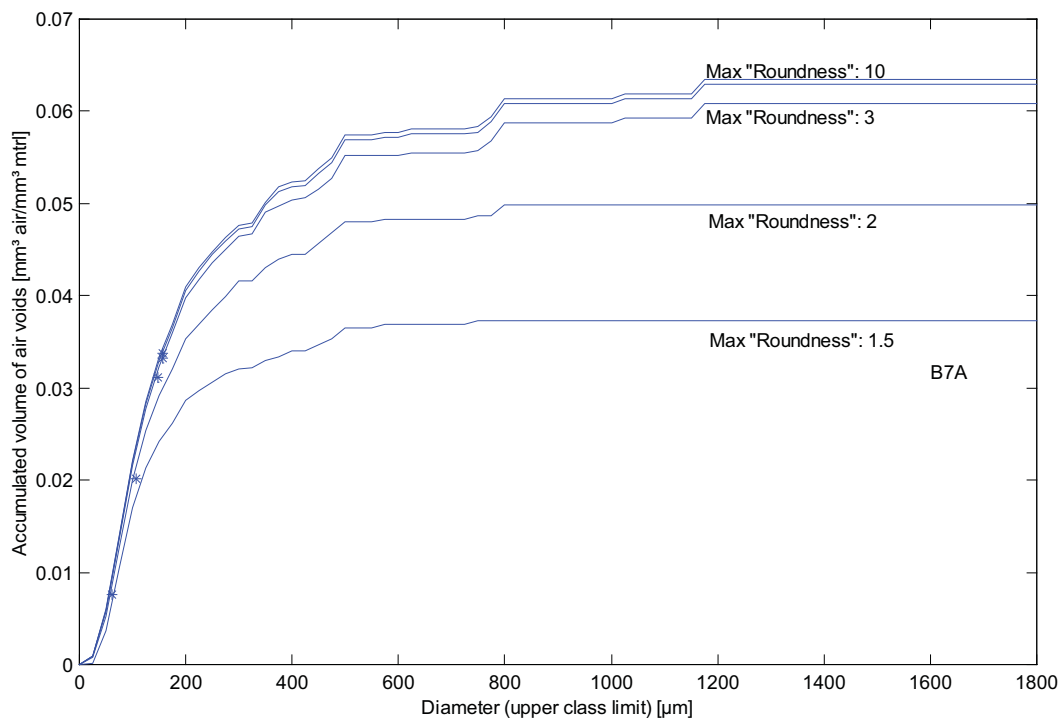

Figur 10: Effect of choice of value of parameter *Roundness* on calculated accumulated air content. Sample B7A (w/c 0.40), (not adjusted for edge objects).

4. RESULTS

4.1 Results from air void system analysis

The specific surface of air voids and/or air void systems may be defined in different ways. In this study, the specific surface is calculated as the total surface area of all (spherical) air voids, divided by their total volume:

$$\alpha = \frac{\sum_{d=0}^{\infty} n_d A(d)}{\sum_{d=0}^{\infty} n_d V(d)} \quad (5)$$

This equation produces a value which is not equal to that calculated according to Powers' definition (which is calculated under presumption that all voids are of the same size).

4.2 Results from scaling tests

The amount of scaling for each concrete type after 28 cycles is given in figures 13 and 14.

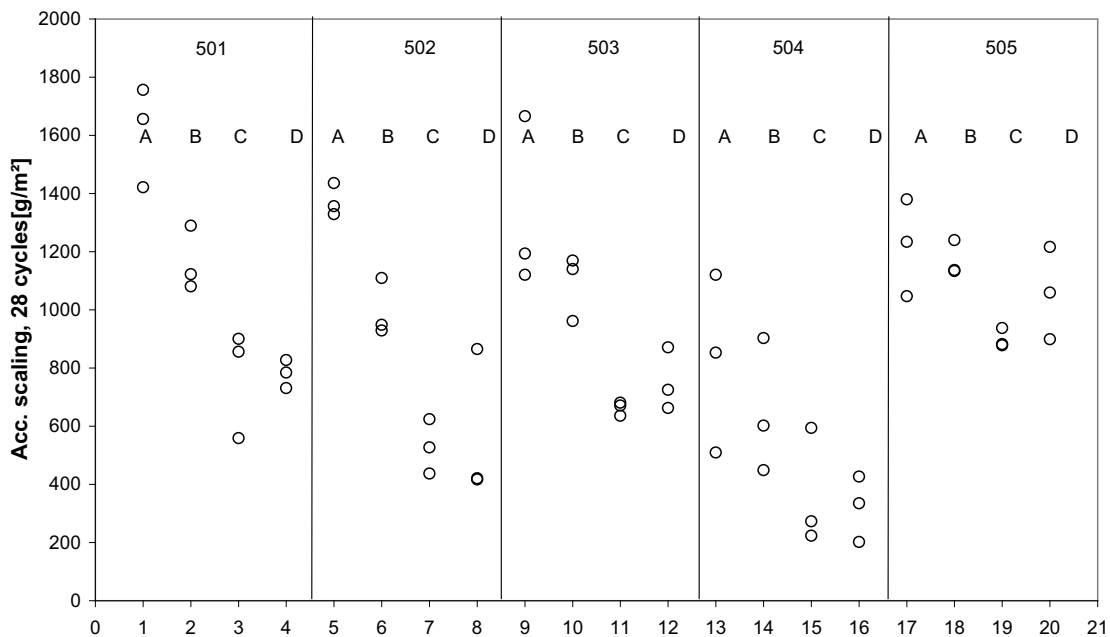

Figur 13: Spread in accumulated scaling (28 cycles) for concretes of w/c 0.50. For each concrete three samples were tested (=one ring). In cases where only two circles are visible, the third one is hidden by one of the other two.

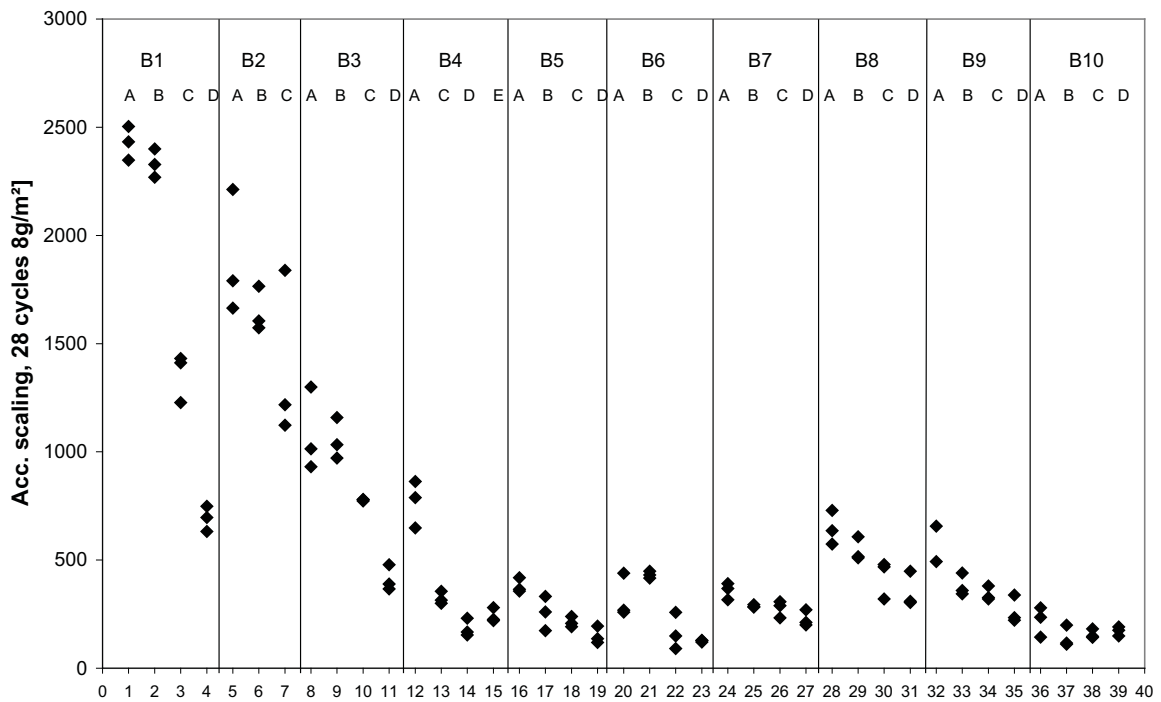

Figur 14: Spread in accumulated scaling (28 cycles) for concretes of w/c 0.40. (Concrete quality B2D was not tested.)

5. DISCUSSION

5.1 Relations between scaling and air void system parameters - "traditional way"

Scaling in relation to single air void system parameters

The traditional ways of seeking relations between air void system parameters and frost induced deterioration (pure frost or salt frost) is by plotting scaling vs. air content, specific surface of voids or Powers' spacing factor. Examples of such plots are given in figures 19-21. As seen in the figures, these relations are rather poor.

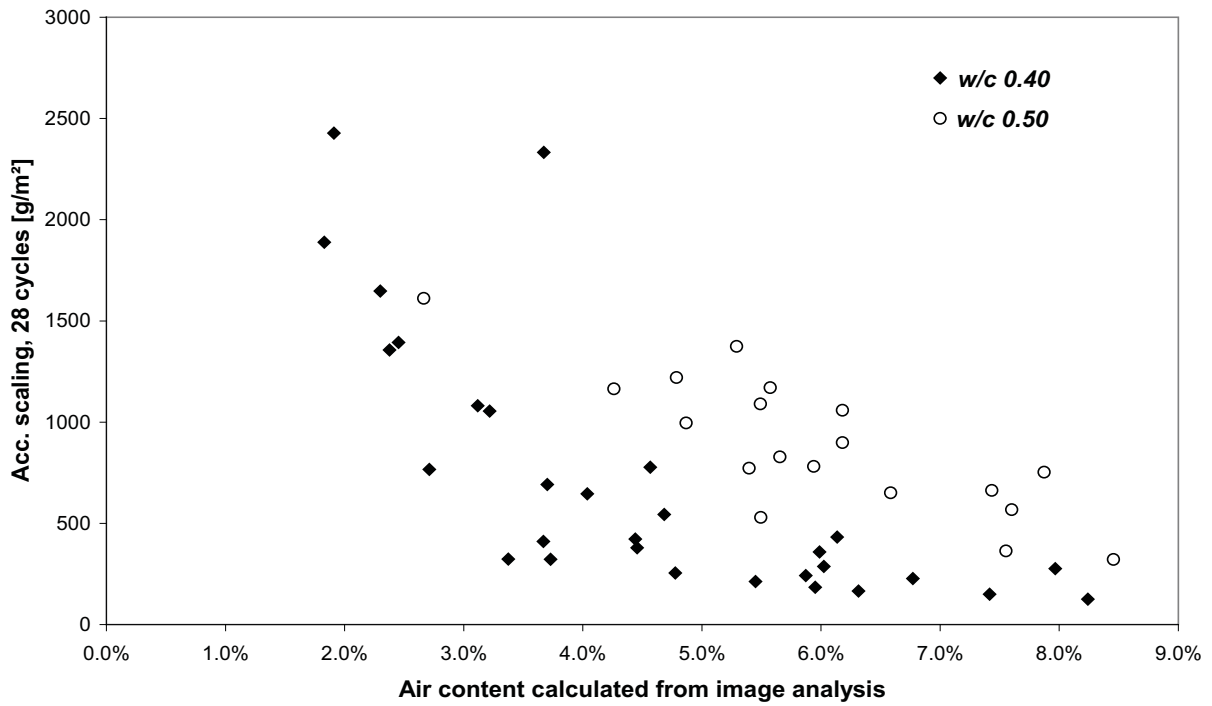

Figure 19: Accumulated scaling (mean of threesamples) vs. Total air content determined as accumulated air content in calculated air void size distribution.

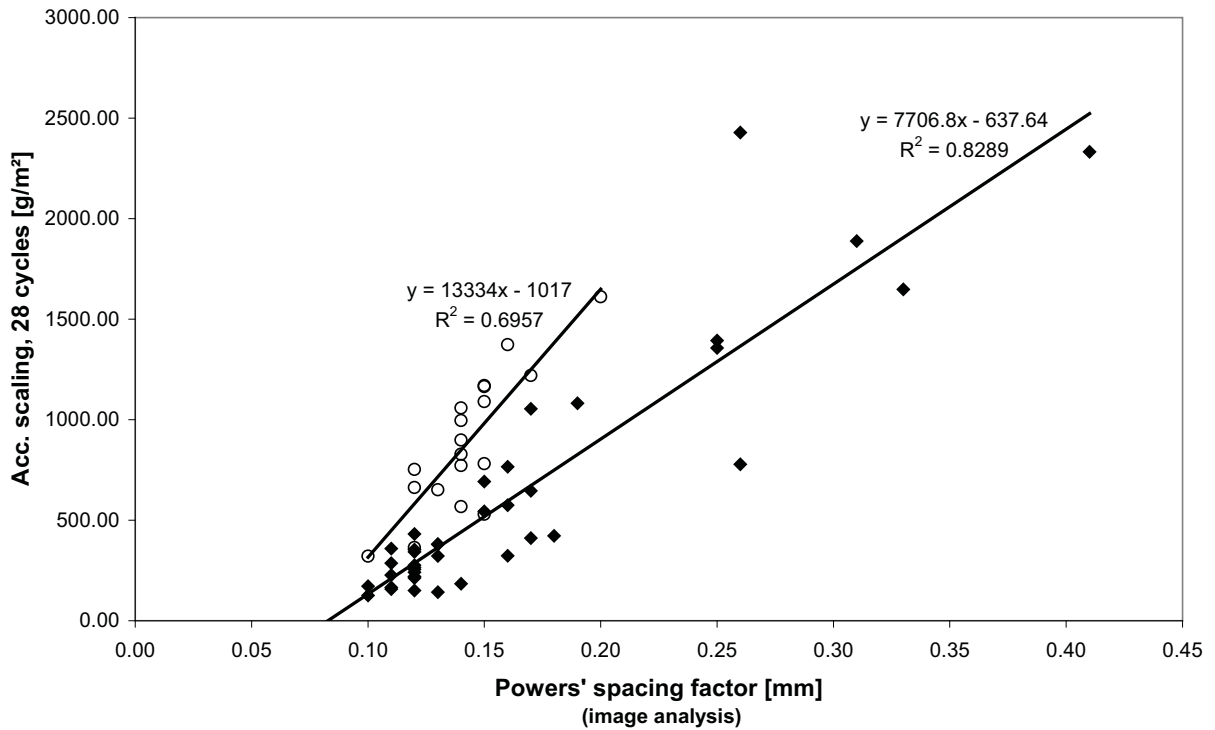

Figure 20a: Acc scaling (each dot = mean of three samples) vs. Powers spacing factor. Spacing factor determined from total calculated air content and with specific surface calculated acc. to eq 5.

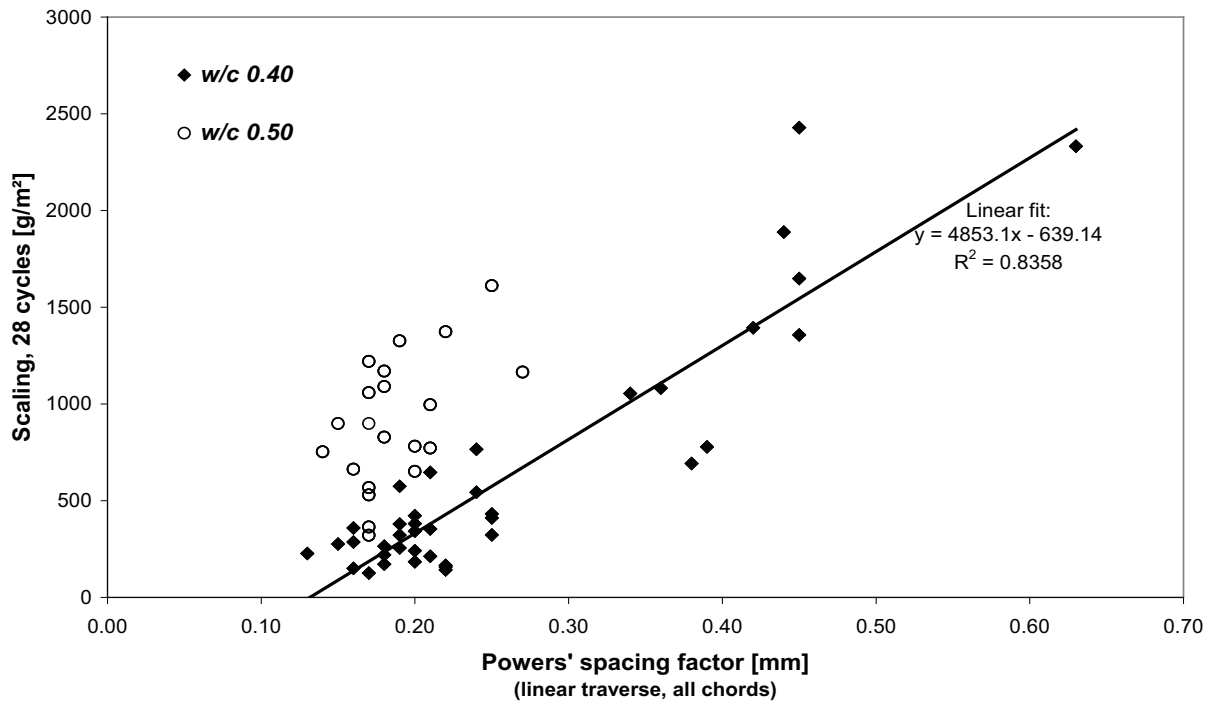

Figure 20b: Acc scaling (each dot = mean of three samples) vs. Powers spacing factor. Spacing factor determined acc. to ASTM C457 (linear traverse).

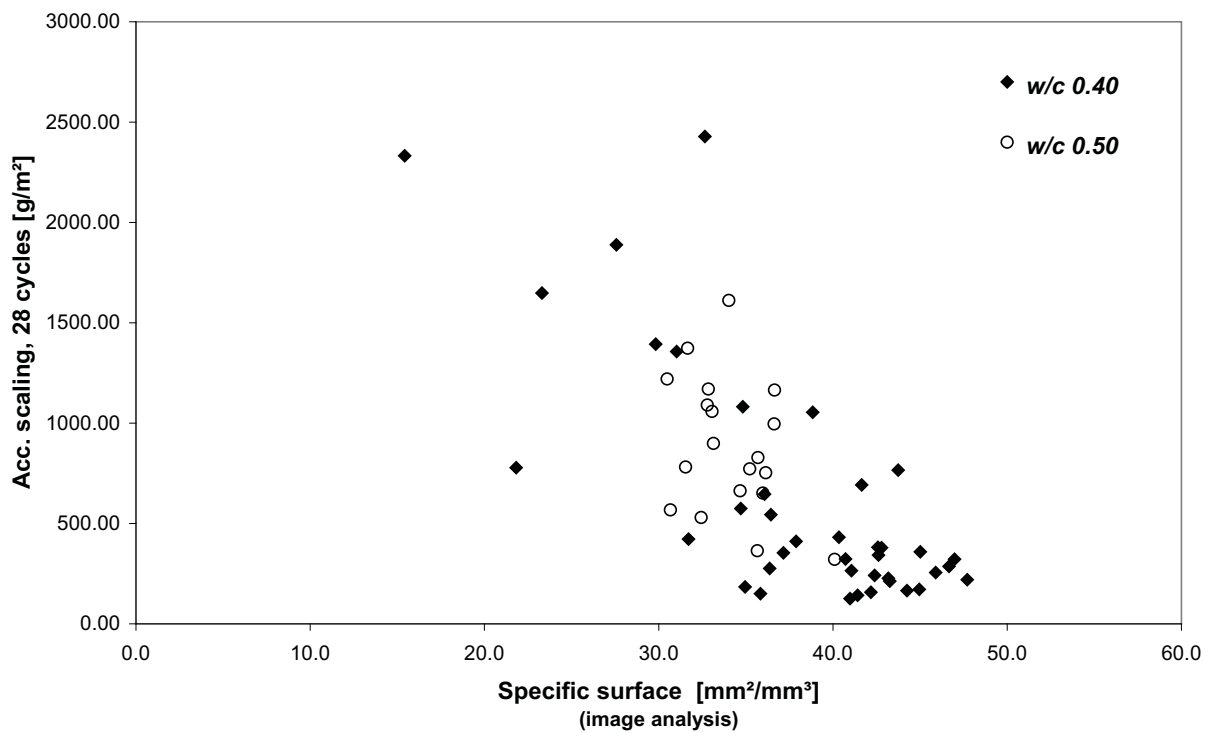

Figure 21: Accumulated scaling (mean of three samples) vs. specific surface of air void system acc. to eq 5.

According to Laugesen [5], Dansk Beton Teknik describes the quality of an air void system by determining the air content (as fraction of length of traverse crossing cavities) counting only

chords shorter than 350 μ m. Plotting accumulated scaling vs. this parameter produces the graph shown in figure 22. Apparently, there is a reasonably good correlation for the 0.40 concrete, but not for the 0.50 concrete.

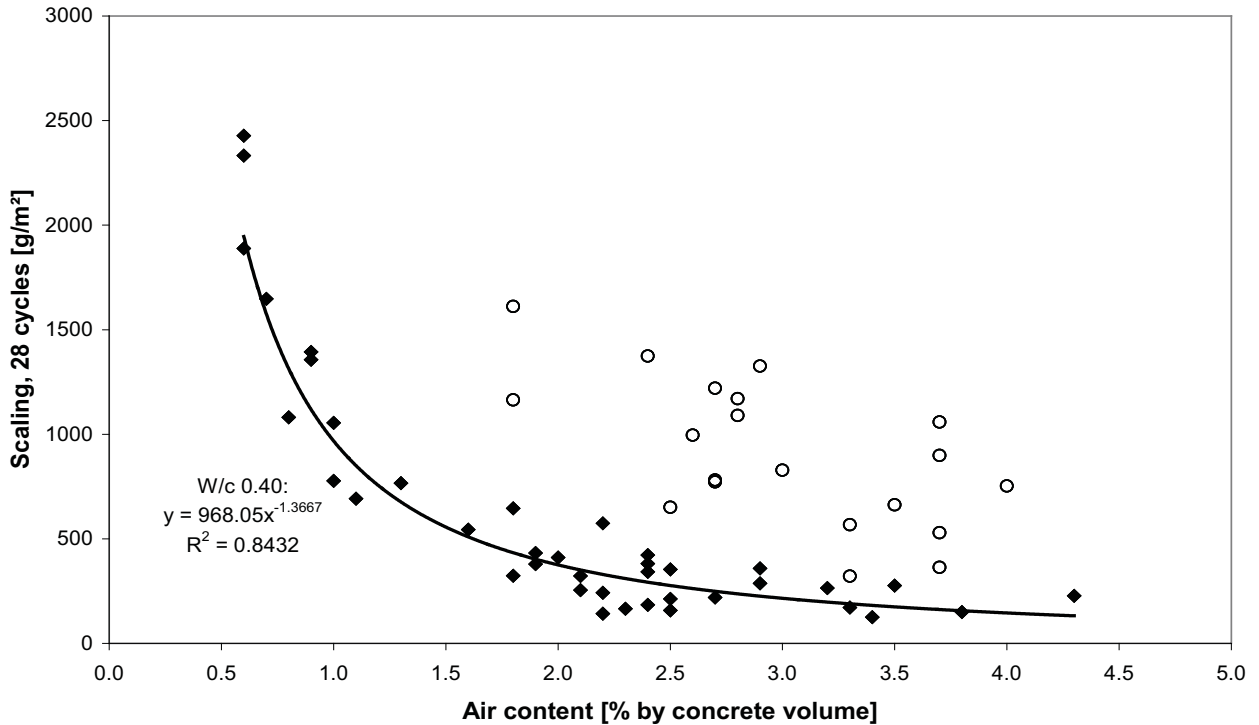

Figure 22: Accumulated scaling after 28 cycles (one dot = mean of three samples) vs air content as calculated fraction chords shorter than 350 μ m of total travers length.

Scaling in relation to combinations of parameters

As seen above, relating scaling to one, single air void system parameter tends to result in insufficient relations. Thus, one may try relating scaling to a combination of parameters. Different ways of doing this are shown in figures 23 and 24. In these figures, the amount of scaling is represented by the area of circles. (More examples are given in the original report.)

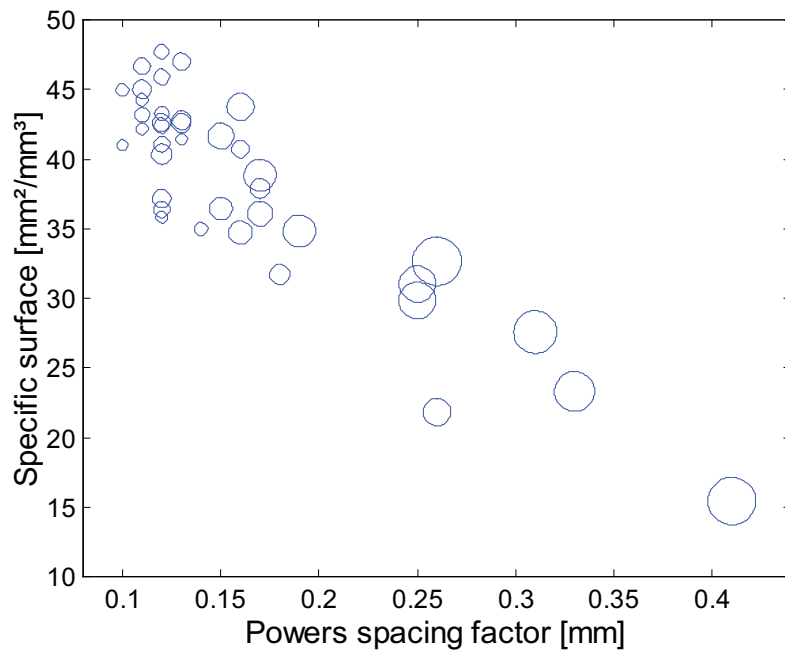

Figure 23 : Accumulated scaling ((28 cycles) for concrete of w/c 0,40 (represented relative to each other by the area of circles) in relation to specific surface (eq 5) and the Powers spacing factor.

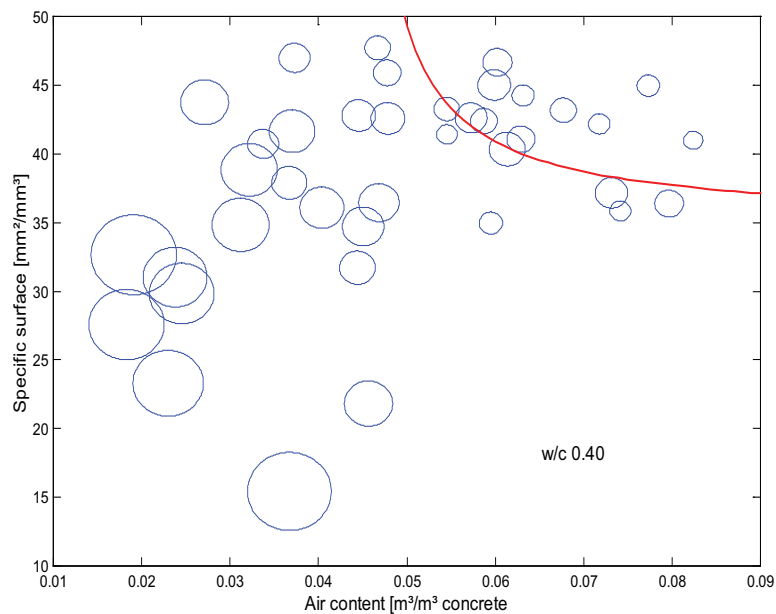

Figure 24: Amount of scaling (relative to each other, represented by area of circles) in relation to specific surface (eq 5) and total air content, w/c 0.40. Red line according to eq (6) with arbitrarily chosen parameters.

In figure 24, the amounts of scaling for different concrete qualities, expressed by the area of circles, are presented in relation to specific surface of air voids and to total air content. As seen, there is no very clear border line between different samples. However, considering the mechanisms of frost attack, one might expect that in a plot like this there should exist a lower

critical value for both specific surface and for total air content. Thus an equation of the following form may be set up:

$$(\alpha - \alpha_{crit})(L - L_{crit}) > k \quad (6)$$

in which k is some critical limit value which has to be derived from tests according to the appropriate test method (SS 13 72 44 or which other method is to be used).

In figure 24, a line has been drawn according to this equation. The parameters α_{crit} , L_{crit} and k were chosen arbitrarily to produce a line in an area that seemed reasonable. However, it is seen that the line may very well be drawn lower in the graph (*i.e.* the critical values for the respective parameters might be set lower). This kind of equation might be useful, but needs to be calibrated for the appropriate test method.

5.2 Some words about protective and non-protective voids

Which voids should be disregarded? Which voids have a protective effect with respect to frost attack? It cannot really be expected that a relation between salt frost scaling and parameters of the air void system as determined in a microscope analysis alone will be found. This is due to that some of the voids probably will become completely filled with water very quickly when the concrete is subjected to water [6], and some will become partly filled. Thus some of the air voids that are detected in the microscope do not have a protective effect. Such voids must be excluded when analyzing the relation between scaling and air void system parameters. The question of how to do this exclusion remains open. An attempt was made to study this: For concrete of w/c 0.40, scaling was plotted vs. total air content in voids of diameter $D > 250 \mu\text{m}$, fig 25. The relation is not very good, and for w/c 0.50 it is even worse. A continued experimenting with choice of limiting void sizes might have proven successful. However, since we know only little about the process of water filling of air voids (*e.g.* we do not know for sure whether small voids are completely filled before larger ones start filling), it is difficult to make a rational choice of limiting void size, and because there are uncertainties in the determination of air void size distributions, it is meaningless to carry this study any further in this text. (More information is found in the original report.)

Furthermore, in the automated image analysis, voids are described with various parameters, and in the subsequent calculation from 2D to 3D distributions, some cavities of a too irregular (non circular) shape are disregarded. This may not be a correct procedure; since many of the compaction pores are of the same size as air voids, they are not likely to get filled with water easily, and thus they probably do provide some protection against frost destruction. Thus they should in fact be included in the calculations. Then, on the other hand, these irregular voids cannot be treated with the mathematics described above, and thus including them in this calculation will cause an error in the calculation of different air void system parameters.

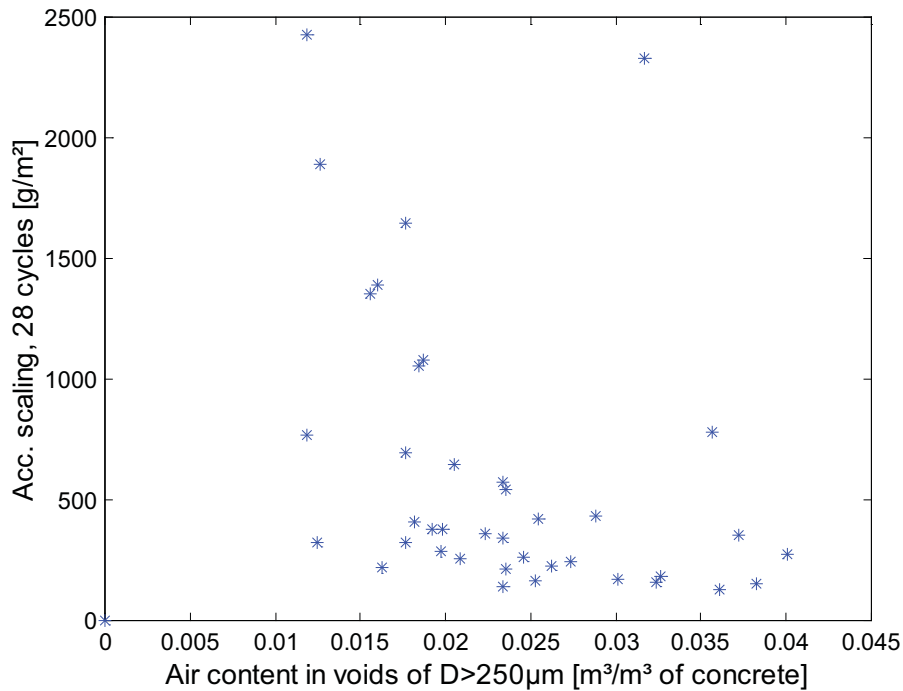

Figure 25: Scaling vs. total air content [m^3/m^3] in air voids of diameter $>250\mu m$. Concrete of w/c 0,40.

6. ALTERNATIVE TECHNIQUE FOR PREDICTING SALT FROST SCALING FROM ONE SINGLE AIR VOID SYSTEM PARAMETER

It should be clear that the demands on a high quality air void system are both that the total air volume must be large enough to provide space for ice formation (whichever way the ice formation process takes place), and that the distances between spheres must not be too large. Together, these two requirements result in an air void system in which the total sum of air void surface areas has some value: Small voids produce a large surface area per unit volume, but if there are too few of these small voids, the total air content will be too low. On the other hand, large voids will produce a volume large enough to allow ice formation without any stresses in the matrix, but then again, if there are too few of these large voids, the flow distance between them may become too large.

From this reasoning, it was hypothesized that for reasonably normal air void systems, the accumulated surface area of all air voids might be useful for assessing the quality of an air void system; Provided that the accumulated surface area is large enough, the total volume of air will be large enough and at the same time the flow distances will be kept short enough. This should hold true at least as long as ordinary air entraining agents are used. Minor shortcomings in flow distance might be counterbalanced by increased air content and vice versa.

In figure 26 the accumulated scaling of all concretes tested in this project are plotted vs. the accumulated surface area of their respective air void systems. The results seem to be fairly well gathered together, with concretes of w/c 0.50 consistently showing larger amounts of scaling (as might be expected). At least, there is a more obvious relation between this parameter and scaling than for any of those relations presented above (air content, specific surface or Powers spacing factor, etc.).

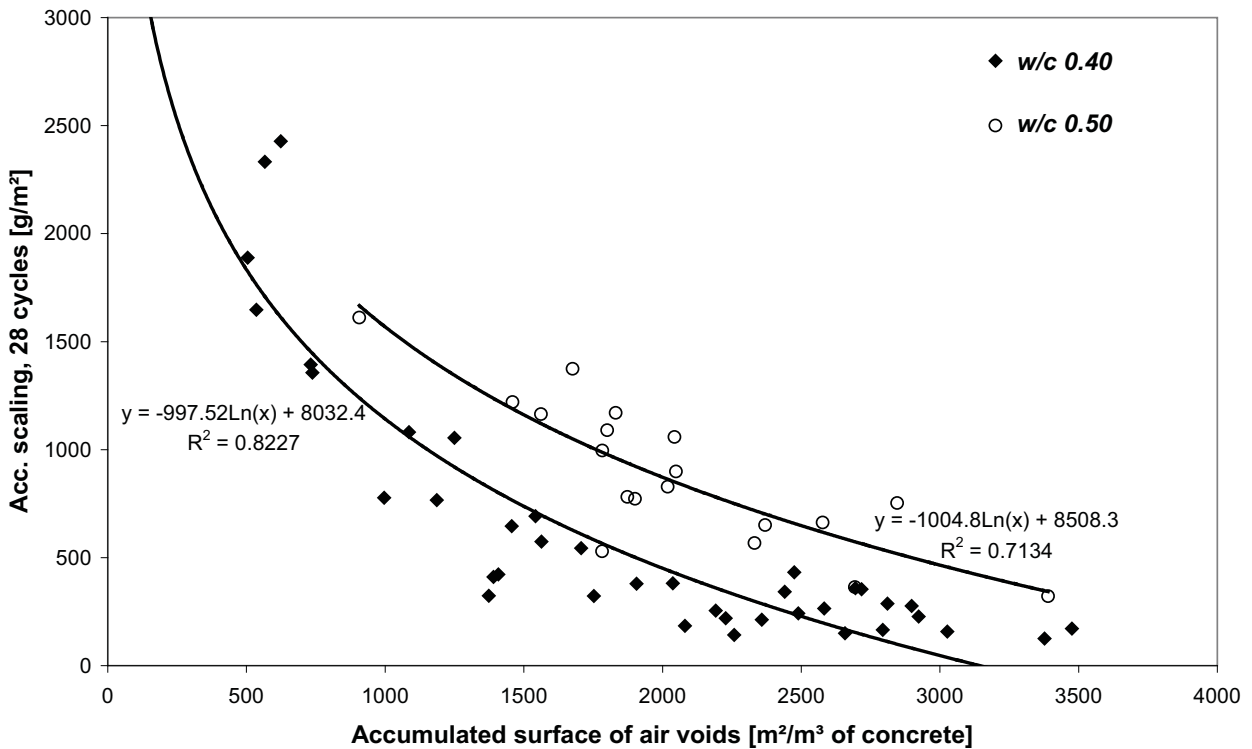
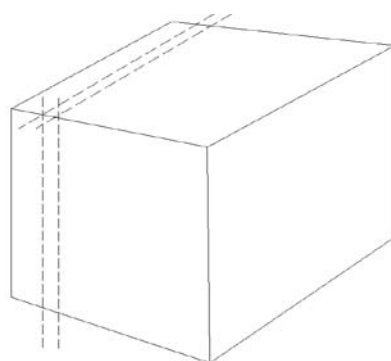

Figure 26: Scalings after 28 cykler plotted vs. the accumulated surface area of the entire air void system. In the calculatin of surface area, it is assumed that all voids are empty (non of them are filled with water).

Lines/equations have been fitted to the plots. As seen (especially for w/c 0.40) the dots actually show more clearly that scaling increases substantially as the total surface area is reduced below some $1500 \text{ m}^2/\text{m}^3$ of concrete than the equation reveals. (A reduction of surface area below this value leads to an increase in scaling, while an increase in surface area has little ability to reduce the scaling.) Of course, the required surface area needs to be calibrated in a full scale test with the appropriate test method (SS137244 etc.)

The logical background as to why this parameter might be useful may be visualized as follows: When ice forms in concrete, destruction may be caused either by hydraulic pressures or by microscopic ice lens growth (or a combination). In either case, there has to be empty space enough to accommodate the excess volume that appears, and also, the flow distance for water must not be too long. It is known that for many brittle, porous materials, there exists a critical thickness below which a thin flake will not be destroyed by frost even if it is frozen in a 100% complete saturation [7,8]. This is believed to be so because the flow distance for water to the surface is short enough. For concrete this critical thickness is in the order of 1 mm. Thus, if a 1 m^3 cube of concrete were sliced into 1 mm thick discs (figure 27), the flow distances would be short enough and the discs would not be destroyed. The drainage area created in such a cube by this slicing is 2000 m^2 (1000 slices with two surfaces), *i.e.* $2000 \text{ m}^2/\text{m}^3$. This drainage area is of the same order of size as indicated in figure 26. Although the geometries are very different, the correct order of size indicates that the proposed evaluation technique may be relevant.

Of course, the remarks made under subheading 5.2 apply also for this way of evaluating the air void system. And, again, there also has to be a minimum requirement on the total air content to accommodate the excess volume created by the ice formation.



Slice in discs $D = D_{crit} = \text{appr } 1 \text{ mm}$

Total surface area of all discs = $2000 \text{ m}^2/\text{m}^3$ concrete

Figure 27: Illustration to the slicing of a concrete cube into thin slices of thickness D_{crit} .

7. CONCLUSIONS

Despite the use of different ways to change the air void system, the size distribution of the air void systems were very similar; More or less only the total number of bubbles increased, and thus the total air content. For a truly meaningful analysis of the relation between air void system parameters and salt frost scaling, it is necessary to produce concretes of radically different air void size distributions.

Using accumulated surface area of all voids in the air void system may be an effective tool for assessing the salt frost resistance of a concrete. The exact need for surface area is probably related to water cement ratio and to volume of paste. And of course, a certain total empty air volume too is required. The surface area required for acceptable salt frost resistance in laboratory tests needs to be determined from scaling tests according to standardized methods.

The methodology for air void system analysis needs to be improved in order to improve its repeatability.

The tool that was the aim of this project may prove successful on a relative scale rather than an absolute scale: In the pre-testing of concrete for a project, the air void system of concrete that is approved for use in the project may be analyzed and then, when the construction work starts, the cast concrete can be analyzed and compared to the concrete that was approved in pre-testing. In this way, changes in the air void structure may be discovered at an early stage, and subsequent problems with insufficient salt frost resistance may be avoided.

A continued analysis of the results in the original report might reveal better assessment techniques than those studied hitherto. An attempt will be made to finance such a study.

8. ACKNOWLEDGMENTS

My sincere thanks are due to professor Göran Fagerlund who initiated this study and who also made it possible through cooperation with SBUF. Dr. Kyösti Tuutti of Skanska acted as project leader (within SBUF), thereby contributing greatly to making the project possible. I am also greatly indebted to Peter Laugesen of Dansk Beton Teknik, Copenhagen, for truly invaluable help on the techniques of preparing samples for image analysis. Mr Bengt Nilsson carried out all

the practical work on the air void system analyses with accuracy and great patience. Thank you all for making this study possible!

9. REFERENCES

1. Lindmark, S: Studier av samband mellan betongs luftporsystem och dess saltfrostbeständighet, Lund University, Lund Institute of Technology, Report TVBM-3089, 2000
2. Underwood, E.E: "Quantitative Stereology", Addison-Wesley Publishing Company, Reading, Massachusetts, 1970
3. Vesikari, E: "Image analysis in determining pore size distributions of concrete", Technical Research Centre of Finland, Report 437, Espoo 1985
4. Lord, G.W, Willis, T.F: "Calculation of Air Bubble Size Distribution from Results of a Rosiwal Traverse of Aerated Concrete", ASTM Bulletin, Oct. 1951, pp 56-61
5. P. Laugesen, personal communication, 1999
6. Fagerlund, G: "Predicting the service life of concrete exposed to frost action througha modeling of water absorption process in the air-pore system", RILEM/NATO Workshop "The modeling of microstruktur and its potential for studying transport properties and durability", St. Rémy-les-Chevreuse, July 10-13, 1994
7. Fagerlund, G: "Significance of critical degrees of saturation at freezing of porous and brittle materials", Report 40, Lund Institute of Technology, Div. Building Technology, 1973
8. Fagerlund, G: "The critical spacing factor", Report TVBM-7058, Lund Institute of Technology, Div Building Materials, 1993