

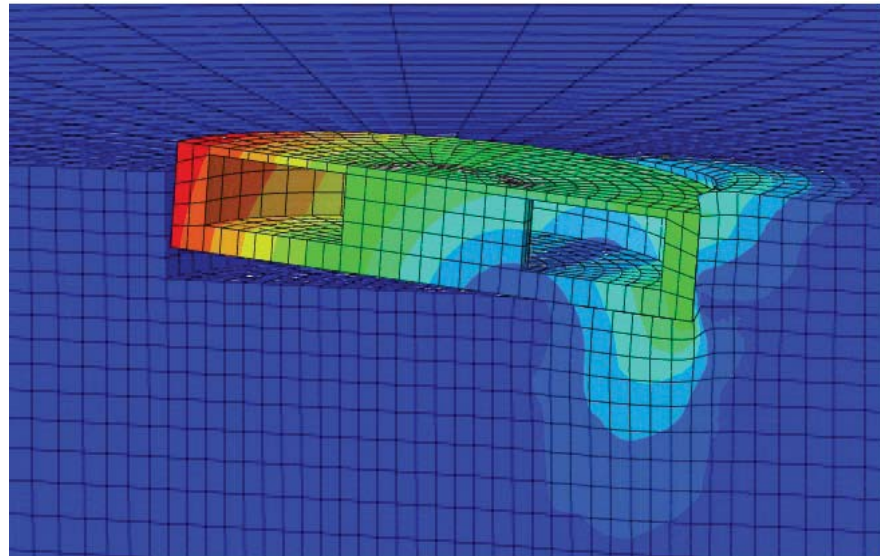

LUND
UNIVERSITY



ONSHORE WINDMILL FOUNDATIONS

Evaluation of new proposals

Wael Mohamed

Structural
Mechanics

Doctoral Thesis

DEPARTMENT OF CONSTRUCTION SCIENCES
DIVISION OF STRUCTURAL MECHANICS

ISRN LUTVDG/TVSM--17/1029--SE (1-192) | ISSN 0281-6679
ISBN 978-91-7753-525-6 (print) | ISBN 978-91-7753-526-3 (pdf)
DOCTORAL THESIS

ONSHORE WINDMILL FOUNDATIONS

Evaluation of new proposals

WAEEL MOHAMED

Copyright © Wael Mohamed 2017.

Printed by V-husets tryckeri LTH, Lund, Sweden, December 2017 (*PI*).

For information, address:

Division of Structural Mechanics,
Faculty of Engineering LTH, Lund University, Box 118, SE-221 00 Lund, Sweden.
Homepage: www.byggmek.lth.se

Acknowledgements

This work was carried out at the Division of Structural Mechanics, Faculty of Engineering at Lund University, Sweden. This kind of work is not something I could have done without the help of others. First of all, I would like to thank my supervisor Prof. Per-Erik Austrell for his valuable support, guidance and encouragement. Without his support the work would not have been possible. Furthermore, I would also like to express my sincere gratitude to prof. Kent Persson, Prof. Per-Johan Gustafsson, and Prof. Ola Dahlblom for always being there helping and supporting me. Great thanks go to my friends and colleagues at the Department of Construction Science Alex, Vedad, Ola, Juan, Peter, Johan, Anders, Daniel, Rikard, and Carlos.

I would like to take the opportunity to thank my beloved parents, my grandfather Abdelrahman Alkhalidi, my brother, my sisters, and my wife for their big love, patience and all understanding during my study.

Lund, December 2017

Wael Mohamed

Abstract

Windmill structures must withstand very high horizontal loading giving an extremely large overturning moment on the foundation. These structures have very low stability loads in comparison to the overturning loads. The traditional way to solve the construction problem uses a shallow foundation with a massive concrete volume or a piled foundation to resist the extreme overturning moment. This work aims towards finding new and reusable cost-effective onshore foundation solutions. The new solutions include a conical raft and rafts with active stabilisation systems. A number of case studies have been done in order to illustrate the behaviour of the new foundation solutions and compare them with the behaviour of the traditional solutions. A comparative study between a proposed raft of conical shape and the traditional raft foundation is done, and the results show that a conical raft can be a good choice if the location of the groundwater is at or near the ground surface. Also, a conical raft requires a smaller diameter than a flat raft to pass the requirements of the geotechnical design. This may decrease the concrete volume used, shorten the construction time, and save money. It can be a good economic and environmental alternative to a flat raft, especially in countries where labour to material cost ratio is low. For soils containing deep soft layers of clay, using a piled raft with deep friction piles is the traditional solution. In this work two solutions using an active stabilisation system, are proposed. They both use movable loads to counteract the overturning moment, using the control system of the rotor hub to move the loads to the best position. The foundation solutions use water and stone material, respectively, to facilitate the counteraction of the overturning moment. It is shown that a raft using an active stabilisation system overcomes the tilting problem giving a tilting lower than a piled raft in many existing soil profiles. Although, using a piled raft gives the lowest magnitude of total settlement. In the case of using water, a cost comparison is done looking at costs for a raft surrounded by a water tank compared to a piled raft with long friction piles. It is shown that the active system decreases the foundation costs compared to traditional piling. As the foundation lifetime is significantly longer than the rest of the structure, the possibility to reuse foundations is also investigated. It has the advantage of speeding up the repowering process, reduce the environmental impact and it could also save money. Reusing foundations when tower and turbine need upgrading can be done both for the new solutions discussed and in some cases also for existing foundations. A study of 60 geotechnical reports for windmill sites in Sweden show that it is possible to increase the load capacity of the foundations, by doing some adjustments. Increasing the stability loads of the windmill structure by using natural materials is a good solution to increase the load capacity of the foundation and make it able to support extra overturning loads. Concerning the environmental impact, reusing the

foundations can save a significant amount of CO₂ compared to the complete dismantling of an existing raft foundation and replacing it with a larger one. Reuse of windmill foundations can also reduce the repowering construction time and make the process less expensive.

Contents

I	Introduction and overview of the work	1
1	Introduction	3
1.1	Onshore windmill foundations.....	3
1.2	Conical footings.....	5
1.3	Reuse of foundations.....	5
1.4	Aim, significance and limitations.....	6
1.5	Overview of dissertation	7
2	Wind loads and overturning moment-2MW turbine	9
3	Geotechnical design of shallow foundations	15
3.1	The required diameter due to soil bearing capacity	16
3.2	The required diameter due to overturning	18
3.3	The required diameter due to sliding	19
3.4	Check for settlement and tilting.....	20
4	Foundation descriptions	21
4.1	Traditional foundation solutions.....	21
4.1.1	Flat circular raft.....	21
4.1.2	Piled raft.....	21
4.2	Conical footing.....	22
4.3	Raft using an active stabilisation system.....	22
4.3.1	Using water as a movable load.....	25
4.3.2	Using wagons filled with soil as a movable load.....	27
5	Soil composition, properties and modelling	33
5.1	Soil properties	36
5.1.1	Port-Said soil properties.....	36
5.1.2	Gothenburg soil properties.....	38
5.1.3	Linköping soil properties.....	38
5.1.4	Torsås soil properties.....	39
5.1.5	Essunga soil properties.....	40
5.2	Soil modelling.....	41
6	FE Analysis of soil-foundation interaction	43
7	Summary of appended papers	47

8	Concluding remarks	53
8.1	Conclusions.....	53
8.2	Proposals for future work.....	54
	Bibliography	57

II Appended publications

Paper A

A comparative study of three onshore wind turbine foundations

W. M. Mohamed and P.E. Austrell

Published in Computer and Geotechnics Journal

Paper B

Optimization of wind turbine foundations for poor soil

W. M. Mohamed and P.E. Austrell

Based on a paper published in the Proceedings of COMPDYN 2015, Crete; Greece; 25 - 27 May 2015

Paper C

A new onshore wind turbine foundation system for poor soil

W. M. Mohamed and P.E. Austrell

Based on a paper published in the Proceedings of EWEA 2015, Paris; France; 17 - 20 November 2015

Paper D

A reusable active foundation solution for onshore wind turbines

W. M. Mohamed, P.E. Austrell and Ola Dahlblom

Submitted for publication in Environmental Geotechnics (under review)

Paper E

A new and reusable foundation solution for onshore windmills

W. M. Mohamed, P.E. Austrell and Ola Dahlblom

Submitted for publication in Computer and Geotechnics (under review)

Paper F

The possibility to reuse onshore windmill foundations from the geotechnical point of view

W. M. Mohamed and P.E. Austrell

Submitted for publication in Acta Geotechnica

Part I

Introduction and overview of the work

1 Introduction

Wind power is one of the most significant clean sources. This fact has encouraged many countries to set a goal for increasing their future wind power. In Sweden, for example, the government declared the intention of generating 25~30 TWh/year by 2020 rather than 7.1 TWh/year achieved in 2012 [1] [2]. In Egypt, still being a developing country, the government has also stated that the Egyptian wind energy share will reach 7% by 2022 instead of 1.2% in 2016 [3]. Building new wind farms and repowering the existing wind power projects will have to be done to meet this goal. Repowering a wind power project currently means the complete dismantling of the windmill structure (turbine, tower and foundation) at an existing wind farm and replacing these units with bigger foundation, taller towers and larger turbines [4].

In Europe, repowering first appeared in Denmark and was followed by Holland and Germany. Under the first wind repowering programme in Denmark, 1,480 turbines producing about 122 MW were dismantled and replaced with 272 new turbines generating 332 MW [5]. Also, in Germany, a wind farm containing 116 wind turbines producing about 56 MW was replaced by a less number of new wind turbines that can generate 183 MW [6]. Many European countries are interested in repowering their existing wind farms. The reason for this is that 76 GW of onshore capacity in Europe will reach the end of its design life between 2020 and 2030 [7].

Windmill structures experience an extremely-high horizontal wind load giving a large overturning moment on the foundation. The windmill structures have relatively low stability loads compared to the overturning loads. The traditional way to solve this problem uses a shallow foundation with a massive concrete volume or a piled foundation to resist the extremely high overturning moment. Typically, raft foundations are 12 to 18 m in diameter, approximately 0.7 to 1 m thick at the edge, 2.5 to 3.5 m thick at the centre, contain 140 to 460 cubic meters of concrete, and 12.5 to 36 tonnes of reinforcing steel [68]. It is well known that cement is the primary ingredient in concrete and the production of cement is responsible for 5~7% of the global carbon dioxide emissions [8] [9]. Therefore, using natural materials to improve the stability of windmills and decrease the required concrete volume is a good idea to minimise CO₂ emissions.

1.1 Onshore windmill foundations

There are many types of onshore windmill foundations. The suitable foundation type can be chosen based on many aspects such as soil properties and turbine loads. In regions with

strong soils, shallow foundations such as raft foundations are used to support windmills. However, in regions with weak soils, deep foundations such as piled rafts and tensionless piers are used to support windmills and transmit the loads to deeper soil layers. Shallow foundations have several advantages when compared to deep foundations, being mainly low cost and less construction time.

Three types of onshore foundation solutions are discussed here. The first and the traditional one on regions with strong soils is a raft foundation shown in Figure 1-a. A raft foundation is considered as a shallow foundation. This solution mainly uses the weight of the foundation, the backfill soil weight, bearing pressure on the foundation base, and the friction between the foundation and the soil to resist the vertical and overturning loads [10]. The second solution is Patrik & Henderson tensionless pier which is shown in Figure 1-b. It primarily resists the horizontal forces and the overturning moment by using the horizontal resistance of the surrounding soil. This solution resists the vertical load by using the bearing on the pier base and the friction between the soil and the pier [10]. The third solution is a piled foundation which is shown in Figure 1-c. A piled raft is also considered as a deep foundation solution. This solution resists the vertical and overturning loads by using the bearing pressure on the raft base, the end bearing of the piles, the friction between the raft and the soil, and the friction between the soil and the piles.

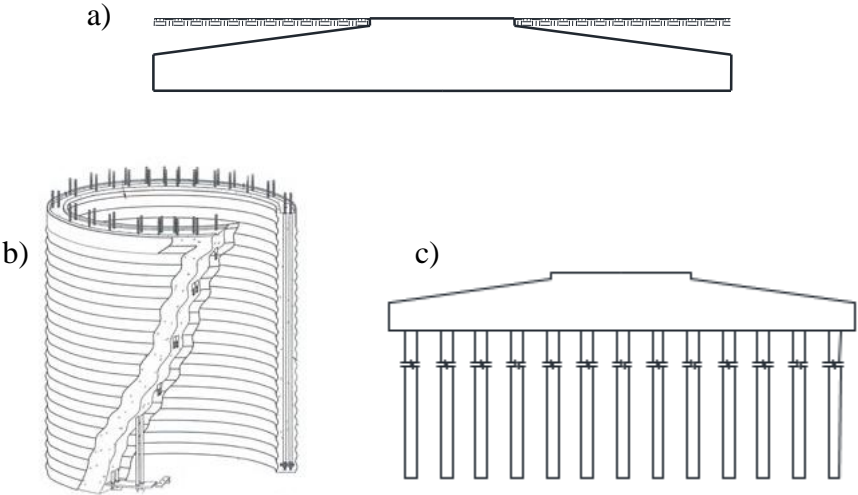

Figure 1 Onshore windmill foundations a) a raft foundation, b) a P&H tensionless pier [59], and c) a piled raft.

The foundation budget range is influenced by many factors such as the soil properties, the foundation type, and the foundation dimensions. According to several studies, shallow onshore foundations on a good soil make up about 3%-7% of the total costs [34] [35] [36].

On the other hand, it is expected that if a piled raft is required the percentages will increase dramatically to about 15%~28% [37].

1.2 Conical footings

Conical footings are proposed in some designs considered in this work, see Figure 2. New onshore windmill foundation solutions are presented using a conical raft with and without an active stabilisation system. Conical footings have to the knowledge of the author not yet been used as a foundation supporting windmills. However, they have been used as a footing for different kinds of buildings in many countries [12]. The concept of using conical footings was developed to improve the load capacity and also the geotechnical behaviour of foundations. Many researchers have studied the load capacity and the geotechnical behaviour of such footings. A number of these studies are discussed below.

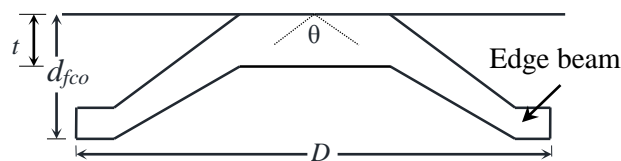

Figure 2 A conical footing.

Many scholars hold a view that conical footings are capable of supporting higher vertical loads compared to flat footings. Abdel-Rahman [12] investigated the geotechnical behaviour of conical footings experimentally and compared with flat footings. The core results were; the ultimate load capacity of conical foundations are significantly higher than the traditional flat counterparts with the same plane dimensions. Also, the conical foundations have better settlement performance than the conventional flat ones [12]. A conical footing was considered in another study done by Huat and Mohammed [13]. The results showed that the load capacity of a conical footing is higher than the load capacity of a flat footing for a similar plane dimension. Also, adding an edge beam at the bottom of the conical footings increases the load capacity of the footing [13]. The failure mechanism of conical and flat footings was obtained by conducting laboratory model tests [14]. The results also showed that using a conical footing can decrease the shear failure probability compared to a flat footing [14].

1.3 Reuse of foundations

The financial feasibility is the most significant constraint on a construction project. A cost analysis of alternative designs and materials has to be done in order to make sure that the project is reasonably priced. In many cases, foundations make up a high percentage of the

total cost. The reuse of foundations has been considered for urban project sites. One was started in 2003 to inspire geotechnical engineers to consider reuse of foundations [15]. Many researchers believe that there are economic and environmental advantages of reusing existing foundations. However, only limited investigations have been carried out to evaluate the reuse of foundations [16] [17] [18].

In another project, it was estimated that almost 4,000 tonnes of CO₂ were saved by reusing the existing piles for high-rise building foundation in Japan according to Watanabe et al. [19]. Also according to Laefer and Manke [20], the savings of reusing a deep foundation for a building range from 4% to 65% depending upon how much of the existing structure being retained.

Currently, the onshore windmill is the cheapest power generation technology in Europe [57]. Making land-based windmill foundations in this study an important matter. The lifespan of a modern wind turbine is 20-25 years [11]. However, 100 years or more can be achieved for high-quality concrete foundations. Once the turbines exceed their design-life, the common option is to have the whole windmill including the foundation removed entirely. However, there are economic and environmental benefits of changing the out-of-date wind turbine with a new and better one and reuse the foundation. The big difference in lifetime shows a significant potential for reusable foundation solutions to allow wind power projects to be updated with taller and larger units in order to increase the energy production at a given site.

Using taller towers and larger turbines will add extra overturning loads to the windmill structure. These loads will be transmitted to the foundation and the subsoil, producing increased stresses and deformation therein. Therefore, some cost-efficient adjustments should be done to make the foundation and the subsoil able to handle the extra overturning loads. This work presents cost-efficient solutions to reuse existing raft foundations. Also, it presents new foundation solutions which are able to increase their load capacity by doing a low-cost adjustment.

1.4 Aim, significance and limitations

This work proposes new and reusable foundation solutions able to reduce the failure probability of onshore windmills, speed up the repowering construction time, and reduce the environmental impact. Also, this work presents a solution to improve the load capacity of an existing raft foundation. In addition, comparative studies of the new foundation solutions and the traditional foundation solutions have been performed numerically using finite element simulations.

The foundation solutions which use active stabilisation systems and rafts with conical shapes have never been used as foundations supporting onshore wind turbines. This work is intended to encourage engineers to consider new foundation solutions and achieve the most stable, safe, and cost-efficient option in locations with weak soil conditions. Concerning the limitations, this work will not deal with offshore foundation solution, dynamics, and fatigue.

The main aims of this study are:

- 1) to make a comparison between the new solutions and the traditional foundation solutions considering different existing soil conditions,
- 2) to show the load capacity of the new foundation solutions,
- 3) to present the main risks of using an active foundation system and how to minimise these risks, and
- 4) to present a number of cost-efficient solutions which give the existing windmill foundations the ability to be reusable.

1.5 Overview of dissertation

This thesis consists of two parts. The first being an introduction and summary of the work and the second consists of the appended papers. In the first part, a summary and overview of the work are presented. In addition to the introduction in this chapter, the dissertation summary is arranged in seven more chapters. The second chapter shows the variation of the maximum overturning moment on the foundation with wind speed. The third chapter reviews the geotechnical design of shallow foundations and how to calculate the required diameter of the foundations. The fourth chapter contains the foundation description. The fifth chapter introduces the studied soil cases, soil properties, and geotechnical material models. The sixth chapter discusses the FE models. The seventh chapter shows a summary of the appended papers. The eighth chapter gives a summary, conclusion and a proposal for future work.

Part II consists of six appended papers. Paper A is an investigation concerning the geotechnical behaviour of a conical raft. Also, a geotechnical comparison between the traditional flat raft and the conical raft is done. In Paper B, the geotechnical behaviour of a circular raft surrounded by a water tank is investigated using Gothenburg soil properties, and a cost comparison between this new foundation solution and a piled raft is made according to Swedish construction costs. In Paper C, geotechnical and economic comparisons between a circular raft surrounded by a water tank are done using a layered

soil near Port-Said city. In Paper D, the load capacity of a conical footing with an active system and a traditional circular raft is investigated using a soil near Linköping in Sweden. Also, it shows the adjustment that makes the conical footing with an active system able to resist larger overturning loads. In Paper E, a new and reusable foundation solution using a cellular raft with an active stabilisation system is proposed. Also, a comparative study of the new foundation and a traditional raft is performed. In Paper F, the work focuses on finding a cost-efficient solution to reuse existing raft foundations. The effects of increasing the stability loads on the load capacity of raft foundations are investigated. New ways are used to increase the stability load of a windmill such as filling the lower part of the tower with soil and using heavier backfill soil.

2 Wind Loads and overturning moment-2MW turbine

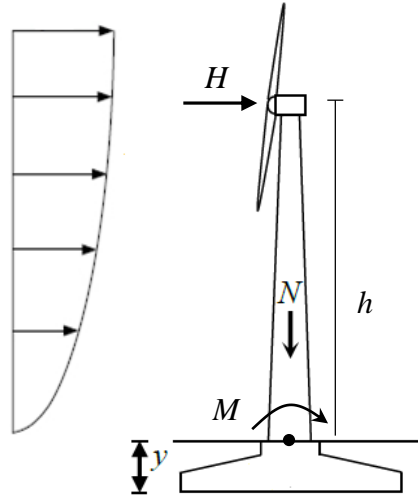

Figure 3 Wind loads on a windmill structure.

It is well known that the wind loads depend on the wind speed which in turn depends on shape and height of the structure and the topography of the surroundings. In this chapter, an onshore wind turbine with a rated power of 2 MW is considered to show the effect of the wind speed on the overturning moment on the foundation. The wind loads on a windmill structure are shown in Figure 3. Load conditions corresponding to a Vestas V90-2MW wind turbine with 80 m tower height at the west coast of Sweden [65] are presented in Table 1.

Table 1 Tower base loads of a Vestas V90-2MW wind turbine at the west coast of Sweden [65].

Type of limit state	Loads			
	N (MN)	H (MN)	M (MNm)	M_z (MNm)
SLS	3.51	0.482	35.108	0.303
ULS	3.51	0.797	63.825	1.64

Two sets of loads are shown in the table; serviceability limit state (SLS) and ultimate limit state (ULS). The purpose of the serviceability limit state (SLS) requirements is to ensure that a construction is not affected by large settlements, tilting, cracks in concrete, etc [61]. These performance criteria must remain within pre-specified acceptable levels. The serviceability limit state (SLS) loads are used in the FE analysis in this study to calculate the settlement and the tilting of the foundations. The main purpose of the ultimate limit state (ULS) requirements is to ensure that the structure must not collapse when subjected to the highest load for which it was designed. The foundation needs to be verified in terms of bearing capacity, sliding resistance, and overturning resistance in the ultimate limit state

(ULS). Each set contains a centric vertical load N from the tower, blades, and nacelle being the same in both cases, a horizontal load H , a torsional moment M_z , and a bending moment M . The characteristics of a Vestas V90-2MW wind turbine [62] are shown in Table 2.

Table 2 The characteristics of Vestas V90 wind turbine [62]

Rated power	2 (MW)
Hub height	80 (m)
Rotor diameter	90 (m)
Range of operation	4-25 (m/s)
Rotating speed	9.3-17(rpm)
Rated wind speed	12 (m/s)

In this section, formulas are presented for calculation of the maximum overturning moment on the foundation due to the wind speed [63]. Most of the formulas presented in this chapter are summarised from a work of Ishii and Ishihara [63]. The accuracy of these formulas have been verified by field tests and the formulas show good agreement with measured data [63]. A comparison between the calculated overturning moment and the SLS data in Table 1 will be done to check the accuracy of these formulas.

The maximum overturning moment M on the foundation in operating conditions is

$$M = \frac{1}{2} \rho_a v_h^2 \pi R_r^2 h C_{MD} G_D \quad (1)$$

where ρ_a is the air density, v_h is the wind speed at the hub height, R_r is the rotor radius, h is the hub height, C_{MD} is the tower base moment coefficient, and G_D is the gust factor.

The tower base moment coefficient C_{MD} is expressed as follows

$$C_{MD} = \varepsilon_T C_{DT} \left(\frac{1}{3+3\alpha} + \frac{1}{6} \right) + \varepsilon_N C_{DN} + C_T \quad (2)$$

where C_{DT} is the average drag coefficient of the tower, C_{DN} is the average drag coefficient of the nacelle, C_T is the thrust coefficient of the rotor [66], ε_T is the ratio of the projected tower area to the rotor area, ε_N is the ratio of the projected nacelle area to the rotor area, and α is the power law exponent of the normal wind profile. C_{DN} , C_{DT} and α were assumed 1.2, 0.6 and 0.2 respectively in the calculation. At the maximum power output. C_T is taken from the turbine documents [67].

The gust factor G_D [63] is expressed as follows

$$G_D = 1 + 2I_{ref} \left(0.75 + \frac{5.6}{v_h} \right) g_D \sqrt{K} \sqrt{1 + R_D} \quad (3)$$

where I_{ref} is the expected value of the turbulence intensity when the mean wind speed at the hub height is 15 m/s, v_h is the mean wind speed at the hub height, g_D is the peak factor, K

is the size reduction factor, R_D is the ratio of the resonance response variance to the background response variance. In the calculation, the turbulence intensity was assumed to be equal to 0.1 (onshore).

Formulas for calculating g_D , R_D and K [63] were proposed in Table 3. Where v_h is the wind speed at hub height (m/s), v_r is the rated wind speed being the lowest wind speed for maximum power output (m/s), v_{in} is the cut-in wind speed (here 4 m/s), and v_{out} is the cut-out wind speed (here 25 m/s).

Table 3 Simplified formulas for g_D , R_D and K [69]

	$v_h < v_r$	$v_h > v_r$
g_D	$-0.3 \sin\left(\pi \frac{v_h - v_r}{v_{out} - v_r}\right) + 3$	$\sin\left(\frac{7\pi}{8} \left(\frac{v_h - v_r}{v_{out} - v_r}\right)\right) + 3$
K	$0.15 \sin\left(\pi \frac{v_h - v_r}{v_{in} - v_r}\right) + 0.15$	$0.45 \frac{v_h - v_r}{v_{out} - v_r} + 0.15$
R_D	0.2	$2.6 \frac{v_h - v_r}{v_{out} - v_r} + 0.2$

However, in the case of the wind speed being larger than 25 m/s, the maximum overturning moment on the foundation [64] is calculated as

$$M = \int_0^h \frac{1}{2} \rho_a v^2 C_f K_d K_z G_D D(z) z dz \quad (4)$$

where C_f is the force coefficient, K_d is the directionality factor, K_z is the velocity pressure exponent depending on the site relative height to the ground z , G_D is the gust factor, and $D(z)$ is the diameter of the tower.

As shown in Table 2, the operation wind speed range for many types of wind turbines is from 4 to 25 m/s. Therefore, the maximum overturning moment on the foundation under operating conditions is calculated for 11 different mean wind speeds, from 5 m/s to 25 m/s with 2 m/s interval. Also, in the case of the wind turbine is shut down (the wind speed is larger than 25 m/s), the maximum overturning moment on the foundation is calculated for 17 different mean wind speeds, from 27 m/s to 59 m/s with 2 m/s interval. Figure 4 and Figure 5 show the variation of the maximum overturning moment on the foundation depending on the wind speed at hub height.

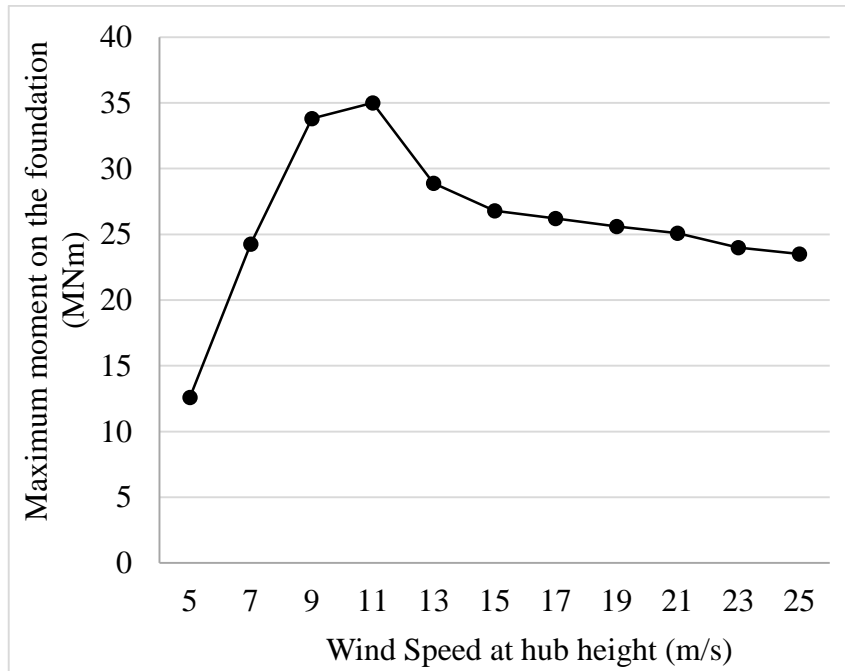

Figure 4 Variation of the maximum overturning moment on the foundation with wind speed at hub height in operating conditions.

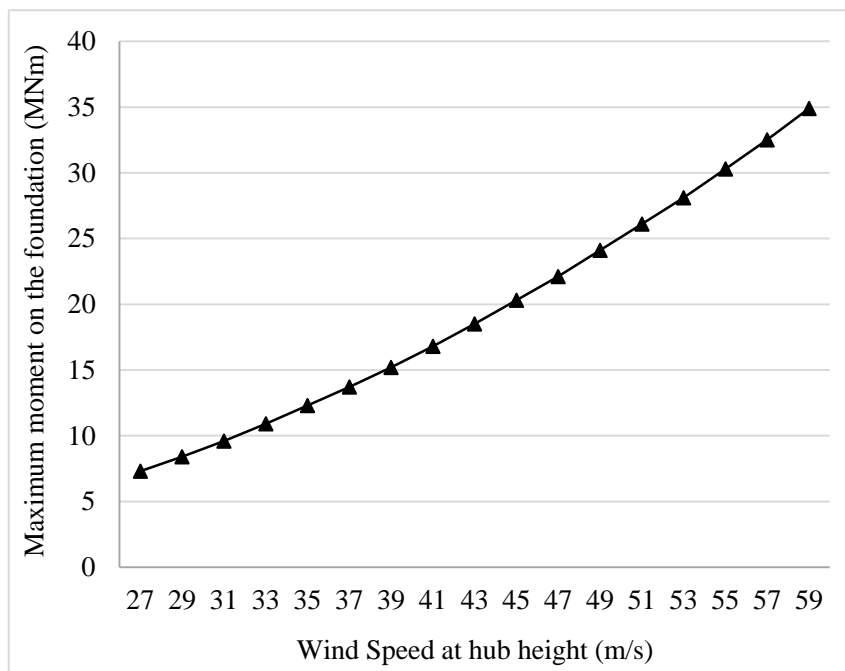

Figure 5 Variation of the maximum overturning moment on the foundation with wind speed at hub height in the case of wind speed is larger than 25 m/s.

In operating conditions, the decrease in the value of the overturning moment happens because of to the pitch control. It makes the blade's surface area, subjected to the wind, becomes smaller although still the power out is at the maximum level for these high wind speeds. Comparing Figure 4 with the SLS data in Table 1 shows that there is a good resemblance between the computed results from the analytical calculations and the SLS data

for the overturning. If the wind turbine is shut down, wind speed equal to 59 m/s is required to reach the maximum overturning moment on the foundation in the operating conditions.

3 Geotechnical design of shallow foundations

The design procedure for any foundation involves four parts. The first consists of determining the applied loads on the foundation. The second involves providing all needed data of the soil properties. The third being a geotechnical design, and the final part involves a structural design [23].

Usually, the turbine specific documents contain information about the loads on the foundation, the foundation rotational stiffness requirements, the natural frequency of the system, fatigue loads, and the maximum tilting of the foundation. The soil investigation consists of laboratory testing of soil samples and also in-situ testing to provide all the ground properties and the groundwater level. The geotechnical design considers many phases such as determination of the foundation dimensions and the foundation weight to minimise the failure probability of the foundation considering soil bearing capacity, sliding, and overturning. A real overturning failure of a shallow windmill foundation is shown in Figure 6.



Figure 6 An overturning failure of a windmill [60].

The structural design considers the determination of the reinforcing steel, the diameter of the anchor bolts, and the concrete strength. In this work, the geotechnical design, the calculation of the foundation dimensions is done analytically using some equations. However, checking the settlement and tilting of the foundation need special geotechnical computer programs which incorporate nonlinear soil models. Hence, in this study, the required diameter of the foundation due to soil bearing capacity and overturning aspects is calculated analytically first. Then, FE analyses are used to calculate the settlement, tilting and load capacity of the foundations. The equations used to derive the required diameter of the windmill foundations are discussed in the following sections.

3.1 The required diameter due to soil bearing capacity

This section deals with equations for calculation of the required diameter of the foundations in terms of soil bearing capacity. The loads from the wind and the weight of a windmill structure, as shown in Figure 7-a, are transferred to the foundation base and combined into resultant horizontal and vertical forces (H and V) at the interface between the foundation and the soil, as shown in Figure 7-b [23]. At the interface between the ground and the foundation, soil cannot carry any tension stresses. Therefore, the contact area between the foundation and the soil is expected to be decreased as the overturning moment increases. In this case, the area which is subjected to a compressive stress is called the effective foundation area. In the case of a circular raft, the effective area is the elliptic area as shown in Figure 7-c. The effective area can be expressed as an equivalent rectangular area (l_{eff} , b_{eff}) that originate from the elliptical area.

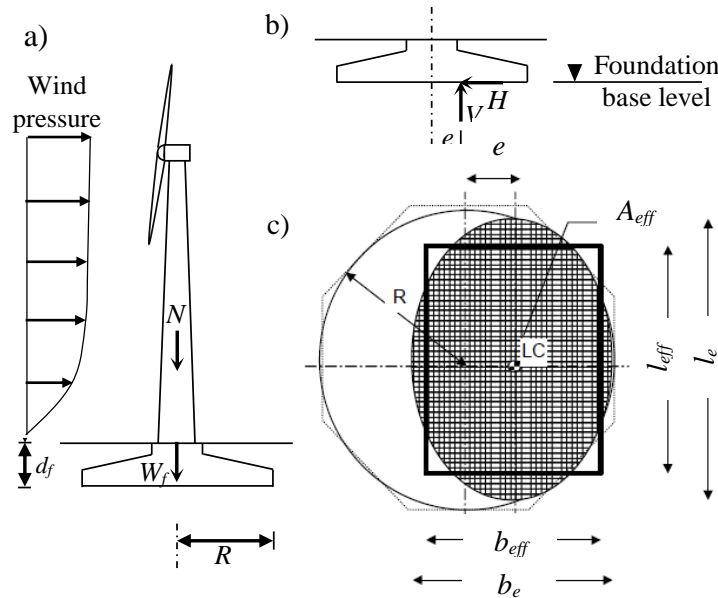

Figure 7 a) Windmill loads, b) reaction forces from the soil, and c) the effective area for a circular foundation [23].

The maximum imposed stresses on the soil from the foundation should be less than the allowable bearing capacity of the soil to avoid shear failure. Therefore, the required diameter of a foundation should be calculated by putting the maximum compressive stress under the foundation equal to the allowable bearing capacity [24].

The total bending moment M_t and the sum of the vertical loads V can be calculated from

$$M_t = M + H(d_f) \quad (5)$$

$$V = N + W_f + W_s - F \quad (6)$$

where M is the bending moment at the tower base, H is the horizontal load at the tower base, d_f is the foundation base depth as shown in Figure 7-a, N is the vertical load at the tower base, W_f is the weight of the foundation, W_s is the weight of the backfill soil, F is the uplift force from the groundwater.

The maximum compressive stress under the foundation is

$$\sigma = \frac{V}{b_{eff}l_{eff}} + \frac{6M_t}{b_{eff}l_{eff}^2} \quad (7)$$

where b_{eff} is the effective width of the footing, and l_{eff} is the effective length of the footing [25]. The effective area for a circular foundation subjected to a high overturning moment [23] can be calculated from

$$A_{eff} = 2 \left[R^2 \cos^{-1} \left(\frac{e}{R} \right) - e \sqrt{R^2 - e^2} \right] \quad (8)$$

where R is the raft radius, and e is the eccentricity. The eccentricity e shown in Figure 7-b can be calculated from

$$e = M_t / V \quad (9)$$

The equivalent rectangular dimensions [23] can be calculated from

$$l_{eff} = \sqrt{A_{eff} \frac{R \sqrt{1 - \left(\frac{R-e}{R} \right)^2}}{(R-e)}} \quad (10)$$

$$b_{eff} = \frac{l_{eff}}{R \sqrt{1 - \left(\frac{R-e}{R} \right)^2}} (R - e) \quad (11)$$

As mentioned, the required diameters of the foundations should be calculated by putting the maximum compressive stress under the foundation equal to the allowable bearing capacity. The allowable bearing capacity q_{all} is obtained by dividing the theoretical maximum pressure that can be supported without causing shear failure, by a factor of safety f_s [26]. This factor ranges from 2 to 3 [27]. Here, the factor of safety is assumed to be 2.26 [28].

There are two ways of calculating q_{all} depending on ground conditions. For drained conditions Meyerhof's equation [29] [30]

$$q_{all} = \frac{cN_c\xi_c + qN_q\xi_q + 0.5\gamma' b_{eff}N_\gamma\xi_\gamma}{f_s} \quad (12)$$

is used where q_{all} is the allowable bearing capacity of the soil (kPa), c is the cohesion (kPa), q is the surrounding stress at the foundation level (kPa), γ' is the effective bulk density of the soil (kN/m³), N_c , N_q , N_γ are the bearing capacity factors depending on the friction angle, and ξ_c , ξ_q , ξ_γ are correction factors. The surrounding stress q at the foundation level is

obtained by multiplying the effective bulk density of the soil γ' by the foundation base depth d_f .

In the case of undrained soil conditions, the allowable bearing capacity q_{all} [31] is

$$q_{all} = \frac{c_u N_c s_c d_c + q}{f_s} \quad (13)$$

where c_u is the undrained cohesion, N_c is the bearing capacity factor in the case of zero friction angle, s_c is a shape factor, and d_c is a depth factor. For flat shapes, the value of the bearing capacity factor N_c in the case of zero friction angle is 5.14. In this study, the same value is assumed for the conical shape. Note that Eq.(12) and Eq.(13) are valid if the eccentricity is smaller than $0.3D$ ($D=2R$). Now the required diameter can be obtained by putting the maximum compressive stress from Eq.(7) equal the allowable bearing capacity (Eq.(12) or (13)) giving

$$q_{all} - \sigma = 0 \quad (14)$$

The diameter is iteratively found from the equation, i.e., by assuming a diameter and iterate until the residual of Eq.(14) is small enough.

3.2 The required diameter due to overturning

This section deals with equations used to calculate the required foundation diameter due to overturning. Since windmill foundations are subjected to extremely high overturning loads, the resistance against overturning must be checked [32]. In order to prevent overturning, the loads from the wind must be balanced by reaction forces from the ground acting on the base of the foundation as shown in Figure 8.

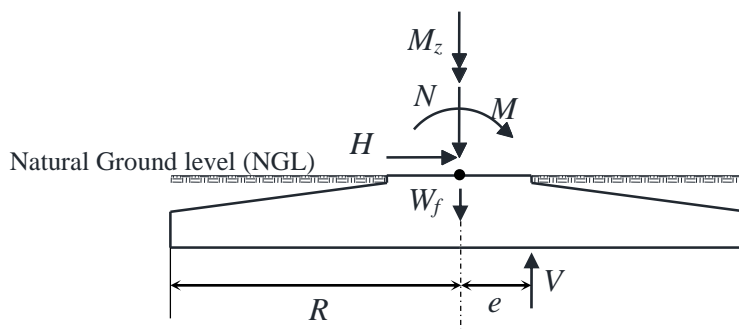

Figure 8 Resistance against overturning.

The residual force from the ground V is acting with an eccentricity e due to the overturning moment. The limiting case occurs theoretically if the eccentricity e is equal to the raft radius R giving the stability moment M_s as

$$M_s = V \cdot R \quad (15)$$

One way to prevent overturning is according to Morgan and Ntambakwa [28] to define a factor of safety against overturning $f_s \geq 1.5$ with respect to the stability moment M_s . In this case, the factor of safety against overturning is

$$f_s = M_s / M_t \quad (16)$$

Another suggestion is given by Szerzo [25] focusing on the eccentricity instead. The eccentricity should fulfil

$$e = M_t / V \quad \left\{ \begin{array}{ll} \leq 0.25R & \text{for serviceability limit state} \\ \leq 0.58R & \text{for ultimate limit state} \end{array} \right. \quad (17)$$

where R is the raft radius, V is the sum of the vertical loads, and M_t is the total bending moment [25]. According to the overturning aspect, the required diameters of the foundations are calculated by putting the factor of safety f_s equal to 1.5 in Eq.(16), and the eccentricity equal to $0.58R$ in Eq.(17).

The diameter is iteratively calculated from the equation, i.e., by assuming a diameter and iterate until the residual of Eq.(16) and Eq.(17) is small enough. The required diameter of the foundation is the largest value of the diameter found from Eq.(16) and Eq.(17).

3.3 The required diameter due to sliding

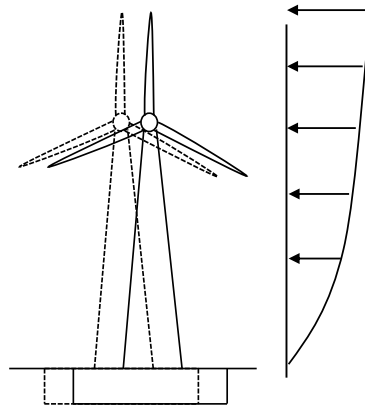

Figure 9 Sliding failure of a windmill.

Windmills are subjected to high horizontal loads from the wind. A sliding failure can be caused by these horizontal loads as shown in Figure 9 and also by twisting due to spatially uneven wind conditions. According to DNV Risø and Hansen [23] [33], the following conditions should be fulfilled to avoid sliding.

$$\frac{A_{eff} c + V \tan \phi}{2M_z / l_{eff} + \sqrt{H^2 + (2M_z / l_{eff})^2}} > 1 \quad (18)$$

$$\frac{2M_z/l_{eff} + \sqrt{H^2 + (2M_z/l_{eff})^2}}{v} < 0.4 \quad (19)$$

Where M_z is a twisting moment, c is the cohesion of the soil, and \emptyset is the friction angle of the soil.

The diameter is calculated by assuming a diameter and iterate until the residual of Eq.(18) and Eq.(19) is small enough. The required diameters of the foundations are the largest value of the diameter from the mentioned equations.

3.4 Check for settlement and tilting

Tilting is considered a serious problem for shallow foundations subjected to large overturning moments. In this work, the FE program -Abaqus- is used to calculate the settlement and the tilting of the foundations. The allowable value depends on the soil type and the foundation type. The maximum settlement and tilting for the foundations should not exceed the values mentioned in the turbine specific documents.

4 Foundation descriptions

The considered new foundation solutions in this work are a conical raft, and rafts using an active stabilisation system. These solutions are compared to traditional foundation solutions in this work. The traditional foundation solutions are a flat circular raft and a piled raft. In the following sections, these foundation systems are shortly described.

4.1 Traditional foundation solutions

4.1.1 Flat circular raft

A flat reinforced concrete raft is the most common foundation system for onshore windmills because it is suitable for many soil types. This solution is considered as a gravity foundation. It is mainly the foundation weight and bearing pressure on the foundation base that are utilized to resist the vertical loads and the overturning moment. Concerning the horizontal loads, they are resisted by the friction between the foundation and the soil. As mentioned, raft foundations are 12 to 18 m in diameter, approximately 0.7 to 1 m thick at the edge, 2.5 to 3.5 m thick at the centre, contain 140 to 460 cubic meters of concrete, and 12.5 to 36 tonnes of reinforcing steel [68]. Details of the geometry and dimensions of a flat circular raft are shown in Figure 10.

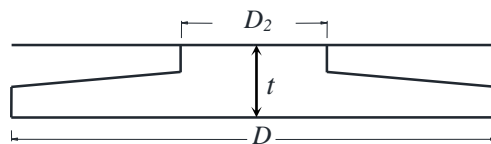

Figure 10 The geometry of a traditional circular raft.

4.1.2 Piled raft

A piled raft is a foundation having piles to stabilise the foundation. The raft and the piles are designed to cooperate to ensure that the settlement does not exceed the allowable settlement value. The piled raft provides excellent performance for settlement and tilting. However, this comes at a high cost, both financially and environmentally, and it needs longer construction time. In this study, friction piles are used for the comparison with other solutions. The geometry of the piled raft is shown in Figure 11.

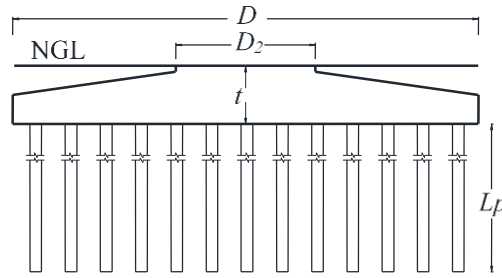

Figure 11 Piled raft geometry.

4.2 Conical footing

According to several studies, the load capacity of conical footings is higher than the flat footings. Also, the conical footings are economical in terms of material volume need compared to the conventional flat footings. However, a conical footing has never been used as a foundation system for onshore wind turbines to the knowledge of the author. It uses the gravity foundation method to resist the extremely high overturning moment. The idea of using a conical shape involves increasing the stability loads due to the weight of the soil placed over the footing and also by increasing the contact area between the footing and the ground. Figure 12 shows the geometry and dimensions of the proposed conical raft being the subject of Paper A.

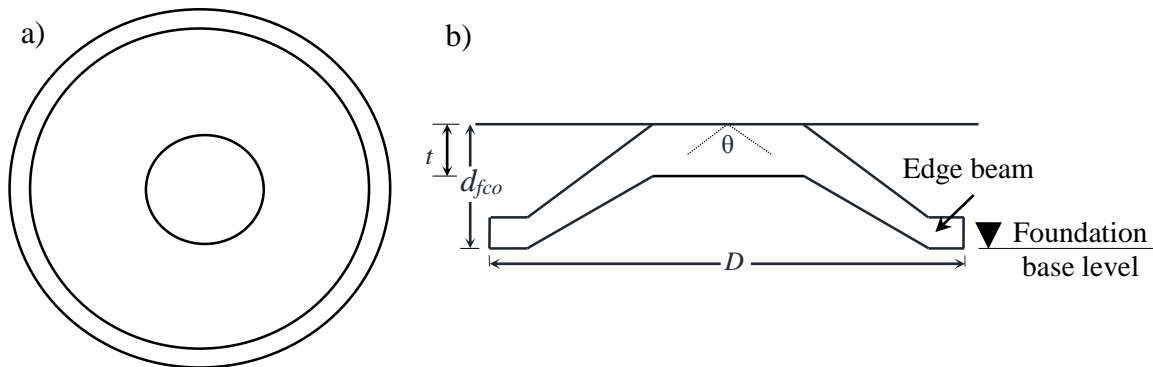

Figure 12 A conical raft a) plan view, and b) cross section.

4.3 Raft using an active stabilisation system

The basic motivation for active stabilisation systems is to find a cost-efficient solution on poor soils. The concept of an active system is a novel idea using a movable weight to stabilise against the overturning moment. Many possible solutions are proposed and discussed in this thesis. The geometries of these solutions are shown in Figure 13. There are two options to get a big resisting moment from a movable load; the first is to use a heavy material as a movable load and the second is to use long beams connecting the raft with the active system.

The main advantage of the active stabilisation systems is that they give the ability for foundations to be reusable and able to support taller towers and larger turbines by doing some cost-efficient adjustments. This study will show the required adjustments in the new solutions to support taller and larger units.

A number of the new solutions resist the overturning loads by the foundation weight, the backfill soil weight and a movable load as shown in Figure 13a and Figure 13b. The design according to Figure 13a is evaluated in Paper B and C. The other solutions use the foundation weight and a movable weight to resist the overturning loads as shown in Figure 13c and Figure 13d. In the case of these two cellular rafts, there is no backfill soil over the foundation. The designs according to Figure 13c and Figure 13d are evaluated in Paper D and E.

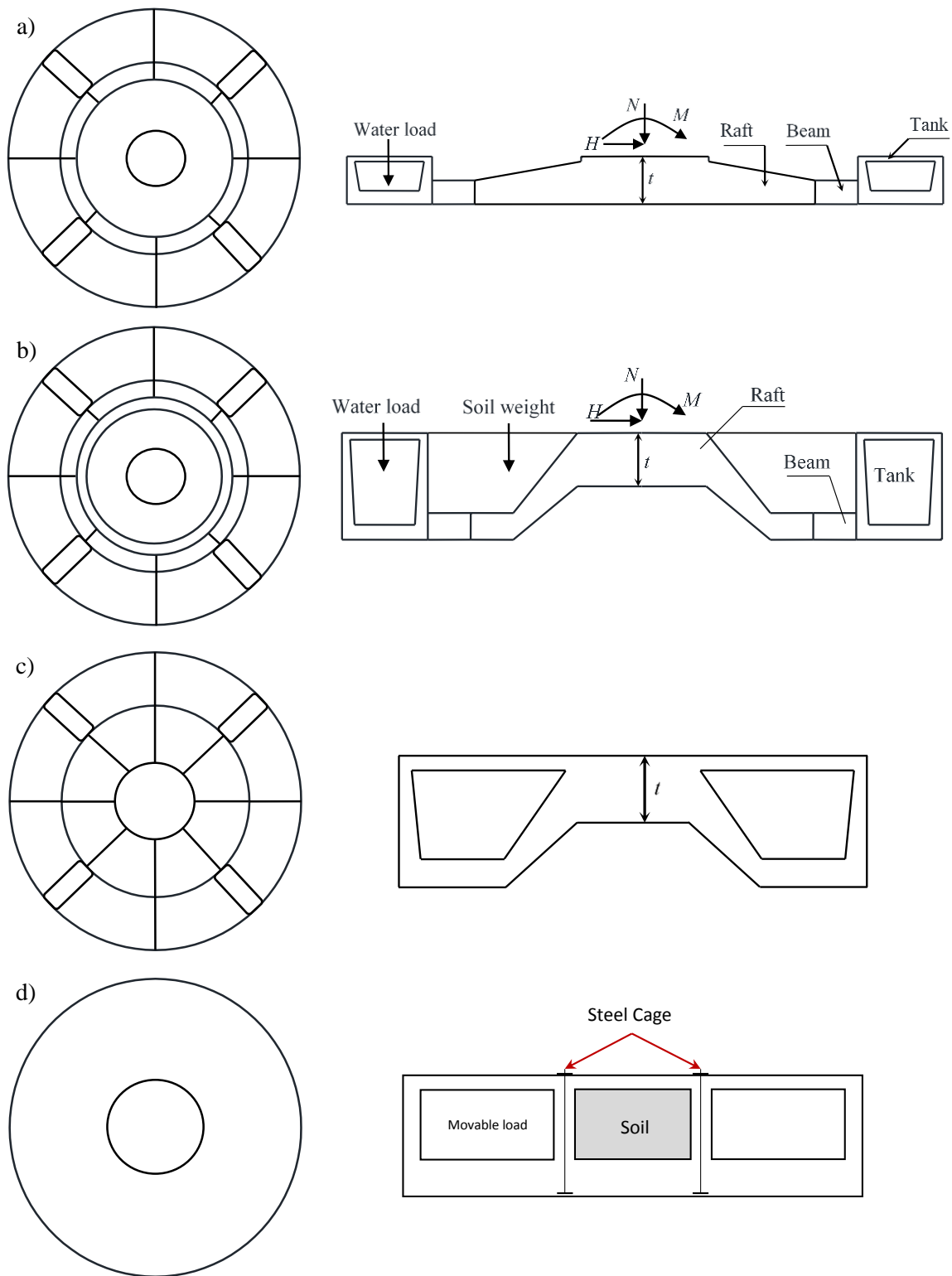

Figure 13 The plan view and the cross-section of a) a flat circular raft surrounded by an active system, b) a conical raft surrounded by an active system, c) a conical cellular raft with an active system, and d) a flat cellular raft with an active system.

In the design of the new foundation solution, it is recommended that the required diameter calculation does not depend on the stabilising moment from the active system. The reason of that is to prevent the failure if the waggons accidentally are in the wrong position.

Two active stabilisation systems are used in this work. One system uses water as a movable load, and the other uses waggons filled with soil or rock. In this section, descriptions of the considered active systems are given. Also, the required adjustment that should be done to make the foundation able to support larger and taller units will be specified.

4.3.1 Using water as a movable load

An active system with water is discussed in Paper B, C and D for actual soils from Gothenburg, Port-Said, and Linköping respectively. A brief discussion of the active systems is given here to show the idea and also discuss costs. The water movement system depends on a number of electric water pumps and pipes with electric valves. This number depends on the water volume and the movement time required. In general, water movement depends on change in the wind direction. The control system for the water movement system uses data from the wind direction and wind speed sensors being used in the yaw system of the wind turbines. In the appended papers, two versions of the active system are proposed.

In the first version (Paper B and C), the water tank is divided into four compartments, as shown in Figure 14, where only one or two compartments will contain water. The disadvantages of the first version are that it is expensive, and the stability moment is not constant in all the load cases. Also, the water cannot be moved directly from a compartment on one side of the foundation to a compartment on the opposite side without moving through the nearest compartment first. Therefore, the active system is improved in Paper D to be cheaper to build and to make the foundation having a better geotechnical behaviour (the stability moment is constant in all the load cases).

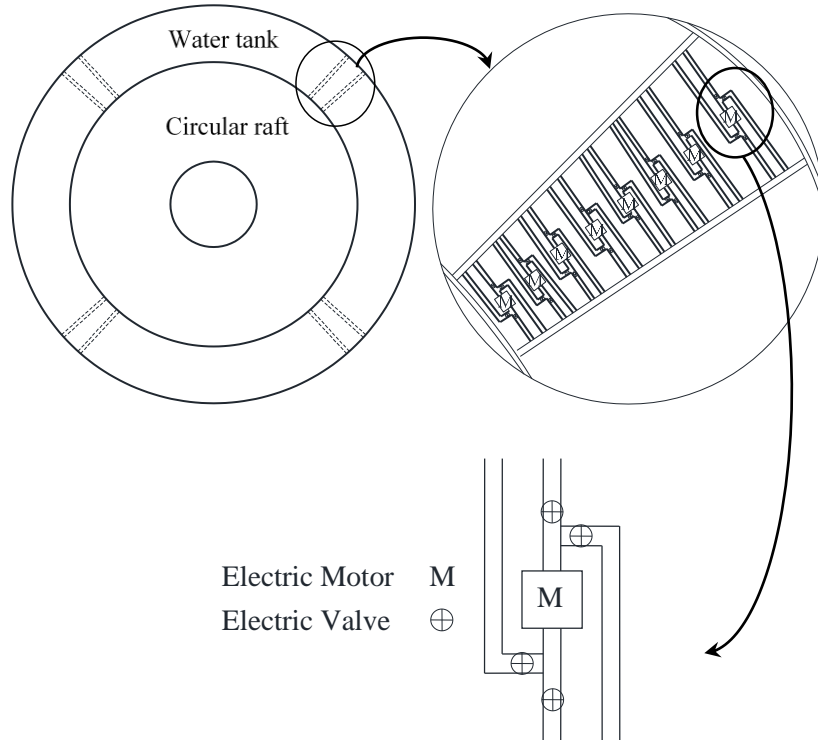

Figure 14 The first version of the water movement system, and the solution to make the motor move water in two directions between connecting compartments.

In the second version (Paper D), the water tank is divided into eight compartments, as shown in Figure 15, to improve the foundation's geotechnical behaviour. The water movement systems are designed with a number of pipes with valves to move half the water volume of the filled tank using gravity alone and with a number of electric motors to move the other half. In the last version, only two compartments will contain water to stabilise against the overturning moment. One of the advantages of this version is that a cost-efficient adjustment could be done to make this foundation able to support larger and taller units. After the end of the first turbine lifetime, an option is presented here to reuse this foundation and make it able to support taller and larger units. This option is considered using extra water volume to fill four compartments instead of two compartments.

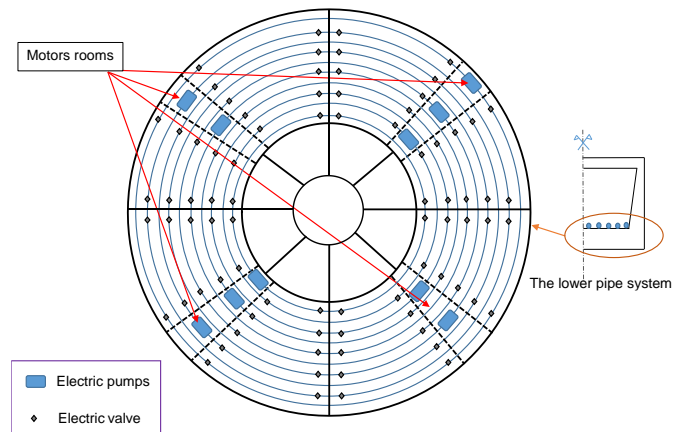

Figure 15 The improved water movement system.

The main advantage of using water as a movable load are:

- 1) to give stabilising moment almost equal to the overturning moment in case of normal wind speeds by controlling the amount of the required stability loads due to the wind speed.
- 2) half of the movable loads can be relocated to the required position using gravity alone requiring less electricity.
- 3) the structural design of the concrete sections will not change in the case of repowering and using extra water volume.
- 4) decreases the CO₂ emissions by using water to stabilise the foundation instead of extra concrete volume.

4.3.2 Using waggons filled with soil or rock as a movable load

Four waggons filled with a stone material are used to give a stabilising moment as shown in Figure 16a. The first step in the construction of a windmill is earthwork. Generally, excavation will be carried out to reach the foundation level. As mentioned, there is no backfill soil over this type of foundation. Therefore, it is better to use the soil which is excavated to fill the waggons. Some electric motors, sliding bearings and rubber wheels are used to move the waggons on a circular track as illustrated in Figure 16b. The number of the sliding bearings and the rubber wheels for each waggon are designed according to the maximum weight of the movable load. In this solution, the number of waggons should be an even number, and the reason is that half of the load will be moved from one side of the foundation to the opposite side to make balance in the case of no wind. The position of the waggons will rely on the wind direction.

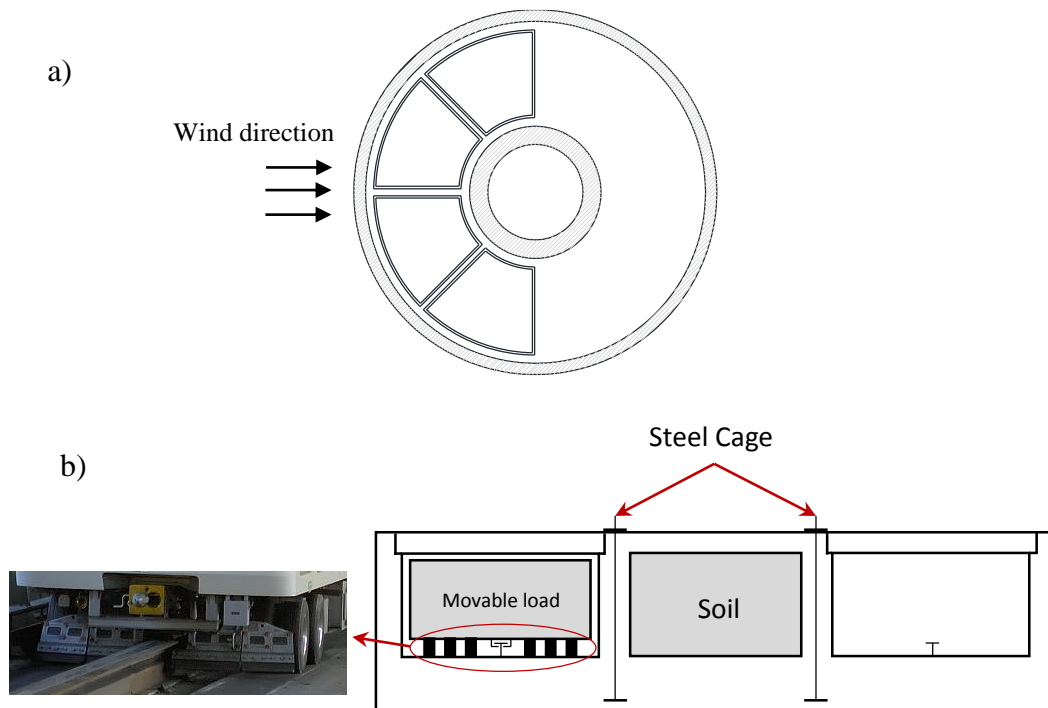

Figure 16 A cellular raft with an active system using movable waggons filled with soil as a stability load: a) plan view and b) cross section.

A control system will be used to react to the changing wind direction and speed that will move the four waggons to the desired position to provide the counter moment. Wind turbines already have control systems and therefore, the control system for the waggons will use information from the wind direction sensor and the wind speed sensor, that are already in the yaw system in wind turbines. The value of the overturning moment on the foundation depends on the wind speed. Therefore, for every wind speed range, there is a specific position for each waggon to give the best balance for the foundation. Figure 17 presents examples of the locations of the waggons to counteract the changing wind speed.

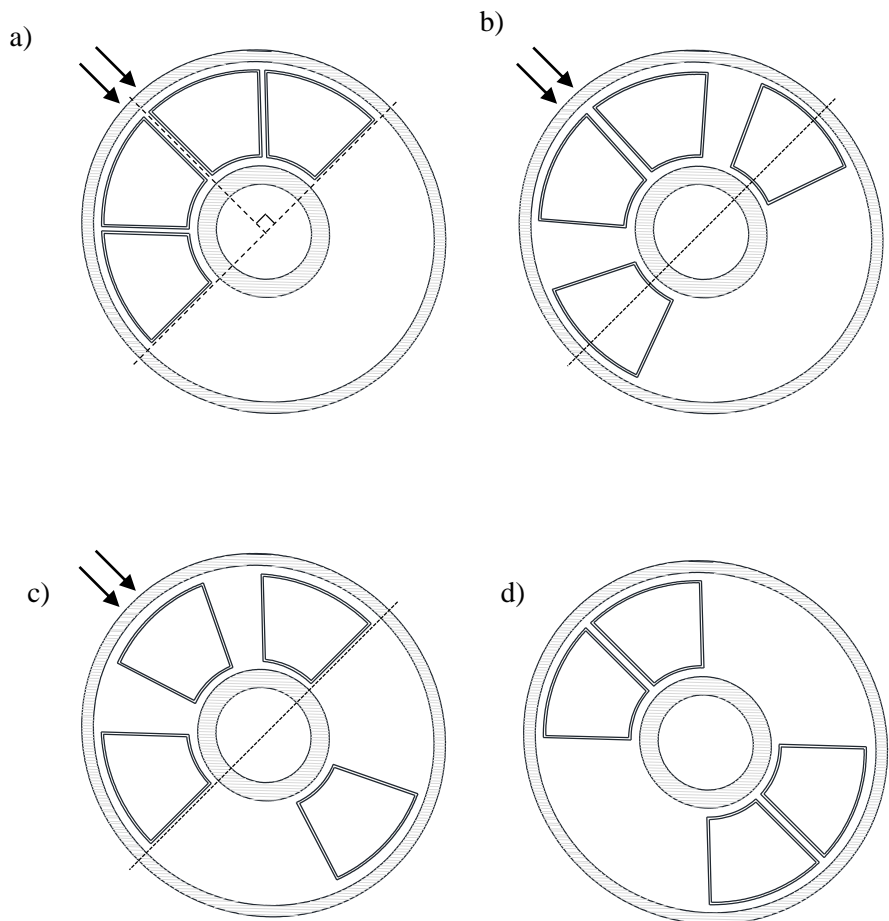

Figure 17 Examples of the location of the waggons in the case of a) the wind speed is in the operating conditions, b) and c) the wind speed is less than the turbine cut-in speed depending on the tower height and the foundation diameter, and d) there is no wind (wind speed is equal to zero).

One of the waggons positions in Figure 17b and Figure 17c will be used according to the tower height and the foundation diameter in the case of the wind speed is less than the turbine cut-in speed. To keep the waggons in the right position, signals from the wind direction sensor are monitored to check incoming wind direction. With this information, the control system of the active stabilisation system can actuate the motors to move the waggons as necessary. This control system will use a number of sensors to relocate the waggons in the right position. The yaw system speed for modern wind turbines is less than 0.5 degree per second [67]. This means that more than six minutes are required for modern wind turbines to turn 180°. The active system should be designed to be faster than the yaw system to move the waggons to the desired position before orienting the wind turbine rotor towards the wind. This will provide the system with the maximum stabilising moment before the extreme loading case occurs.

One of the solutions to increase the load capacity can be done by using solid rock such as dense quartz rock or basalt instead of soil in the four waggons. The unit weight of these

types of rock is almost 30 kN/m^3 . This will increase the stability moment by 36% or more compared to using four waggons filled with soil. Note that designing the foundation sections (thickness of the raft under the waggons) should consider the maximum stabilising load.

As mentioned, the position of the waggons depends on the wind direction and the wind speed. The stabilising moment due to the active system depends on the diameter of the foundation and the weight of the waggons. As mentioned, it could be the soil being excavated that fills the waggons. Therefore, the unit weight of the compacted soil in the waggons will depend on the soil properties of the site where the windmill is built. As shown from 60 geotechnical reports of 60 existing windmill sites in Sweden, developed by Tyréns AB, the unit weight of the soil ranges from 15 kN/m^3 to 22 kN/m^3 . Therefore, three values of the unit weight of the compacted soil in this range are used. These values are 16, 19, 22 kN/m^3 .

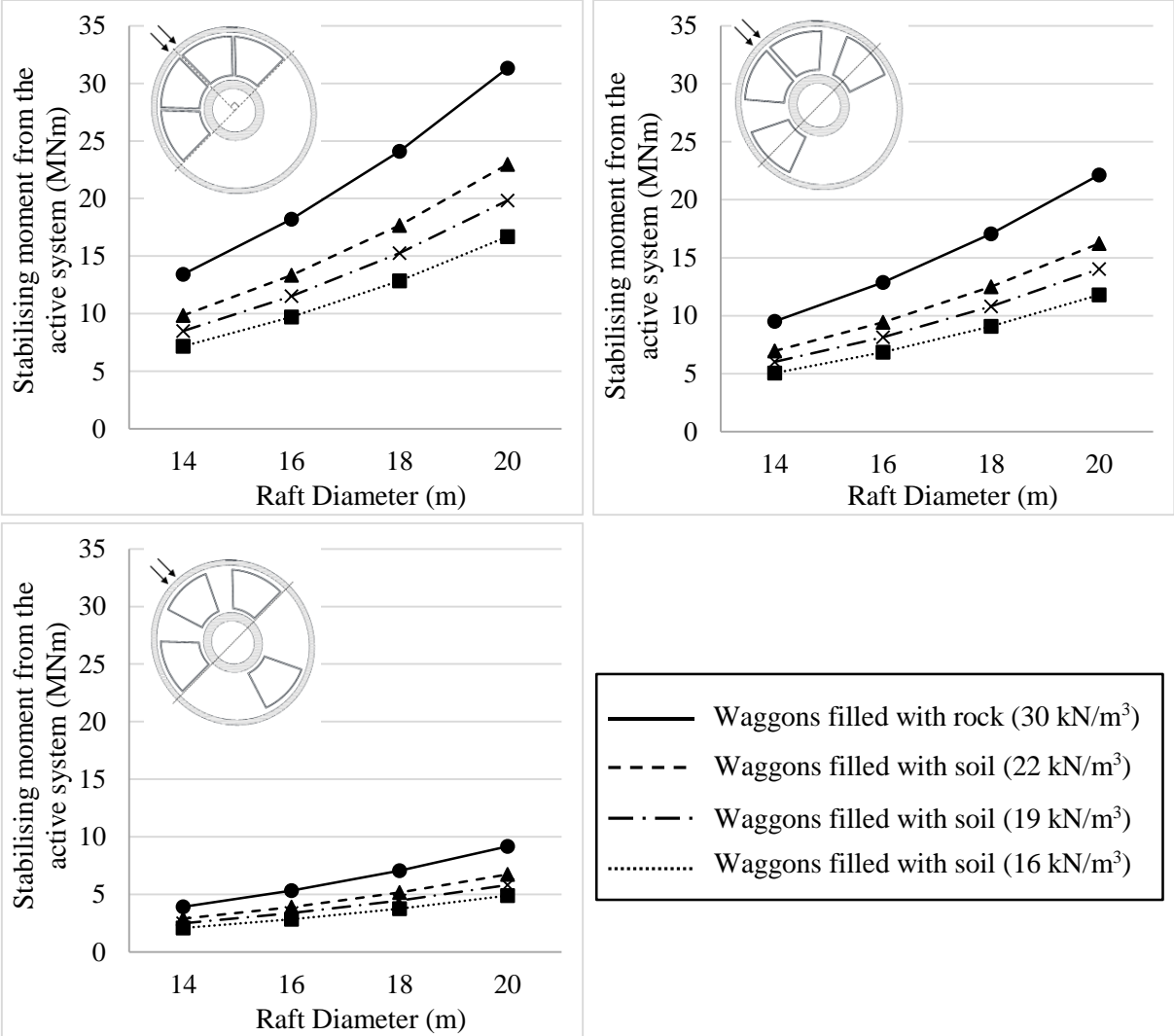

Figure 18 The stabilising moment from the active system.

The stabilising moment has been calculated for different foundation diameters. Figure 18 shows the resulting stability moment from the active system using foundation depth d_f equals 3 m. As can be seen, a very high stabilising moment can be achieved by using rock as a counterweight.

The main advantage of using waggons filled with a soil as a movable load are:

- 1) The stability loads can be increased by changing the materials in the waggons.
- 2) Less concrete volume is needed in the case of using movable waggons compared to a water tank.
- 3) The concrete sections can be designed as cracked sections relaxing the quality requirements (the cracks are not huge devastating cracks but only microcracks (0.1 mm in width)).
- 4) Using a natural material such as soil or rock to stabilise the foundation instead of an extra concrete volume decreases the CO₂ emissions.

5 Soil composition, properties and modelling

A brief description of the main soil relationships that are used in this work is given in this section. A soil mass consists of solid particles and voids as shown in Figure 19. The voids may contain water or air or both. The soil can be classified into three types on the basis of moisture content being saturated, dry, and partially saturated. In the saturated case the voids are full of water, in the dry case the voids are full of air, and in the partially saturated case, the voids are containing both water and air.

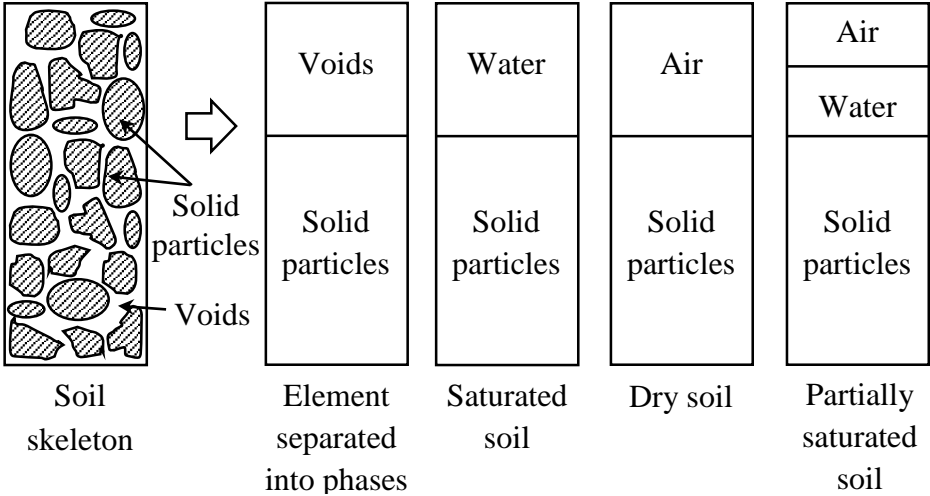

Figure 19 Soil classification on the basis of moisture content.

Some definitions are presented here to clarify the meaning of some soil properties used in the following sections. Friction angle, cohesion, and dilatancy angle are used in the analysis of the foundations placed on various soil profiles. Soil friction angle ϕ and cohesion c are considered as shear strength parameters of soils. The shear strength of soil is defined as the maximum shear resistance that the soil is capable of developing. The shear strength of the soil consists of the friction between the soil particles and the bonding or attraction at particle contacts which is called cohesion. Another parameter useful for more advanced soil calculations is dilatancy. This occurs in the soil during shear occurs because the grains in a compacted state are interlocking giving an expanding volume as shown in Figure 20. The angle of dilation ψ controls an amount of plastic volumetric strain developed during shearing in the plastic range.

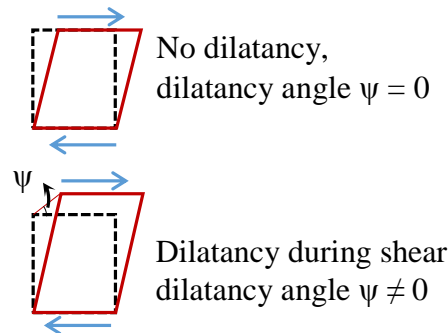

Figure 20 Dilatancy during shear.

The soil has pores that provide a passage for water. The amount of water and the water movement in the soil have a significant effect on the behaviour of the soil. When the soil layer is subjected to an external compressive pressure, a settlement may take place through rearrangement of the soil grains due to a change of the volume of the voids. In the case of saturated soil, the settlement can take place if water is pushed out of the voids. The permeability of the soil and the location of free draining boundary surfaces control the required time for the settlement to take place. The permeability of the soil can be defined as the capacity of the soil to permit water to pass through its void spaces [38]. In sand, settlement occurs immediately due to high permeability. However, in clay, settlement occurs after a long time due to low permeability.

Now to the concept of consolidation, an idealised system shown in Figure 21 can be used to describe the process of consolidation in a simple way. The spring in the idealised system represents the soil, and the water which fills the container represents the water in the soil. When the system is subjected to an external compressive pressure p and the drainage is prohibited, the total pressure is initially taken by the water as shown in Figure 21a. In this stage, the pore water pressure u is equal to the total pressure p and the spring is not compressed (no stress on the solid particles). If the valve in the idealised system is opened, the drainage of water will occur, and a part of the pressure is transferred to the spring, and it compresses as shown in Figure 21b. In this stage, the solid particles will take a part of the total pressure. After some time, the drainage of water will stop, and the spring alone will resist the applied pressure as shown in Figure 21c. In the final stage the effective pressure p' , which means the stress carried by the solid particles of the soil, is equal to the total pressure p .

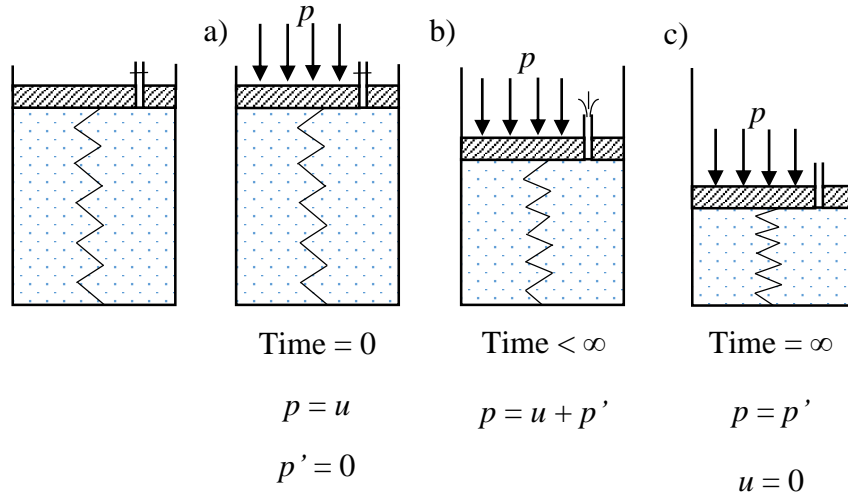

Figure 21 An idealised system to describe the process of consolidation.

Thus, consolidation is a process involving a settlement occurring at the same time with a flow of water out of the soil mass and with a slow transfer of the applied pressure from the pore water to the solid particles [39]. However, swelling can also occur, it is a process opposite to consolidation, which involves an increase in the water content due to an increase in the volume of the voids [39].

The drainage conditions, the thickness of the clay layer, and the excess load at the top of the clay are the main factors which decide the time taken for full consolidation [39]. Clay is called normally consolidated if the present effective pressure p_0' is the maximum pressure to which the layer has ever been subjected to at any time in its history [39]. However, clay is called overconsolidated if the soil was subjected, at one time in its history, to a larger effective pressure, p_c' , than the present effective pressure p_0' [39]. The larger effective pressure, p_c' in the case of overconsolidated clay is called preconsolidation pressure.

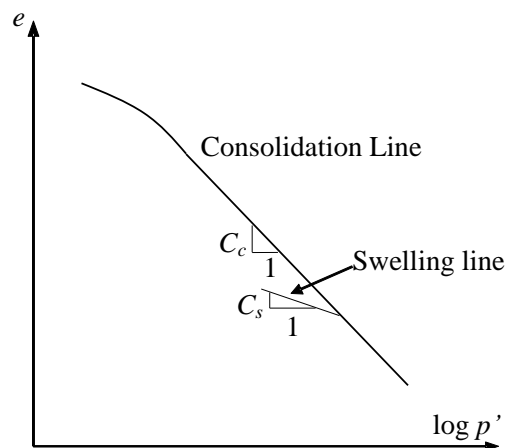

Figure 22 Void ratio versus effective stress plotted in a logarithmic scale.

In order to describe loading and unloading of soils, it is useful to look at void ratio in relation to the effective pressure p' according to Figure 22. Compression index C_c represents a deformation characteristic of soft soils. It also describes the variation of the void ratio e as a function of the change in effective pressure p' plotted in a logarithmic scale being the slope of the consolidation line in the linear part. On the other hand when the pressure is lowered, the swelling index C_s is the slope of the swelling line as shown in Figure 22. The swelling line is entered upon unloading of the soil. Reloading also follows the swelling line until the pressure exceeds the pre-consolidation pressure and then it begins to move down the consolidation line again.

5.1 Soil properties

A number of soil profiles are used in this thesis; a typical medium clay soil profile and a number of existing soil profiles. The existing soils are found near some cities in Sweden and near Port-Said city in Egypt. All the existing soils are in good wind spots. The main reasons for choosing these soil profiles are to show the geotechnical behaviour of the new foundations on different soil profiles. Moreover, to make a cost comparison according to Swedish and Egyptian construction costs, in order to check the cost difference in case of changing prices for work and material in order to find the best foundation solution for each case.

5.1.1 Port-Said soil properties

This section will focus on available Port-Said soil properties and the soil parameters that are required for analysing a circular raft with an active system and to compare it with a piled raft. A soil profile found near Port-Said city in Egypt was used in Paper C. According to Golder Associates [40], Port-Said soil consists of five layers. The first layer is a thin layer of very soft surface clay with an average thickness of 0.2 m in the northern part becoming 2 m in the south. Below the surface clay, there is fine sand with an average thickness of about 6 m. The sand grades downward through a transition zone into a soft clay again. The lower clay extends to an average depth of about 50 m below the ground surface. This clay layer rests in turn on a very hard clay. The groundwater in Port-Said lies 2 m below the natural ground level (NGL). A typical soil profile of Port-Said is shown in Figure 23.



Figure 23 a) Port-Said in Egypt, and b) soil profile.

The unit weight of the medium sand is about 20 kN/m^3 , the modulus of compressibility E_s of the medium sand layer is about 60 MPa and the drained Poisson's ratio is about 0.3 [40]. For the transition zone between the medium sand and the clay, the unit weight is about 16 kN/m^3 . The Young's modulus E is low with a mean about 6.5 MPa and the drained Poisson's ratio is about 0.3 [40]. For the lower clay layer, the modulus of compressibility E_s increases with depth and can be approximated by the following linear formula

$$E_s = E_{s0} (1 + 0.06 z) \quad (20)$$

E_s is the modulus of compressibility, E_{s0} is the initial modulus of compressibility ($E_{s0}=2\text{MN/m}^2$), and z is the depth measured from the upper surface of the lower clay layer in Figure 23.

The modulus of elasticity (Young's modulus) E is also required as input to soil models in FE programs. The modulus of elasticity E can be obtained from the following equation using Poisson's ratio ν [45] and Eq.(20) giving

$$E = E_s \frac{1-\nu-2\nu^2}{1-\nu} \quad (21)$$

5.1.2 Gothenburg soil properties

A soil profile found in Gothenburg city in Sweden is used in Paper B. The soil parameter values are summarised from a work of Olsson [46] based on some experimental tests. The investigated soil profile in the Gothenburg area according to Figure 24 contains a few meters of land fill followed by a deep soft clay layer of 40 m in thickness. Below the clay layer, there is a non-cohesive material a few meters in thickness on the rock [46]. The ground water level is about 1.5-2.0 m below the ground surface. The water content is about 80% in the top part of the clay, decreasing to around 50% at a depth of about 35 m. The unit weight is about 16 kN/m³, the Young's modulus E of the soft clay layer is about 5 MPa and the drained Poisson's ratio is about 0.3 [46].

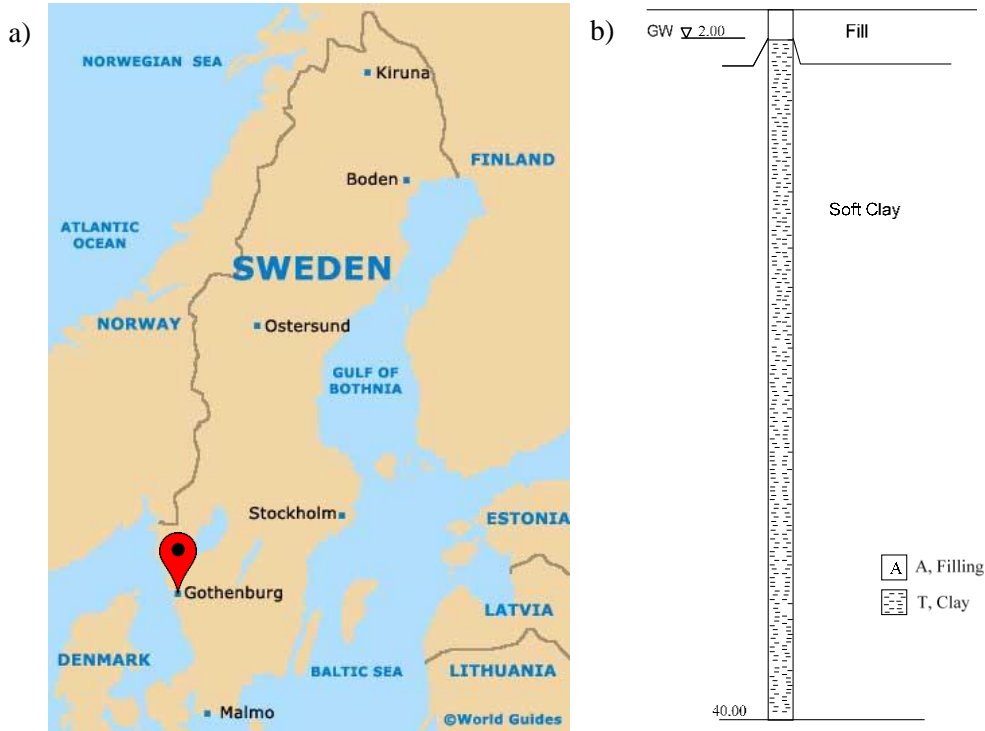

Figure 24 a) Gothenburg in Sweden, and b) soil profile.

5.1.3 Linköping soil properties

A soil profile found at an existing windmill site outside Linköping city is used in Paper D. In this site, the groundwater level has been measured to approximately 1.0 m below the ground surface. The soil profile is a clay layer reaching 26 m beneath the ground surface followed by a dense sand layer. The main properties of this soil are presented in Table 4, and the soil profile is plotted in Figure 25. The soil parameter values are summarised from a geotechnical report based on some experimental tests performed by Tyréns Company in Sweden [47].

Table 4 Main properties of an existing soil profile in Sweden

Soil type	Depth (m)	Unit weight γ (γ') (kN/m ³)	Young's modulus E (MPa)	Internal friction angle ϕ' (°)	Effective cohesion c' (kPa)	Undrained shear strength c_u (kPa)
Clay	0-3	18 (8)	3.8	30	3	20
	3-16	18 (8)	3.8	30	3	20-37
	16-21	18 (8)	3.8	30	3	37-50
	21-26	18 (8)	3.8	30	3	50



Figure 25 a) Linköping in Sweden, and b) soil profile.

5.1.4 Torsås soil properties

A soil profile found at an existing windmill site near Torsås municipality in Sweden is used. In this site, the groundwater level is at the ground surface, and the bedrock is 6 m beneath the ground surface. This soil can be classified as a sand soil. The unit weight is about 22 kN/m³, and the Young's modulus E of the sand layer is about 75 MPa and the drained Poisson's ratio is about 0.33 [48]. The location of Torsås municipality in Sweden is shown in Figure 26.



Figure 26 Torsås in Sweden.

5.1.5 Essunga soil properties

A soil profile found at an existing windmill site near Essunga municipality in Sweden is also used. The ground water level has been measured to approximately 1.2 m below the natural ground level. The bedrock is 24.5 m beneath the natural ground surface. This soil can be classified as a clay soil. The unit weight is about 18 kN/m^3 , the Young's modulus E of the clay layer is about 26 MPa, the drained Poisson's ratio is about 0.3 and the internal friction angle is about 33° . The location of Essunga municipality in Sweden is shown in Figure 27.



Figure 27 Essunga in Sweden.

5.2 Soil modelling

The geotechnical material model adopted in this work is the Mohr-Coulomb model, an elastic perfectly plastic model [49, 50]. It is used because it is common and its parameters are easy to obtain. It is used to model all the mentioned soil profiles.

The Mohr-Coulomb model requires five input parameters. The model's stress-strain behaviour is linear in the elastic range with two defining parameters being Young's modulus E and Poisson's ratio ν [51]. It also includes a failure criteria determined by the internal friction angle ϕ and the cohesion c . Moreover, the development of the plastic strains is determined by the dilatancy angle ψ . It is required to describe the flow rule (associated or non-associated flow rule) [50]. If the plastic potential function is equal to the yield function, the flow rule is called associated flow rule. However, if they are not equal, the flow rule is called non-associated flow rule. The behaviour of sand with both negative and positive dilatancy can be described by using a non-associated flow rule [51].

The failure criterion of the Mohr-Coulomb model regarding principal stresses is written [50] as:

$$\frac{\sigma_1' - \sigma_3'}{2} = c' \cos \phi' + \frac{\sigma_1' + \sigma_3'}{2} \sin \phi' \quad (22)$$

where σ_1' and σ_3' are the principal maximum and minimum effective stresses ($\sigma_1' > \sigma_3'$), c' is the effective cohesion, and ϕ' is the effective internal friction angle [50]. The yield surface plot is shown in Figure 28.

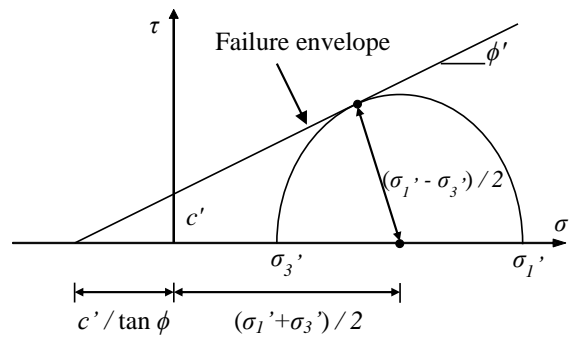

Figure 28 The Mohr-Coulomb failure criterion in the space of shear and normal stresses.

Failure occurs when $\frac{\sigma_1' - \sigma_3'}{2}$ is reaching the failure envelop. Other (apart from above mentioned) advantages of this model are its mathematical simplicity and the general level of acceptance.

6 FE Analysis of soil-foundation interaction

Almost all numerical finite element analyses in this work were carried out using the software Abaqus [54]. Three-dimensional finite element models of the foundations and soil were established. The soil and the foundations were modelled using three-dimensional deformable solid elements with different material models. The soil behaviour was included using an elastic-perfectly plastic constitutive model and the Mohr-Coulomb failure criterion [49, 50] according to the pervious discussion. Due to symmetry only half of the soil-structure system is modelled as shown in Figure 29. Foundations of diameter D with different shapes buried in the soil are studied. The mesh extend horizontally a distance of $2.5D$ or more from the edge of the foundations and vertically it extends $3D$ or until the bedrock. In the case of a stiff clay in Paper A, the mesh boundaries extend a distance of $2.5D$ from the edge of the foundations and $3D$ beneath the natural ground surface. The 20-node quadratic brick, reduced integration element (C3D20R) was selected to model the soil. A fine grid was applied around the footing and a coarse grid for the far field.

The soil nodes at the surrounding boundary of the model are fixed in the horizontal direction but not in the vertical direction. However, the nodes at the bottom boundary of the model are fully fixed in both the horizontal and vertical directions.

The foundation slabs are modelled as linear elastic three-dimensional structures with Young's modulus equal to 33 GPa, Poisson's ratio ν_s equals 0.2, and the unit weight γ equals 24 kN/m³. A steel ring with an I-shaped cross section is used as a realistic way to transfer the tower loads to the foundation. The steel ring is modelled as a linear elastic three-dimensional structure with Young's modulus equal to 210 GPa, Poisson's ratio $\nu_s = 0.3$, and the unit weight $\gamma = 78.5$ kN/m³. The 20-node quadratic brick, reduced integration element was also selected to model the raft foundations and the steel ring. A soft layer under the lower flange of the steel ring is modelled by leaving a 1 cm space between the lower flange and the concrete [55]. The reason for using this is to prevent a local punching failure from occurring [55]. In the case of using water in the active stabilization system, the stability load from water is modelled as pressure on the lower slab of the water tank. However, in the case of using movable waggons in the active stabilization system, the stability load from each wagon is modelled as a concentrated load on the middle sliding bearing as shown in Figure 30.

Concerning the analysis procedure, two steps are used in the deformation analyses. The first one is the geostatic step to make certain that equilibrium due to the weight is satisfied in the soil. The second step is the static general step to apply the tower loads. However, three

steps are used in the load failure analyses; the first two are the same as above, and the third step is to apply the overturning moment until failure. For all the cases in this work, a convergence study was performed by using meshes with different element size for the soil under the foundation. The results were shown to be convergent.

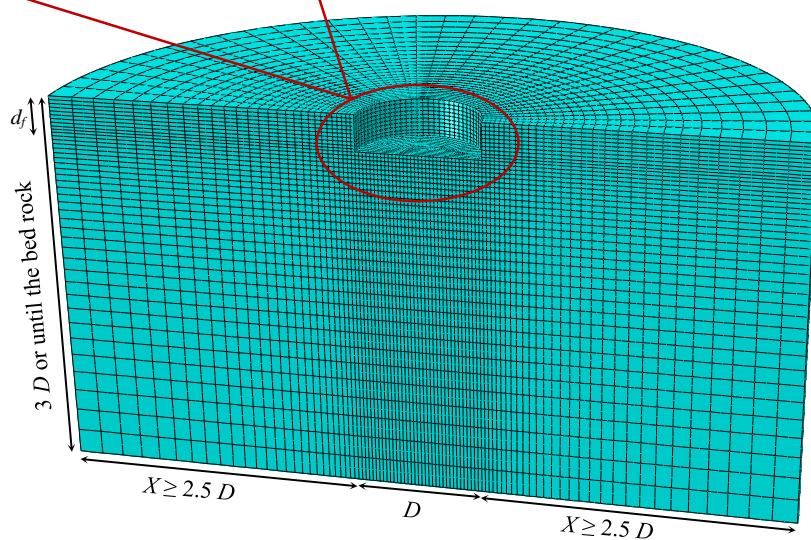
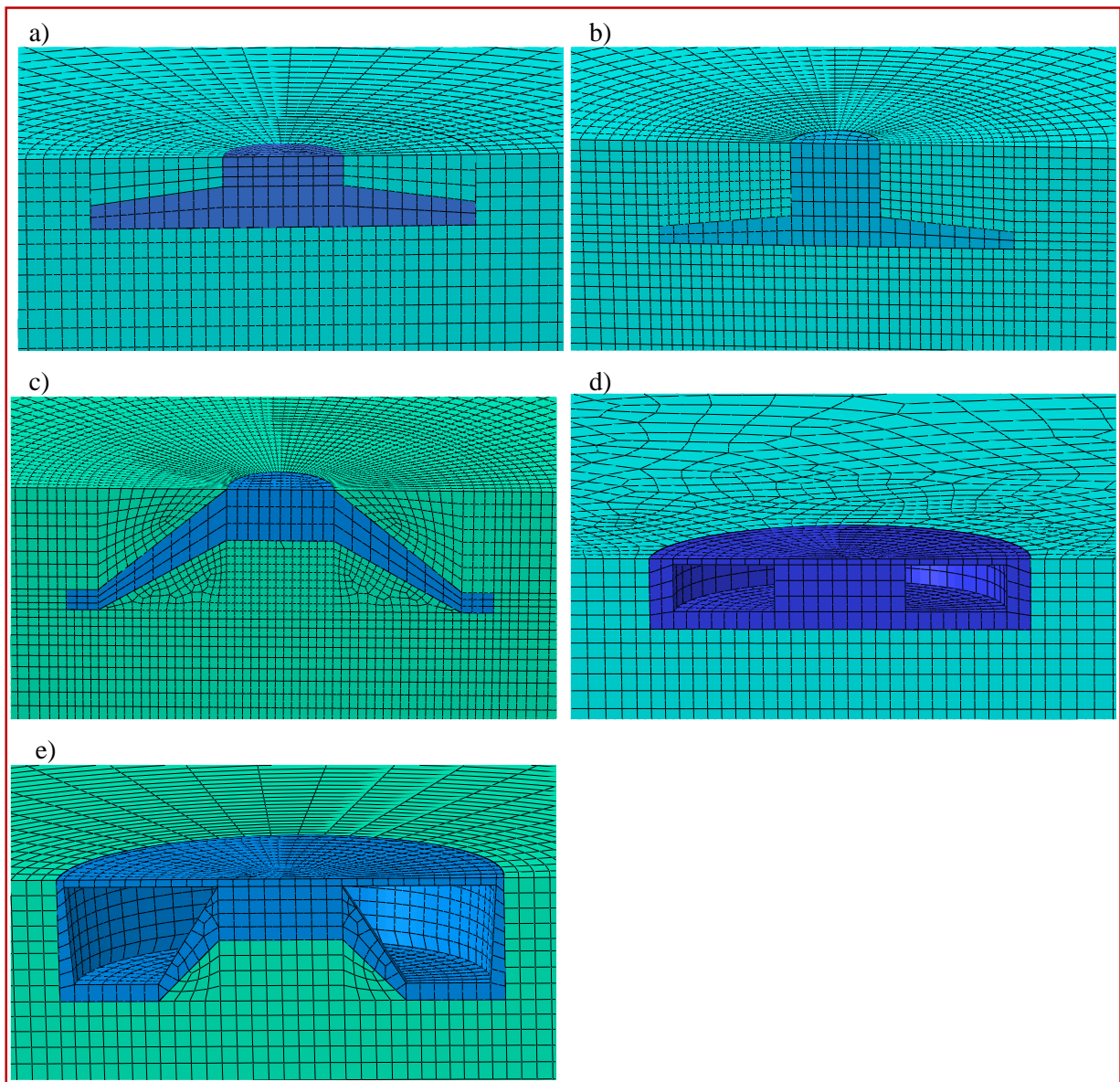

Figure 29 Finite element mesh for a) a traditional flat raft, b) a deep flat raft, c) a conical raft, d) a cellular raft with an active system, and e) a conical footing with an active system.

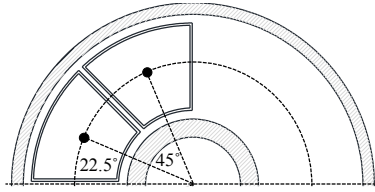

Figure 30 The position of the stability loads from the waggon wheels used in the FE model.

Due to the extremely high overturning moment acting on windmill foundations, a part of the foundation base area will be subjected to tension stresses, and it is well known that soil cannot carry any tension stresses. Therefore, the contact area between the soil and the foundation is expected to be decreased as the overturning moment increases. The separation between the foundation and the soil can be modelled in Abaqus with a normal behaviour using the constraint enforcement method and pressure-overclosure as hard contact, allowing separation. Due to the horizontal force from the wind, sliding can occur. The tangential behaviour is modelled in Abaqus with a friction coefficient of 0.3 used between the foundation and the clay soil. However, the friction coefficient becomes 0.5 in the case of sand soil. Due to the deformation of the foundation, friction between the foundation's edge and the soil will occur requiring the same tangential frictional modelling. The bond between the steel ring and the concrete is modelled in a similar way by using a tangential behaviour with a much higher friction coefficient equal to 0.9. The effect of the friction coefficient between the steel ring and concrete slab was found to be minor [55]. To connect the soil in the region over the foundation to the soil in the region beside the foundation, the so-called mesh tie constraint was adopted in some cases and a tangential behaviour with a friction coefficient in other cases.

7 Summary of appended publications

The second part of this dissertation consists of six appended papers. A summary of these papers is presented here.

7.1 Paper A

A comparative study of three onshore wind turbine foundations

W. M. Mohamed and P.E. Austrell

Journal of Computers and Geotechnics

Summary

This work focuses on the geotechnical behaviour of three foundation solutions for onshore windmills. It shows the difference between a conical raft, a traditional flat raft, and a deep flat raft. The results show that a conical raft has higher load carrying capacity than a flat circular raft. In the case of dry soils, it can be concluded that increasing the foundation base level is a good solution to decrease the required diameter. The shell angle θ has a minor effect on the required diameter in the case of the ground water level being at the ground surface. Also, the results show that, it is favorable to use the conical shape if the location of the groundwater is at or near the ground surface, to decrease the effect of the uplift force on the foundation. The the conical shape requires smaller diameters than the flat one to pass the requirements of the geotechnical design, and this may decrease the foundation construction time at the site. Conical rafts need smaller quantities of material than flat rafts. The total concrete volume and the steel weight were reduced by 30% and 16%, respectively. However, the total excavation volume was approximately 11% more than the required excavation volume of a conventional flat circular raft. Also, a deep excavation requires more work. Therefore, the conical shape with $\theta = 120^\circ$ can be the best economical alternative to the flat shape especially in countries where labour to material cost ratio is low.

Contributions by Wael M. Mohamed

Wael M. Mohamed contributed to the work by being the main author of the paper and planning the research tasks. He created FE models, performed calculations, and came to the conclusions.

7.2 Paper B

Optimization of wind turbine foundations for poor soil

Wael M. Mohamed and P.E. Austrell

Based on a paper published in the Proceedings of COMPDYN 2015, Crete; Greece; 25 - 27 May 2015

Summary

The main focus of this work is to investigate the geotechnical behaviour of a new foundation solution placed on a soil with weak properties. The evaluated new solution is a flat circular raft surrounded by an active stabilisation system using a water tank. The concept of an active stabilization system is a novel idea using a movable weight to stabilise against the overturning moment. The first version of the water movement system is used in this study. A comparative study of two foundation solutions, a flat circular raft surrounded by the mentioned active stabilisation system and a piled raft with long friction piles, has been performed using finite element simulations. An existing soil profile found at Gothenburg city in Sweden is used in this study. The results show that the new foundation solution decreases the differential settlement compared to a piled raft with 28 m pile length. Also, a cost comparison between the new foundation and a piled raft has been done using Swedish construction costs. It shows that the new foundation solution gives a significant decrease in the initial foundation costs compared to a piled raft with 28 m pile length. Also, the dynamic response of the whole structure using soil-foundation interaction was investigated. It is shown that the entire system of a 2MW wind turbine using the new foundation solution successfully avoids resonance from the rotor excitations in the case of.

Contributions by Wael M. Mohamed

Wael M. Mohamed contributed to the work by being the main author of the paper and planning the research by creating FE models, performing calculations and drawing conclusions.

7.3 Paper C

A new onshore wind turbine foundation system for poor soil

Wael M. Mohamed and P.E. Austrell

Based on a paper published in the Proceedings of EWEA 2015, Paris; France; 17 - 20
November 2015

Summary

The geotechnical behaviour of an innovative foundation solution, a flat circular raft surrounded by an active system and two types of piled rafts are investigated. A cost comparison is made between the foundation solutions according to Egyptian construction costs. Also, the dynamic response of the whole structure using soil-foundation interaction was investigated. A layered soil profile found in Port-Said region in Egypt is utilised in this study. Two water movement systems were compared in this study to show the effect on the system cost of the motors flow rate and of using pipes to move half of the water volume. In terms of tilting and settlement, the results show that using an active stabilisation system decreases the tilting of the foundation compared to using friction piles with 24 m length. However, the settlement of the new foundation solution increased compared to the settlement of a piled raft with long friction piles. Also, it is shown that using the new foundation system gives a significant decrease in the initial foundation cost compared to using a piled raft. The results showed that the entire windmill system using the new foundation solution successfully avoids resonance from the rotor excitations in the case of.

Contributions by Wael M. Mohamed

Wael M. Mohamed contributed to the work by being the main author of the paper and planning the research tasks. He created FE models, performed calculations, and came to the conclusions.

7.4 Paper D

A reusable active foundation solution for onshore wind turbines

Wael M. Mohamed, P.E. Austrell, and Ola Dahlblom

Submitted for publication

Summary

A comparative study of two foundation solutions, a traditional circular raft and a conical footing with an active stabilisation system, has been performed numerically using finite element simulations. The load capacity of the mentioned foundation solutions considering an existing soil profile in Linköping city in Sweden is studied here. In this study, a continuation of the previous work, the active system is improved to be cheaper to build and to make the foundation having a better geotechnical behaviour. The comparison between the active system versions shows that using pipe systems to move half of the water volume is very cost effective compared to using electric motors only to move the whole water volume. Also, the number of motors has the largest effect on the cost. Using pipe systems with electric valves to connect all the compartments is an efficient way to save money and time. The most important advantage of the improved water movement system in this study is that the system can move the water directly to the required compartments (not just through the nearest compartments). Also, using eight compartments improves the overturning resistance in all the load cases. The results show that a conical footing with an active stabilisation system reduces the failure probability of onshore windmills compared to a circular flat raft. Moreover, it is possible to increase the load capacity of the new foundation solution by doing adjustments. This makes the new foundation able to resist larger overturning loads and make it able to support a larger turbine and taller tower in a cost effective manner. Concerning the environmental impact of using a conical footing with an active stabilisation system, the results show that reusing the proposed foundation solution by adding more water volume can save a significant amount of CO₂ compared to the complete dismantling of an existing raft foundation and replacing it with a larger one.

Contributions by Wael M. Mohamed

Wael M. Mohamed contributed to the work by being the main author of the paper and planning the research by creating FE models, performing calculations and drawing conclusions.

7.5 Paper E

A new and reusable foundation solution for onshore windmills

Wael M. Mohamed, P.E. Austrell, and Ola Dahlblom

Submitted for publication

Summary

The main focus of this work is to propose and investigate a new foundation solution that can allow wind power projects to be updated with taller and larger units. This study investigates the load capacity of a cellular raft with an active stabilisation system. Also, it shows the required adjustments to make the foundation able to support taller towers and larger turbines. The active system uses movable waggons filled with a compacted soil or a solid rock as a movable load. It was shown that the load capacity of a cellular raft with such an active system is larger than the load capacity of a traditional circular raft. A raft with an active stabilisation system can be used to speed up the repowering construction time and reduce the environmental impact. Moreover, reusing this new foundation can save a significant amount of CO₂ from manufacturing of concrete. Further studies will investigate the required construction time and the foundation cost of the new foundation solution.

Contributions by Wael M. Mohamed

Wael M. Mohamed contributed to the work by being the main author of the paper and planning the research tasks. He created FE models, performed calculations, and came to the conclusions.

7.6 Paper F

The possibility to reuse onshore windmill foundations from the geotechnical point of view

Wael M. Mohamed and P.E. Austrell

Submitted for publication

Summary

This study focuses on the effect of increasing the stability loads on the load capacity of raft foundations. Increasing the stability loads is investigated in terms of filling the lower part of the tower with soil or increasing the unit weight of the backfill soil. Sensitivity analyses are presented to show the impact of these changes. Various loading conditions and soil properties are investigated looking at bearing capacity of the soil and evaluating the risk of overturning. Also, the load capacity of an existing raft foundation found at a wind farm in Torsås municipality in Sweden is investigated. The results show that increasing the stability loads is a good solution to increase the load capacity of existing raft foundations. Increasing the stability loads by using natural materials will also provide a significant reduction in the carbon dioxide emissions compared to the complete dismantling of the existing foundations and building new with larger dimensions.

Contributions by Wael M. Mohamed

Wael M. Mohamed contributed to the work by being the main author of the paper and planning the research by creating FE models, performing calculations and drawing conclusions.

8 Concluding remarks

The aim of the research discussed in this thesis is to find new and reusable foundation solutions able to reduce the failure probability of onshore windmills, speed up the repowering construction time and reduce the environmental impact. Also, it aims to present a number of cost-efficient solutions which give the existing windmill foundations the ability to be reusable. Windmill structures experience a high horizontal wind load giving an extremely high overturning moment on the foundation. In addition to this high overturning moment, windmill structures have a relatively low vertical load. The combination of a low vertical load and an extremely high overturning moment makes the structure less stable against overturning. The traditional way to solve this problem uses a foundation with a massive concrete volume to resist the overturning moment. This work focused on presenting new foundation solutions which using natural materials such as water, soil, and rock to improve the stability of the windmill structures. The present work is a part of the development of efficient and sustainable foundation solutions for onshore windmills.

8.1 Conclusions

The results and conclusions presented in this work are an important step towards finding new and reusable foundation solutions able to reduce the failure probability of onshore windmills, speed up the repowering construction time and reduce the environmental impact. A number of case studies were investigated to illustrate the behaviour of the new foundation solutions and compared with the behaviour of the traditional solutions. A comparative study between a raft with a conical shape and the traditional raft foundation show that it is favorable to use a conical raft if the location of the groundwater is at or near the ground surface to decrease the effect of the uplift force on the foundation. Also, a conical raft requires a smaller diameter than a flat raft to pass the geotechnical design requirements, and this may decrease the foundation construction time at the site and save money. A conical raft with $\theta = 120^\circ$ can be the best cost-efficient alternative to a flat raft especially in countries where labour to material cost ratio is low.

For soils containing deep soft clay layers, a raft surrounded by an active stabilisation system overcomes the tilting problem giving a tilting lower than a piled raft in many existing soil profiles. Using a piled raft gives the lowest magnitude of settlement. However, a raft surrounded by a water tank gives the lowest value of tilting. The figures used in the cost comparison were for a particular load case, a typical 2 MW load case. This was done in

order to clarify the difference between the new proposed solution's costs and the traditional foundation's costs. A raft surrounded by a water tank decreases the foundation budget compared to a piled raft with long friction piles.

Using an active stabilisation system gives a significant improvement in the load capacity of the foundations compared to the traditional raft foundations. It is possible to increase the load capacity of the new foundation solutions by doing cost-efficient adjustments. These adjustments make the new foundations able to resist higher overturning loads and make it able to support a larger turbine and taller tower. Concerning the environmental impact of using a raft with an active stabilisation system, it is shown that reusing this foundation by adding extra stability loads can save a significant amount of CO₂ compared to the complete dismantel an existing raft and replace it with a larger one. Finally, increasing the stability loads of an existing windmill structure by using natural materials is a good solution to increase the load capacity of the foundation and makes it able to support extra overturning loads. Reusing windmill foundations will speed up the repowering construction time, save money, and reduce the environmental impact.

8.2 Proposals for future work

Many countries are interested in reducing the carbon dioxide emissions by reusing various products to decrease the global warming. As mentioned in the introduction, the reuse of foundations for projects at urban sites was started in 2003 to inspire geotechnical engineers to consider reusing foundations [15]. Therefore, geotechnical engineers can help saving the environment by learning how to improve the traditional foundation solutions, find sustainable foundation solutions, and reuse the foundations. Reusing windmill foundations and make them able to support larger overturning loads is an interesting topic for future studies.

Some propositions for future work:

- 1) Study the behaviour of the proposed foundation solutions in the case of catastrophic loading conditions.
- 2) The effect of the earthquake loads on the behaviour of a raft surrounded by a water tank.
- 3) Study the effect of increasing the stability and overturning loads on the structural design of the traditional foundation solutions.
- 4) Find the new design requirements for the traditional foundations considering the reuse of foundations.

- 5) Find other innovative solutions to improve the load capacity of the existing windmill foundations.
- 6) Study the effect of water sloshing on the dynamic behaviour of windmills in the case of using water as a movable loads in the foundation.

Bibliography

- [1] Energimyndigheten (2007) Nytt planeringsmål för vindkraften år 2020, Report ER 2007: 45. (in Swedish)
- [2] The Swedish Institute (2013) Available at: <https://sweden.se/wp-content/uploads/2013/11/Energy-Low-Res.pdf>
- [3] Annual Report from Egyptian Electricity Holding Company (2015/2016). The Egyptian Ministry of Electricity and Energy. (In Arabic) Available at: http://www.moee.gov.eg/test_new/PDFReports/REP2015-2016.pdf
- [4] Lantz E, Leventhal M, Baring-Gould I (2013) Wind Power Project Repowering: Financial Feasibility, Decision Drivers, and Supply Chain Effects. The National Renewable Energy Laboratory technical report. Available at: <http://www.nrel.gov/docs/fy14osti/60535.pdf>
- [5] Gray T (2013) Repowering gives new life to old wind sites. Available at: <http://www.aweablog.org/repowering-gives-new-life-to-old-wind-sites/>
- [6] International Renewable Energy Agency (2012) 30 Years of Policies for Wind Energy -Lessons from 12 Wind Energy Markets. Available at: https://www.irena.org/DocumentDownloads/Publications/IRENA_GWEC_WindReport_Full.pdf
- [7] Buchsbaum L, Patel S (2016) Wind turbine repowering is on the horizon. Power Magazine. Available at: <http://www.powermag.com/wind-turbine-repowering-horizon/?pagenum=2>
- [8] Malhotra VM (2000) Role of supplementary cementing materials in reducing greenhouse gas emissions. O.E. Gjorv, K. Sakai (Eds.), Concrete technology for a sustainable development in the 21st century, E&FN Spon, London, pp. 226-235.
- [9] Huntzinger DN, Eatmon TD (2009) A life-cycle assessment of cement manufacturing: comparing traditional process with alternative technologies. Journal of Cleaner Production, 17 (7), pp. 668-675.
- [10] Contech Engineered solutions [cited at 2016-01-15] available at: <http://www.conteches.com/Markets/Wind-Turbine-Foundations/Tensionless-Pier-Wind-Turbine-Foundation>

- [11] Megavind (2016), Strategy for Extending the Useful Lifetime of a Wind Turbine, [cited 2017 June 12]. Available at: <http://www.vindmoellegodkendelse.dk/media/1163/strategy-for-extending-the-useful-lifetime-of-a-wind-turbine.pdf>.
- [12] Abdel-Rahman M. (1996) Geotechnical behaviour of shell foundations. Doctoral thesis, Concordia University, Canada.
- [13] Huat BBK, Mohammed TA. (2006) Finite Element Study Using FE Code (PLAXIS) on the Geotechnical Behaviour of Shell Footings. *Journal of Computer Science* 2 (1): 104-108.
- [14] Colmenares JE, Kang SR, Shin YJ, Shin JH (2013) Ultimate bearing capacity of conical shell foundation. The world congress on advances in structural engineering and mechanics. Jeju, Korea.
- [15] Sheil B (2017) Numerical simulations of the reuse of piled raft foundations in clay. *Acta Geotechnica*: 1-13.
- [16] Butcher AP, Powell JJ M, Skinner HD (2006) Reuse of Foundations for Urban Sites - A Best Practice Handbook. Published by IHS BRE Press, UK.
- [17] Butcher AP, Powell JJ M, Skinner HD (2006) Reuse of Foundations for Urban Sites – Proceeding of the International Conference. Watford, UK, 19-20 October 2006. Published by IHS BRE Press, UK.
- [18] Chapman T, Anderson S, Windle J (2007) Reuse of foundations. Published by CIRIA, London, UK.
- [19] Watanabe T, Ishizaki S, Tomita N, Kawamoto SI, Tatsuno S. (2015) Reuse of existing bored piles for high-rise building foundation. Proceedings of the 15th Asian regional conference on soil mechanics and geotechnical engineering. November 9-13. Japan.
- [20] Laefer DF, Manke JP. (2008) Building reuse assessment for sustainable urban reconstruction. *Journal of Construction Engineering and Management*, 134(3):212-217.
- [21] Lehane BM, Jardine RJ (2003) Effects of long-term pre-loading on the performance of a footing on clay. *Géotechnique* 53(8):689–695.
- [22] Zdravkovic L, Potts DM, Jackson C (2003) Numerical study of the effect of preloading on undrained bearing capacity. *International Journal of Geomechanics* 3(1):1–10.

- [23] Det Norske Veritas, Copenhagen and Wind Energy Department, Risø National Laboratory (2002). Guidelines for Design of Wind Turbines, Second Edition, pp.187-221.
- [24] Teng WC. (1962) Foundation Design. Prentice Hall Professional Technical Reference. (ISBN-13:978-013329805).
- [25] Szerzo Á. (2012) Optimization of foundation solutions for wind turbines. *Mathematical Modeling in Civil Engineering*. 4:215-224.
- [26] Terzaghi K. Theoretical soil mechanics. New York: Wiley; 1943.
- [27] Bowles JE. Foundation Analysis and Design, 5th Ed., USA: McGraw-Hill; 1997.
- [28] Morgan K, Ntambakwa E. (2008) Wind Turbine Foundation Behaviour and Design Considerations. AWEAWIND POWER Conference, Houston.
- [29] Meyerhof GG. The ultimate bearing capacity of foundations. *Géotechnique*, 1951;2:301–332.
- [30] European Committee for Standardization (ECS), Eurocode 7 – Geotechnical design – Part 1: General rules, Swedish Edition SS-EN1997-1, Swedish Standards Institute (SIS), Stockholm; 2008.
- [31] Skampton AW. The bearing capacity of clays. *Proc. Build. Res. Congr.* London: 1951.
- [32] Das BM. Principles of Foundation Engineering. 6th ed. New Delhi: Cengage Learning; 2007.
- [33] Hansen B (1978). Geoteknik og Fundering, Del II Forelæsningsnotater til Kursus 5821 – Geoteknik 2, Notat nr. 16, Den private ingeniørfond ved Danmarks tekniske Højskole, Lyngby, Denmark.
- [34] Snyder B, Kaiser MJ. (2009). Ecological and economic cost-benefit analysis of offshore wind energy. *Renewable Energy*, 34, 1567-1578.
- [35] Engström S, Lyrner T, Hassanzadeh M, Stalin T, Johansson J (2010). Tall towers for large wind turbines. Report from Vindforsk project V-342 Höga torn för vindkraftverk.
- [36] Junginger M, Faaij A, Turkenburg WC (2004). Cost reduction prospects for offshore wind farms. *Wind engineering*, 28(1), 97-118.

- [37] Manwell JF, Macleod J, Wright S, Ditullio L and McGowan JG (2006). Hull Wind II: A Case Study of the Development of a Second Large Wind Turbine Installation in the Town of Hull, MA. 2006 American wind energy wind association windpower conference. Available at:
<http://www.ceere.org/rerl/publications/published/2006/AWEA%202006%20Hull%20II.pdf>
- [38] Raj P (2008) Soil Mechanics & Foundation Engineering. Published by Dorling Kindersley. India. ISBN: 81-317-117-3.
- [39] Murthy VNS. (2003) Geotechnical Engineering: Principles and Practices of Soil Mechanics and Foundation Engineering. ISBN 0-8247-0873-3.
- [40] Golder Associates (1979) Geotechnical Report for Port-Said Area. Port-Said, Egypt.
- [41] Nishida Y (1956). A brief note on compression index of soils. Journal of Soil Mechanics and Foundations Division, ASCE, 82, SM3, 1027-(1-14).
- [42] DeBeer EE. 1965. Bearing capacity and settlement of shallow foundations on sand. Proceedings, Symposium on Bearing Capacity Settlement of Foundations, Duke University, Durham, N.C., 15-33.
- [43] DeBeer E, Martens A. 1957. Method of computation of an upper limit for the influence of heterogeneity of sand layers in the settlement of bridges. Proceedings, 4th International Conference on Soil Mechanics and Foundation Engineering, London, 1: 275-281.
- [44] Reda A. (2009) Optimization of piled raft in Port-Said. M.Sc. Thesis, Faculty of Engineering, Suez Canal University, Port-said, Egypt.
- [45] Kany M, El Gendy M, and El Gendy A. Computer Analysis and Design of Foundations. Volume I: Theory used in the formulation of ELPLA. Chapter 8.
- [46] Olsson M (2010) Calculating long term settlement in soft clays with special focus on the Gothenburg region. Thesis for the Degree of Licentiate of Eng., Department of Civil & Environmental Eng., Chalmers University of Technology, Gothenburg, Sweden.
- [47] Nilsson A, Palm M (2011) Geotechnical investigation in Lindärva 5:3, Linköping. Unpublished report no. 218792-56 developed by Tyréns Company.
- [48] Nilsson A, Palm M (2011) Teknisk undersökning PM geoteknik Påboda 8:7, Torsås kommun. Unpublished report no. 218792-59 developed by Tyréns Company.

- [49] Ottosen NS, Ristinmaa M (2005) The Mechanics of Constitutive Modeling. Elsevier Ltd. Chapter 8, pp 165-173.
- [50] Potts DM, Zdravkovic L (1999) Finite element analysis in geotechnical engineering theory. Thomas Telford, London, UK, Section 7, pp.151-155.
- [51] Ti KS, Huat BBK, Noorzaei J, Jaafar MS, Sew GS. (2009) A review of basic soil constitutive models for geotechnical application. Electronic Journal of Geotechnical Engineering. 14:1–18.
- [52] Labuz J, Zang A (2012) Mohr-Coulomb Failure Criterion. Rock Mechanics and Rock Engineering, 45, 6, 975-979.
- [53] Al-Ajmi AM, Zimmerman RW (2005) Relation between the Mogi and the Coulomb failure criteria. Int. J. Rock Mech. Miner. Sci. 42 (3), 431–439.
- [54] Hibbitt D, Karlsson B, Sorensen P. Abaqus 6.12-3 Manual. 2012.
- [55] Maunu P. (2008) Design of wind turbine foundation slabs. Master's Thesis, Lulea University of Technology.
- [56] ABAQUS Theory Manual, Version 6.12. Simulia.
- [57] Buchsbaum L, Patel S. Wind turbine repowering is on the horizon. Power Magazine. 2016. Available at: <http://www.powermag.com/wind-turbine-repowering-horizon/?pagenum=2>
- [58] Online page. Available at: <http://chcsa.co.za/?p=1685>
- [59] Online page. Available at: <http://www.conteches.com/Markets/Wind-Turbine-Foundations/Tensionless-Pier-Wind-Turbine-Foundation>
- [60] Online page. Available at: <http://www.windfarmbop.com/geotechnical-parameters-for-wyg-foundations-design/>
- [61] Limit state design [Cited at 2016-04-04]
<https://www.scribd.com/doc/51971809/ULS-and-SLS#>
- [62] Vestas V90-2MW. Available at:
https://www.vestas.com/en/products/turbines/v90%20_0_mw#!about
- [63] Ishii H, Ishihara T (2010) Numerical study of maximum wind load on wind turbine towers under operating conditions. The Fifth International Symposium on Computational Wind Engineering (CWE2010), Chapel Hill, North Carolina, USA.
- [64] Kawai H, Michishia K, Deguchi A (2008) Design wind loads on a wind turbine for strong wind. BBAA VI International Colloquium on: Bluff Bodies Aerodynamics & Applications. Milano, Italy.

- [65] Svensson H (2010). Design of foundations for wind turbines. Report TVSM-5173, Master's dissertation, structural mechanics. Lund University, Sweden. Available at: www.byggmek.lth.se/fileadmin/byggnadsmekanik/publications/tvsm5000/web5173.pdf
- [66] Manwell JF, McGowan JG, Rogers AL (2010) Wind Energy Explained: Theory, Design and Application. Second Edition. John Wiley & Sons. pp. 87.
- [67] Vestas Wind Systems (2010) General Specification V90–1.8/2.0 MW 50 Hz VCS. Document no.: 0004-6207 V05. Available from: [http://ventderaison.eu/gembloux/eie_ABO-WIND/Annexes/Annexe N 1 Courbe acoustique V90.pdf](http://ventderaison.eu/gembloux/eie_ABO-WIND/Annexes/Annexe_N_1_Courbe_acoustique_V90.pdf)
- [68] Lang PJ (2012) Sensitivity of shallow wind turbine foundation design and soil response to geotechnical variance with construction cost implications. Master's dissertation, Civil and Environmental Department. University of Wisconsin-Madison.
- [69] Ishihara T, Ishii H, Nishio M (2011) Maximum wind loads on a wind turbine under operating conditions. EWEA 2011. Brussels, Belgium.