



# LUND UNIVERSITY

## Roof top PV retrofitting: A rehabilitation assessment towards nearly zero energy buildings in remote off-grid vernacular settlements in Egypt

Dabaieh, Marwa; N. Makhlof, Nahla; M. Hosny, Omar

*Published in:*  
Solar Energy

*DOI:*  
[10.1016/j.solener.2015.11.005](https://doi.org/10.1016/j.solener.2015.11.005)

2016

[Link to publication](#)

### *Citation for published version (APA):*

Dabaieh, M., N. Makhlof, N., & M. Hosny, O. (2016). Roof top PV retrofitting: A rehabilitation assessment towards nearly zero energy buildings in remote off-grid vernacular settlements in Egypt. *Solar Energy*, 123(123), 160-173. <https://doi.org/10.1016/j.solener.2015.11.005>

*Total number of authors:*  
3

### **General rights**

Unless other specific re-use rights are stated the following general rights apply:  
Copyright and moral rights for the publications made accessible in the public portal are retained by the authors and/or other copyright owners and it is a condition of accessing publications that users recognise and abide by the legal requirements associated with these rights.

- Users may download and print one copy of any publication from the public portal for the purpose of private study or research.
- You may not further distribute the material or use it for any profit-making activity or commercial gain
- You may freely distribute the URL identifying the publication in the public portal

Read more about Creative commons licenses: <https://creativecommons.org/licenses/>

### **Take down policy**

If you believe that this document breaches copyright please contact us providing details, and we will remove access to the work immediately and investigate your claim.

LUND UNIVERSITY

PO Box 117  
221 00 Lund  
+46 46-222 00 00



# Roof top PV retrofitting: A rehabilitation assessment towards nearly zero energy buildings in remote off-grid vernacular settlements in Egypt

Marwa Dabaieh<sup>a,\*</sup>, Nahla N. Makhlouf<sup>b</sup>, Omar M. Hosny<sup>c</sup>

<sup>a</sup> Department of Architecture and Built Environment, LTH, Lund University, Sweden

<sup>b</sup> Department of Architecture, Faculty of Engineering, Cairo University, Egypt

<sup>c</sup> KarmSolar, Egypt

Received 20 June 2015; received in revised form 4 November 2015; accepted 8 November 2015

Available online 11 December 2015

Communicated by: Associate Editor Arturo Morales-Acevedo

## Abstract

Vernacular buildings in Egypt express a variety of passive low-tech approaches in design and construction to achieve human comfort and fulfil inhabitants' requirements. They have been devised to suit living in regions where local inhabitants had to invent various passive building strategies to live under severe local climatic conditions without depending on fossil fuels. This paper discusses a retrofitting approach for off-grid vernacular buildings in the Western Desert of Egypt. The study hypothesis argues that, when retrofitted and equipped with renewable energy solutions, vernacular structures can act as nearly zero energy buildings. A post occupancy evaluation was used as an assessment tool for two pilot projects that served as case studies. Results showed that combining vernacular passive strategies with affordable active renewables such as roof top solar panels results in a hybrid energy efficient retrofitting solution for deprived off-grid vernacular buildings. The intention is for the results to act as a basis for future retrofitting that would take into account the challenges and obstacles inherent in such work. This is an aim capable of contributing to a reduction of energy consumption that would also encourage retrofitting using renewable solutions for existing housing stock in Egypt.

© 2015 Elsevier Ltd. All rights reserved.

**Keywords:** Roof top PV; Vernacular retrofitting; nZEB; Energy poverty; Post occupancy evaluation

## 1. Introduction

Over a long period of trial and error, indigenous communities have succeeded in adapting their surrounding materials to the climatic context of their respective regions (Shokry, 2009). This has resulted in native buildings which express the culture and satisfy the social, physical and envi-

ronmental needs of the inhabitants (Oliver, 2006). Since the essential attribute of this inherited building wisdom is climate-specificity, vernacular buildings optimize the energy performance of buildings using local materials at low cost (Dabaieh, 2011; Zhai and Previtali, 2010). Under the pressure of current state-of-the-art technological interventions, such wisdom is gradually being neglected and

\* Corresponding author at: Solvegatan 24, Lund 22100, Sweden. Tel.: +46 73 878 17 15; fax: +46 46 222 72 72.  
E-mail address: [marwa.dabaieh@arkitektur.lth.se](mailto:marwa.dabaieh@arkitektur.lth.se) (M. Dabaieh).

overlooked within the vernacular settlements in Egypt's Western Desert (Dabaieh, 2011; Makhoul and Eid, 2013). In Egypt, while many contemporary architects do apply vernacular composition techniques, few are concerned with energy efficiency matters within their spectacular structures. An approach that adopts a natural energy strategy is considered quite limited and common architecture practices show little attention to the effective use of passive vernacular design strategies.

The challenge, in an age dominated by a high rate of fossil fuel dependent energy consumption, is how to achieve an ideal living environment while using the least amount of energy through conserving inherited passive strategies in vernacular buildings. The current trend is to seek out sustainable energy performance approaches to reduce energy consumption rates through retrofitting (Sibley and Sibley, 2013). This need for retrofitting comes as a result of the global building sector's consumption of over half of the total energy consumed worldwide (Dixon et al., 2014). Vernacular buildings are an untapped source of cost and energy savings in addition to offering the potential to reduce CO<sub>2</sub> emissions. Integrating energy renewable devices with the passive concepts of energy use embodied in vernacular building is one of the approaches currently being explored as a way of creating an energy efficient built environment (Weber and Yannas, 2013). Thus, this approach can act as a reflection of technological intervention on the level of the building fabric and service system that can contribute towards enhancing the energy efficiency of buildings (Guy and Farmer, 2001). Of course, the fact that advanced modern technologies are also capable of improving the performance of vernacular buildings, should not be dismissed (Ghaffarianhoseini et al., 2012). Nevertheless, it is vital to merge the lessons of passive techniques of vernacular building performance with those of advanced technologies.

In Egypt, tackling building retrofits and rehabilitation is currently crucial so as to meet the national targets for reducing energy consumption. The goal is to increase the percentage of renewable energy use from 11.6% to 20% of total energy consumed by consumers by 2020 (RCREEE, 2012). The recent global financial crisis, which has been accompanied by an energy crisis in Egypt, has lowered real estate valuations in the country. None of this, however, has been enough to shine a light on the need for the rehabilitation and retrofitting of the existing building stock. A considerable percentage of buildings in Egypt are in dire need of renovation and rehabilitation and, like the two cases investigated in this study, many settlements are still off the grid. There is huge potential in retrofitting vernacular buildings. The integration between low-tech vernacular passive building techniques and the high-tech renewable solutions results in a hybrid system that can easily make vernacular buildings meet nearly zero energy building (nZEB) standards. Adopting renewable interventions also offers a way to preserve the vernacular building tradition and local knowhow.

Improving energy efficiency and achieving a reduction in greenhouse gas emissions cannot be achieved unless serious

retrofit measures, guidelines and tariff policies are promoted by the government. If this were to happen, it would be a step towards achieving sustainable rehabilitation, which might result in a rehabilitated vernacular sector that goes beyond nZEB standards. In light of this possibility, this study will highlight a recent approach to retrofitting vernacular buildings using photovoltaic (PV) renewable solutions. The study sets three main objectives: to evaluate pilot vernacular retrofitting projects; to suggest solutions for low-impact and self-sufficient retrofitting for vernacular buildings; and to discuss potentials and drivers for PV retrofitting in Egypt. This paper will tackle this approach from the perspective of energy efficiency using Post Occupancy Evaluation (POE) surveys as an assessment tool. This study will also highlight obstacles liable to hinder the further rehabilitation and retrofitting of vernacular buildings in Egypt.

### *1.1. Energy efficient retrofitting for vernacular buildings: study background*

Solar and wind energy are today generally applicable solutions for providing one of the lowest cost options for supplying electricity in rural regions around the globe compared to providing connection to conventional electricity grids (Foster et al., 2010). Alternative energy supply can also contribute to economic and community development as they help create local jobs, and promote economic development with clean energy resources. Despite the positive benefits, there are still only very few cases of environmental and sustainable rehabilitation or retrofitting (Carrapiço and Neila-González, 2014), especially rehabilitation research projects covering vernacular conservation and adaptive re-use (Cabral et al., 2014). Previous studies have evaluated the benefits of passive energy efficient methods of vernacular buildings in hot climates (Givoni, 1992; Fathy, 1986) and the potential for such passive strategies to affect for example, energy use both for cooling during the summer and heating in the winter (Ryan, 2011). However, the literature focusing on the effect of combining passive vernacular strategies with high-tech renewable solutions is limited. One recent research study was conducted by Sibley and Sibley (2013). The study discusses a newly developed approach for the rehabilitation of vernacular Hammam buildings in Moroccan and North African cities using sensitive and non-intrusive solutions. This approach combines the attributes of vernacular heritage buildings with affordable high-tech solutions (e.g. small scale solar powered electric lighting). In the Middle East and North African regions there is not much focus on the integration of renewable energy solutions within existing vernacular settlements. Rehabilitation is mainly for touristic purposes: for example, the adaptive re-use of listed vernacular settlements in Gadames in Libya and Matmatta in Tunis. In light of such initiatives, Cabral (2007) suggests an approach to environmental assessment for retrofitted vernacular buildings already located in protected areas.

Over the past two decades, rehabilitation projects for vernacular settlements in the Western Desert of Egypt have focused on the preservation of building structure and character. Renewable energy solutions are still outside the focus of current research. In our literature review, we found neither in-depth studies on energy responsive designs nor their affect in reducing the symptoms of climate change, nor the integration of renewable solutions in vernacular buildings in Egypt. Moreover, the latest studies conducted by Attia (2012) and Petruccioli and Montalbano (2011) and the technical reports of the Siwa oasis rehabilitation by EQI Environmental-Quality International (2008), have not revealed any approaches using renewable applications. Despite the heavy investment in electrification by the Egyptian government, citizens in remote desert areas still lack electricity to meet their basic needs. The cost of utility power infrastructure is high, especially considering the small household electrical loads and the fact that many of the remote villages are located far from one other. Stand-alone solar energy systems can be cost-efficient and provide adequate levels of power for lighting, fans, refrigerators, TVs, and even for water pumps. Foster et al. (2010) argued that the need for power grows much faster for less developed nations than for those that are already industrialized. They also stated that PV projects in developing nations have provided positive changes in the lives of the rural people.

From our investigation of different initiatives, it has been apparent that there are only two notable retrofitting projects in Egypt. These two projects were for two villages in the Baharia and Siwa oases and were carried out between 2010 and 2014. The first project began in the village of El-Gara in the Siwa Oasis in December 2010 (New and Renewable Energy Authority-NREA, 2010). The provision of the PV units in El-Gara came as a part of the cooperative project “Solar Photovoltaic Rural Village Electrification” that was completed in collaboration with the Egyptian authorities, New & Renewable Energy Authority (NREA), Egyptian Environmental Affairs Agency (EEAA), Rural Electrification Authority (REA), the Matrouh Governorate, and the Italian Ministry for the Environment and Territory (New and Renewable Energy Authority-NREA, 2010). The project targeted four Egyptian rural communities and remote villages in desert areas, of which El-Gara was one (MEDREC, 2005), Fig. 1. The second initiative began in late 2012 in the village of El-Heiz in the Baharia Oasis. This was a community driven initiative, called the Tanweer El-Heiz Project, which was established by volunteers from the community club Rotaract Cairo. We selected both pilot projects as case studies for our research using POE to assess the efficiency of the PV systems in the two projects. To our knowledge there is no assessment or monitoring so far for the efficiency of the photovoltaic systems installed in both the two off-grid villages.

## 1.2. Introduction to the case studies

In this section we will provide a brief overview and background of the solar home system (SHS) provisions in the two case studies. They are both located in the Western Desert of Egypt and known for their distinctive earth vernacular architecture. This information is provided to help the reader understand the context and goals of each case study (see Figs. 1 & 2).

### 1.2.1. El-Gara village in the Siwa Oasis

The official name of the village is Qārrat ʿUm aṣ-Saḡīr (Makhlouf and Eid, 2013). It is located in the administrative province of the Siwa Oasis, in part of the Matrouh Governorate in the Western Desert of Egypt. It is the only inhabited settlement in the Qattara Depression (Information and Descison Support Centre, 2012; Vivian, 2007) because of its isolated nature, the village of El-Gara is one of the maintained distinctive vernacular desert settlements (Thomas, 2012). It is a tribal community of 512 inhabitants according to the 2012 census done by the Information & Decision Support Center of Matrouh Governorate (IDSC). El-Gara is located 120 km from the nearest inhabited community in the Siwa Oasis (Yousef, 2007; Vivian, 2007). Due to its remoteness, El-Gara is not connected to the Egyptian National Electricity Grid. Inhabitants depend on diesel-generator plants with a total capacity of 5180 KW/h (Information and Descison Support Centre, 2012). From site investigations, it appears that locals have an unstable eight hours per day of power provided to them, from 12 pm until 2 pm and from 6 pm until 12 am.

In December 2010, the provision of PV systems for all the 75 existing houses was accomplished (New and Renewable Energy Authority-NREA, 2010, 2011), among which, 14 were vernacular houses. PV systems were also installed on public buildings such as the school, the clinic, the local municipality building and the mosque. In addition, the project included 30 solar PV street lamps (New and Renewable Energy Authority-NREA, 2010, 2011).

### 1.2.2. El-Heiz village in the Baharia Oasis

El-Heiz is a village situated 40 km south of the Baharia Oasis in the Egyptian Western Desert. It lies 440 km southwest of Egypt’s Capital, Cairo, and is home to around 3300 people. It marks the border between the Giza governorate and the beginning of the New Valley. The village is divided into 17 settlements, each between 8 and 100 houses large. A total of around 550 households are scattered around a 14 km radius. Remote and scarcely populated, the community receives little governmental support and no developmental aid. The Hayazeya (People of El-Heiz) have adopted a rather primitive lifestyle mostly focused around agriculture. Despite their livelihood, they suffer greatly from a lack of basic resources, mainly continuous and reliable electrical power and access to clean water and medical care (Rotaract Cairo Royal, 2013).





Fig. 1. A cluster of vernacular buildings in El-Gara, Siwa Oasis, Egypt (upper photo) and El-Heiz, Baharia Oasis, Egypt (lower photo) after the provision of the PV units.



Fig. 2. A Google Earth image showing the location of both El-Gara village in the Siwa Oasis and El-Heiz village in the Baharia Oasis, Egypt.

The government has installed a single generator in most of these settlements, powered by diesel fuel. The government provides the village with diesel to run generators for three hours daily, which the village mostly use for water pumping to maintain their crops, since land cultivation is the only source of income in the village. They receive a ration of diesel every week that's supposedly enough to cover power generation from 8 pm to 11 pm, daily. However, due to issues such as mechanical failures and the shortage of diesel fuel in the Baharia Oasis, the arrival of rations is never guaranteed. Power from the generator is thought sufficient for home electrification as well as water pumping for irrigation, yet, in reality it is not enough for a decent livelihood. The lack of electricity has greatly affected the village and leaves its residents unable to satisfy basic conveniences, such as the ability to store perishable food in the refrigerator or to turn on a light bulb at night.

A group of volunteers initiated a project aiming to combat a few of the challenges facing the community and to hopefully overcome electrical power deficits in a sustainable manner. They managed to install SHSs that provide local residents access to electricity 24 h a day. The group also set up a trust fund for villagers, to ensure the proper maintenance and sustainability of these modern state-of-the-art installations. The team relies on grants and fundraising initiatives for the supply of goods for the project is divided into phases. Till now the project entailed the electrification of 31 households. The first phase of the project covered three hamlets of the village (Ein Gomaa, Ein Matarawi, Bir Ragab Said) with electricity through complete SHS (Rotaract Cairo Royal, 2013).

## 2. Methodology

The case study methodology adopted is structured into two main phases. The aim is to both obtain a reliable assessment of the inhabitants' satisfaction, and to confirm the adequacy of the rooftop PV system as a renewable energy source. We are also interested in better understanding the rooftop PV system's influence on overall building performance. These intentions were vital to developing a set of recommendations for further interventions and retrofitting standards for a more energy efficient and sustainable vernacular rehabilitation approach.

### 2.1. Phase one: The data collection phase

This phase comprises a literature study of relevant publications, project reports (local and foreign NGOs, and private investors), technical reports from local municipalities, and a field survey to collect data for the information that could not be obtained from published reports. The tools used for the field qualitative survey were mainly: structured open-ended interviews with municipal personnel and structured interviews; questionnaires with local villagers; photography documentation, video filming, field notes, voice recording, and site observations. The aim of

this phase was to collect all possible information for the case study chosen for assessment, which is essential for analyzing the projects and detecting the problems that will guide this study's recommendations. Three field trips were conducted between December 2012 and January 2015.

During these visits, 25 in-depth interviews were carried out with municipal and governmental institutions representatives. Additional interviews were conducted with NGOs, local authorities, and public investors. The interviews targeted information about project facts and figures, location, accessibility, sustainability, safety and security maintenance, monitoring of users' satisfaction, and running costs. Other than when questioning the NGOs, the interview topics in the meetings with the municipality and governmental institutions representatives focused on main issues such as: the reasons behind the initiation of the project, the project's sponsors and facilitators, the project's timeframe, the criteria for unit maintenance, and the installation process. We mainly employed face-to-face interviews. Both structured group interviews and individual questionnaire-directed interviews with 40 of the local villagers were also conducted. To ensure consistency in the local responses, a main respondent from each dwelling was selected, typically, this respondent was the house owner. In group interviews, all the inhabitants of the dwelling were involved to ensure that all views were recorded.

The survey covered: (1) the background of the interviewee (education, economic status, and lifestyle); (2) typology of the house; (3) changes in the lifestyle patterns of the inhabitants after the implementation of the domestic solar power project; (4) level of satisfaction and acceptance of the new intervention (environmental, quality of life, whether meeting their needs); (5) types of electric devices that the new intervention (PV units) managed to facilitate; (6) maintenance strategy and resident's understanding of how to deal with it. Manual transcriptions were made of all the interviews, questionnaire responses, documentary videos, and of the group discussions with the locals and NGO representatives. The outcome of the interviews was supported by our site observations, field notes, photographs, and other documents (e.g. the municipality technical reports). Although this study has attempted to provide in-depth insight into the efficiency of the PV system used and the users' satisfaction, it must be noted that due to the special nature of this remote community, the number of respondents was relatively small. Hence, the findings cannot be generalized and used as statistical data. However, the study does give an indication of how community energy surveys might be conducted in the future.

### 2.2. Phase two: Assessment and evaluation phase

This phase is based on the findings from phase one. A critical approach was adopted based on certain defined criteria, such as intervention methods, the efficiency of the methods, and users' satisfaction. Thus, the site survey



helped to design the criteria for evaluation and assessment. It was important to evaluate the intervention in order to set robust recommendations for further applications. The tool used in this phase was a designed Post Occupancy Evaluation (POE) questionnaire. The polar scale was used with the same sample of inhabitants that was interviewed in phase one, which reflected the results of the selected houses equipped with the PV system. The POE was meant to measure the local inhabitants' satisfaction/dissatisfaction with specific targeted PV features such as: functionality, flexibility of the system, maintenance accessibility, space occupied by the system devices, efficiency of the system, and the overall satisfaction expressed by locals. Results from the POE also provided suggestions for alterations in future rehabilitation and retrofitting projects. The questions in the designed POE are asked in relation to the provided PV service. During our preliminary POE test sample, we found that it was hard for locals to use the range scale for satisfaction and dissatisfaction. Accordingly, we simplified the scale to a simple 'satisfied' or 'not satisfied' to avoid confusion and to increase the accuracy of responses.

### 2.3. Characteristics of the dwellings and dwellers in the survey sample

The dwellings in El-Gara and El-Heiz are constructed from traditional materials available in the local environment in both the Baharia and Siwa Oases. These materials include primarily salt clay (*Karshief*), adobe, and palm tree wood. The dwellings were built around the late 18th and early 19th century, although no definite year of construction could be retrieved. The household types in the sample group are families with an average number of between 5 and 8 members. The dwellings are typically occupied by women during the day, on weekdays, and on weekends. In the evenings the dwellings are fully occupied (women, men, and children). Demographically, the average age of the respondents is between 22 and 70 years old and 25% of the survey samples were females.

## 3. Results and discussion for SHS efficiency assessment survey

Survey findings were gathered from interviews, group assessment discussions and the POE satisfaction questionnaire. The results of the questionnaire, Fig. 3, show that a total of 71% of the respondents in El-Gara were satisfied with the PV system functionality and 44% with the flexibility of the system; 85% of the respondents were satisfied with the required maintenance procedures of the system, and 86% were satisfied with the area that the PV cells occupied on their roofs. Eighty-seven percent of people were satisfied with the service in general, and all of the sample group was satisfied with the service compared to the previous situation. In El-Heiz 90% of the respondents were satisfied with the PV system functionality and 85% with the flexibility of the system; 90% of the respondents were

satisfied with the required maintenance procedures of the system, and 89% satisfied with the area that the PV cells occupied on their roofs. Ninety-seven percent of people surveyed, were satisfied with the service in general and all were satisfied compared to the previous situation.

The analysis of the interviews and discussion groups showed a total average of 78% of the sample group were satisfied and 22% had concerns of some kind or were neutral concerning the functionality and flexibility of the system. The most frequently cited positive factors were the permanent access to a secure source of electricity-day and night- which is not dependent on the public grid, connection to nature and the use of a clean renewable energy source rather than dependence on diesel. There was also satisfaction with the amount of space taken by the domestic (SHS) devices because each PV unit occupied only  $1 \times 1 \text{ m}^2$ . Regarding maintenance effort and cost, locals believed that this was affordable and adequate; however, sometimes they had to depend on outside technical support. The PV units were financially supported by the project but the locals had concerns whether they could afford to provide their new houses with a PV system given its high purchase price.

Nevertheless, minor shortcomings have been reported regarding the installed units, such as the limited capacity of the installed units (two panels per house). The capacity of two PV units installed on a single house is a maximum of 424 W at their peak. This is sufficient for only nine 18 W energy-efficient light bulbs, a 60 W TV set and an eight W radio (New and Renewable Energy Authority-NREA, 2006). Because of the simple lifestyle in the village, high energy consuming machines are not needed on a frequent basis. Refrigerators, washing machines, blenders, and irons are used only occasionally. Nonetheless, some locals said that they still cannot do without the diesel powered generators. The generators remain a backup system when the PV units produce insufficient power, for example on some long winter nights and on cloudy, rainy days. Additionally, many of the dwellers still lack the understanding of how to carry out proper care of the system, which requires regular maintenance to remain efficient. Yet, considerable lifestyle changes have been observed and mentioned by locals as a result of the 24 h of power provided to dwellers, as compared to their previous state of a limited 6–8 h per day. This change has resulted in the day and night availability of radio and TV sets, which consequently allow for longer family gatherings. The additional power makes it possible to receive guests at night, and makes it easier to get to dawn prayers in the mosque.

Despite the shortcomings discussed above, the findings from this study allow us to summarize that energy retrofitting and the rehabilitation of vernacular off-grid dwellings is effective in reducing short and long term energy use. More ideas for retrofitting, like using proper glazing, window shading, adding an exterior layer of plastering with reeds and clay for east and west facades to reduce direct heat gain in summer time, and proper sealing for windows

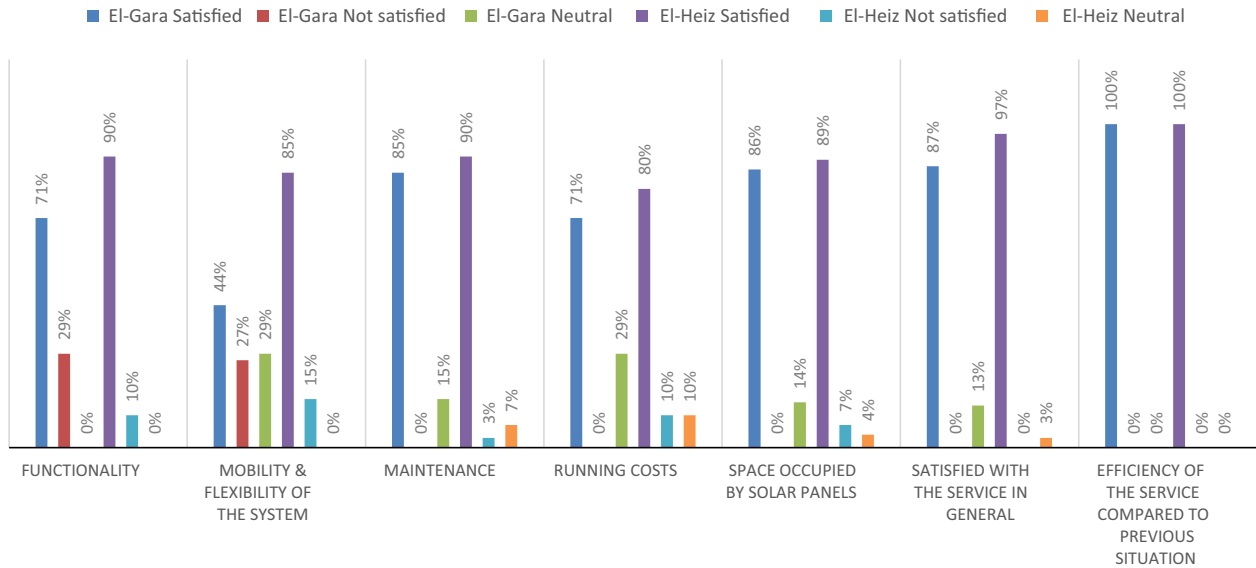

Fig. 3. Respondents' satisfaction questionnaire survey results in El-Gara villages and El-Heiz, Egypt.

and doors to reduce infiltration, can improve the indoor thermal comfort levels and reduce dependency on fans in the summer time.

#### 4. SHS technical installations and their socioeconomic impact

The cost of the installed SHS is 15 500 EGP (1800 euro). In order to insure the project's economic sustainability and to provide a legal continuation for the PV installation process contracts need to be signed by a varying number of stakeholders. In the case of El-Heiz, contracts were signed by both Rotaract Cairo (representing the project initiators) and El-Heiz home owners. In the case of El-Gara, contracts were signed by the local municipality in El-Gara (representing the official project coordinator) and El-Gara home owners. Contracts included detailed components of the SHS unit, rules for penalty in case of selling the unit and back-up criteria for system collapse. The contract states regulations for back-up criteria that relies on the system provider in some situations, on home owners, or the community trust fund, as in the case of El-Heiz.

The two cases differ in their management system for maintenance and locals' satisfaction with the cost of batteries for running the system as well as maintenance costs. In El-Heiz there is a system generated by the local community to manage the cost of running the PV systems. This ensures financial sustainability and has been working as planned. Villagers form a local trust fund to ensure proper maintenance and sustainability. Locals elected one person from the village to manage a fund to which each home owner pays 1 LE per day – 30 LE per month – (equivalent to 3.5 euros). The fund is dedicated to replacing the batteries whenever needed and comes out to an annual contribution

of around 360 EGP (equivalent to 40 euros) per household per year, which will suffice for the replacement of the batteries every 3–4 years. Smaller maintenance and replacement costs can be carried out by individual households. In the case of El-Gara locals were left to manage this issue by themselves, which threatens the sustainability of the project in the future. Generally, the regular cleaning of PV cells is an easy process and can be performed by any of the inhabitants of the house. This should be carried out either before sunrise or after sunset, 2–3 times a week. Our field survey revealed that the monthly maintenance check is frequently carried out in the two case studies and was relatively efficient on the level of technical damage or deficiencies.

Even though the PV system is considered an expensive energy (to provide and install), it brings many benefits to remote villages. It provides an off-grid sustainable energy solution for the electricity shortage problem. The system's cost of maintenance (in the long term) is also limited compared to its average life span of 25 years. It provides a clean source of energy that is neither noisy nor pollutes the environment, especially when compared to the conventional diesel generators. The system can also be integrated with other conventional power provision systems when needed. Nevertheless, such a system needs proper and safe roof construction, which is not always provided in vernacular buildings. The average household has six individuals, of which 50% are women, and 1/3 are children. Therefore, the social impact is mainly on the women and children who benefit from an improved quality of life and livelihood. Men were mainly involved in the maintenance and installation of the system which opens up new job opportunities. In addition to securing the household energy, it has an indirect effect on agriculture, the main source of rural livelihoods.



## 5. Energy consumption calculation before and after using PV

In the El-Heiz project, each SHS was designed to supply each household with around 2.2 kW h per day, assuming a load of six energy efficient light bulbs, three fans, one small refrigerator, and a TV/radio. Each household will therefore need: 420 W PV panels, a battery capacity of 240 A h, a small 1000 W inverter, a battery charge controller, a mounting structure, wiring, safety devices, a Solid State Relay, and other necessary appliances (see Tables 1 & 2). Connections between system components are shown in Fig. 4. For El-Gara, the PV system used was implemented to meet the total load demand of about 500 W h per day. The PV size is estimated to be 300 W h per house with 2 125 A h/C10, 12 V series batteries and a 10 A charge regulator; all connected to the house, (MEDREC, 2005) (see Tables 1 & 2). According to Marszal et al., there are no standardized calculation procedures for zero energy buildings (ZEB), and most of the calculations that do exist are just individual approaches in each particular ZEB case (Marszal et al., 2011). Based on this, we estimated a calculation for the energy consumed by electrical appliances in the surveyed houses shown in Table 2. The houses are an average of 90 square meters. The below equation is used to calculate the total energy consumption, (Wattage  $\times$  Hours Used Per Day)  $\div$  1000 = Daily Kilowatt-hour (kW h) consumption. The result of the calculations shows that the average energy consumption of homes in El-Gara before using the PV system was 243.1 kW h/m<sup>2</sup>/year, and after using the PV system, is 65 kW h/m<sup>2</sup>/year.

The common definition of nearly Zero Energy Building, or nZEB, is a building that exhibits a high energy performance. These buildings require very little energy, using mainly renewable sources produced on-site or nearby. Based on the above calculations, vernacular buildings in the two case studies show a high energy performance due to the fact that residents live simply (requiring few electrical appliances) and cooling and heating is mainly dependant on passive methods. The passive energy efficient strategies found in the sample case studies will be explained in Section 5.1.

### 5.1. Common vernacular passive strategies supporting PV retrofitting

The vernacular Karshief and adobe houses in El-Gara and El-Heiz act as a model for the thermal adaptation of buildings to the surrounding climate. This is reflected by means of passive design through the building orientation, window-to-wall ratio, building envelop, thermal mass and the choice of the building materials. This will be further discussed in detail below.

#### 5.1.1. Site orientation

Both village layouts are oriented to local weather patterns and climate in addition to wind speed and direction. As vernacular knowledge considers the sun's path for winter heating and summer cooling, settlements were built with narrow streets and small buildings that respond to climatic needs. The use of urban space provides shade and lessens the exposure of walls to direct sun, which ultimately reduces the internal heat gain in buildings. In addition, this street structure offers protection from strong sandy winds. Fig. 5 shows the path of the sun, the direction of both sandy winds and pleasant winds in El-Gara village.

#### 5.1.2. Building orientation

The orientation of the building primarily responds to the sun. The buildings were built somewhat longitudinally, in a north–south direction. As discussed by Givoni (1994), the more longitudinal the building, the greater the surface area subjected to external weather (the sun in the summer or wind in the winter). For this reason, the buildings are a ratio between 1:1 and 1:2. Some buildings are oriented

Table 2  
Capacity of PV installation in both case studies.

Appliances	El-Gara village	El-Heiz village
PV panels	300 Wp/house	420 Wp/house
Battery	2 * 125 A h/C10, 12 V	240 A h
Inverter	500 W	1000 W
Charge regulator	10 A	10 A
Total capacity	1 kW h/day	2.2 kW h/day

Table 1  
Energy consumption per average electric appliance per house powered by PV or diesel in both the case studies.

Device type	Energy consumption (W)	Average number of devices per house unit	Average use per day	PV or diesel operated
CFL lamps (60 watt equivalent)	11	5/6	10 h/day	PV
11" TV (CRT) set	65	1	4.5 h/day	PV
Radio set	8	1	1.5 h/day	PV
Celling or land set fan	40	2	2 h/day	PV
Blender (if any)	300	1	10 min/day	PV/Diesel
8 feet fridge (if any)	100	1	24 h/day	PV/Diesel
Iron (if any)	1100	1	30 min/week	PV/Diesel
Satellite receiver (if any)	28	1	4.5 h/day	PV

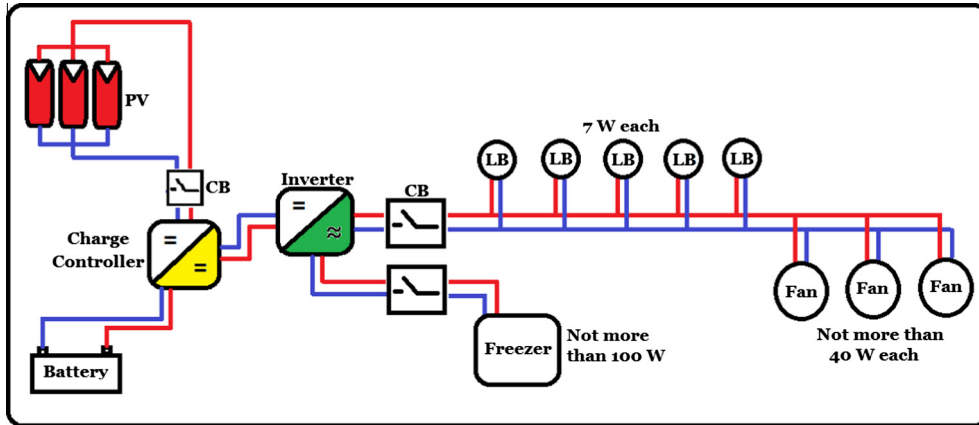

Fig. 4. Unit components and their technical connections from PV panels to different home appliances developed by authors based on site survey at El-Heiz, Egypt.

close to 15 degrees to the west, which minimizes heat gain from the sun in the summer and maximizes the amount of sun that heats the walls in the winter. Cooling is more of a priority than warming, so the buildings are mainly oriented towards the north or North West in order to take advantage of the prevailing cool breezes in summer Fig. 6. The main facades and openings are oriented towards the north or south.

5.1.3. Window to wall ration (WWR)

According to the Egyptian code of Energy Efficiency in Residential buildings in 2008, WWR is recommended to be within a range between 10 and 30, with specific various shading coefficients for each ratio (Efficiency code for Residential Building, 2008). However, in the case studies the ratio is less than 5 to minimize the glare in summer and to reduce heat gain from window openings. Generally, the glazing is not appropriate or does not exist. The window opening is often closed by a wooden mesh frame, which helps with indoor ventilation and at the same time reduces direct sun rays. Cotton pillows are also commonly used to close window openings when necessary, especially during sandy winter storms.

5.1.4. Building envelope

Siwa and Baharia are hot zones in the arid Western Desert. Wall thickness varies from a south to north façade orientation that responds to the local climate. The use of light-colored clay also helps reduce direct heat gain from sun rays. Since the indoor space is compact relative to the surface area of the external envelope, according to Givoni (1994), the heat gained from high outdoor temperatures is limited.

5.1.5. Thermal mass

Thick Karshief walls have a high thermal mass, helping reduce peak building space temperatures with exposed dense materials that absorb heat during the hottest days, and slowly release it during cooler periods. The wall thickness ranges from 80 cm to 50 cm which is one of the main strategies for passive cooling and heating see Table 3. As Karshief’s material qualities permit the walls to accumulate heat at sunny hours and maintain a steady temperature despite a strong variation in temperature between day and night. In this way, the indoor temperature can be maintained below the outdoor temperature, which is especially helpful during the day and in the summer.

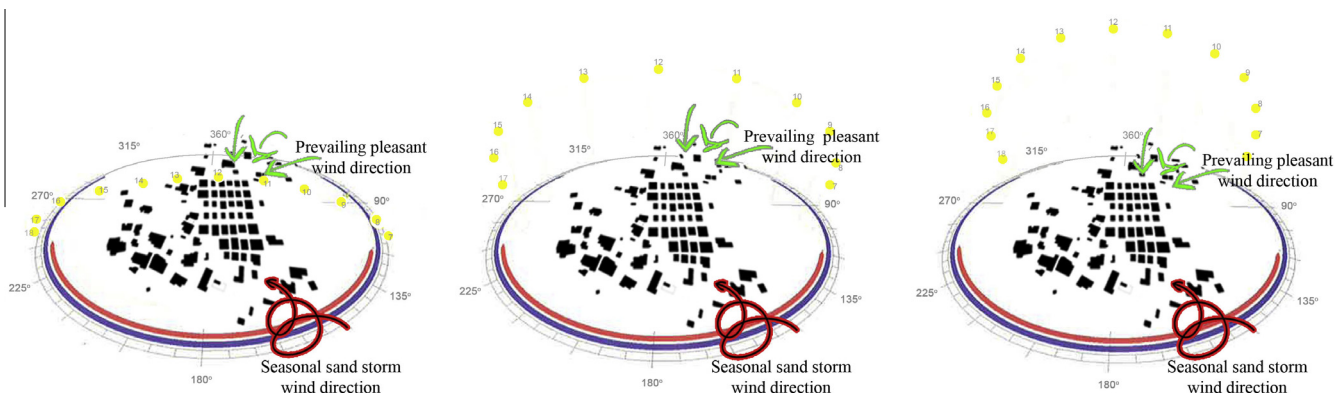

Fig. 5. The orientation of El-Gara settlement, Egypt in respect to the sun maximizes winter heat, while the streets are aligned with the direction of the prevailing pleasant wind for summer cooling.

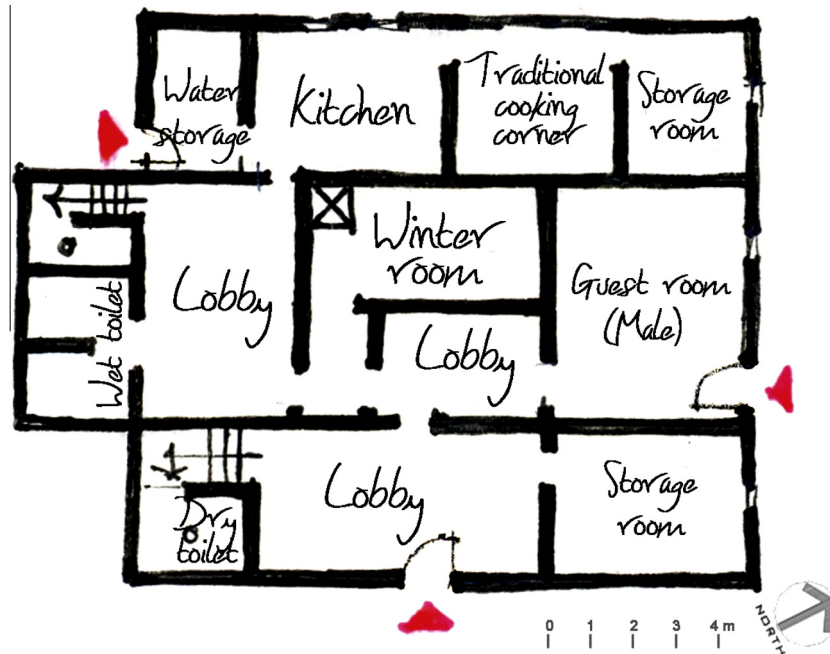

Fig. 6. A sketch of a ground floor plan for a sample house in El-Gara village, Egypt showing the house design and orientation of the opening.

#### 5.1.6. Natural ventilation

Since warm air with a low density rises, small enclosures inside the building cool the building envelope through stack ventilation by drawing cooler air from window openings facing low north prevailing winds, while carrying heat away through openings in the top of the space. The air moves with a rate dependent on the vertical distance between the inlets and outlets as well as the size and the difference in temperature inside and outside, divided by the height of the room. For winter heating, one room, oriented to the south is called the winter room and is heated by convection. It is an interior space built with a high mass and no openings other than the air vent for a small built-in fire place.

In addition to passive strategies applied in vernacular houses, using Karshief as a local building material as shown in Table 3 has a low embodied energy in its life cycle from building construction till demolition (cradle to grave) which has a direct impact in reducing CO<sub>2</sub> emissions.

### 6. Towards energy efficient and nZEB retrofitting for vernacular buildings

Generally, energy retrofitting has the potential to deliver several benefits. Most importantly, it provides secure permanent energy for off-grid areas; however, there are also

several positive health outcomes and social and economic benefits to using the technology. To build on what has been achieved so far, there is a drive to enact new laws to promote energy retrofits. If most of the currently energy-inefficient buildings in Egypt are still standing in 2050, the energy sector would be in serious trouble. We can summarize that the array of benefits and impacts of retrofitting extends beyond tangible and practical benefits because they can also deliver intangible benefits in respect to social cohesion and sense of local pride. These benefits fall into four main categories:

1. Environmental benefits: generally, reduction in CO<sub>2</sub> emissions and other pollutants generated by fossil fuels will have a direct impact on local climate. The gradual shift towards partial reliance on renewable energy sources leads to lower global impacts, which in turn supports a healthier built environment on a wider scale. The need for local residents to commute to larger cities in their oases to purchase diesel for their generators will be almost eliminated, which will decrease transportation expenditures and the use of fossil fuels. According to the case studies' project reports, an environmental impact assessment study was carried out stating that for each retrofitted dwelling, fuel saving can reach to 29.7 T.O.E. per year and CO<sub>2</sub> emission prevention can reach up

Table 3  
Karshief material properties based on a lab test for sample material.

Material	Density (kg/m <sup>3</sup> )	Thermal conductivity λ-value (W/m °C)	Thermal storage capacity (W h/kg °C)	Heat transfer time lag (250 mm thickness) (h)	Embodied energy (MJ/m <sup>3</sup> )	Global warming potential (kg CO <sub>2</sub> /m <sup>3</sup> )
Karshief	2185–2400	1.65–2.35	0.23–0.27	7.75	1121.5	32

- to 0.96 T per year in the case of El-Gara village (MEDREC, 2005) 49.5 T.O.E./y and to 1.6 T/y in El-Heiz (Hosney and Kenawy, 2013).
2. Energy system benefits: sustainable rehabilitation and energy efficient retrofitting will reduce what is known as fuel poverty. SHS installations provide access to electricity 24 h a day instead of the current situation in the discussed case studies, which is not even sustainable when local diesel generators break down. Retrofitting reduces energy demands, which in turn ensures energy security. SHS installations are a move towards energy efficiency that could contribute to the reduction of energy loads that are consumed through retrofitted vernacular buildings.
  3. Societal and health benefits: SHS has indirect health benefit dimensions in that it provides inhabitants with adequate thermal comfort. Retrofitting reduces levels of overheating during the summer and under-heating during the winter seasons. This is reflected in a household's level of productivity, which is known to be affected by thermal discomfort (Petruccioli and Montalbano, 2011; Lan et al., 2010). In addition, the availability of electricity will make it possible to store perishable foods in small refrigerators, therefore improving local health through food security and nutritional conditions. Young residents will be able to study at night (after completing their daytime farming chores) due to the availability of electricity, which will allow for an improved level of education among residents. Other social benefits include the engagement of local residents in SHS maintenance, which increases their sense of belonging and attachment to place. Residents are trained to install, operate, and maintain all aspects of the solar energy installations, solar panel assembly facilities, and battery manufacturer's facilities. The general quality of life will improve as locals are able to use light bulbs, fans, televisions, computers and all other electrically-operated tools.
  4. Economic benefits: for individual households the reduced spending on energy utilities leads to increased expenditure on other services, which in return leads to improvement in the quality of life and access to better facilities. Also SHS creates new types of job opportunities through training villagers to install, operate, and maintain household solar installations. SHS has indirect economic impacts. Villagers who will be in charge of the maintenance and management of trust fund will be able to promote their village as a model green village and host tourists interested in an eco-friendly life style in vernacular settlements. Thus, applying for other funds in order to expand the project to neighboring communities.

## 7. Retrofitting barriers and challenges

To reinforce the importance of retrofitting, it is not only important to evaluate the ongoing project discussed in this

study, but also to work to eliminate the barriers and obstacles capable of obstructing the sustainable retrofitting and rehabilitation of today's domestic building stock. In Fig. 7, we tried to summarize and draw attention to some of the barriers and challenges currently hindering retrofitting projects in Egypt. It is essential that the government take part in designing an overall rehabilitation strategy rather than restricting its backing to individual civic initiatives. Actions to address these barriers are needed if the aim is, first and foremost, to reduce energy consumption and provide basic energy needs to off-grid settlements. Measures should be taken in addition to the formulation of new policies and regulations that would target a particular building sector. We should learn from the experiences of neighboring Tunisia, Morocco and Algeria (Allal, 2004) and tailor a policy response to Egypt's specific barriers. The policies should not be restricted to a particular building sector but should be a mix that encompasses a range of measures to collectively address all building categories, ownership profiles, and tenures.

One of the downfalls of PV systems is their long term efficiency. This is because their performance is affected by dust and dust storms (which are common in the Egyptian desert). It has been proved by Román and his research colleagues that desert dust causes a decrease in the amount of direct sunlight, whereby UV irradiance can reach up to 55% (Román et al., 2013). Recent studies have discussed the impact of dust on PV performance and the linear relationship between the thickness of the layer of dust and the loss of productivity (Klugmann-Radziemska, 2015). Another study showed that dust storms can fracture the PV panel, which reduces its life span and had high impacts on how effective the PV surfaces are in collecting energy (Kazem et al., 2014). Regular manual or mechanical cleaning is highly recommended to remove fine dust, pollution, and sand particles, increasing the life span of the PV system and reducing the gradual decrease of its efficiency (Klugmann-Radziemska, 2015). It is recommended to model local desert dust events before installing PV systems (Bilbao et al., 2015).

### 7.1. Recommendations for further retrofitting using renewables

We have attempted in this section to put forward ideas to overcome the barriers we outlined in Fig. 7 for rehabilitation and intervention processes that also take into account economic factors and feasibility. We hope that this study will contribute towards encouraging rehabilitation and retrofitting projects with a view to promoting a more satisfactory measure of modern life standards. This study may lead to resolving another problem, which is the abandonment and demolition of vernacular settlements due to their lack of essential modern facilities. As Rapf and his research colleagues recommend, renovation and retrofitting buildings to reach a level of high energy performance could be the most effective investment a



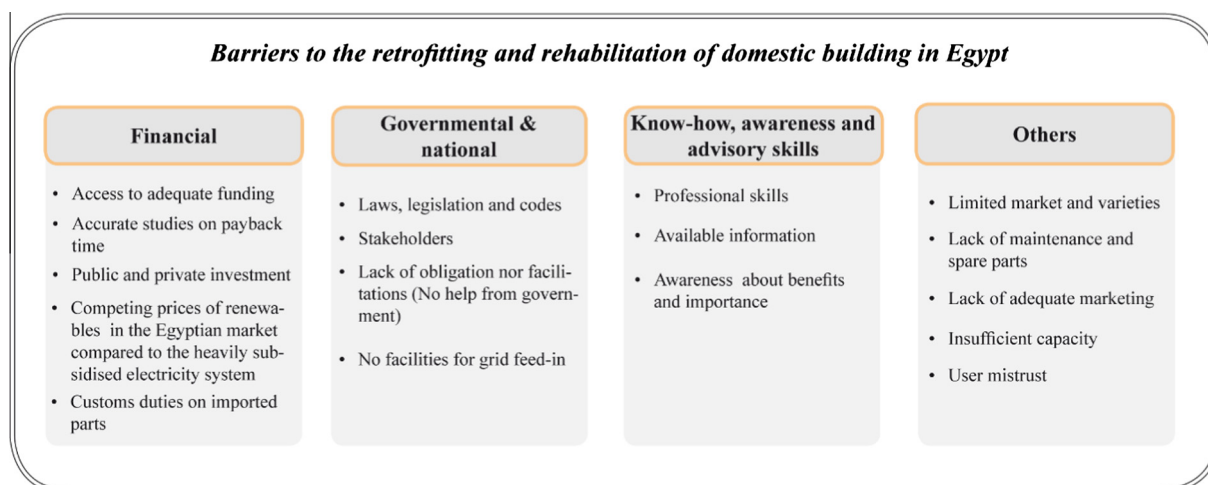

Fig. 7. Overview of some constraints in building retrofitting in Egypt. Developed after Rapf et al. (2013).

nation can make. They added that such an investment programme would create job opportunities, improve the quality of life and, most importantly, mitigate climate change hazards and secure permanent energy sources (Rapf et al., 2013).

Our main recommendations are as follows:

- Architects and designers have to play a more active role in increasing awareness of the importance of renovating existing vernacular settlements towards energy efficiency because waiting for better laws exposes vernacular buildings to more risks.
- Attracting finance from large institutional investors and NGOs for retrofitting, as is the case in this study, is one solution. This would require either public or private energy efficiency project aggregators, even when there are no clear regulations. Furthermore, more cross disciplinary approaches are needed to be able to meet such challenges.
- Tariffs and taxes should be reduced on renewable energy sources. Feed-in tariffs, the provision of renewable energy incentives, and even small grants are some of the solutions for promoting renewables.
- The development of mandatory codes and standards must begin.

## 8. Conclusion

This paper highlights an example of retrofitting for off-grid vernacular buildings. It aims to demonstrate the efficiency of vernacular passive elements when combined with an affordable high-tech solution – PV systems – resulting in a hybrid system that is user friendly, energy efficient and, most important, sensitive to vernacular buildings. From this research it is deduced that providing funding for retrofitting can be seen as of strategic national importance in

regard to reducing national energy consumption as outlined in the national energy agenda target of 20% reduction in non-renewable energy consumption by 2020. Renewables reduce the need to import fuel and lower the negative environmental impacts of fossil fuels. The provision of renewables opens the way to improved sustainable livelihoods. Consequently, models can be designed for a sustainable operation of hybrid systems that would guarantee overcoming the minor deficiencies in the economic life span of a renewable system. This proves that fulfilling contemporary needs in remote areas can be achieved by integrating highly advanced techniques with the local basic lifestyle. From our investigations, the high price often involved in importing spare parts from abroad would constitute a technical and financial burden for locals in remote vernacular towns and villages, unless such technologies could be manufactured locally. The scale of the energy saving impact of a single building reveals promising results if applied on a wider scale as a national policy.

Together with research on the life cycle cost of renewable systems in Egypt, further deep research is needed to monitor energy efficiency and assess life cycles. We believe that taking appropriate measures to remove regulatory as well as non-regulatory barriers to energy efficiency is a mandatory task. This approach will also help to sustain a local vernacular building practice which has proved to be resilient for many centuries. Further application of this approach will help reduce the rate of demolition and vandalism of historical vernacular settlements. If such hybrid energy systems are widely installed in old buildings, the regional characteristics of such settlements will still be kept and the unique environmental assets of the vernacular buildings will be preserved. Finally, encouraging deep renovation through clear legislation and innovative financing mechanisms would help reduce the consumption of fossil fuels required for building. This offers a body of evidence that will, we hope, help to inform future studies and retro-

fitting projects that work to achieve the national target of increasing the percentage of renewable energy used in the Egyptian housing stock.

### Acknowledgements

The authors would like to thank all the respondents who participated in our research survey for their time and the valuable information they provided. We would also like to acknowledge the Axel and Margaret Ax:son Johnson Foundation.

### References

- Allal, H.B.J. (Ed.), 2004. Renewable Energy Directory: A listing of Stakeholders in the MEDREC Countries, MEDREC. <<http://www.medrec.org/en/download/DATABASE2004.pdf>> (last retrieved: 4.12.13).
- Attia, D.N., 2012. Building Techniques as a Base for the Development of the Contextual Architecture (with a Special Reference to Siwa Oasis), PhD Dissertation, Cairo University.
- Bilbao, J., Román, R., Yousif, C., Mateos, D., De Miguel, A., 2015. UV and global irradiance measurements and analysis during the Marsaxlokk (Malta) campaign. *Adv. Sci. Res.* 12, 147–155.
- Cabral, M.I., 2007. Certifying a sustainable reconstruction of vernacular architecture in Peneda-Gerês National Park. *Proceedings of SB07: Materials and Practices*. IOS Press, pp. 1088–1095.
- Cabral, I., Machado, G., Coelho, A., 2014. Assessing energetic self-sufficiency and low environmental impact in Pontes, Portugal. In: Correia, Carlos, Rocha (Eds.), *Vernacular Heritage and Earthen Architecture: Contributions for Sustainable Development*. Taylor & Francis Group, London, pp. 593–598.
- Carrapiço, I.C., Neila-González, J., 2014. Study for the rehabilitation of vernacular architecture with sustainable criteria. In: Correia, Carlos, Rocha (Eds.), *Vernacular Heritage and Earthen Architecture: Contributions for Sustainable Development*. Taylor & Francis Group, London, pp. 581–586.
- Dabaieh, M., 2011. A Future for the Past of Desert Vernacular Architecture: Testing a Novel Conservation Model and Applied Methodology in the Town of Balat in Egypt, Media-Tryck, Lund, Sweden.
- Dixon, T.J., Eames, M., Lannon, S., Hunt, M. (Eds.), 2014. *Urban Retrofitting for Sustainability: Mapping the Transition to 2050*. Energy Efficiency code for Residential Building, 2008. Ministry of Housing, Housing and Building Research Centre-HBRC, Egypt.
- EQI Environmental-Quality International, 2008. The Development of Qara Oasis (Technical Report).
- Fathy, H., 1986. *Natural Energy and Vernacular Architecture: Principles and Examples with Reference to Hot Arid Climates*. Published for United Nations University by the University of Chicago Press, Chicago.
- Foster, R., Ghassemi, M., Cota, A., 2010. *Solar Energy: Renewable Energy and the Environment*. CRC Press, Boca Raton.
- Ghaffarianhoseini, A., Ghaffarianhoseini, A., Makaremi, N., Ghaffarianhoseini, M., 2012. The concept of Zero Energy Intelligent Buildings (ZEIB): a review of sustainable development for future cities. *Br. J. Environ. Clim. Change* 2 (4), 339–367.
- Givoni, B., 1992. Comfort, climate analysis and building design guidelines. *Energy Build.* 18 (1), 11–23.
- Givoni, B., 1994. *Passive Low Energy Cooling of Buildings*. John Wiley & Sons.
- Guy, S., Farmer, G., 2001. Reinterpreting sustainable architecture: the place of technology. *J. Archit. Educ.* (February), 140–148.
- Hosney, O., Kenawy, L., 2013. Tanweer El-Heiz, Rural Solar Electrification Project. Rotaract Club of Cairo Royal, Technical Report Cairo.
- Information & Decision Support Centre (Cabinete of Matrouh Governorate) – IDSC, 2012. Qârat Um-Aşaghier, Marsa Matrouh, Egypt.
- Kazem, A.A., Chaichan, M.T., Kazem, H.A., 2014. Dust effect on photovoltaic utilization in Iraq: review article. *Renew. Sust. Energy Rev.* 37, 734–749.
- Klugmann-Radziemska, E., 2015. Degradation of electrical performance of a crystalline photovoltaic module due to dust deposition in northern Poland. *Renew. Energy* 78, 418–426.
- Lan, L., Lian, Z., Pan, L., 2010. The effects of air temperature on office workers well-being, workload and productivity-evaluated with subjective ratings. *Appl. Ergon.* 42 (1), 29–36.
- Makhlouf, N.N., Eid, Y.Y., 2013. Towards an integrated neo-vernacular living environment: physical and socio-cultural aspects. In: *Democratic Transitions and Sustainable Communities: Overcoming Challenges through innovative practical solutions*. SB13 Cairo, Cairo, Egypt, pp. 238–250.
- Marszal, A.J., Heiselberg, P., Bourrelle, J.S., Musall, E., Voss, K., Sartori, I., Napolitano, A., 2011. Zero energy building – a review of definitions and calculation methodologies. *Energy Build.* 43 (4), 971–979.
- Mediterranean Renewable Energy Centre (MEDREC), 2005. Solar Photovoltaic Rural Village Electrification (Shs & Health Centers). <[http://www.medrec.org/en/download/EGYPT\\_SolarPhotovoltaicRuralVillageElectrification\\_Egitto\\_pdf](http://www.medrec.org/en/download/EGYPT_SolarPhotovoltaicRuralVillageElectrification_Egitto_pdf)> (last retrieved: 4.12.13).
- New & Renewable Energy Authority-NREA, 2006. Ministry of Electricity & Energy New & Renewable Energy Authority (NREA) Annual Report, 2006.
- New & Renewable Energy Authority-NREA, 2010. Ministry of Electricity & Energy New & Renewable Energy Authority (NREA) Annual Report 2009/2010, Cairo, Egypt. <<http://www.nrea.gov.eg/annual-report/annual2010En.pdf>> (last retrieved 16.3.13).
- New & Renewable Energy Authority-NREA, 2011. Ministry of Electricity & Energy New & Renewable Energy Authority (NREA) Annual Report 2010/2011, Cairo, Egypt. <[http://www.nrea.gov.eg/annual-report/Annual\\_Report\\_English\\_2010-2011.pdf](http://www.nrea.gov.eg/annual-report/Annual_Report_English_2010-2011.pdf)> (last retrieved 16.3.13).
- Oliver, P., 2006. *Built Meet Needs: Cultural Issues in Vernacular Architecture*. Architectural Press.
- Petruccioli, A., Montalbano, C. (Eds.), 2011. Siwa Oasis: Actions for a Sustainable Development, DICAR, Bari. <<http://architettura.poliba.it>> (last retrieved 28.4.13).
- Rapf, O., Faber, M., Nolte, I., 2013. A Guide to Development Strategies for Building Energy Renovation. Buildings Performance Institute Europe (BPIE), Project Lead, Brussels, Belgium.
- Regional Centre for Renewable Energy and Energy Efficiency (RCREEE), 2012. Renewable Energy Country Profile. <[http://www.rcreee.org/sites/default/files/rcreee\\_countryprofile\\_re\\_egypt\\_en\\_2012.pdf](http://www.rcreee.org/sites/default/files/rcreee_countryprofile_re_egypt_en_2012.pdf)> (last retrieved: 28.3.14).
- Román, R., Antón, M., Valenzuela, A., Gil, J.E., Lymani, H., de Miguel, A., Olmo, F.J., Bilbao, J., Alados-Arboledas, L., 2013. Evaluation of the desert dust effects on global, direct and diffuse spectral ultraviolet irradiance. *Tellus B* 65, 19578. <http://dx.doi.org/10.3402/tellusb.v65i0.19578>.
- Rotaract Cairo Royal, 2013. 2012/13 Africa's Rotaract Outstanding Project Award by Rotary International. ROTARACT DISTRICT 2450, p. 2. <[http://www.rotaractcyprus.org/wp-content/uploads/2013/08/RD2450\\_APRIL\\_NEWS1.pdf](http://www.rotaractcyprus.org/wp-content/uploads/2013/08/RD2450_APRIL_NEWS1.pdf)> (last retrieved: 10.1.14).
- Ryan, C., 2011. *Traditional Construction for a Sustainable*. Taylor & Francis, Hoboken.
- Shokry, H.M., 2009. A Vernacular Approach to Re-Shaping the Built Environment in Arid-Zones, (April), pp. 15–18.
- Sibley, M., Sibley, M., 2013. Hybrid green technologies for retrofitting heritage buildings in north african medinas: combining vernacular and

- high-tech solutions for an innovative solar powered lighting system for Hammam buildings. *Energy Proc.* 42, 718–725.
- Thomas, G., 2012. Tour Guide: Siwa Natural Reserve and Shali the Old Town (Arabic Version), Siwa, Matrouh.
- Vivian, C., 2007. *The Western Desert of Egypt: An Explorer's Handbook*. American University in Cairo Press, Cairo, Egypt.
- Weber, W., Yannas, S., 2013. *Lessons from Vernacular Architecture*. Routledge.
- Yousef, S. A., 2007. The Popular Traditions of Siwa. In: National Center for Theater, Musik and Folk Arts, ed., Ministry of Culture in Collaboration with Matrouh Governorate, Cairo. (Arabic).
- Zhai, Z. (John), Previtali, J.M., 2010. Ancient vernacular architecture: characteristics categorization and energy performance evaluation. *Energy Build.* 42 (3), 357–365.