



# LUND UNIVERSITY

## Male Subfertility and Prostate Cancer Risk: Epidemiological and Genetic Studies

Ruhayel, Yasir

2012

[Link to publication](#)

*Citation for published version (APA):*

Ruhayel, Y. (2012). *Male Subfertility and Prostate Cancer Risk: Epidemiological and Genetic Studies*. [Doctoral Thesis (compilation), Molecular genetic reproductive medicine, Malmö]. Lund University: Faculty of Medicine.

*Total number of authors:*

1

### General rights

Unless other specific re-use rights are stated the following general rights apply:

Copyright and moral rights for the publications made accessible in the public portal are retained by the authors and/or other copyright owners and it is a condition of accessing publications that users recognise and abide by the legal requirements associated with these rights.

- Users may download and print one copy of any publication from the public portal for the purpose of private study or research.
- You may not further distribute the material or use it for any profit-making activity or commercial gain
- You may freely distribute the URL identifying the publication in the public portal

Read more about Creative commons licenses: <https://creativecommons.org/licenses/>

### Take down policy

If you believe that this document breaches copyright please contact us providing details, and we will remove access to the work immediately and investigate your claim.

LUND UNIVERSITY

PO Box 117  
221 00 Lund  
+46 46-222 00 00

Department of Clinical Sciences Malmö  
Molecular and Genetic Reproductive Medicine  
Lund University

# MALE SUBFERTILITY AND PROSTATE CANCER RISK

Epidemiological and Genetic Studies

Yasir Ruhayel



LUND UNIVERSITY  
Faculty of Medicine

## **Doctoral Dissertation**

to be publicly defended on Friday the 27<sup>th</sup> of January, 2012 at 09:00,  
in Jubileumsaulan, Entrance 59, Skåne University Hospital Malmö,  
with permission from the Faculty of Medicine, Lund University, Sweden

## **Faculty Opponent**

Professor Jan-Erik Damber,  
Department of Urology, Institute of Clinical Sciences,  
Sahlgrenska Academy, University of Gothenburg, Sweden

Organization LUND UNIVERSITY	Document name DOCTORAL DISSERTATION	
	Date of issue	27 <sup>th</sup> of January, 2012
	Sponsoring organization	
Author(s)	Yasir Ruhayel	
Title and subtitle Male Subfertility and Prostate Cancer Risk: Epidemiological and Genetic Studies		
<p>Abstract</p> <p>Androgen action plays a pivotal role in male reproductive tract physiology and pathology. The androgen receptor (AR) gene harbors two codon repeat tracts: the CAG and GGN repeats, encoding corresponding amino acid sequences of variable length; the polyglutamine and polyglycine stretches, respectively. Variation in CAG repeat length had been associated with a number of andrological disorders, whereas very little was known about the GGN repeat when the work for this thesis was started. We hypothesized that variation in GGN length may modulate AR activity, and hence the individual susceptibility to male reproductive tract disorders. We also assessed the relationship between male subfertility-dependent childlessness and prostate cancer (PCa) risk in a nested case-control study to test the hypothesis that subfertile men are at lower risk of developing PCa than fertile men, since they are frequently hypogonadal secondary to testicular dysfunction. Our specific aims were to investigate: 1) whether the AR codon repeats are associated with clinical reproductive parameters, subfertility, hypospadias, or cryptorchidism; 2) whether childlessness secondary to male subfertility is associated with reduced PCa risk; and 3) the possible involvement of genetic variants in reducing PCa risk in subfertile men, including in the sex steroid signaling pathway and aryl hydrocarbon receptor (AHR) pathway, which mediates some of the effects of endocrine disrupting chemicals, and also in PCa risk genes implicated in previous genome-wide association studies.</p> <p>Our main findings were that: 1) GGN repeat lengths were significantly longer in men with penile hypospadias or cryptorchidism than in controls (median 24 vs. 23) and that the longer allele may be associated with superior AR function; 2) subfertile men were at reduced PCa risk compared with fertile men, OR: 0.45 (95% CI: 0.25-0.83); and 3) genes harboring variants that may play a role in reducing PCa risk in subfertile men include AHR, its partner molecule AHR nuclear translocator (ARNT), and estrogen receptor beta (ESR2), as well as a number of other genes, of which poly (ADP-ribose) polymerase 2 (PARP2) showed the most robust association.</p> <p>We conclude that: 1) longer GGN repeat lengths may be associated with cryptorchidism and hypospadias; 2) subfertile involuntarily childless men are at an approximately 50% lower risk of being diagnosed with PCa than are fathers of at least one biological child; 3) variants in a number of genes may play a role in linking male subfertility with reduced PCa risk through their associations with impaired reproductive function. The findings support the hypothesis that alterations in sex steroid action, potentially via interaction with the <u>AHR-ARNT signaling pathway, may contribute to the overall reduction in PCa risk in subfertile men.</u></p>		
Key words: Androgens; Case-control studies; Genetic association studies; Hypogonadism; Infertility, male; Polymorphism, genetic; Prostatic neoplasms, Receptors, cytoplasmic and nuclear		
Classification system and/or index terms (if any): Yasir.Ruhayel@med.lu.se		
Supplementary bibliographical information:	Language English	
ISSN and key title: 1652-8220	ISBN 978-91-86871-67-3	
Recipient's notes	Number of pages	155
	Security classification	Price

Distribution by (name and address)

I, the undersigned, being the copyright owner of the abstract of the above-mentioned dissertation, hereby grant to all reference sources permission to publish and disseminate the abstract of the above-mentioned dissertation.

Signature:

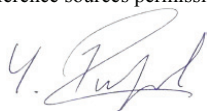

Date: 19<sup>th</sup> of December, 2011

# MALE SUBFERTILITY AND PROSTATE CANCER RISK

Epidemiological and Genetic Studies

Yasir Ruhayel



**LUND UNIVERSITY**  
Faculty of Medicine

Department of Clinical Sciences Malmö  
Molecular and Genetic Reproductive Medicine

Lund University

2012

© Yasir Ruhayel

ISSN 1652-8220

ISBN 978-91-86871-67-3

Cover art: rendered using the thesis text and the program Wordaizer

Lund University, Faculty of Medicine Doctoral Dissertation Series 2012:5

Printed by Media-Tryck, Lund 2011





## TABLE OF CONTENTS

<b>LIST OF ORIGINAL PAPERS .....</b>	<b>9</b>
<b>ABBREVIATIONS .....</b>	<b>11</b>
<b>BACKGROUND .....</b>	<b>13</b>
<b>Androgens and male reproductive health from a historical perspective ....</b>	<b>13</b>
<b>The hypothalamic-pituitary-gonadal axis .....</b>	<b>15</b>
<b>The testis: reproductive hormones in normal physiology .....</b>	<b>16</b>
Leydig cell function .....	16
Spermatogenesis.....	17
<b>The prostate: sex steroids in normal physiology .....</b>	<b>17</b>
Histology .....	17
Secretory function.....	18
Tissue homeostasis and sex steroid action.....	18
<b>Development of the male reproductive tract .....</b>	<b>19</b>
Sex determination.....	19
Development of the testes .....	20
Descent of the testes .....	21
Differentiation of the male internal genitalia .....	21
The mesonephric (Wolffian) ducts.....	22
The urogenital sinus .....	23
Differentiation of the male external genitalia .....	23
<b>Disorders of the male reproductive tract .....</b>	<b>24</b>
The androgen receptor .....	24
General structure and function of the gene and protein.....	24
The CAG and GGN repeats in the N-terminal transactivation domain .....	25
Pathological expansion of the CAG repeat .....	26
Disorders of sex development.....	26
Androgen insensitivity syndrome.....	26
Cryptorchidism.....	27
Hypospadias.....	28
Other disorders of sex development .....	29
Testicular germ cell cancer.....	30
Prostate cancer .....	31
Circulating androgen concentrations, childlessness and subfertility.....	32
Pathogenesis: roles of the sex steroids and their receptors .....	33
<b>Endocrine disruption and the male reproductive tract.....</b>	<b>34</b>
Testicular dysgenesis syndrome .....	34
Male subfertility and semen quality .....	35
Endocrine disrupting chemicals.....	36



The aryl hydrocarbon receptor .....	37
Structure and function .....	37
The AHR pathway in prostate cancer.....	39
Exposure to EDCs and reproductive tract disorders .....	39
<b>AIMS .....</b>	<b>43</b>
<b>MATERIALS AND METHODS .....</b>	<b>45</b>
<b>Study populations .....</b>	<b>45</b>
Swedish military conscripts (I and II).....	45
Infertile men (I).....	46
Boys with hypospadias (II).....	46
Men with cryptorchidism (II).....	46
Men from the “Malmö Diet and Cancer Study” (III-V).....	46
<b>Ascertainment of prostate cancer cases .....</b>	<b>48</b>
<b>Definition of male subfertility .....</b>	<b>49</b>
<b>Genetic analyses .....</b>	<b>49</b>
Analysis of AR gene CAG and GGN repeat tract length (I and II) .....	49
Selection of genes (IV and V).....	50
Selection of htSNPs (IV and V) .....	50
Genotyping and processing of data (IV and V) .....	52
<b>Statistical analysis.....</b>	<b>52</b>
<b>RESULTS .....</b>	<b>55</b>
<b>The AR gene repeats: possible pathological roles .....</b>	<b>55</b>
Male infertility and accessory sex gland function (I).....	55
Cryptorchidism and hypospadias (II).....	58
<b>Male subfertility and prostate cancer risk .....</b>	<b>59</b>
Epidemiological case-control study (III).....	59
Genetic association studies (IV and V) .....	59
<b>DISCUSSION .....</b>	<b>61</b>
<b>SUMMARY AND CONCLUSIONS.....</b>	<b>69</b>
<b>FUTURE PERSPECTIVES.....</b>	<b>71</b>
<b>POPULÄRVETENSKAPLIG SAMMANFATTNING .....</b>	<b>73</b>
<b>ACKNOWLEDGEMENTS .....</b>	<b>75</b>
<b>REFERENCES .....</b>	<b>77</b>
<b>ORIGINAL PUBLICATIONS .....</b>	<b>97</b>

## LIST OF ORIGINAL PAPERS

This thesis is based on the following original publications, which are referred to in the text by their Roman numerals.

- I **Ruhayel Y**, Lundin K, Giwercman Y, Halldén C, Willén M, Giwercman A.  
Androgen receptor gene GGN and CAG polymorphisms among severely oligozoospermic and azoospermic Swedish men.  
*Human Reproduction*. 2004;19(9):2076-83.
- II Aschim EL, Nordenskjöld A, Giwercman A, Lundin KB, **Ruhayel Y**, Haugen TB, Grotmol T, Giwercman YL.  
Linkage between cryptorchidism, hypospadias, and GGN repeat length in the androgen receptor gene.  
*Journal of Clinical Endocrinology & Metabolism*. 2004;89(10):5105-9.
- III **Ruhayel Y**, Giwercman A, Ulmert D, Rylander L, Bjartell A, Manjer J, Berglund G, Giwercman YL.  
Male infertility and prostate cancer risk: a nested case-control study.  
*Cancer Causes and Control*. 2010;21(10):1635-43.
- IV **Ruhayel Y**, Giwercman A, Giwercman YL.  
Genetic Variation in the Sex Steroid and Aryl Hydrocarbon Receptor Signaling Pathways as a Possible Link between Male Subfertility and Prostate Cancer Risk.  
*Submitted*.
- V **Ruhayel Y**, Giwercman A, Giwercman YL.  
Genetic Polymorphisms Associated with Male Subfertility and Reduced Prostate Cancer Risk.  
*Submitted*.

The publications are reprinted with the permission of the copyright holders.



## ABBREVIATIONS

AHR	aryl hydrocarbon receptor
AHRKO	aryl hydrocarbon receptor knock-out
AIS	androgen insensitivity syndrome
AF	activation function
AMH	Anti-Müllerian Hormone
AR	androgen receptor
ARE	androgen response element
ARKO	androgen receptor knock-out
ARNT	aryl hydrocarbon receptor nuclear translocator
BMI	body mass index
BPA	bisphenol A
BPH	benign prostatic hyperplasia
CAIS	complete androgen insensitivity syndrome
CBAVD	congenital bilateral absence of the vas deferens
CFTR	cystic fibrosis transmembrane conductance regulator
CI	confidence interval
CIS	carcinoma <i>in situ</i>
CYP17A	cytochrome P450, family 17, subfamily A, polypeptide 1
DBCP	dibromochloropropane
DBD	DNA-binding domain
DES	diethylstilbestrol
DHT	5 $\alpha$ -dihydrotestosterone
DNA	deoxyribonucleic acid
DSD	disorder of sex development
E2	estradiol
EDC	endocrine disrupting chemical
ER $\alpha/\beta$	estrogen receptor alpha/beta ( <i>protein</i> )
ESR1/2	estrogen receptor 1 (alpha)/2 (beta) ( <i>gene</i> )
FGF	fibroblast growth factor
FSH	follicle stimulating hormone
GD	gonadal dysgenesis
GnRH	gonadotropin releasing hormone
GU	genitourinary
htSNP	haplotype-tagging SNP
HAH	halogenated aromatic hydrocarbon
HPG	hypothalamic-pituitary-gonadal
HR	hazard ratio
HSP	heat-shock protein
HWE	Hardy–Weinberg equilibrium
17- $\beta$ -HSD	17- $\beta$ -hydroxysteroid dehydrogenase

---

INSL3	insulin-like factor 3
LBD	ligand-binding domain
LH	luteinizing hormone
MAIS	mild androgen insensitivity syndrome
MD	mesonephric duct ( <i>Wolffian duct</i> )
MDCS	Malmö Diet and Cancer Study
NKX3-1	NK3 homeobox 1
NR0B1	nuclear receptor subfamily 0, group B, member 1 ( <i>also DAX1</i> )
NR5A1	nuclear receptor subfamily 5, group A, member 1 ( <i>also SF-1</i> )
NTD	N-terminal transactivation domain
OR	odds ratio
PAH	polycyclic aromatic hydrocarbon
PAIS	partial androgen insensitivity syndrome
PCa	prostate cancer
PMD	paramesonephric duct ( <i>Müllerian duct</i> )
PCR	polymerase chain reaction
PGCs	primordial germ cells
PIN	prostatic intraepithelial neoplasia
POP	persistent organic pollutant
p,p'-DDE/T	dichlorodiphenyl dichloroethane/trichloroethane
PSA	prostate-specific antigen
RNA	ribonucleic acid
SBMA	spinal and bulbar muscular atrophy ( <i>Kennedy's disease</i> )
SF1	steroidogenic factor 1 ( <i>also NR5A1</i> )
SHBG	steroid hormone binding globulin
SIR	standardized incidence ratio
SNP	single nucleotide polymorphism
SOX	SRY-related HMG box
SOX3/9	SRY (sex determining region Y)-box 3/9
SRD5A1/2	steroid 5- $\alpha$ -reductase 1/2
SRY	sex determining region Y
TGCC	testicular germ cell cancer
TCDD	2,3,7,8-tetrachlorodibenzo- <i>p</i> -dioxin
TDS	testicular dysgenesis syndrome
TF	transcription factor
UGI	urogenital infection
UGS	urogenital sinus
XRE	xenobiotic response element

---

## BACKGROUND

### Androgens and male reproductive health from a historical perspective

It has been known for millennia in cultures across Eurasia, that the testes are involved in the development and maintenance of “masculine characteristics” [1]. Boys were subjected to castration to provide eunuchs as palace functionaries, a practice which seems to have begun in the late Roman Empire, and which persisted until the Ottoman era [1]. Castration was sometimes used as punishment for prisoners of war in antiquity [1]. It was also a part of the penal and psychiatric systems in several European countries until the 1960s, being enforced for example in the Netherlands as treatment for those committed to asylums for the criminally insane due to sexual offences [2].

In 1889, the physician Charles-Édouard Brown-Séquard described the effects of subcutaneously injecting an extract derived from the testes of a dog and some guinea-pigs [3]. The 72-year old physician, who had suffered a considerable decline in “general strength” during the past decade, reported experiencing improvements in muscular strength as well as physical and mental stamina. However, starting about one month after the last injection, he witnessed a return of his previous “state of weakness”. The Paris Biological Society suggested that the effects may have been caused by “auto-suggestion”, and requested that the findings be replicated. A colleague subsequently performed a trial using testicular extract on three “old” men, aged 54, 56 and 68, who were told they were receiving “fortifying injections”. The effects were very similar to those experienced by Brown-Séquard himself [3].

The biochemists Adolf Butenandt and Lavoslav Ružička respectively identified the structure of [4], and synthesized [5], testosterone (T) in 1935, for which (among other accomplishments) they were awarded the Nobel Prize in 1939. It was subsequently shown that the replacement of androgens in castrated male rats induced mitotic activity in the prostate [6]. Huggins and Hodges reported in 1941 the beneficial results of castration (or injection of large amounts of estrogen) in men with prostate cancer (PCa) and marked elevation of acid phosphatase [7], work for which they were awarded the Nobel Prize in 1966 along with Peyton Rous.

Information on the function of 5 $\alpha$ -dihydrotestosterone (DHT) in humans was gained from the study of the Dominican “guevedoces”, who are men born with ambiguous external genitalia, but who undergo substantial virilization during puberty [8]. The men were found to have markedly decreased concentrations of plasma DHT, caused by a decrease in steroid 5- $\alpha$ -reductase 2 (SRD5A2) enzyme activity [8, 9]. These men thus confirmed that decreased DHT activity *in utero*

results in incomplete masculinization of the external genitalia, while not affecting the internal genitalia. Although virilization occurs at puberty, beard growth is lacking, recession of the temporal hairline does not ensue, and the prostate is small or absent [8]. The understanding that prostate size could be reduced without castration consequently led to the development of the SRD5A2 inhibitor finasteride [10], which was the first effective pharmacological treatment for benign prostatic hyperplasia (BPH) [11], and which was later shown to decrease the risk of developing low-grade PCa [12].

In 1953, a report was published describing individuals with a female phenotype despite having bilateral testes, leading to the coining of the misnomer “testicular feminization” (Morris’ syndrome) [13]. Later studies established that the affected individuals had normal biosynthesis of T and normal androgen metabolism [14]. Generalized tissue resistance to androgens was finally established as the etiology, and the condition was hence termed “androgen insensitivity syndrome” (AIS) [14]. During the 1970s, a specific intracellular androgen receptor (AR) was shown to exist, the defective function of which was consequently implicated in AIS [14].

A hereditary form of defective virilization termed Reifenstein’s syndrome, the features of which include micropenis, perineal hypospadias, cryptorchidism, and gynecomastia, was described in 1965 [15]. The etiology of this syndrome and related disorders was revealed to be partial AIS (PAIS) during the following decades, and it also became clear that the severity of the disturbance in androgen action during fetal development was correlated with the degree of feminization of the external genitalia, hypospadias, and pubertal gynecomastia [14]. Cryptorchidism was also shown to at least in some cases be related to deficient androgen action [14].

In 1996, a study was published suggesting that the incidences of cryptorchidism, hypospadias, poor sperm quality, and testicular germ cell cancer (TGCC) in many industrialized countries during primarily the latter half of the 20<sup>th</sup> century were steadily increasing [16]. Environmental anti-androgens and estrogenic compounds [17], were proposed to act as endocrine disrupting chemicals (EDCs) with potential adverse effects on reproductive health [16]. These studies, together with those showing a link between male infertility and TGCC [18], were integrated into the “testicular dysgenesis syndrome” (TDS) hypothesis, which holds that both genetic and environmental factors are involved in causing a dysgenetic development of the fetal gonad [19], which is the underlying cause of the seemingly correlated increasing incidences of poor sperm quality, cryptorchidism, hypospadias and TGCC [19].

While there is no consensus regarding the validity of the TDS hypothesis, it is clear that the genetics of these reproductive disorders needs to be elucidated, both with respect to directly etiological mutations, and as factors increasing the

susceptibility to the potentially deleterious effects of environmental toxicants. The relationship between androgen action and the normal and diseased functioning of the male reproductive tract is also of interest from the perspective of the hypothesis of antagonistic pleiotropy in sexual selection, which argues that sexually antagonistic coevolution will produce pleiotropic effects, on the one hand increasing fertility, but on the other hand also increasing the risk of sex hormone-dependent cancers, such as PCa [20]. The AR gene is proposed to play an important role in this process [20].

### **The hypothalamic-pituitary-gonadal axis**

In the postpubertal male, the gonadotropins follicle stimulating hormone (FSH), and luteinizing hormone (LH), regulate spermatogenesis and steroidogenesis, respectively. These gonadotropic hormones are secreted from the anterior pituitary in response to the hypothalamic gonadotropic-releasing hormone (GnRH). The hypothalamic-pituitary-gonadal (HPG) axis is activated at puberty by kisspeptin acting on its receptors in the hypothalamus close to the GnRH-releasing neurons [21]. Figure 1 shows the main hormones involved in regulating the adult HPG axis.

LH stimulates the testicular Leydig cells to produce T, which exerts negative feedback control on LH secretion by altering the pattern of GnRH release from the hypothalamus [22]. Estradiol (E2), which is produced from T by aromatization, suppresses LH secretion from the pituitary [23], and decreases GnRH pulse frequency from the hypothalamus [24]. The main enzyme responsible for the conversion of T to E2 is aromatase (cytochrome P450). The production and secretion of FSH is regulated by the peptide hormones inhibin (inhibitory) and activin (stimulatory), which are both members of the transforming growth factor b (TGFb) superfamily [25]. The Sertoli Cell is the main producer of these hormones [25]. Gonadotropin regulation is considered to be the principal physiological role of inhibin, although it also controls several other central biological processes [25].



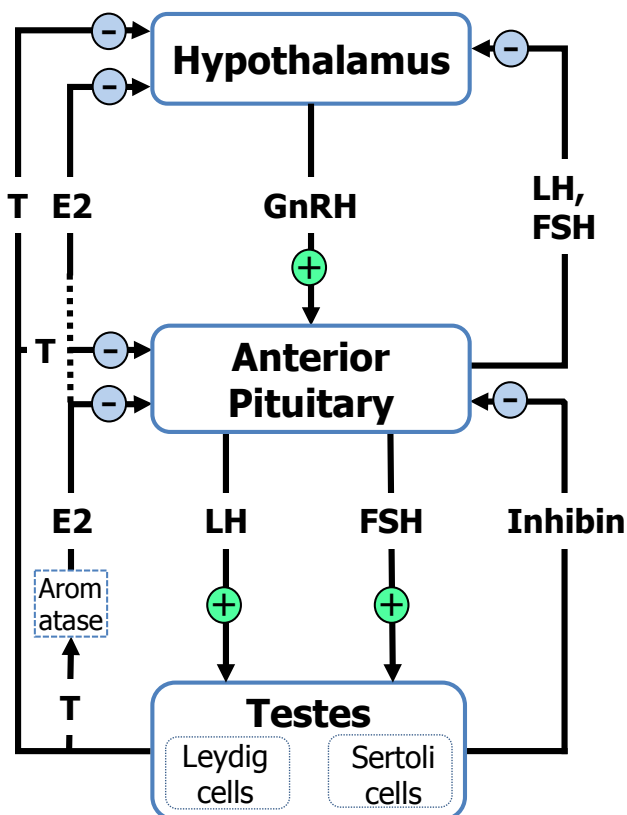

**Fig 1.** Endocrine regulation of the hypothalamic-pituitary-gonadal (HPG) axis. GnRH: gonadotropin releasing hormone, FSH: follicle stimulating hormone, LH: Luteinizing hormone, T: testosterone, E2: estradiol. T is converted to E2 by aromatase.

## The testis: reproductive hormones in normal physiology

### Leydig cell function

Androgens, which like all steroid hormones derive from cholesterol, are mainly synthesized by the Leydig cells in the testis. Intratesticular DHT levels are only 2% that of T, meaning that intratesticular DHT is not significant in normal men, despite greater affinity of DHT for the AR [26]. Furthermore intratesticular T levels are up to one hundredfold higher than in serum [27]. T is central for the regulation of Leydig cell function [27], as is LH.

Estrogens regulate Leydig cell activity not only by suppressing LH secretion, but also by directly inhibiting steroidogenesis via suppression of CYP17A1 (cytochrome P450, family 17, subfamily A, polypeptide 1) [28]. Estrogen receptor alpha (ER $\alpha$ ) is expressed by Leydig cells, and ER $\alpha$ -signaling seems to suppress androgen production [28].

## **Spermatogenesis**

Spermatogenesis is the process by which mature haploid spermatozoa are formed from the diploid  $A_{\text{dark}}$  spermatogonia stem cells [29]. Beginning at puberty, the process takes place in the seminiferous epithelium of the seminiferous tubule and involves cellular differentiation and transformation, mitosis, meiosis, germ cell movement, spermiogenesis (spermatid maturation) and finally spermiation, during which the remaining unnecessary cytoplasm and organelles are eliminated.

Androgen action is required for the normal development of spermatogenesis, spermatozoa, epididymis, vas deferens, seminal vesicles, prostate, and testes [30]. The mechanisms by which androgens control spermatogenesis has been elucidated by various types of testicular cell specific AR knock-out (ARKO) models (reviewed by Walters *et al.* 2010) [30]. Estrogen signaling is also involved in spermatogenesis and appears to affect germ cell proliferation, differentiation and the final maturation of spermatids, as well as germ cell survival and apoptosis [31].

The rate of spermatogenesis is dependent on FSH; as levels increase, the fraction of A spermatogonia in the cycling pool expands, and accordingly, the number of differentiating spermatogonia [29]. LH is needed for the first time during pubertal development, and is not needed for fetal testicular development [32]. LH-null mice have small testes and are infertile due to spermatogenic arrest, which nevertheless recovers spontaneously with age, indicating that even very low (<5% of normal) intra-testicular T concentrations (produced constitutively without LH stimulation) are sufficient for spermatogenesis [32].

## **The prostate: sex steroids in normal physiology**

### **Histology**

The prostate is a tubuloalveolar exocrine gland, the function of which is to store and secrete prostatic fluid. The mature prostate has peripheral, central, and transitional zones, reflecting three sets of ducts [33, 34]. It is a major target of androgen action during fetal development (see p. 23) and in adulthood [34]. T is converted to DHT by SRD5A2 in the prostate, wherein the concentrations of DHT are normally at least an order of magnitude higher than those of T [10].

The prostatic stroma consists of fibroblasts, smooth muscle cells, endothelial cells and immune cells [34]. The prostatic epithelium is compartmentalized into a basal compartment, wherein there is a mixed population of cell types including stem cells and intermediate cells, which share properties of both luminal and basal cells, and a luminal compartment, containing the terminally differentiated secretory cells and the rare neuroendocrine cells [34, 35]. The luminal secretory cells are the major cell type in the epithelial layer. These cells express AR and respond directly

to androgens by simulating production and secretion of prostatic proteins [35]. The basal cells exist as one or two layers attached to the basement membrane and usually have low AR expression [35]. These cells are androgen responsive, regenerating prostatic tissue after re-administration of T after castration [35].

Normal prostatic stem cells have the properties of castration-resistance, tissue-regeneration and self-renewal, and have been shown to exist in the basal epithelial compartment, and probably also in the luminal compartment, wherein rare luminal cells that express the gene NKX3-1 (NK3 homeobox 1) in the absence of testicular androgens (castrate-resistant NKX3-1-expressing cells, CARNs) have been identified [36-39]. The CARNs always express AR and maintain self-renewal capacity [37]. NKX3-1 is gene encoding a transcription factor (TF), which plays a central role in the differentiation of the prostate epithelium, and which acts as a prostate-specific tumor suppressor [40]. The true stem cell hierarchy is unknown, and at least three not necessarily mutually exclusive models have been proposed [35].

### ***Secretory function***

Prostatic fluid constitutes about 20-30% of the volume of semen, and contains concentrations of citrate and zinc that are orders of magnitude higher than in the blood [41]. The secretion also contains proteolytic enzymes such as prostate specific antigen (PSA), and prostatic acid phosphatase. The main structural protein of semen coagulum is semenogelin I, and the high levels of free zinc are thought to inhibit its PSA-mediated degradation, thereby delaying liquefaction [42, 43]. Androgen action is needed for adequate secretory function of the accessory sex glands [30].

### ***Tissue homeostasis and sex steroid action***

Homeostatic epithelial-stromal interactions maintain the highly differentiated, growth-quiescent functional state of both the epithelium and stroma [34]. Prostatic stromal AR is an important positive regulator of epithelial cell proliferation and survival during both prostatic development and tissue homeostasis in adulthood [34, 44]. Epithelial androgen action probably suppresses proliferation and maintains terminal differentiation, while stromal androgen action restrains epithelial apoptosis independent of epithelial AR activation [45].

Estrogens also play a role in prostate tissue homeostasis. Aromatase is exclusively expressed in the stroma where it produces E2, which exerts its effects in both an autocrine fashion via the stromally expressed ER $\alpha$ , and in a paracrine manner via the epithelially expressed ER $\beta$  [46, 47]. Thus, ER $\alpha$  action, which is proliferative and pro-inflammatory, is balanced by ER $\beta$  action, which is anti-proliferative and anti-inflammatory [46, 47].

## **Development of the male reproductive tract**

The foundations for the function or dysfunction of the male reproductive tract in adulthood are laid during fetal development, in which androgens play a central role. Hence, sex determination and fetal sex differentiation are discussed below.

### **Sex determination**

Sex is genetically determined, defined by the sex chromosome complement, which is XX in normal females and XY in normal males [48]. The Y chromosome-linked gene, SRY (sex-determining region Y), appears to be the master initiator of male sex determination in almost all therian mammals [48]. SRY is the founding member of the SOX (SRY-related HMG box) family of transcription factors (TFs) [48]. It probably functions as a TF in humans, upregulating the expression of its direct target gene, SOX9 (SRY-related HMG box-containing gene 9), located on 17q23 [48]. The regulation of SRY itself is poorly understood, but a general outline of the genes involved in sex differentiation is shown in Figure 2.

SRY expression is enhanced by WT1 (Wilms tumor suppressor gene) and also by SF1 (steroidogenic factor 1, encoded by the gene NR5A1) [49]. SRY and SF1 bind directly to specific sites (called “TESCO”, testis-specific enhancer of SOX9 core) lying within the gonadal specific enhancer of SOX9, thereby cooperatively upregulating SOX9 expression [48]. After SOX9 expression has begun, it too binds directly to TESCO with SF1 to auto-amplify its own expression [48]. A positive-feedback loop is also observed between SOX9 and the essential FGF9 (fibroblast growth factor 9) [48]. SF1 additionally activates the expression of Anti-Müllerian Hormone (AMH) in Sertoli cells and steroidogenic enzymes in Leydig cells [50].

SOX9, unlike SRY, is conserved among non-mammalian vertebrate species, and it may be the only gene that is required downstream of SRY to activate the testis-determining program [48]. In the XX gonad, the female genetic pathway is not suppressed, leading to female sex differentiation [48]. These events also occur in XY gonads lacking SRY function, reinforcing the central role for SRY in both activating the testis-determining pathway and suppressing the ovarian-determining pathway [48]. Disorders of sex development (DSDs) are discussed further on p. 26.

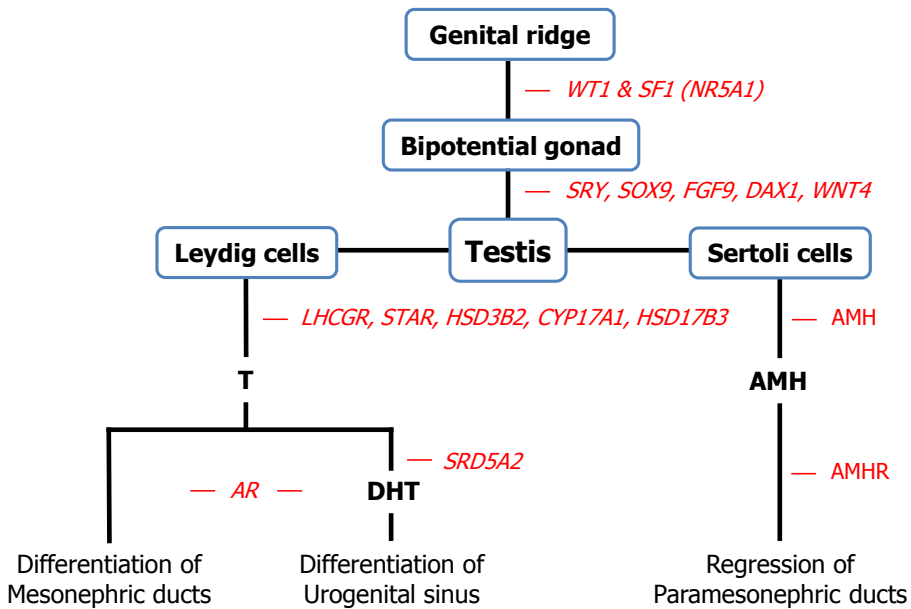

**Fig 2.** The indifferent gonad develops into a testis after the triggering of the male sex differentiation pathway by SRY on the Y chromosome. The normal expression and function of multiple other factors are also required.

### Development of the testes

During weeks 4 to 6 of embryogenesis, the urogenital ridges develop as bilateral thickenings of the mesodermic mesonephros [51]. Epiblast-derived gametic precursor stem cells, known as primordial germ cells (PGCs), migrate from their origin in the yolk sac into the gonadal anlage wherein epithelial cells are proliferating [51]. The PGCs form prospermatogonia which enter mitotic arrest, staying in this state until puberty [51]. Three lineages of somatic cells surround the PGCs; the Sertoli (supporting) cells, which secrete AMH, the Leydig cells, and the peritubular cells, which provide physical support for Sertoli cells and form the blood-testis barrier together with the basal membrane and Sertoli cells [51]. Severely deficient gonadal function results from the failure of any of these lineages to properly differentiate [51].

Starting in week 7, the bipotential gonads differentiate into testes through the action of SRY [49]. The first step in testicular histogenesis is the differentiation of the Sertoli cells [51], which form intercellular membrane connections through the influence of SRY-activated genetic products [51]. The Sertoli cells surround increasing numbers of PGCs, extend into the medulla as gonadal cords, and secrete chemotactic signals that direct the migration of early peritubular myoblasts to the outside of the cords [51]. The lumina of the gonadal cords open up at

puberty, maturing into the convoluted seminiferous tubules [51]. From about week 7, the mesenchymal precursors of the Leydig cells located between the testicular cords start to differentiate, directed by signals from Sertoli cells [51]. At about week 8, the Leydig cells start to produce T, inducing the formation of the ductus epididymidis and vas deferens from the MD [52].

In the early postnatal testis, Leydig cells actively secrete androgens, and there is a peak of androgen production during the second postnatal month (the “mini puberty”) [51]. The Sertoli cells are functionally immature, secreting high concentrations of AMH [53]. Although T synthesis is as active in the fetal and early postnatal periods as in puberty, the Sertoli cells and spermatogenesis remain immature until puberty [53]. This is due to the absence of AR expression in Sertoli cells in the fetal and early postnatal periods, giving a physiological stage of androgen insensitivity [53].

After early infancy, the testes become quiescent during childhood due to a constant inhibition of the prepubertal HPG-axis by hypothalamic neuronal circuits [51]. The Leydig cells regress and T secretion declines dramatically [53]. The Sertoli cells remain immature and spermatogenesis is arrested [53]. At puberty, the Leydig cells differentiate again and restart T production, provoking Sertoli cell maturation and AMH down-regulation, thereby setting off spermatogenesis [53].

### ***Descent of the testes***

The testes are initially located in a perirenal position, attached to the posterior abdominal wall by the cranial suspensory ligament and to the future inner ring of the inguinal canal by the gubernaculum (a fold of peritoneum) [54]. Testicular descent can be divided into three phases. The first phase, transabdominal descent, starts at about week 8, soon after Sertoli cells trigger the differentiation of Leydig cells, which produce androgens and INSL3 (insulin-like factor 3) [51]. Androgens are essential for the regression of the cranial suspensory ligament, while INSL3 mediates gubernacular remodeling, which exerts continuous tension on the testes, anchoring them close to the inguinal canal during fetal growth [54].

The testes pass through the inguinal canal and down to the scrotum during the transinguinal and inguinoscrotal phases [54]. INSL3 is essential for transinguinal movement. The final stage in testicular descent, the inguinoscrotal phase, involves signaling via both the androgen and INSL3 signaling pathways [54]. The testes have usually moved to the scrotum during the final two months of gestation [51].

### ***Differentiation of the male internal genitalia***

The internal genitalia develop from epithelial structures of two types. The seminal vesicle, ejaculatory duct, vas deferens, and epididymis derive from the mesonephric (Wolffian) duct (MD), of mesodermal origin, while the prostate

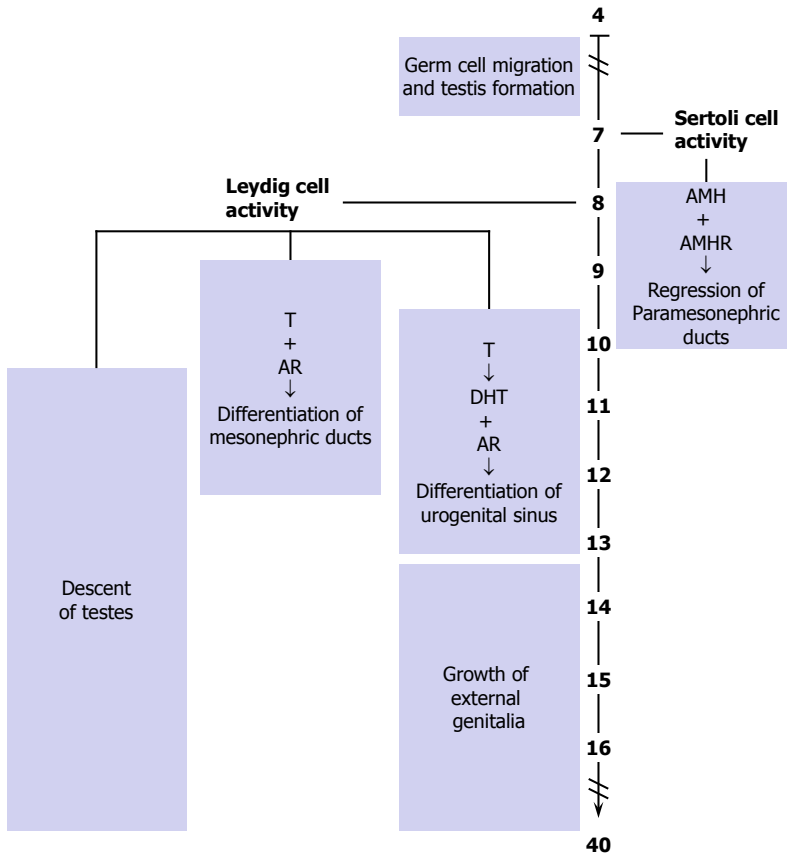

**Fig 3.** Hormonal control of the differentiation of the male internal and external genitalia. AMH: Anti-Müllerian hormone, AMHR: Anti-Müllerian hormone receptor, T: testosterone, AR: androgen receptor, DHT, 5 $\alpha$ -dihydrotestosterone.

derives from the UGS, of endodermal origin [34]. These epithelial structures are associated with mesenchyme derived from mesoderm [55]. Figure 3 shows an overview of the hormonal control of the differentiation of the internal and external male genitalia.

#### *The mesonephric (Wolffian) ducts*

The unipotential duct systems, the paramesonephric (Müllerian) ducts (PMD) and the MD, develop from two mesodermal structures derived from the urogenital ridge, the mesonephros and the coelomic epithelium [49, 52]. During weeks 8 to 9 of development, the PMDs degenerate via apoptosis and cellular transformation under the influence of AMH, produced in high concentrations by the Sertoli cells from the time of differentiation of the testes until puberty [49]. The effect of AMH is ipsilateral, with each testis influencing its own side only [52]. By week 10, the PMDs become insensitive to AMH [49].

At about weeks 6 to 7 of embryogenesis, the MDs develop and stabilize by the action of T [52]. DHT is not involved in this process, since SRD5A2 is not expressed in these tissues until about week 11 of development, at which time the process of internal masculinization is complete [14]. The MD, which originally drains the primitive kidneys, becomes the seminal vesicle, ejaculatory duct, vas deferens, and epididymis when the definitive kidney has developed [52]. The seminal vesicles develop from lateral outgrowths of the caudal end of the vas deferens [56]. The differentiation of the MDs requires the high T concentrations produced in the vicinity of the homolateral testis, which was demonstrated by Jost using unilaterally castrated rabbit fetuses and replacement with crystalline T [56]. The significance of normal androgen action in preventing the degeneration of the MDs is also illustrated by the agenesis of the internal male genitalia exhibited by ARKO mice [30].

### *The urogenital sinus*

The urogenital sinus (UGS) is a cylinder of stratified basal epithelium surrounded by mesenchyme, lying between the embryonic bladder and pelvic urethra, which gives rise to the prostate, bulbourethral glands, prostatic and membranous urethra, and bladder [34]. The differentiation of the UGS requires the action of DHT, as T itself is apparently insufficient to bring about normal development, as illustrated by men with dysfunctional SRD5A2 [8, 9].

Androgen-activated UGS mesenchyme (stroma) induces prostate organogenesis, ductal branching and development, and maintains epithelial cell survival [34, 57]. The prostatic epithelium in turn induces the UGS mesenchyme to differentiate into smooth muscle [34]. Epithelial AR is needed for epithelial terminal differentiation [34], but apparently not for epithelial branching [45]. Various other factors are also essential for normal prostatic development, e.g. the FGF (fibroblast growth factor) family of genes [34].

The prostate continues developing postnatally through “branching morphogenesis” [34], and by puberty the basic prostate architecture is established. The gland subsequently acquires secretory function. The reciprocal stromal-epithelial interactions keep functioning in the adult, maintaining homeostasis (see p. 18).

### ***Differentiation of the male external genitalia***

The external genitalia in both sexes derive from the bipotential anlagen, comprising the genital tubercles, urogenital folds and genital swellings, which are indifferent up until week 9 of embryogenesis [52]. Early in week 4, the terminal portion of the hindgut, called the cloaca, reaches the cloacal membrane, located ventrally on the embryo [52]. A week later, the urorectal septum migrates caudally, dividing the cloaca into the ventrally located UGS, and the dorsal anorectal canal [52]. By week 7, the urorectal septum fuses with the cloacal



membrane, dividing it into a ventral urogenital membrane and a dorsal anal membrane [52]. The membranes then rupture, connecting the amniotic cavity with the UGS and anorectum [52]. The external genitalia begin developing after cloacal partitioning is completed.

In week 4, the genital tubercle is also forming cranially by proliferation of mesenchymal cells surrounding the cloacal membrane [52]. On either side of the cloacal membrane, two pairs of swellings appear distally; the inner urogenital (urethral) folds, and the outer genital swellings [49]. The urethral groove forms ventrally on the phallus, extending along the penis without reaching the glanular surface [52, 58]. The genital tubercle extends forming the penis, while the urethral folds close over the urethral groove, forming the penile urethra [52, 58]. The external meatus and distal urethra form from an invagination of the urethral plate, which is a cord of ectoderm growing from the glans [52, 58].

The urogenital swellings, initially located inguinally, move caudally with continued development and form the scrotum after fusing in the midline (the scrotal raphe) [52]. The external genitalia are clearly male by week 14, but phallic growth continues throughout the last two trimesters [52]. The concentration of T in the fetal circulation is fairly low, and target cells of the external genitalia and prostate express SRD5A2 [59], which is necessary for normal differentiation since DHT induces the virilization of the UGS and external genitalia between weeks 10 and 14 [8, 9].

### **Disorders of the male reproductive tract**

Two types of disorders will be considered below; the DSDs, especially those most affected by deficient androgen action due to genetic factors, and possibly also exposure to EDCs, and the cancers affecting the testis and prostate. Fetal development and the maintenance of testicular and prostatic tissue depend on androgens acting via the AR, and its physiology will therefore be reviewed first.

#### ***The androgen receptor***

##### *General structure and function of the gene and protein*

Originally cloned in 1988 [60, 61], the human AR gene is localized to Xq11-12, giving the karyotypically normal 46,XY male a single copy of this crucial gene [62]. The gene is composed of eight exons which encode a protein of slightly varying length (consensus 920 amino acids), due to variation in the length of two codon repeat tracts [14, 61].

The AR belongs to the steroid hormone receptor subfamily, which is part of nuclear receptor superfamily of receptors [62]. It regulates the expression of a multitude of other genes involved in fetal sex differentiation and the later

development and maintenance of secondary sex characteristics [14]. The AR bears structural similarities to the other steroid hormone receptors, and consists of four functional domains; 1) the N-terminal transactivation domain (NTD) containing a strong ligand-independent “activation function 1” (AF1), 2) the DNA-binding domain (DBD), 3) the small hinge region containing most of the nuclear localization signal, and 4) the C-terminal ligand-binding domain (LBD), which undergoes structural changes following hormone binding, forming a ligand-dependent “activation function 2” (AF2) [62].

Without ligand, the AR is located primarily in the cytosol in an inactive monomeric state, where it associates with heat shock proteins (HSPs) [62]. Upon ligand binding, the AR undergoes a conformational change resulting in its dissociation from the HSPs, thereby enabling the AR to interact with a large number of coregulators [63]. Examples of which include androgen receptor associated protein 70 (ARA70), which cooperates with other coregulators to activate transcription, and filamin A which facilitates nuclear transport [62, 63]. The interactions between the AR and its coregulators facilitate nuclear targeting and subsequent nuclear dimerization [63]. The AR usually functions as a homodimer, but can also form a heterodimer with for example ER $\alpha$ , potentially causing differential transcriptional regulation [62]. Crosstalk with the aryl hydrocarbon receptor (AHR) may also modulate AR action (see p. 37).

Once in the nucleus, the AR DBD binds to specific genomic sequences termed androgen response elements (AREs) in the promoters and enhancers of target genes [62]. The binding to tissue specific AREs enables the recruitment of histone acetyltransferase enzymes, more coregulators and the transcription machinery, thereby inducing or inhibiting transcription of a particular target gene [62]. Aside from the ARs classical genomic activity, there is some evidence that the AR also initiates rapid non-genomic responses on a time-scale of seconds to minutes via action at the plasma membrane or in the cytoplasm [62].

#### *The CAG and GGN repeats in the N-terminal transactivation domain*

The evolutionarily poorly conserved NTD is coded for by exon 1, which is polymorphic in length due to the presence of the CAG and GGN trinucleotide repeat tracts, encoding expanses of repeating amino acid sequences; the polyglutamine stretch and the polyglycine stretch, respectively [14]. The CAG repeat consensus sequence is (CAG)<sub>n</sub>CAA, while the GGN consensus sequence is (GGT)<sub>3</sub>GGG-(GGT)<sub>2</sub>GGC<sub>n</sub>, where the N represents any of the nucleotides C, T or G [61]. Variation in the length of the CAG repeat tract has been linked to a number of disorders [64]. At the time of working with studies I and II, the GGN repeat had not been researched to the same extent as the CAG repeat. However, it had been shown *in vitro* that a 30% reduction in transcriptional activity results from deleting the entire GGN repeat tract [65].

In the general Swedish population, the median number of CAG repeats is 21, with a 95% confidence interval (CI) of 17-29 [66]. There are racial/ethnic differences in CAG repeat number, with the shortest repeats in African populations, intermediate lengths in European whites, and longest lengths in Far-Eastern Asians [67]. As is to be expected by our current understanding of the evolution and global dispersal of our species [68], African populations exhibit the greatest CAG and GGN allele diversity, while Asian populations exhibit the lowest [67].

#### *Pathological expansion of the CAG repeat*

Pathological expansion of the CAG repeat tract to between 37 and 62 repeats is associated with SBMA, also known as Kennedy's disease [69, 70]. SBMA is a late-onset neurodegenerative disorder characterized by MAIS, progressive muscle wasting, and motor neuron death in the spinal cord and brainstem [70]. The etiology is not clear, although the polyglutamine stretch itself may exert a gain of toxic function [70]. It is also possible that nuclear and cytoplasmic aggregates form, or that the elongated polyglutamine stretch destabilizes the AF1 domain, which fails to interact with coregulators, leading to protein misfolding [70].

#### **Disorders of sex development**

The term "disorders of sex development" (DSD) encompasses conditions in which atypical development of the chromosomal, gonadal or anatomical sex has taken place [71]. DSDs hence include a wide spectrum of disorders affecting the genitourinary (GU) tract and reproductive endocrinology. DSDs are common, ranging in severity from genital abnormalities to sex reversal. The incidence of severe DSDs with ambiguous external genitalia is about 1 per 4500 newborns [72].

The molecular etiology of congenital GU defects is poorly understood. Fetal exposure to EDCs [73-77], and mutations in certain genes [78, 79], can affect human GU tract development, but a large proportion are idiopathic. DSDs are frequently associated with major congenital malformations or multiple minor anomalies, suggesting that chromosomal abnormalities may be causative [80], yet traditional karyotype analysis detects low rates of such anomalies [81, 82]. Using other methods, cytogenetically undetectable *de novo* copy number variants have been found to be frequently associated with ambiguous genitalia, cryptorchidism and hypospadias [80]. Mutations in any of the genes involved in the androgen biosynthesis pathway or sex differentiation may potentially cause DSDs, and the number of known relevant genetic aberrations is constantly growing [49]. AIS and certain other DSDs will be discussed in greater detail below.

#### *Androgen insensitivity syndrome*

AIS is divided into three major groups depending on the severity of the phenotype [14, 83]. In complete AIS (CAIS), the external genitalia appear completely female.

The gonads may be located anywhere from the labia majora to the abdomen [59]. A diagnosis is made on the absence of PMD-derived structures and hypoplasia or absence of MD- and UGS-derived structures [59]. The phenotype of partial AIS (PAIS) is very variable, ranging from slight virilization marked by an elongated anogenital distance, to a principally male phenotype with seemingly normal phallic size, but with severe to moderate hypospadias [59]. Most PAIS patients exhibit a combination of reduced phallic size, and severe, mostly penoscrotal to perineal hypospadias. Patients with minimal AIS (MAIS) lack overt genital malformations, but have varying degrees of subfertility [59].

The puberty of patients with CAIS and gonads *in situ* is female with breast development, but secondary sexual hair growth is insufficient [59]. In PAIS, both virilization and feminization may occur, leading to phallic and testicular enlargement with sexual hair growth as well as gynecomastia. Puberty may not develop fully despite apparently normal hormone levels and body proportions are female or intermediate [59].

The majority of 46,XY patients with CAIS carry germline mutations in the coding regions of the AR gene, but this is not the case among patients having PAIS or MAIS [59]. Mutations are most frequently located in the LBD, and more than 800 mutations linked to AIS have been recorded (<http://www.androgendb.mcgill.ca>). The most frequently occurring mutations are single nucleotide substitutions, causing premature transcription termination or amino acid changes. There are also nucleotide insertions, exon duplications and intronic mutations in mRNA splice sites. The same AR mutation may give different degrees of AIS in different carriers [59].

A study on 78 patients with moderate to severe PAIS, found that the CAG  $\geq 23$  repeat lengths were more frequent among undervirilized males than among controls [84]. In another study, CAG repeat length was found to be associated with the severity of undermasculinization when the etiology was unknown (i.e. not due to e.g. AR mutations causing AIS) [85]. However, in a study on 64 Japanese boys with isolated micropenis (a possible manifestation of PAIS), only one AR mutation was found, and CAG repeat lengths were similar to those in the controls [86].

### *Cryptorchidism*

Cryptorchidism, or undescended testis, is the most frequently occurring DSD, the prevalence of which is between about 1-8% in full-term males [75, 87]. Congenital cryptorchidism often resolves spontaneously during the first months of life, at which time T secretion briefly increases [87]. Accordingly, a lower prevalence of 1–2% is reported from 3 to 12 months of age [87]. An increase in prevalence of up to 7% during has been reported in school surveys of prepubertal boys [87]. This apparent increase is most likely due to acquired cryptorchidism, i.e. ascensus testis

and severely retractile testes. A birth weight below 2.5 kg and prematurity are risk factors for cryptorchidism [87]. The possible influence of environmental factors is discussed below (p. 39).

Prospective standardized cohort studies have suggested an increase in the prevalence of congenital cryptorchidism in England between the 1950s and 1980s and in Denmark between the 1960s and 2000 [87]. According to some registries, the incidence of cryptorchidism increased in North and South America in the 1970s and 1980s, but declined after 1985 [87]. The registry data is regarded to be relatively unreliable.

A number of syndromes are associated with cryptorchidism, e.g. Noonan syndrome and Rubinstein–Taybi syndrome [88]. Normal testicular descent is dependent on an intact HPG axis, and any number of mutations may therefore be associated with testicular maldescent [87, 88]. In persistent Müllerian duct syndrome, caused by lack of synthesis or action of AMH, there is no ambiguity of the male external genitalia, but the internal genitalia include a uterus with uterine tubes, and cryptorchidism is frequent [87]. In the most common form of GD, a dysgenetic testis is found together with a streak gonad (mixed GD) [87]. Frequently a 45,X cell line is present, although the karyotype may vary [87]. In phenotypically male newborns with bilateral non-palpable testes, it is important to exclude severe virilization of a 46,XY female as in e.g. congenital adrenal hyperplasia [87].

INSL3-null mice are cryptorchid, with both testes located perirennally [54]. However, it is currently unclear how important INSL3 gene mutations or hormone concentrations are in the etiology of cryptorchidism [54]. As in CAIS patients, the testes of ARKO mice are immature and intra-abdominally located [30]. The few studies on the association between CAG repeat length and cryptorchidism that were published at the time of doing the research for paper II showed no significant associations [85, 89]. There were no studies investigating GGN repeat length in this context.

### *Hypospadias*

Hypospadias is a midline fusion defect of the male ventral urethra causing an abnormal location of the urethral meatus and is estimated to affect 0.2-1% of male newborns [88]. The urethral meatus can vary in location from the ventral aspect of the penile glans (glanular hypospadias) to the scrotum or perineum [88]. Birth defect registries previously underreported the true incidence of hypospadias since mild (glanular and coronal) forms were not registered [88]. However, this type of malformation is common as evidenced by prospective population-based studies that have shown much higher prevalences than the previous estimates of 0.4-2.4 per 1000 total births [88]. Furthermore, many glanular hypospadias become detectable only after the physiological phimosis has disappeared. In Denmark for

example, hypospadias are reported to be present in 4.6% of three year olds, compared with 1% of newborns [88].

Increasing trends of the incidence of hypospadias have been reported in several regions of Europe, the United States, and Australia [88]. However, inaccuracies in ascertainment and reporting, as well as varying diagnostic criteria in registry-based studies have made comparisons and appraisals of the true incidences of the malformation difficult [88]. It is noteworthy that even the lower estimate of hypospadias in Denmark is twice as high as that in Finland [88].

A Swedish study on hypospadias patients found that 6% had cryptorchidism on one or both sides, suggesting that the conditions are associated with one another [90]. However, hypospadias is more frequently associated with other birth defects [91].

Hypospadias can occur as an isolated malformation or as a part of over 200 syndromes that include the anomaly [76, 88]. The types of genetic defects known to be associated with hypospadias can be divided into four main categories [76]. The first category consists of genes participating in the development of the phallus, including the Homeobox and FGF family of genes. Second are the genes associated with testicular dysgenesis, such as WT1 and SOX9. Third are the genes involved in androgen biosynthesis and metabolism. Finally the level of androgen action (sensitivity) can be altered by mutation of the AR gene as in PAIS, although mutations are found in only 20–30% of cases and the phenotype is highly variable.

There were no publications on GGN repeat length and hypospadias when the work for paper II was performed. CAG repeat lengths had been analyzed in a study on boys presenting with varying degrees of undervirilized external genitalia, and CAG lengths were found to be slightly longer in boys with hypospadias (of mainly penoscrotal type), than in the control group [84], although this finding was not replicated in a later study [92].

#### *Other disorders of sex development*

There are two main categories of cytogenetically normal DSDs; 46,XY DSDs with undervirilization and 46,XX DSDs with overvirilization, respectively [79]. Two examples of the former are the androgen biosynthesis defect disorders: 5 $\alpha$ -reductase II (SRD5A2) deficiency and 17 $\beta$ -hydroxysteroid dehydrogenase, type III (HSD17B3) deficiency. Patients with these two disorders undergo partial virilization during puberty, unlike patients with CAIS.

A recent study found mutations in AKR1C2 (aldo-keto reductase family 1, member C2) and AKR1C4 in 46,XY individuals with moderate to severe undervirilization [93]. AKR1C2 is an enzyme that participates in the alternative, but not the classic, pathway of DHT synthesis, suggesting that normal sex

differentiation requires both pathways [93]. Mutations in SF1 (NR5A1) in boys with ambiguous external genitalia and penoscrotal hypospadias or only distal hypospadias have also recently been described [94].

Patients with 46,XY complete gonadal dysgenesis (GD), also known as Swyer syndrome, have normal female external genitalia and PMD-derived structures, but undeveloped “streak” gonads, and are usually not diagnosed until puberty due to absence of secondary sex characteristics [95, 96]. Mutations in SRY account for 10-15% of cases, with mutations in SF1, WT1 and NR0B1, accounting for some of the remainder [97]. The central role of SOX9 was illustrated by a family in which a normal man transmitted a duplication of the gene, resulting in 46,XX male sex reversal and infertility due to azoospermia in affected adults [98]. SOX3 has been identified as being interchangeable with SRY, based on the finding of genomic rearrangements within the SOX3 regulatory region in patients with 46,XX male sex reversal, and on the replication of this phenotype in transgenic mice overexpressing SOX3 [99].

### ***Testicular germ cell cancer***

TGCC accounts for only about 1–2% of all tumors in men, yet it is the most common malignancy in men of reproductive age [100]. The incidence of TGCC is highest in developed nations with primarily Caucasian populations and lowest in Asia and Africa [100-102]. The incidence varies geographically in Europe with North-South and East-West gradients. Norway and Denmark have the highest age-standardized incidence rates at around 9-10 per 100 000 man-years, while Estonia and Spain have the lowest at about 2-3 [102]. Using instead truncated age-standardized incidence rates for the age-group 15-54, the incidence in Denmark is about 17%, in Norway 12%, in Sweden 8%, and in Finland 4% [103].

The reasons for these geographic patterns in TGCC incidences are unknown, although one contributing factor may be differences in genetic background; e.g. the Finns differ from the Scandinavian, North German and British populations [104]. On the other hand, migrant studies from Sweden and Denmark indicate that TGCC incidences move toward those of the adopted country after one generation, but that the incidences in first-generation migrants are unchanged in relation to their countries of origin [105-108]. These findings imply that early, probably pre-natal environmental exposures play a large role in determining risk, although genetic susceptibility to the effects of the exposure may also be involved [102, 105].

The rates of TGCC have been increasing in many populations over time and across successive birth cohorts, including those in the Nordic countries, the United Kingdom, Germany, France, the United States, and Australia [102]. TGCC mortality has been declining in Western European countries since the mid-1970s,

thanks to platinum-based chemotherapy and best-practice tumor management programs [103].

Several factors are consistently associated with an elevated risk of TGCC, namely prior history of TGCC, family history of TGCC and cryptorchidism [109]. There is also some evidence that low birth weight and gestational age are risk factors for the malignancy [109]. A recent meta-analysis corroborated that male subfertility is associated with increased TGCC risk, even in subfertile men with no prior history of cryptorchidism [18]. Hypogonadism due to gonadal dysfunction is common in men with TGCC [110]

DSDs are generally associated with an increased risk of germ cell tumors [79]. The risk appears to be highest (about 15-35%) in SRY-positive GD and in PAIS with intra-abdominal gonads [79]. Conversely, TGCC risk in CAIS is lower at about 1-2% [79]. A Danish national register-based cohort study found that having hypospadias or cryptorchidism was associated with an increased risk of TGCC, although there was no association with a positive family history of the disorders [111]. Maternal steroid hormone concentrations during early pregnancy may also affect TGCC risk [112].

### ***Prostate cancer***

Among European men, PCa is the most common non-skin cancer, and is the second or third most common cause of cancer-related mortality [113]. The “true” incidence of PCa is difficult to estimate since the malignancy is frequently sub-clinical, detected only via PSA testing [114]. The incidence of PCa has been increasing in most Western countries since the 1970-80s [113], which is most probably a result of increased PSA testing (and screening) during the past two decades [113, 115]. Before PSA-based testing was introduced, mortality from PCa was steadily increasing, which was most likely caused by increasing longevity [113, 116]. In the USA and certain other countries age-standardized PCa-specific mortality rates have decreased to a level lower than before the era of PSA-based screening [116]. In many other countries, including Finland, Norway and (probably) Sweden, PCa-specific mortality has decreased, although rates remain higher than before PSA testing became widespread, while in yet other nations, such as Denmark, mortality from PCa has continued to increase [116].

Even within countries, there are clear differences in PCa incidence and mortality. In e.g. the USA, the risk-adjusted incidence rate for PCa in the 60-69 age group (2005-7 data) is estimated to be >700 per 100 000 for whites, and >1 200 per 100 000 for blacks [115]. PCa-specific mortality is also substantially higher in African-Americans than in Caucasian Americans [117]. However, although PCa incidence is also higher for UK blacks than whites, there is no evidence that their disease-specific mortality is higher [117]. Nonetheless, genetic differences probably account for at least part of the disparity in incidence, since the frequency



of the susceptibility alleles at PCa risk loci is higher in men with black African heritage [117].

#### *Circulating androgen concentrations, childlessness and subfertility*

It is well-established that PCa is hormone-dependent [7], and studies have therefore been carried out to investigate whether androgen concentrations in the circulation are associated with PCa risk. A meta-analysis on 18 prospective studies found no evidence that elevated androgen concentrations in the circulation are associated with excess PCa risk [118]. However, another meta-analysis using a different methodology found that proportional differences in T were associated with proportional disparities in PCa incidence across different populations [119]. In cross-sectional studies on men with already established disease, T levels are generally lower in patients with high grade PCa or metastasized disease, than in men with PCa of lower grade and stage [120]. This relationship may reflect an effect of the disease itself [120].

A chronic reduction in androgen action has indirectly been shown to be associated with reduced PCa risk, as evidenced by the finding of only two cases of non-fatal disease in a study of 3,518 men with Klinefelter syndrome [121], for whom congenital hypogonadism is a typical feature. Additionally, the Prostate Cancer Prevention Trial (PCPT) showed that men treated with finasteride exhibited a 25% reduction in the overall rate of PCa diagnosis [12]. Similarly, in the Reduction by Dutasteride of Prostate Cancer Events study (REDUCE), the overall relative risk reduction for PCa men treated with dutasteride was 23% [122].

Androgen concentrations in the circulation correlate poorly with the corresponding concentrations in the prostate [10, 123, 124]. Therefore, fertility status in reproductive age, and hence testicular function [125, 126], may function as a better estimator of the degree of long-term androgenic stimulation of prostatic tissue than an assessment of circulating androgen concentrations later in life, at which time a tumor may already have developed.

Involuntary childlessness has been used as a proxy indicator for reproductive function in young adulthood, since more detailed information is usually unavailable due to the historical lack of medical assessments of fertility. In two national cancer registry-based studies, childless men were found to be at significantly lower risk of PCa than men who had fathered a child [127, 128]. These studies thus provide evidence for an association between childlessness and PCa risk. However, they did not exclude cases of childlessness attributable to other factors than male subfertility, and only adjusted the analysis for age [127, 128], and marital status [128].

---

*Pathogenesis: roles of the sex steroids and their receptors*

Androgens play a central role of in the pathogenesis of PCa. Androgens induce cell proliferation in PCa cell lines [129, 130], act as PCa promoters [131, 132], and androgen deprivation in animal models prevents PCa development [133]. As detailed above, men with chronic hypogonadism are at very low risk of the malignancy. Furthermore, PCa has not been reported in men with congenital SRD5A2 deficiency [9].

African-Americans have the highest incidence of PCa in the USA, and racial differences in CAG repeat lengths have therefore been proposed to contribute to this disparity [70], especially since *in vitro* studies suggest that there is an inverse relationship between CAG repeat length and AR gene transcription efficacy as well as AR transactivation function [70]. However, the relationship between CAG repeat lengths and PCa risk is unclear, as some studies have found that PCa risk is increased among men with shorter repeat tracts, while others have not [70].

Current research suggests that AR stimulates proliferation in stromal cells, functions as a survival factor in luminal epithelial cells, and may function as a suppressor of PCa progression and metastasis in basal intermediate-like cells (reviewed by Zhu *et al.* 2010) [44]. Slightly different results have been obtained in other studies which indicate that androgen action in both basal and luminal epithelial compartments is capable of initiating oncogenic transformation [134].

The role of estrogens in PCa development has been studied for a number of reasons [46, 47, 131]. Importantly, the prostatic stroma is a site of E2 production [46]. Animal models have shown that both increased serum androgen levels caused by deficient aromatase activity, and increased prostatic AR induced by elevated estrogen exposure can lead to stimulation of prostate growth [135]. Others have shown that adding E2 to T treatment markedly increases PCa incidence [131, 136]. Additionally, estrogen metabolites known as catecholestrogens are directly genotoxic as well as inducers of oxidative stress [47, 131]. Furthermore, the serum T:E2 ratio decreases with age due to decreased T synthesis, increases in sex hormone-binding globulin (SHBG), and increases in adiposity and peripheral aromatase [46, 47].

In the normal prostate, the stromal cells express AR and ER $\alpha$ , while the epithelial cells express AR and ER $\beta$  (and ER $\alpha$  at very low levels) [46, 47, 137]. During tumor progression from high-grade prostatic intraepithelial neoplasia (PIN) to PCa, the expression of the antiproliferative ER $\beta$ 1 is lost in the basal epithelial cells along with the disruption of the basement membrane [47]. Throughout the development and progression of PCa, tissue E2 levels increase, while DHT decreases [47]. These changes are due in part to an increase in aromatase activity and a loss of SRD5A2 expression [47], and in part to the age-related changes in systemic T:E2 balance [46, 47]. Animal studies suggest that expression of the

proliferative ER $\alpha$  in the epithelium is enhanced by either castration or by epithelial AR inactivation [138], and that epithelial ER $\alpha$  is required for estrogen-mediated proliferative response, whereas stromal ER $\alpha$  is not [137].

There is some evidence that the fetal hormonal milieu, especially regarding exposure to estrogens (“estrogen imprinting”), plays a role in determining the later risk of developing PCa [47, 139]. One study reported that longer gestation age was associated with a small reduction in PCa risk [140]. This somewhat paradoxically suggests a longer period of estrogenic exposure, although this is only one of a large number of factors related to gestational duration.

## **Endocrine disruption and the male reproductive tract**

### ***Testicular dysgenesis syndrome***

In 1992, a meta-analysis of semen quality data was published that showed a significant secular decline in sperm concentrations and semen volume in otherwise normal men during the period from 1938 to 1990 [141]. Four years later, a report showed increasing incidences of cryptorchidism, hypospadias, impaired spermatogenesis, and TGCC in a number of industrialized countries over the latter half of the 20<sup>th</sup> century [16]. It was proposed that environmental anti-androgens, in addition to the previously suggested estrogenic compounds [17], could act as endocrine disrupting chemicals (EDCs) with potential adverse effects on male reproductive health [16]. This hypothesis was based on animal exposure studies, and on the observation that sons of women treated during pregnancy with diethylstilbestrol (DES) had substantially increased incidences of cryptorchidism, hypospadias, poor semen quality and possibly TGCC [16].

It has become evident that TGCC originates in carcinoma *in situ* testis (CIS), which closely resembles fetal gonocytes [142]. An increasingly strong case has also been made that subfertile men are at increased risk of developing TGCC [18], as are men with cryptorchidism or hypospadias [111]. Other similar earlier studies taken together with the adverse trends in male reproductive health, laid the foundation for the TDS hypothesis, which holds that both genetic and environmental factors were involved in causing a dysgenetic development of the fetal gonad, which in turn was the unifying cause underlying the apparently correlated increases in the incidences of poor sperm quality, cryptorchidism, hypospadias and TGCC [19]. The rapid increase in incidence of TDS was suggested to be due to adverse life-style and/or environmental influences, such as prenatal exposure to EDCs [19]. While the TDS hypothesis is not generally accepted, especially concerning the inclusion of hypospadias [143, 144], certain aspects of it are supported by both laboratory and epidemiological studies [74, 88, 145].

Paralleling the adverse trends in male reproductive health, a Danish and an American study both published in 2007 reported substantial secular, age-independent declines in circulating T concentrations from the 1980s onwards [146, 147]. The changes in T concentrations were attributable changes in body mass index (BMI) in the Danish [146], but not in the American study [147]. The decrease may perhaps reflect a decline in testicular function, although the replicability and etiology of the trend need further study.

### **Male subfertility and semen quality**

It is estimated that about 10-15% of all couples are involuntarily childless after at least 12 months of regular unprotected intercourse [148]. Subfertility can be attributed to male factors, female factors, or a combination thereof. The male contributes at least partly to the childlessness in an estimated 7% of all cases [149].

Impaired sperm production and function can be caused by dysfunction at the pre-testicular, testicular or post-testicular level [149]. Causative genetic factors can be identified in about 15% of cases and include karyotype anomalies (e.g. Klinefelter syndrome), Y chromosome microdeletions, Kallmann syndrome, congenital bilateral absence of the vas deferens (CBAVD), mutations in genes in the HPG axis, and AIS [149]. The etiology is idiopathic in about 50% of cases [149]. At the time of performing our research, a number of studies had been published on the relationship between subtle changes in CAG repeat length and male subfertility, although results were inconsistent. Long CAG repeat lengths were found to be associated with decreased sperm concentrations in some studies [150-152], but not others [153]. The association between GGN repeat numbers and subfertility had only been investigated in a few studies. In 1997, Tut *et al.* reported no significant differences in distributions of GGN repeat lengths between infertile men and fertile controls [151], which was later corroborated by Lundin *et al* from our group [66].

Pre-testicular male subfertility is mainly a result of congenital or acquired hypogonadotropic hypogonadism or coital problems (erectile dysfunction, retrograde ejaculation) [149]. Post-testicular causes of subfertility include all obstructive lesions of the seminal tract, infections and inflammatory diseases of the accessory sex glands, and autoimmune infertility [149]. Azoospermia results when there is bilateral obstruction, whereas varying degrees of impairment of the major sperm parameters may be present in the other conditions. CBAVD with agenesis of the seminal vesicles is a mild manifestation of cystic fibrosis, and mutations in the CFTR (cystic fibrosis transmembrane conductance regulator) gene are common in affected men [154].

Diseases of the accessory sex glands are associated with low ejaculatory volume, and inflammatory conditions typically present with seminal fluid leukocytosis.

Activated leukocytes produce reactive oxygen species that may affect sperm function [149]. About <5% of infertile men suffer from an autoimmune reaction against spermatozoa, which can be triggered if the blood-testis barrier has been breached due to previous testicular or epididymal inflammation (e.g infection) [149].

About 75% of all male subfertility is related to primary testicular failure [149], which is often accompanied by hypogonadism [125, 126]. Impaired semen quality is also the most central entity in the TDS hypothesis, especially when dysgenetic testis histology is also present [74]. However, the association with TDS is less clear in the majority of men with poor semen quality as the sole symptom, as the etiology may be heterogeneous and post-natal contributing factors may also be present [74].

Geographical differences have been reported in a number of studies, which taken together suggest that an East-West gradient exists in the Nordic-Baltic area, with higher semen quality and lower risk of TGCC in e.g. Finland and Estonia, and the opposite pattern observed in Denmark and Norway, with Sweden having an intermediary position [155]. Recent adverse trends in semen quality and TGCC risk have been reported in Finnish men, indicating that (changing) environmental and/or life-style-related exposures may be causative [156].

### ***Endocrine disrupting chemicals***

In 1988 a report on the state of the environment of the North American Great Lakes was published, which raised public awareness that persistent chemicals were being transferred from predator females to their offspring, thereby undermining their organ development prenatally [157]. Three years later a World Wildlife Federation (WWF) conference stated that many compounds introduced into the environment by humans are capable of disrupting the endocrine system of animals including humans and that endocrine disruption can be profound because of the crucial role hormones play in development [157].

Over the last few decades, there have been numerous reports of adverse effects on the reproductive capacity of wildlife and laboratory animals caused by exposure to EDCs [16, 158, 159]. The increasing trends in human male reproductive disorders, and the growing evidence for causative environmental factors have therefore sparked growing interest in the health threat posed to humans by EDCs, which are substances in our food, environment, and consumer items that interfere with hormone action, biosynthesis, or metabolism, resulting in disrupted tissue homeostasis or reproductive function [73, 158].

The mechanisms of EDCs involve a wide array of actions and pathways. Examples include the estrogenic, androgenic, thyroid, and retinoid pathways [73, 158], in which the EDCs may act directly as agonists or antagonists, or indirectly via other

nuclear receptors, such as the AHR [73, 158]. They can also disrupt steroidogenic enzymes and many other pathways that are highly conserved in wildlife and humans [73]. Some EDCs have been targeted to block the reproduction of humans and other animals, including synthetic estrogens (e.g. DES), pesticides (e.g. dichlorodiphenyl dichloroethane *p,p'*-DDE), nematocides (e.g. dibromochloropropane, DBCP), and insecticides (e.g. metrifonate) [73, 158]. Other EDCs adversely affecting human reproduction include fungicides (e.g. vinclozolin), herbicides (e.g. 2,3,7,8-tetrachlorodibenzo-*p*-dioxin, TCDD), plastics (e.g. bisphenol A, BPA), plasticizers (e.g. phthalates) and phytoestrogens (e.g. isoflavones) [73].

The persistent organic pollutants (POPs) constitute a large class of variably degradation-resistant organic EDCs [160]. POPs are often halogenated, and have low water solubility but high lipid solubility, leading to their bioaccumulation in fatty tissues [160]. They are semi-volatile and can travel long distances in the atmosphere before being deposited [160]. POPs noted for their persistence and bioaccumulative characteristics include many of the first generation organochlorine insecticides such as dichlorodiphenyl trichloroethane *p,p'*-DDT and chlordane, and industrial chemical (by)products including polychlorinated biphenyls (PCBs), dibenzo-*p*-dioxins (dioxins) and dibenzo-*p*-furans (furans) [73, 160]. Many of these compounds have been or continue to be used in large quantities. Some, such as PCBs, may persist for years and bioconcentrate by four to five orders of magnitude.

One of many pathways mediating the harmful effects of EDCs is the AHR signaling pathway, which will be covered in some detail below because it interacts with both the AR and ER [161], and since it was identified as a possible link between male subfertility and PCa risk in study IV.

### ***The aryl hydrocarbon receptor***

#### ***Structure and function***

The AHR is a member of the basic helix-loop-helix/Per/ARNT/Sim (PAS) superfamily of TFs [162]. The AHR is encoded by a gene consisting of 11 exons located on 7p15 [162], which is highly conserved across invertebrate and vertebrate species [163]. The receptor regulates the metabolism of xenobiotic substances, but also modulates the expression of certain genes and the activity of other TFs, thereby influencing e.g. apoptosis, proliferation, and differentiation [162].

AHR activity is modulated by environmental chemicals, various food constituents and also by endogenously formed substances [162]. Most high-affinity AHR agonists are synthetic chemicals, including halogenated aromatic hydrocarbons (HAHs) such as dioxins, furans, and PCBs, and polyaromatic hydrocarbons

(PAHs) such as Benzo[*a*]pyrene (BaP) [162]. The naturally occurring AHR-ligands are a large group mainly comprising food constituents of plant origin, most of which also inhibit TCDD- or BaP-stimulated AHR signaling [162].

The mechanism for AHR-induced transcription is closely related to that of steroid hormone receptors. Without ligand the AHR is primarily found in a cytoplasmic complex, which includes an HSP90 homodimer, the co-chaperone p23, and the immunophilinlike Ara9 (also known as XAP2 or AIP) [163]. Ligand binding increases shuttling of the receptor to the nucleus, wherein an AHR/ARNT heterodimer is formed which binds to regulatory sequences known as xenobiotic response elements (XREs), or dioxin response elements (DREs), in the promoters of target genes [163]. Several such genes encode enzymes, such as the xenobiotic metabolizing cytochrome P450 (CYP)1A1, CYP1B1, and glutathione S-transferase [164], although most have unknown functions [163].

The AHR is involved in normal physiology and development, as demonstrated by the AHR knock-out (AHRKO) mouse model, which exhibits greatly reduced liver size because of vascular defects, hepatic fibrosis, cardiac hypertrophy, disturbed immune system function, and significantly reduced fertility due to disturbances in some reproductive organs [162, 163]. Moreover, AHRKO mice are resistant to acute TCDD toxicity, the teratogenic effects of TCDD (cleft palate and hydronephrosis), and BaP carcinogenicity [162]. The AHR also seems to play a role in prostatic development [33].

The direct target genes of the AHR alone do not fully explain its physiological and toxicological effects [165]. Liganded AHR promotes the ubiquitination and proteasomal degradation of the ERs and AR by assembling the ubiquitin ligase complex, CUL4B<sup>AhR</sup> [165, 166]. The ubiquitin-proteasome system regulates cellular protein degradation and is thus of central importance in cellular homeostasis [165].

The AHR modulates the function of the AR, ER $\alpha$  and ER $\beta$  via cross-talk [165], which seems to be an intrinsic function of the AHR [166, 167]. It is the active form of the AHR, and not the ligand itself that is required for AHR-ER $\alpha$ /AR cross-talk [167]. The main effect is anti-estrogenic [161, 168, 169]. However, differences seem to exist between the ER subtypes with respect to their interactions with ARNT, which has a stronger enhancing effect on the activity of ER $\beta$  than on ER $\alpha$  [169]. Moreover, TCDD has stronger anti-estrogenic effects on ER $\beta$  than on ER $\alpha$  [169].

A mouse model with a constitutively active AHR showed dioxin exposure-like effects on reproductive organs, and also corroborated previous research indicating that activated AHR has antiestrogenic effects in the presence of estrogen, but estrogenic effects in the absence of estrogen [170].

### *The AHR pathway in prostate cancer*

In LNCaP cells, TCDD blocks androgen-induced cell proliferation [171]. Treatment with TCDD or BaP causes a decrease in AR protein levels [172], which may be a result of the AHR ubiquitin ligase function. Indeed, co-treatment with TCDD has been shown to decrease T-dependent AR transcriptional activity [171].

However, TCDD has no effect on PC-3(AR) (AR transfected) cells, which exhibit a normal response to combined TCDD and DHT treatment (i.e. cell cycle arrest), and no response to TCDD treatment alone [171]. DHT-dependent transcriptional activity and AR protein levels were found to be unaffected by TCDD co-treatment in the absence of exogenous coactivator expression [171].

Knocking out the AHR gene in PCa model (TRAMP) mice inhibits prostatic carcinogenesis [173], while treating TRAMP mice with an AHR modulator inhibits metastasis [174]. However some studies suggest that activation of the AHR may play a role in cancer invasiveness by causing deregulation of cell-cell contact [175].

### **Exposure to EDCs and reproductive tract disorders**

The most widely studied dioxin, TCDD, was a contaminant of the defoliant Agent Orange used during the Vietnam War [176]. There is some evidence that prenatal exposure to TCDD may increase the risk of PCa in adulthood [177], while it is less clear whether exposure in adulthood, such as in Vietnam War veterans, increases the risk [178]. The most severe large-scale human exposure to TCDD was the Seveso accident in 1976 [179]. Studies on reproductive function in sons of the exposed mothers, have shown that *in utero* and lactational exposure of children to relatively low dioxin doses can permanently reduce sperm quality, manifested as reductions in sperm concentration, total count, progressive motility, and total motile count [179]. Animal studies have shown similar effects of fetal exposure on adult sperm counts [158], and also indicate that maternal exposure suppresses fetal testicular steroidogenesis, potentially resulting in testicular maldevelopment [180]. Another case of accidental exposure to high concentrations of POPs was the Taiwanese Yu-Cheng rice oil poisoning accident, after which men who had been exposed *in utero* to PCBs were reported to have higher proportions of abnormal and dysfunctional spermatozoa in their semen than unexposed men [181].

The PAHs are constituents of exhaust fumes, smoke and cooking processes [158]. Several large studies have shown substantial reductions in sperm counts in men whose mothers had smoked heavily during pregnancy [158]. As studies did not find significant effects on the quality of sperm produced, a possible interpretation is that Sertoli cell numbers were reduced. Furthermore fetal exposure of laboratory animals to diesel exhaust results in reduced sperm production in adulthood, an effect shown to depend partly on reduced Sertoli cell numbers [158]. A



mechanism compatible with reducing Sertoli cell numbers in adulthood is inhibited androgen action via AHR activation (see p. 37) during fetal development [158].

A US study showing that high consumption of beef by mothers during pregnancy was associated with a reduction in sperm counts in their adult sons may be explained by a similar mechanism [158]. However, other compounds are also plausible, such as DES, which was widely used to enhance growth in cattle in the relevant period [158]. Additionally, several studies have shown associations between maternal exposure to a range of EDCs during pregnancy and increased risk of reproductive disorders other than poor sperm quality [158]. However, results are inconsistent regarding associations between exposure to a specific chemical or chemical class and risk of reproductive disorder, and it is therefore likely that any effect on the developing testis may result from exposure to a mixture of EDCs.

Recent prospective studies have established links between perinatal exposure to POPs and cryptorchidism, as well as between phthalates and anti-androgenic effects in newborns [75]. Maternal alcohol consumption, mild gestational diabetes and nicotine substitutes were also identified as potential risk factors for cryptorchidism [75]. Additionally a recent nested case-control study on 1442 French newborns reported a significant association between parent's occupational exposure to pesticides and male genital malformations, including cryptorchidism, hypospadias, and micropenis [77]. Another study found that maternal occupational or dietary (fish and shellfish) exposure to EDCs was associated with increased risk of hypospadias in the sons [182]. In another study, total effective xenoestrogen burden in placental tissue was found to be a risk factor for cryptorchidism and/or hypospadias in the offspring [183]. It may hence be the cocktail effect of many simultaneous exposures that result in adverse effects, especially during fetal life and infancy [75].

Animal studies have provided evidence for a fetal “masculinization programming window”, during which exposure to anti-androgenic chemicals is associated in adulthood with reduced testicular size [184], and hypospadias and cryptorchidism [185]. The effects of maternal dioxin exposure or smoking may potentially be explained by this type of mechanism, as dioxin exposure may result in reduced androgen action during the masculinization programming window [158]. The most commonly detected pesticide contaminant of ground and surface water is the EDC atrazine, which alters male reproductive tissues in fetally exposed animals [186]. Atrazine demasculinizes and feminizes the gonads by producing testicular lesions associated with reduced germ cell numbers [186]. Androgen levels are reduced and estrogen synthesis induced [186].

Certain phthalates cause a syndrome of abnormalities of the male reproductive tract including hypospadias and cryptorchidism in fetally and neonatally exposed animals [187]. These effects are associated with decreased fetal T production during the masculinization programming window [187], mediated by changes in the expression of numerous enzymes and transport proteins involved in T biosynthesis and transport in the fetal Leydig cell [187]. INSL3 is also significantly down-regulated and may hence be responsible for the commonly occurring cryptorchidism [187]. *In utero* phthalate treatment is also associated with lowered spermatocyte numbers in postnatal animals [187].

A modestly increased risk of hypospadias associated with pesticide exposure was found in a meta-analysis, despite potential misclassifications of exposure (and phenotype) [188]. A large case-control study published later found that maternal occupational exposure to EDCs with estrogenic (some pesticides) or anti-androgenic (phthalates) properties was associated with an increased risk of hypospadias in their sons [189]. However, no single EDC has yet been identified as a cause of hypospadias in humans. Nevertheless, hypospadias may serve as a model for gene-environment interactions due to the sensitivity of male urogenital tract development to perturbations in sex steroid signaling [76].

The possible effects of fetal exposure to EDCs and drugs on PCa risk are difficult to study in humans for a number of reasons (e.g. long lag time, diagnostic uncertainties, and a multitude of potential confounders). Nevertheless, mouse models have shown that exposure to exogenous estrogen during fetal development results in permanent effects on adult prostate size and function, which is mediated through ER $\alpha$  [135]. The xenoestrogen BPA binds to both ER subtypes as well as to AR, is highly prevalent in the environment, and is detected in >90% of people in the USA [135, 139]. Exposure to exogenous estrogens or BPA in concentrations relevant to human exposure causes disruption of the expression of AR and ER in mesenchymal tissue, leading to permanent increases in adult prostate size and the formation of PIN after treatment with T and E2 [57, 135, 190]. Epidemiological studies have reported associations between exposure to specific pesticides, PCBs, and inorganic arsenic, and elevated PCa risk [177]. Animal models have also show augmentation of prostatic carcinogenesis with several other xenoestrogens including cadmium, UV filters, and BPA [139, 177]. The sensitivity of the prostate to EDCs is also heightened during critical developmental windows in utero, neonatally and during puberty [139, 177, 190]. Thus, infants and children may be considered a highly susceptible population for EDC exposures and increased PCa risk with aging.

Clarifying the roles of the sex steroids in PCa development is an important step in attempting to understand the possible effects of exposure to EDCs, which may sensitize the prostate to hormonal pathogenesis during fetal development and later maturation by disturbing the balance between the actions of the steroid hormones.



## AIMS

The overarching aim of this thesis was to investigate the possible epidemiological and genetic associations between deficient androgen action (hypogonadism) and disorders of the male reproductive tract.

The specific aims were to:

- examine whether the CAG and GGN repeat tracts in the AR gene are associated with disorders of sex development, including subfertility, hypospadias, and cryptorchidism;
- study the possible link between variation in the lengths of the CAG and GGN repeat tracts and male reproductive function;
- investigate whether childlessness secondary to male subfertility is associated with reduced PCa risk in a nested case-control study;
- explore the possible involvement of polymorphisms in genes in the sex steroid signaling and AHR signaling pathways in reducing PCa risk in subfertile men;
- analyze the role of polymorphisms in PCa risk genes implicated in previous GWAS in linking male subfertility with decreased PCa risk.



## MATERIALS AND METHODS

### Study populations

#### **Swedish military conscripts (I and II)**

In 2000, the vast majority of all 18 year old Swedish men took part in the (at the time) mandatory military conscription process, which included a medical health examination. The only men who were routinely excluded were those with severe chronic diseases prohibiting their participation in the conscription process. These men therefore closely reflected the general population in their age group.

Between May and December 2000, all 2 255 men born 1979-1982 who were living within 60 km from Malmö, Sweden, and who underwent the health examination, were asked to participate in a study on semen quality in young men from Southern Sweden [191]. The number of men agreeing to participate was 305 (13.5%). The median age of the men at examination was 18.2 years (range 18-21 years).

The participants answered a questionnaire at home. Information was collected regarding pre- and postnatal factors potentially influencing their reproductive function, e.g. place of birth, ethnicity and known congenital genital malformations. As a part of this study, the men underwent a physical examination at Skåne University Hospital, Malmö, which included assessment of body proportions, external genitalia and virilization. Any andrological abnormalities, including current or previous congenital malformations were noted.

Semen analysis was carried out in accordance with the World Health Organization (WHO) 1999 guidelines. The men were asked to abstain from ejaculation 48–72 h prior to semen collection, but in each case, the actual length of abstinence was recorded. Concentration of spermatozoa was assessed using a modified Neubauer chamber. The seminal activities or concentrations of neutral- $\alpha$ -glucosidase (NAG), PSA, fructose and zinc, were assessed. The concentrations of FSH, LH, SHBG, T, E2, and Inhibin B in the circulation were measured, and free T was estimated using the formula by Vermeulen, *et al.* [192].

In study I, an ethnically matched control group was needed for the comparison of the infertile men with an average male population. This group consisted of the 223 men with mothers of Swedish ethnic origin among the 305 conscripts. The median age of these 223 men at medical evaluation was 18 years (range 18–19). In study II, the same ethnically matched control group was used as above, with the exception of the exclusion of three men with insufficient DNA, nine subjects with a history of cryptorchidism, and one with a history of hypospadias, giving 210 remaining controls.

***Infertile men (I)***

We included 144 men with a history of at least one year of infertility and sperm concentrations  $<5.0 \times 10^6/\text{mL}$ , as determined by at least two consecutive semen analyses, who were undergoing clinical evaluation prior to *in vitro* fertilization (IVF) or intracytoplasmic sperm injection (ICSI) at the Department of Reproductive Medicine at Skåne University Hospital Malmö, Sweden. The exclusion criteria were: (i) endocrine disturbances due to hypogonadotropic hypogonadism or abuse of androgenic (anabolic) steroids, (ii) obstructive syndromes of the urogenital tract, and (iii) previous treatment with chemotherapeutic agents. For study I, only the 99 patients whose mothers were of Swedish ethnic origin were included for sequencing of the AR gene to reduce possible confounding due to ethnic stratification bias.

***Boys with hypospadias (II)***

Fifty-one boys with isolated hypospadias were referred to Astrid Lindgrens Children's Hospital, Stockholm, Sweden for surgery. The patients were white and native born. They were divided into three groups according to the position of the urethral orifice and degree of chordee. The subtypes of hypospadias used for the classification was glanular, penile, and penoscrotal hypospadias. Blood samples for genetic analyses were collected. All subjects were included in study II.

***Men with cryptorchidism (II)***

This group consisted of a total of 23 men with mothers of Swedish ethnic origin, of which nine were excryptorchid military conscripts, and 14 were infertile men with a self-reported history of cryptorchidism, selected from 81 consecutive patients at the Department of Reproductive Medicine, who also had sperm concentrations  $<5.0 \times 10^6/\text{mL}$  in two consecutive semen samples.

***Men from the "Malmö Diet and Cancer Study" (III-V)***

The original aim of the Malmö Diet and Cancer Study (MDCS) was to investigate whether a diet high in fat and total calories, while low in vegetables, fruit and fibers, increases the risk of certain types of cancer. In 1993 the MDCS became an associated member of the European Prospective Investigation into Cancer and Nutrition (EPIC). The study design and recruitment process have previously been described in detail [193, 194], but a summary will be presented below.

All subjects living in the city of Malmö, Sweden, between January 1<sup>st</sup>, 1991 and September 25<sup>th</sup>, 1996 were invited to participate in MDCS. Men born between 1923 and 1945 and women born 1923-1950 were eligible. According to the population register, there were in total 74 138 individuals in the selected birth cohorts, of which 31 514 were men and 42 624 were women. The background population was invited by letter, with reminder letters sent twice. In addition to

invitation by personal letter, subjects living in Malmö from the studied birth-year cohorts were invited by advertisement in local newspapers, in public places and in primary health care centers.

Subjects with insufficient Swedish language skills or mental incapacity were excluded, leaving 68 905 eligible subjects, of which 28 873 were men and 40 032 were women. According to the 2007 MDCS Endpoint Report (with end of follow-up at Dec 31<sup>st</sup>, 2006), there were 30 447 participants in the MDCS cohort, of which 12 121 were men, and 18 326 were women. The male capture rate was thus approximately 38% of the target male population.

Baseline data were acquired by a self-administered questionnaire and physical examination, and a blood sample was obtained by venipuncture. The questionnaire provided information regarding educational attainment, occupation, physical activity, social network, use of tobacco and alcohol, physical health, medical history, prescribed medication, and disease in close relatives. Anthropometric data, including height, weight, and body fat proportion (measured using an impedance method), were registered. Body mass index (BMI) at baseline was calculated from height and weight and was estimated at 20 years of age using the self-reported weight at that age.

The participants included in study III were recruited from the MDCS cohort. Of the 1 322 eligible participants (661 PCa cases and 661 controls), 975 (74%) men responded with a completed survey. The flow of participants through the study is detailed in Figure 4. We excluded the 77 men stating that they had never tried to beget a child and accordingly had unknown fertility status. Of the remaining 898 men, we further excluded seven individuals in childless relationships where a medical evaluation of the couple had revealed only female-factor infertility, and the childlessness therefore most likely was a consequence of the partner's infertility. Thus, 891 (67%) men were included, providing 445 (50%) PCa cases and 446 (50%) controls without diagnosed PCa.

The subjects in studies IV and V were the same as those who were included in study III, except that only men who had DNA samples of sufficient quantity for genotyping were included, giving 430 (97%) PCa cases and 427 (96%) men without diagnosed PCa.



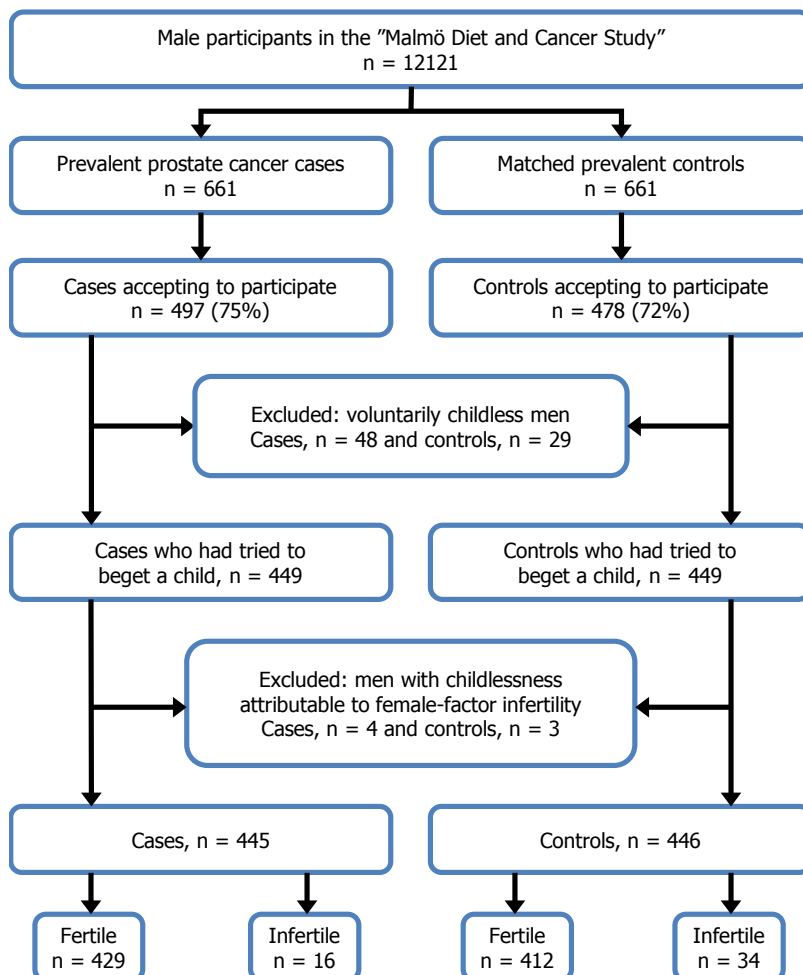

**Fig 4.** Process of selection of cases and controls for inclusion in the study. Men stating that they had never tried to beget a child, and who hence had unknown fertility status, were excluded. Men who were childless due to female-factor infertility were also excluded.

### Ascertainment of prostate cancer cases

Data from the Swedish National Cancer Registry was used to identify all 661 prevalent PCa cases in the MDCS cohort who were registered as participating and still alive as of December 31<sup>st</sup>, 2006. For each index case, one living control without diagnosed PCa at the end of follow-up was randomly selected from the MDCS cohort, matching for sex, age ( $\pm 90$  days), and the date of enrolment in the cohort ( $\pm 90$  days). Tumor stage at diagnosis, assessed by digital rectal examination, was obtained from patient records at the Department of Urology at Skåne University Hospital Malmö. Histopathological tumor grading was performed by any of three senior, National Board-certified pathologists at Skåne

University Hospital Malmö, using specimens from the diagnostic prostate biopsies.

### **Definition of male subfertility**

The epidemiological definition of subfertility (infertility) is the inability to conceive after a 12-month period of unprotected intercourse. Subfertility can be attributed to male factors, female factors, or a combination thereof. In studies III-V, a narrower definition of male subfertility was used, where only men with an enduring (life-long) history of involuntary childlessness were categorized as subfertile, excluding those cases where a previous medical evaluation of the couple had revealed exclusively female-factor subfertility. Childless men who reported having contributed to a pregnancy were consequently classified as fertile, as were childless men with deceased offspring.

### **Genetic analyses**

#### ***Analysis of AR gene CAG and GGN repeat tract length (I and II)***

The length of the CAG and GGN repeat tracts in the AR gene were determined by direct sequencing of PCR product. The sequence of the GGN repeat tract is both GC-rich and repetitive, resulting in the formation of very stable secondary structures which will not work as needed in a PCR. Therefore, the GGN repeat tract was amplified using deaza-nucleotides and a nested procedure, i.e. utilizing a pre-amplification step. Genomic DNA for use in the PCR was extracted from peripheral leukocytes.

The CAG repeat tract was amplified in one step in a 50 µL reaction containing 0.4 µM of each of the primers AGCCTAGCAGGGCAGATCTT (forward) and CTGCCTTACACAACCTCTTGGC (reverse), 0.25 µM of each dNTP, 1 x Pyrobest II PCR buffer, 1.25 IU Pyrobest DNA Polymerase and approximately 10-50 ng of DNA. Amplification was performed for 35 cycles, with the program consisting of denaturation at 96°C for 45 s, a combined annealing and extension step at 72°C, an initial denaturation step at 96°C for 3 min, and a final extension step at 72°C for 5 min. The negative control consisted of PCR mix without DNA.

The GGN repeat tract was amplified in a 25 µL PCR mix containing 10 ng of DNA, 0.3 µM of each of the primers CCAGAGTCGCGACTACTACAACCTTCC (forward), and CCAGAACACAGAGTGACTCTGCC (reverse), 2.5 mM MgCl<sub>2</sub>, 200 µM of each of dATP, dCTP and dTTP, 100 µM of dGTP and 7-deaza-dGTP, 45 mM KCl, 10 mM Tris-HCl and 0.5 IU of Dynazyme DNA polymerase. Amplification was carried out for 40 cycles, with the program consisting of denaturation at 96°C for 1 min, primer annealing at 56°C for 1 min and primer extension at 72°C for 3 min, an initial denaturation step at 96°C for 3 min, and a

final extension step at 72°C for 7 min. PCR mix without DNA served as a negative control.

The subsequent nested amplification PCR consisted of 30 cycles at 96°C for 1 min, 52°C for 20 s, and 72°C for 3 min, with an initial denaturation step at 96°C for 3 min and a final extension step at 72°C for 7 min. A 50 µL reaction was prepared containing 1 µL of the PCR product from the first reaction, 200 µM of each dNTP, 0.25 mM of each of the primers ATCCCCACGCTCGCATCAA (forward), and CCAGAACACAGAGTGACTCTGCCCT (reverse), 0.65 M Betaine, and 1.2 IU Dynazyme DNA polymerase. The negative controls were pure PCR mix and a mix with 1 µL of the negative control from the first PCR.

The products from the nested PCR were purified using the Jetpure PCR purification kit. Approximately 30 ng of the purified products were submitted to a 20 µL sequencing reaction with the CEQ Quickstart kit and the forward primer AGCCGCCGCTTCCTCATCCT, as described by the manufacturer. Sequencing products were ethanol-precipitated according to standard procedures, and re-suspended in sample loading solution provided in the kit. Samples were analyzed externally on a Beckman Coulter CEQ 2000XL sequencer. The entire AR gene was sequenced according to methods described previously [195], in subjects in whom a mutation in the GGN repeat was found.

### ***Selection of genes (IV and V)***

In study IV, 16 candidate genes were selected based on their participation in the sex steroid signaling and AHR pathways. In addition, AMH and its receptor (AMHR2) were included, since AMH is produced by the Sertoli Cell and studies suggest that AMH concentrations in seminal plasma and/or serum may be lower in sub- and infertile men [196].

In study V, the results from genome-wide association scans (GWAS) and candidate gene studies on PCa risk loci were used to select 19 genes of interest for analysis. Poly (ADP-ribose) polymerase 1 and 2 (PARP1 and PARP2) were additionally included due to their known involvement in infertility-related phenotypes, and their multiple cellular functions ranging from maintenance of genomic stability to the regulation of cell death [197]. A polymorphism in the PARP1 gene has previously also been associated with PCa risk [198].

### ***Selection of htSNPs (IV and V)***

The HapMap database (Release 27) was used to select haplotype-tagging SNPs (htSNPs) capturing all variation (with  $r^2 > 0.80$ ) within the gene and 20 kilobases upstream and downstream, using the Tagger Multimarker algorithm and restricting htSNPs to those with a minor allele frequency (MAF)  $>5\%$  in the HapMap CEU samples (<http://www.hapmap.org>). The flanking sequences were tagged to cover

the promoters as well as other regions of potential importance to the transcription or function of the gene.

In study IV, 12 genes were tagged with 90 htSNPs, including 4 in AR, 11 in AHR, 9 in AMH, 3 in AMHR2, 7 in ARNT, 16 in ESR2, 5 in follicle stimulating hormone, beta polypeptide (FSHB), 7 in heat shock protein 90kDa alpha (cytosolic), class A member 1 (HSP90AA1), 7 in luteinizing hormone beta polypeptide (LHB), 5 in nuclear receptor subfamily 0, group B, member 2 (NR0B2), 10 in sex hormone-binding globulin (SHBG), and 6 in SRD5A2. For these genes, the following missense SNPs were also included: rs1800053 (A114D) in the AR, rs6659176 (G171A) in NR0B2 and rs6260 (R25H) in SHBG.

For four genes, only missense SNPs with MAF >5% (in the CEU or AFD\_EUR samples) were evaluated: rs1800053 (P189A) and rs35008248 (L114P) in aryl-hydrocarbon receptor repressor (AHRR), rs4072568 (G679S) in aryl-hydrocarbon receptor nuclear translocator 2 (ARNT2), rs6165 (A281T) and rs6166 (S654N) in follicle stimulating hormone receptor (FSHR) and rs12470652 (N291S) and rs2293275 (N312S) in luteinizing hormone / choriogonadotropin receptor (LHCGR).

In study V, a total of 108 htSNPs were used to tag 13 genes. Certain htSNPs captured variation in multiple genes in close proximity to one another. The number of htSNPs per gene, excluding overlapping coverage, was 4 in G1- to S-phase transition 2 (GSPT2), 14 in insulin-like growth factor 2 (somatomedin A) (IGF2), 4 in insulin-like growth factor 2 antisense (IGF2AS), 7 in insulin (INS), 10 in lemur tyrosine kinase 2 (LMTK2), 4 in melanoma antigen, family D, 1 (MAGED1), 14 in microseminoprotein, beta- (MSMB), 17 in NK3 homeobox 1 (NKX3-1), 6 in nudix (nucleoside diphosphate linked moiety X)-type motif 10 (NUDT10), 2 in NUDT11, 12 in PARP1, 10 in PARP2, and 4 in tyrosine hydroxylase (TH). Missense SNPs with MAF >5% (in CEU or AFD\_EUR samples) were also included for the following genes: rs12807478 (P28S) in IGF2AS, and rs11765552 (M780L) and rs3735252 (P30A) in LMTK2.

For eight genes, only missense SNPs or previously clinically associated SNPs with MAF >5% (in the CEU or AFD\_EUR samples) were evaluated: rs2304789 (T412M) in copine III (CPNE3), rs10934853 (intronic) in eukaryotic elongation factor, selenocysteine-tRNA-specific (EEFSEC), rs2710646 (intronic) and rs721048 (intronic) in EH domain binding protein 1 (EHBP1), rs4430796 (intronic) and rs7501939 (intronic) in HNF1 homeobox B (HNF1B), rs11895564 (A380T) in integrin, alpha 6 (ITGA6), rs10486567 (intronic) in JAZF zinc finger 1 (JAZF1), rs17253672 (P363L), rs2454206 (I1762V), rs34402524 (L1721W) and rs7679673 (5'-UTR) in tet methylcytosine dioxygenase 2 (TET2), and rs1465618 (intronic), rs17031056 (V699L), rs33979934 (T1385S), rs35720761 (C1605Y) and rs7578597 (T1187A) in thyroid adenoma-associated (THADA).

**Genotyping and processing of data (IV and V)**

Genotyping was performed at the Region Skåne Competence Centre (RSKC Malmö), at Skåne University Hospital, Malmö, Sweden using the Sequenom iPLEX Gold assay and MassARRAY MALDI-TOF (matrix-assisted laser desorption/ionization-time of flight mass spectrometry) platform. Assays were performed using randomly sorted DNA samples from PCa cases and controls, as well as positive and negative controls supplied by the manufacturer.

Genotyping data were stored and processed in SNPator (<http://www.snparator.org>) [199], allowing for calculation of allele and genotype frequencies, expected heterozygosity, and Hardy–Weinberg equilibrium (HWE). Deviation from HWE was not used as a criterion to exclude a SNP from further analysis.

Due to poor genotyping performance across SNPs, 26 samples (3%) were excluded, leaving 418 PCa cases (97%; 403 fertile, 15 subfertile), and 413 controls (97%, 383 fertile, 30 subfertile). In study IV, all 14 (14%) SNPs with call rates <95% were excluded from further analysis, as were 2 (2%) that were monomorphic in our samples, leaving 84 (84%) in the analysis. In study V, 15 (12%) SNPs with call rates <95% were excluded from further analysis, leaving 113 (88%) in the analysis.

**Statistical analysis**

The statistical calculations were conducted using SPSS versions 11-18 (SPSS Inc., Chicago, IL, USA), unless otherwise stated. A two-sided  $p < 0.05$  was generally considered to indicate statistical significance. The choice of the statistical method used for analyzing descriptive parameters was based on the type of data distribution and sample size.

Fisher's exact test or the Chi-square ( $\chi^2$ ) were applied for testing differences in outcomes between groups. Distributions of parameters were compared using the Kruskal-Wallis test (or the Mann-Whitney  $U$  test), when the distributions were non-parametric. Means of (roughly) normally distributed variables were compared using Student's  $t$ -test. Spearman's rho ( $\rho$ ) was calculated to assess the degree of correlation between CAG and GGN repeat lengths.

In study I, the association of the two most common GGN alleles (23 and 24) with the reproductive attributes of the infertile men was also assessed in binary logistic regression models, which provided odds ratios (ORs) and 95% confidence intervals (95% CI) for having, respectively, reduced prostatic function and/or low testicular volume, i.e. <30 mL (the median value). The "prostate function variable" was defined as a binary variable in which men having seminal zinc and/or seminal PSA concentrations below the medians were categorized as having subnormal prostate function, with the rest having normal function. Plasma T levels

and CAG repeat length were also included as covariates in the models, as they are potentially confounding factors. The same models were applied to the control group (conscripts) using the medians of the respective values in that group to define the categories of the variables.

In study III, we evaluated the association between male subfertility and PCa in conditional binary logistic regression using available matched pairs as well as in age-adjusted unconditional binary logistic regression using all available subjects. We performed a stepwise screening of other potential explanatory variables, including socioeconomic, anthropometric, and health-status-related factors for possible inclusion in a subsequent multivariate analysis. The factors were eliminated if they did not change the estimate of the principal model by >15%. We also fitted three multivariate models which included a number of variables previously reported to be associated with PCa risk, as well the variable indicating history of urogenital infection (UGI), since this latter parameter emerged as a significant independent predictor in the stepwise screening.

In studies IV and V, we began by verifying that the subset of men genotyped in the studies was representative of the whole cohort (study III), by using logistic regression to confirm the association between male subfertility and reduced PCa risk. In the principal genetic analysis, the 30 subfertile men without diagnosed PCa were compared with the 403 fertile men with PCa (the referent group). Odds ratios (ORs) and 95% confidence intervals (95% CIs) for the association of the minor allele of each SNP with subfertility and PCa were estimated using age-adjusted unconditional logistic regression, coding the counts of minor allele as an ordered continuous variable. The genotypic associations were analyzed in an additive model, except when there were no homozygotes for the minor allele, in which case a dominant model was used instead.

In the two genetic studies, we evaluated whether the associations identified in the principal analysis were independently associated with subfertility by performing a secondary regression analysis in which the 30 subfertile men without PCa were compared with the group of 394 fertile men without PCa. The same methodology as described above was used to assess the allelic and genotypic associations.

As a large number of association tests were performed, the false discovery rate (FDR) [200] associated with each allelic regression test was calculated using the “qvalue” package [201] in R (<http://www.r-project.org>). The “*q*-value” assigned to each statistical test quantifies the minimum FDR incurred when that test’s *p*-value is taken to indicate statistical significance. Haploview version 4.2 was used to calculate the *D'* and *r*<sup>2</sup> values for the linkage disequilibrium (LD) between pairs of SNPs.



## RESULTS

The AR gene CAG and GGN trinucleotide repeat polymorphisms were studied with regard to infertility and accessory sex gland function in paper I, and in relation to the risks of having a history of cryptorchidism or hypospadias in paper II.

The association between childlessness secondary to male-factor subfertility and PCa risk was investigated in the epidemiological study in paper III. The possible association of genetic variation in the sex steroid signaling and AHR pathways with male subfertility and PCa risk was explored in paper IV. In the final paper (V), we explored the potential contribution of genetic polymorphisms in PCa risk genes (identified in previous GWAS), to the association between subfertility and PCa risk.

### **The AR gene repeats: possible pathological roles**

#### ***Male infertility and accessory sex gland function (I)***

We screened the 99 infertile men with mothers of Swedish origin for genetic abnormalities prior to AR gene sequencing, revealing karyotypic abnormalities in five (5%) patients, and Y chromosome microdeletions in another five (5%) patients. These 10 men were excluded from further analysis.

The distributions of CAG and GGN alleles in the 89 infertile men compared with the 223 controls are shown in Figures 5 and 6. The distributions of repeat lengths did not differ significantly between groups; GGN ( $p = 0.19$ ) and CAG ( $p = 0.16$ ), respectively. The two most common GGN lengths occurred with similar frequencies in both controls and patients, 53% vs. 52%,  $p = 0.90$ , and 37% vs. 32%,  $p = 0.41$ , for 23 and 24 GGN repeats, respectively. Conversely, the proportion of not 23 or 24 GGN repeats did not differ significantly between groups (10% vs. 16%,  $p = 0.20$ ).

The median CAG repeat length was 22 in the patients and 21 in the conscripts. The proportion of alleles with short (<21) CAG repeat lengths among the infertile men, 15/85 (18%), was significantly ( $p = 0.005$ ) lower than in the controls, 76/223 (34%). However, the proportion of short CAG alleles was not significantly higher ( $p = 0.07$ ) in the controls compared with patients with idiopathic infertility, 11/53 (21%). The <21 CAG/23 GGN repeat haplotype occurred more frequently ( $p = 0.003$ ) in the conscripts, 36/223 (16%), than in the infertile men, 3/79 (4%), and also than in the subgroup with idiopathic infertility, 2/51 (4%,  $p = 0.02$ ). The <21 CAG/24 GGN combinations did not differ significantly ( $p = 0.56$ ) in prevalence between the conscripts, 29/223 (13%), and the infertile men 8/79 (10%).



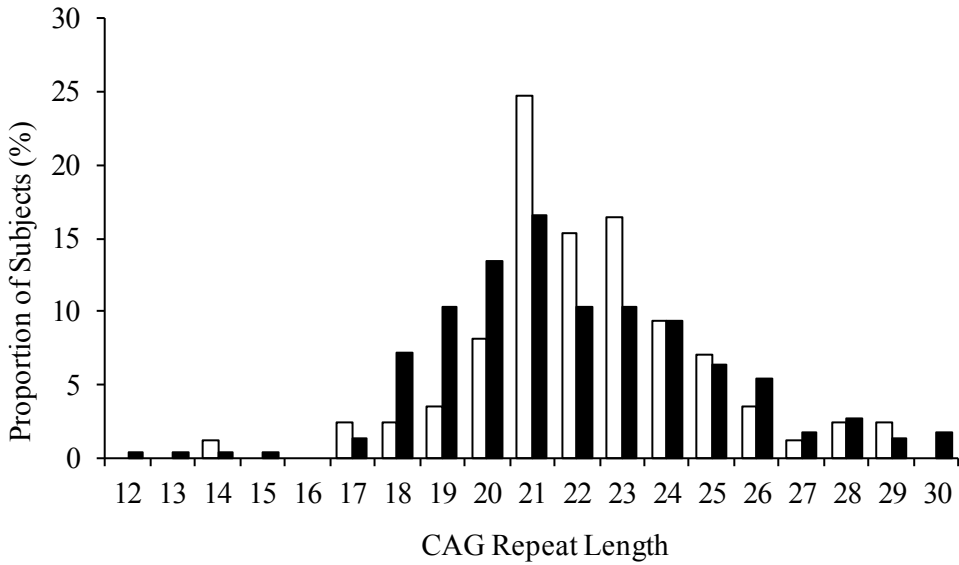

**Fig 5.** Distributions of the lengths of the CAG repeat tracts in infertile men ( $n = 85$ , white bars) and conscripts ( $n = 223$ , black bars).

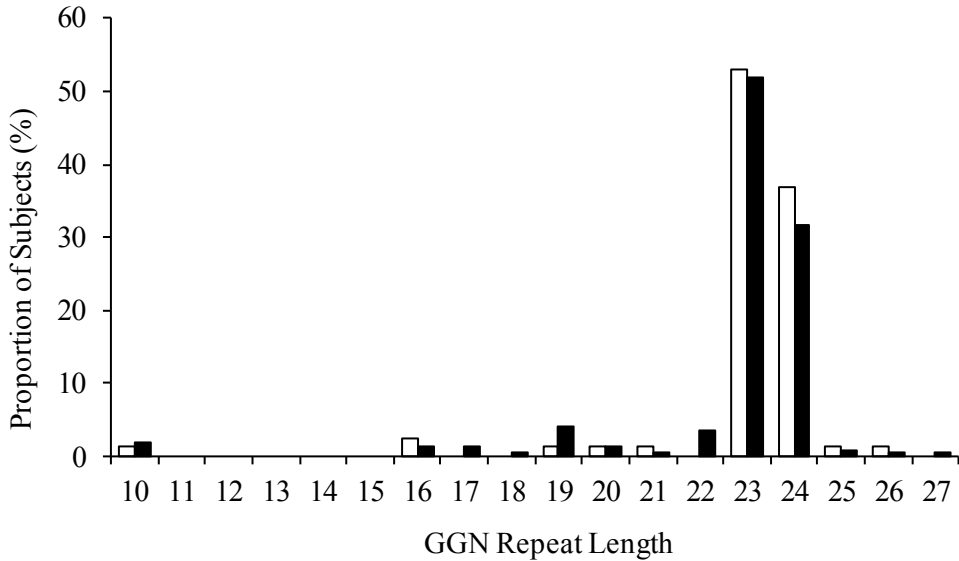

**Fig 6.** Distributions of the lengths of the GGN repeat tracts in infertile men ( $n = 81$ , white bars) and conscripts ( $n = 223$ , black bars).

In Table I, infertile men carrying 23 GGN repeats are compared with those carrying 24 repeats. The former group had significantly higher values of total testicular volume ( $p = 0.04$ ) and CAG repeat lengths ( $p = 0.002$ ) than the latter. However, the conscripts did not exhibit significant differences in total testicular volume ( $p = 0.46$ ), or CAG repeat lengths ( $p = 0.08$ ).

**Table I.** Comparison of seminal, hormonal and physical reproductive parameters and CAG repeat lengths in infertile carriers of the AR gene alleles with 23 GGN repeats ( $n=43$ ) vs. 24 repeats ( $n=30$ ).

	23 GGN repeats median (range)	24 GGN repeats median (range)	$p^*$
Sperm concentration, $\times 10^6/\text{mL}$	0.35 (0.0-5.0)	0.53 (0.0-3.6)	0.99
Seminal volume, mL	3.2 (0.2-8.6)	3.0 (1.3-7.0)	0.65
Seminal zinc, mmol/L	2.3 (0.2-5.3)	1.4 (0.2-10.1)	0.08
Seminal PSA; mg/L	800 (190-2500)	600 (100-2310)	0.13
Seminal fructose, mmol/L	15.9 (4.2-29.8)	16.2 (0-50)	0.95
FSH, IU/L	8.5 (1.7-35.0)	9.3 (2.9-48.7)	0.14
LH, IU/L	3.8 (1.2-9.6)	3.8 (1.8-15.9)	0.28
Testosterone, nmol/L	13.3 (2.7-28.7)	14.5 (4.8-31.9)	0.92
SHBG, nmol/L	28 (14-77)	30 (11-112)	0.75
Inhibin B, ng/L	77 (10-252)	77 (10-226)	0.49
Total testicular volume, mL	34 (12-50)	25 (5-50)	0.04
CAG repeat length	23 (20-29)	21 (14-27)	0.002

\* $p$ -values are from the Mann-Whitney  $U$  test.

Regression analysis showed that the risk of having subnormal prostatic secretory function was higher among the infertile men having the 24 GGN allele compared with the men with the 23 GGN allele, OR (95% CI): 3.5 (1.1–11.7),  $p = 0.04$ . However, this was not significant in the subgroup of men with idiopathic infertility ( $p = 0.29$ ), or in the controls ( $p = 0.26$ ). The infertile men with the longer allele were also at higher risk of having total testicular volume below the median (30 mL), OR (95% CI): 5.2 (1.6–17.0),  $p = 0.007$ , as were the men with idiopathic infertility, OR (95% CI): 5.0 (1.1–23.4),  $p = 0.04$ , whereas the conscripts were not ( $p = 0.08$ ).

**Cryptorchidism and hypospadias (II)**

In the hypospadias patients, eight different GGN alleles were found. Only the two most common alleles, 23 and 24 GGN, were present in excryptorchid patients. No differences were found in GGN repeat lengths in the entire group of hypospadias patients compared with controls (Table II). However, men with penile hypospadias had significantly longer GGN repeats compared with controls, median 24 vs. 23 ( $p = 0.003$ ). The same pattern was found for excryptorchid men compared with controls ( $p = 0.001$ ). Moreover, the GGN repeat lengths among subjects with penile hypospadias were significantly different compared with the other two hypospadias subgroups combined ( $p = 0.018$ ). The distributions of GGN repeat lengths in the controls and patients groups and are shown in Figure 7.

The  $\geq 24$  GGN repeat lengths were also significantly ( $p = 0.035$ ) more frequent than the 23 GGN allele in men with penile hypospadias (69% vs. 31%) than in controls (31% vs. 54%). This difference in allele distribution was almost significant ( $p = 0.056$ ) comparing men with penile hypospadias with patients with the other two subtypes of hypospadias (32% vs. 55%).

The GGN  $\geq 24$  alleles were more frequent than the 23 GGN allele in the whole group of men with cryptorchidism (65% vs. 35%), compared with controls ( $p = 0.012$ ). The two subgroups of excryptorchid men exhibited the same pattern of GGN allele distribution, although the difference was only statistically significant comparing the excryptorchid infertile men (64% vs. 36%) with the controls ( $p = 0.049$ ). The CAG repeat lengths were not different in any of the patient groups compared with the controls.

**Table II.** Comparison of CAG and GGN repeat lengths in patients with hypospadias or cryptorchidism, and controls.

	CAG repeat		GGN repeat	
	mean (SD)	median (range)	mean (SD)	median (range)
Controls, n = 210	21.9 (3.1)	21 (12–30)	22.6 (2.4)	23 (10–25)
Cryptorchidism, n = 23	22.5 (2.5)	22 (18–29)	23.6 (0.5)	24 (23–24)*
Hypospadias, n = 51	22.2 (3.1)	22 (14–32)	23.2 (1.6)	23 (17–27)
Glanular hypospadias, n = 21	22.3 (2.6)	22 (19–29)	23.1 (1.7)	23 (17–27)
Penile hypospadias, n = 13	22.5 (4.2)	23 (14–32)	23.8 (0.8)	24 (23–26)*
Penoscrotal hypospadias, n = 17	21.8 (3.1)	21 (16–28)	22.6 (1.8)	23 (19–25)

\*  $p < 0.05$  compared with controls (Mann-Whitney  $U$  test).

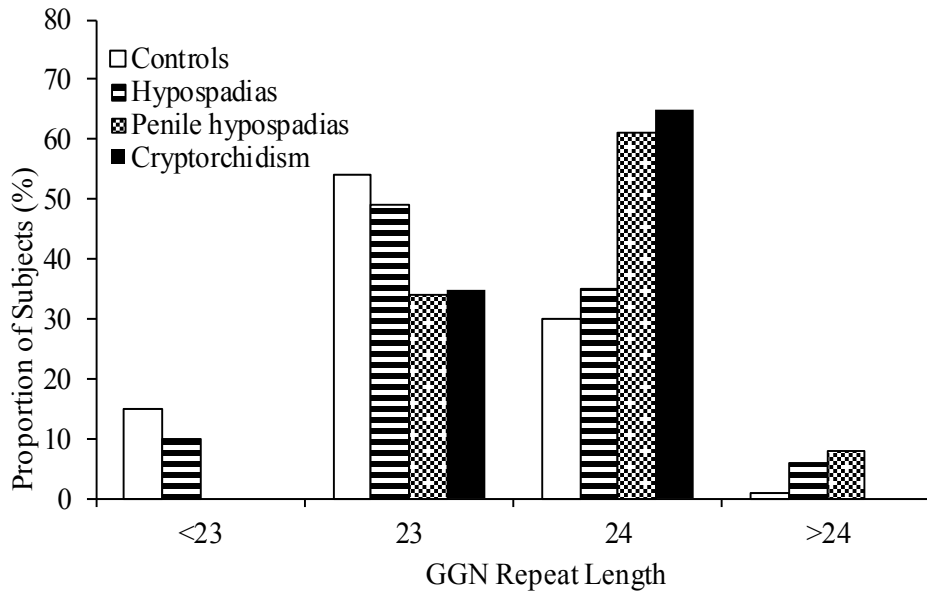

**Fig 7.** Distribution of GGN repeat lengths in controls (conscripts) and subjects with hypospadias, penile hypospadias, and cryptorchidism.

## Male subfertility and prostate cancer risk

### **Epidemiological case-control study (III)**

In study III, we found that the subfertile men were at significantly lower risk of PCa diagnosis compared with the fertile men. The principal, age-adjusted unconditional model, using all available subjects, provided an OR of 0.45 (95% CI: 0.25-0.83), and in the conditional model, using the 308 matched pairs, the OR was 0.36 (95% CI: 0.17-0.77). None of the other factors tested in the regression models significantly changed the estimates. However, having a history of UGI, was independently associated with PCa risk, with the unconditional model giving an OR of 1.54 (95% CI: 1.12-2.11), and the conditional model an OR of 1.48 (95% CI: 1.00-2.19). The multivariate models rendered results that were very similar to those of the principal analyses, and importantly the inverse association between subfertility and PCa risk was unchanged by the inclusion of UGI in the model.

### **Genetic association studies (IV and V)**

We confirmed the association between male subfertility and PCa risk in a regression analysis of the subset of men that were genotyped, OR: 0.49 (95% CI: 0.26-0.94).

In study IV the principal analysis showed that the minor alleles of the intronic SNPs rs17722841 in AHR, and rs3020449 in ESR2, and the major allele of rs7412746 in the 5'-UTR of ARNT, were positively associated with subfertility and negatively associated with fertility and PCa. The ORs obtained in an analysis of the SNP associations with subfertility only were similar in magnitude to those in the principal analysis. Finally, analysis of the FDR showed that all the nominally significant  $p$ -values of the allelic associations in the principal analysis had  $q$ -values  $>0.85$ .

In study V, the minor alleles of the following SNPs were identified in the principal analysis as significantly positively associated with subfertility and negatively associated with fertility and PCa: rs5951115 in the 5'-UTR of GSPT2, the intronic SNPs rs4430796 and rs7501939 in HNF1B, rs3093872 in the 5'-UTR of PARP2, rs3093921 (D235G) in exon 8 of PARP2, and rs33979934 (T1385S) in exon 29 of THADA. In the same analysis, a significant inverse pattern of association was found for the minor alleles of rs11765552 (M780L) in exon 11 of LMTK2, and rs1866343 in the 5'-UTR of NKX3-1. As in study IV, the ORs obtained in the analysis of the SNP associations with subfertility only were similar in magnitude to those in the principal analysis.

In study V, the two SNPs in HNF1B, rs4430796 and rs7501939, were in strong LD ( $D' = 0.98$ ,  $r^2 = 0.72$ ) in our population. The measures of LD for rs3093872 and rs3093921 in PARP2 were  $D' = 0.94$  and  $r^2 = 0.41$ , respectively. Calculation of the FDR of the allelic tests in the principal analysis showed that all associations with nominally significant  $p$ -values had  $q$ -values  $>0.50$ , except for rs3093872 in PARP2 ( $p = 0.0011$ ,  $q$ -value = 0.12).

## DISCUSSION

Our main findings regarding variation in AR gene repeat tract length and male reproductive tract function, were that carriers of the 23 GGN repeat allele had higher total testicular volume and better prostatic secretory function than carriers of the 24 GGN allele (study I). Moreover, we found that boys with penile hypospadias and cryptorchidism had longer GGN repeat tracts (median 24) than the controls (median 23, study II). However, in the entire group of hypospadias patients, as well as in glanular and penoscrotal subgroups, the median GGN repeat lengths were not significantly different compared with the controls.

These results suggest that the shorter allele is associated with better reproductive function than the longer allele. However, the associations between prostatic function and testicular volume and GGN repeat length were significant only in the infertile men, and not in the control group. One explanation is that the effect of the GGN repeat on AR transactivation capacity manifests itself phenotypically only if the androgen levels are decreased, as in the group of infertile men. Additionally, the GGN repeat may be only one of multiple factors, each contributing in small amounts to impaired reproductive function. The association may also simply represent a false positive result. On the other hand, the interpretation that the longer GGN repeat length is associated with subnormal AR function is supported by study II, as well as a later study, which found that the GGN repeat tract significantly longer in subjects with penile hypospadias and cryptorchidism compared with controls (median 24 vs. 22) [202]. Furthermore, a more recent *in vitro* study on the transactivation capacity of the AR showed superior function of the 23 glycine repeat AR compared with the other lengths, including 24 [203]. Another study found that AR protein levels were inversely affected by glycine repeat length, with the 19 repeat variant yielding significantly more AR protein than the 23 repeat variant [204]. It was suggested that hairpin stability of the RNA transcript increases with repeat length, thereby possibly interfering with translation, and accounting for the inverse relationship between GGN length and AR protein yields.

No significant differences were found between the infertile men and military conscripts with regard to the distributions of either of the repeats. Two large meta-analyses using different models for the hypothesized relationship between CAG length and risk of male infertility have been published. In a meta-analysis using a linear model, there was a slight, but significant association between increased CAG length and risk for idiopathic male infertility [205]. In the second meta-analysis [206], a non-linear model was used because a recent *in vitro* study had shown that the AR with 22 glutamine residues had higher activity than the other ARs with either 16 or 28 residues [207]. This meta-analysis showed that men with 22 or 23 CAG repeats (the commonest alleles) had a lower risk of infertility

compared with men with either longer or shorter CAG repeat tracts. Regarding the GGN repeat, the lack of significant differences in length between infertile men and fertile controls previously found in two studies [66, 151], was later corroborated in a study on Indian men [208], and in a Nigerian-German study [209], although the latter study was not race-matched. Finally, a Chilean study found no significant differences in the distribution of either CAG or GGN alleles between oligozoospermic infertile men and controls [210].

We found no association between CAG repeat lengths and cryptorchidism, thus confirming previous studies [85, 89, 202, 211]. Likewise, CAG repeat lengths were not different in hypospadiac patients compared with controls. In a previous study on boys presenting with varying degrees of undervirilized external genitalia, CAG tracts were slightly longer in those with hypospadias (of mainly penoscrotal type), than in the control group [84]. This finding has, however, not been replicated in later studies [92, 202]. At the time of doing the research, there were no publications on the association between GGN repeat length and cryptorchidism or hypospadias. Two later studies found that excryptorchid men more frequently carried the 24 GGN allele than controls, who carried shorter lengths [202, 210]. In one of these studies, the 24 GGN allele was also more common in penile hypospadias patients [202].

We divided the hypospadias patients by severity into glanular, penile and penoscrotal subtypes for two main reasons. There was, at least until recently, an underreporting of glanular hypospadias, causing a misclassification bias in any association study [88]. Additionally, the different subtypes of hypospadias have slightly different pathogenesis, since glanular hypospadias probably have a wide variety of contributing causes, possibly including fetal exposure to EDCs in susceptible individuals [88], while penoscrotal hypospadias more frequently are a feature of directly causative AR mutations (PAIS) [58]. Penile (mid-shaft) hypospadias assume an intermediary position, and are presumably also the result of “mildly” deficient androgen action, probably often together with other factors [59, 88].

Thus, the results of studies suggest that the association between CAG repeat length and the risk of cryptorchidism or hypospadias is at best very weak. Additionally, it is evident that the 24 GGN repeat allele is not directly causative of the conditions studied because it is one of the two most common alleles in the population. Nevertheless, it is possible that it contributes to the susceptibility of the disorders, in combination with other factors, during the critical time window of fetal genital development, presumably via a decrease in androgen action.

Whether these repeats, which are involved in AR function and expression, also play a role in male subfertility or PCa is widely debated, and there are now numerous publications regarding these topics. However, whether or not these

disorders could be linked was not known until 2005, when a large, national cancer registry-based Swedish study showed that childless men were at decreased risk of PCa compared with men who had fathered a child [127]. The study was not designed to differentiate between the different causes of childlessness, and did not adjust for any factors other than age or marital status. We wanted to address these shortcomings to enable us to test the hypothesis that the reduced risk of PCa observed in the childless men was a consequence of male subfertility, rather than male childlessness *per se*. We therefore performed a case-control study, which was nested in the Malmö Diet and Cancer Study (MDCS).

In the subsequent nested case-control study, undertaken as a part of this thesis, we showed that men with childlessness attributable to male-factor subfertility were at an approximately 50% lower risk of being diagnosed with PCa than were fathers of at least one biological child (study III). The binary logistic regression models were adjusted for a number of potentially confounding factors. Since our objective was to evaluate the association of, specifically, male-factor subfertility with PCa risk, we excluded men who were childless due to personal choice or lack of opportunity (and whose fertility was hence unknown). We also excluded all known cases of female-factor-dependent childlessness to ensure that the remaining cases of childlessness were attributable, at least in part, to male-factor subfertility.

Two possible misclassifications that may have introduced biases toward the null should be considered. First, it is highly likely that the childless men classified as subfertile also included some cases where the infecundity was instead caused by an undiagnosed female factor, since female-factor subfertility with no demonstrable male factor was diagnosed in a smaller proportion (12%) than expected (~30%) from estimates in other studies. Similarly, it is likely that there were undiagnosed PCa cases among the controls (who were not screened). Nevertheless, as these misclassifications potentially bias the results toward the null, the magnitude of the association would be diminished, increasing the probability of a type II error (false negative finding) rather than a type I error (false positive finding).

Our main hypothesis was that the decreased risk of PCa diagnosis in men with long-term, enduring fertility problems was a consequence of the frequently associated testicular dysfunction with concomitant hypogonadism. As discussed in paper III, concentrations of T or LH were not assessed, and we therefore lack direct data supporting our hypothesis that the subfertile men were hypogonadal (or to what degree). However, previous studies have shown that this is frequently the case [125, 126], and about 75% of subfertile patients have primary testicular failure [149]. Even if the subfertile men were not on average exposed to subnormal androgen action over their life-times compared with the fertile men, the study's main finding of an association between male subfertility and reduced PCa



risk would retain its validity, although the androgen hypothesis would need to be reassessed.

It is also possible that the subfertile men were exposed to a decreased T:E2 balance. Some previous large studies on subfertile men [125, 126], have shown increased E2 concentrations, and decreased T:E2 ratios, while others have reported decreased E2 concentrations [212, 213]. In the “European Male Aging Study”, men with primary hypogonadism or secondary hypogonadism were both found to have lower circulating E2 levels compared with eugonadal men, although the T:E2 ratios were decreased due to even larger decreases in T [214]. BMI was higher in the groups of hypogonadal men, yet this was evidently not sufficient to raise E2 levels. In the same study, men with compensated hypogonadism (normal T with increased LH) had slightly raised E2 levels, and somewhat decreased T:E2 ratios [214]. The discrepancies in E2 levels may reflect a spectrum of increasing Leydig cell dysfunction, from the partially functional Leydig cells among the subfertile men and men with compensated hypogonadism to the severely deficient Leydig cells among the men with fully-developed hypogonadism.

A decrease in the T:E2 ratio in the prostate has been hypothesized to increase the risk of prostatic carcinogenesis, due to the potentially carcinogenic influence of estrogens (especially via ER $\alpha$ -signaling) or metabolites, such as catecholestrogens [46, 47, 131]. However, it is unclear what roles the absolute concentrations (or more correctly, degree of actions) of these sex steroids play, especially with regard to possible threshold effects. Certainly, the relationship between sex steroid action and prostate carcinogenesis has not yet been fully elucidated, and the absolute levels of sex steroid action, as well as other factors, such as exposure to EDCs, may be important influences [215].

A study by Walsh *et al.* on male subfertility and PCa risk was recently published that used a cohort linked to the United States SEER (Surveillance, Epidemiology, and End Results) program of the National Cancer Institute [216]. The subgroup of men diagnosed with male factor infertility were reported to be at a slightly increased risk of high-grade (Gleason score 8-10) PCa, standardized incidence ratio (SIR): 1.3 (95% CI, 1.0-1.7), while the risk of all grades of PCa was unchanged in the entire group of men who had been evaluated for infertility (SIR): 0.9 (95% CI, 0.8-1.1). When analyzed using an age- and fertility-treatment adjusted Cox regression model, the hazard ratio (HR) for any PCa for men with male factor infertility compared with those without male-factor infertility was 1.8 (95% CI, 1.2-2.5). Using the same methodology, the HR of high-grade PCa in men with male factor infertility was 2.6 (95% CI, 1.4-4.8).

In contrast, our study did not show any significant differences in tumor grade in the subfertile men compared with the fertile men, although the proportion of high-grade tumors (Gleason score 8-10) among the subfertile men was non-significantly

larger. It cannot be excluded that subfertile men with chronic hypogonadism who develop PCa more frequently develop high-grade tumors due to selection of less androgen-dependent cancer cells. Indeed, there is some evidence from other studies that men exposed to low intraprostatic androgen levels may be at increased risk of high-grade PCa [217]. Cancer-related mortality would hence be higher in these men, potentially introducing a differential bias into the study which would inflate the magnitude of the association. Even if male infertility is associated with an increased risk of high-grade PCa, and hence mortality, the findings of the previous large-scale national cancer registry-based studies which included entire birth cohorts [127, 128], suggest that the result in our study is not purely artifactual, although it cannot be excluded that the magnitude of the association is exaggerated.

The study by Walsh *et al.* was not directly comparable to ours due to different methodology, and there were also several limitations that should be noted. The study was conducted in California, but the groups of infertile and fertile men were not race-matched, which is needed for genetic, life-style-related and socio-economic reasons. The mean age at diagnosis of PCa (or last-follow-up) for men with male-factor infertility was 50.1 years, and for men with male-factor negative infertility 48.4 years, whereas the men in our study were substantially older at diagnosis at 67.6 years. Furthermore, the proportion of high grade tumors was 27% among all men diagnosed with PCa in the entire cohort of men with male-factor negative, positive or unknown fertility status. The proportion of high-grade tumors among the men with male-factor infertility was 19/56 (34%), and among the men without male-factor infertility 16/64 (25%). Accordingly, high-grade tumors were considerably more common in both groups than among the men in our study. However, as discussed above, the exclusion of deceased men from our study may have introduced a bias that would contribute to the disparities between studies regarding both tumor aggressiveness and age at diagnosis. Additionally the trend toward assigning higher Gleason grades to diagnostic prostate biopsies may have started earlier in the USA than in Sweden, and the conversion procedure from WHO grade to Gleason score in the SEER data may have classified too many tumors as Gleason score 8-10. In our, Gleason scores were retrospectively assessed if they were unavailable.

Moreover, in the study by Walsh *et al.*, person-years at risk were measured from the date of fertility evaluation to the date of diagnosis of PCa, providing a short median lag time of 9 years for men with no male factor and 10 years for men with male factor infertility. It is plausible that many of the men diagnosed with infertility had been subfertile due to testicular dysfunction for a long period before their evaluation, meaning that exposure times were underestimated. Additionally, the number of children the men sired was not considered, suggesting that the average degree of subfertility may have been less severe than in our study, in which only men who had never fathered a child, even though they had actively

tried, were defined as subfertile. The study design hence represents an implicit hypothesis that in effect is different from ours.

Thus, the results of the study by Walsh *et al.* are not fully comparable with ours for the several reasons discussed above. However, we cannot exclude that the subfertile men in our study were perhaps also at increased risk of high-grade PCa, but that it was not detected due to smaller study size, and possibly also due to an under-inclusion of patients with high grade disease. The mechanism proposed by Walsh *et al.* that defective DNA repair may be a link between male infertility and risk of high-grade PCa [216] is compatible with their findings, but does not necessarily exclude the possibility hypogonadism may (also) have played a role in promoting the selection of less androgen-dependent, high-grade tumors.

We concluded that the two national cancer-registry-based studies [127, 128], and our nested case-control study corroborate the hypothesis that the decreased risk of PCa in men with enduring subfertility is a consequence of chronically disturbed sex steroid action secondary to testicular dysfunction, and hypothesized that genetic factors may play a role in linking the disorders. We subsequently carried out a candidate gene study, selecting genes in accordance with the etiological hypothesis (study IV). Additionally, since fetal exposure to EDCs has been associated with testicular dysfunction and prostatic diseases in adulthood, we were interested in investigating the AHR pathway, since it is a direct mediator of certain EDCs, and also because it interacts with and modulates the sex steroid signaling pathways.

The principal analysis identified alleles in the AHR, ARNT and ESR2 genes that were both positively associated subfertility and negatively associated with PCa risk. The associations in the secondary analysis were of similar magnitudes, although of only borderline significance for AHR and ESR2. These results hence led us to tentatively infer that the genes may play a role in linking male subfertility with reduced PCa risk indirectly via their associations with impaired reproductive function. We therefore conclude that the results are in support of the hypothesis that alterations in sex steroid action, potentially via interaction with the AHR-ARNT signaling pathway, may contribute to the overall reduction in PCa risk in subfertile men.

As the results suggest a possible influence of exposure to EDCs on the joint risks of subfertility and PCa, it may be of interest to assess the effects of interaction between exposure and genotype. Such an undertaking would presumably be prohibitively difficult, since it would ideally take the form of a very long-term prospective cohort study which would start with the collection of maternal EDC exposure data, and continue with follow-up at least until PCa is diagnosed half a century or more later. Other prohibitive factors include the difficulty in attaining a sufficient sample size and assessing the exposure to all pertinent EDCs, as well as

---

the exposure to other potentially contributing factors. Furthermore, the effects of EDCs are notoriously difficult to predict, as they are presumably dependent on the mix of substances, the timing of exposure, individual genetic susceptibility, and the complexity of the interactions of the network of signaling pathways that are activated or inhibited.

We subsequently widened the scope of our exploration of the possible genetic contribution to the association between male subfertility and PCa risk because previous GWAS and candidate gene studies on PCa risk had identified a number of risk loci implicating genes not directly involved in the sex steroid or AHR signaling pathways (study V). In light of these findings, we hypothesized that certain genes previously linked to PCa risk may harbor SNPs associated with the risk of subfertility, and conversely that the genes PARP1 and PARP2, which have previously been associated with subfertility-related phenotypes, may also harbor alleles associated with PCa risk.

The principal analysis revealed that polymorphisms in PARP2, GSPT2, HNF1B, LMTK2, NKX3-1, and THADA were both positively associated subfertility and negatively associated with PCa risk. The association with PARP2 was particularly robust, indicated both by a low *p*-value and a low *q*-value. The associations in the secondary analysis were of similar magnitudes, although of only borderline significance for all SNPs except for the two in PARP2. The possible roles of the identified genes in linking male subfertility with PCa risk are discussed in detail in paper V, and will therefore not be discussed further here.

The results in both studies IV and V are based on a relatively small number of subfertile men, increasing the rate of type II errors (false negatives) due to limited power. However, the ethnic homogeneity and limited geographical distribution of the population is somewhat compensatory. Nevertheless, the FDR analysis revealed that most associations (except for that of rs3093872 in PARP2) have a high probability of being type I errors (false positives), and the alleles identified in both studies therefore need to be validated by replication in a larger material.



## SUMMARY AND CONCLUSIONS

The overarching aim of this thesis was to investigate the possible epidemiological and genetic associations between deficient androgen action (hypogonadism) and disorders of the male reproductive tract. The purpose of the first two publications was to investigate the possible associations between variation in the lengths of the GGN and CAG codon repeats and disorders of the male reproductive tract, including genital malformations, while the objective of the three following papers was to study the possible epidemiological and genetic associations between prostate cancer (PCa) and male subfertility as a proxy indicator of long-term testicular dysfunction, and hence hypogonadism.

Study I suggests that the <21 CAG/23 GGN repeat haplotype may be associated with a lower risk of infertility than haplotypes consisting of alleles with longer CAG or GGN repeat lengths. The results also suggest that the 23 GGN repeat allele is associated with better reproductive function than the 24 GGN repeat allele, as evidenced by the larger total testicular volume and better prostatic secretory function among the carriers of the shorter allele. However, the associations between the GGN alleles and reproductive endpoints were only significant in the group of infertile men, and not in the young military conscripts. One possible explanation is that the effect of the GGN repeat on AR transactivation capacity manifests itself phenotypically only if the androgen levels are decreased, as in the group of infertile men. Additionally, the GGN repeat may be only one of multiple deleterious factors, each contributing in small amounts to impaired reproductive function. Study II supports the interpretation that longer GGN repeat lengths are associated with subnormal AR function, since both patients with penile hypospadias and patients with a history of cryptorchidism had longer GGN repeat tracts (median 24) than the controls (median 23).

The nested case-control study (paper III) suggests that subfertile childless men are at an approximately 50% lower risk of being diagnosed with PCa than are fathers of at least one biological child. We excluded cases of childlessness related to personal choice or female infertility, and adjusted the analysis for a number of potentially confounding factors. Study IV indicates that variants in the AHR, ARNT and ESR2 genes may play a role in indirectly linking male subfertility with reduced PCa risk through their associations with impaired reproductive function. These results hence support the hypothesis that alterations in sex steroid action, potentially via interaction with the AHR-ARNT signaling pathway, may contribute to the overall reduction in PCa risk in subfertile men. The results of study V imply that certain alleles in PARP2, GSPT2, HNF1B, LMTK2, NKX3-1, and THADA may also contribute to the reduction in PCa risk observed in subfertile men, via their associations with impaired reproductive function. The association with PARP2 was particularly robust. Replication of the genetic

associations in a larger validation study would warrant further investigation of the functions of several of the identified genes in this context.

Thus, the studies suggest that longer AR gene GGN repeat tracts may decrease the receptor's activity, increasing the risk of androgen-related genital malformations in susceptible males, and that subfertile childless men are at reduced risk of PCa, which we hypothesize may be a consequence of chronic, poor gonadal function, and hence decreased androgen action over the lifespan. Additionally, several genetic variants, as well as possibly fetal exposure to EDCs, may play a role in linking the two disorders, primarily through their associations with impaired reproductive function.

---

## FUTURE PERSPECTIVES

Studies I and II on the associations between GGN repeat length and male reproductive function and disorders of the male reproductive tract have over the years been followed by numerous other clinical and *in vitro* studies. Future *in vitro* studies could expand the work of Lundin, *et al.* (2007) [203], of the effects on AR transactivation function of variation in polyglycine (GGN) length within the normal range, both with and without variation in the length of the polyglutamine (CAG) repeat. Another property of the AR transactivation function that could be investigated is whether the interaction with AR cofactors is affected by variation in the lengths of the codon repeats.

The finding in study III of an association between male subfertility-related childlessness and PCa risk needs to be replicated in a much larger material with more precisely defined phenotypes. The ideal case-control study would be at least an order of magnitude larger in size, and the reproductive function of the participants would have been evaluated in detail in youth. Such an evaluation would include measures of sperm and semen parameters as well as serum concentrations of the reproductive hormones. Of equal importance, the men defined as being PCa-free would be confirmed as such through multiple prostate biopsies. Additional factors may also be considered as potential confounders, especially diabetes mellitus, which has been shown to be associated with reduced PCa risk in previous studies. A replicated result in such an ideal nested case-control study would corroborate our findings and also enable a more detailed and accurate analysis of the relationship between male subfertility, testicular dysfunction and PCa risk. The most powerful study design is, of course, a large-scale, very long-term, prospective longitudinal cohort study, although conducting such a study may not be feasible in most settings due to the very long-term (multi-decade) aspect and high costs involved.

The genetic variants identified as possibly linking male subfertility with reduced PCa risk in studies IV and V need to be replicated in a larger material, and upon validation could then be investigated in laboratory experiments to try to elucidate the mechanisms by which they might link subfertility with PCa risk. Another possible avenue of research is to study the potential modulating effects of variation in some of the identified genes on the effects of exposure to EDCs with dioxin-like or estrogenic or anti-estrogenic action. Finally, the possibility that epigenetic modifications are also involved in linking male subfertility with PCa, has not been evaluated in the present thesis, and hence remains to be probed.

A deeper understanding of the possible hereditary factors linking male subfertility with PCa risk may contribute to understanding the pathogenesis of PCa, and ultimately improve the treatment of both disorders.





## POPULÄRVETENSKAPLIG SAMMANFATTNING

De manliga könshormonerna, sk. androgener, spelar en nyckelroll under fosterutvecklingen av de manliga inre (t ex. blåshalskörtel/prostata) och yttre (t ex. penis) könsorganen. Androgenerna stimulerar även tillväxten av desamma under puberteten samt upprätthåller de manliga kroppsegenskaperna under vuxenlivet. De två huvudsakliga androgenerna är testosteron (T) samt  $5\alpha$ -dihydrotestosteron (DHT), vilka verkar genom att binda till den sk. androgenreceptorn (AR), som är en transkriptionsfaktor, innebärande att dess funktion är att slå på eller av andra gener.

Om inte AR fungerar korrekt blir resultatet en dålig ”signalöverföring”, vilket yttrar sig i olika grader av okänslighet för androgenernas funktioner. Patienter som föds med en helt icke-funktionell AR pga. en genmutation har ett tillstånd som kallas komplett androgeninsensitivitetssyndrom (CAIS). Eftersom en fungerande AR är central för att det ”manliga utvecklingsprogrammet” ska slås på under fosterutvecklingen, yttrar sig syndromet genom att ett barn med manlig kromosom-uppsättning föds med en flickas kropp, sk. feminisering. Det förekommer även mildare varianter av feminisering, t ex. att pojken föds med en penis som kan vara mindre än normalt, och som inte sällan har urinrörsmynningen för nära penisroten, sk. hypospadi. Ibland har testiklarna inte vandrat ned i pungen, sk. retentio testis eller kryptorkism, och finns istället i buken eller i ljumskarna.

AR-genen ligger på X-kromosomen, vilket innebär att män endast har en kopia av genen, medan kvinnor har två. Detta betyder att ev. skadliga genmutationer som gör att AR proteinet inte fungerar oftast drabbar män, men inte kvinnor som har en ”reservgen” på den andra X-kromosomen. Som alla andra sk. kodande gener består AR-genen av en sekvens med DNA-baser, där tre stycken baser utgör ett sk. kodon, som kodar för en aminosyra. Vilken aminosyra som kodonet ”översätts” till avgörs av kodonets bassekvens. I AR-genen finns två sträckor med repeterande kodon som upprepas i varierande antal, sk. repeat. Antalet repeat varierar normalt mellan olika individer och påverkar AR-funktionen. AR-repeaten är CAG, som kodar för aminosyran glutamin, respektive GGN, som kodar för glycin.

När jag började arbeta med forskningsprojektet som denna avhandling baseras på hade man i viss utsträckning studerat sambandet mellan variationer i CAG-repeat längd och olika sjukdomstillstånd eller missbildningar i de manliga könsorganen. Däremot fanns endast mycket begränsad information om GGN-repeatets ev. betydelse i dessa avseenden. Vi ville därför testa hypotesen att variationer i GGN-repeatets längd ev. kunde påverka AR funktionen, och därmed även individens risk för att drabbas av sjukdomstillstånd i de manliga könsorganen.

Den första i avhandlingen ingående studien visade att en grupp med mönstrande unga män (som representerar en genomsnittliga manlig befolkning) oftare än

infertila (ofruktsamma) män var bärare av korta (<21) CAG repeat i kombinationen med den vanligaste GGN längden på 23 repeat. Vi fann även att den kortare GGN varianten var förknippad med bättre reproduktiv funktion, genom att bärarna hade större genomsnittlig testikelvolym och bättre prostatisk sekretorisk funktion än bärare av den längre varianten. I andra studien fann vi att den längre GGN längden var vanligare hos män med sk. penila hypospadier och retentio testis. Sammantaget talar studieresultaten för att genvarianten med 23 GGN repeat verkar vara förknippad med bättre AR funktion än den med 24 repeat.

I de sista tre studierna utforskade vi det ev. sambandet mellan ofrivillig barnlöshet beroende på manlig subfertilitet och risken för prostatacancer (PCa). Tredje studien var en epidemiologisk fallkontrollstudie, vars syfte var att testa hypotesen att barnlösa subfertila män löper lägre risk att drabbas av PCa än fertila män, då de förstnämnda ofta har nedsatt testikelfunktion och därmed lägre androgenhalter i kroppen än normalt (sk. hypogonadism). Man vet sedan tidigare att androgener är inblandade i PCa-utveckling. I de två sista studierna ville vi undersöka om varianter (sk. polymorfier) i vissa gener ev. kunde vara delaktiga i att länka samman manlig subfertilitet med nedsatt risk för PCa.

Fallkontrollstudien indikerar att subfertila ofrivilligt barnlösa män löper en ungefär halverad risk att diagnostiseras med PCa än fäder med minst ett biologiskt barn. I vår analys kontrollerade vi att sambandet inte i själva verket berodde på sk. störfaktorer. I fjärde studien undersöktes genetiska varianter i signalerings-systemen som medierar androgeners och östrogeners (kvinnliga könshormoner) effekter, samt även i den sk. arylhydrocarbonreceptorn (AHR) och i samverkande proteiner, t ex. ARNT. AHR medierar effekterna av vissa ämnen i miljön med hormonliknande, eller ibland giftiga, effekter (s.k. endokrina disruptorer). Vi fann att varianter i AHR, ARNT samt östrogenreceptor beta (ESR2) ev. kunde bidra till att länka samman manlig subfertilitet med minskad risk för PCa. Resultaten stödjer hypotesen att ändringar i könshormonernas verkan ev. kan bidra till den minskade risken för PCa hos de subfertila männen. I femte studien undersöktes varianter i gener som pekats ut som PCa-riskgener i tidigare studier, eller i vissa fall som tidigare visats spela roll för fertiliteten. Studien visade att polymorfier i ett flertal andra gener ev. också bidrar till att minska risken för PCa bland subfertila män. Ett av de statistiskt starkaste sambanden var med en gen som kallas PARP2, som är inblandad i ett flertal viktiga funktioner såsom cellöverlevnad och celldöd, och som även är inblandad i spermienbildningen.

Sammanfattningsvis är våra konklusioner följande: längre GGN-repeatlängder kan vara förknippade med försämrad fertilitet och ökad risk för kryptorkism och hypospadier; subfertila ofrivilligt barnlösa män löper en ca 50% lägre risk att drabbas av PCa än fäder med minst ett biologiskt barn, samt; varianter i ett flertal gener kan ev. vara inblandade i att länka samman manlig subfertilitet med nedsatt PCa-risk genom deras samband med nedsatt reproduktionsfunktion.

## ACKNOWLEDGEMENTS

The research in this thesis was supported by grants from the Swedish Research Council, the Swedish Cancer Society, the Malmö University Hospital Foundation for Cancer Research, the Gunnar Nilsson Cancer Fund, the Ernhold Lundström Foundation, the Einar and Inga Nilsson Foundation, the Crafoord Foundation, the Mossfelt Foundation, Ove Tulefjord's Fund, and the Foundation for Urological Research.

Lund University and Region Skåne have bestowed grants (FoU and ALF) that have enabled me to devote significant amounts of time to this project, which was carried out at the Reproductive Medicine Centre at Skåne University Hospital in Malmö. This thesis is the result of the contributions of a large number of people, to whom I am very grateful.

I especially wish to thank my head supervisor, Yvonne Giwercman, for guiding me through this undertaking with continuous encouragement and kindness, and for introducing me to the world of andrological laboratory research. Your knowledge about and enthusiasm for molecular biology and genetics have undoubtedly whetted my appetite for trying to gain a deeper understanding of their workings and clinical relevance.

I also want to express my sincere gratitude to my co-supervisor, Aleksander Giwercman, for supporting this endeavor with never-ending enthusiasm, vision and patience. Your drive and passion for research in the field of reproductive medicine are quite remarkable, as your prompt processing of e-mails at seemingly any time of day (and night) is testimony to!

All of my co-authors have of course also been vital; without you this thesis would not have existed: Kristina Lundin, Elin Aschim, David Ulmert, Lars Rylander, Anders Bjartell, Jonas Manjer, Göran Berglund, Christer Halldén, Marianne Willén, Agneta Nordenskjöld, Trine Haugen, and Tom Grotmol. Your contributions to the work, your opinions and ideas, and your support are all greatly appreciated. Additionally, Peter Wallström and Anders Dahlin deserve credit for helping out with the collection of extra clinical information and for extracting data from the MDCS database.

Jonatan, I think you sparked my interest in this area of research when you brought up the topic of environmental pollutants and effects on wildlife and humans. Presumably neither of us foresaw what might come of the "small" projects we started out with for our 5<sup>th</sup> year FÖS-projects.

I thank David, Jens, Yvonne, Adam, Charlotta, Åke, Camilla, Charlotte B, Charlotte G, and the many other people whom I got to know during my stay in the

Wallenberg Laboratory for the good-humored atmosphere and the interesting discussions.

I had the pleasure of getting to know Saad, Jonas, Patrik, Olof, Jakob, Marcello, Juris, Tarmo, and many more friendly and funny people at the old “Fertility Centre”. You all gave the research group its distinctive character in its various “incarnations”. Jonas, I’ve been reminded more than once of the time I unthinkingly borrowed your comfortable pillow (with your embroidered initials) during our kick-off in Ystad. I’m pretty sure you think the mistake was as awkwardly comical as the rest of us!

What would research life be without all the people, past and present, whom I have met during my time at CRC and RMC including Nishtman, Leon, Hannah, Christel, Hamideh, Leif, Mona, Tamae, Paal-André, Carl-Magnus, Kalle, Linus, Ida, Anna-Karin, Karolina, Sigrid, and Johannes. You all make the lab an enjoyable place to be thanks to your good sense of humor, friendliness and laughs. Kris and Giuseppe, you are appreciated for making it a mite easier to get a table at di Penco at lunchtime, and for turning many a meal there into a source of amusement (thanks to both the Italian atmosphere and the often comical conversations)!

I am thankful to Per-Anders Abrahamsson, head of the Department of Urology at Skåne University Hospital Malmö, for approving my absence from the clinic during my periods of research, and to all my other colleagues and friends there who help make work rewarding. Helen Karlsson, Anki Rosberg and Åsa Thuning are appreciated for always kindly assisting me in administrative matters.

I am also grateful to all the individuals who volunteered to take part in the studies, making this research possible.

Finally, my warmest thanks go to my friends and relatives for encouragement and enriching life, my father Hassan and my mother Irène for always supporting me, my nephew Elias for inventing games with ad hoc rules, and my sister Theresa and my brother Samir for invaluable friendship throughout the years.

---

**REFERENCES**

1. Wilson JD, Roehrborn C. Long-term consequences of castration in men: lessons from the Skoptzy and the eunuchs of the Chinese and Ottoman courts. *J Clin Endocrinol Metab.* 1999;84:4324-31.
2. van der Meer T. Eugenic and sexual folklores and the castration of sex offenders in the Netherlands (1938-1968). *Studies in history and philosophy of biological and biomedical sciences.* 2008;39:195-204.
3. Brown-Séquard C-É. NOTE ON THE EFFECTS PRODUCED ON MAN BY SUBCUTANEOUS INJECTIONS OF A LIQUID OBTAINED FROM THE TESTICLES OF ANIMALS. *The Lancet.* 1889;134:105-7.
4. Butenandt A, Hanisch G. Über Testosteron. Umwandlung des Dehydroandrosterons in Androstendiol und Testosteron; ein Weg zur Darstellung des Testosterons aus Cholesterin. *Hoppe-Seyler's Zeitschrift für physiologische Chemie.* 1935;237:89-97.
5. Ruzicka L, Wettstein A. Sexualhormone VII. Über die künstliche Herstellung des Testikelhormons Testosteron (Androsten-3-on-17-ol). *Helvetica Chimica Acta.* 1935;18:1264-75.
6. Burkhardt EZ. A study of the effects of androgenic substances in the rat by the aid of colchicine [Ph D]: University of Chicago; 1940.
7. Huggins C, Hodges CV. Studies on Prostatic Cancer. I. The Effect of Castration, of Estrogen and of Androgen Injection on Serum Phosphatases in Metastatic Carcinoma of the Prostate. *Cancer Research.* 1941;1:293-7.
8. Imperato-McGinley J, Guerrero L, Gautier T, Peterson RE. Steroid 5alpha-reductase deficiency in man: an inherited form of male pseudohermaphroditism. *Science.* 1974;186:1213-5.
9. Zhu YS, Imperato-McGinley JL. 5alpha-reductase isozymes and androgen actions in the prostate. *Ann N Y Acad Sci.* 2009;1155:43-56.
10. Marks LS, Mostaghel EA, Nelson PS. Prostate tissue androgens: history and current clinical relevance. *Urology.* 2008;72:247-54.
11. Gormley GJ, Stoner E, Bruskewitz RC, Imperato-McGinley J, Walsh PC, McConnell JD, et al. The effect of finasteride in men with benign prostatic hyperplasia. The Finasteride Study Group. *N Engl J Med.* 1992;327:1185-91.

12. Thompson IM, Goodman PJ, Tangen CM, Lucia MS, Miller GJ, Ford LG, et al. The influence of finasteride on the development of prostate cancer. *N Engl J Med.* 2003;349:215-24.
13. Morris JM. The syndrome of testicular feminization in male pseudohermaphrodites. *American journal of obstetrics and gynecology.* 1953;65:1192-211.
14. Quigley CA, De Bellis A, Marschke KB, el-Awady MK, Wilson EM, French FS. Androgen receptor defects: historical, clinical, and molecular perspectives. *Endocr Rev.* 1995;16:271-321.
15. Bowen P, Lee CS, Migeon CJ, Kaplan NM, Whalley PJ, McKusick VA, et al. Hereditary Male Pseudohermaphroditism with Hypogonadism, Hypospadias, and Gynecomastia: Reifenstein's Syndrome. *Annals of internal medicine.* 1965;62:252-70.
16. Toppari J, Larsen JC, Christiansen P, Giwercman A, Grandjean P, Guillette LJ, Jr., et al. Male reproductive health and environmental xenoestrogens. *Environmental health perspectives.* 1996;104 Suppl 4:741-803.
17. Sharpe RM, Skakkebaek NE. Are oestrogens involved in falling sperm counts and disorders of the male reproductive tract? *Lancet.* 1993;341:1392-5.
18. Peng X, Zeng X, Peng S, Deng D, Zhang J. The association risk of male subfertility and testicular cancer: a systematic review. *PLoS One.* 2009;4:e5591.
19. Skakkebaek NE, Rajpert-De Meyts E, Main KM. Testicular dysgenesis syndrome: an increasingly common developmental disorder with environmental aspects. *Hum Reprod.* 2001;16:972-8.
20. Summers K, Crespi B. The androgen receptor and prostate cancer: a role for sexual selection and sexual conflict? *Medical hypotheses.* 2008;70:435-43.
21. Hameed S, Jayasena CN, Dhillon WS. Kisspeptin and fertility. *J Endocrinol.* 2011;208:97-105.
22. Nicol L, McNeilly JR, Stridsberg M, McNeilly AS. Differential secretion of gonadotrophins: investigation of the role of secretogranin II and chromogranin A in the release of LH and FSH in LbetaT2 cells. *Journal of molecular endocrinology.* 2004;32:467-80.
23. Finkelstein JS, O'Dea LS, Whitcomb RW, Crowley WF, Jr. Sex steroid control of gonadotropin secretion in the human male. II. Effects of estradiol

- administration in normal and gonadotropin-releasing hormone-deficient men. *J Clin Endocrinol Metab.* 1991;73:621-8.
24. Hayes FJ, Seminara SB, Decruz S, Boepple PA, Crowley WF, Jr. Aromatase inhibition in the human male reveals a hypothalamic site of estrogen feedback. *J Clin Endocrinol Metab.* 2000;85:3027-35.
  25. Hedger MP, Winnall WR. Regulation of activin and inhibin in the adult testis and the evidence for functional roles in spermatogenesis and immunoregulation. *Mol Cell Endocrinol.* 2011.
  26. Jarow JP, Zirkin BR. The androgen microenvironment of the human testis and hormonal control of spermatogenesis. *Ann N Y Acad Sci.* 2005;1061:208-20.
  27. Verhoeven G, Willems A, Denolet E, Swinnen JV, De Gendt K. Androgens and spermatogenesis: lessons from transgenic mouse models. *Philos Trans R Soc Lond B Biol Sci.* 2010;365:1537-56.
  28. Svechnikov K, Izzo G, Landreh L, Weisser J, Soder O. Endocrine disruptors and Leydig cell function. *J Biomed Biotechnol.* 2010;Article ID 684504:10 pages, 2010.
  29. Plant TM. Undifferentiated primate spermatogonia and their endocrine control. *Trends in endocrinology and metabolism: TEM.* 2010;21:488-95.
  30. Walters KA, Simanainen U, Handelsman DJ. Molecular insights into androgen actions in male and female reproductive function from androgen receptor knockout models. *Hum Reprod Update.* 2010;16:543-58.
  31. Carreau S, Hess RA. Oestrogens and spermatogenesis. *Philos Trans R Soc Lond B Biol Sci.* 2010;365:1517-35.
  32. Kumar TR. What have we learned about gonadotropin function from gonadotropin subunit and receptor knockout mice? *Reproduction.* 2005;130:293-302.
  33. Vezina CM, Lin TM, Peterson RE. AHR signaling in prostate growth, morphogenesis, and disease. *Biochem Pharmacol.* 2009;77:566-76.
  34. Cunha GR, Ricke W, Thomson A, Marker PC, Risbridger G, Hayward SW, et al. Hormonal, cellular, and molecular regulation of normal and neoplastic prostatic development. *J Steroid Biochem Mol Biol.* 2004;92:221-36.
  35. Taylor RA, Toivanen R, Risbridger GP. Stem cells in prostate cancer: treating the root of the problem. *Endocr Relat Cancer.* 2010;17:R273-85.



36. Goldstein AS, Stoyanova T, Witte ON. Primitive origins of prostate cancer: in vivo evidence for prostate-regenerating cells and prostate cancer-initiating cells. *Molecular oncology*. 2010;4:385-96.
37. Wang X, Kruithof-de Julio M, Economides KD, Walker D, Yu H, Halili MV, et al. A luminal epithelial stem cell that is a cell of origin for prostate cancer. *Nature*. 2009;461:495-500.
38. Wang ZA, Shen MM. Revisiting the concept of cancer stem cells in prostate cancer. *Oncogene*. 2011;30:1261-71.
39. Risbridger GP, Taylor RA. The complexities of identifying a cell of origin for human prostate cancer. *Asian J Androl*. 2011;13:118-9.
40. Bowen C, Gelmann EP. NKX3.1 activates cellular response to DNA damage. *Cancer Res*. 2010;70:3089-97.
41. Costello LC, Franklin RB. The clinical relevance of the metabolism of prostate cancer; zinc and tumor suppression: connecting the dots. *Molecular cancer*. 2006;5:17.
42. Robert M, Gibbs BF, Jacobson E, Gagnon C. Characterization of prostate-specific antigen proteolytic activity on its major physiological substrate, the sperm motility inhibitor precursor/semenogelin I. *Biochemistry*. 1997;36:3811-9.
43. Robert M, Gagnon C. Semenogelin I: a coagulum forming, multifunctional seminal vesicle protein. *Cell Mol Life Sci*. 1999;55:944-60.
44. Niu Y, Chang TM, Yeh S, Ma WL, Wang YZ, Chang C. Differential androgen receptor signals in different cells explain why androgen-deprivation therapy of prostate cancer fails. *Oncogene*. 2010;29:3593-604.
45. Simanainen U, Allan CM, Lim P, McPherson S, Jimenez M, Zajac JD, et al. Disruption of prostate epithelial androgen receptor impedes prostate lobe-specific growth and function. *Endocrinology*. 2007;148:2264-72.
46. Ellem SJ, Risbridger GP. Aromatase and regulating the estrogen:androgen ratio in the prostate gland. *J Steroid Biochem Mol Biol*. 2010;118:246-51.
47. Ho SM, Lee MT, Lam HM, Leung YK. Estrogens and prostate cancer: etiology, mediators, prevention, and management. *Endocrinology and metabolism clinics of North America*. 2011;40:591-614.
48. Kashimada K, Koopman P. Sry: the master switch in mammalian sex determination. *Development*. 2010;137:3921-30.

49. Rey RA, Grinspon RP. Normal male sexual differentiation and aetiology of disorders of sex development. *Best Pract Res Clin Endocrinol Metab.* 2011;25:221-38.
50. Biason-Lauber A. Control of sex development. *Best Pract Res Clin Endocrinol Metab.* 2010;24:163-86.
51. Stukenborg JB, Colon E, Soder O. Ontogenesis of testis development and function in humans. *Sex Dev.* 2010;4:199-212.
52. Sajjad Y. Development of the genital ducts and external genitalia in the early human embryo. *The journal of obstetrics and gynaecology research.* 2010;36:929-37.
53. Rey RA, Musse M, Venara M, Chemes HE. Ontogeny of the androgen receptor expression in the fetal and postnatal testis: its relevance on Sertoli cell maturation and the onset of adult spermatogenesis. *Microsc Res Tech.* 2009;72:787-95.
54. Bay K, Andersson AM. Human testicular insulin-like factor 3: in relation to development, reproductive hormones and andrological disorders. *Int J Androl.* 2011;34:97-109.
55. Staack A, Donjacour AA, Brody J, Cunha GR, Carroll P. Mouse urogenital development: a practical approach. *Differentiation.* 2003;71:402-13.
56. Hannema SE, Hughes IA. Regulation of Wolffian duct development. *Hormone research.* 2007;67:142-51.
57. Timms BG. Prostate development: a historical perspective. *Differentiation.* 2008;76:565-77.
58. van der Werff JF, Nievelstein RA, Brands E, Luijsterburg AJ, Vermeij-Keers C. Normal development of the male anterior urethra. *Teratology.* 2000;61:172-83.
59. Werner R, Grotsch H, Hiort O. 46,XY disorders of sex development--the undermasculinised male with disorders of androgen action. *Best Pract Res Clin Endocrinol Metab.* 2010;24:263-77.
60. Chang CS, Kokontis J, Liao ST. Structural analysis of complementary DNA and amino acid sequences of human and rat androgen receptors. *Proc Natl Acad Sci U S A.* 1988;85:7211-5.
61. Lubahn DB, Joseph DR, Sar M, Tan J, Higgs HN, Larson RE, et al. The human androgen receptor: complementary deoxyribonucleic acid cloning,

- sequence analysis and gene expression in prostate. *Mol Endocrinol.* 1988;2:1265-75.
62. Bennett NC, Gardiner RA, Hooper JD, Johnson DW, Gobe GC. Molecular cell biology of androgen receptor signalling. *The international journal of biochemistry & cell biology.* 2010;42:813-27.
  63. Heemers HV, Tindall DJ. Androgen receptor (AR) coregulators: a diversity of functions converging on and regulating the AR transcriptional complex. *Endocr Rev.* 2007;28:778-808.
  64. Zitzmann M. The role of the CAG repeat androgen receptor polymorphism in andrology. *Frontiers of hormone research.* 2009;37:52-61.
  65. Gao T, Marcelli M, McPhaul MJ. Transcriptional activation and transient expression of the human androgen receptor. *J Steroid Biochem Mol Biol.* 1996;59:9-20.
  66. Lundin KB, Giwercman A, Richthoff J, Abrahamsson PA, Giwercman YL. No association between mutations in the human androgen receptor GGN repeat and inter-sex conditions. *Mol Hum Reprod.* 2003;9:375-9.
  67. Kittles RA, Young D, Weinrich S, Hudson J, Argyropoulos G, Ukoli F, et al. Extent of linkage disequilibrium between the androgen receptor gene CAG and GGC repeats in human populations: implications for prostate cancer risk. *Human genetics.* 2001;109:253-61.
  68. McEvoy BP, Powell JE, Goddard ME, Visscher PM. Human population dispersal "Out of Africa" estimated from linkage disequilibrium and allele frequencies of SNPs. *Genome Res.* 2011;21:821-9.
  69. La Spada AR, Wilson EM, Lubahn DB, Harding AE, Fischbeck KH. Androgen receptor gene mutations in X-linked spinal and bulbar muscular atrophy. *Nature.* 1991;352:77-9.
  70. Kumar R, Atamna H, Zakharov MN, Bhasin S, Khan SH, Jasuja R. Role of the androgen receptor CAG repeat polymorphism in prostate cancer, and spinal and bulbar muscular atrophy. *Life sciences.* 2011;88:565-71.
  71. Hughes IA, Houk C, Ahmed SF, Lee PA. Consensus statement on management of intersex disorders. *Journal of pediatric urology.* 2006;2:148-62.
  72. Thyen U, Lanz K, Holterhus PM, Hiort O. Epidemiology and initial management of ambiguous genitalia at birth in Germany. *Hormone research.* 2006;66:195-203.

73. Diamanti-Kandarakis E, Bourguignon JP, Giudice LC, Hauser R, Prins GS, Soto AM, et al. Endocrine-disrupting chemicals: an Endocrine Society scientific statement. *Endocr Rev.* 2009;30:293-342.
74. Jorgensen N, Meyts ER, Main KM, Skakkebaek NE. Testicular dysgenesis syndrome comprises some but not all cases of hypospadias and impaired spermatogenesis. *Int J Androl.* 2010;33:298-303.
75. Main KM, Skakkebaek NE, Virtanen HE, Toppari J. Genital anomalies in boys and the environment. *Best Pract Res Clin Endocrinol Metab.* 2010;24:279-89.
76. Kalfa N, Philibert P, Baskin LS, Sultan C. Hypospadias: interactions between environment and genetics. *Mol Cell Endocrinol.* 2011;335:89-95.
77. Gaspari L, Paris F, Jandel C, Kalfa N, Orsini M, Daures JP, et al. Prenatal environmental risk factors for genital malformations in a population of 1442 French male newborns: a nested case-control study. *Hum Reprod.* 2011;26:3155-62.
78. Hsieh MH, Hollander A, Lamb DJ, Turek PJ. The genetic and phenotypic basis of infertility in men with pediatric urologic disorders. *Urology.* 2010;76:25-31.
79. Cools M, Looijenga LH, Wolffenbuttel KP, Drop SL. Disorders of sex development: update on the genetic background, terminology and risk for the development of germ cell tumors. *World journal of pediatrics : WJP.* 2009;5:93-102.
80. Tannour-Louet M, Han S, Corbett ST, Louet JF, Yatsenko S, Meyers L, et al. Identification of de novo copy number variants associated with human disorders of sexual development. *PLoS One.* 2010;5:e15392.
81. Cox MJ, Coplen DE, Austin PF. The incidence of disorders of sexual differentiation and chromosomal abnormalities of cryptorchidism and hypospadias stratified by meatal location. *J Urol.* 2008;180:2649-52; discussion 52.
82. Moreno-Garcia M, Miranda EB. Chromosomal anomalies in cryptorchidism and hypospadias. *J Urol.* 2002;168:2170-2; discussion 2.
83. Hughes IA, Deeb A. Androgen resistance. *Best Pract Res Clin Endocrinol Metab.* 2006;20:577-98.
84. Lim HN, Chen H, McBride S, Dunning AM, Nixon RM, Hughes IA, et al. Longer polyglutamine tracts in the androgen receptor are associated with

- moderate to severe undermasculinized genitalia in XY males. *Hum Mol Genet.* 2000;9:829-34.
85. Lim HN, Nixon RM, Chen H, Hughes IA, Hawkins JR. Evidence that longer androgen receptor polyglutamine repeats are a causal factor for genital abnormalities. *J Clin Endocrinol Metab.* 2001;86:3207-10.
  86. Ishii T, Sato S, Kosaki K, Sasaki G, Muroya K, Ogata T, et al. Micropenis and the AR Gene: mutation and CAG repeat-length analysis. *J Clin Endocrinol Metab.* 2001;86:5372-8.
  87. Virtanen HE, Bjerknes R, Cortes D, Jorgensen N, Rajpert-De Meyts E, Thorsson AV, et al. Cryptorchidism: classification, prevalence and long-term consequences. *Acta Paediatr.* 2007;96:611-6.
  88. Toppari J, Virtanen HE, Main KM, Skakkebaek NE. Cryptorchidism and hypospadias as a sign of testicular dysgenesis syndrome (TDS): environmental connection. *Birth Defects Res A Clin Mol Teratol.* 2010;88:910-9.
  89. Sasagawa I, Suzuki Y, Tateno T, Nakada T, Muroya K, Ogata T. CAG repeat length of the androgen receptor gene in Japanese males with cryptorchidism. *Mol Hum Reprod.* 2000;6:973-5.
  90. Fredell L, Kockum I, Hansson E, Holmner S, Lundquist L, Lackgren G, et al. Heredity of hypospadias and the significance of low birth weight. *J Urol.* 2002;167:1423-7.
  91. Aschim EL, Haugen TB, Tretli S, Daltveit AK, Grotmol T. Risk factors for hypospadias in Norwegian boys - association with testicular dysgenesis syndrome? *Int J Androl.* 2004;27:213-21.
  92. Muroya K, Sasagawa I, Suzuki Y, Nakada T, Ishii T, Ogata T. Hypospadias and the androgen receptor gene: mutation screening and CAG repeat length analysis. *Mol Hum Reprod.* 2001;7:409-13.
  93. Fluck CE, Meyer-Boni M, Pandey AV, Kempna P, Miller WL, Schoenle EJ, et al. Why boys will be boys: two pathways of fetal testicular androgen biosynthesis are needed for male sexual differentiation. *Am J Hum Genet.* 2011;89:201-18.
  94. Allali S, Muller JB, Brauner R, Lourenco D, Boudjenah R, Karageorgou V, et al. Mutation Analysis of NR5A1 Encoding Steroidogenic Factor 1 in 77 Patients with 46, XY Disorders of Sex Development (DSD) Including Hypospadias. *PLoS One.* 2011;6:e24117.

95. Swyer GI. Male pseudohermaphroditism: a hitherto undescribed form. *British medical journal*. 1955;2:709-12.
96. Behtash N, Karimi Zarchi M. Dysgerminoma in three patients with Swyer syndrome. *World journal of surgical oncology*. 2007;5:71.
97. Barbaro M, Cicognani A, Balsamo A, Lofgren A, Baldazzi L, Wedell A, et al. Gene dosage imbalances in patients with 46,XY gonadal DSD detected by an in-house-designed synthetic probe set for multiplex ligation-dependent probe amplification analysis. *Clinical genetics*. 2008;73:453-64.
98. Cox JJ, Willatt L, Homfray T, Woods CG. A SOX9 duplication and familial 46,XX developmental testicular disorder. *N Engl J Med*. 2011;364:91-3.
99. Sutton E, Hughes J, White S, Sekido R, Tan J, Arboleda V, et al. Identification of SOX3 as an XX male sex reversal gene in mice and humans. *J Clin Invest*. 2011;121:328-41.
100. Manecksha RP, Fitzpatrick JM. Epidemiology of testicular cancer. *BJU Int*. 2009;104:1329-33.
101. Rosen A, Jayram G, Drazer M, Eggener SE. Global trends in testicular cancer incidence and mortality. *Eur Urol*. 2011;60:374-9.
102. Chia VM, Quraishi SM, Devesa SS, Purdue MP, Cook MB, McGlynn KA. International trends in the incidence of testicular cancer, 1973-2002. *Cancer Epidemiol Biomarkers Prev*. 2010;19:1151-9.
103. Bray F, Richiardi L, Ekbom A, Pukkala E, Cuninkova M, Moller H. Trends in testicular cancer incidence and mortality in 22 European countries: continuing increases in incidence and declines in mortality. *Int J Cancer*. 2006;118:3099-111.
104. Salmela E, Lappalainen T, Liu J, Sistonen P, Andersen PM, Schreiber S, et al. Swedish population substructure revealed by genome-wide single nucleotide polymorphism data. *PLoS One*. 2011;6:e16747.
105. Ekbom A, Richiardi L, Akre O, Montgomery SM, Sparen P. Age at immigration and duration of stay in relation to risk for testicular cancer among Finnish immigrants in Sweden. *J Natl Cancer Inst*. 2003;95:1238-40.
106. Myrup C, Westergaard T, Schnack T, Oudin A, Ritz C, Wohlfahrt J, et al. Testicular cancer risk in first- and second-generation immigrants to Denmark. *J Natl Cancer Inst*. 2008;100:41-7.

107. Hemminki K, Li X. Cancer risks in Nordic immigrants and their offspring in Sweden. *Eur J Cancer*. 2002;38:2428-34.
108. Beiki O, Granath F, Allebeck P, Akre O, Moradi T. Subtype-specific risk of testicular tumors among immigrants and their descendants in Sweden, 1960 to 2007. *Cancer Epidemiol Biomarkers Prev*. 2010;19:1053-65.
109. Cook MB, Akre O, Forman D, Madigan MP, Richiardi L, McGlynn KA. A systematic review and meta-analysis of perinatal variables in relation to the risk of testicular cancer--experiences of the son. *International journal of epidemiology*. 2010;39:1605-18.
110. Petersen PM, Giwercman A, Hansen SW, Berthelsen JG, Daugaard G, Rorth M, et al. Impaired testicular function in patients with carcinoma-in-situ of the testis. *J Clin Oncol*. 1999;17:173-9.
111. Schnack TH, Poulsen G, Myrup C, Wohlfahrt J, Melbye M. Familial coaggregation of cryptorchidism, hypospadias, and testicular germ cell cancer: a nationwide cohort study. *J Natl Cancer Inst*. 2010;102:187-92.
112. Holl K, Lundin E, Surcel HM, Grankvist K, Koskela P, Dillner J, et al. Endogenous steroid hormone levels in early pregnancy and risk of testicular cancer in the offspring: a nested case-referent study. *Int J Cancer*. 2009;124:2923-8.
113. Bray F, Lortet-Tieulent J, Ferlay J, Forman D, Auvinen A. Prostate cancer incidence and mortality trends in 37 European countries: an overview. *Eur J Cancer*. 2010;46:3040-52.
114. Stroepe SA, Andriole GL. Prostate cancer screening: current status and future perspectives. *Nature reviews Urology*. 2010;7:487-93.
115. Merrill RM, Sloan A. Risk-adjusted incidence rates for prostate cancer in the United States. *Prostate*. 2011.
116. Bouchardy C, Fioretta G, Rapiti E, Verkooijen HM, Rapin CH, Schmidlin F, et al. Recent trends in prostate cancer mortality show a continuous decrease in several countries. *Int J Cancer*. 2008;123:421-9.
117. Kheirandish P, Chinegwundoh F. Ethnic differences in prostate cancer. *British journal of cancer*. 2011;105:481-5.
118. Roddam AW, Allen NE, Appleby P, Key TJ. Endogenous sex hormones and prostate cancer: a collaborative analysis of 18 prospective studies. *J Natl Cancer Inst*. 2008;100:170-83.

119. Calistro Alvarado L. Population differences in the testosterone levels of young men are associated with prostate cancer disparities in older men. *Am J Hum Biol.* 2010;22:449-55.
120. Zhang PL, Rosen S, Veeramachaneni R, Kao J, DeWolf WC, Bubley G. Association between prostate cancer and serum testosterone levels. *Prostate.* 2002;53:179-82.
121. Swerdlow AJ, Schoemaker MJ, Higgins CD, Wright AF, Jacobs PA. Cancer incidence and mortality in men with Klinefelter syndrome: a cohort study. *J Natl Cancer Inst.* 2005;97:1204-10.
122. Andriole GL, Bostwick DG, Brawley OW, Gomella LG, Marberger M, Montorsi F, et al. Effect of dutasteride on the risk of prostate cancer. *N Engl J Med.* 2010;362:1192-202.
123. Heracek J, Hampl R, Hill M, Starka L, Sachova J, Kuncova J, et al. Tissue and serum levels of principal androgens in benign prostatic hyperplasia and prostate cancer. *Steroids.* 2007;72:375-80.
124. Nishiyama T, Ikarashi T, Hashimoto Y, Suzuki K, Takahashi K. Association between the dihydrotestosterone level in the prostate and prostate cancer aggressiveness using the Gleason score. *J Urol.* 2006;176:1387-91.
125. Andersson AM, Jorgensen N, Frydelund-Larsen L, Rajpert-De Meyts E, Skakkebaek NE. Impaired Leydig cell function in infertile men: a study of 357 idiopathic infertile men and 318 proven fertile controls. *J Clin Endocrinol Metab.* 2004;89:3161-7.
126. Pavlovich CP, King P, Goldstein M, Schlegel PN. Evidence of a treatable endocrinopathy in infertile men. *J Urol.* 2001;165:837-41.
127. Giwercman A, Richiardi L, Kaijser M, Ekblom A, Akre O. Reduced risk of prostate cancer in men who are childless as compared to those who have fathered a child: a population based case-control study. *Int J Cancer.* 2005;115:994-7.
128. Jorgensen KT, Pedersen BV, Johansen C, Frisch M. Fatherhood status and prostate cancer risk. *Cancer.* 2008;112:919-23.
129. Chen HZ, Kirschenbaum A, Mandeli J, Hollander VP. The effect of dihydrotestosterone and culture conditions on proliferation of the human prostatic cancer cell line LNCaP. *Steroids.* 1992;57:269-75.
130. Sonnenschein C, Olea N, Pasanen ME, Soto AM. Negative controls of cell proliferation: human prostate cancer cells and androgens. *Cancer Res.* 1989;49:3474-81.



131. Bosland MC. Sex steroids and prostate carcinogenesis: integrated, multifactorial working hypothesis. *Ann N Y Acad Sci.* 2006;1089:168-76.
132. Pollard M, Suckow MA. Hormone-refractory prostate cancer in the Lobund-Wistar rat. *Exp Biol Med (Maywood).* 2005;230:520-6.
133. Pollard M, Luckert PH, Snyder D. Prevention and treatment of experimental prostate cancer in Lobund-Wistar rats. I. Effects of estradiol, dihydrotestosterone, and castration. *Prostate.* 1989;15:95-103.
134. Zhu C, Luong R, Zhuo M, Johnson DT, McKenney JK, Cunha GR, et al. Conditional expression of the androgen receptor induces oncogenic transformation of the mouse prostate. *J Biol Chem.* 2011;286:33478-88.
135. Taylor JA, Richter CA, Ruhlen RL, vom Saal FS. Estrogenic environmental chemicals and drugs: mechanisms for effects on the developing male urogenital system. *J Steroid Biochem Mol Biol.* 2011;127:83-95.
136. Ricke WA, Wang Y, Cunha GR. Steroid hormones and carcinogenesis of the prostate: the role of estrogens. *Differentiation.* 2007;75:871-82.
137. Chen M, Yeh CR, Chang HC, Vitkus S, Wen XQ, Bhowmick NA, et al. Loss of epithelial oestrogen receptor alpha inhibits oestrogen-stimulated prostate proliferation and squamous metaplasia via in vivo tissue selective knockout models. *The Journal of pathology.* 2011.
138. Simanainen U, McNamara K, Gao YR, McPherson S, Desai R, Jimenez M, et al. Anterior prostate epithelial AR inactivation modifies estrogen receptor expression and increases estrogen sensitivity. *American journal of physiology Endocrinology and metabolism.* 2011;301:E727-35.
139. Prins GS, Tang WY, Belmonte J, Ho SM. Perinatal exposure to oestradiol and bisphenol A alters the prostate epigenome and increases susceptibility to carcinogenesis. *Basic & clinical pharmacology & toxicology.* 2008;102:134-8.
140. Ekblom A, Wu J, Adami HO, Lu CM, Lagiou P, Trichopoulos D, et al. Duration of gestation and prostate cancer risk in offspring. *Cancer Epidemiol Biomarkers Prev.* 2000;9:221-3.
141. Carlsen E, Giwercman A, Keiding N, Skakkebaek NE. Evidence for decreasing quality of semen during past 50 years. *BMJ.* 1992;305:609-13.
142. Rajpert-De Meyts E. Developmental model for the pathogenesis of testicular carcinoma in situ: genetic and environmental aspects. *Hum Reprod Update.* 2006;12:303-23.

143. Akre O, Richiardi L. Does a testicular dysgenesis syndrome exist? *Hum Reprod.* 2009;24:2053-60.
144. Thorup J, McLachlan R, Cortes D, Nation TR, Balic A, Southwell BR, et al. What is new in cryptorchidism and hypospadias--a critical review on the testicular dysgenesis hypothesis. *Journal of pediatric surgery.* 2010;45:2074-86.
145. Fisher JS, Macpherson S, Marchetti N, Sharpe RM. Human 'testicular dysgenesis syndrome': a possible model using in-utero exposure of the rat to dibutyl phthalate. *Hum Reprod.* 2003;18:1383-94.
146. Andersson AM, Jensen TK, Juul A, Petersen JH, Jorgensen T, Skakkebaek NE. Secular decline in male testosterone and sex hormone binding globulin serum levels in Danish population surveys. *J Clin Endocrinol Metab.* 2007;92:4696-705.
147. Travison TG, Araujo AB, O'Donnell AB, Kupelian V, McKinlay JB. A population-level decline in serum testosterone levels in American men. *J Clin Endocrinol Metab.* 2007;92:196-202.
148. Skakkebaek NE, Giwercman A, de Kretser D. Pathogenesis and management of male infertility. *Lancet.* 1994;343:1473-9.
149. Krausz C. Male infertility: pathogenesis and clinical diagnosis. *Best Pract Res Clin Endocrinol Metab.* 2011;25:271-85.
150. Mifsud A, Sim CK, Boettger-Tong H, Moreira S, Lamb DJ, Lipshultz LI, et al. Trinucleotide (CAG) repeat polymorphisms in the androgen receptor gene: molecular markers of risk for male infertility. *Fertil Steril.* 2001;75:275-81.
151. Tut TG, Ghadessy FJ, Trifiro MA, Pinsky L, Yong EL. Long polyglutamine tracts in the androgen receptor are associated with reduced trans-activation, impaired sperm production, and male infertility. *J Clin Endocrinol Metab.* 1997;82:3777-82.
152. von Eckardstein S, Syska A, Gromoll J, Kamischke A, Simoni M, Nieschlag E. Inverse correlation between sperm concentration and number of androgen receptor CAG repeats in normal men. *J Clin Endocrinol Metab.* 2001;86:2585-90.
153. Giwercman YL, Xu C, Arver S, Pousette A, Reneland R. No association between the androgen receptor gene CAG repeat and impaired sperm production in Swedish men. *Clinical genetics.* 1998;54:435-6.

154. Yu J, Chen Z, Ni Y, Li Z. CFTR mutations in men with congenital bilateral absence of the vas deferens (CBAVD): a systemic review and meta-analysis. *Hum Reprod.* 2011.
155. Jorgensen N, Carlsen E, Nermoen I, Punab M, Suominen J, Andersen AG, et al. East-West gradient in semen quality in the Nordic-Baltic area: a study of men from the general population in Denmark, Norway, Estonia and Finland. *Hum Reprod.* 2002;17:2199-208.
156. Jorgensen N, Vierula M, Jacobsen R, Pukkala E, Perheentupa A, Virtanen HE, et al. Recent adverse trends in semen quality and testis cancer incidence among Finnish men. *Int J Androl.* 2011;34:e37-48.
157. Colborn T, vom Saal FS, Soto AM. Developmental effects of endocrine-disrupting chemicals in wildlife and humans. *Environmental health perspectives.* 1993;101:378-84.
158. Sharpe RM. Environmental/lifestyle effects on spermatogenesis. *Philos Trans R Soc Lond B Biol Sci.* 2010;365:1697-712.
159. Skinner MK, Manikkam M, Guerrero-Bosagna C. Epigenetic transgenerational actions of endocrine disruptors. *Reprod Toxicol.* 2011;31:337-43.
160. Schell LM, Burnitz KK, Lathrop PW. Pollution and human biology. *Annals of human biology.* 2010;37:347-66.
161. Ohtake F, Fujii-Kuriyama Y, Kawajiri K, Kato S. Cross-talk of dioxin and estrogen receptor signals through the ubiquitin system. *J Steroid Biochem Mol Biol.* 2011.
162. Abel J, Haarmann-Stemmann T. An introduction to the molecular basics of aryl hydrocarbon receptor biology. *Biol Chem.* 2010;391:1235-48.
163. McMillan BJ, Bradfield CA. The aryl hydrocarbon receptor sans xenobiotics: endogenous function in genetic model systems. *Molecular pharmacology.* 2007;72:487-98.
164. Mehta V, Vezina CM. Potential protective mechanisms of aryl hydrocarbon receptor (AHR) signaling in benign prostatic hyperplasia. *Differentiation.* 2011.
165. Ohtake F, Fujii-Kuriyama Y, Kato S. AhR acts as an E3 ubiquitin ligase to modulate steroid receptor functions. *Biochem Pharmacol.* 2009;77:474-84.
166. Ohtake F, Baba A, Takada I, Okada M, Iwasaki K, Miki H, et al. Dioxin receptor is a ligand-dependent E3 ubiquitin ligase. *Nature.* 2007;446:562-6.

167. Ohtake F, Baba A, Fujii-Kuriyama Y, Kato S. Intrinsic AhR function underlies cross-talk of dioxins with sex hormone signalings. *Biochem Biophys Res Commun.* 2008;370:541-6.
168. Ohtake F, Takeyama K, Matsumoto T, Kitagawa H, Yamamoto Y, Nohara K, et al. Modulation of oestrogen receptor signalling by association with the activated dioxin receptor. *Nature.* 2003;423:545-50.
169. Swedenborg E, Pongratz I, Gustafsson JA. Endocrine disruptors targeting ERbeta function. *Int J Androl.* 2010;33:288-97.
170. Brunnberg S, Andersson P, Poellinger L, Hanberg A. The constitutively active Ah receptor (CA-AhR) mouse as a model for dioxin exposure - Effects in reproductive organs. *Chemosphere.* 2011;85:1701-6.
171. Kollara A, Brown TJ. Four and a half LIM domain 2 alters the impact of aryl hydrocarbon receptor on androgen receptor transcriptional activity. *J Steroid Biochem Mol Biol.* 2010;118:51-8.
172. Morrow D, Qin C, Smith R, 3rd, Safe S. Aryl hydrocarbon receptor-mediated inhibition of LNCaP prostate cancer cell growth and hormone-induced transactivation. *J Steroid Biochem Mol Biol.* 2004;88:27-36.
173. Fritz WA, Lin TM, Cardiff RD, Peterson RE. The aryl hydrocarbon receptor inhibits prostate carcinogenesis in TRAMP mice. *Carcinogenesis.* 2007;28:497-505.
174. Fritz WA, Lin TM, Safe S, Moore RW, Peterson RE. The selective aryl hydrocarbon receptor modulator 6-methyl-1,3,8-trichlorodibenzofuran inhibits prostate tumor metastasis in TRAMP mice. *Biochem Pharmacol.* 2009;77:1151-60.
175. Dietrich C, Kaina B. The aryl hydrocarbon receptor (AhR) in the regulation of cell-cell contact and tumor growth. *Carcinogenesis.* 2010;31:1319-28.
176. Shah SR, Freedland SJ, Aronson WJ, Kane CJ, Presti JC, Jr., Amling CL, et al. Exposure to Agent Orange is a significant predictor of prostate-specific antigen (PSA)-based recurrence and a rapid PSA doubling time after radical prostatectomy. *BJU Int.* 2009;103:1168-72.
177. Prins GS. Endocrine disruptors and prostate cancer risk. *Endocr Relat Cancer.* 2008;15:649-56.
178. Boffetta P, Mundt KA, Adami HO, Cole P, Mandel JS. TCDD and cancer: A critical review of epidemiologic studies. *Crit Rev Toxicol.* 2011;41:622-36.

179. Mocarelli P, Gerthoux PM, Needham LL, Patterson DG, Jr., Limonta G, Falbo R, et al. Perinatal exposure to low doses of dioxin can permanently impair human semen quality. *Environmental health perspectives*. 2011;119:713-8.
180. Adamsson A, Simanainen U, Viluksela M, Paranko J, Toppari J. The effects of 2,3,7,8-tetrachlorodibenzo-p-dioxin on foetal male rat steroidogenesis. *Int J Androl*. 2009;32:575-85.
181. Guo YL, Hsu PC, Hsu CC, Lambert GH. Semen quality after prenatal exposure to polychlorinated biphenyls and dibenzofurans. *Lancet*. 2000;356:1240-1.
182. Giordano F, Abballe A, De Felip E, di Domenico A, Ferro F, Grammatico P, et al. Maternal exposures to endocrine disrupting chemicals and hypospadias in offspring. *Birth Defects Res A Clin Mol Teratol*. 2010;88:241-50.
183. Fernandez MF, Olmos B, Granada A, Lopez-Espinosa MJ, Molina-Molina JM, Fernandez JM, et al. Human exposure to endocrine-disrupting chemicals and prenatal risk factors for cryptorchidism and hypospadias: a nested case-control study. *Environmental health perspectives*. 2007;115 Suppl 1:8-14.
184. Scott HM, Hutchison GR, Mahood IK, Hallmark N, Welsh M, De Gendt K, et al. Role of androgens in fetal testis development and dysgenesis. *Endocrinology*. 2007;148:2027-36.
185. Welsh M, Saunders PT, Fiske M, Scott HM, Hutchison GR, Smith LB, et al. Identification in rats of a programming window for reproductive tract masculinization, disruption of which leads to hypospadias and cryptorchidism. *J Clin Invest*. 2008;118:1479-90.
186. Hayes TB, Anderson LL, Beasley VR, de Solla SR, Iguchi T, Ingraham H, et al. Demasculinization and feminization of male gonads by atrazine: Consistent effects across vertebrate classes. *J Steroid Biochem Mol Biol*. 2011;127:64-73.
187. Foster PM. Disruption of reproductive development in male rat offspring following in utero exposure to phthalate esters. *Int J Androl*. 2006;29:140-7; discussion 81-5.
188. Rocheleau CM, Romitti PA, Dennis LK. Pesticides and hypospadias: a meta-analysis. *Journal of pediatric urology*. 2009;5:17-24.
189. Nassar N, Abeywardana P, Barker A, Bower C. Parental occupational exposure to potential endocrine disrupting chemicals and risk of

- hypospadias in infants. *Occupational and environmental medicine*. 2010;67:585-9.
190. Prins GS, Birch L, Tang WY, Ho SM. Developmental estrogen exposures predispose to prostate carcinogenesis with aging. *Reprod Toxicol*. 2007;23:374-82.
  191. Richthoff J, Rylander L, Hagmar L, Malm J, Giwercman A. Higher sperm counts in Southern Sweden compared with Denmark. *Hum Reprod*. 2002;17:2468-73.
  192. Vermeulen A, Verdonck L, Kaufman JM. A critical evaluation of simple methods for the estimation of free testosterone in serum. *J Clin Endocrinol Metab*. 1999;84:3666-72.
  193. Manjer J, Carlsson S, Elmstahl S, Gullberg B, Janzon L, Lindstrom M, et al. The Malmo Diet and Cancer Study: representativity, cancer incidence and mortality in participants and non-participants. *Eur J Cancer Prev*. 2001;10:489-99.
  194. Manjer J, Elmstahl S, Janzon L, Berglund G. Invitation to a population-based cohort study: differences between subjects recruited using various strategies. *Scand J Public Health*. 2002;30:103-12.
  195. Lundberg Giwercman Y, Nikoshkov A, Lindsten K, Bystrom B, Pousette A, Chibalin AV, et al. Functional characterisation of mutations in the ligand-binding domain of the androgen receptor gene in patients with androgen insensitivity syndrome. *Human genetics*. 1998;103:529-31.
  196. Toulis KA, Iliadou PK, Venetis CA, Tsametiis C, Tarlatzis BC, Papadimas I, et al. Inhibin B and anti-Mullerian hormone as markers of persistent spermatogenesis in men with non-obstructive azoospermia: a meta-analysis of diagnostic accuracy studies. *Hum Reprod Update*. 2010;16:713-24.
  197. Mangerich A, Burkle A. How to kill tumor cells with inhibitors of poly(ADP-ribosyl)ation. *Int J Cancer*. 2011;128:251-65.
  198. Lockett KL, Hall MC, Xu J, Zheng SL, Berwick M, Chuang SC, et al. The ADPRT V762A genetic variant contributes to prostate cancer susceptibility and deficient enzyme function. *Cancer Res*. 2004;64:6344-8.
  199. Morcillo-Suarez C, Alegre J, Sangros R, Gazave E, de Cid R, Milne R, et al. SNP analysis to results (SNPator): a web-based environment oriented to statistical genomics analyses upon SNP data. *Bioinformatics*. 2008;24:1643-4.

200. Benjamini Y, Hochberg Y. CONTROLLING THE FALSE DISCOVERY RATE - A PRACTICAL AND POWERFUL APPROACH TO MULTIPLE TESTING. *J R Stat Soc Ser B-Methodol.* 1995;57:289-300.
201. Storey JD, Tibshirani R. Statistical significance for genomewide studies. *Proc Natl Acad Sci U S A.* 2003;100:9440-5.
202. Radpour R, Rezaee M, Tavasoly A, Solati S, Saleki A. Association of long polyglycine tracts (GGN repeats) in exon 1 of the androgen receptor gene with cryptorchidism and penile hypospadias in Iranian patients. *Journal of andrology.* 2007;28:164-9.
203. Lundin KB, Giwercman A, Dizeyi N, Giwercman YL. Functional in vitro characterisation of the androgen receptor GGN polymorphism. *Mol Cell Endocrinol.* 2007;264:184-7.
204. Ding D, Xu L, Menon M, Reddy GP, Barrack ER. Effect of GGC (glycine) repeat length polymorphism in the human androgen receptor on androgen action. *Prostate.* 2005;62:133-9.
205. Davis-Dao CA, Tuazon ED, Sokol RZ, Cortessis VK. Male infertility and variation in CAG repeat length in the androgen receptor gene: a meta-analysis. *J Clin Endocrinol Metab.* 2007;92:4319-26.
206. Nenonen HA, Giwercman A, Hallengren E, Giwercman YL. Non-linear association between androgen receptor CAG repeat length and risk of male subfertility--a meta-analysis. *Int J Androl.* 2011;34:327-32.
207. Nenonen H, Bjork C, Skjaerpe PA, Giwercman A, Rylander L, Svartberg J, et al. CAG repeat number is not inversely associated with androgen receptor activity in vitro. *Mol Hum Reprod.* 2010;16:153-7.
208. Rajender S, Rajani V, Gupta NJ, Chakravarty B, Singh L, Thangaraj K. No association of androgen receptor GGN repeat length polymorphism with infertility in Indian men. *Journal of andrology.* 2006;27:785-9.
209. Akinloye O, Gromoll J, Nieschlag E, Simoni M. Androgen receptor gene CAG and GGN polymorphisms in infertile Nigerian men. *J Endocrinol Invest.* 2009;32:797-804.
210. Castro-Nallar E, Bacallao K, Parada-Bustamante A, Lardone MC, Lopez PV, Madariaga M, et al. Androgen receptor gene CAG and GGN repeat polymorphisms in Chilean men with primary severe spermatogenic failure. *Journal of andrology.* 2010;31:552-9.

211. Ferlin A, Garolla A, Bettella A, Bartoloni L, Vinanzi C, Roverato A, et al. Androgen receptor gene CAG and GGC repeat lengths in cryptorchidism. *Eur J Endocrinol*. 2005;152:419-25.
212. Yamamoto M, Hibi H, Katsuno S, Miyake K. Serum estradiol levels in normal men and men with idiopathic infertility. *Int J Urol*. 1995;2:44-6.
213. Hargreave TB, Elton RA, Sweeting VM, Basralian K. Estradiol and male fertility. *Fertil Steril*. 1988;49:871-5.
214. Tajar A, Forti G, O'Neill TW, Lee DM, Silman AJ, Finn JD, et al. Characteristics of secondary, primary, and compensated hypogonadism in aging men: evidence from the European Male Ageing Study. *J Clin Endocrinol Metab*. 2010;95:1810-8.
215. Risbridger GP, Almahbobi GA, Taylor RA. Early prostate development and its association with late-life prostate disease. *Cell and tissue research*. 2005;322:173-81.
216. Walsh TJ, Schembri M, Turek PJ, Chan JM, Carroll PR, Smith JF, et al. Increased risk of high-grade prostate cancer among infertile men. *Cancer*. 2010;116:2140-7.
217. Wilt TJ, Macdonald R, Hagerly K, Schellhammer P, Tacklind J, Somerfield MR, et al. 5-alpha-Reductase inhibitors for prostate cancer chemoprevention: an updated Cochrane systematic review. *BJU Int*. 2010;106:1444-51.





## **ORIGINAL PUBLICATIONS**

