



# LUND UNIVERSITY

## Molecular mechanisms underlying morphological effects of protein kinase C under normal conditions and cellular stress.

Sunesson, Lovisa

2008

[Link to publication](#)

*Citation for published version (APA):*

Sunesson, L. (2008). *Molecular mechanisms underlying morphological effects of protein kinase C under normal conditions and cellular stress*. [Doctoral Thesis (compilation), Department of Translational Medicine]. Lund University: Faculty of Medicine.

*Total number of authors:*

1

### General rights

Unless other specific re-use rights are stated the following general rights apply:

Copyright and moral rights for the publications made accessible in the public portal are retained by the authors and/or other copyright owners and it is a condition of accessing publications that users recognise and abide by the legal requirements associated with these rights.

- Users may download and print one copy of any publication from the public portal for the purpose of private study or research.
- You may not further distribute the material or use it for any profit-making activity or commercial gain
- You may freely distribute the URL identifying the publication in the public portal

Read more about Creative commons licenses: <https://creativecommons.org/licenses/>

### Take down policy

If you believe that this document breaches copyright please contact us providing details, and we will remove access to the work immediately and investigate your claim.

LUND UNIVERSITY

PO Box 117  
221 00 Lund  
+46 46-222 00 00

From the department of Laboratory Medicine, Center for Molecular Pathology,  
Malmö University Hospital, Lund University, Sweden

# **Molecular Mechanisms Underlying Morphological Effects of Protein Kinase C Under Normal Conditions and Cellular Stress**

**Lovisa Sunesson**



**LUND UNIVERSITY**  
Faculty of Medicine

## **Academic Dissertation**

By due permission of the Faculty of Medicine, Lund University, Sweden, to be defended at the main lecture hall, Pathology building, University Hospital MAS, on Friday 5<sup>th</sup> of December, 2008, at 9.00 for the degree of Doctor of Philosophy, Faculty of Medicine.

## **Faculty Opponent**

Johanna Ivaska  
University of Turku and VTT Biotechnology Centre,  
Turku, Finland

Organization LUND UNIVERSITY  Department of Laboratory Medicine Center for Molecular Pathology Malmö University Hospital MAS	Document name DOCTORAL DISSERTATION	
	Date of issue 5th of December 2008	
	Sponsoring organization	
Author(s) Lovisa Sunesson		
Title and subtitle Mol. Mechanisms Underlying Morph. Effects of PKC under Normal Conditions and Cellular Stress		
Abstract <p>The protein kinase C (PKC) family of serine/threonine kinases consists of 10-15 members. The PKC isoforms have central roles in many essential cellular processes, including proliferation, apoptosis, differentiation, cytoskeletal changes, and migration. The PKC family can be subgrouped into classical, novel and atypical isoforms depending on structure and sensitivity to the activators diacylglycerol, phorbol esters and Ca<sup>2+</sup>.</p> <p>We have previously reported of a neurite-inducing effect specific for PKC<math>\epsilon</math>, a novel PKC isoform. The effect has been shown to be mediated through the regulatory domain and independently of the catalytic activity of PKC<math>\epsilon</math>. Here we identify residues located in the base of the C1b domain important for the neurite-inducing effect of PKC<math>\epsilon</math>. We have in an approach to elucidate the mechanisms that mediate PKC<math>\epsilon</math>-induced neurite outgrowth performed a screening for proteins that interact with the most potent neurite-inducing PKC<math>\epsilon</math> construct. We have identified several novel PKC<math>\epsilon</math>-interacting proteins, including the intermediate filament peripherin and several mRNA-binding proteins. Peripherin and three RNA-binding proteins G3BP2, PABPC1, and IGF2BP3 were further investigated regarding their putative function in PKC<math>\epsilon</math>-mediated neurite outgrowth. However, no involvement could be detected for any of the investigated interacting proteins. Interactions between peripherin, G3BP2, PABPC1, or IGF2BP3 and PKC have been confirmed for endogenous proteins. The peripherin-PKC<math>\epsilon</math> interaction is mediated by the C1b domain. We have found that PKC<math>\epsilon</math> induces peripherin aggregation when the expression levels of peripherin are elevated and that an activation of PKC induces apoptosis of cells overexpressing peripherin. These novel findings can be of importance in understanding the mechanism behind the neurodegenerative disease amyotrophic lateral sclerosis (ALS), where aggregates containing peripherin are essentially always seen in afflicted tissues. The RNA-binding proteins were found to localize to specific RNA-granules, formed when cells are exposed to stress. PKC<math>\alpha</math>, rather than PKC<math>\epsilon</math>, was found to be the main PKC isoform found in these stress granules. We have furthermore discovered a role for PKC<math>\alpha</math> in regulating stress granule formation.</p>		
Key words: Protein Kinase C, neurite outgrowth, protein-protein-interactions, peripherin, amyotrophic lateral sclerosis, RNA-binding proteins, G3BP2, PABPC1, IGF2BP3, neuroblastoma		
Classification system and/or index termes (if any):		
Supplementary bibliographical information:	Language English	
ISSN and key title: 1652-8220	ISBN 978-91-86059-68-2	
Recipient's notes	Number of pages 109	Price
	Security classification	

Distribution by (name and address)

I, the undersigned, being the copyright owner of the abstract of the above-mentioned dissertation, hereby grant to all reference sources permission to publish and disseminate the abstract of the above-mentioned dissertation.

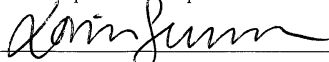
Signature 

Date 2008-10-31



# Table of Contents

<b>List of Papers .....</b>	<b>6</b>
<b>Abbreviations .....</b>	<b>7</b>
<b>Introduction .....</b>	<b>8</b>
<b>The Protein Kinase C .....</b>	<b>9</b>
<b>The PKC Structure .....</b>	<b>9</b>
- The Pseudosubstrate .....	9
- The C1 Domain .....	10
- The C2 Domain .....	10
- The C3 and C4 Domains.....	11
- The V5 Region .....	11
<b>The PKC Regulation.....</b>	<b>11</b>
- Binding of DAG/Phorbol Esters and Ca <sup>2+</sup> .....	11
- PKC Phosphorylation.....	12
- PKC Activators .....	12
- PKC Inhibitors .....	12
<b>The PKC Expression and Function .....</b>	<b>13</b>
- PKC Interactions .....	14
- PKC-Deficient Mouse Models .....	15
- PKCs in Cancer .....	16
<b>The Neuronal Cell: Morphology and Pathogenesis.....</b>	<b>17</b>
<b>Morphology and Development .....</b>	<b>17</b>
- The Role of the Cytoskeleton (The Intermediate Filaments, Peripherin) .....	17
<b>Regulators of Neuronal Processes .....</b>	<b>20</b>
- The RhoGTPases .....	20
- The PKCs .....	20
<b>Neuroblastoma (Genetics, Treatment) .....</b>	<b>21</b>
<b>Amyotrophic Lateral Sclerosis .....</b>	<b>22</b>
(Genetics, Pathogenesis, Apoptotic Mechanisms, Involvement of Peripherin)	
<b>mRNA Regulation .....</b>	<b>26</b>
<b>PABP .....</b>	<b>26</b>
<b>G3BP.....</b>	<b>26</b>
<b>IGF2BP .....</b>	<b>27</b>

<b>RNA Granules.....</b>	<b>27</b>
- Stress Granules (The SG Formation, SG Markers, The SG Regulation)	<b>27</b>
<b>The Present Investigation .....</b>	<b>30</b>
<b>Aim and Introduction .....</b>	<b>30</b>
<b>Results and Discussion .....</b>	<b>31</b>
<b>Conclusions .....</b>	<b>36</b>
<b>Popularized Summary in Swedish.....</b>	<b>37</b>
<b>Acknowledgements.....</b>	<b>38</b>
<b>References.....</b>	<b>40</b>
<b>Paper I</b>	
<b>Paper II (JBC Paper of the Week)</b>	
<b>Paper III</b>	
<b>Puzzles</b>	
<b>Notes</b>	

# List of Papers

This thesis is based on the following papers, which are referred as Papers I-III:

- I Mia Ling, Lovisa Sunesson, and Christer Larsson. Comparison of the PKC $\alpha$  and the PKC $\epsilon$  C1b Domains: Identification of Residues Critical for PKC $\epsilon$ -mediated Neurite Induction. *J. Mol. Biol.* 2007; 368: 951-65.
- II Lovisa Sunesson, Ulf Hellman, and Christer Larsson. Protein Kinase C  $\epsilon$  Binds Peripherin and Induces Its Aggregation, Which Is Accompanied by Apoptosis of Neuroblastoma Cells. *J. Biol. Chem.* 2008; 283:16653-64.
- III Lovisa Sunesson\*, Tamae Kobayashi\*, Ulf Hellman, and Christer Larsson. PKC $\alpha$  associates with the RNA-binding proteins PABPC1, IGF2BP3, and G3BP2 and regulates stress granule formation following cellular stress. *Manuscript*.  
\* *These authors contributed equally to this work*

Reprints were made with permission from the publishers:

© Elsevier 2007

© The American Society for Biochemistry and Molecular Biology 2008

# Abbreviations

ADAM12	a disintegrin and metalloprotease	mTOR	mammalian target of rapamycin
AIF	apoptosis-inducing factor	MTs	microtubules
Akt	"Ak" comes from a classification name for a mouse strain developing spontaneous thymic lymphomas and "t" stands for transforming.	MYCN	myelocytomatosis viral related oncogene, neuroblastoma derived
ALK	anaplastic lymphoma kinase	NF-H	neurofilament-heavy
ALS	amyotrophic lateral sclerosis	NF-κB	nuclear factor-kappa B
ATP	adenosine triphosphate	NFTPs	neurofilament triplet proteins
Bax	Bcl-2-associated X protein	NGF	nerve growth factor
Bcl-2	B-cell lymphoma 2	PABPC1	Poly(A)-binding protein cytoplasmic 1
Btk	Bruton tyrosine kinase	PBs	processing bodies
Ca <sup>2+</sup>	calcium	PDK-1	phosphoinositide-dependent protein kinase-1
Caspase	cysteine aspartyl-specific proteases	PH	pleckstrin homology domain
Cdc42	cell division cycle 42	PI3K	phosphatidylinositol 3-kinase
CNS	central nervous system	PI(4,5)P2	phosphatidylinositol 4,5-bisphosphate
DAG	diacylglycerol	PKC	protein kinase C
DGK	DAG kinase	PKD	protein kinase D
ECFP	enhanced cyano fluorescent protein	PLC	phospholipase C
EGFP	enhanced green fluorescent protein	PMA	phorbol 12-myristate 13-acetate
eIFs	eukaryotic translation-initiation factors	PNS	peripheral nervous system
ER	endoplasmic reticulum	PRK	protein kinase C-related kinase
F-actin	filamentous actin	PRPH	peripherin
FAK	focal adhesion kinase	RA	retinoic acid
GAPs	GTPase Activating Proteins	Rac1	Ras-related C3 botulinum toxin substrate 1
G3BP2	GTPase activating protein (SH3 domain) binding protein 2	RACK	receptor for activated C-kinase
GAP-43	growth associated protein 43	RhoA	Ras homolog gene family, member A
GDP	guanosine diphosphate	RICK	receptor for inactive C-kinase
GEFs	guanine exchange factors	RNA	ribonucleic acid
GFAP	glial fibrillary acidic protein	RNPs	ribonucleoproteins
Grb	growth factor receptor-bound protein	RRMs	RNA recognition motifs
GTP	guanosine triphosphate	SGs	stress granules
GTPase	guanosine triphosphatase	SH3	Src homology 3 domain
HER	human epidermal growth factor receptor	siRNA	silencing RNA
HSP	heat shock protein	SOD1	superoxide dismutase 1
Hu	human autoantigen	Src	sarcoma; kinase
IF	intermediate filaments	STICK	substrate that interact with C-kinase
IGF	insulin-like growth factor	TIA-1	T-cell internal antigen-1
IGF2BP3	IGF-II mRNA binding protein 3	TIAR	TIA-1-related protein
IL-6	interleukin-6	TNF	tumor necrosis factor
IMP	IGF-II mRNA binding protein	TPA	12- <i>O</i> -tetradecanoylphorbol-13-acetate
IP3	inositol triphosphate	TRAIL	TNF-related apoptosis inducing ligand
kDa	kiloDalton	TrkA	Tropomyosin-Related Kinase A
Lck	leukocyte-specific protein tyrosine kinase	TUNEL	terminal deoxynucleotidyl transferase biotin-dUTP nick end labeling
MDM2	murine double minute 2	WT	wild-type
MFs	actin microfilaments	ZBP	zipcode-binding protein
mRNA	messenger ribonucleic acid		



# Introduction

I was first introduced to protein kinase C (PKC) in January of 2003. Of course, I had probably read about the kinase during my previous studies, but never really thought anything special about it. In the beginning of 2003 I had reached the end point of my master's degree and it was time for doing my master's thesis. I began working with PKC, more exactly with PKCepsilon ( $\epsilon$ ), and initiated what would become an interesting journey in the world of PKC. I began investigating the mechanisms behind PKC $\epsilon$ -mediated neurite outgrowth but somewhere on the way my results led me in other directions.

The protein kinase C family of proteins was discovered in the late seventies (1) and named "C" after calcium. The family consists of serine/threonine protein kinases that phosphorylate or catalyze the transfer of phosphate from ATP to serine or threonine residues on their substrates. The family is divided into three groups, depending on their sensitivity to different co-activators such as the lipid second messenger diacylglycerol (DAG), phorbol esters (functional analogs of DAG) and  $\text{Ca}^{2+}$ , called classical, novel, and atypical PKCs. The sensitivity for  $\text{Ca}^{2+}$ , phospholipids and DAG was discovered by the same group that discovered PKC (2,3).

# The Protein Kinase C

The PKC molecule consists of one amino(N)-terminal regulatory half and one carboxy(C)-terminal catalytic or kinase half separated by a proteolytically labile hinge region (V3) (Figure 1). The catalytic domain is very similar to that of protein kinase A and protein kinase B (also known as Akt) (4-6). The PKC polypeptide consists of four conserved domains called C1 to C4, where each domain confers a special function to the protein, and five variable (V1-V5) domains positioned in-between the conserved domains (7-10). 12 PKC isoforms have so far been identified and several reviews describe their structure, regulation and function (11,12). The classical or the conventional PKC isozymes, first identified (10,13), include  $\alpha$ ,  $\beta$ I and  $\beta$ II (products of alternative splicing) (14), and  $\gamma$  isoforms. The classical PKCs are sensitive to DAG, phosphatidylserine, and  $\text{Ca}^{2+}$ . The novel PKC isozymes consist of  $\delta$ ,  $\epsilon$ ,  $\eta$ , and  $\theta$  isoforms. They are structurally related to the classical PKCs but do not bind  $\text{Ca}^{2+}$  and have higher affinity for diacylglycerol as compared to classical PKCs (15). The last group, the atypical PKCs, consists of  $\zeta$  and  $\iota/\lambda$  isoforms. These isozymes differ significantly from the other two groups in the sense that they only have one C1

domain insensitive to DAG/phorbol esters and no C2 domain (6,7). Additional kinases have been proposed to belong to the PKC family. The protein kinase C-related kinase (PRK) family of at least 3 proteins (PRK1-3) is one such example (12,16). Another example is the phospholipid-dependent kinase called PKD/PKC $\mu$ , which shows close homology to the regulatory domain of the novel PKCs (17,18).

## The PKC Structure

Elucidating the structure of the intact full-length PKC molecule has been difficult, whereas the structure of individual domains, such as the two membrane-binding domains C1 and C2, have been easier to determine (19-27). Recently the relationships between C1a, C1b, and C2 domains and the membrane or between individual domains and the catalytic domain were studied in an intact PKC $\delta$  crystal (28).

## The Pseudosubstrate

The pseudosubstrate is identical in all classical PKC isoforms and quite conserved among other isoforms and functions as an autoinhibitory domain by interacting with the C4 domain and maintaining PKC in an inactive state (7-9, 30). The pseudosubstrate was the first sequence shown to be involved in an intramolecular inhibitory interaction in PKC (29). The pseudosubstrate

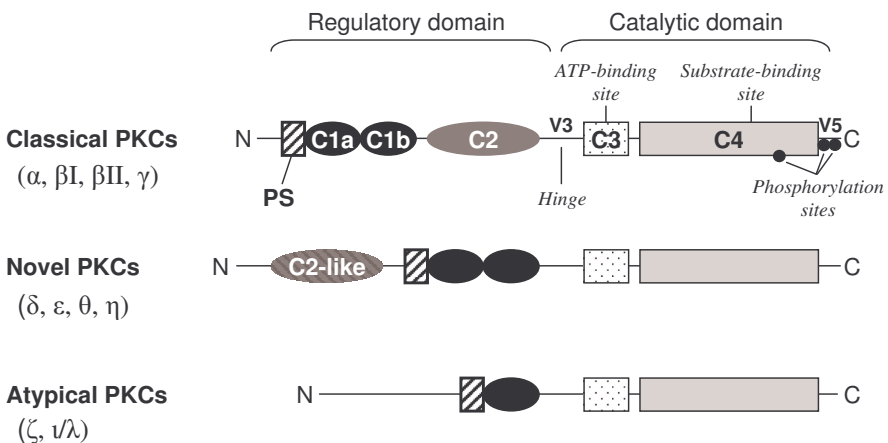

FIGURE 1. Schematic overview of the domain composition of the PKC isoforms. Abbreviations: C, carboxy; C1-4, conserved; N, amino; PS, pseudosubstrate; V, variable.

mimics the substrate consensus sequence except that it has an alanine instead of a phosphorylatable serine/threonine residue in its sequence. The pseudosubstrate consequently binds to the substrate binding site in the C4 domain without serving as a substrate (30). Upon binding of DAG or phorbol esters to the C1 domain, a conformational change of the PKC molecule leads to a relief of autoinhibition.

### The C1 Domain

The C1 domain consists of roughly 50 amino acids. It is often duplicated and the individual C1 domains have been termed C1a and C1b. The C1 domains bind diacylglycerol and phorbol esters, targeting the PKC molecule to the membrane, in all but the atypical PKCs (31) and depending on their ability to bind DAG/phorbol esters they are divided into either typical or atypical C1 domains. The C1 domains can also be divided into exposed and non-exposed C1 domains referring to the location of the C1 domain in the native full-length protein (32,33).

The C1 domain is a compact, globular structure that contains a cysteine-rich motif that coordinates two  $Zn^{2+}$  atoms and stabilizes the C1 domain structure (34). The first C1 domain structure to be determined was the one for PKC $\alpha$ C1b using NMR spectroscopy analysis (25). Later studies have revealed the structures of the PKC $\delta$ C1b and PKC $\gamma$ C1b domains and a model for the C1 domain has been established (Figure 2) (26,27). The binding pocket is located at the top of the C1 domain and consists of two unzipped  $\beta$  sheets that forms a ligand-binding hydrophilic groove surrounded by hydrophobic residues. When the C1 domain binds DAG/phorbol esters the hydrophobic residues in the C1 domain penetrate the membrane creating a contiguous hydrophobic surface without any conformational change (7,9,27,35-37). The penetration into the membrane and the following formation of a hydrophobic surface stabilizes the C1-membrane complex (38). The middle region of the C1 domain mainly contains positively charged residues that interact with the negatively charged phospholipids in the plasma membrane (32).

The equivalency of the C1a and C1b domains has

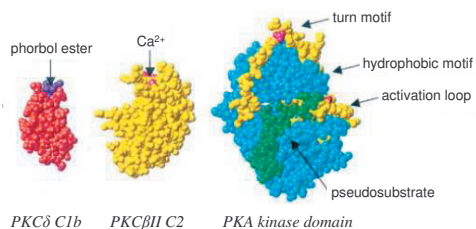

FIGURE 2. 3-dimensional structure of the C1b domain, C2 domain (with bound  $Ca^{2+}$ ), and kinase domain. Adapted from (6).

long been under investigation and it has been found that usually only one of the repeats bind DAG/phorbol esters and that the binding affinity for the C1 ligands differs between individual C1 domains and between C1 domains of different PKC isozymes (39-42). The atypical C1 domain differs in the structure compared to the typical C1 domains in that they lack the hydrophobic residues at the top of the C1 domain. In addition, the structure of the atypical C1 domain is not as flexible as the typical C1 domains making them unable to form a binding pocket (43,44). They are also more positively charged due to four extra arginine residues at the top of the C1 domain (45). PKCs are not the only proteins having C1 domains. Other proteins have been identified containing a C1 domain and the first one to be identified was *n*-chimaerin later renamed  $\alpha$ 1-chimaerin (46). Additional examples of C1-containing proteins binding DAG, are members of the PKD family and the DAG kinase (DGK) family, and the Munc13 family of scaffolding proteins (47,48). However, many of these proteins lack a kinase domain and are therefore called “non-kinase” phorbol ester receptors (49). The C1 domains are involved in intramolecular interactions as well as protein-protein interactions contributing to targeting the PKC molecule to different subcellular localizations (32,50).

### The C2 Domain

The C2 domain is about 130 amino acids long and consists of eight anti-parallel  $\beta$  strands. It contains a recognition site for acidic phospholipids, such as phosphatidylserine, and, in classical PKC isoforms, a  $Ca^{2+}$ -binding aspartate-lined

cleft (Figure 2) (9,35,37). These aspartates are not present in C2 domains that do not bind  $\text{Ca}^{2+}$  explaining why novel PKCs are calcium-insensitive and have low sequence homology to the C2 domains of classical PKC isoforms (51).  $\text{Ca}^{2+}$  functions as a link between the C2 domain and anionic phospholipids by inducing a conformational change of the C2 domain that enables the C2 domain to bind phospholipids and by increasing the affinity for negatively charged lipids (35,52). The classical PKC isoforms can be differentially regulated by changing the amount of calcium released upon receptor stimulation (53).

Many other proteins also contain C2 domains and when comparing C1 and C2 domains the C2 domains show much more functional diversities (12,35). The C2 domains are also involved in both intra- and intermolecular interactions important for PKC activation, translocation, substrate-binding and anchoring (54). Interactions between C1 and C2 domains of different PKC isoforms have been shown to stabilize and activate the PKC isoforms involved in the interaction (55).

### The C3 and C4 Domains

The C3 and C4 domain together constitute the catalytic domain and as much as 60% of this domain is shared between the different PKC isoforms (Figure 2) (56). The C3 domain contains the ATP-binding site and this site is the target for most PKC inhibitors (7,8). Replacing a conserved lysine residue in the ATP-binding site leads to a catalytically inactive kinase (57). The C4 domain contains the active site or the substrate-binding site and one of three PKC-regulatory phosphorylation sites, the autophosphorylation site (7,8).

### The V5 Region

The V5 region is very important in regulating the kinase activity of PKC, since it is here the two remaining phosphorylation sites regulating PKC activity are located (12). The V5 region contains a nuclear localization sequence (NLS) and is, like so many other PKC domains, also involved in intramolecular inhibitory interactions (58,59).

## The PKC Regulation

### Binding of DAG/Phorbol Esters and $\text{Ca}^{2+}$

Ligand-binding to G protein coupled receptors such as growth factor, neurotransmitter or hormone receptors, tyrosine kinase receptors, and nonreceptor tyrosine kinases leads to PKC activation via two mechanisms involving either phospholipase C (PLC) or phospholipase D (PLD) (Figure 3). PLC mediates hydrolysis of inositol phospholipids such as phosphatidylinositol 4,5-bisphosphate (PI(4,5)P<sub>2</sub>) yielding DAG and inositol 1,4,5-trisphosphate (IP<sub>3</sub>), which causes release of intracellular  $\text{Ca}^{2+}$ . PLD mediates hydrolysis of phosphatidylcholine, the principal phospholipid in the plasma membrane, yielding choline and phosphatidic acid, which in turn is converted into DAG by phosphomonoesterase (9,11). The DAG metabolism differs between the two different DAG products. DAG produced by PI(4,5)P<sub>2</sub> hydrolysis is rapidly converted into phosphatidic acid by DGK, whereas DAG produced from phosphatidylcholine is slowly degraded by a specific lipase (60).

Upon activation, classical and novel PKCs translocate from the cytosol to the membranes by binding to DAG/phorbol esters. DAG/phorbol esters serve as hydrophobic anchors to recruit PKC to the membranes as well as enhancing the affinity of PKC for phosphatidylserine by decreasing the  $\text{Ca}^{2+}$  concentration needed for phosphatidylserine-binding (31,61-63). For PKC to become fully activated the pseudosubstrate

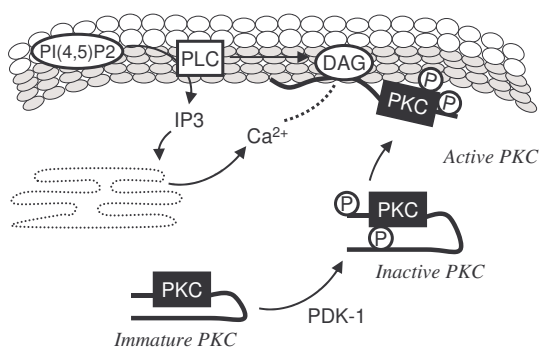

FIGURE 3. Illustration of the activation of classical and novel PKCs. DAG,  $\text{Ca}^{2+}$  and phosphorylation regulate PKC activity.

has to be removed from the C4 domain (9). This occurs when the C1 domain binds DAG/phorbol esters and the interaction also stabilizes an open conformation of the PKC molecule making the catalytic domain accessible for substrate binding and phosphorylation (4,62). In the absence of C1 ligands no selectivity for negatively charged head groups in acidic lipids can be observed (64). Binding of the C2 domain to phosphatidylserine does not in itself cause activation or pseudosubstrate release.

Other views about the precise pathway by which PKC becomes activated includes one that suggests that activation of classical PKCs is initiated by  $\text{Ca}^{2+}$ -binding, which increases the affinity for phosphatidylserine and followed by binding to DAG at the plasma membrane (65). A third model speaks for an independent relationship between the C1 and C2 domains, targeting the membrane independently of each other (66).

### **PKC Phosphorylation**

PKC is, in addition to ligand interactions, also regulated by phosphorylation (67). PKC has been shown to be autophosphorylated *in vitro* (68,69) and phosphorylated on at least three sites *in vivo* (Figure 2) (70,71). The first step includes transphosphorylation of a residue located in the kinase activation loop critical for enzyme activation (70-73). This phosphorylation site is thought to be hidden when the pseudosubstrate is bound to the active site and needs to be exposed to become phosphorylated (70). The second and third steps involve autophosphorylation of two C-terminal residues termed the turn motif and hydrophobic site. The hydrophobic site is present in many other kinases (70,71). However, phosphorylation of PKC only primes PKC during protein maturation and PKC still needs to interact with second messengers to become fully activated. Most PKC isoforms in resting cells are phosphorylated on all three phosphorylation sites, speaking for the phosphorylation events only being part of the PKC maturation and not in PKC regulation (9).

The activation loop is phosphorylated by the phosphoinositide-dependent kinase (PDK-1) at

the same time as it associates with the C-terminal of PKC (74-76). The PDK-1-association is thought to prevent PKC autophosphorylation and PDK-1 has to dissociate for autophosphorylation to occur. Autophosphorylation is also regulated by the fact that HSP70 also binds the C-terminal of PKC. This balance between HSP70 and PDK-1 binding not only protects PKC against dephosphorylation but also against degradation (77,78). PKCs become dephosphorylated upon chronic activation, which speaks for dephosphorylation being a way of modulating PKC function (4).

The phosphorylation motifs have been shown to be involved in an intramolecular clamp with the N-terminal part of the kinase as well as in an intramolecular interaction with the C2 domain (59,79).

### **PKC Activators**

Phorbol esters were shown in the early eighties to activate and translocate PKC to different cellular compartments (80) and have since been extensively used as PKC activators (7). 12-O-tetradecanoylphorbol-13-acetate (TPA) or phorbol 12-myristate 13-acetate (PMA) is the most frequently used phorbol ester and it has been one of the most valuable pharmacological tools in the study of carcinogenesis due to their effects as tumor promoters. TPA mediates PKC activation by binding competitively with DAG to the C1 domain causing an open conformation of PKC allowing for substrate-binding (27). Some caution should be made when using TPA for studying PKC effects, since other proteins than PKCs also are sensitive to this compound (12). Prolonged exposure to TPA and other phorbol esters leads to dephosphorylation and eventually downregulation of activated PKC by ubiquitination and proteasomal degradation (81,82).

### **PKC Inhibitors**

The lack of selectivity among PKC inhibitors due to high similarity between the kinase domains of the different PKC isoforms has resulted in difficulties when specific PKC isoforms need to be inhibited and has also prohibited the use of inhibitors as therapeutic agents (30). Most

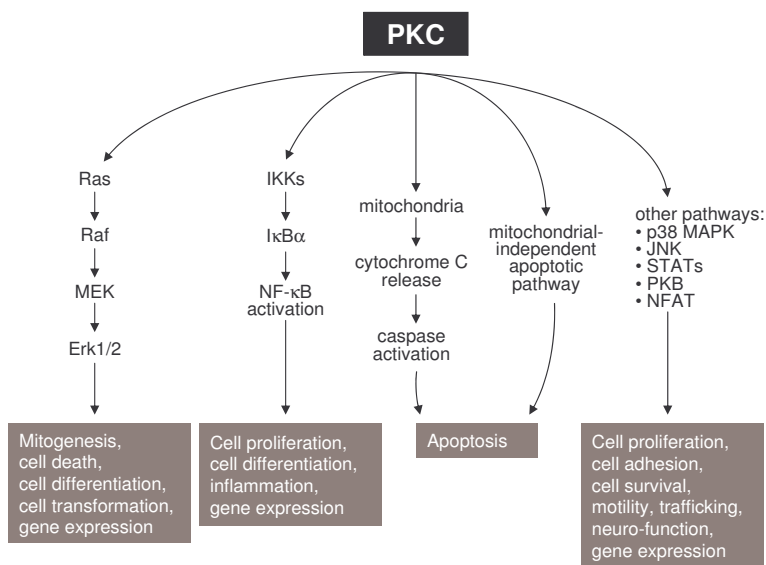

**FIGURE 4. Examples of signaling pathways PKCs are involved in.** The specific PKC effect depends on stimuli, cell type and isozyme-specific interaction partners. Abbreviations: JNK, c-JUN N-terminal kinase; ERK, extracellular signal-regulated kinase; IκB, inhibitor of κB; IKK, IκB kinase; MAPK, mitogen-activated protein kinase; MEK, mitogen-activated protein kinase kinase; NFAT, nuclear factor of activated T cells; NF-κB, nuclear factor κB; PKB, protein kinase B; STAT, signal transducer and activator of transcription. Modified from (48).

inhibitors target the ATP-binding site and this site is highly conserved among the PKC isoforms. Most PKC inhibitors belong to the indolocarbazol and the staurosporine-derived bisindolylmaleimide classes. Gö6976 belongs to the first class inhibiting classical PKCs, whereas GF109203X (also called bisindolylmaleimide I) belongs to the second class inhibiting all PKCs as well as other protein kinases (7). Calphostin C is another PKC inhibitor that instead of targeting the ATP-binding site targets the PKC C1 domain and impairs DAG/phorbol ester binding (83). Metabolites from the sphingolipid metabolism are inhibitory second messengers for PKC. Sphingosine interacts with the regulatory domain of PKC and inhibits its activity either by interfering with the PKC-binding to phosphatidylserine or DAG (84).

Since most PKC isoforms are activated and inhibited by similar mechanisms, there is a need to develop compounds that influence PKC function in an isoenzyme-specific way. One approach has

been to identify molecules that PKC-specifically either disturb anchoring or translocation of PKC (85). This has been accomplished by designing peptides that interfere with protein-protein interactions and peptides derived from the C2 domain of PKCβ, PKCδ, and PKCε have been shown to specifically inhibit translocation and function of the PKC isoforms they derive from (86,87).

Kinase-inactive or regulatory domains of PKCs are commonly used as dominant-negative inhibitors, but the high sequence similarity among the different PKC isozymes and the little knowledge about the intracellular targets of the constructs makes the use of these inhibitors questionable (48).

### The PKC Expression and Function

PKCα, βI, βII, δ, ε, and ζ are quite ubiquitously expressed and can be found in most tissues, whereas PKCγ, η, and θ are more restricted in their



expression (88-90). Of the PKC isoforms, PKC $\alpha$  is believed to be the most ubiquitously expressed PKC isoform (91). PKCs are involved in many normal cellular processes such as proliferation, differentiation, survival, and motility (Figure 4) (92-94). However, the PKC family has also been coupled to many other processes like cancer, pain sensation, diabetes, heart attack, stroke, heart failure, angiogenesis and the immune response (95).

PKC function depends on cell type and different subcellular localization of both PKC and its substrates (8,61,96,97). One PKC isoform can have one effect in one cell and another effect in another cell. In addition, the PKCs often have opposite effects to each other, complicating the analysis when trying to map a specific function to a specific isoform. Several approaches have been made to elucidate the roles of individual PKC domains in regulating PKC-specific functions. Construction of chimera proteins has helped to elucidate some unique PKC-specific domain functions. For example has the regulatory domain of PKC $\epsilon$  been shown to have both a growth-promoting and a neurite-inducing effect, whereas the catalytic domain confers tumorigenicity. The regulatory domain of PKC $\alpha$  and PKC $\delta$  inhibits cell growth (98-100).

### **PKC Interactions**

How can a protein that is a member of a group of proteins that share so many similarities, mediate unique cellular functions? The answer is by interacting with other proteins and these proteins regulate localization and function of PKC isozymes by several means (Figure 5). Some target PKCs to their proper cellular localizations in response to specific receptor-mediated activating signals. Some bring PKCs close to their substrates preventing inappropriate phosphorylations and others transport PKCs between different subcellular compartments. PKC-interacting proteins also help to integrate signals from different signaling pathways (96,114). Two categories of proteins function to bring PKCs close to their substrates (85). These are collectively called STICKs (substrates that interact with C-kinase) and RACKs (receptors for

activated C-kinase). STICKs are phospholipid-binding proteins that are located in the interface between membranes and cytoskeletal structures and found in several different subcellular compartments. Phosphorylation of STICKs by PKC leads to a functional change of the STICKs, affecting cell morphology, adhesion, and cell spreading. STICKs bind transiently in vivo to the regulatory domain of PKCs and they are, at least in vitro, not isozyme-specific (96). RACKs selectively bind to a specific sequence in the regulatory domain. They were the first proteins identified as PKC-anchors and they function to anchor translocated active PKC to specific membranes but are not substrates (115). The C2 domain of PKC has been shown to contain a 6-10 amino acid long sequence identical to the sequence found in the PKC-interacting RACK and has therefore been named pseudo-RACK (30,87). Binding to RACK enhances the catalytic activity of PKC by inhibiting the intramolecular interaction between the pseudo-RACK and the RACK-binding site stabilizing the active conformation of PKC. The first PKC-selective RACK to be cloned was the PKC $\beta$ II-selective RACK1 (116). RICKs (receptors for inactive C-kinase) are additional PKC-interacting proteins that are not PKC substrates (85).

A wide variety of PKC-interacting proteins with diverse functions have been identified illustrating the plethora of processes in which PKC is involved. Proteins, lipids, and second messengers have all been identified to bind different domains in PKC and some of the interacting proteins are PKC specific and PKC substrates, others are not. PKCs interact with many cytoskeletal proteins and many of these are also PKC substrates suggesting an important role for PKC in cytoskeletal regulation (117,118).

PKC $\alpha$  interacts with many proteins involved in actin cytoskeleton regulation. PKC $\alpha$  specifically interacts with the actin-bundling protein fascin via its C1b domain and functions as a negative regulator of cell motility (119). PKC $\alpha$  also interacts with  $\beta$ I integrin via its V3 hinge region having positive influence on actin assembly and  $\beta$ I integrin expression (120,121). PKC $\alpha$  is also involved in activating the stress fiber-mediating protein RhoA through binding to syndecan-4

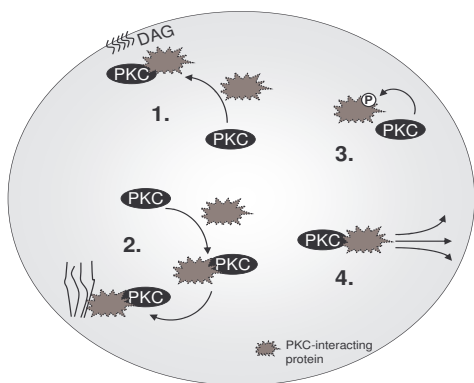

**FIGURE 5. PKC function is regulated by PKC-interacting proteins that enable isoform-specific functions.** The PKC-interacting proteins can 1) bring PKCs close to upstream activators; 2) transport different PKCs to different cellular compartments such as the cytoskeleton; 3) function as isoform-specific substrates or as scaffolds bringing PKCs close to their substrates; or, 4) form signaling complexes together with PKCs to enable isoform-specific signaling. Modified from (114).

during focal adhesion formation (122).

PKC $\beta$ II specifically interacts with pericentrin, a protein that anchors the microtubules to the centrosome, via its C1a domain. The interaction is important for bringing PKC $\beta$ II to the centrosome and inhibition of the interaction disrupt spindle formation and cell division (123).

PKC $\delta$  specifically binds the neuronal protein GAP-43 via its C2 domain and PKC $\delta$  has also been shown to interact with phosphotyrosine peptides via this domain (124,125).

PKC $\epsilon$  specifically interacts with the metalloprotease ADAM12 via two interacting sites located in the C1 and C2 domain and regulates the cell surface expression of ADAM12 (126). In addition, both PKC $\epsilon$  and PKC $\beta$ II contain F-actin-binding sites in their V3 region and V5 region, respectively (127-130). Binding to F-actin promotes PKC activation by keeping PKC in an open catalytically active conformation and influencing PKC localization (128). PKC $\epsilon$  also mediates an important protective role under cardiac ischemia by binding to the Src family member called Lck (131).

PKC $\zeta$  specifically binds to tubulin through its pseudosubstrate and the interaction is important for PKC $\zeta$  function (132).

Many PKC isozymes bind the conserved, ubiquitously expressed 14-3-3 family of scaffold proteins but so far the importance of these interactions in PKC signaling is not fully understood. There are indications of the 14-3-3 proteins both having PKC activity inhibiting as well as enhancing effects (133,134). PKC $\gamma$ ,  $\epsilon$ ,  $\theta$ , and  $\mu$  have all been found to bind 14-3-3 proteins via their C1 domains. Some members of the 14-3-3 family bind selectively to specific PKCs, others show no PKC selectivity (135-138).

Other proteins have also been found to bind PKCs unspecifically, such as the Bruton tyrosine kinase (Btk) that interacts with the C1 domain as well as the catalytic domain in several PKC isoforms (139,140).

### PKC-Deficient Mouse Models

PKC-knockout mice have been established in an attempt to understand individual functions of PKC. However, a problem with studying PKC-knockout mice is the question of functional redundancy between the different PKCs. In addition, most studies on PKC deficiency have been done in specific settings like the effects on the immune system and in colorectal cancer (141,142). Different effects on the immune system have been observed for mice lacking different PKC isoforms. For example, mice deficient for PKC $\beta$ I,  $\beta$ II, and  $\delta$  have aberrant regulation of B-cell activation and proliferation whereas PKC $\theta$ -deficient mice have impaired T-cell activation (143,144). PKC $\epsilon$  knockout mice show impaired macrophage function leading to lowered response to bacterial infections and increasing mortality as a consequence (145). No adverse phenotype has so far been discovered in PKC $\alpha$ -deficient mice (91). The roles of PKCs have been investigated in colorectal cancer by crossing PKC deficient mice with mice prone to develop colorectal cancer. In a more cancer susceptible environment, PKC $\alpha$  deficiency enhances cancer progression by upregulating EGFR signaling, whereas PKC $\zeta$  does not further potentiate the cancer phenotype. This is probably due to compensatory properties of PKC $\iota/\lambda$ . PKC $\iota/\lambda$  knockouts on the other hand are embryonic lethal (141).



## **PKCs in Cancer**

Dysregulation of PKC signaling may be one factor leading to uncontrolled cell proliferation and neoplastic transformation (7). Several PKC isoforms have been shown to mediate pathways important for tumorigenesis. Cell invasion has been shown to be mediated through PKC $\alpha$ ,  $\beta$ I and II, or  $\epsilon$  depending on tumor being investigated (101-103). PKC $\beta$ II has been shown to induce hyperproliferation in colonic epithelium (104). PKC $\alpha$  and PKC $\epsilon$  have in addition to tumor cell invasion also been implicated in regulating tumor growth and metastasis (105-109). However, targeting PKCs in cancer is quite complex, since the family consists of many members who could and probably have opposing effects and many PKCs have different functions in different cell types (107,110,111). For example, PKC $\epsilon$  has been shown to be both pro-survival as well as pro-apoptotic (112,113). It would be ideal if a specific isoform in a certain cancer type could be targeted to inhibit its pro-tumorigenic properties and limit cancer spread (91).

# The Neuronal Cell:

## Morphology and Pathogenesis

The nervous system consists of the central and peripheral nervous system (CNS and PNS). CNS includes the brain and spinal cord, whereas PNS refers to the somatic and autonomic nervous system. The somatic nervous system includes sensory and motor neurons. The autonomic nervous system, which control involuntary functions, can be further divided into a sympathetic and a parasympathetic part. During the development of the central and peripheral nervous systems many neurons undergo apoptosis and they also grow, remove and add neuronal processes and synapses all through life as part of a learning process (146). In contrast to many other cells, neurons are supposed to survive for the entire lifetime of the organism.

## Morphology and Development

One of the hallmarks of a mature, terminally differentiated neuron is the cell shape (Figure 6). It consists typically of a cell body with unusually long cytoplasmic processes where the longest is called the axon. In comparison, the immature neuron called neuroblast is small and round without processes and markers for neural differentiation. During the development of the nervous system the neurons have to migrate to their proper locations, differentiate, polarize, extend and their axons and dendrites have to be guided into right regions and form synapses with appropriate targets (147,148). All of these processes depend on the neuron's ability to respond to extra- and intracellular cues. The axon has to travel a long way, in humans as far as up to one meter, to synapse with their target cells and the dendrites have to undergo extensive growth and branching. The Notch signalling pathway has been shown to regulate dendritic growth and branching (149). At the tip of neuronal processes a specialized structure called the growth cone leads and directs the growth of the processes. The growth cone has an amoeboid movement due to actin assembly and disassembly of lamellipodia

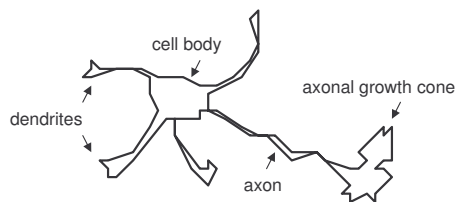

**FIGURE 6. Schematic picture of a neuronal cell during development.** The axonal growth cone is marked at the tip of the axon.

and filopodia that senses environmental cues (146,148). The lamellipodia and filopodia located in the right direction are stabilized by increasing cell adhesion and cytoskeletal stability (150). The axons and dendrites, important for receiving and transmitting electrical signals, are two distinct parts of the neuron and they differ in their protein and organelle composition. The axons are long and thin and of the same width, whereas the dendrites are short, thinner at their tips and heavily branched. Axons contain neurotransmitters in synaptic vesicles that they release at axon terminals upon stimulation, whereas dendrites contain receptors for released neurotransmitters (147).

## The Role of the Cytoskeleton

Three distinct intracellular filaments constitute the cytoskeleton including the actin microfilaments (MFs), microtubules (MTs), and intermediate filaments (IFs). Both the actin filaments and the microtubules are essential for the cell and both are arranged so that the subunits give the filaments directionality. MFs are important for maintaining cell shape, structure, motility and transducing signals in signaling pathways, whereas MTs are involved in mitosis, motility, and intracellular transport (159,160). Much research has focused on the importance of microfilaments and microtubules during neuronal development (161). Actin microfilaments are expressed at the edges of growth cones whereas microtubules mainly are localized to the central parts of growth cones (162). IFs constitute together with MTs the principal filamentous network in the axon and other neuronal processes.

## The Intermediate Filaments

IFs have received their name because the filament size (10-12 nm) is intermediate in size of the other two filaments (159,172). The family of IFs is one of the largest gene families in the human genome and it consists of at least 67 genes (173). The IF proteins are divided into six groups (type I-VI) or four groups (A-D) depending on if the IFs are grouped according to genetic sequence or protein polymerization (174,175). The IF expression patterns are cell- and tissue-specific, which means that each cell type has a specific IF protein composition. IF expression patterns also correlate to a tissue's differentiation state and the expression might therefore be under the regulation of different growth and differentiation factors (176). Unlike MFs and MTs, IF proteins are rod-shaped with a N-terminal globular head domain, a central conserved  $\alpha$ -helical domain of fixed length (either ~310 or ~352 residues long) and a C-terminal nonhelical tail domain (177). Both the head and tail domains differ in length and primary structure between the different IF proteins and conduce the diversity observed in this family (174,178). They self-assemble into apolar filaments without any necessity of ATP or GTP and the filaments generally connect the plasma membrane with the nucleus (159,179). Whereas the central rod domain helps with the self-assembly, the N-terminal domain and the C-terminal domain, projecting from the filament core, are involved in IF regulation and protein-protein-interactions (174). Both ends contain regulatory phosphorylation sites. IFs have been found to be rather dynamic, but are still considered to be the most stable filament of the three cytoskeletal filaments. Many functions have been ascribed to the IFs, but they mainly function as supportive scaffolds. IF proteins are also important for various signaling pathways such as apoptotic signalling, mediating cytoskeletal crosstalk, and relaying signals from plasma membrane to nucleus, but also for processes like protein synthesis, mechanical stress protection, and cell migration (159,180-183). IFs also play crucial roles for the positioning of organelles, contributing to their shape and function, as well as for targeting proteins to right subcellular locations (184). During the neuronal development, IF

proteins have different roles reflected by different localizations and expression patterns during different stages of development (163,164). Immature, undifferentiated neuronal cells only express vimentin (165). Developing neuroblasts express IF proteins like nestin,  $\alpha$ -internexin, and peripherin (166-168). Differentiation into mature neurons with axons triggers the expression of the neurofilament triplet proteins (NFTPs) (169). The NFTPs seem to be crucial for axon caliber in the mature axon (170). Mouse knockout experiments of individual IF genes do not have any severe effects on the development of the nervous system, axonal outgrowth proceeds as normal but some subsets of neurons are diminished (171).

### Peripherin

Peripherin is a 58 kDa intermediate filament protein that was first identified in neuroblastoma and pheochromocytoma cell lines and initially only thought to be expressed in the neurons of the PNS (168,225,226). Later it has become apparent that neurons of the CNS having axonal projections towards peripheral structures, such as motor and sensory neurons, also express peripherin (227). Even some neurons having their entire cellbody and processes within the CNS, like neurons in the cerebellum, express peripherin (228). Peripherin belongs to the type III intermediate filament proteins together with GFAP, desmin and vimentin (177). Peripherin is first assembled into insoluble, nonfilamentous particles and then transported to the right location in the cell where it assembles with pre-existing filaments. Peripherin can either constitutes an IF network alone or together with the NFTPs (229,230). Three peripherin isoforms have been described in mice, having molecular weights of 56, 58 and 61 kDa, respectively (231). The 58 kDa variant is primarily expressed *in vivo*, whereas the 61 kDa variant is very toxic and causes peripherin aggregate formation and cell death when overexpressed in cultured neuronal cells (232). However, the splicing event that results in the 61 kDa variant is unlikely to occur in human (233).

The biological function of peripherin is not yet fully understood. Peripherin mRNA and protein expressions increase after nerve injury, which might reflect a role in neuron regeneration (234-

238). Peripherin has its highest expression during early neuronal development. One potential role for peripherin during neuronal development might be in axonal guidance and outgrowth, since peripherin is expressed in neurons projecting their axons outside the CNS and studies performed in *Xenopus* embryos show peripherin being expressed in the distal region of the extending axon (164,230,239,241). In humans, all sensory neurons express peripherin and the majority of these possess thin unmyelinated axons and in the peripherin null mice fewer unmyelinated sensory axons are observed (245). Peripherin is also suggested to have a role in neuronal branching and branch stabilization, since a disruption of the peripherin network severely affects the axon sprouting capacity of affected neurons (240). Stimulation of rat pheochromocytoma PC12 cells, a cell line with high peripherin expression and widely used for studies on peripheral neurons, with NGF induces differentiation with neurite outgrowth and increased peripherin protein expression as a consequence (242). The importance of peripherin is further confirmed by the observation that downregulation of peripherin impairs processes like neurite initiation, extension, and maintenance in PC12 cells (243). However, there is contradictory work stating that knockdown of peripherin expression has no effect on NGF-induced neurite outgrowth in PC12 cells (244). In addition, peripherin knockout mice do not display any disruptions of processes like development, survival, and reproduction and seems to be indispensable for axogenesis. The pro-inflammatory cytokine tumor necrosis factor (TNF)  $\alpha$  as well as other inflammatory cytokines like interleukin-6 (IL-6) and leukemia inhibitory factor have been shown to upregulate peripherin expression (246-249). Exposure to ischemia induces peripherin expression in otherwise peripherin silent neurons (250).

Peripherin has been shown to be mainly phosphorylated on serine/threonine residues in its N-terminal half, like other class III IF proteins (251-253). However, there is evidence for tyrosine phosphorylation in the C-terminal of peripherin as well (251). TPA has been shown to increase peripherin phosphorylation and vimentin, a close homologue to peripherin, has been shown

to be phosphorylated by PKC (242,254,255). Phosphorylation of vimentin leads to disassembly of the IF, whereas dephosphorylation allows for spontaneous self-assembly (159). However, peripherin is also phosphorylated during NGF-stimulation and this phosphorylation is independent of PKC activation (242). Peripherin was recently found to be a novel Akt substrate in neurons and the phosphorylation site, a serine residue in the head domain, was identified (235). How phosphorylation exactly regulates peripherin function is still not known. A member of the 14-3-3 family has been shown to bind the IF protein GFAP in a phosphorylation-dependent manner, speaking for phosphorylation creating new binding-sites for proteins important for IF dynamics (256).

Peripherin has been found in the majority of IF inclusion bodies seen in motor neurons of amyotrophic lateral sclerosis (ALS) patients, but also in other neurodegenerative disorders like Parkinson's disease (238,257,258). Whereas peripherin deficiency does not lead to a severe phenotype, overexpression of peripherin in mice leads to a pathogenesis similar to that of ALS with the formation of peripherin inclusions and ultimately death of spinal motor neurons (259,260). The peripherin aggregates also seem to work in synergy with pro-inflammatory cytokines like the TNF- $\alpha$  to induce neuronal cell death (248). There might be an inverse relationship between the NFTPs and peripherin, since co-overexpression of the neurofilament protein NF-H prevents motor neuron loss seen in peripherin-overexpressing mice (261). In addition to neurodegenerative diseases, mutations of the IF genes have been found to be the cause of at least 30 different disorders like premature ageing, severe tissue fragility, and myopathies (262,263). Peripherin has also been found to be expressed in pancreatic islet  $\beta$  cells and suggested as a possible autoantigen in type I diabetes (264).

## Regulators of Neuronal Processes

### The RhoGTPases

The family of RhoGTPases has been shown to be involved in the neuronal developmental processes mentioned earlier (148,151). The RhoGTPases regulate dynamic changes of the actin cytoskeleton by transducing signals from extracellular stimuli (148). The RhoGTPases cycle between a GDP-bound inactive state and an active GTP-bound state. The guanine nucleotide exchange factors (GEFs) activate the RhoGTPases by facilitating the replacement of GDP to GTP, whereas the GTPase activating proteins (GAPs) inactivates the RhoGTPases by enhancing the intrinsic GTPase activity of the GTPases hydrolysing the GTP to GDP (152). The Rho family is further divided into three major groups where Rac1, Cdc42, and RhoA are the main members and the effects on the actin cytoskeleton differs between the members. In fibroblasts, Rac1 induces the formation of lamellipodia (ruffled membranes), Cdc42 induces filopodia (small protrusions), and RhoA induces stress fibers (filament bundles) and regulates focal adhesions (153-156). Rac1 and Cdc42 are positive regulators of neurite outgrowth and promote growth cone formation, whereas RhoA is a negative regulator that triggers growth cone collapse and neurite retraction in neuronal cells (157,158).

### The PKCs

Neurites are the general name for processes (axons and dendrites) extending from neuronal cell bodies. Initiation, extension, and maintenance of neurites involve coordinated processes of different cytoskeletal proteins and the PKC family was early implicated to be involved in neurite outgrowth regulation (118,185). Treating neuroblastoma cell lines like SK-N-BE(2)C with retinoic acid (RA) or stably TrkA-transfected SH-SY5Y with nerve growth factor (NGF) are two established differentiation model systems commonly used (186-188). The human neuroblastoma cell line SK-N-BE(2)C originates from the SK-N-BE(2) cell line, which was isolated from the bone marrow of a 22-month-old male boy 1972. They are neuroblast-like, have small neurite-like

processes, a nonfunctional, mutated p53, and a MYCN amplification (189). PKC $\alpha$ ,  $\beta$ II,  $\delta$ , and  $\epsilon$  are highly expressed in human neuroblastoma cells (100). PKC-activating phorbol esters have been shown to stimulate differentiation and induce neurite outgrowth in several neuroblastoma cell lines (190,191). TPA also potentiates NGF-stimulated neurite outgrowth (191). Ethanol is another agent shown to increase NGF- or basic fibroblast growth factor (bFGF)-stimulated neurite outgrowth in PC12 cells by increasing the levels of PKC $\delta$  and PKC $\epsilon$  (192,193). Induction of differentiation of LAN-5 neuroblastoma cells also leads to increased PKC $\epsilon$  levels compared to levels of PKC $\alpha$ ,  $\gamma$ ,  $\delta$ , and  $\zeta$  (194). However, there are also reports showing contradictory results where induced differentiation of either SK-N-BE(2)C cells with RA or SH-SY5Y/TrkA cells with NGF does not lead to any increase in PKC $\epsilon$  protein expression (130,195). In addition, PKC $\alpha$ , as well as PKC $\epsilon$ , has also been reported to be upregulated during neuronal differentiation as well as enriched in the growth cones (196). Both PKC $\delta$  as well as PKC $\epsilon$  have been shown to be neuritogenic and the regulatory domains from the novel PKC isoforms  $\delta$ ,  $\epsilon$ , and  $\eta$  all induce neurite outgrowth (130,195,197-201). Cellular processes have been induced in other cell types in addition to neuroblastoma cells, such as immortalized hippocampal neural precursor HiB5 cells and fibroblasts, and the ability to extend long processes is not something unique for neuronal cells but is rather a general process happening in many cell types (202-204).

### PKC $\epsilon$

However, full-length PKC $\epsilon$  is the only isoform that has been shown to induce neurite outgrowth and much research has focused on elucidating the mechanism whereby PKC $\epsilon$  mediates this effect. PKC $\epsilon$  is expressed in most tissues and cells, but with a higher expression in neuronal, hormonal, and immune cells and PKC $\epsilon$  is the main PKC isoform being expressed in the central nervous system (205-207). Deleting the actin-binding motif in the full-length PKC $\epsilon$  abrogates the neurite-inducing ability of PKC $\epsilon$  but targeting PKC to the membrane restores the neurite inducing capacity. The importance of the link between actin and PKC $\epsilon$  is further supported by

the observed increase in PKC $\epsilon$ -actin-association during neuronal development and the fact that the neurite-inducing capacity seem to be dependent on Cdc42 (130,195,197,208). The neurite-inducing capacity of PKC $\epsilon$  is dependent on extracellular stimuli, since removing serum from the medium diminishes its ability to induce neurites (130). In addition to being involved in neurite outgrowth-induction, PKC $\epsilon$  has been shown to be involved in many other cellular processes such as proliferation, differentiation, gene expression, muscle contraction, mechanical force adaptation, metabolism, transport, exocytosis, endocytosis and other inflammatory, immune, and circular functions (see(205) and references therein).

The neurite outgrowth-inducing capacity of PKC $\epsilon$  is independent of its catalytic activity and the regulatory domain of PKC $\epsilon$  is even a more potent neurite-inducer than full-length PKC $\epsilon$  (130). The region encompassing the pseudosubstrate, the two C1 domains, and parts of the V3 region (PSC1V3) in the regulatory domain is more neuritogenic than the regulatory domain. This construct can be used as a dominant negative inhibitor of neurite outgrowth induced by differentiation agents (201). Furthermore, we have previously shown that the C1b domain together with twelve N-terminal and twenty C-terminal residues have the capacity to induce neurite outgrowth when targeted to the membrane and that a conserved motif N-terminally of the C1b domain, present in the novel PKCs and absent in PKC $\alpha$ , is necessary for neurite induction. Mutation of three residues in this motif (Phe237, Val239, Met241) abolishes the neuritogenic effect of PKC $\epsilon$ PSC1V3. Amino acids located immediately N-terminally of the C1a domain has been shown to be important for membrane targeting and consequently neurite outgrowth induction (209). A way for PKC $\epsilon$  to induce neurite outgrowth might be through changing its localization and/or conformation and this might be mediated through interactions with other proteins at the membrane that either anchor PKC to the membrane or induce a conformational change.

## Neuroblastoma

During the neuronal development neural crest progenitor cells form a structure destined to be the spinal cord at the top of the neural tube. These cells later lay the ground for the entire PNS including the autonomic and peripheral ganglia and the adrenal gland (210). The adrenal glands produce many of the body's vital hormones and they consist of an outer cortex and an inner medulla that are developmentally, functionally, and structurally very different from each other. The cortex releases several steroid hormones whereas the medulla, being a part of the autonomic nervous system, releases catecholamines, mainly adrenaline, and peptidehormones. Pathology of the glands is most often due to neoplasms and the most common tumor of the adrenal medulla originates from the chromaffin cells and is called pheochromocytoma. Other tumors arising from primitive neuroblasts of the sympathetic PNS include neuroblastoma and ganglioneuroma (211).

Neuroblastoma is together with medulloblastoma the most common primary tumor in childhood and it is alone the most common extracranial malignancy found in children, representing roughly 7-10% of all childhood cancers (210,211). Approximately 200 children between the years of 2000 and 2004 were diagnosed for neuroblastoma in the nordic countries (Nordic Society of Pediatric Haematology and Oncology, 2007). Neuroblastoma is often diagnosed at around 18 months of age and can appear anywhere along the sympathetic PNS chain but roughly 65% of the tumors are found in the abdomen and in the adrenal medulla. The symptoms are linked to the location of the primary tumor and the most frequent symptom of neuroblastoma is abdominal pain due to abdominal distension (212,213). Unfortunately more than 50% of the patients have metastases at time of diagnosis and the most common locations of metastasis are regional lymph nodes, bone or bone marrow (211,212,214). Neuroblastomas detected in infants can regress spontaneously, even in the presence of metastases, or mature into benign ganglioneuroma and the outcome for these children is often better than for children older than 1 year of age (214). Patients with primary tumors



located in the adrenal gland often do worse than patients with tumors arising at other sites (214).

### Genetics

Most neuroblastomas are undifferentiated tumors and they are thought to develop due to disruption of the normal neural development; however, the exact mechanism behind this is not established. Searching for prenatal and/or postnatal environmental factors being responsible for neuroblastoma has so far been inconclusive. Most neuroblastomas occur spontaneously but there are cases of familial neuroblastoma and these are often diagnosed at an earlier age (215,216). Mutations in the ALK gene encoding a cell-surface kinase have just been discovered as the underlying cause to most familial neuroblastomas (217). About a third of the neuroblastoma tumors show amplification of the MYCN gene and this is the major marker for aggressive neuroblastoma correlating with poor prognosis (213,218). The transcription factor N-Myc is an important regulator of proliferation and differentiation of the developing peripheral neural crest and an inability of the early progenitor cells to exit from the proliferative phase could be a cause of tumor formation. High Myc pathway activation, not necessary due to MYCN gene amplification, has also been shown to correlate with poor prognosis (219). The TP53 gene, encoding the p53 protein, is often found mutated in cancers and an inactivation of p53 function contributes to malignant transformation. However, mutations in this gene are rarely found in primary neuroblastomas (220). High expression of the pro-survival nerve growth factor receptor TrkA is a favorable indicator of neuroblastoma (214). Aberrant Notch signaling has also been implicated in neuroblastoma (221). Many chromosomal aberrations are connected to neuroblastoma and unbalanced gain of distal 17q is the most common genetic abnormality found and deletion of 1p is found in 35% of primary tumors (222).

### Treatment

To be able to offer the best possible treatment to children with neuroblastoma, the tumors are classified depending on tumor stage, age of patient at diagnosis, and site of primary tumor (214). The most commonly used staging

system is called the International Neuroblastoma Staging System (INSS) and this is based on clinical, radiographic, and surgical evaluations of children with neuroblastoma (223). The use of a common staging system facilitates comparisons of treatments internationally. Treatment of childhood cancer is aggravated by the fact that childhood tumors differ from adulthood tumors since transformed normal cells are the source for proliferating tumor cells in adults whereas tumor cells in children originate from cells that already are rapidly dividing (210). Treatment of neuroblastoma begins with surgery and if needed continues with chemotherapy, and radiotherapy (224). During surgery, diagnosis is established, tissue samples are taken for further biological studies, the tumor is staged, and the entire tumor is excised without damaging adjacent tissue. Neuroblastomas often acquire drug resistance against drugs employed in therapy (189).

### Amyotrophic Lateral Sclerosis

ALS, or Lou-Gehrig's disease, is a rapid, progressive neurodegenerative disease where upper and lower motor neurons of the central nervous system degenerate (265). Examples of other neurological disorders where neuronal death underlies the symptoms are Alzheimer's, Parkinson's and Huntington's diseases, and stroke. Motor neurons affected in ALS include the motor neurons of the cerebral cortex (upper motor neurons), brain stem and spinal cord (lower motor neurons) (266,267). It is one of the most common neurodegenerative diseases with adult onset, having an incidence of one-two per 100 000 in the population (268). The loss of motor neurons leads to atrophy of skeletal muscles and progressive paralysis of all extremities and respiratory and sip musculature. Only 25 % of the ALS patients live beyond five years after diagnosis and most patients die due to respiratory failure (269,270). Men and women are almost equally affected with some overrepresentation among men and, unfortunately, the number of people who succumb to the disease is increasing (271). Usually the disorder occurs sporadically with unknown origin, but approximately 10 % of the cases are familial. However, because there are no clinical or pathological differences between

the types, the cases cannot be distinguished from each other. However, sporadic ALS has a later onset than familial ALS (266,269). A typical pathological hallmark of ALS is the presence of inclusion bodies, also called spheroids, in the perikaryon and axon of affected motor neurons of both sporadic and familial ALS. These inclusions typically contain aggregated proteins like peripherin and NTFs, the major IF protein in adult motor neurons (257,258,272,273). Abnormal IF accumulation is a pathological hallmark of many other neurodegenerative disorders besides ALS as dementia with Lewy bodies, Parkinson's disease, and neuropathies like diabetic neuropathy (171). Many of the detected inclusions are positive for ubiquitin, a common feature for protein accumulations in almost all neurodegenerative disorders (272,274,275). IF inclusions can also be seen in liver and muscle disorders (276). However, whether or not the IF accumulations contribute to the ALS pathogenesis is still not known (277). There are several possible mechanisms whereby proteins accumulate such as deregulation of IF protein synthesis, defective axonal transport, abnormal phosphorylation, proteolysis, and other protein modifications (171).

### Genetics

Little is known about what genetic defects contribute to ALS disease and so far no single gene has been shown to solely cause sporadic ALS (278). Several genes have been identified being mutated in ALS patients and these genes are often involved with intracellular trafficking and many of the mutations result in alternative splicing abnormalities (278). Due to the difficulty of investigating the ALS pathogenesis in humans, several mouse models have been created for investigating ALS origin and progression (245). One fifth of the familial ALS cases (or 5 % of the total ALS patients) have been found to be associated with dominantly inherited missense mutations in the gene coding for the free radical-scavenging enzyme copper/zinc superoxide dismutase-1 (SOD1) that exerts anti-oxidative and cytoprotective effects and is highest expressed within motor neurons (279-281). Mutations of the SOD1 gene are not restricted to familial ALS. They have also been found in patients with

sporadic ALS (282). Mutated SOD1 is thought to result in ALS either by causing intracellular oxidative damages or by becoming misfolded or aggregated leading to toxicity (283,284). Different SOD1 variants are more prone to self-aggregate than wild-type protein in transgenic mice (295). Many explanations to how SOD1 aggregation could promote cytotoxicity have been proposed, ranging from disrupting of axonal transport (285), binding to regulators of apoptosis (286), inhibiting the proteasome (287), interfering with mitochondrial function and  $Ca^{2+}$  homeostasis (288,289), and being connected with glutamate excitotoxicity (290). Over 100 mutations in nearly 50 % of the amino acids in SOD1 have been found in ALS patients (291). Transgenic mice models where the SOD1 gene has been mutated in different ways all show pathological hallmarks of familial ALS (292,293). SOD1 deficient mice develop normally and do not show any traces of neurodegeneration, but they do not cope with axonal injury to the same extent as normal mice (294). This speaks for the toxic effects of mutant SOD1 not only being due to its diminished enzymatic activity. Both intracellular SOD1- and peripherin-containing aggregates appear in motor neurons of transgenic mice before any symptoms are visible, suggesting that the protein aggregations could be important for the pathogenesis (296). Other genes have been found to be mutated in cases of familial ALS and several candidate genes have been investigated for their involvement of sporadic ALS (271). ALS and dementia have been seen to occur in the same families and might therefore share a common genetic background (297).

### Pathogenesis

So far, the complete picture of what causes the motor neuron death is not established. Much speaks for programmed cell death, apoptosis, being the process responsible for the observed cell death (298,299). The motor neuron degeneration observed in the human spinal cord can be divided into three consecutive morphological stages called chromatolysis, somatodendritic attrition and apoptosis (300). During chromatolysis the cell body swells and the so-called Nissl substance containing granular endoplasmic reticulum and ribosomes is dispersed; during the attritional



stage the cell body shrinks and the cytoplasm becomes homogenous and the nucleus condenses; and, in the final apoptotic stage the cells round up exhibiting a condensed nucleus and contracted cytoplasm and only display one fifth of its original size. Apoptosis is characterized morphologically by plasma membrane blebbing with preservation of its integrity, cytoplasmic condensation, compaction of cytoplasmic organelles, chromatin condensation, nuclear fragmentation, and finally the production of cell fragments surrounded by plasma membrane so called apoptotic bodies (270,301). Increased expression and activation of caspases-1 and -3 as well as apoptotic features support the apoptotic hypothesis (300,302,303). Many of the apoptotic changes are driven by caspases, a family of so far 14 inactive precursors that need to be proteolytically processed to generate active products. Caspases are activated by either the activation of the TNF family, the release of cytochrome C from the mitochondria to the cytosol, or by endoplasmic reticulum (ER) stress (304). Nevertheless, it is very difficult to find conclusive evidence for apoptosis in ALS patients, since the apoptotic process is a rapid process of a couple of hours to a day and the ALS progress is relatively slow. The probability of finding many motor neurons undergoing apoptosis at any given time in a post-mortem specimen is quite low. Many sections must be examined to find any apoptotic indices in post-mortem tissue from ALS patients (304,305). Evidence for apoptosis in ALS patients have been found by identifying higher levels of DNA fragmentation by nick-end labeling and TUNEL staining in neuronal tissue samples compared to normal tissue (306,307). Pro-apoptotic proteins, like Bax, have also been shown to have higher expression than anti-apoptotic proteins, like Bcl-2, in motor neurons of ALS patients and this expression imbalance between pro- and anti-apoptotic proteins could explain the observed apoptotic process (300,306,308). However, there are reports not supporting the presence of apoptosis (309). For example, there are studies without positive TUNEL staining of neuronal tissue from ALS patients (310).

### **Apoptotic Mechanisms**

There are several ways apoptosis can be induced

in neurons (305). For example it has been shown that a lack of neurotrophic factors triggers apoptotic pathways during neuronal development (311). Another way is by overactivating glutamate receptors, a receptor present on most neurons in the CNS, leading to increased calcium influx. There are several reports showing an aberrant glutamate metabolism in ALS patients and elevated glutamate levels have been found in the cerebrospinal fluid of ALS patients (312,313). Oxidative stress can also induce apoptosis by the production of free radicals that damage nucleic acid, induce protein and lipid modifications. Evidence for oxidative injury has been found in ALS cases (265). Environmental toxins, like alcohol and cigarette smoking, are other examples of candidate ALS risk factors being investigated (314,315). However, no solid link between smoking and ALS has yet been established. Unfortunately there is not much research being done on apoptosis-inhibiting drugs and their effects on human degenerative diseases, due to low specificity and undesirable adverse effects of current anti-apoptotic substances (270,306). It has also been proposed a role for p53 in motor neuron degeneration, since increased levels of p53 mRNA and protein has been associated with neuronal damage and an absent p53 protects neurons from toxic insults (299). Activation of the p53 pathway leads to a rapid increase of p53 mRNA and protein and this has been demonstrated in affected brain and spinal regions of ALS patients (316,317). However, p53 does not seem to be essential for SOD1-induced motor neuron death, since a crossbreed of SOD1-mutated mice and p53 deficient mice does not influence disease onset, progression or mortality induced by the SOD1 mutation (318).

### **Involvement of Peripherin**

Abberant peripherin expression could be one of the factors that contribute to ALS pathogenesis. Upregulation of peripherin mRNA has been found in a familial ALS case (232). A recent study has identified a novel peripherin splice variant, designated Per28, being upregulated both on mRNA- and protein level in ALS (233). The 28 kDa splice isoform is present in motor neuron inclusion bodies. The same group also recently unveiled the need of another novel peripherin

isoform, 45 kDa, for normal network formation (319). In addition, an abnormal neurotoxic splice variant of peripherin, 61 kDa, has been identified in spheroids in ALS cases and has been shown to induce peripherin and neurofilament aggregation when expressed in motor neurons (232). Frameshift and pointmutations in the *PRPH* gene coding for peripherin have been found in two ALS patients and these are both connected to peripherin aggregation (320,321). As mentioned earlier, peripherin expression can be increased by the inflammatory cytokine IL-6 and IL-6 levels have been found to be elevated in cerebrospinal fluid of an ALS patient (322).

Understanding the underlying mechanism of the neuronal cell death in ALS may provide new knowledge that can be used in the development of novel therapeutic techniques applied on neuronal protection in ALS patients. Furthermore, the development of effective neuroprotective strategies might be applicable on other neurodegenerative diseases like Alzheimer's and Parkinson's diseases.

## mRNA Regulation

Post-transcriptional regulation is one way of regulating gene expression and cells recognize changes in growth conditions by changing the rate of messenger-RNA (mRNA) translation. Specific RNA-binding proteins are thought to regulate cytoplasmic mRNA processes like translatability, stability, degradation, and localization. Three RNA-binding proteins have been of specific interest to our research.

### PABP

Pre-mRNAs undergo posttranscriptional modifications such as addition of a 5' 7-methyl-G cap and a 3' poly(A) tail. The poly(A) tail protects the mRNA from rapid degradation and it is involved in the processing and transportation of mRNA, as well as affecting translation efficiency. The poly(A) binding protein (PABP), discovered for more than 30 years ago, specifically binds to the 3' mRNA poly(A) tail and plays a role in translation initiation as well as in RNA stability protecting its bound RNAs from nuclease attacks (323-325). Each poly(A) tail binds several PABPs (326). PABPs are divided into two groups, nuclear and cytoplasmic, based on their intracellular location but lately more members have been found and added to the family (327). PABPC1, also called PABP1 or simply PABP, is mainly cytoplasmic and ubiquitously expressed. The poly(A) tail-PABPC1 complex stimulates translation initiation by interacting with the translation initiation factor eIF4G, a translation initiation factor with in a complex including other translation initiation factors, some bound to the 5' mRNA cap, ribosomal subunits, tRNAs, and accessory factors. Together PABPC1 and eIF4G form an 'end-to-end complex' or a 'closed loop' of the mRNA (324,328). PABPC1 also binds other eIF-interacting proteins further supporting the closed loop model (329). Translation initiation is the rate-limiting step during the translation process and at least 11 eIFs are needed for efficient translation. The PABPC1 sequence include four conserved, non-identical RNA-binding domains called RNA recognition motifs (RRMs) arranged

in tandem as well as a less conserved C-terminal domain that does not bind RNA (324). The role of PABPC1 in mRNA stability is less understood than its role in translation, but there are reports claiming that PABPC1 influences the decapping pathway as well as 3'-5' exosome-degradation (330).

### G3BP

The G3BP family of proteins is highly conserved between species and was originally identified in a screen for proteins binding to the SH3 domain of the RasGAP protein (331,332). RasGAP is a member of the Ras signaling pathway and the G3BPs have been shown to have a positive effect on cell proliferation and survival by affecting the cell cycle (331,333,334). G3BPs also affect cell growth by interacting with the cyclin-dependent kinase Cdk-7 and G3BP1 knocked out cells have reduced proliferation rate compared to control cells (335,336). The G3BP family consists of two highly homologous members, G3BP1 and G3BP2, encoded by genes located on separate chromosomes. G3BP2 additionally exist in two splice variants called G3BP2a and G3BP2b (337). The G3BP isoforms have a tissue-specific expression pattern and G3BP2 is the only isoform expressed in brain and muscle (337). The G3BPs are important during embryogenesis and a G3BP knockout is embryonic lethal, most likely due to neuronal cell death (336). The proteins all contain a N-terminal NTF2-like domain, a small SH3 domain binding sequence, an acid and proline rich central region and two different RNA binding domains termed RRM and RGG in the C-terminal (338,339). What functions can be attributed the G3BPs and whether they have overlapping or complementary functions are not completely understood. In addition to Ras signaling, the G3BPs have been shown to be involved in many other signaling pathways. They influence NF- $\kappa$ B signaling by sequestering the NF- $\kappa$ B-inhibiting factor in the cytoplasm (340), p53 signaling by directly binding to p53 and its key regulator MDM2 and stabilizing both proteins (341), as well as HER2 signaling where increased HER2 signaling induces G3BP1 mRNA and protein expression in breast cancer cells (342). They are also thought to regulate RNA metabolism,

but so far not many specific mRNA targets have been identified despite many efforts (336). They have been shown to bind specifically to c-Myc mRNA and to regulate its turnover by cleaving the 3' untranslated region using an internal phosphorylation-dependent endoribonuclease activity (343,344). G3BPs also interact with ubiquitin specific proteases, but whether the interaction has an activating or inhibiting effect has not yet been established (345). G3BPs have also been linked to cancer where G3BP1 has been found to be overexpressed in multiple tumour tissues and correlate to aggressiveness of esophageal squamous carcinoma and G3BP2 has been found to be overexpressed in breast cancer tissue (333,338,346). G3BP1 has also been shown to induce specific RNA granules called stress granules (SGs) when overexpressed and the role of the G3BPs in the SGs might be to determine the fate of mRNAs during stress (347,348).

### **IGF2BP**

The insulin-like growth factor-II mRNA-binding protein (IGF2BP or IMP) family consists of three highly homologous proteins that exhibit high affinity and multiple attachment sites for the mRNA encoding the growth factor IGF-II. IGF2BP1 was initially found to be a translation repressor of IGF-II mRNA during embryogenesis and IGF2BPs follow the expression pattern of IGF-II during development (349,350). During development IGF2BPs localize to cytoplasmic RNA-containing granules and these might constitute a specific entity of granules (351,352). IGF2BP1 expression is absent in most adult tissues except for testis and blood stem cells (353,354). IGF2BP3 was first identified as the protein KOC (KH domain containing protein overexpressed in cancer), which was overexpressed in pancreatic cancer cell lines and tissue (355). The IGF2BP family is suggested to have an important posttranscriptionally role by determining mRNA localization and stability as well as influencing translation initiation. IGF2BPs recognize and bind to specific mRNAs such as the c-Myc mRNA stabilizing and enhancing the mRNA half-life (356). Several reports show increased expression of IGF2BP1 in certain tumors (356-358). Downregulation of IGF2BP1 in breast cancer

cells leads to downregulation of c-myc mRNA and protein, upregulation of IGF-II mRNA, and a decrease in cell proliferation (353). The IGF2BP chicken ortholog zipcode-binding protein (ZBP) has been shown to localize to SGs during stress (359).

### **RNA Granules**

The formation of RNA containing granules so-called ribonucleoprotein (RNP) granules is a common cellular process and mRNP granules can be seen in germ cells as well as in neurons (360,361). The granules are especially evident in neuronal cells where RNA has to be transported over long distances to certain cytoplasmic compartments for local translation (362,363). Other examples of RNA-containing granules are the so-called processing bodies (PBs) (360). These regulate RNA metabolism by influencing RNA degradation, which occurs by two mechanisms; either by 3'-5' exonucleases or by irreversible decapping. PBs are dynamic, cytoplasmic RNA granules containing translationally silenced mRNAs, decapping enzymes, and scaffold proteins (361,364-366). The size and number of PBs depend on the number of mRNAs undergoing decapping. mRNAs are constantly being screened for containment of nonsense codons through the nonsense-mediated mRNA decay (NMD) pathway and those mRNAs positive for these codons are targeted to the PBs (367). Even though PBs are mainly involved in mRNA degradation, there is emerging evidence that points to the fact that mRNAs present in the PBs can return to the cytoplasm and resume active translation (368). How many different RNA granules there are is not known and the identification of the compositions is given a lot of attention.

### **Stress Granules**

Stress granules (SGs) are an additional example of mRNPs. Stress, such as ultraviolet irradiation, heat shock, oxidative stress, ER stress, viral infection, hypoxia, and energy depletion, induces a cellular stress response ensuring cellular survival. This response mainly affects the translation machinery by turning off general translation of "housekeeping" transcripts to conserve energy

for repair of stress-induced damages (369). This in turn leads to an accumulation of translationally silenced mRNAs, which aggregate into cytoplasmic SGs (360,370-372). Translation of stress-induced transcripts encoding heat shock proteins (HSPs) among others is enhanced and stress-sensitive heat shock transcription factors (HSFs) regulate the stress-induced transcription in a stress-stimuli dependent manner (373,374). HSPs are a highly conserved set of proteins functioning as molecular chaperones that allow cells to adapt to changes in their environment and increasing cell viability in lethal conditions. There are both constitutive and induced HSPs and apart from being involved in protein folding, transport, and degradation, they are also major regulators of apoptosis by binding proteins involved in apoptosome formation and by directly interacting with caspases inhibiting their activity (375,376). SGs are dynamic and reversible structures that as soon as the stress ceases reduce in numbers due to SG fusions and eventually disappear (377). The major functions of SGs are thought to be storing mRNAs and thereby decreasing their degradation; storing important components of signaling pathways; concentrating components involved in translation and promoting the assembly of translation initiation complexes (378). Heat shock-induced cytoplasmic granules were first observed in tomato cells and later in mammalian cells (379,380). Under elevated temperatures the nuclear actin filaments condense, the granularity of the nucleoli is altered, the cytoskeleton is rearranged, and the Golgi apparatus is disrupted (381).

### The SG Formation

Several stress-sensing serine/threonine kinases accountable for initiating the cellular stress response have been identified, each specific for a certain type of stress. Double-stranded RNA-dependent protein kinase (PKR), PKR-like endoplasmic reticulum kinase (PERK/PEK), general control nonrepressed 2 (GCN2), and hemeregulated inhibitor (HRI) are four kinases that in response to different cellular stress phosphorylate the translation initiation factor eIF2 $\alpha$ , which is an important component of the tRNA-complex carrying the first methionine in protein synthesis (382-385). Phosphorylated

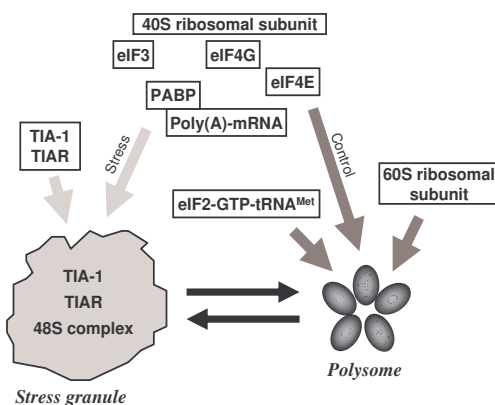

**FIGURE 7. Illustration over some of the factors involved in stress granule formation.** During stress there is always a dynamic equilibrium between stress granules and polysomes. Abbreviations: eIF, eukaryotic initiation factor; PABP, poly(A)-binding protein; S, svedberg unit (ribosomal subunit); TIA-1, t-cell internal antigen-1; TIAR, TIA-1-related protein. Modified from (370).

eIF2 $\alpha$  blocks translation and the resulting stalled ribosomal complex with attached mRNA are readily shuttled to SGs (Figure 7) (360,386,387). This process requires the RNA-binding proteins TIA-1 and TIAR, which act downstreams of eIF2 $\alpha$  phosphorylation and rapidly aggregate upon stress (371,388). The TIA proteins are prominent markers for SGs (387).

### SG Markers

SGs can be distinguished from PBs by the presence of translation initiation factors and ribosome subunits in SGs. In spite of that there are proteins specific for either SGs or PBs, there are many proteins present in both granules suggesting a link between PBs and SGs (360). Indeed, fusions between the two structures have been reported (347,389). No one had until recently managed to purify a SG, but the discovery of the TIA-1/TIAR proteins enabled the identification of many SG components (364). SGs have been found to consist of proteins like exonucleases, scaffold proteins, RNA-binding proteins regulating mRNA structure and function as well as proteins that do not have anything to do with RNA metabolism (360,377). PABPC1 and G3BP are two proteins specifically expressed in SGs (371). Many of the

proteins identified as SG components can function as SG nucleators and induce SG formation when overexpressed. Examples are survival motor neuron protein (390), TIA proteins (391), Fragile X Mental Retardation protein (392), G3BP (347,348), caprin-1, a G3BP1-binding protein (393), and cytoplasmic polyadenylation element-binding protein (389).

### The SG Regulation

There is not much known how stress granule assembly and disassembly is regulated. It is known that both PB and SG formation is promoted by blocking polysomes with for example puromycin and that their dissociation is promoted by stabilizing polysomes with cycloheximide (364). This phenomenon implies that translation must be switched off for mRNA to be able to relocate to SGs and PBs and that polysomes and SGs are in equilibrium during stress (388). In addition, SGs are absent and cannot be induced in mitotic cells due to stabilization of polysomes (394). Several signaling cascades are induced during cellular stress and several of these pathways affect the subcellular distribution of RNA-binding proteins. Activation of the p38 stress-signaling pathway results in phosphorylation, cytoplasmic accumulation and alternative splicing of its downstream targets (395). Grb7 constitutes a family of conserved cytoplasmic adaptor proteins that have been found in SGs. Grb7 couples cell surface receptors with downstream signaling pathways. Grb7 interacts with the focal adhesion kinase (FAK) and FAK-mediated phosphorylation of Grb7 causes Grb7-release from SGs and sequential SG disassembly (396-398). SGs are believed to be connected to apoptotic pathways based upon the fact that SGs have been found to sequester proteins involved in TNF- $\alpha$  signaling and SGs are negatively regulated by the apoptosis-inducing factor (AIF) (399,400). In addition, SG formation has been shown to be dependent on an intact MT network and independent of the actin network (401). An attempt to identify what cellular factors control and/or influence the formation of SGs and/or PBs was recently made by using cells expressing fluorescently tagged SG and PB markers. These cells were thereafter used to study the effect of downregulating different protein expressions on SG and PB formation after stress-

induction (402,403). Approximately 100 factors were found to affect SG formation indicating the complexity of these granules. Furthermore, O-linked N-acetylglucosamine modifications were shown to be of importance for SG formation and blockage of this pathway led to decreased SG formation in response to stress (403). Except for being positive for O-linked N-acetylglucosamine SGs are also positive for ubiquitin speaking for posttranslational modifications systems being closely linked to SGs (403,404).



# The present investigation

## Aim and Introduction

The general aim of this thesis work has been to identify residues important for the neurite-inducing capacity of PKC $\epsilon$  and to investigate by what mechanism PKC $\epsilon$  mediates this property in neuroblastoma cells. A more detailed understanding of the role of PKC $\epsilon$  in morphological differentiation of neuroblastoma cells will help us identify molecular targets that may improve treatment of neuroblastoma patients. Later in the project, the aim came to include elucidating the functional importance of the novel interaction between PKC $\epsilon$  and peripherin, and its relevance for amyotrophic lateral sclerosis, and between PKC $\alpha$  and three RNA-binding proteins, and their involvement in stress granule regulation.

The major focus of the project has been to identify novel PKC-interacting proteins and establish the functional role of the interaction as well as with which specificity the interaction takes place. By determining the interacting motifs in respective proteins, novel therapeutic approaches can be taken to inhibit or facilitate the interaction. The use of selective inhibitors of protein-protein interactions might provide opportunities for subtle modification of cellular function that have different effects than inhibiting the kinase activity of the PKC isozymes. The SK-N-BE(2)C neuroblastoma cell line and the MDA-MB-231 breast carcinoma cell line have been used as a model systems.

The specific aims were:

- ▶ To identify specific amino acids in the C1b domain of PKC $\epsilon$  important for its neurite-inducing effect
- ▶ To characterize the structural and functional importance of the novel interaction between peripherin and PKC $\epsilon$
- ▶ To characterize the structural and functional importance of the novel interactions between G3BP2, PABPC1, and IGF2BP3 and PKC

## Results and Discussion

### **Asn291 and some other residues at the base of the PKC $\epsilon$ C1b domain are crucial for its neurite-inducing capacity (Paper I)**

Inducing differentiation is one approach to slow the growth of neuroblastoma and our group has previously shown that PKC $\epsilon$  induces neurite outgrowth, one feature characteristic for neuronal differentiation (201). The C1b domain has been found to be important for the neuritogenic property of PKC $\epsilon$  and to highlight what residues in the PKC $\epsilon$  C1b domain mediates the effect, we exchanged the  $\epsilon$ C1b domain for the  $\alpha$ C1b domain in the PKC $\epsilon$ PSC1V3 construct creating the PKC $\epsilon$ PSC1 $\alpha$ (C1b)V3 construct. By doing this the PSC1V3 construct loses its neurite-inducing capacity, speaking for the existence of specific structures in the  $\epsilon$ C1b domain that are missing in the  $\alpha$ C1b domain. We therefore aligned the C1b domains from PKC $\epsilon$  and PKC $\alpha$  and found that out of 50 amino acids only 19 amino acids differed. By using the PKC $\epsilon$ PSC1 $\alpha$ (C1b)V3 construct, the 19 residues in the  $\alpha$ C1b domain were mutated one by one to the corresponding residue in the  $\epsilon$ C1b domain and tested for their importance for neurite-induction. Each new mutation was added to the former mutated PKC $\epsilon$ PSC1 $\alpha$ (C1b)V3 construct. Mutating the PKC $\alpha$  residues Asp274, Ser290, and Leu291 into the PKC $\epsilon$  residues Lys274, Pro290, and Asn291 led to a recovered ability of the PSC1V3 construct to induce neurites and introducing the single point mutation L291N was enough to give the  $\epsilon$ PSC1 $\alpha$ (C1b)V3 construct neurite inducing capacity in the presence of TPA although not as potently as wild-type. In addition, mutating Asn291 in the PKC $\epsilon$ PSC1V3 P290S construct into the corresponding PKC $\alpha$  residue led to a pronounced decrease of the number of cells with neurites both with and without TPA. We thereafter used the model made of the PKC $\delta$ C1b domain (27) to construct a three-dimensional model of the PKC $\epsilon$ C1b domain and when studying the model it became evident that the three amino acids Lys274, Pro290, and Asn291 all are positioned in the lower region of the C1b domain opposite the

DAG/phorbol ester binding cleft. The previously described N-terminal motif also seems to be located close to the three important residues in the C1b domain when looking at the folded three-dimensional structure. In conclusion, Asn291 located in the PKC $\epsilon$ C1b domain was identified as an important amino acid for neurite-induction mediated by PKC $\epsilon$ .

### **Peripherin, G3BP2, PABPC1, and IGF2BP3 were identified as novel PKC $\epsilon$ -interacting proteins (Paper II and III)**

We next wanted to elucidate by which mechanism PKC $\epsilon$  induces neurite outgrowth. One hypothesis is that PKC $\epsilon$  mediates this effect by interacting with another protein at the plasma membrane or in close proximity of the membrane. Several screenings have been made and peptide libraries have been manufactured to find novel PKC interaction-partners (405,406). To screen for a novel interacting proteins that putatively could mediate the neurite-inducing effect of PKC $\epsilon$ , we did an immunoprecipitation assay using the most potent neurite-inducing PKC $\epsilon$  construct, the PKC $\epsilon$ PSC1V3 domain, as bait. Mass spectrometry analysis resulted in the identification of several interesting interaction candidates (Table 1), including the class III intermediate filament peripherin and proteins being a part of the translation machinery such as the RNA-binding proteins PABPC1, G3BP2, and IGF2BP3. We next investigated their potential role in PKC $\epsilon$ -mediated neurite outgrowth. However, so far we have not been able to demonstrate any involvement of peripherin, PABPC1, G3BP2, or IGF2BP3 in PKC $\epsilon$ -induced neurite outgrowth. The interactions between PKC $\epsilon$  and the four proteins were confirmed by immunoprecipitation experiments with the endogenous proteins. The interaction between PKC $\epsilon$  and peripherin was shown to be specific. However, it should be mentioned that some interaction could be observed between overexpressed PKC $\eta$  and  $\theta$  and endogenous peripherin, pointing towards the existence of a common structure shared between these PKC isoforms. PABPC1, G3BP2, and IGF2BP3 were shown to interact less specifically with PKC $\epsilon$ . Interactions could be observed with



**TABLE 1. List of identified proteins found in the immunoprecipitation assay with GFP-tagged PKC $\epsilon$ PSC1V3. 13 bands were cut out from a silver stained SDS-PAGE gel, trypsinized, and analyzed by mass spectrometry. Proteins are listed in the order they were identified, beginning with the proteins with smallest size. SIAHBP appeared more than once explaining the different match identities. Peripherin, PABP, G3BP, and IGF2BP3 were chosen for further investigation.**

	Protein	Size	Match	Function
1	Ribosomal protein S3a	30kDa	19%	
2	Ribosomal S0	36kDa	26%	
3	hnRNP E1	41kDa	26%	RNA-binding
4	YB-1	37kDa	40%	transcription factor?
5	eEF1A1	43kDa	26%	regulates translation
6	DDX48	47kDa	18%	unknown
7	Peripherin	54kDa	50%	cytoskeleton
8	G3BP	51kDa	17%	RNA-binding, ribonuclease activity
9	SIAHBP1	54kDa	28-40%	RNA-binding
10	IGF2BP1	64kDa	28%	RNA-binding
11	IGF2BP3	64kDa	27%	RNA-binding
12	PABP1	70kDa	38%	RNA-binding
13	HSP70	74kDa	22%	chaperon
14	ATP dependent DNA Helicase II	83kDa	30%	DNA repair
15	Nucleolin	76kDa	22%	RNA-binding

endogenous PKC $\alpha$  and PKC $\beta$ II as well. They all bound to overexpressed regulatory domain of PKC $\alpha$ ,  $\beta$ ,  $\delta$ , and  $\epsilon$ . PABPC1 did not bind the regulatory domain of PKC $\beta$ . We next show that peripherin binds to the C1b domain of PKC $\epsilon$ . Since we found a functional relationship between PKC $\alpha$  and the interacting RNA-binding proteins we went on with investigating what domain in PKC $\alpha$  mediated the interaction. These interaction experiments point to the C1a domain being the main domain mediating the interaction with PABPC1, G3BP2, and IGF2BP3. However, the C2 domain was also shown to interact with the PABPC1, G3BP2, and IGF2BP3, suggesting that PKC $\alpha$  has many interacting sites or that PKC $\alpha$  is a part of a bigger complex containing the RNA-binding proteins as well as others. The C1 domains have previously been found to mediate both isozymes-specific and -general protein-protein interactions (50,126,138,407). Neither of the novel interactions mentioned here seems to be dependent on the activation status of PKC, since the PKC activator TPA has no effect on the interactions. The functional importance of the interactions was thereafter investigated.

### **PKC $\epsilon$ induces aggregation of peripherin when peripherin levels are increased leading to apoptosis (Paper II)**

Overexpression of peripherin together with PKC $\epsilon$  or in the presence of the PKC activator, TPA, leads to the formation of solid peripherin aggregates which in turn leads to death of the neuroblastoma cells. These novel findings can be of importance in understanding the mechanism behind the neurodegenerative disease ALS, where aggregates containing peripherin are essentially always seen in afflicted motor neurons (257). IF accumulations is a hallmark of both sporadic and familial ALS and understanding the role of the observed IF accumulations could reveal important information about some of the shared pathways between the two ALS types. It is still not known whether the IF accumulations actively participate in the neurodegenerative process, or if they just are a consequence of the pathogenesis. The PRPH gene has been found to be mutated in a few cases of familial ALS and peripherin expression has also been found to be enhanced in affected tissue (232,320,321). However, other genes have also been pointed out to be involved

in the ALS pathogenesis. The SOD1 gene is one example and altering the peripherin expression levels in SOD1-mutated mice does not influence the degree of SOD1-induced pathogenesis in motor neurons. However, this only indicates that peripherin is not playing a central role in motor neuron degeneration caused by SOD1 mutations but might very well have an important role in other pathways leading to ALS (171).

Without any induction of aggregation, overexpression of peripherin does not in itself lead to cell death of neuroblastoma cells. However, it should be noted that an overactivation of PKC induced by high concentrations of TPA has been shown to cause neurodegeneration (408). However, the same phenomena could not be seen with lower TPA concentrations (408) and we have not observed any increased cell death during long-time exposure of TPA. Downregulating PKC $\epsilon$  expression by using silencing RNA (siRNA) targeted towards PKC $\epsilon$  leads to a reduction of cells with peripherin aggregates. Why this reduction is not complete, could either be due to the incomplete knockdown of PKC $\epsilon$  or by the fact that peripherin also binds other novel PKCs which might have compensating functions. A decreased amount of cells containing peripherin aggregates can also be observed when inhibiting PKC activity or by co-expressing the peripherin-interacting domain of PKC $\epsilon$ . By having a more detailed understanding of the function and molecular basis of the interaction between PKC $\epsilon$  and peripherin we hope to find tools that prevent or interfere with pathological processes of importance for ALS such as peripherin aggregation.

### **PKC $\epsilon$ does not induce aggregation of vimentin, a close relative to peripherin, when vimentin levels are increased (Paper II)**

We have also investigated whether PKC $\epsilon$  had the same effect on vimentin, a related type III IF protein (159), or if this effect was peripherin specific. Vimentin has previously been shown to interact with PKC $\epsilon$  (409) and here we show that vimentin interacts with the same PKC $\epsilon$  region as peripherin encompassing the pseudosubstrate, C1 domains and V3 domain. However, activation of PKC did not lead to aggregation of overexpressed

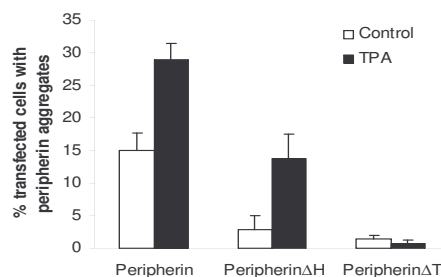

**FIGURE 8. Deletion of either head or tail domain of peripherin decreases TPA-induced peripherin aggregation.** Deletion of the tail has a more pronounced effect on the TPA-effect than deletion of the head.

vimentin. In addition, punctuate structures formed when exogenous vimentin mutants are expressed (409) did not contain peripherin and were not affected by exposure to TPA, indicating that these vimentin structures were distinct from the peripherin. Both we and others have shown that increasing the levels of peripherin enhances its tendency to aggregate (410). Much research has been done to investigate the self-assembling capacity of the IF proteins and disruption of this capacity often leads to the accumulation of the proteins in aggregates. We further investigated the role of the head respectively tail domain of peripherin in peripherin aggregation and we found that deleting either the head or the tail domain of peripherin both decrease the propensity of peripherin to aggregate (Figure 8). However, whereas the deletion of the tail domain completely abolishes the aggregating capacity in the presence of TPA, deleting the head domain only leads to a minor decrease of the amount of cells with peripherin aggregates after TPA treatment. The N-terminal head of peripherin has been shown to be essential for peripherin self-assembly and tailless peripherin protein can self-assemble into filament bundles (411,412). Deleting the C-terminal together with parts of the central rod domain of the IF proteins disrupts the self-assembling capacity and results in aggregate formation (413).

### **None of the PKC-interacting proteins have so far been confirmed to PKC substrates (Paper II and III)**

Many PKC-interacting proteins are PKC substrates. Since TPA had a potentiating and GF109203X had an inhibiting effect on peripherin aggregation, we hypothesized that PKC $\epsilon$ -dependent phosphorylation of peripherin could be a determining factor for peripherin aggregation. However, we have so far not been able to demonstrate an increase of peripherin phosphorylation after PKC activation though this has been shown in PC12 cells (242). The dependence on PKC kinase activity may be explained by the presence of another protein promoting peripherin aggregation when phosphorylated by PKC $\epsilon$ . We have so far not been able to demonstrate any increased phosphorylation status for PABPC1, G3BP2, or IGF2BP3 either after PKC activation. Phosphorylation of G3BP1 has been shown to influence both its internal RNase activity and its subcellular localization and one phosphorylation site has been found for casein kinase II (343,344). Both PABPC1 and translation initiation factors are known phosphoproteins, where phosphorylation regulates the protein-protein-interactions as well as the protein-mRNA-interactions. Hypophosphorylated PABPC1 binds less efficient to poly(A) mRNA and depending on the level of phosphorylation PABPC1 attracts different sets of initiation factors (414). However, how PABPC1 is phosphorylated is not known. The MKK-2/ERK pathway has been implicated to be one possible pathway regulating PABPC1 phosphorylation (415). Whether IGF2BPs are regulated by phosphorylation remains to be studied. PKC has been shown to, at least in vitro, phosphorylate factors involved in translation initiation as well as elongation (416). It would be interesting to continue investigating more of the proteins detected in our assay. For example, the eEF1A1 protein identified as a PKC $\epsilon$ -interacting protein has in vitro been shown to be phosphorylated by PKC $\delta$  (417).

### **G3BP2, PABP1, and IGF2BP3 PKC $\alpha$ , are crucial for stress granule formation (Paper III)**

The three RNA-binding proteins were all found

to relocate to stress granules induced by 44°C heat shock in SK-N-BE(2)C neuroblastoma cells and MDA-MB-231 breast carcinoma cells, as have been previously shown in other cell types (359,364). Heat shock is a commonly used stress inducer and temperatures ranging from 42-45°C have been used to stress cells (359,371). We have also induced SGs using the proteasome inhibitor MG-132 in SK-N-BE(2)C neuroblastoma cells and MDA-MB-231 breast carcinoma cells, consistent with prior reports (418). Both PABPC1 and G3BP2 were used as stress granule markers, since they have been shown to be specific for stress granules (364). However, the antibody used for G3BP2 does not distinguish between G3BP2a and G3BP2b variants. In spite of that PABPC1, G3BP2, and IGF2BP3 were found in a co-immunoprecipitation assay using PKC $\epsilon$ , to our surprise, PKC $\alpha$  was the predominant PKC isoform localizing to the stress granules during heat shock. However, G3BP2a has previously been found to be a component of an mRNP also containing active PKC $\beta$ II and RACK-1 and PKC $\beta$ II has been shown to have a translation regulatory function by interacting directly to ribosomes and via associating with RACK1 (416,419). The PKCs have been previously shown to be important stress sensors. Both PKC $\epsilon$  and PKC $\gamma$  have protective roles against decreased oxygen levels during stroke, neural and cardiac ischemia (420-422). PKC $\theta$  has been shown to be important during ER stress or amino acid deprivation, having a crucial role in the formation of autophagosomes that are formed during the cellular response (423). In addition to interacting with PKC $\alpha$ , we saw that each RNA-binding protein seems to bind to each other or at least exist in the same complex. IGF2BP1 has previously been shown to associate RNA-dependently with G3BP1 and HuD, another RNA-binding protein (424).

### **PKC $\alpha$ , G3BP2, and PABP1 are crucial for stress granule formation (Paper III)**

When we downregulated G3BP2, fewer cells with heat shock-induced SGs in neuroblastoma cells could be observed. In neuroblastoma cells, knockdown of either PABPC1 or IGF2BP3 had no effect on the SG forming ability. However, knockdown of both G3BP2 and PABPC1 in

breast carcinoma cells reduced the amount of cells with heat shock-induced SGs. Silencing of the IGF2BP homologue ZBP1 has previously been shown not to affect assembly or structure of SGs (359). Finding PKC in stress granules implicates PKC being involved in mRNA-regulation during stress. We therefore investigated whether downregulation of PKC $\alpha$  would have any effect on the ability of cells to form SGs during heat shock. When downregulating PKC $\alpha$  expression by siRNA targeted to PKC $\alpha$  in breast carcinoma cells, a pronounced decrease of SG-containing cells during heat shock could be detected. However, due to difficulties of downregulating PKC $\alpha$  by siRNA in SK-N-BE(2)C we could not investigate the role of PKC $\alpha$  in SG formation in these cells. So far the complete picture of the mechanisms behind SG assembly is lacking, but PKC $\alpha$  can be added to the list of proteins shown to affect SG formation.

PKC has previously been shown to be involved in other aspects of mRNA regulation. For example, PKC has in several studies been shown to increase mRNA stability when activated (425-427). Neither PKC activation nor PKC inhibition has any effect on the assembly or disassembly of SGs and we, as well as others (364), have not observed that TPA treatment in itself induce the formation of SGs. The exact function of SGs is not well understood. SGs are thought to sequester specific mRNA under stress and in that way repressing translation of some mRNA and facilitating translation of other mRNA. However, cells that are unable to form SGs are still able to repress translation (404), speaking for SGs having additional roles. Several questions remain to be answered concerning whether SGs play any role in RNA silencing under normal physiological conditions and whether SGs induced by different stimuli contain the same or different components. Neither does one know how the formation of SGs affects cell vitality and protein synthesis.

## Conclusions

- ▶ Residues at the base of the PKC $\epsilon$  C1b domain, especially Asn291, are essential for the neurite-inducing capacity of PKC $\epsilon$
- ▶ Peripherin was found as a novel PKC $\epsilon$ -interacting protein and either increased PKC $\epsilon$ -levels or PKC activation mediates peripherin aggregation. Induced peripherin aggregation also leads to increased cell death.
- ▶ The RNA-binding proteins G3BP2, PABPC1, and IGF2BP3 were found to be novel PKC $\alpha$ -interacting proteins that relocate to stress granules under stress. Knockdown of G3BP2, PABPC1 or PKC $\alpha$  block stress granule formation during cellular stress.
- ▶ Neither peripherin nor the RNA-binding proteins found in the PKC $\epsilon$ -interaction assay affect PKC $\epsilon$ -induced neurite outgrowth.

## Popularized Summary in Swedish

När jag påbörjade mitt projekt var målet att undersöka och identifiera mekanismerna som ligger bakom hur en nervcell bildar utskott. För att undersöka detta, använde jag mig av neuroblastomceller som ser ut som omogna nervceller, det vill säga de saknar längre utskott. Neuroblastom är en barncancer som drabbar 10-15 barn i Sverige varje år. Neuroblastom är en elakartad tumör som trots förbättrad behandling fortfarande har dålig prognos. Som namnet antyder uppstår neuroblastom i nervsystemet och tumörerna kan vara lokaliserade var som helst längs med ryggraden och kan därifrån sprida sig till skelett, lever, lymfkörtlar och benmärg. I vår forskning försöker vi få neuroblastomcellerna att mogna ut, få dem att likna normala nervceller och på så vis förlora sina maligna egenskaper. Under den normala utvecklingen av nervsystemet, utvecklas mogna nervceller med utskott från omogna nervceller som saknar utskott. Utskotten kommer senare att utgör nerverna.

Vi har i vår forskning tidigare sett att om man ökar nivåerna av ett visst protein, protein kinas C epsilon (PKCε), i neuroblastomcellerna, utvecklar dessa utskott liknande de som finns hos normala nervceller. Neuroblastomcellernas utseende blir alltså mer likt en mogen nervcell. Hur PKC epsilon får neuroblastomcellerna att göra detta är oklart, därför har mitt projekt fokuserat på att förstå mekanismerna bakom PKC epsilons förmåga. En mer ingående vetenskap om den bakomliggande mekanismen för utvecklingen av ett nervcellskott skulle dels gagna utvecklingen av bättre behandlingspreparat för barn med neuroblastom och dels användas till att förbättra behandlingen av nervskador. Nervtrådar regenereras sällan vid skador, men om man vet hur man ska göra för att få en nervcell att växa ett utskott, skulle denna vetenskap även kunna appliceras här.

Jag har i mitt första arbete identifierat tre aminosyror som är nödvändiga för PKC epsilons förmåga att få neuroblastomcellerna att växa utskott. Bakgrunden till arbete två, bygger på en teori om att PKC epsilon förmedlar dess effekt genom att binda till ett annat proteins. Teorin undersöktes genom att ta reda på vilka protein som band till den minsta delen av PKC epsilon som vi tidigare sett är tillräcklig för att få neuroblastomcellerna att växa utskott. I detta experimentet hittade jag många olika proteiner som band PKCε bland annat ett protein kallat periferin, som bidrar till struktur och stabilitet i nervceller, och tre andra proteiner som alla binder till RNA, det vill säga den kod som bestämmer vilket protein som ska framställas i cellen. I mitt andra arbete såg jag närmare på bindningen mellan PKC epsilon och periferin. Det visade sig att om man ökar nivåerna av PKC epsilon samtidigt som nivåerna av periferin är förhöjda bildar periferin klumpar inne i cellerna istället för trådar som det normalt gör. Sådana här klumpar kan man även se i nervcellerna hos patienter med sjukdomen amyotrofisk lateralskleros (ALS). ALS är en snabb, neurodegenerativ sjukdom som drabbar vuxna. Sjukdomen har ett förlopp som involverar en gradvis död av de drabbade nervcellerna. Än så länge vet man inte om de periferininnehållande klumparna bidrar till nervcellsdöden. Vi har emellertid påvisat att en ökning av dessa klumpar leder till en ökad celldöd. En fullständig överblick av händelseförloppet skulle öppna dörren för nya behandlingar av ALS. I mitt tredje arbete, undersökte vi funktionen för bindningen mellan PKCε och de RNA-bindande proteinen. Tidigt visade det sig att de RNA-bindande proteinen var viktiga komponenter i speciella ansamlingar av RNA och proteiner som bildas när celler utsätts för andra miljöer än de är vana vid, till exempel om man ökar temperaturen till mer än 37 grader. Dessutom visade det sig att en annan form av PKC, PKC alfa (PKCα), huvudsakligen finns i de här protein-RNA-ansamlingarna vid ökade temperaturer. Vi har sett att även PKC alfa binder de RNA-bindande proteinerna och att utan PKC alfa kan inte cellerna bilda protein-RNA-ansamlingarna. Vi har alltså funnit två nya funktioner för PKC. Däremot kvarstår frågan om vilka proteiner som bidrar till PKC epsilons förmåga att få neuroblastomcellerna att bilda utskott.

## Acknowledgements

First I want to thank Christer for always being there, for always helping with any scientific problems or questions no matter what, being super busy, away on a meeting, on vacation or at home. You have provided a challenging environment, stimulating me to always do my best and think creatively. You have allowed me to be as self-going as I have wanted to be at the same time as you have always showed your interest for everything I was doing. I couldn't have wished for a better supervisor.

I want to thank Sven for all encouraging conversations, for believing in me, for all scientific as well as cultural conversations, and for being as fond of "fastlagsbullar" as I am. I want to thank Håkan for your delightful sense of humor, for knowing exactly how to tease me and for trusting my scientific knowledge.

I want to thank all past and present members of the PKC group for making the PKC group a great team to be a part of. I especially want to thank Helena for being a wonderful person, for always making me feel better, for being an excellent adversary in discussions and for being a great friend; and Gry for always thinking of me (treating me on freshly baked buns, taking me out for ice-cream in the sun, having games-nights or just watching films), for being a real good companion on conferences and for always giving me sensible answers to all my questions, work-related or otherwise. I also want to thank Tamae for helping me with the energy-draining work of IPs and for coming up with fresh, new ideas and Kasia for all clever comments. Last but not least I want to thank past members, Anna, Hanna, Mia, and Ulrika, who all made my time in the PKC group special.

Past and present members, Ami, Anders, Anna, Anna-Karin, Annika, Azzar, Caroline B, Elise, Esther, Eva, Göran, Helén N, Helen P, Jenny K, Jenny P, Karin, Karolina, Katja, Kris, Linda, Maite, Maria, Marica, Marie O, Martin, Nic, Pontus, Rebecka, Sofie J, Sophie L, Sofie N, Stina, Sugata, Temesgen, Tina, Tobias, Ulla, Åsa, of the Center for Molecular Pathology has really contributed to making CMP a workplace you want to go to when you wake up in the morning. You have all made the Christmas lunches, excursions, breakfasts, Book Club meetings, Friday pubs, and parties to events to remember. However, there are a few people I especially want to mention. I want to thank Erik for always managing to surprise me, for making me happy when I need it and for teaching me so many things from computer programming to making the best vegetarian meals there are; Jonas for being someone who I can speak my mind to without any filter, for having an extraordinary way to always know what to say when I feel sad and for sharing great Swedish sport moments with me; Alexander for encouraging my quirkiness and for cycling even though you don't want to; Siv for always believing in



me, for being someone I can talk to no matter what and for always being there; Marie S for being a good friend and for having made Wednesdays to the best day in the week; Matilda for being a great room mate and for always caring; Elisabet for always taking your time to help and for making the lab a better place; Kristin and Iréne for helping with all administrative business and always being a helping hand in need. I also want to thank Cecilia and Jeanette at former Ex-Pat for being great friends and for keeping me fit, whether going swimming or going to the gym!

I want to thank all of my friends outside of work and take the opportunity to apologize for not phoning more often! You know I care and think of you always! I'm really proud of having such a versatile set of friends. I want to thank my course mates from Biomedicine, Caroline, Salina, Elin, Rebecka, and Sara, for sharing scientific dreams and aspirations and for being the kind of friends that lasts a lifetime; my old "gymnasie"-friends Anna and Kristina for standing by me in good and bad times, for being someone to laugh and cry with, for bringing the best out of me; my oldest friends; my "Trelleborgs"-friends, Jonna, Kim, Rebecca, and Suzana, for always being there, for bringing other worlds into mine and for always reminding me about all fun things we've done so far and for all things we're going to do in the future; and, all of my German New Zealand-friends, Bergit, Ulrike, Henning, David, and Malte as well as Timo, for coming into my life, being wonderful people and for making my life sooo much better! Someday I hope we all live at the same place once more!

If I have forgotten someone, please don't be mad -I didn't mean it!

I couldn't have done any of this without my family! I want to thank my brother, Henning, for helping me nourish my other interests outside the scientific world and for always looking out for me. I especially want to thank "Mamma" and "Far" for always supporting me in everything I do, for always encouraging me to do my best, for always having the time to listen, and for all hugs that lift me up when I'm down. There are no words to describe how much you mean to me!

*I also want to send a special thank you to Lotta Kühlhorn, designer, for giving me the pattern I used as template to the cover.*

This work was supported by the Swedish Cancer Society; the Children's Cancer Foundation of Sweden; the Swedish Research Council; the Faculty of Medicine; the Royal Physiographic Society of Lund, the Crafoord; Gunnar, Arvid and Elisabeth Nilsson; Ollie and Elof Ericsson Foundations and Greta and Johan Kock Foundations; and, Malmö University Hospital Research Funds.



## References

1. Takai, Y., Yamamoto, M., Inoue, M., Kishimoto, A., and Nishizuka, Y. (1977) A proenzyme of cyclic nucleotide-independent protein kinase and its activation by calcium-dependent neutral protease from rat liver. *Biochem Biophys Res Commun* **77**, 542-550
2. Takai, Y., Kishimoto, A., Iwasa, Y., Kawahara, Y., Mori, T., and Nishizuka, Y. (1979) Calcium-dependent activation of a multifunctional protein kinase by membrane phospholipids. *J Biol Chem* **254**, 3692-3695
3. Takai, Y., Kishimoto, A., Kikkawa, U., Mori, T., and Nishizuka, Y. (1979) Unsaturated diacylglycerol as a possible messenger for the activation of calcium-activated, phospholipid-dependent protein kinase system. *Biochem Biophys Res Commun* **91**, 1218-1224
4. Cameron, A. J., De Rycker, M., Calleja, V., Alcor, D., Kjaer, S., Kostecky, B., Saurin, A., Faisal, A., Laguerre, M., Hemmings, B. A., McDonald, N., Larijani, B., and Parker, P. J. (2007) Protein kinases, from B to C. *Biochem Soc Trans* **35**, 1013-1017
5. Hanks, S. K., and Hunter, T. (1995) Protein kinases 6. The eukaryotic protein kinase superfamily: kinase (catalytic) domain structure and classification. *Faseb J* **9**, 576-596
6. Newton, A. C. (2003) Regulation of the ABC kinases by phosphorylation: protein kinase C as a paradigm. *Biochem J* **370**, 361-371
7. Kazanietz, M. G. (2005) Targeting protein kinase C and "non-kinase" phorbol ester receptors: Emerging concepts and therapeutic implications. *Biochim Biophys Acta* **1754**, 296-304
8. Newton, A. C. (1995) Protein kinase C: structure, function, and regulation. *J Biol Chem* **270**, 28495-28498
9. Newton, A. C. (1997) Regulation of protein kinase C. *Current opinion in cell biology* **9**, 161-167
10. Parker, P. J., Coussens, L., Totty, N., Rhee, L., Young, S., Chen, E., Stabel, S., Waterfield, M. D., and Ullrich, A. (1986) The complete primary structure of protein kinase C--the major phorbol ester receptor. *Science* **233**, 853-859
11. Liu, W. S., and Heckman, C. A. (1998) The sevenfold way of PKC regulation. *Cell Signal* **10**, 529-542
12. Mellor, H., and Parker, P. J. (1998) The extended protein kinase C superfamily. *Biochem J* **332** ( Pt 2), 281-292
13. Knopf, J. L., Lee, M. H., Sultzman, L. A., Kriz, R. W., Loomis, C. R., Hewick, R. M., and Bell, R. M. (1986) Cloning and expression of multiple protein kinase C cDNAs. *Cell* **46**, 491-502
14. Coussens, L., Rhee, L., Parker, P. J., and Ullrich, A. (1987) Alternative splicing increases the diversity of the human protein kinase C family. *DNA (Mary Ann Liebert, Inc)* **6**, 389-394
15. Ono, Y., Fujii, T., Ogita, K., Kikkawa, U., Igarashi, K., and Nishizuka, Y. (1987) Identification of three additional members of rat protein kinase C family: delta-, epsilon- and zeta-subspecies. *FEBS Lett* **226**, 125-128
16. Palmer, R. H., and Parker, P. J. (1995) Expression, purification and characterization of the ubiquitous protein kinase C-related kinase I. *Biochem J* **309** ( Pt 1), 315-320
17. Johannes, F. J., Prestle, J., Eis, S., Oberhagemann, P., and Pfizenmaier, K. (1994) PKC $\epsilon$  is a novel, atypical member of the protein kinase C family. *J Biol Chem* **269**, 6140-6148
18. Valverde, A. M., Sinnett-Smith, J., Van Lint, J., and Rozengurt, E. (1994) Molecular cloning and characterization of protein kinase D: a target for diacylglycerol and phorbol esters with a distinctive catalytic domain. *Proc Natl Acad Sci U S A* **91**, 8572-8576
19. Hurley, J. H. (2006) Membrane binding domains. *Biochim Biophys Acta* **1761**, 805-811
20. Littler, D. R., Walker, J. R., She, Y. M., Finerty, P. J., Jr., Newman, E. M., and Dhe-Paganon, S. (2006) Structure of human protein kinase C  $\epsilon$  (PKC $\epsilon$ ) C2 domain and identification of phosphorylation sites. *Biochem Biophys Res Commun* **349**, 1182-1189
21. Ochoa, W. F., Garcia-Garcia, J., Fita, I., Corbalan-Garcia, S., Verdaguer, N., and Gomez-Fernandez, J. C. (2001) Structure of the C2 domain from novel protein kinase C $\epsilon$ . A membrane binding model for Ca(2+)-independent C2 domains. *J Mol Biol* **311**, 837-849

22. Pappa, H., Murray-Rust, J., Dekker, L. V., Parker, P. J., and McDonald, N. Q. (1998) Crystal structure of the C2 domain from protein kinase C-delta. *Structure* **6**, 885-894
23. Sutton, R. B., and Sprang, S. R. (1998) Structure of the protein kinase Cbeta phospholipid-binding C2 domain complexed with Ca<sup>2+</sup>. *Structure* **6**, 1395-1405
24. Verdaguer, N., Corbalan-Garcia, S., Ochoa, W. F., Fita, I., and Gomez-Fernandez, J. C. (1999) Ca(2+) bridges the C2 membrane-binding domain of protein kinase Calpha directly to phosphatidylserine. *Embo J* **18**, 6329-6338
25. Hommel, U., Zurini, M., and Luyten, M. (1994) Solution structure of a cysteine rich domain of rat protein kinase C. *Nature structural biology* **1**, 383-387
26. Xu, R. X., Pawelczyk, T., Xia, T. H., and Brown, S. C. (1997) NMR structure of a protein kinase C-gamma phorbol-binding domain and study of protein-lipid micelle interactions. *Biochemistry* **36**, 10709-10717
27. Zhang, G., Kazanietz, M. G., Blumberg, P. M., and Hurley, J. H. (1995) Crystal structure of the cys2 activator-binding domain of protein kinase C delta in complex with phorbol ester. *Cell* **81**, 917-924
28. Solodukhin, A. S., Kretsinger, R. H., and Sando, J. J. (2007) Initial three-dimensional reconstructions of protein kinase C delta from two-dimensional crystals on lipid monolayers. *Cell Signal* **19**, 2035-2045
29. House, C., and Kemp, B. E. (1987) Protein kinase C contains a pseudosubstrate prototope in its regulatory domain. *Science* **238**, 1726-1728
30. Kheifets, V., and Mochly-Rosen, D. (2007) Insight into intra- and inter-molecular interactions of PKC: design of specific modulators of kinase function. *Pharmacol Res* **55**, 467-476
31. Nishizuka, Y. (1988) Studies and perspectives of protein kinase C in signal transduction. *Nippon Ketsueki Gakkai Zasshi* **51**, 1321-1326
32. Colon-Gonzalez, F., and Kazanietz, M. G. (2006) C1 domains exposed: from diacylglycerol binding to protein-protein interactions. *Biochim Biophys Acta* **1761**, 827-837
33. Hall, C., Lim, L., and Leung, T. (2005) C1, see them all. *Trends Biochem Sci* **30**, 169-171
34. Hurley, J. H., Newton, A. C., Parker, P. J., Blumberg, P. M., and Nishizuka, Y. (1997) Taxonomy and function of C1 protein kinase C homology domains. *Protein Sci* **6**, 477-480
35. Cho, W. (2001) Membrane targeting by C1 and C2 domains. *J Biol Chem* **276**, 32407-32410
36. Kazanietz, M. G., Barchi, J. J., Jr., Omichinski, J. G., and Blumberg, P. M. (1995) Low affinity binding of phorbol esters to protein kinase C and its recombinant cysteine-rich region in the absence of phospholipids. *J Biol Chem* **270**, 14679-14684
37. Newton, A. C. (1995) Protein kinase C. Seeing two domains. *Curr Biol* **5**, 973-976
38. Mosior, M., and Newton, A. C. (1995) Mechanism of interaction of protein kinase C with phorbol esters. Reversibility and nature of membrane association. *J Biol Chem* **270**, 25526-25533
39. Anantharayanan, B., Stahelin, R. V., Digman, M. A., and Cho, W. (2003) Activation mechanisms of conventional protein kinase C isoforms are determined by the ligand affinity and conformational flexibility of their C1 domains. *J Biol Chem* **278**, 46886-46894
40. Giorgione, J., Hysell, M., Harvey, D. F., and Newton, A. C. (2003) Contribution of the C1A and C1B domains to the membrane interaction of protein kinase C. *Biochemistry* **42**, 11194-11202
41. Stahelin, R. V., Digman, M. A., Medkova, M., Anantharayanan, B., Rafter, J. D., Melowic, H. R., and Cho, W. (2004) Mechanism of diacylglycerol-induced membrane targeting and activation of protein kinase Cdelta. *J Biol Chem* **279**, 29501-29512
42. Stahelin, R. V., Digman, M. A., Medkova, M., Anantharayanan, B., Melowic, H. R., Rafter, J. D., and Cho, W. (2005) Diacylglycerol-induced membrane targeting and activation of protein kinase Cepsilon: mechanistic differences between protein kinases Cdelta and Cepsilon. *J Biol Chem* **280**, 19784-19793
43. Mott, H. R., Carpenter, J. W., Zhong, S., Ghosh, S., Bell, R. M., and Campbell, S. L. (1996) The solution structure of the Raf-1 cysteine-rich domain: a novel ras and phospholipid binding site. *Proc Natl Acad Sci U S A* **93**, 8312-8317
44. Zhou, M., Horita, D. A., Waugh, D. S., Byrd, R. A., and Morrison, D. K. (2002) Solution structure and functional analysis of the cysteine-rich C1 domain of kinase suppressor of Ras (KSR). *J Mol Biol* **315**, 435-446
45. Pu, Y., Peach, M. L., Garfield, S. H., Wincovitch, S., Marquez, V. E., and Blumberg, P. M. (2006)

- Effects on ligand interaction and membrane translocation of the positively charged arginine residues situated along the C1 domain binding cleft in the atypical protein kinase C isoforms. *J Biol Chem* **281**, 33773-33788
46. Ahmed, S., Kozma, R., Monfries, C., Hall, C., Lim, H. H., Smith, P., and Lim, L. (1990) Human brain n-chimaerin cDNA encodes a novel phorbol ester receptor. *Biochem J* **272**, 767-773
  47. Oliva, J. L., Griner, E. M., and Kazanietz, M. G. (2005) PKC isozymes and diacylglycerol-regulated proteins as effectors of growth factor receptors. *Growth Factors* **23**, 245-252
  48. Yang, C., and Kazanietz, M. G. (2003) Divergence and complexities in DAG signaling: looking beyond PKC. *Trends Pharmacol Sci* **24**, 602-608
  49. Brose, N., and Rosenmund, C. (2002) Move over protein kinase C, you've got company: alternative cellular effectors of diacylglycerol and phorbol esters. *J Cell Sci* **115**, 4399-4411
  50. Yao, L., Suzuki, H., Ozawa, K., Deng, J., Lehel, C., Fukamachi, H., Anderson, W. B., Kawakami, Y., and Kawakami, T. (1997) Interactions between protein kinase C and pleckstrin homology domains. Inhibition by phosphatidylinositol 4,5-bisphosphate and phorbol 12-myristate 13-acetate. *J Biol Chem* **272**, 13033-13039
  51. Sossin, W. S., and Schwartz, J. H. (1993) Ca(2+)-independent protein kinase Cs contain an amino-terminal domain similar to the C2 consensus sequence. *Trends Biochem Sci* **18**, 207-208
  52. Bazzi, M. D., and Nelsestuen, G. L. (1987) Association of protein kinase C with phospholipid vesicles. *Biochemistry* **26**, 115-122
  53. Kohout, S. C., Corbalan-Garcia, S., Torrecillas, A., Gomez-Fernandez, J. C., and Falke, J. J. (2002) C2 domains of protein kinase C isoforms alpha, beta, and gamma: activation parameters and calcium stoichiometries of the membrane-bound state. *Biochemistry* **41**, 11411-11424
  54. Leinweber, B., Parissenti, A. M., Gallant, C., Gangopadhyay, S. S., Kirwan-Rhude, A., Leavis, P. C., and Morgan, K. G. (2000) Regulation of protein kinase C by the cytoskeletal protein calponin. *J Biol Chem* **275**, 40329-40336
  55. Corbalan-Garcia, S., and Gomez-Fernandez, J. C. (2006) Protein kinase C regulatory domains: the art of decoding many different signals in membranes. *Biochim Biophys Acta* **1761**, 633-654
  56. Xu, Z. B., Chaudhary, D., Olland, S., Wolfrom, S., Czerwinski, R., Malakian, K., Lin, L., Stahl, M. L., Joseph-McCarthy, D., Benander, C., Fitz, L., Greco, R., Somers, W. S., and Mosyak, L. (2004) Catalytic domain crystal structure of protein kinase C-theta (PKCtheta). *J Biol Chem* **279**, 50401-50409
  57. Ohno, S., Konno, Y., Akita, Y., Yano, A., and Suzuki, K. (1990) A point mutation at the putative ATP-binding site of protein kinase C alpha abolishes the kinase activity and renders it down-regulation-insensitive. A molecular link between autophosphorylation and down-regulation. *J Biol Chem* **265**, 6296-6300
  58. DeVries, T. A., Neville, M. C., and Reyland, M. E. (2002) Nuclear import of PKCdelta is required for apoptosis: identification of a novel nuclear import sequence. *Embo J* **21**, 6050-6060
  59. Stensman, H., and Larsson, C. (2007) Identification of acidic amino acid residues in the protein kinase C alpha V5 domain that contribute to its insensitivity to diacylglycerol. *J Biol Chem* **282**, 28627-28638
  60. Florin-Christensen, J., Florin-Christensen, M., Delfino, J. M., Stegmann, T., and Rasmussen, H. (1992) Metabolic fate of plasma membrane diacylglycerols in NIH 3T3 fibroblasts. *J Biol Chem* **267**, 14783-14789
  61. Goodnight, J. A., Mischak, H., Kolch, W., and Mushinski, J. F. (1995) Immunocytochemical localization of eight protein kinase C isozymes overexpressed in NIH 3T3 fibroblasts. Isoform-specific association with microfilaments, Golgi, endoplasmic reticulum, and nuclear and cell membranes. *J Biol Chem* **270**, 9991-10001
  62. Newton, A. C. (1993) Interaction of proteins with lipid headgroups: lessons from protein kinase C. *Annual review of biophysics and biomolecular structure* **22**, 1-25
  63. Nishizuka, Y. (1984) Turnover of inositol phospholipids and signal transduction. *Science* **225**, 1365-1370
  64. Newton, A. C., and Keranen, L. M. (1994) Phosphatidyl-L-serine is necessary for protein kinase C's high-affinity interaction with diacylglycerol-containing membranes. *Biochemistry* **33**, 6651-6658
  65. Nalefski, E. A., and Newton, A. C. (2001) Membrane binding kinetics of protein kinase C betaII

- mediated by the C2 domain. *Biochemistry* **40**, 13216-13229
66. Johnson, J. E., Giorgione, J., and Newton, A. C. (2000) The C1 and C2 domains of protein kinase C are independent membrane targeting modules, with specificity for phosphatidylserine conferred by the C1 domain. *Biochemistry* **39**, 11360-11369
  67. Parekh, D. B., Ziegler, W., and Parker, P. J. (2000) Multiple pathways control protein kinase C phosphorylation. *Embo J* **19**, 496-503
  68. Huang, K. P., Chan, K. F., Singh, T. J., Nakabayashi, H., and Huang, F. L. (1986) Autophosphorylation of rat brain Ca<sup>2+</sup>-activated and phospholipid-dependent protein kinase. *J Biol Chem* **261**, 12134-12140
  69. Mochly-Rosen, D., and Koshland, D. E., Jr. (1987) Domain structure and phosphorylation of protein kinase C. *J Biol Chem* **262**, 2291-2297
  70. Keranen, L. M., Dutil, E. M., and Newton, A. C. (1995) Protein kinase C is regulated in vivo by three functionally distinct phosphorylations. *Curr Biol* **5**, 1394-1403
  71. Tsutakawa, S. E., Medzihradsky, K. F., Flint, A. J., Burlingame, A. L., and Koshland, D. E., Jr. (1995) Determination of in vivo phosphorylation sites in protein kinase C. *J Biol Chem* **270**, 26807-26812
  72. Cazaubon, S. M., Ramos-Morales, F., Fischer, S., Schweighoffer, F., Strosberg, A. D., and Couraud, P. O. (1994) Endothelin induces tyrosine phosphorylation and GRB2 association of Shc in astrocytes. *J Biol Chem* **269**, 24805-24809
  73. Orr, J. W., and Newton, A. C. (1994) Intra-peptide regulation of protein kinase C. *J Biol Chem* **269**, 8383-8387
  74. Dutil, E. M., Toker, A., and Newton, A. C. (1998) Regulation of conventional protein kinase C isozymes by phosphoinositide-dependent kinase 1 (PDK-1). *Curr Biol* **8**, 1366-1375
  75. Le Good, J. A., Ziegler, W. H., Parekh, D. B., Alessi, D. R., Cohen, P., and Parker, P. J. (1998) Protein kinase C isotypes controlled by phosphoinositide 3-kinase through the protein kinase PDK1. *Science* **281**, 2042-2045
  76. Newton, A. C. (2001) Protein kinase C: structural and spatial regulation by phosphorylation, cofactors, and macromolecular interactions. *Chem Rev* **101**, 2353-2364
  77. Gao, T., and Newton, A. C. (2002) The turn motif is a phosphorylation switch that regulates the binding of Hsp70 to protein kinase C. *J Biol Chem* **277**, 31585-31592
  78. Gao, T., Toker, A., and Newton, A. C. (2001) The carboxyl terminus of protein kinase c provides a switch to regulate its interaction with the phosphoinositide-dependent kinase, PDK-1. *J Biol Chem* **276**, 19588-19596
  79. Edwards, A. S., and Newton, A. C. (1997) Phosphorylation at conserved carboxyl-terminal hydrophobic motif regulates the catalytic and regulatory domains of protein kinase C. *J Biol Chem* **272**, 18382-18390
  80. Kraft, A. S., Anderson, W. B., Cooper, H. L., and Sando, J. J. (1982) Decrease in cytosolic calcium/phospholipid-dependent protein kinase activity following phorbol ester treatment of EL4 thymoma cells. *J Biol Chem* **257**, 13193-13196
  81. Kishimoto, A., Mikawa, K., Hashimoto, K., Yasuda, I., Tanaka, S., Tominaga, M., Kuroda, T., and Nishizuka, Y. (1989) Limited proteolysis of protein kinase C subspecies by calcium-dependent neutral protease (calpain). *J Biol Chem* **264**, 4088-4092
  82. Leithe, E., Cruciani, V., Sanner, T., Mikalsen, S. O., and Rivedal, E. (2003) Recovery of gap junctional intercellular communication after phorbol ester treatment requires proteasomal degradation of protein kinase C. *Carcinogenesis* **24**, 1239-1245
  83. Areces, L. B., Kazanietz, M. G., and Blumberg, P. M. (1994) Close similarity of baculovirus-expressed n-chimaerin and protein kinase C alpha as phorbol ester receptors. *J Biol Chem* **269**, 19553-19558
  84. Merrill, A. H., Jr. (1991) Cell regulation by sphingosine and more complex sphingolipids. *Journal of bioenergetics and biomembranes* **23**, 83-104
  85. Mochly-Rosen, D., and Gordon, A. S. (1998) Anchoring proteins for protein kinase C: a means for isozyme selectivity. *Faseb J* **12**, 35-42
  86. Johnson, J. A., Gray, M. O., Chen, C. H., and Mochly-Rosen, D. (1996) A protein kinase C translocation inhibitor as an isozyme-selective antagonist of cardiac function. *J Biol Chem* **271**, 24962-24966
  87. Ron, D., Luo, J., and Mochly-Rosen, D. (1995) C2 region-derived peptides inhibit translocation and function of beta protein kinase C in vivo. *J Biol Chem* **270**, 24180-24187

88. Osada, S., Mizuno, K., Saido, T. C., Akita, Y., Suzuki, K., Kuroki, T., and Ohno, S. (1990) A phorbol ester receptor/protein kinase, nPKC  $\epsilon$ , a new member of the protein kinase C family predominantly expressed in lung and skin. *J Biol Chem* **265**, 22434-22440
89. Osada, S., Mizuno, K., Saido, T. C., Suzuki, K., Kuroki, T., and Ohno, S. (1992) A new member of the protein kinase C family, nPKC  $\theta$ , predominantly expressed in skeletal muscle. *Mol Cell Biol* **12**, 3930-3938
90. Wetsel, W. C., Khan, W. A., Merchenthaler, I., Rivera, H., Halpern, A. E., Phung, H. M., Negro-Vilar, A., and Hannun, Y. A. (1992) Tissue and cellular distribution of the extended family of protein kinase C isoenzymes. *J Cell Biol* **117**, 121-133
91. Michie, A. M., and Nakagawa, R. (2005) The link between PKC $\alpha$  regulation and cellular transformation. *Immunology letters* **96**, 155-162
92. Black, J. D. (2000) Protein kinase C-mediated regulation of the cell cycle. *Front Biosci* **5**, D406-423
93. Dempsey, E. C., Newton, A. C., Mochly-Rosen, D., Fields, A. P., Reyland, M. E., Insel, P. A., and Messing, R. O. (2000) Protein kinase C isozymes and the regulation of diverse cell responses. *Am J Physiol Lung Cell Mol Physiol* **279**, L429-438
94. Livneh, E., and Fishman, D. D. (1997) Linking protein kinase C to cell-cycle control. *European journal of biochemistry / FEBS* **248**, 1-9
95. dBudas, G. R., Koyanagi, T., Churchill, E. N., and Mochly-Rosen, D. (2007) Competitive inhibitors and allosteric activators of protein kinase C isoenzymes: a personal account and progress report on transferring academic discoveries to the clinic. *Biochem Soc Trans* **35**, 1021-1026
96. Jaken, S., and Parker, P. J. (2000) Protein kinase C binding partners. *Bioessays* **22**, 245-254
97. Mochly-Rosen, D. (1995) Localization of protein kinases by anchoring proteins: a theme in signal transduction. *Science* **268**, 247-251
98. Acs, P., Wang, Q. J., Bogi, K., Marquez, A. M., Lorenzo, P. S., Biro, T., Szallasi, Z., Mushinski, J. F., and Blumberg, P. M. (1997) Both the catalytic and regulatory domains of protein kinase C chimeras modulate the proliferative properties of NIH 3T3 cells. *J Biol Chem* **272**, 28793-28799
99. Wang, Q. J., Acs, P., Goodnight, J., Blumberg, P. M., Mischak, H., and Mushinski, J. F. (1998) The catalytic domain of PKC- $\epsilon$ , in reciprocal PKC- $\delta$  and - $\epsilon$  chimeras, is responsible for conferring tumorigenicity to NIH3T3 cells, whereas both regulatory and catalytic domains of PKC- $\epsilon$  contribute to in vitro transformation. *Oncogene* **16**, 53-60
100. Zeidman, R., Pettersson, L., Sailaja, P. R., Truedsson, E., Fagerström, S., Pählman, S., and Larsson, C. (1999) Novel and classical protein kinase C isoforms have different functions in proliferation, survival and differentiation of neuroblastoma cells. *Int J Cancer* **81**, 494-501
101. Koivunen, J., Aaltonen, V., Koskela, S., Lehenkari, P., Laato, M., and Peltonen, J. (2004) Protein kinase C  $\alpha/\beta$  inhibitor Go6976 promotes formation of cell junctions and inhibits invasion of urinary bladder carcinoma cells. *Cancer Res* **64**, 5693-5701
102. Pan, Q., Bao, L. W., Teknos, T. N., and Merajver, S. D. (2006) Targeted Disruption of Protein Kinase C { $\epsilon$ } Reduces Cell Invasion and Motility through Inactivation of RhoA and RhoC GTPases in Head and Neck Squamous Cell Carcinoma. *Cancer Res* **66**, 9379-9384
103. Tachado, S. D., Mayhew, M. W., Wescott, G. G., Foreman, T. L., Goodwin, C. D., McJilton, M. A., and Terrian, D. M. (2002) Regulation of tumor invasion and metastasis in protein kinase C  $\epsilon$ -transformed NIH3T3 fibroblasts. *J Cell Biochem* **85**, 785-797
104. Murray, N. R., Davidson, L. A., Chapkin, R. S., Clay Gustafson, W., Schattenberg, D. G., and Fields, A. P. (1999) Overexpression of protein kinase C  $\beta$ 11 induces colonic hyperproliferation and increased sensitivity to colon carcinogenesis. *J Cell Biol* **145**, 699-711
105. Besson, A., Wilson, T. L., and Yong, V. W. (2002) The anchoring protein RACK1 links protein kinase C $\epsilon$  to integrin  $\beta$  chains. Requirements for adhesion and motility. *J Biol Chem* **277**, 22073-22084
106. Cacace, A. M., Guadagno, S. N., Krauss, R. S., Fabbro, D., and Weinstein, I. B. (1993) The  $\epsilon$  isoform of protein kinase C is an oncogene when overexpressed in rat fibroblasts. *Oncogene* **8**, 2095-2104
107. Mischak, H., Goodnight, J. A., Kolch, W., Martiny-Baron, G., Schaehtle, C., Kazanietz, M. G., Blumberg, P. M., Pierce, J. H., and Mushinski, J. F. (1993) Overexpression of protein kinase C- $\delta$  and - $\epsilon$  in NIH 3T3 cells induces opposite effects on growth, morphology, anchorage dependence,



- and tumorigenicity. *J Biol Chem* **268**, 6090-6096
108. Pan, Q., Bao, L. W., Kleer, C. G., Sabel, M. S., Griffith, K. A., Teknos, T. N., and Merajver, S. D. (2005) Protein kinase C epsilon is a predictive biomarker of aggressive breast cancer and a validated target for RNA interference anticancer therapy. *Cancer Res* **65**, 8366-8371
  109. Ways, D. K., Kukoly, C. A., deVente, J., Hooker, J. L., Bryant, W. O., Posekany, K. J., Fletcher, D. J., Cook, P. P., and Parker, P. J. (1995) MCF-7 breast cancer cells transfected with protein kinase C-alpha exhibit altered expression of other protein kinase C isoforms and display a more aggressive neoplastic phenotype. *The Journal of clinical investigation* **95**, 1906-1915
  110. Basu, A., and Sivaprasad, U. (2007) Protein kinase Cepsilon makes the life and death decision. *Cell Signal* **19**, 1633-1642
  111. Mackay, H. J., and Twelves, C. J. (2007) Targeting the protein kinase C family: are we there yet? *Nature reviews* **7**, 554-562
  112. Ding, L., Wang, H., Lang, W., and Xiao, L. (2002) Protein kinase C-epsilon promotes survival of lung cancer cells by suppressing apoptosis through dysregulation of the mitochondrial caspase pathway. *J Biol Chem* **277**, 35305-35313
  113. Jung, Y. S., Ryu, B. R., Lee, B. K., Mook-Jung, I., Kim, S. U., Lee, S. H., Baik, E. J., and Moon, C. H. (2004) Role for PKC-epsilon in neuronal death induced by oxidative stress. *Biochem Biophys Res Commun* **320**, 789-794
  114. Poole, A. W., Pula, G., Hers, I., Crosby, D., and Jones, M. L. (2004) PKC-interacting proteins: from function to pharmacology. *Trends Pharmacol Sci* **25**, 528-535
  115. Mochly-Rosen, D., Khaner, H., Lopez, J., and Smith, B. L. (1991) Intracellular receptors for activated protein kinase C. Identification of a binding site for the enzyme. *J Biol Chem* **266**, 14866-14868
  116. Ron, D., Chen, C. H., Caldwell, J., Jamieson, L., Orr, E., and Mochly-Rosen, D. (1994) Cloning of an intracellular receptor for protein kinase C: a homolog of the beta subunit of G proteins. *Proc Natl Acad Sci U S A* **91**, 839-843
  117. Keenan, C., and Kelleher, D. (1998) Protein kinase C and the cytoskeleton. *Cell Signal* **10**, 225-232
  118. Larsson, C. (2006) Protein kinase C and the regulation of the actin cytoskeleton. *Cell Signal* **18**, 276-284
  119. Anilkumar, N., Parsons, M., Monk, R., Ng, T., and Adams, J. C. (2003) Interaction of fascin and protein kinase Calpha: a novel intersection in cell adhesion and motility. *Embo J* **22**, 5390-5402
  120. Ng, T., Shima, D., Squire, A., Bastiaens, P. I., Gschmeissner, S., Humphries, M. J., and Parker, P. J. (1999) PKCalpha regulates beta1 integrin-dependent cell motility through association and control of integrin traffic. *Embo J* **18**, 3909-3923
  121. Vallentin, A., Lo, T. C., and Joubert, D. (2001) A single point mutation in the V3 region affects protein kinase Calpha targeting and accumulation at cell-cell contacts. *Mol Cell Biol* **21**, 3351-3363
  122. Dovas, A., Yoneda, A., and Couchman, J. R. (2006) PKCbeta-dependent activation of RhoA by syndecan-4 during focal adhesion formation. *J Cell Sci* **119**, 2837-2846
  123. Chen, D., Purohit, A., Halilovic, E., Doxsey, S. J., and Newton, A. C. (2004) Centrosomal anchoring of protein kinase C betaII by pericentrin controls microtubule organization, spindle function, and cytokinesis. *J Biol Chem* **279**, 4829-4839
  124. Benes, C. H., Wu, N., Elia, A. E., Dharia, T., Cantley, L. C., and Soltoff, S. P. (2005) The C2 domain of PKCdelta is a phosphotyrosine binding domain. *Cell* **121**, 271-280
  125. Dekker, L. V., and Parker, P. J. (1997) Regulated binding of the protein kinase C substrate GAP-43 to the VO/C2 region of protein kinase C-delta. *J Biol Chem* **272**, 12747-12753
  126. Sundberg, C., Thodeti, C. K., Kveiborg, M., Larsson, C., Parker, P., Albrechtsen, R., and Wewer, U. M. (2004) Regulation of ADAM12 cell-surface expression by protein kinase C epsilon. *J Biol Chem* **279**, 51601-51611
  127. Blobel, G. C., Stribling, D. S., Fabbro, D., Stabel, S., and Hannun, Y. A. (1996) Protein kinase C beta II specifically binds to and is activated by F-actin. *J Biol Chem* **271**, 15823-15830
  128. Prekeris, R., Hernandez, R. M., Mayhew, M. W., White, M. K., and Terrian, D. M. (1998) Molecular analysis of the interactions between protein kinase C-epsilon and filamentous actin. *J Biol Chem* **273**, 26790-26798
  129. Prekeris, R., Mayhew, M. W., Cooper, J. B., and Terrian, D. M. (1996) Identification and localization of an actin-binding motif that is unique to the epsilon isoform of protein kinase C and participates in

- the regulation of synaptic function. *J Cell Biol* **132**, 77-90
130. Zeidman, R., Troller, U., Raghunath, A., Pählman, S., and Larsson, C. (2002) Protein kinase Cepsilon actin-binding site is important for neurite outgrowth during neuronal differentiation. *Mol Biol Cell* **13**, 12-24
  131. Ping, P., Song, C., Zhang, J., Guo, Y., Cao, X., Li, R. C., Wu, W., Vondriska, T. M., Pass, J. M., Tang, X. L., Pierce, W. M., and Bolli, R. (2002) Formation of protein kinase C(epsilon)-Lck signaling modules confers cardioprotection. *The Journal of clinical investigation* **109**, 499-507
  132. Garcia-Rocha, M., Avila, J., and Lozano, J. (1997) The zeta isozyme of protein kinase C binds to tubulin through the pseudosubstrate domain. *Experimental cell research* **230**, 1-8
  133. Robinson, K., Jones, D., Patel, Y., Martin, H., Madrazo, J., Martin, S., Howell, S., Elmore, M., Finnen, M. J., and Aitken, A. (1994) Mechanism of inhibition of protein kinase C by 14-3-3 isoforms. 14-3-3 isoforms do not have phospholipase A2 activity. *Biochem J* **299** ( Pt 3), 853-861
  134. Tanji, M., Horwitz, R., Rosenfeld, G., and Waymire, J. C. (1994) Activation of protein kinase C by purified bovine brain 14-3-3: comparison with tyrosine hydroxylase activation. *J Neurochem* **63**, 1908-1916
  135. Acs, P., Szallasi, Z., Kazanietz, M. G., and Blumberg, P. M. (1995) Differential activation of PKC isozymes by 14-3-3 zeta protein. *Biochem Biophys Res Commun* **216**, 103-109
  136. Hausser, A., Storz, P., Link, G., Stoll, H., Liu, Y. C., Altman, A., Pfizenmaier, K., and Johannes, F. J. (1999) Protein kinase C mu is negatively regulated by 14-3-3 signal transduction proteins. *J Biol Chem* **274**, 9258-9264
  137. Meller, N., Liu, Y. C., Collins, T. L., Bonnefoy-Berard, N., Baier, G., Isakov, N., and Altman, A. (1996) Direct interaction between protein kinase C theta (PKC theta) and 14-3-3 tau in T cells: 14-3-3 overexpression results in inhibition of PKC theta translocation and function. *Mol Cell Biol* **16**, 5782-5791
  138. Nguyen, T. A., Takemoto, L. J., and Takemoto, D. J. (2004) Inhibition of gap junction activity through the release of the C1B domain of protein kinase Cγ (PKCγ) from 14-3-3: identification of PKCγ-binding sites. *J Biol Chem* **279**, 52714-52725
  139. Johannes, F. J., Hausser, A., Storz, P., Truckenmuller, L., Link, G., Kawakami, T., and Pfizenmaier, K. (1999) Bruton's tyrosine kinase (Btk) associates with protein kinase C mu. *FEBS Lett* **461**, 68-72
  140. Yao, L., Kawakami, Y., and Kawakami, T. (1994) The pleckstrin homology domain of Bruton tyrosine kinase interacts with protein kinase C. *Proc Natl Acad Sci U S A* **91**, 9175-9179
  141. Leitges, M. (2007) Functional PKC in vivo analysis using deficient mouse models. *Biochem Soc Trans* **35**, 1018-1020
  142. Tan, S. L., and Parker, P. J. (2003) Emerging and diverse roles of protein kinase C in immune cell signalling. *Biochem J* **376**, 545-552
  143. Leitges, M., Schmedt, C., Guinamard, R., Davoust, J., Schaal, S., Stabel, S., and Tarakhovsky, A. (1996) Immunodeficiency in protein kinase cbeta-deficient mice. *Science* **273**, 788-791
  144. Sun, Z., Arendt, C. W., Ellmeier, W., Schaeffer, E. M., Sunshine, M. J., Gandhi, L., Annes, J., Petrzilka, D., Kupfer, A., Schwartzberg, P. L., and Littman, D. R. (2000) PKC-theta is required for TCR-induced NF-kappaB activation in mature but not immature T lymphocytes. *Nature* **404**, 402-407
  145. Castrillo, A., Pennington, D. J., Otto, F., Parker, P. J., Owen, M. J., and Bosca, L. (2001) Protein kinase Cepsilon is required for macrophage activation and defense against bacterial infection. *The Journal of experimental medicine* **194**, 1231-1242
  146. Luo, L. (2002) Actin cytoskeleton regulation in neuronal morphogenesis and structural plasticity. *Annu Rev Cell Dev Biol* **18**, 601-635
  147. Arimura, N., and Kaibuchi, K. (2007) Neuronal polarity: from extracellular signals to intracellular mechanisms. *Nat Rev Neurosci* **8**, 194-205
  148. Luo, L. (2000) Rho GTPases in neuronal morphogenesis. *Nat Rev Neurosci* **1**, 173-180
  149. Redmond, L., and Ghosh, A. (2001) The role of Notch and Rho GTPase signaling in the control of dendritic development. *Curr Opin Neurobiol* **11**, 111-117
  150. Lin, X. H., Grako, K. A., Burg, M. A., and Stallcup, W. B. (1996) NG2 proteoglycan and the actin-binding protein fascin define separate populations of actin-containing filopodia and lamellipodia during cell spreading and migration. *Mol Biol Cell* **7**, 1977-1993
  151. Nikolic, M. (2002) The role of Rho GTPases and associated kinases in regulating neurite outgrowth.



152. Takai, Y., Sasaki, T., and Matozaki, T. (2001) Small GTP-binding proteins. *Physiological reviews* **81**, 153-208
153. Hall, A. (1998) Rho GTPases and the actin cytoskeleton. *Science* **279**, 509-514
154. Kozma, R., Ahmed, S., Best, A., and Lim, L. (1995) The Ras-related protein Cdc42Hs and bradykinin promote formation of peripheral actin microspikes and filopodia in Swiss 3T3 fibroblasts. *Mol Cell Biol* **15**, 1942-1952
155. Ridley, A. J., and Hall, A. (1992) The small GTP-binding protein rho regulates the assembly of focal adhesions and actin stress fibers in response to growth factors. *Cell* **70**, 389-399
156. Ridley, A. J., Paterson, H. F., Johnston, C. L., Diekmann, D., and Hall, A. (1992) The small GTP-binding protein rac regulates growth factor-induced membrane ruffling. *Cell* **70**, 401-410
157. Kalman, D., Gomperts, S. N., Hardy, S., Kitamura, M., and Bishop, J. M. (1999) Ras family GTPases control growth of astrocyte processes. *Mol Biol Cell* **10**, 1665-1683
158. Kozma, R., Sarner, S., Ahmed, S., and Lim, L. (1997) Rho family GTPases and neuronal growth cone remodelling: relationship between increased complexity induced by Cdc42Hs, Rac1, and acetylcholine and collapse induced by RhoA and lysophosphatidic acid. *Mol Cell Biol* **17**, 1201-1211
159. Parry, D. A., and Steinert, P. M. (1999) Intermediate filaments: molecular architecture, assembly, dynamics and polymorphism. *Q Rev Biophys* **32**, 99-187
160. Revenu, C., Athman, R., Robine, S., and Louvard, D. (2004) The co-workers of actin filaments: from cell structures to signals. *Nat Rev Mol Cell Biol* **5**, 635-646
161. Schaefer, A. W., Schoonderwoert, V. T., Ji, L., Mederios, N., Danuser, G., and Forscher, P. (2008) Coordination of actin filament and microtubule dynamics during neurite outgrowth. *Dev Cell* **15**, 146-162
162. Suter, D. M., Espindola, F. S., Lin, C. H., Forscher, P., and Mooseker, M. S. (2000) Localization of unconventional myosins V and VI in neuronal growth cones. *J Neurobiol* **42**, 370-382
163. Cochard, P., and Paulin, D. (1984) Initial expression of neurofilaments and vimentin in the central and peripheral nervous system of the mouse embryo in vivo. *J Neurosci* **4**, 2080-2094
164. Undamatla, J., and Szaro, B. G. (2001) Differential expression and localization of neuronal intermediate filament proteins within newly developing neurites in dissociated cultures of *Xenopus laevis* embryonic spinal cord. *Cell Motil Cytoskeleton* **49**, 16-32
165. Bignami, A., Raju, T., and Dahl, D. (1982) Localization of vimentin, the nonspecific intermediate filament protein, in embryonal glia and in early differentiating neurons. In vivo and in vitro immunofluorescence study of the rat embryo with vimentin and neurofilament antisera. *Developmental biology* **91**, 286-295
166. Kaplan, M. P., Chin, S. S., Fliegner, K. H., and Liem, R. K. (1990) Alpha-internexin, a novel neuronal intermediate filament protein, precedes the low molecular weight neurofilament protein (NF-L) in the developing rat brain. *J Neurosci* **10**, 2735-2748
167. Lendahl, U., Zimmerman, L. B., and McKay, R. D. (1990) CNS stem cells express a new class of intermediate filament protein. *Cell* **60**, 585-595
168. Parysek, L. M., and Goldman, R. D. (1987) Characterization of intermediate filaments in PC12 cells. *J Neurosci* **7**, 781-791
169. Shaw, G., and Weber, K. (1982) Differential expression of neurofilament triplet proteins in brain development. *Nature* **298**, 277-279
170. Hoffman, P. N., Cleveland, D. W., Griffin, J. W., Landes, P. W., Cowan, N. J., and Price, D. L. (1987) Neurofilament gene expression: a major determinant of axonal caliber. *Proc Natl Acad Sci U S A* **84**, 3472-3476
171. Larivière, R. C., Beaulieu, J. M., Nguyen, M. D., and Julien, J. P. (2003) Peripherin is not a contributing factor to motor neuron disease in a mouse model of amyotrophic lateral sclerosis caused by mutant superoxide dismutase. *Neurobiology of disease* **13**, 158-166
172. Franke, W. W., Schmid, E., Osborn, M., and Weber, K. (1978) Different intermediate-sized filaments distinguished by immunofluorescence microscopy. *Proc Natl Acad Sci U S A* **75**, 5034-5038
173. Hesse, M., Magin, T. M., and Weber, K. (2001) Genes for intermediate filament proteins and the draft sequence of the human genome: novel keratin genes and a surprisingly high number of pseudogenes related to keratin genes 8 and 18. *J Cell Sci* **114**, 2569-2575

174. Coulombe, P. A., Ma, L., Yamada, S., and Wawersik, M. (2001) Intermediate filaments at a glance. *J Cell Sci* **114**, 4345-4347
175. Herrmann, H., and Aebi, U. (2000) Intermediate filaments and their associates: multi-talented structural elements specifying cytoarchitecture and cytodynamics. *Current opinion in cell biology* **12**, 79-90
176. Foley, J., Ley, C. A., and Parysek, L. M. (1994) The structure of the human peripherin gene (PRPH) and identification of potential regulatory elements. *Genomics* **22**, 456-461
177. Thompson, M. A., and Ziff, E. B. (1989) Structure of the gene encoding peripherin, an NGF-regulated neuronal-specific type III intermediate filament protein. *Neuron* **2**, 1043-1053
178. Fuchs, E., and Weber, K. (1994) Intermediate filaments: structure, dynamics, function, and disease. *Annual review of biochemistry* **63**, 345-382
179. Strelkov, S. V., Herrmann, H., and Aebi, U. (2003) Molecular architecture of intermediate filaments. *Bioessays* **25**, 243-251
180. Chang, L., and Goldman, R. D. (2004) Intermediate filaments mediate cytoskeletal crosstalk. *Nat Rev Mol Cell Biol* **5**, 601-613
181. Coulombe, P. A., and Wong, P. (2004) Cytoplasmic intermediate filaments revealed as dynamic and multipurpose scaffolds. *Nat Cell Biol* **6**, 699-706
182. Helfand, B. T., Chou, Y. H., Shumaker, D. K., and Goldman, R. D. (2005) Intermediate filament proteins participate in signal transduction. *Trends Cell Biol* **15**, 568-570
183. Paramio, J. M., and Jorcano, J. L. (2002) Beyond structure: do intermediate filaments modulate cell signalling? *Bioessays* **24**, 836-844
184. Toivola, D. M., Tao, G. Z., Habtezion, A., Liao, J., and Omary, M. B. (2005) Cellular integrity plus: organelle-related and protein-targeting functions of intermediate filaments. *Trends Cell Biol* **15**, 608-617
185. Mattson, M. P., Guthrie, P. B., and Kater, S. B. (1988) Intracellular messengers in the generation and degeneration of hippocampal neuroarchitecture. *J Neurosci Res* **21**, 447-464
186. Hanada, M., Krajewski, S., Tanaka, S., Cazals-Hatem, D., Spengler, B. A., Ross, R. A., Biedler, J. L., and Reed, J. C. (1993) Regulation of Bcl-2 oncoprotein levels with differentiation of human neuroblastoma cells. *Cancer Res* **53**, 4978-4986
187. Lavenius, E., Gestblom, C., Johansson, I., Nanberg, E., and Pahlman, S. (1995) Transfection of TRK-A into human neuroblastoma cells restores their ability to differentiate in response to nerve growth factor. *Cell Growth Differ* **6**, 727-736
188. Portier, M. M., Croizat, B., and Gros, F. (1982) A sequence of changes in cytoskeletal components during neuroblastoma differentiation. *FEBS Lett* **146**, 283-288
189. Keshelava, N., Zuo, J. J., Waidyaratne, N. S., Triche, T. J., and Reynolds, C. P. (2000) p53 mutations and loss of p53 function confer multidrug resistance in neuroblastoma. *Medical and pediatric oncology* **35**, 563-568
190. Pahlman, S., Ruusala, A. I., Abrahamsson, L., Odelstad, L., and Nilsson, K. (1983) Kinetics and concentration effects of TPA-induced differentiation of cultured human neuroblastoma cells. *Cell differentiation* **12**, 165-170
191. Spinelli, W., Sonnenfeld, K. H., and Ishii, D. N. (1982) Effects of phorbol ester tumor promoters and nerve growth factor on neurite outgrowth in cultured human neuroblastoma cells. *Cancer Res* **42**, 5067-5073
192. Messing, R. O., Henteleff, M., and Park, J. J. (1991) Ethanol enhances growth factor-induced neurite formation in PC12 cells. *Brain Res* **565**, 301-311
193. Messing, R. O., Petersen, P. J., and Henrich, C. J. (1991) Chronic ethanol exposure increases levels of protein kinase C delta and epsilon and protein kinase C-mediated phosphorylation in cultured neural cells. *J Biol Chem* **266**, 23428-23432
194. Ponzoni, M., Lucarelli, E., Corrias, M. V., and Cornaglia-Ferraris, P. (1993) Protein kinase C isoenzymes in human neuroblasts. Involvement of PKC epsilon in cell differentiation. *FEBS Lett* **322**, 120-124
195. Fagerström, S., Pählman, S., Gestblom, C., and Nånberg, E. (1996) Protein kinase C-ε is implicated in neurite outgrowth in differentiating human neuroblastoma cells. *Cell Growth Differ* **7**, 775-785
196. Parrow, V., Fagerstrom, S., Meyerson, G., Nanberg, E., and Pahlman, S. (1995) Protein kinase C-alpha and -epsilon are enriched in growth cones of differentiating SH-SY5Y human neuroblastoma cells. *J Neurosci Res* **41**, 782-791

197. Brodie, C., Bogi, K., Acs, P., Lazarovici, P., Petrovics, G., Anderson, W. B., and Blumberg, P. M. (1999) Protein kinase C- $\epsilon$  plays a role in neurite outgrowth in response to epidermal growth factor and nerve growth factor in PC12 cells. *Cell Growth Differ* **10**, 183-191
198. Corbit, K. C., Foster, D. A., and Rosner, M. R. (1999) Protein kinase Cdelta mediates neurogenic but not mitogenic activation of mitogen-activated protein kinase in neuronal cells. *Mol Cell Biol* **19**, 4209-4218
199. Hundle, B., McMahon, T., Dadgar, J., and Messing, R. O. (1995) Overexpression of  $\epsilon$ -protein kinase C enhances nerve growth factor-induced phosphorylation of mitogen-activated protein kinases and neurite outgrowth. *J Biol Chem* **270**, 30134-30140
200. O'Driscoll, K. R., Teng, K. K., Fabbro, D., Greene, L. A., and Weinstein, I. B. (1995) Selective translocation of protein kinase C-delta in PC12 cells during nerve growth factor-induced neuritogenesis. *Mol Biol Cell* **6**, 449-458
201. Zeidman, R., Löfgren, B., Pählman, S., and Larsson, C. (1999) PKC $\epsilon$ , via its regulatory domain and independently of its catalytic domain, induces neurite-like processes in neuroblastoma cells. *J Cell Biol* **145**, 713-726
202. Rorth, P. (2003) Communication by touch: role of cellular extensions in complex animals. *Cell* **112**, 595-598
203. Ling, M., Trollér, U., Zeidman, R., Lundberg, C., and Larsson, C. (2004) Induction of neurites by the regulatory domains of PKC $\delta$  and  $\epsilon$  is counteracted by PKC catalytic activity and by the RhoA pathway. *Experimental cell research* **292**, 135-150
204. Troller, U., Raghunath, A., and Larsson, C. (2004) A possible role for p190RhoGAP in PKCepsilon-induced morphological effects. *Cell Signal* **16**, 245-252
205. Akita, Y. (2002) Protein kinase C-epsilon (PKC-epsilon): its unique structure and function. *J Biochem (Tokyo)* **132**, 847-852
206. Ohno, S., Akita, Y., Konno, Y., Imajoh, S., and Suzuki, K. (1988) A novel phorbol ester receptor/protein kinase, nPKC, distantly related to the protein kinase C family. *Cell* **53**, 731-741
207. Ono, Y., Fujii, T., Ogita, K., Kikkawa, U., Igarashi, K., and Nishizuka, Y. (1988) The structure, expression, and properties of additional members of the protein kinase C family. *J Biol Chem* **263**, 6927-6932
208. Trollér, U., and Larsson, C. (2006) Cdc42 is involved in PKCepsilon- and delta-induced neurite outgrowth and stress fibre dismantling. *Biochem Biophys Res Commun* **349**, 91-98
209. Ling, M., Trollér, U., Zeidman, R., Stensman, H., Schultz, A., and Larsson, C. (2005) Identification of conserved amino acids N-terminal of the PKC $\epsilon$ C1b domain crucial for protein kinase C $\epsilon$ -mediated induction of neurite outgrowth. *J Biol Chem* **280**, 17910-17919
210. Grimmer, M. R., and Weiss, W. A. (2006) Childhood tumors of the nervous system as disorders of normal development. *Curr Opin Pediatr* **18**, 634-638
211. Fung, M. M., Viveros, O. H., and O'Connor, D. T. (2008) Diseases of the adrenal medulla. *Acta physiologica (Oxford, England)* **192**, 325-335
212. Kline, N. E., and Sevier, N. (2003) Solid tumors in children. *Journal of pediatric nursing* **18**, 96-102
213. Matthay, K. K. (1995) Neuroblastoma: a clinical challenge and biologic puzzle. *CA: a cancer journal for clinicians* **45**, 179-192
214. Brodeur, G. M. (2003) Neuroblastoma: biological insights into a clinical enigma. *Nature reviews* **3**, 203-216
215. Kushner, B. H., Gilbert, F., and Helson, L. (1986) Familial neuroblastoma. Case reports, literature review, and etiologic considerations. *Cancer* **57**, 1887-1893
216. Maris, J. M., Kyemba, S. M., Rebbeck, T. R., White, P. S., Sulman, E. P., Jensen, S. J., Allen, C., Biegel, J. A., and Brodeur, G. M. (1997) Molecular genetic analysis of familial neuroblastoma. *Eur J Cancer* **33**, 1923-1928
217. Mosse, Y. P., Laudenslager, M., Longo, L., Cole, K. A., Wood, A., Attiyeh, E. F., Laquaglia, M. J., Sennett, R., Lynch, J. E., Perri, P., Laureys, G., Speleman, F., Kim, C., Hou, C., Hakonarson, H., Torkamani, A., Schork, N. J., Brodeur, G. M., Tonini, G. P., Rappaport, E., Devoto, M., and Maris, J. M. (2008) Identification of ALK as a major familial neuroblastoma predisposition gene. *Nature* **455**, 930-935
218. Vasudevan, S. A., Nuchtern, J. G., and Shohet, J. M. (2005) Gene profiling of high risk neuroblastoma.

219. Fredlund, E., Ringner, M., Maris, J. M., and Pahlman, S. (2008) High Myc pathway activity and low stage of neuronal differentiation associate with poor outcome in neuroblastoma. *Proc Natl Acad Sci U S A* **105**, 14094-14099
220. Hosoi, G., Hara, J., Okamura, T., Osugi, Y., Ishihara, S., Fukuzawa, M., Okada, A., Okada, S., and Tawa, A. (1994) Low frequency of the p53 gene mutations in neuroblastoma. *Cancer* **73**, 3087-3093
221. Grynfeld, A., Pahlman, S., and Axelson, H. (2000) Induced neuroblastoma cell differentiation, associated with transient HES-1 activity and reduced HASH-1 expression, is inhibited by Notch1. *Int J Cancer* **88**, 401-410
222. Savelyeva, L., Corvi, R., and Schwab, M. (1994) Translocation involving 1p and 17q is a recurrent genetic alteration of human neuroblastoma cells. *American journal of human genetics* **55**, 334-340
223. Brodeur, G. M., Pritchard, J., Berthold, F., Carlsen, N. L., Castel, V., Castelberry, R. P., De Bernardi, B., Evans, A. E., Favrot, M., Hedborg, F., and et al. (1993) Revisions of the international criteria for neuroblastoma diagnosis, staging, and response to treatment. *J Clin Oncol* **11**, 1466-1477
224. Nishihira, H., Toyoda, Y., Tanaka, Y., Ijiri, R., Aida, N., Takeuchi, M., Ohnuma, K., Kigasawa, H., Kato, K., and Nishi, T. (2000) Natural course of neuroblastoma detected by mass screening: a 5-year prospective study at a single institution. *J Clin Oncol* **18**, 3012-3017
225. Foley, J., Witte, D., Chiu, F. C., and Parysek, L. M. (1994) Expression of the neural intermediate filament proteins peripherin and neurofilament-66/alpha-internexin in neuroblastoma. *Lab Invest* **71**, 193-199
226. Portier, M. M., de Néchaud, B., and Gros, F. (1983) Peripherin, a new member of the intermediate filament protein family. *Dev Neurosci* **6**, 335-344
227. Parysek, L. M., and Goldman, R. D. (1988) Distribution of a novel 57 kDa intermediate filament (IF) protein in the nervous system. *J Neurosci* **8**, 555-563
228. Errante, L., Tang, D., Gardon, M., Sekerkova, G., Mugnaini, E., and Shaw, G. (1998) The intermediate filament protein peripherin is a marker for cerebellar climbing fibres. *Journal of neurocytology* **27**, 69-84
229. Chang, L., Shav-Tal, Y., Trcek, T., Singer, R. H., and Goldman, R. D. (2006) Assembling an intermediate filament network by dynamic cotranslation. *J Cell Biol* **172**, 747-758
230. Troy, C. M., Brown, K., Greene, L. A., and Shelanski, M. L. (1990) Ontogeny of the neuronal intermediate filament protein, peripherin, in the mouse embryo. *Neuroscience* **36**, 217-237
231. Landon, F., Wolff, A., and de Nechaud, B. (2000) Mouse peripherin isoforms. *Biology of the cell / under the auspices of the European Cell Biology Organization* **92**, 397-407
232. Robertson, J., Dorouchi, M. M., Nguyen, M. D., Durham, H. D., Strong, M. J., Shaw, G., Julien, J. P., and Mushynski, W. E. (2003) A neurotoxic peripherin splice variant in a mouse model of ALS. *J Cell Biol* **160**, 939-949
233. Xiao, S., Tjostheim, S., Sanelli, T., McLean, J. R., Horne, P., Fan, Y., Ravits, J., Strong, M. J., and Robertson, J. (2008) An aggregate-inducing peripherin isoform generated through intron retention is upregulated in amyotrophic lateral sclerosis and associated with disease pathology. *J Neurosci* **28**, 1833-1840
234. Chadan, S., Le Gall, J. Y., Di Giamberardino, L., and Filliatreau, G. (1994) Axonal transport of type III intermediate filament protein peripherin in intact and regenerating motor axons of the rat sciatic nerve. *J Neurosci Res* **39**, 127-139
235. Konishi, H., Namikawa, K., Shikata, K., Kobatake, Y., Tachibana, T., and Kiyama, H. (2007) Identification of peripherin as a akt substrate in neurons. *J Biol Chem* **282**, 23491-23499
236. Oblinger, M. M., Wong, J., and Parysek, L. M. (1989) Axotomy-induced changes in the expression of a type III neuronal intermediate filament gene. *J Neurosci* **9**, 3766-3775
237. Troy, C. M., Muma, N. A., Greene, L. A., Price, D. L., and Shelanski, M. L. (1990) Regulation of peripherin and neurofilament expression in regenerating rat motor neurons. *Brain Res* **529**, 232-238
238. Wong, N. K., He, B. P., and Strong, M. J. (2000) Characterization of neuronal intermediate filament protein expression in cervical spinal motor neurons in sporadic amyotrophic lateral sclerosis (ALS). *J Neuropathol Exp Neurol* **59**, 972-982
239. Escurat, M., Djabali, K., Gumpel, M., Gros, F., and Portier, M. M. (1990) Differential expression of two neuronal intermediate-filament proteins, peripherin and the low-molecular-mass neurofilament

- protein (NF-L), during the development of the rat. *J Neurosci* **10**, 764-784
240. Belecky-Adams, T., Holmes, M., Shan, Y., Tedesco, C. S., Mascari, C., Kaul, A., Wight, D. C., Morris, R. E., Sussman, M., Diamond, J., and Parysek, L. M. (2003) An intact intermediate filament network is required for collateral sprouting of small diameter nerve fibers. *J Neurosci* **23**, 9312-9319
  241. Gervasi, C., Stewart, C. B., and Szaro, B. G. (2000) *Xenopus laevis* peripherin (XIF3) is expressed in radial glia and proliferating neural epithelial cells as well as in neurons. *The Journal of comparative neurology* **423**, 512-531
  242. Aletta, J. M., Shelanski, M. L., and Greene, L. A. (1989) Phosphorylation of the peripherin 58-kDa neuronal intermediate filament protein. Regulation by nerve growth factor and other agents. *J Biol Chem* **264**, 4619-4627
  243. Helfand, B. T., Mendez, M. G., Pugh, J., Delsert, C., and Goldman, R. D. (2003) A role for intermediate filaments in determining and maintaining the shape of nerve cells. *Mol Biol Cell* **14**, 5069-5081
  244. Troy, C. M., Greene, L. A., and Shelanski, M. L. (1992) Neurite outgrowth in peripherin-depleted PC12 cells. *J Cell Biol* **117**, 1085-1092
  245. Larivière, R. C., Nguyen, M. D., Ribeiro-da-Silva, A., and Julien, J. P. (2002) Reduced number of myelinated sensory axons in peripherin null mice. *J Neurochem* **81**, 525-532
  246. Djabali, K., Zissopoulou, A., de Hoop, M. J., Georgatos, S. D., and Dotti, C. G. (1993) Peripherin expression in hippocampal neurons induced by muscle soluble factor(s). *J Cell Biol* **123**, 1197-1206
  247. Lecomte, M. J., Basseville, M., Landon, F., Karpov, V., and Fauquet, M. (1998) Transcriptional activation of the mouse peripherin gene by leukemia inhibitory factor: involvement of STAT proteins. *J Neurochem* **70**, 971-982
  248. Robertson, J., Beaulieu, J. M., Doroudchi, M. M., Durham, H. D., Julien, J. P., and Mushynski, W. E. (2001) Apoptotic death of neurons exhibiting peripherin aggregates is mediated by the proinflammatory cytokine tumor necrosis factor- $\alpha$ . *J Cell Biol* **155**, 217-226
  249. Sterneck, E., Kaplan, D. R., and Johnson, P. F. (1996) Interleukin-6 induces expression of peripherin and cooperates with Trk receptor signaling to promote neuronal differentiation in PC12 cells. *J Neurochem* **67**, 1365-1374
  250. Beaulieu, J. M., Kriz, J., and Julien, J. P. (2002) Induction of peripherin expression in subsets of brain neurons after lesion injury or cerebral ischemia. *Brain Res* **946**, 153-161
  251. Angelastro, J. M., Ho, C. L., Frappier, T., Liem, R. K., and Greene, L. A. (1998) Peripherin is tyrosine-phosphorylated at its carboxyl-terminal tyrosine. *J Neurochem* **70**, 540-549
  252. Escurat, M., Phamgia, H., Huc, C., Pouplard-Barthelaix, A., Boitard, C., Bach, J. F., Gros, F., and Portier, M. M. (1989) A new monoclonal antibody recognizing the amino-terminal consensus sequence of vertebrate intermediate filament proteins. *FEBS Lett* **253**, 157-162
  253. Huc, C., Escurat, M., Djabali, K., Derer, M., Landon, F., Gros, F., and Portier, M. M. (1989) Phosphorylation of peripherin, an intermediate filament protein, in mouse neuroblastoma NIE 115 cell line and in sympathetic neurons. *Biochem Biophys Res Commun* **160**, 772-779
  254. Eriksson, J. E., He, T., Trejo-Skalli, A. V., Harmala-Brasken, A. S., Hellman, J., Chou, Y. H., and Goldman, R. D. (2004) Specific in vivo phosphorylation sites determine the assembly dynamics of vimentin intermediate filaments. *J Cell Sci* **117**, 919-932
  255. Huang, C. K., Devanney, J. F., and Kennedy, S. P. (1988) Vimentin, a cytoskeletal substrate of protein kinase C. *Biochem Biophys Res Commun* **150**, 1006-1011
  256. Li, H., Guo, Y., Teng, J., Ding, M., Yu, A. C., and Chen, J. (2006) 14-3-3 $\gamma$  affects dynamics and integrity of glial filaments by binding to phosphorylated GFAP. *J Cell Sci* **119**, 4452-4461
  257. Corbo, M., and Hays, A. P. (1992) Peripherin and neurofilament protein coexist in spinal spheroids of motor neuron disease. *J Neuropathol Exp Neurol* **51**, 531-537
  258. Migheli, A., Pezzulo, T., Attanasio, A., and Schiffer, D. (1993) Peripherin immunoreactive structures in amyotrophic lateral sclerosis. *Lab Invest* **68**, 185-191
  259. Beaulieu, J. M., Jacomy, H., and Julien, J. P. (2000) Formation of intermediate filament protein aggregates with disparate effects in two transgenic mouse models lacking the neurofilament light subunit. *J Neurosci* **20**, 5321-5328
  260. Beaulieu, J. M., Nguyen, M. D., and Julien, J. P. (1999) Late onset of motor neurons in mice overexpressing wild-type peripherin. *J Cell Biol* **147**, 531-544
  261. Beaulieu, J. M., and Julien, J. P. (2003) Peripherin-mediated death of motor neurons rescued by



- overexpression of neurofilament NF-H proteins. *J Neurochem* **85**, 248-256
262. Magin, T. M., Reichelt, J., and Hatzfeld, M. (2004) Emerging functions: diseases and animal models reshape our view of the cytoskeleton. *Experimental cell research* **301**, 91-102
  263. Omary, M. B., Coulombe, P. A., and McLean, W. H. (2004) Intermediate filament proteins and their associated diseases. *The New England journal of medicine* **351**, 2087-2100
  264. Puertas, M. C., Carrillo, J., Pastor, X., Ampudia, R. M., Planas, R., Alba, A., Bruno, R., Pujol-Borrell, R., Estanyol, J. M., Vives-Pi, M., and Verdaguer, J. (2007) Peripherin is a relevant neuroendocrine autoantigen recognized by islet-infiltrating B lymphocytes. *J Immunol* **178**, 6533-6539
  265. Strong, M. J., Kesavapany, S., and Pant, H. C. (2005) The pathobiology of amyotrophic lateral sclerosis: a proteinopathy? *J Neuropathol Exp Neurol* **64**, 649-664
  266. Hand, C. K., and Rouleau, G. A. (2002) Familial amyotrophic lateral sclerosis. *Muscle & nerve* **25**, 135-159
  267. Shaw, P. J. (1999) Motor neurone disease. *BMJ (Clinical research ed)* **318**, 1118-1121
  268. Martin, L. J. (2001) Neuronal cell death in nervous system development, disease, and injury (Review). *Int J Mol Med* **7**, 455-478
  269. Camu, W., Khoris, J., Moulard, B., Salachas, F., Briolotti, V., Rouleau, G. A., and Meininger, V. (1999) Genetics of familial ALS and consequences for diagnosis. French ALS Research Group. *J Neurol Sci* **165 Suppl 1**, S21-26
  270. Kermer, P., Liman, J., Weishaupt, J. H., and Bahr, M. (2004) Neuronal apoptosis in neurodegenerative diseases: from basic research to clinical application. *Neurodegener Dis* **1**, 9-19
  271. Valdmanis, P. N., and Rouleau, G. A. (2008) Genetics of familial amyotrophic lateral sclerosis. *Neurology* **70**, 144-152
  272. He, C. Z., and Hays, A. P. (2004) Expression of peripherin in ubiquitinated inclusions of amyotrophic lateral sclerosis. *J Neurol Sci* **217**, 47-54
  273. Xiao, S., McLean, J., and Robertson, J. (2006) Neuronal intermediate filaments and ALS: A new look at an old question. *Biochim Biophys Acta* **1762**, 1001-1012
  274. Leigh, P. N., Whitwell, H., Garofalo, O., Buller, J., Swash, M., Martin, J. E., Gallo, J. M., Weller, R. O., and Anderton, B. H. (1991) Ubiquitin-immunoreactive intraneuronal inclusions in amyotrophic lateral sclerosis. Morphology, distribution, and specificity. *Brain* **114 ( Pt 2)**, 775-788
  275. Lowe, J., Lennox, G., Jefferson, D., Morrell, K., McQuire, D., Gray, T., Landon, M., Doherty, F. J., and Mayer, R. J. (1988) A filamentous inclusion body within anterior horn neurones in motor neurone disease defined by immunocytochemical localisation of ubiquitin. *Neurosci Lett* **94**, 203-210
  276. Zatloukal, K., Stumptner, C., Fuchsichler, A., Janig, E., and Denk, H. (2004) Intermediate filament protein inclusions. *Methods in cell biology* **78**, 205-228
  277. Julien, J. P., and Beaulieu, J. M. (2000) Cytoskeletal abnormalities in amyotrophic lateral sclerosis: beneficial or detrimental effects? *J Neurol Sci* **180**, 7-14
  278. Gros-Louis, F., Gaspar, C., and Rouleau, G. A. (2006) Genetics of familial and sporadic amyotrophic lateral sclerosis. *Biochim Biophys Acta* **1762**, 956-972
  279. Bergeron, C., Petrunka, C., and Weyer, L. (1996) Copper/zinc superoxide dismutase expression in the human central nervous system. Correlation with selective neuronal vulnerability. *Am J Pathol* **148**, 273-279
  280. Deng, H. X., Hentati, A., Tainer, J. A., Iqbal, Z., Cayabyab, A., Hung, W. Y., Getzoff, E. D., Hu, P., Herzfeldt, B., Roos, R. P., and et al. (1993) Amyotrophic lateral sclerosis and structural defects in Cu,Zn superoxide dismutase. *Science* **261**, 1047-1051
  281. Rosen, D. R., Siddique, T., Patterson, D., Figlewicz, D. A., Sapp, P., Hentati, A., Donaldson, D., Goto, J., O'Regan, J. P., Deng, H. X., and et al. (1993) Mutations in Cu/Zn superoxide dismutase gene are associated with familial amyotrophic lateral sclerosis. *Nature* **362**, 59-62
  282. Jackson, M., Al-Chalabi, A., Enayat, Z. E., Chioza, B., Leigh, P. N., and Morrison, K. E. (1997) Copper/zinc superoxide dismutase 1 and sporadic amyotrophic lateral sclerosis: analysis of 155 cases and identification of a novel insertion mutation. *Annals of neurology* **42**, 803-807
  283. Cookson, M. R., and Shaw, P. J. (1999) Oxidative stress and motor neurone disease. *Brain Pathol* **9**, 165-186
  284. Shaw, B. F., and Valentine, J. S. (2007) How do ALS-associated mutations in superoxide dismutase 1 promote aggregation of the protein? *Trends Biochem Sci* **32**, 78-85

285. Strom, A. L., Shi, P., Zhang, F., Gal, J., Kilty, R., Hayward, L. J., and Zhu, H. (2008) Interaction of amyotrophic lateral sclerosis (ALS)-related mutant copper-zinc superoxide dismutase with the dynein-dynactin complex contributes to inclusion formation. *J Biol Chem* **283**, 22795-22805
286. Pasinelli, P., Belford, M. E., Lennon, N., Bacskai, B. J., Hyman, B. T., Trotti, D., and Brown, R. H., Jr. (2004) Amyotrophic lateral sclerosis-associated SOD1 mutant proteins bind and aggregate with Bcl-2 in spinal cord mitochondria. *Neuron* **43**, 19-30
287. Urushitani, M., Kurisu, J., Tsukita, K., and Takahashi, R. (2002) Proteasomal inhibition by misfolded mutant superoxide dismutase 1 induces selective motor neuron death in familial amyotrophic lateral sclerosis. *J Neurochem* **83**, 1030-1042
288. Damiano, M., Starkov, A. A., Petri, S., Kipiani, K., Kiaei, M., Mattiazzi, M., Flint Beal, M., and Manfredi, G. (2006) Neural mitochondrial Ca<sup>2+</sup> capacity impairment precedes the onset of motor symptoms in G93A Cu/Zn-superoxide dismutase mutant mice. *J Neurochem* **96**, 1349-1361
289. Hervias, L., Beal, M. F., and Manfredi, G. (2006) Mitochondrial dysfunction and amyotrophic lateral sclerosis. *Muscle & nerve* **33**, 598-608
290. Heath, P. R., and Shaw, P. J. (2002) Update on the glutamatergic neurotransmitter system and the role of excitotoxicity in amyotrophic lateral sclerosis. *Muscle & nerve* **26**, 438-458
291. Banci, L., Bertini, I., Boca, M., Giroto, S., Martinelli, M., Valentine, J. S., and Vieru, M. (2008) SOD1 and amyotrophic lateral sclerosis: mutations and oligomerization. *PLoS ONE* **3**, e1677
292. Elliott, J. L. (1999) Experimental models of amyotrophic lateral sclerosis. *Neurobiology of disease* **6**, 310-320
293. Gurney, M. E., Pu, H., Chiu, A. Y., Dal Canto, M. C., Polchow, C. Y., Alexander, D. D., Caliendo, J., Hentati, A., Kwon, Y. W., Deng, H. X., and et al. (1994) Motor neuron degeneration in mice that express a human Cu,Zn superoxide dismutase mutation. *Science* **264**, 1772-1775
294. Reaume, A. G., Elliott, J. L., Hoffman, E. K., Kowall, N. W., Ferrante, R. J., Siwek, D. F., Wilcox, H. M., Flood, D. G., Beal, M. F., Brown, R. H., Jr., Scott, R. W., and Snider, W. D. (1996) Motor neurons in Cu/Zn superoxide dismutase-deficient mice develop normally but exhibit enhanced cell death after axonal injury. *Nature genetics* **13**, 43-47
295. Wang, J., Xu, G., and Borchelt, D. R. (2002) High molecular weight complexes of mutant superoxide dismutase 1: age-dependent and tissue-specific accumulation. *Neurobiology of disease* **9**, 139-148
296. Julien, J. P. (2001) Amyotrophic lateral sclerosis. unfolding the toxicity of the misfolded. *Cell* **104**, 581-591
297. Majoor-Krakauer, D., Ottman, R., Johnson, W. G., and Rowland, L. P. (1994) Familial aggregation of amyotrophic lateral sclerosis, dementia, and Parkinson's disease: evidence of shared genetic susceptibility. *Neurology* **44**, 1872-1877
298. Guégan, C., and Przedborski, S. (2003) Programmed cell death in amyotrophic lateral sclerosis. *The Journal of clinical investigation* **111**, 153-161
299. Sathasivam, S., and Shaw, P. J. (2005) Apoptosis in amyotrophic lateral sclerosis--what is the evidence? *Lancet neurology* **4**, 500-509
300. Martin, L. J. (1999) Neuronal death in amyotrophic lateral sclerosis is apoptosis: possible contribution of a programmed cell death mechanism. *J Neuropathol Exp Neurol* **58**, 459-471
301. Reed, J. C. (2000) Mechanisms of apoptosis. *Am J Pathol* **157**, 1415-1430
302. Li, M., Ona, V. O., Guegan, C., Chen, M., Jackson-Lewis, V., Andrews, L. J., Olszewski, A. J., Stieg, P. E., Lee, J. P., Przedborski, S., and Friedlander, R. M. (2000) Functional role of caspase-1 and caspase-3 in an ALS transgenic mouse model. *Science* **288**, 335-339
303. Pasinelli, P., Borchelt, D. R., Houseweart, M. K., Cleveland, D. W., and Brown, R. H., Jr. (1998) Caspase-1 is activated in neural cells and tissue with amyotrophic lateral sclerosis-associated mutations in copper-zinc superoxide dismutase. *Proc Natl Acad Sci U S A* **95**, 15763-15768
304. Sathasivam, S., Ince, P. G., and Shaw, P. J. (2001) Apoptosis in amyotrophic lateral sclerosis: a review of the evidence. *Neuropathol Appl Neurobiol* **27**, 257-274
305. Mattson, M. P. (2000) Apoptosis in neurodegenerative disorders. *Nat Rev Mol Cell Biol* **1**, 120-129
306. Ekegren, T., Grundstrom, E., Lindholm, D., and Aquilonius, S. M. (1999) Upregulation of Bax protein and increased DNA degradation in ALS spinal cord motor neurons. *Acta neurologica Scandinavica* **100**, 317-321
307. Yoshizawa, Y., Yamada, T., Asanuma, K., and Asahi, T. (1994) Apoptosis related antigen, Le(Y)



- and nick-end labeling are positive in spinal motor neurons in amyotrophic lateral sclerosis. *Acta neuropathologica* **88**, 207-211
308. Mu, X., He, J., Anderson, D. W., Trojanowski, J. Q., and Springer, J. E. (1996) Altered expression of bcl-2 and bax mRNA in amyotrophic lateral sclerosis spinal cord motor neurons. *Annals of neurology* **40**, 379-386
  309. Embacher, N., Kaufmann, W. A., Beer, R., Maier, H., Jellinger, K. A., Poewe, W., and Ransmayr, G. (2001) Apoptosis signals in sporadic amyotrophic lateral sclerosis: an immunocytochemical study. *Acta Neuropathol (Berl)* **102**, 426-434
  310. He, B. P., and Strong, M. J. (2000) Motor neuronal death in sporadic amyotrophic lateral sclerosis (ALS) is not apoptotic. A comparative study of ALS and chronic aluminium chloride neurotoxicity in New Zealand white rabbits. *Neuropathol Appl Neurobiol* **26**, 150-160
  311. Oppenheim, R. W., Prevette, D., Yin, Q. W., Collins, F., and MacDonald, J. (1991) Control of embryonic motoneuron survival in vivo by ciliary neurotrophic factor. *Science* **251**, 1616-1618
  312. Rothstein, J. D., Tsai, G., Kuncel, R. W., Clawson, L., Cornblath, D. R., Drachman, D. B., Pestronk, A., Stauch, B. L., and Coyle, J. T. (1990) Abnormal excitatory amino acid metabolism in amyotrophic lateral sclerosis. *Annals of neurology* **28**, 18-25
  313. Spreux-Varoquaux, O., Bensimon, G., Lacomblez, L., Salachas, F., Pradat, P. F., Le Forestier, N., Marouan, A., Dib, M., and Meininger, V. (2002) Glutamate levels in cerebrospinal fluid in amyotrophic lateral sclerosis: a reappraisal using a new HPLC method with coulometric detection in a large cohort of patients. *J Neurol Sci* **193**, 73-78
  314. Kamel, F., Umbach, D. M., Munsat, T. L., Shefner, J. M., and Sandler, D. P. (1999) Association of cigarette smoking with amyotrophic lateral sclerosis. *Neuroepidemiology* **18**, 194-202
  315. Nelson, L. M., McGuire, V., Longstreth, W. T., Jr., and Matkin, C. (2000) Population-based case-control study of amyotrophic lateral sclerosis in western Washington State. I. Cigarette smoking and alcohol consumption. *American journal of epidemiology* **151**, 156-163
  316. de la Monte, S. M., Sohn, Y. K., Ganju, N., and Wands, J. R. (1998) P53- and CD95-associated apoptosis in neurodegenerative diseases. *Lab Invest* **78**, 401-411
  317. Martin, L. J. (2000) p53 is abnormally elevated and active in the CNS of patients with amyotrophic lateral sclerosis. *Neurobiology of disease* **7**, 613-622
  318. Kuntz, C. t., Kinoshita, Y., Beal, M. F., Donehower, L. A., and Morrison, R. S. (2000) Absence of p53: no effect in a transgenic mouse model of familial amyotrophic lateral sclerosis. *Experimental neurology* **165**, 184-190
  319. McLean, J., Xiao, S., Miyazaki, K., and Robertson, J. (2008) A novel peripherin isoform generated by alternative translation is required for normal filament network formation. *J Neurochem*
  320. Gros-Louis, F., Larivière, R., Gowing, G., Laurent, S., Camu, W., Bouchard, J. P., Meininger, V., Rouleau, G. A., and Julien, J. P. (2004) A frameshift deletion in peripherin gene associated with amyotrophic lateral sclerosis. *J Biol Chem* **279**, 45951-45956
  321. Leung, C. L., He, C. Z., Kaufmann, P., Chin, S. S., Naini, A., Liem, R. K., Mitsumoto, H., and Hays, A. P. (2004) A pathogenic peripherin gene mutation in a patient with amyotrophic lateral sclerosis. *Brain Pathol* **14**, 290-296
  322. Sekizawa, T., Openshaw, H., Ohbo, K., Sugamura, K., Itoyama, Y., and Niland, J. C. (1998) Cerebrospinal fluid interleukin 6 in amyotrophic lateral sclerosis: immunological parameter and comparison with inflammatory and non-inflammatory central nervous system diseases. *J Neurol Sci* **154**, 194-199
  323. Blobel, G. (1973) A protein of molecular weight 78,000 bound to the polyadenylate region of eukaryotic messenger RNAs. *Proc Natl Acad Sci U S A* **70**, 924-928
  324. Deo, R. C., Bonanno, J. B., Sonenberg, N., and Burley, S. K. (1999) Recognition of polyadenylate RNA by the poly(A)-binding protein. *Cell* **98**, 835-845
  325. Mangus, D. A., Evans, M. C., and Jacobson, A. (2003) Poly(A)-binding proteins: multifunctional scaffolds for the post-transcriptional control of gene expression. *Genome Biol* **4**, 223
  326. Baer, B. W., and Kornberg, R. D. (1980) Repeating structure of cytoplasmic poly(A)-ribonucleoprotein. *Proc Natl Acad Sci U S A* **77**, 1890-1892
  327. Gorgoni, B., and Gray, N. K. (2004) The roles of cytoplasmic poly(A)-binding proteins in regulating gene expression: a developmental perspective. *Briefings in functional genomics & proteomics* **3**, 125-141

328. Wilkie, G. S., Dickson, K. S., and Gray, N. K. (2003) Regulation of mRNA translation by 5'- and 3'-UTR-binding factors. *Trends Biochem Sci* **28**, 182-188
329. Craig, A. W., Haghighat, A., Yu, A. T., and Sonenberg, N. (1998) Interaction of polyadenylate-binding protein with the eIF4G homologue PAIP enhances translation. *Nature* **392**, 520-523
330. Tourriere, H., Chebli, K., and Tazi, J. (2002) mRNA degradation machines in eukaryotic cells. *Biochimie* **84**, 821-837
331. Parker, F., Maurier, F., Delumeau, I., Duchesne, M., Faucher, D., Debussche, L., Dugue, A., Schweighoffer, F., and Tocque, B. (1996) A Ras-GTPase-activating protein SH3-domain-binding protein. *Mol Cell Biol* **16**, 2561-2569
332. Pazman, C., Mayes, C. A., Fanto, M., Haynes, S. R., and Mlodzik, M. (2000) Rasputin, the Drosophila homologue of the RasGAP SH3 binding protein, functions in ras- and Rho-mediated signaling. *Development (Cambridge, England)* **127**, 1715-1725
333. Guitard, E., Parker, F., Millon, R., Abecassis, J., and Tocque, B. (2001) G3BP is overexpressed in human tumors and promotes S phase entry. *Cancer Lett* **162**, 213-221
334. Tocque, B., Delumeau, I., Parker, F., Maurier, F., Multon, M. C., and Schweighoffer, F. (1997) Ras-GTPase activating protein (GAP): a putative effector for Ras. *Cell Signal* **9**, 153-158
335. Lypowy, J., Chen, I. Y., and Abdellatif, M. (2005) An alliance between Ras GTPase-activating protein, filamin C, and Ras GTPase-activating protein SH3 domain-binding protein regulates myocyte growth. *J Biol Chem* **280**, 25717-25728
336. Zekri, L., Chebli, K., Tourriere, H., Nielsen, F. C., Hansen, T. V., Rami, A., and Tazi, J. (2005) Control of fetal growth and neonatal survival by the RasGAP-associated endoribonuclease G3BP. *Mol Cell Biol* **25**, 8703-8716
337. Kennedy, D., French, J., Guitard, E., Ru, K., Tocque, B., and Mattick, J. (2001) Characterization of G3BPs: tissue specific expression, chromosomal localisation and rasGAP(120) binding studies. *J Cell Biochem* **84**, 173-187
338. French, J., Stirling, R., Walsh, M., and Kennedy, H. D. (2002) The expression of Ras-GTPase activating protein SH3 domain-binding proteins, G3BPs, in human breast cancers. *Histochem J* **34**, 223-231
339. Irvine, K., Stirling, R., Hume, D., and Kennedy, D. (2004) Rasputin, more promiscuous than ever: a review of G3BP. *The International journal of developmental biology* **48**, 1065-1077
340. Prigent, M., Barlat, I., Langen, H., and Dargemont, C. (2000) IkappaBalpha /NF-kappa B complexes are retained in the cytoplasm through interaction with a novel partner, RasGAP SH3-binding protein 2. *J Biol Chem* **275**, 36441-36449
341. Kim, M. M., Wiederschain, D., Kennedy, D., Hansen, E., and Yuan, Z. M. (2007) Modulation of p53 and MDM2 activity by novel interaction with Ras-GAP binding proteins (G3BP). *Oncogene*
342. Barnes, C. J., Li, F., Mandal, M., Yang, Z., Sahin, A. A., and Kumar, R. (2002) Heregulin induces expression, ATPase activity, and nuclear localization of G3BP, a Ras signaling component, in human breast tumors. *Cancer Res* **62**, 1251-1255
343. Gallouzi, I. E., Parker, F., Chebli, K., Maurier, F., Labourier, E., Barlat, I., Capony, J. P., Tocque, B., and Tazi, J. (1998) A novel phosphorylation-dependent RNase activity of GAP-SH3 binding protein: a potential link between signal transduction and RNA stability. *Mol Cell Biol* **18**, 3956-3965
344. Tourriere, H., Gallouzi, I. E., Chebli, K., Capony, J. P., Mouaikel, J., van der Geer, P., and Tazi, J. (2001) RasGAP-associated endoribonuclease G3BP: selective RNA degradation and phosphorylation-dependent localization. *Mol Cell Biol* **21**, 7747-7760
345. Soncini, C., Berdo, I., and Draetta, G. (2001) Ras-GAP SH3 domain binding protein (G3BP) is a modulator of USP10, a novel human ubiquitin specific protease. *Oncogene* **20**, 3869-3879
346. Zhang, H. Z., Liu, J. G., Wei, Y. P., Wu, C., Cao, Y. K., and Wang, M. (2007) Expression of G3BP and RhoC in esophageal squamous carcinoma and their effect on prognosis. *World J Gastroenterol* **13**, 4126-4130
347. Kedersha, N., Stoecklin, G., Ayodele, M., Yacono, P., Lykke-Andersen, J., Fritzler, M. J., Scheuner, D., Kaufman, R. J., Golan, D. E., and Anderson, P. (2005) Stress granules and processing bodies are dynamically linked sites of mRNP remodeling. *J Cell Biol* **169**, 871-884
348. Tourriere, H., Chebli, K., Zekri, L., Courselaud, B., Blanchard, J. M., Bertrand, E., and Tazi, J. (2003) The RasGAP-associated endoribonuclease G3BP assembles stress granules. *J Cell Biol* **160**, 823-831
349. Nielsen, F. C., Nielsen, J., and Christiansen, J. (2001) A family of IGF-II mRNA binding proteins

- (IMP) involved in RNA trafficking. *Scandinavian journal of clinical and laboratory investigation* **234**, 93-99
350. Nielsen, J., Christiansen, J., Lykke-Andersen, J., Johnsen, A. H., Wewer, U. M., and Nielsen, F. C. (1999) A family of insulin-like growth factor II mRNA-binding proteins represses translation in late development. *Mol Cell Biol* **19**, 1262-1270
351. Jonson, L., Vikesaa, J., Krogh, A., Nielsen, L. K., Hansen, T., Borup, R., Johnsen, A. H., Christiansen, J., and Nielsen, F. C. (2007) Molecular composition of IMP1 ribonucleoprotein granules. *Mol Cell Proteomics* **6**, 798-811
352. Nielsen, F. C., Nielsen, J., Kristensen, M. A., Koch, G., and Christiansen, J. (2002) Cytoplasmic trafficking of IGF-II mRNA-binding protein by conserved KH domains. *J Cell Sci* **115**, 2087-2097
353. Ioannidis, P., Mahaira, L. G., Perez, S. A., Gritzapis, A. D., Sotiropoulou, P. A., Kavalakis, G. J., Antsaklis, A. I., Baxevanis, C. N., and Papamichail, M. (2005) CRD-BP/IMP1 expression characterizes cord blood CD34+ stem cells and affects c-myc and IGF-II expression in MCF-7 cancer cells. *J Biol Chem* **280**, 20086-20093
354. Nielsen, J., Adolph, S. K., Rajpert-De Meyts, E., Lykke-Andersen, J., Koch, G., Christiansen, J., and Nielsen, F. C. (2003) Nuclear transit of human zipcode-binding protein IMP1. *Biochem J* **376**, 383-391
355. Mueller-Pillasch, F., Lacher, U., Wallrapp, C., Micha, A., Zimmerhackl, F., Hameister, H., Varga, G., Friess, H., Buchler, M., Beger, H. G., Vila, M. R., Adler, G., and Gress, T. M. (1997) Cloning of a gene highly overexpressed in cancer coding for a novel KH-domain containing protein. *Oncogene* **14**, 2729-2733
356. Ioannidis, P., Trangas, T., Dimitriadis, E., Samiotaki, M., Kyriazoglou, I., Tsiapalis, C. M., Kittas, C., Agnantis, N., Nielsen, F. C., Nielsen, J., Christiansen, J., and Pandis, N. (2001) C-MYC and IGF-II mRNA-binding protein (CRD-BP/IMP-1) in benign and malignant mesenchymal tumors. *Int J Cancer* **94**, 480-484
357. Gu, L., Shigemasa, K., and Ohama, K. (2004) Increased expression of IGF II mRNA-binding protein I mRNA is associated with an advanced clinical stage and poor prognosis in patients with ovarian cancer. *International journal of oncology* **24**, 671-678
358. Ioannidis, P., Kottaridi, C., Dimitriadis, E., Courtis, N., Mahaira, L., Talieri, M., Giannopoulos, A., Iliadis, K., Papaioannou, D., Nasioulas, G., and Trangas, T. (2004) Expression of the RNA-binding protein CRD-BP in brain and non-small cell lung tumors. *Cancer Lett* **209**, 245-250
359. Stohr, N., Lederer, M., Reinke, C., Meyer, S., Hatzfeld, M., Singer, R. H., and Huttelmaier, S. (2006) ZBP1 regulates mRNA stability during cellular stress. *J Cell Biol* **175**, 527-534
360. Anderson, P., and Kedersha, N. (2006) RNA granules. *J Cell Biol* **172**, 803-808
361. Eulalio, A., Behm-Ansmant, I., and Izaurralde, E. (2007) P bodies: at the crossroads of post-transcriptional pathways. *Nat Rev Mol Cell Biol* **8**, 9-22
362. Kiebler, M. A., and Bassell, G. J. (2006) Neuronal RNA granules: movers and makers. *Neuron* **51**, 685-690
363. Steward, O., and Worley, P. (2001) Localization of mRNAs at synaptic sites on dendrites. *Results and problems in cell differentiation* **34**, 1-26
364. Kedersha, N., and Anderson, P. (2007) Mammalian stress granules and processing bodies. *Methods in enzymology* **431**, 61-81
365. Teixeira, D., Sheth, U., Valencia-Sanchez, M. A., Brengues, M., and Parker, R. (2005) Processing bodies require RNA for assembly and contain nontranslating mRNAs. *RNA (New York, N.Y)* **11**, 371-382
366. van Dijk, E., Cougot, N., Meyer, S., Babajko, S., Wahle, E., and Seraphin, B. (2002) Human Dcp2: a catalytically active mRNA decapping enzyme located in specific cytoplasmic structures. *Embo J* **21**, 6915-6924
367. Chang, Y. F., Imam, J. S., and Wilkinson, M. F. (2007) The nonsense-mediated decay RNA surveillance pathway. *Annual review of biochemistry* **76**, 51-74
368. Brengues, M., Teixeira, D., and Parker, R. (2005) Movement of eukaryotic mRNAs between polysomes and cytoplasmic processing bodies. *Science* **310**, 486-489
369. Yamasaki, S., and Anderson, P. (2008) Reprogramming mRNA translation during stress. *Current opinion in cell biology*

370. Ivanov, P. A., and Nadezhkina, E. S. (2006) [Stress granules: RNP-containing cytoplasmic bodies springing up under stress. The structure and mechanism of organization]. *Molekuliarnaia biologii* **40**, 937-944
371. Kedersha, N. L., Gupta, M., Li, W., Miller, I., and Anderson, P. (1999) RNA-binding proteins TIA-1 and TIAR link the phosphorylation of eIF-2 alpha to the assembly of mammalian stress granules. *J Cell Biol* **147**, 1431-1442
372. Kimball, S. R., Horetsky, R. L., Ron, D., Jefferson, L. S., and Harding, H. P. (2003) Mammalian stress granules represent sites of accumulation of stalled translation initiation complexes. *Am J Physiol Cell Physiol* **284**, C273-284
373. Anderson, P., and Kedersha, N. (2002) Stressful initiations. *J Cell Sci* **115**, 3227-3234
374. Cotto, J., Fox, S., and Morimoto, R. (1997) HSF1 granules: a novel stress-induced nuclear compartment of human cells. *J Cell Sci* **110** ( Pt 23), 2925-2934
375. Garrido, C., Gurbuxani, S., Ravagnan, L., and Kroemer, G. (2001) Heat shock proteins: endogenous modulators of apoptotic cell death. *Biochem Biophys Res Commun* **286**, 433-442
376. Santoro, M. G. (2000) Heat shock factors and the control of the stress response. *Biochemical pharmacology* **59**, 55-63
377. Kedersha, N., and Anderson, P. (2002) Stress granules: sites of mRNA triage that regulate mRNA stability and translatability. *Biochem Soc Trans* **30**, 963-969
378. Parker, R., and Sheth, U. (2007) P bodies and the control of mRNA translation and degradation. *Mol Cell* **25**, 635-646
379. Arrigo, A. P., Suhan, J. P., and Welch, W. J. (1988) Dynamic changes in the structure and intracellular locale of the mammalian low-molecular-weight heat shock protein. *Mol Cell Biol* **8**, 5059-5071
380. Nover, L., Scharf, K. D., and Neumann, D. (1983) Formation of cytoplasmic heat shock granules in tomato cell cultures and leaves. *Mol Cell Biol* **3**, 1648-1655
381. Collier, N. C., Heuser, J., Levy, M. A., and Schlesinger, M. J. (1988) Ultrastructural and biochemical analysis of the stress granule in chicken embryo fibroblasts. *J Cell Biol* **106**, 1131-1139
382. Harding, H. P., Zhang, Y., and Ron, D. (1999) Protein translation and folding are coupled by an endoplasmic-reticulum-resident kinase. *Nature* **397**, 271-274
383. Jiang, H. Y., and Wek, R. C. (2005) GCN2 phosphorylation of eIF2alpha activates NF-kappaB in response to UV irradiation. *Biochem J* **385**, 371-380
384. Lu, L., Han, A. P., and Chen, J. J. (2001) Translation initiation control by heme-regulated eukaryotic initiation factor 2alpha kinase in erythroid cells under cytoplasmic stresses. *Mol Cell Biol* **21**, 7971-7980
385. Wu, S., Hu, Y., Wang, J. L., Chatterjee, M., Shi, Y., and Kaufman, R. J. (2002) Ultraviolet light inhibits translation through activation of the unfolded protein response kinase PERK in the lumen of the endoplasmic reticulum. *J Biol Chem* **277**, 18077-18083
386. Anderson, P., and Kedersha, N. (2002) Visibly stressed: the role of eIF2, TIA-1, and stress granules in protein translation. *Cell stress & chaperones* **7**, 213-221
387. Kedersha, N., Chen, S., Gilks, N., Li, W., Miller, I. J., Stahl, J., and Anderson, P. (2002) Evidence that ternary complex (eIF2-GTP-tRNA(i)(Met))-deficient preinitiation complexes are core constituents of mammalian stress granules. *Mol Biol Cell* **13**, 195-210
388. Kedersha, N., Cho, M. R., Li, W., Yacono, P. W., Chen, S., Gilks, N., Golan, D. E., and Anderson, P. (2000) Dynamic shuttling of TIA-1 accompanies the recruitment of mRNA to mammalian stress granules. *J Cell Biol* **151**, 1257-1268
389. Wilczynska, A., Aigueperse, C., Kress, M., Dautry, F., and Weil, D. (2005) The translational regulator CPEB1 provides a link between dcp1 bodies and stress granules. *J Cell Sci* **118**, 981-992
390. Hua, Y., and Zhou, J. (2004) Survival motor neuron protein facilitates assembly of stress granules. *FEBS Lett* **572**, 69-74
391. Gilks, N., Kedersha, N., Ayodele, M., Shen, L., Stoecklin, G., Dember, L. M., and Anderson, P. (2004) Stress granule assembly is mediated by prion-like aggregation of TIA-1. *Mol Biol Cell* **15**, 5383-5398
392. Mazroui, R., Huot, M. E., Tremblay, S., Filion, C., Labelle, Y., and Khandjian, E. W. (2002) Trapping of messenger RNA by Fragile X Mental Retardation protein into cytoplasmic granules induces translation repression. *Human molecular genetics* **11**, 3007-3017

393. Solomon, S., Xu, Y., Wang, B., David, M. D., Schubert, P., Kennedy, D., and Schrader, J. W. (2007) Distinct structural features of caprin-1 mediate its interaction with G3BP-1 and its induction of phosphorylation of eukaryotic translation initiation factor 2alpha, entry to cytoplasmic stress granules, and selective interaction with a subset of mRNAs. *Mol Cell Biol* **27**, 2324-2342
394. Sivan, G., Kedersha, N., and Elroy-Stein, O. (2007) Ribosomal slowdown mediates translational arrest during cellular division. *Mol Cell Biol* **27**, 6639-6646
395. Guil, S., Long, J. C., and Caceres, J. F. (2006) hnRNP A1 relocalization to the stress granules reflects a role in the stress response. *Mol Cell Biol* **26**, 5744-5758
396. Han, D. C., Shen, T. L., and Guan, J. L. (2001) The Grb7 family proteins: structure, interactions with other signaling molecules and potential cellular functions. *Oncogene* **20**, 6315-6321
397. Shen, T. L., and Guan, J. L. (2004) Grb7 in intracellular signaling and its role in cell regulation. *Front Biosci* **9**, 192-200
398. Tsai, N. P., Ho, P. C., and Wei, L. N. (2008) Regulation of stress granule dynamics by Grb7 and FAK signalling pathway. *Embo J* **27**, 715-726
399. Cande, C., Vahsen, N., Metivier, D., Tourriere, H., Chebli, K., Garrido, C., Tazi, J., and Kroemer, G. (2004) Regulation of cytoplasmic stress granules by apoptosis-inducing factor. *J Cell Sci* **117**, 4461-4468
400. Kim, W. J., Back, S. H., Kim, V., Ryu, I., and Jang, S. K. (2005) Sequestration of TRAF2 into stress granules interrupts tumor necrosis factor signaling under stress conditions. *Mol Cell Biol* **25**, 2450-2462
401. Ivanov, P. A., Chudinova, E. M., and Nadezhdina, E. S. (2003) Disruption of microtubules inhibits cytoplasmic ribonucleoprotein stress granule formation. *Experimental cell research* **290**, 227-233
402. Hilliker, A., and Parker, R. (2008) Stressed out? Make some modifications! *Nat Cell Biol* **10**, 1129-1130
403. Ohn, T., Kedersha, N., Hickman, T., Tisdale, S., and Anderson, P. (2008) A functional RNAi screen links O-GlcNAc modification of ribosomal proteins to stress granule and processing body assembly. *Nat Cell Biol* **10**, 1224-1231
404. Kwon, S., Zhang, Y., and Matthias, P. (2007) The deacetylase HDAC6 is a novel critical component of stress granules involved in the stress response. *Genes Dev* **21**, 3381-3394
405. Irie, K., Nakagawa, Y., and Ohigashi, H. (2005) Toward the development of new medicinal leads with selectivity for protein kinase C isozymes. *Chemical record (New York, N.Y)* **5**, 185-195
406. Shindo, M., Irie, K., Nakahara, A., Ohigashi, H., Konishi, H., Kikkawa, U., Fukuda, H., and Wender, P. A. (2001) Toward the identification of selective modulators of protein kinase C (PKC) isozymes: establishment of a binding assay for PKC isozymes using synthetic C1 peptide receptors and identification of the critical residues involved in the phorbol ester binding. *Bioorg Med Chem* **9**, 2073-2081
407. Wang, H., and Kazanietz, M. G. (2002) Chimaerins, novel non-protein kinase C phorbol ester receptors, associate with Tmp21-I (p23): evidence for a novel anchoring mechanism involving the chimaerin C1 domain. *J Biol Chem* **277**, 4541-4550
408. Mattson, M. P. (1991) Evidence for the involvement of protein kinase C in neurodegenerative changes in cultured human cortical neurons. *Experimental neurology* **112**, 95-103
409. Ivaska, J., Vuoriluoto, K., Huovinen, T., Izawa, I., Inagaki, M., and Parker, P. J. (2005) PKCε-mediated phosphorylation of vimentin controls integrin recycling and motility. *Embo J* **24**, 3834-3845
410. Robertson, J., Kriz, J., Nguyen, M. D., and Julien, J. P. (2002) Pathways to motor neuron degeneration in transgenic mouse models. *Biochimie* **84**, 1151-1160
411. Cui, C., Stambrook, P. J., and Parysek, L. M. (1995) Peripherin assembles into homopolymers in SW13 cells. *J Cell Sci* **108 ( Pt 10)**, 3279-3284
412. Ho, C. L., Chien, C. L., Brown, K., and Liem, R. K. (1998) Ultrastructural studies of carboxyl-terminal truncation mutants of the neuronal intermediate filament protein peripherin. *J Neurochem* **70**, 1916-1924
413. Raats, J. M., Henderik, J. B., Verdijk, M., van Oort, F. L., Gerards, W. L., Ramaekers, F. C., and Bloemendal, H. (1991) Assembly of carboxy-terminally deleted desmin in vimentin-free cells. *European journal of cell biology* **56**, 84-103
414. Le, H., Browning, K. S., and Gallie, D. R. (2000) The phosphorylation state of poly(A)-binding protein



- specifies its binding to poly(A) RNA and its interaction with eukaryotic initiation factor (eIF) 4F, eIFiso4F, and eIF4B. *J Biol Chem* **275**, 17452-17462
415. Ma, S., Musa, T., and Bag, J. (2006) Reduced stability of mitogen-activated protein kinase kinase-2 mRNA and phosphorylation of poly(A)-binding protein (PABP) in cells overexpressing PABP. *J Biol Chem* **281**, 3145-3156
416. Grosso, S., Volta, V., Sala, L. A., Vietri, M., Marchisio, P. C., Ron, D., and Biffo, S. (2008) PKCbetaII modulates translation independently from mTOR and through RACK1. *The Biochemical journal* **415**, 77-85
417. Kielbassa, K., Muller, H. J., Meyer, H. E., Marks, F., and Gschwendt, M. (1995) Protein kinase C delta-specific phosphorylation of the elongation factor eEF-alpha and an eEF-1 alpha peptide at threonine 431. *J Biol Chem* **270**, 6156-6162
418. Mazroui, R., Di Marco, S., Kaufman, R. J., and Gallouzi, I. E. (2007) Inhibition of the ubiquitin-proteasome system induces stress granule formation. *Mol Biol Cell* **18**, 2603-2618
419. Angenstein, F., Evans, A. M., Settlage, R. E., Moran, S. T., Ling, S. C., Klintsova, A. Y., Shabanowitz, J., Hunt, D. F., and Greenough, W. T. (2002) A receptor for activated C kinase is part of messenger ribonucleoprotein complexes associated with polyA-mRNAs in neurons. *J Neurosci* **22**, 8827-8837
420. Barnett, M. E., Madgwick, D. K., and Takemoto, D. J. (2007) Protein kinase C as a stress sensor. *Cell Signal* **19**, 1820-1829
421. Chou, W. H., and Messing, R. O. (2005) Protein kinase C isozymes in stroke. *Trends in cardiovascular medicine* **15**, 47-51
422. Ytrehus, K., Liu, Y., and Downey, J. M. (1994) Preconditioning protects ischemic rabbit heart by protein kinase C activation. *The American journal of physiology* **266**, H1145-1152
423. Sakaki, K., Wu, J., and Kaufman, R. J. (2008) Protein kinase Ctheta is required for autophagy in response to stress in the endoplasmic reticulum. *J Biol Chem* **283**, 15370-15380
424. Atlas, R., Behar, L., Elliott, E., and Ginzburg, I. (2004) The insulin-like growth factor mRNA binding-protein IMP-1 and the Ras-regulatory protein G3BP associate with tau mRNA and HuD protein in differentiated P19 neuronal cells. *J Neurochem* **89**, 613-626
425. Gorospe, M., Kumar, S., and Baglioni, C. (1993) Tumor necrosis factor increases stability of interleukin-1 mRNA by activating protein kinase C. *J Biol Chem* **268**, 6214-6220
426. Park, J. W., Jang, M. A., Lee, Y. H., Passaniti, A., and Kwon, T. K. (2001) p53-independent elevation of p21 expression by PMA results from PKC-mediated mRNA stabilization. *Biochem Biophys Res Commun* **280**, 244-248
427. Perrone-Bizzozero, N. I., Cansino, V. V., and Kohn, D. T. (1993) Posttranscriptional regulation of GAP-43 gene expression in PC12 cells through protein kinase C-dependent stabilization of the mRNA. *J Cell Biol* **120**, 1263-1270