



LUND UNIVERSITY

Gas spectroscopy and optical path-length assessment in scattering media using a frequency-modulated continuous-wave diode laser

Mei, Liang; Jayaweera, Hiran; Lundin, Patrik; Svanberg, Sune; Somesfalean, Gabriel

Published in:
Optics Letters

DOI:
[10.1364/OL.36.003036](https://doi.org/10.1364/OL.36.003036)

2011

[Link to publication](#)

Citation for published version (APA):

Mei, L., Jayaweera, H., Lundin, P., Svanberg, S., & Somesfalean, G. (2011). Gas spectroscopy and optical path-length assessment in scattering media using a frequency-modulated continuous-wave diode laser. *Optics Letters*, 36(16), 3036-3038. <https://doi.org/10.1364/OL.36.003036>

Total number of authors:
5

General rights

Unless other specific re-use rights are stated the following general rights apply:
Copyright and moral rights for the publications made accessible in the public portal are retained by the authors and/or other copyright owners and it is a condition of accessing publications that users recognise and abide by the legal requirements associated with these rights.

- Users may download and print one copy of any publication from the public portal for the purpose of private study or research.
- You may not further distribute the material or use it for any profit-making activity or commercial gain
- You may freely distribute the URL identifying the publication in the public portal

Read more about Creative commons licenses: <https://creativecommons.org/licenses/>

Take down policy

If you believe that this document breaches copyright please contact us providing details, and we will remove access to the work immediately and investigate your claim.

LUND UNIVERSITY

PO Box 117
221 00 Lund
+46 46-222 00 00

Gas spectroscopy and optical path-length assessment in scattering media using a frequency-modulated continuous-wave diode laser

Liang Mei,^{1,2,3,*} Hiran Jayaweera,¹ Patrik Lundin,¹ Sune Svanberg,^{1,3} and Gabriel Somesfalean^{1,2,3}

¹Division of Atomic Physics, Department of Physics, Lund University, SE-221 00 Lund, Sweden

²Centre for Optical and Electromagnetic Research, Zhejiang University, Hangzhou 310058, China

³Joint Research Center of Photonics, Zhejiang University-Royal Institute of Technology-Lund University, Hangzhou 310058, China

*Corresponding author: liang.mei@fysik.lth.se

Received June 7, 2011; revised July 8, 2011; accepted July 14, 2011;
posted July 15, 2011 (Doc. ID 148863); published August 5, 2011

Simultaneous assessment of the spectroscopic absorption signal of gas enclosed in a scattering medium and the corresponding optical path length of the probing light is demonstrated using a single setup. Sensitive gas absorption measurements are performed by a tunable diode laser using wavelength-modulation spectroscopy, while the path length is evaluated by the frequency-modulated cw technique commonly used in the field of telecommunication. Proof-of-principle measurements are demonstrated with water vapor as the absorbing gas and using polystyrene foam as an inhomogeneously scattering medium. The combination of these techniques opens up new possibilities for straightforward evaluation of gas presence and exchange in scattering media. © 2011 Optical Society of America

OCIS codes: 290.4210, 300.1030.

Tunable diode laser absorption spectroscopy has found many applications in diverse fields [1]. The presence and exchange of gases enclosed in scattering media can be assessed by using tunable diode lasers in combination with the gas in scattering media absorption spectroscopy (GASMAS) technique [2]. During recent years, GASMAS has been successfully developed and applied in various fields, e.g., medical diagnostics [3], the monitoring of wood-drying processes [4], pharmaceutical analysis [5], and food science [6,7]. As given by the Beer-Lambert law, the absorption signal of a gas depends on its concentration as well as the path length that the light has travelled. In previous applications, two methods were utilized to evaluate the path length in scattering media: One approach is to use a reference gas with known concentration, from which the mean optical path length in the scattering material can be calculated and utilized to infer the unknown concentration of another gas. However, this approach requires a critical assumption, namely that the mean path length is the same for light with wavelengths matching the absorption of the two gases under consideration. Another method for path-length assessment is based on time-of-flight spectroscopy [8]. Thereby, a short-pulsed laser is used to measure the decay curve of the light passing through the scattering medium. The broadband characteristic of this technique implies, however, that a setup very different from that of GASMAS is required.

Finding a method to obtain the optical path length in scattering porous media using a single system, i.e., the one employed for measuring gas absorption, would be desirable. We demonstrate such a method, for the first time to our knowledge, by using a tunable diode laser where the absorption signal is retrieved by wavelength-modulation spectroscopy (WMS) [9] using a lock-in amplifier. The path-length distribution is determined using a frequency-modulated cw (FMCW) technique, which was previously demonstrated [10] and is based

on a Mach-Zehnder interferometer, well known from the optical communication [11] and fiber sensor fields [12,13].

The measurement principle is shown in Fig. 1(a). The frequency of the laser beam is modulated by a ramp signal with a modulation period of T_m and a modulation range of $\Delta\nu$. The laser beam is divided into two paths—the reference path and the sample path using a beam splitter (BS). The sample beam passes through a scattering medium, where the light is multiply scattered and thus becoming diffuse. Because of the scattering inside the medium, the sample beam photons travel a longer path length than the reference beam, which means a longer travelling time, τ . When the sample and reference waves finally arrive at the detector, they interfere with each other, and due to the different traveling times a delay-dependent beat signal will be induced as shown in Fig. 1(b). The beat frequency can be described as [14]

$$f_b = \Delta\nu \text{OPD} / cT_m, \quad (1)$$

where c is the light speed in the medium and OPD is the optical path-length difference between the sample and the reference wave. However, due to the heavy scattering inside the porous medium, the photons will travel in many different directions and may be scattered several times before heading for the detector, which means that,

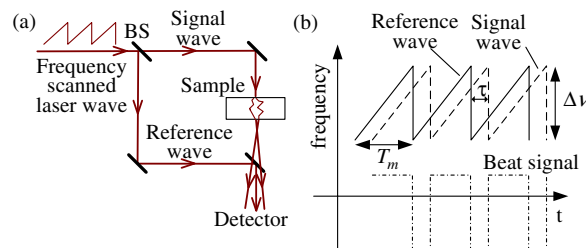

Fig. 1. (Color online) Scheme of path-length measurements using the FMCW technique.

instead of one single beat frequency, as obtained from, e.g., a fiber joint in an optical cable, a beat frequency distribution will be obtained. This frequency spectrum, however, corresponds to the amplitude of the sample wave [10]. By using the square of the frequency distribution, which describes the photon intensity for different optical path lengths, the OPD distribution can be calculated. Since only photons with parallel paths can interfere, the OPD distribution corresponds to a subset of the emerging sample wave photons that finally are parallel with the reference wave photons after the last scattering event, while other scattered photons will merely induce an offset intensity to the beat signal and can be treated as noise. One way to discriminate against nonparallel scattered photons is to place a small aperture on the transmission side in front of a distant detector. Such an aperture results in “tunnel vision” as in the case of a laser radar telescope. All photons emerging from the same volume, however, are representative for how light travels inside a strongly scattering medium and can thus be used for path-length assessment. Thus, the weak absorption signal of the gas can favorably be detected by using a large aperture, which increases photon collection and thereby the signal-to-noise ratio.

A proof-of-principle experiment was performed on a set of polystyrene foam slabs with different thicknesses. Water vapor inside the polystyrene foams was measured at an absorption line of 937.4036 nm (vacuum wavelength). The experimental setup is shown in Fig. 2. The linewidth of the diode laser (Eagleyard Photonics, EYP-DFB-0937, 110 mW) used is 10 MHz, thus guaranteeing a coherence length of 30 m, which is sufficient to obtain a beat signal. The setup can easily be switched between gas absorption and path-length measurement modes, respectively, by manually adjusting a switch and a chopper—both could readily be replaced by electric counterparts. The WMS [9] technique was used to retrieve the gas absorption imprint. The diode laser was wavelength scanned by a 7 Hz ramp signal in a frequency range of 35 GHz over the absorption spectrum of water vapor and modulated with a superposed 9 kHz sine signal for WMS-based noise reduction with a time constant of 1 ms.

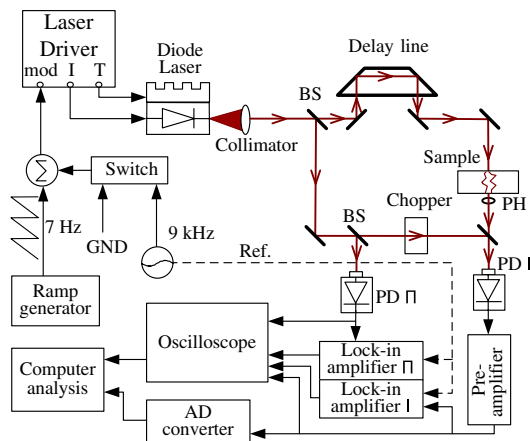

Fig. 2. (Color online) Experimental setup. PD I, Photodiode I; PD II, photodiode II; BS, beam splitter; GND, ground; PH, pinhole; mod, modulation input; I, current driver input; T, temperature driver input; Ref., reference signal for the lock-in amplifiers.

The sample wave was detected by a photodiode (PD I) (Thorlabs, DET 110 M), working in a voltage bias mode, while the manual chopper was turned off to block the reference light wave of the Mach-Zehnder interferometer. The reference light wave was detected by another photodiode (PD II) of the same type. The $2f$ absorption signals were picked up by two lock-in amplifiers and then sampled by an oscilloscope that transferred the data into a computer for analysis. After the absorption measurement, the switch was manually turned to ground (GND), and the chopper was opened. To ensure that only parallel photons were collected in the interference experiment, the sample wave was restricted by an optical tunnel. This comprised a pinhole (PH), with 3.6 mm diameter, and PD I, with an effective area of 3.6 mm \times 3.6 mm located 310 mm from each other. The interference signal was detected by PD I operating without any voltage bias, thereby cutting off the interference background. The beat signal was sampled by an analog-digital (AD) converter and analyzed on the computer.

A set of ten pieces of polystyrene foam with thicknesses ranging from 7 to 20.3 mm were used as samples. A measurement without any sample, corresponding to a sample thickness of 0 mm, was also performed. During the experiments, the room temperature was kept at $25.7(\pm 0.3)^\circ\text{C}$ and the relative humidity was $43.5(\pm 0.3)\%$, which means that the change of water vapor concentration during the experiments was negligible. Since the polystyrene foam has open pores, we consider that the gas enclosed in the material was in equilibrium with the surrounding atmosphere.

The mean frequency was calculated from the weighted average of the square of the frequency distribution. As we

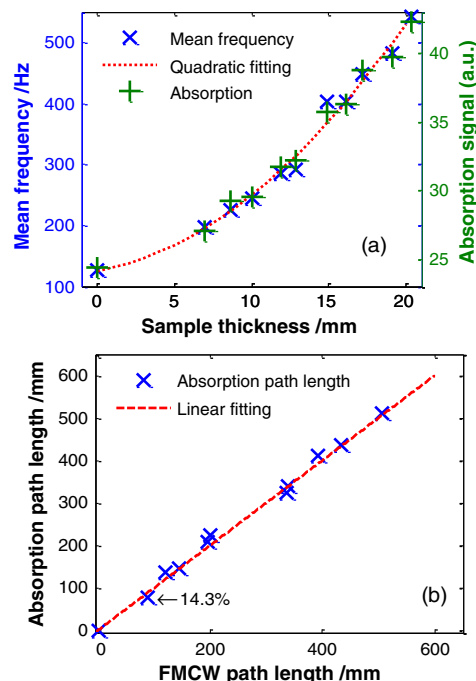

Fig. 3. (Color online) Experimental results: (a) mean frequency, quadratic fit of the mean frequency, and the absorption signal versus sample thicknesses; (b) mean optical path lengths calculated from the gas absorption and the mean beat frequency.

can see from Fig. 3(a), both the mean frequency and the gas absorption signal are increasing as the square of the sample thickness increases, as expected [8]. The mean frequency offset for a sample thickness of 0 mm is due to the delay line. The path length in free air (without any sample) is 694 mm, which also induces an offset in the gas absorption signal due to the ambient water vapor. The mean path lengths due to the scattering of the polystyrene foam samples can be calculated in two different ways: One is using the water vapor absorption signal, since it is proportional to the optical path length, and another alternative method is using the relationship between the mean beat frequency and the optical path length, which was calibrated by translating the delay line. It was found that 1.22 mm OPD corresponds to 1.00 Hz mean frequency. As shown in Fig. 3(b), a linear relationship between these two different path-length calculation methods is obtained. Since the porosity of the polystyrene foam is very high [8], the path lengths obtained from the two methods are also the same.

The maximum deviation—defined as the ratio between the path-length difference and the average path length of the two methods—was found to be 14.3% for a sample thickness of 7 mm. The rather large deviation in the case of small sample thicknesses can be partly explained by the nonuniform surfaces of the polystyrene foams used. Since the samples were vibrated (by a small asymmetrically weighted electric motor) when measuring gas absorption to avoid interference fringes, this caused the laser beam to illuminate slightly different positions when measuring the beat frequency and the gas absorption. This kind of deviation can be reduced by using a well-controlled mechanical vibration setup. Another reason for a larger relative error for the thinner slabs is the smaller absorption signal, which is more affected by, e.g., interference fringes.

The experimental results show that a combination of the FMCW and the GASMAS techniques can provide enough information, i.e., gas absorption and optical path length, to get information on the enclosed gas concentration inside a scattering medium. The FMCW technique provides information about the total optical path length, while the absorption depends only on the path length through gas. Thus, a prerequisite should be that the medium is “quasi-homogenous” (i.e., homogenous on a large macroscopic scale) for the technique to be fully

applicable. The path length measured by the GASMAS technique is expected to be smaller than the path length measured by the FMCW technique in a low porosity scattering medium. In addition, the combination of these techniques can be used to study the porosity or optical properties of turbid media as also discussed in [5]. Generally, the proposed techniques open up the possibility of direct and convenient measurement of gas presence and exchange in application fields such as food science, materials characterization, and medical diagnostics.

The authors gratefully acknowledge discussions with M. Lewander, X. T. Lou, and L. Cocola. This work was supported by a direct Swedish Research Council grant, a Linnaeus grant to the Lund Laser Centre, and an Erasmus Mundus Programme scholarship.

References

1. K. S. Song and E. C. Jung, *Appl. Spectrosc. Rev.* **38**, 395 (2003).
2. M. Sjöholm, G. Somesfalean, J. Alnis, S. Andersson-Engels, and S. Svanberg, *Opt. Lett.* **26**, 16 (2001).
3. L. Persson, M. Lewander, M. Andersson, K. Svanberg, and S. Svanberg, *Appl. Opt.* **47**, 2028 (2008).
4. M. Andersson, L. Persson, M. Sjöholm, and S. Svanberg, *Opt. Express* **14**, 3641 (2006).
5. T. Svensson, M. Andersson, I. Rippe, S. Svanberg, S. Andersson-Engels, J. Johansson, and S. Folestad, *Appl. Phys. B* **90**, 345 (2008).
6. L. Persson, H. Gao, M. Sjöholm, and S. Svanberg, *Opt. Lasers Eng.* **44**, 687 (2006).
7. M. Lewander, Z. G. Guan, L. Persson, A. Olsson, and S. Svanberg, *Appl. Phys. B* **93**, 619 (2008).
8. G. Somesfalean, M. Sjöholm, J. Alnis, C. af Klinteberg, S. Andersson-Engels, and S. Svanberg, *Appl. Opt.* **41**, 3538 (2002).
9. S. Schilt, L. Thevenaz, and P. Robert, *Appl. Opt.* **42**, 6728 (2003).
10. Z. G. Guan, P. Lundin, and S. Svanberg, *Opt. Express* **17**, 16291 (2009).
11. U. Glombitza and E. Brinkmeyer, *J. Lightwave Technol.* **11**, 1377 (1993).
12. M. Zavrsnik and G. Stewart, *J. Lightwave Technol.* **18**, 57 (2000).
13. M. Jiang, D. R. Chen, and S. L. He, *IEEE Photon. Technol. Lett.* **20**, 1962 (2008).
14. J. Zheng, in *Optical Frequency-Modulated Continuous-Wave (FMCW) Interferometry*, W. T. Rhodes, ed. (Springer, 2005), pp. 20–24.