



LUND UNIVERSITY

Calculation of the moisture-time fields in concrete

Fagerlund, Göran; Hedenblad, Göran

1993

[Link to publication](#)

Citation for published version (APA):

Fagerlund, G., & Hedenblad, G. (1993). *Calculation of the moisture-time fields in concrete*. (Report TVBM; Vol. 3052). Division of Building Materials, LTH, Lund University.

Total number of authors:

2

General rights

Unless other specific re-use rights are stated the following general rights apply:

Copyright and moral rights for the publications made accessible in the public portal are retained by the authors and/or other copyright owners and it is a condition of accessing publications that users recognise and abide by the legal requirements associated with these rights.

- Users may download and print one copy of any publication from the public portal for the purpose of private study or research.
- You may not further distribute the material or use it for any profit-making activity or commercial gain
- You may freely distribute the URL identifying the publication in the public portal

Read more about Creative commons licenses: <https://creativecommons.org/licenses/>

Take down policy

If you believe that this document breaches copyright please contact us providing details, and we will remove access to the work immediately and investigate your claim.

LUND UNIVERSITY

PO Box 117
221 00 Lund
+46 46-222 00 00



LUND INSTITUTE OF TECHNOLOGY
Division of Building Materials

CALCULATION OF THE MOISTURE-TIME FIELDS IN CONCRETE

Göran Fagerlund & Göran Hedenblad

CALCULATION OF THE MOISTURE-TIME FIELDS IN CONCRETE

Göran Fagerlund & Göran Hedenblad

Preface

This report is produced within the BRITE/EURAM project BREU-CT92-0591 "The Residual Service Life of Concrete Structures".

Five partners are involved in the project:

- 1: British Cement Association. (The coordinator).
- 2: Instituto Eduardo Torroja, Spain.
- 3: Geocisa, Spain.
- 4: Swedish Cement and Concrete Research Institute.
- 5: Cements AB, Sweden.
- 6: Div. Building Materials, Lund Inst. of Technol., Sweden.

Three deterioration mechanisms are treated in the project:

- 1: Corrosion of reinforcement.
- 2: Freeze-thaw effects.
- 3: Alkali silika reaction.

This report refers to Task 1 of the work, "Definition of the aggressivity of the environment" ; sub-task 1.2 "Freeze-thaw".

Only the moisture profiles are treated in the report. It will be followed by a report in which the combined effect of moisture and other diffusing agents -chlorides, carbon dioxide and oxygen- are analyzed.

Lund 31 March 1993.

Göran Fagerlund

Summary

The moisture level and variations in the surface part of the concrete are of decisive importance for its service life. They determine the diffusion of aggressive agents into the concrete and they determine the electrical resistivity of the concrete. They also determines the risk and degree of of frost damage and alkali-silica reaction.

The moisture variations can be estimated by computer calculations provided the outer moisture conditions and the moisture diffusivity of the concrete and its variation with the moisture level of the concrete are known. The result of a number of such calculations are presented in the report. The computer program used gives the maximum, minimum and average levels of the relative humidity as a function of the distance from the concrete surface. From these limiting RH-profiles the relative duration of a certain RH can be estimated. The RH-profiles can be used for a calculation of the diffusion of "aggressive media" into the concrete when the relation between the diffusivity of each medium and RH is known.

In the calculation new data for the moisture diffusivity of portland cement concretes, including moisture transport due to capillary suction, has been utilized. The data are based on a new experimental technique which, for the first time, provide reliable moisture diffusivities also for the high RH-range (RH 90 to 100%).

The outer climate conditions are supposed to be cyclic and step-wise varying between a high RH-level (95 or 100%) and a low RH-level (60 or 80%). Many different types of variation are considered; from long periods of drying combined with short periods of wetting to short periods of drying followed by long periods of wetting. Other moisture variations and other temperature levels can be easily considered by simply changing the length-scale of the moisture-profile.

1. Moisture content and service life

The moisture condition in a certain unit element inside the concrete can be expressed in terms of the relative humidity (RH) within the same element. The relation between RH and moisture condition is given by the sorption isotherm the principles of which are shown in Fig 1.1. Equilibrium adsorption and desorption isotherms for mature OPC-concrete are fairly well-known; see Fig 1.2 which is based on Powers' and Brownyard's /1/ and Nilsson's /2/ work. Isotherms have also been experimentally determined for concretes with silica fume by Sellevold et al /3/ and for concretes with fly ash by Xu /4/.

Diffusion of gases such as CO_2 or O_2 through the unit element is highly dependent of the RH; the higher the RH the higher the water content and the lower the diffusivity of gases. The effect of RH is at least as large as the effect of the w/c-ratio. Some measurements are shown in Fig 1.3; Tuutti /5/. According to these measurements the effect on the diffusivity of a decrease in RH from 100 % to 50 % is almost 2 orders of magnitude. The reason is of course that the diffusivity of a gas through an air phase is at least 100 times as high as the diffusivity through a water phase.

This means that the service life before the onset of corrosion due to carbonation is to a very high degree dependent of the moisture-time field across the concrete cover before start of corrosion; this determines the rate of CO_2 -ingress and thus the rate of carbonation. Similarly, the corrosion time until spalling of the concrete cover is mainly dependent of the moisture-time field in the cover after start of corrosion; this determines the supply of oxygen and it determines the electrical resistivity of the concrete. In Fig 1.4 the principal effect of RH on the electrical resistivity is shown.

The chloride diffusion behaves quite differently. It is most rapid when the concrete is water saturated and is probably very low when the pore water does no longer form a continuous phase through the concrete. This happens at a certain critical moisture content or critical RH that is probably a function of the w/c-ratio. Unfortunately, the relation between RH and the chloride diffusivity is unknown. In Fig 1.5 a possible variation is shown.

When the moisture-time field and the diffusivity-RH relations are known, the penetration rate of the "aggressive media" (CO_2 , Cl^- and O_2) can be calculated by traditional numerical methods or even, in simple cases, be calculated analytically.

Knowledge of the moisture conditions around the reinforcement bars and the time-variation in these is also valuable for the estimation of the critical chloride content. This is probably to a certain extent dependent of the moisture content and stability. Therefore the moisture around the bars is a major factor for the service life with regard to reinforcement corrosion.

It is evident that a service life prediction with regard to reinforcement corrosion cannot be made if it is not possible to predict the future moisture condition. In the case of an old structure, however, the pre-history can be used for a prediction under the condition that the environmental conditions that have prevailed during the pre-history of the structure do not change in the future.

The alkali-silica reaction is also dependent of the moisture content. In this case, however, the most severe attack occurs at very high moisture contents (RH \approx 100%). The relation between the degree of attack and RH is unknown to the author. The calculation technique presented in this report can however be used even in this case for estimating the inflow of water and the RH-level on different depths from the surface. Then, it ought to be possible to make a fair estimation of the rate of reaction.

Frost attack does only occur when the moisture content is very high (100 %). Not only the capillary pores must be water-filled but also some of the compaction pores or entrained airpores. The technique presented in this report can only be used for estimating the duration of the moisture level RH 100 %. The gradual filling of the coarse compaction pores or airpores can then be estimated by another theory; see a report within this BRITE/EURAM project /6/.

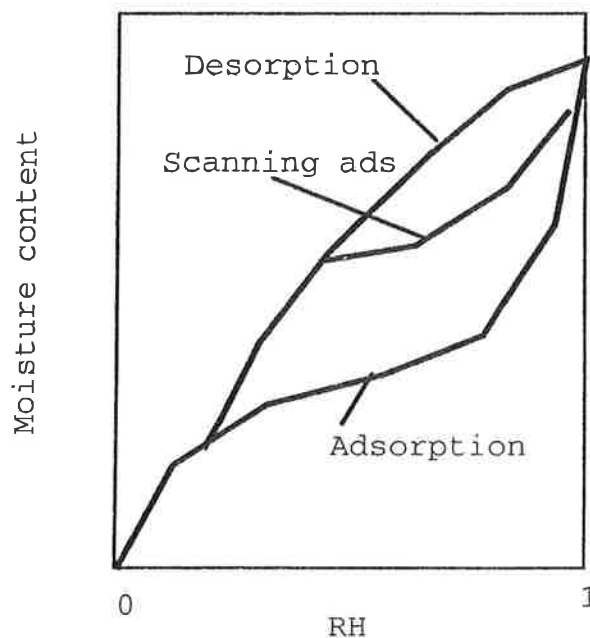

Fig 1.1: Sorption isotherms; principally.

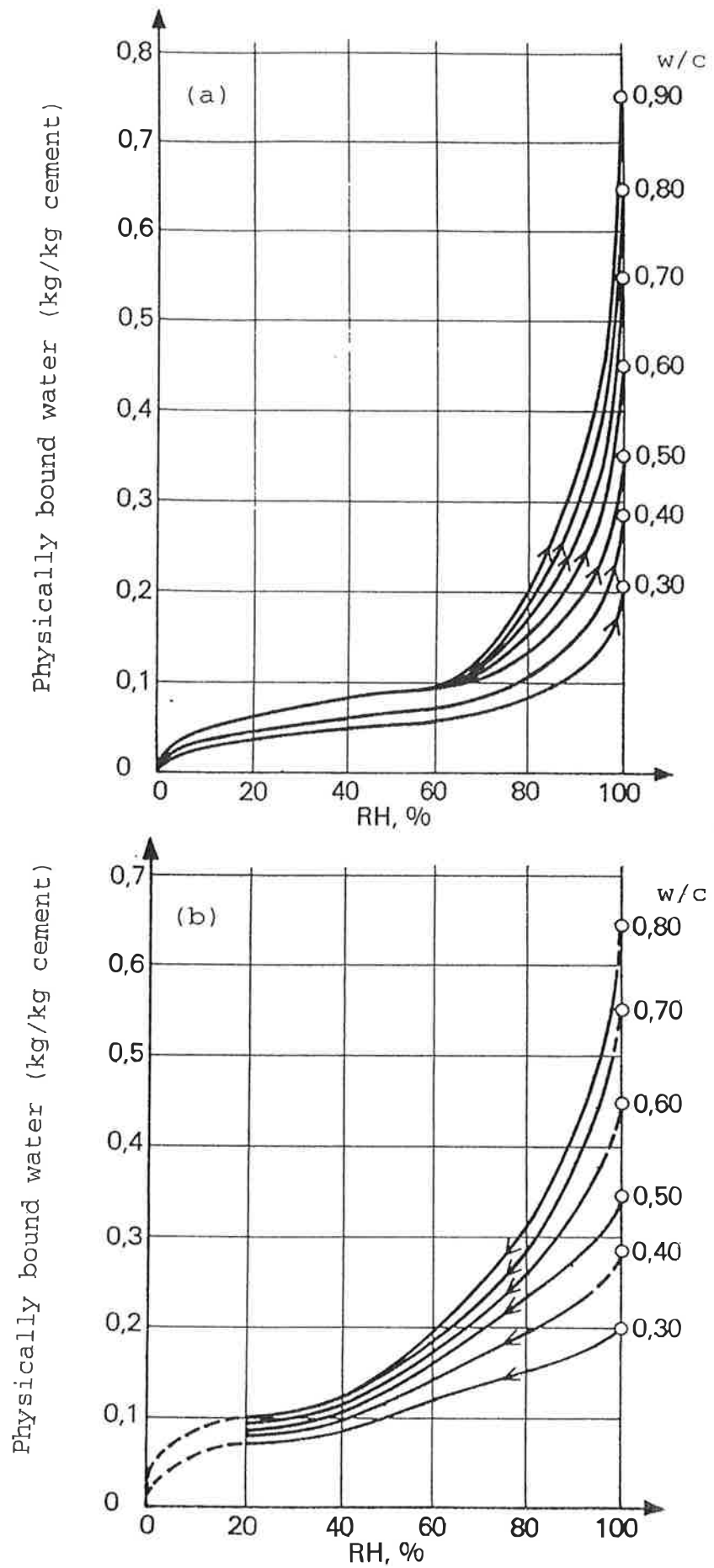

Fig 1.2: Sorption isotherms for mature concrete.
 (a) Adsorption isotherms; Powers and Brownyard /1/.
 (b) Desorption isotherms; Nilsson /2/.

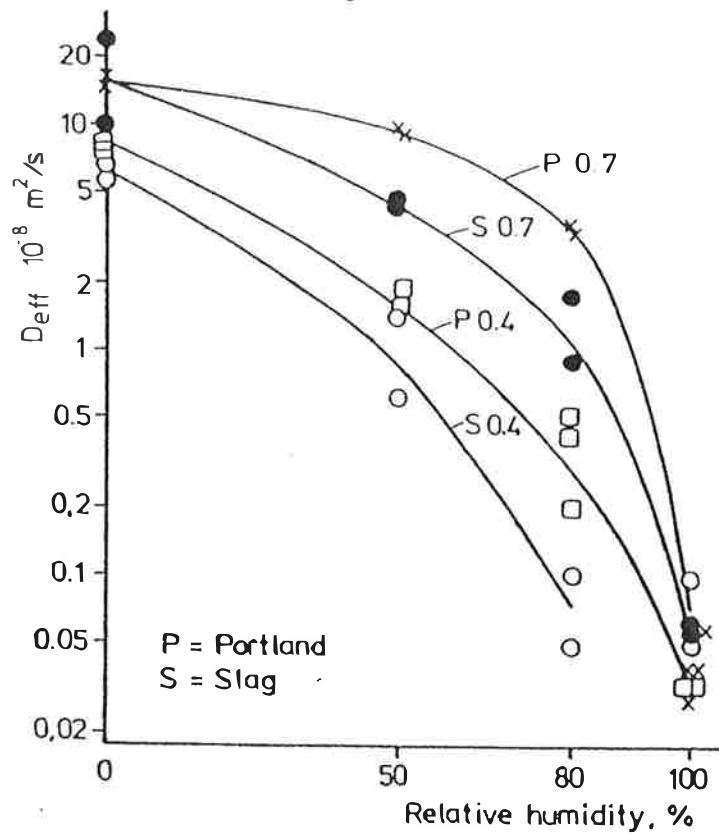

Fig 1.3: Effect of RH on the diffusivity of oxygen through portland cement concrete (P) and slag cement concrete (S); Tuutti /5/. (The figure at the curve is the w/c-ratio).

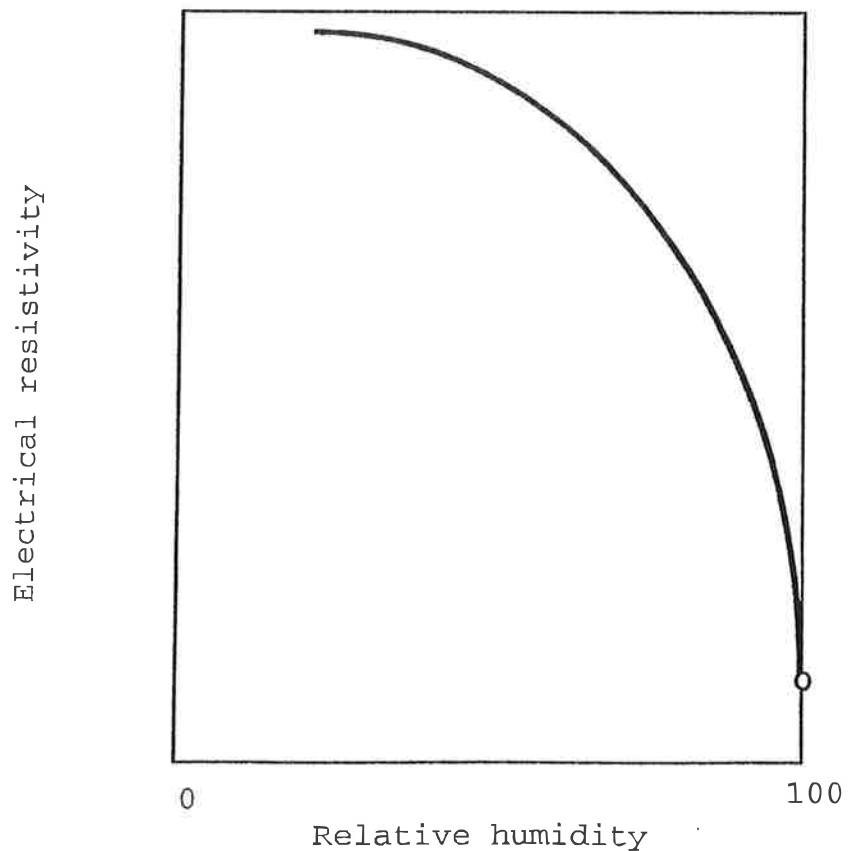

Fig 1.4: Effect of RH on the electrical resistivity of concrete, principally.

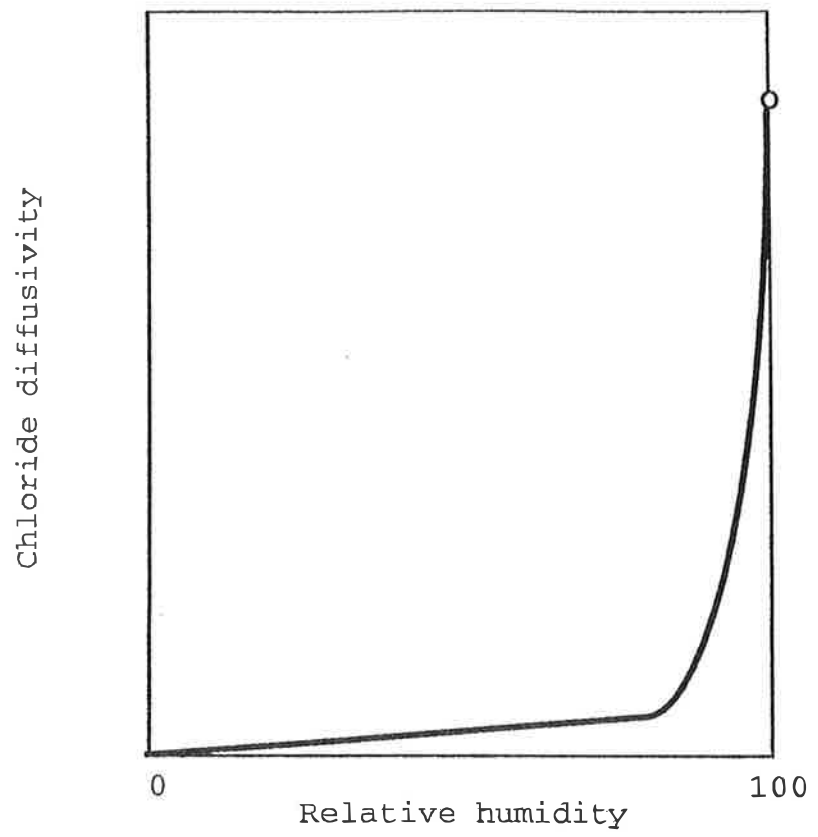

Fig 1.5: Effect of RH on the chloride diffusivity; principally.

2. Moisture transfer

Moisture migration under steady state conditions is calculated by

$$q = -\delta_v \cdot \frac{dc}{dx} \quad (2.1)$$

where q is the moisture flux

δ_v is the moisture diffusivity (including capillarity)

dc/dx is the gradient in moisture content, vapour pressure or vapour concentration.

Under non-steady state conditions, consideration must also be taken to the moisture capacity of the material. The following general equation is used for calculating the moisture flux:

$$q = \delta_v \cdot \frac{d^2c}{dx^2} \quad (2.2)$$

The coefficient δ_v depends on the gradient selected, which is normally vapour concentration:

$$\delta_v = f(\Phi, \theta) \quad (2.3)$$

where Φ is the relative humidity RH ($0 \leq \Phi \leq 1$)

θ is the temperature ($^{\circ}\text{C}$ or $^{\circ}\text{K}$)

Thus, the moisture flux is a function not only of the moisture gradient but also of RH and the temperature level.

The temperature **gradient** effect on the moisture transfer is neglected in the calculations since the temperature fields regarded in this study change very slowly; the "time coefficient" is of the size order days or weeks. Thus, the temperature gradients inside the concrete are very small. Besides, temperature gradients are probably always of much less importance for moisture transport than are moisture gradients.

Input in the calculations are material data and boundary conditions; i.e. the outer climatic conditions. They are treated in the next two paragraphs.

3. Material data

3.1 The diffusivity versus RH; $\delta_v = f(\Phi)$

The relation has the general shape shown in Fig 3.1 when moisture gradient is expressed in vapour concentration (kg/m^3). "Pure diffusion" takes place when RH is below about 95 to 99%. Capillary suction from a free water surface occurs at RH 100% (or somewhat below this value due to the fact that dissolved salts in the water lowers the saturation vapour pressure)

The coefficient $\delta_v(\Phi)$ within the diffusion range below about 95 to 99 % RH can be determined by three different methods:

- 1: The modified cup method in which a slice of the concrete is placed between two different RHs, one of which is kept constant. The other is varied between 30% and 100%. After each change in the variable RH, the slice is allowed to reach equilibrium. The rate of weight loss or gain at equilibrium gives the diffusivity. δ_v can be determined in the RH-range 50% to about 90% by this method.
- 2: The sorption method at which the time process of drying or wetting of a concrete slice is monitored. The mean value of the diffusivity, $\delta_{v,\text{mean}}$, over a certain RH-interval can be estimated by comparing the measured sorption curve with the theoretical solution of the diffusion equation. This can for example be found in Crank /7/.
- 3: The equilibrium method at which a rather thick slice of the concrete is placed between two RH, one of which is 100%. The RH-profile across the specimen is measured when the specimen has come to equilibrium, which can take more than one year. From the RH-profile, δ_v can be calculated over a very large RH-span; 30% to 100%. The method is described in /8/.

Data from the third method will be used in the actual calculations; the data were determined by Hedenblad /8/.

The diffusivity at 100% is important since it determines the moisture ingress during very moist periods; rain, splashing water etc. It is determined by uni-directional capillary absorption experiments during which the time process of water uptake is measured. The 100%-diffusivity is found by computer simulations. The diffusivity value which as closely as possible simulates the really observed water uptake is chosen. The increase in diffusivity is found to be about 20-fold between the maximum diffusivity within the diffusion range below RH 95 to 99 % and the capillarity range at RH 100 %.

The methods for determination of the diffusivity data in the diffusion range and in the capillarity range are described in Appendix 1; paragraphs A2.1 and A2.4. The numerical values of the diffusivities are given in Hedenblad /8/. The values for 100 % RH are uncertain. Better values will be determined by new and more comprehensive capillarity experiments.

The lack of reliable data makes that only the following w/c-ratios have been regarded in this report, and only OPC-concretes.

1: With no free water on the surface; i.e. no capillarity:
w/c = 0,4, 0,5, 0,6 (0,7 will be included later)

2: With free water on the surface; i.e. capillarity is regarded:
w/c = 0,4, 0,6 (0,5 and 0,7 will be included later when the experimental results have been evaluated).

The calculations can easily be made also for other input data of the moisture diffusivity.

3.2 The diffusivity versus temperature; $\delta_v = f(\theta)$

The effect on the moisture flow of the temperature level is rather small. As an approximation, diffusion is regarded to be a thermally activated process with the "activation temperature" (E/R) equal to 2260 K. Then, the ratio of the diffusivities at temperature θ °C and 20 °C is:

$$\delta_{v,t} / \delta_{v,20} = \exp\{2260(1/293 - 1/(273 + \theta))\} \quad (3.1)$$

This gives the following relative diffusivities.

$\theta = 0$ C (273 K):	Diffusivity	$\approx 0,57$
$\theta = 10$ C (283 K):	-"-	$\approx 0,7$
$\theta = 20$ C (293 K):	-"-	$= 1,00$
$\theta = 30$ C (303 K):	-"-	$\approx 1,29$
$\theta = 40$ C (313 K):	-"-	$\approx 1,64$

Almost exactly the same relative diffusivities are obtained if moisture transfer is supposed to be a viscous flow determined by the viscosity of water and the surface tension water-air. Both those properties are temperature dependent.

A curve of the type seen in Fig 3.2 will be obtained. Below 0 °C the diffusivity is supposed to be zero since almost all water is frozen.

The effect of freezing on the diffusivity of CO₂, O₂ and chlorides is not known. Probably the diffusion of gases is not very much affected when RH is low but much retarded when the RH is above the limiting value RH_{CR} which signifies the transition from a discontinuous to a continuous water phase in the pore system. The chloride diffusion, is certainly very low when the pore water is frozen.

3.3 The sorption isotherms

The sorption isotherm is used in the calculation programme for considering the effect on the moisture state within a certain material element of a certain moisture loss from or moisture gain to the element. The typical shape of sorption isotherms is shown in Fig 1.1.

Equilibrium adsorption and desorption isotherms of OPC-concrete at room temperature have been determined by Powers & Brownyard /1/ and by Nilsson /2/ among others. Their isotherms are shown in Fig 1.2. The temperature effect on the "isotherms" can, as a first approximation, be neglected. Both the adsorption and the desorption isotherm as well as the scanning curves (see Fig 1.1) should be regarded in a stringent calculation. In the actual calculation only the desorption isotherm is considered. It has the shape shown in Fig A.6 in APPENDIX 1. It is based on Nilsson's desorption isotherms -see Fig 1.2(b)- but the upper part is changed a bit. The 100 % point in Nilsson's isotherm is moved to a somewhat lower RH which corresponds to the saturation-RH for the pore water considering that this contains dissolved alkali which lowers the vapour pressure. The deviation in RH from 100 % increases with decreasing w/c-ratio which is natural since the amount of alkali increases when the w/c-ratio is lowered, at the same time as the amount of pore water decreases. The isotherm between this new saturation point and 100 % RH is supposed to be horizontal, an assumption which might be questioned.

The sorption isotherm below the saturation point is coupled to the measured and used diffusivity in the diffusion range below about 100 %. The horizontal isotherm above the saturation point is fictive and only introduced for making a calculation of the capillary water transport, or saturated moisture flow, possible with the same computer programme as that which is used for non-saturated flow.

3.4 The thermal properties

The heat conductivity and the heat capacity of concrete are well-known from literature. Both properties are affected by the moisture level. This must probably be considered if a high precision in the prediction is needed. As a first approximation, however, all thermal properties are regarded constant.

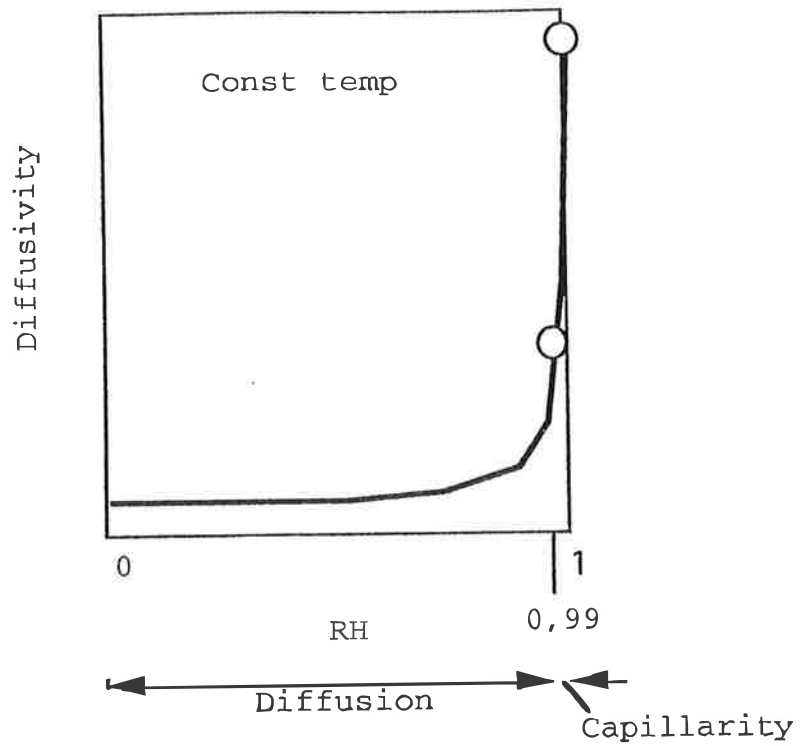

Fig 3.1: Effect of RH on the moisture diffusivity defined by eq (3.1); principally.

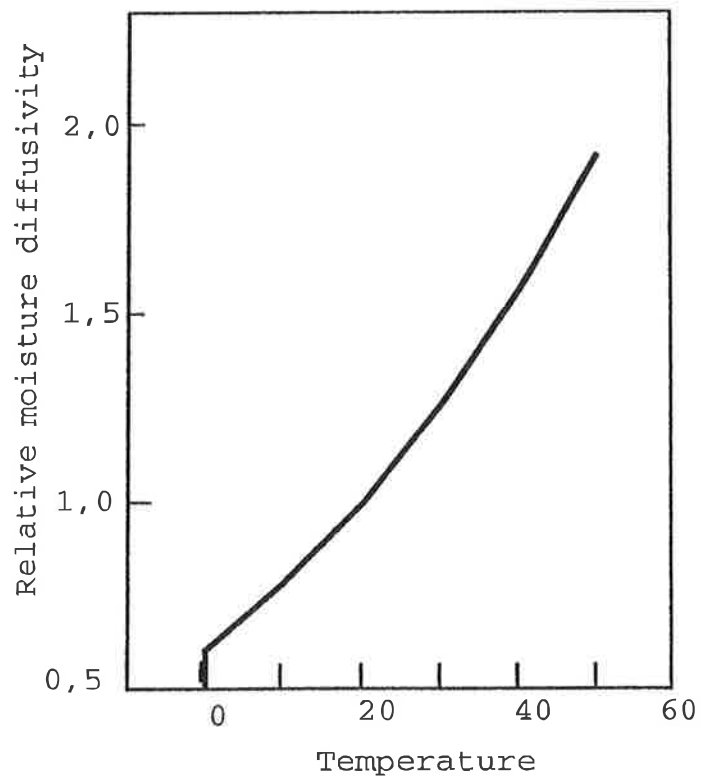

Fig 3.2: Effect of temperature on the diffusivity of moisture; principally.

4 Climate data needed

4.1 The outer moisture conditions

The real moisture variation is a complicated statistical function. Since we are only interested in long-term effects on the concrete, the real moisture variation can be replaced by a simple step-formed or sinusoidal cyclic variation in the outer RH. RH 100% means unlimited amount of water in contact with the concrete surface, such as heavy rain, wave splash etc.

A hypothetical real moisture variation and an example of a simulated step-shaped variation used in the calculation are shown in Fig 4.1. The step length at the low and high RH-levels is varied between 7 days and 28 days. The absolute level of the high RH is either 95 % (no rain or splash) or 100 % (rain or splash). The variations employed in the calculations are shown in paragraph 6 below and in APPENDICI 1 and 2.

The effect of other durations of the moisture cycle can be easily calculated by utilizing the solutions in the APPENDICI. The calculated moisture variation or "moisture funnel" at the surface is always the same but the "penetration depth" of the moisture variation or "moisture funnel" is depending on the duration. The method for considering other moisture variations is described in APPENDIX 1 paragraph A4.1. Some examples are given in paragraph 6.1.

4.2 The temperature

Since only long-term effects are considered, the real temperature spectrum can be transformed to an average sinusoidal variation or a stepwise cyclic variation with a period of 1 year or any other typical variation. A hypothetical example of a real and a simulated temperature variation are shown in Fig 4.2.

In the calculations made in this report, the temperature is supposed to be constant, +20 °C. Other constant temperatures can be easily considered by a method described in APPENDIX 1 paragraph A4.1. A lower average temperature causes the penetration depth of the moisture variation zone to decrease; i.e. the effect of changes in the outer moisture conditions are felt on a smaller depth from the surface.

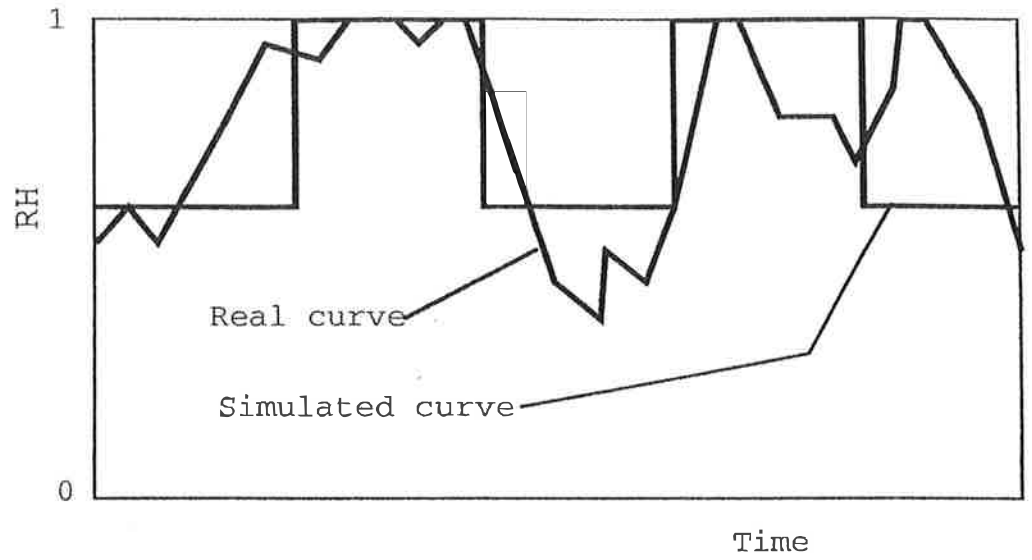

Fig 4.1: The real and a simulated variation of the outer moisture conditions.

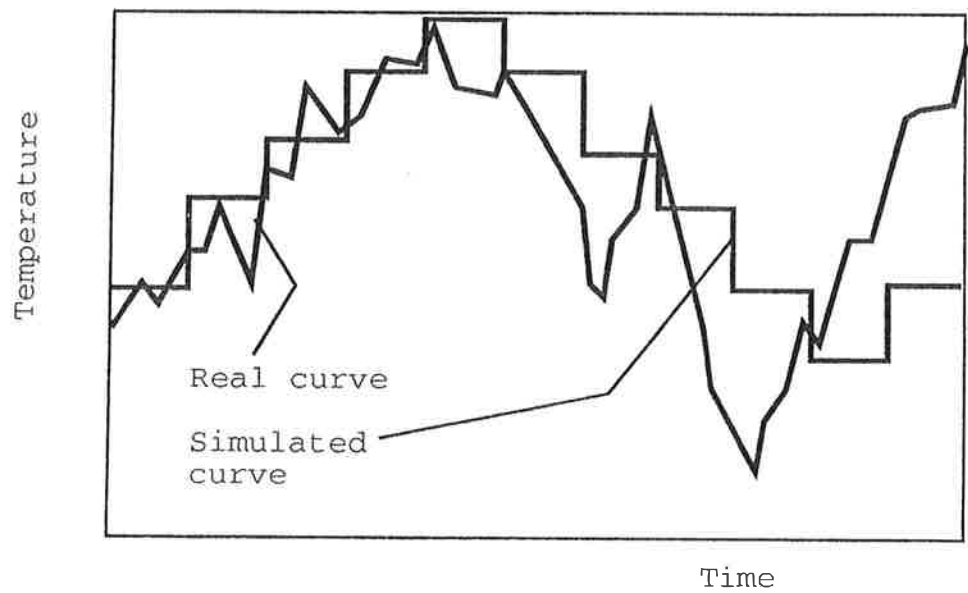

Fig 4.2: The real and a simulated variation of the outer temperature.

5. The calculation programme

The PC-programme used is designed in such a way that individual data for concrete and climate can be introduced. Principles behind the programme are described in /9/.

The programme can be used for a prediction of the temperature and moisture (RH) variation over the concrete cross-section at different points of time. Only one-dimensional flow is considered.

The detailed calculation will give the moisture profile at different points of time. The principal shape of such profiles is shown in Fig 5.1.

By such calculations also the duration of a certain moisture condition (RH) on a certain distance from the surface can be calculated. An hypothetical example of moisture duration curves is shown in Fig 5.2.

In the actual calculations presented in paragraph 6 and APPENDICI 1 and 2 such detailed information is not given. Only the maximum, the minimum and the average moisture and temperature condition on different depths from the concrete surface are presented. The real moisture condition at a certain depth from the surface will always lie between the upper and the lower limiting curves. This means that the duration of a certain RH on a certain level from the surface is not directly obtained in the calculations performed.

A highly approximative distribution function of the duration of a certain RH on a certain depth from the surface might be estimated by using the principles described in Fig 5.3.

* **At the surface ($x=0$)** the relative duration t_{\min} at RH_{\min} is equal to the time fraction that RH_{\min} takes up of the total outer moisture cycle used. This is 20 %, 33 %, 50 %, 67 % or 80 % in the examples described in paragraph 6.1 and in APPENDIX 1.

In the same manner the relative duration t_{\max} at RH_{\max} is equal to its fraction of the total outer moisture cycle. The distribution function between RH_{\min} and RH_{\max} is horizontal since the moisture change between RH_{\min} and RH_{\max} is abrupt.

* **On a larger depth than x_m** which is the depth where RH becomes constant the RH-distribution curve is vertical and equal to the mean value of RH ($RH=RH_m$).

* **On depths x_1 between the surface ($x=0$) and the depth where RH is constant ($x=x_m$)** the distribution is supposed to be composed of three lines constructed in the following way; see Fig 5.3. The lowest RH (RH_l) and the highest RH (RH_h) at a given distance $x=x_1$ from the surface are given by the calculated "moisture funnel". The duration of those moisture conditions

are given by the intersection of vertical lines with the sloping lines shown in Fig 5.3.

The relative duration distribution curves can be used for predictions of the future chloride profiles, the future penetration of the carbonation front or the inflow of water.

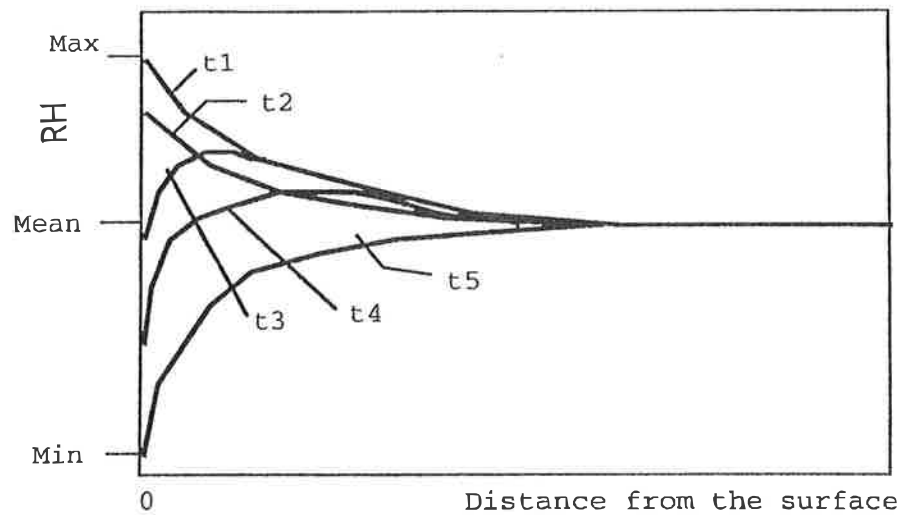

Fig 5.1: Hypothetical moisture-time profiles in the surface part of the concrete.

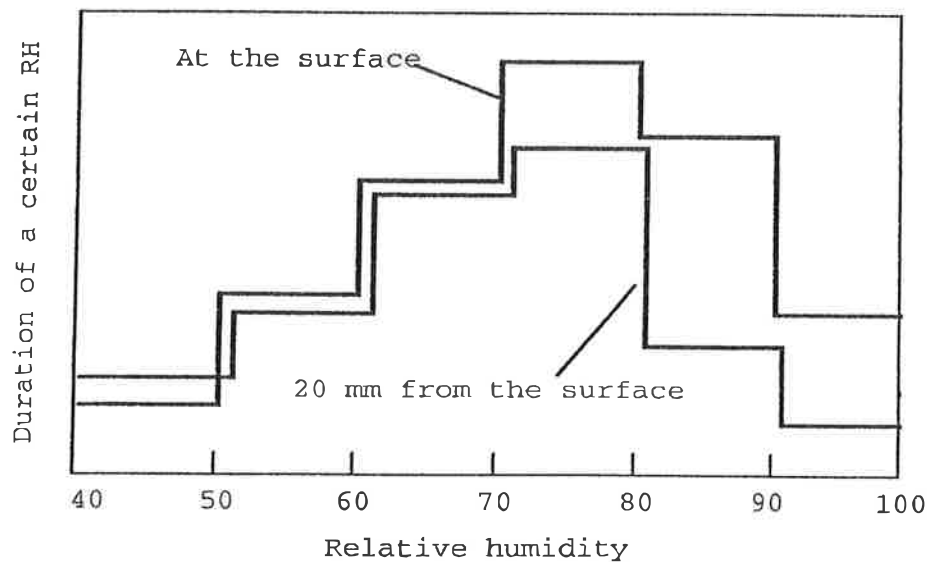

Fig 5.2: Duration of a certain RH at a certain distance from the surface.

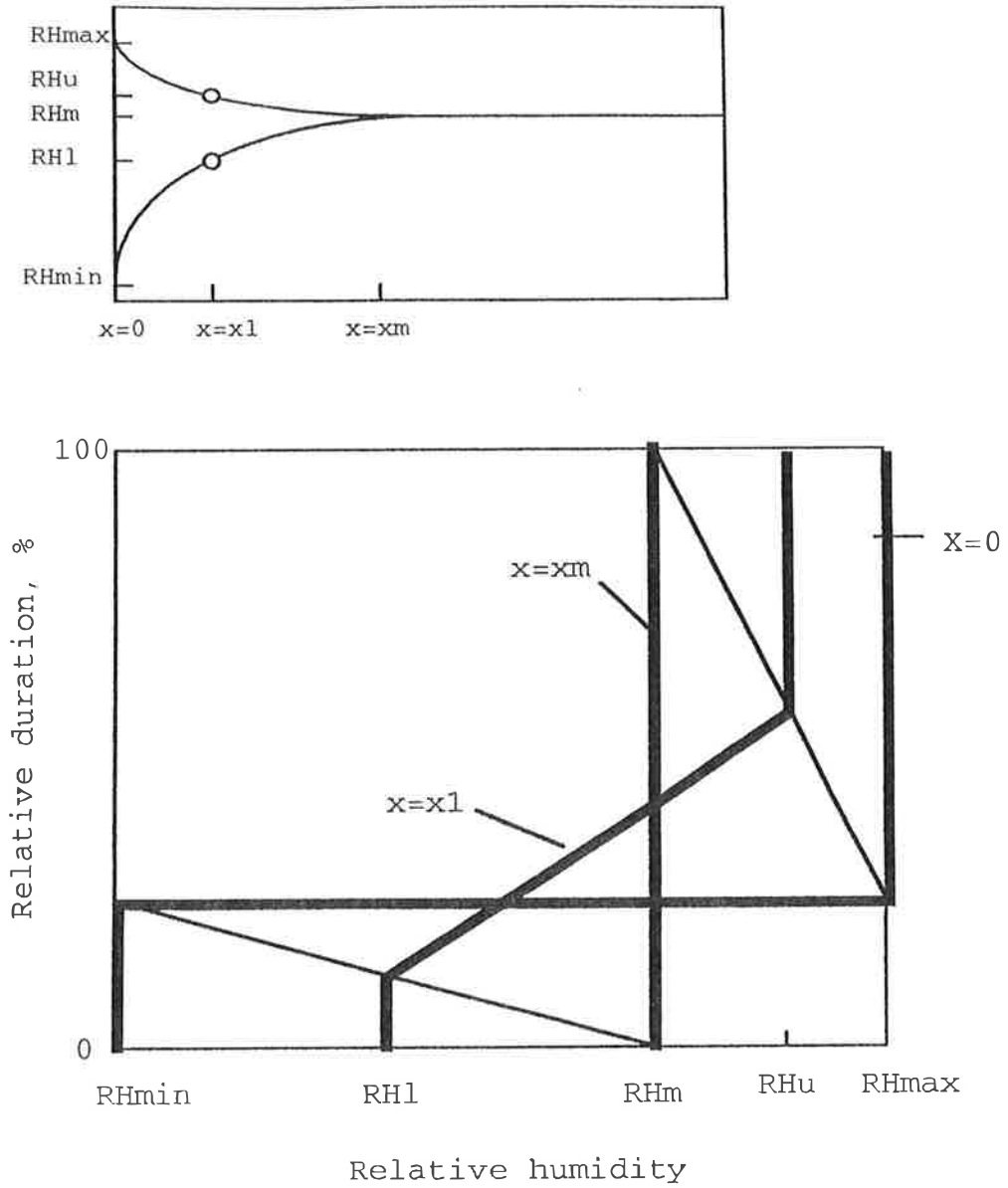

Fig 5.3: Approximative method to estimate the duration of a certain RH at a certain depth from the surface based on the limiting RH-curves calculated according to the method described in paragraph 6 and presented in APPENDICI 1 and 2.

6. Calculated examples

6.1 New calculations (in APPENDIX 1)

The upper, lower and average moisture levels expressed in terms of RH, as function of the depth from the concrete surface have been calculated. All results are shown in APPENDIX 1.

The outer moisture cycles regarded are shown in Fig 6.1. All cycles are supposed to be step-shaped and contain all combinations of 3 different durations of the upper and lower RH; viz. 1, 2, 4 weeks.

Other durations can be easily regarded by simply changing the scale of the x-axis according to the principles described in APPENDIX 1. So for example the effect of a regular wave splash on the moisture condition in the surface of a column above water can be estimated by the moisture profile for the case with 1 week of RH 100 % and 4 weeks of RH 60 %. If the time space between each splash period is 1 hour and the duration of the splash period is 0,2 hours (20 % of the total cycle) the solution of example 1B5 (w/c=0,4) or 1B12 (w/c=0,6) in the APPENDIX 1 can be used with the scale of the x-axis multiplied by a factor $\sqrt{0,2 / 7 \cdot 24} = 0,04$. Thus, the profile ("the moisture funnel") is moved towards the surface.

(In many cases, an even better estimation is possibly obtained by using the solutions in APPENDIX 2 for the case where the time of RH 100 % is 6 hours and the time of RH 80 % or 60 % is 7 days. This corresponds to a relative duration of wet and dry periods of 1 %. The profiles in the solutions in APPENDIX 2 should be then be moved towards the surface by a scale factor $\sqrt{100}=10$).

Two upper RH levels are used in the calculations:

- * $RH_{\max} = 95$ % representing a high outer moisture level but no free water against the surface.
- * $RH_{\max} = 100$ % representing an unlimited amount of free water against the surface.

Only one lower RH level is regarded:

- * $RH_{\min} = 60$ % representing a sort of average RH over the year. It might be a bit too high. The effect on the calculated moisture profile is probably marginal since the average moisture content is for the most part depending on the upper RH-level. In paragraph 6.2 and APPENDIX 2 some examples of the effect of an increase in the lower RH from 60% to 80 % are shown.

Other moisture levels can be easily introduced in the computer programme.

Only one temperature level is regarded; +20 °C. The effect of other temperatures is easily estimated by changing the scale of the x-axis for the actual "moisture funnel". The method is de-

scribed in APPENDIX 1. For example, if the temperature is 30 °C instead of +20 °C the scale of the x-axis is changed by the factor $\sqrt{1,29}=1,14$ (1,29 is the factor by which the moisture diffusivity is increased when the temperature increases from +20 °C to +30 °C; see paragraph 3.2).

The two calculated limiting moisture profiles converge at the average value RH_m on a certain depth x_m from the surface. Below this depth the concrete does not "feel" the outer climate variations. For the lowest w/c-ratios exposed to free water this depth is less well-defined. The reason is that the sorption isotherm is regarded to be horizontal at its upper part; see Fig A.6 in APPENDIX 1.

The convergence is supposed to occur on a depth where the variation in RH is only ± 1 % in RH when the upper RH is 95 % and ± 2 % in RH when the upper RH is 100 %.

The convergence depth and the mean value of RH at this depth are shown in Tables 6.1 and 6.2.

In the tables are also shown the depth on which the max or min value of RH is 90 %. Two cases are imaginable; see Fig 6.2.

- * **Case 1:** The concrete is on the convergence depth always wetter than RH 90 %. Then the depth where RH =90 % is called $x > 90$ %.
- * **Case 2:** The concrete is on the convergence depth always drier than RH 90 %. Then the depth where RH = 90 % is called $x < 90$ %

RH 90 % has been chosen since it signifies a value where the diffusion of gases is fairly low at the same time as the electrical resistivity is fairly high. Therefore the rate of reinforcement corrosion is often not so high at RH 90 %. In many cases, however, RH 80 % is a better limit. Similar analyses as that made for RH 90 % can, however, just as easily be made for RH 80 % and for other values of RH.

The following observations are made:

- 1: The mean value of RH in the concrete is higher than the average value of the outer RH. This is an effect of the unlinear moisture capacity of concrete disclosing itself by the unlinear sorption isotherms.
- 2: The mean value of RH in the concrete increases with increasing duration of the high RH-level outside the concrete.
- 3: The mean value of RH in the concrete increases with increasing outer RH. When the concrete is exposed to free water during 7 days or more, the relative humidity in the interior of the concrete (even at the depth of the reinforcement bars) is always very high.
- 4: The mean value of RH in the concrete on a large depth from the surface is almost independent of the w/c-ratio and only dependent of the outer moisture conditions.

Table 6.1: The mean value of RH in the interior of the concrete and the depth where almost no moisture variations occur. The upper RH-level in outside air is 95 %. Data from APPENDIX 1.

w/c	Duration (weeks)		RH _m (%)	Depth (mm)		
	Low RH (60%)	High RH (95%)		x _m	x _{>90%}	x _{<90%}
0,4	1	1	92	15	13	-
	1	2	94	17	10	-
	1	4	95	17	9	-
	2	1	87	18	10	-
	2	2	92	20	15	-
	2	4	94	25	14	-
	4	1	80	22	-	7
	4	2	87	25	-	15
	4	4	92	28	23	-
0,5	1	1	90	20	-	-
	1	2	92	18	15	-
	1	4	94	16	10	-
	2	1	86	23	-	12
	2	2	90	28	-	-
	2	4	92	28	20	-
	4	1	81	26	-	10
	4	2	86	33	-	20
	4	4	90	40	-	-
0,6	1	1	90	18	-	-
	1	2	93	19	13	-
	1	4	94	19	12	-
	2	1	86	19	-	12
	2	2	90	25	-	-
	2	4	93	28	17	-
	4	1	81	23	-	6
	4	2	86	28	-	15
	4	4	90	37	-	-

Table 6.2: The mean value of RH in the interior of the concrete and the depth where almost no moisture variations occur. The concrete is regularly exposed to free water (the upper RH-level is 100 %). Data from APPENDIX 1.

w/c	Duration (weeks)		RH _m (%)	x _m	Depth (mm)	
	Low RH (60)	High RH (100%)			x _{>90%}	x _{<90%}
0,4	1	1	98	45	8	-
	1	2	98	45	7	-
	1	4	99	45	7	-
	2	1	96	45	11	-
	2	2	97	55	10	-
	2	4	98	65	10	-
	4	1	95	45	15	-
	4	2	96	70	15	-
	4	4	97	80	15	-
0,6	1	1	99	20	5	-
	1	2	99	20	5	-
	1	4	100	20	5	-
	2	1	98	25	6	-
	2	2	99	25	6	-
	2	4	100	25	6	-
	4	1	98	30	10	-
	4	2	98	35	10	-
	4	4	99	35	10	-

6.2 Previous calculations (in APPENDIX 2)

Calculations of the similar type have been performed previously /10/. Then, some other outer moisture variations were also investigated; especially the effect of short periods of rain or other types of free water. The variations in the outer moisture conditions are shown in Fig 6.3. The material data are the same as in the new calculations presented in APPENDIX 1.

The variables are shown in Table 6.3 together with the mean value of RH on a large depth from the surface (RH_m) and the depth on which the RH variation is below ±1% (x_m). In the tables are also shown the depth on which RH is 90 %. It is defined in Fig 6.2.

The following interesting observations are made:

- 1: At short exposures to free water followed by rather long drying periods the interior of a concrete with the w/c-ratio 0,4 stays well below RH 90 %.
- 2: At the same short wet periods the interior of a concrete with the w/c-ratio 0,6 is well above RH 90 %. Thus, free water is sucked to a much greater depth when the w/c-ratio is increased.
- 3: When drying occurs at RH 80% the average humidity, RH_m , in the concrete with the w/c-ratio 0,4 is much higher than in the case where drying occurs at RH 60 %. For a concrete with the w/c-ratio 0,6 on the other hand, the drying climate is of little importance; RH_m will be just as high when drying occurred at RH 60 % as when it occurred at RH 80.

Table 6.3: The mean value of RH in the interior of the concrete and the depth where almost no moisture variations occur.
The upper RH level is regularly exposed to free water (RH 100 %). Data from APPENDIX 2

w/c	Duration		RH_m	x_m	Depth (mm)	
	low RH-level 60%	high RH-level 100%			$x_{>90\%}$	$x_{<90\%}$
0,4	7 days	6 hours	76	9	-	3
		7 days	87	7	-	6
	30 days	24 hours	75	18	-	7
		7 days	97	28 ¹⁾	5	-
0,6	7 days	6 hours	96	17	6	-
		7 days	96	15	3	-
	30 days	24 hours	96	32	13	-
		7 days	99	5 ¹⁾	2	-

1) Depth where the RH-variation is ± 2 % in RH.

a) Duration of the lowest RH is 1 week

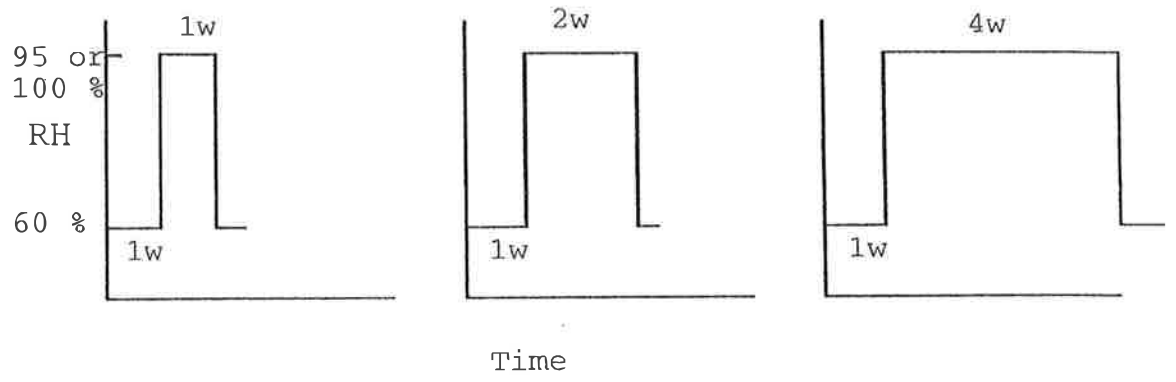

b) Duration of the lowest RH is 2 week

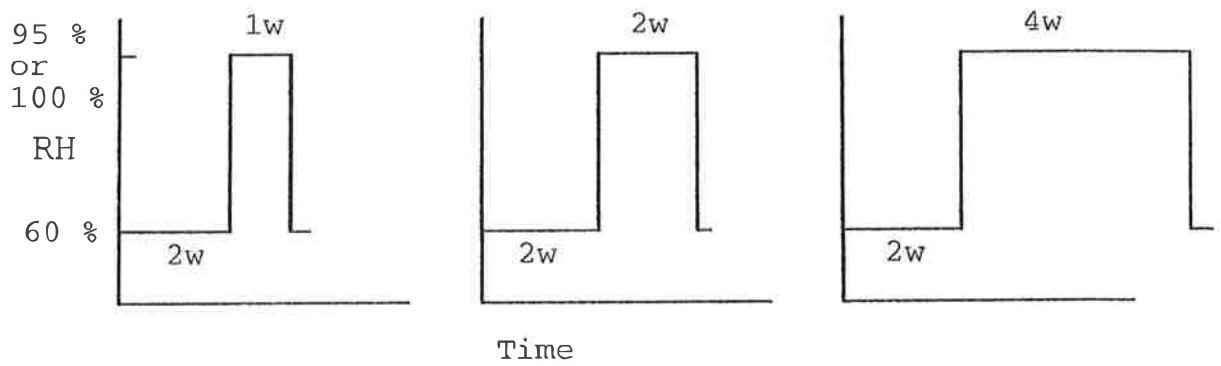

c) Duration of the lowest RH is 4 weeks

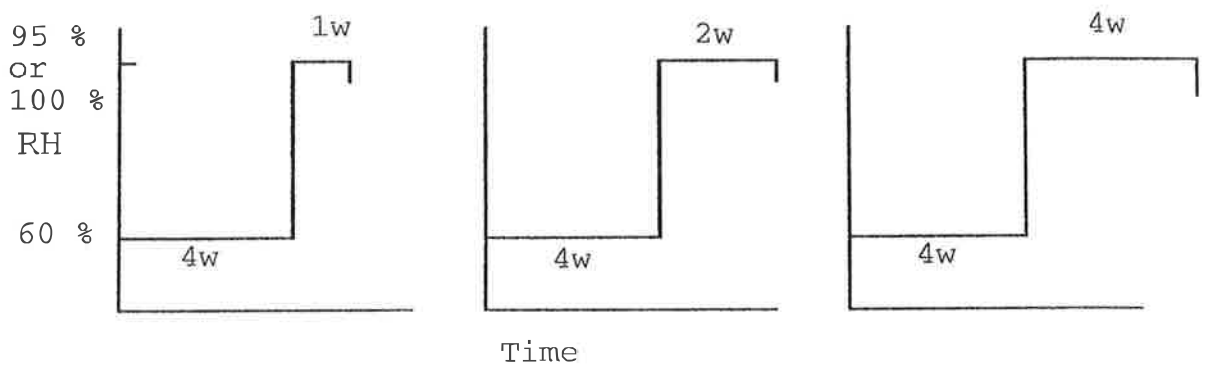
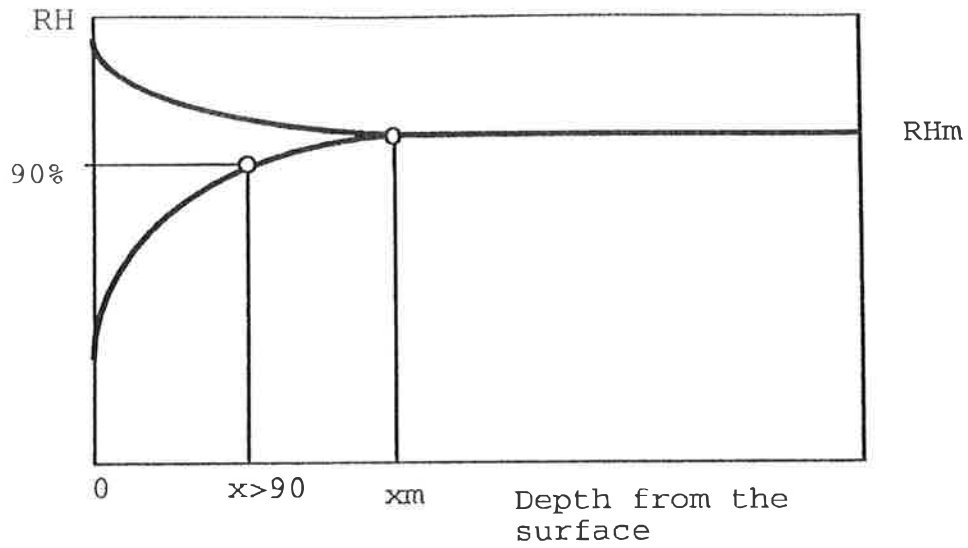

Fig 6.1: The moisture cycles used in the calculations in paragraph 6.1 and APPENDIX 1.

Case 1: The interior is wetter
than RH 90 %



Case 2: The interior is drier
than RH 90 %

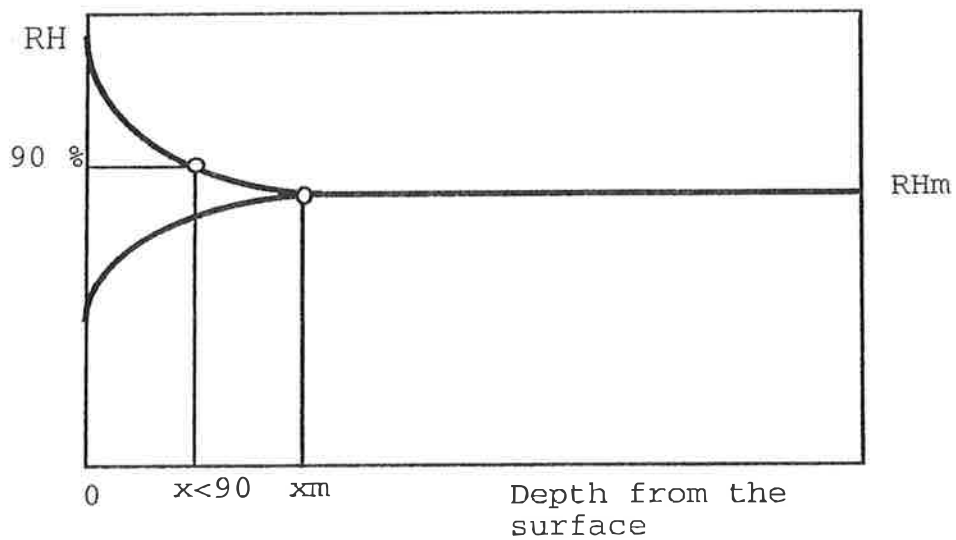
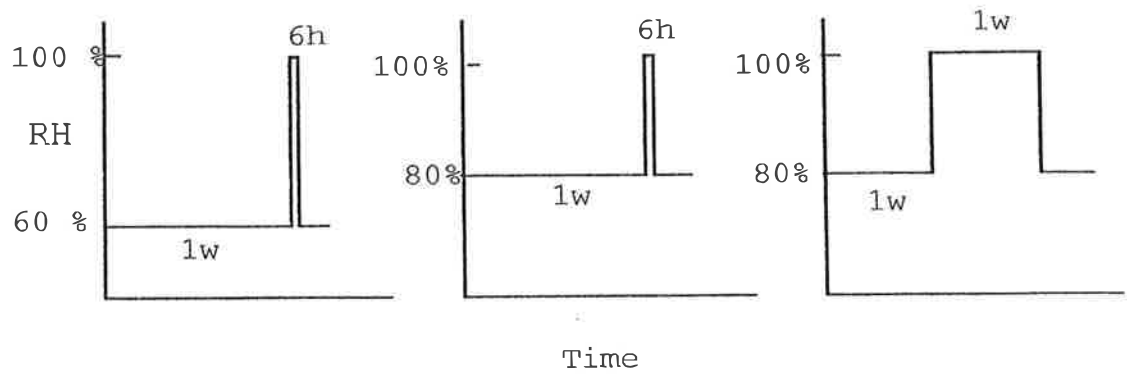

Fig 6.2: Definition of the depth $x_{>90\%}$ and $x_{<90\%}$ used in Tables 6.1, 6.2 and 6.3.

a) Duration of the lowest RH is 1 week



b) Duration of the lowest RH is 30 days

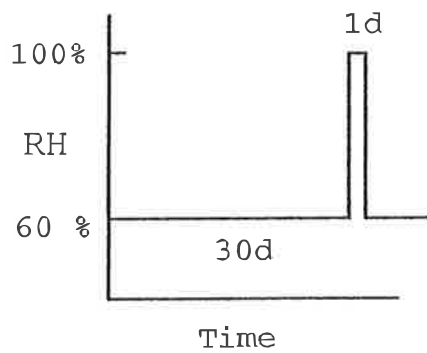

Fig 6.3: The moisture cycles used in the calculations in paragraph 6.2 and in APPENDIX 2.

7. Further development and computer calculations

The computer programme will be developed further so that the duration of different RH-levels on a certain depth from the surface can be obtained. An attempt will thereafter be made to introduce the diffusion of a gas like CO₂ or O₂ or an ion like chloride. This would make it possible to calculate the effect of the outer climate conditions on the time it takes to start corrosion and to calculate the corrosion rate.

The programme will be designed in such a way that individual data for the diffusivity of moisture, gas and ions can be introduced as well as individual data for the outer climate variations.

References

- /1/ T.C.Powers, T.L.Brownyard: Studies of the physical properties of hardened portland cement paste. Res Lab of the PCA, Bull 22 , Chicago 1948.
- /2/ L-O. Nilsson: Hygroscopic moisture in concrete - Drying, measurements & related properties. Div of Building Materials, Lund Institute of Technology, Report TVBM-1003 , Lund, 1980. (Doctor thesis).
- /3/ E.J. Sellevold, D.H.Bager, E.Klitgaard Jensen, T.Knudsen: Hydration and pore structure. Paper in "Condensed Silica Fume in Concrete". Div of Building Materials, The Norwegian Institute of Technology, NTH. Report BML 82.610, Trondheim, 1982.
- /4/ A. Xu: Structure of hardened cement-fly ash systems and their related properties. Div of Building Materials, Chalmers University of Technology, Gothenburg 1992. (Doctor thesis).
- /5/ K.Tuutti: Corrosion of steel in concrete. Swedish Cement and Concrete Research Institute. Research Fo 4:82, Stockholm, 1982. (Doctor thesis).
- /6/ G.Fagerlund: The long time water absorption in the airpore structure of concrete. Contribution to BRITE/EURAM Project BREU-CT92-0591. Div of Building Materials, Lund Institute of Technology, Lund 1993.
- /7/ J Crank: The mathematics of diffusion. Clarendon Press, Oxford, 1985.
- /8/ G.Hedenblad: Moisture permeability of mature concrete, cement mortar and cement paste. Div of Building Materials, Lund Institute of Technology. Report TVBM-1014 (a doctor thesis), Lund 1993. (Doctor thesis).
- /9/ J.Arvidsson: Computer models for moisture flow in porous media. Div. of Building Physics, Lund Institute of Technology. Report TVBH-7108, Lund 1988.
- /10/ J.Arvidsson, G Hedenblad: Calculations of moisture penetration depth in concrete. Div of Building Materials , Lund Institute of Technology. Report U91.06, Lund 1991.

APPENDIX 1

NEW COMPUTER CALCULATION OF THE MOISTURE-TIME FIELD IN CONCRETE

Göran Hedenblad

A.1 Introduction

This report presents a method to calculate the depth of moisture variations in the outer part of concrete exposed to cyclic boundary conditions (relative humidity, RH). The method is based on results from measurements of the moisture permeability of different concrete qualities. At first the method to measure and evaluate material data is presented and then a short description of the calculation method is given followed by some examples.

A.2 Material data

By using a method which relies on the measurement of the water vapour flow from a specimen and the distribution of the relative humidity in the specimen, under stationary conditions, the moisture permeability can be calculated, and its dependence on RH can be determined, Hedenblad /1993/. The data below are taken from this report..

A.2.1 Experimental arrangement

The experimental arrangement is shown in principle in FIG A.1. The flow of water is unidirectional and goes from the bottom to the top of the specimen.

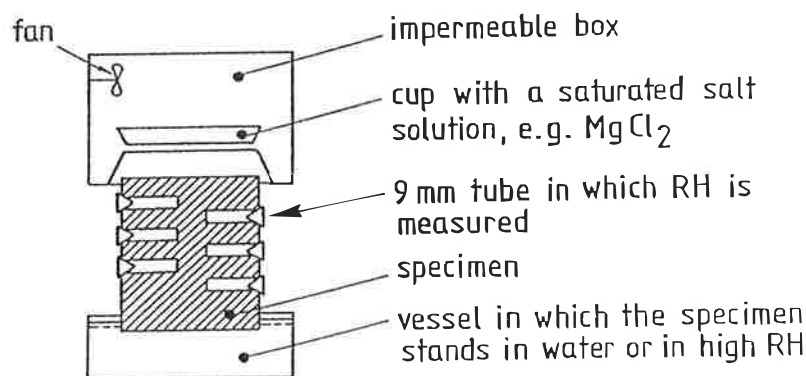

FIG A.1 The experimental arrangement in principle.

The upper part of the experimental arrangement consists of a practically impermeable box in which RH is held constant by means of a saturated salt solution in a cup; in our case magnesium chloride, $MgCl_2$, for which RH is about 33 %. The cup is weighed regularly, every week, to obtain the flow from the specimen. The top surface of the specimen is exposed to the air inside the box. A small fan circulates the air inside the box. The bottom surface of the specimen is 0.2×0.2 m. The heights of the specimens are 0.063, 0.100 and 0.150 m.

The surfaces of the specimen exposed to the surrounding air in the room are sealed with 2 mm

almost impermeable epoxy resin. The bottom surface of the specimen stands in water or in air with high RH, which is effected by a water surface about 2 to 3 centimetres below the specimen.

Plastic tubes of about 14 mm external and about 9 mm internal diameters are embedded in the sides of the specimen. The internal end surface of the tubes is open towards the specimen, and RH in the tubes is in equilibrium with RH in the specimen. The tubes are used for measuring the RH-profile through the specimen.

The results, which are used in this report, derive from specimens with a height of 0.100 m.

A.2.2 Tested materials

The following test program concerning different compositions of concrete was carried out

- OPC-concrete with water-cement ratio (w_0/C) 0.4, 0.5, 0.6, 0.7 and 0.8
- OPC-concrete with $w_0/C = 0.7$ with different amounts of aggregate
- OPC-concrete with $w_0/C = 0.7$ with different amounts of air.

Compositions of concrete with different w_0/C are shown in TABLE A.1. The crushed stone, 8 - 18 mm, consists of quartzite.

TABLE A.1. Composition of concrete with different w_0/C .

w_0/C	Cement, C (kg/m^3)	Water, w_0 (kg/m^3)	Sand/Gravel (kg/m^3)	Crushed stone 8 - 18 mm (kg/m^3)
0.4	418	167.2	990	810
0.5	368	184.0	990	810
0.6	328	196.8	990	810
0.7	296	207.2	990	810
0.8	270	216.0	990	810

A.2.3 Some results

The distribution of the relative humidity for specimens with $w_0/C = 0.6$ is shown in FIG A.2 and FIG A.3.

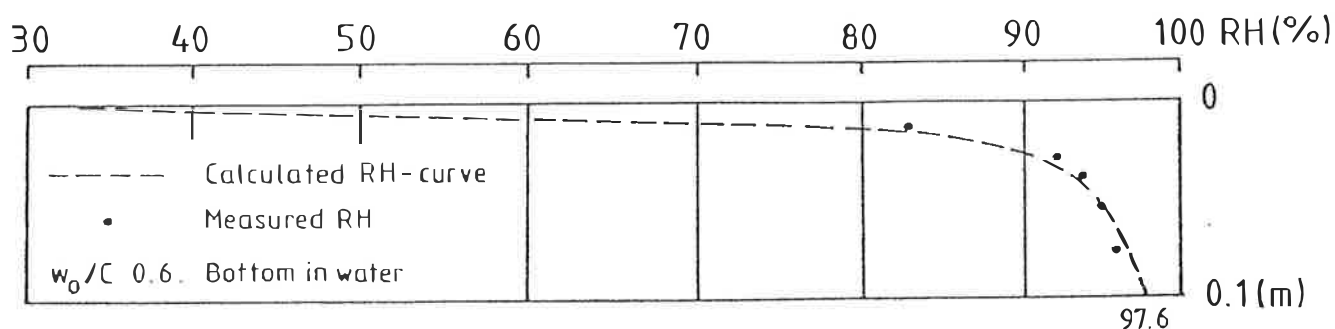

FIG A.2 Distribution, at equilibrium, of the relative humidity in concrete specimens with a height of 0.100 m. Water-cement ratio 0.6. The bottom surface in water.

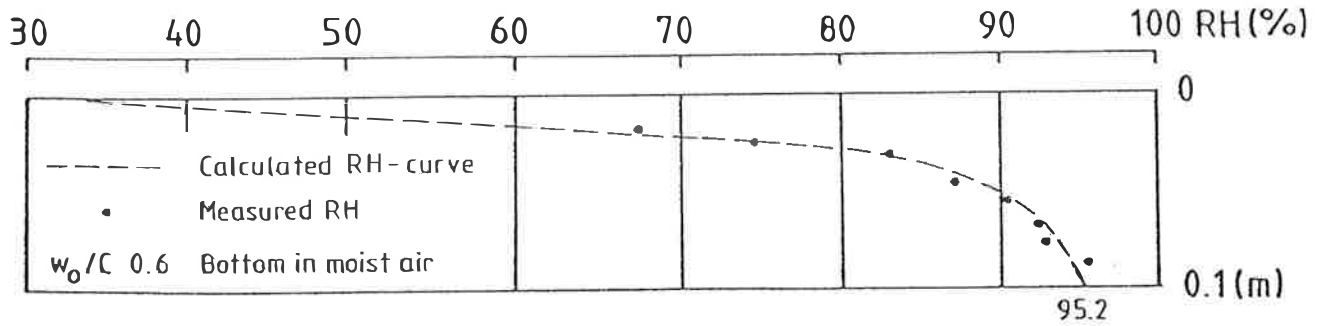

FIG A.3 Distribution, at equilibrium, of the relative humidity in concrete specimens with a height of 0.100 m. Water-cement ratio 0.6. The bottom surface in moist air.

It is seen that RH in the specimens is not 100 % even if the specimens stand in water. One obvious explanation is that the pore water contains salts, mainly alkali, and the salt lowers the maximum RH to a value below 100 %.

A.2.4 Capillary transport

To get transport data for capillary suction, concrete specimens have been dried at room temperature to about 60 % RH. The specimens have then been allowed to suck water and the weight increase has been registered. FIG A.4 shows the results when the capillary transport has been described as a diffusion process with a high value of the moisture permeability (δ_v). The moisture permeability (δ_v) has the humidity by volume in the pores of the material as potential.

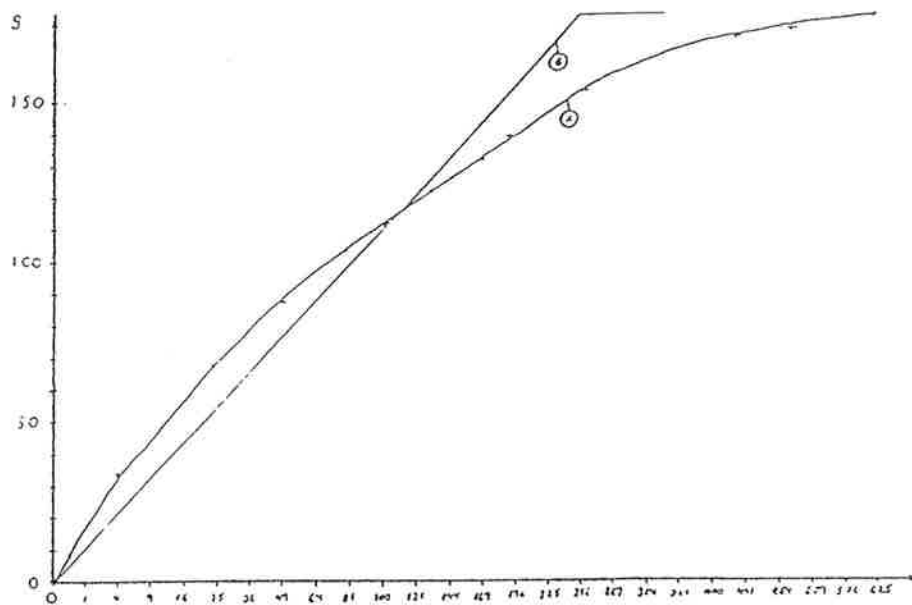

FIG A.4 Measured (A) and calculated (B) capillary transport in concrete. w_0/C 0.6.

Curve A shows the measured increase of weight for concrete with $w_0/C = 0.6$. Curve B shows the calculated increase of weight using a diffusion coefficient that is 15 times as big as the

maximum moisture permeability obtained in the test described in Section A.2.3. For concrete with $w_0/C = 0.4$ preliminary results from measurements and calculations show that the maximum moisture permeability has to be increased with a factor 20 to describe the capillary transport in a fair way.

Fig A.5 shows the moisture permeability for concrete with $w_0/C = 0.6$. The solid line shows the result from diffusion measurements (see Section A.2.1) and the dotted line shows the approximated values of δ_v , made from the capillary measurements.

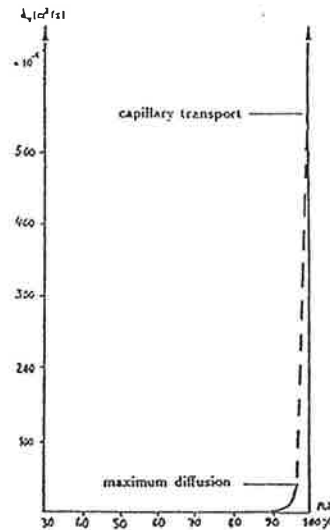

FIG A.5 The moisture permeability (δ_v) for concrete $w_0/C = 0.6$ in the diffusion area below 95 % RH (solid line) and approximated values of δ_v in the upper diffusion and the capillary suction area (dotted line).

A.2.5 Desorption isotherms

Nilsson /1980/ has published desorption isotherms for cement paste with different w_0/C . The isotherms go up to 100 % RH. Some revisions of the isotherms have been made by Hedenblad /1988/, so that the alkalis in the cement determine the maximum RH (lower than 100 %). FIG A.6 shows these revised desorption isotherms.

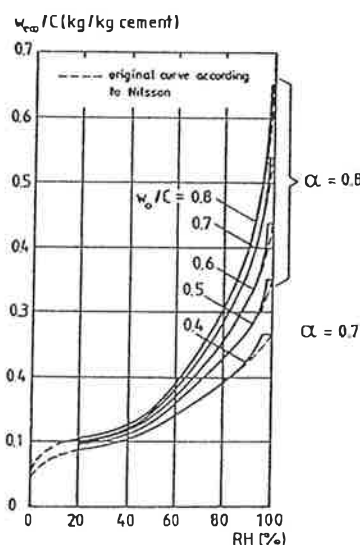

FIG A.6 Desorption isotherms for cement paste with different w_0/C and degrees of hydration. Based on isotherms according to Nilsson /1980/, revised by Hedenblad /1988/.

A.3 Calculation method

A.3.1 Fundamental flow potential

The numerical calculations use the fundamental flow potential instead of ordinary potentials. Let g ($\text{kg H}_2\text{O}/\text{m}^2\text{s}$) denote the moisture flow and ξ any moisture flow potential. In the one-dimensional case we have, when temperature effects and hysteresis are neglected

$$g = D_\xi(\xi) \partial \xi / \partial x \quad (\text{A.1})$$

Here ξ may denote, for example, the relative humidity ϕ , the vapour pressure p (Pa), the humidity by volume v (kg/m^3) or the moisture content by volume w (kg/m^3 material).

The fundamental flow potential, when the flow coefficient D_ξ is a function of the state, was originally introduced by Kirchoff ; see Carslaw et al /1959/. This potential is defined by

$$\Psi = \int D_\xi(\xi) \partial \xi \quad (\text{A.2})$$

The potential Ψ is the area under the curve between ξ_{ref} and ξ , see FIG A.7 (showing the case $\xi = v$). It becomes a function for each material; $\Psi = \Psi(\xi)$.

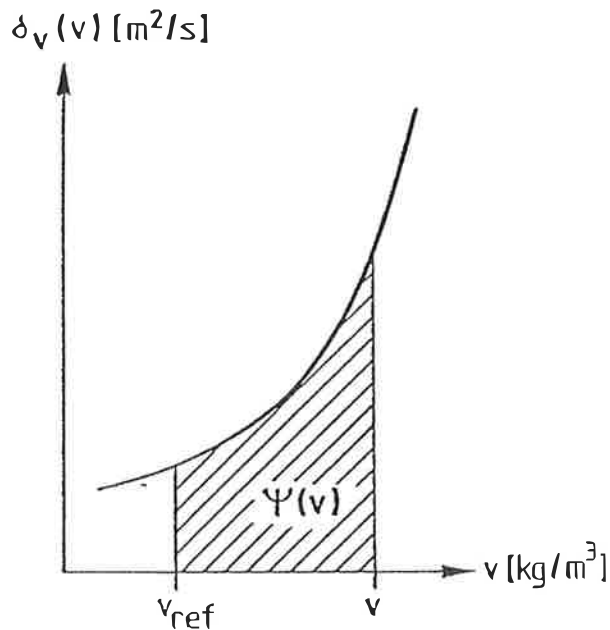

FIG A.7 The flow potential Ψ is the area under the curve $D_v(v)$.

The flow potential Ψ is independent of which of the various flow potentials (ξ) and ensuring coefficient function $D_\xi(\xi)$ that is used. The reference value ξ_{ref} can be chosen arbitrarily for each material. The value of Ψ is always set to zero for the reference level, ξ_{ref} , for the particular material $\Psi(\xi_{\text{ref}}) = \Psi_{\text{ref}} = 0$. $D_v =$ the moisture permeability δ_v .

In a conventional numerical simulation the flows between nodes are obtained by a discrete approximation of Eq.(A.1). A big problem is, when $D_\xi(\xi)$ varies strongly between the nodes. One must interpolate or, what is better, solve Eq.(A.1) locally between the nodes. With the fundamental flow potential an exact calculation between two nodes gives the flux from the difference in Ψ between these nodes.

A.4 Calculations performed

Calculations have been made to obtain the relative humidity distribution, and the depth from the surface where the moisture conditions are constant. Different qualities of concrete during different cyclic boundary conditions have been studied. The cycles are stepped and varies cyclic from a constant low RH which is always 60 % to another constant high RH which is either 95 % or 100 %. The variations are seen in FIG 6.1. The calculations are made with a PC-program called JAM-P, specially developed for this kind of calculations. In the examples it is assumed that the constructions have been exposed for the given boundary conditions during long time, so that the relative humidity level has become stable deep inside the construction. In the examples 100 % relative humidity means rain and capillary transport. The variables calculated are shown in TABLES A.2 and A.3.

TABLE A.2 The construction is not exposed to direct rain.
Low RH= 60 %. High RH=95 %.

w_0/c	Duration (week)		Littera of calculation example
	low RH	high RH	
0.4	1	1	1A1
		2	1A4
		4	1A5
	2	1	1A6
		2	1A2
		4	1A9
	4	1	1A7
		2	1A8
		4	1A3
0.5	1	1	1A10
		2	1A13
		4	1A14
	2	1	1A15
		2	1A11
		4	1A18
	4	1	1A16
		2	1A17
		4	1A12
0.6	1	1	1A19
		2	1A22
		4	1A23
	2	1	1A24
		2	1A20
		4	1A27
	4	1	1A25
		2	1A26
		4	1A21

TABLE A.3 The construction is exposed to rain.
Low RH=60 %. High RH=100 %.

w_0/C	Duration (weeks)		Littera of calculation example
	low RH	high RH	
0.4	1	1	1B1
		2	1B4
		4	1B5
	2	1	1B6
		2	1B2
		4	1B9
4	1	1B7	
	2	1B8	
	4	1B3	
0.6	1	1	1B10
		2	1B13
		4	1B14
	2	1	1B15
		2	1B11
		4	1B18
	4	1	1B16
		2	1B17
		4	1B12

A.4.1 Other times

From the calculated examples it is easy to calculate the penetration profiles and depths for other times when the boundary conditions in terms of the two RHs and the relation between the two times in the cycle are the same. For example; let us calculate the penetration depth for the case with 95 % RH during 2 days and 60 % RH during 2 days; $w_0/C = 0.6$. We can then use Example 1A19, 1A20 or 1A21 since they all have the same upper and lower RH and the same ratio -1:1- between the two times in the cycle. We use Example 1A21. The new penetration depth is $d_0 \sqrt{t/t_0}$, where t is the new time (period) and d_0 is the penetration depth according to Example 1A21.

A.4.2 Other temperatures

If it is supposed that the moisture permeability follows an "Arrhenius function" we have

$$\delta_{v1} / \delta_{v0} = \exp(E_a/R*(1/T_0 - 1/T_1)) \quad (\text{A.3})$$

E_a = activation energy of water transport

R = general gas constant

T = temperature

(18800 J/mole)

(8.314 J/mole*K)

(K)

The given examples are calculated for the temperature + 20 °C. With the above data $\delta_{v1} / \delta_{v0}$ is given in TABLE A.4.

TABLE A.4 $\delta_{v1} / \delta_{v20}$ as a function of temperature.

Temperature °C	+5	+10	+15	+20	+25	+30
$\delta_{v1} / \delta_{v20}$	0.66	0.76	0.87	1	1.14	1.29

With $\delta_{v1} / \delta_{v20}$ according to TABLE A.4 it is possible to calculate the new penetration depth at another temperature using the parameter $d_1 = d_{20} * \sqrt{(\delta_{v1} / \delta_{v20})}$.

References

- Carslaw, H.S. and Jaeger, J. C. (1959) *Conduction of Heat in Solids*, pp. 8-13, 2nd ed., Oxford University Press, Oxford.
- Hedenblad, G. (1988) *Effect of soluble salt on the sorption isotherm*, Lund Institute of Technology, Division of Building Materials, Lund, Report TVBM-3035.
- Hedenblad, G. (1993) *Moisture permeability of mature concrete, cement mortar and cement paste*, Lund, Institute of Technology, Division of Building Materials, Lund, Report TVBM-1014
- Nilsson, L-O. (1980) *Hygroscopic moisture in concrete - Drying, measurements and related material properties*. Lund Institute of Technology, Division of Building Materials, Lund, Report TVBM-1003.

A.5 Results of calculations

The results of the calculations are shown below. The step-wise cyclic variation is shown to the right of the figure. The black region is the RH-range within which the real RH varies at the actual depth from the surface. The mean RH in the concrete are shown in the figure. In some cases they are difficult to read. Therefore they are also listed in the report Tables 6.1 and 6.2

Numerical examples 1

$w/c=0,4.$

Not exposed to free water but to high RH

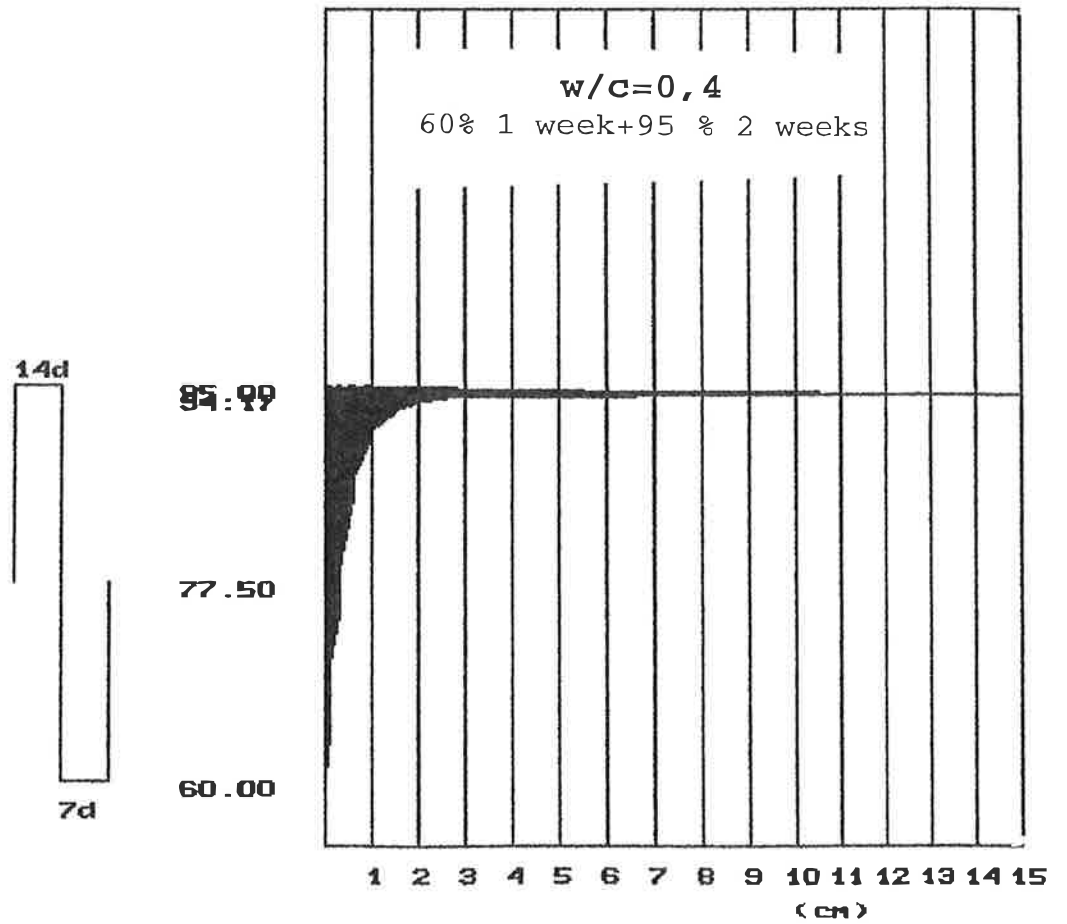
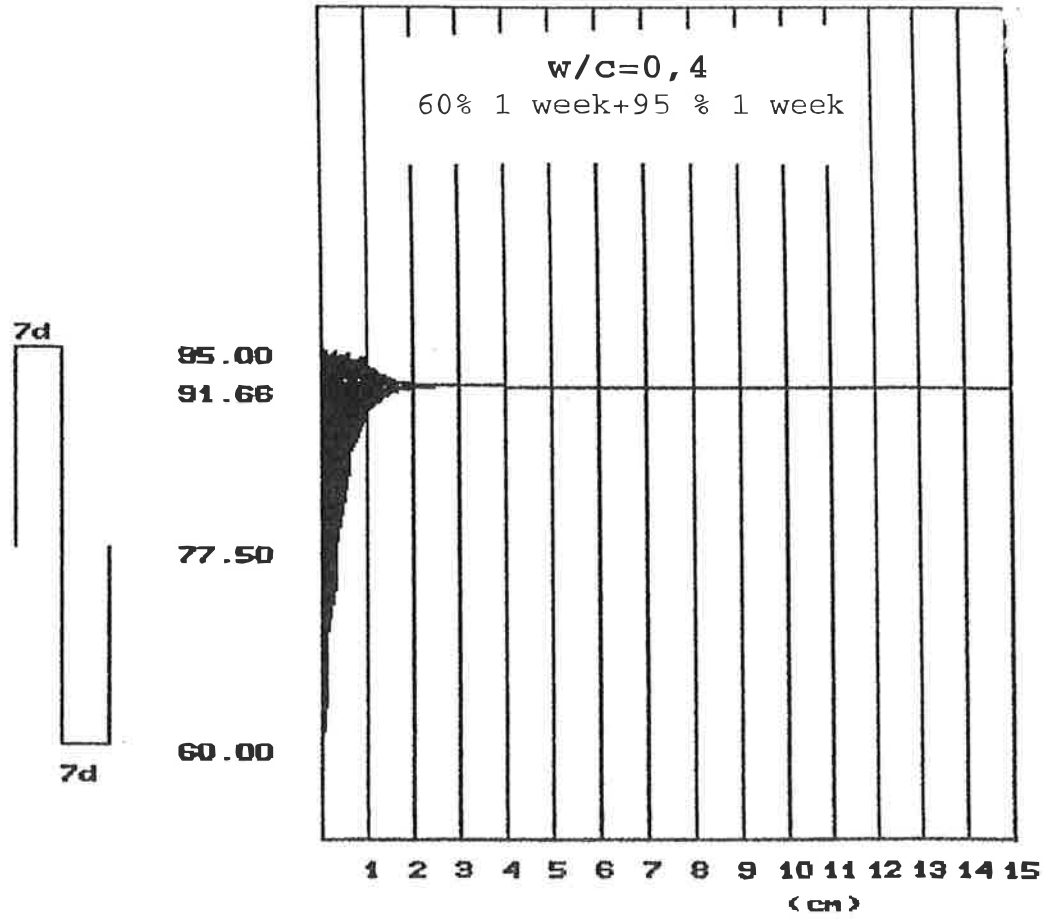

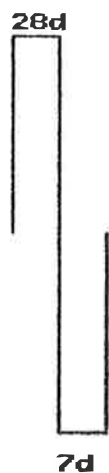

84.90
77.50
60.00

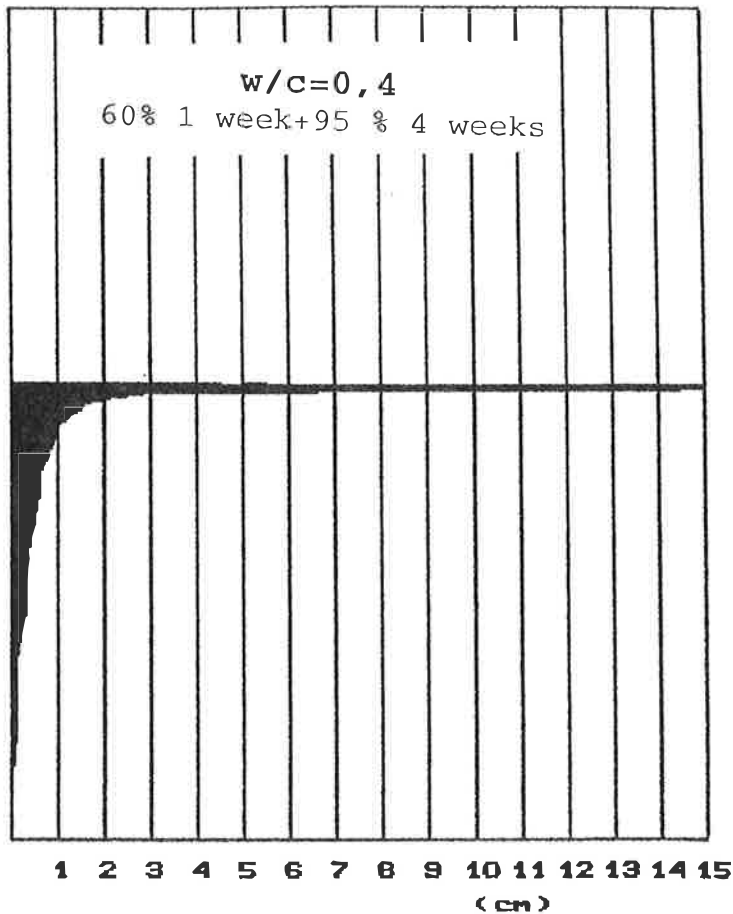

85.00
66.80
77.50
60.00

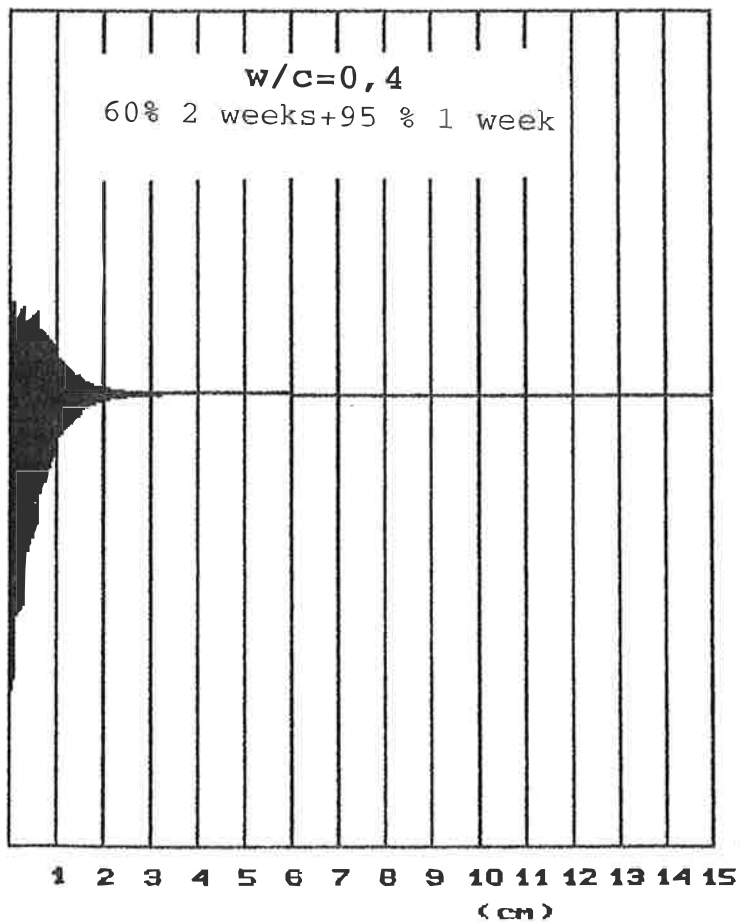

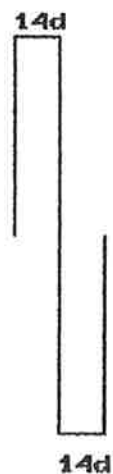

85.00
91.66
77.50
60.00

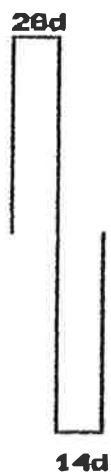
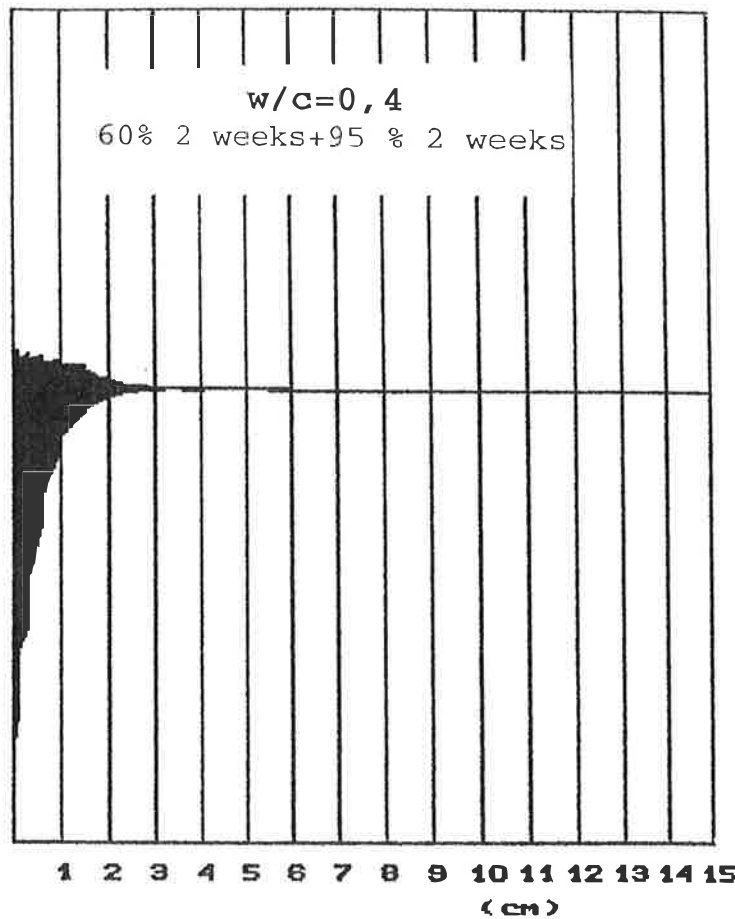

85.99
77.50
60.00

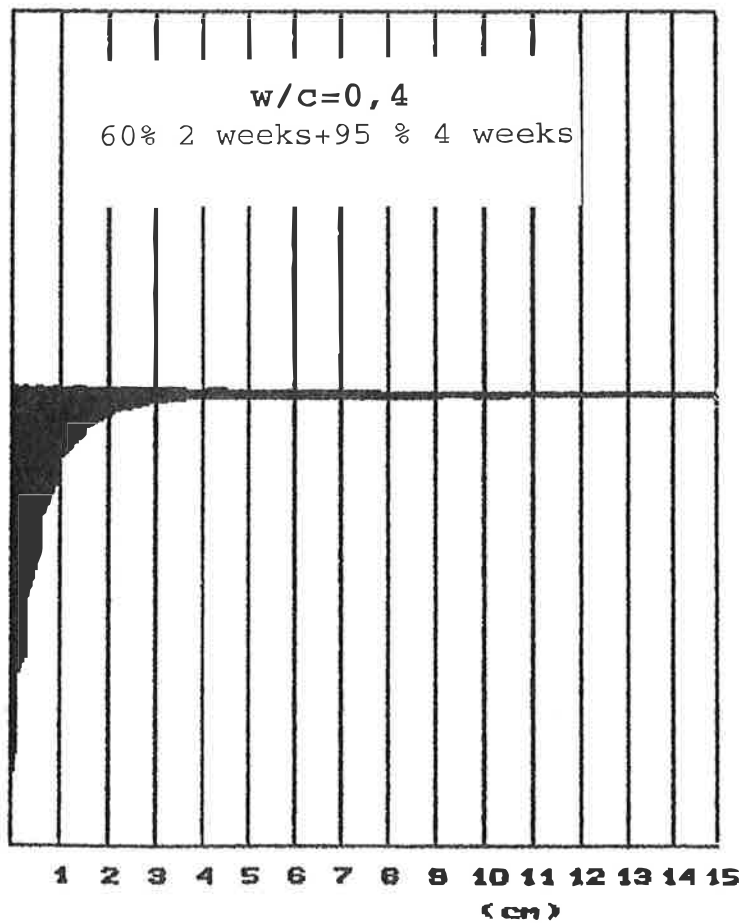

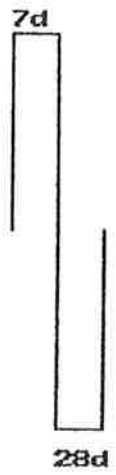

95.00
80.19
77.50
60.00

w/c=0,4
60% 4 weeks+95 % 1 week

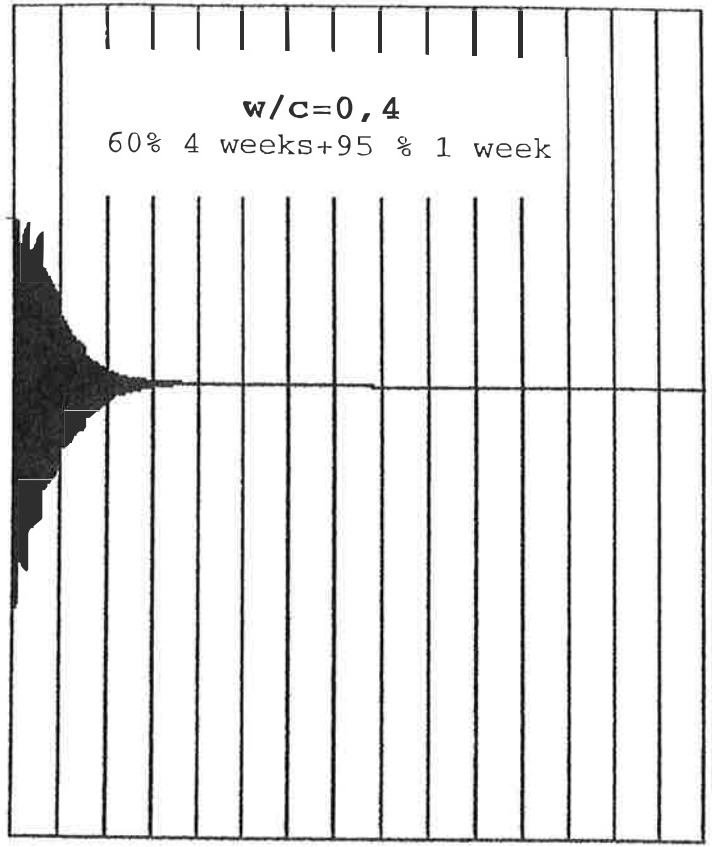

1 2 3 4 5 6 7 8 9 10 11 12 13 14 15
(cm)

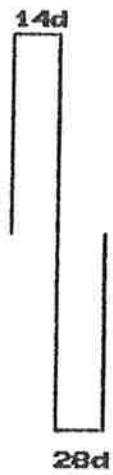

95.00
86.80
77.50
60.00

w/c=0,4
60% 4 weeks+95 % 2 weeks

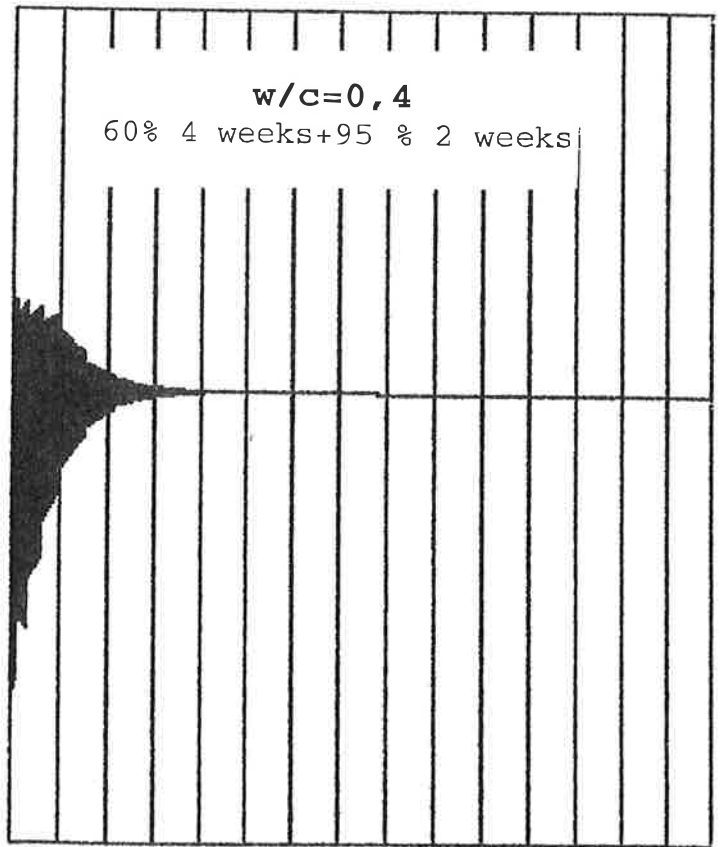

1 2 3 4 5 6 7 8 9 10 11 12 13 14 15
(cm)



85.00
91.66
77.50
60.00

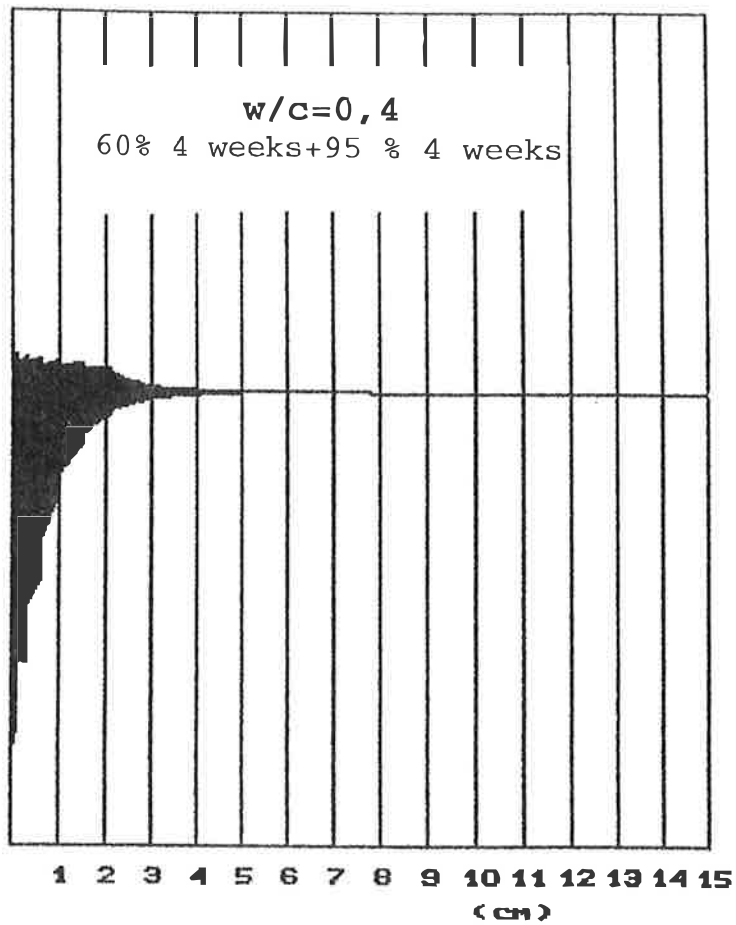

Numerical examples 2

$$w/c=0,5.$$

Not exposed to free water but to high RH

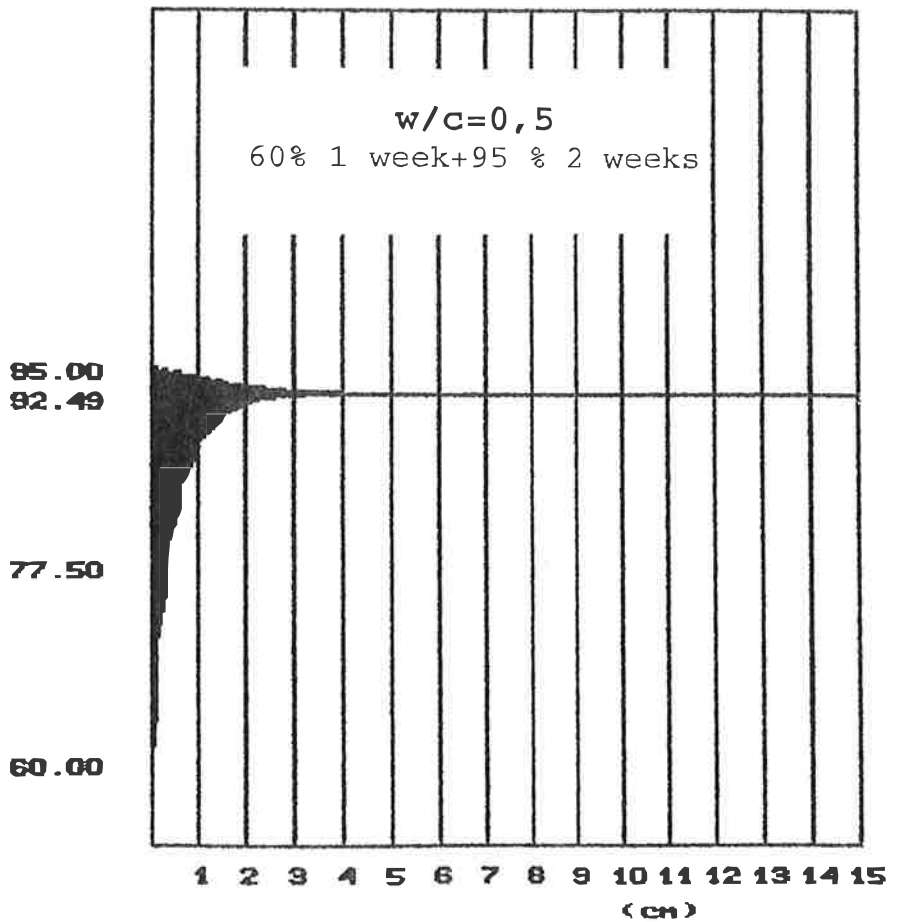
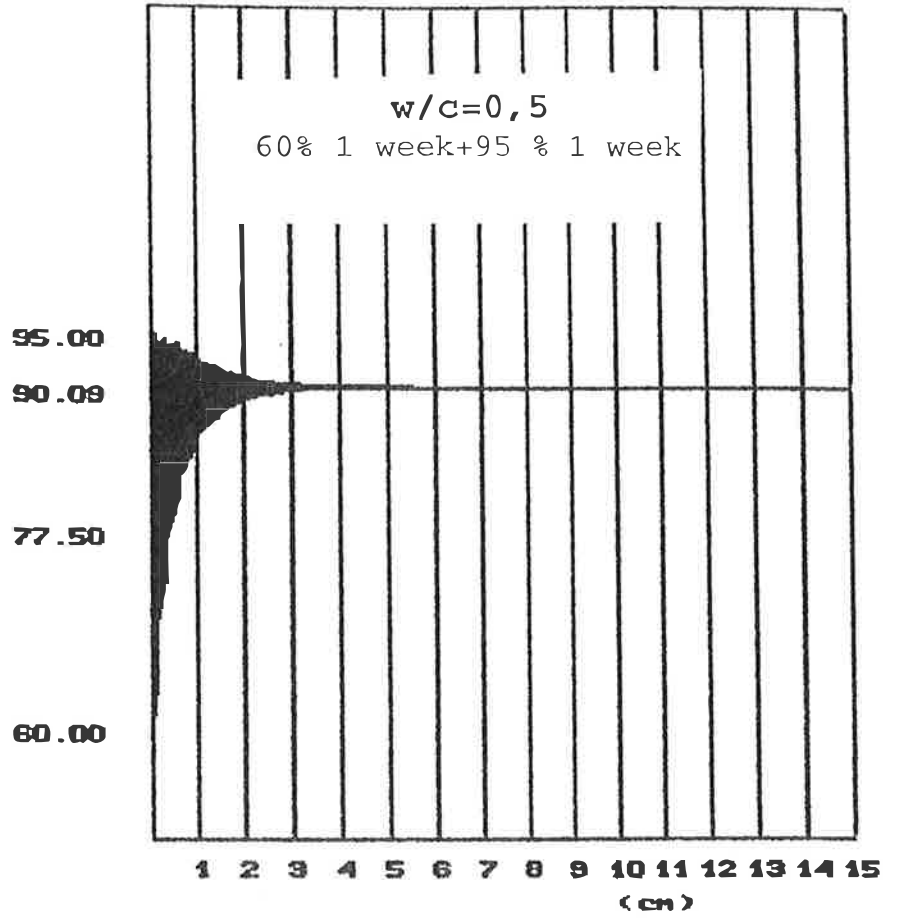



85.02
77.50
60.00

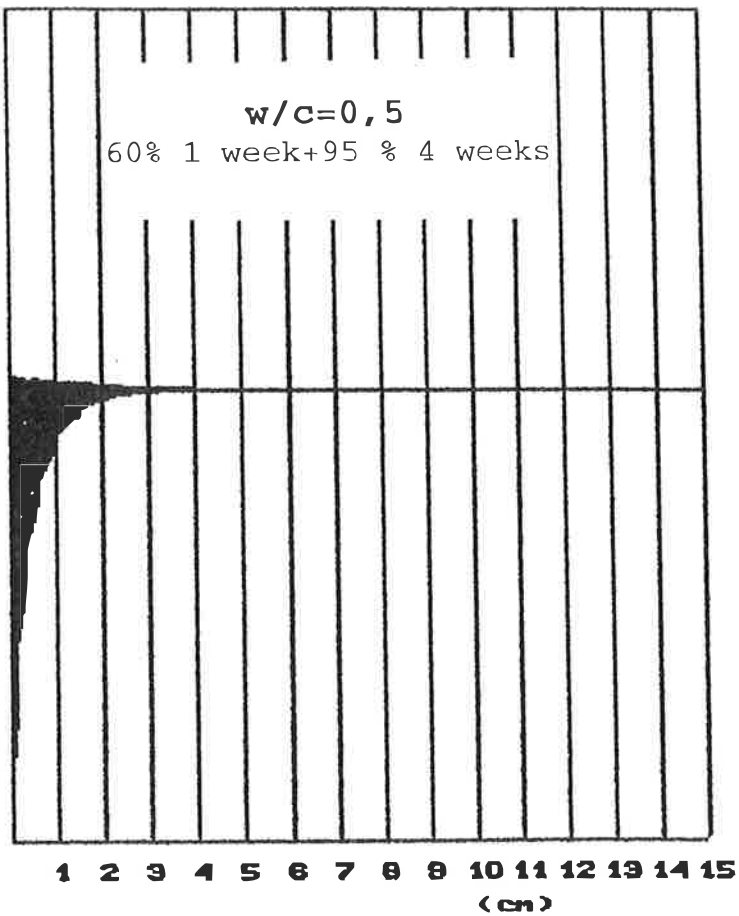

85.00
66.09
77.50
60.00

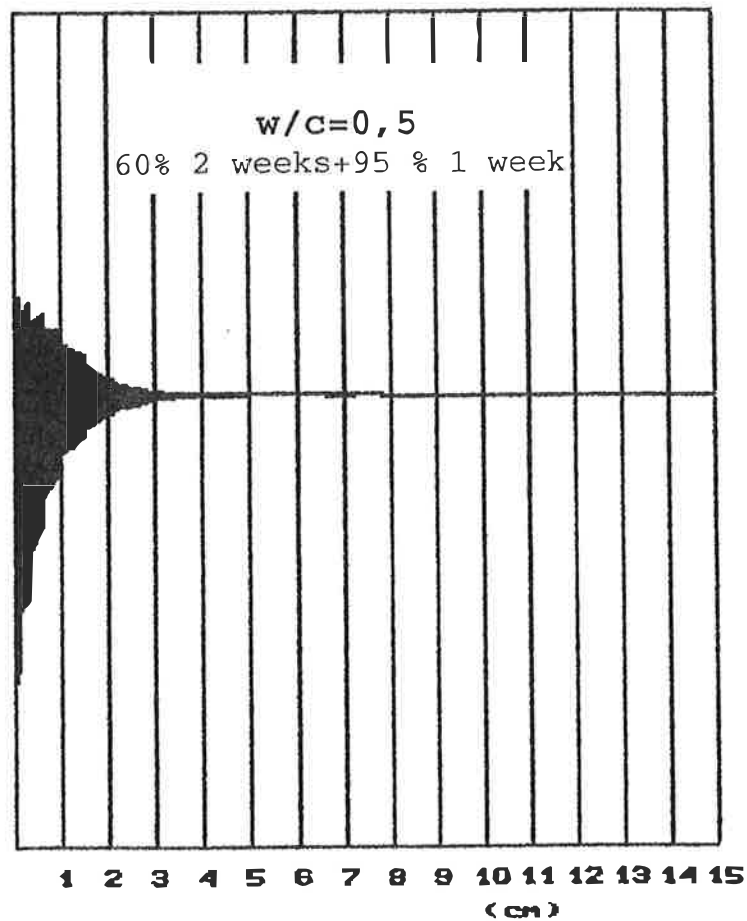

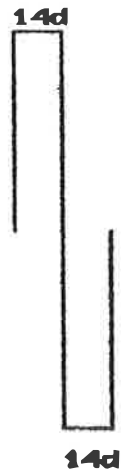

95.00
90.09
77.50
60.00

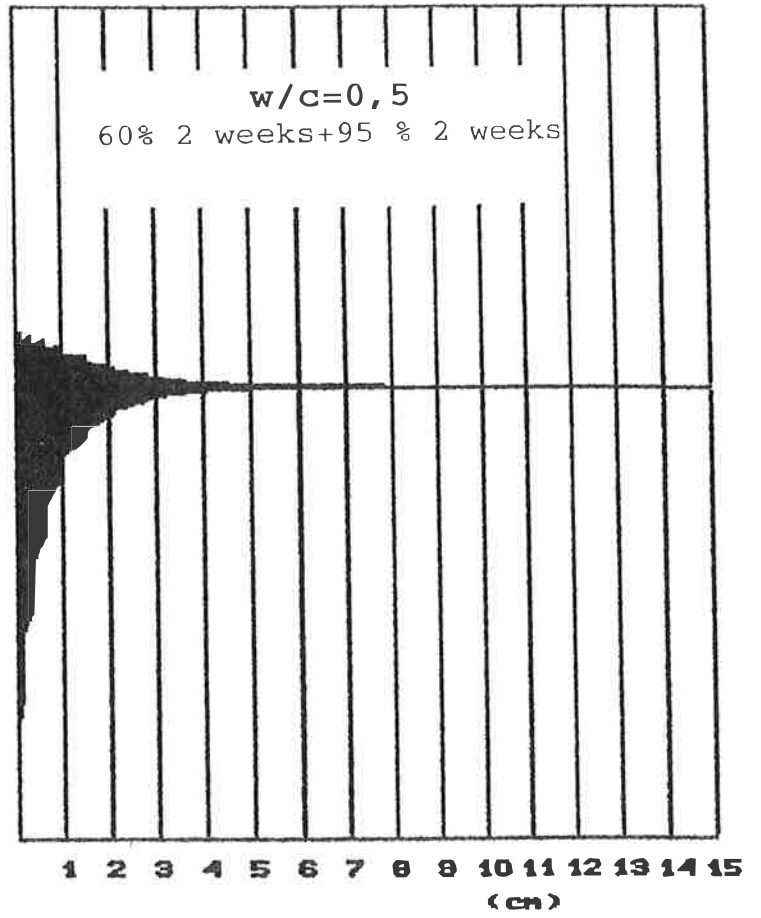

95.00
92.49
77.50
60.00

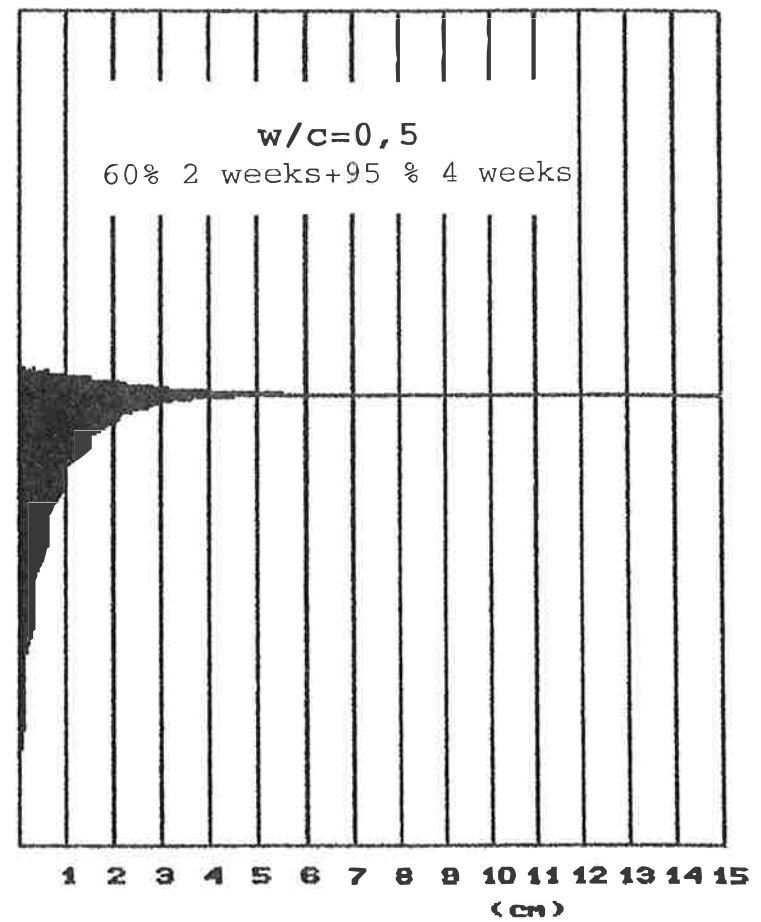

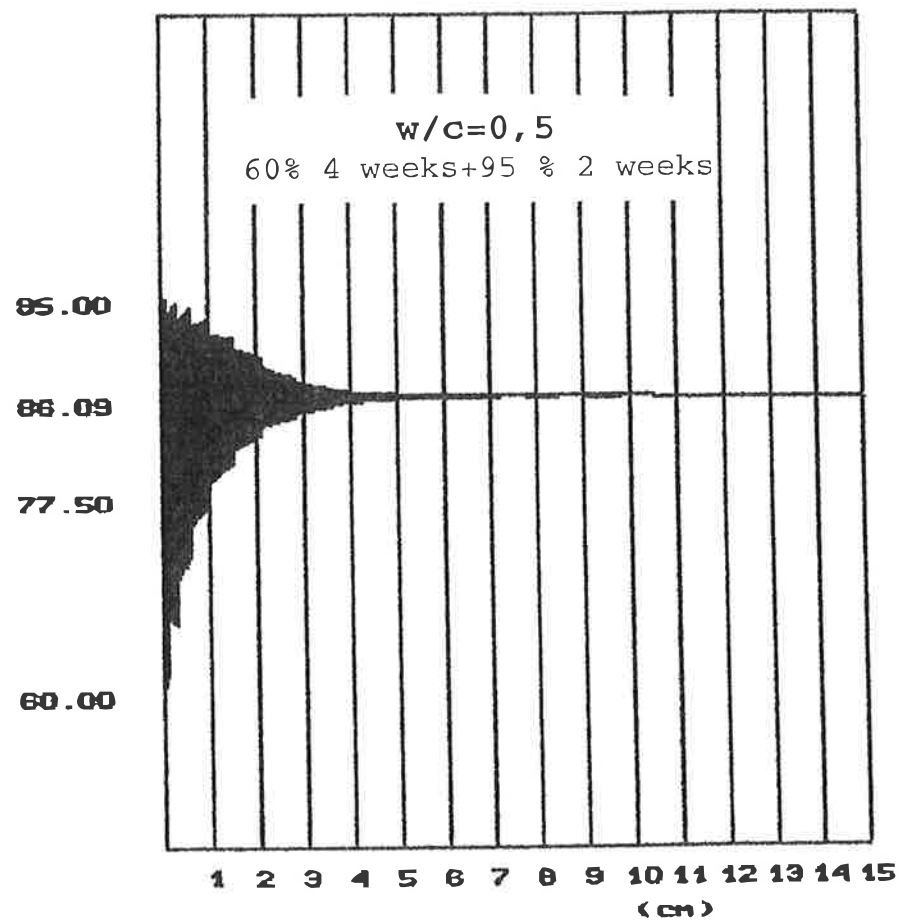
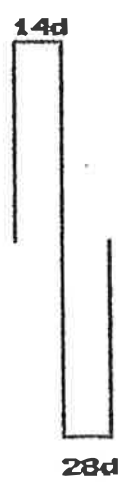
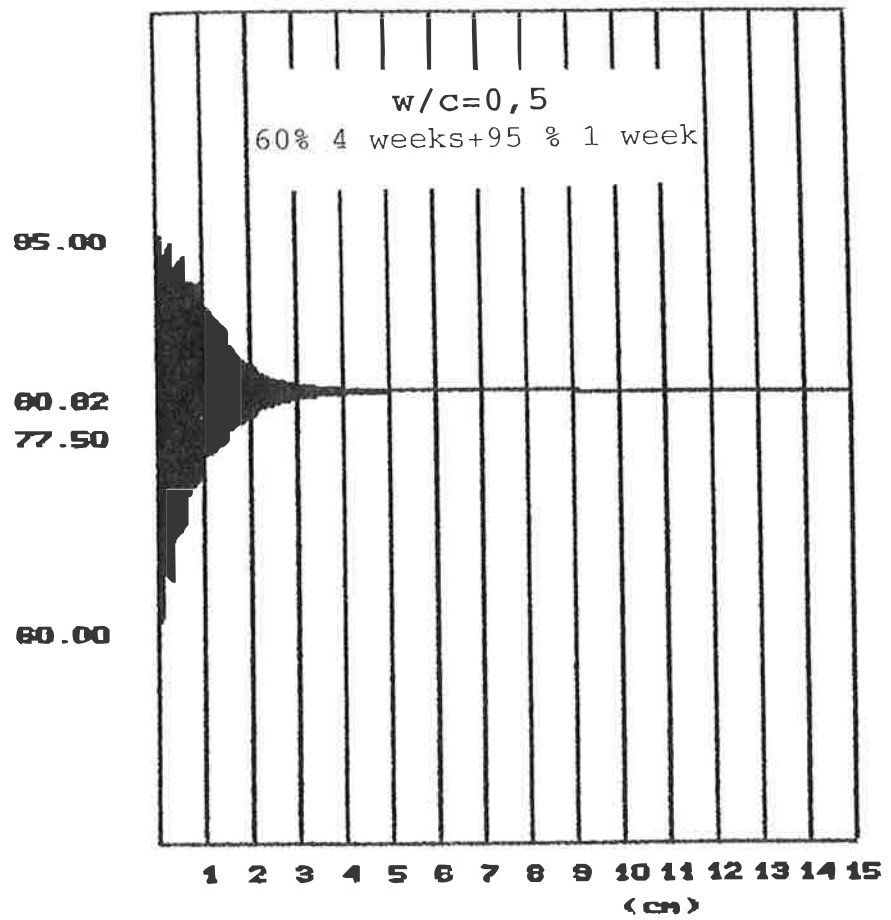
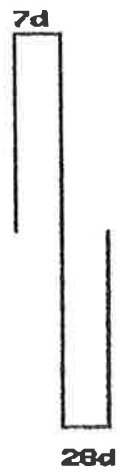

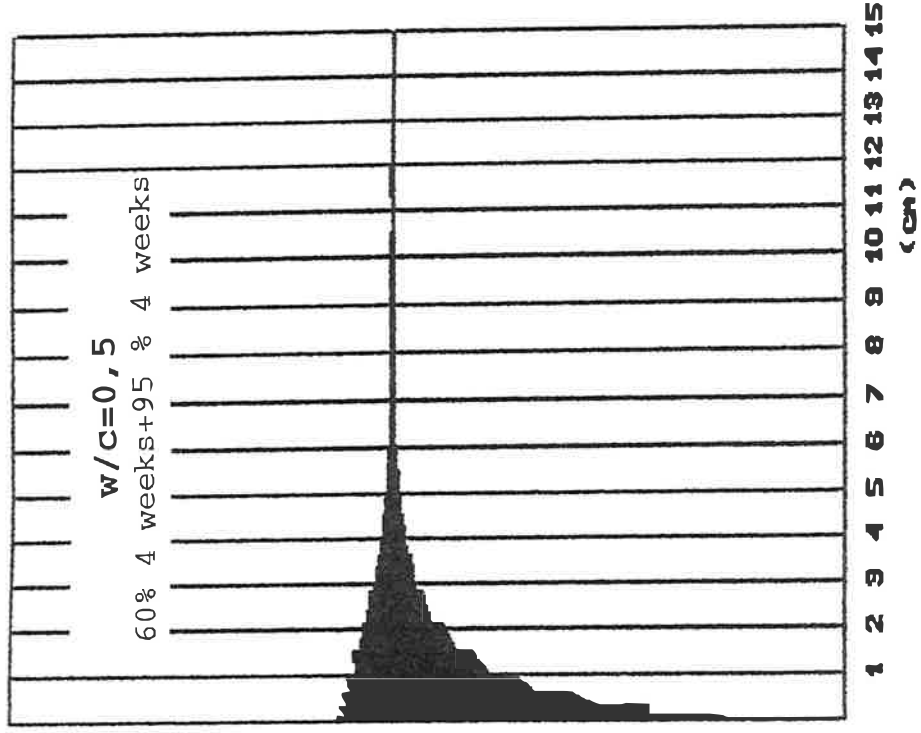
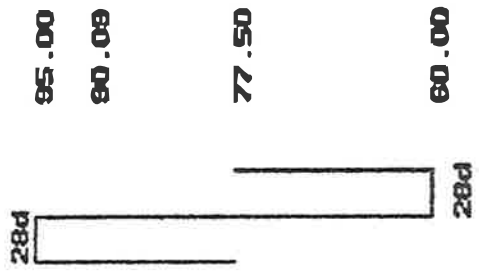

Numerical examples 3

$$w/c=0,6.$$

Not exposed to free water but to high RH



95.00
 90.13
 77.50
 60.00

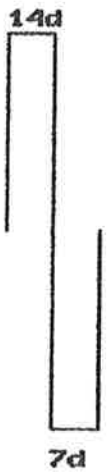
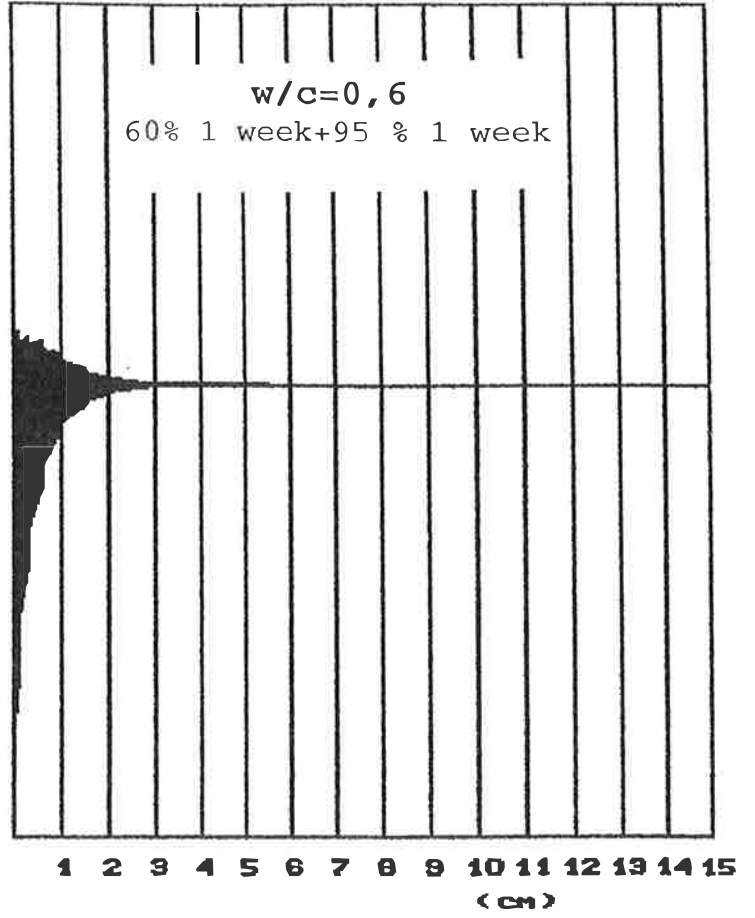

95.00
 92.51
 77.50
 60.00

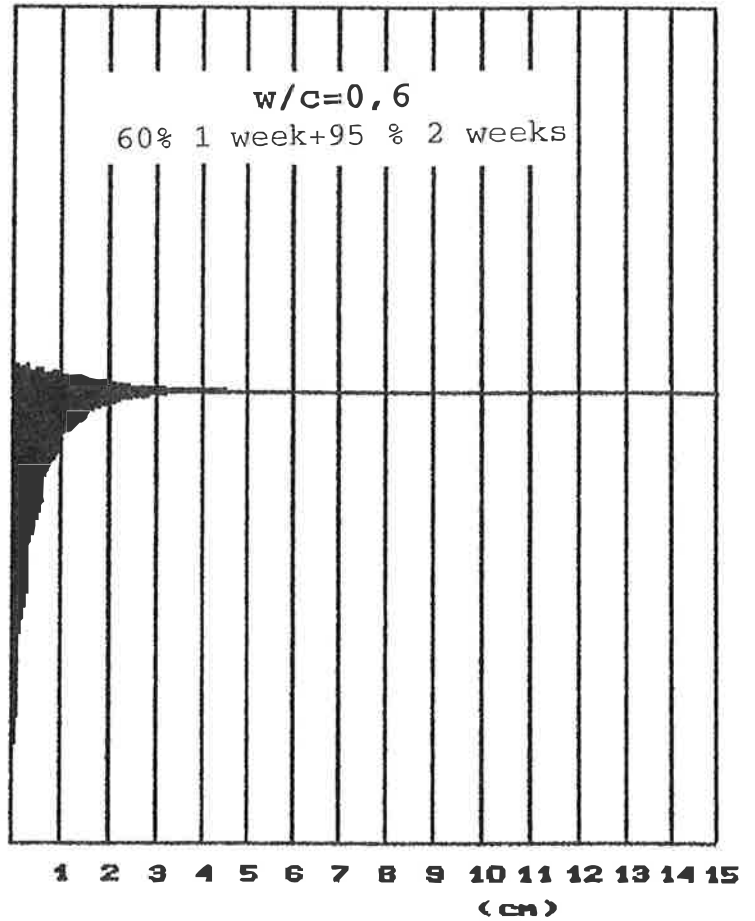

28d



7d

95.00

77.50

60.00

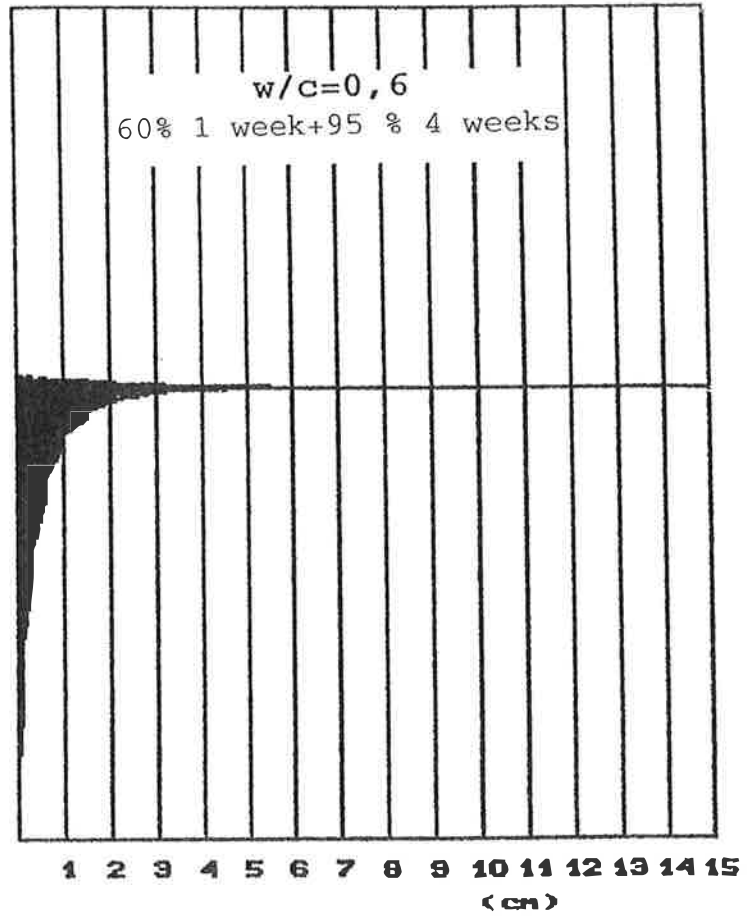

7d



14d

95.00

86.00

77.50

60.00

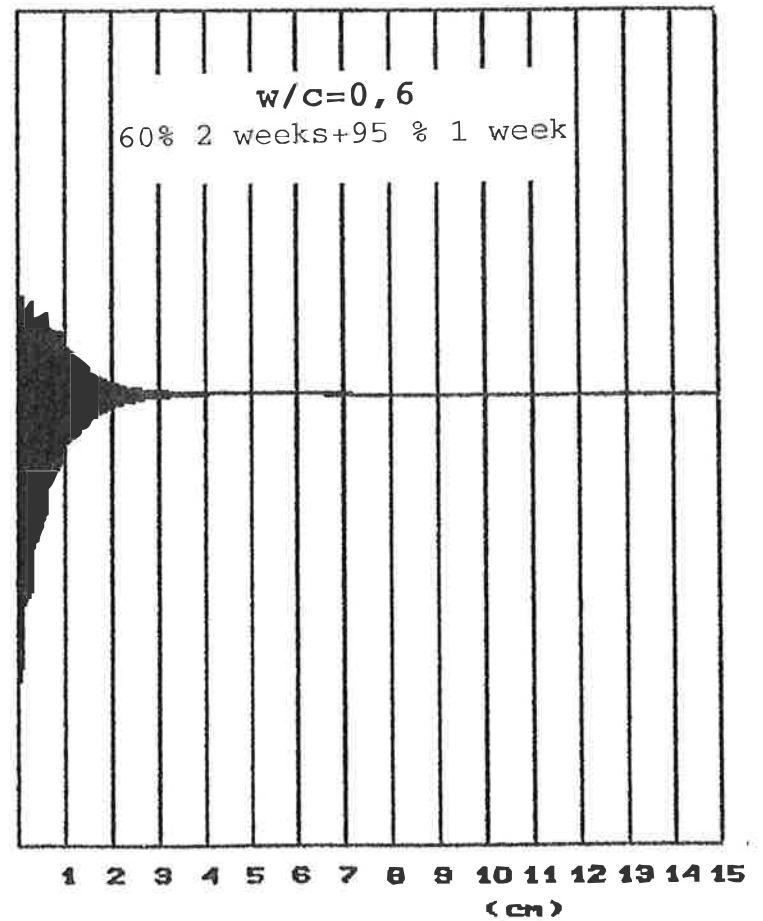

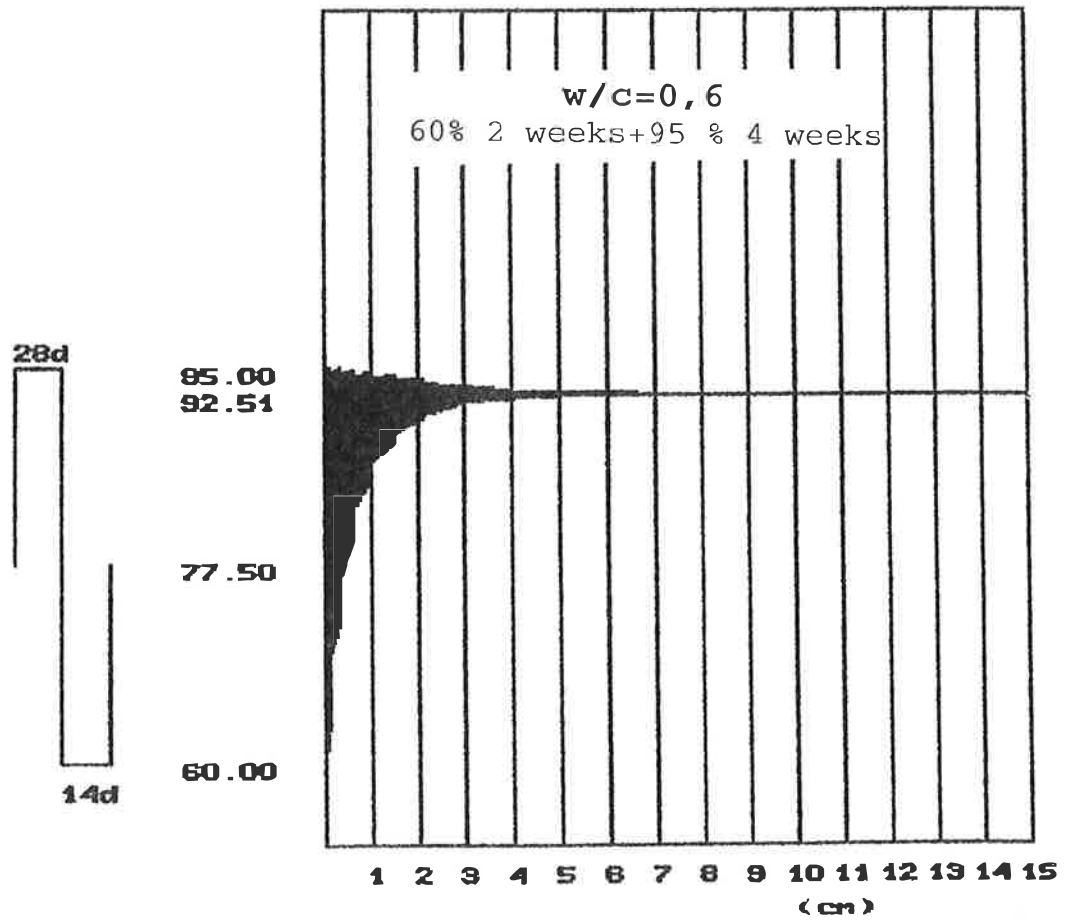
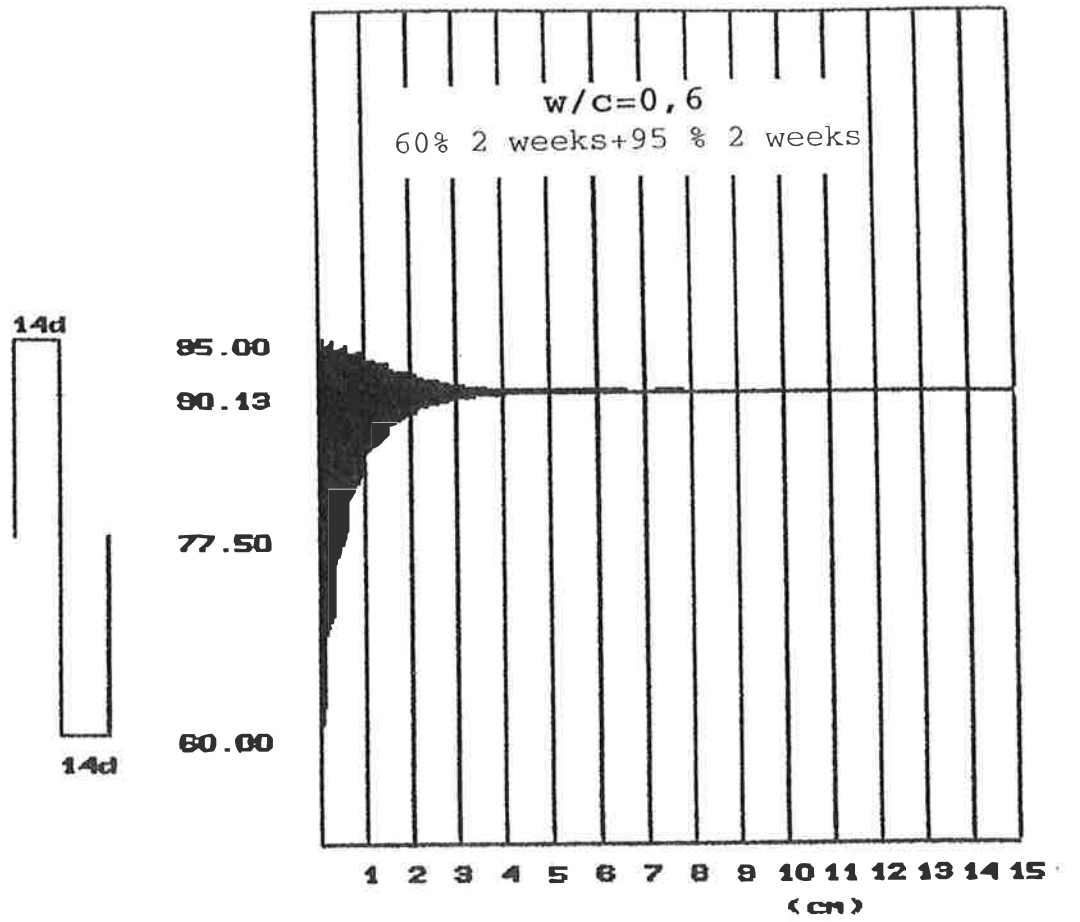

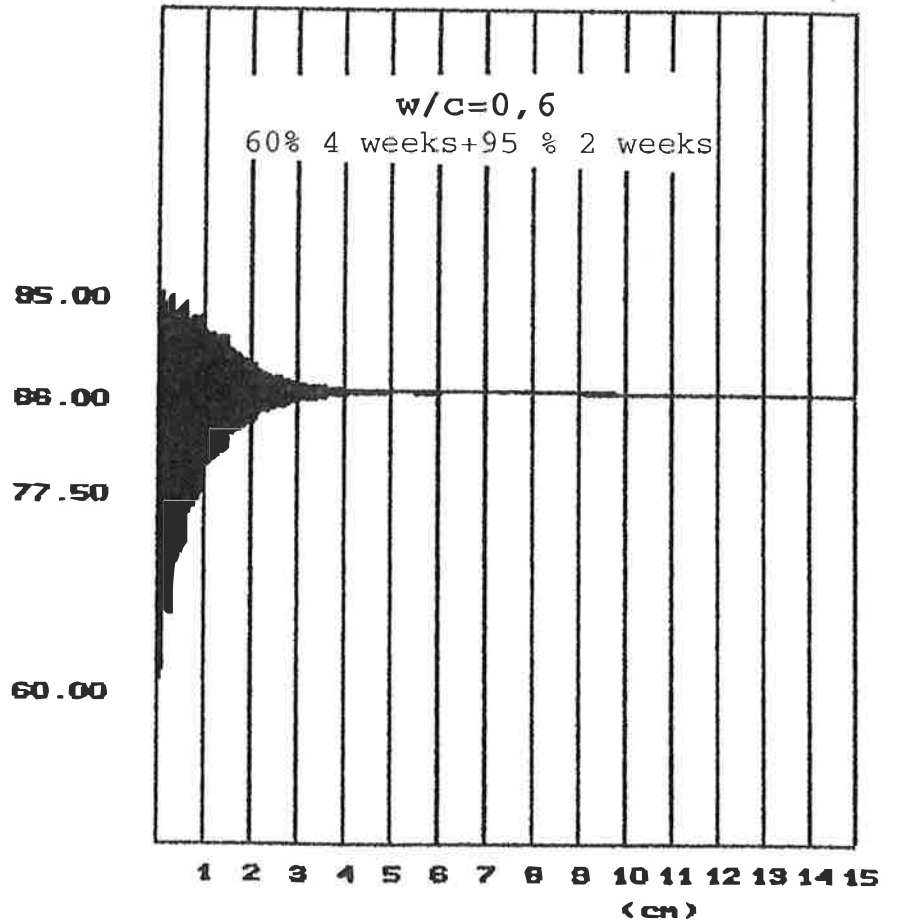
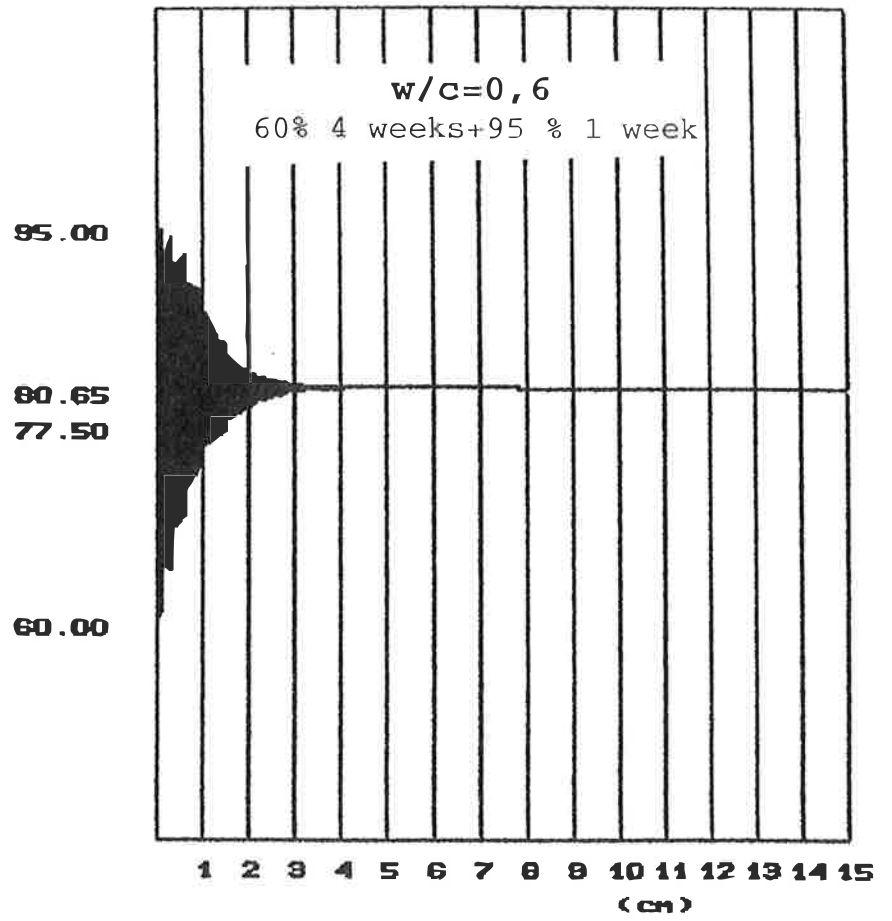

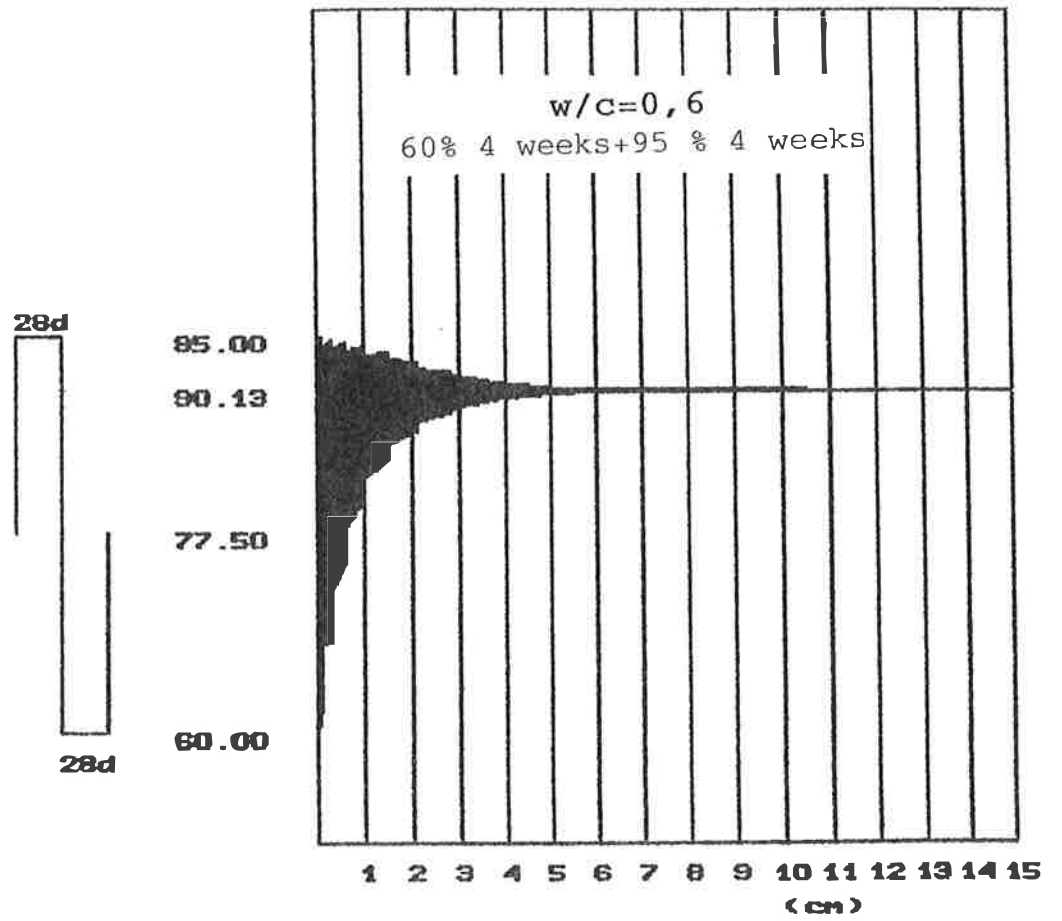

Numerical examples 4

$$w/c=0,4$$

Exposed to free water

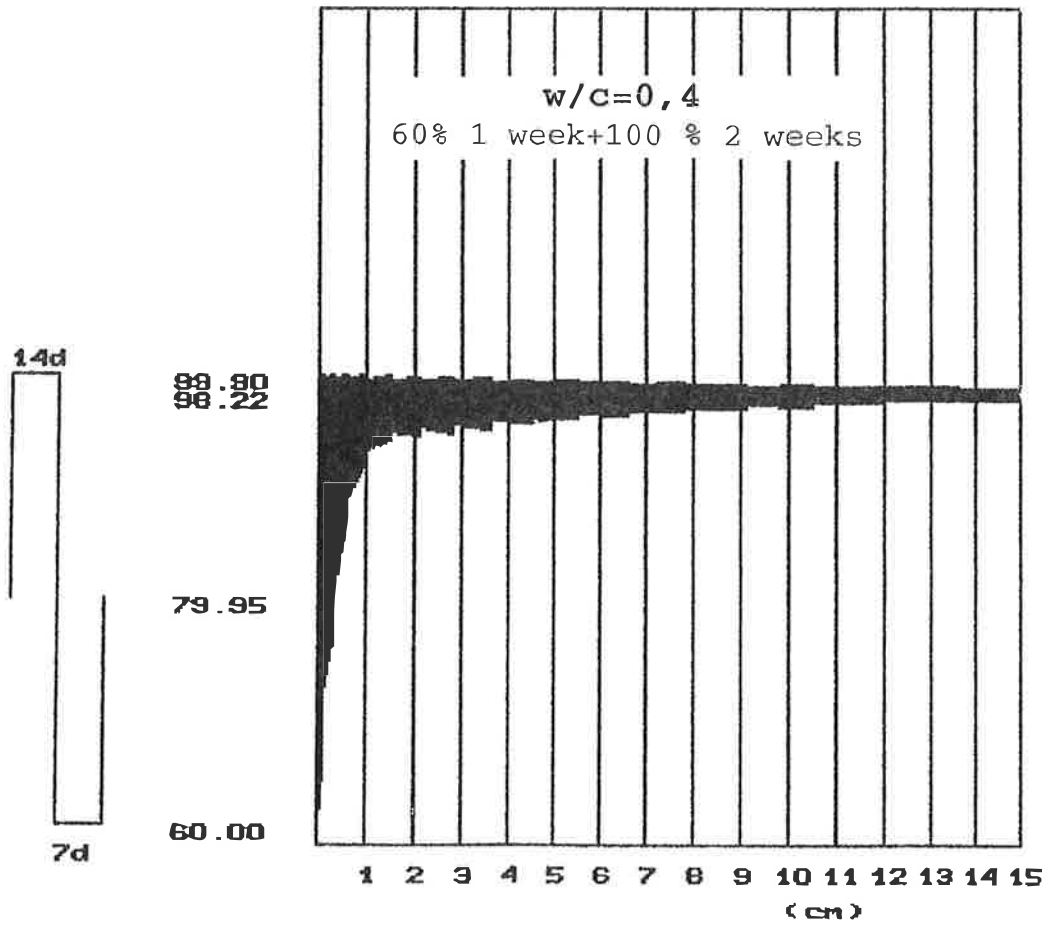
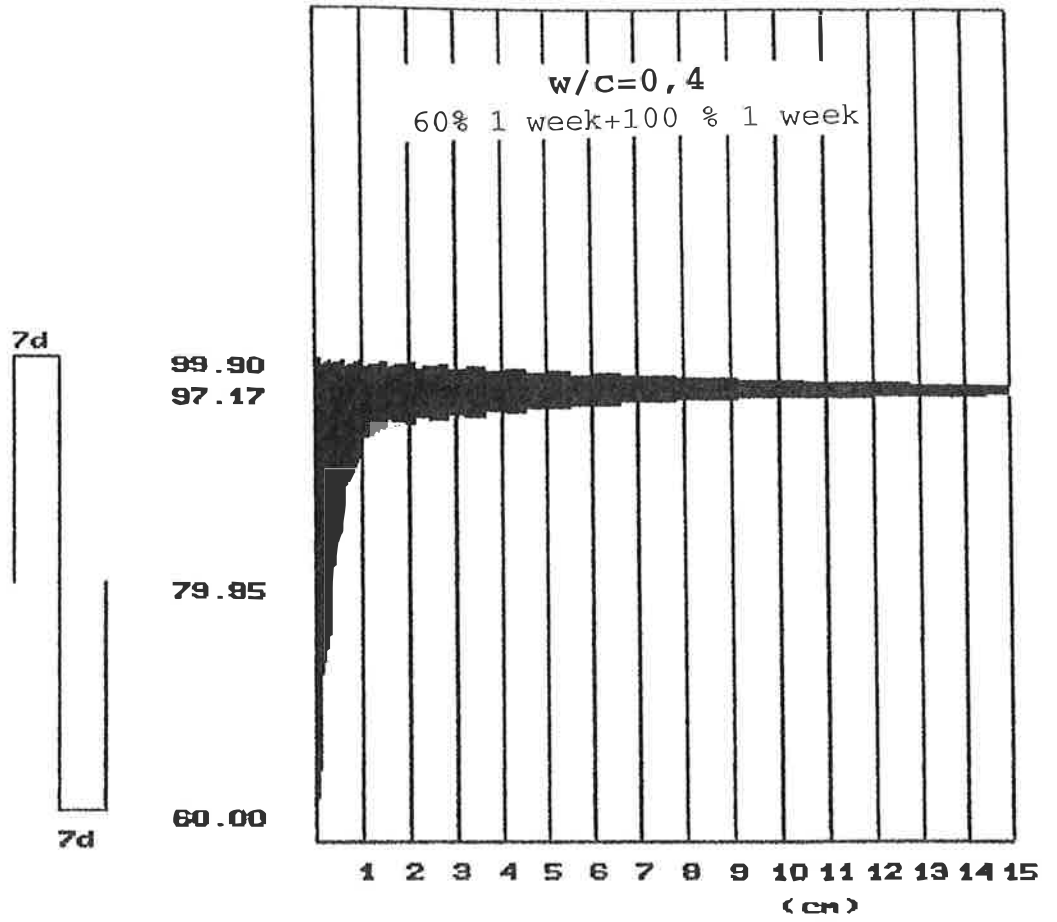

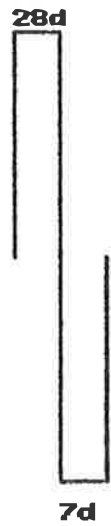

99.89
79.95
60.00

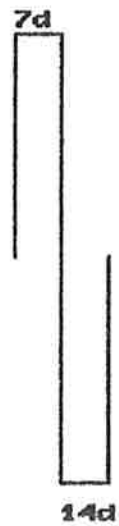
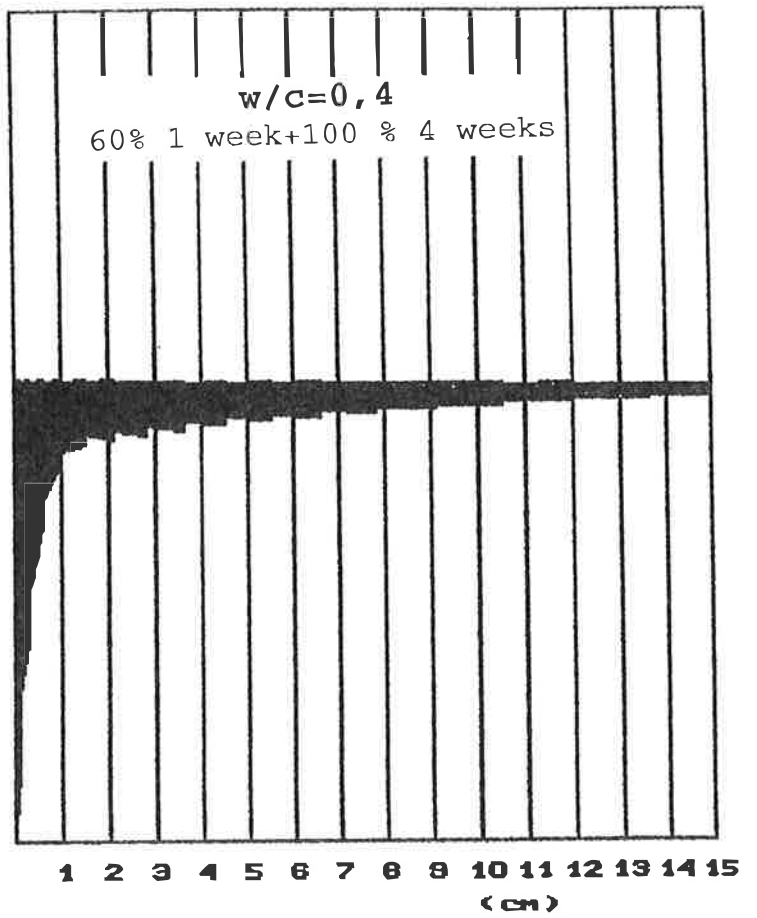

99.90
96.04
79.95
60.00

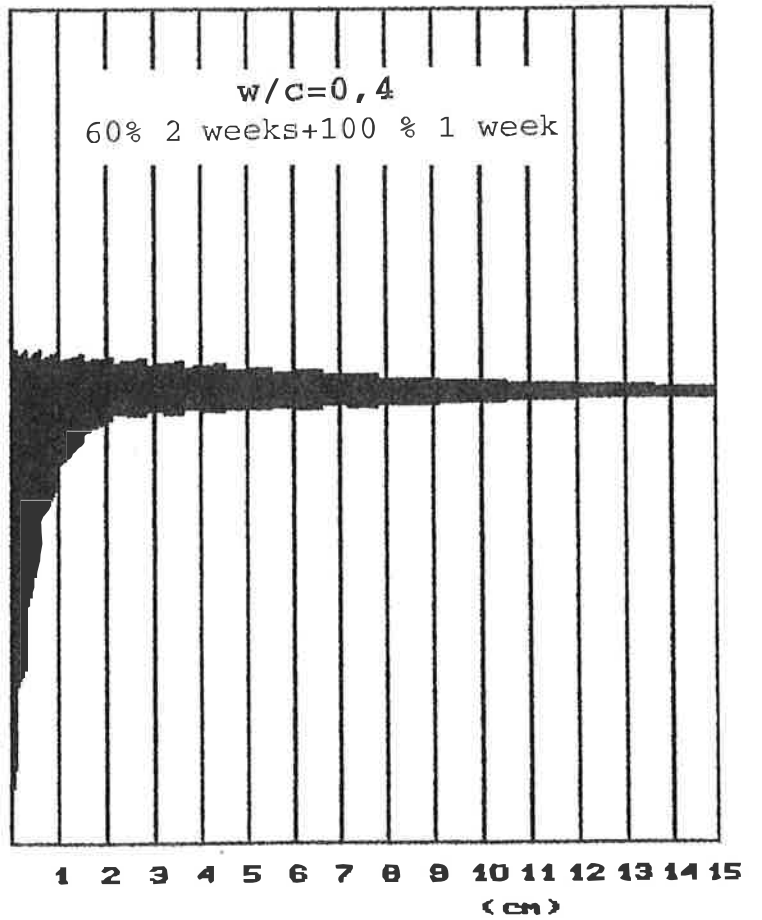

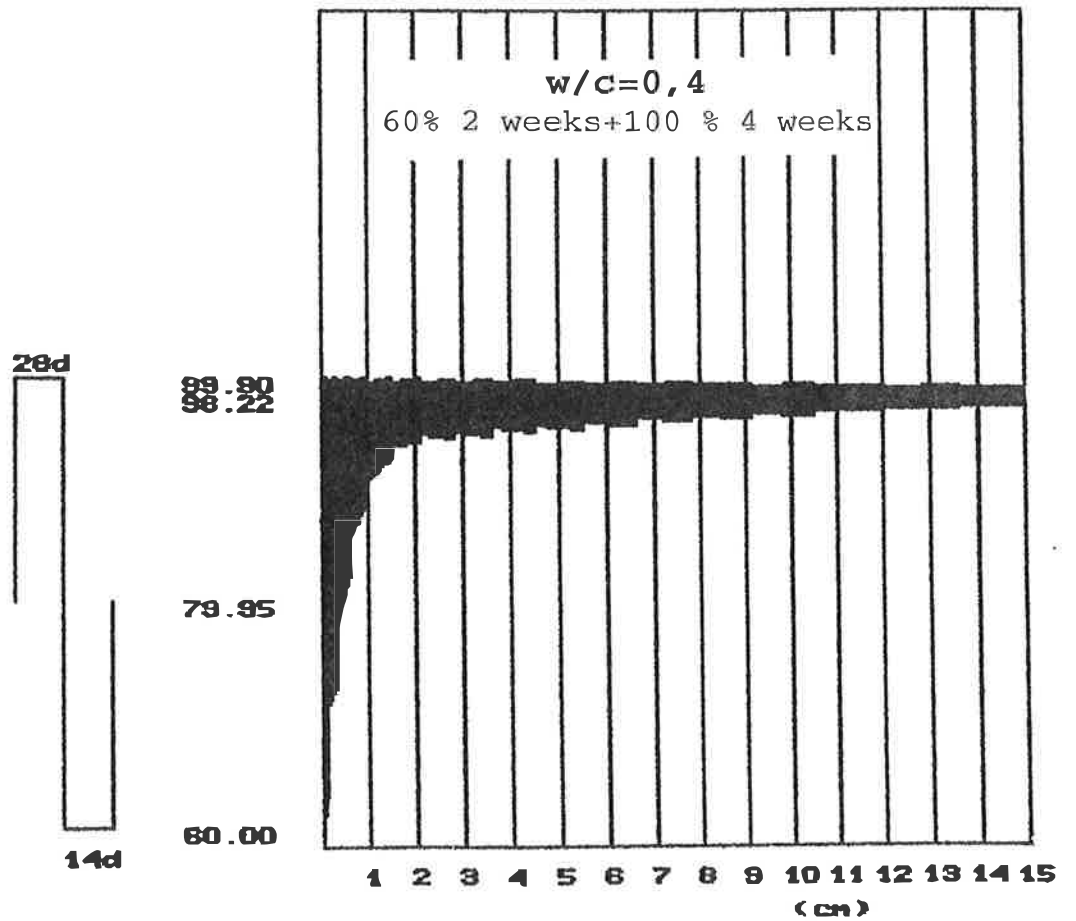
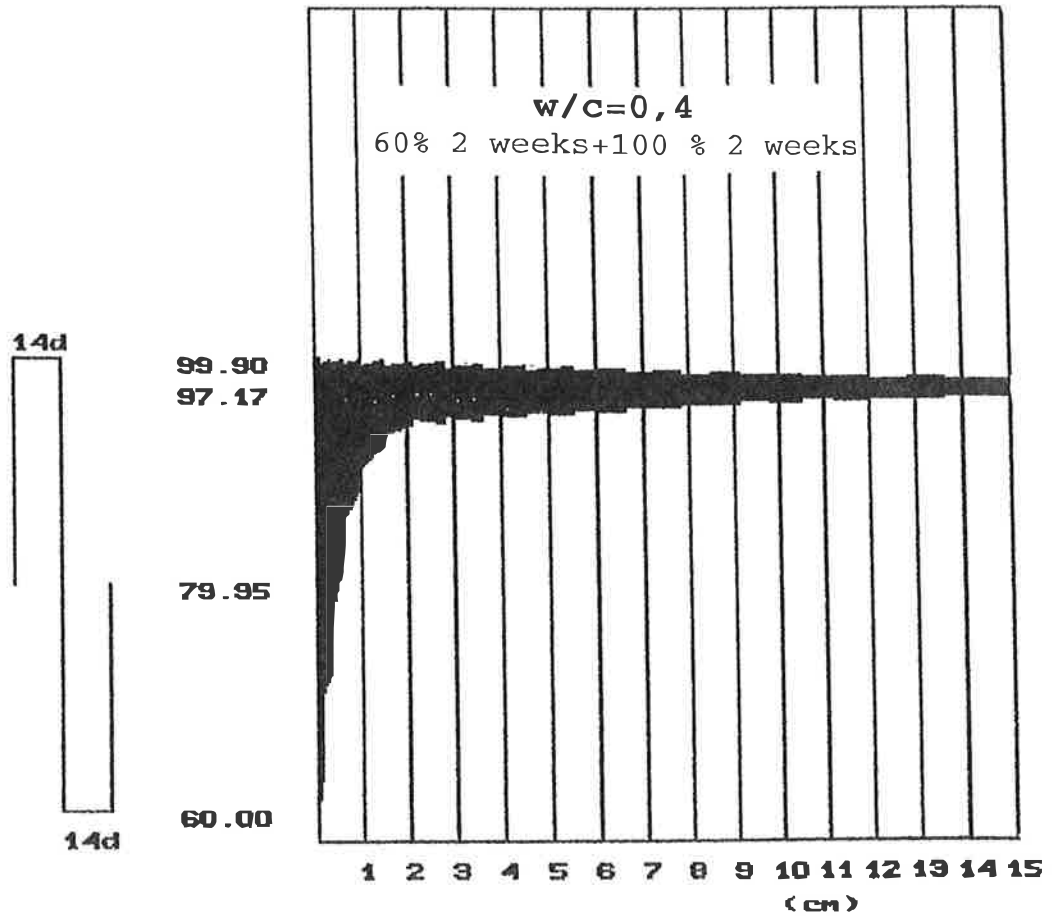

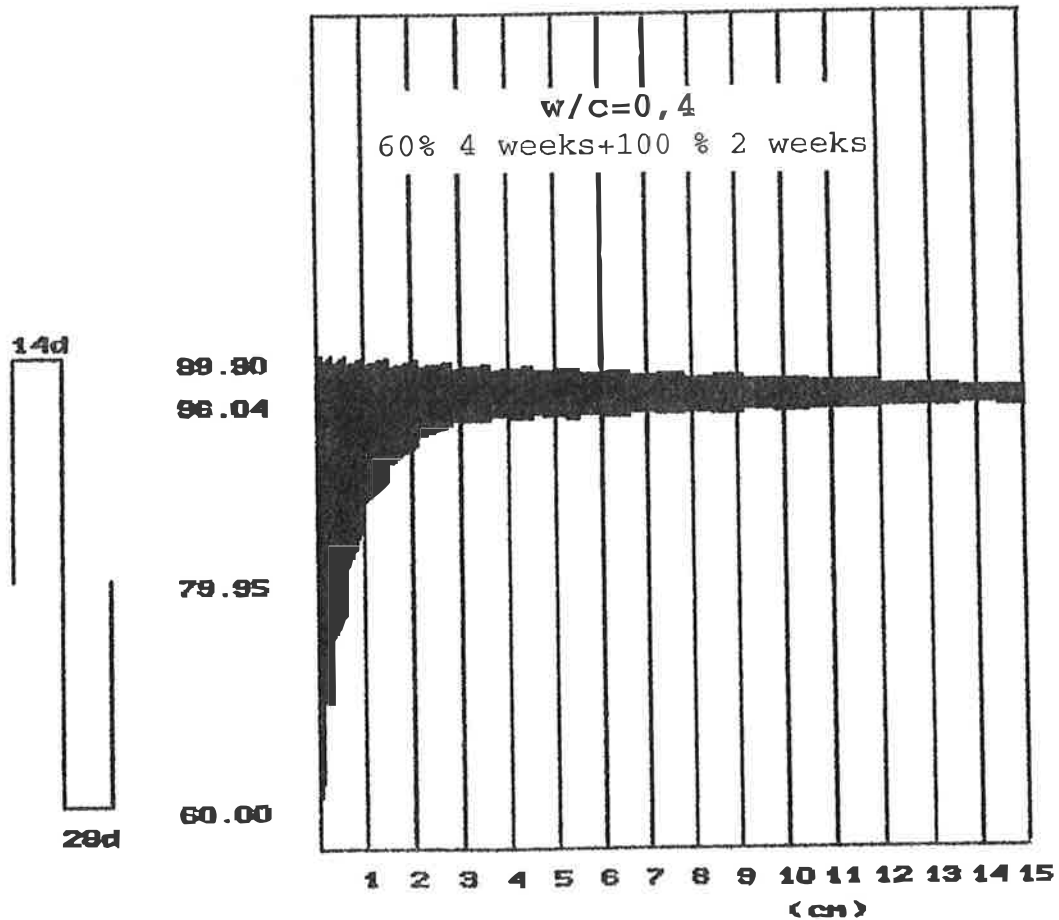
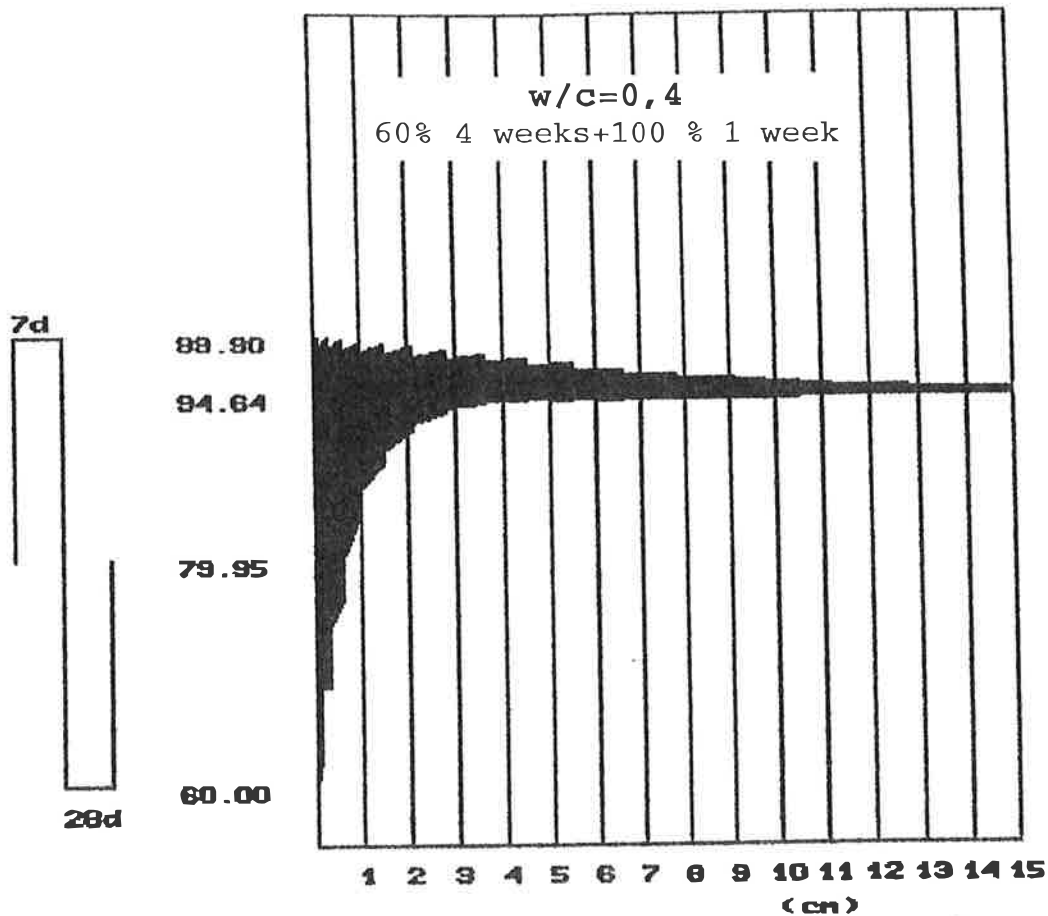

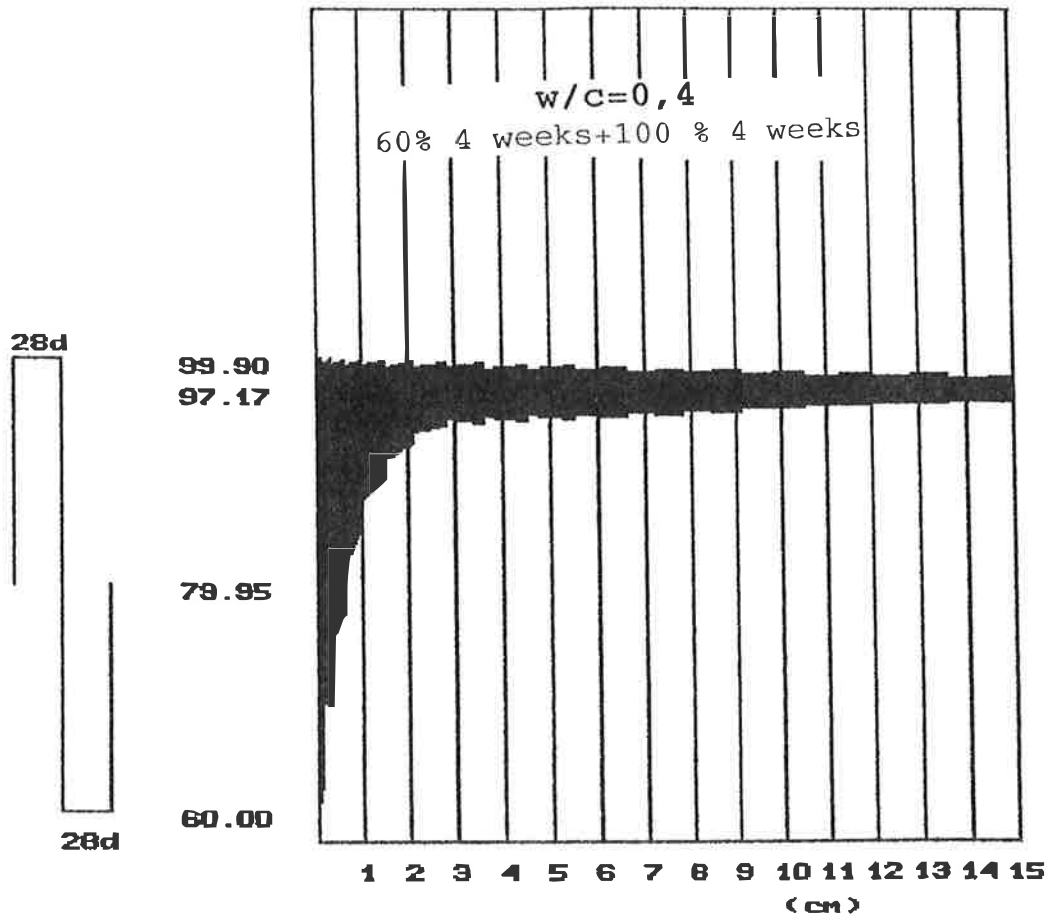

Numerical examples 5

$w/c=0,6$

Exposed to free water

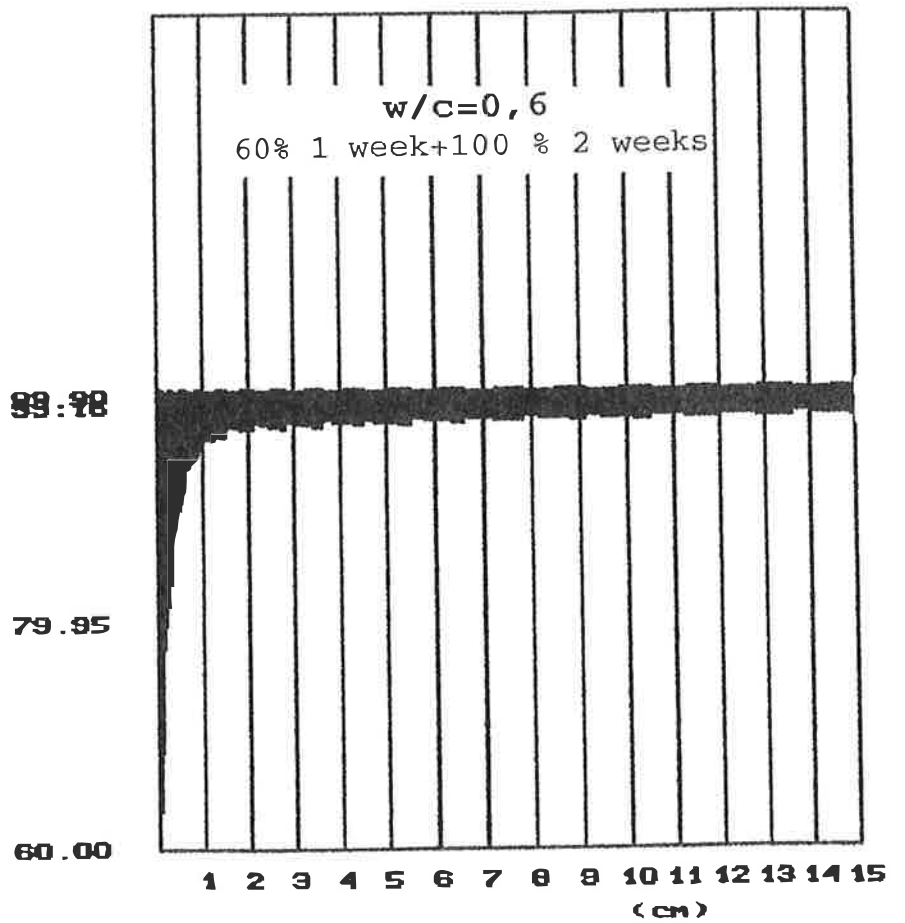
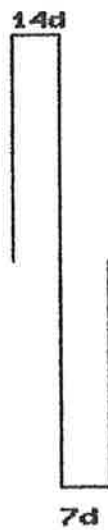
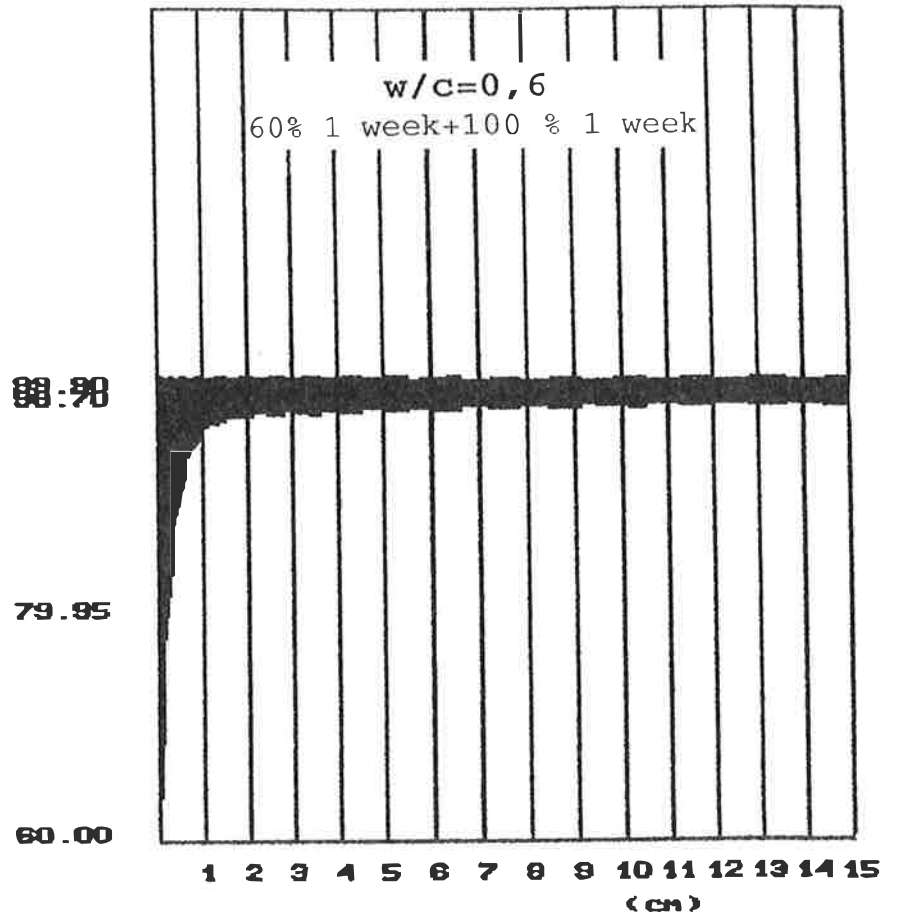

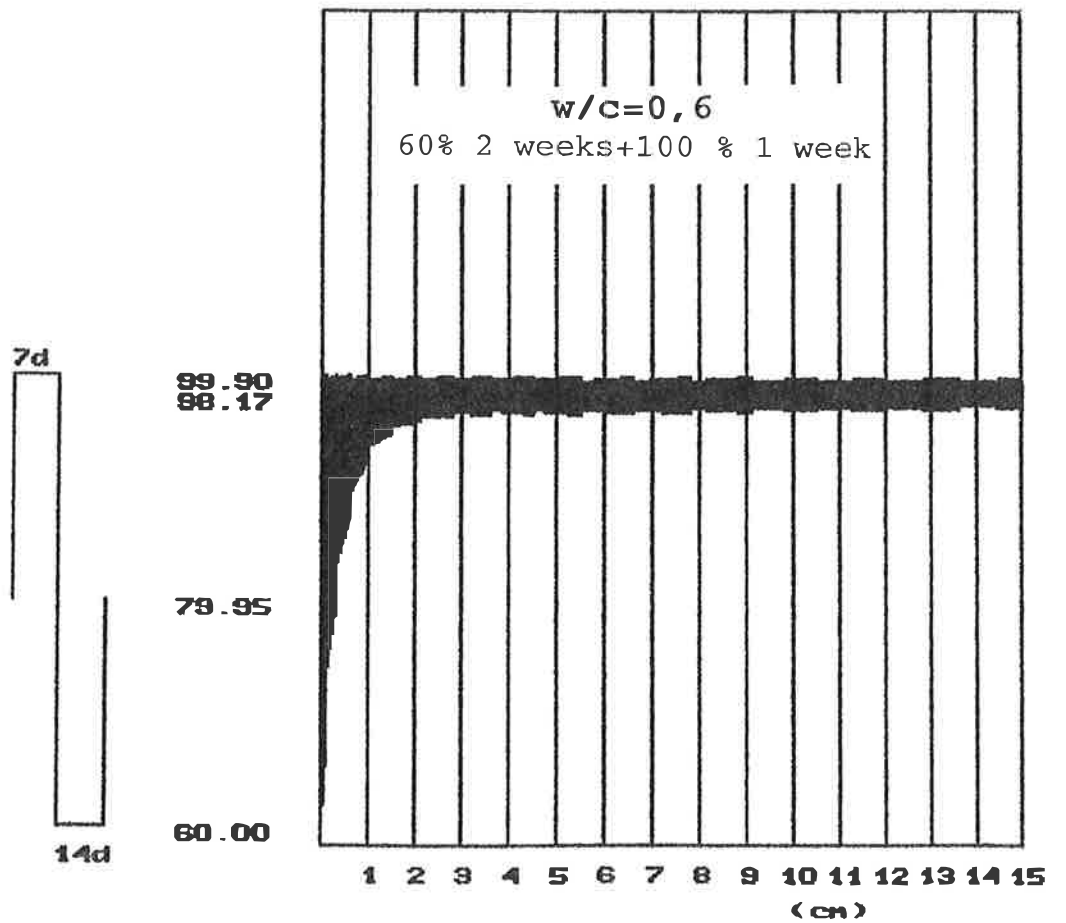
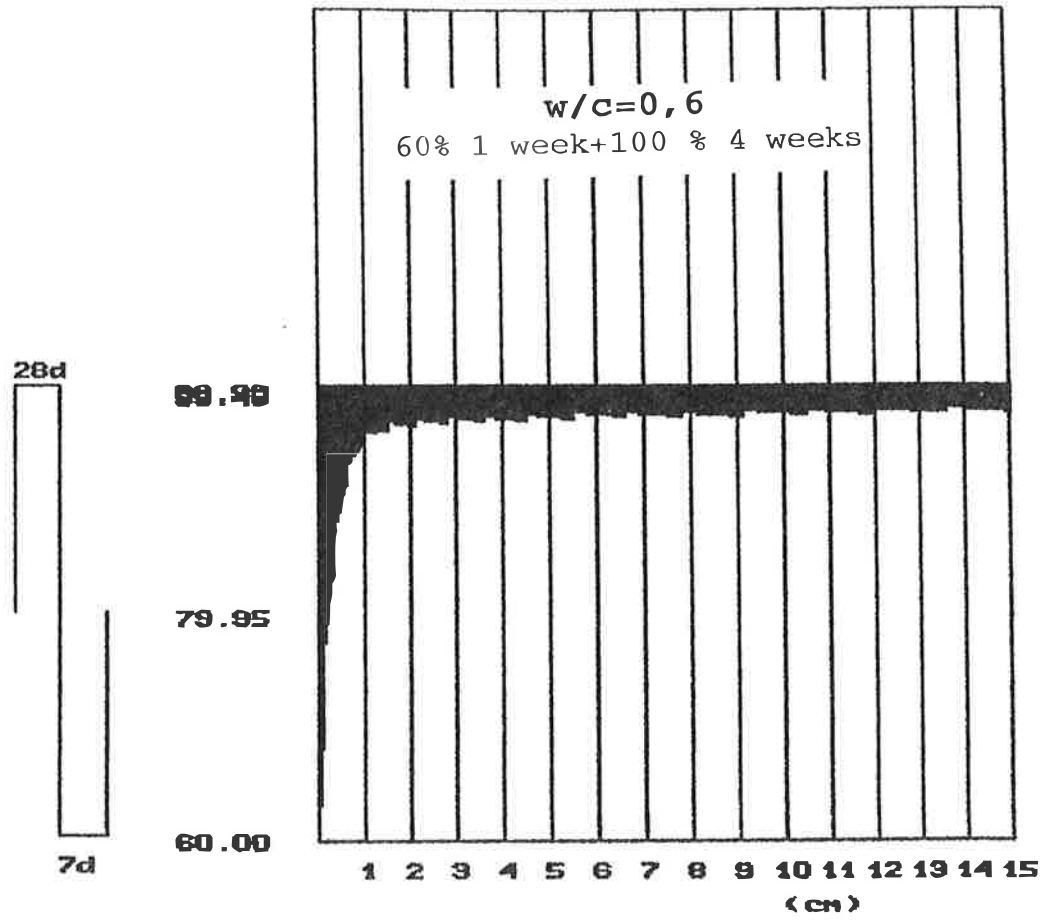

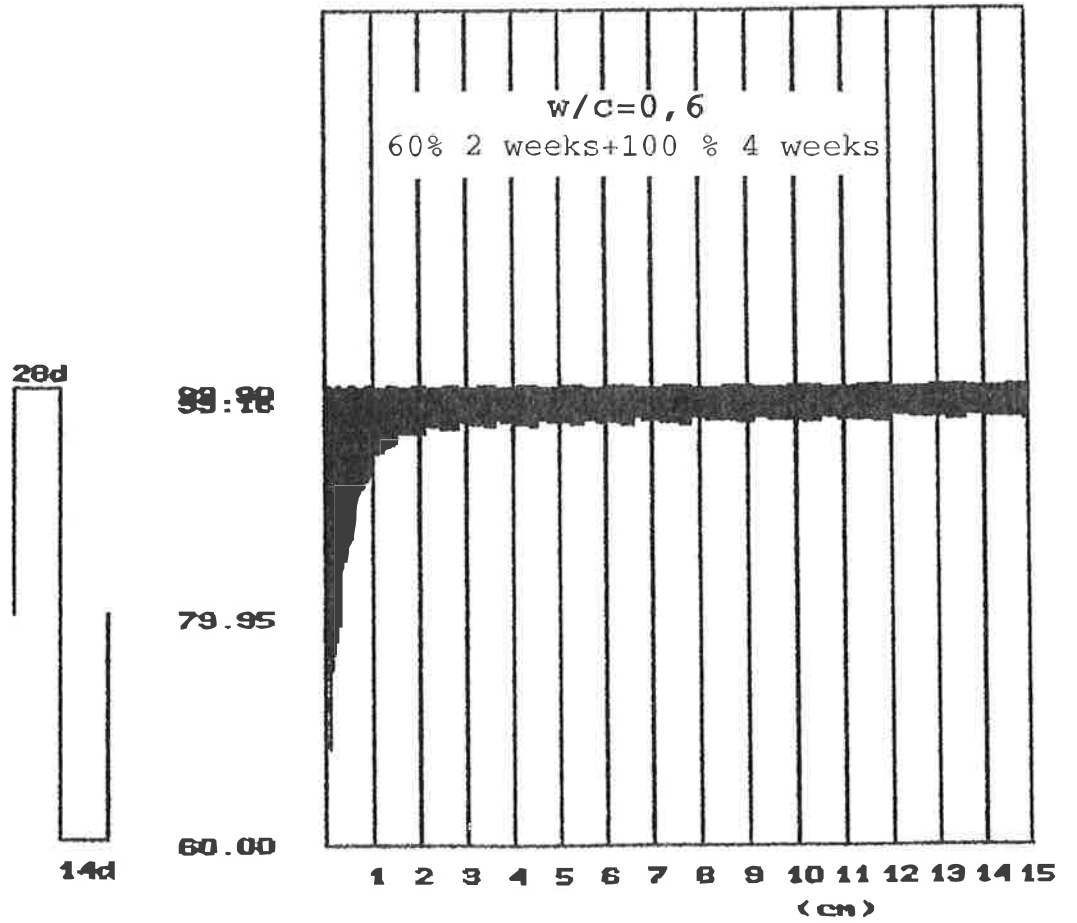
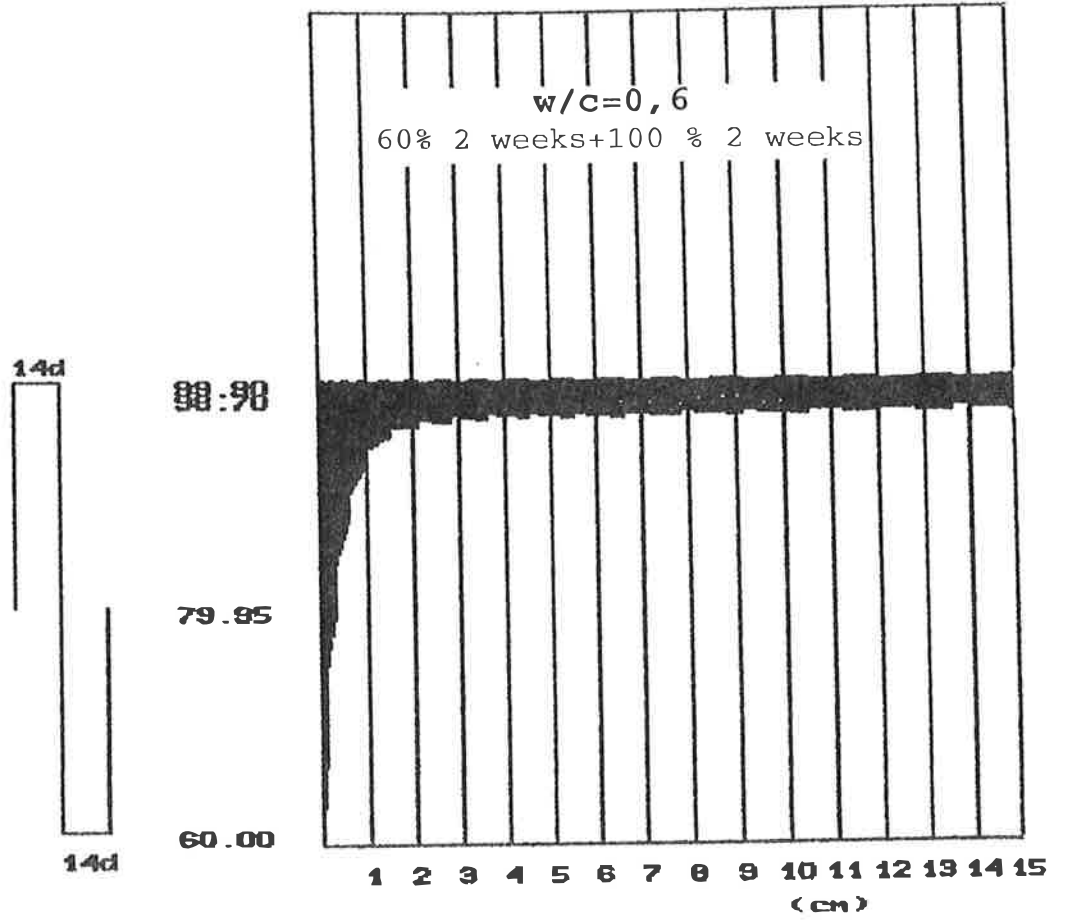

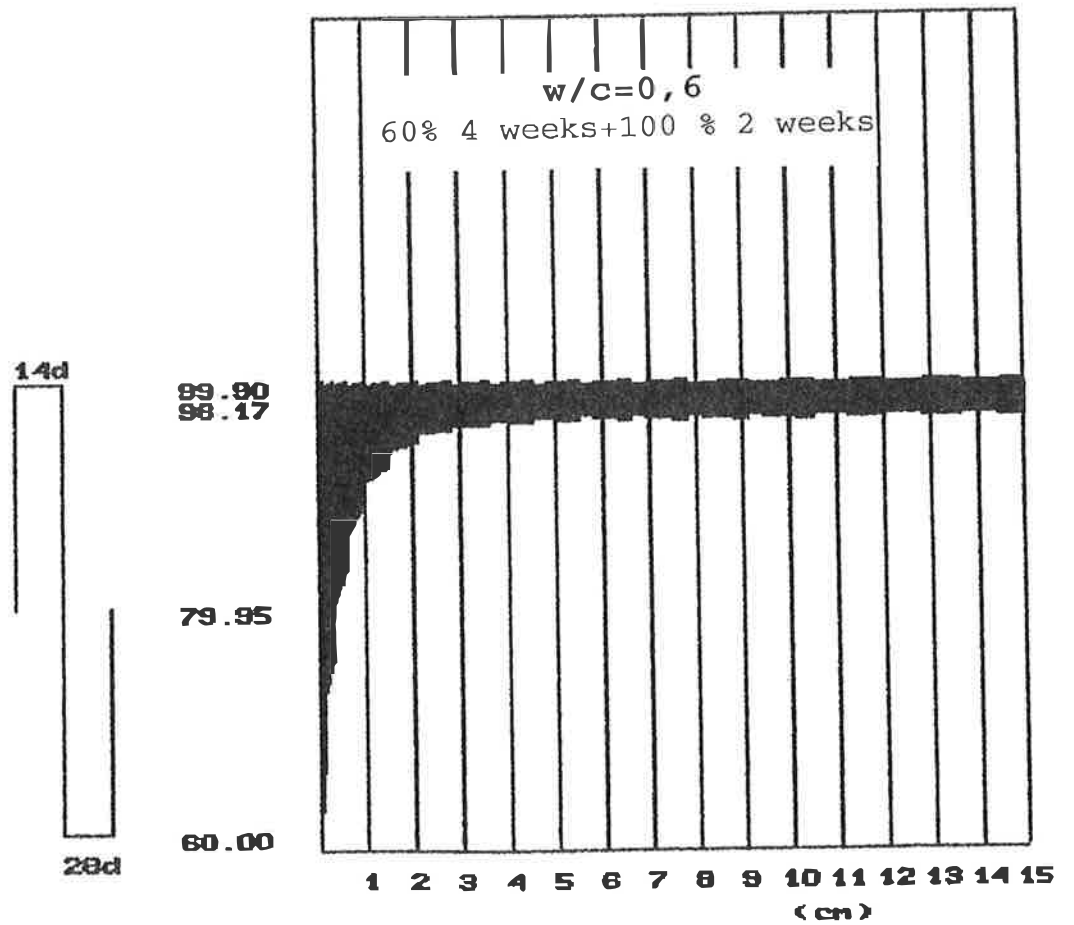
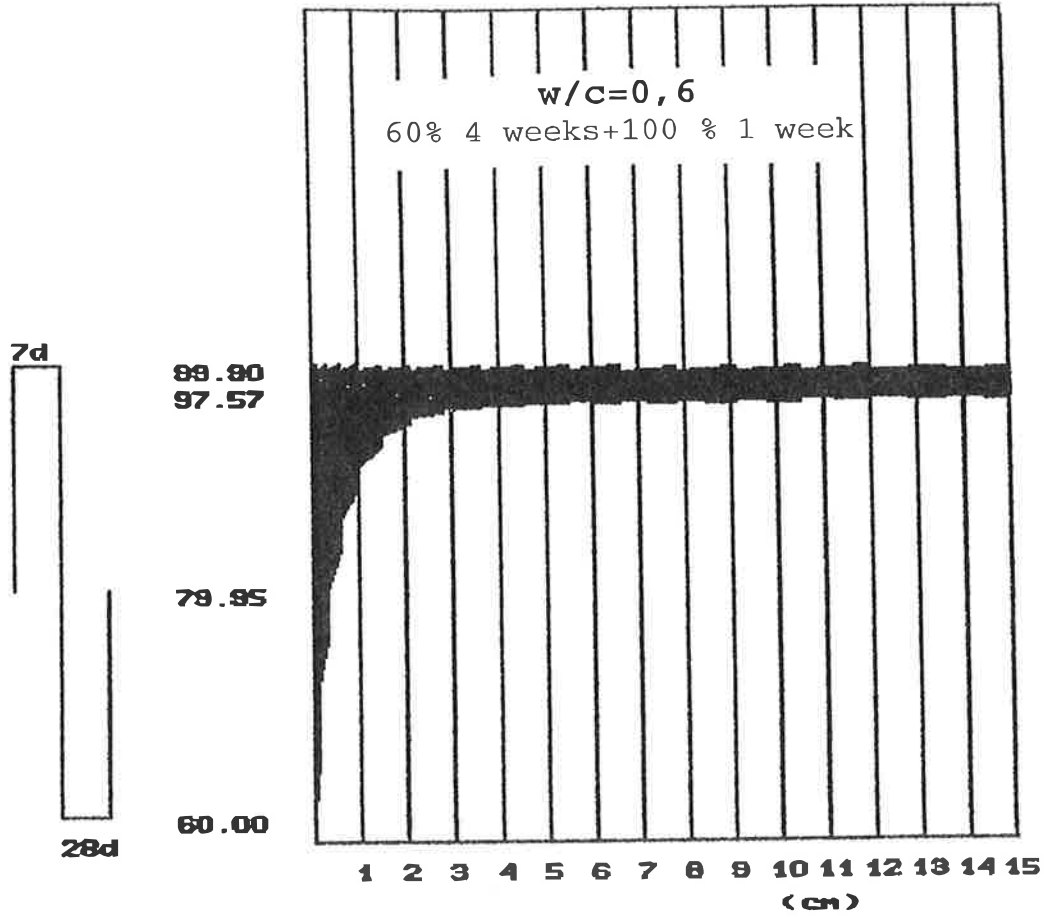

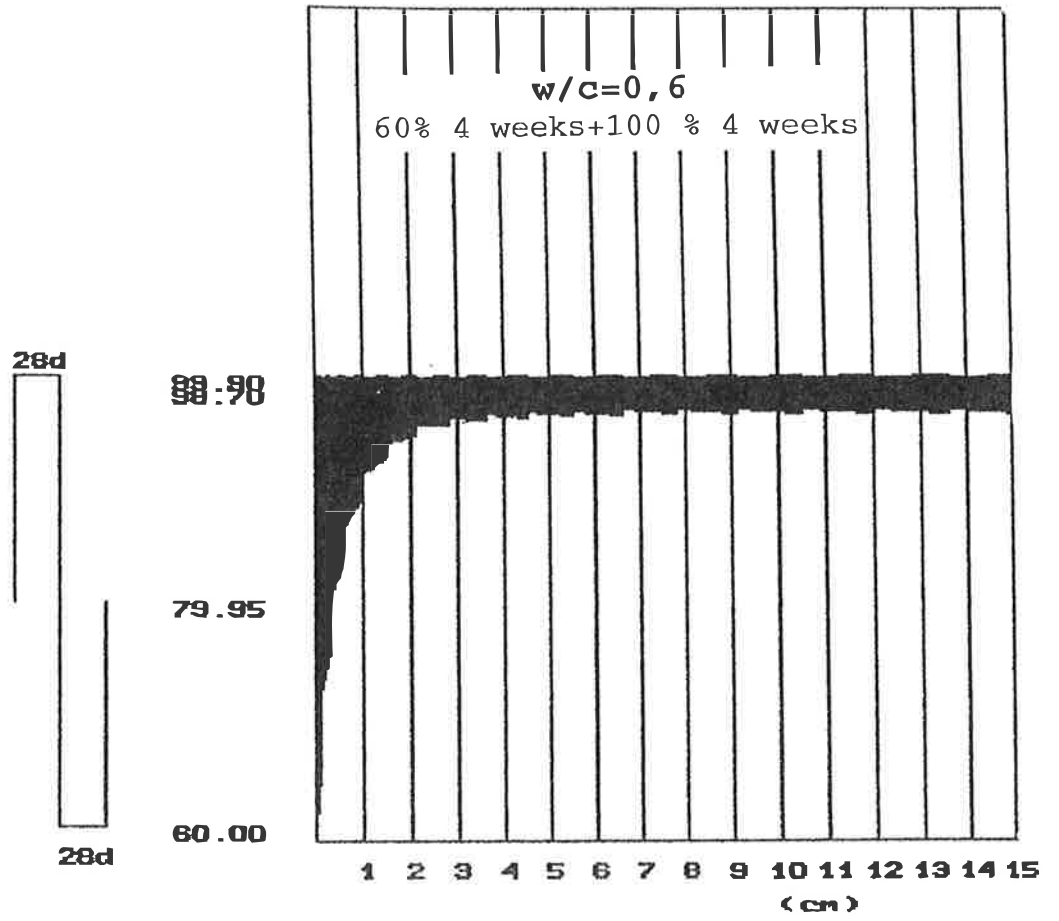

APPENDIX 2

PREVIOUS COMPUTER CALCULATIONS OF THE MOISTURE-TIME FIELD IN CONCRETE

The calculations presented below are all valid for concretes that are exposed to free water during short times. The variables are shown in Table 6.3 above.

The data have been published previously in the report /10/.

Numerical examples 1

$w/c=0,4$

Exposed to free water



99.99
RH(%)
79.99
75.91
60.00

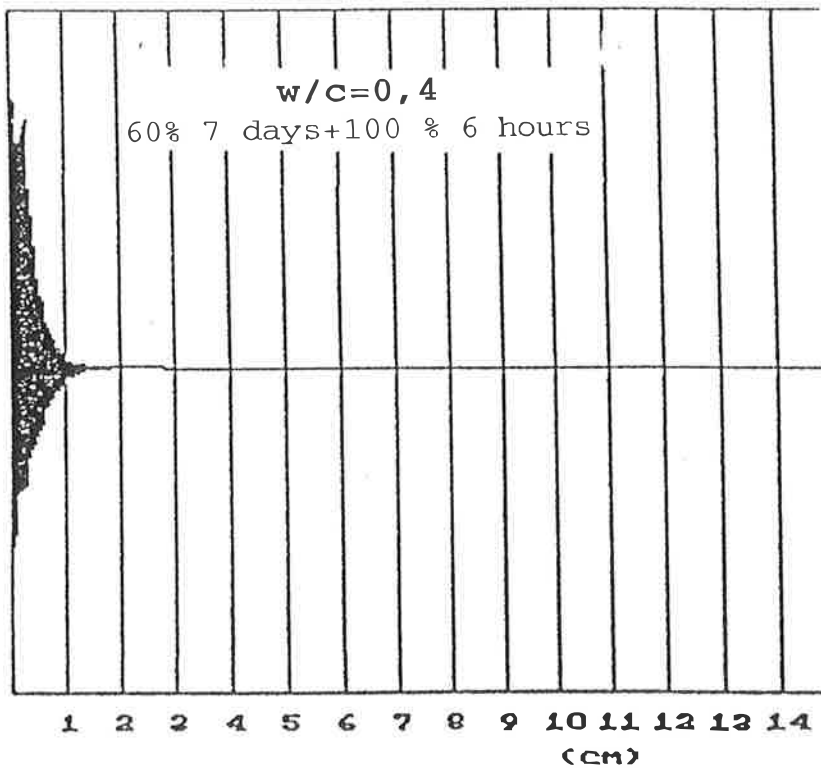

99.99
RH(%)
89.99
87.07
80.00

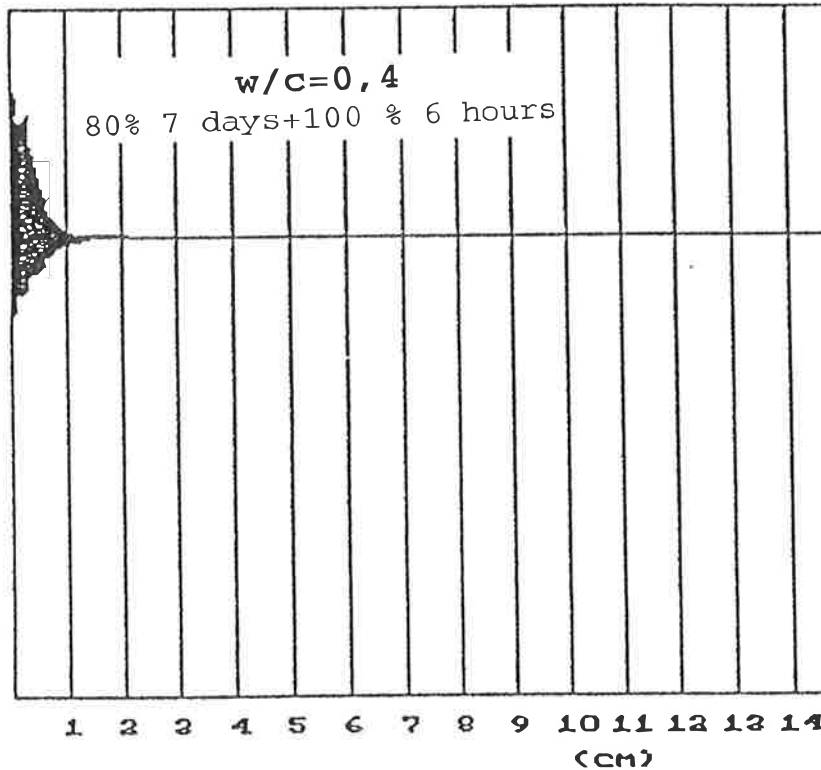



99.99
RH(%)
79.99
74.93
60.00

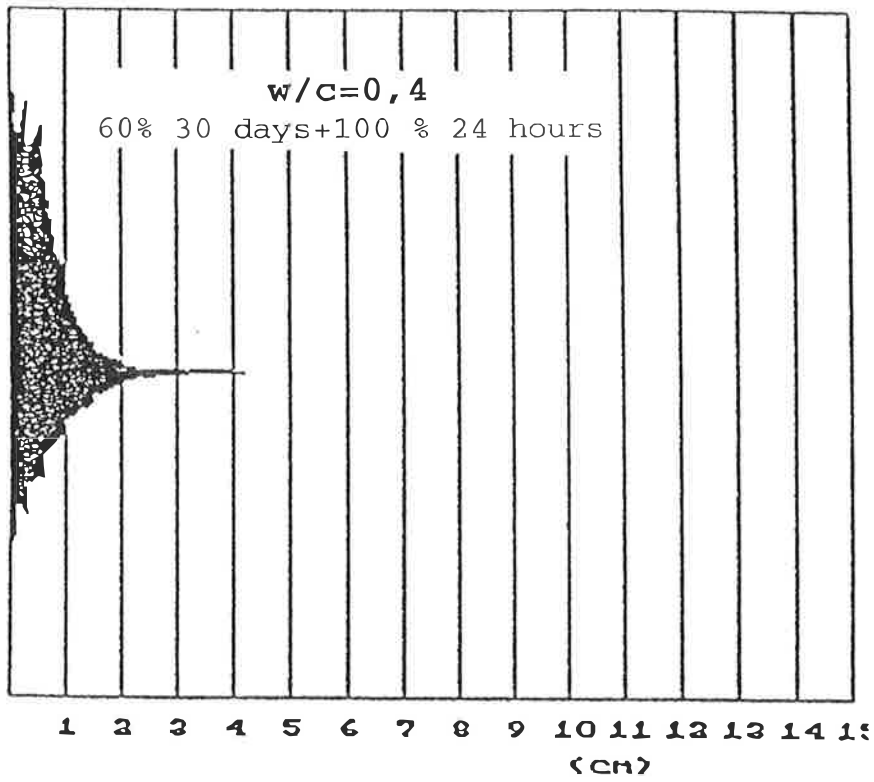

99.99
RH(%)
97.29
89.99
80.00

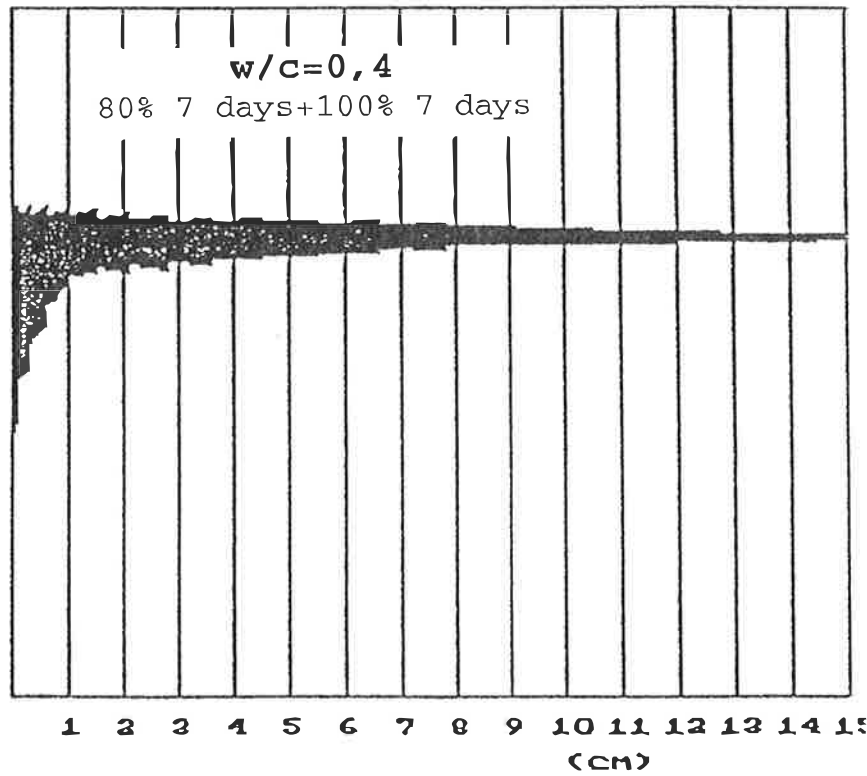

Numerical examples 2

$$w/c=0,6$$

Exposed to free water

