



# LUND UNIVERSITY

## Penetration of chloride through a submerged concrete tunnel

Fagerlund, Göran

1995

[Link to publication](#)

*Citation for published version (APA):*

Fagerlund, G. (1995). *Penetration of chloride through a submerged concrete tunnel*. (Report TVBM (Intern 7000-rapport); Vol. 7077). Division of Building Materials, LTH, Lund University.

*Total number of authors:*

1

### General rights

Unless other specific re-use rights are stated the following general rights apply:

Copyright and moral rights for the publications made accessible in the public portal are retained by the authors and/or other copyright owners and it is a condition of accessing publications that users recognise and abide by the legal requirements associated with these rights.

- Users may download and print one copy of any publication from the public portal for the purpose of private study or research.
- You may not further distribute the material or use it for any profit-making activity or commercial gain
- You may freely distribute the URL identifying the publication in the public portal

Read more about Creative commons licenses: <https://creativecommons.org/licenses/>

### Take down policy

If you believe that this document breaches copyright please contact us providing details, and we will remove access to the work immediately and investigate your claim.

LUND UNIVERSITY

PO Box 117  
221 00 Lund  
+46 46-222 00 00

CODEN:LUTVDG/(TVBM-7077)/1-17/1995  
ISSN 0348-7911

---

# PENETRATION OF CHLORIDE THROUGH A SUBMERGED CONCRETE TUNNEL

Göran Fagerlund

Contents	Page
Summary	1
1. Introduction	2
2. Mechanism 1: Diffusion	2
3. Mechanism 2: Convective flow without hydraulic head	5
3.1 Theory	5
3.2 Chloride penetration and enrichment in the submerged tunnel	9
4. Mechanism 3: Convective flow with hydraulic head	12
5. Mechanism 4: Convective flow through cracks	13
5.1 Crack types	13
5.2 Cracks of type 1	13
5.3 Cracks of type 2	14
5.4 Cracks of type 3	14
6. Suggested general requirements	16
References	17

## Summary

A concrete tunnel for car and/or railway traffic, that is submerged in sea water, is exposed to long-term constant water pressure causing water and chloride to flow through the external roof, walls, and floor. The chlorides will accumulate at the downstream face. The flow of chloride will be convective when the concrete is of low quality, or when it contains through cracks. It will be diffusive when the concrete is dense. Diffusive flow is of course much smaller than convective flow.

Structures of this type will have a required life time that is very high; 100 years or more. Theoretically, very large amounts of chlorides might accumulate at the downstream face during this very long time of service life. Thus, the risk of reinforcement corrosion is very high. The only solutions are, either to protect the concrete by an impermeable membrane of steel or concrete, or to make the concrete so dense, that the chloride transport will be so low, that the threshold concentration for onset of corrosion cannot be reached during the entire, required service life. Another prerequisite is of course, that there is no through cracks in the concrete.

In this report, new experimental data for transport of water through mature concrete is used for analysing the maximum possible convective flow through uncracked concrete with no protective membrane. It is shown theoretically, that rather small amounts of chloride will accumulate at the downstream face when the concrete is thick and of high quality. It seems as if the risk, that the reinforcement corrosion shall start within 100 years, is fairly low. In cracked concrete, very large amounts of chloride will penetrate, and corrosion will start early, and it will be very rapid.

The report ends with some recommendations for the selection of concrete quality and constituents.

## 1. Introduction

There are four different cases of chloride flow to consider:

1: *Diffusion of chloride* through uncracked concrete. Chlorides are gradually penetrating the concrete from the outer (upstream) surface of the concrete. The process is very slow in concrete of high quality. The maximum chloride concentration is obtained at the outer surface being exposed to the saline water.

2: *Convective flow of chloride caused by capillary transport* of saline water through uncracked concrete. The process might be rapid in concrete of average quality used in thin structural members. The chlorides are deposited, and enriched, at the inner (downstream) surface of the concrete where the highest chloride concentration in the member is obtained.

3: *Convective flow caused by water transport under an hydraulic head* through uncracked concrete. This flow is superimposed on the capillary flow and gives the same type of "chloride load" on the structure.

4: *Convective flow in through cracks*, the flow being caused by capillary action and superimposed hydraulic head. The chlorides are deposited at the inner surface where a chloride enrichment occurs. The main portion of the crack is exposed to a constant chloride concentration which is equal to the outer concentration in sea water.

The four different transport mechanisms will be discussed below. It will be shown, that only the 4:th mechanism -flow through cracks- is actually of any great danger in thick concrete members of high concrete quality;  $w/c \leq 0,40$ . Therefore, through cracking must be avoided or a tight membrane must applied, either on the upstream surface, or on the downstream surface. In the first case, the whole concrete will gradually dry to a condition that corresponds to the climate inside the tunnel. In the latter case, the concrete will stay water-filled and contain the same chloride concentration as in the surrounding sea water. Another possibility is to inject the cracks so that saline water cannot penetrate to the downstream surface making salt accumulation impossible.

## 2. Mechanism 1: Diffusion

The chloride diffusivity of a virgin uncracked concrete with a water/cement ratio of 0,40 is of the order  $5 \cdot 10^{-12}$  m<sup>2</sup>/s, or lower, when determined in the laboratory before exposure; Sandberg /1993/. In a concrete, that has been exposed to sea water for some years, the chloride diffusivity is very much reduced. This has been found in Norway by Helland /1994/ and in Sweden in the research program "Marine Concrete Structures". The Norwegian results are shown in Fig 1. Concrete cylinders were taken out of structures, that had been immersed in the North Sea for many years. The true effective diffusivity  $D_{\text{eff}}(t)$  estimated from the chloride profile of the concrete exposed during  $t$  days was investigated. On a non-chloride contaminated slice, taken from the other end of the same cylinders, a so-called bulk diffusion test was performed. From the chloride profile obtained in the labtest, the bulk diffusivity  $D_{\text{b,d}}$  was obtained. A linear regression made for the relation between the two diffusivities gives:

$$D_{\text{eff}}(t) = D_{\text{b,d}} \cdot (28/t)^{0,64} \quad (1)$$

This means that the real diffusivity in a 10 year old concrete is on average only 4 % of the bulk diffusivity of the virgin concrete.

In Fig 2, results from the Swedish field test are shown; Sandberg /1994/. The trend is the same as in the Norwegian investigation. The real diffusivity after 1400 days is only

$0,5 \cdot 10^{-12} \text{ m}^2/\text{s}$  which is only 6 % of the diffusivity, that was determined after 35 days;  $8 \cdot 10^{-12} \text{ m}^2/\text{s}$ . This is about the same result as was found in the Norwegian study. The reason for this big reduction in diffusivity in sea water is not clarified. It might depend on chemical reactions between sea water and cement paste, reducing the diffusivity, and/or increasing the relation between free and bound chloride. Another explanation is, that the concrete is not fully water saturated in the real structure (e.g. see Fig 6 and 7) which means that diffusion is more slow than in the saturated condition.

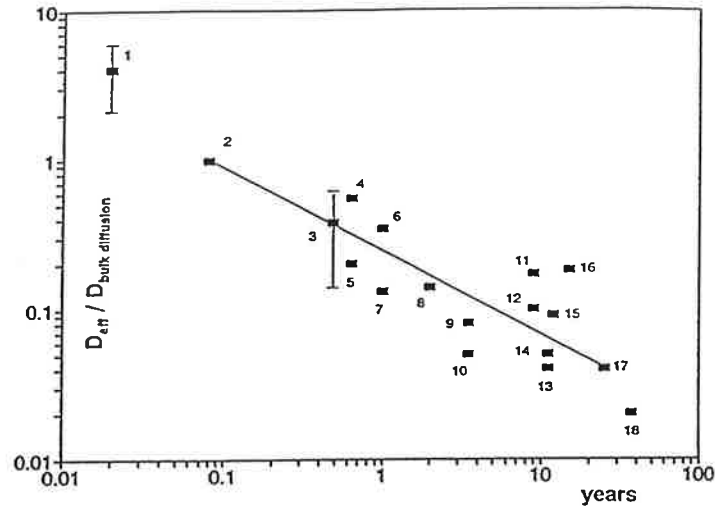

Fig 1: The effective chloride diffusivity in concrete exposed to sea water for long time, versus the diffusivity determined on the virgin concrete. Many concretes with different mix proportions. Helland /1994/.

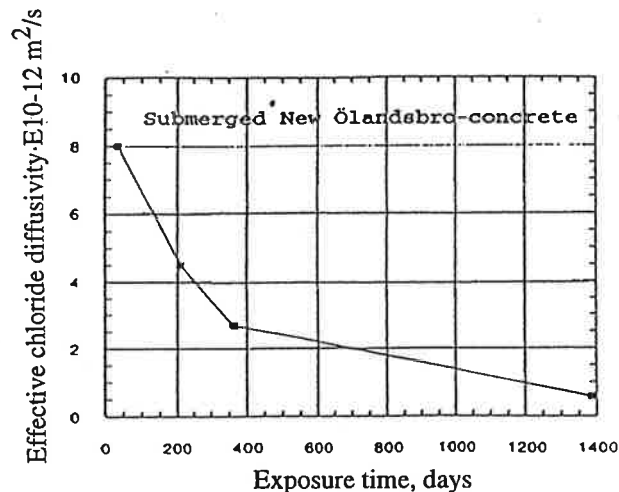

Fig 2: The effective chloride diffusivity in a concrete used for repair of the Öland bridge, and exposed to sea water during 1400 days, versus the diffusivity of the virgin concrete. Pure portland cement  $w/c=0,40$ . Sandberg /1994/.

Almost all the concretes in the Norwegian field test were made with pure Portland cement. Such concrete has the ability of considerable self healing of cracks and minor defects. It is not sure, that the same good prognosis, with regard to chloride diffusivity, is also valid for concrete containing large amounts of mineral admixtures such as slag, fly ash, or silica fume.

With such low chloride diffusivities in sea water, as those found in the Swedish investigation for concretes with the water/cement ratio 0,40, with or without 5 % of silica fume, the penetration depth of chloride in a tunnel in sea water will be very low even after 100 years. This will be shown by an example. The following *pessimistic assumptions* are made:

- 1: The diffusivity is  $5 \cdot 10^{-12}$  m<sup>2</sup>/s. No decrease is assumed to take place during the exposure time.
- 2: The threshold concentration of *free* chloride is assumed to be determined by the following relation; Hausmann /1967/:

$$[\text{Cl}^-]_{\text{thr}}/[\text{OH}^-] = 0,6 \quad (2)$$

- 3: The *free* chloride concentration at the concrete surface is assumed to be twice as high as in the surrounding sea water.
- 4: The chloride concentration of sea water is assumed to be 0,016 kg/kg = 0,46 mole/litre, which is what can be found at the Swedish west coast.
- 5: The cement is assumed to be of low-alkali type with the Na-equivalent 0,5 %. All alkali is assumed to go into solution.

The cement content is 450 kg/m<sup>3</sup>, and the water/cement ratio is 0,40. Then, the water-saturated porosity is about 11 % or 110 litres/m<sup>3</sup>. The molar weight of sodium is 0,023 kg/mole. The OH-concentration, therefore, is:

$$[\text{OH}^-] = (450 \cdot 0,005)/(110 \cdot 0,023) = 0,89 \text{ mole/litre}$$

Thus, the threshold free chloride concentration is:

$$[\text{Cl}^-]_{\text{thr}} = 0,6 \cdot 0,89 = 0,53 \text{ mol/litre}$$

According to the assumption, the surface concentration is:

$$[\text{Cl}^-]_{\text{surface}} = 2 \cdot 0,46 = 0,92 \text{ mole/litre}$$

Then, the solution of Fick's law gives the following penetration depth  $x_{\text{thr}}$  of the threshold concentration after 100 years:

$$x_{\text{thr}} = 0,099 \text{ m} = 99 \text{ mm}$$

This is a big penetration but no corrosion will start in the reinforcement in the upstream surface, due to the lack of oxygen for driving the corrosion process. The threshold concentration will not reach the bars in the downstream surface during 100 years of exposure.

With somewhat more realistic assumptions, the penetration depth should have been much smaller. So for instance, a reduction in the diffusivity by a factor 5, which is reasonable, would reduce the depth of initiation of corrosion after 100 years to 44 mm.

Late results from a Swedish investigation indicate, that the threshold concentration in dense concrete is much bigger than that given by eq (2). According to Pettersson /1994/ a free chloride concentration as high as 40 g/litre or 1,14 mole/litre might be required when the water/cement ratio is 0,40, and the cement is of low-alkali type; see Fig 3. This in fact means, that sea water is not sufficiently saline to cause corrosion, unless the chlorides are accumulated by wetting/drying cycles. Such are not relevant for a submerged tunnel.

**Conclusion:** Corrosion due to diffusion will not be a big problem in thick concrete members of high concrete quality;  $w/c \leq 0,40$ .

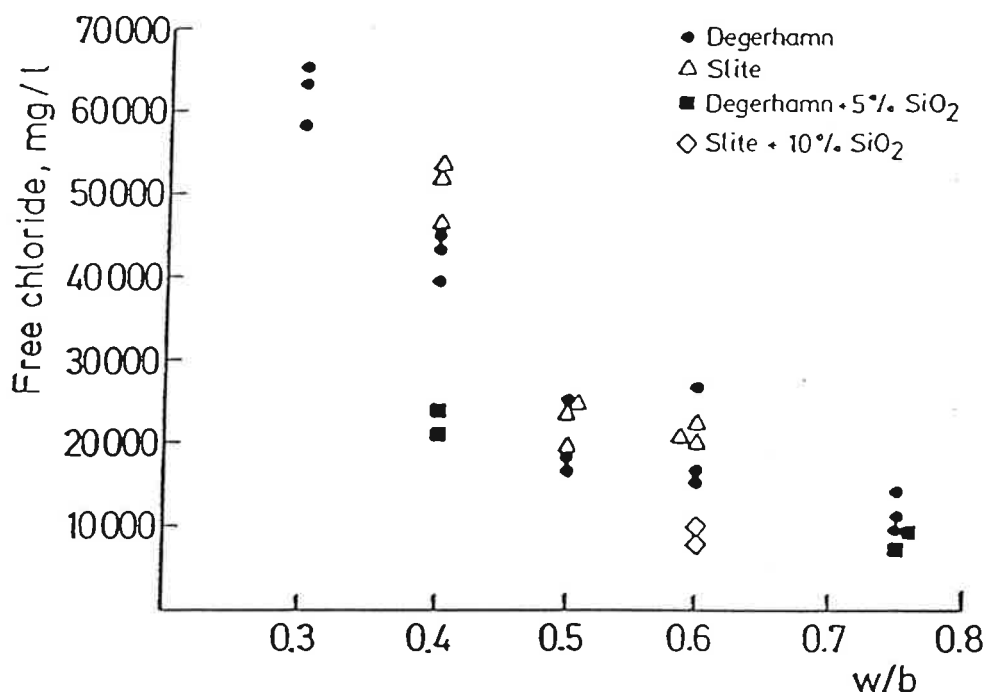

Fig 3: The threshold chloride concentration for start of reinforcement corrosion. Different water/binder ratios (w/b), two different types of portland cement, 0 %, 5 % or 10 % of silica fume. Pettersson /1994/. (The chemical characteristics of the cements are: *Degerhamn*: C<sub>3</sub>A=2%, NaO<sub>eq</sub>=0,5%. *Slite*: C<sub>3</sub>A=8%, NaO<sub>eq</sub>=1,1%)

### 3. Mechanism 2: Convective flow without hydraulic head

#### 3.1 Theory

The chloride flow cannot be more rapid than water flow. The water flow through concrete has been studied in long-term experiments performed by Hedenblad /1993/. In these experiments, concrete and cement mortar specimens were exposed during 5 years to a constant climate of 33% RH at the top surface, and free, liquid water at the bottom surface. The 33 % RH was obtained by a saturated MgCl<sub>2</sub>-solution contained in a vessel placed at the top surface. The four vertical surfaces of the specimens were moisture sealed by aluminum foil and epoxy, so that the moisture flow became unidirectional; from the bottom towards the top surface. The exposed surface was 0,2 m-0,2 m = 0,04 m<sup>2</sup> and the specimen height was either 0,063 m or 0,100 m or 0,150 m. The moisture gradient across the specimen height was monitored by capacitive RH-gauges, which were calibrated before and after each measurement. The gauges were inserted in holes in the specimen. The experimental set-up is shown in Fig 4. The moisture flow was measured by weighing the salt cup at the top chamber at regular intervals.

The experiment resembles exactly the case where water is flowing by capillary action through a concrete during steady state conditions, such as through the roof, or the walls, of the submerged tunnel.



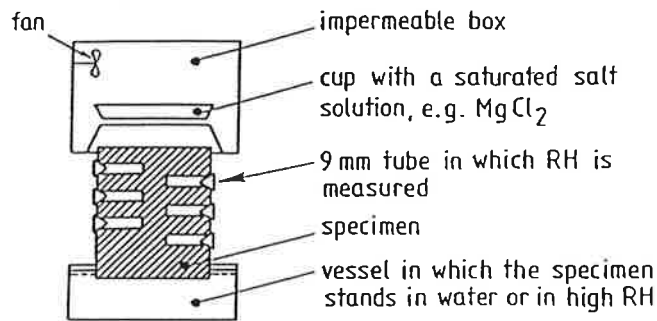

Fig 4: The test used for determination of the long-term transport of water through concrete with one surface placed in free water and the other at 33 % RH. Hedenblad /1993/.

Steady state was reached after a couple of years of exposure time. An example of this can be seen in Fig 5. The RH-profile is never linear, not even at steady state, which reflects the fact that the diffusivity of water is a function of the moisture condition. The flow is described by:

$$g = -\delta(\psi) \cdot d\psi/dx \quad (3)$$

Where

- $g$  the moisture flux [ $kg/(m^2 \cdot s)$ ]
- $\delta(\psi)$  the moisture diffusivity with  $\psi$  as driving potential
- $\psi$  the driving potential (moisture content, or vapour pressure, or vapour content, or RH)

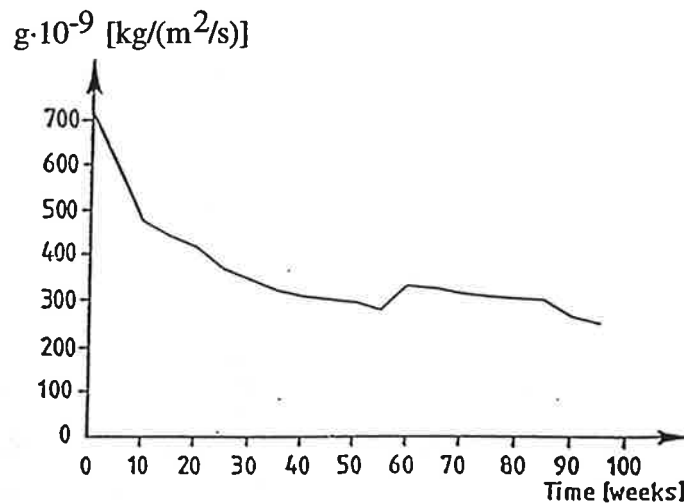

Fig 5: An example of the moisture flux through a concrete specimen as function of the exposure time. Steady state is reached after about 2 years. Hedenblad /1994/.

Moisture profiles after 5 years for cement mortars with the water/cement ratio 0,40 are shown in Fig 6 and 7. The relative humidity is a bit below 100 % at the bottom surface, despite the fact that the surface is placed in water. The reason is the lowered vapour pressure in the pore water caused by soluble salts in the concrete. The general shape of the moisture profiles were almost the same for concretes with the same water cement ratio, independent of the specimen height.

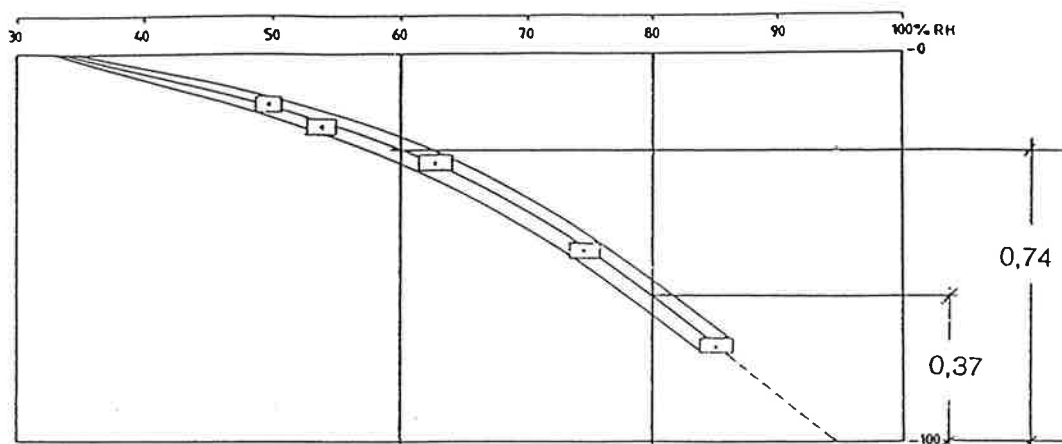

Fig 6: The RH- profile across a 10 cm thick concrete specimen tested according to Fig 4; w/c-ratio 0,40. The exposure time is 5 years. Hedenblad /1993/.

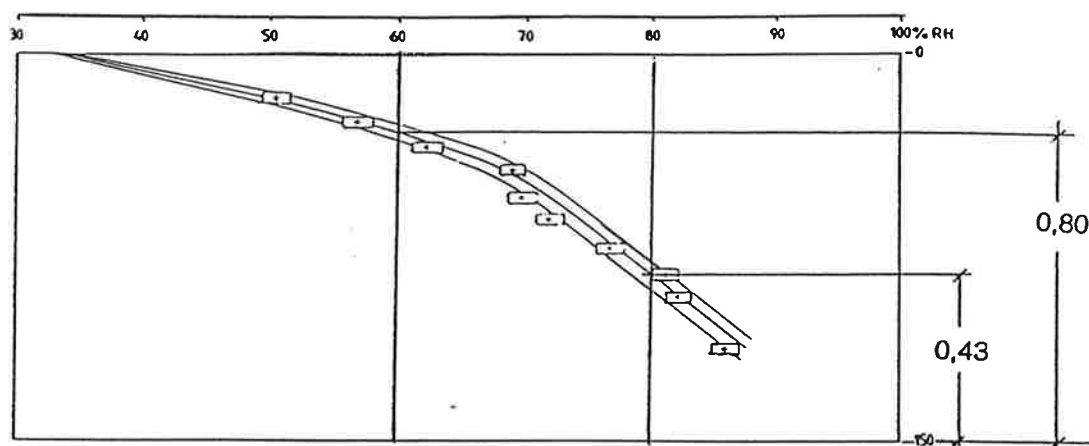

Fig 7: The RH-profile across a 15 cm thick concrete specimen tested according to Fig 4. w/c-ratio 0,40. The exposure time is 5 years. Hedenblad /1994/.

The shape of the moisture profiles (see Fig 6 and 7) indicates that moisture migration through a concrete with low water cement ratio is partly a *normal diffusion process* and not a flow of bulk water.

The moisture flux at steady state was determined both for cement mortar and concrete. It is tabulated in Table 1.

Table 1: The measured moisture flux at steady state in specimens with the water/cement ratio 0,40, and with one side in free water, and the other in 33 % RH; Hedenblad /1993/.

Type	Thickness (m)	Flux ( $\text{kg}/\text{m}^2\cdot\text{s}$ )	
		After 3 years	After 5 years
Concrete	0,100	$2,08 \cdot 10^{-8}$	$2,03 \cdot 10^{-8}$
	0,150	$2,05 \cdot 10^{-8}$	$1,68 \cdot 10^{-8}$
Mortar	0,100	$1,65 \cdot 10^{-8}$	$1,50 \cdot 10^{-8}$
	0,150	$1,74 \cdot 10^{-8}$	$1,24 \cdot 10^{-8}$

Rather small changes in the moisture flux occurs after 3 years indicating, that almost total steady state conditions are reached already after 3 years.

As long as steady state prevails, the moisture flux for any other thickness, and any other outer surface conditions, can be calculated from the measured moisture profiles in Hedenblad's experiments. At steady state for flow across a concrete member of thickness  $H$ , with the constant driving potentials  $\psi_1$  and  $\psi_2$  (or relative humidities  $\Phi_1$  and  $\Phi_2$ ) at the boundaries, the moisture flux is described by:

$$g \cdot H = \int_{\psi_2}^{\psi_1} d(\psi) \cdot d\psi = \int_{\Phi_2}^{\Phi_1} d(\Phi) \cdot d\Phi \quad (4)$$

Where

$g$	the moisture flux [ $\text{kg}/(\text{m}^2 \cdot \text{s})$ ]
$H$	the thickness of the concrete member (m)
$\Phi$	the relative humidity
$\psi_1; \psi_2$	the values of $\psi$ at the two borders of the concrete member
$\Phi_1; \Phi_2$	the values of $\Phi$ at the two borders of the concrete member

Thus, in order to calculate the flux across a member with the thickness  $H$ , located between the relative humidities  $\Phi_1$  and  $\Phi_2$ , the following relation is used; see also Fig 8:

$$g = g_{\text{test}} \cdot H_{\Phi_1; \Phi_2} / H \quad (5)$$

Where

$g$	the actual flux searched for [ $\text{kg}/(\text{m}^2 \cdot \text{s})$ ]
$g_{\text{test}}$	the measured flux during the test [ $\text{kg}/(\text{m}^2 \cdot \text{s})$ ]
$H$	the actual thickness of the concrete member (m)
$H_{\Phi_1; \Phi_2}$	the thickness of the part of the <i>test specimen</i> which is located between the RH-levels $\Phi_1$ and $\Phi_2$

This means that the moisture flux at steady state is inversely proportional to the thickness of the member, which is of course a trivial statement.

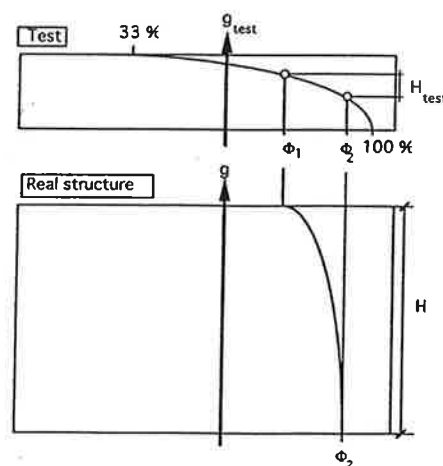

Fig 8: Illustration of eq (5).

### 3.2 Chloride penetration and enrichment in the submerged tunnel

The water transport during 100 years of exposure is calculated under the assumption that the 5-year fluxes listed in Table 1 are valid also for very long times of exposure.

Two different cases are treated. They depend on different assumptions regarding the relative humidity of the air inside the tunnel.

**Assumption 1:** The outer surface is exposed to free water (100 % RH). The inner surface is exposed to an average RH, which is equal to the average RH of outdoor air in Sweden. This is about 80 %. Then, according to the following background information, (i) the moisture profiles in Fig 6 and 7, (ii) the moisture flux through the test specimen of thickness  $H_{\text{test}}$  listed in Table 1, (iii) the use of eq (5) for transforming the specimen to the full scale structure, the flux of water through the tunnel wall at steady state can be calculated.

Fig 6:  $H_{\text{test}} = 0,1$  m: The thickness  $H_{\phi_1, \phi_2} = 0,37 \cdot H_{\text{test}} = 0,37 \cdot 0,1 = 0,037$  m

Fig 7:  $H_{\text{test}} = 0,15$  m: The thickness  $H_{\phi_1, \phi_2} = 0,43 \cdot 0,15 = 0,065$  m

The flux through *concrete* is:

$H_{\text{test}} = 0,10$  m:

$$g = 0,037 \cdot 2,03 \cdot 10^{-8} / H = 0,75 \cdot 10^{-9} / H \quad \text{kg}/(\text{m}^2 \cdot \text{s})$$

$H_{\text{test}} = 0,15$  m:

$$g = 0,065 \cdot 1,68 \cdot 10^{-8} / H = 1,09 \cdot 10^{-9} / H \quad \text{kg}/(\text{m}^2 \cdot \text{s})$$

The flux through *cement mortar* is:

$H_{\text{test}} = 0,10$  m:

$$g = 0,037 \cdot 1,50 \cdot 10^{-8} / H = 0,56 \cdot 10^{-9} / H \quad \text{kg}/(\text{m}^2 \cdot \text{s})$$

$H_{\text{test}} = 0,15$  m:

$$g = 0,065 \cdot 1,24 \cdot 10^{-8} / H = 0,81 \cdot 10^{-9} / H \quad \text{kg}/(\text{m}^2 \cdot \text{s})$$

The flux through concrete is a bit higher than the flux through cement mortar, which might depend on the effect of interfaces between coarse aggregate and cement paste. The maximum value is used for the further calculations; i.e.:

$$g = 1,1 \cdot 10^{-9} / H \quad \text{kg}/(\text{m}^2 \cdot \text{s})$$

<sup>1)</sup> According to Hedenblad /1993/, there seems to be a size dependency on moisture diffusivity. The following relation seems to be valid:

$$\delta_H = \delta_0 \cdot \{H/H_0\}^{0,4}$$

Where,  $\delta_H$  is the diffusivity at the specimen thickness  $H$ , and  $\delta_0$  is the diffusivity at the specimen thickness  $H_0$ . In the actual case, the water flow should evidently be described by:

$$g = \{1,1 \cdot 10^{-9} / H\} \cdot \{H/0,15\}^{0,4}$$

For 1 m thick concrete, the water flow should therefore increase from  $1,1 \cdot 10^{-9}$  kg/(m<sup>2</sup>·s), when no consideration is taken to the thickness, to  $2,3 \cdot 10^{-9}$  kg/(m<sup>2</sup>·s), when the size effect is considered. The reason for this size dependency is not clarified. Eventually, it depends on non-equilibrium conditions for the thicker specimens. If this is the case, a correction for thickness shall not be made. Therefore, in the following, uncorrected values are used.

*Concrete thickness 0,5 m*

Then, assuming the concrete thickness in the tunnel is  $H=0,5$  m, the total water transport during 100 years is:

$$G = (1,1 \cdot 10^{-9}/0,5) \cdot 3600 \cdot 24 \cdot 365 \cdot 100 = 6,9 \text{ kg/m}^2$$

This means that the concrete can be regarded almost completely watertight.

Since the water transport due to capillarity occurs as a diffusion and not as bulk water flow, it is not likely that the chloride transport occurs as convective flow. Even if convective flow is assumed, the maximum amount of chlorides, that are transported to the inner surface of the concrete is only:

$$G_{cl} = G \cdot \{Cl^-\} \quad (6)$$

Where

$G_{cl}$  the amount of water transported during 100 years ( $\text{kg/m}^2$ )

$\{Cl^-\}$  the chloride concentration of sea water ( $\text{kg/kg}$ )

$\{Cl^-\}$  for sea water around the Swedish coast is maximum  $0,016$   $\text{kg/kg}$  (the salt concentration of North Sea water). Thus the maximum amount of chlorides transported is:

$$G_{cl} \leq 6,9 \cdot 0,016 = 0,110 \text{ kg/m}^2$$

This amount of chlorides is assumed to accumulate evenly in the concrete cover, which is supposed to be  $50$  mm. The cement content of the concrete is assumed to be  $450$   $\text{kg/m}^3$ . Thus, the average chloride concentration in % of the cement content is:

$$c_{Cl^-} = [0,110/0,05 \cdot 450] \cdot 100 = 0,49 \text{ \% of the cement weight.}$$

This chloride content is so low, that the risk of reinforcement corrosion, due to chloride convection through uncracked concrete, is small. This can be easily shown by utilizing the assumptions in paragraph 2 above. The average chloride concentration in the pore water in the cover of a concrete with the porosity  $11$  % is  $0,11/0,05 \cdot 110 = 0,020$   $\text{kg/litre}$  or  $0,57$  mole per litre. This is about the same value as the rather pessimistic value selected in paragraph 2 for the threshold concentration in the actual type of concrete;  $0,53$  mole/litre. It is much lower than the threshold value found experimentally by Pettersson /1994/; see Fig 3.

*Concrete thickness 1 m*

The chloride concentration is inversely proportional to the concrete thickness. Thus, if the thickness is  $1$  m the chloride concentration is only  $0,25$  % of the cement weight.

**Assumption 2:** The outer surface is exposed to free water ( $100$  % RH). The inner surface is exposed to a dryer climate than the outer due to heating of the air by the traffic or due to direct heating of the ventilation air. An average RH of  $60$  % is assumed. Then the thickness  $H_{\phi_1; \phi_2}$  is:

$$\text{Fig 6: } H_{\text{test}} = 0,1 \text{ m: The thickness } H_{\phi_1; \phi_2} = 0,74 \cdot H_{\text{test}} = 0,74 \cdot 0,1 = 0,074 \text{ m}$$

$$\text{Fig 7: } H_{\text{test}} = 0,15 \text{ m: The thickness } H_{\phi_1; \phi_2} = 0,80 \cdot H_{\text{test}} = 0,80 \cdot 0,15 = 0,12 \text{ m}$$

The flux through *concrete* is:

$$H_{\text{test}} = 0,10 \text{ m:}$$

$$g = 0,074 \cdot 2,03 \cdot 10^{-8} / H = 1,50 \cdot 10^{-9} \text{ kg/(m}^2 \cdot \text{s)}$$

$$H_{\text{test}} = 0,15 \text{ m:}$$

$$g = 0,12 \cdot 1,68 \cdot 10^{-8} / H = 2,02 \cdot 10^{-9} / H \text{ kg/(m}^2 \cdot \text{s)}$$

The flux through *cement mortar* is:

$$H_{\text{test}} = 0,10 \text{ m:}$$

$$g = 0,074 \cdot 1,50 \cdot 10^{-8} / H = 1,11 \cdot 10^{-9} / H \text{ kg/(m}^2 \cdot \text{s)}$$

$$H_{\text{test}} = 0,15 \text{ m:}$$

$$g = 0,12 \cdot 1,24 \cdot 10^{-8} / H = 1,49 \cdot 10^{-9} / H \text{ kg/(m}^2 \cdot \text{s)}$$

The maximum value is used for the further calculations; i.e.:

$$g = 2 \cdot 10^{-9} / H \text{ kg/(m}^2 \cdot \text{s)}^2$$

The total moisture flow through the concrete during 100 years and the maximum average chloride concentration within the inner concrete cover is obtained assuming the same conditions as for assumption 1. The total moisture flow during 100 years is:

*Thickness 0,5 m:*

$$G = 12,6 \text{ kg/m}^2$$

$$G_{\text{Cl}} = 0,20 \text{ kg/m}^2$$

$c_{\text{Cl}}$  = 0,89 % of the cement weight.

This concentration is so low, that it hardly causes corrosion; c.f the calculation above. Besides, the calculated chloride concentration is an *average value* over the whole thickness of the concrete cover. In reality, the major part of the chloride accumulation, if any, occurs in the outmost centimeters, where there are no reinforcement bars.

*Thickness 1m:*

All figures above for the thickness 0,5 m are reduced by 50 %. Thus:

$c_{\text{Cl}}$  = 0,45 % of the cement weight.

This is the same order of size as for 80% RH and 0,5 m thickness. It will not cause corrosion.

**Conclusions:** The calculations show, that the chloride accumulation due to convective flow through the concrete is so marginal, that it will not cause corrosion provided the concrete member is thick and made of concrete with high quality;  $w/c \leq 0,40$ . The chloride accumulation is small also when the climate inside the tunnel is rather dry.

---

<sup>2</sup> See Footnote 1

#### 4. Mechanism 3: Convective flow with hydraulic head

A hydraulic head will theoretically increase the flow of water through the concrete. This effect is however small, which will be shown below.

Pure capillarity is caused by suction due to curved water menisci at the downstream surface. Those menisci cause an under-pressure (a suction) in the pore water. The total driving pressure for water flow under combined capillarity and hydraulic head is:

$$P = P_{\text{cap}} + P_{\text{h.h.}} \quad (7)$$

Where

$P_{\text{cap}}$  the capillary suction (Pa)  
 $P_{\text{h.h.}}$  The pressure caused by the hydraulic head (Pa)

The capillary suction is determined by the relative humidity at the downstream surface. It is described by Kelvin's law for capillary condensation:

$$P_{\text{cap}} = -\ln(\Phi) \cdot R \cdot T / v_s \quad (8)$$

Where

$\Phi$  the relative humidity  
 $R$  the gas constant (8314 j/kmole)  
 $T$  the absolute temperature (K)  
 $v_s$  the molar volume of water (0,018 m<sup>3</sup>/kmole)

For 10°C the following relation is valid:

$$P_{\text{cap}} = -1,31 \cdot 10^8 \cdot \ln(\Phi) \quad (9)$$

The pressure due to the hydraulic head is:

$$P_{\text{h.h.}} = \gamma \cdot g \cdot h \quad (10)$$

Where

$\gamma$  the density of water (1000 kg/m<sup>3</sup>)  
 $g$  the gravitation constant (9,81 m/s<sup>2</sup>)  
 $h$  the hydraulic head (m)

The maximum hydraulic head is assumed to be 30 m. Then the following relation is valid:

$$P_{\text{h.h.}} = 3 \cdot 10^5 \text{ Pa}$$

The relation between the two pressures obviously depend on the relative humidity at the downstream surface. The same two cases are treated as for pure capillary flow treated in paragraph 3.

**Assumption 1:**  $\Phi=0,80$  (80 % RH)

$$P_{\text{h.h.}}/P_{\text{cap}} = 3 \cdot 10^5 / 2,9 \cdot 10^7 = 0,010$$

**Assumption 2:**  $\Phi=0,60$  (60 % RH)

$$P_{h,h}/P_{cap}=3 \cdot 10^5/6,7 \cdot 10^7 = 0,0045$$

*Conclusions:* The calculations show that the hydraulic head gives a very small contribution to the moisture flow and, therefore, it can be neglected for uncracked concrete. <sup>3)</sup>

## 5. Mechanism 4: Convective flow through cracks

### 5.1 Crack types

One can distinguish three types of cracks; see Fig 9:

Crack 1: Cracks throughout the entire concrete thickness; e.g cracks caused by *thermal stresses* during the production phase, due to outer constraint.

Crack 2: Cracks through the upstream portion of the concrete only. Such cracks are most probably caused by *outer load*.

Crack 3: Cracks through the downstream portion of the concrete. Such cracks are most probably caused by *outer load and/or by shrinkage*.

Only cracks of type 1 will cause large troubles with regard to corrosion, as will be seen below.

It must be observed, that cracks are often gradually healed due to the filling by hydration products, calcite etc. Therefore, the flow through the cracks will in most cases be the highest when the concrete is young. This self-healing effect might be considerably lower in concrete containing large amounts of mineral admixtures such as fly ash, silica fume or ground granulated blast furnace slag.

### 5.2 Cracks of type 1

The following relation is valid for flow through a slit with ideally smooth walls and completely straight:

$$v = P \cdot W^3 \cdot L / (12 \cdot H \cdot \eta) \quad (11)$$

Where

v	the rate of volume flow (m <sup>3</sup> /s)
L	the crack length (m)
P	the pressure causing the flow (Pa)
W	the crack width (m)
H	the crack length parallel to the flow; the concrete thickness (m)
$\eta$	the viscosity of the fluid (Ns/m <sup>2</sup> ). (0,0014 Ns/m <sup>2</sup> for water at +10°C).

<sup>3)</sup> A somewhat more stringent treatment of combined convective and diffusive moisture flow through a submerged tunnel has been performed in Tuutti /1994/. The result is similar to what has been presented above. A calculation based on permeability data for concrete under water pressure shows, that it takes about 100 years for the salt water front to penetrate a 1 m thick concrete exposed to an outer water pressure of 30m. Thus, the inner reinforcement will not "feel" the salt water until almost 100 years have passed.



Let us assume, that the concrete thickness is 0,5 m, and that the hydraulic head corresponds to 30 m of water pressure. Then, the following relation is valid for the flow through 1 m of crack length:

$$v = 3 \cdot 10^5 \cdot W^3 \cdot 1 / (12 \cdot 0,5 \cdot 0,0014) = 3,6 \cdot 10^7 \cdot W^3 \quad (11a)$$

100 years corresponds to  $3,15 \cdot 10^9$  seconds. Then, the total flow V of water during 100 years is:

$$V = 1,13 \cdot 10^{17} \cdot W^3 \text{ m}^3 \text{ or } 1,13 \cdot 10^{20} \cdot W^3 \text{ kg}$$

The flow through cracks of different size during 100 years is shown in Table 2:

Table 2: The total water flow through ideal cracks during 100 years

W (mm)	W (mm)	Flow (kg)
0,2	200	$9 \cdot 10^8$
0,1	100	$1,13 \cdot 10^8$
0,05	50	$1,41 \cdot 10^7$
0,01	10	$1,13 \cdot 10^5$
0,001	1	$1,13 \cdot 10^2$

In a real crack, the flow is considerably smaller, due to the roughness of the crack walls, the tortuosity of the crack etc. It is however quite clear, that cracks running through the concrete will lead very large amounts of water, and thereby chlorides through the concrete. This is the case also for very thin cracks, if they are continuous through the entire concrete thickness.

## 5.2 Cracks of type 2

Such cracks end at the upper reinforcement layer, or somewhat below this. This means that there will be an uncracked portion of the concrete with the effective thickness  $H_{\text{eff}}$ . Flow through this part of the concrete will proceed according to the principles described in paragraphs 2, 3 and 4.

The upper reinforcement will immediately be exposed to a constant chloride concentration, that is equal to the concentration of sea water. The risk of corrosion damage in this reinforcement is low due to the lack of oxygen.

At the lower reinforcement, a certain chloride enrichment will occur due to convective flow. This can be calculated by the theory put forward in paragraph 3. The risk of corrosion is small when the concrete is of high quality ( $W/C \leq 0,40$ ), and the thickness  $H_{\text{eff}}$  is sufficiently large.

## 5.3 Cracks of type 3

The upper portion of the concrete is uncracked. The penetration of chlorides occurs as described in paragraph 2. The chloride front will not reach the cracked part of the concrete, unless the effective height  $H_{\text{eff}}$  of uncracked concrete is very low. The risk of corrosion of the reinforcement in the top layer is the same as in the "uncracked case".

Chlorides penetrating by convective flow, if such occurs, which is unlikely in high quality concrete, accumulate in the downstream crack and might cause corrosion. As long as the uncracked thickness  $H_{\text{eff}}$  is big enough, the convection of chlorides is, however, low and will not cause corrosion. The risk can be estimated by the theory put forward in paragraph 3. The total thickness  $H$  of the concrete is simply replaced by the effective thickness  $H_{\text{eff}}$ .

**Conclusions:** Only cracks that run throughout the entire concrete thickness will cause severe problems with reinforcement corrosion. Other cracks, with limited depth will probably not cause corrosion, provided the uncracked portion of the concrete member is thick enough, and the concrete is of high quality;  $w/c \leq 0,40$ .

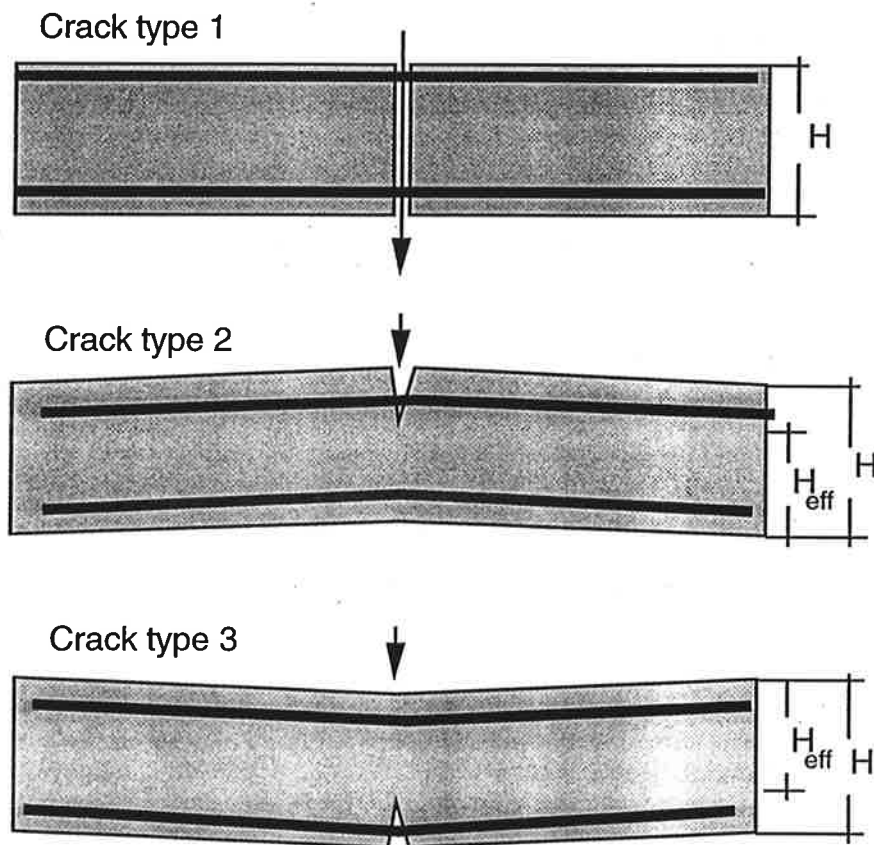

Fig 9: Different types of cracks.

## 6. Suggested general requirements

The analysis performed above, and general considerations concerning the durability of concrete structures, show that it is reasonable to utilize the following general requirements on the quality of a submerged concrete tunnel:

- 1: The water/binder ratio shall not be higher than 0,40 in order to assure low capillarity, low permeability and low diffusivity. Consideration shall be taken to the variation in the water/cement ratio during production. Therefore, a target value of 0,38 is reasonable when the production of concrete mix is under good control.
- 2: The water/binder ratio shall not be lower than 0,35 in order to prevent excessive internal cracking due to self-desiccation, and problems during the production phase. With a target value of 0,38 and a variation of  $\pm 0,02$ , the minimum value is automatically satisfied.
- 3: The uncracked thickness of the roof, the walls and the floor shall not be smaller than 0,5 m in order to reduce the convection of chloride to an acceptable level.
- 4: Through cracks, and cracks to a depth more than 0,5 m from the uncracked surface, shall not be accepted. Such cracks are almost always caused by thermal stresses during the production phase, and can therefore be avoided by measures taken by the contractor; e.g. cooling the fresh mix, cooling the placed concrete, using low heat cement.
- 5: The cement shall be sulfate resistant. This means that a Portland cement shall have a  $C_3A$ -content below 5 % (ASTM-requirement). A slag cement shall have at least 65 % ground granulated slag (70 % according to DIN). Lower slag contents cannot be used, since the high alumina content in slag might decrease the sulfate resistance also when the portland cement-base in the cement is sulfate resistant.

*Note 1:* No requirement is suggested for the minimum amount of  $C_3A$  of the Portland cement. This depends on clear indications from lab- and field studies, that not only  $C_3A$  binds chloride. The ability of a cement to bind chloride also depends, to a high degree, on the amount of  $C_4AF$ . Besides, with the low w/c-ratio required, the chloride diffusivity in the field will be very low also with a cement that is low in  $C_3A$ .

*Note 2:* Fly ash might impair the sulfate resistance of the concrete, due to its own high amount of alumina.

- 6: The cement shall be of low-alkali type. This means, that the equivalent  $Na_2O$ -content shall be below 0,6 %. Besides, the total equivalent  $Na_2O$ -content shall be below 3 kg per  $m^3$  of concrete.
- 7: The maximum amount of mineral admixture to be added to the concrete mix, or to be added to the portland cement at cement manufacture (blended cement), shall be determined on the basis of the effect of the mineral admixture on the alkalinity of the concrete, and the effect on the self-healing capacity; too high dosages of mineral admixtures might severely impair the corrosion protection of the reinforcement. A maximum reduction in the calcium hydroxide content of 25 % after about 3 months hydration seems to be reasonable. This reduction is related to the calcium hydroxide content of a comparable concrete made with pure portland cement.

For silica fume, a general maximum amount of 5% ought to be tolerated. Higher amounts might cause too large reductions in the "base reserv", and internal cracking due to self-desiccation.

- 8: The concrete temperature, during the production phase, shall not exceed +60°C in the interior; preferably, it shall not exceed +50°C. This limitation is based on the reasonable belief that the internal cement paste structure formed at high temperatures is more coarse-porous than is normal cement paste. This will probably influence the chloride diffusivity. Besides, the risk of secondary cement reactions is more or less completely eliminated at these temperatures.
- 9: The concrete cover shall preferably not be smaller than 50 mm and 75 mm at the inner and outer surfaces, respectively. These values are valid for the bar that is closest to the surface. With these big covers, combined with the high quality of the concrete, the risk of corrosion is low.
- 10: The concrete shall not be exposed to sea water until it has a maturity corresponding to that obtained after 14 days of standard curing; i.e. about 5 days of water curing at +20°C followed by about 9 days of curing at normal RH and +20°C.

## References:

- Hausmann D.A: Steel corrosion in concrete. *Materials Protection*, Nov. 1967.
- Hedenblad G: Moisture permeability of mature concrete, cement mortar and cement paste. Div of Building Materials, Lund Institute of Technology, Report TVBM-1014, Lund, 1993.
- Helland S: Chloride penetration into marine structures. Report presented to the RILEM Workshop on "Durability of High Performance Concrete", Vienna February 15-15, 1994. Selmer A.S. Norway, 1994.
- Pettersson K: Unpublished results from an investigation of the threshold chloride concentration for onset of reinforcement corrosion. Swedish Cement and Concrete Research Institute, Stockholm, 1994.
- Sandberg P: Unpublished results from the Swedish project "Marine Concrete Structures". Div of Building Materials, Lund Institute of Technology, 1994.
- Tuutti K: Statement concerning the question of durability of the submersed tunnel, Österleden. Div of Building Materials, Lund Institute of Technology, Report Nr U94.12, Lund 1994.

