



LUND UNIVERSITY

The Effect of Displacement on Air-Diluted Multi-Cylinder HCCI Engine Performance

Hyvönen, Jari; Wilhelmsson, Carl; Johansson, Bengt

Published in:
SAE Technical Papers

2006

[Link to publication](#)

Citation for published version (APA):

Hyvönen, J., Wilhelmsson, C., & Johansson, B. (2006). The Effect of Displacement on Air-Diluted Multi-Cylinder HCCI Engine Performance. In *SAE Technical Papers* SAE. <http://www.sae.org/technical/papers/2006-01-0205>

Total number of authors:

3

General rights

Unless other specific re-use rights are stated the following general rights apply:

Copyright and moral rights for the publications made accessible in the public portal are retained by the authors and/or other copyright owners and it is a condition of accessing publications that users recognise and abide by the legal requirements associated with these rights.

- Users may download and print one copy of any publication from the public portal for the purpose of private study or research.
- You may not further distribute the material or use it for any profit-making activity or commercial gain
- You may freely distribute the URL identifying the publication in the public portal

Read more about Creative commons licenses: <https://creativecommons.org/licenses/>

Take down policy

If you believe that this document breaches copyright please contact us providing details, and we will remove access to the work immediately and investigate your claim.

LUND UNIVERSITY

PO Box 117
221 00 Lund
+46 46-222 00 00

The effect of displacement on air-diluted multi-cylinder HCCI engine performance

Jari Hyvönen

GM Powertrain Sweden / Lund Institute of Technology

Carl Wilhelmsson, Bengt Johansson

Lund Institute of Technology

Copyright © 2006 SAE International

ABSTRACT

The main benefit of HCCI engines compared to SI engines is improved fuel economy. The drawback is the diluted combustion with a substantially smaller operating range if not some kind of supercharging is used. The reasons for the higher brake efficiency in HCCI engines can be summarized in lower pumping losses and higher thermodynamic efficiency, due to higher compression ratio and higher ratio of specific heats if air is used as dilution. In the low load operating range, where HCCI today is mainly used, other parameters as friction losses, and cooling losses have a large impact on the achieved brake efficiency.

To initiate the auto ignition of the in-cylinder charge a certain temperature and pressure have to be reached for a specific fuel. In an engine with high in-cylinder cooling losses the initial charge temperature before compression has to be higher than on an engine with less heat transfer. The heat transfer to the combustion chamber walls is affected by parameters such as area-to-volume ratio and in-cylinder gas motion, i.e. turbulence.

In this paper the performance of three multi-cylinder HCCI engines with different displacements are compared. The engines are a five-cylinder 1.6dm³ VCR engine, a four-cylinder 2.0dm³ engine, and a six-cylinder 11.7dm³ truck engine. All engines are port fuel injected and run with a RON91/MON82 gasoline. Combustion phasing is mainly controlled with inlet air temperature. The engines have about the same indicated efficiency but different brake efficiency. The truck engine has 32.3% brake efficiency at 2bar BMEP, followed by the 2.0dm³ engine with 29.8%, and the 1.6dm³ VCR engine with only 24.4%.

INTRODUCTION

Controlled auto ignition of an air/fuel mixture in an internal combustion engine can be achieved by controlling the temperature and pressure history, the fuel properties, and mixture composition in the cylinder. The

most frequently used acronym for this type of combustion is Homogeneous Charge Compression Ignition (HCCI), which also will be used in this article, despite the fact that the combustion not necessarily is particularly homogeneous or entirely compression ignited. A recent perhaps more accurate acronym Low Temperature Combustion (LTC) has lately started to be used in the combustion engine research community, especially within HCCI or Partly Premixed Combustion concepts with diesel fuel.

Using HCCI combustion in a part of the operating range in both Spark Ignition (SI) and Compression Ignition (CI) engines is regarded as a promising way to further improve the performance of the internal combustion engine. Improved performance in this sense is to obtain higher fuel conversion efficiency for SI engines and lower emissions of NO_x and soot for CI engines. The common knowledge of the HCCI process has increased substantially since the first hot bulb engines in the early twentieth century [1], the description of the ATAC combustion concept for two stroke engines in the seventies [2,3], and description of the main benefits for four stroke engines in the eighties [4,5]. A great number of articles have been published since then, investigating different aspects of HCCI and its variants.

Due to the lack of dilution at high load, HCCI is still dependent on the conventional combustion concepts SI and CI. This also affects the research and development of HCCI engines that have divided into different paths depending on the type of fuel and hardware used, despite the inherent multi fuel capability of HCCI. The main feasible path within gasoline engines today is HCCI achieved by trapped residual gas, direct fuel injection, and moderate compression ratio, limited by the need to keep the benefit-to-cost ratio high. The HCCI test engines used in this article have high compression ratios, use air as dilution, are port fuel injected, and have inlet air temperature as main control parameter.

HCCI engines have higher brake efficiency than conventional SI engines, due to several reasons such as

less pumping losses and higher compression ratio. The base engine design and how HCCI is achieved also affect the performance of the HCCI engine. Higher compression ratio increases friction losses, due to a more robust design, and cooling losses, due to increased area-to-volume ratio [21, 22]. The combustion chamber area-to-volume ratio increases also the volume ratio of boundary layer to bulk gas, affecting the amount of CO and HC from the engine and consequently the combustion efficiency [17]. In this paper the performance of three different sizes of HCCI engines are compared and the differences in brake efficiency are investigated.

EXPERIMENTAL APPARATUS

THE TEST ENGINES

Three different engines are used in the performance comparisons in this paper. The different engines are a five-cylinder 1.6dm³ VCR SI gasoline engine, a four-cylinder 2.0dm³ SI gasoline engine, and a six-cylinder 11.7dm³ truck diesel engine. The 1.6dm³ VCR engine is a modified Saab Variable Compression (SVC) Ratio Engine [6]. The compression ratio span is between 10:1 and 30:1, and the displacement per cylinder is 0.32dm³. To achieve these high compression ratios the pistons were changed and the compression volume minimized. In the tests presented in this paper the compression ratio has been between 20:1 and 29:1. The engine is naturally aspirated and has been used for generating test results in several HCCI publications [7-15]. Some engine specifications can be found in Table 1.

Table 1: SAAB VCR-HCCI engine specifications

Test engine	SAAB VCR HCCI
Displacement	1.598 dm ³ (0.32 dm ³ /cyl)
Number of cylinders	5
Compression Ratio	Adjustable 10–30:1
Bore x Stroke	68mm x 88mm
Exhaust valve open	45°BBDC at 0.15mm lift
Exhaust valve close	7°ATDC at 0.15mm lift
Inlet valve open	7°BTDC at 0.15mm lift
Inlet valve close	34°ABDC at 0.15mm lift
Combustion chamber	Pent roof / 4 valves DOHC

The second engine is a modified Saab turbocharged 175hp engine (model year 2003) based on the General Motors (GM) L850 engine family. This version of the engine has fixed camshafts, Port Fuel Injection (PFI), and a displacement per cylinder of 0.5dm³. The original pistons have been changed in the test engine to increase the compression ratio from 9.5:1 to 18:1. The choice of compression ratio is based on the HCCI tests done with the Saab Variable Compression Ratio engine [7-14] and is also about the same as in the truck engine. The engine has a Variable Nozzle Turbine (VNT) turbocharger to control the amount of dilution if needed. Some L850 HCCI engine specifications can be found in Table 2. A picture of the test bed with the modified L850-engine can also be seen in Figure 1.

Table 2: L850 HCCI engine specifications

Test engine	GM L850 HCCI
Displacement	1.998 dm ³ (0.5 dm ³ /cyl)
Number of cylinders	4
Compression Ratio	Modified 18:1, standard 9.5:1
Bore x Stroke	86mm x 86mm
Exhaust valve open	25°BBDC at 0.15mm lift
Exhaust valve close	13°ATDC at 0.15mm lift
Inlet valve open	4°BTDC at 0.15mm lift
Inlet valve close	20°ABDC at 0.15mm lift
Combustion chamber	Pent roof / 4 valves DOHC

The third engine is a modified Scania D12 turbocharged diesel CI engine and it has also been used for several HCCI publications [e.g. 16]. All of the previous Scania D12 HCCI results are obtained using port fuel injected dual-fuel, e.g. n-heptane and iso-octane, to control the auto ignition properties of the fuel and consequently the combustion phasing. In the tests presented in this paper only a port fuel injected single fuel was used and the combustion phasing was controlled by altering the inlet air temperature. Two different turbochargers were used during the tests. The original turbocharger was used in the 2000rpm tests and a smaller turbocharger in the 1000rpm tests to increase boost pressure with low exhaust gas temperatures. The engine has the original combustion chamber with a bowl in the piston and the compression ratio is 18.1:1. Some Scania D12 engine specifications can be found in Table 3.

Table 3: Scania D12 engine specifications

Test engine	Scania D12
Displacement	11.705 dm ³ (1.951 dm ³ /cyl)
Number of cylinders	6
Compression Ratio	18.1:1
Bore x Stroke	127mm x 154mm
Exhaust valve open	82°BBDC at 0.15mm lift
Exhaust valve close	38°ATDC at 0.15mm lift
Inlet valve open	39°BTDC at 0.15mm lift
Inlet valve close	63°ABDC at 0.15mm lift
Combustion chamber	Bowl-in-piston / 4 valves

The high compression ratio and the unmachined pent roof combustion chamber tolerances cause compression ratio differences between cylinders [19] in both of the SI based engines. These differences are adjusted with washers below the spark plugs. Since HCCI combustion in the test engines is achieved with air as dilution and inlet air heating, a high compression ratio is needed. The inlet air is heated with exhaust gases in both the SI engine cases and with electrical heaters in the Scania D12 engine. The inlet air control system will be presented in the next section. The valve timings are standard except for the inlet valve closing (IVC) timing in the SI engines, which are about 15CAD earlier IVC than standard, to increase the effective compression ratio at

lower engine speeds. The ignition system consists of an in-house made driver together with the original cylinder-individual coils and conventional spark plugs.

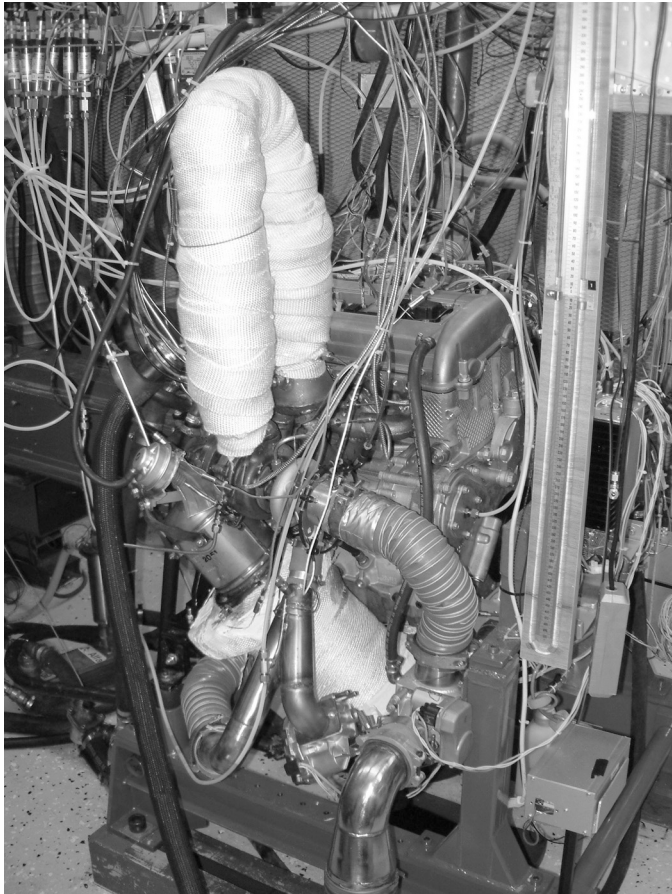

Figure 1: The Saab L850 HCCI test engine

The air supply system to the SI engines and the exhaust system from the SI engines have been modified. A flow-chart of the inlet air and exhaust gas for the L850 HCCI engine is shown in Figure 2. The inlet air and exhaust system in the VCR HCCI engine is in principle the same except the absence of a turbocharger. After the turbocharger compressor the inlet air can be heated in an exhaust-to-inlet air heat exchanger or cooled in a charge air cooler depending on the positions of two throttle valves controlling the air flow. The hot and the cold air are mixed before the the engine. The inlet air temperature is consequently controlled by the two throttle valves and can be used for fast combustion phasing control [9, 11]. The exhaust to inlet air heat exchanger is placed directly after the original three-way catalyst to take advantage of the chemical energy from the unburned hydrocarbons in the exhaust. The exhaust temperature increases about 100°C in the catalyst. Cold start of the engine is performed in conventional Spark Ignition mode to heat up the engine, the catalyst and the heat exchanger. Once heated up both the catalyst and the heat exchanger have some thermal inertia that can be used for HCCI combustion phasing control in e.g. engine transients, mode transfers, or at hot engine startups. The charge air cooler temperature was kept

constant with an external water cooling system during the tests.

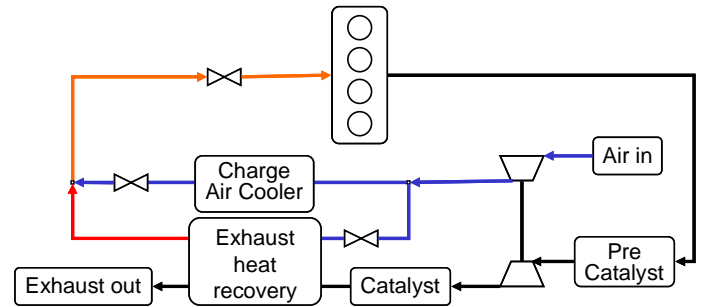

Figure 2: Inlet air and exhaust system

A pre catalyst positioned before the turbocharger turbine was used in some of the L850 HCCI tests to increase the temperature, i.e. sensible energy, in the exhaust before the turbine [15]. In the HCCI tests both catalysts work as oxidizing catalysts since excess air is available.

MEASUREMENT AND ENGINE CONTROL SYSTEM

The engine control system for the SI engines is an in-house developed program at Lund Institute of Technology running on a standard PC with a multi function PCI card NI6052E and a counter PCI card NI6602. The engine control system in the Scania D12 HCCI engine is in principle the same except for some differences in hardware. The engine control system consists of controllers controlling fuel injection, spark ignition, and inlet air throttles. Feedback parameters are cylinder individual combustion phasing, engine load, engine speed, inlet air temperature, and inlet air pressure. Some engine protection functionality, e.g. misfiring, maximum cylinder pressure, maximum rate of pressure rise, etc., are also included in the control system. Combustion phasing, which is the main control parameter, is calculated as the crank angle of 50% burnt (CA50) and controlled mainly by the inlet air temperature, but also to some extent with cylinder individual air-fuel ratio and spark assistance [11,12,13]. The CA50 is calculated on-line based on a simple heat release analysis.

Cylinder pressure is measured in all cylinders with water cooled Kistler 6043A pressure sensors, charge amplified with Kistler 5011B, and sampled with a fast data acquisition processor board, DAP 5400a from Microstar Laboratories. An incremental encoder 520 from Leine & Linde is used for triggering. The sampling speed is five samples per Crank Angle Degree (CAD) and cylinder at all engine speeds up to 5000rpm.

The regulated exhaust emissions are measured with exhaust gas measurement equipment from Boo instrument. Boo instrument uses analyzers from different suppliers. O₂ and CO₂ are measured with a Maihak UNOR611 analyzer. CO₂ is measured with a Non-Dispersive Infrared (NDIR) technology and O₂ in a paramagnetic measuring cell using the paramagnetic

property of oxygen. CO is measured with Maihak UNOR610 analyzer also using NDIR technology. NOx (NO+NO2) emissions are measured with an analyzer from ECO Physics, CLD 700 El ht, using a Chemiluminescence Light Detector (CLD) to measure the chemiluminescence from the reaction between NO and ozone (O3). The HC analyzer from JUM Engineering, model 109A, has two Flame Ionization Detectors (FID) to measure both methane and non-methane hydrocarbons. NOx and HC are measured wet. O2, CO, and CO2 are measured dry. The relative air/fuel ratio, lambda, is calculated from the exhaust gas emissions by applying carbon, hydrogen, and oxygen balances to a chemical reaction between HC and air. Lambda is also measured directly with an ETAS LA3 broadband lambda sensor. The lambda sensor works according to the Universal Exhaust Gas Oxygen (UEGO) Sensor principle.

Fuel consumption is measured by weighing. Parameters that are used for control, like inlet air pressure, inlet air temperature, and torque are measured with the multi function PCI card NI6052E from National Instruments. Torque is measured with a torque flange, T10F, from HBM. The sample rate is one tenth of the sample rate for the cylinder pressure. All variables can be saved for post processing, e.g. heat release analysis. Other variables, such as temperatures and pressures of air, exhaust, water, and lubricating oil, are logged with a HP data logger at a rate of approximately 0.33Hz.

TEST PROCEDURE AND FUEL

All measurements are performed in steady state. The results presented are load sweeps from minimum to maximum load. As a comparison to the HCCI tests two results from conventional L850 SI engine load sweeps are added. One of them is with standard compression ratio and the other with the modified compression ratio of 18:1. Engine speed is kept constant at 2000rpm in all load sweeps, except for one of the Scania D12 engine tests which is at 1000rpm. Combustion phasing is controlled by inlet air temperature and cylinder-to-cylinder differences adjusted with cylinder individual fuel amount offsets. At the highest load points the average maximum cylinder pressure is not allowed to be higher than 100bar and the maximum rate of pressure rise is kept below 10bar/CAD in the SI engines. NOx is kept below 15ppm, i.e. corresponding to about 1gNOx/kgFuel.

The same test fuel is used in all of the engines. The fuel is gasoline, U.S. Unleaded Regular, with a RON between 91 and 92, and MON between 81.5 and 82.5. No auxiliary equipment is used on the engines regardless of combustion mode. The VCR and the Scania D12 had the generator and Air Conditioning (A/C) compressor mounted but both are unloaded. The parasitic load from the bearing and hydrodynamic friction in the generator and compressor can be assumed to be negligible when running steady state. The L850 had no generator or A/C-compressor mounted at all. In a vehicle the parasitic load from the auxiliary equipment depends on the running

conditions. For example in a typical mid-size car the vehicle electrical power requirement at 2000rpm corresponds to a load increase of about 0.3bar BMEP.

The analysis of the results has mainly been carried out by using Mean Effective Pressures (MEP) and efficiencies. The definitions of the different MEPs and combustion efficiencies can be found in the appendix and a flow chart of them can also be seen in Figure 3, starting with the supplied fuel amount to the engine as FuelMEP and ending with the brake power out from the engine as BMEP.

$$\eta_{brake} = \eta_{combustion} * \eta_{thermodynamic} * \eta_{mechanical} * \eta_{GasExchange}$$

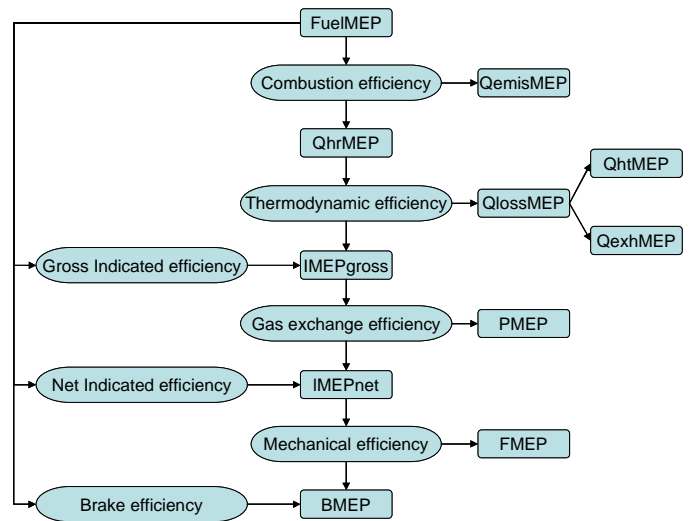

Figure 3: Mean Effective Pressure (MEP) flow chart

RESULTS AND DISCUSSION

BRAKE EFFICIENCY AND COMBUSTION PHASING

In Figure 4 brake efficiency with HCCI combustion is shown for the three different test engines and SI combustion for the L850 engine with two different compression ratios. The Scania D12 engine at 1000rpm has the highest brake efficiency throughout the load range. Second highest has the L850 HCCI engine. The lowest brake efficiency of the HCCI engines is achieved with the VCR HCCI engine. The Scania D12 at 2000rpm is between the L850 HCCI and VCR HCCI up to 3bar BMEP. Above 3bar BMEP it has about the same brake efficiency as the L850 HCCI engine. The brake efficiencies at 2bar BMEP are 32.3% for the Scania D12 at 1000rpm, 29.8% for the L850 HCCI, 26.4% for the Scania D12 at 2000rpm, and 24.4% for the VCR HCCI case. To find out the reason for these differences the different part efficiencies need to be examined.

Both SI cases have lower brake efficiency than the HCCI cases, and with the high compression ratio SI highest. The improvement in brake efficiency from the standard L850 SI engine to the L850 HCCI engine is 54% at 2bar BMEP and 2000rpm. If the effect from higher

compression ratio is neglected the increase in brake efficiency is 35%. The brake efficiency is higher for the high 18:1 compression ratio SI L850 than the standard 9.5:1 compression ratio engine up to 4.5bar BMEP. The reason for this can be seen in Figure 5, where crank angle for 50% burnt, CA50, is shown. The combustion phasing is at MBT timing up to 2bar BMEP in the L850 SI with high compression ratio, but at higher loads the timing is retarded to avoid knock. At 2bar BMEP the high compression ratio SI has 14% higher brake efficiency than the standard. The MBT CA50 timing is about 10°ATDC for both SI cases at 2bar BMEP.

The high compression ratio SI was run up to 6bar BMEP in these tests, but there is no immediate limit to run at even higher loads. At higher load the combustion timing has to be retarded even more, which will increase the exhaust gas temperature. At 6bar BMEP the exhaust gas temperature after the exhaust port is 690°C, see Figure 15. If the exhaust gas temperature increases linearly with load, as between 2 and 6bar BMEP, at least 12bar BMEP, with $\lambda=1$, is possible to achieve before the exhaust gas temperature reaches about 1000°C, which is the limit for contemporary three-way catalysts and turbocharger turbines. A maximum SI load of 12bar BMEP opens up the possibility to use high compression ratio air-diluted HCCI-SI engines instead of low compression ratio exhaust residual HCCI-SI engines. The drawback with high compression ratio SI, compared to low compression ratio, at higher load than 4.5bar BMEP is lower brake efficiency, due to late combustion timing.

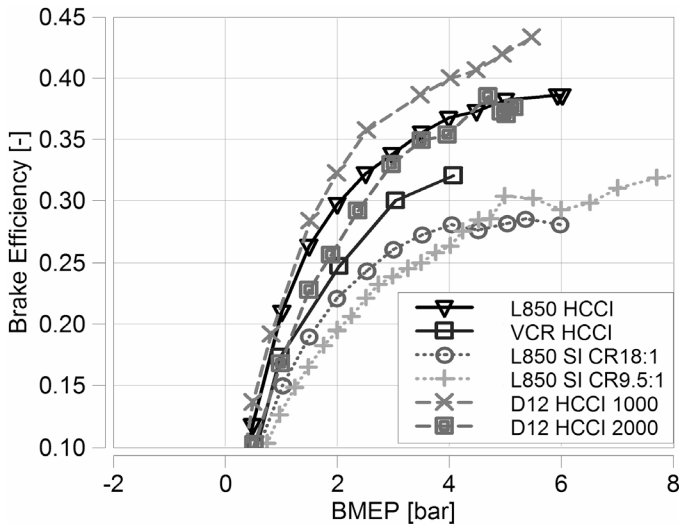

Figure 4: Brake efficiency as function of BMEP at 2000rpm, except for one of the D12 cases where the engine speed is 1000rpm.

The L850 HCCI engine has about the same brake efficiency as the Scania D12 engine at 1000rpm up to 1bar BMEP but lower as load increases. The combustion phasing was adjusted to MBT timing in all of the engines, except for the Scania D12 engine at 1000rpm at the two highest load points, see Figure 5, and for the VCR and L850 engines in some of the lowest load points below

0bar BMEP, where not high enough exhaust heat is available. In the two highest load points in the Scania engine at 1000rpm, inlet air temperature was adjusted as low as possible, i.e. only charge air cooling was used, to retard the combustion phasing as much as possible. The required inlet air temperatures are discussed later in the paper and can be seen in Figure 16. With a later combustion phasing the brake efficiency could have been slightly higher in these two points. The L850 HCCI engine has in its turn higher brake efficiency than the VCR engine in the whole load range. Both compression ratio and combustion phasing were optimized on the VCR engine to give maximum brake efficiency at each load. At 2bar BMEP brake efficiency is 22% higher for the L850 HCCI than the VCR HCCI engine. The reason for these differences in brake efficiency between the engines is investigated in the following sections.

The combustion phasing in all of the HCCI engines at low engine loads are earlier than would be expected to be the optimum in a thermodynamic point of view, see Figure 5. The reason is that also other factors affect the brake efficiency than thermodynamic efficiency and in this case the combustion efficiency has a large effect, discussed in the next section.

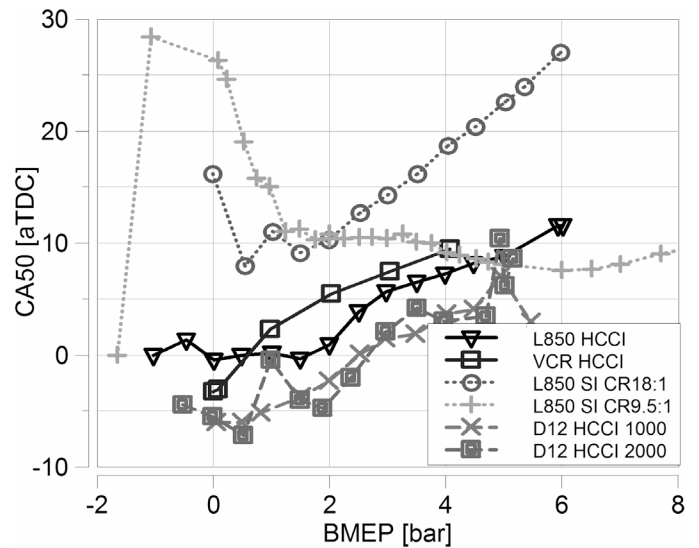

Figure 5: Combustion phasing, CA50, as function of BMEP at 2000rpm, except for one of the D12 cases where the engine speed is 1000rpm.

The maximum rate of pressure rise limit is set to 10bar/CAD in the L850 and the VCR engine. The highest measured rate of pressure rise is 8.6bar/CAD in the VCR engine at maximum load. Hence, the choice of combustion phasing is not restricted by the maximum rate of pressure rise in the L850 or the VCR engines. However, in the Scania D12 engine the maximum rate of pressure rise is above 10bar/CAD above 2bar BMEP in the 2000rpm case and above 4bar BMEP in the 1000rpm case. Despite this combustion phasing is set to MBT timing in all test points, except at the two highest load points in the Scania D12 at 1000rpm case, where MBT timing could not be reached. The highest measured

maximum rate of pressure rise in the Scania D12 is about 20bar/CAD in the 2000rpm case at 5bar BMEP.

COMBUSTION EFFICIENCY

Combustion efficiency, see Figure 6, tells how much of the fuel energy is released in the combustion process and how much is lost to the exhaust as unburned HC and CO. The standard L850 SI engine has the highest combustion efficiency, and all of the high compression ratio engines, with higher cylinder pressures, have lower combustion efficiency due to the unburned hydrocarbons receding in the crevices. At low load all three fixed geometry high compression ratio HCCI cases have poor combustion efficiency due to partially burned cycles, i.e. only partially oxidized due to high air-fuel ratio and low combustion temperatures. In the VCR HCCI case the combustion temperatures, and the combustion efficiency, can be kept higher at low load, due to the higher available compression ratio.

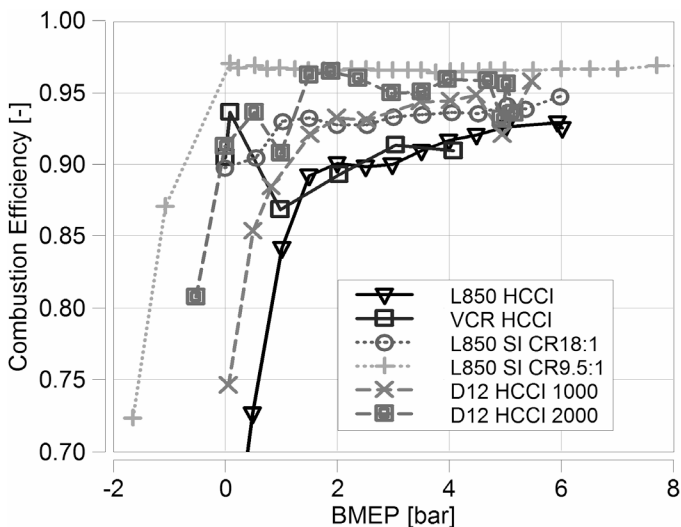

Figure 6: Combustion efficiency as function of BMEP at 2000rpm, except for one of the D12 cases where the engine speed is 1000rpm.

The poor combustion efficiency can also be seen on the combustion instability, i.e. COV IMEP, where the VCR HCCI engine has the lowest COV IMEP at all loads, but especially at loads below 2bar BMEP. Above 1bar BMEP the VCR and the L850 HCCI engine have about the same combustion efficiency, i.e. this is not the reason for the brake efficiency differences between these engines. However, the Scania D12 HCCI has higher combustion efficiency than the smaller HCCI engines above about 1bar BMEP. This is one reason for the higher brake efficiency of the Scania D12 engine at 1000rpm. The Scania D12 at 2000rpm has higher combustion efficiency than the 1000rpm case, but despite that lower brake efficiency. Obviously some of the remaining part efficiencies, discussed in the coming sections, are poor.

At 2bar BMEP the L850 HCCI and VCR HCCI have about 90%, and the Scania D12 about 93% and 96% combustion efficiency at 1000 and 2000rpm respectively.

The reason causing the Scania D12 engine to have higher combustion efficiency through almost the whole load range is the larger combustion chamber. Table 4 shows some comparisons between the engines as: geometric and effective compression ratio, combustion chamber volume and area, area-to-volume ratio, boundary layer volume, etc. The comparison is performed at 2bar BMEP conditions for the VCR-HCCI engine where the compression ratio was 22:1. For comparison the maximum compression ratio of 30:1 is also included. If we assume to have 1mm thick boundary layers the boundary layer volume percentage of the total compression volume is large in the VCR and the L850 HCCI engines. The boundary layer percentage is about 60% for these engines compared to 29% for the larger Scania D12 combustion chamber. At maximum compression ratio with the VCR HCCI engine the boundary layer volume percentage is 81% at TDC, i.e. most of the fuel and most of the oxidation of the fuel takes place in the boundary layer. The lower temperatures in the boundary cause more hydrocarbons and CO to escape the engine and decrease the combustion efficiency. In this respect a lower area-to-volume ratio combustion chamber is preferred.

Table 4: Comparison of the test engines

	VCR 30:1 HCCI	VCR 22:1 HCCI	L850 HCCI	Scania D12
Bore [mm]	68	68	86	127
Stroke [mm]	88	88	86	154
Bore/Stroke-ratio	0.77	0.77	1.00	0.82
Swept volume [cm ³]	320	320	500	1951
CR geometric	30	22	18	18.1
Area/Volume-ratio at TDC [1/mm]	0.81	0.60	0.61	0.29
Boundary layer set [mm]	1	1	1	1
Boundary volume percentage at TDC	81	60	61	29
Crevice volume percentage at TDC	2.1	1.5	1.7	0.9
Compression pressure [bar]	58.3	45	40.5	47.1/52.1
CR effective	17.3	14.3	13.3	14.8/15.3

The combustion efficiency drops rapidly in all HCCI cases, except for the VCR HCCI case, as the load is decreased below about 1bar BMEP. As mentioned earlier combustion efficiency decreases since the air-fuel ratio increases and the amount of partially oxidized cycles increases. To reduce the amount of partial oxidation combustion phasing is advanced early. This is why MBT timing is found earlier than expected in a thermodynamic point of view, where the trade of between expansion work and heat losses to the walls has largest effect. Combustion phasing, CA50, in the fixed compression ratio HCCI cases are at 0°ATDC or earlier at loads below 2bar BMEP, with the Scania D12 cases earliest, see Figure 5. The reason for the Scania D12 at

2000rpm to have higher combustion efficiency than the 1000rpm case is lower air-fuel ratio in the 2000rpm case.

The other source of unburned HC is the crevices. The amount of HC from the crevices is dependent of the volume of the crevice, and the pressure and temperature of the gas in the crevice. The temperature can be assumed to be the same for all three engines, i.e. close to the wall temperature. The maximum cylinder pressure is 8bar higher in the Scania D12 engine at 1000rpm, and 24bar higher at 2000rpm, than in the L850 HCCI and VCR HCCI engine at 2bar BMEP. The estimated crevice volume percentage of the compression volume is about twice as high for the VCR and the L850 engine compared to the Scania D12 engine, about 1.6% compared to 0.9%. Hence the amount of HC from the crevices is also larger for the VCR and the L850 engine compared to the Scania D12 engine decreasing the combustion efficiency of the former engines. In an emissions perspective these high amounts of unburned HC and CO is not a problem since an oxidizing catalyst will take care of them. In a fuel consumption perspective it is not good. The high area-to-volume ratio in the VCR and L850 engines is a result of the chosen bore-to-stroke ratio, the pent-roof combustion chamber, and the high compression ratio.

THERMODYNAMIC EFFICIENCY AND COMBUSTION DURATION

The thermodynamic efficiency, seen in Figure 7, shows the efficiency of the thermodynamic process of heating up the gas at high pressure, expanding the hot gas, and extracting work. All the HCCI engine cases have similar thermodynamic efficiency, e.g. at 2bar BMEP the efficiency is between 46 and 48%, with the Scania D12 at 2000rpm highest. For the L850 SI cases the higher compression ratio case has much higher efficiency, e.g. 40% compared to 30%. The reason is of course the larger expansion ratio. Both combustion phasing, Figure 5, and combustion duration, Figure 8, is about the same for these two SI cases.

The combustion duration, i.e. 10-90% burned, at 2bar BMEP is about 26CAD for the SI cases compared to about 6CAD for the HCCI cases. The difference in thermodynamic efficiency between the SI cases decreases with load, as also earlier mentioned with brake efficiency, due to retarded combustion phasing in the high compression ratio SI to avoid knocking combustion, see Figure 5. With later and later combustion phasing less and less expansion work is extracted from the thermodynamic process. With increasing load combustion duration decreases in the standard L850 SI case improving the thermodynamic efficiency. At 5bar BMEP both SI cases have the same thermodynamic efficiency, compared to 4.5bar BMEP where break even was achieved in brake efficiency. Combustion duration is almost constant for the HCCI cases over the load range, except at low loads below 2bar BMEP where it increases. The lean and low temperature combustion at low load slows down the

chemical kinetics, especially in the boundary layer, and consequently the overall combustion duration increases.

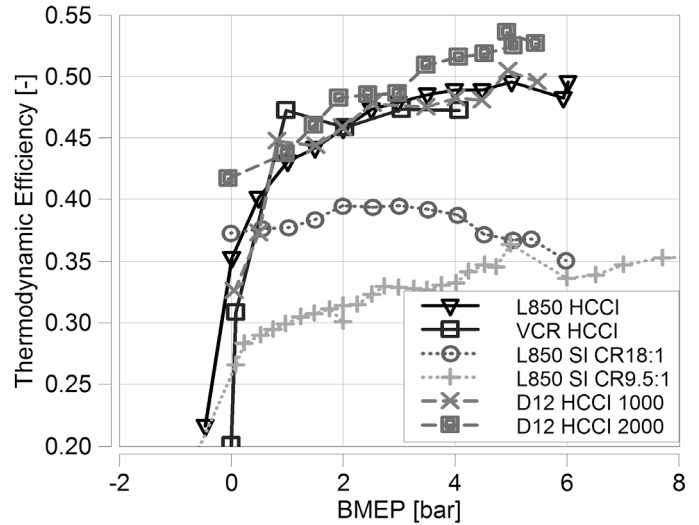

Figure 7: Thermodynamic efficiency as function of BMEP at 2000rpm, except for one of the D12 cases where the engine speed is 1000rpm.

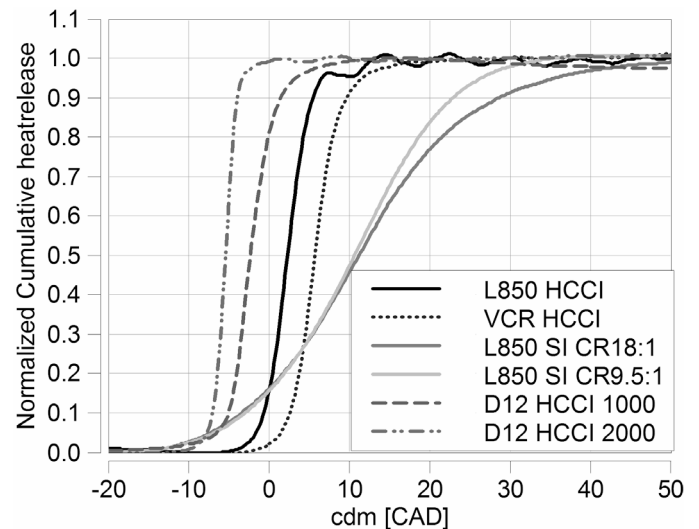

Figure 8: Crank angle resolved normalized cumulative heat release at 2bar BMEP and 2000rpm, except for one of the D12 cases where the engine speed is 1000rpm, mean value of 300 cycles.

HEAT LOSSES TO THE WALLS AND EXHAUST

Despite the fact that the thermodynamic efficiency is about the same for the HCCI cases above 2bar BMEP, except for the Scania D12 at 2000rpm, the heat losses to the walls is not the same. In Figure 9, the cylinder pressure traces from the HCCI engines running at 2bar BMEP are shown, and in Figure 10, the corresponding motored cylinder pressure traces are shown. After inlet valve closing the pressures are at the same level in all of the engines, but they differ at the end of compression before combustion starts. In the motored measurements the maximum pressure also differs. The geometric compression ratios in the engines, at 2bar BMEP for the

VCR engine, are listed in Table 4. The VCR engine has 22:1, L850 HCCI 18:1, and the Scania D12 18.1:1. An effective compression ratio can be calculated, based on the cylinder pressures at maximum and at BDC of the motored pressure traces, isentropic compression, and the ratio of specific heats for air, i.e. 1.4. The effective compression ratios for the VCR engine 14.3:1, for the L850 HCCI 13.3:1, for the Scania at 1000rpm 14.8:1, and at 2000rpm 15.3 respectively, see Table 4. The difference between the geometric and the effective compression ratio can be assumed to relate to the difference in heat losses, if leakage, i.e. blow-by, is neglected and the crevice volumes are taken into account in the geometric calculations. Note also the effect from engine speed in the Scania D12 tests. Compression pressure is higher for the 2000rpm case. The heat loss to the walls decreases with increasing engine speed, due to less time for heat transfer, i.e. the effective compression ratio is higher for the Scania D12 case at 2000rpm. The heat losses without combustion are largest for the VCR engine and smallest for the Scania D12 engine 2000rpm.

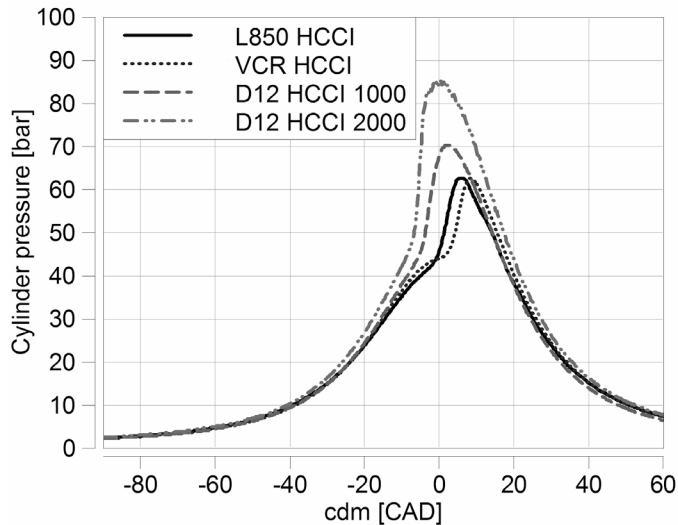

Figure 9: Crank angle resolved cylinder pressures at 2bar BMEP and 2000rpm, except for one of the D12 cases where the engine speed is 1000rpm, mean value of 300 cycles.

Another way to present the heat loss is to calculate them with the help of a heat release model including heat transfer. In Figure 11, the ratio between heat transfer, i.e. $Q_{ht}MEP$, and the total amount of heat released, i.e. $Q_{hr}MEP$, is plotted. The heat transfer is modeled with the Woschni correlation and calibrated with motored pressure traces. The data is from the same operating point at 2bar BMEP as the cylinder pressures presented in Figure 9. The heat transfer ratio in the VCR engine is the highest and this is the reason for the combustion phasing to be the latest of the cases, see CA50 in Figure 5 at 2bar BMEP. The heat transfer ratio is the lowest for the Scania D12 at 2000rpm and since the combustion efficiency improves with earlier combustion phasing, the trade-off between expansion work, combustion efficiency, and heat loss move MBT to earlier

combustion phasing. The effect of engine speed in the Scania case is also seen in Figure 11, i.e. heat transfer decreases with engine speed. The heat transfer ratio in the L850 case is of the same magnitude as in the Scania D12 at 1000rpm during combustion, and consequently higher than in the Scania D12 at 2000rpm, and the combustion phasing later than in the Scania cases. During compression the heat transfer ratio in the L850 case is lower than the Scania D12 at 1000rpm and at the same level as the Scania D12 at 2000rpm, while the cylinder pressure traces in Figure 9 and Figure 10 indicate the opposite. The reason for this is unclear, but inaccuracy in the heat transfer ratio calculation could be a reason.

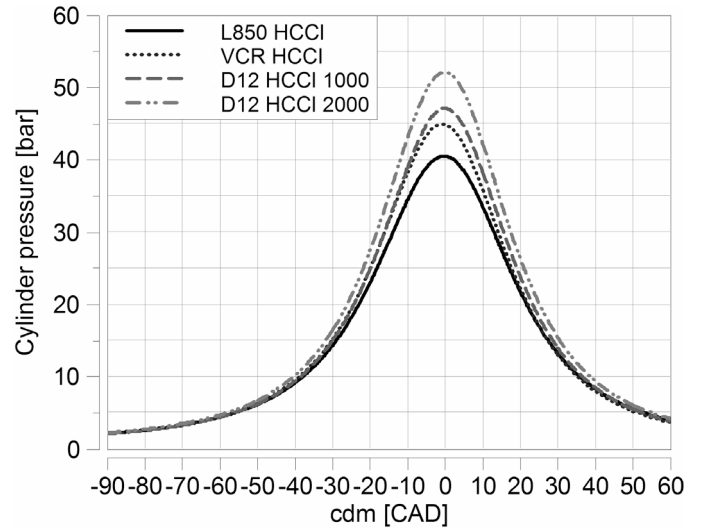

Figure 10: Crank angle resolved motored cylinder pressures at 2000rpm, except for one of the D12 cases where the engine speed is 1000rpm, mean value of 300 cycles

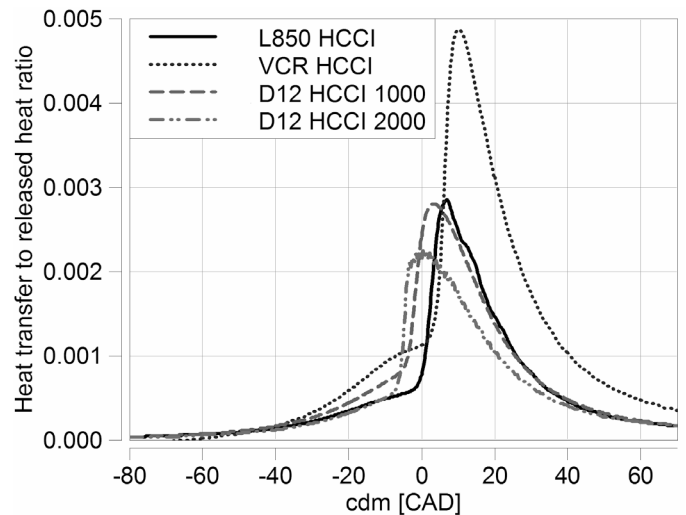

Figure 11: Crank angle resolved heat transfer to walls normalized by the total heat released in the different HCCI cases at 2bar BMEP and 2000rpm, except for one of the D12 cases where the engine speed is 1000rpm, mean value of 300 cycles.

Note also the difference in geometric and effective compression ratio for the VCR engine at maximum compression ratio in Table 4. The geometric is 30:1 and the effective is only 17:3. In a trade-off between inlet air temperature and compression ratio, maximum brake efficiency is found at 22-23:1 in geometric compression ratio. Above 23:1 the heat losses increases, and combustion efficiency decreases, more than the gain in expansion work.

The difference in heat loss between the engines can be understood when looking at the combustion chamber geometry of the different engines. In Figure 12, Figure 13, and Figure 14, the combustion chamber geometries of the VCR, the L850, and the Scania D12 engine are shown respectively. To achieve high compression ratios in the smaller engines the combustion chamber has become very narrow with much wall area. In Table 4, the area-to-volume ratio is calculated for the different engines. The VCR and L850 engines have about 0.6 [1/mm] compared to 0.29 [1/mm] for the Scania D12 engine. Hence, the wall area available for heat transfer is more than double to the volume for the SI based engines, with pent roof combustion chamber, compared to the truck engine, with bowl in piston combustion chamber. The other drawback, already described earlier, is the amount of boundary layer volume.

However, HCCI research has lately shown that in-cylinder temperature stratification can decrease the heat release rate and increase the combustion duration [18, 19, and 20], which would be a benefit for reaching higher load. High load HCCI is restricted by audible noise, caused by too high maximum rate of pressure rise, and NOx emissions. With a temperature distribution in the cylinder a distributed auto ignition slowing down the overall reaction rate can be achieved. With a large area-to-volume ratio one could expect to get a large temperature distribution in the cylinder. However, when comparing combustion duration at high load operation between the HCCI engines at 4bar BMEP, the combustion duration is about the same for all HCCI cases. The air-fuel ratio differences between the engines is in the opposite order to the brake efficiency, i.e. λ is 3.1 in the Scania D12 at 1000rpm, 2.6 in the L850, 2.5 in the Scania D12 at 2000rpm, and 2.3 in the VCR engine at 4bar BMEP. Maximum rate of pressure rise is 60bar/ms, 72bar/ms, 218bar/ms, and 103bar/ms respectively. Compared at the same engine speed both smaller HCCI engines have a slower maximum rate of pressure rise. The air-fuel ratio has some effect on the chemical kinetics and consequently rate of heat release. If the comparison is carried out at the same air-fuel ratio, but at different engine loads, the maximum rate of pressure rise is 60bar/ms for the Scania D12 at 1000rpm, 53bar/ms for the L850, 166bar/ms for the Scania D12 at 2000rpm, and 64bar/ms for the VCR engine. BMEP is 4, 2.7, 2.5, and 2bar respectively. Hence, the maximum rate of pressure rise is slower for the high area-to-volume combustion chambers compared at the same engine speed despite that combustion duration is about the same. Heat release

rate is higher though in the larger engine. Most probably the temperature distribution within the combustion chamber is larger in the smaller HCCI engines due to larger boundary layer percentage than in the truck engine.

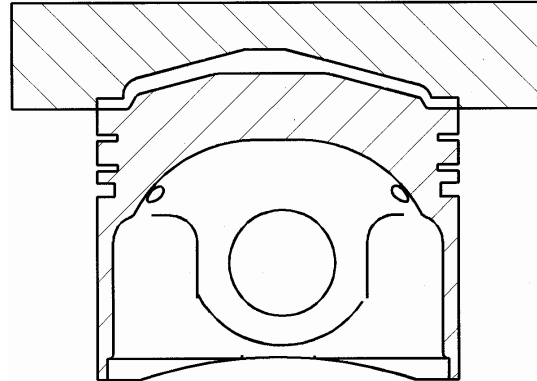

Figure 12: VCR HCCI engine combustion chamber

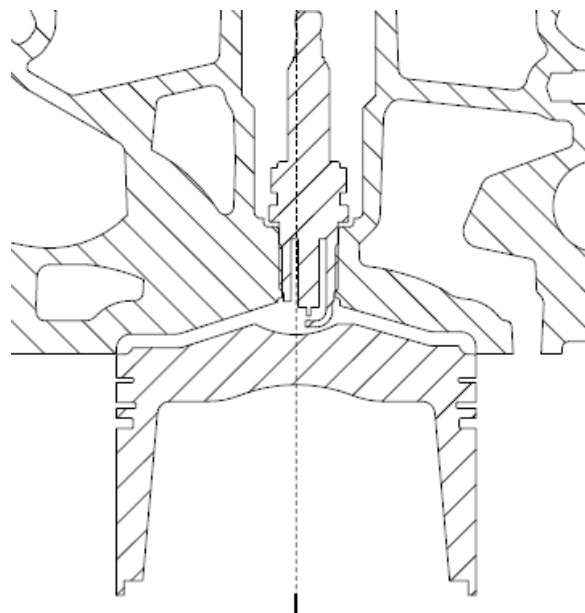

Figure 13: L850 HCCI engine combustion chamber

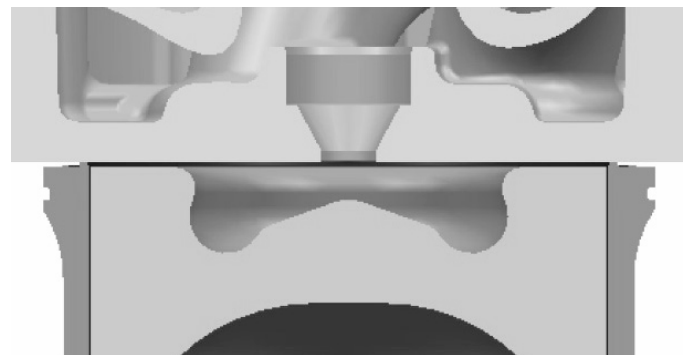

Figure 14: Scania D12 engine combustion chamber

The other energy loss from the combustion chamber that is not utilized for expansion work is the sensible enthalpy

loss in the exhaust gases, i.e. elevated pressure and temperature when the exhaust valve opens. In Figure 15, exhaust gas temperatures after the cylinder is shown. The high compression ratio engines with lean HCCI combustion have much lower exhaust gas temperature and the Scania D12 at 1000rpm has the lowest. The reason is the early combustion phasing and lower engine speed in the Scania D12 at 1000rpm. Lower engine speed gives more time for heat transfer to take place both in the cylinder and in the exhaust port. The measurement technique does also affect the measured temperature. Here the temperature is measured with unshielded thermocouples as a time average value, whereas an accurate measurement should be done with shielded gauges and, if possible, mass average. Nevertheless the measured exhaust temperature gives a hint of the heat losses to the exhaust. The energy loss to the exhaust is smaller for the Scania D12 engine at 1000rpm than for the other HCCI cases.

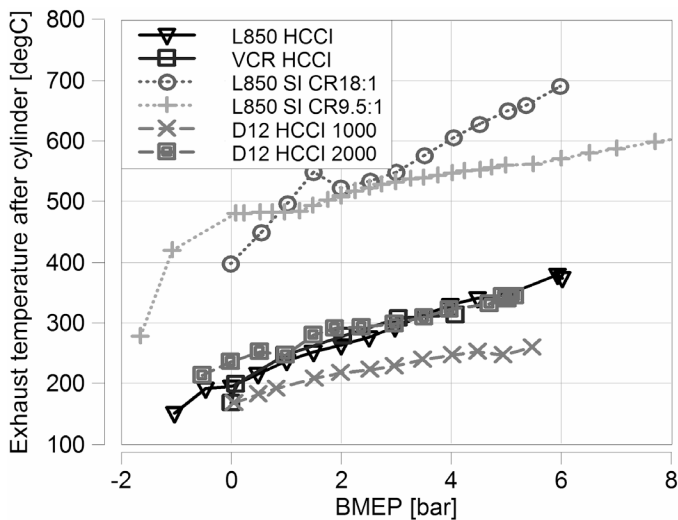

Figure 15: Exhaust gas temperature as function of BMEP at 2000rpm, except for one of the D12 cases where the engine speed is 1000rpm.

Thermodynamic efficiency is slightly higher, 1-3%-units, for the Scania D12 engine at 2000rpm compared to the other HCCI cases, which are at about the same level. Combustion phasing in the Scania D12 at 2000rpm is the earliest of the tested cases since the heat transfer to the walls is the smallest, expansion work is close to maximum, and early combustion phasing increases combustion efficiency. With an even earlier phasing at loads below about 3bar BMEP expansion work would start to decrease since maximum cylinder pressure is close to TDC.

The rest of the HCCI cases, i.e. Scania at 2000rpm excluded, have about the same thermodynamic efficiency though, indicating that the earlier combustion phasing and lower engine speed in the Scania D12 at 1000rpm increases the heat losses to the walls and decreases the expansion work. This results in the same thermodynamic efficiency as in the VCR and L850 engines, despite the smaller area-to-volume ratio. Heat

transfer during combustion, and geometric compression ratio, is comparable between the Scania D12 at 1000rpm and the L850 engine, also seen from the heat transfer ratio in Figure 11. Heat transfer during combustion is the highest for the VCR engine but at the same time the geometric compression ratio is the highest compensating for the high heat losses.

The turbulence levels in the Scania D12 combustion chamber can also be discussed. Is the turbulence level in the Scania D12 higher than in the VCR or L850 HCCI combustion chambers, with all the squish sections removed in the latter engines to maximize the compression ratio, or is the turbulence level scaling more with engine speed, i.e. mean piston speed. However, the difference in mean piston speed is not large due to the longer stroke in the Scania D12 engine, i.e. 5.1m/s at 1000rpm for the Scania D12 and 5.7m/s at 2000rpm for the L850 engine. The turbulence level could be expected to be higher in the Scania D12 engine. A higher turbulence level in the combustion chamber increases the heat losses.

INLET AIR TEMPERATURE REQUIREMENT

Combustion phasing in these HCCI engines is controlled by the inlet air temperature. To set of the chemical reactions in a specific air-fuel mixture, during the time available, a combination of temperature, pressure, and time are required. The in-cylinder temperature is dependent of the amount and temperature of the trapped fresh air-fuel mixture, the amount and temperature of the trapped exhaust residuals, compression ratio, and heat losses to the walls. The wall temperature increases with engine load and consequently the heat transfer to the walls during compression stroke decreases with increasing engine load, i.e. reduces the inlet air temperature requirement. The cooling water temperature after the engine is controlled by a thermostat to about 83°C in the Scania D12 engine and to about 102°C in the L850 and VCR engine, i.e. a higher wall temperature can be expected in the smaller engines decreasing heat transfer during compression stroke. The same conclusion can be made of the oil temperatures used for piston cooling, i.e. the oil temperature is about 110°C in the L850 case, 100°C in the VCR engine, 87°C in the Scania D12 at 1000rpm case, and 97°C in the Scania D12 at 2000rpm case.

The amount and temperature of trapped residuals increases also with load decreasing the inlet air temperature requirement. In these HCCI engines the amount of trapped residuals is affected by inlet air pressure and the exhaust back pressure, which changes with load for the two turbocharged cases, i.e. the L850 and Scania D12 engine. The change in back pressure is larger with the VNT turbocharger in the L850 HCCI engine since the VNT position is adjusted with load. At low load where no charging is needed the back pressure is minimized by opening the VNT, i.e. the pumping losses are minimized. At high load the VNT position and inlet air pressure is optimized for maximum engine load.

However, the Scania D12 has fixed turbine geometry and the exhaust back pressure increases slightly from low to high load with increasing volume flow, i.e. exhaust temperature. Consequently the L850 HCCI case has lower back pressure at low load and higher back pressure at high load than the Scania D12 affecting the inlet air temperature requirement.

The in-cylinder pressure is dependent of the effective compression ratio, inlet air pressure, and heat transfer to the walls, if blow-by is neglected. Inlet air pressure increases with engine load in the turbocharged engines. The effect of boost pressure on combustion phasing has been investigated earlier with the same L850 HCCI engine used in this paper [15]. If inlet air pressure is changed 0.1bar, inlet air temperature has to be changed about 5°C to keep CA50 constant, and 5°C corresponds to a change of about 2CAD in CA50 [15], i.e. 1K \leftrightarrow 0.4CAD.

In Figure 16, the inlet air temperature requirement for auto ignition to achieve a desired CA50 is shown. The inlet air is heated with exhaust in a heat exchanger for the VCR and L850 HCCI engines, while it is electrically heated in the Scania D12 case. This explains the difference in inlet air temperature at low load, around 0bar BMEP, since higher inlet air temperature can be reached with the electrical heater in the Scania, while the inlet air temperature is dependent of the exhaust heat available in the other two engines. If an exhaust-to-inlet air heat exchanger would have been used in the Scania D12 instead of the electrical heater the same inlet air temperatures should be possible to reach, despite lower exhaust temperatures in the 1000rpm case. Heat losses from the exhaust and inlet air piping in a larger engine can be assumed lower compared to the smaller engines used here.

At low load the back pressure and amount of trapped residuals have little effect on the required inlet air temperature, since the exhaust temperature is at the same or lower level as the inlet air temperature. A higher inlet air temperature than exhaust temperature is possible in the exhaust-to-inlet heat exchanger case due to the heat from the oxidizing catalyst. Inlet air pressure is also close to ambient level in the turbocharged cases. The Scania D12 at 1000rpm has the highest inlet air temperature below 1bar BMEP followed by the L850, Scania D12 at 2000rpm, and the VCR engine. The difference between the VCR and the L850 engine is due to different exhaust and inlet air system layout. The L850 engine has shorter piping with less heat losses than the VCR engine. Both engines are dependent on the heat generated by the oxidizing catalysts, and thereby dependent on their oxidizing temperatures, i.e. light off temperatures, at low loads. This is why a maximum temperature is found at about 0bar BMEP, seen on the L850 HCCI inlet air temperature curve. Below 0bar BMEP, exhaust temperature and the heat generated in the catalyst is not high enough to maintain the oxidation.

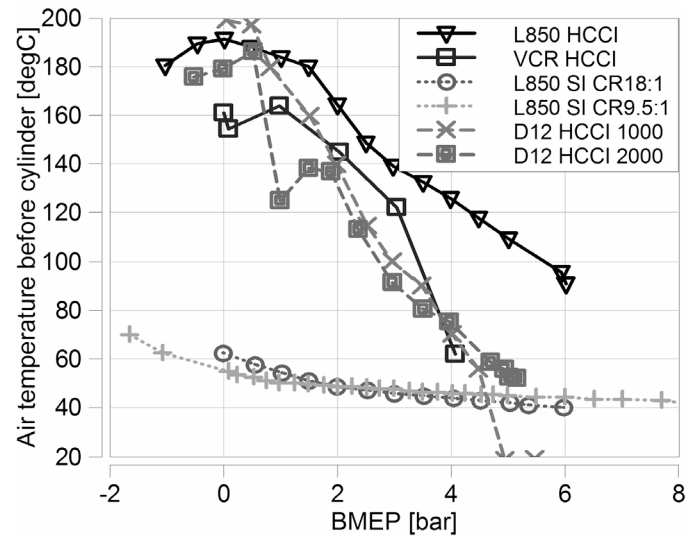

Figure 16: Inlet air temperature as function of BMEP at 2000rpm, except for one of the D12 cases where the engine speed is 1000rpm.

If low temperature reactions would be present they would affect the inlet air temperature requirement. With the VCR engine low temperature reactions (LTR) can be seen with RON91 gasoline at engine speeds up to about 1300rpm and at compression ratios above about 20:1 [23]. At 2000rpm no LTR is present. In the Scania D12, with 18:1 compression ratio, at 1000rpm, no LTR reactions can be seen.

As load increases, the demand for inlet air heating decreases due to; lower air-to-fuel ratio, higher combustion chamber wall temperatures, higher inlet air pressure in the turbocharged cases, and to some extent due to higher back pressure which increases the amount of trapped residuals. If the two turbocharged cases are compared; the L850 case have an increase in back pressure from 0.07bar to 0.8bar, from minimum to maximum load, compared to the Scania D12 at 1000rpm back pressure from 0.16bar to 0.3bar in the same range. The change in inlet air pressure from minimum to maximum load in the L850 HCCI case is about 0.5bar, and in the Scania D12 at both engine speeds about 0.12bar. Hence, exhaust back pressure increases more than the inlet air pressure in these cases and most in the L850 case. So the amount of residuals increases more in the L850 case from low to high load than in the Scania D12 case. The effect on combustion phasing due to the change in inlet air pressure should also be larger for the L850 case than for the Scania cases. However, inlet air temperature requirement decreases more for the Scania D12 cases from minimum to maximum load, with a smaller change in the amount of trapped residuals and inlet air pressure, than in the L850 case, with a larger change in the amount of trapped residuals. Both Scania D12 cases also have earlier combustion phasing than the L850 HCCI case in the entire load range, e.g. at 2bar BMEP shown in Figure 5, the difference is about 4CAD. Hence, the air-fuel mixture is much easier to ignite in the large combustion chamber Scania D12 than in the high area-to-volume ratio L850 HCCI engine and the

difference increases with load. Perhaps due to less amount of charge in the boundary layers in the larger Scania engine.

In the Scania D12 at 1000rpm the engine speed affects the need for inlet air temperature, since there is more time for the chemical reactions to start. At 2bar BMEP the L850 HCCI engine needs 33°C higher inlet air temperature than the Scania D12 engine at 2000rpm. Close to full HCCI load at about 5bar BMEP, the difference is already 56°C compared at the same engine speed. Air-fuel ratio λ is about 2.4 in both cases at this load, while it is 2.9 for the Scania D12 at 1000rpm. The difference in the amount of dilution affects the maximum load potential.

The inlet air temperature for the L850 and VCR cases are measured just before the inlet port, while it is measured in the beginning of the inlet manifold in the Scania D12 case. So the difference between the L850 and the Scania D12 is even larger than measured. One further indication of the difference in the required inlet air temperature is that the Scania D12 can be cold started with HCCI combustion, but the L850 HCCI can not. The inlet air temperature measurements in the smaller engines are not affected by the close position to the engine block, i.e. wall temperatures in the surroundings of the thermocouple, since comparable values are achieved with a common thermocouple placed directly at the inlet to the inlet air manifold.

The VCR HCCI engine inlet air temperature can not be directly compared with the other two HCCI cases, since the compression ratio is changed at the same time. The compression ratio is high at low and high load, and low in the intermediate loads.

GAS EXCHANGE EFFICIENCY

The gas exchange efficiency, in Figure 17, shows the pumping work of the engine. The VCR HCCI engine has the highest gas exchange efficiency, followed by the Scania D12 at 1000rpm and the L850 with comparable efficiency, and lowest is the Scania D12 at 2000rpm. Hence, gas exchange efficiency does not affect the difference in brake efficiency between the L850 and the Scania D12 at 1000rpm, while the efficiency is poor with the Scania D12 at 2000rpm.

The main reason for the VCR engine to have higher gas exchange efficiency than the other HCCI engines is the absence of a turbocharger, i.e. the exhaust back pressure is lower. The other reason is some gas dynamics, ramming, in the inlet. The inlet air runners are longer for the VCR case compared to the others resulting in a small ramming effect at 2000rpm. The Scania D12 is obviously not optimized to run at 2000rpm at all. The low gas exchange efficiency at 2000rpm is one of the main reasons for the lower brake efficiency compared to the 1000rpm case.

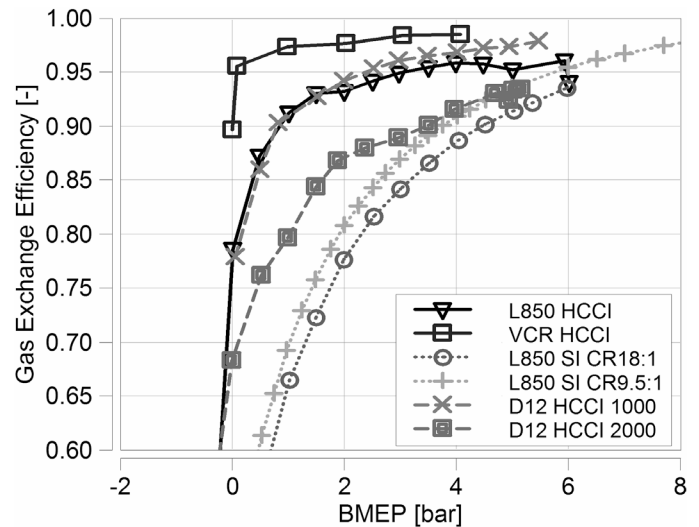

Figure 17: Gas exchange efficiency as function of BMEP at 2000rpm, except for one of the D12 cases where the engine speed is 1000rpm.

Both SI engines have much higher pumping work due to the load control by throttling. The high compression ratio SI has the lowest gas exchange efficiency due to its higher brake efficiency. However, the gas exchange efficiency increases rapidly with load in the SI engines and a break even between the HCCI and the SI engines could be estimated to be around 8bar BMEP.

INDICATED EFFICIENCY

The net indicated efficiency for the six cases is shown in Figure 18. All the HCCI cases, independent of engine, have similar net indicated efficiency, e.g. at 2bar BMEP about 40%. The VCR and Scania D12 HCCI as actually slightly higher indicated efficiencies than the L850 HCCI, and the VCR HCCI has the highest between 0 and 2bar BMEP. The small difference between the L850 and the Scania D12 at 1000rpm, e.g. about 2% units at 2bar BMEP, is due to the difference in combustion efficiency, since both have about the same thermodynamic and gas exchange efficiency. The reason why both of the Scania D12 cases have comparable net indicated efficiencies is that the 1000rpm case has higher gas exchange efficiency, while the 2000rpm case has higher combustion efficiency.

The VCR engine has slightly higher indicated efficiency than the L850 HCCI due to the higher gas exchange efficiency. The VCR and the L850 HCCI engines have about the same combustion and thermodynamic efficiencies. In between the indicated efficiency and the brake efficiency both the L850 and the VCR engine still waste energy and the last explanation is the friction losses. Of the two L850 SI cases the high compression ratio SI has highest indicated efficiency as expected due to the higher thermodynamic efficiency.

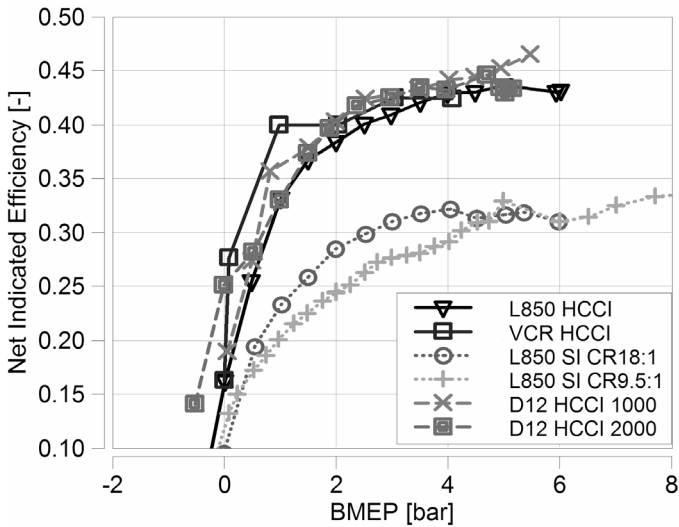

Figure 18: Indicated efficiency as function of BMEP at 2000rpm, except for one of the D12 cases where the engine speed is 1000rpm.

MECHANICAL EFFICIENCY

The last parameter to affect the brake efficiency is the mechanical efficiency, i.e. the friction losses of the engine. The mechanical efficiency of the test engines can be seen in Figure 19. The Scania D12 at 1000rpm and the L850 standard SI engine have the highest mechanical efficiencies, followed by the L850 high compression ratio SI, the L850 HCCI, Scania D12 at 2000rpm, and at lowest the VCR HCCI engine. This is the reason why the VCR HCCI engine has the lowest brake efficiency of the HCCI engines and why the Scania D12 at 2000rpm has the second lowest.

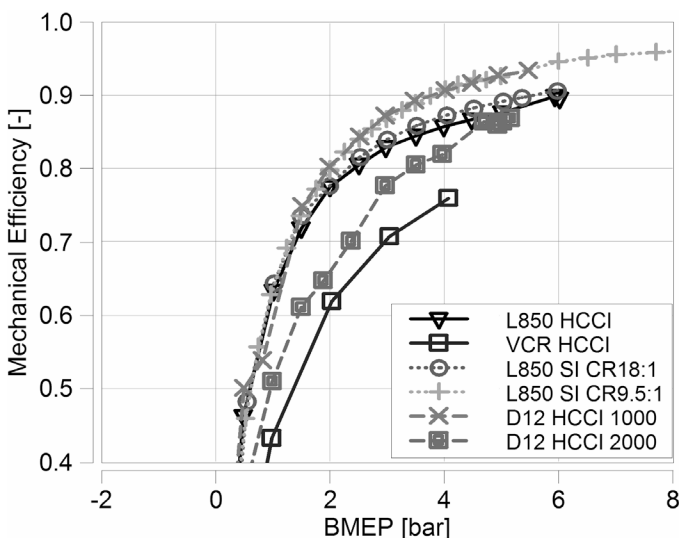

Figure 19: Mechanical efficiency as function of BMEP at 2000rpm, except for one of the D12 cases where the engine speed is 1000rpm.

The VCR engine features a fairly robust construction with many small cylinders. Here is also the second explanation why the brake efficiency of the L850 HCCI engine is lower than for the Scania D12 HCCI engine at

1000rpm. The Scania D12 at 1000rpm and the L850 standard SI have the same mechanical efficiency, but decreased for the L850 engine when the compression ratio was increased to 18:1. The higher cylinder pressure with higher compression ratio increases the friction from the piston rings and bearings. The same conclusion, as when comparing gas exchange efficiency, can be done for the Scania D12 at 2000rpm, i.e. it is not optimized for these high engine speeds.

DISCUSSION

Three different HCCI engines with different cylinder displacements were compared in this paper. The combustion chamber design is completely different in two of the engines causing a large difference in area-to-volume ratio compared to the third. The engines have about the same indicated efficiency, thermodynamic efficiency, and gas exchange efficiency, but different brake efficiency, if the Scania D12 at 2000rpm is excluded. The truck size engine at 1000rpm has the highest brake efficiency and the reason is higher combustion and mechanical efficiency than the smaller engines. However this tells us that there is room for improvement in the smaller engines. The high area-to-volume ratio decreases the combustion efficiency in the two smaller engines. The reason for the high area-to-volume ratio is the cast pent-roof combustion chamber in combination with high compression ratio. With a flat and machined cylinder head the tolerances can be kept small with high compression ratios, and a bowl-in-piston combustion chamber can be made to decrease the area-to-volume ratio in the combustion chamber in engines with small displacements. Hence, a diesel engine type of combustion chamber, but with simpler and wider bowl geometry. The squish areas will increase the boundary layer volume but enough space should be achieved in the bowl to maximize the bulk volume. If a long enough stroke is available, e.g. low bore-to-stroke ratio and large displacement, a pancake combustion chamber would be optimal. A pancake combustion chamber will decrease the turbulence level and the cooling losses to the walls. If a larger temperature distribution in the cylinder is desired to decrease the combustion rate [18, 19, and 20] a pancake combustion chamber is not optimal.

The differences in mechanical efficiency between the engines are more difficult to solve. The friction losses will always be larger with smaller cylinder displacement and higher compression ratio. The individual cylinder displacement should be kept as large as possible with regard to other demands on engine design.

CONCLUSIONS

The performance of three multi-cylinder HCCI engines with different displacements has been compared. The engines are a five-cylinder 1.6dm³ VCR engine, a four-cylinder 2.0dm³ engine, and a six-cylinder 11.7dm³ truck engine. The comparisons are performed at 2000rpm and also at 1000rpm for the truck engine. HCCI combustion is achieved with high compression ratio, air as dilution,

and inlet air heating. Regular gasoline, RON91, is used as fuel.

- The truck HCCI engine at 1000rpm has the highest brake efficiency, the 2.0dm³ HCCI engine the second highest, the truck HCCI engine at 2000rpm the third highest, and the VCR engine the lowest. The brake efficiencies are, at 2bar BMEP, 32.3%, 29.8%, 26.4%, and 24.4% respectively.
- The truck engine has higher combustion efficiency, at both engine speeds, than the smaller engines, 93-96% compared to about 90% at 2bar BMEP. The reasons are smaller crevice volume percentage of compression volume, smaller area-to-volume ratio, i.e. less boundary volume percentage, and earlier combustion phasing compared to the 2.0dm³ HCCI and the VCR engine.
- The compared engines have about the same thermodynamic efficiency of 46% at 2bar BMEP. The heat losses during compression are higher for the smaller engines, due to the large area-to-volume ratio, but the heat losses are higher for the truck engine during combustion, due to the early combustion phasing. With a later combustion phasing in the truck engine the thermodynamic efficiency could have been higher but to the cost of lower combustion efficiency.
- The VCR engine has the highest gas exchange efficiency of 97.7% at 2bar BMEP, while the truck at 1000rpm and the 2.0dm³ HCCI engines have about the same gas exchange efficiency of 93-94%. One reason for the lower efficiency is that the VCR engine has no turbocharger, while the two other has. The truck engine at 2000rpm has lowest the gas exchange efficiency, i.e. 87%.
- The truck engine at 1000rpm has the highest mechanical efficiency, i.e. 80%, the 2.0dm³ HCCI has 78%, the truck engine at 2000rpm 66%, and the VCR engine 61% mechanical efficiency at 2bar BMEP. Friction losses scale with cylinder displacement, if the truck engine 2000rpm case is excluded. The truck size engine is optimized for lower engine speeds than 2000rpm.
- The reasons for the higher brake efficiency of the truck engine at 1000rpm compared to the smaller engines are higher combustion and mechanical efficiency. At the low loads where HCCI of today is mainly intended, these two have a large impact on the fuel consumption.

ACKNOWLEDGMENTS

This project is supported by GM Powertrain Sweden and the Swedish Energy Agency through the Green Car project.

REFERENCES

1. Erlandsson O., Early Swedish Hot-Bulb Engines – Efficiency and Performance Compared to Contemporary Gasoline and Diesel Engines, SAE 2002-01-0115
2. Onishi S., Jo S.H., Shoda K., Jo P.D., Kato S., Active Thermo-Atmosphere Combustion (ATAC) – A New Combustion Process for Internal Combustion Engines, SAE 790501
3. Noguchi M., Tanaka Y., Tanaka T., Takeuchi Y., A Study on Gasoline Engine Combustion by Observation of Intermediate Reactive Products during Combustion, SAE 790840
4. Najt P., Foster D.E., Compression-Ignited Homogeneous Charge Combustion, SAE 830264
5. Thring R.H., Homogeneous-Charge Compression-Ignition (HCCI) Engines, SAE 892068
6. Drangel H., Bergsten L., The new Saab SVC Engine - An Interaction of Variable Compression Ratio High Pressure Supercharging and Downsizing for Considerably Reduced Fuel Consumption, 9. Aachener Kolloquium Fahrzeug- und Motorentechnik 2000.
7. Haraldsson G., Hyvönen J, Tunestål P., Johansson B., HCCI Combustion Phasing in a Multi Cylinder engine using Variable Compression Ratio, SAE 2002-01-2858
8. Haraldsson G., Hyvönen J., Tunestål P., Johansson B., HCCI Combustion Phasing with Closed-Loop Combustion Control Using Variable Compression Ratio in a Multi Cylinder Engine, JSAE 20030126 / SAE 2003-01-1830
9. Hyvönen J., Haraldsson G., Johansson B., Operating range in a Multi Cylinder HCCI engine using Variable Compression Ratio, JSAE 20030178 / SAE 2003-01-1829
10. Hyvönen J., Haraldsson G., Johansson B., Supercharging HCCI to extend the operating range in a Multi-Cylinder VCR-HCCI engine, SAE 2003-01-3214
11. Haraldsson G., Hyvönen J., Tunestål P., Johansson B., HCCI Closed-Loop Combustion Control Using Fast Thermal Management, SAE 2004-01-0943
12. Hyvönen J., Haraldsson G., Johansson B., Balancing cylinder-to-cylinder variations in a Multi-Cylinder VCR-HCCI engine, SAE 2004-01-1897
13. Hyvönen J., Haraldsson G., Johansson B., Operating conditions using spark assisted HCCI combustion during combustion mode transfer to SI in a Multi-Cylinder VCR-HCCI engine, SAE 2005-01-0109
14. Haraldsson G., Hyvönen J., Tunestål P., Johansson B., Transient Control of a Multi Cylinder HCCI Engine during a Drive Cycle, SAE 2005-01-0153
15. Hyvönen J., Johansson B., HCCI Operating range with VNT Turbo charging, Congress „Haus der Technik“ Controlled Auto Ignition, 20.-21.Oktober 2005, Essen

16. Olsson J.O., Tunestål P., Haraldsson G., Johansson B., A Turbo Charged Dual Fuel HCCI Engine, SAE 2001-01-1896
17. Aceves, S.M., Flowers, D.L., Espinosa-Loza, F., Martinez-Frias, J., Dibble, R.W., Christensen, M., Johansson, B., and Hessel, R.P., Piston-Liner Crevice Geometry Effect on HCCI Combustion by Multi-Zone Analysis, SAE 2002-01-2869
18. Yoshizawa K., Teraji A., Miyakubo H., Yamaguchi K., Urushihara T., Study of high load operation limit expansion for gasoline compression ignition engines, ICES2003-543
19. Sjöberg, M., Dec, J.E., Cernansky, N.P., Potential of Thermal Stratification and Combustion Retard for Reducing Pressure Rise Rates in HCCI Engines, based on Multi-zone Modeling and Experiments, SAE 2005-01-0113
20. Aceves S.M., Flowers D.L., Martinez-Frias J., Espinosa-Loza F., Christensen M., Johansson B., Hessel R.P., Analysis of the Effect of Geometry Generated Turbulence on HCCI Combustion by Multi-Zone Modeling, SAE 2005-01-2134
21. Muranaka S., Takagi Y., Ishida T., Factors limiting the improvement in thermal efficiency of S.I. engine at higher compression ratio, SAE-870548
22. Hiltner J.D., Fiveland S., Agama R., Willi M., System Efficiency Issues for Natural Gas Fueled HCCI Engines in Heavy-Duty Stationary Applications, SAE 2002-01-0417
23. Hyvönen J., The Performance of a Multi Cylinder HCCI Engine using Variable Compression Ratio and Fast Thermal Management, Doctoral Thesis at Lund University, 2005

CLD: Chemiluminescence's Light Detector
CO: Carbon Monoxide
CO₂: Carbon Dioxide
COV: Coefficient of Variation
DI: Direct Injection
DOHC: Dual Over Head Cam
FID: Flame Ionization Detector
FMEP: Friction Mean Effective Pressure
FuelMEP: Fuel Mean Effective Pressure
HC: Hydro Carbons
HCCI: Homogeneous Charge Compression Ignition
IMEP: Indicated Mean Effective Pressure
MEP: Mean Effective Pressure
MON: Motor Octane Number
NDIR: Non Dispersive Infrared
NO_x: Nitrogen Oxides (NO and NO₂)
LTC: Low Temperature Combustion
LTR: Low Temperature Reactions
PCI: Peripheral Component Interconnect local bus
PFI: Port Fuel Injection
PMEP: Pumping Mean Effective Pressure
QemisMEP: Emission Mean Effective Pressure
QexhMEP: Exhaust heat loss Mean Effective Pressure
QhrMEP: Heat Release Mean Effective Pressure
QhtMEP: Heat Transfer Mean Effective Pressure
RON: Research Octane Number
SI: Spark Ignition
SVC: Saab Variable Compression
UEGO: Universal Exhaust Gas Oxygen sensor
VCR: Variable Compression Ratio

CONTACT

Jari Hyvönen, M.Sc. M.E.
 E-mail: jari.hyvonen@vok.lth.se

Lund Institute of Technology, Department of Energy Sciences, Division of Combustion Engines, P.O.Box 118, SE-221 00 Lund, Sweden.

DEFINITIONS, ACRONYMS, ABBREVIATIONS

ABDC: After Bottom Dead Center
ATAC: Active Thermo-Atmosphere Combustion
ATDC: After Top Dead Center
BMEP: Brake Mean Effective Pressure
BBDC: Before Bottom Dead Center
BTDC: Before Top Dead Center
CAD: Crank Angle Degree
CA50: Crank Angle of 50% burnt
CI: Compression Ignition

APPENDIX

The variables used in this paper are defined in this section. Most of the variables are calculated by the help of Mean Effective Pressures that are a practical way to magnify different variables in an equivalent way as Brake Mean Effective Pressure.

The brake efficiency is defined as:

$$\eta_{brake} = \frac{BMEP}{FuelMEP}$$

where BMEP is Brake Mean Effective Pressure and FuelMEP is Fuel Mean Effective Pressure.

The Brake Mean Effective Pressure is defined as:

$$BMEP = \frac{P * n_R}{V_d * N}$$

where P [W] is engine power output, n_R is number of crank revolutions for each power stroke (one for two-stroke and two for two-stroke engines), V_d [m³] is engine displacement, and N [rev/s] is engine speed.

The Fuel Mean Effective Pressure is defined as:

$$FuelMEP = \frac{m_f * Q_{LHV}}{V_d}$$

where m_f [kg] is the mass of fuel supplied per cycle, Q_{LHV} [J/kg] is the lower heating value for the fuel, and V_d [m³] is the displacement of the engine.

Net Indicated Efficiency is defined as:

$$\eta_{indicated} = \frac{IMEP_{net}}{FuelMEP}$$

where IMEP_{net} is net Indicated Mean Effective Pressure defined as:

$$IMEP_{net} = \frac{\int_{360}^{-360} p dV}{V_d}$$

where the indicated work per cycle is integrated from the pressure-Volume diagram over the entire four-stroke cycle.

The Thermodynamic Efficiency is defined as:

$$\eta_{thermodynamic} = \frac{IMEP_{gross}}{Q_{hrMEP}}$$

where IMEP_{gross} is gross Indicated Mean Effective Pressure defined as:

$$IMEP_{gross} = \frac{\int_{180}^{-180} p dV}{V_d}$$

where the indicated work per cycle is integrated from the pressure-Volume diagram over the compression and expansion stroke only in the four-stroke cycle.

Gas Exchange Efficiency is defined as:

$$\eta_{GasExchange} = \frac{IMEP_{net}}{IMEP_{gross}}$$

Mechanical Efficiency is defined as:

$$\eta_{mechanical} = \frac{BMEP}{IMEP_{net}}$$

Combustion Efficiency is defined as:

$$\eta_{combustion} = \frac{Q_{hrMEP}}{FuelMEP}$$

where the Heat Release Mean Effective Pressure, Q_{hrMEP} , is defined as:

$$Q_{hrMEP} = \frac{Q_{HR}}{V_d}$$

where Q_{HR} [J] is the heat released in the cylinder during an engine cycle and calculated with a heat release model including heat transfer. In this paper, however, the Combustion Efficiency is calculated from the incomplete combustion products in the exhaust, measured by the exhaust gas analyzer, and compared with the supplied fuel heat.

The combustion efficiency is defined as:

$$\eta_{combustion} = \frac{\sum m_i * Q_{LHV,i}}{m_f * Q_{LHV,f}}$$

where m_i [kg] is the mass of CO and HC respectively, $Q_{LHV,i}$ [J/kg] is the lower heating value for CO and HC respectively, m_f [kg] is the mass of the supplied fuel, and $Q_{LHV,f}$ [J/kg] is the lower heating value for the fuel. Q_{hrMEP} is then calculated with:

$$Q_{hrMEP} = \eta_{combustion} * FuelMEP$$

The Brake Efficiency can also be calculated as a product of the other efficiencies:

$$\eta_{brake} = \eta_{combustion} * \eta_{thermodynamic} * \eta_{mechanical} * \eta_{GasExchange}$$

Other useful Mean Effective Pressures can also easily be derived from the presented ones. Pumping Mean Effective Pressure is defined as:

$$PMEP = IMEP_{gross} - IMEP_{net}$$

Friction Mean Effective Pressure is defined as:

$$FMEP = IMEP_{net} - BMEP$$

The Emission Mean Effective Pressure, i.e. the energy lost from the cylinder as unburned in the exhaust, is defined as:

$$Q_{emisMEP} = FuelMEP - Q_{hrMEP}$$

Heat Transfer Mean Effective Pressure, i.e. the heat transferred to the cylinder walls, is defined as:

$$Q_{htMEP} = \frac{Q_{HT}}{V_d}$$

where Q_{HT} [J] is the heat transferred to the cylinder walls during the compression and expansion cycle and can be derived from the heat release model.

The Exhaust heat loss Mean Effective Pressure, i.e. the apparent heat lost in the exhaust gases, is defined as:

$$Q_{exhMEP} = Q_{hrMEP} - IMEP_{gross} - Q_{htMEP}$$

Q_{exhMEP} could also be calculated from the exhaust enthalpy. The list of Mean Effective Pressures can be extended to whatever energy flow of interest.