



LUND UNIVERSITY

Leaching of concrete : the leaching process : extrapolation of deterioration : effect on the structural stability

Fagerlund, Göran

2000

[Link to publication](#)

Citation for published version (APA):

Fagerlund, G. (2000). *Leaching of concrete : the leaching process : extrapolation of deterioration : effect on the structural stability*. (Report TVBM; Vol. 3091). Division of Building Materials, LTH, Lund University.

Total number of authors:

1

General rights

Unless other specific re-use rights are stated the following general rights apply:

Copyright and moral rights for the publications made accessible in the public portal are retained by the authors and/or other copyright owners and it is a condition of accessing publications that users recognise and abide by the legal requirements associated with these rights.

- Users may download and print one copy of any publication from the public portal for the purpose of private study or research.
- You may not further distribute the material or use it for any profit-making activity or commercial gain
- You may freely distribute the URL identifying the publication in the public portal

Read more about Creative commons licenses: <https://creativecommons.org/licenses/>

Take down policy

If you believe that this document breaches copyright please contact us providing details, and we will remove access to the work immediately and investigate your claim.

LUND UNIVERSITY

PO Box 117
221 00 Lund
+46 46-222 00 00

Lund Institute of Technology
Lund University

Division of Building Materials

EC Innovation project IN30902I

CONTECVET
A validated Users Manual for
assessing the residual service life
of concrete structures

LEACHING OF CONCRETE
The leaching process.
Extrapolation of deterioration.
Effect on the structural stability

Göran Fagerlund

Also published as Report TVBM-3091
Div. of Building Materials
Lund Institute of Technology
Lund 2000

Preface

This work is part of a European research project CONTECVET; *A Validated Users Manual for Assessing the Residual Service Life of Concrete Structures*.

The project involves partners from U.K., Spain and Sweden:

U.K.:

British Cement Association (Coordinator)
Transport Research Laboratory
National Car Parks

Spain:

Geocisa
Generalitat Valenciana
Instituto Eduardo Torroja
Enresa S.A.
Iberdrola S.A.

Sweden:

Swedish Cement and Concrete Research Institute
Lund Institute of Technology
Vägverket (Swedish National Road Administration)
Banverket (Swedish National Railway Administration)
Vattenfall Utveckling
Skanska AB

The project is lead by professor George Somerville, British Cement Association.

Three major destruction mechanisms are considered in the project; alkali silica reaction (ASR), freeze-thaw, and reinforcement corrosion. Some partners are also interested in leaching. This report is meant to be a condensed introduction to the subject. Unfortunately, there are rather few mechanistic studies of leaching performed. Therefore, this report is hardly at all supported by real facts on leaching. It only gives a general structure for the manner in which a leaching problem might be solved and used in an analysis of the structural stability.

Lund, May 2000

Göran Fagerlund

(Research on leaching and its effect on the structural stability has also been published in the report:
T. Ekström: Leaching of concrete. Experiments and modelling. Div. of Building Materials, Lund Institute of Technology. Report TVBM-3090, Lund, 2001)

Abstract

The leaching process when water attacks concrete, and the effect of leaching on the strength and durability of a concrete structure, is analysed theoretically. Technique for prediction of the future leaching and structural stability is outlined. The analysis is to a certain extent supported by data from literature.

The leaching process is divided in five different types:

- 1: Pure surface leaching
- 2: Surface leaching involving erosion
- 3: Homogeneous leaching over the entire structure
- 4: Semi-homogeneous leaching over the entire structure
- 5: Leaching in defects within the structure

For each type, the physical leaching process is outlined. Consideration is taken to the increase in permeability caused by leaching making it theoretically possible to predict the future leaching from an analysis of the water flow and degree of leaching at the time of inspection of the structure.

The effect of leaching on strength and E-modulus of the concrete is analysed showing that the effect can be substantial.

A short discussion is made on the effect of leaching on the structural stability and on the changes in structural stability in the future. Important mechanical factors discussed are changes in compressive strength, tensile strength and bond strength between reinforcement and concrete. The increased risk of reinforcement corrosion and frost damage in leached concrete is discussed and found to be big. The effect of changes in the internal uplift pressure in dams due to changed flow paths inside the dam and the effect of these changes on the dam stability are mentioned.

Finally, in an APPENDIX, a simple method is outlined for how to assess the concrete strength from information of the physical composition of the cement paste. By this theory it is also possible to assess the effect of leaching on the concrete strength.

CONTENTS

Preface	1
Abstract	2
Contents	3

I: THE LEACHING PROCESS

I:1 The solubility of concrete	5
I:1.1 Solubility of "lime"	5
I:1.2 Amount of soluble lime in concrete	8
I:2 Types of leaching	9
I:2.1 Introduction	9
I:2.2 Leaching of type 1; Surface leaching with no erosion and no water pressure gradient	9
I:2.3 Leaching of type 2; Surface leaching as in Type 1 but with erosion	12
I:2.4 Leaching of type 3; Homogeneous internal leaching with water pressure gradient	14
I:2.4.1 Requirements for homogeneous leaching	14
I:2.4.2 The amount of dissolved lime	17
I:2.5 Leaching of type 4; Semi-homogeneous internal leaching with water pressure gradient	18
I:2.6 Leaching of type 5; Selective leaching in defects and cracks under water pressure gradient	19
I:3 Relation between water flow and dissolution	22

II: EXTRAPOLATION OF DETERIORATION

II:1 Extrapolation of water flow and dissolution	25
II:1.1 Surface leaching of type 1	25
II:1.2 Surface leaching of type 2	26
II:1.3 Homogeneous leaching of type 3	26
II:1.3.1 No change in permeability due to leaching	25
II:1.3.2 Gradual increase in permeability due to leaching	28
II:1.4 Semi-homogeneous leaching of type 4	32
II:1.5 Selective leaching of type	33
II:2 Extrapolation of strength	35
II:2.1 Effect of leaching on strength	35
II:2.2 Extrapolation of strength	38

II.3 Extrapolation of E-modulus	40
II:3.1 Effect of leaching on E-modulus	40
II:3.2 Extrapolation of E-modulus	41

III: EFFECT OF LEACHING ON THE STRUCTURAL STABILITY

III:1 Introduction	42
III:2 Concrete strength	43
III:2.1 Compressive and tensile strength	43
III:2.2 Bond strength	43
III:3 Reinforcement corrosion	45
III:3.1 Introduction	45
III:3.2 Carbonation	45
III:3.3 Chloride induced corrosion	48
III:3.4 Corrosion in cracks	52
III:4 Frost attack	53
III:4.1 Different types of frost attack	53
III:4.2 Internal frost attack	53
III:4.3 Salt-frost scaling	55
III:5 Uplift and overturning of the structure	56

APPENDIX

Relation between the materials structure and strength	57
--	----

I: The leaching process

I:1 The solubility of concrete

I:1.1 Solubility of "lime"

Water dissolves lime in concrete. The solubility depends on the hardness (acidity) of the water and on the type of lime in the concrete. The more acid the water, the higher its ability to dissolve concrete. Portlandite ($\text{Ca}(\text{OH})_2$) is more soluble than hydrated calcium silicate (CSH), which in turn is more soluble than calcite in carbonated concrete (CaCO_3). Aluminate and ferrite compounds in cement gel seem highly insoluble also in rather acid water¹. The interrelation between water hardness expressed in terms of German hardness degree and amount of aggressive carbon acid was determined already in the thirties². A summary of this investigation is shown in Table I.1.

Table I.1: The aggressiveness of water to concrete.

Water type	Water hardness German degree ¹⁾	Aggressive CO_2 in water [mg/l]	Aggressiveness
I	>2.0	<15	Not aggressive
II	>2.0 2.0-0.2	15-40 <15	Insignificant
III	>2.0 2.0-0.2 <0.2	40-90 14-40 <15	Significant
IV	>2.0 2.0-0.2 <2.0	>90 >40 >15	High

1) 1 German degree = 10 mg dissolved CaO per litre of water

Natural water, by which is meant ground water, or water in lakes and rivers, can have very different chemical composition depending on the type of ground through which it has flown. It might be very hard in areas where the ground is calcareous, or it might be rather acid in areas where the soil consists of peat and other material rich in organic substances. In the northern parts of Scandinavia, and possibly also in other mountainous areas, water can be very pure since it mainly emanates from melting snow.

¹ L. Rombén: Aspects on testing methods for acid attack on concrete - further experiments. Swedish Cement and Concrete Research Institute, Research Fo2:79, 1979.

² H. Granholm, D. Werner, S. Giertz-Hedström: Investigation of the suitability of using concrete for pipes. Betong 1934:1. (In Swedish)

Pure water has high ability to dissolve lime. Industrial water, such as waste water or water from industrial processes, has highly varying chemical composition. It might have pH-values below 4.5 which means that it is very aggressive. But, also very pure water is produced in industrial processes, such as water from condensation of water vapour in heat exchangers, or in cooling towers, etc. Such water is rather aggressive as seen in Table 1.

The solubility of lime *decreases* with increased temperature. Pure water (no dissolved CaO or CO₂, and pH=7) dissolves the following amount of calcium hydroxide (Ca(OH)₂):

0°C:	1.85 g/litre
20°C:	1.65 g/litre
100°C:	0.71 g/litre

I:1.2 Amount of soluble lime in concrete

A concrete made with the *portland cement* content C kg/m³ contains the following amount of CaO in different phases. It is assumed that the degree of hydration is 80%.

1: The total amount of lime expressed as CaO:	0.65·C kg/m ³
2: The amount of CaO bound in hydration products (gel+portlandite):	0.53·C
3: The amount of CaO bound in Ca(OH) ₂ (portlandite):	0.12·C
4: The amount of CaO bound in cement gel:	0.41·C
5: The amount of CaO bound in unreacted cement:	0.13·C

The total weight of cement paste is C(1+0.25·α) where α is the degree of hydration. A normal degree of hydration is 80%. This means that the total weight of cement paste is 1.2·C kg/m³.

The total weight of all soluble calcareous substances in cement paste (all lime based products except those in unhydrated cement) is about 1.25·α·C or 1.0·C when α=0.8. Thus, the *weight fraction* of all soluble substances in cement paste is about 1/1.2≈85%.

The total weight of CSH-gel exclusive of reaction products from C₃A and C₄AF but including Ca(OH)₂ is about 0.79·C (60% C₃S and 20% C₂S in the cement). Thus, the *weight fraction* of such easily soluble reaction products in the cement paste is 0.79/1.2≈65%.

The total weight of more insoluble reaction products from C₃A and C₄AF is about 0.25·C (8% C₃A, 12% C₄AF). Thus, the *weight fraction* of the cement paste of such less soluble reaction products is 0.25/1.2≈20%.

The total weight of Ca(OH)₂ in the cement gel is about 0.30·C. Thus, the *weight fraction* of very soluble Ca(OH)₂ in the cement paste is 0.30/1.2≈25%.

The total *volume* of hydration products (including gel porosity) is $0.71 \cdot \alpha \cdot C$; see the APPENDIX, Fig A.1. The total volume of cement paste is $(w+0.32 \cdot C)$ where w is the amount of mixing water. Thus, the volume fraction of cement gel is $0.71 \cdot \alpha / (w/c + 0.32)$. For a w/c -ratio of 0.60 and a degree of hydration of 80% the *volume fraction* of soluble substances in the cement paste is about 62%.

As a first approximation the density is supposed to be the same for all hydration products. Thus, *dissolution of all CSH-gel reduces the solid volume of the cement paste by 47%. Dissolution of all Ca(OH)₂ reduces the volume by 18%.*

I:2 Types of leaching

I:2.1 Introduction

The characteristics and time process of leaching depend on the permeability of the concrete and on the pressure gradient of water in the concrete structure. It also depends on whether erosion occurs or not. Five different processes can be discerned. See Fig. I.1 and Fig. I.4-I.7.

In leaching of type 1 and 2 all easily dissolvable lime is dissolved in the leached zone. On a bigger depth than this there is no leaching.

In leaching of type 3 and 4 the dissolvable lime is gradually reduced with time within the entire structure. In leaching of type 3 the removal of lime is the same in all parts of the structure. In leaching of type 4 more lime is removed from the upstream part of the structure than from the downstream part.

Leaching of type 5 is localized to certain parts in the concrete, or to crack walls. Lime is gradually removed with time within these localized areas.

I:2.2 Leaching of type 1: Surface leaching with no erosion and no water pressure gradient (Fig. I.1)

In *dense* concrete and with *no water pressure gradient* (like in a completely submerged concrete member) the reaction between water and concrete only occurs at the outer surface of the structure. This means that the dissolution process occurs as a *moving boundary* and is diffusion controlled. Water diffusing further into the concrete than the dissolved zone will be saturated by lime and, therefore, it cannot dissolve any more lime. The growth of the thickness of the dissolved zone is determined by the amount of dissolvable lime, the diffusivity of dissolved lime and the gradient in lime concentration across the dissolved zone as shown by the following derivation³.

The transport of dissolved matter in the dissolved layer is described by Fick's law, assuming the gradient being linear between the surrounding water and the leaching front; see Fig. I.1:

$$dM = \{ \delta_m \cdot A \cdot (c_0 - c_s) / x \} \cdot dt \quad (I.1)$$

³ G. Fagerlund: Calculation of the service life of concrete structures. Div. of Building Materials, Lund Institute of Technology, Lund Institute of Technology. Report TVBM-3070, 1996 (In Swedish)

where dM is the amount of transported dissolved lime [kg]
 δ_m is the diffusivity of dissolved material in the dissolved zone [m^2/s]
 A is the cross-section perpendicular to the flow [m^2]
 c_0 is the concentration of dissolved material in the surrounding water
 (normally zero) [kg/m^3]
 c_s is the saturation concentration (the solubility) of material in water
 (=concentration at the leaching front) [kg/m^3]
 x is the depth of the dissolved zone [m]
 dt is the exposure time [s]

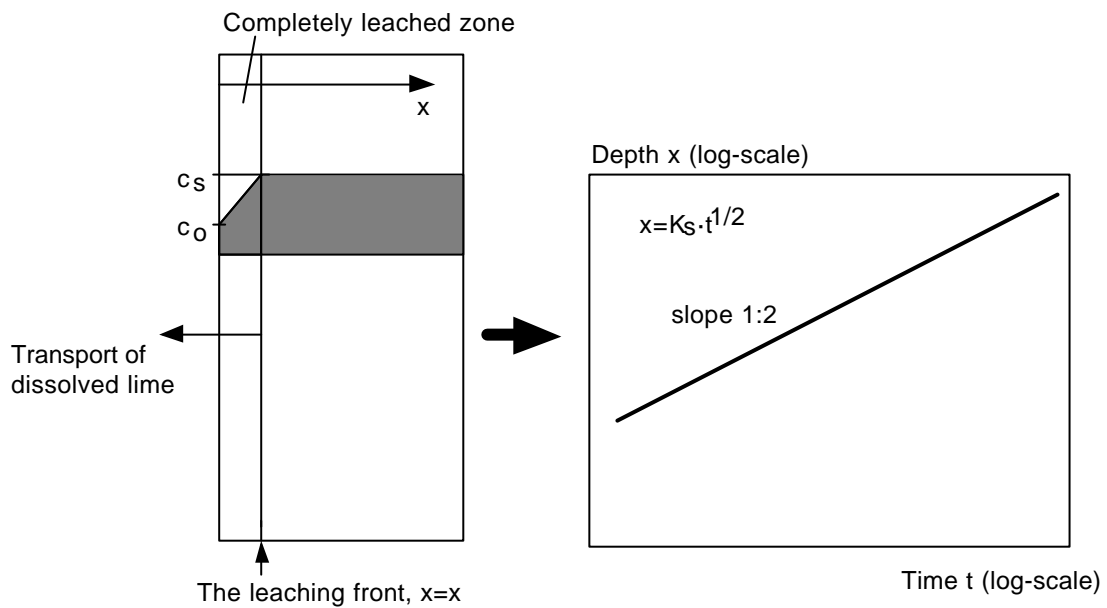

Figure I.1: Leaching of type 1; surface leaching with no erosion and no pressure gradient.

The dissolved amount during the time interval dt is

$$dM = M_V \cdot A \cdot dx \quad (I.2)$$

where M_V is the total amount of soluble material [kg/m^3 of concrete]

Combining eqn. (I.1) and eqn. (I.2) gives

$$x = \{(2 \cdot \delta_m (c_0 - c_s) / M_V)\}^{1/2} \cdot t^{1/2} = K_S \cdot t^{1/2} \quad (I.3)$$

where K_S is a constant [$m/s^{1/2}$]

The thickness of the dissolved zone evidently is proportional to the square-root of time, provided there is no surface erosion. Concrete with high amount of lime, like concrete with limestone aggregate, will have a slower dissolution rate than concrete with acid aggregate since the value of M is higher. An example of leaching of type 1 is shown in Fig. I.2⁴.

The amount of lime leached after time t from 1 m² of exposed concrete surface is

$$Q = x \cdot M_v = K_s \cdot M_v \cdot t^{1/2} \quad (I.4)$$

where Q is the total dissolved lime after time t [kg/m²]

The leaching rate will increase if water outside the concrete is moving, because then the "counter-concentration" c_0 will approach zero. If the outer water is stagnant, its concentration of lime will gradually increase, whereby the dissolution rate will gradually decrease. After some time dissolution might even come to a halt.

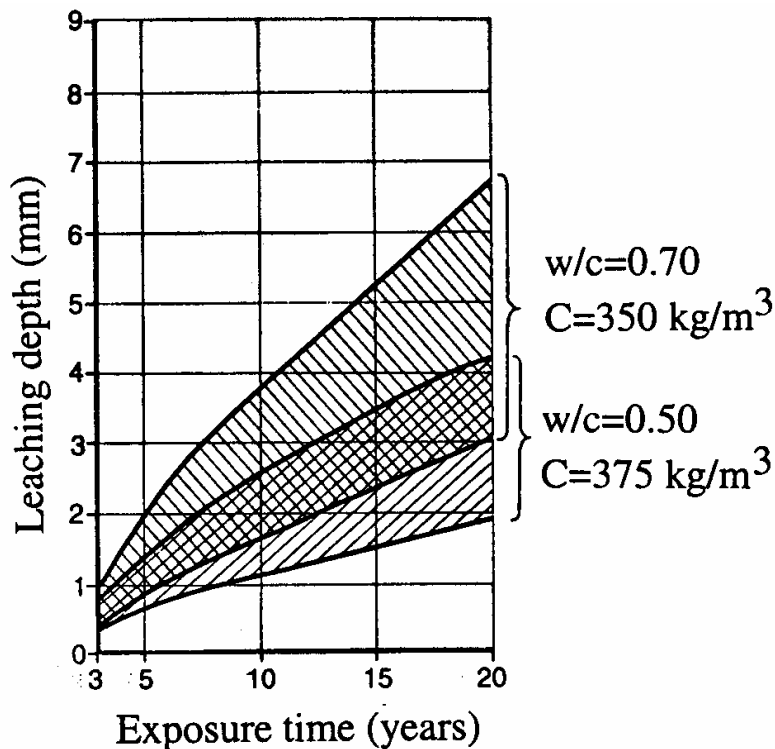

Figure I.2: Example of leaching of type 1. The leaching depth of concrete exposed to water containing 100 mg aggressive CO₂ per litre and pH 5.6.

⁴ F.W. Locher & S. Sprung: Die Beständigkeit von Beton gegenüber kalklösender Kohlensäure. Beton 7/75, 1975

The diffusion-controlled dissolution occurs as long as lime is the only substance that is leached. Also the other compounds in cement paste, such as hydration products of aluminates and ferrite, have a certain solubility, although very much lower than that of the other calcium compounds like CSH gel and Ca(OH)_2 . Sooner or later, however, when the dissolved zone has become thick enough, the rate of dissolution of the less soluble substances will become just as high as the dissolution of the more easily soluble lime products. Then the leaching process will become linear with time. An example of the beginning of such a transition from a square-root relation to a linear relation is seen in Fig. I.3⁵.

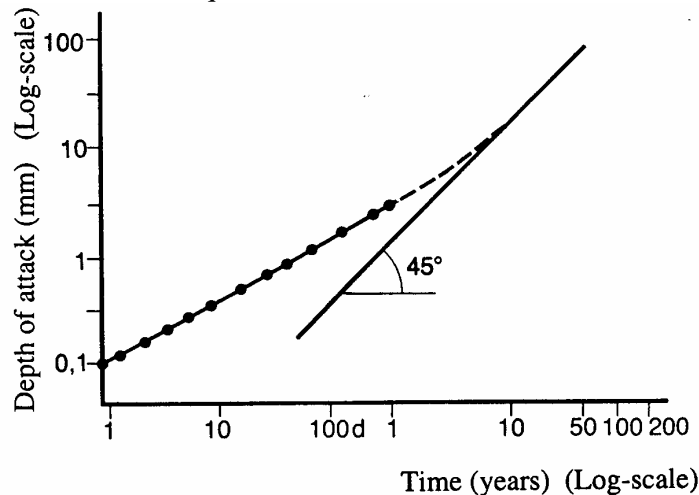

Figure I.3: Example of leaching (in hydrochloric acid with pH 3.1) gradually going over to a linear attack when the more insoluble components in cement paste are attacked. The transition is calculated theoretically.

I:2.3 Leaching of type 2: Surface leaching as in type 1, but with erosion (Fig. I.4)

If water is streaming along the concrete surface by high speed, and if it brings with it sand and other erosive particles, the dissolved and thereby weakened surface layer can be eroded by about the same rate as leached concrete is formed. When this occurs, the leaching process will become more or less linear. Concrete of good quality will not be significantly eroded by streaming water unless the surface is weakened, for example by leaching.

⁵ L. Rombén: Aspects on testing methods for acid attack on concrete - further experiments. Swedish Cement and Concrete Research Institute, Research Fo2:79, 1979.

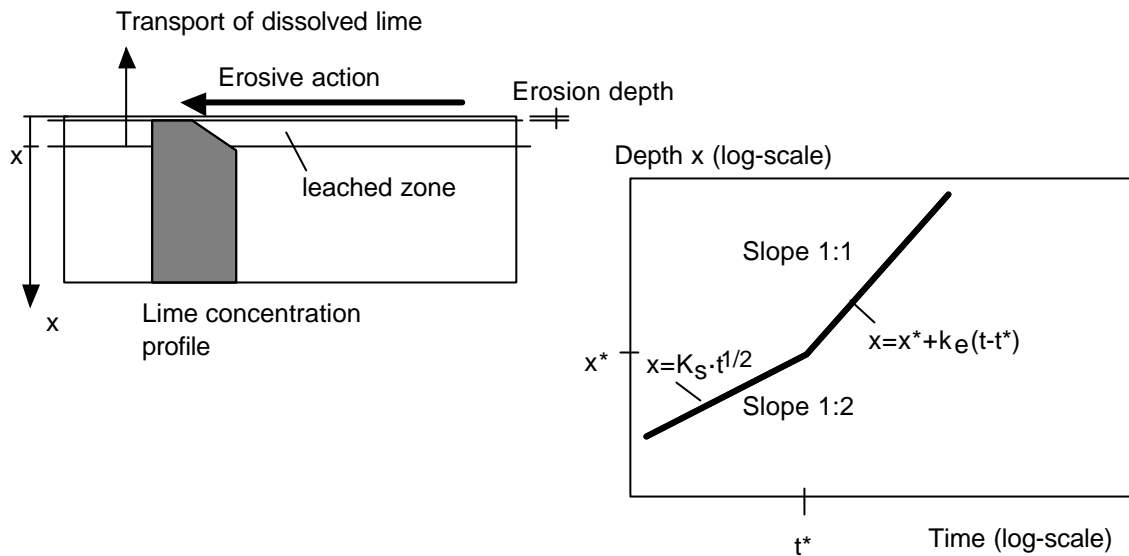

Figure I.4: Leaching of type 2; surface leaching with erosion but no pressure gradient.

The erosion rate is supposed to be constant

$$dx_e/dt = k_e \quad (I.5)$$

where dx_e/dt is the rate of erosion depth [m/s]
 k_e is a coefficient determined by the erosive effect [m/s]

The leaching process will become linear when the rate of erosion is equal to the rate of penetration of the leached front. This is found by derivation of eqn. (I.3).

$$dx/dt = \delta_m(c_o - c_s)/(M \cdot x) \quad (I.6)$$

The leaching rate after this time is described by

$$x = x^* + k_e(t - t^*) \quad (I.7)$$

where x^* is the depth of the leaching front when the erosion rate is equal to the rate of penetration of the leaching front [m]
 t^* is the time when this happens [s]

x^* and t^* are obtained by putting the erosion rate according to eqn. (I.5) equal to the rate of penetration of the leaching according to eqn. (I.6):

$$x^* = \delta_m(c_o - c_s)/M_V \cdot k_e \quad (I.8)$$

$$t^* = \delta_m(c_o - c_s)/(2 \cdot M_V \cdot k_e^2) \quad (I.9)$$

The total amount of dissolved lime after time t is

$$Q = x \cdot M_v = \{x^* + k_e(t - t^*)\} M_v \quad (\text{I.10})$$

where Q is the total amount of dissolved lime after time t [kg/m²]
 M_v is the total amount of soluble material [kg/m³ of concrete]

Another type of erosion is *cavitation* due to water streaming with very high speed, such as in a spillway in a concrete dam. This, however, is a phenomenon of its own which gives very big erosive damage also to unleached concrete. Therefore, it is not treated here.

I:2.4 Leaching of type 3: Homogeneous internal leaching with water pressure gradient (Fig. I.5)

I:2.4.1 Requirements for homogeneous leaching

In the case of *highly permeable*, uncracked and defect-free concrete exposed to a *water pressure gradient* across its thickness, water can be assumed to flow homogeneously over the entire concrete volume, which means that all lime in the concrete member stays in direct contact with flowing water. Water will of course become more saturated by lime the deeper it has penetrated into the structure. Thus, also in the case of a structure exposed to penetrating water one might assume a sort of moving boundary, although less pronounced than in dense concrete not exposed to a water pressure gradient. This "quasi-homogeneous" case is treated as leaching of type 4.

It has been observed in real structures, however, that almost all parts of the structure is leached in cases where leaching is a real problem, viz. in highly permeable concrete with high w/c-ratio, exposed to water penetrating the structure due a hydraulic head at one side. This implies that the rate of dissolution of lime in such concrete is slower than the rate by which water flows through the structure. This means that one might, as a first approximation, assume that every water unit has the same lime-soluble ability no matter of where in the structure it is in contact with a pore wall; may it be at the upstream part of the structure or at the downstream part.

Only *convective* leaching by which is meant lime removal by flowing water is considered. A certain *diffusive* leaching might also occur, but it ought to be negligible in highly permeable concrete.

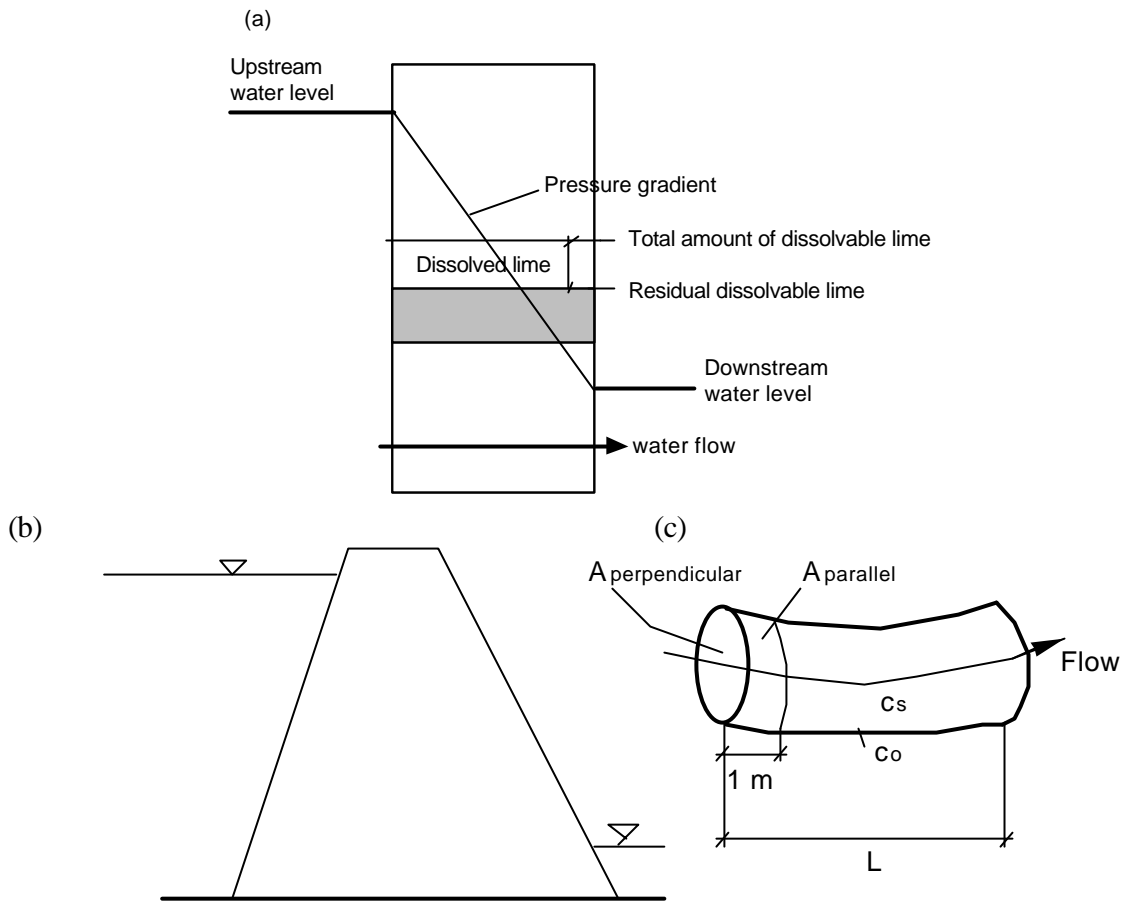

Figure I.5: (a) Leaching of type 3; homogeneous leaching. (b) Streamlines and equipotential lines. (c) Definition of a "streamline tube".

The rate of dissolution of lime from the pore wall is; see Fig. I.5(b)⁶

$$dM'/dt = k(c_s - c_o) \quad (I.11)$$

where dM'/dt is the rate of dissolution of lime [$\text{kg}/(\text{m}^2 \text{ pore area} \cdot \text{s})$]
 c_s is the saturation concentration of dissolved lime (i.e. the lime concentration of pore water in contact with the pore wall) [$\text{kg}/\text{m}^3 \text{ pore water}$]
 c_o is the concentration of dissolved lime in streaming water inside the pore [$\text{kg}/\text{m}^3 \text{ pore water}$]
 k is a rate-determining constant [$\text{m}^3 \text{ pore water}/(\text{m}^2 \text{ pore area} \cdot \text{s})$]

⁶ This equation implies that all types of lime in concrete is dissolved by the same rate. In reality, there are at least three different "time constants" k ; one rather high for dissolution of $\text{Ca}(\text{OH})_2$, one smaller for CSH and one still smaller for CaCO_3 , aluminate and ferrite. This means that the requirement for homogeneous dissolution over the entire cross-section is different for different types of dissolution. A higher water flow is required for homogeneous leaching of $\text{Ca}(\text{OH})_2$ than for homogeneous leaching of CSH; see eqn. (I.18).

The total rate of dissolution from all pore walls in a concrete "streamline tube" with constant cross-section stretching through the entire structure with its axis in the centre of a streamline of water flow is (see Fig. I.5(c))

$$dM/dt = (dM'/dt) \cdot A_{\text{parallel}} \cdot A_{\text{perpendicular}} \cdot L = k(c_s - c_o) \cdot A_{\text{parallel}} \cdot A_{\text{perpendicular}} \cdot L \quad (\text{I.12})$$

where dM/dt is the rate of dissolution of lime from the entire streamline tube considered [kg/s]
 A_{parallel} is the total exposed pore surface parallel to the water flow in 1 m³ of the streamline tube [m²/m³]
 $A_{\text{perpendicular}}$ is the cross-section of the streamline tube perpendicular to the water flow [m²]
 L is the length of the streamline tube [m]

This equation shows that no more lime is dissolved when the pore water is saturated. Therefore, new non-saturated water has to flow to the site of dissolution if this is to continue.

The velocity of water in all parts of the structure (steady state conditions) is v [m/s]. The cross-section of water flow in the streamline tube as fraction of the total cross-section of the tube is equal to the "permeable" porosity P . Thus, the volumetric water flow in the streamline tube is

$$V_w = v \cdot A_{\text{perpendicular}} \cdot P \quad (\text{I.13})$$

where V_w is the volumetric water flow in the concrete [m³/s]
 P is the permeable porosity [m³ pore volume/m³ concrete volume]

Then, the flux of dissolved lime dM/dt [kg/s] becomes

$$dM/dt = V_w \cdot c_o = v \cdot A_{\text{perpendicular}} \cdot P \cdot c_o \quad (\text{I.14})$$

But, the pore surface A_{parallel} is inversely proportional to the hydraulic radius of the pore

$$A_{\text{parallel}} = P/r_h \quad (\text{I.15})$$

where r_h is the hydraulic radius of the pore system ($r_h = r/2$ for cylinder pores) [m]

By comparing eqn. (I.12) for the rate of dissolution of lime, and eqn. (I.14) for the removal of lime, and using eqn. (I.15), a criterion is obtained for when the dissolution of lime is slower than the removal of lime, i.e. the criterion for homogeneous leaching over the entire streamline volume.

$$v > k(c_s/c_o - 1) \cdot (L/r_h) \quad (\text{I.16})$$

The mass water flux per m^2 of the *concrete area* is proportional to the volumetric water flux V_w which in turn is proportional the water speed v . It is also proportional to the water density (1000 kg/m^3).

$$q_w = V_w \cdot 1000 / A_{\text{perpendicular}} = v \cdot P \cdot 1000 \quad (\text{I.17})$$

where q_w is the mass water flux *per m^2 concrete area* [$\text{kg/m}^2 \cdot \text{s}$]

Inserting this expression in eqn. (I.16) gives the following requirement for homogeneous leaching in the entire volume of a structure

$$q_w > P \cdot 1000 \cdot k \cdot (c_s / c_0 - 1) \cdot (L / r_h) \quad (\text{I.18})$$

The equation shows that the condition for homogeneous leaching is more likely to be fulfilled the thinner the structure (expressed by L) and the more slow the dissolution process (expressed by k). Besides the coarser the pore structure (expressed by r_h), the more likely it is that homogeneous leaching occurs. The reason for this is that the surface/volume ratio of pores exposed to the water stream is reduced with increased hydraulic radius.

Theoretically, according to eqn.(I.18), infinite water flux is required when water is completely pure ($c_0=0$). This is a consequence of the assumption behind eqn. (I.14) in which the concentration of lime in the streaming water is assumed to have a finite value. The case $c_0=0$ is trivial, however, because then the condition for homogeneous leaching is automatically fulfilled.

I:2.4.2 The amount of dissolved lime

Leaching of type 3 implies that the degree of leaching is the same over the entire cross-section and that it only depends on the total water flow. Then, the following relation can be applied for the amount of leached lime

$$Q = q_w \cdot s \cdot t \quad (\text{I.19})$$

Where Q is the total amount of dissolved lime [kg/m^2 of concrete area perpendicular to the flow]
 q_w is the water flux [$(\text{kg}/(\text{m}^2 \cdot \text{s}))$]
 s is the average concentration of dissolved lime in the water [kg/kg of water]
 t is the total time of water flow [s]

Note: Since the water flux q_w is different in different parts of the the structure due to different pressure gradients within different "streamline tubes" -see Fig. I.5(a)- the total amount of dissolved lime will be different in different parts of the structure.

I:2.5 Leaching of type 4: Semi-homogeneous internal leaching with water pressure gradient (Fig. I.6)

For *moderately permeable* concrete exposed to a pressure gradient it is reasonable to assume that the water flow is so low that concrete located at the upstream face is dissolved at first while the interior part of the concrete is more or less intact because water is already more or less saturated by lime when it arrives. Thus, leaching should occur as a sort of moving boundary process, but not a true moving boundary process, because dissolution takes some time; see eqn. (I.11). The leaching at a certain depth from the up-stream surface will depend on the water flux, and on the rate of dissolution, as described by eqn. (I.14) and eqn. (I.11).

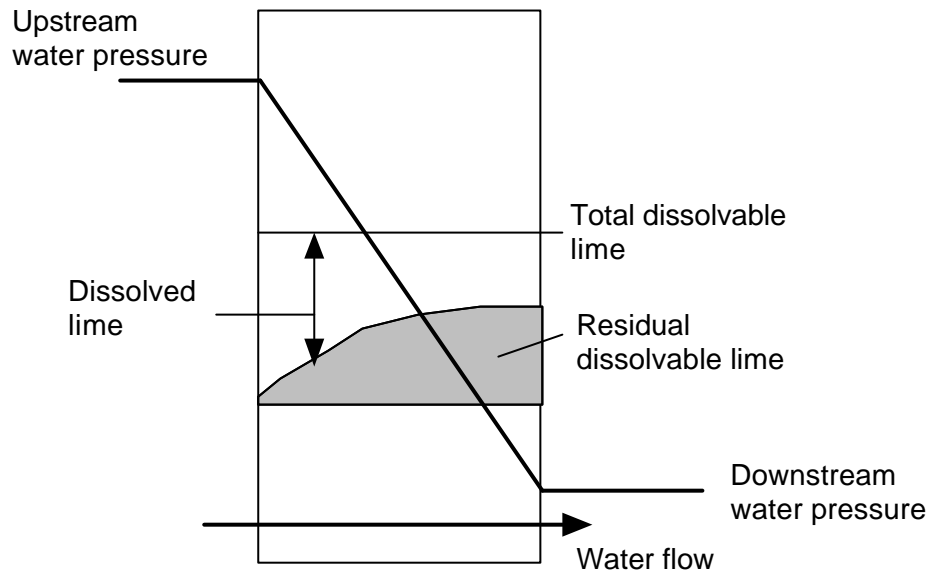

Figure I.6: Leaching of type 4; semi-homogeneous leaching.

Theoretically, the leaching rate at each exposure time t and depth x from the upstream surface, and thereby the leached lime profile at a certain exposure time, could be determined by numerically solving the balance equation for total flow from $t=0$ to $t=t$

$$\int_0^{x,t} (dM'/dt)_{x,t} \cdot A_{\text{parallel}} \cdot A_{\text{perpendicular}} \cdot dx \cdot dt = \int_0^t q_w(t) \cdot A_{\text{perpendicular}} \cdot c(t) \cdot dt \quad [\text{kg}] \quad (\text{I.20})$$

where $(dM'/dt)_{x,t}$ is the rate of dissolution of lime on the depth x at the time t

$[\text{kg}/(\text{m}^2 \text{ pore area} \cdot \text{s})]$; cf. eqn. (I.11)

$q_w(t)$ is the water flux at time t $[\text{kg water}/(\text{m}^2 \text{ concrete area} \cdot \text{s})]$

$c(t)$ is the concentration of lime in out-flowing water at time t $[\text{kg}/\text{kg water}]$

The basic equations to be used for solving eqn. (I.20) are the same as those used for leaching of type 3. But for leaching of type 4 the concentration of lime in the streaming water, required for solving eqn. (I.20), is not the same in all sections x of the streamline tube. The concentration of lime in the streaming water at the depth x is

found by integrating the leaching from $x=0$ to $x=x$. The result of the calculation is a function expressing the amount of leached lime at the depth x after time t .

$$Q=f(x,t) \quad (I.21)$$

As for leaching of type 3 the amount of leached lime will be different in different parts of the structure depending on different values of the water flux in different parts.

I:2.6 Leaching of type 5: Selective leaching in defects and cracks under water pressure gradient (Fig. I.7)

In the previously described leaching types, attack has been assumed to occur over the entire cross-section perpendicular to the flow. It is often found, however, that the flow, and thereby the leaching, is concentrated to certain discrete *flow channels*. The flow channels appear where there is an initial defect, such as in a region of bad compaction, or a crack.

The flow channels become more and more accentuated the longer the exposure time, because the size of the channels increase with increased leaching. The permeability of a cylindrical pore is proportional to the pore radius raised to the fourth power. The increase in the pore radius is directly proportional to the amount of leaching. The leaching is also proportional to the permeability. Thus, the local leaching rate increases *progressively* with time.

A special type of selective leaching occurs at through *cracks*. Water flow in a crack can be assumed to be so big that the "crack water" always has a concentration that is lower than the saturation concentration. As a first approximation it is assumed that the dissolution from the crack wall will occur as a *moving boundary* perpendicular to the wall. Then, the penetration of the dissolution front in the crack wall can be described by eqn. (I.1) expressed

$$z = \{(2 \cdot \delta_m (c_0 - c_s) / M_v)\}^{1/2} \cdot t^{1/2} \quad (I.1)$$

where z is the depth from the crack wall perpendicular to this on which total leaching has occurred [m]
 δ_m is the diffusivity of dissolved lime within the dissolved layer [m^2/s]
 c_s is the saturation concentration of lime [kg/m^3 of water]
 c_0 is the concentration of lime in the "crack water" [kg/m^3 of water]
 t is time [s]
 M_v is the mass of "dissolvable" lime in the concrete [kg/m^3 of concrete]

Measurements, however, indicate that leaching does not occur as a true moving boundary, but with a gradually decreasing dissolution from the crack wall inwards. An example is shown in Fig. I.8⁷. The reason probably is that the diffusion of dissolved lime is a slow process compared with the dissolution reaction itself. This means that the dissolution might be described by the same type of equation as the diffusion of ions in concrete, for example the diffusion of chloride ions; see section III.3.

$$(M_{z,t} - M_{\infty}) / (M_v - M_{\infty}) = \text{erf}\{z / \{2(\delta_m t)\}^{1/2}\} \quad (\text{I.22})$$

Where $M_{z,t}$ is the actual content of dissolvable lime at distance z and time t [kg/m^3]
 M_{∞} is the dissolvable lime content at equilibrium (normally $M_{\infty} > 0$) [kg/m^3]
 M_v is the dissolvable lime content in unleached concrete [kg/m^3]

This equation is solved in exactly the same manner as, for example, the chloride transport equation.

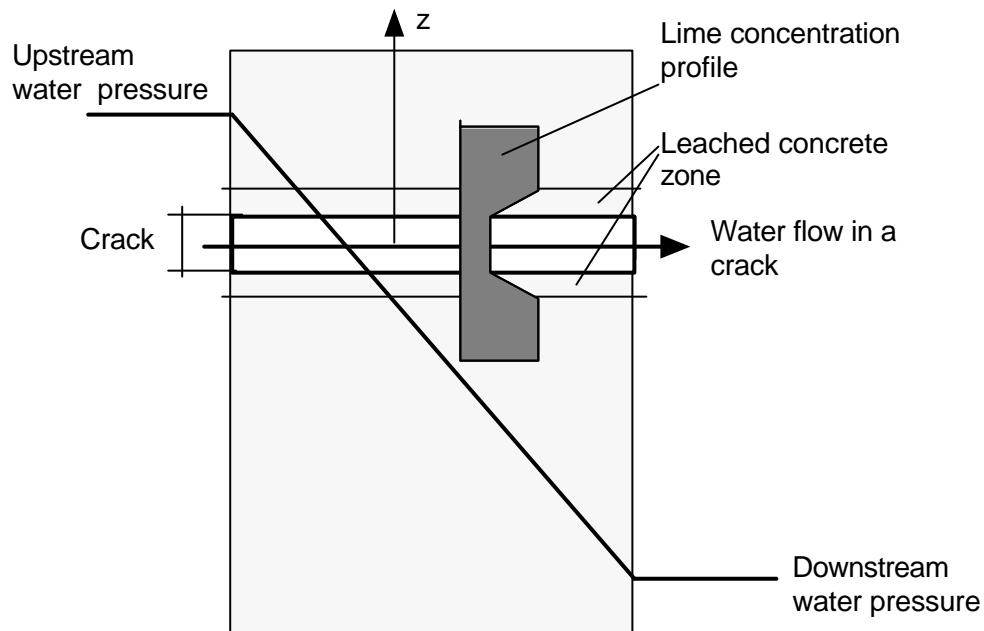

Figure I.7: Leaching of type 5; selective leaching in defects.

⁷ U.A.Halvorsen: Corrosion and leaching of lime in cracked concrete structures. Div. of Building Technology, Lund Institute of Technology. Bulletin No 1, 1966. (In Swedish)

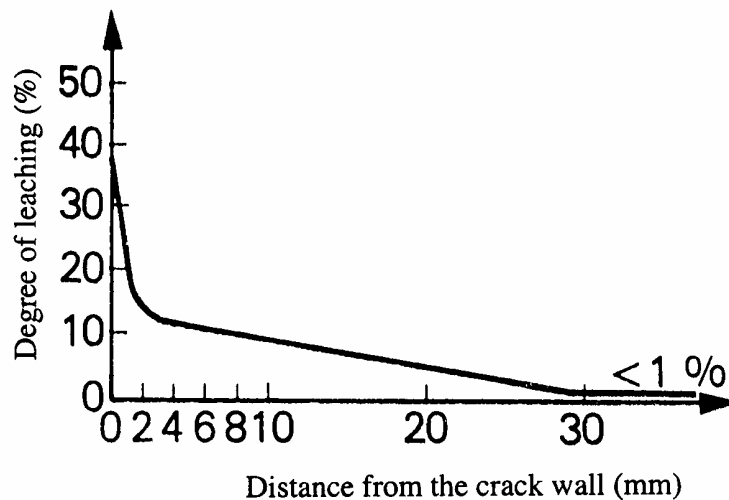

Figure I.8: Degree of leaching as function of the distance from the crack wall. 100% corresponds to total leaching of all CaO in the cement.

In reality, dissolution seems to be the average between a moving boundary and a diffusive process. The dominating process probably depends on the permeability of the concrete. According to Fig I.8 the ratio M_{∞}/M_0 seems to be about 0,60 which means

that only about 40% of all lime is dissolvable, which is about 50% of all lime that emanates from hydrated cement; see paragraph I:1.2. The rest of the lime is located to unhydrated cement and, therefore, it is almost completely insoluble.

It must be observed that the water flow in a crack (or other defect) is much higher than the flow in the bulk concrete. The water flux in a through crack with the length B and the width T in a structure with the thickness L parallel to the water flow is

$$Q_v = (T^3 \cdot B / 12 \cdot \mu) \cdot (\Delta P / L) \quad (I.23)$$

where Q_v is the volumetric flow in the crack [m^3/s]
T is the width of the crack [m]
B is the length of the crack [m]
L is the thickness of the structure [m]
 μ is the viscosity of water [$\approx 10^{-3} \text{ Ns/m}^2$]
 ΔP is the pressure difference over the crack [Pa]

For a 1 m long crack with the width 0.1 mm in a structure that is 1 m thick exposed to a pressure difference of 10 m water head [10^5 Pa] the annual water flow is 260 000 kg. This can be compared with water flow through 1 m^2 of uncracked normal concrete, which is only 150 kg (assuming the permeability $B = 5 \cdot 10^{-12} \text{ [s]}$). Therefore leaching in cracks will be very rapid.

Besides, when the crack is widened due to leaching, the water flow is progressively increasing since the flow is proportional to the width in cube.

I:3 Relation between water flow and dissolution

According to eqn. (I.19) leaching is directly proportional to the water flow through the concrete. This in turn is determined by the permeability of the concrete.

A concrete member with water pressure on one side and no water pressure on the other side is considered. It is assumed that equilibrium conditions prevail and that the pressure gradient is linear across the thickness of the member. This means that the permeability coefficient is assumed to be constant. This assumption is reasonable since concrete that is sensitive to leaching is very permeable which means that permeation (flow under over-pressure) dominates over diffusive flow.⁸

Water flow at steady state conditions is described by

$$q_w = B \cdot (\Delta P / \Delta x) \quad (I.24)$$

where q_w is the mass water flux [kg/(m²·s)]
 B is the permeability [s]
 $\Delta P / \Delta x$ is the pressure gradient [Pa/m]

Liquid water flow is often expressed as a volumetric flow, and the pressure gradient is expressed in m water head. Thus, the transport equation is

$$q_{w,v} = K \cdot (\Delta P_v / \Delta x) \quad (I.24')$$

where $q_{w,v}$ is the volumetric water flow [m³/(m²·s)]
 K is the permeability [m/s]
 $\Delta P_v / \Delta x$ is the pressure gradient [m water head/m]

$B=1$ [s] corresponds to $K=10$ [m/s]

The total lime leached from the concrete volume of a "streamline tube" with a given pressure gradient and with 1 m² cross-section is

$$Q = q_w \cdot s \cdot t = B \cdot (DP/Dx) \cdot s \cdot t = K \cdot (DP_v/Dx) \cdot s \cdot t \quad (I.25)$$

where Q is the total amount of lime leached [kg/m²]
 s is the average concentration of lime in the flowing water; cf. eqn. (I.19)
 [kg/kg of water]

⁸ In dense concrete diffusive flow and permeation occurs simultaneously. Permeation dominates at the upstream part of the concrete and diffusion at the downstream part. This combined flow is sometimes called "wicking". It can be treated theoretically; see G.Fagerlund: Calculation of the service life of concrete structures. Div. of Building Materials, Lund Institute of Technology. Report TVBM-3070. Lund 1996 (In Swedish)

Relations between the permeability and the water-cement ratio of un-leached concrete are shown in Fig. I.9. The permeability is highly dependent of the aggregate size, probably because of the porous interfaces between coarse aggregate and cement paste.

Data from Fig. I.9 can be used for approximate calculations of water flow and leaching. For more accurate calculations the permeability of the actual concrete should be determined by forcing water under pressure through a disc of the concrete. It is important to wait until steady state conditions are reached, which might take a very long time for dense concrete. Such concrete, however, is not sensitive to leaching.

The water flux is different in different parts of the structure since the pressure gradient is different. In order to calculate the amount of leaching it is therefore necessary to make a calculation of the pressure field in the structure. Also, the permeability will normally be different in different parts of the structure. Therefore, instead of using the pressure field and permeability in eqn. (I.24) it is more reliable to measure the real water flux in different parts.

Because of leaching, the permeability will gradually increase. This will significantly affect the future leaching. Therefore, the increase in permeability is of big importance for the prediction of the future deterioration. This is treated in section II.1.

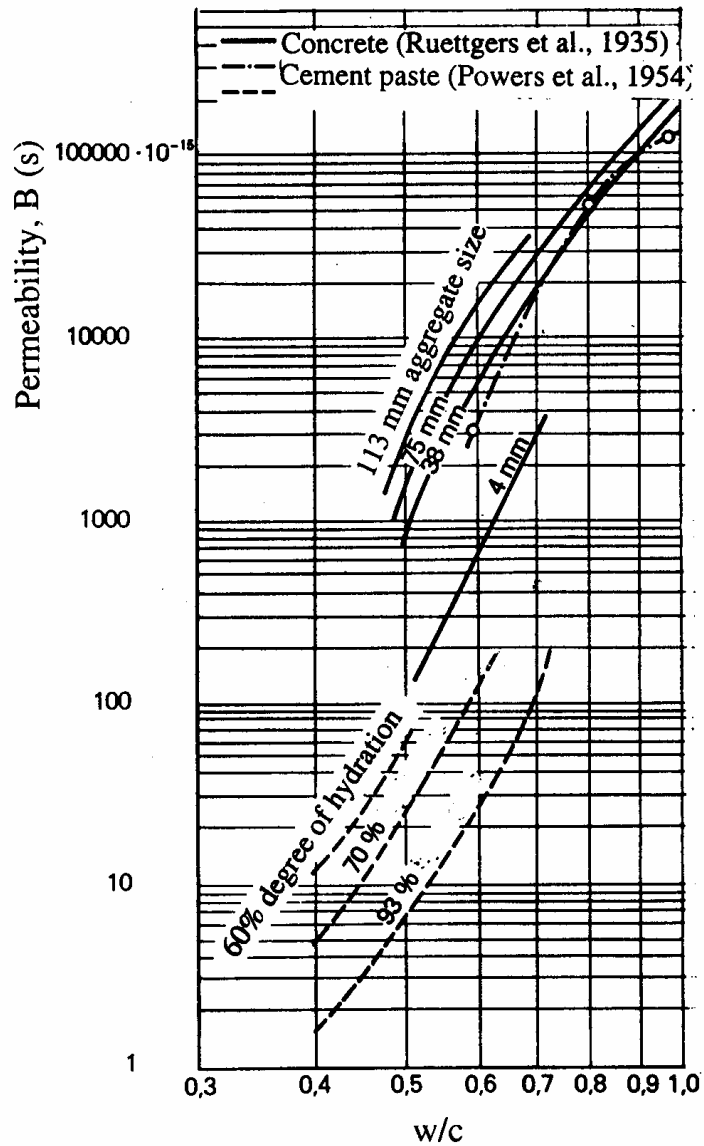

Figure I.9: Relation between the w/c-ratio and the water permeability defined by eqn. (I.24). Effect of the aggregate size. Data from different authors⁹.

⁹ Data from different sources collected in G. Fagerlund: Moisture mechanical properties of concrete. In Concrete Handbook, Stockholm 1980.

¹⁰ J. Crank: The Mathematics of Diffusion. Clarendon Press, Oxford, 1985.

II: Extrapolation of deterioration

II:1 Extrapolation of water flow and dissolution

II:1.1 Surface leaching of type 1

Within the leached part of the concrete total leaching can be supposed to have occurred. Thus, the loss of lime can be as high as 85 weight-%, or 70 vol-% of the cement paste weight or volume (section I:1). The actual amount of leaching can be determined experimentally by chemical analysis.

The total leaching at the exposure time t is proportional to the depth of penetration of the leaching front, x

$$Q=x \cdot M_v \quad (\text{II.1})$$

where Q is the amount of leached lime [kg/m^2]
 x is the penetration depth of the leaching front [m]
 M_v is the amount of dissolvable lime [kg/m^3]

The leaching front is located to the depth x_0 from the surface at the time of inspection t_0 . Therefore, the coefficient K_s in eqn. (I.3) is

$$K_s=x_0/t_0^{1/2} \quad (\text{II.2})$$

The location of the penetration front after time t is

$$x=x_0(t/t_0)^{1/2} \quad (\text{II.3})$$

And, the total amount of leaching after time t is

$$Q=x_0(t/t_0)^{1/2} \cdot M_v=Q_0 \cdot (t/t_0)^{1/2} \quad (\text{II.4})$$

where Q_0 is the amount of leaching at the time of inspection [kg/m^2]

$$t=t_0+\Delta t \quad (\text{II.5})$$

where Δt is the additional time after inspection [s]

Therefore, eqn. (II.4) can also be expressed

$$Q=Q_0(1+D t/t_0)^{1/2} \cdot M_v \quad (\text{II.4})$$

This equation can be used for time extrapolation of leaching.

II.1.2 Surface leaching of type 2

Within the leached part dissolution is supposed to be total. The leaching front is located to the depth x_0 from the surface at the time of inspection t_0

The total amount of dissolved lime after time t is (see eqn. (I.10))

$$Q=x \cdot M_v=[x^*+k_e(t-t^*)] \cdot M_v \quad (\text{I.10})$$

where Q is the total amount of dissolved lime [kg/m^2]
 M_v is the total amount of dissolvable lime in the concrete [kg/m^3]
 x^* is the dissolution depth when the erosion rate equals the penetration rate of dissolution [m]
 t^* The time corresponding to x^* [s]

This equation can also be expressed in terms of the amount of dissolved lime at the time of inspection, Q_0

$$Q=[x^*+k_e(t-t^*)]/[x^*+k_e(t_0-t^*)] \cdot Q_0 \quad (\text{II.6})$$

Or, by inserting eqn. (II.5)

$$Q=[x^*+k_e(t_0+D t-t^*)]/[x^*+k_e(t_0-t^*)] \cdot Q_0 \quad (\text{II.6}')$$

This equation can be used for time extrapolation of leaching.

II:1.3 Homogeneous leaching of type 3

In the real case, water flow is not constant. Leaching of the *bulk* concrete will increase its permeability. This means that the leaching rate is gradually increased with time. Therefore, the gradual decrease in strength loss will be even more rapid than if the leaching rate was constant; Fig II.3. In the most simple case, leaching is not supposed to change the pore size distribution, but only the porosity. In this case, the permeability is directly proportional to leaching. Probably, leaching will also cause a coarsening of the pore system. Therefore, the permeability will increase progressively with the amount of leaching. This case can be treated theoretically provided the relation between the amount of leaching and the permeability is known. Some possibilities of considering the effect of leaching on permeability are presented below.

II:1.3.1 No change in permeability due to leaching

The water flux is supposed to be uninfluenced by leaching. Then, the rate of leaching can be assumed to be constant and equal to the rate of leaching at the time of inspection.

The average leaching rate until the time of inspection is

$$dQ/dt=Q_0/t_0 \quad (II.7)$$

where dQ/dt is the rate of leaching from the "streamline tube" [kg/(m²·s)]
 Q_0 is the total amount of lime leached from "a streamline tube" with
the cross-section 1 m², during the exposure time $t=0$ until $t=t_0$
[kg/m²]. Definition of a "streamline tube" is given in Fig. I.5(c).
 t_0 is the time of inspection

This means that the total leaching at time t , or at the additional time Δt , is

$$Q=Q_0 \cdot t/t_0=Q_0(1+D t/t_0) \quad (II.8)$$

The total leaching cannot be higher than the amount of lime in the concrete, When this condition is reached no further leaching will occur.

The total leaching expressed in volume of concrete is

$$Q_v=Q/L \quad (II.9)$$

where Q_v is the total leaching in 1 m³ of the concrete [kg/m³]
 L is the length of the "streamline tube" [m]

If the leaching in a unit volume somewhere inside the structure is determined experimentally at the time of inspection, extrapolation can be made in the same way as for total leaching (eqn. (II.8))

$$Q_v=Q_{v,0} \cdot t/t_0=Q_{v,0}(1+D t/t_0) \quad (II.8')$$

where $Q_{v,0}$ is the total leaching in the unit volume at the time of inspection
[kg/m³]

Eqn. (II.8') is used for extrapolation of the future leaching. The only information needed is the amount of leaching at the time of inspection.

The total leaching as function of time can also be calculated from measurements of the water flux and lime concentration in the out-flowing water.

$$Q=B \cdot (\Delta P / \Delta x) \cdot s \cdot t \quad (I.24)$$

where s is the concentration of lime in the out-flowing water [kg/kg of water]
 B is the permeability defined by eqn. (I.24) [s]
 $\Delta P / \Delta x$ is the pressure gradient [Pa/m]

The permeability is obtained from the water flux at inspection

$$B=q_{w,o} \cdot (\Delta x / \Delta P) \quad (I.23)$$

Then, the leached lime per m^3 of concrete, Q_v after the time t is found by inserting eqn. (I.24) in eqn. (I.25) and using the relation (II.9)

$$Q_v \cdot L=q_{w,o} \cdot s \cdot t=q_{w,o} \cdot s \cdot (t_0+Dt) \quad (II.10)$$

where L is the length of the "streamline tube" [m]
 $q_{w,o}$ is the water flux at the time of inspection [$kg/m^2 \cdot s$]
 s is the lime concentration in the outflowing water [kg/kg]

A prerequisite for the extrapolation is that there is no change in the pressure gradient due to leaching and that the leaching rate from the pore walls is constant.

II:1.3.2 Gradual increase in permeability due to leaching

In the normal case, the permeability will not remain constant but will increase with increasing time because of leaching. Exactly how leaching affects permeability is unknown. A simplified analysis is made below.

The virgin concrete has an average permeability B_i defined by eqn. (I.24). After leaching the average permeability has increased to B .

(a) The permeability is directly proportional to leaching

The permeability is, as first approximation, supposed to be directly proportional to the permeable porosity. This means that the ratio between the permeability B and B_i is

$$B/B_i=[1-(X_i-DX_Q)]/(1-X_i)=1+DX_Q/(1-X_i) \quad (II.11)$$

where X_i is the initial volume fraction of the non-permeable ("solid") phase in the cement paste [m^3/m^3]
 ΔX_Q is the decrease in X caused by leaching [m^3/m^3]

Note: $1 - X_i = P_i$ which is the initial permeable porosity.

The dissolved volume is proportional to the dissolved weight.

$$\Delta X_Q = v_s \cdot Q_V \quad (II.12)$$

where v_s is the specific volume of the dissolved solid material [m^3/kg]
 Q_V is the total amount of dissolved lime per m^3 of concrete [kg/m^3]

Inserting ΔX_Q from eqn. (II.12) into eqn. (II.11) gives the following coefficient of permeability as function of the total water flow

$$B = B_i [1 + v_s \cdot Q_V / (1 - X_i)] \quad (II.13)$$

The water flux is (see eqn. (I.24))

$$q_W = B \cdot \Delta P / \Delta x = B_i [1 + v_s \cdot Q_V / (1 - X_i)] \cdot (\Delta P / \Delta x) \quad (II.14)$$

where $\Delta P / \Delta x$ is the pressure gradient in water [Pa/m]

The total lime leached from 1 m^2 cross-section of the entire "streamline tube" until time t is

$$Q_V \cdot L = \int_0^t q_W \cdot s \cdot dt = \int_0^t B_i [1 + v_s \cdot Q_V(t) / (1 - X_i)] \cdot (DP/Dx) \cdot s \cdot dt \quad (II.15)$$

where s is the solubility of lime; cf. eqn. (I.19) [kg/kg of water]
 L is the length of the streamline tube [m]

$Q_V(t)$ is a non-linear time function of the amount of dissolved lime. The non-linearity depends on the gradually increased leaching. This equation must be solved numerically.

Eqn. (II.15) is used for calculation of the amount of lime dissolved until the time of inspection

$$Q_{V,0} \cdot L = \int_0^{t_0} B_i [1 + v_s \cdot Q_V(t) / (1 - X_i)] \cdot (\Delta P / \Delta x) \cdot s \cdot dt \quad (II.16)$$

where $Q_{V,0}$ is the total amount of lime dissolved at the time of inspection [kg/m^3]
 t_0 is the time of inspection [s]

The water flux at the time of inspection is

$$q_{w,0} = B_i [1 + v_s \cdot Q_{v,0} / (1 - X_i)] \cdot (\Delta P / \Delta x) \quad (\text{II.17})$$

where $q_{w,0}$ is the water flux at the time of inspection [kg/(m²·s)]

From this equation the initial permeability, B_i can be expressed in terms of the water flow and degree of leaching at the time of inspection. This value of B_i is inserted in eqn. (II.16). It is assumed that the pressure gradient is uninfluenced by leaching (a somewhat questionable assumption, since leaching might radically change the pressure field inside the structure, see section III.5). Then, eqn. (II.16) can be rewritten

$$Q_{v,0} [(1 - X_i) + v_s \cdot Q_{v,0}] L = \int_0^{t_0} q_{w,0} [(1 - X_i) + v_s \cdot Q_v(t)] \cdot s \cdot dt \quad (\text{II.16}')$$

The leaching $Q_{v,0}$, the concentration of dissolved lime s , and the water flux $q_{w,0}$ at the time of inspection are determined by measurements on the structure. Then, eqn. (II.16') can be used for determination of the function $Q_v(t)$, i.e. the time process of leaching.

Eqn. (II.15) can then be used for estimating the future dissolution by inserting the function $Q_v(t)$ obtained by eqn. (II.16'). The initial permeability determined by eqn. (II.14) is also inserted in the equation. In this way eqn. (II.15) is transformed into

$$Q_v \cdot L = \int_0^t q_{w,0} \cdot \left\{ \frac{[(1 - X_i) + v_s \cdot Q_v(t)]}{[(1 - X_i) + v_s \cdot Q_{v,0}]} \right\} \cdot s \cdot dt \quad (\text{II.15}')$$

Information required for extrapolation using eqn. (II.15') is the lime concentration in the outflowing water, s , the water flux at the time of inspection, $q_{w,0}$ and the initial porosity, $P_i = 1 - X_i$. The extrapolation principles are illustrated in Fig. II.1.

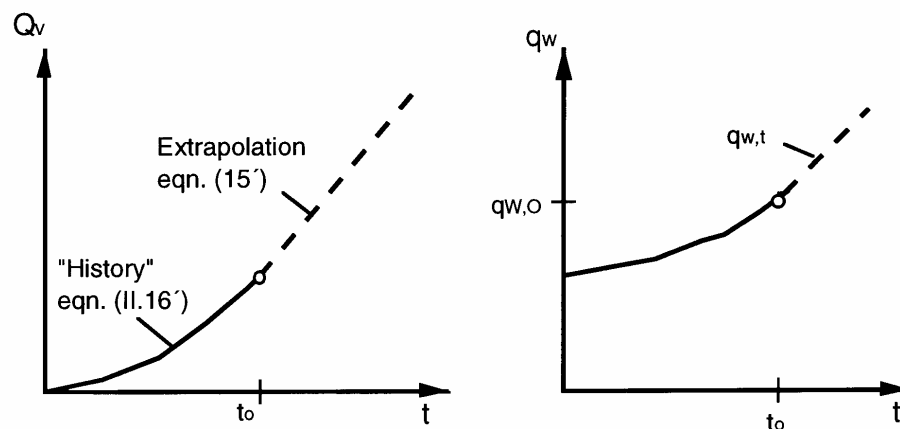

Fig II.1: Time extrapolation of leaching -principles.

(b) The permeability is progressively increasing with increased leaching

A linear relation between leaching and permeability might be too conservative. It is just as easy to assume a permeability that is progressively increasing with increasing amount of leaching. A possible relation between the actual permeability and the initial permeability is

$$B/B_i = (1 - X_i + \Delta X_Q)^k / [1 - X_i]^k = [1 + \Delta X_Q / (1 - X_i)]^k \quad (\text{II.18})$$

In which the exponent $k > 1$.

The total lime leached is

$$Q_V \cdot L = \int_0^t B_i [1 + v_s \cdot Q_V(t) / (1 - X_i)]^k \cdot (DP/Dx) \cdot s \cdot dt \quad (\text{II.19})$$

The equation is solved numerically.

By using information of the water flux, $q_{w,0}$, and total amount of dissolved lime $Q_{v,0}$ at the time of inspection, t_0 , eqn. (II.19) is transformed into (cf. the derivation of eqn. (II.16').)

$$Q_{v,0} [(1 - X_i) + v_s \cdot Q_{v,0}]^k \cdot L = \int_0^{t_0} q_{w,0} [(1 - X_i) + v_s \cdot Q_V(t)]^k \cdot s \cdot dt \quad (\text{II.20})$$

From this equation the time function $Q_V(t)$ is derived and inserted in eqn. (II.19)

$$Q_V \cdot L = \int_0^t q_{w,0} \left\{ \frac{[(1 - X_i) + v_s \cdot Q_V(t)]}{[(1 - X_i) + v_s \cdot Q_{v,0}]} \right\}^k \cdot s \cdot dt \quad (\text{II.19}')$$

This equation can be used for extrapolation of the future leaching. Like in eqn. (II.15') the pressure gradient is assumed to be uninfluenced by leaching.

(c) The permeability is a function of time

A simplification is to assume that permeability increases linearly with time

$$B = B_i + a \cdot t \quad (\text{II.21})$$

where a is a constant [-]

Then the total lime leached after time t is

$$Q_V \cdot L = \int_0^t (B_i + a \cdot t) \cdot (DP/Dx) \cdot s \cdot dt = [B_i \cdot t + a \cdot t^2/2] \cdot (DP/Dx) \cdot s \quad (II.22)$$

The water flux at the time of inspection is

$$q_{w,0} = (B_i + a \cdot t_0) \cdot (\Delta P / \Delta x) \quad (II.23)$$

From which the initial permeability can be solved

$$B_i = q_{w,0} \cdot (\Delta x / \Delta P) - a \cdot t_0 \quad (II.24)$$

Inserting this in eqn. (II.22) and using the integration limit t_0 gives

$$Q_{v,0} \cdot L = [q_{w,0} \cdot t_0 - 0,5 \cdot a \cdot t_0^2] \cdot (\Delta P / \Delta x) \cdot s \quad (II.25)$$

From this equation the "time factor" a can be solved

$$a = [q_{w,0} \cdot t_0 - Q_{v,0} \cdot L / s] \cdot (\Delta P / \Delta x) / (0,5 \cdot t_0^2) \quad (II.26)$$

This equation used in eqn. (II.22) gives

$$Q_V \cdot L = q_{w,0} \cdot s \cdot (t^2 / t_0 - t) + Q_{v,0} \cdot L [2(t/t_0) - (t/t_0)^2] \quad (II.27)$$

This equation is easily solved analytically. It makes possible a calculation of the future leaching. The parameters $q_{w,0}$ and $Q_{v,0}$ are obtained at the inspection at time t_0 . Like in equations (II.10), (II.15) and (II.19) the pressure gradient is supposed to be uninfluenced by leaching.

II:1.4 Semi-homogeneous leaching of type 4

An approximate extrapolation can be made according to the same principles as for leaching of type 3. The most simple extrapolation is to assume that leaching within each part of the structure will continue with exactly the same rate as before the inspection. This means that permeability is supposed to be unchanged

In this case, the total leaching on the depth x from the upstream surface after the additional time Δt is

$$Q_{v,x} = Q_{v,x,0} \cdot t / t_0 = Q_{v,x,0} (1 + \Delta t / t_0) \quad (II.27)$$

where $Q_{v,x}$ is the total leaching on the depth x [kg/m³]
 $Q_{v,x,0}$ is the leaching on depth x at the time at inspection, t [kg/m³]
 t_0 is the time at inspection

II.1.5 Selective leaching of type 5

The extrapolation will be different for different types of defects.

Probably, leaching of lime from *crack walls* will mainly be determined by diffusion within the dissolved layer, and not by the rate of water flow in the crack itself. The crack width might gradually increase with time, however, which might cause a gradually increased water flow. This might cause trouble downstream not related to the concrete itself, such as corrosion of machinery in a generator hall in a water power station. Besides, an increased water flow might lead to a lower concentration of OH-ions in the "crack water" which might be detrimental to reinforcement steel crossing the crack; see section III.3 below.

(a) *Moving boundary*

Possibly eqn. (I.3) can be used for extrapolation. This means that the total increase in the width of the leached crack is described by

$$Dd = 2 \cdot z \cdot t^{1/2} = 2 \cdot z_0 (1 + \Delta t / t_0)^{1/2} \quad (\text{II.28})$$

where Δd is the increase in the crack width [m]
 z_0 is the thickness of dissolved concrete in the crack wall at time t_0 [m]
 z is the the thickness of the dissolved concrete at time t [m]
 Δt is the additional time after time of inspection, t_0 [s]
 The factor 2 expresses the fact that there are two walls

The total amount of dissolved lime from the crack is

$$Q_c = A_c \cdot 2 \cdot z \cdot M_v \quad (\text{II.29})$$

where A_c is the total surface area of one crack wall parallel to the water flow [m²]
 Q_c is the total amount of dissolved lime from the entire crack [kg]
 M_v is the total amount of dissolvable lime in the concrete [kg/m³]

The total leaching can also be expressed by

$$Q_c = Q_{c,0} \cdot (t/t_0)^{1/2} = Q_{c,0} \cdot (1 + \Delta t / t_0)^{1/2} \quad (\text{II.30})$$

where $Q_{c,0}$ is the total amount of leached lime from the entire crack at the time of inspection [kg]
 Δt is the time after inspection

Provided the water flow in the crack is constant the amount of lime can also be calculated from the measured water flux and its content of lime

$$Q_c = q_{cw,0} \cdot s \cdot t = q_{cw,0} \cdot s \cdot (t_0 + Dt) \quad (II.31)$$

where $q_{cw,0}$ is the water flux in the crack at the time of inspection, t_0 [kg/s]
 s is the amount of dissolved lime in the out-flowing water [kg/kg]

(b) *Leaching of the crack wall by "Fickian diffusion"*

Fig. (I.8) indicates that the leaching from the crack wall does not follow a simple moving boundary process, but merely a diffusive process according to Fick's second law; see eqn. (I.22). Then, the total amount of dissolved lime from both crack walls after time t is¹⁰

$$Q_c = A_c \cdot 4 \cdot (M_v - M_\infty) \cdot (\delta_m \cdot t / p)^{1/2} = A_c \cdot 4 \cdot (M_v - M_\infty) \cdot (\delta_m \cdot (t_0 + Dt) / p)^{1/2} \quad (II.32)$$

where M_v is the total amount of dissolvable lime [kg/m³]
 M_∞ is the amount of dissolvable lime left in the concrete when equilibrium between this and the lime concentration of the "crack water" is reached after long time [kg/m³].
 δ_m is the diffusivity of dissolved lime [m²/s]

This equation can be used for extrapolation of the future *total* leaching from the crack walls. The *spatial distribution* of the leaching is found by eqn. (I.22).

II:2 Extrapolation of strength

II.2.1 Effect of leaching on strength

It is assumed that only the cement paste phase is leached, which is a reasonable assumption when the aggregate is non-calcareous.

Leaching causes strength loss. Concrete strength is mainly determined by the strength of the cement paste phase. A certain relative loss in cement paste strength therefore gives the same relative loss in concrete strength¹¹.

$$f_c = k \cdot f_p \quad (\text{II.33})$$

$$Df_c / f_c = Df_p / f_p \quad (\text{II.34})$$

where f_c is concrete strength (compressive or tensile)
 f_p is cement paste strength (compressive or tensile)
 Δf_c and Δf_p are losses in strength

Approximately, the strength of the *cement paste* is

$$f \approx f_0 X^3 \quad (\text{II.35})$$

where f is the strength [Pa]
 f_0 is the strength of the load-bearing phase in the cement paste [Pa]
 X is the volume fraction of load-bearing phase in the cement paste [m^3/m^3]

An application of this simple relation to cement paste and concrete is shown in the APPENDIX.

Leaching decreases the volume of load-bearing phase inside the cement paste. Thus, strength loss caused by leaching might be described by

$$Df / f_i = 1 - (1 - D X / X_i)^3 \quad (\text{II.36})$$

where Δf is the strength loss [Pa]
 f_i is the initial strength of cement paste before leaching [Pa]
 ΔX is the volume of leached load-bearing material in cement paste [m^3/m^3]
 X_i is the volume of load-bearing phase in unleached cement paste [m^3/m^3]

¹¹ In reality, the relation between cement paste strength and concrete strength is a bit different for different strength levels. The cement paste strength is proportionally higher for low w/c-ratios and proportionally lower for high w/c-ratios; see the APPENDIX, Table A.2. The effect can however be neglected for the actual purpose. Besides, bond at the interfaces between aggregate and cement paste modifies the strength ratio between the cement paste and the concrete. The effect of interface bond is limited to about 20%, however.

Thus, if 20% of the initial load-bearing phase is dissolved, strength is reduced by almost 50%.

The relation between the strength after leaching and the initial strength is

$$f/f_i = \{1 - DX/X\}^3 \quad (\text{II.37})$$

Examples of experimental determinations of the relation between the total amount of leaching of lime expressed as leaching of CaO and strength loss is shown in Fig. II.2¹².

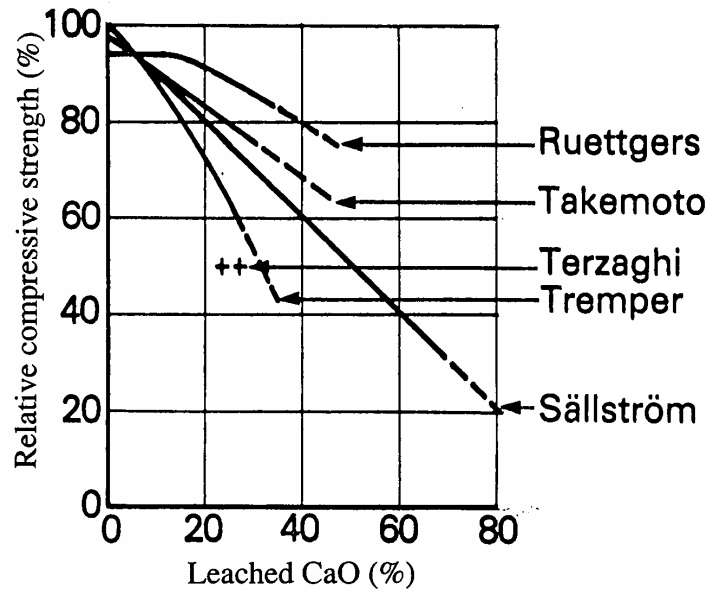

Figure II.2: Strength loss as function of the degree of leaching. Different authors.

If all solid material is supposed to carry load the parameter X will be

$$X = 1 - P \quad (\text{II.38})$$

where P is the total porosity of the cement paste [m^3/m^3].

The value of P increases with increased leaching. The initial porosity P_i is a function of the w/c-ratio and the degree of hydration¹³

$$P_i = (w/c - 0.19 \cdot \alpha) / (w/c + 0.32) \quad (\text{II.39})$$

where P_i is the initial porosity of the cement paste before any leaching [m^3/m^3]

α is the degree of hydration [-]

w/c is the water-cement ratio [-]

¹² U.A.Halvorsen: Corrosion and leaching of lime in cracked concrete structures. Div. of Building Technology, Lund Institute of Technology. Bulletin No 1, 1966. (In Swedish)

¹³ Derived from equations in T.C. Powers: Physical properties of cement paste. In "Chemistry of Cement", Proc. 4th Int. Symposium, Washington, 1960. National Bureau of Standards, Monograph 43, Vol II, Washington D.C. 1962.

However, according to measurements by Grudemo¹⁴ no, or only a fraction, of the calcium hydroxide contributes to strength. Therefore, part of the volume of Ca(OH)₂ should not be included in X.

Therefore, the initial load-bearing phase is

$$X_i = 1 - (P_i + \beta \cdot V_{CH,i}) \quad (\text{II.38})$$

where P_i is the initial porosity of unleached cement paste [m³/m³]
 $V_{CH,i}$ is the initial volume of calcium hydroxide in unleached cement paste [m³/m³]
 β is the volume fraction of calcium hydroxide not contributing to strength

And, the loadbearing phase after leaching is

$$X = 1 - (P_i + V_{CH,l} + V_{CSH,l}) \quad \text{for } V_{CH,l} > \beta \cdot V_{CH,i} \quad (\text{II.39})$$

where $V_{CSH,l}$ is the volume of leached solid CSH-gel [m³/m³]
 $V_{CH,l}$ is the volume of leached Ca(OH)₂ [m³/m³]

Ca(OH)₂ is dissolved at first. Thereafter, when the residual amount of Ca(OH)₂ has reached a certain level, cement gel is gradually decomposed into Ca(OH)₂ which is dissolved.

Therefore, it is reasonable to assume that no strength loss occurs until the gel starts to decompose. This means that one might have a rather large lime dissolution without any accompanying strength loss. This is verified by the measurements by Ruettgers shown in Fig II.2. About 15% of the lime has to be dissolved before strength is affected. This corresponds to about 10% of the cement weight, or almost all of the initially formed Ca(OH)₂; i.e. the coefficient β seems to be about 1 in that experiment.

Assuming that all Ca(OH)₂ has to be dissolved before CSH starts to dissolve and that no Ca(OH)₂ takes load, the volume of load-bearing phase is

$$X = 1 - (P_i + V_{CH,i}) \quad \text{for } V_{CSH,l} = 0 \quad (\text{II.40a})$$

$$X = 1 - (P_i + V_{CH,i} + V_{CSH,l}) \quad \text{for } V_{CSH,l} > 0 \quad (\text{II.40b})$$

The initial volume fraction of Ca(OH)₂ in the cement paste is

$$V_{CH,i} \approx v_{CH} \cdot 0.3 \cdot \alpha / (w/c + 0.32) \quad (\text{II.41})$$

¹⁴ Å. Grudemo: Strength versus structure in cement pastes. Swedish Cement and Concrete Research Institute, Report 13:75, 1975.

where $V_{CH,i}$ is the initial volume fraction of $\text{Ca}(\text{OH})_2$ [m^3/m^3 of cement paste]
 v_{CH} is the specific volume of $\text{Ca}(\text{OH})_2$ [*litre/kg*] (≈ 0.4 litre/kg)
 α is the degree of hydration [-]

The initial volume fraction of solid cement gel in the cement paste (exclusive of gel pores and calcium hydroxide) is

$$V_{CSH,i} = v_{CSH} \cdot 0.95 \cdot \alpha / (w/c + 0.32) \quad (\text{II.42})$$

where $V_{CSH,i}$ is the initial volume fraction of solid cement gel [m^3/m^3 cement paste]
 v_{CSH} is the specific volume of solid cement gel [*litre/kg*] (≈ 0.4 litre/kg)

II.2.2 Extrapolation of strength

Even if water flow, and therefore leaching, is constant with time, the strength loss will follow a non-linear development; see eqn. (II.35). At first there is almost no strength decrease until almost all $\text{Ca}(\text{OH})_2$ is dissolved. Thereafter, the strength loss is progressively increasing with time as illustrated in Fig. II.3.

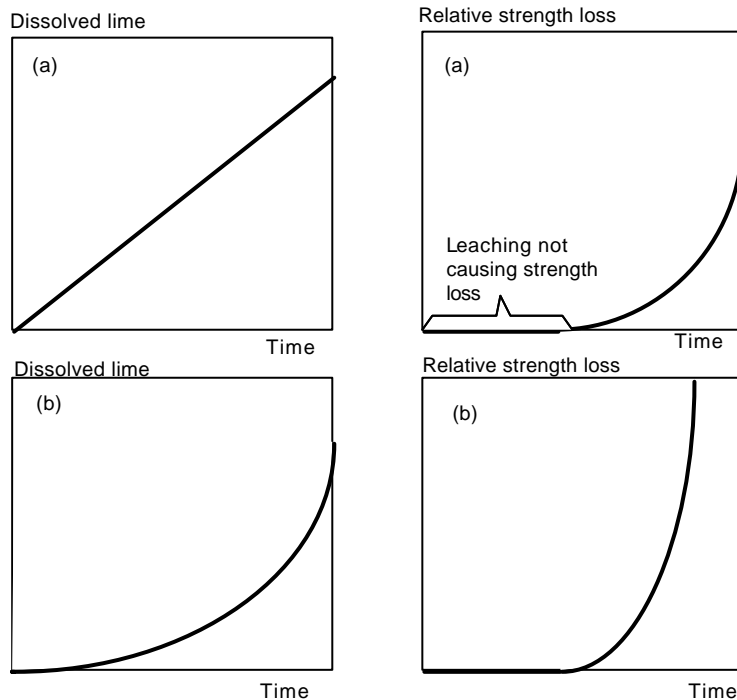

Figure II.3: Time functions of leaching and strength loss; principles.

(a) Permeability is constant.

(b) Permeability increases with increased leaching.

The relation between the relative strength and volume of leached lime is; see eqn. (II.36))

$$\Delta f/f_i = 1 - \{1 - (\Delta X - \Delta X')/X_i\}^3 \quad (\text{II.43})$$

where ΔX is the total volume of dissolved lime [m^3/m^3]
 $\Delta X'$ is the volume of dissolved lime not affecting strength [m^3/m^3]
 X_i is the initial volume fraction of load-bearing phase in the cement paste [m^3/m^3]

$\Delta X'$ is approximately equal to the amount of Ca(OH)_2 in the cement paste; see eqn. (II.38).

The relation between the volume of dissolved lime and the weight of lime is

$$\Delta X = v_s \cdot Q_v \quad (\text{II.12})$$

where Q_v is the weight of dissolved lime per m^3 of concrete [kg/m^3]
 v_s is the specific volume of dissolved lime [m^3/kg]. It is assumed to be the same for all types of lime.

Then, eqn. (II.43) can be written

$$Df/f_i = 1 - \{1 - v_s \cdot (Q_v - Q_v')/X_i\}^3 \quad (\text{II.44})$$

where Q_v is the total amount of leaching in 1 m^3 of concrete [kg/m^3]
 Q_v' is the amount of lime not causing strength loss [kg/m^3]

The residual strength is

$$f/f_i = \{1 - v_s \cdot (Q_v - Q_v')/X_i\}^3 \quad (\text{II.45})$$

Q_v as function of time is given by eqn. (II.10), eqn. (II.15'), eqn. (II.19'), or eqn. (II.22') depending on whether permeability is supposed to be constant or increasing with the amount of leaching, or with time.

II:3 Extrapolation of E-modulus

II:3.1 Effect of leaching on E-modulus

The effect of leaching on the E-modulus can be estimated in about the same way as for strength. In this case there is not simple relation between the E-modulus of the cement paste and the E-modulus of the concrete, however.

The following relation describes the E-modulus of the cement paste¹⁵.

$$E_p = E_{p,o} \cdot X^3 \quad (\text{II.46})$$

where E_p is the E-modulus of the cement paste [Pa]
 $E_{p,o}$ is the E-modulus of the solid phase [Pa]
 X is the volume fraction of solid phase [m³/m³]

This equation is similar to the equation for strength, eqn. (II.35). However, X in the equation for E-modulus is not the same as X in the equation for strength. In eqn. (II.46) *all* solid phase is included in X . In eqn. (II.35) only the *load-bearing* solid phase is included (cf. eqn. (II.38)).

The initial value of X in eqn. (II.46) is

$$X_i = 1 - P_i \quad (\text{II.47})$$

where P_i is the initial total porosity of the cement paste [m³/m³]

The E-modulus of the concrete can be estimated by the Hashin formula for a composite material

$$E_c = E_p \cdot \frac{(1 - V_a)E_p + (1 + V_a)E_a}{(1 + V_a)E_p + (1 - V_a)E_a} \quad (\text{II.48})$$

where E_c is the E-modulus of the concrete [Pa]
 E_a is the E-modulus of the aggregate [Pa]
 V_a is the volume fraction of aggregate [m³/m³]

Using this equation, and assuming that all solid phases have the same E-modulus, and that the fraction of aggregate is 70%, the following relation for the effect of leaching on the E-modulus of the concrete is obtained

¹⁵ R.A. Helmuth & D. Turk: Elastic moduli of hardened portland cement and tricalcium silicate pastes. Highway Research Board, Special Report 90, 1966.

$$DE_c/E_{c,i} = 1 - [1 - DX/X_i]^3 \cdot \frac{[0.3(X_i - DX)^3 + 1.7] \cdot [1.7X_i^3 + 0.3]}{[1.7(X_i - DX)^3 + 0.3] \cdot [0.3X_i^3 + 1.7]} \quad (\text{II.49})$$

where ΔE_c is the change in the E-modulus of the concrete [Pa]
 $E_{c,i}$ is the initial E-modulus before leaching [Pa]
 X_i is the initial fraction of solid phase in the cement paste [m^3/m^3]
 ΔX is the loss in solid phase due to leaching [m^3/m^3]

For a normal concrete ($w/c=0.60$) the initial porosity of the cement paste is about 50%. Therefore, also X_i is about 0.50. A leaching of 20% of the initial solid phase in the cement paste therefore gives a reduction in the E-modulus of about 35%. The reduction in E-modulus for a given leaching is evidently smaller than the reduction in strength. The reason is that aggregate plays a more significant rôle for the E-modulus of concrete than it does for strength.

II.3.2 Extrapolation of the E-modulus

The relation between the volume of dissolved lime and the weight of lime is

$$\Delta X = v_s \cdot Q_v \quad (\text{II.12})$$

where ΔX is the volume of dissolved solid material [m^3/m^3]
 Q_v is the weight of dissolved lime per m^3 of concrete [kg/m^3]
 v_s is the specific volume of dissolved lime [m^3/kg]. It is assumed to be the same for all types of lime.

Then, eqn. (II.49) can be written

$$DE_c/E_{c,i} = 1 - [1 - v_s \cdot Q_v/X_i]^3 \cdot \frac{[0.3(X_i - v_s \cdot Q_v)^3 + 1.7] \cdot [1.7X_i^3 + 0.3]}{[1.7(X_i - v_s \cdot Q_v)^3 + 0.3] \cdot [0.3X_i^3 + 1.7]} \quad (\text{II.50})$$

where Q_v is the total amount of leaching in 1 m^3 of concrete [kg/m^3]

This equation is used for calculation of the future reduction in E-modulus by inserting the time dependent leaching Q_v .

Q_v as function of time is given by eqn. (II.10), eqn. (II.15'), eqn. (II.19'), or eqn. (II.22') depending on whether permeability is supposed to be constant or increasing with the amount of leaching, or with time.

III: Effect of leaching on the structural stability

III:1 Introduction

The author is not aware of any study dealing with the effect of leaching on the structural stability of a concrete structure. Therefore, only a few remarks are made below about the manner in which structural stability of a leached structure might be considered. The starting point is an investigation of the degree of leaching and strength in crucial parts of the actual structure. On the basis of this information the degree of deterioration is estimated.

The *future* leaching and loss in strength and stiffness are predicted according to the method described in section II.

Also the risk of future reinforcement corrosion and frost attack must be considered.

For a hydraulic structure the uplift due to water pressure is also of extreme importance. The uplift might change due to leaching and, therefore, it has to be considered and used as input for the calculation of the stability of the structure.

By using extrapolated values for the future leaching and strength degradation, and by estimating the effect of leaching on the uplift forces, the future structural stability is calculated; see Fig. III.1.

In the analysis of the structural stability a probabilistic approach must be used as indicated in Fig. III.1.

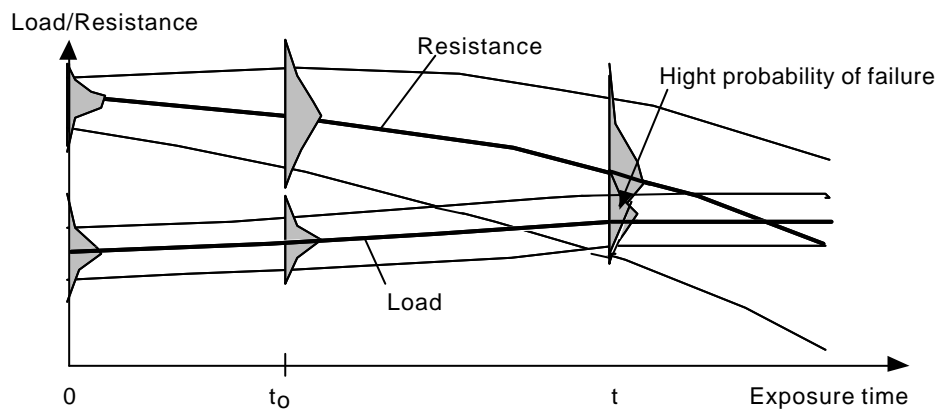

Fig III.1: Extrapolation of the structural stability-principles.

III:2 Concrete strength

III:2.1 Compressive and tensile strength

The compressive and tensile strength is determined on cores taken from strategic parts of the structure at the time of inspection. On the basis of these data, and extrapolated data, characteristic values for the strength can be determined as function of the exposure time, and be used in a normal structural design. Actual data for the load and structural dimensions are used in the calculations. The calculations are made according to a design code specified by the owner; either the currently used national code, or the code used when the structure was erected.

III:2.2 Bond strength

The bond strength between reinforcement and concrete cannot be determined easily. Probably it is related to the compressive and tensile strength. Some measurements of the effect of reduction in strength due to internal frost damage and bond strength have been made¹⁶. Some results are seen in Fig. III.2 and III.3.

The bond is very much influenced by stirrups. The data in Fig. III.2 and III.3 are valid for longitudinal reinforcement without stirrups. When stirrups are present the bond strength is considerably higher.

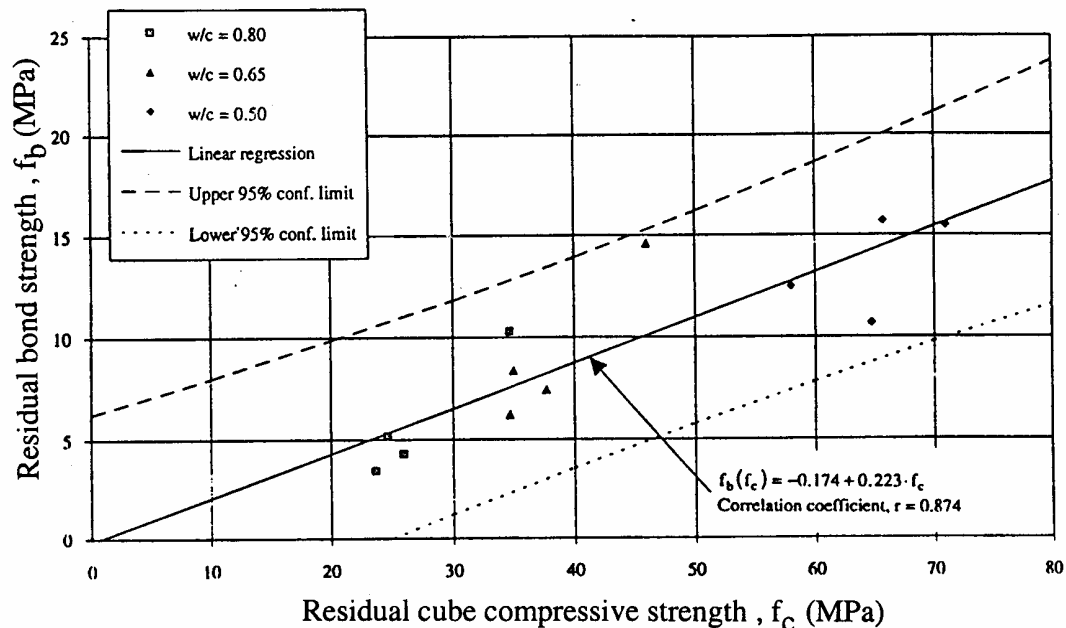

Figure III.2: Relation between the residual compressive strength after internal frost damage, and the residual bond strength.

¹⁶ G. Fagerlund, M. Janz, B. Johannesson: Effect of frost damage on the bond between reinforcement and concrete. Div. Building Materials, Lund Institute of Technology, Report TVBM-9016, 1994.

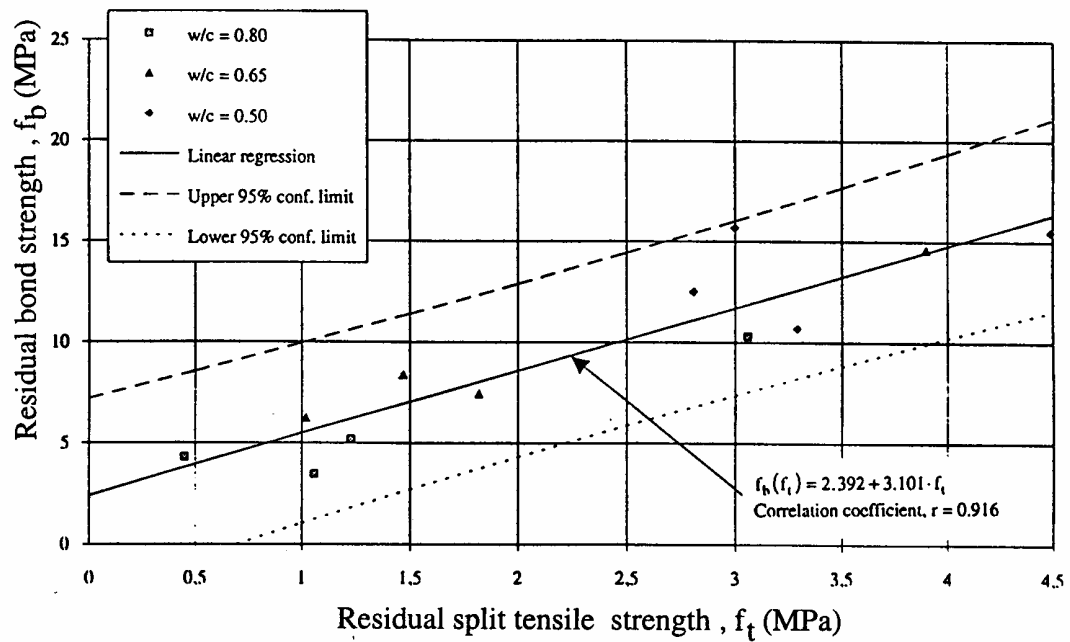

Figure III.3: Relation between the residual split tensile strength after internal frost damage, and the residual bond strength.

The data from Fig. III.2 and III.3 can possibly also be used for a calculation of the structural stability of a leached concrete. Probably the values in the figures can be used for defining a lower bound for bond strength. Therefore, by extrapolating tensile and compressive strength, one also obtains an extrapolation of the bond strength.

III:3 Reinforcement corrosion

III:3.1 Introduction

Reinforcement corrosion starts when the passive conditions around the steel disappears due to carbonation, or due to the influx of chloride ions.

Carbonation is extremely slow in water saturated concrete. Therefore, corrosion due to carbonation should be a minor problem in most hydraulic structures. There are unsaturated parts in such structures, however, where corrosion might be a problem. In such parts leaching should normally be of less importance, however. If leaching has occurred, for example at the downstream face of a lamellae dam, it will increase the carbonation rate, thereby reducing the service life.

Chloride induced corrosion is not relevant for structures placed in normal water. In structures exposed to sea water, that is penetrating the structure, chloride ions will enter the concrete both by convection and diffusion. Leaching will have two negative effects with regard to chloride induced corrosion:

- 1: It increases the permeability to chloride ions
- 2: It reduces the threshold chloride concentration for onset of corrosion

Corrosion of reinforcement steel, that is crossing a crack, has turned out to be a minor problem in hydraulic structures exposed to normal water¹⁷. Leaching will increase the crack width, however, which might make the problem more important.

When corrosion starts, it will affect the structural stability because of reduced cross-section of the reinforcement bars and spalling of the concrete cover¹⁸.

III:3.2 Carbonation

The carbonation rate in a given environment is determined by two factors that are highly influenced by leaching:

- 1: The amount of lime that is able to carbonate
- 2: The permeability of the concrete cover to penetrating carbon dioxide

The carbonation process can be described by the following equation¹⁹

¹⁷ U.A.Halvorsen: Corrosion and leaching of lime in cracked concrete structures. Div. of Building Technology, Lund Institute of Technology. Bulletin No 1, 1966. (In Swedish)

¹⁸ The relation between reinforcement corrosion and structural stability has been studied by J. Rodriguez, J. Casal, L.M. Ortega and J.M. Díez at the company Geocisa, Spain within a BRITE/EURAM project "The Residual Service Life of Concrete Structures". References to their work can be found in a report on the project edited at the Division of Building Materials, Lund Institute of Technology, Report TVBM -7117, 1997.

¹⁹ G. Fagerlund: Calculation of the service life of concrete structures. Div. of Building Materials, Lund Institute of Technology, Lund Institute of Technology. Report TVBM-3070, 1996 (In Swedish)

$$x=[2\cdot\delta_c\cdot c_c/C]^{1/2}\cdot t^{1/2} \quad (\text{III.1})$$

where x is the depth of the carbonation front [m]
 δ_c is the diffusivity of carbon dioxide in the concrete cover [m²/s]
 c_c is the concentration of CO₂ in air surrounding the structure [mole/m³]
 C is amount of material able to carbonate [mole/m³]
 t is the exposure time [s]

The carbonation rate is found by derivation of eqn. (III.1)

$$dx/dt= [\delta_c\cdot c_c/(C\cdot 2)]^{1/2}\cdot t^{-1/2} \quad (\text{III.2})$$

Therefore, the relation between the amount of leached lime and carbonation rate is

$$(dx/dt)_l/(dx/dt)_o=[1/(1-g)]^{1/2} \quad (\text{III.3})$$

where $(dx/dt)_l$ is the carbonation rate of the leached concrete [m/s]
 $(dx/dt)_o$ is the carbonation rate of the unleached concrete [m/s]
 γ is the fraction of total lime that is leached [-]

This means that the carbonation rate is increased by a factor 1.3 when 40% of the lime is leached, and by a factor 1.85 when 70% of the lime is leached.

Eqn. (III.3) implies that the entire cover is leached to the same extent and that the diffusivity of CO₂ is unaffected by leaching.

The effect of leaching on the diffusivity of CO₂ is not known. One simplification is to assume that the diffusivity is directly proportional to the cement paste porosity. This increases in direct proportion to the leaching. Thus the diffusivity is

$$\delta_{c,l}=\delta_{c,o}(1+\Delta P/P_o) \quad (\text{III.4})$$

where $\delta_{c,l}$ is the diffusivity after leaching [m²/s]
 $\delta_{c,o}$ is the diffusivity before leaching [m²/s]
 ΔP is the increase in porosity due to leaching [m³/m³]
 P_o is the porosity before leaching [m³/m³]

The volume of leached material is directly proportional to its weight

$$\Delta P=v_s\cdot Q_v \quad (\text{II.12})$$

where v_s is the specific volume of leached lime [m³/kg]
 Q_v is the weight of dissolved lime [kg/m³]

The leaching process is assessed by equations given in section II.1.

According to eqn. (III.2) the relation between the carbonation rates of the leached and un-leached concrete is

$$\frac{(dx/dt)_l}{(dx/dt)_0} = \left\{ \frac{1 + \Delta P/P_0}{1 - g} \right\}^{1/2} \quad \text{(III.5)}$$

Leaching of all $\text{Ca}(\text{OH})_2$ from the concrete with a w/c-ratio of 0.60 corresponds to an increase in the porosity of about 25%, i.e. $\Delta P/P_0 \approx 0.25$. The fraction of leaching γ is about 40%. Thus, the carbonation rate is increased by a factor of about 1.45 instead of 1.3, a value that is valid if the diffusivity was kept constant; see above.

The increased rate of carbonation means that the time until start of corrosion is reduced in the same proportion. Thus, one can conclude that leaching causes a considerable reduction in the service life with regard to carbonation induced corrosion.

The effect of leaching on carbonation and time to onset of corrosion is illustrated in Fig. III.4.

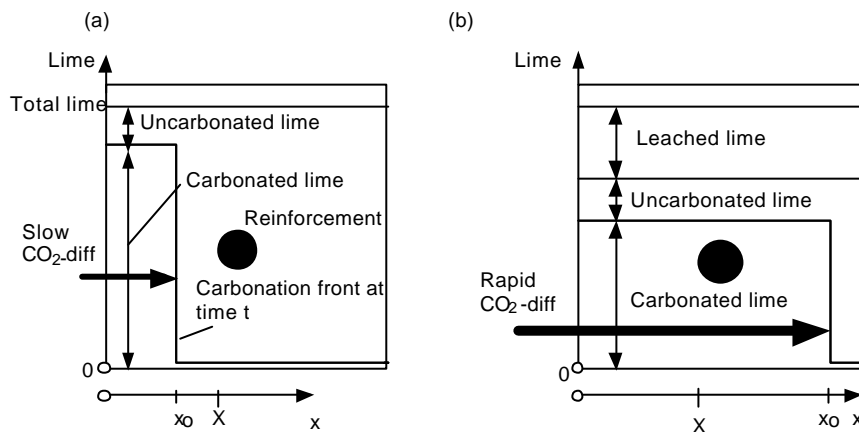

Fig. III.4: Effect of leaching on corrosion induced by carbonation - principles.
(a) Before leaching. (b) After leaching.

III:3.3 Chloride induced corrosion

The service life with regard to chloride induced corrosion can be described by the following equation provided the outer chloride concentration is constant and that the inflow of chloride ions is determined by diffusion with a diffusivity that is unchanged with time²⁰

$$c_{thr}/c_o = \text{erfc}\{X/[4d_{eff}t]^{1/2}\} \quad \text{(III.6)}$$

where c_{thr} is the threshold concentration of free chloride ions [mole/l]
 c_o is the chloride ion concentration at the surface [mole/l]
 X is the concrete cover [m]
 d_{eff} is the effective chloride diffusivity considering chemical and physical binding of chlorides [m^2/s]
 t is the exposure time [s]
 erfc is the complementary error function ($\text{erfc}=1-\text{erf}$)

The effective diffusivity is

$$d_{eff} = \delta/(c_b/c+1) = \delta/(R+1) \quad \text{(III.7)}$$

where δ is the diffusivity not considering chloride binding (i.e. the "steady state diffusivity") [m^2/s]
 c_b is the bound (immobilized) chloride ion concentration [mole/l]
 c is the concentration of chloride that is free to move [mole/l]
 R is the ratio between bound and free chloride [-]

Chloride diffusivity is defined by Fick's law

$$q_c = \delta \cdot d[c]/dt \quad \text{(III.8)}$$

where q_c is the flux of free chloride [mole/($m^2 \cdot s$)]
 δ is the diffusivity of chloride [m^2/s]
 $d[c]/dx$ is the gradient in free chloride concentration [mole/($m^3 \cdot m$)]

An approximate relation for the threshold concentration is given by the Hausmann criterion²¹

$$c_{thr} = 0.6 \cdot [\text{OH}^-] \quad \text{(III.9)}$$

where $[\text{OH}^-]$ is the concentration of OH⁻ ions in the pore solution [mole/l]

²⁰ J. Crank: The Mathematics of Diffusion. Clarendon Press, Oxford, 1985.

²¹ D.A. Hausmann: Steel corrosion in concrete. Materials Protection, Nov. 1967.

The initial OH-concentration before any leaching has occurred depends on the alkalinity of the cement, and on the amount of cement and pore water. It can be calculated by the following equation under the assumption that all pore water dissolves the alkali²²

$$[\text{OH}^-] = 1000 \cdot (\text{Na}^+ / 23 + \text{K}^+ / 39) / (w/c - 0.19 \cdot \alpha) \quad (\text{III.10})$$

where Na^+ is the amount of water soluble Na-ions in the cement [kg/kg cement]
 K^+ ditto for water soluble K-ions [kg/kg cement]
 α is the degree of hydration [-]

Leaching will have many negative effects:

- 1: It will increase the steady state diffusivity δ
- 2: It might decrease the amount of bound chloride, thereby increasing the effective chloride diffusivity δ_{eff}
- 3: It will decrease the alkalinity of the concrete, thereby decreasing the threshold chloride concentration c_{thr}

The effect of leaching on chloride penetration is illustrated in Fig. III.5.

The effect of leaching on the diffusivity and binding of chloride is unknown as far as the author knows. The effect of leaching on the pH-value can be studied by investigations on real structures. An example from the field of the effect of sea water leaching on the pH-value of the concrete cover is shown in Fig. III.6.

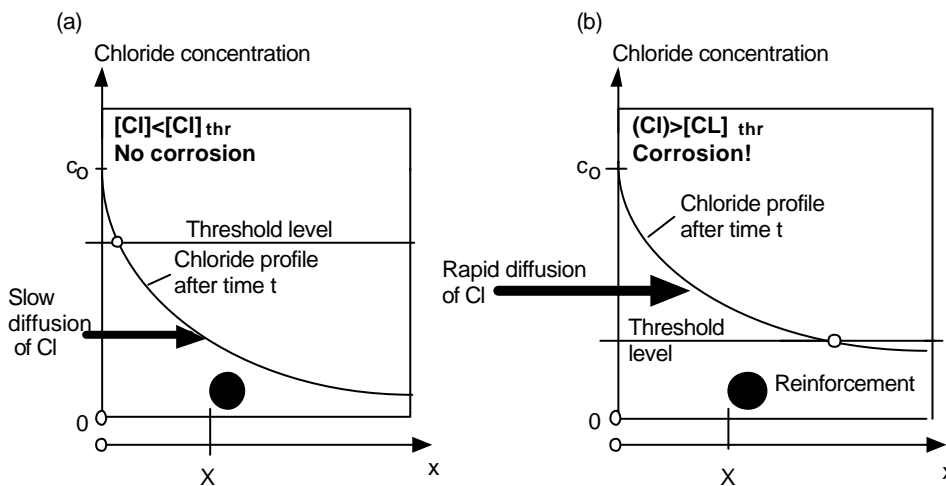

Fig. III.5: Effect of leaching on corrosion induced by chloride - principles
 (a) Before leaching. (b) After leaching

²² K. Tuutti: Corrosion of steel in concrete. Swedish Cement and Concrete Institute, Report Fo 4.82, 1982

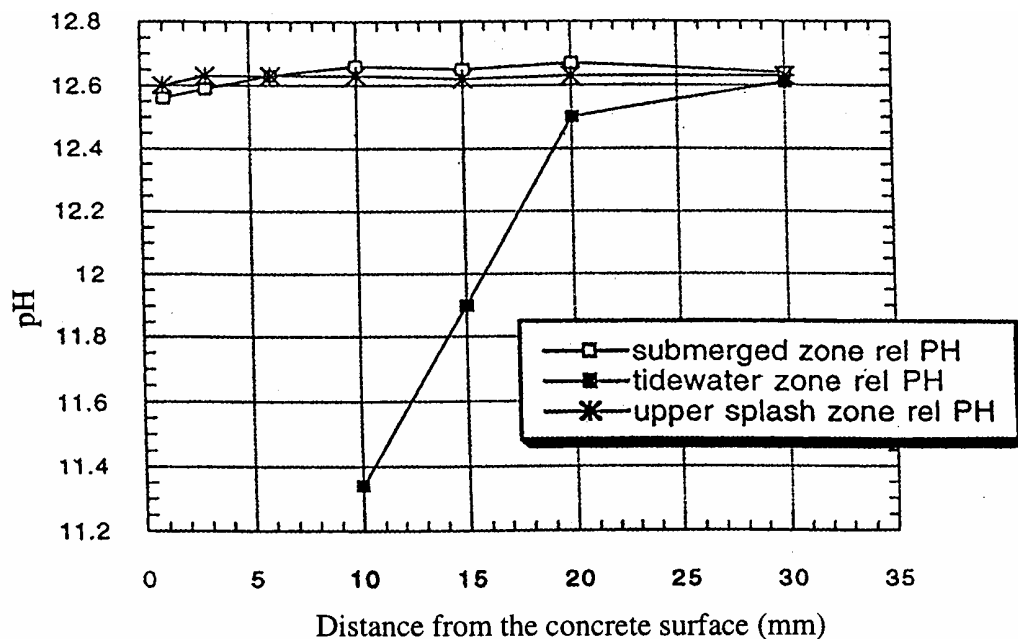

Fig III.6: pH-profiles in a Danish 36 year old quay in sea water²³.

The effect of leaching on the service life with regard to chloride induced corrosion is shown by an example:

A concrete with w/c-ratio 0,5 is considered. The degree of hydration is 0.8. The concrete cover is 45 mm and the concrete structure is placed in the splash zone in sea water.

The cement has a chemical composition that gives $\text{Na}^+=1.5 \cdot 10^{-3}$ kg/kg and $\text{K}^+=9 \cdot 10^{-3}$ kg/kg. $\alpha=0.80$. The effective chloride diffusivity is $\delta_{\text{eff}}=6 \cdot 10^{-12}$ m²/s.

Before leaching:

According to eqn.(III.10) the OH-concentration before leaching is

$$[\text{OH}^-]=1000(1.5 \cdot 10^{-3}/23+9 \cdot 10^{-3}/39)(0.5-0.19 \cdot 0.8)=0.85 \text{ mol/litre}$$

Then, according to eqn. (III.9) the threshold concentration of chloride causing corrosion is $0.6 \cdot 0.85=0.51$ mole/litre.

The sea water has a chloride concentration of 0.46 mole/litre. This means that the chloride concentration in sea water is not high enough to cause corrosion. However, accumulation of chloride at the surface due to repeated splash and drying increases the concentration at the surface by a factor of 1.5 to 0.69 mole/litre.

²³ P. Sandberg: Unpublished results from a field study of a 36 year old concrete quay in Esbjerg, Denmark. Div. of Building Materials, Lund Institute of Technology, 1997.

The exposure time before start of corrosion can now be calculated by eqn. (III.6)

$$0.51/0.69=0.74=\operatorname{erfc}\{0.045/(4\cdot6\cdot10^{-12}\cdot t)^{1/2}\}$$

The value 0.74 corresponds to $\operatorname{erfc}(0.28)$. Thus the time t is calculated by

$$0.28=0.045/(4\cdot6\cdot10^{-12}\cdot t)^{1/2}$$

which gives

$$t=1.07\cdot10^9 \text{ s} = \mathbf{34 \text{ years}}$$

After leaching:

Leaching reduces the pH-value to 12.3 corresponding to pH of saturated $\text{Ca}(\text{OH})_2$ -solution; see Fig.

III.6. This corresponds to $[\text{OH}^-]=0.020$ mole/litre. Thus, the threshold concentration $c_{\text{thr}}=0.6\cdot0.020=0.012$ mole/litre.

The time before corrosion is

$$0.012/0.69=0.017=\operatorname{erfc}\{0.045/(4\cdot6\cdot10^{-12}\cdot t)^{1/2}\}$$

The value 0.017 corresponds to $\operatorname{erfc}(1.7)$. Thus, the time t is calculated by

$$1.7=0.045/(4\cdot6\cdot10^{-12}\cdot t)^{1/2}$$

which gives

$$t=2.9\cdot10^7 \text{ s} = \mathbf{0.9 \text{ years}}$$

The example shows that leaching in saline water will have a very negative effect on the service life with regard to reinforcement corrosion. In normal cases, however, the corrosive atmosphere is not so high since the oxygen concentration is low in saturated concrete. Therefore, the corrosion rate is low, and in many cases negligible.

III.3.4 Corrosion in cracks

Reinforcement bars transverse a crack might corrode, provided the pH-value at the bar is below the threshold value causing corrosion, or provided the chloride content in water in the crack is above the threshold value. Leaching will gradually increase the crack width, thereby increasing the risk of corrosion. However, the crack is normally saturated by flowing water, and normally this is saturated by lime from the leached concrete, i.e. the pH-value is so high that corrosion cannot occur. Thus, reinforcement corrosion in saturated cracks free of chloride is not very likely. This has also been observed in field studies²⁴.

For structures in sea water corrosion in cracks is more likely since it can occur also when the pH-value is high. The risk of chloride induced corrosion increases with the crack width. For cracks below 0.2 mm the risk is small. Leaching will however increase the crack width so that corrosion might start. As shown by eqn. (I.23) the leaching rate in cracks is much more rapid than in the bulk concrete. Therefore, corrosion in cracks in leached concrete, placed in saline environment, must be considered in analyses of the structural stability. The future rate of corrosion must also be considered in such analyses.

²⁴ U.A.Halvorsen: Corrosion and leaching of lime in cracked concrete structures. Div. of Building Technology, Lund Institute of Technology. Bulletin No 1, 1966. (In Swedish)

III:4 Frost attack

III:4.1 Different types of frost attack

There are two types of frost attack²⁵ :

- 1: Internal frost attack leading to loss in cohesion of the concrete.
- 2: Surface scaling due to a combined effect of frost and salt solution from de-icing salt or sea water.

For hydraulic structures only internal frost damage is significant. For some structures, like concrete pillars in sea water, also salt-frost attack can be a problem.

III:4.2 Internal frost attack

The internal frost resistance of concrete is determined by two factors²⁶ :

- 1: The *critical water content* which is mainly a function of material properties.
- 2: The *actual water content* which is a function both of the material structure (mainly the air-pore volume and the air-pore structure) and environmental properties, mainly the "wetness" of the environment.

The risk of frost damage is calculated by²⁷

$$R = \int_0^{W_{\text{saturated}}} F(W_{\text{crit}}) \cdot f(W_{\text{act}}) \cdot dW \quad (\text{III.11})$$

where R is the risk of frost damage ($0 \leq R \leq 1$)
 $F(W_{\text{crit}})$ is the distribution function of the critical water content
 $f(W_{\text{act}})$ is the frequency function of the actually occurring water content
 $W_{\text{saturated}}$ is the water content at total saturation of the concrete

In eqn. (III.11) it is assumed that neither W_{crit} nor W_{act} has a distinct, deterministic value, but that there is a certain variation depending on variations in material and environment.

²⁵ G. Fagerlund: Freeze-thaw resistance of concrete. Destruction mechanisms. Concrete technology. Test methods. Quality control. Div. of Building Materials, Lund Institute of Technology, Report TVBM-3060, 1995.

²⁶ G. Fagerlund: Internal frost attack - State of the art. In (Editors M. Setzer. R. Auberg) "Frost resistance of Concrete". RILEM Workshop in Essen Sept 22-23, 1997. E&F Spon 1997.

²⁷ G. Fagerlund: Service life with regard to frost attack - a probabilistic approach. In "Durability of Building Materials and Components 8", Vancouver May 30-June 3, 1999. E&F Spon, 1999.

Leaching will affect both W_{crit} and W_{act} . The effect can be assumed to be such that the risk of frost damage increases. W_{crit} will be reduced since leaching will cause a coarsening of the pore system, thereby increasing the amount of freezable water. W_{act} will be increased since the concrete will absorb water more readily. Besides, the coarsening of the pore system will increase the diffusivity of dissolved air that emanates from enclosed air-bubbles in air-pores. Therefore, the air-pore system will become more rapidly inactivated due to a gradual water absorption²⁸.

The effect of leaching on the frost resistance can be quantified by determining the values of W_{crit} and W_{act} on cores taken from different parts of the structure, unleached and leached. The technique for such testing is known²⁹. Thereafter, the increased risk of frost damage can be calculated by eqn. (III.11). A method for extrapolation of the future frost deterioration has been suggested³⁰. The extrapolation depends on the "wetness" of the environment. As one extreme, in very moist conditions, destruction is supposed to be linearly growing with time. As the other extreme, in more dry conditions, destruction is supposed to be unchanged, and maintain the same level as at it had at the time of inspection.

The effect of leaching on the risk of internal frost attack is illustrated in Fig. III,7.

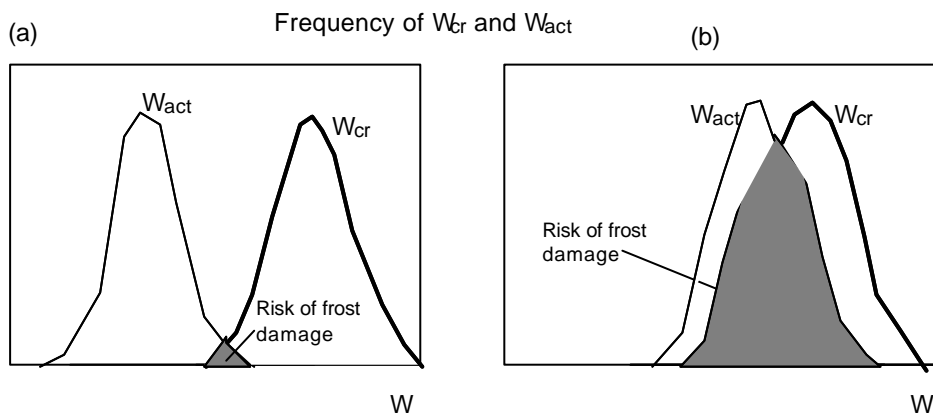

Fig. III.7: Effect of leaching on the risk of frost damage - principles.
(a) Before leaching. (b) After leaching.

²⁸ G. Fagerlund: Predicting the service life of concrete exposed to frost action through a modelling of the water absorption process in the air-pore system. In (Editors H. Jennings, J. Kropp, K. Scrivener), "The Modelling of Microstructure and its Potential for Studying Transport Properties and Durability". Kluwer, 1994.

²⁹ G. Fagerlund "The Critical Degree of Saturation Method for Assessing the Freeze-Thaw Resistance of Concrete", Materials and Structures, Vol 10, No 58, 1977.

³⁰ G. Fagerlund: Frost resistance of concrete. Estimation of the future deterioration. Div. of Building Materials, Lund Institute of Technology, Report TVBM -3067, 1995.

III:4.2 Salt-frost scaling

This type of frost attack causes a gradual erosion of the concrete surface. The erosion rate is mainly determined by the air-pore structure of the concrete. Concrete that has a high scaling resistance when unleached might possibly obtain a reduced scaling resistance after leaching, since the amount of freezable water increases. The relation between leaching and scaling resistance is unknown, however.

The scaling rate can be estimated by a laboratory freeze-thaw experiment in salt solution³¹. On basis of results from this test the future scaling rate in the real environment can be extrapolated³²

³¹ Swedish standardized test method, SS 13 72 44, "Concrete Testing-Hardened Concrete-Frost Resistance".

³² See footnote 30.

III:5 Uplift and overturning of the structure

A concrete dam normally has a water pressure gradient across its volume. The pressure is higher at the upstream face, and lower at the downstream face. This water pressure gives an uplift that must be balanced by other forces, primarily the gravitational force.

The distribution of the uplift forces (overturning forces) depends on the water flux in the dam. When the dam is leached the water flow lines will change causing a redistribution of the uplift forces. This is visualized in Fig. III.8. In order to estimate the risk of instability of the dam the new pressure (uplift force) distribution at the time of inspection has to be determined. In order to estimate the *future risk* of instability the future pressure distribution has to be predicted. This means that, using the traditional technique for analysing the pressure distribution, the future flow lines and equipotential lines in the structure has to be predicted. But, these lines are determined by the degree of leaching in different parts of the structure. This means that a prediction of the future risk of instability requires a prediction of the future leaching.

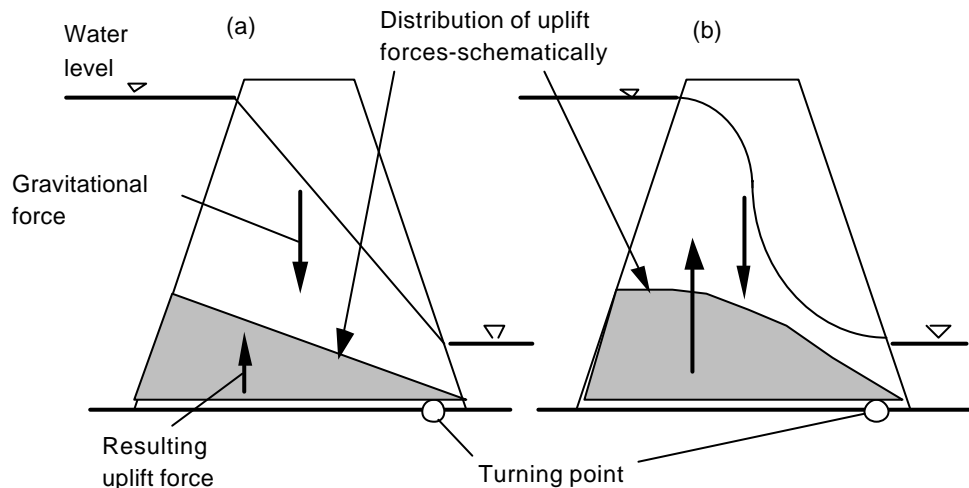

Figure III.8: Changes in the stability of a dam caused by changes in the inner pressure profile due to leaching. (a) Before leaching. (b) After leaching

APPENDIX

Relation between the materials structure and strength

The presentation below is based on previous work by the author^{33, 34}

A:1 The cement paste strength

A volume of a cement paste with its different phases are shown in Fig A.1³⁵.

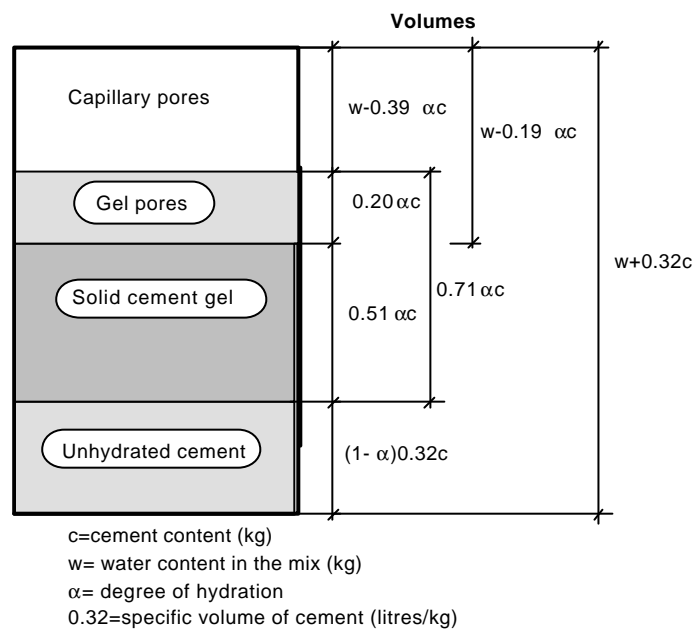

Fig. A.1: Volume distribution of phases in a volume of cement paste.

³³ G.Fagerlund: Relations between porosity and mechanical properties of materials. Div. of Building Technology, Lund Institute of Technology, Report 26, 1972. (In Swedish)

³⁴ G. Fagerlund: Relations between the strength and the degree of hydration or porosity of cement paste, cement mortar and concrete. In (Editor P. Nepper-Christensen) "Seminar on hydration of concrete", Published by Aalborg Portland, Aalborg, Denmark, February 1988.

³⁵ The expressions for different volumes are based on the Powers' investigations. T.C. Powers: Physical properties of cement paste. In "Chemistry of Cement", Proc. 4th Int. Symposium, Washington, 1960. National Bureau of Standards, Monograph 43, Vol II, Washington D.C. 1962.

There are at least two possibilities to estimate the strength of the cement paste:

1: The "gel-space ratio" concept³⁶

$$f_p = f_o' \cdot X^k \quad (\text{A.1})$$

where f_p is the cement paste strength [MPa]
 f_o' is the strength of the cement gel including gel pores [MPa]
 X is the gel-space ratio [-]
 k is an exponent ($2.5 < k < 3$). In the following, $k=3$ is used.

The gel space ratio is defined

$$X = (\text{gel volume}) / (\text{gel volume} + \text{capillary pore volume}) \quad (\text{A.2})$$

or

$$X = 0.71 \cdot \alpha / [0.71 \cdot \alpha + (w/c - 0.39 \cdot \alpha)] = 0.71 \cdot \alpha / (0.32 \cdot \alpha + w/c) \quad (\text{A.2}')$$

Where α is the degree of hydration [-]
 w/c is the water-cement ratio [-]

Inserting eqn. (A.2') in eqn. (A.1) and using $k=3$ gives

$$f_p = f_o' \cdot [0.71 \cdot \alpha / (0.32 \cdot \alpha + w/c)]^3 \quad (\text{A.3})$$

This equation has the big drawback that the strength reaches a maximum for the w/c -ratio 0.39. For lower w/c -ratios than 0.39 hydration cannot be complete due to lack of space for the gel. The maximum hydration corresponds to zero volume of capillary pore, and to $X=1$. This consequence of the gel-space ratio is shown by the following example.

The maximum possible degree of hydration is $\alpha_{\max} = (w/c) / 0.39$.

1: $w/c=0.39$ $\alpha = \alpha_{\max}=1$: $X=1$, $f_p = f_o'$

2: $w/c=0.30$, $\alpha = \alpha_{\max}=0.77$: $X=1$, $f_p = f_o'$

3: $w/c=0.20$, $\alpha = \alpha_{\max}=0.51$: $X=1$. $f_p = f_o'$

The reason behind this defect is that the strength contribution of the unhydrated cement is neglected in the gel-space ratio concept. This problem is avoided by using the "total-porosity" concept described below.

³⁶ T.C. Powers: Physical properties of cement paste. In "Chemistry of Cement", Proc. 4th Int. Symposium, Washington, 1960. National Bureau of Standards, Monograph 43, Vol II, Washington D.C. 1962.

2: The "total-porosity" concept:

The cement paste strength is described by

$$f_p = f_0(1-P)^k \quad (\text{A.4})$$

where f_0 is the strength of the solid (non-porous material in the cement paste [MPa]
 P is the total porosity of the cement paste [-]
 k is an exponent ($2.5 < k < 3$). In the following $k=3$ is used.

$f_0 > f_0'$ since no pores are included in f_0 while gel pores are included in f_0' .

The total porosity is (see Fig. A.1)

$$P = (w/c - 0.19 \cdot \alpha) / (w/c + 0.32) \quad (\text{A.5})$$

Inserting eqn. (A.5) in eqn. (A.4) and using $k=3$ gives

$$f_p = f_0 [1 - (w/c - 0.19 \cdot \alpha) / (w/c + 0.32)]^3 \quad (\text{A.6})$$

or

$$f_p = f_0 [(0.32 + 0.19 \cdot \alpha) / (w/c + 0.32)]^3 \quad (\text{A.6'})$$

This equation predicts increased strength also when the w/c-ratio is lowered below 0.39 which is shown by the following example, which is the same as above.

1: w/c=0.39	$\alpha = \alpha_{\max} = 1$:	P=0.282	$f_p = 0.370 \cdot f_0$
2: w/c=0.30,	$\alpha = \alpha_{\max} = 0.77$:	P=0.248	$f_p = 0.425 \cdot f_0$
3: w/c=0.20,	$\alpha = \alpha_{\max} = 0.51$:	P=0.198	$f_p = 0.516 \cdot f_0$

The two structural parameters for strength, X^3 , and $(1-P)^3$ are compared in Table A.1. The degree of hydration is assumed to be 0.80 for $w/c \geq 0.50$ and 0.65 for $w/c = 0.40$.

Table A.1: Comparison of the parameter X^3 in the gel-space ratio concept and the parameter $(1-P)^3$ in the total porosity concept for calculation of the cement paste strength

w/c	X^3	$(1-P)^3$
0.40	0.437	0.233
0.50	0.424	0.191
0.60	0.292	0.135
0.70	0.210	0.099
0.80	0.150	0.075
0.90	0.119	0.058
1	0.092	0.046

The parameter X^3 is considerably higher, which just reflects that $f_0' < f_0$.

In order to find a relation between f_0' and f_0 the strength calculated by eqn. (A.3) and the strength calculated by eqn. (A.6) are made equal for w/c=0.60. Then, for the degree of hydration 0.80 and w/c=0.60 the following relation is valid

$$f_0' \cdot 0.292 = f_0 \cdot 0.135 \quad (\text{A.7})$$

which gives

$$f_0' = 0.46 \cdot f_0 \quad (\text{A.7'})$$

Thus, the gel strength (including gel pores) is about 45% of the strength of the solid material in cement paste, which seems reasonable considering that the gel porosity is 28%. A material having the porosity 28% should have a strength that is about $(1-0.28)^3 = 37\%$ or $(1-0.28)^{2.5} = 44\%$ of the strength of the solid material. The agreement with the theoretical value 46% is fair considering the very big simplifications made in the theoretical analysis.

A reasonable value of f_0 is 380 MPa³⁷, which by eqn. (A.7') gives $f_0' = 175$ MPa. Then, the strength of cement paste can be calculated by one of the two equations

$$f_p = 175 \cdot [0.71 \cdot a / (0.32 \cdot a + w/c)]^3 \quad (\text{A.3'})$$

$$f_p = 380 \cdot [(0.32 + 0.19 \cdot a) / (w/c + 0.32)]^3 \quad (\text{A.6''})$$

³⁷ G. Fagerlund: Relations between the strength and the degree of hydration or porosity of cement paste, cement mortar and concrete. In (Editor P. Nepper-Christensen) "Seminar on hydration of concrete", Published by Aalborg Portland, Aalborg, Denmark, February 1988.

Strength values calculated by these equations are shown in Table A.2. The degree of hydration is 0.65 for w/c=0.40 and 0.8 for the other w/c-ratios (the same as in Table A.1).

Table A.2: Calculated strength of mature cement paste and empirical strength values for Swedish ready-mix concrete³⁸ (MPa)

w/c	Gel space ratio concept Eqn. (A.3')	Total porosity concept Eqn. (A.6')	Concrete strength *)
0.40	77	89	60
0.50	74	72	51
0.60	51	51	43
0.70	37	38	36
0.80	27	28	31
0.90	21	22	26
1	16	18	22

*) Average for Swedish ready-mix concrete.

Thus, the two ways of expressing the strength of cement paste give almost the same result. There is a certain deviation for the lowest w/c-ratio, where the gel-space ratio gives a lower value. But, this can be explained by the fact that the gel-space ratio neglects the strength of unhydrated cement. Therefore, for low degrees of hydration (65% for w/c=0.40) the gel-space ratio underestimates the real strength.

A:2 Concrete strength

Since aggregate normally is the strongest part of a concrete one might as a first approximation use the "weakest link" concept, and assume that the concrete strength is equal to the strength of the cement paste

$$f_c = f_p \quad (A.8)$$

where f_c is the concrete strength [MPa]

The following mean curve (Abram's formula) is valid for Swedish ready-mix concrete³⁹

$$f_c = 118 / 5.4^{w/c} \quad (A.9)$$

³⁸ G. Ysberg: Relation between the water-cement ratio/water-air-cement ratio and compressive strength. Swedish Cement and Concrete Research Institute, Report Ra 3:79, 1979.

³⁹ G. Ysberg: Relation between the water-cement ratio/water-air-cement ratio and compressive strength. Swedish Cement and Concrete Research Institute, Report Ra 3:79, 1979.

Strength values calculated by this equation are shown in Table A.2. The concrete strength is somewhat lower than the cement paste strength for lower w/c-ratios, and somewhat higher for higher w/c-ratios. For w/c=0.70 the cement paste strength and the concrete strength are equal.

The reason for the fairly small deviation from the weakest link hypothesis probably is that crack arrest caused by aggregate, and stress concentrations due to different E-modulus of aggregate and cement paste are neglected⁴⁰. The crack arrest effect increases when the amount of aggregate increases, which it does when the w/c-ratio is increased. The stress concentration effect is certainly not higher at low w/c-ratios, so that could not be the explanation to the lower concrete strength values. On the other hand, the crack arrest effect is less effective for low w/c-ratios due to the lower amount of aggregate. This effect might be dominating for low w/c-ratios.

An almost perfect correlation between the cement paste strength and the concrete strength is obtained by the following empirical equation based on the data in Table A.2 using the total-porosity concept for cement paste strength.

$$f_c \approx 15 + 0.5 \cdot f_p \quad (\text{for } f_c > 25 \text{ MPa}) \quad (\text{A.10})$$

Eqn. (A.10) is only empirical, however, and is only based on mean strength values for mature Swedish ready-mix concrete produced with Swedish aggregate and Swedish cement. It is quite clear that the coefficients 15 and 0.5 are different for different concrete constituents. It is also questionable if eqn. (A.10) can be used for estimating the effect on concrete strength of a reduction in the cement paste strength. The calculated effect using eqn. (A.10) will probably be smaller than the real strength loss in the concrete.

Therefore, for practical purpose one can just as well use eqn. (A.8). This means that a certain relative change in strength of the concrete is the same as the relative change in strength of the cement paste.

$$\Delta f_c / f_c = \Delta f_p / f_p \quad (\text{A.11})$$

where Δf_c is the reduction in the concrete strength [MPa]
 Δf_p is the reduction in the cement paste strength [MPa]
 f_c is the concrete strength before reduction [MPa]
 f_p is the cement paste strength before reduction [MPa]

This relation was used above in estimating the effect of leaching on strength; eqn. (II.34).

⁴⁰ G.Fagerlund: Relations between porosity and mechanical properties of materials. Div. of Building Technology, Lund Institute of Technology, Report 26, 1972. (In Swedish)