



LUND UNIVERSITY

Calorimetric methods for the study of fungi on building materials

Li, Yujing

2004

[Link to publication](#)

Citation for published version (APA):

Li, Y. (2004). *Calorimetric methods for the study of fungi on building materials*. [Licentiate Thesis, Division of Building Materials]. Division of Building Materials, LTH, Lund University.

Total number of authors:

1

General rights

Unless other specific re-use rights are stated the following general rights apply:

Copyright and moral rights for the publications made accessible in the public portal are retained by the authors and/or other copyright owners and it is a condition of accessing publications that users recognise and abide by the legal requirements associated with these rights.

- Users may download and print one copy of any publication from the public portal for the purpose of private study or research.
- You may not further distribute the material or use it for any profit-making activity or commercial gain
- You may freely distribute the URL identifying the publication in the public portal

Read more about Creative commons licenses: <https://creativecommons.org/licenses/>

Take down policy

If you believe that this document breaches copyright please contact us providing details, and we will remove access to the work immediately and investigate your claim.

LUND UNIVERSITY

PO Box 117
221 00 Lund
+46 46-222 00 00

Calorimetric methods for the study of fungi on building materials

Yujing Li



LUND INSTITUTE OF TECHNOLOGY
LUND UNIVERSITY

Division of Building Materials

Calorimetric methods for the study of fungi on building materials

Yujing Li

TVBM-3121

Licentiate thesis

ISRN LUTVDG/TVBM--04/3121--SE(1-79)
ISSN 0348-7911 TVBM

Lund Institute of Technology
Division of Building Materials
Box 118
SE-221 00 Lund, Sweden

Telephone: 46-46-2227415
Telefax: 46-46-2224427
www.byggnadsmaterial.lth.se

For my grandma.

献给我的外祖母

Preface

This project is funded by FORMAS (The Swedish Research Council for Environment, Agriculture Sciences and Spatial Planning).

It would not have been possible for me to come this far by myself. I wouldn't have had enough courage to apply for the position and start the project without Zhiming's encouragement. My family has supported me emotionally and mentally during the past two and half years.

I want to thank my supervisor, Lars Wadsö, for inspiration and great help! I have really learned a lot from you! I also thank my co-supervisor, Jonny Bjurman, for advice, especially on the mycology part. Thanks to all the colleagues in BML for kindness and help, especially thank Stefan and Bengt for technical support and laboratory assistance; and Sanne for discussions and comments.

There are many other names I would like to mention. Stephen: thanks for being upstairs and helping me with my building physics knowledge. Yoke-Chin: thanks for sharing my difficult time and frustrations. Frederic: thanks for being there, offering a hand when I need... And all the friends who came and the friends who have left...

For all the friendship, love and care, I feel really grateful. It has been better and easier with all of you!

李宇璟

Yujing Li

December 15, 2004

Lund

Abstract

Fungi grow in buildings when the environmental factors are favourable. Mould fungi can produce toxic substances and have different emissions that are believed to have negative health impact on the building occupants. The growth of rot fungi can threaten the integrity of critical structure components made of wood in buildings.

The factors that are most critical for fungal growth in buildings are nutrients, moisture and temperature. Many building materials are organic and they can be utilised as nutrient sources for fungi. The temperature in the buildings is normally at the level that suits most fungi to grow. Moisture is the key factor for fungal growth in buildings but moisture impact on fungal growth is also influenced by other factors, such as temperature. One important factor for indoor mould growth is low temperature on indoor surface.

The aim of this project is to study the fungal growth habits on building materials as a function of humidity, temperature and other environmental parameters. The method of calorimetry is used as a way to quantify fungal activity on building materials. Calorimetry is a general, but sensitive method that can continuously monitor biological processes as a function of environmental conditions. In this report, three different studies are presented: 1. A calorespirometric device was developed and used to study the energetics and gas exchange of one rot fungus and two mould fungi. 2. Calorimetry was correlated with the quantification of ergosterol, an established method in fungal research. It is shown that there is correlation between these two methods. 3. Calorimetry combined with equipment for humidity and temperature modification makes it possible to measure fungal activity at different temperature and humidity levels.

Isothermal calorimetry has proved to be a good method to study fungal activity and will be used in the continuation of this project for the study of fungal growth on building materials.

Key words

Fungi, building materials, mould, rot fungi, *Serpula lacrymans*, fungal growth, fungal activity, ergosterol, humidity, temperature, oxygen, isothermal calorimetry, microcalorimetry, calorespirometry

Table of Content

1.0	INTRODUCTION.....	1
1.1	MOULDS IN BUILDINGS	1
1.2	ROT FUNGI IN BUILDINGS	2
1.3	PURPOSE OF THE PROJECT	2
1.4	LIMITATIONS.....	3
1.5	FINAL AIM OF PROJECT.....	3
2.0	FUNGI.....	5
2.1	MOULDS	5
2.1.1	<i>Indoor mould fungi and health</i>	6
2.1.2	<i>Common indoor mould</i>	7
2.2	WOOD DECAY FUNGI - ROT FUNGI	9
2.2.1	<i>Serpula lacrymans</i>	10
2.3	FACTORS FOR FUNGAL GROWTH.....	10
2.3.1	<i>Substrate – nutrients</i>	11
2.3.2	<i>Water – moisture</i>	12
2.3.3	<i>Temperature</i>	12
2.3.4	<i>Interaction between temperature and humidity</i>	13
2.3.5	<i>Oxygen and carbon dioxide</i>	13
2.4	METHODS FOR FUNGAL GROWTH ASSESSMENT	13
2.4.1	<i>Biomass - Direct measurements</i>	14
2.4.2	<i>Fungal constituents</i>	15
2.4.3	<i>Fungal activity</i>	16
2.4.4	<i>Other methods</i>	16
2.4.5	<i>Comparison of different methods</i>	16
3.0	FUNGI IN BUILDINGS.....	19
3.1	THE BUILDING.....	19
3.2	BUILDING MATERIALS.....	19
3.2.1	<i>Wood</i>	20
3.2.2	<i>Gypsum board</i>	22
3.2.3	<i>Wall surface material: wallpaper and paint</i>	23
3.2.4	<i>Concrete</i>	23
3.2.5	<i>Other materials</i>	24
3.3	BUILDING PHYSICS	24
3.3.1	<i>Heat</i>	24
3.3.2	<i>Moisture</i>	26
3.4	LIMITING FACTORS FOR FUNGAL GROWTH IN BUILDINGS	32
3.5	MODELLING MOULD GROWTH IN BUILDINGS.....	33
3.5.1	<i>Previous measurements and modelling of mould growth</i>	34
3.5.2	<i>Modelling mould activity</i>	37
4.0	BIOLOGICAL CALORIMETRY	41
4.1	ENERGY – HEAT – LIFE.....	41
4.2	ISOTHERMAL CALORIMETRY	42
4.3	BIOLOGICAL CALORIMETRY	43

4.4	CALORESPIROMETRY	44
5.0	CALORIMETRIC STUDIES IN THIS WORK.....	47
5.1	CALORESPIROMETRIC METHOD	47
5.1.1	<i>Calorespirometric measurement on Serpula lacrymans.....</i>	<i>49</i>
5.1.2	<i>Calorespirometric measurement on two mould fungi (Paper I).....</i>	<i>54</i>
5.2	CORRELATING CALORIMETRY AND ERGOSTEROL QUANTIFICATION (PAPER II)	54
5.2.1	<i>Method.....</i>	<i>54</i>
5.2.2	<i>Results.....</i>	<i>54</i>
5.3	CALORIMETRIC MEASUREMENT OF FUNGI ON REAL SUBSTRATE.....	59
5.3.1	<i>Relative humidity modifier.....</i>	<i>60</i>
5.3.2	<i>Temperature modification.....</i>	<i>61</i>
5.3.3	<i>Measurements and Results.....</i>	<i>62</i>
6.0	CONCLUSION	67
7.0	FUTURE WORK.....	69
	BIBLIOGRAPHY	71
	COLLECTION OF PAPERS	79

1.0 Introduction

The main aim of this work is to develop methods based on calorimetry for studies of fungal activity on building materials. The interest in fungi on building materials originates from the problems we have with mould and rot fungi in our buildings.

Moulds easily grow on buildings materials when they are humid. During the last 30 years there has been an increased interest in mould in buildings in Sweden and other countries, mainly because of the increasing awareness that indoor air quality is related to health, and the increasing concern for the possible relations between indoor mould and health (McNeel and Kreutzer 1996).

Rot fungi degrade wood in buildings and can cause large damage and structural failure in both historical and modern buildings.

In this introductory chapter, a short background to the subject of this thesis is given.

1.1 Moulds in buildings

With lower levels of outdoor air pollution in developed countries, more attention has been paid to the indoor environment, in which people normally spend more than 90% of their time (Sarwar et al. 2003). Modern houses provide people with protection from the external environment, for example, by giving thermal comfort by cooling and heating systems. At the same time, the indoor environment is also a relatively closed environment that is quite different from the outdoor environment. For example, the indoor air quality (IAQ) is largely influenced by emissions from the building itself and from people's indoor activities. There have been many cases of people complaining about not feeling well, or even feeling sick after spending time inside of certain buildings. This is sometimes called the sick building syndrome (SBS) and is generally believed to be caused by bad IAQ (Lunau 1992; Jones 1999). The existence of high concentrations of indoor pollutants, some of which possibly have microbiological origin, leads to lower IAQ and increases the occurrence of SBS (Cooley et al. 1998).

IAQ is influenced by pollutants from many different sources. The chemical contaminants, for example, volatile organic compounds (VOC), are emitted from building materials, furniture, adhesives, textiles, electronic devices etc (Jones 1999; Meininghaus et al. 2000). VOC also come from biological sources like humans, animals, microorganisms and plants in the building (Wolkoff and Nielsen 2001). The accumulation of carbon dioxide (CO₂) exhaled by the occupants is also an important pollutant (although it is known not to influence health except at extremely high concentrations) (Appleby 1992). However, the focus of attention in the IAQ field has in the last years moved from problems of VOC etc. to other subjects. One of the most important of these is microbiological indoor contamination; a group that includes mould and bacteria (and possibly other types of organisms), and substances produced by them. At least half of the air quality cases presently investigated by the National Institute for Occupational Safety and Healthy in the United States concern microbial

contamination. Among the microorganisms in buildings, moulds are considered to be the most interesting in relation to IAQ (King and Auger 2002).

Mould problems in buildings are common in tropical and subtropical countries where the climate is warm and humid all year round. However, such problems are also significant in countries with temperate climate, such as Sweden, England, Canada, the US and other countries where there has been an intense discussion about indoor fungal contamination in recent decades (Nevalainen et al. 1991; Jones 1999; Norbäck et al. 2000; Wolkoff and Nielsen 2001; King and Auger 2002).

Although the direct relation between mould growth in buildings and health in many ways is difficult to investigate and there are conflicting evidence published, it is generally accepted that the existence of mould in the buildings is unpleasant, and it can trigger a series of health problems, such as SBS, allergies etc. (Cooley et al. 1998), which will be discussed in chapter 2.

1.2 Rot fungi in buildings

Although the main emphasis of this work is on mould fungi, the calorimetric techniques we are using are quite general and can also be used for rot fungi (and many other types of biological samples). Some studies have therefore also been conducted with the dry rot fungus *Serpula lacrymans*.

Although the discussion on rot fungi in buildings is not at all as active as the discussion on moulds, rot fungi are also important as they can cause large constructional damage in wood constructions (Bech-Andersen 1995). *Serpula lacrymans* is the most important timber decay fungus in buildings in Northern and Central Europe and in Japan and Australia. Detecting and removal of rot fungi in buildings can cause loss and damage to the building and consequently maybe be very expensive (Singh 1999).

1.3 Purpose of the project

The focus of this licentiate thesis is on the knowledge and background of the problem with fungi in buildings, and on development of experimental methods. More measurements and modelling will be carried out in the second part of the project, after the licentiate.

The purpose of this doctoral project is to:

- Exploit isothermal calorimetry as a, hopefully efficient, method of quantifying fungal activity.
- Measure fungal activity on building materials under different environmental conditions.
- Use the results of the measurements to model fungal growth in buildings as a function of humidity and temperature.

1.4 Limitations

Limitations of this work are:

- This project is a study of laboratory methods and building construction design tools. Methods are not designed for detecting fungal problems in buildings.
- No health effects of fungi are studied in this project.
- Only a few common indoor fungal species will be studied in this project. However, they should also represent other fungal species.
- When we discuss buildings we mainly do this from a Swedish perspective (although fungal problems in buildings are worldwide).

1.5 Final aim of project

The aim of the doctoral research project is to build a model for fungal growth as function of temperature, humidity, oxygen, carbon dioxide concentrations and other environmental parameters on various building materials with calorimetric methods. Hopefully this will contribute to better building design and maintenance, and also to healthier buildings.

2.0 Fungi

Fungi are different from plants, which have chlorophyll and have capability of photosynthesis, and also different from animals, which have internal digestive systems and survive by up-taking and ingesting other organisms as food sources (Carlile et al. 2001; Deacon 2001). Fungi are distinguished as an independent kingdom: the fifth kingdom. The science of fungi is called mycology. Fungi are heterotrophs, survive by degrading other organisms and organic compounds to simple components as nutrition for their own use, by means of excreting enzymes to their surrounding environment. Fungi clear away animal and plant debris and play an important role in the biological world as cleaners and enabling recycling of materials. Fungi exist everywhere and most often reproduce by spores¹.

Many fungal functions are beneficial for human beings, such as the bio-degradation of waste and its recycling role. Some fungi can also be used as food and enzymes extracted from fungi can be used in many industries, such as food fermentation, detergent catalyst etc. Organic compounds, such as penicillin and other antibiotic compounds produced by fungi can be used as medicine (Carlile et al. 2001). However, the degrading capability of fungi on building materials is not welcome and some of the fungi existing in the house are also suspected of not being good for human health (Gravesen et al. 1994).

Indoor mould fungi and rot fungi are the two main groups of fungi found in buildings.

2.1 Moulds

Mould (also spelled “mold”), refers to a conspicuous mass of mycelium (masses of vegetative filaments, or hyphae) and fruiting structures produced by various fungi that appears on the surface of materials. Moulds are also called microfungi, as they do not have large fruit bodies (mushrooms) that macrofungi have (Gravesen et al. 1994).

Mould can be found on plants, soil, animal debris and almost everywhere in the outdoor environment. There is a similarity and connection between the common moulds found outdoors and indoors, as mould spores can be transported from outdoor to indoor (and vice versa) by air. However, there are also differences between outdoor and indoor moulds because different moulds have different adaptation to indoor and outdoor environments, e.g., temperature, humidity and material properties (Miller 1992).

When growing indoors, mould can be found on the surface of organic materials, such as foodstuffs, textiles, building materials etc. They can also grow on particles containing organic compounds, for example on house dust. By excreting enzymes, mould can decompose organic compounds, such as cellulose in wallpaper, and therefore deteriorate such materials. However, they mainly live on low molecular mass substances and deteriorate materials mainly by fouling them. Microbial volatile

¹ Most of the mould fungi reproduce by conidia, asexual spores. In this thesis, ‘spore’ is used as a general term for both spores and conidia.

organic compounds (MVOC) and mycotoxins are produced by moulds (Carlile et al. 2001).

Moulds spores can resist harsh environment, such as dryness and low temperature, and wait to germinate and grow until the environment is suitable (Carlile et al. 2001).

2.1.1 Indoor mould fungi and health

It is generally known that indoor mould can influence human health, because the components and products by mould that might be negative to human health.

Spores

Mould produces large quantities of spores. For example, a colony arising from a single spore of *Penicillium* can produce as many as 10^{12} spores in a few days (Miller 1992). Most fungal spores are very small, range normally 2-20 μm , and are air borne (Deacon 2001). Spore concentration in the air can be high in a mould damaged building. Spores in the air can be inhaled to respiratory pathways. Every mould spore is a potential allergen due to its protein content. Inhalation of very large amount of spores, usually in occupational settings and not in homes or offices, can cause allergy and hypersensitivity pneumonitis (a syndrome caused by inhalation of high concentration of dusts containing organic matter including fungal spores) (Nicholls 1992).

The surveyed fungal spore concentrations in indoor air vary from hundreds colony forming units (CFU) per m^3 to thousands CFU/ m^3 (Jones 1999). Quantitative standards/guidelines for acceptable total spore concentration in indoor air range from less than 100 CFU/ m^3 to greater than 1000 CFU/ m^3 as the upper limit for non-contaminated indoor environments (Miller 1992; Rao et al. 1996).

Mycotoxin

Mycotoxins are toxic secondary metabolites produced by fungi, usually mould. They are produced to compete for nutrients with rival species (Carlile et al. 2001). Although a few mycotoxins in proper concentration have been found to be beneficial for human beings, such as penicillin, there are also strong toxic mycotoxins. The most well known example is aflatoxin, produced by *Aspergillus flavus* that is believed to be one of the most potent known natural carcinogens (Deacon 2001). Aflatoxin can be found in high concentration on spores of *A. flavus* and *A. parasiticus* grown on nuts and grain. There are other mycotoxin producers, such as *Penicillium citrium*, *P. cyclopium*, *P. rubrum* and all *Fusarium* spp (Deacon 2001). *Stachybotrys chartarum* is the most discussed mycotoxin producing fungus found in buildings (Andersson et al. 1997), but there is still lacking evidence that its toxins generally cause health problems in buildings.

VOC

Fungi can also produce volatile organic compounds, so called microbial VOC (MVOC) (Bjurman 1999) that can give an unpleasant smell in mouldy buildings. Over 500 volatile organic compounds have been described from fungi of various

kinds. Ethanol is the dominant VOC of moulds on certain substrates (Miller 1992). As many of the MVOC have strong odours, inhalation of such compounds can disturb occupants of a building (Wolkoff and Nielsen 2001).

Pathogenic fungi

There are a number of fungi that are pathogenic. For example, *Aspergillus fumigatus*, *A. terreus* and *A. flavus* can cause aspergillosis, an invasive lung disease (Miller 1992). As the pathogenic fungi have temperature optimums close to the temperature of the human body, they are not particularly well suited to growth in buildings in temperate climate.

2.1.2 Common indoor mould

Common mould species detected indoors and some locations where they are commonly found are listed in Table 1.

Table 1: Common indoor mould species (Grant et al. 1989; Nielsen 2001; Johansson 2004)

Mould species	Common indoor habitat
<i>Alternaria alternate</i>	Wallpaper, gypsum board, bathroom
<i>A. tenuissima</i>	Wallpaper, gypsum board
<i>Aspergillus versicolor</i>	Water damaged materials
<i>A. niger</i>	Air, wood, dust
<i>A. sydowii</i>	Most materials
<i>A. ustus</i>	
<i>Aureobasidium pullulans</i>	Paint, bathrooms, window frames
<i>Chaetomium spp.</i>	Wood, cellulose-containing materials, water damaged area
<i>Cladosporium sphaerospermum</i>	Paints, wood, wall papers, caulking, especially in bathrooms
<i>C. herbarum</i>	Paints, wood, wall papers, caulking, air, dust
<i>C. cladosporioides</i>	
<i>Eurotium repens</i>	House dust
<i>Fusarium moniliforme</i>	
<i>Geomyces pannorum</i>	
<i>Mucor spp.</i>	Dust
<i>Penicillium brevicompactum</i>	Wooden materials
<i>P. chrysogenum</i>	All materials, air, dust
<i>P. corylophilum</i>	Most materials
<i>P. nigricans</i>	
<i>P. palitans</i>	Most materials
<i>P. expansum</i>	Wood
<i>P. polonicum</i>	
<i>P. spinulosum</i>	
<i>Rhizopus spp.</i>	dust
<i>Phoma spp.</i>	Paints, wood, wall papers, caulking, bathroom
<i>Rhodulotorula rubra</i>	Paints, wood
<i>Stachybotrys chartarum</i>	Gypsum board, water damage area
<i>Tricoderma spp.</i>	Wood
<i>Ulocladium chartarum</i>	Wood, wall paper, gypsum board
<i>U. consortiale</i>	

Moulds grow on substrate with high water activity (a_w). According to Grant and co-workers (Grant et al. 1989), mould species can be categorised into three groups according to their minimum water activity requirement (a_{w-min}) for growth:

Primary colonisers:	$a_{w-min} < 0.8$
Secondary colonisers:	$0.8 < a_{w-min} < 0.9$
Tertiary colonisers:	$a_{w-min} > 0.9$

Primary colonisers

Moulds included in this group do not demand high humidity for growth. They can also be called xerophilic moulds (prefer dry conditions) as they can grow at drier environment than the other two groups. The primary colonisers include species belonging to the genera *Penicillium*, *Aspergillus*, *Eurotium*, *Walleimia*, etc. (Grant et al. 1989). They can grow on most materials in buildings. Some of species are briefly described here.

Penicillium

The genus *Penicillium* is a large group with many species present in indoor environments. They grow relatively fast, appear green or sometimes white, grey or bluish, and can produce large amount of spores.

The growth of some *Penicillium* species can destroy building materials. For example, *P. chrysogenum* can destroy wallpaper. They can also produce unpleasant mouldy smell, e.g., *P. polonicum*. Many *Penicillium* species can produce mycotoxins that might trigger allergy, respiratory disease and other unknown health problems (Miller 1992; Gravesen et al. 1994; Samson et al. 2000).

Aspergillus

There are many *Aspergillus* species that have been found inside buildings. They can also grow relatively rapidly. They look white, yellow, yellow-brown, brown to black or have shades of green and blue on the surface and can produce large amount of spores. *Aspergillus* species are common contaminants of food and other different substrates. Some species have optimum temperature growth at 30-40°C. Therefore their occurrence is more common than *Penicillium* in subtropical and tropical regions (Gravesen et al. 1994; Samson et al. 2000).

Some of the *Aspergillus* species, e.g., *A. versicolor* are responsible for material degradation, such as wallpaper. Some species influence human health. For example, *A. niger* spores can infect the human ear and be the cause of airway allergy (Gravesen et al. 1994). Some of the secondary metabolites produced by *Aspergillus* species can be toxic for human beings (Gravesen et al. 1994).

Secondary colonisers

Moulds in this group demand a higher humidity, about 80-90%, than the primary colonisers to start growth. They normally appear in places, such as bathrooms, kitchens and laundry rooms, where water vapour is generated or even condenses.

Common species in this group include *Cladosporium*, *Alternaria*, *Phoma* and *Ulocladium* (Grant et al. 1989).

Cladosporium

Cladosporium species are common in both the outdoor and the indoor environment. Colonies look brown due to abundant pigmented spores. Their dry spores easily become air-borne and can be transported over long distances. *Cladosporium* spores normally can be detected in indoor environment. It is often found, e.g., in bathrooms and humid window frames (Gravesen et al. 1994).

Paints and textiles stored in humid conditions can be discoloured by *Cladosporium*. Due to heavy sporulation, and their spores are easily airborne, *C. herbarum* is the most important fungal allergen, and can cause asthma (Gravesen et al. 1994).

Alternaria

Alternaria species have black surface. When growing in buildings, they can be found on damp spots, such as window frames with condensation and on humid wall or ceilings. Spores can be found in air and in house dust (Gravesen et al. 1994).

Alternaria spores exist abundantly in mouldy houses and can be one of the most important fungal allergen sources. Allergy to *Alternaria* can cause acute asthma (Gravesen et al. 1994).

Tertiary colonisers

The mould species in this group grow on substrates that normally have very high water content, e.g., where there is direct uptake of liquid water from leakage or condensation (Grant et al. 1989; Gravesen et al. 1994; Nielsen 2001). The species in this group include *Stachybotrys*, *Chaetomium*, *Trichoderma*, and *Aureobasidium*.

Stachybotrys

Stachybotrys grow on wet substrates, such as water damaged paper and heavily wetted gypsum board used for interior walls and ceilings (Pasanen et al. 1992; Tuomi et al. 2000; Andersen et al. 2003). Houses that have been flooded or have had fires are often attacked by *Stachybotrys* (large amounts of water are usually used for turning out fires). Within the indoor air research field, this mould has drawn much research due to its toxic secondary metabolites satratoxin G and H.

2.2 Wood decay fungi - Rot fungi

There are several kinds of wood decay fungi found in buildings (Jennings and Bravery 1991). Brown rot and white rot are predominantly basidiomycetes and soft rot fungi are often due to attack by mould fungi, such as *Chaetomium*, *Fusarium* and *Paecilomyces* (Carlile et al. 2001). The most serious brown rot fungus is the dry rot fungus *Serpula lacrymans*, the only rot fungus to be studied in this project. It has drawn much research attention not only because of its ability to attack timber, but also because it can spread through a building across non-nutritional surfaces.

2.2.1 *Serpula lacrymans*

Serpula lacrymans develops fan-shaped cottony growth, patches of aerial mycelia, on substrate surfaces. A number of hyphae grow together forming bundles (strands) that radiates perpendicularly away from substrate, look silky white to yellowish, grey lilac or rusty brown. The strands that have vessel hyphae and wall hyphae extend over surfaces in all directions. The reported maximum length as well as its colour and morphology differ. According to Nuss and co-workers, single strands can be up to 1 cm wide and reach a length of 4 m (Nuss et al. 1991). Pegler gives the mycelia strand diameter as 0.5-2.5 cm and the maximum length as 2 m (Pegler 1991). The strands are distance transporting system for *S. lacrymans* when growing over non-nutritional surfaces. When a fruit-body is formed, its basidiome is mostly effused, forming indefinite and irregular, imbricate pilei. It is 2-10mm thick, and could be 3-10 cm wide, effuso-reflexed, surface greyish to brownish, usually compressed, grayish, silvery, purplish or forming a dark brown cortex (Pegler 1991). The dry rot fungus has the smell of mushrooms.

Serpula lacrymans normally attack soft wood timber. The hyphae of the dry rot attack wood from the surface where the hyphae invade the timber via pith rays and go from there through the pits of the wood walls as well as through holes made by themselves then entering neighbouring cells (Nuss et al. 1991). By producing oxalic acid and systems generating aggressive free radicals, the hemicellulose and cellulose part of the wood are broken down to water soluble sugars, which are absorbed by the fungus. Finally 90-95% of the hemicellulose and the cellulose are broken down by the fungus and large cracks are formed in the wood (Bech-Andersen 1995). The cell walls of the wood can be reduced to a quarter of their former thickness. A brown lignin humus is left over as for other brown rot fungi (Carlile et al. 2001).

2.3 Factors for fungal growth

Fungal spores exist everywhere and it is impossible to eradicate completely. Therefore an understanding of when and how the fungi will grow with different environmental parameters is essential to limit or prevent fungal growth in buildings. Fungal growth needs nutrients, water and a suitable temperature. Most of the fungi are aerobic. Therefore, oxygen (O₂) is also an important factor (Fig. 1). A general description of factors for mould growth is given below:

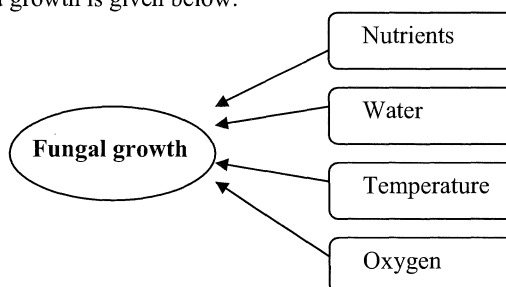

Figure 1: Main factors influencing fungal growth

2.3.1 Substrate – nutrients

Mould fungi

Carbon sources are most essential nutrient for fungal growth. Mould can utilise simple sugars, such as glucose, and also starch, cellulose, organic acids, alcohols, lipids, amino acids and proteins by producing enzymes and degrading complex molecules to simpler structures (Carlile et al. 2001). Such simple organic molecules are then absorbed and degraded (mainly to CO₂ and water) to yield energy for fungi's metabolism and building blocks for its growth. Some soft-rot fungi that sometimes are referred to as moulds, notably *Chaetomium*, can also degrade lignin to some extent. However, moulds have much weaker enzyme systems than rot fungi and they can usually not degrade wood cellulose that is protected by lignin.

Mould growth also needs nitrogen sources, since fungi are not able to fix molecular nitrogen. Most fungi can use inorganic nitrogen as nitrate or ammonia in addition to utilising a wide range of organic compounds (Carlile et al. 2001). The nitrogen is the most essential of the other nutrients as it is an essential part of amino acids, peptides and proteins.

The usual ratio of carbon and nitrogen optimal for fungal growth is about 30:1 (Carlile et al. 2001). Mould also needs other elements, such as sulphur, phosphorus, magnesium, potassium, and trace elements as all other organisms.

Normally the soluble organic compounds that exist in any organic building material surface and house dust are enough for mould growth. Therefore, in the indoor environment, nutrient is normally not the limiting factor for mould growth but it will influence the maximum amount of biomass produced.

Many studies of the influence of environmental factors on mould growth have been made with nutritious artificial substrate like: agar plates. This may not reflect mould growth pattern on 'real' substrates in a building. There is lack of research on how the mould growth on building materials is influenced by environmental factors.

Rot fungi

Serpula lacrymans needs carbon-, nitrogen- and other nutrient sources as other fungi. It can obtain carbon and nitrogen from the wood it is degrading. However, the wood is low in nitrogen content (the C:N ratio of wood is about 500:1) (Carlile et al. 2001). *Serpula lacrymans* has to obtain extra nitrogen sources besides of taking up from substrate by recycling and transporting nitrogen to its growing tips.

Calcium is believed to be necessary for growth of *S. lacrymans*. It is used to neutralize the oxalic acid produced by the fungus; otherwise the fungus will be inhibited by this acid. The sources of calcium for dry rot growth may come from building materials, such as: mortar, concrete, rock-wool, glass-wool, gipsonite, porous concrete and Leca (Bech-Andersen 1995). The optimum pH level for its growth is not well known. However, it is known that *S. lacrymans* can readily acidify its media (Jennings 1991).

2.3.2 Water – moisture

Mould fungi

Mould growth requires humid environment. The higher the humidity up to a certain value, the more mould growth occurs (Ayerst 1969), both when counted as diversity and biomass, given the other environmental conditions are constant, as outlined in Fig. 2.

As discussed earlier, the mould species can be categorized into three groups according to their water demand for growth. The relationship between total mould growth and water activity can be shown as in Fig. 3. The total number of possible mould species and amount of mould biomass increase when the humidity is higher.

Rot fungi

Rot fungi needs higher moisture content than moulds to grow. Typically, they grow where water has condensed or where there has been a water leakage, i.e., at close to water activity 1.0. Optimum moisture content in timber for its growth is about 30-40% (Jennings 1991; Singh 1999). Even the so called dry rot fungus *S. lacrymans* needs moist conditions. However when established, the fungus has the ability to grow over non-nutritional and dry surface due to its special aerial mycelia. This strand structure can transport water several meters from one end to the growth point.

2.3.3 Temperature

Mould fungi

Mould fungi can grow in a relative large temperature range: 0-40°C. Most of the moulds grow best in relatively warm environment, around 20-25°C. Below and above the optimum temperature, the mould growth rate is lower (Grant et al. 1989), as outlined in Fig. 4.

Rot fungi

The general temperature range for mycelial growth of *S. lacrymans* is between -2–28°C. The optimum temperature for the growth is 20–25°C (Hegarty 1991; Jennings 1991). The growth of *S. lacrymans* is more sensitive to high temperatures than most of other rot fungi. Previous research shows that the growth will be halted at 28°C. The lethal temperature is about 35–37.5°C (Hegarty 1991; Jennings 1991; Bech-Andersen 1995).

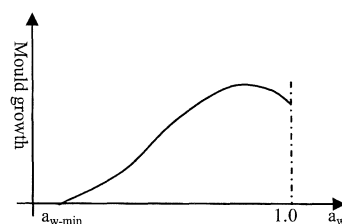

Figure 2: Schematic relationship of mould growth and water activity

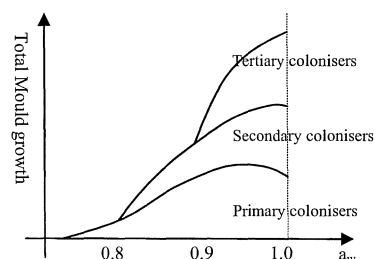

Figure 3: Schematic relationship of total mould fungi growth and water activity

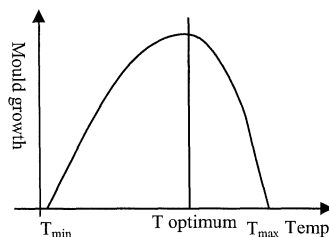

Figure 4: Schematic relationship between mould growth and temperature

2.3.4 Interaction between temperature and humidity

As has been shown by several studies, there is consistent interaction between temperature and humidity on influencing the mould growth, provided all the other conditions are constant (Ayerst 1969; Magan and Lacey 1984; Viitanen 1996; Sedlbauer 2002). Close to the optimum temperature, mould is able to grow in a lower water activity environment. The farther away from optimum temperature, the moisture demands for mould growth are higher.

Spores can endure and survive in a larger range of temperature and humidity environment than fungal colony.

2.3.5 Oxygen and carbon dioxide

Mould fungi

Most of the moulds need oxygen as they are aerobic organisms. That is also the reason that why most of the mould growth appears on the surface of building materials. It has been shown that within the O₂ concentration range of 0-21% of air composition, most of the mould species have higher growth speed when O₂ concentration is higher (Magan and Lacey 1984).

Carbon dioxide can limit the mould growth when in higher concentration (Northolt and Bullerman 1982). High humidity can occur in building cavities, where the air can not be ventilated very well and it is often the location of cold bridges. Carbon dioxide concentration is also normally higher in such locations. Therefore, it is interesting to know whether the accumulation of CO₂ will limit the mould growth. Previous research showed that most of the mould growth could be inhibited when CO₂ concentration increase within the range of 0-15% of air composition. However, the impact of CO₂ on mould fungal growth is also influenced by temperature (Magan and Lacey 1984).

Rot fungi

When O₂ pressure in the air is higher than 5% of total volume, O₂ pressure has little effect on fungal linear growth and when O₂ pressures are at 1.3% (volume), the growth may be retarded moderately (Scheffer 1986). Previous research also shows that *S. lacrymans* can grow as well at reduced O₂ pressure as in normal air but cannot tolerate anaerobic conditions for more than 2 days (Jennings 1991).

High concentration of CO₂ inhibits growth. However, there is limited research on the relationship of its growth in certain environments, e.g., the envelope of building, where within building materials low O₂ and high CO₂ concentration may prevail (Jennings 1991).

2.4 Methods for fungal growth assessment

Fungi increase their biomass by increasing cell numbers, by extending and enlarging the hyphae, and by reproduction to increase the population. Fungal cell constituents, such as proteins, ergosterol, chitin, enzymes etc., increase correspondingly. Fungal

growth can be assessed by measurements of such constituents. The production of fungal constituents requires energy, which is provided by the fungal metabolism. Therefore, the metabolism level, measured as ATP content, respiration rate or heat production rate can also reflect the fungal growth. The production of fungal constituents and products needs raw material: the nutrient. The amount of nutrient utilised, or the substrate mass loss can also be used as a indices for estimating fungal growth (Carlile et al. 2001).

The methods for estimating fungal growth outlined above can be categorized as direct measurements (colony size, dry weight) and indirect methods (chitin, ergosterol, respiration etc.).

2.4.1 Biomass - Direct measurements

Visual measurements of growth

Colony size – colony diameter, colony margin

When growing on the surface of substrate, hyphae extend with the growth. The biomass is reflected in the colony size. Colony diameter can be measured with a ruler or a calliper and recorded at fixed intervals to be presented as a function of time.

Hyphal length

The hyphal diameter and length can also be observed with microscopic techniques. It is more precise than colony size estimation.

The above methods are simple to use and non-destructive. However, they are rough, and even if they can be used as indices of biomass (increase), the correlation of increase in colony size and hyphal length and real biomass is difficult to define (Frankland et al. 1990), and the methods cannot be used for growth within building materials.

Mass

Dry mass

The fungal colony, e.g., on an agar, can be collected by rinsing and filtering. It is then dried at a standard temperature for 24-45 hours before the dry mass is measured.

Measurement of fungal dry mass is direct and accurate. However, it is a destructive and time consuming method. The culture sampling must be complete and sampling will be difficult or impossible if the fungal culture grow on substrates such as wood.

Mass loss (substrate)

The breakdown of substrates used for fungi have also been used to estimate the fungal biomass or fungal activity (Carlile et al. 2001).

There are other methods to measure the biomass, such as counting of cell numbers. However, cell counting method is more applicable for unicellular organisms, such as yeast and spores, and cannot be used for mycelia fungi (Carlile et al. 2001).

2.4.2 Fungal constituents

Many fungal chemical constituents have correlation to the fungal biomass. Therefore they can be used as chemical markers for estimating fungal biomass or fungal activity.

Chitin

Fungi are the only microorganisms with chitin in their cell walls. It has been used for assessing fungal content in natural materials (Deacon 2001). Hydrolysis of chitin yields *N*-acetylglucosamine that can be estimated colorimetrically (Carlile et al. 2001). However, since the amount and composition of fungal cell walls varies with age, species and other factors, the amount of chitin does not bear a simple relationship to biomass (Nilsson and Bjurman 1998). Chitin exists in both living and dead fungal cells. Therefore, the measurement of chitin content cannot differentiate the dead mycelia from living ones.

Ergosterol

Ergosterol is a specific sterol component of fungal membranes. It is a particularly useful fungal marker molecule. Since ergosterol may decompose after the death of fungal hyphae, the ergosterol content is related to fungal living mass. Ergosterol concentration can be quantified by different methods (Newell 1992). Ergosterol can be extracted and measured by high performance liquid chromatography (HPLC) (Grant and West 1986; Nilsson and Bjurman 1990; Bjurman 1994; Fujiyoshi et al. 2000; Klamer and Baath 2004) and gas chromatography mass spectrometry (GC-MS and GC-MSMS) (Axelsson et al. 1995; Saraf and Larsson 1996; Saraf et al. 1997; Larsson and Larsson 2001).

Protein

Protein is part of the constituents of fungi, and therefore can be measured to estimate fungal biomass. Protein can be measured by fluorescent light (Chen et al. 2003).

Enzyme

Fungal enzyme activities can be used as indices of fungal biomass (Frankland et al. 1990). Laccase, fungal ligninases, carboxymethylcellulases, esterases, glutamate oxaloacetate transaminases and peptidases have been measured for estimating fungal mass. However, the correlation between enzyme activities to fungal mass is not stable (Newell 1992).

Quantification of adenosine triphosphate (ATP)

All living cells produce ATP as a form of energy packing and energy transport. ATP concentration is found in relatively constant proportions in all living cells. The basis of the ATP assay is its reaction with luciferin in the presence of the enzyme

luciferase. One photon of light is produced for each molecule of ATP hydrolysed and the emitted light can be measured with a photometer or scintillation counter (Herbert 1990).

There are also other methods for measuring fungal components. For example, quantification of mRNA by reverse transcription polymerase chain reaction PCR method has been used to estimate fungal biomass (Lamar et al. 1995). However, they will not be explained in details in this thesis.

2.4.3 Fungal activity

The more active the fungi are, the more growth or more future growth can be estimated. The activity is in the terms of fungal metabolic levels. It can be measured with various methods.

Respiratory activities

The rates of fungal respiration - consumption rate of O₂ and production rate of CO₂ - are good indices for fungal activity (Frankland et al. 1990). There are different possible methods for measuring fungal respiration rates. For example, O₂ and CO₂ sensors can be used. Respirometry has been used as well (Willcock and Magan 2001). Calorespirometric devices can also be used for measuring fungal respiration activities and thermal activity simultaneously (Wadsö et al. 2004b).

Thermal activity

Fungal metabolism produces heat, which is related to its activity. The heat production can be measured with calorimetric methods (Wadsö 1996; Wadsö 1997; Xie et al. 1997; Critter et al. 2001). Calorimetry is the central method used in this project. Calorimetric methods are described in detail in chapter 4.

2.4.4 Other methods

There are a number of other events in connection to fungal growth (or activity) that can be used to assess the state of fungi. For example has mycotoxin production and sporulation been used (Carlile et al. 2001; Wanyoike et al. 2002). These methods are more limited than the above methods as they assess specific events in the life of fungi, but they are very useful if one is specifically interested in these events or the effects of these events. For example is mycotoxin production a valuable measure in connection with investigations of connections between mould growth and health, e.g., in buildings.

2.4.5 Comparison of different methods

Results from different methods should not be compared uncritically as different methods can have quite different properties. When discussing a method the following points should be noted:

- Is the method destructive? If it is, the same sample can not be used for more than one measurement or for measurements of other parameters.
- Is the method direct, in the sense that it directly measures the factor one is interested in? Many methods to assess fungal growth or activity are indirect, e.g., the measurement of biomass by measuring ergosterol content.
- Does the method differentiate between dead and living cells? In some cases only living fungi (and living spores) should be counted (for example for assessment of pathogenic fungi); in other cases the total fungal biomass is of interest.
- Does the method measure *biomass* or *activity* (the rate of change of biomass)? This distinction is important even if both biomass and activity can be defined in different ways.

Table 2: Comparison of different methods to estimating fungal growth (activity)

Method	Fungal specific	Destructive	Measures only live fungi	Expensive instrumentation	Biomass or activity	Direct /indirect	Time
Visual	Yes	No	Yes / No	No	Biomass	Direct	Quick
Fungal mass	Yes	Yes	No	No	Biomass	Direct	Slow
Mass loss	Yes	Yes	No	No	Biomass	Indirect	Slow
Chitin	No	Yes	No	Yes	Biomass	Indirect	Slow
Ergosterol	Yes	Yes	Yes / No	Yes	Biomass	Indirect	Slow
ATP	No	Yes	Yes	Yes	Activity	Indirect	Slow
Enzyme	Yes	Yes	Yes	Yes	Activity	Indirect	Slow
Respiration	No	No	Yes	Yes	Activity	Direct	Quick
Calorimetry	No	No	Yes	Yes	Activity	Direct	Quick

3.0 Fungi in buildings

Fungal growth can be found on different building materials in different parts of a building. As discussed in chapter 2, fungal growth is mainly influenced by nutrients, humidity, temperature and O₂. The fungal growth in buildings is influenced by how the building fulfils such factors for fungi, i.e., fungal growth in buildings is influenced by building material properties (nutrients), indoor/construction humidity, indoor/construction temperature and O₂ concentration. Building materials (including substances absorbed on their surfaces) are the nutrition supply and building physics explain the water and temperature conditions indoors (Fig. 5).

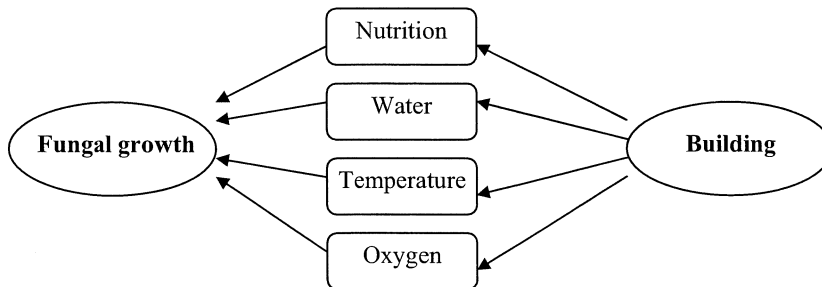

Figure 5: Key factors for fungal growth in buildings

3.1 The building

The purpose of a building is to fulfil the needs and requirements of its occupants and their activities, for example a temperature around 20°C, low draft, no very cold surfaces etc (Lunau 1992). Modern buildings are built using rather complex constructions containing many different materials in different layers, for example an outer wall can be made from bricks, two types of boards, mineral wool, wood, and a plastic foil. This is different from traditional buildings that were built with fewer materials in homogeneous constructions, for example massive brick and wood walls.

The structure of the building components, the materials and people's activities inside of a building determine which parts of the building that are more susceptible to fungal growth. In this chapter, some materials and their susceptibility to fungal growth are briefly discussed. Physical conditions, mainly temperature and moisture, are also discussed as the result of the building construction and human activities in the building.

3.2 Building materials

Fungal growth has been found on many different types of materials. Most commonly it is organic materials like wood, or materials with organic components like gypsum board (paper) that are attacked (Hyvarinen et al. 2002). However, one can also find mould growth on seemingly inert inorganic materials, probably because their surfaces absorb dust particles and in some cases contain substances like nitrogen that the fungi

need (Hyvärinen et al. 2002). Some common building materials in relation to fungal growth are discussed below.

3.2.1 Wood

Wood – usually from softwoods such a pine and spruce – was and still is a common material in buildings: structural components, doors, windows frames, floors, ceilings, interior decoration etc. Wood is natural organic material that has many good properties, such as high strength, good fire resistance and relative low price. However, its organic nature also makes it susceptible to fungal attack.

Constituents of wood

Wood consists of fibres, each with a wood cell wall surrounding a central cavity, the lumen (Fig. 6). Lumens are connected by pores (not shown in the figure). In the living tree the wood fibres function as transport channels for water from the root to the leaves by suction (underpressure) caused by the vaporization of water from the leaves (Zimmerman 1983). When the wood is dried, most of the lumen pore-membranes in softwoods are closed and its permeability to liquid water flow is greatly decreased. However, if the wood has been stored in water for long time, the pore membranes may be destroyed by bacteria very much increasing the permeability (Siau 1984).

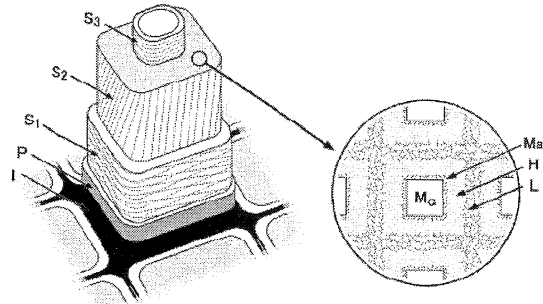

Figure 6: Microstructure of wood cell wall: (I) intercellular layer; (P) primary wall; (S1) outer layer of secondary wall; (S2) middle layer of secondary wall; (S3) inner layer of secondary wall; (Mc) crystalline region of microfibril; (Ma) amorphous region of microfibril; (H) hemicellulose; (L) lignin. (Nakano 2003)

The cell wall of wood is composed by the three natural polymers cellulose, hemicellulose and lignin. In wood, several cellulose molecules are arranged parallel to each other, like the strand of a sewing thread. These are called microfibrils (Wadsö 1993). Microfibrils are coated with hemicellulose and embedded in lignin as shown in Fig. 6.

Cellulose is a polysaccharide composed only of glucose units. It is the main constituent of wood, making up 40-45% of its dry weight. The cellulose is partly crystalline and partly amorphous. Many fungi produce cellulases that hydrolyse cellulose to cellobiose and glucose. Glucose can then be absorbed by the fungi as a carbon source (Prescott et al. 2003).

Hemicellulose is branched polysaccharide, or actually a group of polysaccharides, built from several different sugars, for example glucose, xylose, galactose, mannose, arabinose and 4-0-methylglucuronic acids of glucose and galactose (Viitanen 1996). Hemicellulose makes up about 25-30% of wood dry mass. Hemicellulose is degraded and used by many rot fungi (Carlile et al. 2001).

Lignin is an aromatic and amorphous polymer composed of phenylpropane units. The main role of lignin is to act as gluing material in the cell wall and to give sufficient rigidity to the cell wall (Viitanen 1996). The content of lignin in wood varies from 18% to 35% for different wood species. Most rot fungi cannot degrade the aromatic lignin; only a few specialist fungi like white rot can decompose lignin.

Wood and fungi

As discussed in Chapter 2, the two most important nutrients needed by fungi are carbon and nitrogen. The nitrogen is the most essential of the other nutrients as it is an essential part of amino acids, peptides and proteins. Wood is a rich carbon source for fungal growth, but it is poor in nitrogen. The carbon-nitrogen (C:N) ratio is in the order of 500:1, which is much lower than the requirement of about 30:1 for most fungi. However, rot fungi that use wood as nutrient sources are adapted to low-nitrogen substrates, for example by to some extent recycling nitrogen. Those fungi can grow inside of wood and degrade the wood cell walls. Other fungi (moulds) mainly grow on the surface of wood and do not degrade the wood cell walls as they are lack of strands which can penetrate wood pores and have no enzymes can degrade wood cells as rot fungi. They live on soluble sugars and other compounds from the wood itself or from dust etc. absorbed on the surface.

Wood water sorption

A living tree in the forest contains a lot of water that has to be dried away before the wood can be used in construction. Today this is normally done in drying kilns at high temperature until the wood reaches about 12% moisture content.

As shown in Fig. 7 wood can absorb substantial amounts of water vapour. At 100% relative humidity (water activity 1.0), the moisture content (mass water per mass dry material) of wood is about 30%. Up to this point most of the water is hydrogen bonded to groups in the wood cell wall, mainly to amorphous parts of the cellulose and to the hemicelluloses (capillary condensation is not the active sorption mechanism in wood except at high relative humidities). However, because of its high porosity, wood can also hold large amounts of free water in its pores and the water content (mass of water per mass dry wood) of wood can reach as high as 200% (Wadsö 1993).

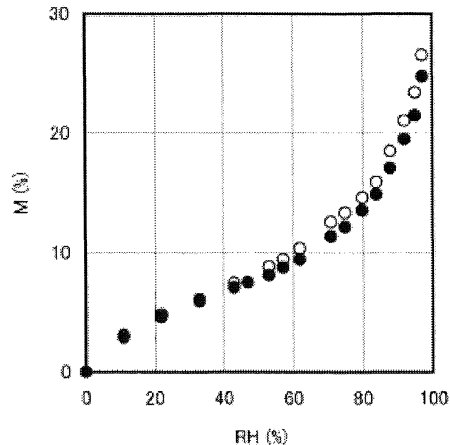

Figure 7: Wood showing the equilibrium moisture content as a function of relative humidity (Nakano 2003)

The diffusion of water vapour and the permeability of liquid water are quite different across the fibres (the radial and tangential directions) and along the fibres (the longitudinal direction). Typical diffusion coefficients of softwoods are $0.3 \cdot 10^{-9} \text{ m}^2/\text{s}$ in the radial and tangential directions and $1.5 \cdot 10^{-9} \text{ m}^2/\text{s}$ in the longitudinal direction

(Wadsö 1993). Liquid water permeabilities in the longitudinal direction are much higher than in the other directions (Siau 1984). Because of this it is essential that the end parts of wood boards are protected, especially from liquid water, such as rain and condensation.

Wood-based material

Wood-based board materials have become very popular. They are usually divided into the following groups: 1. Fibre-boards of different densities made by pressing together wood fibres under high temperature and pressure (no added adhesive). 2. Particle boards in which wood particles are held together with an adhesive. 3. Medium-density fibre-board (MDF) in which fine wood particles are held together by adhesive. 4. Plywood in which veneers are held together by adhesive. Except for the rare cases in which wood-based boards are treated with fungicides, their resistance to attack by fungi is similar to that of wood (Wang 1994).

3.2.2 Gypsum board

Gypsum board, which was invented in late 19th century, saw industrial production being started in 1901 in USA. It is a popular building material worldwide that is used mainly for interior walls as it has a very flat and smooth surface. Gypsum board (also called plasterboard, drywall or wallboard) has a gypsum core and paper facings. In its natural state gypsum is the dihydrate of calcium sulphate ($\text{CaSO}_4 \cdot 2\text{H}_2\text{O}$) that is mined as white soft crystalline rock or sand. Most of the chemically bound water is lost and a hemi-hydrate ($\text{CaSO}_4 \cdot 0.5\text{H}_2\text{O}$) is formed when gypsum is heated to about 200°C , but the dihydrate is quickly reformed when the hemi-hydrate is mixed with water. Because of this, gypsum can be re-formed easily as a natural non-hydraulic binder.

Gypsum has a number of advantages, such as relatively low bulk density, rapid drying and hardening with negligible shrinkage, resistance to insects and rodents and low energy input in production (Duggal 1998) that make it a popular building material. The boards also have good sound absorbing capacity, good fire resistance and very good surface finish. Both gypsum and paper are abundant and relatively inexpensive materials. As mentioned above, gypsum boards are mainly used as surface layers in ceilings and on walls. However, treated with a water-proof membrane and covered with tiles are plastic covers, double gypsum boards are also used for constructing bathroom walls, and some gypsum board qualities treated with hydrophobic compounds are also used as exterior layers during the construction of a building, later to be covered with bricks, wood panels etc.

As paper is an organic and renewable material, the production of gypsum board requires relative lower energy input and certain kinds of gypsum boards are recommended as environmental friendly construction materials for building constructions (Anink et al. 1996). However, because of its organic nature, severe mould growth have been found on the paper of gypsum boards exposed to humid environments, for example in leaking bathroom walls.

Both gypsum and paper are porous and hydrophilic materials that can absorb moisture and get high water contents in humid environments. When wet, gypsum boards will lose their rigidity and be deformed. Paper is an organic material which mainly

contains cellulose, which is a good carbon resource for fungal growth. Gypsum has abundant calcium, which is a nutrient for some fungal growth, such as *S. lacrymans* and the natural gypsum is not pure calcium sulphate dihydrate, but may also provide micro-nutrients for mould growth.

Many occurrences of mould – some with the “toxic mold” *Stachybotrys chartarum* – have been reported on water damaged gypsum boards (Andersson et al. 1997; Pasanen et al. 2000; Hyvarinen et al. 2002). There are various reasons for gypsum board water damage: for example that already wet gypsum board was used for construction as the boards were exposed to rain during transportation or when they were handled on the building site. Inside a building, water can leak through the tile joints in bathroom walls made of gypsum boards.

3.2.3 Wall surface material: wallpaper and paint

Wallpaper is widely used on interior surfaces in buildings. Mostly it is made of paper, relatively inexpensive and is considered to be an environmental friendly material due to it is organic nature and with relatively clean production process (Anink et al. 1996). It mainly consists of cellulose that is a carbon source for fungi. Cellulose-based organic adhesives used for wallpaper may also be a nutrient source for fungi (Adan 1994). The back of wallpapers (in the adhesive) is a common niche for mould growth.

Water-based paints are most commonly used in Europe nowadays as organic solvents give occupational health problem and are not environmental friendly. However, water-based paints may be more susceptible to mould growth (Nielsen 2001). There is also commercially available environmental friendly paint from natural materials like eggs that could be suspected of supporting mould growth under humid conditions.

3.2.4 Concrete

Concrete is a composite man-made material and the most widely used building material today. It is made by mixing cement, water and aggregate (sand and stone) of different sizes. After mixing the cement reacts with the water forming a strong solid end product called hydrated cement paste that acts as a binder for the aggregate (Duggal 1998). In normal concrete a large part of the mixing water remains in the concrete and has to be dried out to prevent moisture problems in the buildings. There are also modern types of concrete with low water content (self-desiccating and high performance concretes) in which the mix water is consumed during the hydration.

Most of fungi prefer to grow at neutral pH or in slightly acid environments (optima pH 5.0-7.0) (Deacon 2001). The pH of humid concrete is much higher than this; new concrete has a pH of more than 13, but this will go down on the surface as the concrete reacts with the CO₂ of the air (carbonation). Carbonated concrete has a pH of about 7. It has been shown that mould can grow on alkaline substrates and also on the surface of concrete. There are studies showed that some mould fungi can degrade concrete (Gu et al. 1998). This is then probably caused by excreted acids that can dissolve the cement paste in the concrete.

Mould growth on concrete surfaces is probably only possible if the concrete surface is dusty or soiled as the concrete itself cannot provide any carbon sources. Whether

there any components of the concrete itself that provides nutrients for this growth is not known, but it is possible that mould can find, e.g., nitrogen on concrete surfaces.

3.2.5 Other materials

Moulds can grow on surfaces of all types of non-toxic materials, provided they can find nutrients there. It has also been reported that some fungi can degrade the ester-based plasticizers in polyvinyl chloride (PVC) (Webb et al. 2000); a polymer that is commonly used in plastic flooring in buildings.

3.3 Building physics

Temperature and humidity distributions in a building are obviously important when it comes to predicting the growth of mould and rot fungi. Normally the temperature is treated first as it partly determines how the humidity situation will be. Here I will give a short introduction to the factors that govern temperature and humidity distributions in a building.

3.3.1 Heat

Heat transfer

There are three ways of heat transfer: conduction, convection and radiation. A building exchanges heat with its surroundings in these three ways, in the form of heat transmission, ventilation and radiation (Hagentoft 2001) as shown in Fig. 8.

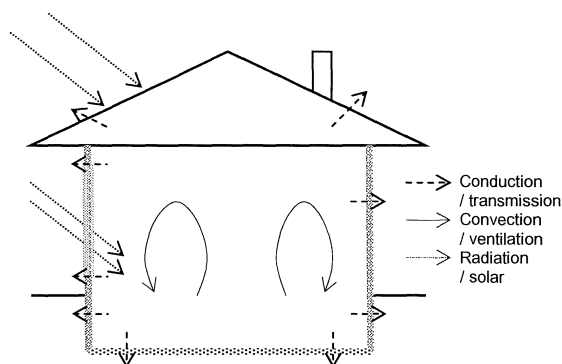

Figure 8: Heat flow in a building

Heat conduction (transmission)

When there is a temperature difference there is heat transmission (conduction). Heat flows from a higher temperature to a lower temperature, for example from a 20°C indoor climate to a -20°C outdoor winter climate. This is also called the heat loss of the building. The rate of heat transmission depends on the thermal conductivities of the wall material and their thickness. For example the thermal conductivity of concrete is higher than that of brick, which is higher than that of gypsum boards and wood. Insulation materials such as mineral wool and expanded/extruded polystyrene are the materials with lowest thermal conductivities. The thicker the insulation of a wall is, the less heat will be lost. Therefore, materials with low thermal conductivities and insulation materials are used for external walls. The temperature change through an external wall (a layer of gypsum board, insulation material and external bricks) is shown in Fig. 9.

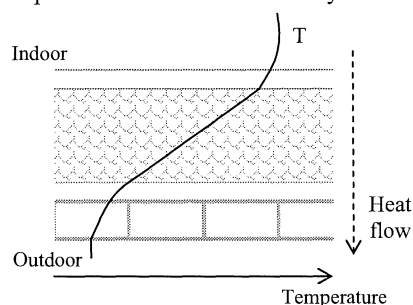

Figure 9: Schematic outline of the temperature through an external wall

Thermal bridges occur at places where the thermal conductance is higher than for the rest of the construction (Hagentoft 2001). This is typically at junctions between building components or where the building structure changes composition. At corner of the walls, the heat loss is a combined effect from heat loss of both of the walls as shown in Fig. 10. The heat loss at a corner is therefore higher than for the rest of wall.

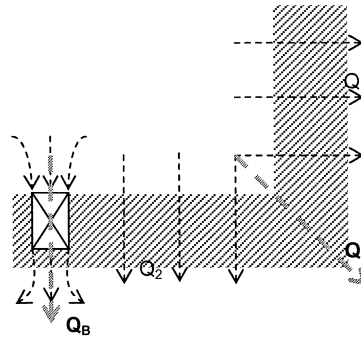

Figure 10: Thermal bridge (Q_1 , Q_2 , heat loss through wall. Q_B : heat loss through cold bridge, Q_C , heat loss through corner)

Thermal bridges cause heat leaks and higher energy consumption, but they also give lowered temperature on indoor surfaces, for example where a wood stud is placed in the insulation. The heat loss rate is higher at such spots, such as Q_B in Fig. 10.

Heat convection (natural and forced ventilation)

Heat is also transferred within the building due to convection of the air. There are two types of convection. The first one is natural convection caused by the air density due to temperature differences. The second one is called forced convection, caused by pressure from fans, wind etc. (Hagentoft 2001).

Ventilation is a significant path for heat loss from a building, but it is of course necessary with ventilation to guarantee the air quality of the building occupants. Depending on the type of ventilation system, when cold air is brought inside a warm building, the entrance point for the cold air is also a cold spot in the building, for example at leaks at the frames of windows and doors, and at ventilation inlets. To decrease energy consumption it is common to pass the outgoing air through a heat exchanger that takes some of the heat from the air leaving the building and transfer it to the fresh air coming into the building.

Radiation

When radiation strikes a material surface, part of it is reflected, part is absorbed and part is transmitted when the material is transparent at the wavelength. The radiation most relevant to buildings is solar radiation. A dark roof can reach high temperatures when the solar light is strong due to most of the solar radiant energy being absorbed by the dark roof material. In the mean time, when striking glass, most of the radiant energy is transmitted through the transparent glass and later absorbed by the materials inside the building (Hagentoft 2001). Therefore, the temperature of such building parts will increase ("the greenhouse effect").

A second important type of radiation is that from a building to the clear night sky. The sky can, e.g., on a winter day be seen as a cold surface, having a temperature well below the air temperature. A roof or a wall can thus reach temperatures below the dew point (temperature) so that significant amounts of water can condense on its surface.

Heating system

No matter how good a building is insulated, in a cold climate there are always heat losses. As the optimal thermal environment for humans is about 20°C, a heating system is necessary. There are different types of heating systems: traditional hot water heat radiators are placed below windows; in many Swedish buildings the same radiator placement is used for electrical radiators; in the last few years floor-heating (electrical or with hot water) has become more popular.

Indoor surface temperature distribution

Although there are various methods in keeping the room temperature at a desired level in a building, it is not possible to have the temperature evenly distributed due to the various heat loss mechanisms mentioned earlier in this chapter. Water will condense or be absorbed on parts of indoor surfaces with lower temperature than the air temperature in the room. Such cold spots are located at thermal bridges, for example at corners and where the thermal resistance of a building part is lower than average. Typical examples of the latter are metal objects (nails, screws) passing through a wall and load carrying parts (wood, concrete, steel) that have lower thermal resistance than the insulation. Even such minor details such as an electricity plug in an external wall may penetrate into the insulation and thus be a cold bridge.

An example of how high the indoor surface temperature variation can be is illustrated by average values from measurements made by Burke and colleagues in a multi-family house in southern Sweden in January (Burke et al. 2002). The average indoor air temperature was 23°C, but the surface temperature of the joints of external walls and the ceiling was about 17°C with the corner connecting two external walls and the ceiling being about 15°C. The frames of doors and windows had temperatures as low as 12°C. At one corner of a window joint, the temperature was even lower than 10°C.

3.3.2 Moisture

Definition of moisture terms

There are several terms used to describe the state of water in air and in materials. These terms are all descriptions of the state of water. It is partly determined by convenience in a certain situation and partly by tradition on which term to be used. For example, soil and plant scientists prefer to use *water potential* that is convenient for high moisture states and where the water state is influenced by many factors, but building material scientists usually use *relative humidity* that is convenient at lower moisture states when the water state is mediated through the gas phase. As the terms below are closely related to each other it is essentially possible to convert from one to any other if one likes (there are some problems, for example for systems showing sorption hysteresis). Note that the nomenclature may vary between different fields of science for, e.g., moisture content.

Vapour content v

The vapour content (or water vapour content) v (g/m^3) is the mass of water per volume of air. Vapour content is convenient when working with water vapour transport, e.g., in buildings, as the vapour content contains the mass of interest in mass transfer calculations. The maximal vapour content, called the saturation vapour content, is a function of temperature (Fig. 11). At room temperature (20°C) the saturation vapour content is about $20 \text{ g}/\text{m}^3$. Vapour contents are usually not directly measured, but are calculated from relative humidity and temperature measurements or dew point measurements.

Vapour pressure p

The (water) vapour pressure p (Pa) is the partial pressure of the water gas in air. It is related to the vapour content v through the ideal gas law (note that $v=nM_w/V$).

$$p = \frac{v}{M_w} RT \quad (1)$$

Here, n (mol) is the number of mole, M_w (g/mol) is the molar mass, V (m^3) is the volume, R ($8.314 \text{ J}/\text{mol}/\text{K}$) is the gas constant, and T (K) is the temperature. The maximal vapour pressure, called the saturation vapour pressure, is a function of temperature. At room temperature the saturation vapour pressure is about 2700 Pa . Vapour pressures are not directly measured, but are calculated from relative humidity and temperature.

Relative humidity φ

The relative humidity is frequently used in building material science, and also in, e.g., pharmaceutical science. It is the fraction of the maximal possible water content (or vapour pressure) at a certain temperature. It is thus calculated as a ratio of the present vapour pressure and the vapour pressure at saturation:

$$\varphi = \frac{p}{p_{sat}} = \frac{v}{v_{sat}} \quad (2)$$

Here, v and p are the vapour content and the vapour pressure, respectively, and 'sat' refers to the saturated state. The relative humidity is often called "RH" and given in percent:

$$RH = \varphi \cdot 100\% \quad (3)$$

The relative humidity of air can be measured by several methods (resistive or capacitive probes, psychrometers and dew point sensors).

Water activity a_w

Water activity (a_w) is related to relative humidity, but has a more general definition. It is commonly used in food science and microbiology. The water activity describes the escaping tendency of water in a system (or the ease with which it can be removed and

utilised, for example, by mould). Water activity has a strict thermodynamic definition as the ratio of the fugacities of the water in question and pure liquid water. However, in all situations where microbiological growth on buildings materials occur, the fugacities can be approximated with the corresponding vapour pressures (the error will be not be higher than about 0.1% (Gal 1972). The water activity will thus have the same numerical value as the relative humidity:

$$a_w = \varphi \quad (4)$$

There is, however, a distinction between these two measures of water vapour state: the definition of relative humidity is only valid for water vapour (in air), but the thermodynamic definition of water activity is valid for all water; vapour, liquid and bound. One can thus state that a material has a certain water activity, but purists may protest if one says that a material has a certain relative humidity. If one does this, as building material scientists often do, one either means that the statement is valid for the vapour in the pores of the material (most building materials are porous) or that the statement should be understood such as that *if* the material at the present humidity state would be in equilibrium with air, that air would have that relative humidity. The water activity of a material cannot be directly measured; it is normally found from measurements of equilibrium relative humidity.

Moisture content u

The moisture content u (g/g) is defined as the mass of water divided by the mass of the material. It is easy to measure and is used in many fields of science. One can either define the moisture content based on the dry mass or the total mass including the water. The dry mass definition is most common and is used in building material science. It is easy to convert between the two types of moisture contents:

$$\frac{1}{u_{wet}} = \frac{1}{u_{dry}} + 1 \quad (5)$$

A problem is that sometimes it is not stated in papers which of the two definitions were used. The moisture content is normally found by weighing samples before and after they are dried at about 100°C.

Water potential Ψ

Water potential is commonly used in soil and plant sciences and in other biological sciences. The water potential is an indicator of how hard it is, e.g., for a mould, to extract water from a certain place. It is essentially the overall Gibbs energy G (J/mol) of the water, but for historical and practical reasons this is instead given as a pressure called the water potential Ψ (Pa, but usually given in MPa). An advantage with water potential is that it makes it possible to separate the effect of different factors on the state of water. For example if the state of water in a soil is influenced both by external pressure and by solutes one can write:

$$\Psi = \Psi_0 + \Psi_P + \Psi_{\Pi} \quad (6)$$

Here, Ψ is the water potential of the soil, Ψ_0 is the water potential of pure water (a reference state), Ψ_p is the pressure potential and Ψ_{π} is the chemical potential. Water potentials are normally negative and the water tends to flow in the direction of decreasing water potential. Water potentials have not been used in the present work.

The psychrometric chart

The psychrometric chart is a convenient representation of the relations between vapour content, relative humidity, temperature etc. The saturation water vapour content depends on the temperature due to the liquid-gas equilibrium for water and it increases with temperature. When the temperature of a gas containing water vapour is changed, the relative humidity will also change. The temperature at which a certain vapour content equals the saturation vapour pressure is called the dew point. At temperatures below the dew point water will condense. This is an important process as much larger amounts of water can be deposited on a surface by condensation that is normally absorbed from the vapour phase. Growth of mould and rot fungi is often caused by condensation. The relationship between vapour content, relative humidity and temperature can be drawn in a psychrometric chart as shown in Fig. 11.

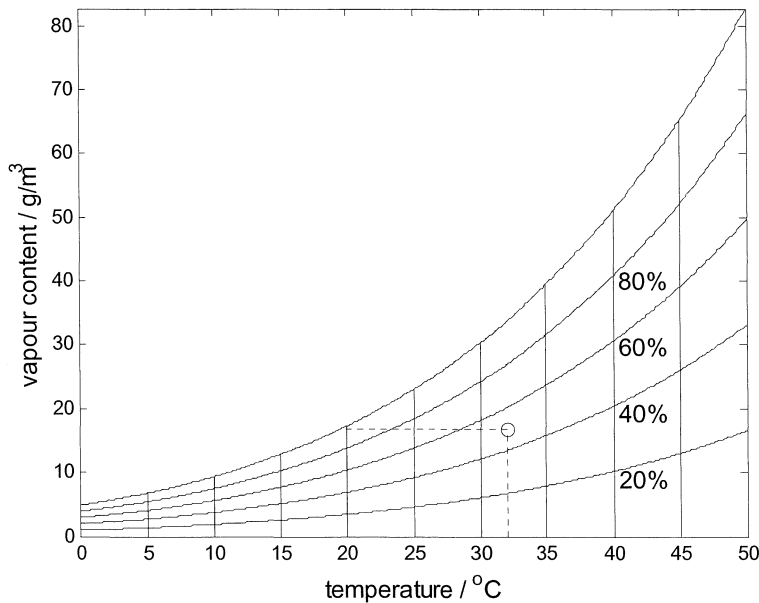

Figure 11: A basic psychrometric chart. The top line shows the saturation vapour content and the lower lines show the vapour content at 20 to 80% relative humidity. The dew point (temperature) for a certain temperature-vapour content state is found by traversing horizontally to the left until one meets the saturation line. The dotted line shows how this was done for 50% relative humidity at 32°C. The corresponding dew point is about 20°C.

In a building the vapour content can usually be considered to be quite the same in the whole building. An uneven temperature distribution in a building will then cause an uneven relative humidity distribution (along a horizontal line in psychrometric chart). The house that Burke and other researchers investigated (Burke et al. 2002) has the average room temperature of 23°C with some cold spots with temperature of 10 to 15°C. When the vapour content is 8 g/m³ (average indoor vapour content level in Southern Sweden in January, Fig 13), the relative humidity in the centre of the room is about 40%, about 65% at the 15 °C and about 85% at 10°C, which is higher than the minimum RH required for mould growth (about 70% RH). Therefore the risk for mould growth is high at such cold spots. If temperatures as low as 7°C would have been found (the dew point corresponding to 8 g/m³) such surfaces would have had condensation.

The sorption isotherm

The sorption isotherm shows the relation between relative humidity and moisture content at equilibrium for a material, i.e., the relation between water activity and moisture content. Fig. 7 shows an example of a sorption isotherm measured for wood and Fig. 12 shows the sorption isotherm for a cement based self-levelling flooring compound. The latter diagram also shows pronounced sorption hysteresis (separate curves for absorption and desorption); a common phenomena for building materials, foods, textiles etc. Sorption hysteresis is possibly a cause of the lower mould activities seen in absorption than in desorption (at the same relative humidity) in Figs. 32-34 in chapter 5.

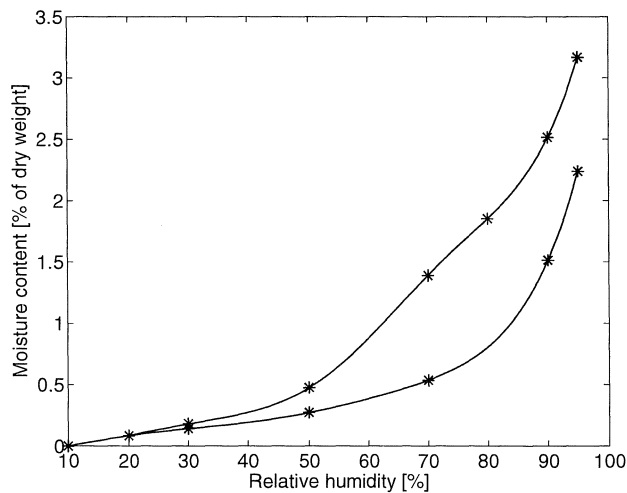

Figure 12: Sorption isotherm of cement based self-levelling flooring compound. Stars are measured values. The upper curve is for desorption and the lower curve is for absorption. The samples were not dried below 10% RH as this material then shows irreversible changes (“dry weight” is mass at 10% RH) (Anderberg and Wadsö 2004).

Sorption hysteresis also complicates sorption calculations as many real cases involve oscillating moisture states and then also scanning between the limiting absorption and desorption limbs. Scanning curves are poorly known, but can have profound influence on chemical and biological deterioration processes in some cases. If a small amount of liquid water is added to a drying material there is a substantial difference in the calculated increase in relative humidity (water activity) if one only works with one isotherm or if one works with scanning between two limiting limbs as it is then found that the initial scanning curve is almost horizontal (Anderberg 2004).

Water sources in buildings

Moisture in the air of a normally functioning building mainly comes from two sources: outdoor air humidity and indoor activities. The indoor air is always originally taken from the outdoor air. Therefore, the outdoor humidity is brought inside of the house. In Sweden, the outdoor water vapour content is higher in the summer and lower in the winter. The outdoor relative humidity is lower in the summer and higher in the winter due to the low temperature in the winter (Nevander and Elmarsson 1994). Figure 13 gives an overview of temperatures and indoor and outdoor relative humidities in southern Sweden.

When indoors, moisture is added to the outdoor vapour content from people's everyday activities, such as breathing, cooking, bathing, washing and drying clothes. It is normally considered that indoor sources adds about 4 g/m^3 (Nevander and Elmarsson 1994) extra moisture content to the indoor air, but this can vary greatly depending on the ventilation and the activities in a building.

There are some other sources of water that are negligible in well designed and normally functioning buildings, but that can bring large amounts of water into a not so well functioning building. For example, leaking water pipes and leaking window sills can bring large amounts of liquid water into a construction. In most cases the indoor air humidity will not change much when a leak occurs, but the interior moisture state in a construction can increase significantly.

Moisture can also come into a building when it is being constructed. Many building materials contain large amounts of water that have to be dried out before the building is in its "moisture steady-state" where it can function well for long periods of time. Two examples of building materials that can contain large amounts of water are concrete and wood. All normal concrete is made with much more water than is used in the hydration reaction. Part of this unbound water has to be dried out to get the relative humidity of the material down to levels where it will not damage other materials because of its high pH or cause other problems. Wood is normally dried to a state similar to that that it will have in the finished building, but if badly handled on the building site it can absorb rainwater which is brought into the new construction and that, in some cases, can take long time to dry out. Similar problems can occur with other materials, for example gypsum boards.

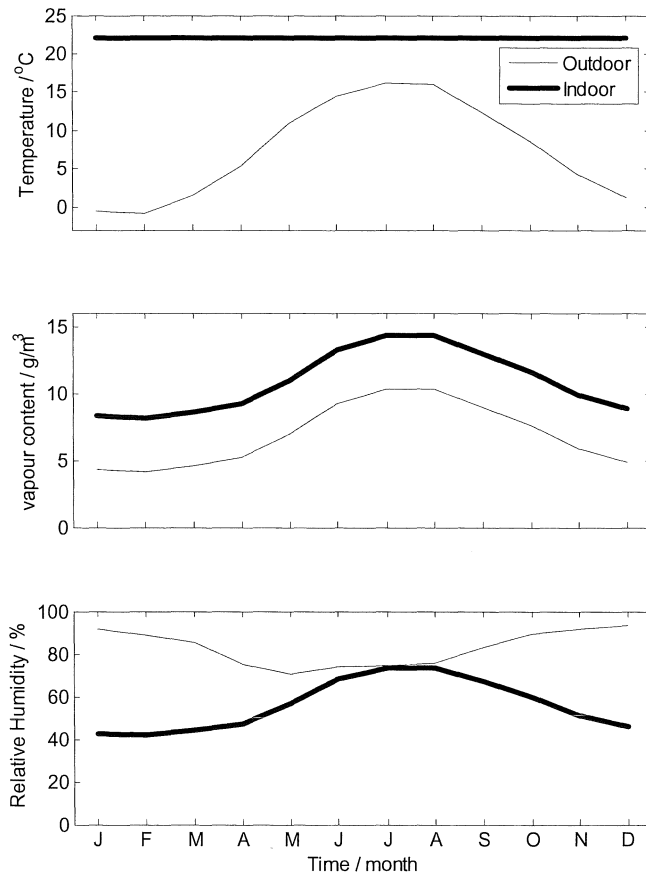

Figure 13: Temperature, vapour content and relative humidity yearly distribution in South Skåne, Sweden (data from Sturup (Nevander and Elmarsson 1994))

3.4 Limiting factors for fungal growth in buildings

As stated previously, for fungal growth to occur four factors are important: temperature, humidity, nutrients and O₂. The temperature inside buildings is normally in the order of 20°C all year around and even inside most parts of building parts like walls the temperature is above at least 10°C for the major part of the year. Therefore, the temperature in our buildings is quite suitable for fungal growth, but the temperature level will influence the rate of growth.

The humidity requirements for moulds and rot fungi are quite different:

- Moulds, that can grow at relative humidities above about 70% (Grant et al. 1989), presents a special challenge as such humidities regularly occur in many parts of a building. Some building parts like crawl spaces, bathrooms and external panels will always be exposed to humidities above 70% for shorter or longer times. This will also be true for other parts of buildings, like winter time interior walls inside cold bridges, and the lower parts of windows with condensation. Other parts of our buildings like interior walls and well insulated ceilings will not see relative humidities above 70% (except maybe on warm summer days). As most exposures to high relative humidities do not occur all year around, the question of if the relative humidity is high enough for mould growth is not only a question of RH-level, but also of time. Typically, exposures to high humidity occurs on an annual (crawl spaces) or daily basis (bathrooms). Fungal growth probably cannot be treated as a function of constant environmental conditions. Dynamic environmental conditions is an interesting topic for research, and modelling of mould activity must include a history dependence.
- As discussed in chapter 2, rot fungi normally needs high moisture contents (essentially free water) in a building component to grow. They will thus not grow in a well functioning building, but usually occur after leakages or condensation because of faulty constructions. The dry rot is special in that it can transport water through hyphal strands from a water source to a destruction site in a building. Because of this it can spread quickly in a dry building, but its growth starts in a point of high moisture content like for other rot fungi.

Normally there is organic material and dust everywhere in a building that will provide enough carbon and other nutrition sources for mould growth, but the rate of growth is influenced by the nutritional status of the substrate in a building. Rot fungi are adapted to degrade wood, so if they find this they have the nutrients they need.

Since buildings are normally ventilated in order to provide enough O₂ and low CO₂ for building occupants. Building materials are normally porous materials, oxygen levels are probably high enough for fungal growth in all parts of a building as most fungi can grow well in O₂ level down to a few percent in the atmosphere. Especially rot fungi are well adapted to growing at low O₂ and high CO₂ environments inside the wood they attack.

The question of which one is the limiting factor for fungal growth in buildings is difficult to give a general answer to. It is clearly so that low humidities is the only way to completely stop fungal growth in buildings, and in this respect humidity is the limiting factor, but if humidity is available, temperature and nutrients are important and will limit the growth. Oxygen is probably the only factor of the discussed four factors that seldom is a limiting factor in buildings.

3.5 Modelling mould growth in buildings

In this section modelling is limited to mould growth, which is of more importance to model than the growth of rot fungi. Some examples of previous activities in the field are discussed on how the modelling of fungal growth in buildings can be made.

3.5.1 Previous measurements and modelling of mould growth

Ayerst

Already 1968, Ayerst measured growth rates as a function of temperature and relative humidity for a large number of mould fungi growing on agar (Ayerst 1969). He presented his results as *isopleths* (meaning lines that connect points of the same value, cf. *isotherms* that connect points with the same temperature) (Fig. 14). His results are still used to show the dependence of mould growth on temperature and relative humidity.

Nevander and Elmarsson

Nevander and Elmarsson compiled experimental data into a diagram showing the probability of getting mould growth on wood as a function of temperature and relative humidity (Nevander and Elmarsson 1991). This diagram was useful and visualised the problems involved in modelling fungal growth: it is highly dependent of two primary factors: temperature and relative humidity, but it is also dependent on a number of other less well defined factors (hence the probabilistic of mould growth) (Fig. 15). However, this diagram is not useful in simulating mould growth as it has no time scale.

Adan

Adan introduced the term Time of Wetness (TOW) to consider the exposure time factor and took moisture diffusion into account. The TOW is the number of hours above a certain high relative humidity per 24 hours. The mould growth was observed with the factor of TOW and exposure days (Adan 1994).

Viitanen

Viitanen built the model of mould growth on wood as a function of time and relative humidities. He categorised the mould growth to 7 classes (mould indices): from 0-6 as indices of the percentage (0-100%) of coverage by mould growth and build model of mould growth as functions of relative humidities and time (Fig. 16) at certain temperature (Viitanen 1996).

Sedlbauer

Sedlbauer adjusted data from the literatures and built a model called Lowest Isopleth for Mould (LIM) (Fig 17). He has also published a model of mould growth based on simulations of microclimate coupled with a sorption model for mould spores germinations in which he models the water diffusion through the spore walls for spore germination (Sedlbauer 2001).

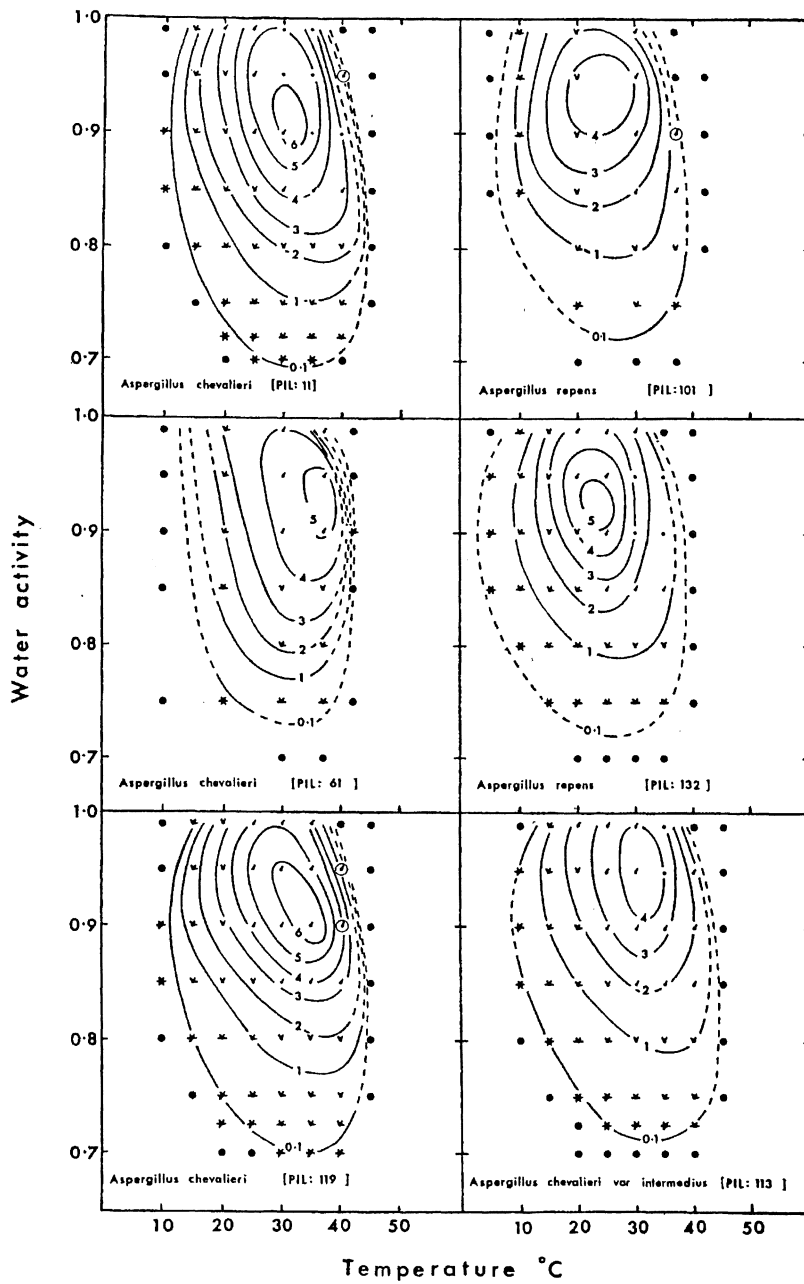

Figure 14: Mould spore germination times and rates of growth (mm/day) of *Aspergillus chevalieri* and *A. repens* (Ayerst 1969)

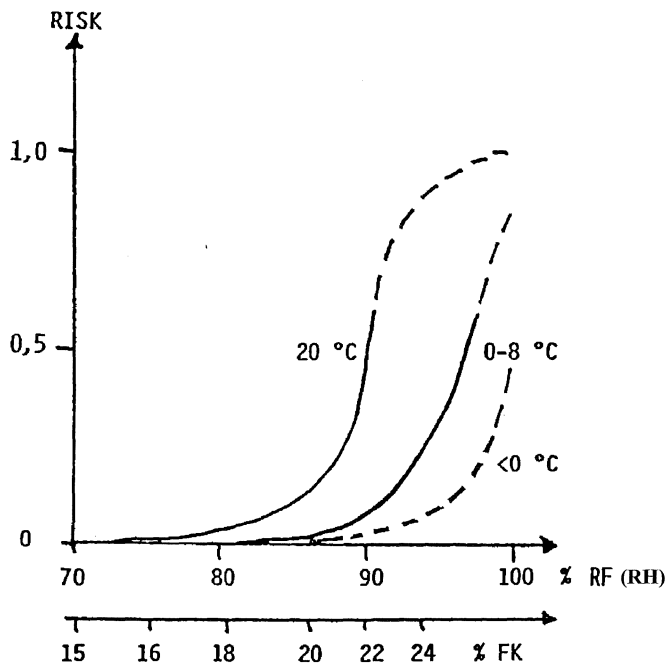

Figure 15: Risk for mould growth at different humidity and temperature level (Nevander and Elmarsson 1991)

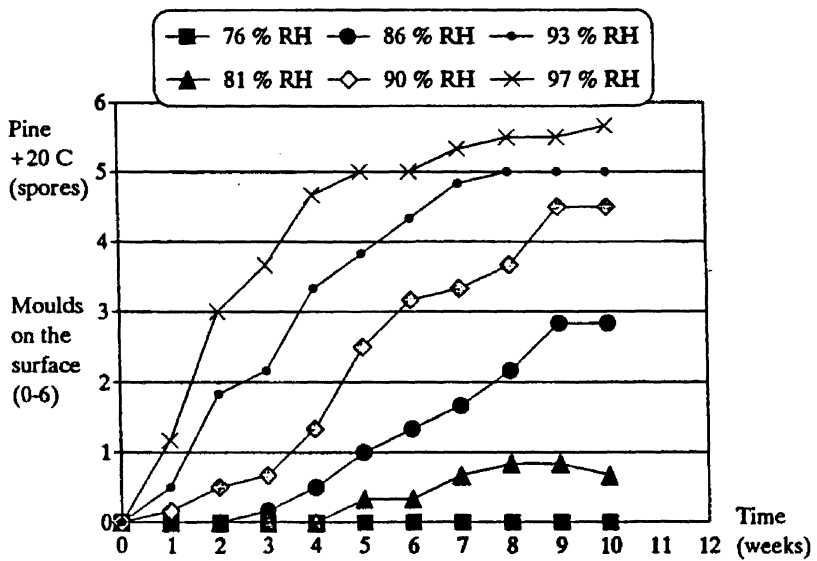

Figure 16: Mould growth on pine sapwood at temperature of 20°C (inoculated with spores) (Viitanen 1996)

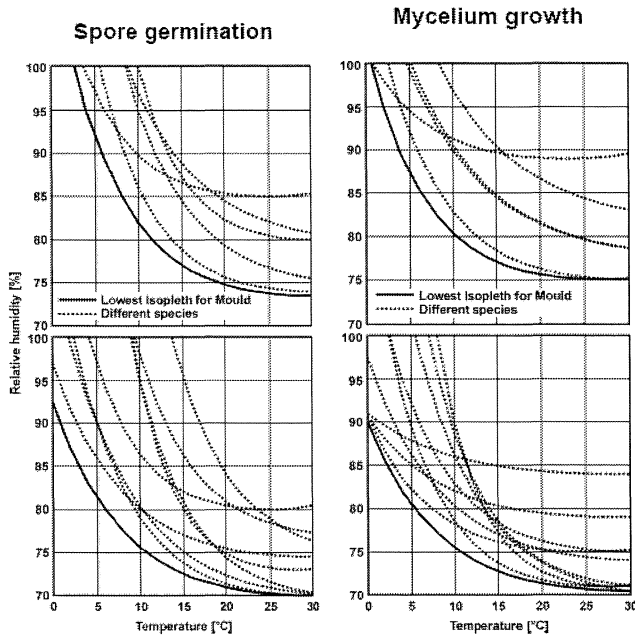

Figure 17: Isoleths for spore germination and mycelia growth of mould fungi and the Lowest Isoleth for Mould (LIM) resulting from that (Sedlbauer 2001)

3.5.2 Modelling mould activity

In the present work we see the modelling of mould growth as a four-step activity:

1. One first has to define growth and find a method to measure it. It has been common to work with visual methods, for example hyphal elongation in mm/day, but other methods like mycotoxin production may be more relevant when it comes to predicting health effects. In the present work we work with quantifying the heat production from the fungal respiration by isothermal calorimetry. We prefer not to say that we are measuring fungal *growth*, but call it a way of measuring fungal *activity*. We do not say that it is the best way, as all methods have their advantages and disadvantages. The advantage with isothermal calorimetry is that it enables us to continuously measure activity under changing environmental conditions of the same object (sample). For one sample we can write this as $P(T, \varphi, \dots)$, where $P(W)$ is the thermal power of a sample as a function of temperature T , relative humidity φ , and other parameters. A drawback with isothermal calorimetry is that it is not trivial to correlate calorimetric results with more common measures of growth rate like hyphal elongation. We see calorimetric measurements as giving the relations between activities under different conditions. We can for example measure $P(T=20^\circ\text{C}, \varphi=0.80)$ and $P(T=15^\circ\text{C}, \varphi=0.80)$ on the same sample, and thus calculate the relation between the growth rate of the fungi at 20 and 15°C (at $\varphi=0.80$). More generally we can generate functions $f = P(T_1, \varphi) / P_0(T_0, \varphi, \dots)$, where P is the activity of the fungi and P_0 is the activity of the fungi at a reference state, for example at 20°C, $\varphi=0.90$.

2. The second part of modelling of fungal growth (activity) in buildings is to define the temperature and humidity boundary conditions for the construction part of interest. Such boundary conditions can either be measured data series or expressions based on current knowledge. In very few cases can constant boundary conditions be used.
3. The third part is to build or find a software model with which one can calculate dynamic temperature and humidity conditions in a construction part of interest using the boundary conditions (and initial conditions). Today there are several such software for one-, two- and three-dimensional calculation, but it may not be trivial to apply them to a certain problem. It should be noted that it is probably in quite many cases, for example for walls, enough to work with one-dimensional calculation as there are large uncertainties in material parameters etc.
4. The fourth and final step is to use the results from the simulation as input to the f -function developed in step one to calculate an integral measure of fungal growth (activity) over a time period, for example a year. For calorimetric measurements the integral measure is heat Q (J) which is a convenient measure of how much mould respiration that has taken place (note the similarity between this and the heat evaluation of the measurements done for paper II). This heat is a measure of total respiration over the chose time period. The final result from a series of simulations can for example be heats Q for a series of insulation thicknesses L : $Q(L=10\text{ cm})$, $Q(L=15\text{ cm})$, $Q(L=20\text{ cm})$, etc. From this one can draw conclusions, such as “increasing the insulation form 10 to 20 cm, results in 60% reduction in mould activity”.

It should be noted that the above method based on calorimetry may seem to be limited by the fact that it is not possible to state how much mould one will actually get. However, no methods can do this as mould growth is a function of many complex factors, such as previous degrading light exposure of material surfaces, absorption of dust/soil on surfaces (and the nutrient content of this), etc. It is enough challenge today to model the *relative* mould growth (activity). In the future correlations may be established between calorimetry and other measures of mould growth. One step in this direction is in paper II where a correlation between heat measurements and ergosterol quantification is made.

Nothing in the above method is specific to building materials, and the general method, once developed, will work just as well in food science, soil ecology and textile science.

In the above description of modelling nothing has been said about a complicating factor: history dependence. It is quite probable that the activity of a mould is not only a function of the present environmental parameters, but also of the environment history. For example, it has been shown that a rot fungus exposed to high temperatures may need several days to recover from this (Xie et al. 1997). If a fungus is exposed to optimal conditions 95% of all the time but to a daily near lethal climate during 5% time, it may never have time to recover from the exposure before a new exposure will come. Such a situation can occur on a wet south facing wood panel that each sunny day is heated to such high temperatures that a rot fungi is inactivated. It

will therefore not have any growth and die. Such phenomena have also been seen for less severe exposures. This is not covered by the above discussed modelling, and will have to be considered separately.

Although the main aim of the present project is to develop methods and deliver data on fungal activity as function of environmental parameters, we also plan to do at least some simple simulations later.

4.0 Biological calorimetry

Isothermal Calorimetry is used in this project to measure the thermal power produced by the fungal samples. We take the thermal power as a measure of the activity of the fungi. The general idea is to make calorimetric measurements while changing environmental parameters, thus mapping the activity of the fungi as function of the environmental parameters (most importantly water activity and temperature). The methods applied in this project are discussed in this chapter.

4.1 Energy – heat – life

Nearly all processes (chemical, physical and biological) produce heat. Heat is a form of energy that always accompanies life processes.

The reactions by which organic carbon sources are broken down are used to obtain energy to support life. All biological processes are accompanied by production of heat and all metabolism is exothermic, i.e. produces heat, and this heat is continuously released to the surroundings. In a system with constant pressure (as is the case for most biological systems) the release of heat can be directly related to the change in enthalpy (ΔH).

According to the first law of thermodynamics, the conservation of energy, energy can neither be created nor be destroyed. It only can be transferred and converted between different types of energy. The lowest form of energy is heat. All other types of energy are called work and can be converted to heat.

Most organisms rely on aerobic metabolism (respiration) to obtain energy for sustaining activities and life. Respiration is essentially a combustion producing water and CO_2 , as was discovered by Lavoisier and Laplace in 1780 (Lavoisier and Laplace 1783). It has been known that since year 1917 that the enthalpy change during the combustion of most organic substances is directly proportional to the number of atoms of O_2 consumed during combustion ($\Delta_c H^0 = -465 \text{ kJ/mol O}_2$). This is called 'Thornton's law' (Thornton 1917; Battley 1987; Battley 1999).

The most basic aerobic metabolism is glucose degradation (Battley 1999):



For every mol of O_2 consumed for this aerobic reaction, about 469 kJ heat is produced and this value because of Thornton's rule, will be quite the same for other substrates than glucose (the exact value of the enthalpy also depends on other factors such as whether the produced CO_2 ends up dissolved in water or in the gas phase). All organisms (humans, mammals, invertebrates, fungi etc.) follow the above equation when they are doing complete aerobic metabolism. This rule therefore establishes a general connection between respiration and heat production. The heat production rate is proportional to metabolic rates and provides a direct indication of metabolic responses such as reaction to stresses.

4.2 Isothermal calorimetry

The measurement of heat and heat production rate is called calorimetry. Calorimetry has a long history in biology as Lavoisier and Laplace measured the heat production of a guinea pig already in 1780 (Lavoisier and Laplace 1783). During the last century a large number of different calorimetric techniques have been used in the biological field, mainly on microbiological systems. There are different types of calorimeters (Haines et al. 1998; Kemp 1998):

- Temperature scanning calorimeters (Differential Scanning Calorimeters, DSC) used for the measurement of heat capacities, phase changes etc.
- Bomb calorimeters in which a sample is totally combusted in O₂ to yield heats of formation.
- Adiabatic calorimeters in which the temperature changes in perfectly insulated samples are measured (in semi-adiabatic calorimeters some heat loss is allowed and corrected for).
- Isothermal (heat conduction) calorimeters that measure the thermal power from samples under essentially isothermal conditions. This is the type of calorimeters used in the present study. Sensitive such calorimeters are called microcalorimeters and are capable of measuring thermal powers in the order of 1 μW.

The isothermal calorimeter (often called conduction or heat conduction calorimeter) works by conducting the heat produced in a sample away from the sample, through a heat flow sensor, to a heat sink. The heat flow sensor is normally a thermopile consisting of about 100 semi-conductor thermocouples. An identical calorimeter with an inert sample is used as a reference to reduce noise (twin calorimeter). The reference is normally water with the same heat capacity as the sample. The calorimeter is placed in a thermostat to keep it at constant temperature. Fig. 18 shows a schematic drawing of an isothermal calorimeter and a typical output from a measurement.

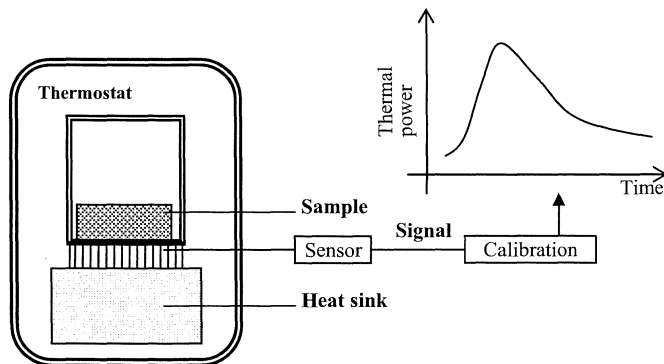

Figure 18: Schematic principle of an isothermal calorimeter

As heat is produced by the sample, the sample gets slightly warmer than the heat sink, and heat then flows through the heat sensor. A voltage is then created by temperature difference over the flow sensors. This signal is amplified and measured by a data logger connected to a computer. The signals (in volts) are converted to thermal power values (in watts) by multiplication with a calibration coefficient (in watts per volts) that is measured by electrical calibration.

There are two types of isothermal calorimeters used in this project:

- The TAM isothermal microcalorimeter (Thermometric, Järfälla, Sweden). With a liquid thermostat with a 24 h temperature stability of 0.1 mK, this calorimeter is very sensitive. It can measure the thermal activity with sensitivity of less than 1 μ W. There are four twin calorimeters in the TAM. The sample is placed in 3 ml ampoules of glass or stainless steel.
- The TAM Air isothermal calorimeter (Thermometric AB, Järfälla, Sweden). This isothermal heat conduction instrument contains eight twin calorimeters placed in an air thermostat with a 24 h temperature stability of 0.02 K. The samples are placed in 20 ml glass ampoules that are sealed with Teflon coated rubber seals and aluminium caps. This calorimeter is less sensitive than the TAM microcalorimeter. It can measure the thermal power with sensitivity of about 10 μ W, which is enough for many practical applications, e.g., in biology. This instrument has the advantage of low cost per calorimetric channel and very easy operation.

4.3 Biological calorimetry

Isothermal calorimetry is a direct method to measure the heat produced by metabolic activity. It is also a general analytical tool to monitor biological processes. Isothermal calorimetry is a non-destructive technique and it is therefore possible to repeat measurements on a sample, e.g., before and after different exposures or treatments to study biological responses. Contrary to many other techniques used to study biological systems isothermal calorimetry measures continuously, minute by minute, the activity of, e.g., a biological sample.

Calorimeters have been applied in the study of different biological systems (references given are examples).

- Applied studies in biochemical engineering (Duboc et al. 1999)
- Fundamental studies of yeast metabolism (Larsson and Gustafsson 1999)
- Aquatic animals, such as fish and insects (Lamprecht and Schmolz 1999)
- Animal physiology and bioenergetics (Hand 1999)
- Animal tissues (Kemp and Guan 1999)
- Human cells (Monti 1999)
- Plant metabolism (Criddle et al. 1988; Criddle et al. 1991a; Hansen et al. 1995; Criddle and Hansen 1999)
- Vegetable respiration (Gomez et al. 2004; Wadsö et al. 2004a)
- Microbial degradation of food stuffs (Shiraldi et al. 1999)
- Mould and rot fungi (Wadsö 1996; Wadsö 1997; Xie et al. 1997; Wadsö et al. 2004b)

Good sources of examples of biocalorimetric investigations are proceedings published after the conferences of The International Society of Biological Calorimetry².

4.4 Calorespirometry

Calorespirometry is the combination of calorimetry (measurements of heat) and respirometry (measurements of gas exchange, i.e., rate of O₂ uptake and/or CO₂ production). The connection between calorimetry and respirometry is that the complete combustion of almost any organic compound produced a heat of about 465 kJ per mol O₂ consumed (Thornton 1917). This together with the assumption that the respiratory quotient (RQ, mol CO₂ produced per mol O₂ consumed) is 1.0 is the basis of indirect calorimetry in which one measures gas exchange and calculates heat production. However, the model is only valid for steady-state systems, i.e., systems that are mature and not changing in any way. Hansen et al. believes that this is seldom the case and that most applications of indirect calorimetry actually have been made on non-steady state systems and therefore more or less incorrect (Hansen et al. 2004).

When the situation is not as simple as Thornton's rule suggests, calorimetry and respirometry do not give the same result. In many cases these two techniques can therefore not replace each other, but rather complement each other. There are two reasons for this. Firstly, the respiratory quotient is not always one. With different biological substrate, RQ varies from 1 to 0.72 (carbohydrates: RQ=1, proteins: RQ=0.84, lipids: RQ=0.72) (Kleiber 1961; Gnaiger and Forstner 1983). When the substrate is mixed or unknown, the RQ is also unknown. Secondly, Thornton's rule can not be applied to any other metabolism than fully aerobic respiration. Under anaerobic conditions no O₂ is consumed and such metabolism produces much lower amounts of heat for every mol of carbohydrate consumed (or CO₂ produced). It has been shown that different systems thought of as aerobic, for example human cells, also can have an anaerobic component (Gnaiger and Kemp 1990).

The term calorespirometry was coined by Gnaiger (Gnaiger et al. 1989). He and others used different combinations of calorimetry and liquid phase O₂ and CO₂ electrodes to study biological processes in the liquid phase (bacteria, yeast, mammalian cells, human cells etc.). Another principle was pioneered by Hansen, Criddle and co-workers who combined classical Warburg respirometry with calorimetry to study biological samples in the gas phase (the biochemical processes inside the samples of course still run in a liquid environment). They have studied biological samples such as tomato tissue, corn meristem, lichens, insects and tree shoots (Criddle et al. 1988; Criddle et al. 1991a; Macfarlane et al. 2002). Combined calorimetry and respirometry has also been performed in larger scale whole-body calorimeters (i.e. (Atwater and Rosa 1899)) and in bioreactor calorimeters (Duboc et al. 1999).

Enthalpy balance models

Respirometry, the measurement of exchange rates of O₂ and/or CO₂, is a common technique in biology. Although gas exchange rates are of primary interest in many

² The International Society of Biological Calorimetry URL: www.biocalorimetry.org

applied cases, for example when possible O₂ depletion is investigated, Kemp, Gnaiger, Hansen and others have stressed that the understanding of the biochemical pathways is greatly increased if a third parameter also is measured: the heat production rate. These three measured parameters are the most frequent used in the scientific field of bioenergetics. Here a short summary is given of some more complex models, essentially following Hansen et al. (Hansen et al. 2004).

Metabolic processes are frequently divided into catabolic and anabolic processes. Catabolic processes oxidize substrates to CO₂, water and energy that is used to drive the anabolic processes of building new organic compounds. Related to these terms are the terms maintenance and growth, but it is difficult or impossible to actually separate maintenance and growth (but the terms are useful as conceptual terms).

Thermal power (heat production rate) P (W) can in general be seen as the product of an enthalpy change ΔH (J/mol) and a rate v (mol/s). For biological processes composed of many part processes this can be formulated as an enthalpy balance model:

$$P = \sum v_i \Delta H_i \quad (8)$$

This is a parallel to a mass balance model. Fortunately we do not need to take into account all part processes, but can write a simplified overall model for steady-state respiration like (cf. Eq. 8 above):

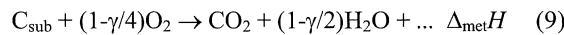

Here, C_{sub} is the carbon substrate and γ is the oxidation number of carbon in the substrate. From this we can calculate a relation between the O₂ consumption rate v_o and the CO₂ production rate v_c :

$$v_c = v_o \left(1 - \frac{\gamma}{4}\right) \quad (10)$$

We can also use the above model to find if a system is partially anaerobic (or doing anaerobic metabolism even if it is not anoxic).

A model that takes into account growth can be constructed from the following more complete chemical equation:



Here C_{bio} is the new biomass and ε is a substrate carbon conversion efficiency. By assuming substrate nitrogen to be fully reduced and neglecting P, K etc. (that do not contribute significantly to the overall energy balance) it is possible to write equations relating the gas exchange and heat rates as functions of the substrate and biomass oxidation states. For a further discussion of this, see Hansen et al. (Hansen et al. 2004).

Models like the ones discussed above can be used to:

- To find out more about the overall biochemical processes of a sample, for example if it is doing anaerobic metabolism or not (Gnaiger and Kemp 1990).
- As a tool to find plants etc. of superior growth efficiency (Hansen et al. 1998).
- In the study of organism adaptation (Macfarlane et al. 2002).

As calorimetric measurements are rather simple and can be combined with respirometry the combination of measurements of the rates of O₂ consumption, CO₂ production, and heat production is a practical method of finding out more about overall biochemical processes.

5.0 Calorimetric studies in this work

The applied work for this project can be divided to four phases. The first phase is to test and validate the instruments and methods. The second phase is to measure the fungi activity on nutrition rich media, such as malt extract agar, to test the application of the methods measurement on fungi. The third phase is to measure the fungal activity on real (nutrient poor) substrates, i.e. building materials such as wood and gypsum board. The fourth phase it to collect the information from measurement to establish a model. The first two phases have been done and are presented in this thesis. Phase 3 and 4 will be in focus for the second half of the project.

5.1 Calorespirometric method

The calorespirometric method developed for this project is based on a design by Hansen, Criddle and co-workers (Criddle et al. 1991b). Their method had been used to assess respiratory quotients, heat production rates and gas exchange rates at steady-state (usually atmospheric) conditions, mainly on plant material, but also on lichens, insets etc. An advantage with their method over other calorespirometric methods is that it only requires a calorimeter and a pressure sensor. The aim of our development of their method was a method that could follow the respiration of a sample being exposed to unsteady-state decreasing O_2 pressure and increasing CO_2 pressure, and also to anoxic conditions.

The calorespirometric device (shown in Fig. 19) consists of two isothermal calorimeters placed in a TAM Air thermostat (Thermometric AB, Järfalla, Sweden). The calorimeters are modified TAM Air calorimetric units (Wadsö 2003). Two 20 ml glass ampoules are placed in the calorimeters and are connected by a tube. The sample is placed in one of the ampoules and a CO_2 absorbent is placed in the other. On the tube there is a valve, which is controlled by a motor from outside of the thermostat. Each ampoule is connected to an external pressure sensor by a thin stainless steel tube.

Aqueous NaOH (0.4 M) was used as CO_2 absorbent solution, as in the works by Hansen, Criddle and co-workers (Criddle et al. 1990; Criddle et al. 1991b; Fontana et al. 1995). This solution has a water activity close to 1.0. Therefore it has the same water activity as many biological samples, such as plant tissue and the high water activity agars we have been working with. If the water activities of the absorbent solution and the sample are different significant thermal powers will also come from the evaporation-condensation of water as water vapor diffuses from the higher to the lower water activity. For measurements of samples at lower water activities other hydroxide solutions are needed. Some preliminary experiments have been made with absorbent with different water activities by mixed aqueous solutions of LiOH (0.4 M, CO_2 absorbent) and LiCl (0-8.0 M, regulate water activity). The water activities of the solutions were measured with RH sensor and the results are in Fig. 20. Some titration measurements were done to determine the reaction enthalpy (needed in the evaluation) of CO_2 and such solutions. Results were in the range 100 ± 5 kJ/mol CO_2 , but the results are uncertain as calorimetric gas-liquid titration is difficult to perform.

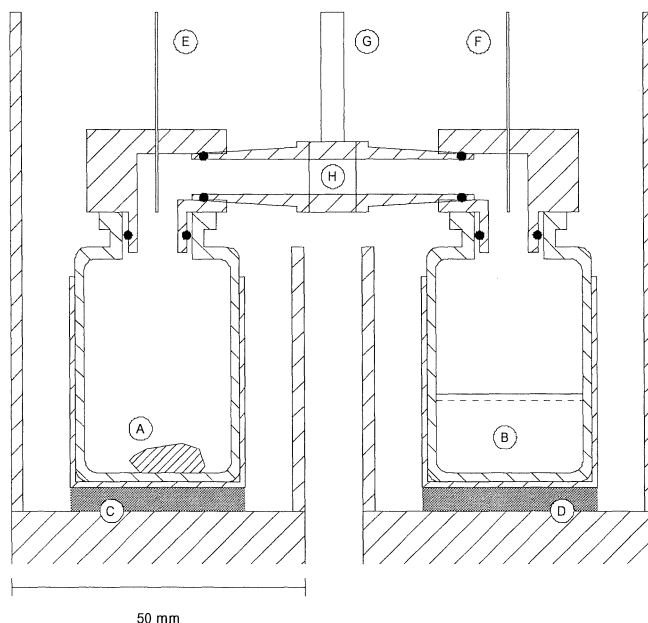

Figure 19: A schematic drawing of the caloresspirometric device presented in the paper. A. Sample. B. CO₂ absorbent solution. C. Sample calorimeter heat flow sensor. D. Absorbent solution calorimeter heat flow sensor. E. Sample ampoule pressure sensor tube. F. Absorbent ampoule pressure sensor tube. G. Shaft to turn valve. H. Valve. Note that the drawing does not show the bottom parts of the heat sinks or the top part of the instrument with pressure sensors and valve operation. The instrument is placed in a thermostat

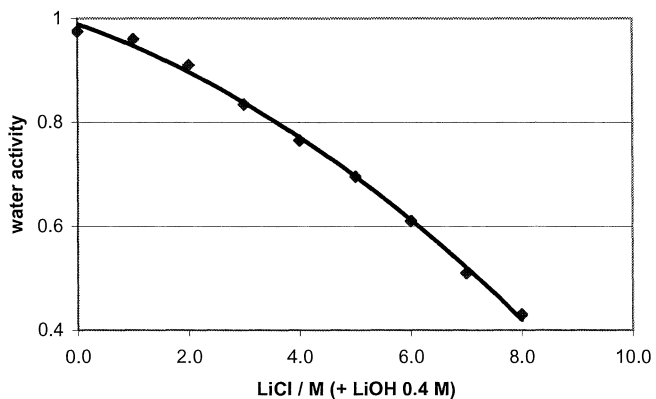

Figure 20: Water activities of aqueous solutions of LiOH (0.4 M) and LiCl (0-8.0 M), measured with a capacitive relative humidity sensor

Our instrument works by a similar principle as the instrument described by Criddle and coworkers (Criddle et al. 1991b), except for the valve that we have introduced between the ampoules. While Criddle and coworkers only ran short term measurements designed to capture the respiration at essentially atmospheric conditions, we use the instrument for long term measurements under which we have considerable changes in CO₂ and O₂ pressures.

Humidified air is pumped through the sample before the measurement start to ensure that the measurements start with normal air composition. During a measurement the thermal powers of the sample and the absorbent, and the pressure in each ampoule are recorded continuously. During a measurement the valve is opened and closed at regular intervals by a step-motor. The disturbance from switching is small and can be neglected. A measurement starts at aerobic conditions and can continue until all O₂ is consumed. It thus provides data of a biological sample's reaction to changing CO₂ and O₂ pressures.

5.1.1 Calorespirometric measurement on *Serpula lacrymans* (not previously published)

The rot fungus *Serpula lacrymans* (isolated from a house in Oslo, Norway, strain SL 1 from Haavard Kausrud at Oslo University) was inoculated on 5 ml malt extract agar media, MEA (Merck, Germany) in 20 ml glass ampoules 2 weeks before the calorimetric measurements started. The absorbent was 5 ml aqueous 0.4 M NaOH.

The valve was repeatedly closed and opened every one hour during the measurement. After 7 full cycles (15 hours) of measurement, the valve was kept closed until the thermal power went down to baseline values. Then the valve was opened again – to let the O₂ remaining in the absorbent ampoule diffuse to the fungus - and kept open until the thermal power of the sample once more decreased to zero. The result of the *S. lacrymans* measurement is shown as in Fig. 21.

At the time this measurement was done we did not have the evaluation model presented in paper I. We therefore made an evaluation by simulating the measurement with different models of the fungal sample's response to changing gas composition. The diffusion of the gases leads to a time lag between the CO₂ production and the CO₂ absorption. As the geometry of the system is known and the gas transport is by diffusion, the gas flow in ampoules can be simulated, based on the geometry of the calorespirometric device, the properties of gas diffusion. Different models of the sample's response to changing environmental conditions were tested and the one that gives a result that is closest to the measured result is a candidate for a model of the sample.

Input data to the program was a model of the biological sample and the valve program. Output was the four measured parameters (thermal power of sample and reference, and pressure at sample and reference) as a function of time. It is also possible to check other parameters of interest, e.g., the CO₂ pressure at the sample.

The simulation program was made by dividing the gas phase of the instrument into four parts and calculating the diffusion (and resulting convection) of N₂, O₂ and CO₂, with an explicit difference method (it was assumed that there were no water vapor

gradients in the system). As the model was rather rough the behavior of the model was improved by adjusting the conductances to give a good fit to the result of a simple experiment without any sample, in which the valve was opened when there were CO₂ on the sample side, but no CO₂ on the absorbent side. In one end of the model the sample consumes O₂ and produces CO₂ according to the model of the biological sample, and at the other end CO₂ is consumed by the absorbent. During a simulation the connection between the two central parts of the model switched from no transport when the valve is closed, to normal diffusion when the valve is open. The simulation program was written in MATLAB 6 (The Mathworks, Natick MA, USA).

One rationale for developing the simulation model is that it is otherwise difficult to visualize the dynamic changes of gas concentrations at the sample. Depending on the geometry of the instrument, the CO₂ production rate of the sample, and the valve cycle times, the CO₂ concentration at the sample can change from low to high values, or remain essentially constant. During the measurement presented in this paper the simulation shows that the CO₂ does not drop to zero during the open cycles. This is because the diffusional flow path is rather long in the present instrument. However, it is difficult to make it much shorter as it connects two calorimeters that must be separated to decrease thermal cross-talk.

The model of the biological system used was a black box model of the thermal power produced by the sample P_s , the respiration quotient RQ (mol(CO₂)/mol(O₂)) and the enthalpy of respiration $\Delta_s H$ as functions of CO₂ and O₂ pressures. For the present test measurement on a sample of the dry rot fungus *S. lacrymans* we got satisfactory results with the following model (in the present model the effects of CO₂ and O₂ are separated and given as f_C and f_O in Fig. 22):

$$\begin{aligned} P_s &= f_C(p_{CO_2}) \cdot f_O(p_{O_2}) \cdot P_0 \\ \text{RQ} &= 1.25 \\ \Delta_s H &= 467 \text{ kJ/mol(CO}_2\text{)}, \end{aligned} \tag{12}$$

Here, P_0 is the thermal power of the sample at atmospheric conditions, i.e. at the start of the measurement. It should be noted that P_0 includes the effect of biomass, nutritional status etc. In the present experiment we are studying relative changes when environmental parameters change. The factors f_C and f_O model how the sample reacts to CO₂ and O₂ pressures. Figure 22 shows how f_C and f_O that gave the best fit depended on CO₂ and O₂ pressures, respectively, and Figs. 23 and 24 gives the corresponding simulation result.

During the first 15 hours, the pressure of O₂ kept decreasing as O₂ was consumed by the sample. The pressure of CO₂ oscillated around 2000 Pa. In the same time, the thermal activities of the sample were quite constant. However, note that the experimental sample thermal power shows a slight oscillation, probably an effect of the changing CO₂ pressure. During hours 15 to 20, when the valve was closed, the concentration of CO₂ was increasing. At the same time, a slight decline of sample thermal activities was measured. During hours 20 to 23, when CO₂ reached a level of about 11000 Pa, while the concentration of O₂ declined to below 2000 Pa, a dramatic decline of sample activity was measured. After O₂ was finished in sample ampoule, no sample activity was measured (hours 23 till 25). There was also no pressure change observed in the sample ampoule.

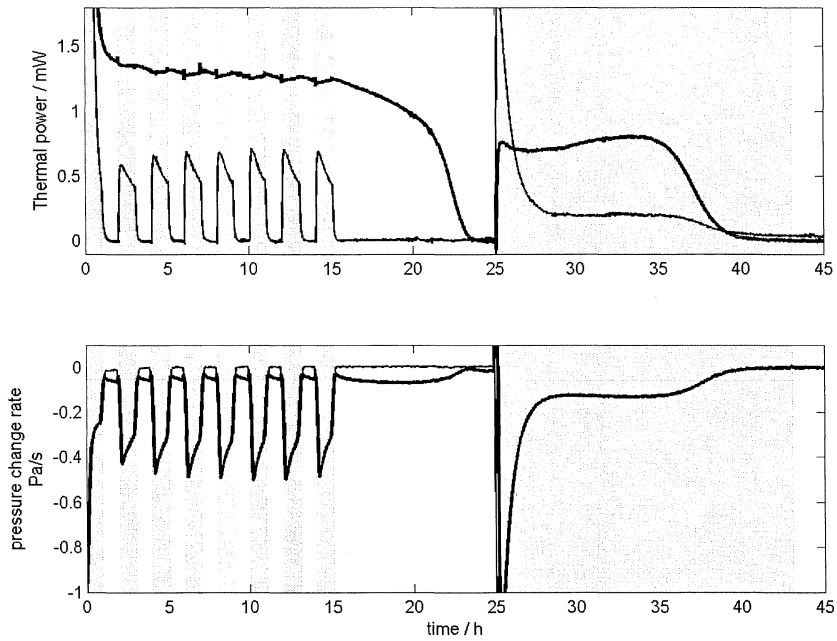

Figure 21: Result of a test measurement with the dry rot fungi *Serpula lacrymans* growing on MEA agar. The measurement lasted for more than 50 hours. From aerobic condition till O_2 is finished in both ampoules. There is neither thermal activity nor pressure increase detected in anoxic environment while the valve is closed (no contact to the CO_2 absorbent). The grey fields show when the valve is open. The thick lines are for the sample and the thin lines are for the absorbent

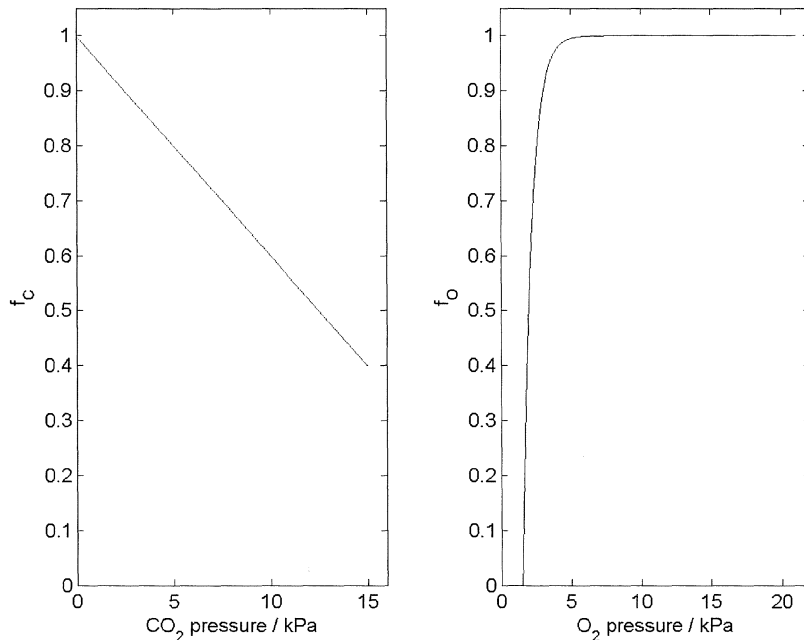

Figure 22: Factors f_C and f_O used for simulation of *S. lacrymans* behavior. The factors f_C and f_O take into account the influence of CO_2 and O_2 pressure on the activity of a sample

There are two aspects of the experimental result that the simulation has not been able to capture:

- During the first hours of the simulation there is a much slower increase in CO_2 absorption rate than in the sample results. This may have been caused by the initial conditions of the sample not being modeled correctly, or that the initial part of the measurement was disturbed by the charging of the ampoules.
- When the valve was opened again at hour 25, the activity of sample only recovered to about 60% of the level it had had before. We believe that this is the result of part of the sample not surviving the anoxic conditions. We have seen in other measurements with *S. lacrymans* that the longer the anoxic conditions last, the higher is the loss in thermal power afterwards. Similar effects of anoxic conditions on viability have been demonstrated for other decay fungi by Scheffer (Scheffer 1986). He concluded that decay fungi were moderately retarded by an O_2 pressure of 1150 Pa and severely retarded at around 270 Pa.

The results from the experiment indicate that *S. lacrymans* is rather insensitive to O_2 pressure, as long as it is above about 3000 Pa. When O_2 concentration is below the critical level, the activities declined quickly. Increased CO_2 pressure seems to decrease the level of thermal power.

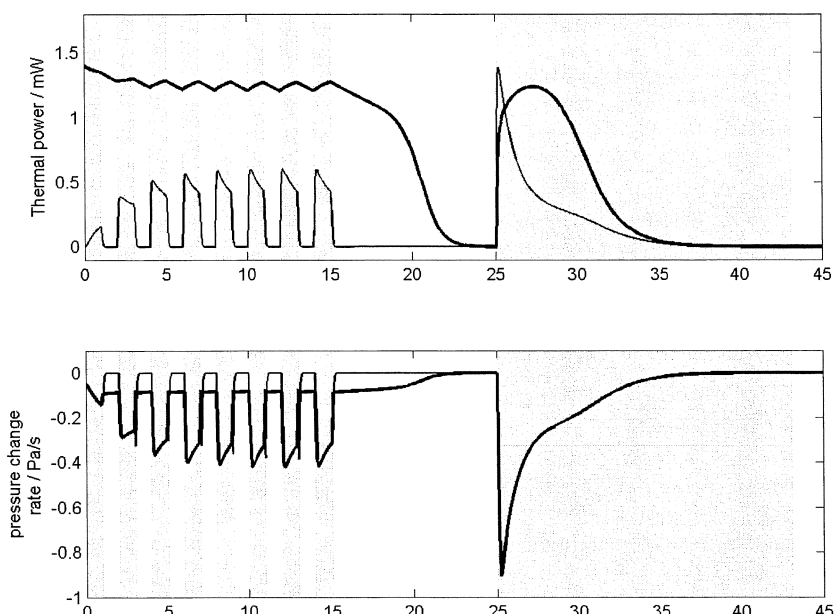

Figure 23: Simulated result showing the same curves as Fig. 21. The grey fields show when the valve is open. The thick lines are for the sample and the thin lines are for the absorbent

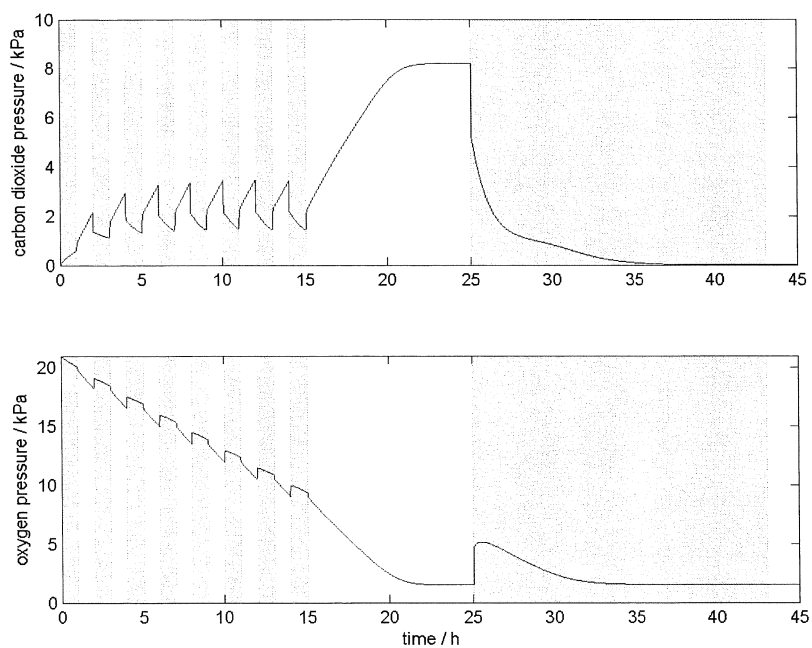

Figure 24: Simulated CO₂ and O₂ pressures

5.1.2 Calorespirometric measurement on two mould fungi (Paper I)

Two mould fungi *Penicillium roqueforti*, and *P. camamberti* were inoculated on 10 ml malt extract agar (Merck, Germany) in 20 ml glass ampoules 7 days before the measurements. The absorbent was 10 ml aqueous 0.4 M NaOH. The evaluation procedure used was based on averaging over full valve cycles. It was rather successful, but it is essentially a steady-state model applied on an un-steady state case and we do not know its actual limitations. With a more complete model of the gas diffusion within the device it would be possible to make a more detailed analysis within each cycle. This would probably involve a rather complex evaluation method and has not been attempted within this project. Details and results of the measurement are discussed in paper I.

5.2 Correlating calorimetry and ergosterol quantification (Paper II)

There are no published correlations between calorimetric techniques to study fungi and any other methods. We have therefore started one such study by correlating heat production with ergosterol content. The first results of this study are presented in the draft paper II.

Calorimetry is a very general method that can be used on almost all physical, chemical and biological systems. Ergosterol quantification is a very specific method that measures the ergosterol content in fungi as a measure of fungal biomass. Ergosterol is a unique fungal sterol exists in fungal membrane. Measurement of ergosterol content is an established method in the field of fungal research.

5.2.1 Method

Serpula lacrymans was inoculated to thirty 20 ml glass ampoules with 2ml 2% malt extract agar (Merck, Germany) with hydrophobic cotton as air filter. The samples were placed in a high humidity environment (RH>97%) for cultivation. An ampoule with 2 ml MEA and cotton filter but without fungus is used as a blank. The thermal activity of the sample was measured about every 2 days for about 90 minutes in a TAM air calorimeter. After every batch of calorimetric measurements, randomly picked samples were taken out of the experiment and kept in low temperature freezer (-50°C) for later ergosterol measurement by GC-MSMS at Department of Medical Microbiology, Lund University. The study is described in paper II in some detail. Below are given some results, most of which are not given in the paper:

5.2.2 Results

Visual growth

Growth of *S. lacrymans* was observed visually on the third day after inoculation. The colonies then gradually grew from the centre and covered the whole agar surface after at about 10 days.

Calorimetric measurement

The first calorimetric measurements were made just after inoculation, but it was only after about 3 days that measurable thermal powers were measured. Results from three samples that were measured for long time are shown in Figs. 25-27. The measurements during the first days showed endothermic values (negative thermal powers) values increasing to zero within two days for all samples (also for the blank sample). We believe this to be heat from the agar itself (or possibly the evaporation of water from agar). In Figs. 25-27 the result from the blank has been subtracted from the results of the fungal samples. Still the results from the first days of measurement should be viewed with some caution.

The growth on the agar can from these results be divided into four phases:

Initial phase: The first 2-4 days when the new inoculums adjust to the new environment. There was no change in the appearance of the inoculums. Their thermal activities were low and have relatively large spread (discussed above).

Accelerating period: From about day 4, fungal growth was both seen visually and measured by the calorimeter. The thermal activity then increased rather linearly (maybe slightly “exponentially”) for about 10 days. This corresponds to a situation where there is still uncovered agar surface and plenty of nutrients. It is a parallel to the exponential growth seen in liquid cultures of microorganisms, but as the growth is restricted to the 2-dimensional surface it has to be modelled in somewhat different fashion. If we assume that there is a constant increase in colony radius r (m) on the surface and that the thermal power P (W) is proportional to the area of the colony, we get the following equations (the k 's are constants):

$$\frac{dr}{dt} = k_1 \quad (13)$$

$$P = k_2 \pi r^2 \quad (14)$$

Solving these two equations gives the following second order relation for thermal power as a function of time:

$$P = k_3 t^2 \quad (15)$$

As there certainly is higher activity at the growth front than in the rest of the colony, it is also reasonable to test the assumption that the thermal power is proportional to the circumference of the colony:

$$P = k_4 2\pi r \quad (16)$$

This gives the following linear relation for thermal power as a function of time:

$$P = k_5 t \quad (17)$$

A model taking into account both heat from the whole mycelium (“maintenance”) and the higher activity in the front (“growth”) is a linear combination of the above two results (the c ’s are constants):

$$P = c_1t + c_2t^2 \quad (18)$$

Although the results seen in Figs. 25-27 contains too few data points (especially at days 5-7) for a rigorous test of the above model, it can be seen that the thermal power during the accelerating phase is essentially linear, possibly with a tendency for a superimposed quadratic term.

Stationary period: When the fungal colony reaches the end of the agar the thermal powers are rather constant. The supply of nutrients probably also decreases at this stage. This period lasted for about 2-7 days.

Declining period: The visual size of the fungal colonies remained constant. Some of the colonies looked drier by the end of the measurement. The thermal activities started decreasing. The amount of nutrition in the agar is limited and after about 12-22 days the activities of fungi started going down.

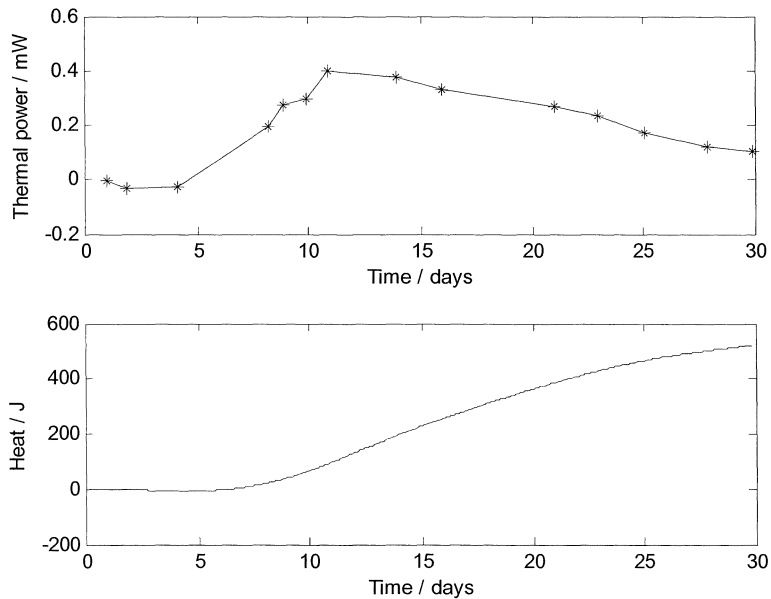

Figure 25: *S. lacrymans* (sample No. 3) thermal activities on MEA and the total heat production calculated by integrating the linearly interpolated top curve

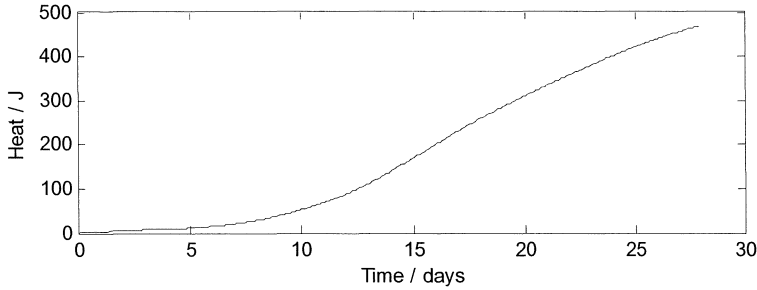
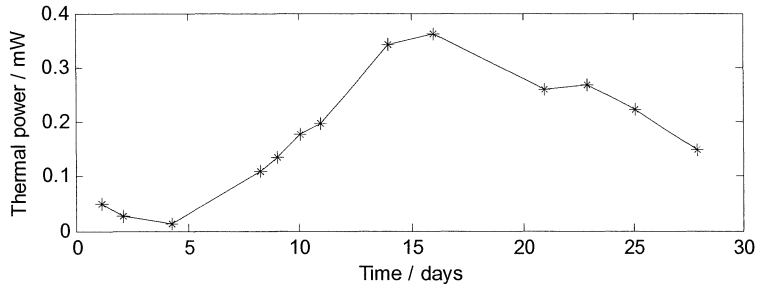

Figure 26: *S. lacrymans* (sample No. 15) thermal activities on MEA and the total heat production calculated by integrating the linearly interpolated top curve

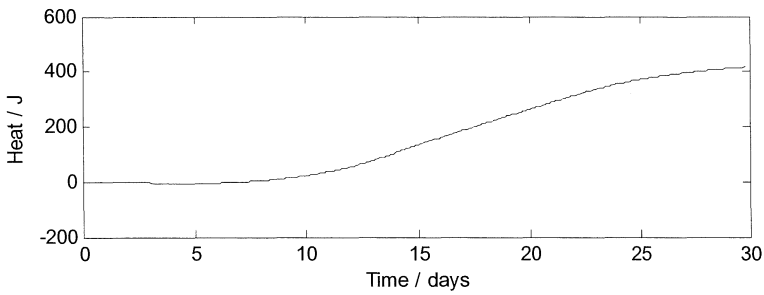
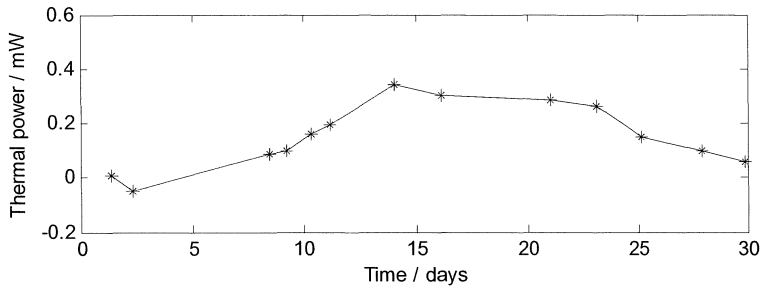

Figure 27: *S. lacrymans* (sample No. 31) thermal activities on MEA and the total heat production calculated by integrating the linearly interpolated top curve

The total heat produced by each sample was calculated by integrating the linearly interpolated measured data for each sample (from inoculation until the samples were removed from the calorimetric measurements and frozen). These data are drawn as a function of time (freezing of sample) in Fig. 28. It is seen that all samples showed quite similar trend.

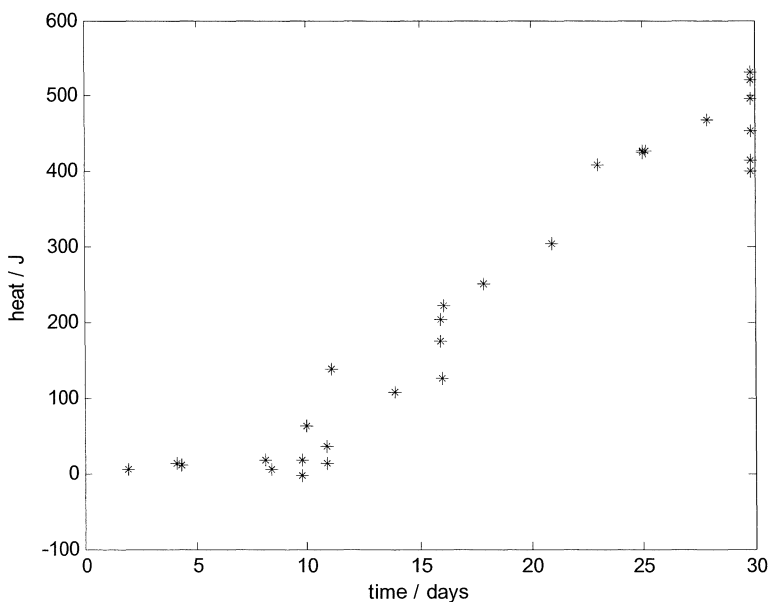

Figure 28: *S. lacrymans* total heat production

Calorimetry measurement and ergosterol content

The total heat production and the ergosterol content of *S. lacrymans* samples are compared showed a rather linear correlation (Fig. 29). About 8 μg of ergosterol seems to be related to zero heat production. This may be ergosterol initially present in the inoculums or the result of not so good calorimetric measurements during the first days. However, the result clearly indicates that there is a correlation between activity as measured by calorimetry and biomass as measured by ergosterol quantification. We will continue this study using other fungi and other substrates.

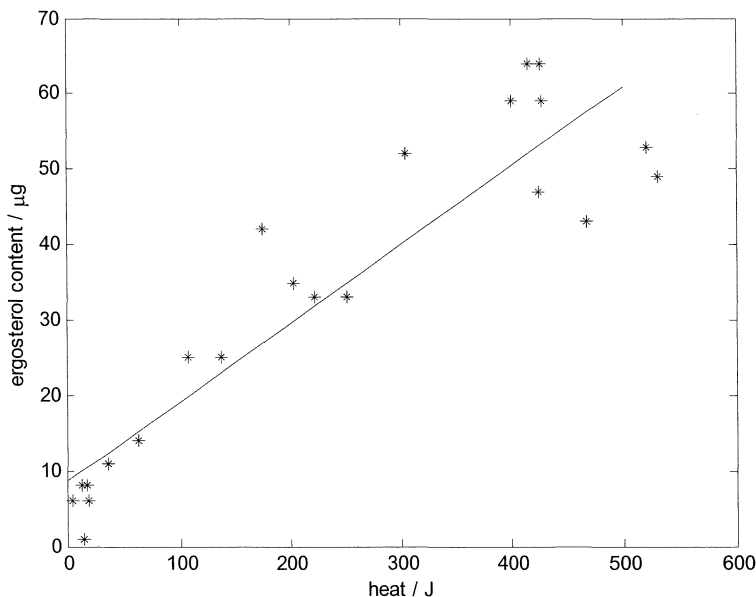

Figure 29: *S. lacrymans* ergosterol content as function of heat produced

5.3 Calorimetric measurement of fungi on real substrate

The growth of mould samples on real substrates, such as wood, is different to the growth on agar media, mainly because substrates in buildings are much poorer in nutrients than agars. Therefore, it is important to use real substrates and control their water activities.

The substrates on which fungi normally grow in buildings, such as wood and gypsum boards, are very hygroscopic materials. Changing water activity of even a small amount of such a hygroscopic sample can be problematic, e.g., in a calorimetric equipment as it requires relatively large volumes of humidified air to pass the sample to bring it to a new water activity.

There are several methods to change the water activity through the gas phase. Firstly, one can place the sample in a container with a constant relative humidity source, for example saturated salt solutions. The substrate will eventually reach the water activity of the relative humidity source, but this can take long time, as the diffusion rate of water vapour in air is quite limited. Secondly, humidified gas can be flowed through a vessel containing the sample. In this way, the air diffusion in the gas phase is not the limiting factor as the gas flow will deliver the humidity close to the sample. Thirdly, the water activities can also be changed by adding liquid water. However, this is not often used to change the water activity of substrates with fungal growth, because the liquid will most likely disturb the fungi. Adding water has only been used to modify

the substrate's water content (and therefore also its water activity) before the substrate is inoculated with the fungi.

For microcalorimeters there are perfusion devices available with perfusion rate about 100 ml/h as higher flow rates will disturb a measurement. Using such a device it would take about 100 hours to change the water activity of a 200 mg wood sample from 0.7 to 0.795 in a 0.8 water activity gas stream (Wadsö 1997). The long time is the result of the low flow rate and that air cannot hold much water vapour. If the flow rate is 5000 ml/h, it takes 2 hours to make the water activity change discussed above. Therefore, in order to study the thermal activity of fungi on hygroscopic substrates within a reasonable time, a humidity generator with higher perfusion rate than is normally used in microcalorimeters is required (Wadsö 1997). As it is not possible to have such high flow rates *within* a microcalorimeter, the humidification has to take place outside of the microcalorimeter.

5.3.1 Relative humidity modifier

A device to externally modify the relative humidity of microcalorimetric samples was developed by Wadsö is shown in Fig. 30 (Wadsö 1997).

The principle of the device is to create the desired relative humidity by mixing different proportions of air from two sources with different relative humidities. This is done by using a relatively high flow rate (5000 ml/h) to modify a sample's water activity within relatively short time (during which a sample's growth is not significant). A, B, C and D in Fig. 30 are four sealed 20 dm³ plastic boxes. A and B have their bottoms covered with saturated aqueous Mg(NO₃)₂ solutions, which regulate the relative humidity of the air to approximately 54% at 20°C. Boxes C and D contain saturated aqueous KNO₃ solutions to regulate the air humidity in those boxes to approximately 95% RH. Room air flows through the plastic boxes and reaches a timer controlled two-way valve E. This valve governs the mean relative humidity of the air stream by letting different proportions of air with the two relative humidities 54% and 95% be mixed and therefore provide relative humidity in the range from 54% to 95%. The humidity air continues to the sample (H) that is placed in the 3 ml calorimetric vessel (G) that can also be placed in the TAM microcalorimeter. The vessel is connected to the humidity generator through two tubes with Millipore filters (F) to prevent contamination. One of these tubes continues down to near the bottom of the vessel (Fig. 30); the other ends on the bottom side of the lid. The tubes are sealed when in the microcalorimeter to prevent evaporation from the sample. A peristaltic pump (J) draws air through the system which also contains a relative humidity sensor (I).

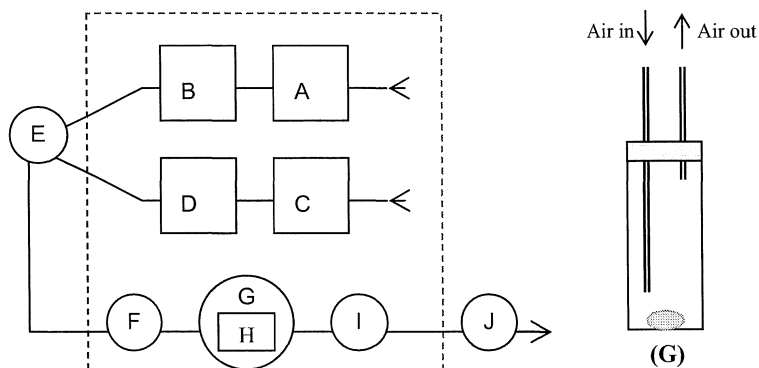

Figure 30: Schematic picture of the humidity generator. The dashed line shows the extent of the insulation (Wadsö 1997)

The humidity modifier is insulated and placed in a room with a controlled temperature of about 20°C. As a substrate of wood or any other material only shows small changes in water activity when the temperature is changed (within the growth temperature range of fungi) at constant moisture content, it is possible to use the 20°C sample humidifier also for samples that are measured at other temperatures in the calorimeters. However, it may disturb the fungi if they not only have their water activities changed, but are also exposed to cycles in temperature. We therefore plan to equip the humidity modifier with its own thermostat that can be held at the same temperature as the calorimeter.

5.3.2 Temperature modification

Measurements in the isothermal calorimeters can be made at different temperatures. Most such calorimeters covers the range in which fungi grow, possibly with the exception of temperatures close to 0°C as one then easily gets problems with condensation in the instruments.

If one is interested in how fungal samples adapt to (or recover from) changes in temperature two types of measurements can be done by changing the temperature of fungal samples in calorimetric studies. Firstly, the temperature of sample can be changed in the isothermal calorimeter that can be set at different temperatures. It can then be used to measure the fungal activities at different temperature. A typical use of this is to measure the activities of samples at, e.g., 20°C. Then the samples are either taken out of the calorimeter and placed at 20°C while the temperature of the calorimeter is changed to, e.g., 30°C (this takes 5-20 h), or kept in the calorimeter during the temperature change. When the samples are then placed in the calorimeter again they will be exposed to a jump in temperature and the measured thermal power (after the initial disturbance caused by the cold samples) will be a measure of the how well the fungi adapts to this sudden change in temperature.

Secondly, the temperature of the samples can be modified in an external heating block. With this method one can control the rate of heating etc. and be more flexible in what temperature programs one uses. The simplest type of experiment is to

measure the activity in the calorimeter at a certain temperature and then expose the sample externally, before bringing it back to the original temperature to measure it again in the calorimeter.

Note that the calorimeters that we are using are isothermal calorimeters, not scanning calorimeters. They can be used at different temperatures, but no measurements can be done while the temperature is being changed. There have been some investigations of thermal activity of biological samples using temperature scanning calorimeters (Hemming et al. 2000), but these have then been run in the “isothermal mode”; the scanning only used to go quickly between different temperature levels. The drawback with using scanning calorimeters is that they often have much lower specific sensitivity than isothermal calorimeters.

5.3.3 Measurements and Results

Results 1: Humidity generator calibration

The humidity sensors of the humidity generators were calibrated in known humidities controlled by different saturated salt solutions at 20°C (Nyqvist 1983). The relative humidity of the humidity generator was then validated with the humidity sensors. Table 3 gives the five saturated salt solutions used to provide relative humidities in the range of the instrument.

Table 3: Relative humidities of saturated salt solutions at 20°C

Aqueous salt solution	Relative humidity (RH)
NaBr:	59.5%
KI:	69.9%
NaCl:	75.5%
KCl:	85.1%
KNO ₃ :	99.6%

Relative humidity sensors were connected to the glass bottles, sealed and stabilized for 20 hours. The results of humidity sensors calibration is shown as a solid line in Fig. 31 and it is seen that there is a good agreement between the two measurements, indicating that the humidity generator works as expected. The relative humidity sensors were then connected to the humidity generator to test the humidified air generated. The results are shown as circles in Fig. 31.

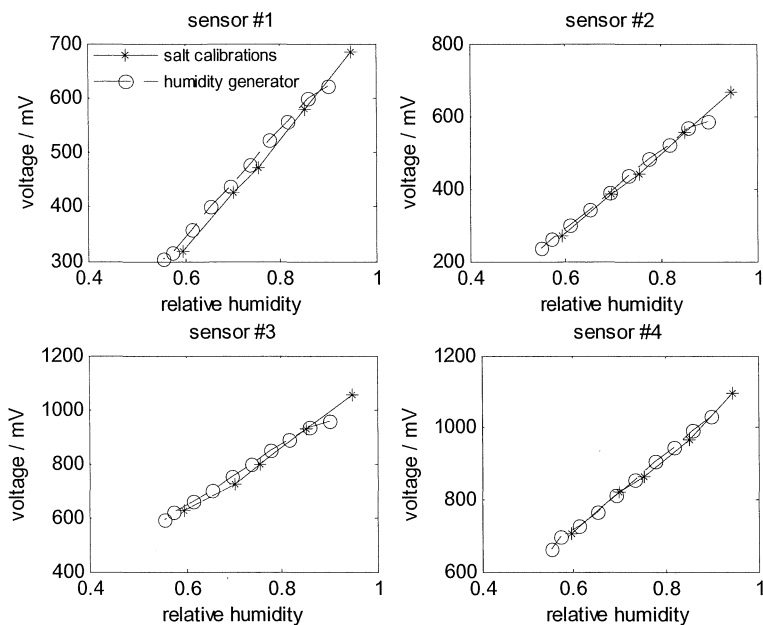
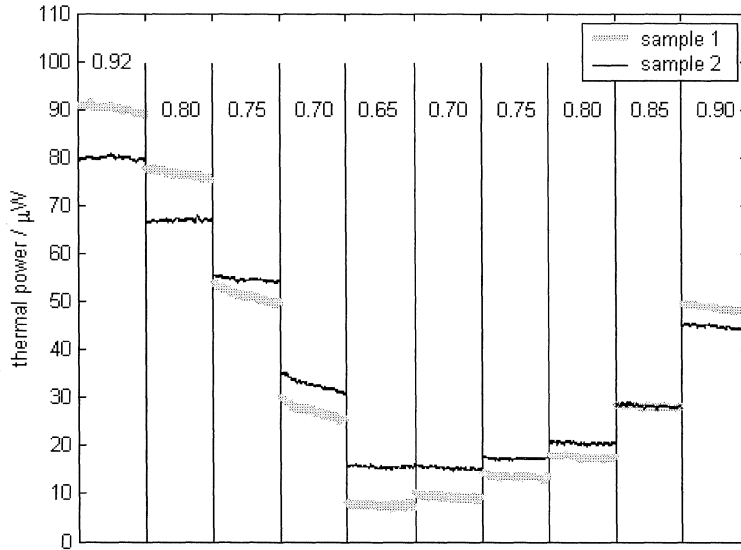

Figure 31: Calibration of humidity sensors and validation of the humidity generator

Results 2: Mould activity as a function of water activity

Two pieces of bread (1 g) with green mould growth was taken from a mouldy wheat tortilla bread. It was placed in the calorimetric vessels and connected to the humidity generator. Air with 92% relative humidity was pumped at speed of 5000 ml/h for about 2 hours through the sample vessels. Their water activities should then be modified till 0.92 according to calculations by Wadsö (Wadsö 1997). Then the thermal activities were measured in the microcalorimeter. Samples were then moved back to the humidity generator and their water activity was modified till 0.80 before again measuring their thermal activities in the calorimeter. This was repeated at water activities at 0.75 and 0.70. The thermal activities decreased with the decrease of water activities of the bread samples. When the water activities were at 0.65, the mould still kept their metabolism at about 10-20% of their maximum level.

The water activities of the mould samples were then increased stepwise from 0.65 to 0.70, 0.80, 0.85 and 0.92 while the thermal activities were measured. The results showed that the thermal activities of the bread samples increased with the increasing of their water activities. However, the thermal activities during absorption were lower than those during desorption. This result (shown in Fig. 32) is qualitatively similar to results by Wadsö (Wadsö 1997).



2-hour measurement for each water activity step

Figure 32: Thermal activities of bread mould at different water activities

In the first half of the measurement, the substrates experienced desorption: water activities decreased from high (0.92) to low (0.60). During the second half of the measurement the sample absorbed water vapour as water activities increased from low (0.60) to high (0.90). The fungal thermal activities changes to the corresponding desorption and adsorption changes are shown in Figs. 33-34. According to the nature of hydrophilic materials, the water contents of a substrate are different between desorption and adsorption stage (at same water activity). The water content is higher during desorption than during absorption. This might explain partly why the mould activities are lower in the second half of the measurement, and implies that biological activity is not only a function of water activity, but also of moisture content. A similar conclusion was reached by Labuza and co-workers for lipid oxidation in food-stuffs (Labuza et al. 1972). This is contrary to the present concept that water activity is the proper water quantity to use when investigating the relation between water state and reaction/growth rate (Scott 1957). It is probable that when looking at different samples (with different sorption properties) the water activity is the best parameter to use, but when looking at only one material the moisture content (hysteresis limb) is also of some importance.

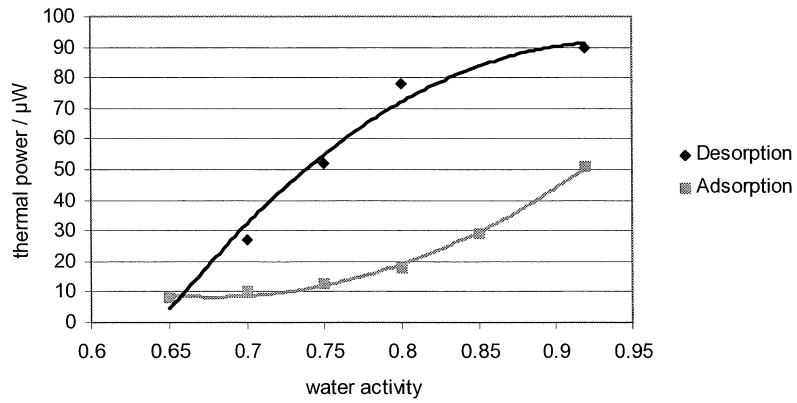

Figure 33: Thermal activities of bread mould (sample No. 1) in different water activities

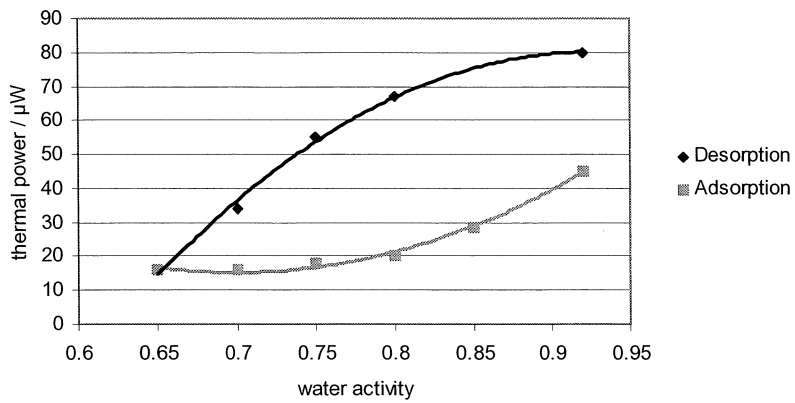

Figure 34: Thermal activities of bread mould (sample No. 2) in different water activities

6.0 Conclusion

The growth of fungi on building materials with organic compounds is influenced by several major factors: moisture, temperature, nutrients and oxygen. The temperature and oxygen concentration indoors are always (almost) within the limits for mould growth. The humidity level in the buildings varies and it can be within or outside the limits for mould to grow. Therefore, moisture is the key factor for fungal growth in buildings. However, the levels of moisture requirement for fungal growth are also influenced by the temperature, oxygen and building material properties. Therefore, in order to understand the fungal growth pattern in buildings, the combined influence of growth factors should be studied.

Isothermal calorimetry is a general, sensitive and quick method to study the influence of environmental factors on the fungal activities; something that is more difficult with other used methods. The results from calorespirometric measurements of several fungi confirmed previous studies, but the calorespirometric method took much shorter time. The comparison of results of calorimetry and ergosterol quantification showed that there is a correlation between the total heat production (total metabolism) and the biomass (reflected by the ergosterol amount). Measurements of thermal power as a function of water activity were also successful. This shows that the calorimetric methods are useful in fundamental mycological studies.

7.0 Future Work

Within the continuation of this work we plan to concentrate on the following measurements:

- Make more measurements on the correlation between heat production and ergosterol content.
- Run different building related mould fungi on building related substrates in the humidity generator and the calorimeter to map the fungal activity as a function of temperature and relative humidity.
- Make tests of temperature tolerance with different strains of *S. lacrymans* using a calorimetric method.

Using the data of mould activity as a function of temperature and relative humidity we will show how these can be used by making simulations of building parts and then calculating relative fungal biomass for different cases.

Outside the scope of this project the following tasks are interesting in relation to isothermal calorimetry and fungi:

- Continued development of non-steady state evaluation methods for the calorespirometric method described in paper I.
- Make measurements of possible thermal adaptation of *S. lacrymans* to high temperature and how this is influenced by the water activity.
- Using isothermal calorimetry to detect fungal activity and other biological activity, e.g., in foodstuffs. There have been several studies of this (Lampi et al. 1974; Gram and Sogaard 1985; Nunomura et al. 1986; Iversen et al. 1989; Almqvist et al. 1991; Riva et al. 2001; Alklint et al. 2004) but yet no practical applications. The technique may have practical applications as one can measure heat without opening packages. (There has actually been proposed calorimetric devices for this purpose) (Sacks and Menefee 1972; Demeijer et al. 1998).
- Using calorimetry or calorespirometry on mixed microbial populations, e.g., in soil, for ecological studies. Calorimetry is a rapid method to quantify the influence of acutely toxic substances on biological processes.

Bibliography

- Adan, O. C. G. (1994). *On the fungal defacement of interior finishes*. Doctoral dissertation. Eindhoven University of Technology, Eindhoven, The Netherlands.
- Alklint, C., Wadsö, L. and Sjöholm, I. (2004). "Effects of modified atmosphere on shelf-life of carrot juice." *Food Control* 15: 131-137.
- Almqvist, S., Dunäs, L., Rörström, A. and Wiernik, A. (1991). *Microcalorimetry: a useful tool for solving shelf life problems in the food industry*. Thermometric AB.
- Anderberg, A. (2004). *Moisture properties of self-levelling flooring compounds*. Licentiate thesis, Byggnadsmaterial, LTH. Lund University, Lund, Sweden.
- Anderberg, A. and Wadsö, L. (2004). *Moisture in self-levelling flooring compounds - Sorption isotherms*. Byggnadsmaterial, LTH, Lund University, Lund, Sweden.
- Andersen, B., Nielsen, K. F., Thrane, U., Szaro, T., Taylor, J. W. and Jarvis, B. B. (2003). "Molecular and phenotypic descriptions of *Stachybotrys chlorohalonata* sp. nov. and two chemotypes of *Stachybotrys chartarum* found in water-damaged buildings." *Mycologia* 95(6): 1227-1238.
- Andersson, M. A., Nikulin, M., Koljalg, U., Andersson, M. C., Rainey, F., Reijula, K., Hintikka, E. L. and SalkinojaSalonen, M. (1997). "Bacteria, molds, and toxins in water-damaged building materials." *Applied and Environmental Microbiology* 63(2): 387-393.
- Anink, D., Boonstra, C. and Mak, J. (1996). *Handbook of sustainable building - An environmental preference method for selection of materials for use in construction and refurbishment*, James & James (Science Publishers) Ltd.
- Appleby, P. (1992). Ventilation for control of airborne pollutants. *Indoor Air Pollution, Problems and priorities*. G. B. Leslie and Lunau, F. W. Cambridge, UK, Cambridge University Press.
- Atwater, W. O. and Rosa, E. B. (1899). *Description of New Respiration Calorimeter and Experiments on the Conservation of Energy in the Human Body*. Bulletin 63, U.S. Department of Agriculture, Office of Experiment Stations, Government Printing Office, Washington, D. C.
- Axelsson, B. O., Saraf, A. and Larsson, L. (1995). "Determination of ergosterol in organic dust by Gas-Chromatography Mass-Spectrometry." *Journal of Chromatography B-Biomedical Applications* 666(1): 77-84.
- Ayerst, G. (1969). "Effects of moisture and temperature on growth and spore germination in some fungi." *Journal of Stored Products Research* 5(2): 127-141.
- Battley, E. H. (1987). *Energetics of Microbial Growth*. Stony Brook, John Wiley & Sons.
- Battley, E. H. (1999). The thermodynamics of microbial growth. *Handbook of Thermal Analysis and Calorimetry*. P. K. Gallagher, Elsevier. 4: 219-266.
- Bech-Andersen, J. (1995). *The dry rot fungus and other fungi in houses*. Holte, Denmark, Hussvamp Laboratoriet ApS.
- Bjurman, J. (1994). "Ergosterol as an indicator of mold growth on wood in relation to culture age, humidity stress and nutrient level." *International Biodeterioration & Biodegradation* 33(4): 355-368.

- Bjurman, J. (1999). "Fungal and microbial activity in external wooden panels as determined by finish, exposure, and construction techniques." *International Biodeterioration & Biodegradation* 43(1-2): 1-5.
- Burke, S., Johansson, D. and Öberg, M. (2002). *Examination of operational energy use and physical function by utilizing building physics tools*. Report, Energi- och resurshushållning i bebyggelse, Department of Building Physics, Lund University, Lund, Sweden.
- Carlile, M. J., Watkinson, S. C. and Gooday, G. W. (2001). *The fungi*. London, Academic Press.
- Chen, N., Hsiang, T. and Goodwin, P. H. (2003). "Use of green fluorescent protein to quantify the growth of *Colletotrichum* during infection of tobacco." *Journal of Microbiological Methods* 53: 113-122.
- Cooley, J. D., Wong, W. C., Jumper, C. A. and Straus, D. C. (1998). "Correlation between the prevalence of certain fungi and sick building syndrome." *Occupational and Environmental Medicine* 55(9): 579-584.
- Criddle, R. S., Breidenbach, R. W. and Hansen, L. D. (1991a). "Plant calorimetry - How to quantitatively compare apples and oranges." *Thermochimica Acta* 193: 67-90.
- Criddle, R. S., Breidenbach, R. W., Lewis, E. A., Eatough, D. J. and Hansen, L. D. (1988). "Effects of temperature and oxygen depletion on metabolic rates of tomato and carrot cell-cultures and cuttings measured by calorimetry." *Plant Cell and Environment* 11(8): 695-701.
- Criddle, R. S., Breidenbach, R. W., Rank, D. R., Hopkin, M. S. and Hansen, L. D. (1990). "Simultaneous calorimetric and respirometric measurements on plant tissues." *Thermochimica Acta* 172: 213-221.
- Criddle, R. S., Fontana, A. J., Rank, D. R., Paige, D., Hansen, L. D. and Breidenbach, R. W. (1991b). "Simultaneous measurement of metabolic heat rate, CO₂ production, and O₂ consumption by microcalorimetry." *Analytical Biochemistry* 194(2): 413-417.
- Criddle, R. S. and Hansen, L. D. (1999). Calorimetric methods for analysis of plant metabolism. *Handbook of Thermal Analysis and Calorimetry*. P. K. Gallagher, Elsevier. 4: 711-763.
- Critter, S. A. M., Freitas, S. S. and Airolidi, C. (2001). "Calorimetry versus respirometry for the monitoring of microbial activity in a tropical soil." *Applied Soil Ecology* 18(3): 217-227.
- Deacon, J. W. (2001). *Modern mycology*. London, Blackwell Science.
- Demeijer, E., Nihtianov, S., Meijer, G. and Kerkvliet, H. (1998). An experimental sterility-testing calorimeter. *Automatic Control of Food and Biological Processes*. C. Sköldebrand and Trystram, G. Gothenburg, Sweden, SIK: 31-42.
- Duboc, P., Marison, I. and von Stockar, U. (1999). Quantitative calorimetry and biochemical engineering. *Handbook of Thermal Analysis and Calorimetry*. P. K. Gallagher, Elsevier. 4: 267-365.
- Duggal, S. K. (1998). *Building materials*. Rotterdam, Netherlands, A.A. Balkema.
- Fontana, A. J., Hilt, K. L., Paige, D., Hansen, L. D. and Criddle, R. S. (1995). "Calorespirometric analysis of plant - Tissue metabolism using calorimetry and pressure measurement." *Thermochimica Acta* 258: 1-14.
- Frankland, J. C., Dighton, J. and Boddy, L. (1990). Methods for studying fungi in soil and forest litter. *Methods in Microbiology*. R. Grigorova and Norris, J. R. London, Academic Press. 22: 343-404.

- Fujiyoshi, M., Nakatsubo, T., Ogura, S. and Horikoshi, T. (2000). "Estimation of mycelial biomass of arbuscular mycorrhizal fungi associated with the annual legume *Kummerowia striata* by ergosterol analysis." *Ecological Research* 15(2): 121-131.
- Gal, S. (1972). "Expression of concentration of water vapor in water vapor sorption measurements." *Helvetica Chimica Acta* 55(5): 1752-1757.
- Gnaiger, E. and Forstner, H., Eds. (1983). Polarographic oxygen sensors: aquatic and physiological applications, Berlin : Springer-Verlag.
- Gnaiger, E. and Kemp, R. B. (1990). "Anaerobic metabolism in aerobic mammalian-cells - Information from the ratio of calorimetric heat-flux and respirometric oxygen flux." *Biochimica Et Biophysica Acta* 1016(3): 328-332.
- Gnaiger, E., Shick, J. M. and Widdows, J. (1989). Metabolic microcalorimetry and respirometry of aquatic animals. *Soc. Exp. Bio. Seminar Series*, Cambridge Univ. Press.
- Gomez, F., Toledo, R. T., Wadsö, L., Gekas, V. and Sjöholm, I. (2004). "Isothermal calorimetry approach to evaluate tissue damage in carrot slices upon thermal processing." *Journal of Food Engineering* 65(2): 165-173.
- Gram, L. and Sogaard, H. (1985). "Microcalorimetry as a rapid method for estimation of bacterial levels in ground meat." *Journal of Food Protection* 48(4): 341-345.
- Grant, C., Hunter, C. A., Flannigan, B. and Bravery, A. F. (1989). "The moisture requirements of moulds isolated from domestic dwellings." *International Biodeterioration* 25(4): 259-284.
- Grant, W. D. and West, A. W. (1986). "Measurement of ergosterol, diaminopimelic acid and glucosamine in soil - evaluation as indicators of microbial biomass." *Journal of Microbiological Methods* 6(1): 47-53.
- Gravesen, S., Frisvad, J. C. and Samson, R. A. (1994). *Microfungi*. Copenhagen, Munksgaard.
- Gu, J. D., Ford, T. E., Berke, N. S. and Mitchell, R. (1998). "Biodeterioration of concrete by the fungus *Fusarium*." *International Biodeterioration & Biodegradation* 41(2): 101-109.
- Hagentoft, C.-E. (2001). *Introduction to building physics*. Lund, Studentlitteratur.
- Haines, P. J., Reading, M. and Wilburn, F. W. (1998). Differential thermal analysis and differential scanning calorimetry. *Handbook of Thermal Analysis and Calorimetry*. P. K. Gallagher, Elsevier. 1: 279-361.
- Hand, S. C. (1999). Calorimetric approaches to animal physiology and bioenergetics. *Handbook of Thermal Analysis and Calorimetry*. P. K. Gallagher, Elsevier. 4: 469-510.
- Hansen, L. D., Hopkin, M. S., Taylor, D. K., Anekonda, T. S., Rank, D. R., Breidenbach, R. W. and Criddle, R. S. (1995). "Plant calorimetry 2. Modeling the differences between apples and oranges." *Thermochimica Acta* 250(2): 215-232.
- Hansen, L. D., Macfarlane, C., McKinnon, N., Smith, B. N. and Criddle, R. S. (2004). "Use of calorespirometric ratios, heat per CO₂ and heat per O₂, to quantify metabolic paths and energetics of growing cells." *Thermochimica Acta* 422: 55-61.
- Hansen, L. D., Smith, B. N. and Criddle, R. S. (1998). "Calorimetry of plant metabolism: A means to rapidly increase agricultural biomass production." *Pure and Applied Chemistry* 70(3): 687-694.

- Hegarty, B. (1991). Factors Affecting the Fruiting of the Dry Rot Fungus *Serpula lacrymans*. *Serpula lacrymans: Fundamental biology and control strategies*. D. H. Jennings and Bravery, A. F., John Wiley & Sons: 39-53.
- Hemming, D. J. B., Monaco, T. A., Hansen, L. D. and Smith, B. N. (2000). "Respiration as measured by scanning calorimetry reflects the temperature dependence of different soybean cultivars." *Thermochimica Acta* 349(1-2): 131-134.
- Herbert, R. A. (1990). Methods for enumerating microorganisms and determining biomass in natural environments. *Methods in Microbiology*. R. Grigorova and Norris, J. R., Academic Press. 22: 1-40.
- Hyvarinen, A., Meklin, T., Vepsäläinen, A. and Nevalainen, A. (2002). "Fungi and actinobacteria in moisture-damaged building materials - concentrations and diversity." *International Biodeterioration & Biodegradation* 49(1): 27-37.
- Hyvärinen, A., Meklin, T., Vepsäläinen, A. and Nevalainen, A. (2002). "Fungi and actinobacteria in moisture-damaged building materials - concentrations and diversity." *International Biodeterioration & Biodegradation* 49(1): 27-37.
- Iversen, E., Wilhelmssen, E. and Criddle, R. S. (1989). "Calorimetric examination of cut fresh pineapple metabolism." *Journal of Food Science* 54(5): 1246-1249.
- Jennings, D. H. (1991). The physiology and biochemistry of the vegetative mycelium. *Serpula lacrymans: fundamental biology and control strategies*. D. H. Jennings and Bravery, A. F., John Wiley & Sons: 55-79.
- Jennings, D. H. and Bravery, A. F., Eds. (1991). *Serpula lacrymans: fundamental biology and control strategies*, John Wiley & Sons Ltd.
- Johansson, S. (2004). personal communication. Lund.
- Jones, A. P. (1999). "Indoor air quality and health." *Atmospheric Environment* 33(28): 4535-4564.
- Kemp, R. (1998). Nonscanning calorimetry. *Handbook of Thermal Analysis and Calorimetry*. P. K. Gallagher, Elsevier. 1: 577-675.
- Kemp, R. and Guan, Y. H. (1999). Microcalorimetric studies of animal tissues and their isolated cells. *Handbook of Thermal Analysis and Calorimetry*. P. K. Gallagher, Elsevier. 4: 557-656.
- King, N. and Auger, P. (2002). "Indoor air quality, fungi, and health - How do we stand?" *Canadian Family Physician* 48: 298-302.
- Klamer, M. and Baath, E. (2004). "Estimation of conversion factors for fungal biomass determination in compost using ergosterol and PLFA 18 : 2 omega 6,9." *Soil Biology & Biochemistry* 36(1): 57-65.
- Kleiber, M. (1961). *The Fire of Life*. New York, John Wiley & Sons, Inc.
- Labuza, T. P., Hawkes, J., Gallaghe, D., Hurtado, F. and McNally, L. (1972). "Stability of intermediate moisture foods .1. lipid oxidation." *Journal of Food Science* 37(1): 154-159.
- Lamar, R., Schoenike, B., Vanden Wymelenberg, A., Stewart, P., Dietrich, D. and Cullen, D. (1995). "Quantitation of fungal mRNAs in complex substrates by reverse transcription PCR and its application to *Phanerochaete chrysosporium*- colonized soil." *Applied and Environmental Microbiology* 61(6): 2122-2126.
- Lampi, R. A., Mikelson, D. A., Rowley, D. B., Previte, J. J. and Wells, R. E. (1974). "Radiometry and microcalorimetry - techniques for rapid detection of foodborne microorganisms." *Food Technology* 28(10): 52-&.
- Lamprecht, I. and Schmolz, E. (1999). Calorimetry of small animals. *Handbook of Thermal Analysis and Calorimetry*. P. K. Gallagher, Elsevier. 4: 405-467.

- Larsson, B. and Gustafsson, L. (1999). Calorimetry of microbial processes. *Handbook of Thermal Analysis and Calorimetry*. P. K. Gallagher, Elsevier. 4: 367-404.
- Larsson, L. and Larsson, P. F. (2001). "Analysis of chemical markers as a means of characterising airborne micro-organisms in indoor environments: A case study." *Indoor and Built Environment* 10(3-4): 232-237.
- Lavoisier, A. and Laplace, P. S. (1783). "Mémoire sur la chaleur." *Mémoires de l'Académie des sciences* 3: 355-408.
- Lunau, F. W. (1992). The perception of indoor air quality. *Indoor Air Pollution, Problems and priorities*. G. B. Leslie and Lunau, F. W. Cambridge, Cambridge University Press: 9-18.
- Macfarlane, C., Adams, M. A. and Hansen, L. D. (2002). "Application of an enthalpy balance model of the relation between growth and respiration to temperature acclimation of *Eucalyptus globulus* seedlings." *Proceedings of the Royal Society of London Series B-Biological Sciences* 269(1499): 1499-1507.
- Magan, N. and Lacey, J. (1984). "Effects of gas-composition and water activity on growth of field and storage fungi and their interactions." *Transactions of the British Mycological Society* 82(MAR): 305-314.
- McNeel, S. and Kreutzer, R. A. (1996). "Fungi and indoor air quality." *Health & Environment Digest* 10(2): 9-12.
- Meininghaus, R., Gunnarsen, L. and Knudsen, H. N. (2000). "Diffusion and sorption of volatile organic compounds in building materials - Impacts on indoor air quality." *Environmental Science and Technology* 34: 3101-3108.
- Miller, J. D. (1992). "Fungi as contaminants in indoor air." *Atmospheric Environment* 26A(12): 2163-2172.
- Monti, M. (1999). Calorimetric studies in medicine. *Handbook of Thermal Analysis and Calorimetry*. P. K. Gallagher, Elsevier. 4: 657-710.
- Nakano, T. (2003). "Effects of cell structure on water sorption for wood." *Holzforschung* 57: 213-218.
- Nevalainen, A., Pasanen, A.-L., Niininen, M., Reponen, T., Kalliokoski, P. and Jantunen, M. J. (1991). "The indoor air quality in Finnish homes with mold problems." *Environment International* 17(4): 299-302.
- Nevander, L. E. and Elmarsson, B. (1991). *Fuktdimensionering av träkonstruktioner (Moisture dimensions of wood constructions)*. Lund Tekniska Högskola, Lund University, Lund.
- Nevander, L. E. and Elmarsson, B. (1994). *Fukt handbok*, Svensk Byggtjänst.
- Newell, S. Y. (1992). Estimating fungal biomass and productivity in decomposing litter. *The Fungal Community, Its organization and role in the ecosystem*. G. C. Carroll and Wicklow, D. T. New York, Marcel Dekker, Inc.: 521-561.
- Nicholls, P. J. (1992). Vegetable dusts and lung disease. *Indoor air pollution, problems and priorities*. G. B. Leslie and Lunau, F. W. Cambridge, Cambridge University Press.
- Nielsen, K. F. (2001). *Mould growth on building materials, secondary metabolites, mycotoxins and biomarkers*. Doctoral dissertation, Biocentrum. Technical University of Denmark, Lyngby, Denmark.
- Nilsson, K. and Bjurman, J. (1990). "Estimation of mycelial biomass by determination of the ergosterol content of wood decayed by *Coniophora puteana* and *Fomes fomentarius*." *Material Und Organismen* 25(4): 275-285.
- Nilsson, K. and Bjurman, J. (1998). "Chitin as an indicator of the biomass of two wood-decay fungi in relation to temperature, incubation time, and media composition." *Canadian Journal of Microbiology* 44(6): 575-581.

- Norbäck, D., Wälinder, R., Wieslander, G., Smedje, G., Erwall, C. and Venge, P. (2000). "Indoor air pollutants in schools: nasal patency and biomarkers in nasal lavage." *Allergy* 55: 163-170.
- Northolt, M. D. and Bullerman, L. B. (1982). "Prevention of mold growth and toxin production through control of environmental-conditions." *Journal of Food Protection* 45(6): 519-526.
- Nunomura, K., Kisook, K. and Fujita, T. (1986). "Calorimetric studies of microbial activities in relation to the water-content of food." *Journal of General and Applied Microbiology* 32(4): 361-365.
- Nuss, I., Jennings, D. H. and Veltkamp, C. J. (1991). Morphology of *Serpula lacrymans*. *Serpula lacrymans: Fundamental biology and control strategies*. D. H. Jennings and Bravery, A. F., John Wiley & Sons: 10-38.
- Nyqvist, H. (1983). "Saturated salt solutions for maintaining specified relative humidities." *Int. J. Pharm. Tech. & Prod. Mfr.* 4(2): 47-48.
- Pasanen, A. L., Juutinen, T., Jantunen, M. J. and Kalliokoski, P. (1992). "Occurrence and moisture requirements of microbial-growth in building-materials." *International Biodeterioration & Biodegradation* 30(4): 273-283.
- Pasanen, A. L., Rautiala, S., Kasanen, J. P., Raunio, P., Rantamaki, J. and Kalliokoski, P. (2000). "The relationship between measured moisture conditions and fungal concentrations in water-damaged building materials." *Indoor Air-International Journal of Indoor Air Quality and Climate* 10(2): 111-120.
- Pegler, D. N. (1991). Taxonomy, Identification and Recognition of *Serpula lacrymans*. *Serpula lacrymans: Fundamental biology and control strategies*. D. H. Jennings and Bravery, A. F., John Wiley & Sons: 1-7.
- Prescott, L. M., Harley, J. P. and Klein, D. A. (2003). *Microbiology*, McGraw Hill.
- Rao, C., Burge, H. and Chang, J. (1996). "Review of quantitative standards and guidelines for fungi in indoor air." *Journal of Air and Waste Management Association* 46(9): 899-908.
- Riva, M., Fessas, D. and Schiraldi, A. (2001). "Isothermal calorimetry approach to evaluate shelf life of foods." *Thermochimica Acta* 370(1-2): 73-81.
- Sacks, L. E. and Menefee, E. (1972). "Thermal detection of spoilage in canned foods." *Journal of Food Science* 37(6): 928-931.
- Samson, R. A., Hoekstra, E. S., Frisvad, J. C. and Filtenborg, O. (2000). *Introduction to food and airborne fungi*. Utrecht, The Netherlands, Ponsen & Looyen, Wageningen.
- Saraf, A. and Larsson, L. (1996). "Use of gas chromatography ion-trap tandem mass spectrometry for the determination of chemical markers of microorganisms in organic dust." *Journal of Mass Spectrometry* 31(4): 389-396.
- Saraf, A., Larsson, L., Burge, H. and Milton, D. (1997). "Quantification of ergosterol and 3-hydroxy fatty acids in settled house dust by gas chromatography mass spectrometry: Comparison with fungal culture and determination of endotoxin by a *Limulus amoebocyte* lysate assay." *Applied and Environmental Microbiology* 63(7): 2554-2559.
- Sarwar, G., Corsi, R., Allen, D. and Weschler, C. (2003). "The significance of secondary organic aerosol formation and growth in buildings: Experimental and computational evidence." *Atmospheric Environment* 37(9-10): 1365-1381.
- Scheffer, T. C. (1986). "O₂ requirements for growth and survival of wood-decaying and sapwood-staining fungi." *Canadian Journal of Botany-Revue Canadienne De Botanique* 64(9): 1957-1963.

- Scott, W. (1957). "Water relations of food spoilage microorganisms." *Advances in Food Research* 7: 83-127.
- Sedlbauer, K. (2001). *Vorhersage von schimmelpilzbildung auf und in bauteilen (Prediction of mould fungus formation on the surface of and inside building components)*. Fraunhofer Institute for Building Physics. Universität Stuttgart.
- Sedlbauer, K. (2002). "Beurteilung von schimmelpilzbildung auf und in bauteilen - Evaluation of mould growth in construction elements." *Bauphysik* 24: 167-176.
- Shiraldi, A., Piazza, L., Fessas, D. and Riva, M. (1999). Thermal analysis in foods and food processes. *Handbook of Thermal Analysis and Calorimetry*. P. K. Gallagher, Elsevier. 4: 829-921.
- Siau, J. F. (1984). *Transport processes in wood*. Berlin, Springer-Verlag.
- Singh, J. (1999). "Dry rot and other wood-destroying fungi: Their occurrence, biology, pathology and control." *Indoor and Built Environment* 8(1): 3-20.
- Thornton, W. M. (1917). "The relation of oxygen to the heat of combustion of organic compounds." *Philosophical Magazine* 33: 196-203.
- Tuomi, T., Reijula, K., Johnsson, T., Hemminki, K., Hintikka, E.-L., Lindroos, O., Kalso, S., Koukila-Kahkola, P., Mussalo-Rauhamaa, H. and Haahtela, T. (2000). "Mycotoxins in crude building materials from water-damaged buildings." *Applied and environmental microbiology* 66(5): 1899-1904.
- Viitanen, H. (1996). *Factors affecting the development of mould and brown rot decay in wooden material and wooden structures*. Doctoral dissertation, Department of Forest Products. Uppsala University, Uppsala, Sweden.
- Wadsö, L. (1993). *Studies of Water Vapor Transport and Sorption in Wood*. Doctoral dissertation, Building Materials. Lund University, Lund, Sweden.
- Wadsö, L. (1996). Microcalorimetry as a tool for studies of fungal degradation of wood. *Trä Färg Fukt "Wood Paint & Moisture"*, Stockholm.
- Wadsö, L. (1997). "Principles of a microcalorimetric technique for the study of mould activity as a function of relative humidity." *Journal of Thermal Analysis* 49(2): 1053-1060.
- Wadsö, L. (2003). A multi channel isothermal heat conduction calorimeter for cement hydration studies. *International Congress of the Chemistry of Cement*, Durban, South Africa.
- Wadsö, L., Gomez, F., Sjöholm, I. and Rocculi, P. (2004a). "Effect of tissue wounding on the results from calorimetric measurements of vegetable respiration." *Thermochimica Acta* 422(1-2): 89-93.
- Wadsö, L., Li, Y. and Bjurman, J. (2004b). "Measurements on two mould fungi with a calorimetric method." *Thermochimica Acta* 422: 63-68.
- Wang, Q. (1994). "Growth of mould and stain fungi on wood-based boards in relation to temperature and relative-humidity." *Material Und Organismen* 28(2): 81-103.
- Wanyoike, M. W., Walker, F. and Buchenauer, H. (2002). "Relationship between virulence, fungal biomass and mycotoxin production by *Fusarium graminearum* in winter wheat head blight." *Zeitschrift fuer Pflanzenkrankheiten und Pflanzenschutz* 109(6): 589-600.
- Webb, J. S., Nixon, M., Eastwood, I. M., Greenhalgh, M., Robson, G. D. and Handley, P. S. (2000). "Fungal colonization and biodeterioration of plasticized polyvinyl chloride." *Applied and Environmental Microbiology* 66(8): 3194-3200.

- Willcock, J. and Magan, N. (2001). "Impact of environmental factors on fungal respiration and dry matter losses in wheat straw." *Journal of Stored Products Research* 37(1): 35-45.
- Wolkoff, P. and Nielsen, G. D. (2001). "Organic compounds in indoor air--their relevance for perceived indoor air quality?" *Atmospheric Environment* 35(26): 4407-4417.
- Xie, Y., Bjurman, J. and Wadsö, L. (1997). "Microcalorimetric characterization of the recovery of a brown-rot fungus after exposures to high and low temperature, oxygen depletion, and drying." *Holzforschung* 51(3): 201-206.
- Zimmerman, M. H. (1983). *Xylem structure and the ascent of sap*. Berlin, Springer-Verlag.

Collection of papers

PAPER I

Measurements on two mould fungi with a calorespirometric method

PAPER II

Correlating two method of quantifying fungal activity: ergosterol amount by GC-MS-MS and heat production by isothermal calorimetry

PAPER I

Measurements on two mould fungi with a calorespirometric method

Wadsö, L., Li, Y. and Bjurman, J. (2004). "Measurements on two mould fungi with a calorespirometric method." Thermochemica Acta **422**: 63–68.



Measurements on two mould fungi with a calorespirometric method[☆]

Lars Wadsö^{a,*}, Yujing Li^a, Jonny Bjurman^b

^a Building Materials, Lund University, Box 118, SE-22100 Lund, Sweden

^b Applied Environmental Science and Conservation, Gothenburg University, Sweden

Received 7 December 2003; received in revised form 12 May 2004; accepted 17 May 2004

Available online 15 September 2004

Abstract

This paper presents results from dynamic calorespirometric measurements on the two mould fungi *Penicillium roqueforti* and *P. camemberti* growing on agar. The measurements were made with two isothermal heat conduction calorimeters connected by a tube. In one of the calorimeters, the sample was placed and the other contained a carbon dioxide absorbent. Pressure sensors were connected to both the ampoules. The equipment also contained a valve on the tube that was opened and closed at regular intervals. Measurements were started at normal atmospheric pressure and gas composition, and continued after oxygen was consumed. The response of the fungi to the changing gas composition was followed and gas exchange ratios and metabolic enthalpies were calculated by approximate methods.
© 2004 Published by Elsevier B.V.

Keywords: Isothermal calorimetry; Respirometry; Penicillium; Oxygen; Carbon dioxide

1. Introduction

Both respirometry – the measurement of gas exchange – and calorimetry – the measurement of heat – are valuable techniques for the study of biological phenomena. Respirometry, as first used by Barcroft and Haldane in 1902 [1], has been used on a quite large scale [2], often referred to as Warburg respirometry. Calorimetry has an even longer history in biology as Lavoisier and Laplace measured the heat production of a guinea pig as early as 1783 [3]. During the last century, a large number of different calorimetric techniques have been used in the biological field, mainly on microbiological systems.

For aerobic respiration, the discovery by Thornton [4] that complete combustion of almost any organic compound produced a heat of about 450 kJ/mol(O₂) led to a linear connection between calorimetry and measurements of O₂ consumption by respirometry. It was also found that the

respiratory quotient (RQ, mol CO₂ produced per mol O₂ consumed) was almost constant within each of the three main types of biological substrates: for carbohydrates, lipids, and proteins the RQ has values of 1.0, about 0.72, and about 0.84 (meat protein), respectively [5,6]. If one expects that, e.g., only carbohydrate is used as substrate in a biological process it is thus possible to calculate the heat produced from a measurement of produced CO₂ or consumed O₂. This is used in indirect calorimetry, where one measures gas exchange and calculates the heat that is supposed to be produced.

The above reasoning may lead to the belief that respirometry and calorimetry always gives the same result, and that the techniques therefore are interchangeable. However, it has been shown that a combination of respirometry and calorimetry may give more information than either of the techniques would give by themselves. There are several reasons for this:

- The second rule above cannot be used for mixed substrates in which one does not know which component that is being consumed [7] or when other substances than carbohydrates, fats, and proteins are being metabolised.
- The above rules apply only to respiration (aerobic metabolism). In many cases, it is also interesting to study anaerobic processes.

[☆] Presented at the thirteenth meeting of the International Society for Biological Calorimetry, Würzburg-Veitschöchheim, Germany, 27 September to 1 October 2004.

* Corresponding author. Tel.: +46 46 2229592; fax: +46 46 2224427.

E-mail address: lars.wadso@byggtek.lth.se (L. Wadsö).

Nomenclature

ΔH	enthalpy change (J/mol(CO ₂))
Δn	change in amount during full cycle (mol)
p	total pressure (Pa)
P	thermal power (W)
Q	heat (J)
V	total volume of ampoules (m ³)
V_s	volume of sample ampoule (m ³)

Greek letter

ρ	metabolic gas exchange ratio (mol(O ₂)/mol(CO ₂))
--------	--

Indices

a	CO ₂ absorbent
s	biological sample

- It has also been shown that biological samples may show partly anaerobic metabolism even under aerobic conditions [8].
- For such complex samples as biological systems it is always an advantage to use more than one technique, simultaneously or in parallel.

A simultaneous measurement with both respirometry and calorimetry is called calorespirometry, a term coined by Gnaiger [7]. He and others use different combinations of calorimetry and O₂ and CO₂ electrodes to study biological processes in the liquid phase (bacteria, yeast, mammalian cells, human cells, etc.). Another principle is used by Hansen, Criddle and co-workers, who combined classical Warburg respirometry with calorimetry to study biological samples surrounded by a gas phase (the biochemical processes inside the biological samples of course still run in a liquid environment), in which, O₂ and CO₂ concentrations are measured. They have studied biological samples such as tomato tissue, corn meristem, lichens, insects and tree shoots [9–12]. Combined calorimetry and respirometry has also been performed in larger scale whole-body calorimeters and in bioreactor calorimeters.

Hansen, Criddle and co-workers uses two different calorespirometric set-ups based on isothermal calorimetry and Warburg respirometry:

1. The thermal power of a biological sample in a closed ampoule is measured before and after a CO₂ absorbent solution is placed in the ampoule [13]. The difference in thermal activity with and without CO₂ absorbent is used to calculate the CO₂ production rate as the enthalpy of reaction between CO₂ and the absorbent is known. As the pressure change rate in the ampoule is also measured, it is possible to calculate the O₂ consumption rate.

2. In the second set-up, the biological sample and the CO₂ absorbent are placed in two separate calorimeters with the ampoules connected by a tube [14]. Pressure is measured simultaneously. The produced CO₂ diffuses through the tube to react with the CO₂ absorbent. One can then evaluate the thermal power of the sample, the CO₂ production rate, and the O₂ consumption rate (from pressure change rate combined with CO₂ production rate).

It is also possible to use two similar sized biological samples that are placed in two calorimetric ampoules with and without CO₂ absorbent. This avoids the disturbance from inserting/removing the absorbent, but it is not always possible to produce two similar biological samples.

The above methods have been used for short-term measurements, assuming that conditions are constant during a measurement. However, in the study of how environmental parameters influence the metabolic activity of biological systems it is also interesting to run long-term experiments in which the concentrations of CO₂ and O₂ changes. We are therefore working with a dynamic calorespirometric method for long-term measurements under changing gas composition based on the second principle mentioned above [14].

Fungi are a unique group of organisms that play an important role as decomposers in the ecosystem. They are also of interest to mankind as serious plant parasites and as one of the major spoilers of commodities such as foodstuffs, textiles and building materials. Some fungi are also used, e.g. for the production of antibiotics and in the production of certain foodstuffs like soft cheeses.

In the present paper we present measurements on two mould fungi: *Penicillium roqueforti* and *P. camemberti*. These are normally used to produce soft cheese. *P. camemberti* usually grows on the surface of cheese as it is a typical aerobic organism. *P. roqueforti*, on the other hand, is usually found inside of cheese as it can tolerate higher CO₂ levels and lower O₂ levels than *P. camemberti* [15,16]. Haasum and Nielsen [17] found about 50% reduction of *P. camemberti* growth when CO₂ concentration was increased from 5 to 25%, while no reduction was seen for *P. roqueforti*. They also found that the effect of O₂ on both species is small.

The aim of this work is to develop a rapid calorespirometric method to determine the effect of different O₂ and CO₂ pressures on fungi and other organisms.

2. Measurement principle

2.1. Instrument – calorespirometer

The calorespirometric device consists of two isothermal calorimeters (Fig. 1) that are placed in a TAM Air thermostat (Thermometric AB, Järfälla, Sweden). The calorimeters are modified TAM Air calorimetric units [18]. Two 20-ml glass ampoules are placed in the calorimeters and are connected by a tube (length about 9 cm, diameter about 7 mm) that passes

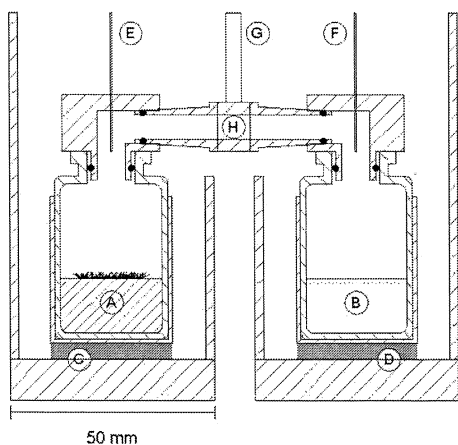
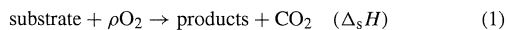

Fig. 1. A schematic drawing of the caloresspirometric device presented in the paper. A: Sample (agar with mould); B: CO₂ absorbent solution; C: sample calorimeter heat flow sensor; D: absorbent solution calorimeter heat flow sensor; E: sample ampoule pressure sensor tube; F: absorbent ampoule pressure sensor tube; G: shaft to turn valve; H: valve. Note that the drawing does not show the bottom parts of the heat sinks or the top part of the instrument with pressure sensors and step motor for valve operation. The instrument is placed in a thermostat.

through a slit that has been cut through both calorimeters. The sample is placed in one of the ampoules and the CO₂ absorbent is placed in the other. As CO₂ absorbent we used 0.4 M aqueous NaOH [13,14]. A valve is positioned on the tube and is controlled by a computer-controlled step motor placed outside the thermostat. Each ampoule is connected to an external pressure sensor (Motorola MPX5100) through a 0.3-mm inner diameter stainless steel tube.

2.2. Principle

From a simplified caloresspirometric viewpoint, biological metabolism can be expressed as in Eq. (1):



The metabolic gas exchange ratio ρ (see Nomenclature) is similar in its definition to the inverse of the respiratory quotient, but ρ is defined for both aerobic and anaerobic processes. For an aerobic process ρ is 1.0 for carbohydrate substrates and slightly higher for fats and proteins. For anaerobic metabolism ρ is zero as no O₂ is consumed. A value between zero and 1.0 indicates a combination of aerobic and anaerobic processes [8]. Note that Eq. (1) is only valid under steady-state conditions, both concerning the biological system itself and absorption/desorption processes outside the system that can influence respirometric measurements.

2.3. Operation

For a measurement, a biological sample was placed in the sample ampoule and the CO₂ absorbent was placed in the absorbent ampoule (Fig. 1). The ampoules were then placed in the calorimeters and the valve was left open. As it took at least 1 h before the calorimeters reached a steady state, and some O₂ had already been consumed by that time, humidified air was flushed through both ampoules through the pressure sensor tubes. This only marginally disturbed the thermal steady state, but assured that the measurement started with atmospheric conditions. The valve was left open from start, and was then switched at certain intervals. The thermal powers of sample and absorbent, and the pressures in each ampoule were recorded continuously. The disturbance from switching was small and could be neglected. The measurement started at aerobic conditions (20.9% O₂; corresponding to 21.3 kPa at an air pressure of 101.5 kPa) and continued into the anaerobic phase when the O₂ was consumed. It was then possible to flush the device again with air and repeat the measurement to check if the sample had grown or suffered damage during the first measurement.

It is not possible to continuously evaluate our measurements by directly combing the thermal power from the sample with the CO₂ consumption measured by the absorbent, as there is a time lag between these two events. We have instead made a simplified evaluation by integrating over each full valve cycle (open + closed) assuming that initial and final states of each cycle are identical. As this is not exactly true, there will be an error, but this error is in most cases rather small (discussed later). The integration over a full cycle has been made from/to the last data point before the valve was opened as these values are least disturbed by the events in connection to the valve changes.

Here follows the equations used to evaluate the measurements. The CO₂ production during a full valve cycle is the CO₂ consumed by the absorbent during this time:

$$\Delta n_{\text{CO}_2} = \frac{1}{\Delta_a H} \int_{\text{cycle}} P_a dt \quad (2)$$

The enthalpy of reaction between CO₂ (g) and the absorbent solution is 108.5 kJ/mol [14]. The O₂ consumption is proportional to the decrease in total pressure as the produced CO₂ is absorbed:

$$\Delta n_{\text{O}_2} = \frac{\Delta p_{\text{cycle}} V}{RT} \quad (3)$$

The heat produced by the sample is the integral of the sample thermal power:

$$Q_s = \int_{\text{cycle}} P_s dt \quad (4)$$

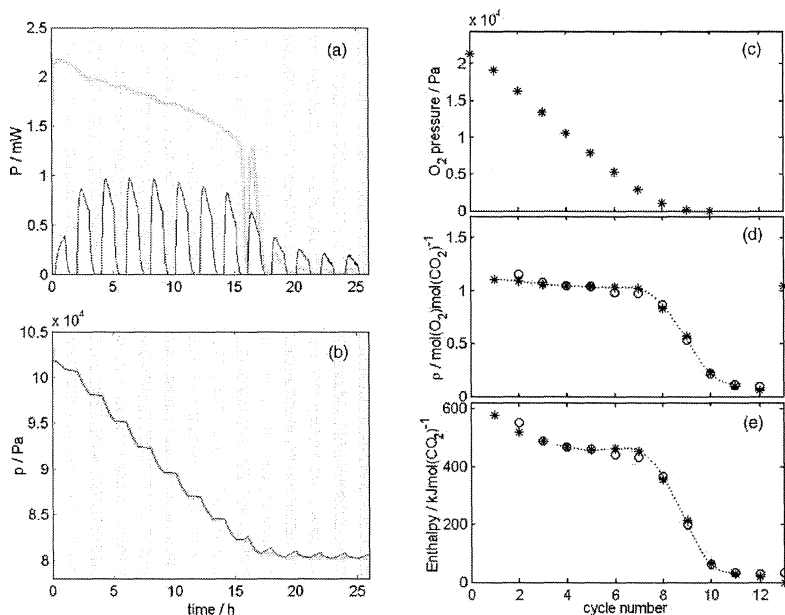

Fig. 2. Result of measurement with *P. roqueforti* growing on malt extract agar. The gray fields show when the valve is closed: (a) thermal power from *P. roqueforti* (gray line) and CO₂ absorbent (black line); (b) pressure changes measured in sample ampoule (gray line) and CO₂ absorbent (black line); (c) O₂ pressure; (d) metabolic gas exchange ratio calculated using Eq. (2) (stars) and Eq. (7) (circles); (e) metabolic enthalpy change calculated using Eq. (2) (circles) and Eq. (7) (stars).

From the above three equations we can, for each full cycle, calculate the metabolic gas exchange ratio:

$$\rho = \frac{\Delta n_{O_2}}{\Delta n_{CO_2}} \quad (5)$$

and the enthalpy of the metabolic processes:

$$\Delta_s H = \frac{Q_s}{\Delta n_{CO_2}} \quad (6)$$

We can also check Eqs. (2) and (3) by noting that the pressure change rate during the closed phase is proportional to the difference between the O₂ consumption rate and the CO₂ production rate. The overall change in gas amount during a full cycle is then

$$\Delta n_{CO_2} - \Delta n_{O_2} = (t_{open} + t_{closed}) \left(\frac{dp}{dt} \right)_{closed} \frac{V_s}{RT} \quad (7)$$

Eq. (7) is only valid for whole cycles in which the metabolic processes are the same during the open and closed phases.

3. Materials and method

We have tested the described method with measurements on strains of the two mould fungi *P. roqueforti* and *P. camemberti* that were inoculated on 10 ml malt extract agar

(Merck, Germany) in 20 ml glass ampoules 7 days before the measurements. The absorbent was 10 ml aqueous 0.4 M NaOH.

The measurements started with the valve open after the calorimeters had been flushed with air as described above. The valve was repeatedly closed and opened every 60 and 40 min, respectively. These time intervals were determined by the initial thermal activity to get about the same number of valve switches before the O₂ was consumed for both samples. Both measurements lasted well into the anaerobic phase. Then air was then flushed through the absorbent and sample ampoules again to check the state of the sample.

4. Results and discussion

The primary results of the measurements on *P. roqueforti* and *P. camemberti* are shown in parts a and b of Figs. 2 and 3. The evaluated parameters are shown in Figs. 2c–e and 3c–e. Figs. 2c and 3c give the O₂ pressure calculated by Eq. (3). As expected this decreases through the aerobic phase and stays constant at near zero during the anaerobic phase. Figs. 2d and 3d give the metabolic gas exchange ratio calculated by two methods. In one, Eqs. (2) and (3) are used to evaluate the O₂ and CO₂ rates, and in the other, Eqs. (3) and

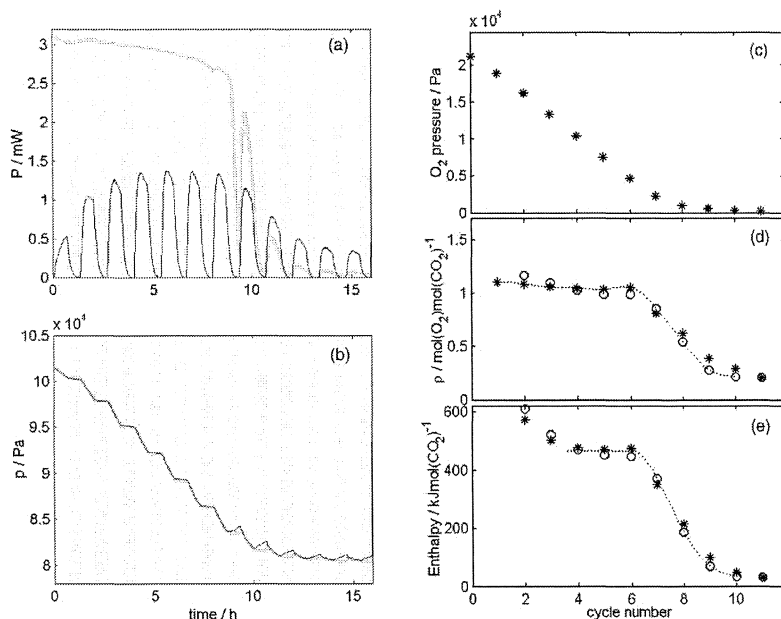

Fig. 3. Result of measurement with *P. camemberti* growing on malt extract agar. The gray fields show when the valve is closed: (a) thermal power from *P. camemberti* (gray line) and CO₂ absorbent (black line); (b) pressure changes measured in sample ampoule (gray line) and CO₂ absorbent (black line); (c) O₂ pressure; (d) metabolic gas exchange ratio calculated using Eq. (2) (stars) and Eq. (7) (circles); (e) metabolic enthalpy change calculated using Eq. (2) (circles) and Eq. (7) (stars).

(7) are used for the same purpose. There are two differences between these approaches: Eq. (2) is not valid for the first cycle in which there is a build-up of CO₂ in the system and Eq. (7) is not valid for the cycles in which the open phase is (at least partly) aerobic and the closed phase is anaerobic. The lines in Figs. 2d and 3d show the results that we believe are closest to the true result. Finally, Figs. 2e and 3e give the enthalpy of the metabolic processes calculated with two methods similar to the discussion above for the metabolic gas exchange ratio. The enthalpy values from the first cycles are higher than 469 kJ/mol(O₂) calculated for aerobic respiration of carbohydrates under the condition that O₂ and CO₂ are exchanged with the gas phase [8], but for the later aerobic cycles the calculated enthalpies agree well with this value. The deviation originates from the evaluation of the O₂ pressure by Eq. (3), as there is an influence from the evolved CO₂ that is not accounted for (the results shown in Figs. 2d and 3d are only marginally influenced by this).

The thermal power of *P. roqueforti* (Fig. 2) decreased slightly when the O₂ pressure decreased from 21.3 to 1 kPa. At lower O₂ pressures, the thermal power decreased to low values. An increasing pressure during the later closed phases indicates anaerobic CO₂ production. The metabolic gas exchange rate was about 1.0 when O₂ pressure was above about 1 kPa and then decreased to about zero. The metabolic

enthalpy of *P. roqueforti* was about 470 kJ/mol(CO₂) under aerobic conditions and about 30 kJ/mol(CO₂) for anaerobic conditions.

The results of measurements on *P. camemberti* (Fig. 3) were similar to those for *P. roqueforti* given above, except that the O₂ threshold was higher (the thermal power dropped to low values at 2–3 kPa). This suggests that *P. roqueforti* can stand lower O₂ concentrations than *P. camemberti*, which agrees with the known physiology of these two species [16].

As seen in Fig. 2a and b, the thermal power from *P. roqueforti* increases slightly during closed aerobic phases and decreases similarly during open phases. This is probably the result of the fungus increasing its activity as the CO₂ pressure increases (or a combined effect of changing O₂ and CO₂ pressures). No such behavior is seen for *P. camemberti*.

A detailed analysis of the thermal power curves for the mixed aerobic/anaerobic cycles (cycle 8 for *P. camemberti* and cycle 9 for *P. roqueforti*) shows that the fungi's response to the increased O₂ pressure when the valve is opened is almost identical to the absorbent's thermal power response to the increase in CO₂ when the valve is opened. As the reaction between CO₂ and the absorbent is rapid we conclude that the moulds show no time-lag in their response to increased O₂ pressure after a short anaerobic period.

During the last cycles, the sample thermal power is higher during the open parts than during the closed parts. This indicates that CO₂ inhibits the activity of the two fungi at low O₂ conditions.

After each measurement had been run for some cycles under anaerobic conditions, air was once again flushed through the ampoules. When the measurements were continued (results not shown) about 10% higher thermal powers were seen. This indicates that the fungi were not negatively affected by the experiments, but continued to grow during the measurements.

To do calorimetry, one needs a calorimeter and some other technique for determining O₂ and CO₂ rates. We have chosen to work with one more calorimeter and pressure sensors. The calorimeters used are of rather simple design and not of μ W-sensitivity. Pressure sensors are sensitive, inexpensive and robust compared to O₂ and CO₂ sensors, but we still lack evaluation tools for determining the CO₂ pressure during measurement. We only know that it increases during each closed phase, and decreases during each open phase. Computer simulations (not shown) indicate that the CO₂ concentrations stay well above zero even at the end of the open phase because of the rather large diffusion resistance in the tube, i.e. even if the valve was kept open during the whole measurement the CO₂ pressure would not go down to zero at the sample.

In general, the results of our measurements agree with what is known about *Penicillium* fungi, but we cannot explicitly state the trueness of our results as the method we have used involves some approximations and also many measured parameters (thermal powers, pressures, volumes). Another factor that needs further investigation is the possible influence of gas absorption/desorption by sample, substrate or the polymer parts of the valve.

We believe that a more detailed evaluation of the type of measurement described can be made by inverse techniques by taking into account the diffusion of the three gas components (N₂, O₂, CO₂) in the experimental system. More information can also be evaluated from a series of measurements, e.g. with different valve cycle programs.

The technique is useful for determining metabolic gas exchange ratios and metabolic enthalpies as functions of gas composition. It is also possible to quantitatively or qualitatively evaluate different aspects of fungal behavior, e.g. the rate and level of recovery after anaerobic conditions, and the influence of CO₂ pressure at aerobic and anaerobic conditions. The described technique can also be used for other organisms and other substrates.

5. Conclusions

We present calorimetric measurements of enthalpies and gas exchange ratios of two *Penicillium* fungi during long-term measurements from atmospheric aerobic conditions to anaerobic conditions. The results agree with literature data on *Penicillium* fungi, but the method needs further development before all parameters of interest can be evaluated.

Acknowledgements

We thank Assistant Professor Per Væggemose Nielsen at BioCentrum at the Technical University of Denmark for the mould strains we have used. We also acknowledge the financial support from FORMAS.

References

- [1] J. Barcroft, J.S. Haldane, *J. Physiol.* 28 (1902) 232–240.
- [2] W.W. Umbreit, R.H. Burris, J.F. Stauffer, *Manometric and Biochemical Techniques*, in: *A Manual Describing Methods Applicable to the Study of Tissue Metabolism*, 5th ed., Burgess Publishing Company, 1972.
- [3] A. Lavoisier, P.S. Laplace, *Mem. Acad. Sci.* 3 (1783) 355–408.
- [4] W.M. Thornton, *Philos. Mag.* 33 (1917) 196–203.
- [5] M. Kleiber, *The Fire of Life*, Wiley, New York, 1961.
- [6] E. Gnaiger, H. Forstner (Eds.), *Polarographic Oxygen Sensors: Aquatic and Physiological Applications*, Springer, Berlin, 1983.
- [7] E. Gnaiger, J.M. Shick, J. Widdows, *Metabolic microcalorimetry and respirometry of aquatic animals*, in: *Soc. Exp. Bio. Seminar Series*, Cambridge University Press, 1989.
- [8] E. Gnaiger, R.B. Kemp, *Biochim. Biophys. Acta* 1016 (1990) 328–332.
- [9] R.S. Criddle, R.W. Breidenbach, E.A. Lewis, D.J. Eatough, L.D. Hansen, *Plant, Cell Environ.* 11 (1988) 695–701.
- [10] R.S. Criddle, R.W. Breidenbach, L.D. Hansen, *Thermochim. Acta* 193 (1991) 67–90.
- [11] E.B. Acar, B.N. Smith, L.D. Hansen, G.M. Booth, *Environ. Entomol.* 30 (2001) 811–816.
- [12] C. Macfarlane, M.A. Adams, L.D. Hansen, *Proc. R. Soc. Lond. Ser. B: Biol. Sci.* 269 (2002) 1499–1507.
- [13] R.S. Criddle, R.W. Breidenbach, D.R. Rank, M.S. Hopkin, L.D. Hansen, *Thermochim. Acta* 172 (1990) 213–221.
- [14] R.S. Criddle, A.J. Fontana, D.R. Rank, D. Paige, L.D. Hansen, R.W. Breidenbach, *Anal. Biochem.* 194 (1991) 413–417.
- [15] C. Thom, J.N. Currie, *J. Biol. Chem.* 15 (1913) 249–258.
- [16] R.A. Samson, E.S. Hoekstra, J.C. Frisvad, O. Filtenborg (Eds.), *Introduction to Food and Airborne Fungi*, 6th ed., Ponsen and Looyen, Wageningen, 2000, p. 389.
- [17] I. Haasum, P.V. Nielsen, *J. Food Sci.* 63 (1998) 157–161.
- [18] L. Wadsö, A multi channel isothermal heat conduction calorimeter for cement hydration studies, in: *Proceedings of the International Congress of the Chemistry of Cement*, Durban, South Africa, 2003.

PAPER II

Correlating two method of quantifying fungal activity: ergosterol amount by GC-MS-MS and heat production by isothermal calorimetry

Yujing Li, Building Materials, Lund University, Sweden

Lars Wadsö, Building Materials, Lund University, Sweden

Lennart Larsson, Medical Microbiology, Lund University, Sweden

Jonny, Bjurman, Applied Environmental Science and Conservation, Göteborg University, Sweden

Correlating two method of quantifying fungal activity: ergosterol amount by GC-MS-MS and heat production by isothermal calorimetry

Draft: The paper will be complemented by more measurements before it will be submitted

Yujing Li, Building Materials, Lund University, Sweden*
Lars Wadsö, Building Materials, Lund University, Sweden
Lennart Larsson, Medical Microbiology, Lund University, Sweden
Jonny, Bjurman, Applied Environmental Science and Conservation, Göteborg University, Sweden

* Corresponding author. Yujing Li, Building Materials, Lund University, Box 118, 221 00 Lund, Sweden (yujing.li@byggttek.lth.se)

Abstract

Measurement of fungal growth or activity can be made by several different direct and indirect methods that focus on different aspects of fungal morphology, metabolism etc. In the present work we have correlated results from two quite different methods: isothermal calorimetry to measure the heat produced by the fungal respiration as a measure of integrated activity, and quantification of the fungal marker ergosterol by GC-MS-MS. The results show that heat and ergosterol content correlate fairly well, but further studies are needed to find the limits of the correlation.

Introduction

Measurement of fungal growth or activity can be made in many different ways depending on the aim of a study and the methods available. Some methods measure biomass or markers for biomass, for example total mass change, hyphal elongation, ergosterol or chitin content. Other methods more directly measure the activity of a fungal sample at the time of measurement: ATP concentration, heat production etc. A third group of methods concentrate on markers for specific fungi: spore and mycotoxin production are examples of such methods. Direct methods are often not possible for measurement of fungal colonization of natural solid materials. Growth of decay fungi is often estimated by the weight loss of solid substrates like wood.

It is obvious that the above mentioned methods are quite different considering what aspects of fungal growth they assess, and that two methods can give different results. For example will growth of a filamentous fungi always be by hyphal elongation, but mycotoxin production is much dependent on environmental conditions. This can be a problem, but can also be an advantage as the simultaneous use of more than one method will give more information that will either of the methods themselves. The aim of the present study was to investigate if there is a relation between produced heat and amount of ergosterol in growing fungal cultures.

Isothermal calorimetry is the measurement of thermal power (heat production rate or – more informally – thermal activity) at constant temperature. This is a very general measurement technique as nearly all processes (physical, chemical, biological) produce heat, that often can be measured. Isothermal calorimetry has been used in biology since 1780 when Lavoisier and LaPlace made their remarkable discovery of the similarity of chemical combustion and biological respiration. Over the years more and more sensitive calorimeters have been used in the biological field to study “from macromolecules to man” [REF]. Some examples of organisms studied (the references given are only examples) are germinating seeds [1], bacteria [2; 3], yeast cells [4; 3], other fungi [5; 6], plant tissue [7; 8], thermogenic flowers [9], vegetable tissue [8], human cells [10], mammal cells [11], insects [12], and fish [13].

The measurement of heat and thermal power has great generality as all biological processes produce heat. For fully aerobic respiration it has been found that for most (or all) substrates in biological systems the heat produced fall within the range $\Delta H_0 = -455 \pm 15$ kJ per mol oxygen consumed [14]. Calorimetry can then be used as a complement to respiration measurements. Under not fully aerobic or fully anaerobic conditions less heat is produced and the combination of respirometry and calorimetry (calorespirometry [15; 16; 14]) can then be used to elucidate the general nature of the biochemical processes.

In isothermal (heat conduction) calorimetry samples are usually placed in closed ampoules that are resting on heat flow sensors in contact with extremely well thermostated heat sinks. Ampoule sizes are typically 1-20 ml. A general trend in isothermal calorimetry has been towards more and more sensitive instruments. Today, much microbiological work is done with microcalorimeters that have baseline sensitivity in the order of 1 μ W (there are also more sensitive calorimeters, sometimes called nanocalorimeters, with sensitivities approaching the nW-range). However, in the present study we have worked with a slightly less sensitive instrument that has the advantage of containing eight separate calorimeters, so many measurements can be performed in parallel.

The other measurement technique employed in this work is the quantification of ergosterol by GC-MSMS. Ergosterol is a sterol that is found almost solely in the cell membranes of fungi, It is thus well suited to being a chemical fungal marker.

Ergosterol determination by HPLC with a UV detector was first introduced by Seitz et al, 1977 [17], as a measure of fungal growth in grain. Analyses have been done with or without an hydrolysis step. Since then ergosterol analyses have been used in many studies [18]. The method has also been characterized in relation to what the method actually determines. Total biomass, living biomass or activity. Several studies have shown that the amount of ergosterol is lower in mycelia growing on low nutrient media and is decreased as a result of moisture stress ([19; 20]) and in older cultures ([21]). The conversion factor relating ergosterol to biomass is thus highly variable. Even during short term experiments in surface liquid cultures the conversion factor for cultures of *Penicillium brevi-compactum* varied from 2 to 10 mg/g dry weight of mycelia ([20]).

Materials and methods

Materials

One organism-substrate combination has been investigated: the dry rot fungus *Serpula lacrymans* (strain "SL 1" from Haavard Kausrud, Oslo University, Norway) growing on 2 ml 2% malt extract agar (Merck). A total of 32 vials were inoculated, but only 24 were successfully measured by both techniques.

Sample preparation

Fungal samples were grown in 20 ml glass vials (inner diameter about 25 mm) on substrates initially humidified to close to 1.0 water activity and kept in this condition during the measurements by storing the vials over water in a large closed container between the calorimetric measurements. The relative humidity in the closed container was measured to be above 97% by a capacitive relative humidity probe. To prevent contamination of the samples wetted cotton plugs were placed in the openings of the vials.

The samples were inoculated at the center of the substrates with small inoculums taken from the margin of a colony grown on malt extract agar. All samples of one organism-substrate combination were inoculated simultaneously. The samples were then grown at 20°C in high humidity except when they were taken out, sealed with aluminum caps with Teflon-rubber septa, and measured in the isothermal calorimeter. Calorimetric measurements were made every day and then every second or third day on the remaining samples. At regular intervals samples were removed from the calorimetric measurements by placing them at -50°C to prevent further growth or ergosterol degradation.

Samples with un-inoculated agar and empty vials were used as blanks.

Isothermal calorimetry

In the present project a TAM Air (Thermometric AB, Järfälla, Sweden) instrument containing eight separate isothermal calorimeters have been used. The measurements took place at $20.0 \pm 0.1^\circ\text{C}$. Each calorimeter contains a reference sample that in the present measurement contained an identical glass vial as were used in the measurement, but with 2 ml water instead of agar. The calorimeter was calibrated electrically with external heaters placed in 20 ml glass ampoules. In the samples with un-inoculated agar (and also in the inoculated samples that had not started to grow yet) a negative thermal power exponentially approaching zero was seen during the first five days measurements. We believe this was produced by un-known processes in the agar and have therefore subtracted it from the results from inoculated samples. The correction may not have been perfect as many samples showed low initial positive or negative thermal powers, such as the negative thermal powers seen in Fig. 1. This factor needs to be better controlled in future experiments.

Each time a sample is charged into the calorimeter it takes about 30 min to reach steady-state. After that quite constant thermal powers (in the range 0-0.5 mW in the present measurements) were measured. Each measurement lasted about 120 minutes and the mean thermal power at 90-110 min was used in the evaluation. To evaluate the heat produced during the period from inoculation to freezing at -50°C the integral of the measured thermal power was calculated using linear interpolation between the measured points. This is illustrated for one sample in Fig. 1.

Ergosterol quantification by GC-MS-MS

When all calorimetric measurements were finished the vials were taken from -50°C to the laboratory where the ergosterol quantification took place. They were then kept at -20°C until further processed and analysed as described previously [22]. In brief, samples were heated in 10% methanolic KOH at 80°C for 90 min and partitioned with heptane:water (1:1, v/v); the heptane extraction was repeated once. The combined heptane phases were evaporated to dryness, dissolved in 1 ml of heptane:dichloromethane (1:1, v/v), and purified using a disposable silica gel column. Derivatisation was performed by heating in BSTFA (50 μl) and pyridine (5 μl) at 60°C for 30 min. Heptane (50 μl) was added to each preparation prior to analysis by using GC-MSMS, and quantification was made by using dehydrocholesterol as an internal standard [22].

Results and discussion

Figure 2 shows the correlations between heat produced and amount of ergosterol measured by GC-MSMS. It is seen that the trend is rather linear, but that there is an initial rapid increase that may be caused by the varying ergosterol contents of the inoculums.

Biological processes are complex and different methods to quantify the overall biological activity do not always correlate well. For example, the 1:1 relation between oxygen consumption and carbon dioxide production is true only under aerobic, stationary conditions [15].

The two techniques used in the present study have quite different properties as seen in the overview given in Table 1. Measurement of the unique fungal chemical marker ergosterol is an extremely specific, but destructive method that often gives a result related to the biomass. However, the direct correlation between biomass and ergosterol is complicated by that ergosterol is slowly degraded with time and that the formation of ergosterol is dependent on species and environmental conditions. Isothermal calorimetry is a non-destructive laboratory technique that monitors the heat production of a sample minute by minute and can thus be used as a convenient mean to quantify the effect of for example toxic substances on biological activity. Calorimetry is an extremely general technique and can, e.g., in a dust sample not differ between heat from moulds, house dust mites and condensation of water vapor. Calorimetry can only detect living fungi, whereas ergosterol determinations may be a way to assess previous fungal activity.

The combination of calorimetry and ergosterol determinations gives interesting possibilities. We have shown that the increase in amount of ergosterol is proportional to the developed heat, at least for rather young cultures. It has been shown that fungi can break down old parts of their hypha and use at the growth front [23]. This has been indicated also in relation to ergosterol measurements of decaying wood [24]. If this is the case the heat-ergosterol relation could break down in older samples unless the decreased ergosterol content is a result of lowered overall activity

As both the calorimetry and the ergosterol determination are quantitative, it is possible to calculate how much heat that is produced per formation of one gram of ergosterol. From the slope of the line in Fig. 2 we find that 0.11 μg ergosterol was produced for each joule of heat.

The present studies also give us information on the growth rate of fungi on a two-dimensional substrate. Figure 1 shows the thermal power for a representative sample measured during long

time drawn as a function of time. The same general behavior was found for all samples, indicating that the present type of calorimetric measurements can be used to test models of fungal growth by measuring the thermal power produced by samples growing on different substrates [25; 26].

Conclusions

We have shown that the ergosterol content of young fungal samples is proportional to the heat produced. The combination of two very different methods of quantifying fungal activity could further clarify aspects of fungal growth.

Acknowledgements

We acknowledge the support of FORMAS.

References

- [1] Prat H (1952) *Microcalorimetric studies on germinations of cereals. Can J Bot* 30:379-394.
- [2] Gram L, Sögaard H (1985) *Microcalorimetry as a rapid method for estimation of bacterial levels in ground meat. J Food Protect* 48:341-345.
- [3] Gustafsson L (1991) *Microbiological calorimetry. Thermochim Acta* 193:145-171.
- [4] Gustafsson L, Larsson C (1990) *Energy budgeting in studying the effect of environmental factors on the energy metabolism of yeasts. Thermochim Acta* 172:95-104.
- [5] Bjurman J, Wadsö L (2000) *Microcalorimetric measurements of metabolic activity of six decay fungi on spruce wood as a function of temperature. Mycologia* 92:23-28.
- [6] Wadsö L, Li Y, Bjurman J (2004) *Measurements on two mould fungi with a calorespirometric method. Thermochim Acta* 422:63-68.
- [7] Hansen LD, Smith BN, Criddle RS, Breidenbach RW (1998) *Calorimetry of plant respiration. J Thermal Anal* 51:757-763.
- [8] Wadsö L, Gomez F, Sjöholm I, Rocculi P (2004) *Effect of tissue wounding on the results from calorimetric measurements of vegetable respiration. Thermochim Acta* 422:89-93.
- [9] Lamprecht I, Seymour RS, Schultze-Motel P (1998) *Direct and indirect calorimetry of thermogenic flowers of the sacred lotus, Nelumbo nucifera. Thermochim Acta* 309:5-16.
- [10] Bäckman P (1992) *A microcalorimetric study of human erythrocytes in stirred buffer suspension. Thermochim Acta* 205:87-97.
- [11] Kemp RB (1991) *Calorimetric studies of heat flux in animal cells. Thermochim Acta* 193:253-267.
- [12] Schmolz E, Hoffmeister D, Lamprecht I (2002) *Calorimetric investigations on metabolic rates and thermoregulation of sleeping honeybees (Apis mellifera carnica). Thermochim Acta* 383:221-227.
- [13] Ginneken VJTv, Vanderschoot J, Addink ADF, Thillart GEEJMvd (1995) *Direct calorimetry of aquatic animals: dynamic response of biological processes. Thermochim Acta* 249:143-159.
- [14] Hansen LD, MacFarlane C, McKinnon N, Smith BN, Criddle RS (2004) *Use of calorespirometric ratios, heat per CO₂ and heat per O₂, to quantify metabolic paths and energetics of growing cells. Thermochim Acta* 422:55-61.

- [15] Gnaiger E, Kemp RB (1990) Anaerobic metabolism in aerobic mammalian cells: information from the ratio of calorimetric heat flux and respirometric oxygen flux. *Biochemica et Biophysica Acta* 1016:328-332.
- [16] Kemp RB (2000) "Fire burn and cauldron bubble" (W. Shakespear): what the calorimetric-respirometric (CR) ratio does for our understanding of cells? *Thermochim Acta* 355:115-124.
- [17] Seitz LM, Mohr HE, R B, Sauer DB (1977) Ergosterol as an indicator of fungal invasion in grains., *Cereal Chem* 54:1207-1217.
- [18] Newell SY (1992) Estimating fungal biomass and productivity in decomposing litter. In: *The Fungal Community, its Organization and Role in The Ecosystem, 2nd Edition* (Carroll GC, Wiclow DT, eds), pp 521-561. New York: Marcel Dekker Inc.
- [19] West AW, Grant WD (1987) Use of ergosterol, diaminopimelic acid and glucosamine contents of soils to monitor changes in microbial populations. *Soil Biol Biochem* 19:607-612.
- [20] Bjurman JIBaB (1994) Ergosterol as an indicator of mould growth on wood in relation to culture age, humidity stress and nutrient level. *Int Biodeterioration Biodegradation* 33:355-368.
- [21] Nout MJR, van Bonants TMG, Dejongh P, Dekoster PG (1987) Ergosterol content of *Rhizopus oligoporus* NRRL 5905 grown in liquid culture and solid substrates. *Appl Microbiol Biotechnol* 26:456-461.
- [22] Sebastian A, Larsson L (2003) Characterisation of the microbial community in indoor environments: a chemical-analytical approach. *Appl Environ Microbiol* 69:3103-3109.
- [23] Levi MP, Cowling EB (1969) Role of nitrogen in wood deterioration VIII. Physiological adaptation of wood-destroying and other fungi to substrates deficient in nitrogen. *Phytopathol* 59:460-468.
- [24] Bjurman J, Viitanen H (1996) Effect of wet storage on subsequent colonisation and decay by *Coniophora puteana* at different moisture contents. *Material und Organismen* 30:259-277.
- [25] Davidson FA (1998) Modelling the qualitative response of fungal mycelia to heterogeneous environments. *J Theor Biol* 195:281-292.
- [26] Davidson FA, Olsson S (2000) Translocation induced outgrowth of fungi in nutrient-free environments. *J Theor Biol* 205:73-84.

Figure Captions

Figure 1. The top figure shows the all measurements made for one sample for which measurements were continued for one month. The bottom figure shows the same data after linear interpolation and integration.

Figure 2. Measured total heats as a function of the time when the samples were removed from the calorimetric experiments and frozen.

Figure 3. The correlation between measured total heat and ergosterol content. The linear curve fit has been made for all measurements.

Figure 1

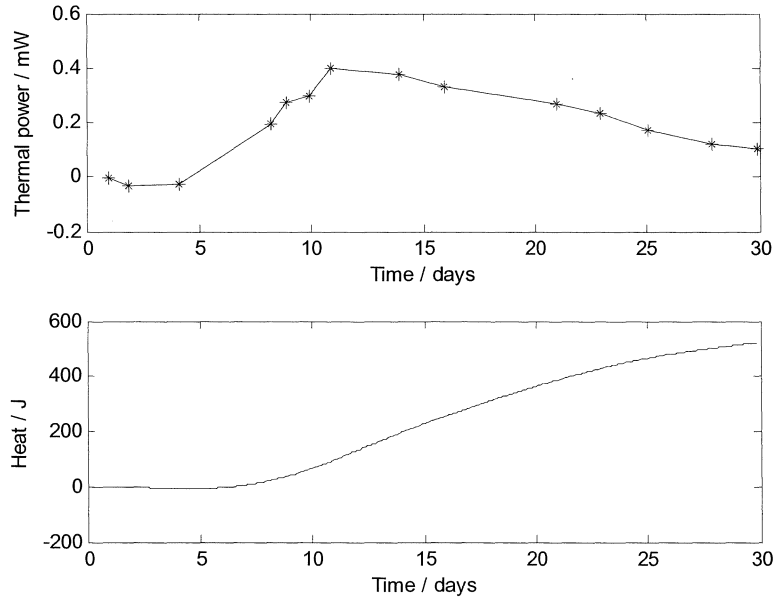

Figure 2

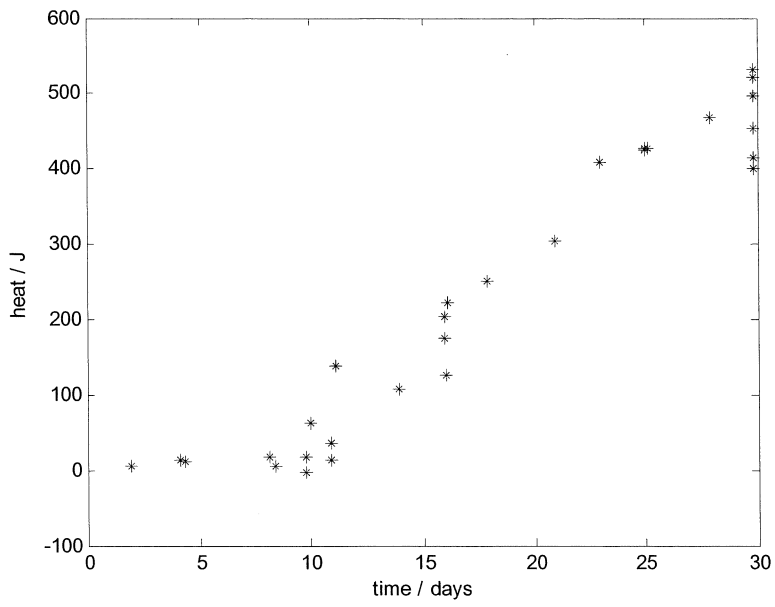
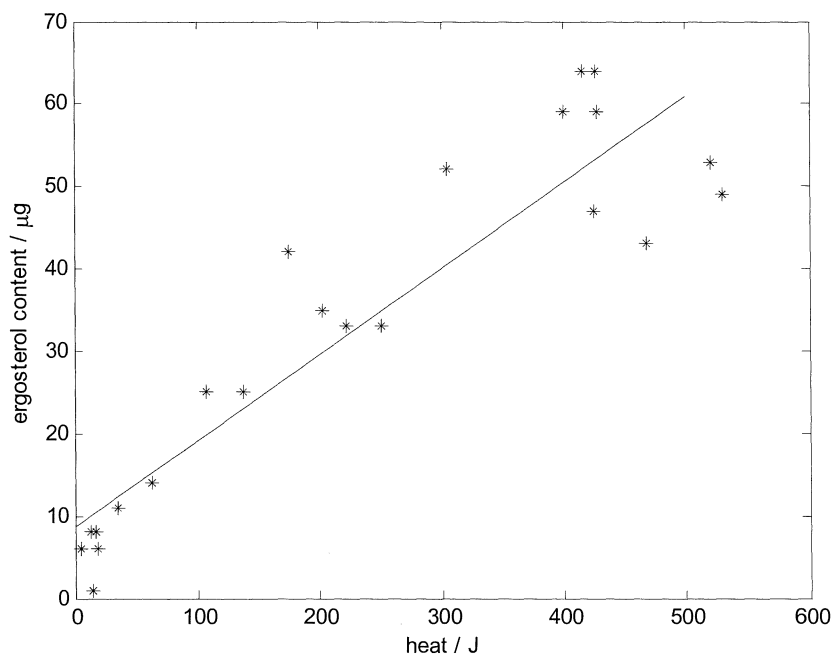

Figure 3



Tables

Table 1. Comparison between isothermal calorimetry and ergosterol quantification with respect to measurements of fungal activity.

	Isothermal calorimetry	Ergosterol quantification
Non-destructive	yes	no
Quantitative	yes	yes
Monitoring(1)	yes	no
Substrate independent	yes(2)	yes(3)
Fungal-specific	no	yes
Detects living fungi	yes	yes
Detects dead fungi	no	yes

(1) Continuous measurements can be made on a sample.

(2) The substrate itself must not produce heat.

(3) The substrate must not contain ergosterol (GC-MS-MS) or – depending on the specificity of the used analytical method – other sterols.



LUND
UNIVERSITY

KFS AB, Lund 2004