



LUND UNIVERSITY

Experimental demonstration of data erasure for time-domain optical memories

Dyke, T.R.; Sellars, M. J.; Pryde, G. J.; Manson, N. B.; Elman, U.; Kröll, Stefan

Published in:
Optical Society of America. Journal B: Optical Physics

1999

[Link to publication](#)

Citation for published version (APA):
Dyke, T. R., Sellars, M. J., Pryde, G. J., Manson, N. B., Elman, U., & Kröll, S. (1999). Experimental demonstration of data erasure for time-domain optical memories. *Optical Society of America. Journal B: Optical Physics*, 16(5), 805-811. <http://www.opticsinfobase.org/abstract.cfm?URI=josab-16-5-805>

Total number of authors:
6

General rights

Unless other specific re-use rights are stated the following general rights apply:
Copyright and moral rights for the publications made accessible in the public portal are retained by the authors and/or other copyright owners and it is a condition of accessing publications that users recognise and abide by the legal requirements associated with these rights.

- Users may download and print one copy of any publication from the public portal for the purpose of private study or research.
- You may not further distribute the material or use it for any profit-making activity or commercial gain
- You may freely distribute the URL identifying the publication in the public portal

Read more about Creative commons licenses: <https://creativecommons.org/licenses/>

Take down policy

If you believe that this document breaches copyright please contact us providing details, and we will remove access to the work immediately and investigate your claim.

LUND UNIVERSITY

PO Box 117
221 00 Lund
+46 46-222 00 00

Experimental demonstration of data erasure for time-domain optical memories

T. R. Dyke, M. J. Sellars, G. J. Pryde, and N. B. Manson

Laser Physics Centre, Research School of Physical Sciences and Engineering, Australian National University, Canberra, ACT, 0200, Australia

U. Elman and S. Kröll

Department of Physics, Lund Institute of Technology, S-221 00 Lund, Sweden

Received September 30, 1998; revised manuscript received January 19, 1999

Data erasure is considered an essential requirement for a practical optical time-domain memory, and it requires that the laser used have very good frequency stability. Such a laser is developed for this work, and data erasure is demonstrated with a sample of $\text{YSiO}_5:\text{Eu}^{3+}$ for write/rewrite pulse sequences of up to a duration of 100 μs . This is two orders of magnitude longer than had been achieved previously. Phase-sensitive detection is introduced and is shown to be invaluable for monitoring the write, rewrite, and read processes.

© 1999 Optical Society of America [S0740-3224(99)01305-3]

OCIS codes: 210.0210, 210.4680, 030.1670, 160.5690.

1. INTRODUCTION

Spectral hole-burning material has shown considerable promise for ultrahigh-storage-density optical memories,¹ and with currently available rare-earth-doped crystals it would be possible to store 10^7 bits of data at a single spatial location.^{2,3} In the simplest scheme, narrow spectral lines or holes are bleached from an inhomogeneously broadened absorption band, and the presence or the absence of absorption at a given frequency is used to store digital 1's and 0's.⁴ The writing and the reading of data require tuning a laser to specific frequencies and accessing bits one at a time. For rare-earth transitions where the linewidths can be <1 kHz, maintaining the maximum storage capacity would involve millisecond time for both the writing and the reading of an individual bit. Thus, although enormous storage densities are achievable, the slow speeds involved have negated the practicality of frequency-domain optical memories in rare-earth-ion-doped crystals.

Coherent time-domain data storage techniques as introduced by Mossberg⁵ can overcome the speed limitation. The storage again relies on the spectral hole-burning process, and the storage densities attainable are the same. However, in this case the data are stored by use of a series of rapid resonant light pulses. The short pulses excite ions over a range of frequencies, and pulses within the dephasing time of the optical transition interfere to give a spectral hole with a structure that is the Fourier transform of the applied data sequence. When the material containing the structured hole is excited by a single read pulse, stimulated echoes are generated, recreating the original pulse sequence.⁵ Therefore the pulse sequence is stored in the material by the hole-burning process. The significance of writing and reading with a series of pulses is that the information stored at a single

spatial location can be accessed within the millisecond dephasing time of the optical transition. There is the potential for enormous storage densities with data accessible at very high speeds, and these capabilities make the coherent time-domain optical memories attractive for the next generation of optical memories.^{6,7}

An additional capability of the time-domain technique, which is essential if the memories are to have widespread usage, is the ability to modify the stored data. The additional process required for this is the ability to erase single data bits once stored. Erasure can be achieved, as pointed out by Akhmediev,⁸ by rewriting the original data with a phase shift of 180° . Since the phase of the echo is determined by the relative phase of the data pulse and the write pulse, echoes prepared once in phase and once out of phase will destructively interfere, canceling each other. Thus data bits can be selectively erased. The subject of the current paper is to demonstrate the significantly improved performance of erasure in comparison with earlier work.

Erasure has been demonstrated previously, but as the process requires good laser stability, the erasure has been achieved only on very restricted time scales. The first demonstration⁹ involved a pulsed-laser study of a Na optical transition on a time scale of 20 ns. The phase stability between the pulses is achieved by generation of all the pulses from a single laser pulse. The beam is split to give the various pulses and is recombined at the sample with the required delays. More recent studies have used cw lasers with rare-earth ions in crystals and have obtained good erasure in the microsecond time regime. The accessible time was restricted by the laser stability, and a full analysis was made of how the laser frequency jitter affected the erasure efficiency.¹⁰

In this paper we show that it is possible both to stabi-

lize a tunable dye laser using standard methods and to obtain satisfactory modification of the stored data over the total time period accessible with present materials. The restrictions on the frequency and the phase stability of the laser are severe, and errors in the data will occur if the right conditions are not met. Therefore, it is imperative that the processes be monitored, and for this we introduce phase-sensitive detection so that any incorrect processing that is due to inadequate laser performance can be identified. The individual steps involved in writing and reading the optical memories are presented in detail. A procedure is designed to highlight the fundamentals of the processes involved and to show the value of a phase-sensitive detection scheme for the measurement of the stimulated echoes.

2. EXPERIMENT

Measurements were made with the ${}^5D_0-{}^7F_0$ transition of Eu^{3+} in a 0.1%-doped crystal of Y_2SiO_5 crystal at liquid-helium temperatures. There are two rare-earth sites, and the laser was tuned to be resonant with the transition corresponding to site 1 at 579.9 nm.^{2,3} The line has an inhomogeneous linewidth of 5 GHz and a homogeneous linewidth determined from the time-domain dephasing time measurements of 210 Hz.² The maximum storage capability is given by the ratio of these linewidths and equals 2.4×10^7 . In the time domain this would be achieved with a data sequence of 60-ps pulses emitted over the duration of the dephasing time of 1.5 ms (2.6 ms with an applied magnetic field). The dephasing time of the material is the longest reported for a transition in a solid² and means long data sequences can be stored. In practice the dephasing may be shortened by an increased temperature, higher rare-earth concentrations, and light-induced spectral diffusion,¹¹ and here

with a 5–10-mW beam focused to a 100- μm spot on the sample the dephasing time is reduced to $\sim 150\text{--}200 \mu\text{s}$.

The laser used for the experiments was a modified Coherent 699-21, as described in an earlier publication.¹² The laser was locked to an external reference cavity with a phase-modulation technique,¹³ and the low-frequency error signals controlled the Coherent Brewster plate and the mirror mounted on a piezoelectric transducer. The higher-frequency error signals were applied to a Gsanger phase modulator mounted within the cavity. The peak-to-peak frequency fluctuations given by the error signal indicated that the laser and the reference cavities were locked to better than 100 Hz, and as a result of the excellent relative stability, the system characteristics relevant to the present experiments were those determined solely by the reference cavity. The reference cavity consisted of a 50-cm-long Fabry-Perot with mirrors mounted on a ceramic Zero-dur tube. Vibrational isolation provides good short-term (<100 Hz in 1 ms) stability, and temperature control restricted long-term shifts in frequency to less than 100 kHz. Within these limits the drift rate of the reference cavity is found to be of the order of 10 kHz/s, and it is this drift rate that placed a restriction on the demonstration of data erasure. If 90% data erasure is to be achieved for data bits at long delays of, say, 100 μs , the laser cannot be allowed to drift more than 1 kHz between the write and the modify pulse sequences. Similarly, if we wish to demonstrate detection with reasonable phase stability, the drift over the duration of the write/modify/read cycle has likewise to be less than 1 kHz. Therefore, the drift rate of the reference cavity restricts our experiments to be completed within 100 ms.

A schematic of the equipment is shown in Fig. 1. A beam splitter is used to reflect 5% of the light for use as a reference beam or local oscillator for the phase-sensitive detection. The more intense beam is gated by two acousto-optic modulators operating at 90 MHz and 80

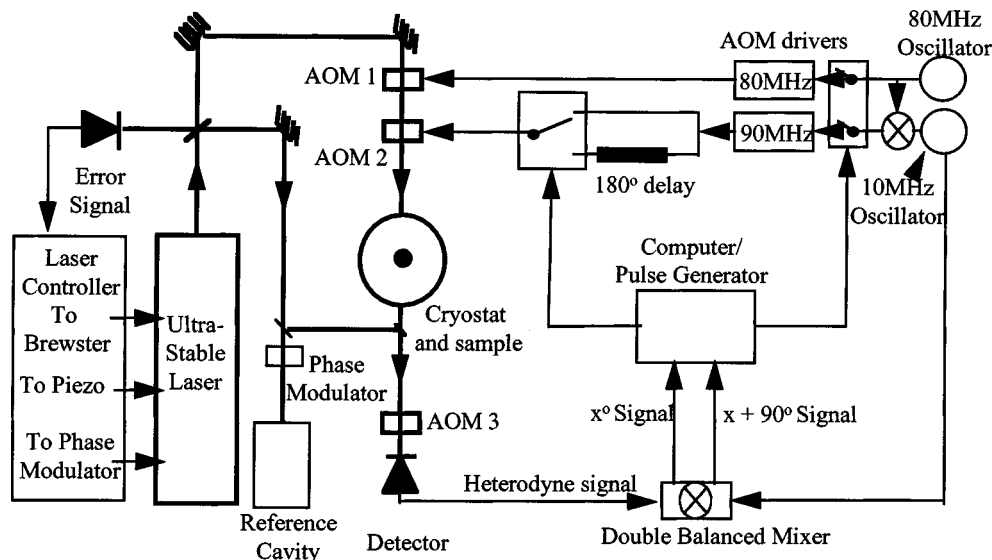

Fig. 1. Schematic of experimental apparatus. The laser is shown on the left and is locked to a stabilized reference cavity. The beam is gated by two acousto-optic modulators (AOM 1 and AOM 2). The two modulators also shift the frequency by 10 MHz, the transmitted light is overlapped with a weak beam ($\sim 1\%$) direct from the laser, and the transmitted light or the echo can be detected as a heterodyne beat signal. This 10-MHz signal is detected with phase-sensitive detection by use of a dual double-balanced mixer. Two orthogonal phases are measured, and a reference pulse is used to determine 0° phase.

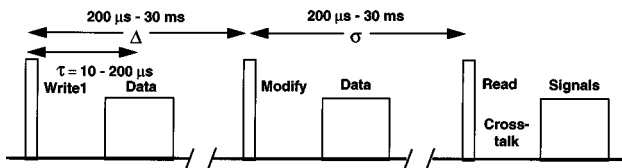

Fig. 2. Definitions of pulse sequences used in the experiments. There are three separate groups of pulses denoted as write 1, modify (or write 2), and read, and each is initiated by a single reference pulse. After the reference pulse the data sequence is completed on a time scale of $\tau \sim T_2 \sim 200 \mu\text{s}$. The delays between the reference pulses are greater than T_2 but less than 30 ms. The latter restriction is due to the residual laser drift.

MHz. The frequency of the beam reaching the sample is thus shifted by 10 MHz, and so when recombined with the unshifted local oscillator on the detector gives a heterodyne beat at 10 MHz, giving a detection scheme very similar to that used by Muramoto *et al.*¹⁴ To protect the photodiode, there is a further acousto-optic modulator providing attenuation for the duration of the preparation pulses. When this acousto-optic modulator is switched on, after the read pulse a transient can be seen in the experimental traces and marks the change in gain but otherwise has little significance. The stimulated echoes are detected as a 10-MHz beat, and this signal is combined in a dual double-balanced mixer with the 10-MHz frequency associated with the difference between the two acousto-optic modulator driving fields. Two orthogonal outputs of the mixer provide the phase-sensitive detection of the stimulated echo. These two orthogonal phases are measured and combined to determine the in-phase and the quadrature signals with the reference light pulses used to define the phases. The rf gating of the acousto-optic modulators for the read, write, and data pulses is controlled by a computer, and shifting the phase of the light is affected by phase changes in the driving rf. The computer is also used for data acquisition.

There are three stages involved with the optical memory: writing, modifying, and reading (Fig. 2). Each stage involves a time of the order of the dephasing time T_2 , whereas they are separated by a time Δ between the writing and the modifying processes and σ between the modify and the read processes, with both the later separations being longer than T_2 . The current restrictions imposed by the laser drift limit the total duration of the write/rewrite/read cycle to 100 ms, and thus Δ and σ were varied within the range $200 \mu\text{s}$ to 30 ms. For the shorter times, part of the population storage is associated with the excited state, whereas for the longer time ($>T_1 = 1.9 \text{ ms}$) the storage involves a redistribution of population in the ground-state hyperfine levels. The signals are detected in a single shot. Then after zero phase is determined, five shots are added to give the traces displayed in the figures. A good signal-to-noise ratio is obtained throughout with some variation from minor changes in alignment and laser intensity. The restriction owing to the hole-burning lifetime for $\text{YSiO}_5:\text{Eu}^{3+}$ is many hours³ and many orders of magnitude longer than the times used in the present experiment.

Two pulse photon echoes are strongest when the pulse areas are of the order of $\pi/2$; in the present experiment this would involve a pulse duration of $10 \mu\text{s}$. Here $3\text{-}\mu\text{s}$

pulses were preferred, to enable operation in the linear regime and avoid any saturation effects. Also with such pulse lengths there should be no complication in the echo shape or the oscillations in the decay from hyperfine effects, as the hyperfine separations³ are all much larger than the Fourier width of the pulses. The signals, however, were sufficient to obtain a stimulated echo with delays up to $100 \mu\text{s}$ with a signal-to-noise ratio better than 10:1. A summary of the parameters used in data processing is given in Fig. 2. For each demonstration the laser is held fixed in frequency but is then shifted by 300 MHz for the following demonstration. This procedure ensured that each demonstration utilized a region of the absorption spectrum that had not been previously modified by spectral hole burning.

3. DATA STORAGE AND ERASURE

A single data bit can be stored by applying a write pulse followed after a delay by a single data pulse. This is illustrated. Bit (A) is stored by application of the pulse sequence shown in the top of Fig. 3(a). There is a reference

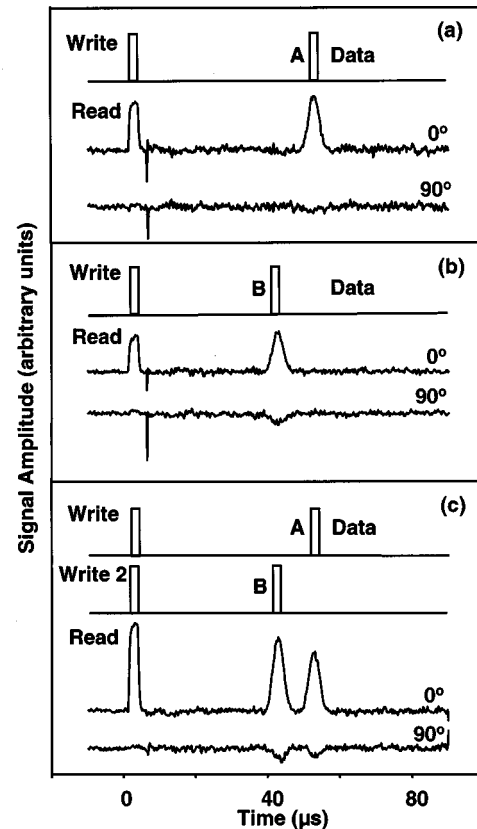

Fig. 3. Illustration of bit-by-bit storage. A schematic of write pulses is shown together with experimental measurement of subsequent stimulated photon echo detected with phase-sensitive techniques. The signals are detected in orthogonal phases and presented with respect to the read pulse. Each pulse is $3 \mu\text{s}$ wide. The sharp line immediately after the read pulse is due to gating of the attenuating acousto-optic modulator and indicates a gain change of 20. The sequences correspond to the following: (a) (A) only, $\tau_A = 50 \mu\text{s}$; (b) (B) only, $\tau_B = 40 \mu\text{s}$; and (c) (A) + (B) in a two-step write process. The delay between write and read pulses is $\sigma = 200 \mu\text{s}$, and between write 1 and write 2 it is $\Delta = 200 \mu\text{s}$.

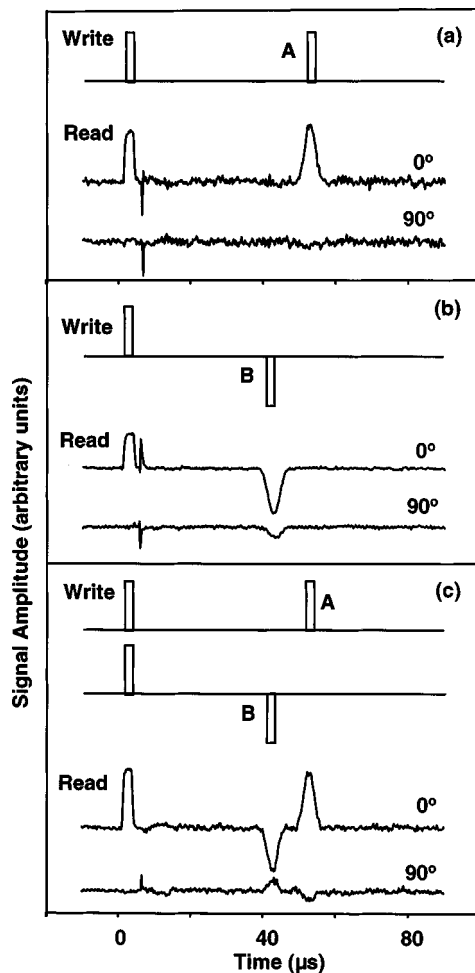

Fig. 4. Illustration of bit-by-bit storage with positive and negative pulses. A schematic of write pulses is shown together with stimulated photon echo similar to Fig. 1. The sequences correspond to the following: (a) (A) only, $\tau_A = 50 \mu\text{s}$; (b) $(-B)$ only, $\tau_B = 40 \mu\text{s}$; and (c) $(A) + (-B)$ in a two-step write process.

or a write pulse followed after a delay of $\tau_A = 50 \mu\text{s}$ by a single data pulse. The data are read after a time σ (selected to be $200 \mu\text{s}$) and is achieved by monitoring the stimulated-echo signal following a read pulse [Fig. 3(a)]. There is a clear echo at the corresponding delay τ_A , and the echo signal is in-phase with the read pulse. The minor responses in quadrature indicate acceptable laser stability and are discussed below. The procedure is repeated for a (B) bit where the only change is the delay after the write pulse is changed to $\tau_B = 40 \mu\text{s}$. This is shown in Fig. 3(b), where a clear in-phase echo with a delay of τ_B can be seen. These two data (A) and (B) bits are stored with the laser at two separate optical frequencies. If the data bit (B) is added to data bit (A), achieved with the laser at the same frequency, the full pulse sequence is as indicated at the top of Fig. 3(c). A write sequence to store (A) is followed by a delay Δ that can be any length longer than the dephasing time (here, $\Delta = 200 \mu\text{s}$), and then the (B) write sequence is applied. In this way (B) is added to (A) at the same frequency and spatial location. The information stored is read with a single reference

pulse as shown in the experimental trace in Fig. 3(c). $(A+B)$ is detected with both the echoes of in-phase with the read pulse.

With phase-sensitive techniques the data pulses can have a negative sign; this aspect is shown in Fig. 4, where we follow the same procedures as for Fig. 3 except that the sign of one of the pulses is reversed. This is achieved by changing the phase of the acousto-optic driving field between the reference pulse and the data B. The single data bits are stored but this time with alternate sign. The (A) pulse is positive but the (B) pulse is negative [Figs. 4(a) and 4(b)]. By applying both write sequences in series at the same frequency, we can also add the two data bits as shown in Fig. 4(c). The two echoes are detected, one positive and one negative.

The above illustrations are invaluable for understanding the procedure for erasing data bits, as it can be readily anticipated that, if two data bits with the same delay, one positive and one negative, were superimposed, they would cancel. This situation is demonstrated in Fig. 5. Initially (A) and (B) are stored at a fixed frequency and the same location by the two-step process as given in Fig. 3(c). Reading the data gives $(A+B)$ [Fig. 5(a)]. The third write sequence adds a $(-B)$ pulse to $(B+A)$. This erases (B). Erasure is confirmed by application of a read pulse, and a single (A) echo is obtained [Fig. 5(b)]. There is near-complete erasure, as there are only minor features remaining at a delay of $40 \mu\text{s}$.

When the data sequence contains more than one data bit there is a slight complication in that extra echoes are

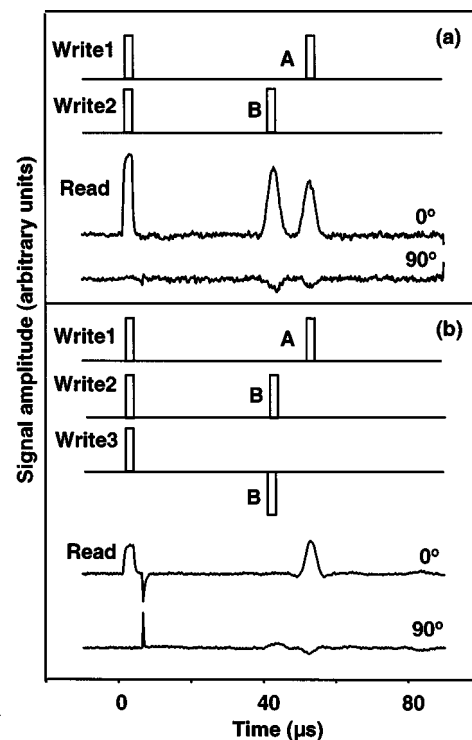

Fig. 5. Demonstration of data erasure, $[(A) + (B)] + (-B) = A$. Upper schematics give write sequences, and lower traces give experimental measurements of subsequent echoes with phase-sensitive detection: (a) $(A) + (B)$ in a two-step write process; (b) a $(-B)$ write sequence is added to the above sequence, and measurement shows B is erased.

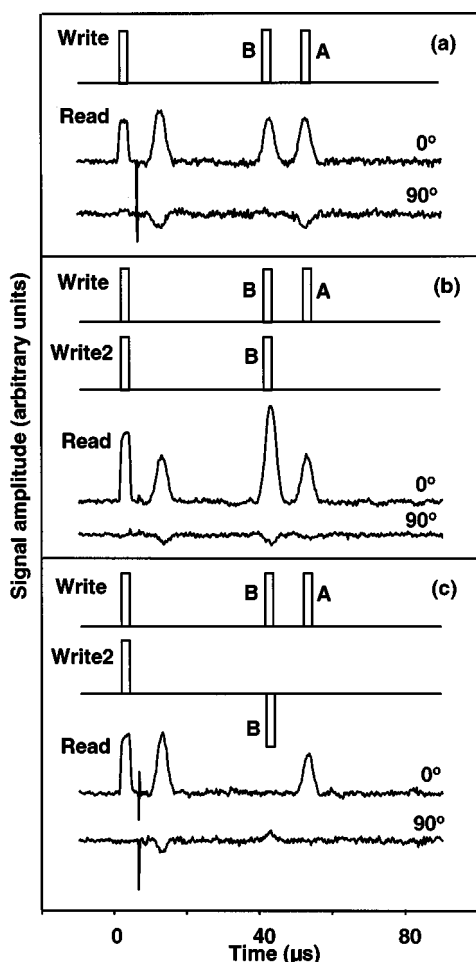

Fig. 6. Demonstration of enforcing, $(A + B) + (B) = A + 2B$, and data erasure, $(A + B) + (-B) = A$. (a) $(A + B)$ is written in a single write sequence. The echo at $10 \mu s$ is the cross-talk echo between two data bits. (b) The effect of adding (B) to the above memory. The same echoes are obtained except B is increased in size. (c) Data erasure by adding a negative $(-B)$ pulse to the memory as stored in (a).

generated. The desired echoes arise from interference between the write pulse and the data pulses, but extra echoes are generated from the interference between the data pulses themselves. These are termed cross-talk echoes. It is appreciated that cross talk can be avoided by use of different propagation directions for the reference and the data pulses¹⁵, however, this necessitates precise overlap of the beams in the sample and can make phase-sensitive detection difficult to achieve. A simpler way to avoid confusion between data echoes and cross-talk echoes is to introduce a significant delay between the write pulse and all data pulses. Then the stimulated data echoes are similarly delayed, whereas the cross-talk echoes occur immediately after the read pulse. In this way some simple time restrictions can be used to identify the appropriate stimulated echoes. These characteristics are clearly illustrated in Fig. 6. Two data bits are stored in a single write sequence by application of a write pulse followed by a considerable delay by the two data pulses ($A + B$) with delays of $\tau_A = 50 \mu s$ and $\tau_B = 40 \mu s$ and separation $10 \mu s$. The stimulated echo generated gives the two echoes with delays corresponding to $(A + B)$. In ad-

dition there is a corresponding cross-talk echo of $10 \mu s$ after the read pulse. These echoes occurring close to the read pulse are immediately recognized as cross-talk pulses and can be neglected.

The procedure for modifying the stored information is the same as before. For example, a data bit can be reinforced or erased by addition of a positive or a negative data pulse. In Fig. 6(b), (B) is added to the previously stored $(A + B)$. It is seen that the (B) pulse is reinforced (increased in size). Alternatively, by introduction of a phase change in Fig. 6(c), $(-B)$ is added, and this erases the previously stored (B) pulse. All the echoes are in phase with the read pulses, and there is very little signal in the quadrature phase or, in the case of an erased data, in either phase.

In a practical memory there will be a series of data bits following the reference pulse, and after a delay it should be possible to change the stored information. The requirements for the laser stability are more strict the longer the delays between the writing and reading processes are and the longer the pulse sequence is. In the above examples the delays between processing are quite short, $\Delta = \sigma = 200 \mu s$. With the present laser this could be extended to many milliseconds without significant deterioration in performance. For example, Fig. 7 gives an illustration of erasing and reinforcing a data bit with de-

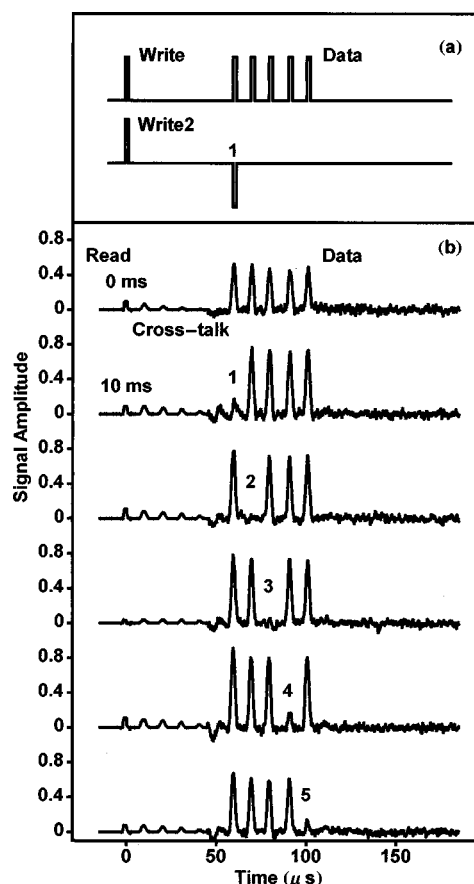

Fig. 7. Demonstration of data erasure from a five-pulse data sequence with 10-ms processing delays, Δ and σ . The schematics indicate the pulse sequence used for writing and subsequently erasing data bit 1. This procedure is repeated for data bits 2-5, and the experimental traces show the resultant stimulated echoes where one bit is erased.

lays $\Delta = \sigma = 10$ ms. Five data bits are stored with delays between 50 and 100 μ s, and it is shown that with delays of 10 ms any one of these data bits can be erased with only minor residual echoes. There is little information in the orthogonal phase, and for brevity this phase is not shown. The cross-talk echoes are significant, particularly with regularly spaced data pulses giving cross-talk features at the same delay. However, with data delays between 50 μ s and 100 μ s, all the cross-talk signals occur before the first data pulse and can be minimized by use of reduced gain. Somewhat longer delays could be used in the present demonstration without significant deterioration of performance, but when the total duration of the experiment was longer than 100 ms, erasure was no longer reliable. This would require some improvement in the reference cavity.

4. DISCUSSION

In the above experiments small signals are detected in quadrature, and there are also some residual signals after data erasure, particularly with the long delays. These signals arise from a change of the laser frequency, and the magnitude of the frequency changes can be estimated from the size of the weak signals. The quadrature signals vary rapidly with phase and provide a sensitive probe of the change of phase. For example, a $2\pi/20$ phase change gives a quadrature signal $0.1\times$ the in-phase signal, and the 50- μ s delays correspond to frequency shifts of 1 kHz. The experiments shown indicate that the drifts are <1 kHz. The quadrature signals are larger for longer delays of the order of 100 ms and imply that there is a drift rate of the order of 10 kHz/s.

The drift rates of the system are solely attributed to the reference cavity, and with an improved reference cavity the characteristic of the complete system could also be improved. This is not unrealistic, as there have been reports of reference cavities with stabilities that are orders of magnitude better than that reported here^{13,16} or indeed orders of magnitude better than required for hole-burning memories. An alternative approach is to use the echo signals themselves to determine the frequency drifts and to use this information to introduce the necessary correction or to generate the necessary signals.¹⁰

In our experiment we have control over the amplitude, the frequency, and the relative phase of the light pulses reaching the sample, and therefore it is possible to use not only phase-shifted data pulses for data erasure but also amplitude- and phase-modulated reference pulses. Identical write, rewrite, and read reference pulses must always be used, but provided this is done (and it is readily achievable) the data pulses can be correctly recalled including any phase information. Such controlled reference pulses are of value when only modest laser power is available. The data pulses can be made short to gain bandwidth, whereas the reference can be longer with phase¹⁷ or amplitude and can be phase¹⁸ varied to retain the same bandwidth as the data pulses. The longer pulses give stronger data echoes, which are then distinguishable from the cross-talk echoes. Therefore, our

present developments are fully consistent with the proposed use^{17,18} of such amplitude- and phase-modulated reference pulses.

Complimentary to data erasure is data reinforcement, and significantly stronger echoes can be obtained by re-writing of the data multiple times.¹⁹ Rewriting the data can also be invaluable in retaining the memory beyond the hole-burning lifetime. Averaging can also be used in data recall. With phase-sensitive detection the in-phase signal will improve, whereas the quadrature signal should average to zero such that a nonzero quadrature signal could then be used as a check of the reliability of the memory.

5. CONCLUSIONS

Reliable and repeatable data erasure has been demonstrated for data pulse sequences that have durations comparable to T_2 and approach the longest achievable with a solid-state material. This has been attained with the use of an ultrastable tunable ring dye laser developed with careful but conventional techniques. There is full control of the amplitude, the frequency, and the phase of the light, and signals are detected with phase-sensitive techniques. Combining these features has enabled us to demonstrate the fundamental process associated with time-domain optical memory. Data bits were written and recalled with predetermined phases and then erased, reinforced, or read out, showing full control over their optical storage. With some further improvement in the frequency stability of the reference, the work indicates the approach that should be taken for a fully flexible time-domain optical memory.

ACKNOWLEDGMENTS

S. Kröll and U. Elman thank the Australian Department of Industry, Science and Technology for the award of a Bilateral Science and Technology grant that assisted in supporting them for part of this work.

REFERENCES

1. W. E. Moerner, *Persistent Spectral Hole-Burning: Science and Applications* (Springer, New York, 1988).
2. R. W. Equal, Y. Sun, R. L. Cone, and R. M. Macfarlane, "Ultralow optical dephasing in $\text{Eu}^{3+}:\text{Y}_2\text{SiO}_5$," *Phys. Rev. Lett.* **72**, 2179–2182 (1994); R. L. Cone, R. W. Equal, Y. Sun, R. M. Macfarlane, and R. Hutchenson, "Ultralow dephasing and dephasing mechanisms in rare earth materials for optical data storage," *Laser Phys.* **5**, 573–575 (1995).
3. R. Yano, M. Mitsunaga, and N. Uesugi, "Ultralong optical dephasing time in $\text{Eu}^{3+}:\text{Y}_2\text{SiO}_5$," *Opt. Lett.* **16**, 1884–1892 (1991); R. Yano, M. Mitsunaga, and N. Uesugi, "Nonlinear laser spectroscopy of $\text{Eu}^{3+}:\text{Y}_2\text{SiO}_5$ and its application to time-domain optical memory," *J. Opt. Soc. Am. B* **9**, 992–997 (1992).
4. A. Szabo, "Frequency selective optical memory," U.S. patent 3,896,420 (July 22, 1975); G. Castro, D. Haarer, R. M. Macfarlane, and H. P. Trommsdorff, "Frequency selective optical data storage," U.S. patent 4,101,976 (July 18, 1978).
5. T. W. Mossberg, "Time domain frequency-selective optical data storage," *Opt. Lett.* **7**, 77–79 (1982).
6. W. R. Babbitt and T. W. Mossberg, "Time-domain frequency-selective optical data storage in a solid-state ma-

- terial," *Opt. Commun.* **65**, 185–188 (1988); W. R. Babbitt and T. W. Mossberg, "Quasi-two-dimensional time-domain color memories: process limitations and potentials," *J. Opt. Soc. Am. B* **11**, 1948–1953 (1994).
7. S. Kröll and P. Tidlund, "Recording density limit of photon-echo optical storage with high-speed writing and reading," *Appl. Opt.* **32**, 7233–7242 (1993).
 8. N. N. Akhmediev, "Information erasing in the phenomenon of long lived photon echo," *Opt. Lett.* **15**, 1035–1037 (1990).
 9. M. Arend, E. Block, and S. R. Hartmann, "Random access processing of optical memory use of photon-echo interference effects," *Opt. Lett.* **18**, 1789–1791 (1993).
 10. U. Elman, B. Luo, and S. Kröll, "Influence of laser phase and frequency fluctuations on photon-echo data erasure," *J. Opt. Soc. Am. B* **13**, 1905–1914 (1996).
 11. J. Huang, J. M. Zhang, A. Lezama, and T. W. Mossberg, "Excess dephasing in photon-echo experiments arising from excitation-induced electronic level shifts," *Phys. Rev. Lett.* **63**, 78–81 (1989); J. Huang, J. M. Zhang, and T. W. Mossberg, "Excitation-induced frequency shifts and frequency-dependent dephasing in $\text{Eu}^{3+}:\text{Y}_2\text{O}_3$," *Opt. Commun.* **75**, 29–32 (1990); S. Kröll, E. Y. Xu, M. K. Kim, M. Mitsunaga, and R. Kachru, "Intensity-dependent photon-echo relaxation in rare-earth-doped crystals," *Phys. Rev. B* **41**, 11568–11571 (1990); S. Kröll, E. Y. Xu, and R. Kachru, "Influence of excited-state Pr^{3+} on the relaxation of the $\text{Pr}^{3+}:\text{YAlO}_3$ $^3H_4-^1D_2$ transition," *Phys. Rev. B* **44**, 30–34 (1991); G. K. Liu and R. L. Cone, "Laser-induced instantaneous spectral diffusion in Tb^{3+} compounds as observed by photon-echo experiments," *Phys. Rev. B* **41**, 6193–6200 (1990); M. Mitsunaga, T. Takagahara, R. Yano, and N. Uesugi, "Excitation-induced frequency shift probed by stimulated photon echoes," *Phys. Rev. Lett.* **68**, 3216–3219 (1992); X. A. Shen and R. Kachru, "Optimization of time-domain storage density in the presence of excitation-induced spectral diffusion," *Appl. Opt.* **36**, 6692–6695 (1997).
 12. M. J. Sellars, R. S. Meltzer, P. T. H. Fisk, and N. B. Manson, "Time-resolved ultranarrow optical hole burning of a crystalline solid: $\text{Y}_2\text{O}_3:\text{Eu}^{3+}$," *J. Opt. Soc. Am. B* **11**, 1468–1473 (1994).
 13. R. W. Drever, J. L. Hall, F. V. Kowalski, J. Hough, G. M. Ford, A. J. Munley, and H. Ward, "Laser phase and frequency stabilization using an optical resonator," *Appl. Phys. B: Photophys. Laser Chem.* **31**, 97–105 (1983).
 14. T. Muramoto, S. Nakanishi, T. Endo, and T. Hashi, "Studies of phase characteristics of various photon echoes with a phase sensitive detection method," *Opt. Commun.* **36**, 409–414 (1981).
 15. M. Fujita, H. Nakatsuka, H. Nakanishi, and M. Matsuoka, "Backward echo in two-level systems," *Phys. Rev. Lett.* **42**, 974–977 (1979); W. H. Hesselink and D. A. Wiersma, "Picosecond photon echoes stimulated from an accumulated grating," *Phys. Rev. Lett.* **43**, 1991–1994 (1979).
 16. J. Dirscherl, B. Neizert, T. Wegener, and H. Walther, "A dye laser spectrometer for high resolution spectroscopy," *Opt. Commun.* **91**, 131–139 (1992); N. M. Sampas, E. K. Gustafson, and R. L. Byer, "Long-term stability of two diode-laser-pumped nonplanar ring laser independently stabilized to two Fabry-Perot interferometers," *Opt. Lett.* **18**, 947–949 (1993); A. N. Luiten, A. G. Mann, M. E. Costa, and D. G. Blair, "Power stabilized cryogenic sapphire oscillator," *IEEE Trans. Instrum. Meas.* **44**, 132–135 (1995); S. Seel, R. Storz, G. Ruoso, J. Mlynec, and S. Schiller, "Cryogenic optical resonators: a new tool for frequency stabilization at the 1-Hz level," *Phys. Rev. Lett.* **78**, 4741–4744 (1997).
 17. J. M. Zhang, D. J. Gauthier, J. Huang, and T. W. Mossberg, "Use of phase-noisy laser fields in the storage of optical pulse shapes in inhomogeneously broadened absorbers," *Opt. Lett.* **16**, 103–105 (1991); X. A. Shen, Y. S. Bai, and R. Kachru, "Reprogrammable optical matched filter for biphas-coded pulse compression," *Opt. Lett.* **17**, 1079–1081 (1992); X. A. Shen and R. Kachru, "Use of biphas-coded pulses for wideband data storage in time-domain optical memories," *Appl. Opt.* **32**, 3149–3151 (1993); Y. S. Bai and R. Kachru, "Coherent time-domain data storage with spread spectrum generated by random biphas shifting," *Opt. Lett.* **17**, 1189–1191 (1993).
 18. X. A. Shen, R. Hartman, and R. Kachru, "Impulse-equivalent time domain optical memory," *Opt. Lett.* **21**, 833–835 (1996); X. A. Shen and R. Kachru, "Experimental demonstration of impulse-equivalent time domain optical memory," *Opt. Lett.* **21**, 2020–2022 (1996).
 19. M. J. Sellars, T. R. Dyke, G. J. Pryde, and N. B. Manson, "Time-domain optical memories using rare earth ions," *Mater. Sci. Forum* (to be published).