



LUND UNIVERSITY

The locus of case and agreement

Sigurðsson, Halldor Armann

2000

[Link to publication](#)

Citation for published version (APA):

Sigurðsson, H. A. (2000). *The locus of case and agreement*. (Working Papers in Scandinavian Syntax; Vol. 65). Department of Scandinavian Languages, Lund University.

Total number of authors:

1

General rights

Unless other specific re-use rights are stated the following general rights apply:

Copyright and moral rights for the publications made accessible in the public portal are retained by the authors and/or other copyright owners and it is a condition of accessing publications that users recognise and abide by the legal requirements associated with these rights.

- Users may download and print one copy of any publication from the public portal for the purpose of private study or research.
- You may not further distribute the material or use it for any profit-making activity or commercial gain
- You may freely distribute the URL identifying the publication in the public portal

Read more about Creative commons licenses: <https://creativecommons.org/licenses/>

Take down policy

If you believe that this document breaches copyright please contact us providing details, and we will remove access to the work immediately and investigate your claim.

LUND UNIVERSITY

PO Box 117
221 00 Lund
+46 46-222 00 00

THE LOCUS OF CASE AND AGREEMENT

Halldór Ármann Sigurðsson
University of Iceland/University of Lund

Structural case-marking has long been one of the most central concerns of generative syntax theory.¹ A widely accepted view is that nominative case-marking takes place outside of VP and hence interacts with both verb inflection and subject placement external to VP (NP-movement).² Accusative case-marking is often assumed to take place outside of VP as well, in a Spec,AgroP position.

In this paper, I shall argue that structural case-marking (or case-matching) takes place vP-internally. On this radically minimalistic view the locus of both nominative and accusative is v*/v (the light verb of Chomsky 1995, 1998, 1999), that is to say, v* or v matches nominative case directly, whereas v* activates V as an accusative matcher.³

My reasons for claiming that structural case-marking is vP-internal are both empirical and conceptual. The empirical arguments stem primarily from

¹ The ideas pursued in this paper have been presented (to a varying degree) at several occasions and places: At the 22nd Annual Meeting of the German Linguistic Society, in Marburg, March 2000, the 18th Scandinavian Conference of Linguistics, in Lund, May 2000, the NorFA Course on Morphology, in Tartu, June 2000, at the Scandinavian Language Department, University of Lund, May 5 2000, the Linguistic Department, University of Salzburg, June 6 2000, and at the Linguistic Department, University of Stuttgart, June 8 2000. I thank the instigators and organizers of all these events, in particular Ellen Brandner, Hubert Haider, Gunnar Hrafn Hrafnbjargarson, Sten Vikner, Jussi Niemi and my colleagues in Lund. For valuable comments and discussions, I am indebted to a lot of friends and colleagues. In alphabetic order by first names: Anders Holmberg, Cecilia Falk, Christer Platzack, Ellen Brandner, Gunlög Josepsson, Hubert Haider, Ian Roberts, Jóhanna Barðdal, Jóhannes Gísli Jónsson, Josef Beyer, Lars-Olof Delsing, Peter Svenonius, Sten Vikner, Stephen Anderson, Thórhallur Eythórsson, Ute Bohnacker, Verner Egerland. Thank you all. Finally, many thanks to Christer Platzack for his editing comments and help.

² For early arguments against NP-movement being case-driven, within the generative tradition, see for instance Sigurðsson 1989, 1991, 1992, where it is nonetheless assumed that nominative case is assigned by Infl.

³ I assume that case is matched, thus departing from Chomsky's approach. In his view "Case itself is not matched, but deletes under matching of ϕ -features" (1999, p. 4).

Icelandic case-agreement facts, some of which have become widely known in the minimalistic literature over the last few years (cf. Chomsky 1999 and many others). The conceptual arguments are partly based on the Earliness Principle (cf. Chomsky 1999, p. 12): relations such as case-matching should be as local and take place as soon in the derivation as possible.

The paper is organized as follows. In section 1, I sketch Chomsky's Phase Approach to structural case-marking, under which the locus of nominative and accusative are T and V (or, alternatively, T and v^* , the "strong" light verb). In section 2, I present the central facts of Icelandic structural case-marking and develop a vP-internal case-marking approach that accounts neatly for the observed facts. It follows that DP-displacement (NP-movement) cannot possibly relate to case-marking, and, second, that the locus of agreement is not the same as that of case. Sections 3-5 present data that support these conclusions. In section 3, I discuss multiple subject positions in Scandinavian languages, indicating that DP-displacement is to a large extent "semantically" or informationally driven. Section 4 presents a new analysis of Icelandic finite verb agreement, based on the assumption that there are specific Num(ber) and Pers(on) heads, distinct from T. Section 5 presents further evidence that structural case is vP-internal, thus underpinning the divorce of agreement and case, argued for in sections 2-4.

The need for specific Num and Pers heads indicates that even fusional languages like Icelandic opt for *distributed heading* rather than *compact heading*, suggesting that distributed heading is a fundamental property of UG. In the concluding section, I shall propose that there is one-to-one mapping of formal features and functional heads, a step forcing distributed heading, if on the right track. This step will lead us to another unorthodox conclusion, namely that language variation is restricted to PF.

1. The locus of structural case in Chomsky 1999

In accord with his views since at least *Lectures on Government and Binding* (1981), Chomsky (1999) assumes that the head hosting tense (T now, Infl in *Lectures*) is the locus of nominative case. As for accusative, he considers two possibilities, v^* and V, assuming the latter without taking a clear stand on the issue, though. I shall here take only the latter into account.

The garden variety transitive construction as in (1) (with subject controlled agreement, as indicated), takes, roughly, the form in (2) in Chomsky's approach:⁴

- | | | | |
|-----|---|--------------------------------------|-------------------------|
| (1) | a | Ég hef lesið þessa bók. | Nom _{Agr} -Acc |
| | | I(N) have(1sg) read this book(A) | |
| | b | Þið hafið lesið þessa bók. | Nom _{Agr} -Acc |
| | | You(Npl) have(2pl) read this book(A) | |

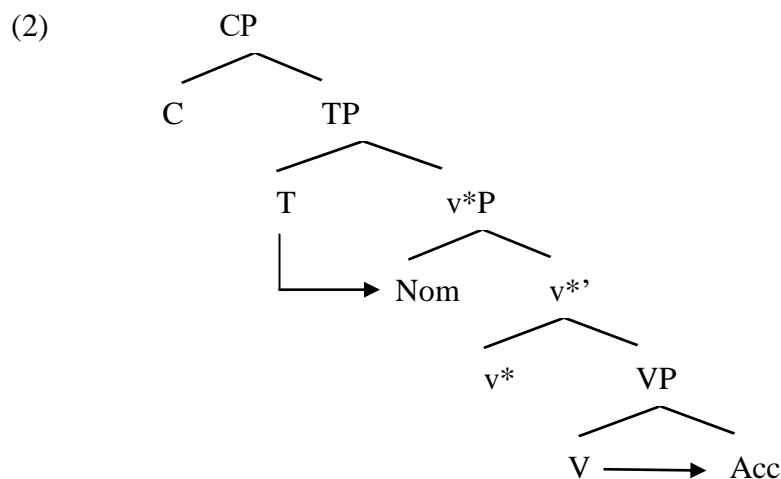

⁴ Unless specifically stated otherwise, all examples in this paper are from either English or Icelandic. For typographical convenience, I use as short grammatical abbreviations as possible in the glosses: N, A, D, G, E for nominative, dative, accusative, genitive and ergative, m, f, n for masculine, feminine and neuter, 1, 2, 3 for first, second and third person, and sg, pl for singular and plural. Thus, for instance, Nm.sg denotes nominative, masculine, singular and 3pl denotes third person plural. Grammatical features that are directly translatable by the English glosses are usually not specifically pointed out (since that would make it harder to process the glosses); thus, the accusative in (1a, b) is singular and the nominative in (1a) is obviously first person singular. Grammatical features that are irrelevant or beside the point are not highlighted either. Thus, the accusative in (1) is feminine, but indicating this would only be confusing as this is totally irrelevant for the point being made by the example. – The purpose of the paper is not to teach out all the wonders of Icelandic morphology.

If the EPP feature of T (optional in UG) is present, T projects a specifier position to which the nominative may move (depending on the availability of alternatives to satisfy EPP, cf. e.g. Holmberg & Nikanne 1999, Holmberg 2000a).

T and V are *probes* and the case-marked arguments are their *goals*. T is selected by C and V is selected by v^* , and both C and v^* are ϕ -complete. Hence, both probes are ϕ -complete as well (T_{comp} , V_{comp}) and enter into an agreement/case-relation with the nominative and the accusative, respectively (probing being conditioned by c-command and Relativized Minimality in the familiar fashion). Case is uninterpretable and so are the ϕ -features of the probes, whereas the ϕ -features of the arguments are interpretable. “Matching of probe-goal induces Agree, eliminating uninterpretable features that activate them” (Chomsky 1999, p. 4). Successful matching (previously called “checking”) of case and concomitant agreement is thus a prerequisite for the convergence of the structure. The extent to which agreement (and case) is actually morphologically visible is dependent on “language-variant PF-manifestation” (Chomsky 1999, p. 3).

In “defective” constructions such as passives and unaccusatives, the light verb is not the strong v^* but a plain v . As the V selected by plain v is not ϕ -complete, it is defective (V_{def}) and does not enter into an agreement relation and is thus incapable of matching accusative. It follows that V is “inactive” and the underlying object is accessible to probing (nominative matching/agreement) by T, as illustrated in (3):

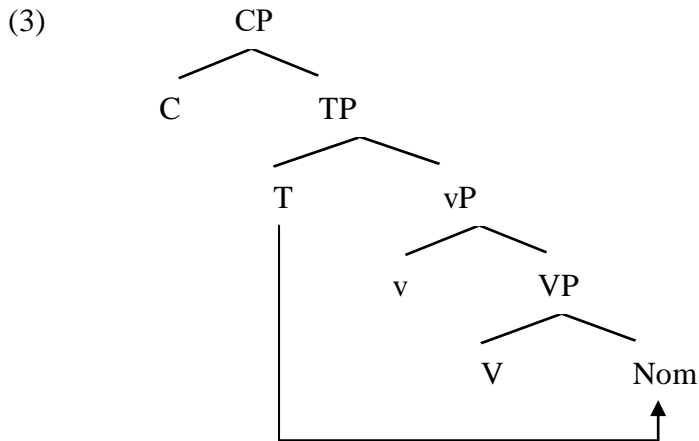

Next, consider the Icelandic Dat-Nom construction:

- (4) Henni **líkuðu** ekki þessar athugasemdir. Dat-Nom_{Aggr}
 her(D) liked(3pl) not these comments(N)
 'She did not like these comments.'

The nominative object normally agrees with the finite verb, as highlighted. A parallel situation arises in ergative case systems, where the ergative is inherent and “absolute” is arguably just another name for nominative (cf. Woolford 1997, 2000 and the references cited there). In Hindi, the relevant case is traditionally called nominative (rather than absolute) and, as in Icelandic, it controls agreement, irrespective of its grammatical function. This is illustrated in (5) and (6) (modelled on Woolford 1997, p. 193, (11) and (13)), where (5) illustrates the nominative-accusative pattern and (6) the coexisting ergative-nominative pattern:⁵

- (5) Raam rotii **khaataa thaa.** Nom_{Aggr}-Acc
 Ram(N.m) bread(A.f) eating(m) was(m)
 'Ram (habitually) ate bread.'
- (6) Ramne rotii **khaayii thii.** Erg-Nom_{Aggr}
 Ram(E) bread(N.f) eaten(f) was(f)
 'Ram had eaten bread.'

⁵ The form *khaataa* is imperfect whereas *khaayii* is perfect. I take the liberty of glossing them with the present versus the past participle.

Chomsky (1999, p. 6) suggests that experiencer verbs are like transitive verbs in being selected by v^* . If so, the (relevant) structure of (4) is as in (7):⁶

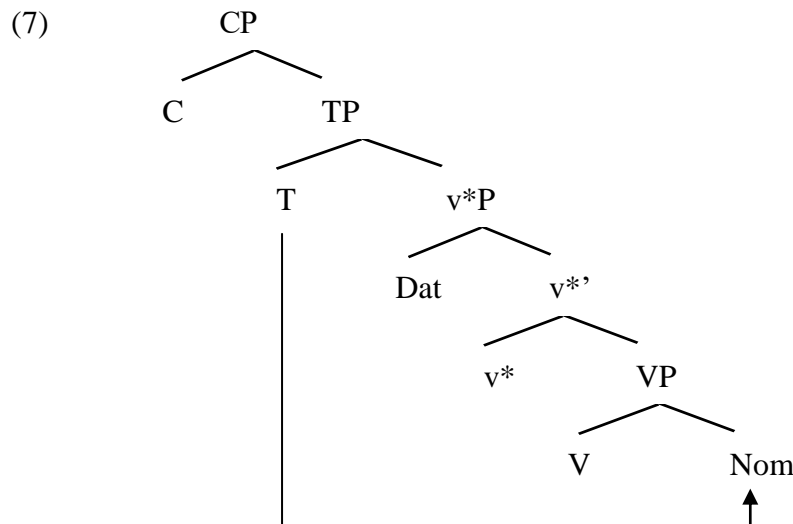

In a structure like this it would thus seem that T probes into the domain of v^* , matching the nominative object and agreeing with it, as indicated, and this is precisely what Chomsky assumes (1999, p. 11). Simultaneously, however, he suggests that the dative has an “additional structural Case feature associated with ϕ -complete v^* ” (1999, fn. 15), thereby adopting the double case approach to quirky subjects (suggested by Belletti 1988 and many others, cf. the discussion in Sigurðsson 1992, 1996).

It is not entirely clear how the double case approach should be implemented, but two possibilities come to mind. First, T might be “responsible” for both an invisible “nominative” case feature of the quirky subject and the nominative of the object, but this raises the immediate question of why the object does not show up in the accusative instead, as in the transitive Nom-Acc construction. Second, the case-matching mechanism of the Dat-Nom construction might be the reverse of that of Nom-Acc constructions, such that v^* matches an invisible “accusative” feature of the

⁶ The dative has to match the theta-selectional feature of V, as will be discussed below.

Dative whereas T matches the nominative of the object. This latter option seems to be what Chomsky has in mind. It is a conceivable analysis, but it is not a particularly elegant one nor does it have any obvious virtues, neither empirically nor conceptually. As we shall see, a simpler and a much less controversial solution is not only available but also both empirically and conceptually preferable.

2. Case is vP-internal

Finite verb agreement in languages like Icelandic (German, Finnish, Russian, etc.) is always nominative controlled. Thus, the optimal assumption in preminimalistic theory was that the nominative object in the Dat-Nom construction is assigned case by its agreeing Infl (as argued by Sigurðsson in a series of works, e.g. 1989, 1991, 1992, 1996). This assumption carries over to the minimalism in Chomsky's work (1998, 1999). In a minimalistic approach, however, the natural assumption is that case is a vP-internal phenomenon, intimately related to thematic roles, whereas agreement is vP-external, related to the situation of utterance or "utterance structure". In other words, nominative case and agreement do not have the same loci even though the agreeing verb receives some of its feature values from a nominative argument. In this section, I develop a vP-internal approach to case, returning to agreement in section 4.

Icelandic is renowned for its quirky case constructions, but our concern here is structural case. Any theory of structural case will have to account for its occurrence in the following constructions, in Icelandic as well as in general:

- (8)
- a The transitive Nom-Acc construction (and Nom-Dat-Acc)
 - b Unaccusative and other "defective" constructions
 - c The Dat-Nom construction

- d ECM constructions
- e Raising constructions

Consider first the v^*P of the transitive construction:

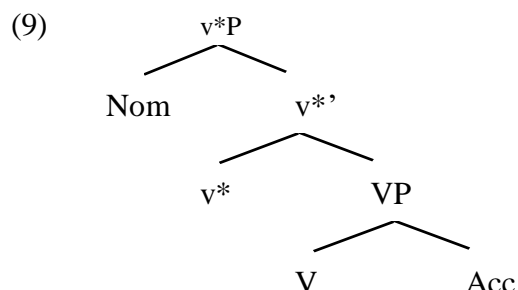

What I now want to propose is that both Nom and Acc are located in v^* ; that is, I want to propose the *vP-case shell hypothesis*:⁷

- (10) vP is a *case shell*, that is, Nom and Acc are different values, value 1 and value 2 (or $\pm Acc$), of one and the same feature located in v

Value 1 (nominative) takes precedence over value 2, i.e. the presence of value 2 is conditioned by value 1 and not vice versa. Figuratively speaking, value 1 is thus “strong”, whereas value 2 is “weak”. The strong value is matched directly by the nominative DP in (9), whereas the weak value is transmitted by a head that is not a case “assigner” in its own right, namely V. More precisely, I assume that the weak value is “handed down” to V or “assigned” to V by v^* and then matched by the accusative DP. This is sketched in (11); the nominative subsequently raises out of v^*P (in expletive constructions as well as in nonexpletive ones):

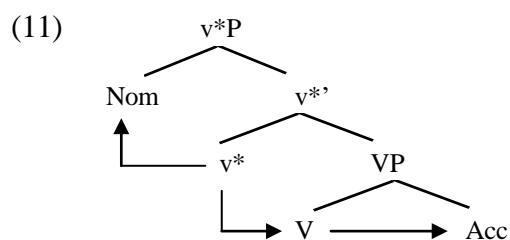

⁷ However, case- v is probably only one of several “little heads” (cf. Arad 1999).

As we shall see in a moment, though, nominative case must sometimes resort to indirect matching through V as well.

This is a “radically minimalistic” approach: V is entirely “innocent” when it merges with its object, having no “knowledge” of the accusative case of the latter. As soon as v^* has been merged, however, both its case feature values must be matched immediately, that is, a nominative has to be merged for the strong value to be matched and the weak case value must be matched transitively through V.⁸ Notice that this is in full accord with the Earliness Principle (cf. Pesetsky 1989, Chomsky 1999), as formulated in (12):

- (12) *Earliness Principle (EP):*
Perform computations as quickly as possible

Ironically, EP replaces Procrastinate: “uninterpretable features must be eliminated at once, as fully as possible” (Chomsky 1999, p. 12).

In passing, notice that this approach enables us to conceive of case in the spirit of Chomsky’s *Visibility Condition* (1986, p. 94 ff.), saying that “an element is *visible* for theta marking only if it is assigned Case”. This particular formulation of the Visibility Condition is admittedly too simplistic, as it does not take case-marking of non-argumental DPs into account. However, it seems to be true in general that case, structural as well as inherent, makes DPs (more) visible to other elements of the clause, above all to its verbal features (cf. e.g. Blake 1994).

Next, consider the vP of defective verbs, such as passives and unaccusatives:

⁸ This induces matching under m-command; this can be avoided if v^* is raised into a position from where it c-commands Nom. I shall not pursue the issue, however. – As for inherent case, I assume that it leads to vacuous matching of structural case, just as in impersonal *pro*-drop constructions (cf. Sigurðsson 1989, 1992).

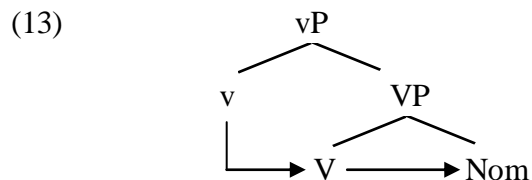

In contrast with v^* , plain v has plausibly only *one* case feature value: As soon as v has been merged, its case feature must be immediately matched. I assume that the sole case feature value of v is strong but nonetheless transmitted via V , in the same way as the weak case feature value of v^* in the transitive construction (alternative strategies being unavailable, as seen). Hence it matches a nominative in the object position. Thus, the vP -internal DPs in (14) and (15) are not mysterious or problematic but precisely what is to be expected:⁹

- (14) a There have been **some people** in the garden.
 b There seem to have been **some people** in the garden.
- (15) a Það hafa sokkið **einhverjir bátar** í höfninni.
 there have(3pl) sunk some boats(N) in harbor-the
 ‘Some boats have sunk in the harbor.’
 b Það virðast hafa sokkið **einhverjir bátar** í höfninni.
 there seem(3pl) have sunk some boats(N) in harbor-the
 ‘Some boats seem to have sunk in the harbor.’

Now, recall that Chomsky assumes that experiencer verbs are like transitive verbs in being selected by v^* rather than v , cf. (7) above. For reasons to be discussed directly, I shall instead assume that experiencer verbs are like unaccusatives in being selected by the plain v . If so, the relevant substructure of the Dat-Nom construction is not as in (7) but the as in (16):

⁹ As argued by Sigurðsson (in e.g. 1989, 1992:22-23), contra Belletti (1988) and Lasnik (1992).

(16)

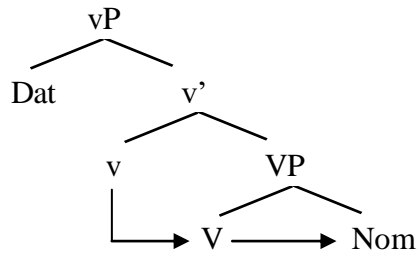

Just as in (13), *v* has only one (strong) case value, matched via *V*. Accordingly, the nominative of the object is simply the “normal” and expected form. A particularly welcome result of this simple view is that case matching is both local and immediate, and no look-ahead is needed.

The reason to assume *v** in the Dat-Nom construction is not trivial, though. The structure in (16) raises the question of how the dative is structurally licensed if not by entering into an (invisible) agreement-case relation with either *T* or *v/v**. However, the answer to this question is not to be found within structural case theory. Thus, the double object construction allows a dative argument in addition to its nominative subject and its accusative direct object, as in (17a) from Icelandic, (17b) from German, and (17c) from Turkish (modelled on Blake 1994, p.1, (1)):

- (17) a Við höfum ekki gefið **henni** pennana.
 we(N) have not given her(D) pens-the(A)
 ‘We haven’t given her the pens.’
- b Wir haben **ihm** das Buch nicht gegeben.
 we(N) have him(D) the book(A) not given
 ‘We didn’t give him the book.’
- c Mehmet **adma** elmarlı verdi.
 Mehmet(N) man(D) apples(A) gave
 ‘Mehmet gave the apples to the man.’

Much as in English and other related languages, indirect objects have to meet rather strict structural conditions in Icelandic, that is, they have to be structurally licensed. Whatever the mechanism involved may be, however, it

is clearly not the nominative-accusative mechanism of the language. The same is obviously true of for instance free benefactives, as in (18) and (19):¹⁰

(18) He made **me** some soup.

(19) Ég lagaði **mér** súpu.
I(N) made me(D) soup(A)

It is noteworthy in this connection that Icelandic allows six combinations of structural and inherent case-marking in the double object construction (cf. Yip, Maling & Jackendoff 1987, p. 226), but none of them involves a double structural accusative (on both objects) or a double nominative (on the subject and one of the objects).¹¹

Dat-Nom passives provide yet another reason to believe that Dat-Nom constructions in general involve plain *v* rather than *v**. Compare the passive in (20) with its active counterpart in (17a) above:

(20) **Henni** hafa ekki verið gefnir **pennarnir**.
her(D) have(3pl) not been given pens-the(N)
'She has not been given the pens.'

Precisely as in the garden variety of passives of monotransitive verbs, the weak (accusative) case value, inherently correlated to *v**, is lacking here. It would thus seem natural to assume that it is absent in Dat-Nom constructions in general.

Dative arguments tend to have quite regular role-semantics, as experiencers or benefactives (cf. e.g. Jónsson 2000 and references cited there), and it seems clear that they have to match a theta-selectional feature of their V. Reconsider the structure in (16) = (21):

¹⁰ Interestingly, free benefactives are more heavily constrained in Icelandic than in e.g. English and the Mainland Scandinavian languages, as discussed by Holmberg & Platzack (1995, p. 201 ff.).

¹¹ One verb, *kosta* 'cost', allows two accusative objects, but the second object is arguably inherently and not structurally case-marked. – Predicative constructions

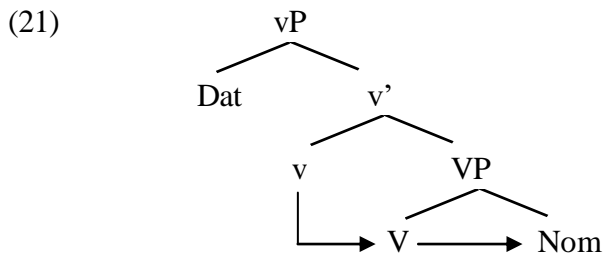

While *v* activates *V* as a case matcher, *V*, in turn, matches its external theta-feature against the dative via *v*. Apparently, this feature matching at least partly licenses the dative.¹² Notice that this *vP*-internal licensing is distinct from the EPP feature that applies at the *vP*-external functional level of the clause (briefly discussed in sections 4 and 6).

Nominative and accusative objects show exactly the same word order properties, as illustrated below:

- (22) a Henni hafa því sennilega ekki leiðst **þeir** um kvöldið
 her(D) have thus probably not bored they(N) in evening-the
 ‘She has thus probably not been bored by them in the evening.’
 b Henni leiddust **þeir** því sennilega ekki um kvöldið.
 her(D) bored they(N) thus probably not in evening-the
- (23) a Hún hefur því sennilega ekki hitt **þá** um kvöldið.
 she(N) has thus probably not met them(A) in evening-the
 b Hún hitti **þá** því sennilega ekki um kvöldið.
 she(N) met them(A) thus probably not in evening-the

In the *b*-examples, the objects have been Object Shifted, but in the *a*-examples, they both show up in a deep post-*V* position. Although data of this sort do not have direct bearing on the locus of case, it is at least clear that they are precisely as expected under the assumption that nominative and accusative objects are case-matched in a parallel fashion.

involve double nominatives, of the subject and the predicate, whether it is an AP or an NP (cf. Maling & Sprouse 1995), but these fall outside the scope of the present study.

¹² The “true” explanation may well be that there is some kind of a lexical redundancy rule (or tendency) that relates dative case and certain theta-roles, but this is immaterial for our purposes.

In sum, we have seen here that the vP case shell approach is at least a plausible alternative to the standard “nominative in T” approach. Moreover, the vP case shell hypothesis derives (the case aspect of) Burzio’s generalization in a trivially simple manner and enables us to formalize the intuition that the structural cases are different values of one and the same feature, as opposed to inherent cases (much as e.g. “number” is a complex feature, having different values like [+sg] and [-sg]). In the next three sections, we shall see that the vP case shell approach is in fact superior to “nominative in T”, both empirically and conceptually.

3. DP-displacement is (largely) “semantically” driven

If case is vP-internal, it follows that DP-displacement (NP-movement) cannot possibly relate to case-matching, and, second, that the locus of agreement is not the same as that of case. I shall discuss (certain aspects of) displacement in this section, returning to agreement in section 4.

As is well known (since Platzack & Holmberg 1989), logical subjects are licensed in the “middle field” in the expletive-associate construction in Icelandic, as opposed to the mainland Scandinavian languages. Hence the difference between (24) and its Swedish counterpart in (25):

- (24) Það mundu **einhverjir bátar** hafa verið seldir á uppboðinu.
 there would some boats(N) have been sold at auction-the
 ‘Some boats would have been sold at the auction.’
- (25) *Det skulle **några båtar** ha sålts på auktionen.
 there would some boats have been-sold at auction-the

Following common practise, I shall refer to this construction as *TEC* (the Transitive-Expletive Construction), even when the main verb is not transitive.

Bobaljik & Jonas (1996; see also e.g. Bobaljik & Thráinsson 1998) relate this difference to another difference between the languages in question, namely that Icelandic has verb raising (“V-to-I”) whereas Mainland Scandinavian has not, as illustrated in (26) and (27):

(26) ... að hann **hefur** *ekki* selt bátana.
that he has not sold boats-the
'... that he hasn't sold the boats.'

(27) ...att han *inte* **har** sált bátarna.
that he not has sold the boats

In Bobaljik and Jonas's approach, nominative case in Icelandic is checked in Spec,TP as a result of V-raising to T. As there is no such raising in the mainland Scandinavian languages, they cannot check nominative case in Spec,TP, hence the contrast in (24)-(25).

However, nominative subjects of unaccusatives and passives are quite “happy” in the object position in Icelandic (and so are indefinite subjects in many other languages):¹³

(28) Það mundu þá sennilega ekki verða seldir **bátar** á uppboðinu.
there would then probably not be sold boats(N) at auction-the
'Boats would then probably not be sold at the auction.'

In Icelandic and the other Scandinavian languages, vP-internal subjects must normally be indefinite, but we don't have to look far for a different type of language: Finnish is a language that allows definite nominative subjects vP-internally rather freely, as discussed by Holmberg & Nikanne (1999).¹⁴ This is seen in the examples below, taken from Holmberg and Nikanne's paper (-*ko* in *onko* is a question marker, as indicated):¹⁵

¹³ As pointed out in Sigurðsson 1989, 1992, 1996 (cf. also the analysis in Chomsky 1998, 1999).

¹⁴ Finnish does not allow weak nominative pronouns VP-internally, though (Anders Holmberg, p.c.).

¹⁵ Even Icelandic allows definite VP-internal nominatives, albeit under much more constraining pragmatic conditions (cf. Sigurðsson 1989, pp. 294-295).

- (29) a Tämän kirjan on kirjoittanut **Graham Greene**.
this book has written Graham Greene
b Onko tämän kirjan tosiaan kirjoittanut **Graham Greene**?
has-Q this book really written Gramhan Greene

Even more tellingly, Icelandic logical subjects are well-formed in not only one but in many vP-external positions, as (modestly) illustrated below:

- (30) a Það mundu **einhverjir bátar** þá sennilega ekki verða seldir á uppboðinu.
there would some boats(N) then probably not be sold at auction-the
'Some boats would then probably not be sold at the auction.'
b Það mundu þá **einhverjir bátar** sennilega ekki verða seldir á uppboðinu.
c Það mundu þá sennilega **einhverjir bátar** ekki verða seldir á uppboðinu.
d Það mundu þá sennilega ekki **margin bátar** verða seldir á uppboðinu.
there would then probably not many boats(N) be sold at auction-the

Obviously, an explanation of displacement in terms of nominative case could at most account for one of the available subject positions. Moreover, the “middle field” is actually accessible to subjects in both Norwegian and Swedish, albeit not in expletive constructions (cf. Holmberg 1993, Nielsen 1997, Cinque 1999, Svenonius 2000). This is illustrated for Swedish in (31):¹⁶

- (31) a Därför hade **pojkar** förmodligen faktiskt inte heller läst böckerna.
therefore had boys-the presumably actually not either read the books
'Therefore, the boys had presumably actually not read the books either.'
b Därför hade förmodligen **pojkar** faktiskt inte heller läst böckerna.
c Därför hade förmodligen faktiskt **pojkar** inte heller läst böckerna.
d Därför hade förmodligen faktiskt inte heller **pojkar** läst böckerna.

Let us refer to this as the *Late Subject Construction* (LSC), thereby contrasting it with the Icelandic TEC. Both constructions involve *Subject Float*.

The reason why Icelandic as opposed to Mainland Scandinavian allows TEC is presumably related to the fact that the Icelandic expletive is only grammatical preverbally, whereas there is no such restriction on

¹⁶ These examples are modelled on examples from Christer Platzack's spring lectures at the University of Lund, 2000.

Mainland Scandinavian expletives (cf. e.g. Falk 1993, Holmberg and Platzack 1995, Vikner 1995) – although the exact nature of the relation in question is by no means obvious (cf. Vangsnes 1999, p. 188 ff.). On the other hand, it is unclear why LSC is much more heavily constrained in both Danish and Icelandic than in Norwegian and Swedish – and I shall not pursue the matter.

In the approach of Rizzi (1997), the complementizer system or the C-domain involves not only the highest Force Phrase (CP) but also iterated Topic Phrases (TopP*) with an intervening Focus Phrase, above both the Fin(iteness) Phrase and IP (for related ideas, see Platzack 1998). Thus, the relevant functional heads come in the following order (where Force normally hosts either a complementizer or the finite verb):

(32) Force – Top* – Foc – Top* – Fin – Infl

The Scandinavian languages as well as e.g. Finnish (cf. Holmberg & Nikanne 1999) and Malayalam (Jayaseelan 2000) lend support to only a single Topic Domain below Force plus a lower Focus Domain. Thus, instead of (32), I assume (33):

(33) Force – Top* – Foc* – Fin ...

In addition, it seems that sentence adverbials can freely show up in either the Topic Domain or the Focus Domain.¹⁷ In case they are placed in the Topic Domain they are normally not repeated in the Focus Domain, but, notably, (some of) their being repeated there does not lead to

¹⁷ Thanks to Christer Platzack for suggesting this idea to me. – Notice, however, that this indicates a much higher positioning of sentence adverbs than assumed by Cinque (1999).

ungrammaticality, as seen from examples like the following (where the finite verb presumably stays put in Top):¹⁸

- (34) Hann **sennilega** bara hefur þá **sennilega** ekki lesið þessa bók.
 he probably just has then probably not read this book
 ‘He then probably just hasn’t read this book.’

Similar facts are found also in e.g. Swedish.¹⁹

Given the approach in (33), we can conceive of floating (topical or [+Top]) subjects in the Norwegian/Swedish LSC as being situated in the Topic Domain, whereas floating (focal or [+Foc]) subjects in the Icelandic TEC are situated in the lower Focus Domain.

Object Shift offers some support to this approach. Consider the following examples from Icelandic:

- (35) a Það lásu **hana** þá sennilega ekki **margir stúdentar** fyrir prófið.
 there read it(A) then probably not many students(N) before exam-the
 b *Það lásu þá **hana** sennilega ekki **margir stúdentar** fyrir prófið.
 c *Það lásu þá sennilega **hana** ekki **margir stúdentar** fyrir prófið.
 d *Það lásu þá sennilega ekki **hana** **margir stúdentar** fyrir prófið.
 e ?Það lásu þá sennilega ekki **margir stúdentar** **hana** fyrir prófið.

Being a weak pronoun, the object is [+Top] and hence it cannot shift into the Focus Domain, whereas it may and preferably does shift across the Focus Domain into the higher Topic Domain. This is sketched below:

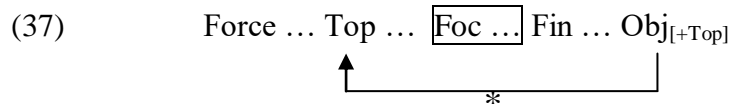
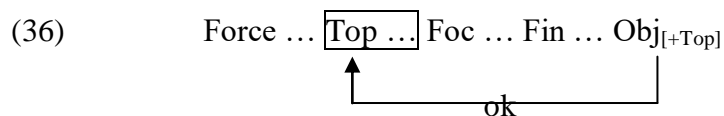

English allows Subject Float to only a limited extent, as in (38):

¹⁸ While facts of this sort indicate grammaticalization (cf. Roberts & Roussou 1999), they cast doubts on the validity of Cinques approach (1999) to adverb placement (and so do many of the facts discussed in Jónsson 1999, Haider 2000 and Svenonius 2000).

¹⁹ Lars-Olof Delsing, Gunlög Josefsson, Christer Platzack (p.c.).

- (38) There were **several packages** placed ___ on the table

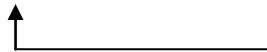

Chomsky's (1999) refers to this (well-known) type of displacement as "Thematization/Extraction", *TH/EX*, and suggests that it is an "operation of the phonological component" (p. 16), because it does not seem to have semantic effects, "surface semantic effects [being] restricted to narrow syntax" (p. 11).

It seems however that Subject Float is sensitive to semantic factors. Consider the Icelandic facts in (39)-(43), summarized in a schematized manner in (44):

- (39) a *Það mundu **kommar** þá sennilega ekki hafa verið kosnir í stjórnina.
there would commies then probably not have been elected to board-the
b *Það mundu þá **kommar** sennilega ekki hafa verið kosnir í stjórnina.
c *Það mundu þá sennilega **kommar** ekki hafa verið kosnir í stjórnina.
d *Það mundu þá sennilega ekki **kommar** hafa verið kosnir í stjórnina.
e Það mundu þá sennilega ekki hafa verið kosnir **kommar** í stjórnina.
- (40) a Það mundu **einhverjir** þá sennilega ekki hafa verið kosnir í stjórnina.
... some (people) ...
'Some (people) would then probably not have been elected to the board.'
b ?Það mundu þá **einhverjir** sennilega ekki hafa verið kosnir í stjórnina.
c ?Það mundu þá sennilega **einhverjir** ekki hafa verið kosnir í stjórnina.
d *Það mundu þá sennilega ekki **einhverjir** hafa verið kosnir í stjórnina.
e *Það mundu þá sennilega ekki hafa verið kosnir **einhverjir** í stjórnina.
- (41) a Það mundu **einhverjir kommar** þá sennilega ekki hafa verið kosnir ...
... some commies ...
b Það mundu þá **einhverjir kommar** sennilega ekki hafa verið kosnir ...
c Það mundu þá sennilega **einhverjir kommar** ekki hafa verið kosnir ...
d ?Það mundu þá sennilega ekki **einhverjir kommar** hafa verið kosnir ...
e ?Það mundu þá sennilega ekki hafa verið kosnir **einhverjir kommar** ...
- (42) a Það mundu **margir** þá sennilega ekki hafa verið kosnir í stjórnina.
... many (people) ...
b ?Það mundu þá **margir** sennilega ekki hafa verið kosnir í stjórnina.
c *Það mundu þá sennilega **margir** ekki hafa verið kosnir í stjórnina.
d Það mundu þá sennilega ekki **margir** hafa verið kosnir í stjórnina.
e Það mundu þá sennilega ekki hafa verið kosnir **margir** í stjórnina.

- (43) a Pað mundu **margir kommar** þá sennilega ekki hafa verið kosnir ...
 ... many commies ...
 b ?Pað mundu þá **margir kommar** sennilega ekki hafa verið kosnir ...
 c ?Pað mundu þá sennilega **margir kommar** ekki hafa verið kosnir ...
 d Pað mundu þá sennilega ekki **margir kommar** hafa verið kosnir ...
 e Pað mundu þá sennilega ekki hafa verið kosnir **margir kommar** ...
- (44)
- | | | 1 | 2 | 3 | 4 | 5 |
|---|-----------------------|----|----|----|----|----|
| a | Bare indefinites (f): | * | * | * | * | ok |
| b | “Some”: | ok | ? | ? | * | * |
| c | Some f: | ok | ok | ok | ? | ? |
| d | “Many”: | ok | ? | * | ok | ok |
| e | Many f: | ok | ? | ? | ok | ok |

These facts illustrate only a fraction of the factors involved in Subject Float (for a discussion of some such factors, see Vangsnes 1999, p. 184 ff.), but they show quite clearly that it is sensitive to the information structure of the subject DP. However, this does not undermine Chomsky’s (1999) suggestion that TH/EX or Subject Float is an “operation of the phonological component”.²⁰ The positioning of phrases is in general highly sensitive to phonological strategies such as stress and intonation and such strategies obviously reflect or interact with information structure.²¹

As argued by Vangsnes (1999), the immediate post-Force position (position “1” in (44)) is largely reserved for specific and other “strong” readings (of indefinite and in fact some definite DPs) in the Milsarkian sense, i.e. one could perhaps argue that raising to this position *has* semantic effects. I believe, however, that it has semantic or informational correlates rather than effects. At any rate, it is clear that PF “sees” certain semantic or informational features, and hence a PF-movement approach to the displacement facts illustrated above does not obviously exclude the

²⁰ But for a different view, see e.g. Nielsen 1997, Cinque 1999, Holmberg 2000b.

²¹ The important role of phonological strategies in “syntax” in the traditional sense is largely neglected in the generative literature, presumably for the trivial reason that syntacticians (like myself) do not in general master the appropriate tools to analyze such strategies.

possibility that distinct functional heads and specifier positions are involved.

I conclude that DP-displacement is largely “semantically” or informationally driven - at PF. Whatever the exact nature of the features involved may be, it seems quite clear that case is not one of these features. This is precisely what we expect if case is vP-internal.

4. Agreement

Icelandic finite verb agreement is always nominative-controlled (cf. Sigurðsson 1996 and the references cited there). If the clause does not contain a nominative, the finite verb shows up in an invariable default form, homophonous with the agreeing third person singular form. This is illustrated in (45) for main verbs and in (46) for an auxiliary:

- (45) a Stundum **rignir** mikið hérna.
sometimes rains(3sg) much here
‘It sometimes rains much here.’
b Okkur **var**/*vorum kalt.
us(D) was(3sg)/*were(1pl) cold
‘We were cold.’
c Ykkur **vantar**/*vantið bókina.
you(Apl) lack(3sg)/*2pl book-the(A)
‘You lack the book.’
- (46) a Stundum **hefur** rignt mikið hérna.
sometimes has(3sg) rained much here
‘It has sometimes rained much here.’
b Okkur **hefur**/*höfum verið kalt.
us(D) has(3sg)/*have(1pl) been cold
‘We have been cold.’
c Ykkur **hefur**/*hafið vantað bókina.
you(Apl) has(3sg)/*have(2pl) lacked book-the(A)
‘You have lacked the book.’

Thus, even though the clause-initial DPs in the *b*- and *c*-examples are (non-nominative, quirky) subjects, they are blocked from controlling agreement. In

contrast, nominative subjects trigger obligatory agreement, as in the transitive Nom-Acc examples below:

- | | | | | | |
|------|---|------------------------------------------------------------------|------|---|-------------------------------------------------------|
| (47) | a | Ég hef lesið þessa bók.
I have read this book | (48) | a | Ég las þessa bók.
I read this book |
| | b | Þú hefur lesið þessa bók.
you(sg) have read this book | | b | Þú last þessa bók.
you(sg) read this book |
| | c | Hún hefur lesið þessa bók.
she has read this book | | c | Hann las þessa bók.
he read this book |
| | d | Við höfum lesið þessa bók.
we have read this book | | d | Við lásu þessa bók.
we read this book |
| | e | Þið hafið lesið þessa bók.
you(pl) have read this book | | e | Þið lásuð þessa bók.
you(pl) read this book |
| | f | Þær hafa lesið þessa bók.
they(f) have read this book | | f | Þeir lásu þessa bók.
they(m) read this book |

There is thus a close correlation between nominative case and agreement. The simplest account for this correlation would seem to be the traditional one, namely that nominative and agreement have one and the same locus, the agreeing clausal head (cf. e.g. Sigurðsson 1989, 1996; Chomsky 1999). However, if case is vP-internal it cannot have the same locus as agreement, the latter being vP-external. Second, there are reasons to believe that agreement has not only one but two vP-external loci, a number head and a person head, and nominative case could of course at most have the same locus as one of them. Third, and most tellingly, there is by no means a one-to-one mapping between nominative case and agreement. The general picture can be sketched (in a somewhat gross manner) as follows:²²

- | | | | | |
|------|---|------------------------|---|---------------------------|
| (49) | a | No nominative | → | – agreement (3sg) |
| | b | Nominative subject | → | + agreement |
| | c | Nominative nonsubjects | → | ± agreement or *agreement |

The interesting issues arise in connection with mismatches of type (49c). We will primarily be concerned with two subtypes:

- | | | |
|------|---|------------------------------------------------------------------------|
| (50) | a | Nominative objects, blocked from controlling person agreement |
| | b | Other “deep” nominatives, primarily in infinitival constructions, that |

²² The relevant facts are illustrated in some detail in Sigurðsson 1996.

either induce only optional number agreement or do not relate to finite verb agreement at all

We will discuss nominative objects in this section, returning to some other “deep” nominatives in section 5.

As mentioned in section 1, the verb normally agrees with its nominative *object* in the Dat-Nom construction, as in (51):

- (51) a Henni leidd**ust** þessar athugasemdir.
her(D) bored(3pl) these comments(N)
‘She was annoyed by these comments.’
b Henni líkuð**u** ekki þessar athugasemdir. = (4)
her(D) liked(3pl) not these comments(N)
‘She didn’t like these comments.’

Crucially, however, object controlled agreement is confined to third person, that is to say, first and second person objects are blocked from controlling agreement. Given that third person is actually [-1p, -2p] or “no person” (as has been argued by many, e.g. Anderson 1982. p. 576), the relevant generalization can be phrased as follows (cf. Sigurðsson 1996, p. 34):

- (52) Objects are blocked from controlling [+Person] agreement

Hence, the following judgements:

- (53) a *Henni líkuð**um** við.
her(D) liked(1pl) we(N)
b *Henni líkuð**uð** þið.
her(D) liked(2pl) you(Npl)
c Henni líkuð**u** þeir.
her(D) liked(3pl) they(N)
‘She liked them.’
- (54) a *Henni höfð**um** leiðst við.
her(D) had(1pl) bored we(N)
b *Henni höfð**uð** leiðst þið.
her(D) had(2pl) bored you
c Henni höfð**u** leiðst þeir.
her(D) had(3pl) bored they
‘She had found them boring.’

- (55) a *Henni vor**um** sýndir við.²³
 her(D) were(1pl) shown we(N)
 b *Henni vor**uð** sýndir þið.
 her(D) were(2pl) shown you(Npl)
 c Henni vor**u** sýndir þeir.
 her(D) were(3pl) shown they(N)
 ‘They were shown to her.’
- (56) a Við vor**um** sýndir henni.
 ‘We were shown to her.’
 b Þið vor**uð** sýndir henni.
 ‘You were shown to her.’
 c Þeir vor**u** sýndir henni.
 ‘They were shown to her.’

Interestingly, there is an inverse correlation between visibility of agreement and acceptability of first and second person nominative objects: Such objects regularly gain in acceptability the less visible agreement they trigger, becoming even quite acceptable for many speakers if the relevant agreeing form happens to be identical with the default third person singular form. Thus, many speakers get the following judgements (or a similar judgement pattern):²⁴

- (57) a Henni leiddist ég. *leiddist* = 1sg, 2sg, 3sg
 her(D) bored I(N)
 ‘She found me boring.’
 b Henni líkaði ég. *líkaði* = 1sg, 3sg
 her(D) liked I(N)
- (58) a *Henni leiddumst við. *leiddumst* = 1pl
 her(D) bored we(N)
 b ?Henni leiddust við. *leiddust* = 2pl, 3pl
 c Henni leiddist við. *leiddist* = 1sg, 2sg, 3sg
 ‘She found us boring.’

The fact that nominative objects may control number agreement as opposed to (true) person agreement obviously suggests that number and

²³ Icelandic ditransitive Nom-Acc-Dat verbs allow both Dat-Nom and Nom-Dat passives (normally with a slight preference for the Dat-Nom pattern); certain active predicates (mainly psych-verbs) also have the option of showing up as either Dat-Nom or Nom-Dat, see section 5.

²⁴ For a more detailed discussion of facts of this sort, see Sigurðsson 1996, p. 33 ff.

person are matched by distinct heads, and that is precisely the line of reasoning I shall take. Taraldsen (1994, 1995) and Sigurðsson (1996) assume that the heads in question are AgrS and AgrO, but I suggest instead that they are simply Num(ber) and Pers(on). – The conceptual issues at stake here are by no means trivial, but I shall postpone discussing them until in the concluding section.

I assume that the full finite clause structure minimally involves the following functional heads below the CP-domain:

(59) Num – Pers – Mood – T – Asp – Voice – v

It is (at least partly) an empirical question whether functional heads come in a universally fixed order (cf. Cinque 1999, Julien 2000 and many others). I tentatively assume that they do and that the order in (59) is universal (but for further discussion, see section 6). Abstracting away from M, Asp, and Voice, the relevant structure of the Nom-Acc construction is the following:

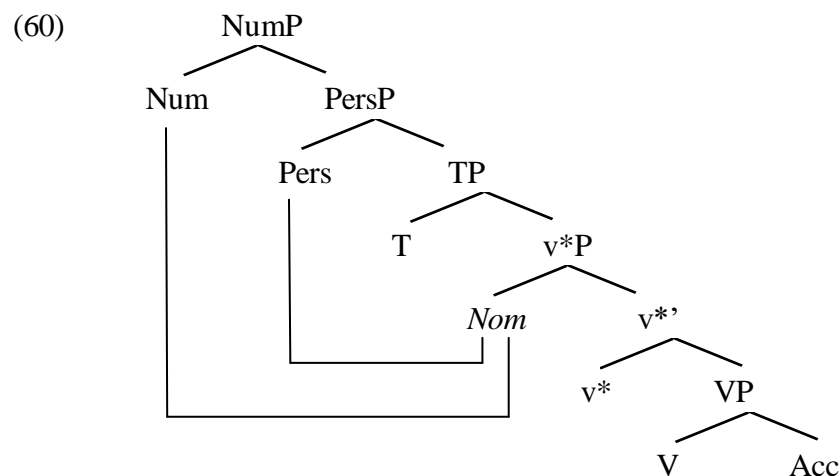

Both Num and Pers are probes in the sense of Chomsky 1999, matching the closest possible goal, thereby inducing Agree (matching or Agree being conditioned by command and Relativized Minimality, in the familiar manner). Subsequent merger or raising of the subject or some other lexical

category matches the EPP feature of the clause, giving the surface order SV_{Agr} or XV_{Agr} (cf. Holmberg 2000a).

In (60), the closest possible goal for both Num and Pers is the nominative subject in $Spec,v^*P$, as indicated (hence the full person and number agreement in e.g. (47)-(48) above). The same scenario is found in “defective” constructions, for instance unaccusative constructions (apart from the position of the nominative, irrelevant in this connection), cf. (61):

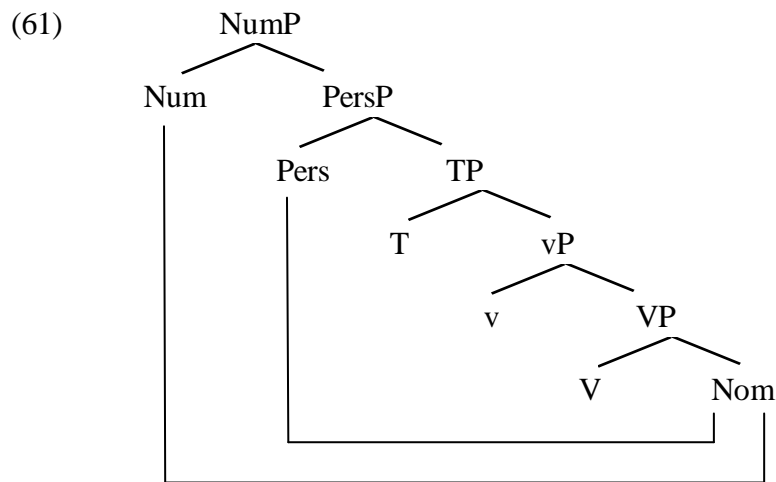

It follows that both number and (true) person reach the VP-internal nominative, hence the full agreement in (62) (where the subject has been raised for the purposes of EPP):

- (62) Við **höfum** því aldrei horfið.
we(N) have(1pl) thus never disappeared

Chomsky (1999) tentatively suggests that EPP reduces to (true) Person matching. This would account for the contrast between (63a), with a third person or a “no person” subject, and (63b), with a second (true) person subject, which accordingly would have to raise to the EPP position in order to match the person/EPP feature:

- (63) a **Þá mundu hafa horfið peningar.**
 then would(3pl) have disappeared money(Npl)
 ‘Then, money would have disappeared.’
 b ***Þá munduð hafa horfið þið.**
 then would(2pl) have disappeared you(Npl)

Moreover, this would seem to account for the exclusion of first and second person nominative objects, as in (64) = (53); the nominatives in (64a, b) should raise in order for the true person/EPP feature to be matched, but, as they don’t raise, the derivation crashes:

- (64) a ***Henni líkuðum við.**
 her(D) liked(1pl) we(N)
 b ***Henni líkuðu þið.**
 her(D) liked(2pl) you(Npl)
 c **Henni líkuðu þeir.**
 her(D) liked(3pl) they(N)

However, elegant as it may seem, this approach breaks down immediately. First, obligatory subject raising or EPP does clearly not reduce to (true) person matching, as seen by the fact that nonraised pronominal subjects are categorically ungrammatical, irrespective of person. Thus, (65a) is just as ungrammatical as (65b):

- (65) a ***Þá mundu hafa horfið þeir.**
 then would(3pl) have disappeared they(Npl)
 b ***Þá munduð hafa horfið þið.** = (63b)
 then would(2pl) have disappeared you(Npl)

Whatever the right formulation of EPP and/or the Definiteness Effect may be, it cannot be stated in terms of person.

Second, and more compellingly, Pers *can* (and must) access vP, in examples like the following:²⁵

²⁵ *Það* ‘it’ is the syntactic subject in these examples, whereas the vP-internal nominatives are predicate NPs. The reason why *það* cannot control finite verb agreement is plausibly that it lacks case and ϕ -features, like expletive *það* (cf. Sigurðsson 1996). Alternatively, *það* might be merged so late or high that it never enters the domains of Num and Pers. – This construction is also found in German (Josef

- (66) Það **erum** bara **við**.
it are(1pl) only we(N)
'It's only us.'
- (67) Það **hafið** þá sennilega verið **þið** (sem unnuð keppnina).
it have(2pl) then probably been you(Npl) (who won(2pl) competition-the)
'It's then probably been you (who won the competition).'

On the assumption that *það* is not a potential goal for Num and Pers, it follows that, with respect to the mechanism of agreement, these examples are no different from full subject agreement examples like (62) above (with the structure in (61)): Both Num and Pers agree with their closest possible goal.

Plausibly, then, the reason why Pers cannot reach the VP-internal nominative in the Dat-Nom construction, as in e.g. (64a, b), has nothing to do with the location of the nominative per se; rather, the reason is that the dative somehow “intervenes” between Pers and the nominative, i.e. we are presumably dealing with a somewhat particular case of Relativized Minimality.

Capitalizing on suggestions and observations made in Jónsson (1996), Schütze (1997) and in particular Boeckx (1998, p. 11-12), I propose the following understanding of this *Dative-Intervention*:²⁶

- (68) In the Dat-Nom construction, the dative satisfies the matching requirements of Pers (inducing “null-agreement”), thereby intervening between Pers and the nominative (by Relativized Minimality)

In contrast, Num skips the dative and goes for the nominative instead. This is illustrated in (69):

Bayer, Ute Bohnacker, p.c.), although its “reverse” is more common (i.e. *Wir sind es nur* = we are it only).

²⁶ It is not clear that this intervention effect extends to inherent cases in general, and I shall not pursue the matter.

(69)

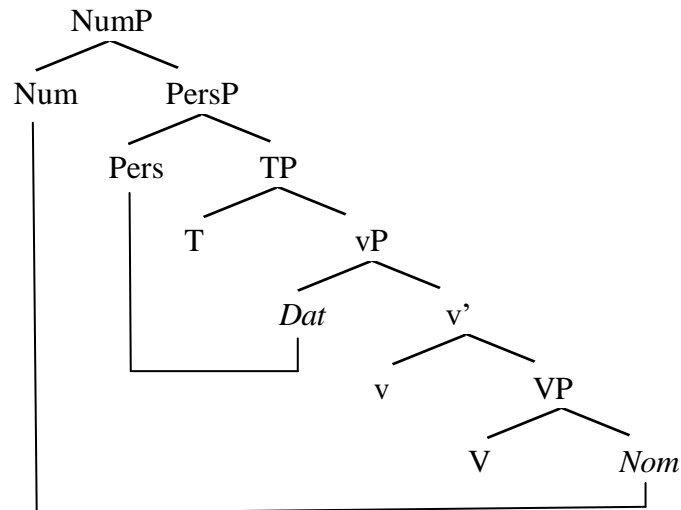

Notice that the agreement paths are nested, the structure thus obeying the Principle of Minimal Compliance (cf. Richards 1998, p. 601).²⁷ In the absence of any evidence to the contrary, I thus take it that analyzing Num as asymmetrically c-commanding Pers is substantiated.²⁸

Alternatively, the dative raises out of both PersP and NumP after Person matching has taken place but prior to Number matching. If so, it does not intervene (phonologically) between Num and the nominative object (which might explain why it does not induce a Relativized Minimality violation with respect to number agreement).

The present approach assumes distributed heading (DH) in the sense that each functional head comprises only a single formal feature (see further section 6). It is not impossible, however, to subsume Dative-Intervention under compact heading, for instance such that both Num and Pers are adjoined to T or Fin (cf. Julien 2000, chapter 7; Chomsky 1999). However, this would force us to assume that features hosted by one and the same functional head have different probing ranges. As I can see no principled

²⁷ As predicted by the Principle of Minimal Compliance, the dative must raise out of vP (even when indefinite), presumably to Spec,Pers at least, but illustrating and discussing this would take us too far astray.

²⁸ Bejar (2000) reaches the same conclusion for Georgian, on rather different premises, though.

reason for making this rather peculiar assumption, I take it that it should be rejected in favor of the simpler and more natural DH approach.²⁹

We are now in a position to state the following generalizations for Icelandic finite verb agreement:

- (70) a Pers matches the closest possible goal
 b Num matches the closest possible nominative

For some speakers, however, number agreement is only optional in the Dat-Nom construction (cf. Sigurðsson 1996, p. 24-25), and for yet other (younger?) speakers, agreement is even out. For this third group of speakers, then, the judgements are as in (71):³⁰

- (71) a Þeim leiddist/*leiddust strákar.
 them(D) bored(3sg/*3pl) the boys(N)
 ‘They were bored by the boys.’
 b Þeim líkaði/*líkuðu ekki þessar hugmyndir.
 them(D) liked(3sg/*3pl) not these ideas(N)

For these speakers, thus, agreement observes the generalization in (72):

- (72) A probe matches the closest possible goal

Interestingly, this development, if true and general, entails that the language is getting even more quirky (in the sense that Num and Pers matching makes no syntactic distinction between nominative and non-nominative matching goals).

It has long been a puzzle that German differs from Icelandic in not having quirky subjects in spite of having many case patterns that are both semantically and morphologically similar to Icelandic quirky case patterns (cf. e.g. Zaenen et al. 1985, Sigurðsson 1989, 1992). The present analysis,

²⁹ The distinction between Num and Pers is also supported by both cross-linguistical and historical facts (cf. e.g. the historical facts discussed in Falk 1993, p. 154 ff.).

³⁰ Jóhannes Gísli Jónsson informs me that many of his syntax class students, aged 20-25, “dislike” object controlled number agreement (as opposed to the middle aged informants reported on in Sigurðsson 1996).

however, enables us to state this difference between the two languages in terms of the following, quite simple *Matching Parameter*:

- (73) Pers matches the closest possible:
 a Goal: Icelandic
 b Nominative: German

Thus, “subjectization” is largely contingent on Person matching, even though EPP, being a more diversified phenomenon, is not.

5. “Deep” nominatives: further evidence for the vP case shell

It is not entirely obvious why only nominatives may control morphologically visible finite verb agreement in a quirky case language like Icelandic, nor is it obvious why Icelandic behaves more or less the same in this respect as many “non-quirky” or at least “less quirky” languages, such as German, Latin, Russian and Finnish. There is a strong tendency in the languages of the world for the nominative to be morphologically unmarked (cf. e.g. Blake 1994, p. 31-32), but this is only partly true of Icelandic and e.g. Latin. In particular, the nominative masculine is morphologically marked as compared to the accusative masculine in Icelandic. Thus, any claim to the effect that agreement hinges on morphological unmarkedness immediately breaks down.

I shall here take a somewhat different and a more functional standpoint: The nominative is the “dictionary form” and, more generally, the normal form in isolation and clause-external contexts, as well as the form of predicative NPs. Thus, it may and sometimes must be disambiguated by agreement (under the general conditions of command and “closeness” that apply to matching). In other words, by agreeing with a nominative the functional heads involved signal unmistakably that the nominative belongs to

their domain and is structurally related to them in the relevant manner. – Agreement and nominative may thus be seen as two sides of the same coin.³¹

An approach where T is the locus of nominative case, “nominative in T” for short, might seem to account more straightforwardly for the nominative-agreement correlation. The problem with that approach is, however, that it is descriptively quite inadequate, that is, it is refuted by a whole array of facts. I shall here be concerned with only one type of facts that undermine “nominative in T”, namely various “deep” nominatives that do not correlate with T or verbal inflection at all.

Recall first that Icelandic nominative objects (in the third person) do not trigger number agreement for all speakers, a fact that is straightforwardly accounted for under the present vP case approach. Next, consider the obvious fact that transitive ECM infinitives, like the following, have two accusatives:

(74) We believed [**her** to have seen **them**].

(75) Við töldum [**hana** hafa séð **pá**].
we believed(1pl) her(A) have seen them(A)

As is well known, licensing of a structural accusative is entirely dependent on the presence of a structural nominative in languages like English and Icelandic (cf. e.g. Yip, Maling and Jackendoff 1987, Sigurðsson 1989, Woolford 1997, 2000). Hence, it must be the case that the lower accusative in (74)-(75) is licensed by the presence of a “hidden” nominative (matched by the embedded v*), i.e. a nominative that has been overridden by the matrix accusative, figuratively speaking. This is illustrated in (76):

³¹ Both making DP-internal information (more) visible. – For arguments that nominative is actually “no case”, see e.g. Brandner 1995. Accusative-controlled participle agreement in Icelandic ECM constructions (cf. Sigurðsson 1996) would however seem to raise a problem for the no-case approach to nominative case and so would, presumably, the Nez Perce facts discussed in Woolford 1997. In general, it is quite clear that the familiar nominative-agreement connection is not universal. – I shall not pursue these matters any further here.

(76)

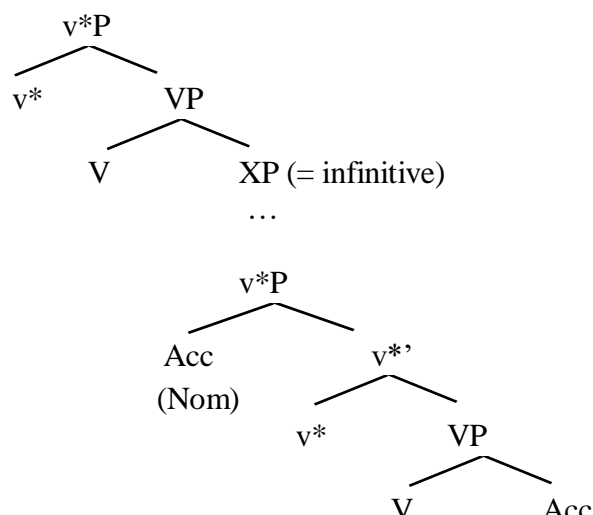

Moreover, nominative objects retain their nominative when embedded under an ECM verb (cf. Jónsson 1996, Schütze 1997), as in (77); obviously the embedded nominative does not enter into any agreement relation (the finite verb agreeing with the matrix subject, as shown):

- (77) Ég taldi [henni ekki hafa leiðst þeir/*þá].
 I believed(1sg) her(D) not have bored they(N)/*them(A)
 ‘I believed her not to have found them boring.’

This property of nominative objects is highlighted by the behavior of certain (mainly psychological) verbs and predicates in Icelandic that can opt for either a nominative or a dative subject, that is, can either show up as Dat-Nom or as Nom-Dat predicates (cf. Barðdal 1999, Platzack 1999).³² This is illustrated in (78) for the verb *henta* ‘suit, be suitable, fit’:

- (78) a **Hún** hafði hentað **honum** vel.
 she(N) had suited him(D) well
 b **Honum** hafði hentað **hún** vel.
 him(D) had suited she(N) well
 ‘She/(It) had suited him well.’

³² Most of the verbs and predicates in question show a slight preference for the Dat-Nom pattern, it seems. – *Leiðast* ‘find boring’ and *líka* ‘like’ are of a different type, allowing only the Dat-Nom pattern.

Strikingly, the nominative in these case patterns behaves differently when embedded under an ECM verb, that is, the Nom-Dat pattern shifts into Acc-Dat, as expected, whereas the Dat-Nom pattern is retained.

- (79) a Við töldum [**hana**/*hún hafa hentað honum vel].
 we believed(1pl) her(A)/*she(N) have suited him(D) well
 ‘We believed her(/it) to have suited him well.’
- b Við töldum [honum hafa hentað **hún**/*hana vel].
 we believed(1pl) him(D) have suited she(N)/*her(A) well
 ‘We believed her(/it) to have suited him well.’

Apart from the object’s case, (79a) is of course parallel to the common pattern in (74)-(76) above, with Nom-X “becoming” Acc-X. The (relevant) structural mechanism of (77) and (79b), on the other hand, is as illustrated in (80):

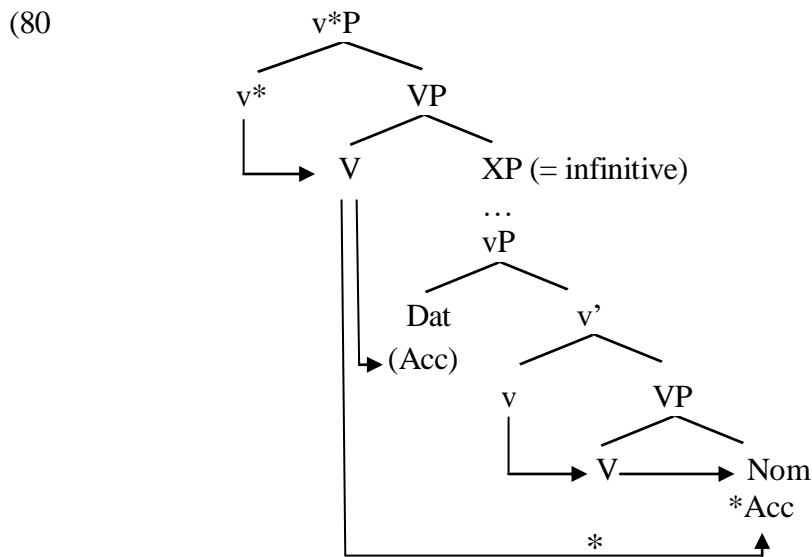

As the accusative of v^* must (vacuosly) match against the dative, it cannot reach the nominative object. Thus, case matching is blocked by Dative-Intervention (a subcase of Relativized Minimality) in the same fashion as Person agreement, cf. (68)-(69) above.³³ – The nominative is

³³ On the other hand, as predicted by the present approach, there is no Dative-Intervention in the Nom-Dat-Acc double object construction (as the accusative case value of v^* is not matched by the indirect dative object). The reason for this difference is structural, but illustrating this would take us too far astray.

straightforwardly accounted for under the present approach, having its source in the infinitival vP (and not entering into any agreement relation).

As is well known, Icelandic raising infinitives allow infinitive-internal nominatives, as in (81):³⁴

- (81) a Okkur virtist/virtust [**þeir** hafa verið gáfaðir].
us(D) seemed(3sg/3pl) they(N) have been intelligent
'It seemed to us that they were/had been intelligent.'
b Okkur sýndist/sýndust [hafa verið veiddir **fjórir fiskar**].
us(D) appeared(3sg/3pl) have been caught four fishes(N)
'It appeared to us that four fishes had been caught.'

As seen, the finite verb may optionally agree (in number only) with the infinitive internal nominatives, and hence they do not pose an obviously acute problem to the “nominative in T” approach (nor do they lend any support to that approach). It is nevertheless clear that these facts are precisely as expected under the present vP case shell approach. More interestingly, Dat-Nom structures may be embedded under raising verbs, provided that the nominative objects do *not* trigger finite verb agreement, as illustrated in (82) and (83):³⁵

- (82) Okkur virtist/*virtust [henni hafa leiðst **þeir**].
us(D) seemed(3sg/*3pl) her(D) have bored they(N)
'It seemed to us that she had found them boring.'
(83) Okkur sýndist/*sýndust [honum hafa hentað **pennarnir** vel].
us(D) appeared(3sg/*3pl) him have suited pens-the(N) well
'It appeared to us that the pens had suited him well.'

As we have seen, structural case matching is blocked by Dative-Intervention. Thus, it seems quite clear that “deep” nominatives in

³⁴ For a more thorough discussion of facts of this sort, see Sigurðsson 1996 (and some of the references there).

³⁵ However, if the embedded Dat-Nom construction is passive, then agreement becomes acceptable to at least some speakers, arguably because of case, gender and number agreement of the participle, the participle thus extending the agreement path, thereby circumventing Relaxed Minimality.

examples of this sort do not relate to the matrix T, that is, examples of this sort speak strongly in favor of the vP case shell hypothesis.

The blocking of finite verb agreement with these “deep” nominatives is also expected (under both the “nominative in T” and the vP case approach), as illustrated below:

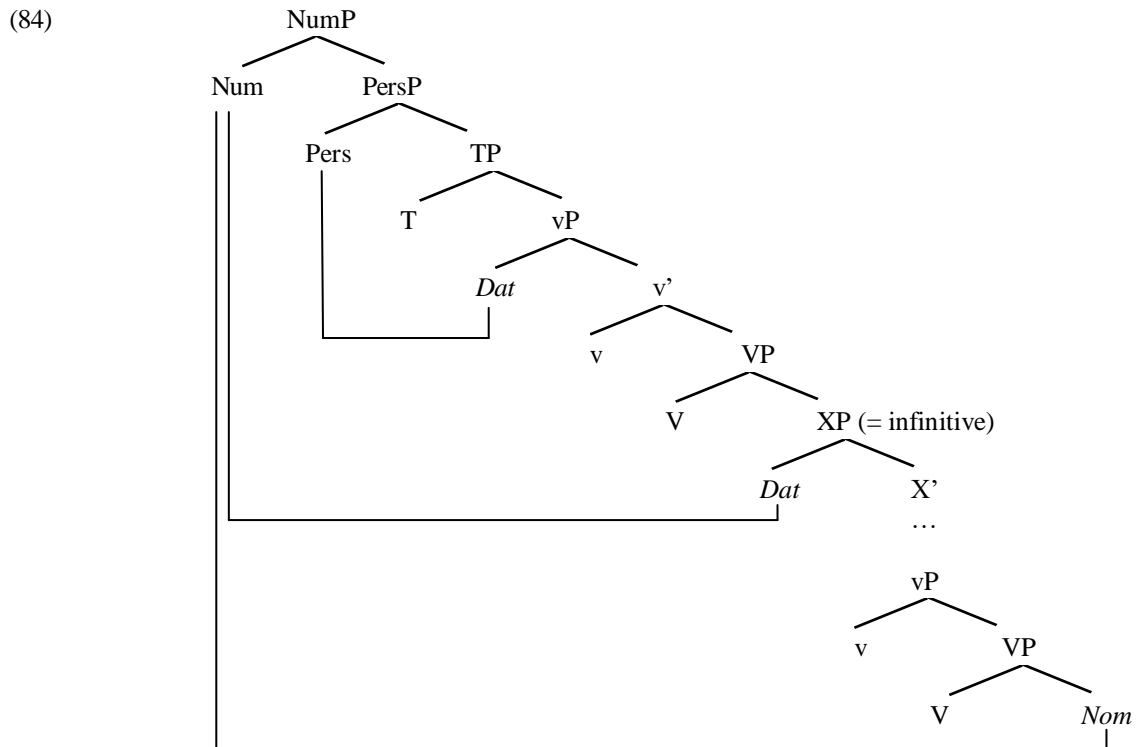

Number matching differs from Person matching in being able to cross or get around one intervening dative. As seen, however, even Number matching cannot get around two such “interveners”.

Yet another piece of evidence in favor of the vP case shell comes from PRO infinitives like the following (cf. Sigurðsson 1991):

- (85) a Strákunum leiddist [að vera ekki **allir** í sama liðinu].
 boys-the(D) bored to be not all(Npl.m) in same team-the
 ‘The boys found it boring no te be all on the same team.’
 b [Að vera ekki **allir** í sama liðinu] er/væri leiðinlegt.
 to be not all(Npl.m) in same team-the is/would-be boring

In addition, as expected, the dative of the Dat-Nom construction is “silent” in PRO infinitives, whereas the nominative is spelled out:

- (86) Mig langaði ekki til að leiðast **þessi stelpa**/*þessa stelpu.
 me(A) longed not for to bore this girl(N/*A)
 ‘I didn’t want to find this girl boring.’

Finally, consider the fact that (standard or formal) Icelandic has a case split reciprocal, such that the “*each-part*” normally shows up with the same case as the subject of the clause, whereas the “*other-part*” has either a verbal or a prepositional object case (cf. Sigurðsson 1994, Eythórsson 1999), as for instance in (87):

- (87) Þeir hafa alltaf dáð **hvor** *annan*.
 they(N) have always admired each(N) other(A)

The relevant fact for our purposes is this: Even though *hver* “each” is nominative, it is consistently lower than the main verb. More examples are given in (88):

- (88) a Þeir hafa alltaf metið **hvor** *annan* mjög mikils.
 they(N) have always appreciated each(N) other(A) very much(G)
 b Þeir mundu aldrei hafa heilsað **hvor** *öðrum* í veislunni.
 they(N) would never have greeted each(N) other(D) in party-the
 c Þeir hafa oft talað vel **hvor** um *annan* við mig.
 they(N) have often spoken well each(N) about other(A) with me

The word order facts are accounted for on the assumptions that *hver* is “stranded” at the edge of vP and that the main verb raises across it, leaving its complement behind (cf. the discussion in Eythórsson 1999; on “short” main V movement, see also Josefsson & Platzack 1998). If so, the nominative *hver* is unmistakably vP-internal.

The idea that nominative case should be inherently related to T is conceptually suspect. First, nominative is cross-linguistically quite commonly the case of DPs in isolation and other clause-external contexts (Blake 1994, p. 31), a fact that would be peculiar if nominative case is contingent upon T.

Second, case serves the major purpose of making DPs (more) visible to their syntactic surrounding. It is certainly rather odd to think of this visibility function as being (partly) limited to tensed environments: what would be the rationale of such a limitation?

In sum, the vP case approach seems not only empirically more adequate than the “nominative in T” approach but also conceptually appealing on both minimalistic and more general premises.

6. Conclusions and extensions

Both case and agreement show quite variable behavior in the languages of the world (cf. e.g. Blake 1994, Julien 2000, chapter 7). Thus, for instance, some languages have multiple verb agreement – suggesting that any DP may in principle match its specific agreement heads in clausal structure – and there are also languages that do not have any morphological markers of agreement and/or case. Thus, the question arises whether these phenomena are components of Universal Grammar. The answer is partly a trivial one, namely that any grammaticalized category in any language must in some sense be an exponent of a universal property (even the less commonly grammaticalized ones like for instance politeness categories). However, deciding whether a category is a universal in itself or whether it is a “superficial” exponent of a “deeper” and a more general property of language is not a trivial undertaking. Abstract case, for instance, seems to be a “deeper” language property than morphological case, being expressed by not only morphological case but also certain stress and intonation strategies. Accordingly, case-poor and caseless languages have more or less the same expressive power as rich case languages, “compensating” for lack of case by means of noninflectional PF strategies.

Agreement is closely related to EPP (cf. e.g. Alexiadou & Anagnostopoulou 1998, Chomsky 1999, Holmberg 2000a, Roberts & Roussou 2000). EPP can be seen as a general requirement that the edge of the clause be lexically visible (Platzack 1998), whereas agreement links DPs to the verbal system of the clause and “transports” DP-internal information to or towards its edge (thereby relating that information to the clause-external context, much like NP-movement does, by more radical means). These two strategies often conflate, but it is not evident that they are exponents of one and the same fundamental property of language.

In view of these considerations it is not obvious that agreement heads as such are universals rather than a reflection of some deeper and more general language property X. Put differently: All languages have property X, commonly or perhaps universally embodied as specific agreement heads.

Consider another but a closely related topic. Complex verb inflection raises the obvious question of whether the finite verb visualizes or represents only one functional head hosting many features, or many heads, each hosting only one feature. More generally: Does language opt for compact heading or for distributed heading? The issue has been widely discussed since Pollock (1989) first proposed the split-Infl hypothesis, see for instance Halle & Marantz (1993), Holmberg & Platzack (1995), Chomsky (1995, 1998, 1999), Thráinsson (1996), Rizzi (1997), Platzack (1998), Bobaljik & Thráinsson (1998), Cinque (1999), Julien (2000) and many others.

Isolating and in general analytic languages would seem to suggest distributed heading, whereas compact heading would at first sight appear to be the null-hypothesis for fusional languages (cf. Thráinsson 1996). Interestingly, however, our study of case and agreement in Icelandic illustrates (or at least strongly suggests) that even highly inflectional and

fusional languages like Icelandic opt for distributed heading – hence the “multiple divorce” of case, number, person and tense we have observed.

This would be a striking and a most surprising result if languages freely opt for either distributed or compact heading. Instead, let us assume that distributed heading is a fundamental property of UG, compact heading thus not being available in narrow syntax (as opposed to PF). If so, UG comprises the *Feature Uniqueness Principle*:

- (89) Any formal feature of UG is represented by a single functional head and any functional head of UG uniquely represents a single formal feature.

Indeed, given straightforward minimalistic assumptions, it must be the case that a formal feature *is* a functional head and vice versa. – It should be kept in mind, however, that many features are complex entities, comprising more than one values (such as [+1p, - 2p]).

It is obviously not a logical necessity that distinct features should be glued together under one and the same functional head, say, for instance, person and tense, or number and mood, gender and person, and so on. As a matter of fact, these and many other features are grouped together differently in different languages. Thus, for instance, person and number show up on the negation in Finnish and not on the verb (as they do in non-negated clauses, on the other hand):

- (90) a Tanssitte.
(you) danced(2pl)
b Ette tanssineet.
not(2pl) danced(perf)

Different grouping and/or fusion of formal features in different languages is plausibly not a property of narrow syntax but brought about by cross-linguistically varying strategies at PF (phonology and morphology in the usual sense), PF thus being much more “syntactic” than usually believed (cf. e.g. Halle & Marantz 1993). This discrepancy between narrow syntax

and PF accounts for the variation and tension between fusional and isolating strategies, both within individual languages and cross-linguistically.

Chomsky (1999, p. 2) formulates the *Uniformity Principle* as follows:

- (91) In the absence of compelling evidence to the contrary, assume language to be uniform, with variety restricted to easily detectable properties of utterances.

Let us assume the understanding that “variety restricted to easily detectable properties of utterances” is “surface” variety, confined to PF. If so, the Feature Uniqueness Principle and distributed heading follow directly (compact heading, on the other hand, being a property of PF, hence cross-linguistically varying). Thus, we come to the radical but logical conclusion that *all* linguistic variation, including parameter settings, is on the PF side (which means that PF must have access to some “syntactic” information).³⁶ Obviously, however, not all features of UG are equal, that is, some features (e.g. [-sg]) are more often and more prominently grammaticalized by PF means than others (e.g. [+polite]). Also, some features (e.g. number and gender) tend to “stick together” more often than others (e.g. mood and gender). It will clearly be one of the major tasks of linguistic inquiry in the near future to identify universal features and explore their hierarchical interrelations and their exponents in the morphology of the languages of the world.

³⁶ See also Roberts & Roussou (1999) for much the same conception of language variation.

References

- Alexiadou, Artemis, & Elena Anagnostopoulou. 1998. Parametrizing Agr: v-movement, word order and EPP-checking. *Natural Language and Linguistic Theory* 16, 491-539.
- Anderson, Stephen R. 1982. Where's Morphology? *Linguistic Inquiry* 13, 571-612.
- Arad, Maya. 1999. On "little v". *MIT Working Papers in Linguistics* 33.
- Barðdal, Jóhanna. 1999. The dual nature of Icelandic psych-verbs. *Working Papers in Scandinavian Syntax* 64, 79-101.
- Bejar, Susana. 2000. Economy, cyclicity and markedness in Georgian verbal morphology. Paper presented at the 23rd GLOW Colloquium, Vitoria-Gasteiz, Spain.
- Belletti, Adriana. 1988. The Case of Unaccusatives. *Linguistic Inquiry* 19, 1-34.
- Blake, Barry J. 1994. *Case*. Cambridge University Press, Cambridge.
- Bobaljik, Jonathan, & Dianne Jonas. 1996. Subject positions and the role of TP. *Linguistic Inquiry* 27, 195-236.
- Bobaljik, Jonas, & Höskuldur Thráinsson. 1998. Two heads aren't always better than one. *Syntax* 1, 37-71.
- Boeckx, Cedric. 1998. Agreement constraints in Icelandic and elsewhere. *Working Papers in Scandinavian Syntax* 62, 1-35.
- Brandner, Ellen. 1995. *Specifiers and Functional Projections*. Doctoral dissertation, University of Stuttgart.
- Chomsky, Noam. 1981. *Lectures on Government and Binding*. Foris, Dordrecht.
- Chomsky, Noam. 1986. *Barriers*. MIT Press, Cambridge, Massachusetts.
- Chomsky, Noam. 1995. *The Minimalist Program*. MIT Press, Cambridge, Massachusetts.
- Chomsky, Noam. 1998. Minimalist inquiries: the framework. *MIT Working Papers in Linguistics* 15.
- Chomsky, Noam. 1999. Derivation by phase. *MIT Occasional Papers in Linguistics* 18.
- Cinque, Guglielmo. 1999. *Adverbs and Functional Heads: A Cross-Linguistic Perspective*. Oxford University Press, Oxford.
- Eythórsson, Þórhallur. 1999. VP order and clausal architecture in diachrony. Paper presented at the 13th Comparative Germanic Syntax Workshop, Lund, January 1999.
- Falk, Cecilia. 1993. *Non-referential Subjects in the History of Swedish*. Doctoral dissertation, University of Lund.
- Haider, Hubert. 2000. Adverb placement – convergence of structure and licensing. Ms., University of Salzburg.
- Halle, Morris, & Alec Marantz. 1993. Distributed morphology. In K. Hale & S. J. Keyser (eds.): *The View from Building 20*, pp. 111-176. MIT Press, Cambridge, Massachusetts.
- Holmberg, Anders. 1993. Two subjects positions in IP in Mainland Scandinavian. *Working Papers in Scandinavian Syntax* 52, 29-41.
- Holmberg, Anders. 2000a. Scandinavian stylistic fronting: how any category can become an expletive. To appear in *Linguistic Inquiry*.
- Holmberg, Anders. 2000b. Expletives and agreement in Scandinavian passives. Ms., to appear in this volume.
- Holmberg, Anders & Urpo Nikanne. 1999. Expletives, subjects and topics in Finnish. Ms., University of Tromsø & University of Oslo.
- Holmberg, Anders, & Christer Platzack. 1985. *The Role of Inflection in Scandinavian Syntax*. Oxford University Press, Oxford.
- Jayaseelan, K. A. 2000. IP-internal Topic and Focus Phrases. Ms., to appear in *Studia Linguistica*.

- Jónsson, Jóhannes Gísli. 1996. Clausal Architecture and Case in Icelandic. Doctoral dissertation, University of Massachusetts.
- Jónsson, Jóhannes Gísli. 1999. S-adverbs in Icelandic: adjuncts or specifiers? Ms. University of Iceland.
- Jónsson, Jóhannes Gísli. 2000. Not so quirky: on lexical (subject) case in Icelandic. Paper presented at the Annual Meeting of the German Linguistics Society, the Case Workshop, Marburg, March 1-3 2000.
- Josefsson, Gunlög, & Christer Platzack. 1998. Short raising of V and N in Mainland Scandinavian. . *Working Papers in Scandinavian Syntax* 61, 23-52.
- Julien, Marit. 2000. *Syntactic Heads and Word Formation*. Doctoral dissertation, University of Tromsø.
- Lasnik, Howard. 1992. Case and expletives. *Linguistic Inquiry* 23, 381-405.
- Maling, Joan, & Rex A. Sprouse. 1995. Structural case, specifier-head relations, and the case of predicate NPs. In H. Haider, S. Olsen & S. Vikner (eds.), *Studies in Comparative Germanic Syntax*. Kluwer, Dordrecht, pp. 167-186.
- Nielsen, Øystein. 1997. Adverbs and A-shift. *Working Papers in Scandinavian Syntax* 59, 1-31.
- Pesetsky, David. 1989. Language-particular processes and the Earliness Principle. Ms., MIT.
- Platzack, Christer. 1998. A visibility condition for the C-domain. *Working Papers in Scandinavian Syntax* 61, 53-99.
- Platzack, Christer. 1999. The subject of Icelandic psych-verbs: a minimalist account. *Working Papers in Scandinavian Syntax* 64, 103-115.
- Platzack, Christer, & Anders Holmberg. 1989. The role of Agr and finiteness. *Working Papers in Scandinavian Syntax* 43, 51-76.
- Pollock, Jean-Yves. 1989. Verb-movement, universal grammar and the structure of IP. *Linguistic Inquiry* 20, 365-424.
- Richards, Norvin. 1998. The Principle of Minimal Compliance. *Linguistic Inquiry* 29, 599-629.
- Rizzi, Luigi. 1997. The fine structure of the left periphery. In L. Haegeman (ed.), *Elements of Grammar. Handbook in Generative Syntax*, Kluwer, Dordrecht, pp. 281-337.
- Roberts, Ian, & Anna Roussou. 1999. A formal approach to “grammaticalization”. *Linguistics* 37-6, 1011-1041.
- Roberts, Ian, & Anna Roussou. 2000. The EPP as a Condition on Tense Dependencies. Ms., to appear in P. Svenonius (ed): *Subjects, Expletives and the EPP*.
- Schütze, Carson T. 1997. *Infl in Child and Adult Language: Agreement, Case and Licensing*. Doctoral dissertation, MIT.
- Sigurðsson, Halldór Ármann. 1989. *Verbal Syntax and Case in Icelandic*. Doctoral dissertation, University of Lund.
- Sigurðsson, Halldór Ármann. 1991. Icelandic case-marked PRO and the licensing of lexical arguments. *Natural Language and Linguistic Theory* 9, 327-363.
- Sigurðsson, Halldór Ármann. 1992. The Case of Quirky Subjects, *Working Papers in Scandinavian Syntax* 49, 1-26
- Sigurðsson, Halldór Ármann. 1994. Ókurteist fornafn [An Impolite Pronoun]. *Jónína hans Jóns Friðjónssonar*, Festschrift for Jón Friðjónsson, pp. 38-49, University of Iceland, Reykjavík.
- Sigurðsson, Halldór Ármann. 1996. Icelandic finite verb agreement. *Working Papers in Scandinavian Syntax* 57, 1-46.

- Svenonius, Peter. 2000. Subject positions and the placement of adverbials. Ms., University of Tromsø.
- Taraldsen, Knut Tarald. 1994. Reflexives, pronouns, and subject / verb agreement in Icelandic and Faroese. *Working Papers in Scandinavian Syntax* 54:43-58.
- Taraldsen, Knut Tarald. 1995. On agreement and nominative objects in Icelandic. In H. Haider, S. Olsen and S. Vikner (eds.), *Studies in Comparative Germanic Syntax*. Kluwer, Dordrecht, pp. 307-327.
- Thráinsson, Höskuldur. 1996. On the (non-)universality of functional categories. In W. Abraham, S. Epstein, H. Thráinsson & J.-W. Zwart (eds.): *Minimal Ideas*. John Benjamins, Amsterdam, pp. 253-281.
- Vangsnes, Øystein Alexander. 1999. *The Identification of Functional Architecture*. Doctoral dissertation, University of Bergen.
- Vikner, Sten. 1995. *Verb Movement and Expletive Subjects in the Germanic Languages*. Oxford University Press, Oxford.
- Woolford, Ellen. 1997. Four-way case systems: ergative, nominative, objective and accusative. *Natural Language and Linguistic Theory* 15, 181-227.
- Woolford, Ellen. 2000. Deriving the (effects of) Burzio's Generalization. Paper presented at the Annual Meeting of the German Linguistics Society, the Case Workshop, Marburg, March 1-3 2000.
- Yip, Moira, Joan Maling & Ray Jackendoff. 1987. Case in Tiers. *Language* 63, 217-250.
- Zaenen, Annie, Joan Maling & Höskuldur Thráinsson. 1985. Case and grammatical functions: the Icelandic passive. *Natural Language and Linguistic Theory* 3, 441-483.

Institute of Linguistics
 University of Iceland
 and
 Department of Scandinavian Languages
 University of Lund, Helgonabacken 14
 SE-223 62 Lund

halldor.sigurdsson@nordlund.lu.se