



LUND UNIVERSITY

Activity Report: Automatic Control 2004

Tuszynski, Agneta; Hagander, Per

2005

Document Version:

Publisher's PDF, also known as Version of record

[Link to publication](#)

Citation for published version (APA):

Tuszynski, A., & Hagander, P. (Eds.) (2005). *Activity Report: Automatic Control 2004*. (Annual Reports TFRT-4032). Department of Automatic Control, Lund Institute of Technology (LTH).

Total number of authors:

2

General rights

Unless other specific re-use rights are stated the following general rights apply:

Copyright and moral rights for the publications made accessible in the public portal are retained by the authors and/or other copyright owners and it is a condition of accessing publications that users recognise and abide by the legal requirements associated with these rights.

- Users may download and print one copy of any publication from the public portal for the purpose of private study or research.
- You may not further distribute the material or use it for any profit-making activity or commercial gain
- You may freely distribute the URL identifying the publication in the public portal

Read more about Creative commons licenses: <https://creativecommons.org/licenses/>

Take down policy

If you believe that this document breaches copyright please contact us providing details, and we will remove access to the work immediately and investigate your claim.

LUND UNIVERSITY

PO Box 117
221 00 Lund
+46 46-222 00 00

Activity Report

Automatic Control

2004



LUND INSTITUTE OF TECHNOLOGY
Lund University

Mailing address

Department of Automatic Control
Lund Institute of Technology
Box 118
SE-221 00 LUND SWEDEN

Visiting address

Institutionen för Reglerteknik
Lunds Tekniska Högskola
Ole Römers väg 1, Lund

Telephone

Nat 046-222 87 80
Int +46 46 222 87 80

Fax

Nat 046-13 81 18
Int +46 46 13 81 18

Generic email address

control@control.lth.se

WWW and Anonymous FTP

<http://www.control.lth.se>
<ftp://ftp.control.lth.se/pub>

The report was edited by Agneta Tuszyński and Per Hagander

Printed in Sweden
Universitetstryckeriet, Lund, June 2005

ISSN 0280-5316
ISRN LUTFD2/TFRT--4032--SE

Contents

1. Introduction 5
2. Internet Services 7
3. Economy and Facilities 9
4. Education 17
5. Research 21
6. External Contacts 57
7. Looking Back – Looking Forward 61
8. Dissertations 83
9. Honors and Awards 89
10. Personnel and Visitors 91
11. Staff Activities 95
12. Publications 109
13. Reports 117
14. Lectures by the Staff outside the Department 123
15. Seminars at the Department 131

1. Introduction

This report covers the activities at the Department of Automatic Control at Lund Institute of Technology (LTH) from January 1 to December 31, 2004. The budget for 2004 was 26 MSEK. The proportion coming from the University was 58%.

Three PhD theses were defended this year, by Stefan Solyom, Johan Bengtsson, and Henrik Sandberg. This brings the total number of PhDs graduating from our department to 71. Two Licentiate theses were completed, by Tomas Olsson and Jenny Ekvall. One new PhD student has been admitted during the year: Isolde Dressler. Two persons with doctor's degree left the department: Bo Lincoln started to work for Combra Syd AB in Lund and Magnus Gäfvert started to work for Haldex AB in Landskrona. Bo Bernhardsson, one of our professors, is on temporary leave working for Ericsson Mobile Platforms AB, Lund. From June Bo is working part time at our department.

In the civilingenjör (master) program we have 12 courses. The total number of students who finished the courses were 950, and 24 students completed their master theses. The total teaching effort corresponds to 147 full-year equivalents.

Research at the department is presented under the following headlines: Nonlinear, Hybrid, and Distributed Systems, Modeling and Simulation, Process Control, Biotechnology Processes, Robotics, Real-Time Control, Biomedical Systems, and Automotive Systems.

Today the department has seven professors and one professor emeritus.

Some statistics from five years is given in the table below.

Introduction

	00	01	02	03	04	Sum
Books	0	0	1	4	0	5
Papers	18	16	21	13	17	85
Conference papers	37	20	44	31	39	171
PhD theses	3	2	1	5	3	14
Licentiate theses	1	1	3	4	2	11
Master theses	24	23	18	19	17	102
Internal reports	5	5	7	2	7	34

Acknowledgements

We want to thank our main sponsors: ABB, Alfa Laval, EU Commission, Haldex AB, Johnson Controls, Inc, STEM, Swedish Energy Agency (CESOST), Swedish Foundation for Strategic Research (SSF), The Swedish Research Council (VR), The Swedish Agency for Innovation Systems (VINNOVA), Toyota Motor Corporation, and Volvo Technology Corporation.

2. Internet Services

World Wide Web

Visit our home-page at this address:

```
http://www.control.lth.se
```

Our web site contains information about personnel, research, publications, seminars, education, etc. It also contains fairly complete lecture notes for many courses, and in some cases software tools such as Matlab tool-boxes developed at the department.

Our home-page first appeared on the World Wide Web (WWW) in April 1994.

Electronic Mail

All personnel can be contacted by electronic mail. A personal email address consists of the full name and the department address, written in the form `FirstName.LastName@control.lth.se`. Double names are separated by underline, hyphens are treated as ordinary characters, and accents are ignored. Examples:

```
karl_johan.astrom@control.lth.se
```

```
bjorn.wittenmark@control.lth.se
```

```
karl-erik.arzen@control.lth.se
```

Our web page <http://www.control.lth.se/people/telemail.html> contains a complete list of email addresses and phone numbers. The department also has a generic email address:

```
control@control.lth.se
```

Emails to this address are continuously read by the postmaster and forwarded to the appropriate receiver.

3. Economy and Facilities

The turnover for 2004 was 26 MSEK. The income comes from Lund University (58%) and from external grants; the distribution is shown below.

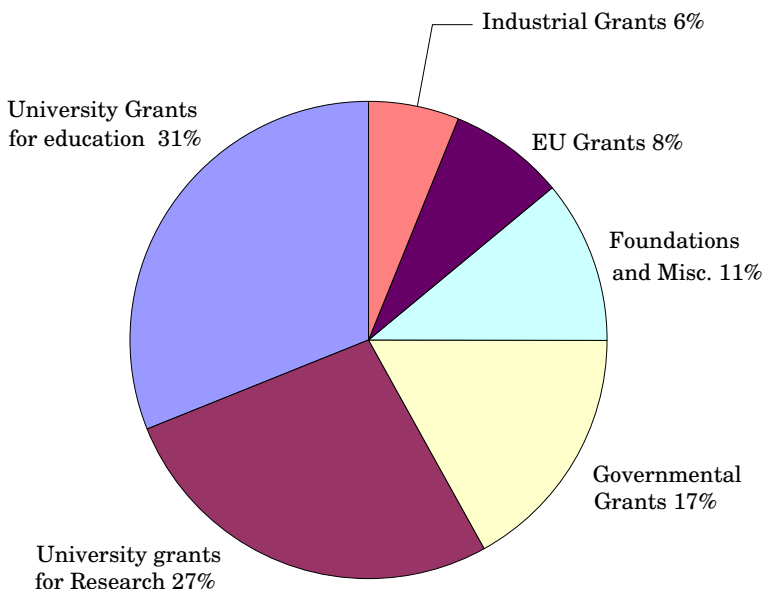

Funding

Lund University provides partial support for graduate students. The majority of our research is, however, externally funded from governmental agencies and industry. During 2004 we had the following contracts:

Economy and Facilities

- VR – Control of Complex and Nonlinear Systems (block grant)
- VR – Industrial Aspects of on-line Monitoring and Diagnosis
- VR – Theory for Modeling, Control and Analysis of Periodic Systems
- VR – Control and Verification of Systems with State Constraints
- VINNOVA – Process Control for Cultivation of Micro Organisms
- VINNOVA – Lund Center for Applied Software Research (LUCAS)
- VINNOVA – Green Car HCCI
- STINT – Funding for research collaboration with Caltech
- SSF – Center for Chemical Process Design and Control (CPDC)
- SSF – Computational Analysis of Dynamical Models
- SSF – Flexible Embedded Control Systems (FLEXcon)
- SSF – Decentralized control of complex systems, Senior Individual Grant, SIG Anders Rantzer
- EU/GROWTH – Advanced Decision Systems for the Chemical/Petrochemical Manufacturing Industries (CHEM)
- EU HPRN-CT – Nonlinear and adaptive control (NACO2)
- EU IST 2001-33520 – Control and Computation (CC)
- EU IST 2001-37652 – Hard Real-time CORBA (HRTC)
- EU IST-004536 – Reconfigurable Ubiquitous Networked Embedded Systems (RUNES)
- EU IST-004175 – Complex Embedded Automotive Control Systems (CEmACS)
- EU IST-004527 – ARTIST2: Embedded Systems Design (ARTIST2)
- EU IST-511368 HYbridCONtrol – Taming Heterogeneity and Complexity of Networked Embedded Systems (HYCON)
- EU IST-507728 EURON II NoE, Member agreement
- ABB Automation Technology Products/Business Unit Robotics (Research Collaboration)
- ABB – PhD Research Project

- Alfa Laval Lund AB – Research and Development Agreement
- Mid Sweden University – PhD Research Project
- Haldex Brake Products AB – PhD Research Project
- Toyota Motor Corporation – Simulation Model
- Swedish Energy Agency (STEM) – Active Control of Combustion Oscillations in Gas Turbines (CECOST)
- Johnson Controls Inc – Scholarship
- Royal Physiographic Society – Scholarship
- Jacob Letterstedt - Scholarship
- Knut and Alice Wallenberg – Scholarship
- Foundation Sigfrid and Walborg Nordkvist – Scholarship
- Foundation Aeryleanska Traveling Scholarship – Scholarship

The block grant from VR and the CPDC grant from SSF are long range and also some of the VINNOVA projects are long range. Several projects do, however, have a duration of only two years. To match these with the duration of a PhD, which is much longer, we have an internal research planning that is much more long range and we are careful to bid on projects that fit our long range research plan. This has proven an effective way to match short-term funding to long-term planning.

Facilities

The main facilities are laboratories and computer systems. Almost all staff use PCs running Linux. Some, especially administrative staff, have a need for Microsoft Windows. In those cases the VMware product enables them to run both Linux and Windows at the same time.

The senior academic staff have laptop computers running either Linux plus VMware/Windows or pure Windows.

Economy and Facilities

There is also a reasonably powerful central computer, which is used for certain types of heavy computations.

Teaching Laboratory

The teaching laboratories are based on desktop processes and personal computers. These laboratories are used in all our courses. The introductory courses give a heavy load on the teaching laboratories because of the large number of students. There are more than 1000 students, and on the average they spend about 20 hours each in the lab.

A certain amount of computer replacement has been done during the year, such that the teaching lab contains 40 PCs, the oldest ones delivered in 2000.

New Lab Equipment and Processes

Controller Design for a Direct Coupled Motor During 2004 Pontus Nordfeldt supervised a project in cooperation with Tetra Pak R&D and the automation company B&R. The project concerned controller design for a direct coupled synchronous 3-phase motor from Tetra Pak. Automation equipment was provided by B&R. The project resulted in three system identification project reports and one master's thesis. See Figure 3.1.

Embedded Processor Modules The department has built a number of embedded processor modules with Atmels AVR RISC-processors. These processor modules uses either Mega8 or Mega16 processors, and has PWM power drivers capable of delivering a maximum of 6 amperes to connected loads. These modules has been used in the Real-Time Systems course, doctorate projects and Master's Theses. See Figure 3.2.

Linear Servo with Inverted Pendulum The linear servo consists of two carts moving on a linear rail and connected by a spring, one driven by a DC motor and the other trailing along holding a pendulum. The PWM control of the DC motor and measurement of absolute position of the driven cart as well as the distance between the carts

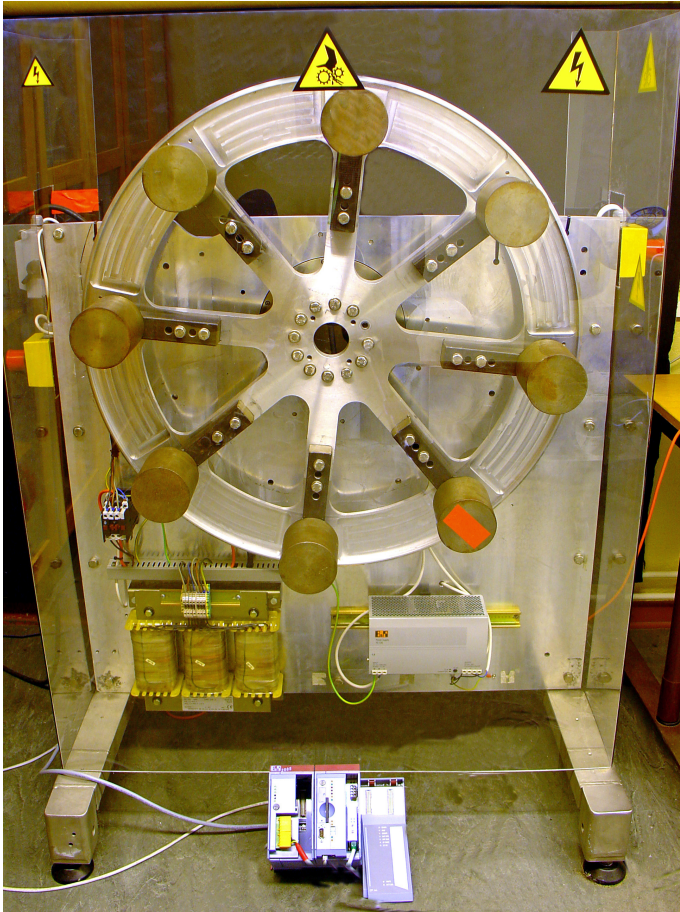

Figure 3.1 Controller design for a direct coupled motor

was done with one of the embedded processor modules built around Atmel AVR Mega8 processors.

Position and distance measurements are done by a linear A/B encoder that consists of black and white stripes, each 2.5 millimeters wide. To get a better resolution, the A/B signals are read by the built-in A/D

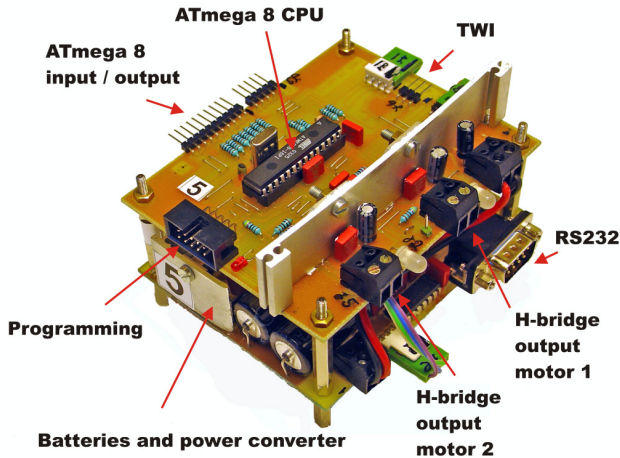

Figure 3.2 Embedded processor module connected to linear servo with inverted pendulum

converters of the Mega8 processor, and the two sinusoid signals are used to interpolate the position with an accuracy better than 0.1 millimeter.

To balance the pendulum upright, the position, distance and pendulum angle measurements are transmitted via RS-232 to a PC running a Real-Time enhanced version of Linux, where calculation of the desired motor current is done by a Matlab/Simulink block. The result is then transmitted back to the processor module, where it is used to control the PWM ratio and direction of the power electronics. See Figure 3.3.

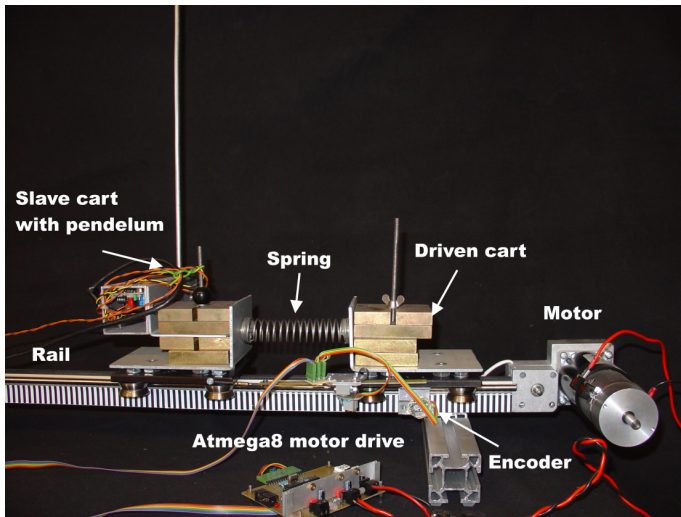

Figure 3.3 Linear servo with inverted pendulum

4. Education

Engineering Program

The engineering education follows the central European systems with a 4.5 year program leading up to the degree “civilingenjör” (civ.ing.), which corresponds to an MSc in the US and British systems.

Automatic control courses are taught as part of the engineering curricula in Engineering Physics (F), Electrical Engineering (E), Computer Engineering (D), Mechanical Engineering (M), Industrial Management and Engineering (I), Chemical Engineering (K), Environmental Engineering (W), and Information & Communication Engineering (C). Our courses are listed in Table 4.1. During 2004, 950 students passed our courses and 24 students completed their master’s thesis projects. The number of registered students corresponded to 147 full-year equivalents during the year. The numbers for 2003 were 913, 21, and 125 respectively.

Information on WWW

Many students have access to Internet via Lund University. Therefore we have made a great effort to present the education on web pages. Each course in the engineering program has its own home-page, where the students can find course plans, lecture notes, documentation, manuals, old exams, etc.

We have also information sheets about the engineering courses and the doctorate program. You find the education links at <http://www.control.lth.se/education/>.

Education

Table 4.1 Courses and the number of students who passed.

Reglerteknik AK–FEDIM <i>FRT010</i> (Automatic Control, basic course)	527
Reglerteknik AK–C <i>FRT065</i> (Automatic Control, basic course)	37
Processreglering (K) <i>FRT081</i> (Automatic Process Control)	21
Systemteknik (W) <i>FRT110</i> (Systems Engineering)	51
Digital Reglering <i>FRT020</i> (Computer-Controlled Systems)	93
Realtidssystem <i>FRT031</i> (Real-Time Systems)	84
Systemidentifiering <i>FRT041</i> (System Identification)	31
Adaptiv reglering <i>FRT050</i> (Adaptive Control)	32
Olinjär reglering och Servosystem <i>FRT075</i> (Nonlinear Control and Servo Systems)	43
Internationell projektkurs i reglerteknik <i>FRT100</i> (International Project Course in Automatic Control)	7
Projekt i reglerteknik <i>FRT090</i> (Project in Automatic Control)	12
Reglerteori <i>FRT130</i> (Control Theory)	12
Examensarbete 20 poäng <i>FRT820</i> (Master-thesis project, 5 months)	24

Doctorate Program

Three PhD theses were defended by Stefan Solyom, Johan Bengtsson, and Henrik Sandberg. This brings the total number of PhDs graduating from our department to 71. Two licentiate theses were completed, by Tomas Olsson and Jenny Ekvall. Abstracts of the theses are given in Chapter 7.

We have admitted one new PhD student during the year, Isolde Dressler.

The following PhD courses were given:

- Stochastic Control (Björn Wittenmark) 5 points
- FRT041F System Modeling and Identification (Rolf Johansson) 3 points
- FRT050F Adaptive System Theory (Rolf Johansson) 3 points
- Control Problems in Mobile Communication (Bo Bernhardsson) 5 points
- Discrete and Hybrid Systems (Karl-Erik Årzén) 5 points
- Control System Syntes (Anders Robertsson) 5+3 points
- Automotive Control System (Anders Rantzer) 2points
- PID Controllers Theory, Design, and Tuning (Tore Hägglund) 4 points
- Process Control Literature Seminars (Tore Hägglund) 2 points

5. Research

The goal of the department is to provide students with a solid theoretical foundation combined with a good engineering ability. This is reflected in the research program which covers both theory and applications.

The major research areas are:

- Nonlinear, Hybrid and Distributed Systems
- Modeling and Simulation
- Process Control
- Biotechnology Processes
- Robotics
- Real-Time Control
- Biomedical Systems
- Automotive Systems

In the following presentation the research is in most cases broken down to the granularity of a PhD thesis. There are of course strong relations between the different projects.

Nonlinear, Hybrid and Distributed Systems

Control of Nonlinear Systems

Researchers: Anders Rantzer, Stephen Prajna and Andreas Wernrud

Current developments in control theory are closely linked to the rapid improvements of computer tools for design, analysis, and simulation. The aim of this project is to pursue this combined development of theoretical and computational tools, and define new directions motivated by applications. Our main investigations deal with stability and robustness analysis as well as controller optimization.

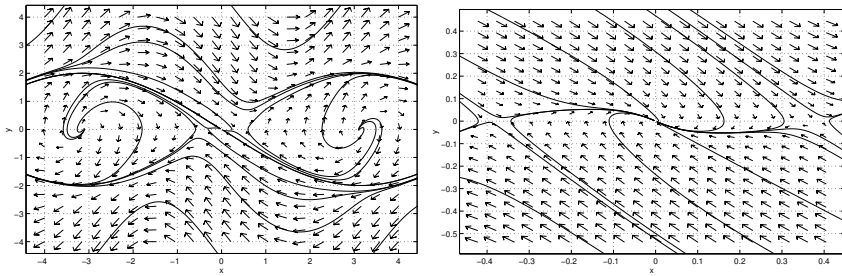

Figure 5.1 Left: Phase plot for smooth pendulum swing-up control. Right: Magnified phase plot near upright equilibrium.

Recently, we reached a remarkable breakthrough in the analysis of nonlinear systems. Most classical analysis methods have been based on Lyapunov functions. This is a very strong theoretical tool, but has important shortcomings in the context of control synthesis. In particular, the set of control Lyapunov functions for a given system is generally non-convex and even disconnected. Our new result gives an alternative approach to stability of nonlinear systems, which can be viewed as a dual to Lyapunov's theory. It is different in the sense that all implications are stated in terms of "almost all trajectories" of the system. Furthermore, the new criterion enjoys a powerful convexity property in control synthesis.

As an application of the new criterion, we have derived the first known globally smooth feedback law for swing-up and stabilization of an inverted pendulum. A two-dimensional phase plot of the closed loop system is shown in Figure 5.1

For several years, we have been developing the analysis framework based on integral quadratic constraints in cooperation with Prof. A. Megretski at MIT. Currently, our work is focused on constraints for time-varying time-delays. This makes it possible to treat performance degradation due to delays in the communication network used for control.

Hybrid Control

Researchers: Peter Alriksson, Bo Lincoln, Stefan Solyom and Anders Rantzer

Hybrid systems is an active research area on the border between Computer Science and Automatic Control. A typical hybrid system consists of a physical process under control and supervision of a discrete computer. Not only computers, but also some physical phenomena are conveniently modeled as discrete events. Examples are mechanical systems with backlash, dead zones, and static friction, or electrical systems with switches. The department is involved in several projects devoted to hybrid control and computational approaches are developed for both analysis and synthesis.

A very promising synthesis approach is currently developed within the project based on classical dynamic programming. This method was introduced by Bellman in the 1950s and has found many important applications since then. The idea is general and very simple, but the "curse of dimensionality" is often prohibitive and restricts most applications to a discrete state space of moderate size.

We have recently initiated a very exciting development based on approximations of the cost function. It turns out that the exponential complexity of traditional dynamic programming algorithms often can be drastically reduced by relaxing the demand for optimality. For example, to find an optimal switch strategy on a graph with 60 nodes, 120 edges and 30 continuous states updated along each edge is generally hopeless, but a solution guaranteed to stay within a factor 4 from the optimal cost can be found in a few seconds. See Figure 5.2.

Distributed Estimation and Control

Researchers: Peter Alriksson, Anton Cervin, Ather Gattami and Anders Rantzer

Significant attention has been given to distributed algorithms for sensing and control, particularly in the context of wireless sensor networks. As the number of sensors in an area increases, the communication limitations imposed by bandwidth constraints becomes more and more evident. It is therefore desirable to limit the communication that takes place at each sampling interval. Also, sensors could be battery powered

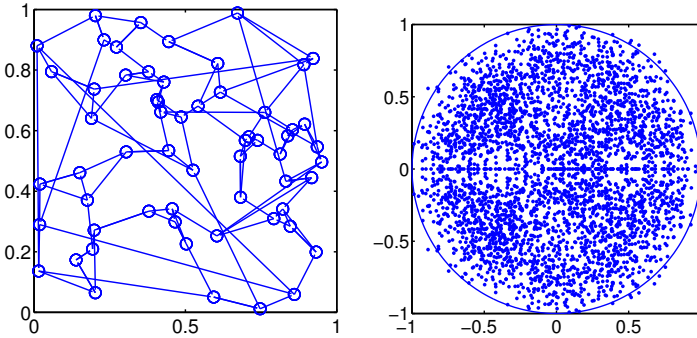

Figure 5.2 A graph with 60 nodes has been randomly generated. From each node, there are two edges defining possible switches. For each of the 120 edges, a 30×30 matrix A_{ij} is used to define the dynamics of the continuous states along that edge. The coefficients of each matrix are randomly generated, but the matrix is scaled to have eigenvalues in a prespecified disc. To the right, all eigenvalues of the 120 A_{ij} matrices are shown.

and then power saving is an essential factor. To save power, a sensor can be put in stand-by mode and then woken by the estimator at certain points in time. There could also be situations where it is impossible to use two sensors at the same time due to the nature of the sensors, ultrasonic sensors is one example.

One aim of this project is to develop algorithms that not only decide how to combine information from different sensors at different points in time, but also how to decide which sensors to use. The objective is to minimize the estimation error, or more generally the performance of a feedback system where information from the sensor network is used. An estimation-method has been developed that operates within a pre-specified distance to optimality.

Another direction of research is focusing on distributed control, i.e. where several cooperating actuators are acting based on locally available information.

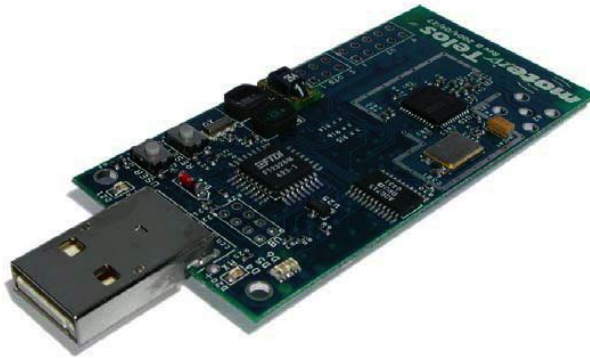

Figure 5.3 Telos Rev B sensor node is used for evaluation of distributed algorithms.

Modeling and Simulation

Reduction and Aggregation of Process Models

Researchers: Henrik Sandberg and Anders Rantzer

The goal of this project is to find methods and tools for simplification of complex nonlinear and time-varying process models. The background is that large complex mathematical models are regularly used for simulation, prediction, and control. However, it is common practice to work with as simple models as possible, because they are easier to analyze and evaluate. This is one reason why there is a strong need for methods and tools that can take a complex model and deduce simple models.

Our approach to model simplification is based on linearization around trajectories. This results in time-varying linear models that capture effects such as frequency coupling (a single frequency in the input gives several frequencies in the output). We use a method called balanced truncation to simplify the time-varying models. Until recently, balanced truncation for time-varying models has only been justified by heuristic

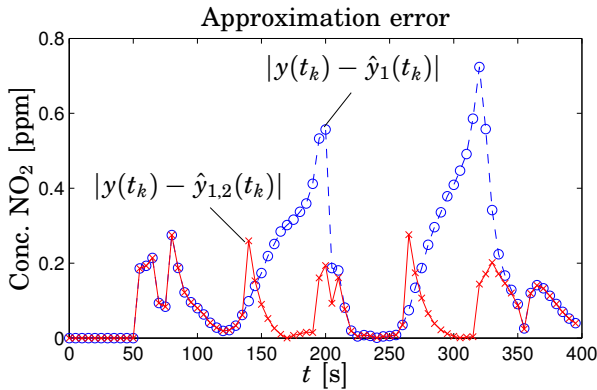

Figure 5.4 The approximation error between a discrete-time system with output y , and two truncated balanced realizations $\hat{y}_{1,2}$ and \hat{y}_1 . The model \hat{y}_1 has only one state, and $\hat{y}_{1,2}$ switches between one and two states. When the complexity of the original model is high, the state dimension of $\hat{y}_{1,2}$ is two. This leads to increased accuracy. There are state-dimension switches at $t = 140, 195, 265, 320$ in $\hat{y}_{1,2}$.

arguments. Based on work done in our group, it is possible to derive various *a priori* error bounds that can guarantee good approximations, and help in the selection of model complexity.

The work has been focused on numerical issues and on models with time-varying complexity in 2004. In Figure 5.4, some results from tests on a diesel exhaust catalyst model are shown. In particular, the benefits of time-varying complexity are demonstrated.

Theory for Modelling, Control, and Analysis of Periodic Systems

Researchers: Henrik Sandberg, Anders Rantzer, Bo Bernhardsson, and Magnus Fontes (Department of Mathematics, Lund Institute of Technology)

The goal of this project is to study models of periodic systems. Periodic systems are common in engineering. Examples include sampled-data

systems, helicopter rotors, wind mills, AC power systems, and electronic oscillators.

The focus of the research at the department is on frequency-domain models of periodic systems. Frequency-domain models, called transfer functions, are often used for analysis of time-invariant systems. It is natural to look for extensions to periodic systems. The frequency-domain models of linear periodic systems become infinite-dimensional operators, called harmonic transfer functions.

Even though the harmonic transfer function formally fulfills many well-known relations for normal transfer functions, the precise meaning and correctness of the formulas are often unknown in the periodic case. The difficulties stem from the fact that the harmonic transfer function is an infinite-dimensional operator. To make computations in practice, it is then important to study the convergence of finite-dimensional approximations.

The work in 2004 has been focused on obtaining convergence rates for finite-dimensional approximations of the harmonic transfer function. We also generalized Bode's sensitivity integral to the periodic domain, see Figure 5.5. This work was awarded with the IEEE CDC 2004 Best Student Paper Award.

Modeling of Automotive Combustion Engines for Toyota

Researchers: Magnus Gäfvert, Oskar Nilsson, Anders Rantzer, in cooperation with Department of Heat and Power Engineering, Division of Combustion Engines.

This is a project supported by Toyota Motor Company. The project was initiated after a sequence of mutual visits by Dr. Akira Ohata from Toyota Motor Company and Prof. Anders Rantzer from Lund University. It was preceded by a smaller project during 2002, where Hubertus Tummescheit developed models for oxygen sensors in the language Modelica. The current project has two components:

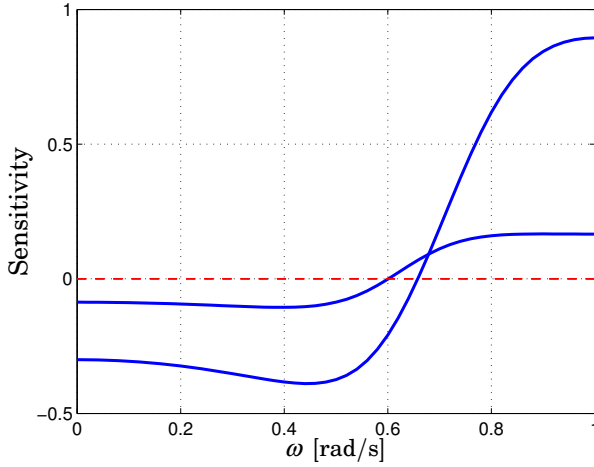

Figure 5.5 The sensitivity for a linear time-periodic system in closed loop obeys certain fundamental limitations. The curves show the sensitivity of the closed-loop system for different frequencies. The generalized Bode sensitivity result says that the area above and below the zero-level must be equal. Hence, if the sensitivity is decreased for low frequencies, it must increase for high frequencies, as seen in the figure. This is called the water-bed effect.

Model validation/calibration for exhaust gas oxygen sensors

This component builds on the work by Tummescheit and the purpose is to verify and improve the model quality by comparing simulations to measurements. It is also desirable to better understand of how various model parameters influence the behavior of the model.

Oxygen sensors, or lambda sensors, are core components in the emission control in modern SI stoichiometric engines. The performance of catalysts are highly dependent on exhaust gas composition and, e.g., the presence of oxygen needs to be precisely controlled. To meet future emission legislations it is required to refine and extend current lambda control strategies. Good understanding of catalyst operation is essential to improve emission performance. It is necessary to understand the interaction of the catalyst and the lambda control system, including

the lambda sensors, to optimize the exhaust gas treatment. Physically based simulation models are then vital tools to analyze and evaluate new control strategies. An important part in this is the sensor models, and their ability correctly reproduce effects of significance to catalyst operation. Of particular interest is the shift in voltage characteristics with respect to oxygen concentration that is observed when the exhaust gas is diluted with hydrogen or carbon Monoxide.

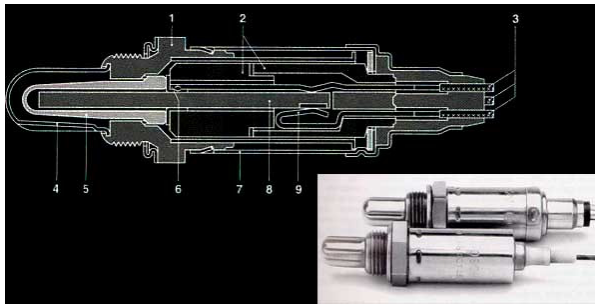

Figure 5.6 A λ -sensor is used to measure the oxygen content in exhaust gases. This feedback signal is needed for proper operation of the catalyst

Development of control design models for an HCCI engine

Here the purpose of modeling is to support feedback control of the combustion timing in an HCCI engine. The models are developed in Modelica and include thermodynamics and simple thermo chemistry.

In homogeneous charge compression ignition (HCCI) engines the ignition timing is defined by the autoignition properties of the air-fuel mixture in use. The autoignition process is determined by chemical kinetics influenced by species concentrations and temperature trace. Small variations in the cylinder environment may greatly influence the ignition timing. Therefore, HCCI engines require precise control to operate with predictable timing and one major difficulty with HCCI engines is to control the moment of autoignition and the energy release rate. In order to arrive at successful control strategies it is necessary to have good models and substantial understanding of the ignition and

Research

combustion process. This project task aims at describing the major thermodynamic and chemical interactions in the course of an engine stroke and their influence on ignition timing. Common strategies for timing control includes variable valve timing, variable compression ratio, or to employ varying the inlet temperature and fuel composition.

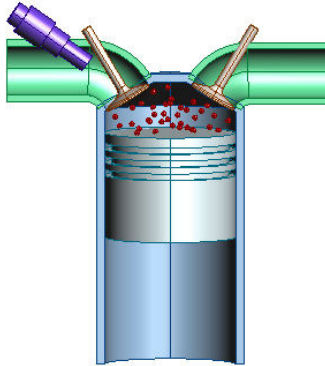

Figure 5.7 In an HCCI engine a homogeneous premixed charge is compressed until autoignition.

Process Control

Control of an Open Plate Reactor

Researchers: Staffan Haugwitz and Per Hagander

The project, which started in September 2002, is run by Alfa Laval AB in collaboration with several other universities and institutes, such as Le Laboratoire de Génie Chimique de Toulouse. The project is funded by Alfa Laval AB and CPDC.

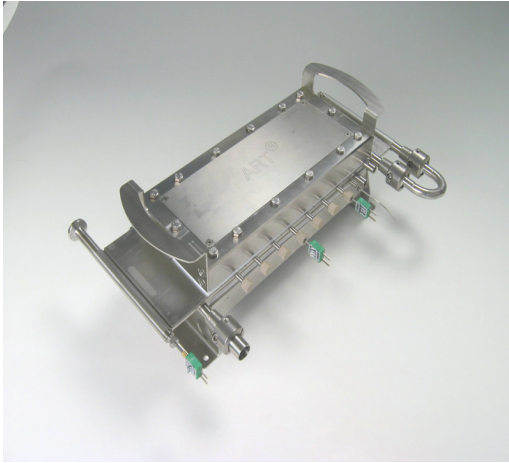
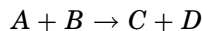

Figure 5.8 A plate reactor for use in small laboratories. Courtesy of Alfa Laval AB.

The Open Plate Reactor (OPR) is a combination of a plate heat exchanger and a chemical reactor, see Figure 5.8. One side is used for chemical reactions and on each side there are cooling/heating plates. Depending on the reaction, there is a need for the water flow to cool or heat the reactor, i.e. if the reaction is exothermic or endothermic.

When the reactions are exothermic and fast, the reactants are often dissolved into low concentration solutions to ensure that the temperature in the tank reactor does not rise above a dangerous level. By using a plate reactor, solutions of higher concentrations can be used, thus increasing the productivity and safety.

The plate reactor can be approximated as a one dimensional tube reactor. A typical reaction can be stated as:



Reactant A enters the plate reactor at the upper left corner, see Figure. 5.9. Reactant B is injected in multiple places along the tube

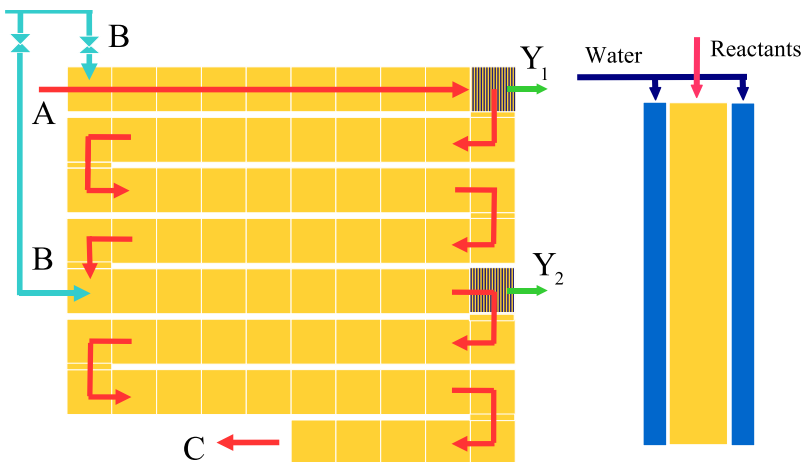

Figure 5.9 Left: A schematic figure of a few rows of a reactor plate. Reactant A is injected at top left and reactant B is injected at multiple sites along the reactor. Y_1 and Y_2 are internal temperature sensors used for process control and supervision. Right: The plate reactor seen from the side with the reactor part surrounded by cooling plates.

reactor, in order to use the entire length of the reactor. When reactant A and B mix, the substances C and D are produced. If the reaction is exothermic, heat is generated and the temperature of the fluid increases. For each injection point, there will be a local temperature maximum. To cool the reactor cold water flows on each side of the reactor. The reactor construction is very flexible, where the number of plates, injection sites and sensor locations can be varied to fit various chemical reactions.

The plate reactor is very interesting from a control point of view. It has internal sensors enabling accurate information about temperature and also indirect concentrations inside the reactor. With multiple injection points the heat generated from the exothermic reactions can be redistributed for an improved safety and performance.

The primary control objective is to guarantee safety in terms of the temperature inside the reactor. In addition the plate reactor should be

controlled so that the reaction yield, that is the chemical efficiency is maximized. The control system should be robust towards disturbances and variations in inlet feed conditions. One crucial part of the control system will be the start-up procedure. The objectives of the control system can be summarized as:

- Utilize reactor maximally in a safe way
- Reaction is to be completed within the reactor
- Reactants are to be in the right proportions
- Should be able to work with highly concentrated solutions
- Avoid side reactions
- Achieve and maintain desired operating conditions
- Fast and safe start-up/shut-down
- Emergency shut-down procedure
- Robustness towards disturbances in the process

A process control system for the reactor has been designed and tested in simulations. Model Predictive Control (MPC) is used to calculate suitable injection flows and cooling temperatures, see Figure 5.10. Reactant injection and cooling temperature controllers are designed separately to be placed in a cascade with the MPC.

A utility system has been designed, which delivers cooling water with desired temperature and flow rate. A temperature controller using a mid-ranging control structure has been developed. The utility system, seen in Figure. 5.11, has been assembled at Alfa Laval facilities in Lund. Experiments to investigate the control properties of the plate reactor and to test the temperature control system have been conducted successfully.

The designed process control system increases the safety of operations by reducing the impact from external disturbances. This will also decrease the risk of unnecessary shutdowns of the process operation.

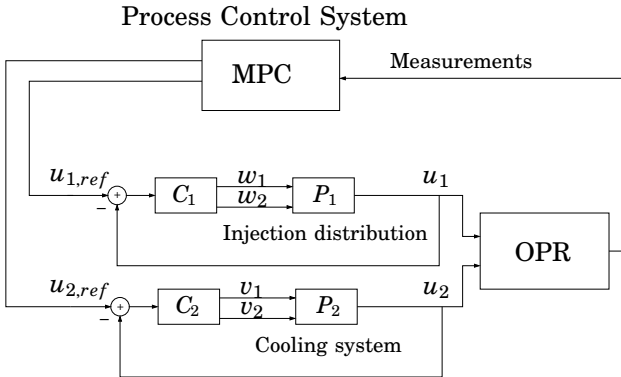

Figure 5.10 Control structure for the OPR. The Process control system uses Model Predictive Control (MPC) to calculate the optimal control signals u_1 and u_2 . These signals are then sent to the injection distribution C_1 and cooling temperature C_2 controllers.

Modeling and Control of the Drying Sections of a Paper Machine

Researchers: Ola Slätteke, ABB and LTH, Björn Wittenmark, and Tore Hägglund, in cooperation with Krister Forsman, ReglerDoktorn AB

The paper making process is essentially a very large drainage process. Consistency of the stock flow entering the paper machine head box is typically around 0.2%–1.0% (2–10 g fiber per kg water). Although the drying section is responsible for removing less than 1% of this water content, this is the part of the paper machine that, by far, consumes most energy. It is also in the drying section where most paper web strength forms and web shrinkage occurs and the part where the actual moisture control is performed. These are some of the reasons why this part of the paper machine is critical for the final paper qualities.

A dryer section in a paper machine can consist of up to one hundred steam heated cylinder and the length of the drying section can be above 100 meters. See Figure 5.12. The cylinders are divided in 5–10 steam groups. The control of the steam pressure in these cylinder groups is in



Figure 5.11 The experimental test unit, with the plate reactor to the left.

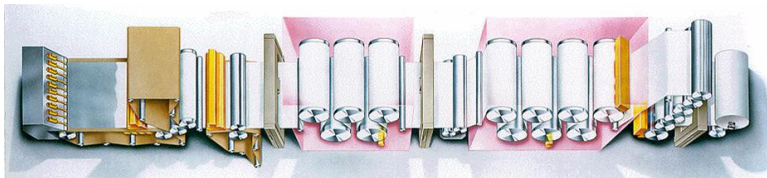

Figure 5.12 Schematic illustration of a paper machine. The direction of the paper production is from left to right. The dryer section, with its steam heated cylinders, is the pink area in the picture.

cascade control with the moisture control loop. This project is focused on the modeling and control tuning of this process. From mathematical model building and experiments on industrial paper machines it is found that the dynamics from the steam valve to the steam pressure in the cylinders can be described by a simple process model, the so called IPZ model. This model has an integrator, one pole, and one zero. The dynamics from the steam pressure set point to the moisture in the

Research

paper can be described by a first order model plus dead time, where the dead time is a dominating part.

A simple tuning method for the pressure controller (a PI-controller) has been developed that is based on the four process parameters of the IPZ model. These process parameters can easily be obtained by a simple open loop step response. The tuning rule has been demonstrated on a few different paper machines in Sweden. Also, a nonlinear model for the steam pressure based on first principles has been developed and verified against real plant data. This model has also been implemented in the Modelica simulation environment for further analysis.

In collaboration with Department of Chemical Engineering in Lund, a new principle of control in the drying section has been examined by simulations. Instead of only using the steam heated cylinders to control the moisture, the air system is also incorporated into the control structure by mid-ranging. Specifically, the dew point and velocity of the air blown onto the paper web is used to control the moisture in the paper while the steam pressure is set at a level where the air system has an adequate control range in both directions. Simulations have given promising results by showing that the bandwidth of the mid-ranging controller is more than twice as large as the conventional controller. At the moment, a feedforward structure to further improve the performance of the moisture control loop is examined. A new measured signal is proposed for the feedforward that is based on the surface temperature of the paper web. Preliminary results show a good potential.

Advanced Decision Support Systems for the Chemical/Petrochemical Manufacturing Industries (CHEM)

Researchers: Karl-Erik Årzén, Johan Åkesson, Rasmus Olsson

The aim of the EU/GROWTH project CHEM (<http://www.chem-dss.org>) was to develop an integrated set of toolboxes for various operator support functions in the process industries. CHEM started April 1, 2001 and ended 31 March 2004. The partners within CHEM were: Institut Francais de Petrol, France (Coordinator), Corus (ex. British Steel), UK, Computas, Norway, Gensym, France, KCL, Finland, LAAS,

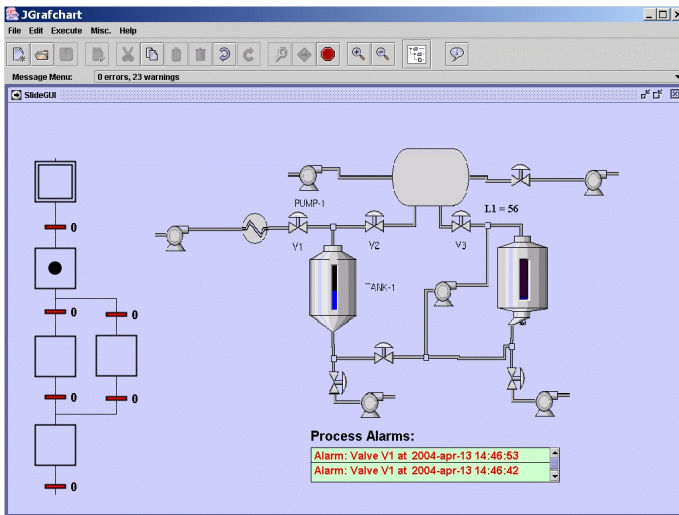

Figure 5.13 Screen-shot of JGrafchart

Toulouse, France, LAG, Grenoble, France, Lund University, Metso Automation, Finland, Thales (ex Thomson), France, Universitat Politècnica de Catalunya, Spain, Université des Sciences et Technologies de Lille (LAIL), France, Universitat de Girona, Spain, UPM Kymmene, Finland, VTT Automation, Finland, Warsaw University of Technology, Poland, and ZAP, Poland.

The Department of Automatic Control was responsible for the development of an operating procedure handling toolbox that can be used to support the operators in process state transitions. The toolbox is named JGrafchart and consists of graphical procedure language editor and its associated runtime system. The JGrafchart language combines ideas from Grafset/Sequential Function Charts, Statecharts, and object-oriented programming. JGrafchart is implemented in Java and Swing. A screenshot of JGrafchart is shown in Fig. 5.13. JGrafchart is publically available.

Within CHEM the department was also investigating the possibility

Research

to use numerical optimization techniques for grade change sequence generation.

Control and Diagnosis in Batch Processes

Researchers: Rasmus Olsson and Karl-Erik Årzén

The aim of this project is to study integrated information and control systems for batch production. Special emphasis is put on integration of the monitoring and supervision tasks with recipe-based production. Two main issues is under investigation. The first issue studies the interaction between recipe execution and supervision. A model-based approach is taken where an internal unit model is used to check the validity of the unit operations in the recipes on-line. The internal unit model will also be used to structure the representation of the basic interlocking logic for safety monitoring. The second issue concentrates on the use of historical data in monitoring and supervision of batch process.

The work in the first part of the project is a continuation of the work on recipe-based batch processes by Charlotta Johnsson. The work is based on JGrafchart, a graphical sequential programming language that and its applications to batch recipe management and resource allocation. The focus of this part of the project is to extend JGrafchart by adding different features that support exception handling in batch production.

A collaboration has been started with Prof. Puigjaner's group at UPC in Barcelona. Our results have been applied to the PROCEL batch laboratory process at UPC. Our approach is integrated with the reactive batch scheduling software developed at UPC. Part of this work is financed by the CHEM EU project.

During 2004 the focus has been on developing methods for combining model-based approaches and multi-variate statistical methods for fault detection in chemical batch reaction processes.

PID Control

Researchers: Karl Johan Åström and Tore Hägglund

This project has been in progress since the beginning of the eighties, and resulted in industrial products as well as several PhD theses. Several monographs on PID control that are based on experiences obtained in the project have also been published.

In the PhD theses *PID Control – Design, Extension, Application* by Héléne Panagopoulos, efficient design methods for PID controllers were presented. These methods are based on constrained optimization and require that a process transfer function is available.

During the last years, these design methods have been used to develop simple tuning rules that are based on simple process models obtained step or frequency response experiments. The design rules are named AMIGO (Approximate M-constrained integral gain optimization). A sequence of five papers have been written that treat PI and PID control based on step and frequency response methods, and a combination of step and frequency responses.

Control and Supervision at Grade Changes

Researchers: Jenny Ekvall and Tore Hägglund

This is a joint project between the Network for Process Intelligence (NPI) at the Mid Sweden University and Lund University. The goal of the project is to develop strategies to improve control at planned or unplanned changes in production in process control plants.

In a first phase, the drying section in a paper mill is studied. The goal is to improve control of steam pressure and moisture content at paper web breaks so that the recovery to normal operation is obtained in a shorter time. The project is performed in collaboration with the paper mill M-real, Husum.

A model of a drying cylinder, describing the relation between the steam pressure and the cylinder temperature has been developed and implemented in Matlab-Simulink. The model has been validated through experiments performed at the M-real Husum mill. In a second phase the project, this model has been used to derive optimal control

Research

of the steam pressure during web breaks. The new control strategy has been tested and is currently in use at the M-real Husum mill.

The project has resulted in a licentiate thesis by Jenny Ekvall.

Decentralized Structures for Industrial Control

Researchers: Pontus Nordfeldt and Tore Hägglund

There is an unfortunate gap between the centralized computational approaches of multi-variable control theory and the common practice to design local control loops disregarding couplings and interaction. Today it appears that both approaches has reached a point of refinement where the gap can be reduced from both sides.

This project aims to revise and improve the basic modules for decentralized control, and to develop new. By increasing the performance of the modules, the usefulness of present MIMO control functions such as MPC will increase. In this way, we will try to decrease the gap between MIMO control functions and the state of the art of process control. The ideas to be investigated in this project are relevant not only for process control but is also of interest for general classes of multi-variable systems.

In a first stage, we will develop a new module building on experiences from PID control: a 2×2 controller, i.e. a controller with two inputs and two outputs. During the year, a new PID control design method that is suitable for decoupled systems has been developed, as well as a decoupling procedure for 2×2 systems.

The project is funded by The Swedish Research Council (VR).

Biotechnology Processes

Control of Biotechnology Processes

Researchers: Lena de Maré, Stéphane Velut, and Per Hagander in cooperation with Jan Peter Axelsson, Pfizer AB, and Olle Holst, Department of Biotechnology, Lund University

Large-scale production of many enzymes and pharmaceuticals can today be made using genetically modified microorganisms. In so called bioreactors, living cells are grown to large numbers and then made to produce the desired substance. Fed-batch operation, where additional substrate is fed to the culture, is often the preferred way of production. To achieve reproducible cultivations with high cell densities and high productivity, it is important to design good strategies for the substrate-dosage control. A characteristic feature of biological processes is that many important process variables are not easily measured on-line, which complicates the design and realization of feedback strategies.

A project on substrate-dosage control of fed-batch units with genetically modified *E. coli* is performed together with Pfizer, Strängnäs. Information of how to change the substrate feed rate is obtained from standard dissolved oxygen measurements by introducing controlled process perturbations. Tuning rules are derived for the control strategy that assume a minimum of process specific information, and the system is analyzed for stability.

The feeding strategy relies on good control of the dissolved oxygen concentration. Variations in the oxygen dynamics during a fed-batch cultivation often cause tuning problems when using a controller with fixed parameters. A control approach based on gain scheduling from the stirrer speed is suggested.

The strategy is now implemented at the Departments of Biotechnology and Chemical Engineering, Lund University, at Active Biotech, in Lund and at SBL Vaccin, Stockholm, at Pfizer AB, Stockholm, Strängnäs, and Kalamazoo and tested with different *E. coli* strains and operating conditions. Good cultivation conditions and high production levels could be obtained from the first experiment. The strategy is also tested with

Research

good results in production scale and for other organisms like bakers yeast and cholera bacteria.

When the stirrer speed saturates it means that the maximal oxygen transfer capacity is reached, and the activity of cells is normally reduced by decreasing the glucose supply. An alternative is to reduce the temperature.

We have invented a combined strategy to control the dissolved oxygen by both stirrer speed and temperature using midranging. Starvation can be avoided in this way, leading to considerable advantages.

Robotics

Robotics Research and Nonlinear Systems Research

Researchers: Rolf Johansson, Klas Nilsson, and Anders Robertsson and Dr. Torgny Brogårdh, ABB Robotics

The laboratory for robotics and real-time systems is centered around an ABB Irb-6 robot and an ABB Irb-2000 robot. Hardware interfaces have been developed to create an open system suitable for control experiments. The computer hardware is VME-based with both microprocessors and signal processors integrated into an embedded system for hard real-time control. The system is connected to a network with workstations, which are used for program development and control design.

A purpose of the current project is to show how to organize open robot control systems and to verify these ideas by means of experiments. One goal is to permit efficient specification and generation of fast robot motions along a geometric path which requires coordinated adjustment of the individual joint motions. Another aspect of robot motion control is how to integrate simultaneous control of force and position according to ideas of impedance control in which stability is an important theoretical issue. A major topic in this project is to integrate aspects of control, sensor fusion and application demands using robot vision and force sensing.

Another project is on the structure and programming of control systems for industrial robots. The problem addressed is how the software architecture and the real-time structure of a robot control system should be designed to allow easy and flexible incorporation of additional sensors and new control algorithms. A software layer between a supervisory sequence control layer and the basic control level has been proposed. Case studies and prototype experiments show promising results and further implementation is going on.

The project Autofett aims towards use of force control in manufacturing operations such as robotized fettling. New sensor interfaces with modification of hardware and real-time software architectures have been developed to accommodate the use of force control algorithms based on work-space sensing.

Real-Time Control

Center for Applied Software Research (LUCAS)

Researchers: Karl-Erik Årzén, Rolf Johansson, Anders Robertsson, Anton Cervin, Dan Henriksson, Bo Lincoln, Magnus Gäfvert, Martin Andersson, Anders Blomdell, Leif Andersson, and Tomas Olsson in collaboration with Department of Computer Science and Department of Communications Systems

The Center for Applied Software Research (LUCAS) is a collaboration between the software-oriented parts of three departments at LTH:

- Computer Science,
- Communication Systems, and
- Automatic Control.

In total around 15 faculty members and 20 PhD students are involved in LUCAS. The focus of LUCAS is industrially-oriented and motivated software research. This includes research on software engineering, software technology, and software applications. Special focus is put on real-time systems, in particular embedded systems, networked systems, and control systems. The work is organized along three thematic areas:

Research

- Software Engineering Environments
- Methods in Software Engineering
- Real-Time Systems Software

The first thematic area focuses on the core areas of integrated environments (tools and methods), object-oriented languages in the tradition of Simula, Beta, and Java, and embedded systems. The research method is focused on experimental implementation and development of relevant theory. Examples of issues that are studied are configuration management, collaboration support, domain-specific languages, frameworks and patterns and Java for embedded systems. The second thematic area is focused on software development processes, methods and architectural issues for development and maintenance of complex software systems. More specifically, the research is directed towards the following key areas: software quality, verification and validation, requirements engineering, and software process architectures. The research is approached through empirical studies to understand, assess, and improve software development. The third thematic area is focused on the software aspects of real-time systems, in particular embedded system, networked systems, and control systems. Some examples of topics within the area are real-time kernels and run-time systems for embedded systems, system architectures for real-time control systems in e.g., industrial automation and robotics, integrated approaches to control design and CPU and communication bandwidth scheduling, and verification and validation of real-time systems.

The activities within LUCAS consist of research projects in collaboration with industry, center activities, and teaching activities. The projects can span the full range of LUCAS or be focused on one of the thematic areas. The aim of the center activities is to maintain the infrastructure of LUCAS and to disseminate information among the partners. The teaching activities include both graduate-level courses and continued education courses.

Industries can join LUCAS at three levels of participation. A gold member is involved in projects over the full range of LUCAS and has a long-term strategic interest in the activities of LUCAS. Silver

participants are involved in a single research project, whereas bronze members have access to the LUCAS network in terms of seminars, tutorials, courses, and workshops.

Flexible Embedded Control Systems (FLEXCON)

Researchers: Dan Henriksson, Martin Andersson, Anders Blomdell, Anton Cervin, and Karl-Erik Årzén, in collaboration with Department of Computer Science at Lund University, DAMEK at KTH, MRTC at Mälardalen University, and DRTS at University of Skövde

Control and automation systems constitute an important subclass of embedded real-time systems. Control systems have traditionally been relatively static systems. However, technology advances and market demands are rapidly changing the situation. The increased connectivity implied by Internet and mobile device technology will have a major impact on control system architectures. Products are often based on commercial-off-the-shelf (COTS) components. The rapid development of component-based technologies and languages like Java and C# increases portability and safety, and makes heterogeneous distributed control-system platforms possible. The evolution from static systems towards dynamic systems makes flexibility a key design attribute for future systems.

FLEXCON is an SSF/IT research programme between January 2003 - December 2005. The budget is 10 MSEK. The key challenge of FLEXCON is how to provide flexibility and reliability in embedded control systems implemented with COTS component-based computing and communications technology. Research will be performed on design and implementation techniques that support dynamic run-time flexibility with respect to, e.g., changes in workload and resource utilization patterns. The use of control-theoretical approaches for modeling, analysis, and design of embedded systems is a promising approach to control uncertainty and to provide flexibility, which will be investigated within FLEXCON. Other focal points are quality-of-service (QoS) issues in control systems, and testing-based verification and monitoring of flexible embedded control systems. The main application area is adaptive industrial automation systems. An industrial robotics-based demonstrator will serve as the carrier of the project results.

FLEXCON is structured in five work packages:

- **WP1: Flexibility in Real-time Embedded Control Systems using COTS Platforms, Languages and Components**

The rapid development of COTS component-based computing and communications platforms lacking stringent timing guarantees makes static system designs based on worst-case assumptions increasingly conservative. Research is needed on design and implementation techniques that allow dynamic run-time flexibility with respect to, e.g., changes in workload and resource utilization patterns. In addition it is necessary to improve the understanding of how this dynamic flexibility may be combined with more traditional real-time system approaches based on static design approaches. For example, how should event-driven execution be combined with pre-scheduled time-driven execution in embedded control systems?

- **WP123: Control-based and Quality-of-Service Approaches in Embedded Control Systems**

Using control-based approaches for modeling, analysis, and design of embedded computer and communications systems is currently receiving increased attention from the real-time systems community, as a promising foundation for controlling the uncertainty in large and complex real-time systems. Areas of growing interest include feedback architectures for adaptive real-time computing, theory for performance guarantees under uncertainty, integrated resource scheduling and feedback control, control-theoretical models of dynamic real-time systems, application of control theory for controlling timing behavior, and optimal, robust, or adaptive feedback control in real-time systems. The use of a control-based approach has the potential to increase flexibility, while preserving dependability and efficiency. For example, control techniques can be used to compensate for shortcomings and imperfections in the implementation platforms. Control approaches to resource allocation are especially interesting for distributed control systems. For example, a feedback scheduler can distribute the computing and communications resources in such a way that the global control performance, or Quality-of-Control (QoC), is maximized. QoC

is also an alternative approach to increasing dependability, e.g., through dynamic reconfiguration of resources in critical situations or for graceful degradation. The hypothesis for this work package is that flexibility in complex distributed feedback control systems can be achieved by developing a new and innovative concept for automatic negotiation of resources between control tasks based on new and appropriate measures of control quality. The overall idea is similar to the quality-of-service (QoS) concept developed for multi-media applications, but the means for estimating the achieved level of control, as well as timing requirements and resource structures are very different here. Hence, very few of the specific mechanisms and methods developed for QoS are applicable in QoC.

- **WP4: Testing-based Verification and Monitoring of Flexible Embedded Control Systems.**

Testing-based verification of flexible real-time control systems is inherently hard. Besides testing in the value domain it is also necessary to test real-time systems in the time domain. Furthermore, the flexibility offered in event-driven real-time systems require substantially more test cases for complete test coverage than a corresponding time-triggered system. From an industry perspective, research in the testing area is interesting, as there are reports stating that as much as 50 development projects can be linked to testing activities. The requirement for third-party testing of COTS components also poses a challenge. Event monitoring in such systems can support continued testing as well as performance evaluation efforts. In safety-critical control applications, the need for rigid verification is high.

- **WP: Robotics and Automation Demonstrator.**

In addition to publication of scientific results, we will confront those results with industrial aspects in an experimental setup. Apart from adding a focus to all of the workpackages, the demonstrator makes results more tangible and applicable for industry and applied research. Because of their needs for flexibility and safety in combination with needs for efficient real-time solutions and programming on several levels, robots comprise the most chal-

challenging case for flexible control. The focus here is not on robotics as such; the aim is to experimentally verify mechanisms and systems solutions for flexible embedded systems. Special emphasis will be put on dynamic deployment of control components, including testing and performance evaluation. This must be supported via host simulation, virtual models, and system access over the Internet. The physical robots and the necessary industrial experience for such a demonstrator are already available in the group, and results will be made available to other related projects. Hence, supporting this project is a golden opportunity to improve applicability of real-time systems research results.

Our department is involved in WP23 and WP5. Karl-Erik Årzén is also the program director for FLEXCON. An industrial advisory board consisting of members from ABB Robotics, ABB Automation Products, ABB Corporate Research, and Enea, supervise the progress of the project.

Reconfigurable Ubiquitous Networked Embedded Systems (RUNES)

Researchers: Martin Andersson, Dan Henriksson, Anton Cervin, and Karl-Erik Årzén

RUNES is an EU/IST FP6 integrated project on networked embedded systems with special focus on sensor/actuator networks, that started September 1, 2004. RUNES is coordinated by Ericsson and consists of 23 industrial or academic partners.

Our participation in RUNES is focused on three areas:

- control over sensor networks
- control of network resources
- simulation tools for sensor/actuator network

Within the last area we are extended the TrueTime toolbox with support for simulation of wireless networks. So far support for IEEE 802.11b (WLAN) has been added.

Design of Embedded Systems (ARTIST2)

Researchers: Martin Andersson, Dan Henriksson, Anders Robertsson, Anton Cervin, and Karl-Erik Årzén

ARTIST2 is an EU/IST FP6 network of excellence on design of embedded systems. In ARTIST2 we are a member of the cluster Control for Embedded Systems with Karl-Erik Årzén as the cluster leader. The other nodes in this cluster are KTH, Czech Technical University, the Polytechnical University of Valencia. The work within the cluster is focused on three areas:

- Control of Real-Time Computing Systems
- Real-Time Techniques in Control Systems Implementation
- Co-Design Tools for Control, Computing, and Communication.

Admission Control in Communication Networks

Researchers: Anders Robertsson and Björn Wittenmark in cooperation with Maria Kihl and Mikael Andersson, Dept. of Telecommunications, Lund Institute of Technology

In this project we consider modeling of network service control nodes and the use of nonlinear control theory for analysis and design of admission control schemes.

In the last couple of years “Communication and Control” has gained large attention and a lot of new research has focused on control of and over networks. However, the admission control problem, which is important for the utilization and the robustness of the network still remains as a rather unexplored area. Here, we believe the interaction of queuing theory and nonlinear control play a major role.

During the project a discrete-time model of server nodes has been found which aligns well with the properties of the discrete-event models from the queuing theory. The different control algorithms and the effect of different arrival and service process distributions are evaluated experimentally on an Apache web server in a laboratory network. A traffic generator is used to represent client requests. The control of the Apache server has been re-written to implement our algorithms. We

show that the control theoretic model aligns well with the experiments on the web-server. Stability analysis and controller design for both continuous and discrete-time models are considered.

Biomedical Systems

Biomedical Modeling and Control

Researchers: Rolf Johansson in cooperation with Dr Måns Magnusson (Department of Oto-Rhino-Laryngology, Lund University Hospital)

The project is directed towards assessment of normal and pathological human postural control. System identification and mathematical modeling of the dynamics in postural control are studied with special interest on adaptation, reflexive and anticipatory control. Reflexive and voluntary eye movements are studied in patients with lesions related to balance disorders. Experimental studies, with special reference to the level of alertness, are undertaken to enhance understanding, diagnosis and treatment of dizziness and vertigo. A major complication is that human postural control is characterized by multi-sensory feedback control (visual, vestibular, proprioceptive feedback) and this fact is reflected both in experiment design and analysis. Special interest is directed to the importance of cervical and vestibular afferent pathways. To this purpose, stability properties are studied by means of induced perturbations specific to each sensory feedback loop by using system identification methodology. The work is supported by the Swedish Medical Research Council and the Faculty of Medicine, Lund University

Cardiologic Analysis and Modeling

Researchers: Rolf Johansson in cooperation with Prof. S. Bertil Olsson, and Jonas Carlson, M.Sc. (Dept. Cardiology, Lund University Hospital)

This project is directed towards chronic atrial fibrillation (CAF), one of the most common cardiac arrhythmias in man and associated with increased morbidity and mortality. Previous studies in animals have shown that experimental atrial fibrillation is based on different types of intra-atrial electrical re-entry. By exploring the activation of the right atrial free wall during open-heart surgery in patients with CAF

and an underlying heart disease, we confirmed the presence of re-entry mechanisms. In addition, areas with organised activation were identified. The nature of the organised activation suggested re-entry in an anatomical structure, like the right annular bundle surrounding the tricuspid valve. In patients without signs of organised activation, multiple activation waves continuously re-enter due to functional properties of the atrial myocardium. An interesting result was that we failed to demonstrate that anisotropy in conduction velocity be a general property of the epicardial right atrial free wall of the intact human heart in patients with stable sinus rhythm as well as in patients with CAF.

Automotive Systems

Complex Embedded Automotive Control Systems (CEmACS)

Researchers: Brad Schofield, Tore Hägglund, Anders Rantzer in cooperation with DaimlerChrysler AG, University of Glasgow, The Hamilton Institute and SINTEF

The overall aim of the CEmACS project is the development of active safety systems for road vehicles. Part of the work deals with the development of controllers for rollover prevention. Rollover accidents are a common and deadly form of vehicle accident, particularly for certain vehicle classes such as Sports Utility Vehicles (SUV) and light commercial vans, where the centre of gravity can be high. In the case of commercial vehicles, both the mass and the centre of gravity vary depending on the loading conditions. This complicates the task of finding a controller to mitigate rollover.

Various systems for rollover prevention exist today in certain production vehicles, but they are rather simple. The aim of the project is to develop controllers capable of preventing rollover under all loading conditions without restricting vehicle performance unnecessarily. This requires the development of advanced methods of state estimation, parameter estimation and control design. Testing of controllers can be



Figure 5.14 DaimlerChrysler test vehicles, an A-class and S-500

done in an advanced vehicle simulation environment as well as in various test vehicles maintained by DaimlerChrysler.

Closed-loop Control of an Homogeneous Charge Compression Ignition (HCCI) Combustion Engine

Researchers: J. Bengtsson, B. Johansson(+), R. Johansson, J.O. Olsson, P. Strandh(+), P. Tunestål (+) (+)Div. Combustion Engines, Department of Heat and Power Engineering, Lund University

Homogeneous Charge Compression Ignition is a hybrid of the spark ignition and compression ignition engine concepts. As in an SI engine, a homogeneous fuel-air mixture is created in the inlet system. During the compression stroke the temperature of the mixture increases and reaches the point of autoignition, just as in a CI engine. One challenge with HCCI engines is the need for good timing control of the combustion. Auto ignition of a homogeneous mixture is very sensitive to operating condition. Even small variations of the load can change the timing from too early to too late combustion. Thus, a fast combustion timing control is necessary since it sets the performance limitation of the load control. This project deals with various approaches to feedback control of the HCCI engine for optimized fuel economy and low emissions. A 12-liter Volvo Diesel engine has been successfully converted to HCCI operation with feedback systems based upon feedback of measured cylinder pressure or ion current.

Active Control of Combustion Oscillations in Gas Turbines

Researchers: Rolf Johansson, Martin A. Kjær in cooperation with CECOST (Dr. Jens Klingmann, Prof. Torb Torisson) and Siemens

Today's strict environmental regulations are resulting in increasingly higher demands for more efficient gas turbines that provide ever lower emissions levels. This has led to a continuous development of methods and concepts for competitive and robust combustors. In LPP (Lean Premixed Prevaporised) combustion the incoming fuel is mixed prior to combustion with the air stream delivered by the compressor. The fuel is diluted by the air and hence the heat release is distributed in a bigger volume which results in lower local flame temperatures and thus less formation of NO_x. The lower temperatures in the primary combustion zone make it more difficult to sustain a stable combustion during transients and part load operation. It is therefore desirable to control the combustion process during operation actively with respect to certain characteristic stability parameters.

Acoustic waves can be described by the wave equation arising from modeling of pressure and mass flow dynamics. It is well known that the operating range of pressure and flow divides into a dynamically stable part (with fairly high mass flow) and an unstable region. Depending on the configuration of the system, different types of instability can arise, and two of such has been studied; surge and rotating stall. Using nonlinear, low order models, these types of instabilities have been generated and studied. Expanding the model with actuation (valve control of the output flow and pressure adding device) and assuming measurements of flow and pressure, controllers have been designed to stabilize the system in the low flow region. Nonlinear control methods have proved satisfactory in performance and robustness, and attempts to include adaptation to parameter variations have also been successful. A classic experiment first studied by P.L. Rijke in 1858 for demonstration and experiments of flame behavior in a resonant cavity is constructed as illustrated in the photo.

The Rijke tube is equipped with microphone and loud speaker for experiments with active control and suppression of the thermoacoustic



Figure 5.15 Photo of Rijke Tube rig

oscillations. A simplified dynamical model has been derived, describing the dynamical relationship between the loudspeaker-generated pressure and the pressure near the microphone. The model includes the coupling between the acoustic properties of the tube and the properties of the flame, and predicts oscillations with constant amplitude. Using control design and analysis methods, the oscillations are suppressed using acoustic feedback. This experiment shows the potential of active control in a combustion chamber.

Tire Models for Road Friction Estimation

Researchers: Jacob Svendenius, Magnus Gäfvert and Björn Wittenmark in cooperation with Haldex

The future trend for brake systems seems to be an exchange of pneumatics to electrical power for control and actuation. Use of electrical brakes results in a faster brake system with better controllability, but it also introduces new requirements in terms of reliability and safety thinking. The brake system is one of the most critical systems in the vehicle and new and different disturbances that can risk the safety will occur. To make use of the possibilities brought by the new type of brake actuation more knowledge about the entire vehicle system is necessary. This system, which besides the electro mechanical objects and the dynamics of the vehicle also incorporates variable factors as the driving conditions and the road foundation. Adaptive control laws and identification of uncertain parameters are necessary tools to adjust for variations. This has lead the project into modeling of the tire and its interaction with the road. The main aspect is how to estimate the adhesion limits for the tire and road surfaces. Preliminary tests have been performed on the test-track MIRA in England and in Arjeplog, Sweden, using test vehicle from Haldex, Landskrona. The tests show promising results. A major part of the work will be performed in the IVSS-project “Road Friction Estimation” with the aim to develop and implement methods for detection of the road condition during driving, using already available sensor signals. Essential for the project is validation of the reliability of the estimation, which will be implemented on test vehicle at Volvo and VTI.

Semi-Empirical Tire Model for Combined Slip

Researchers: Jacob Svendenius, Magnus Gäfvert and Björn Wittenmark in cooperation with Haldex

Accurate tire models are necessary components of models aimed at analyzing or simulating vehicle motion in real driving conditions. With new active chassis-control systems that are based on unilateral braking it is increasingly important to describe the effects of combined braking



Figure 5.16 Test truck used for tests of friction estimation at Haldex

and cornering correctly. A new easy-to-use tire-force model aimed at simulation of vehicle dynamics is developed for this purpose. The model is based on combining empirical models for pure braking and cornering with brush-model tire mechanics. The model can handle effects from camber and transient changes of the brake and cornering commands.

6. External Contacts

A healthy mix of fundamental and applied work is a cornerstone of our activities. In the applications projects the goal is to solve real control problems together with external partners. In these projects the problems are approached with an open mind without glancing at particular methods. One purpose is to learn about real problems, another is to learn about new problems that are suitable for theoretical research.

An important role for universities is to organize knowledge in such a way that the results can easily be digested by engineers in industry. There is naturally a strong symbiosis with teaching in this activity. A good mechanism is thus to introduce new research material into existing and new courses. A related form of technology transfer is to write books and monographs and to develop software.

Exchange of personnel between industry and university is another very effective vehicle for technology transfer.

Industrial Contacts

We have very good working relations with many companies and organizations. The interaction are at different levels and intensities, from visits and discussions to joint projects. Master theses and education are also important ingredients. During the year we have had major projects with

- ABB,
- Alfa-Laval,
- AssiDomän Cartonboard AB,
- Castings Technology International,
- Ericsson Mobile Platforms AB,
- Fiat Research Center,

External Contacts

Haldex,
Katholieke Universiteit Leuven,
KPS Rinas,
Krankendonk Production Systems BV,
Pfizer,
Scania CV AB,
Siemens,
Volvo.

European Collaboration

The department has successfully been involved in many applications to the 5th and 6th frame programs of the European Commission, resulting in a number of contracts involving both industry and university partners.

FP5 Projects:

- CC — Control and Computational in Hybrid Systems
- CHEM — Advanced Decision Support System for Chemical/Petrochemical Manufacturing Processes

FP6 Projects:

Networks of Excellence (NoE):

- ARTIST2 — Embedded Systems Design
- HYCON — Hybrid Control: Taming heterogeneity and complexity of networked embedded systems
- EURON-II — European Robotics Research Network

Integrated Projects (IP):

- RUNES — Reconfigurable Ubiquitous Networked Embedded Systems

Specific Targeted Research Projects (STREP):

- CEmACS — Complex Embedded Automotive Control systems

7. Looking Back – Looking Forward

Year 2004 it is 40 years since the Department of Automatic Control started at Lund Institute of Technology (LTH) and it can be interesting both to sum up some of the early history and to look forward. One part is written by an old-timer and the other of one of the younger professors at the department.

Looking back (Björn Wittenmark)

The very first years

The department gave its first course in the fourth (last) year of the Engineering Physics program in the fall of 1964. LTH started in 1961 and the first students were coming towards the end of their studies. Of the 30 students started in 1961, 12 passed the exam Automatic Control in December 19, 1964.

Acting professor in control during the first year was docent Felix Aasma from Chalmers. To his help he recruited Kalle Eklund, a fresh mechanical engineer from Chalmers. Kalle became the first teaching assistant (TA) and PhD candidate in automatic control. The first secretary of the department was Lena Jönsson starting in October 1, 1965. One of the engineering physics students taking the first course in control was Börje Häggman who started as a TA in 1965 as the first LTH graduate to work at the department.

There were four final applicants for the chair in automatic control: Felix Aasma, Anders Ljungwe, Arne Otteblad, and Karl Johan Åström. All three of the evaluators, Birger Qvarnström, Lazlo von Hámos, professors in control at Chalmers and KTH, respectively, and Lars Erik Zachrisson, docent and later professor of optimization and system

Looking back

theory at KTH, clearly placed Karl Johan Åström, then 30 years old, first in the ranking. A quote from one of the statements is, in translation:

”He [Åström] combines the intuition for technical-physical relevant problem formulations with the ability to formulate them in a mathematically adequate way and continuing the mathematical analysis until the technical consequences become obvious.”

In those days the whole faculty, with the professors in all areas, for instance, architecture, chemistry, physics, electrical measurements, should rank the applicants before the professor was appointed by the King of Sweden in an official meeting with the government. There is a quite extensive minute from LTH where many of the professors at LTH all were arguing for Karl Johan Åström, who was appointed professor in Automatic Control at LTH and started his work in Lund July 1, 1965. He started with full speed and increased it steadily.

Course development

Åström’s first task was to modernize(!) the old curriculum for the courses in control. The organization plan for creating LTH was a blueprint of KTH in Stockholm, but in a smaller scale, and the Organization Committee for LTH was headed by professor Ragnar Woxén, who also was rector of KTH. Woxén was a very executive man and came down to Lund, by train, a few days a week and solved all the administrative and practical things in starting a new school of engineering.

The first course in control should, according to the organization plan, cover, for instance: *Control technology* including the building blocks in mechanical, pneumatic, hydraulic, and electrical control systems, and complete industrial controllers. *System theory* Open and closed loop linear systems and their dynamic properties. *Application* Control of velocity, level, mass, pressure, and temperature. The advanced course in control should contain frequency analysis and the use of Laplace transform for analysis of control systems.

Karl Johan had through his work at the Inertial Guidance Group at KTH/FOA in Stockholm, IBM Research in the US, and IBM Nordic Laboratory at Lidingö come in contact with modern control theory, i.e. the state space approach, and the use of computers for control. In real-time Karl Johan developed, lectured, and wrote the lecture notes for our first courses in control, Reglerteknik AK (Automatic Control – Basic Course) and Reglerteknik FK (Automatic Control – Advanced Course). Our basic control course has essentially the same structure today as when first developed. It contains a mixture of the state space and frequency domain approaches to feedback systems. Myself I took the first course that Karl Johan taught and we were all fascinated by the dynamical, pedagogical, and enthusiastic new professor in control. Following the dress code of IBM Karl Johan gave his first lecture series in a dark blue three-piece-suit with a tie.

Our first master thesis projects were:

- Börje Häggman (1965): Control design of a sampled-data system with time-delay
- Bo Svård (1965): Investigation of the dynamical properties of an industrial process
- Bengt Pettersson (1966): Optimal control of processes with time-delays
- Björn Wittenmark (1966): Adaptive prediction
- Krister Mårtensson (1966): Numerical algorithms for solution of the minimal-time problem

Here we can already see the research areas that later became the trademark of the department.

In August 1966 after graduating in electrical engineering I was recruited as a TA. At that time we were only four people around the coffee table in the afternoons (Börje Häggman was making his military service for a year). Also from the first class of EE Ivar Gustavsson and Krister Mårtensson soon became TA's.

Starting up research and PhD programs

A formal research program was formulated by Karl Johan in 1969 (Åström, K. J.: Research program for the Department of Automatic Control, July 1969, TFRT-3011). The primary goals were already at that time:

- produce research of good international class,
- educate researchers of good international standard, and
- follow up the development and results in a wider area of control to be able to service the society with respect to choice of methods for control etc.

The research plan included identification, adaptive control, numerical methods for optimal control, applications in boiler modeling and control, and mathematical models for power systems.

At this time the first degree after the master degree was the Teknologie licentiate exam, which was approximately a three year program. The second degree was "doktorsgraden", taking an additional 3–5 years. There were at this time no formal or specific rules with respect time length and course requirements for the graduate studies in Sweden. The main emphasis was on the thesis. We who started as TA's were aiming for the licentiate degree with the intention of then starting to work in industry.

During the first years the creation of new courses, laboratory exercises, etc, took much of the time effort and the PhD courses were mainly individual reading courses. The first organized and taught PhD course in control was given in stochastic control in the spring of 1969, resulting in the book *Stochastic Control Theory* (1970) by Karl Johan Åström. The book has been translated into Russian and Japanese and will be reprinted in 2006.

At IBM Karl Johan together with Torsten Bohlin (later for many years professor in automatic control at KTH) developed the maximum likelihood method for identification and the minimum variance control based on polynomial formulations. These two methods became much of the corner stones of our later work in identification and adaptive control.

The first licentiate degrees were completed by Karl Eklund (1969), Krister Mårtensson (1970), Bengt Pettersson (1970), Ivar Gustavsson (1971), and Per Hagander (1971).

The department started to expand by the end of the 1960's and the beginning of the 1970's by accepting more PhD students. Gustaf Olsson started as Senior lecturer in 1967 and myself I became the second Senior lecturer in 1970.

In 1970 a new system for PhD studies was introduced in Sweden and PhD should be completed in four years, when the studies were done full-time. Our standard procedure has all the time been to mix PhD studies with TA duties, normally at 20% and to treat all graduate students equal irrespective of their sources for funding. After this reform almost all our graduate students aimed for the "new" PhD and the flow of PhD theses started. The first PhD theses were:

- Karl Eklund (1971): Linear drum boiler-turbine models (opponent Jens Balchen, Norwegian Institute of Technology)
- Krister Mårtensson (1972): New approaches of the numerical solution of optimal control problems (opponent Lars Erik Zachrisson, KTH)
- Torsten Söderström (1973): Uniqueness and on-line algorithms in identification of linear dynamic systems (opponent Torsten Bohlin, KTH)
- Björn Wittenmark (1973): Self-tuning regulators (opponent David Mayne, Imperial College)
- Per Hagander (1973): Operator factorization and other aspects of the analysis of linear systems (opponent Hans Blomberg, Helsinki University of Technology)

In 2004 PhD thesis number 71 was presented.

Theory and applications

Already from the beginning there was a mix of theory and application in our research. This has led to a productive cross-fertilization that has been beneficial both for the theoretical research as well as the

Looking back

applications of control. Already from the beginning Karl Johan decided that we should not have a large and costly experimental control laboratory, which was customary in those days. Instead the industry should be our laboratory. For instance, Karl Johan Åström and Kalle Eklund persuaded the regional power company Sydkraft to disconnect virtually all control loops at Öresundsverket, a large power plant in Malmö. Data was collected from many open loop experiments for different operating conditions. The data was the basis for Kalle Eklund's PhD thesis, but the data has been used ever since, for instance, to verify the simple physical boiler models published in 2000 by Karl Johan Åström and Rod Bell.

Another early industrial experiment was adaptive control of the moisture content of paper at Gruvöns Bruk in 1972–73. Here Ulf Borisson and myself made the first application of a self-tuning regulator. The application was done the same year as Karl Johan and I presented the first theoretical results on self-tuning control at the IFAC Triennial World Congress in Paris. A third example is self-tuning control of an ore-crusher in Kiruna using the computer of the department in Lund situated 1800 km away from the controlled process. The control was done using modems and the public telephone net. The sampling interval was 20 seconds. Ulf Borisson was babysitting the computer and Rolf Syding, a former master student, over-looked the process. The list of other processes used for experiments includes supertankers, steel rolling mills, digesters, waste-water plants, and a nuclear power plant.

We have been engaged in many different research projects. An attempt to illustrate this is given in Figure 7.1. The figure shows in the upper part (in red lines) the methodology (or theoretical) areas and the lower part (in green lines) shows the application areas over 40 years. We have been active in some areas over almost all years, for instance, adaptive control, computer-controlled systems, and real-time systems. Other areas have been discontinued and sometimes taken up again over and over again, for instance, applications in the pulp and paper industry. Other application areas have been associated with (PhD) projects and thus been connected to specific persons. When they left the department we have not continued in that area. One example is the supertanker application in connection with Claes Källström's thesis. When Claes left

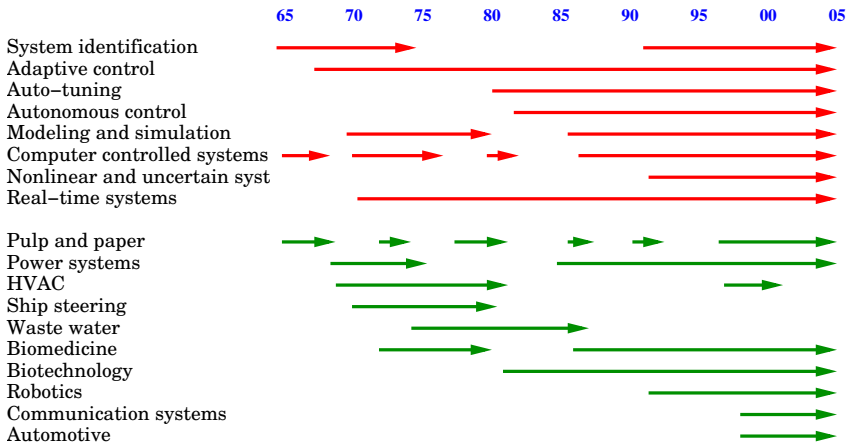

Figure 7.1 Methodology or theoretical research areas (upper part in red) and application areas (lower part in green) during 1964–2004.

to start at SSPA, the ship testing facility in Gothenburg, he could there continue the research in a much better environment than we could offer, and it was natural for the department to leave the area. Another example is the decrease of activities in identification around 1975 when Torsten Söderström left for Uppsala University and Lennart Ljung for Linköping University. They both built up their own successful research groups in identification.

Figure 7.1 shows the dynamics of the research and the mixture of methodology and applications. All the time there has been at least one application area in our research. It is also important to notice that we for long periods of time have been active in many of the research areas and thereby have been able to collect considerable insight and knowledge of the different fields.

For me the fascination with control has been that it is multidisciplinary and that our tools can be used in a large variety of areas.

Infrastructure

The department has been fortunate to attract many good students over the years, which has made it possible to develop old and new research fields. To be able to give good education and do good research it is also necessary to have a good infrastructure with devoted staff members for administration and support. We can here mention our long term members of the department Rolf Braun (starting 1969), Eva Schildt (starting 1970), and Leif Andersson (starting 1970).

The goal has all the time been to have a small, but effective administrative staff. Instead of having large semi-industrial test processes we developed a series of "desktop" processes such as the double-tank process and electrical servo systems. Some of our processes are now manufactured by Quanser and sold on an international market.

The use of computers for analysis, synthesis, and implementation has been important over all years. To start with we had to use the only computer available in Lund called SMIL. This was a copy of the van Neumann machine that was built in Lund. Later we could via modem use the computer center at Uppsala University by reading in punched cards and obtaining the printouts from a line-printer. The turn-around time for a job was four to six hours. In 1970 the department bought its first computer, a PDP-15. The main memory was expanded from the normal 8 kilowords (18-bit) to the then very extravagant 16 kilowords and we had a disk of 500 kilowords! Since this was a one-user system the computer was booked most of the hours around the clock.

A Vax system was installed in 1980 allowing several users at a time to use the computer. Now we have at least one PC or laptop on all desks.

International contacts

International contacts and participation in the international control community have been very important for the quality control of our activities from the very beginning.

One way to form a creative environment was to use funds allocated for permanent position to invite prominent scientist to Lund. In the starting years we were visited by, for instance, Mike Athans,

George Axelby, Richard Bellman, Hans Blomberg, Roger Brockett, Harald Cramér, Ruth Curtain, Pieter Eykhoff, Peter Falb, Y. C. Ho, Isaac Horowitz, Rolf Isermann, Eliahu Jury, Rudolf Kalman, Vladimir Kucera, Harold Kushner, Ioan Landau, David Mayne, Alistair MacFarlane, Sanjoy Mitter, Neil Monro, Bob Narendra, Vaclav Peterka, Howard Rosenbrock, Roger Sargent, George Saridis, Jim Schoeffler, Murray Wonham, and Lotfi Zadeh. As a young PhD student it was inspiring to meet and discuss with the international stars of control. All the seminars gave an excellent overview of the field of control.

Also some young graduate students and post docs from all over the world came and visited. Several of them have become life-long personal friends such as Graham Goodwin, David Hill, and Carlos Canudas de Wit.

Over the years the members of the department have been all over the world presenting new research and bringing home new ideas. These international contacts have been of out-most importance for the development of our research. Several of our members have also been active within our professional organizations such as IFAC, IEEE Control Systems Society, and the European Control Council.

Output data

It is difficult to summarize all activities over a period of 40 years in a couple of pages. Some hard facts are, for instance, that 26 books or edited proceedings, 483 published papers, and 872 reviewed conference papers have been produced by members of the department. Thanks to our annual reports, published since 1969, these figures are quite accurate. It is, however, also interesting to look at these publications over time. Figure 7.2 shows an accumulated index (gives good filtering of the data) of our publications. To condense the data an index has been formed by giving each published paper a weight of 1, conference papers weight 0.5, and books weight 4 and then accumulate the data over the 40 years. The weights are chosen quite arbitrarily, but reasonable. However, the main characteristic of the publication index is quite insensitive to the choice of weights. There was a steady growth the first ten years (1964–1973). Then came a 15 years period of consolidation followed by a further increase in production from around 1987. The

Looking back

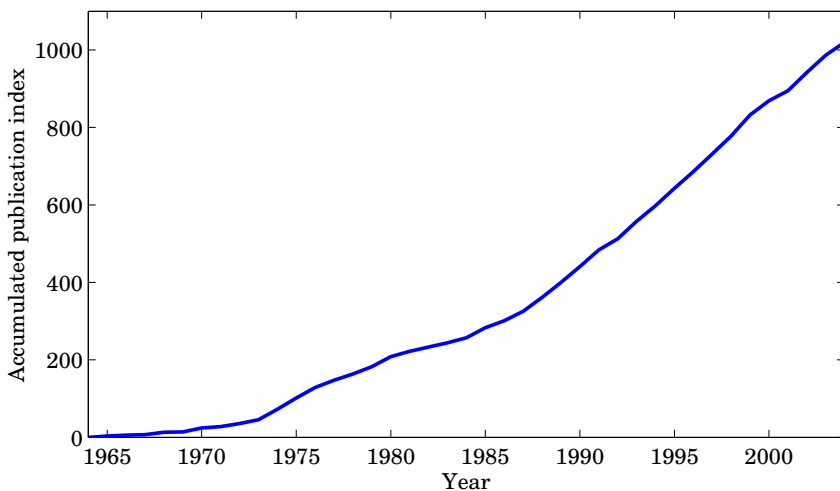

Figure 7.2 Accumulated publication index over 40 years. Books, papers, and conference papers have weight 4, 1, and 0.5, respectively.

publication index is, of course, a reflection of the number of faculty and PhD students.

Figure 7.3 shows the number of people at the department divided into academic staff, researchers (mainly fresh PhDs up to a couple of years after their exam), staff, and PhD students. There was a rapid increase during the first years and then there have been a slow but steady increase over the last 30 years.

Figure 7.4 illustrates our examination. We are using the same measure that LTH is using for the budget allocation. Each licentiate exam gets weight 0.5 and each PhD exam gets weight 1 (or 0.5 when the student earlier has an licentiate degree). The examination index has, as can be expected, a similar pattern as the publication index.

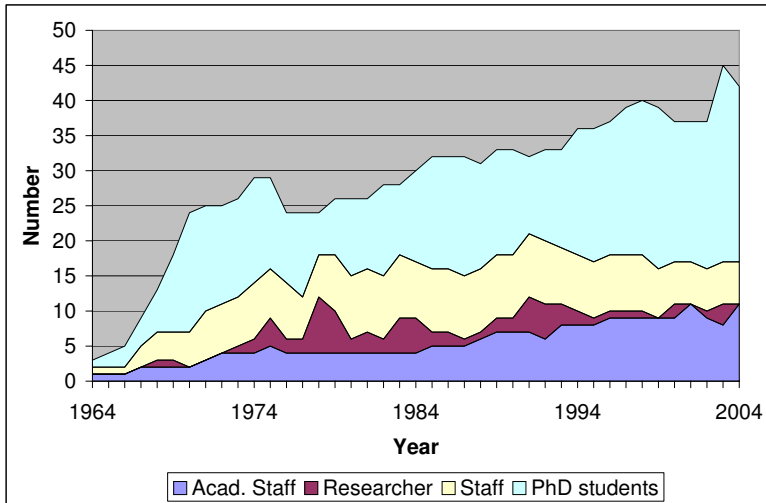

Figure 7.3 Number of members at the department divided into the categories academic staff (full, associate, and assistant professors), researchers (mainly fresh PhDs 1–3 years after their exam), staff, and PhD students.

Funding

To sum up the looking back we will also make some remarks about the development of the funding for the department. During the first 10 years the main funding was direct funds from the government to the university. External funding provided important “extra” money, which gave the department more degrees of freedom in the development. We had a project in Process Control 1969–1973 from TFR (STU) that was very important. Today it is necessary to have a larger proportion external funding. For 2004 42% of the total budget came from external sources. As a fact of curiosity the allocated funds for research and PhD education from the university don’t cover even the salaries for the professors, and are thus not contributing anything to the infrastructure.

It has been important for the department that we have succeeded in getting a number of long term grants, for instance, lately the block grant (VR ramprogram) from the Swedish Research Council and the

Looking back

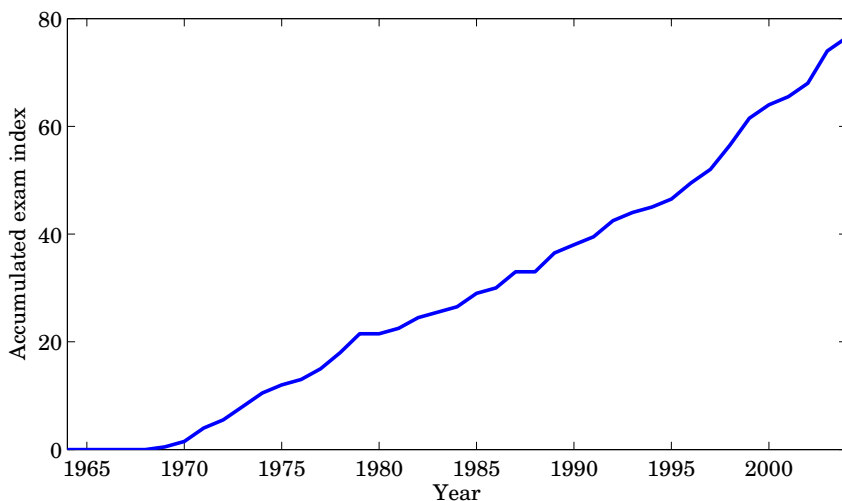

Figure 7.4 Accumulated sum of weights for licentiate (weight 0.5) and PhD (weight 1 or 0.5 when the student earlier has a licentiate degree) exams over 40 years.

Center for Chemical Process Design and Control from the Foundation for Strategic Research. These long term contracts (3–5 years) have to large extent contributed to the stability of our research. However, we are nowadays spending much more time writing proposals and evaluating, nationally as well as internationally, proposals from other researchers.

For more details about previous research activities we refer to our annual reports, which from 1995 are available on the Web.

Looking forward (Anders Rantzer)

During the academic year, 2004/05, I am having the opportunity to spend a sabbatical at California Institute of Technology. The visit is supported by the Swedish Foundation for Strategic Research in an effort for renewal of research environments in Sweden.

One of the most characteristic features of the environment at Caltech is the active interaction between different research areas, including engineering, natural sciences and even the small division of humanities and social sciences. It has been striking to observe that the same faces are often encountered in seminars on political science as in seminars on communication networks or modeling of earth quakes. This is partly related to the fact that the Caltech is fairly small in size, less than 1000 undergraduate students, but the encouragement of cross-disciplinary interaction is definitely vitalizing and can be used as a model for universities elsewhere.

The objective of this section is to present some research directions where experiences from the sabbatical year can have an impact of future activities at the Department of Automatic Control in Lund. In fact, some of the issues discussed below are relevant not only to control theory, but more generally to applied mathematics and its interaction with science and engineering. After discussing two research directions at a conceptual level, we proceed with comments on some particular application areas. Admittedly, the selection of areas is highly subjective and somewhat arbitrary.

Two promising directions for control theory

Distributed control and estimation The basic idea of distributed control is as old as money. Money defines interfaces between people that allow them to interact in a distributed manner and solve complex problems that none of them would have captured on her own. It is therefore very natural to ask to what extent the ideas and theory for economic systems can help us to understand and control also complex engineering systems, such as a paper machine, a cellular phone system or a network of power generators. The common feature of distributed control problems is that control action can be taken in many places and the available information about the system is different in each location.

Apart from economics, another source of inspiration for distributed control is nature itself. For example, the laws of mechanics can be viewed as the solution to a distributed control problem, where the global



Figure 7.5 Several challenging distributed control problem appear in space technology. One example is the idea to gather space image data from several satellites on kilometer distance from each other, but pointing in the same direction. The data is then combined to create an image of higher resolution than any existing telescope. The image quality is directly related to the coordinated control quality of the satellite movements.

minimum of the integrated Lagrangian is achieved in a distributed manner by obeying the local equations of motion. In biology, countless feedback loops are cooperating in every living organism at all levels down to the interior of each single cell. Virtually all of these control loops operate in a distributed manner, i.e. there is no centralized information processing. A challenge for control theory is to support the understanding of the mechanisms in nature, so that the ideas can be used in engineering and improve our interaction with the environment.

Given that economics and mechanics are very different subjects on the surface, it is striking to find that both fields exploit essentially the same mathematics of distributed control. A typical model in economics involves the distribution x_1, \dots, x_n of a scarce resource with $\sum_i x_i = 1$ and a number of interacting agents with utility functions $U_1(x_1), \dots, U_n(x_n)$ defining how the resource distribution affects their interests. The equilibrium price and distribution for the scarce resource is then determined by the saddle point

$$\min_p \max_{x_1 \dots x_n} \sum_i U_i(x_i) + p \left(1 - \sum_i x_i \right)$$

It is natural to study the non-equilibrium dynamics obtained by assuming that p always moves to increase the value of the expression, while x_1, \dots, x_n move to decrease it. Remarkably enough, the resulting gradient flow takes the form of a Hamiltonian system, the classical model of mechanics [Arrow *et al.*, 1958, Block *et al.*, 1992].

The study of saddle-points and equilibrium of multi-player games has been in focus of research for a long time. Particular attention has been given to the role of information, more precisely how the optimal behaviour of each player depends on the information that he has available. We will just briefly mention two observations from the literature that are bound to be important in the upcoming development of a theory for distributed control.

The first is that unlike the standard Kalman filter where all past measurements are merged into one estimate of the current state, a distributed estimator to some extent also needs to keep track of where the information came from. Otherwise there is a risk that “rumours” start spreading in an uncontrolled manner. This is the reason why news agencies and media are supposed to give citations of sources and try to get their information verified by several independent sources, but the same phenomenon appears in mathematical theory for distributed estimators [Pearl, 1988].

The second observation is that optimization problems where different control signals are based on different sets of measurements easily creates incentives for a phenomenon called “signaling” [Witsenhausen, 1968, Ho, 1980]. This means that the controllers are cooperating by sending information to each other *through* the process dynamics, by encoding their measurements into the control signals that they inject. Such encoding is not necessarily a bad idea. For example, electrical power transmission lines could very well be used also for transmission of information. However, one should be aware that whenever the incentive for signaling is present, even a linear-quadratic design objective will yield a highly nonlinear solution.

Certificates and verification Consider a computer program aimed to check stability of the differential equation $\dot{x} = Ax$. The program takes the matrix A as input and provides as output an eigenvalue with maximal real part. Apparently, the program serves its purpose, since all that remains for the stability test is to check that the real part of the output is negative. However, there is an important drawback in receiving only one eigenvalue as output: There is no simple way to verify that the output has been computed correctly.

Compare this to a program that provides a pair (U, R) , where $A = URU^{-1}$ and R is a triangular matrix. Of course, stability is still determined by the maximal real part of the eigenvalues, which appear on the diagonal of R , but now the correctness of the program output can easily be checked by verifying that the factorization is correct. Hence, we say that the pair (U, R) provides a *certificate* for verifying stability of A .

The example of matrix stability is fairly trivial compared to the situation in a complex engineering projects, such us design of an airplane or a semiconductor manufacturing machine. The point is that when many groups of people make contributions to solve a complex problem, it is highly desirable that each contribution comes with a certificate that helps verifying its correctness without doing the work again from scratch.

In everyday life, we expect to get a user's manual when we buy a car and to find a nutrition declaration when we buy food, but we haven't yet established a similar sound practice in the use of mathematical software.

Most recently, I had the opportunity to discuss topics like this with a computer scientist involved in verification of control software for a major aircraft manufacturer. The control software that runs in airplanes is supposed to implement the necessary feedback loops designed by the control engineers, but it also contains a large amount of surrounding code for the necessary redundancy, supervision, safety etc. Before flying the aircraft, ideally one would like to run a verification test for the control software together with a mathematical model of the aircraft, that would guarantee that the controller meets all

specifications. This is however far from possible. The verification tests are able to catch a large number of common software bugs, but the dynamical properties of the feedback loop are among the hardest things to check, partly because the control engineers have provided their design without proper certificates for verification.

A typical test to verify that a computer program must stop is based on construction of a positive function that decreases along every execution of the program and reaches zero only as the program stops. This is of course exactly what a control theorist would call a Lyapunov function. In effect, an ambitious software verification test aimed to check functionality of control software, needs to identify the crucial lines of code and backwards construct a Lyapunov function for the closed loop system involving a continuous time process model and include the effects of sampling and quantization (not to mention effects of multi-thread processing), to prove that all signals stay within specified bounds!

Hence, we should probably stop thinking about Lyapunov functions as theoretical tools that are mainly useful to get articles accepted in journals. View them instead as certificates, that should accompany the Bode plots for every successful design and propagate through all further modifications of the controller, such as anti-windup, sampling, A/D-, D/A-conversion and processor scheduling and eventually make it possible to produce a certificate proving validity of the final code.

Finally, the notion of certificate is intimately related to the mathematical concept of convex duality. In the last 10-20 years, a significant body of control research has been devoted to statement and solution of convex optimization problems. The main motivation for this has been computational tractability: Once a problem can be stated as a finite-dimensional convex optimization problem, there are usually effective algorithms to solve it. A maybe less well known fact is that the primal and dual variables are very well suited to serve as certificates verifying the correctness of the final solution. Moreover, whenever a convex program fails to have a feasible solution, a convex programming algorithm can be expected to provide a certificate that proves this, not just to report that it failed.

Relations to other fields

The subject of systems and control is to a large extent defined by its interaction with other fields. Historically, the subject was created when people discovered that the same basic ideas of feedback arise in a variety of engineering disciplines, such as process control, electronics and aerospace engineering. Today, the range of applications has grown and the emphasis has changed, but the main power of the subject is still its ability to unify and to support transfer of ideas between application fields.

In the subsections below, I will briefly comment on some application areas which are under active development both in Lund and at Caltech and which have natural ties to the previous discussion on distributed control and certificates.

Control with communication constraints The interplay between control and communications is a research area spanning from deep theoretical questions on fundamental limitations on control, to very practical questions on how to utilize available off-the-shelf components in an efficient manner. The problem area fits strategically in Lund, since many students with degree towards control later get communications-related jobs at Ericsson. Furthermore, LTH has well established expertise both in control and information theory and should be well prepared to address these problems, which tend to ask for the best of both. In fact, some of the most recent progress in the area has established strong connections between Bode's classical work on control limitations and Shannon's results in information channel capacity.

At Caltech, a most notable sequence of results have applied control theoretic methods for understanding of congestion dynamics in the Internet protocol and a new generation of protocols has been proposed. Moreover, a recently established cooperation between the European Commission and the Natural Science Foundation has selected the Lund/Caltech collaboration among the very first information technology projects to be funded.

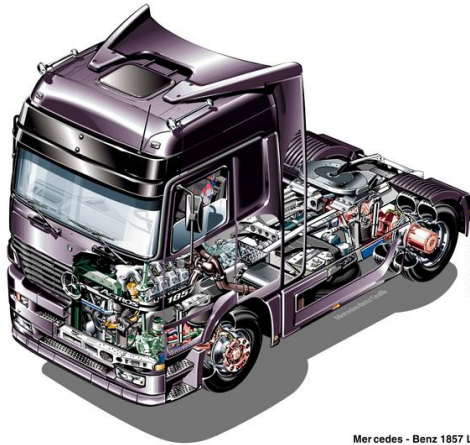

Mercedes - Benz 1857 LS

©DaimlerChrysler AG

Figure 7.6 A modern lorry involves a large number of feedback loops distributed in the vehicle. Improved control accuracy is crucial to meet future requirements on safety and environmental standards.

Control of vehicles One of the fastest growing application areas for control technology during the last few decades has been the automotive industry. This includes widely recognized features like anti-lock brakes and cruise control, but is maybe even more important as enabling technology for reduction of fuel consumption and emissions. The strong position of LTH on the global arena is reflected in continuous direct funding from Toyota Motor Company in Japan and the fact that DaimlerChrysler for the second time has initiated an EU project where our controllers are tried in their Mercedes test vehicles.

Distributed control action and communication constraints are central in control of car dynamics. For example, a locked wheel can be detected very quickly and the brake force on that wheel can immediately be adjusted. In contrast, skid prevention requires global coordination of actuators and sensors and is coupled to the wheel-lock problem in a non-trivial way.

Looking back

A vehicle of particular interest for the Lund-Caltech collaboration is the Caltech vehicle being prepared for the second race of DARPA Grand Challenge in October 2005. The goal is to have an autonomous vehicle driving along a path from Los Angeles to Las Vegas in less than 10 hours. One LTH student on the masters level worked on the project at Caltech in 2004 and four more students will be involved during 2005.

Finally, one should mention that three former PhD students from our department have founded a new company, Modelon AB, building on their thesis work to make dynamical simulation models for the automotive industry, especially for control of the climate inside the cars.

Economy and logistics We have already discussed the potential role of economic concepts in development of a theory for distributed control. However, there are also a number of very specific economic problems with natural ties to control engineering, especially in areas where economic decisions are tightly coupled to technological limitations and dynamics.

One area where such coupling is of interest is in power systems, where economic decisions on the deregulated power market are coupled to technological limitations in production and transmission of power. At our department, we have a long tradition of collaboration with the power industry. Currently we are also involved in a Caltech project where faculty from control, computer science and economics cooperate to create realistic models of how power network and resources interact with economic decision-makers, be they humans or computers.

More generally, in management of supply chains and logistics, continuous demands for time savings and reduced storage costs creates tighter integration between units and the issues of feedback become more central. The opportunities ahead are numerous and mind-boggling and previous work at the department on batch processes and graphical models fits naturally in the context.

Control in biology Finally, after attending an unusual variety of seminars during the past eight months, I am convinced that the current rapid development in life sciences offers remarkable opportunities for

any control scientist willing to spend some extra efforts communicating with colleagues from other disciplines. Actually, it is probably a mistake to view ourselves as outsiders when trying to understand the basic mechanisms of life. The problems are so complicated that no one is able to master all the techniques involved in the search for solutions. Instead the most important contributions are made by teams involving a variety of experts, including mathematicians and engineers.

The valuable interaction between biology and mathematics has been captured in an essay title by J.E. Cohen: “Mathematics Is Biology’s Next Microscope, Only Better; Biology Is Mathematics’ Next Physics, Only Better” [Cohen, 2004]. In fact, since many of the mathematical challenges in biology are intimately related to feedback control and modeling of dynamical systems, the conclusions probably apply to our subject just as well.

Bibliography

K.J. Arrow, L. Hurwicz, and H. Uzawa: Studies in linear and nonlinear programming. Stanford University Press, 1958.

Anthony M. Bloch, Roger W. Brockett, and Tudor S. Ratiu: On the geometry of saddle point algorithms. In *Proceedings of the 31st Conference on Decision and Control*, pages 1482–1487, Tucson, Arizona, 1992.

Joel E. Cohen: Mathematics is biology’s next microscope, only better; biology is mathematics’ next physics, only better. *Public Library of Science Biology*, 2(12), 2004.

Yu-Chi Ho: Team decision theory and information structures. *Proceedings of the IEEE*, 68(6):644–654, June 1980.

Judea Pearl: *Probabilistic Reasoning in Intelligent Systems: Networks of Plausible Inference*. Number ISBN:0-934613-73-7. Morgan-Kaufmann Publishers Inc., San Francisco, 1988.

H.S. Witsenhausen: A counterexample in stochastic optimum control. *SIAM Journal on Control*, 6(1):138–147, 1968.

8. Dissertations

Three PhD theses were defended by Stefan Solyom, Johan Bengtsson, and Henrik Sandberg; two Licentiate theses were completed by Tomas Olsson and Jenny Ekvall.

The abstracts are presented here in chronological order. PDF-documents of the theses are available at

<http://www.control.lth.se/publications/>.



Stefan Solyom

PhD dissertation, August 20, 2004

Opponent: Professor David Hill, City University of Hong Kong, Dept. of El Engineering, Knowloon, Hong Kong. Committee: Dir. Urban Forsell, NIRA Dynamics AB, Linköping, Sweden; Dr. Tomas McKelvey, Signal Processing Group Chalmers, Gothenburg, Sweden; Dr. Per Tunestål,

Heat and Power, LTH, Lund, Sweden; Dr. Olof Samuelsson, IEA, LTH, Lund, Sweden.

Virtually all real life systems are such that they present some kind of limitation on one or many of its variables, physical quantities. In some cases this is a direct consequence of the laws of physics. In others it is an engineering constraint. These systems are in this thesis designated as systems with limited capacity. This work is treating control related problems of a subclass of such systems, where the limitation is a critical factor.

The thesis is composed of four parts. The first part is treating the control of tire slip in a braking car. In the latest generation of brakeby-wire systems, the AntiLock Braking System (ABS) controllers have to maintain a specified tire slip for each wheel during braking. This thesis proposes a design model and a hybrid controller that regulates the tireslip. Simulation and results from drive tests are presented. In the

second part, a design method for robust PID controllers is presented, for a class of systems with limited capacity. Robustness is ensured with respect to a cone bounded static nonlinearity acting on the plant. Additional constraints on maximum sensitivity are also considered. The design procedure has been successfully applied in the synthesis of the proposed ABS controller.

The third part studies the trajectory convergence for a general class of nonlinear systems. The servo problem for piecewise linear systems is presented. Convex optimization is used to describe the behavior of system trajectories of a piecewise linear system with respect to some input signals. The obtained results are then applied for the study of antiwindup compensators.

The last part of the thesis is treating the problem of voltage stability in power systems. Voltage at the load end of a power system has to be controlled within prescribed tolerances. In case of emergencies such as sudden line failures, this task can be very challenging. The main contribution of this chapter is a method for improving the stability properties of the power system by dynamic compensation of the reference load voltage. Moreover, a complete compensation scheme is proposed where load shedding is the secondary control variable. This control scheme is shown to stabilize different power system models.

Closed-Loop Control of HCCI Engine Dynamics



Johan Bengtsson

PhD dissertation, November 26, 2004

Opponent: Prof. Christian Gerdes, Stanford University, California, USA. Committee: Dr. Peter Novak, Volvo Car Corporation, Gothenburg, Sweden; Prof. Lars Nielsen, Linköping University, Linköping, Sweden; Prof. Elbert Hendricks, Technical Univ. of Denmark, Kgs Lyngby, Denmark.

The topic of the thesis is control of Homogeneous Charge Compression Ignition (HCCI) engine dynamics. HCCI offers a potential to combine high efficiency with very low emissions. In order to fulfill the potential benefits, closed-loop control is needed.

The thesis discusses sensors, feedback signals and actuators for closed-loop control of the HCCI combustion. Closed-loop control of the HCCI combustion using ion current is demonstrated.

Models of the HCCI dynamics suitable for purposes of control design are presented. It is shown that low-order models are sufficient to describe the HCCI dynamics. Models of HCCI combustion have been determined both by system identification and by physical modeling.

Different methods for characterizing and controlling the HCCI combustion are outlined and demonstrated. In cases where the combustion phasing in a six-cylinder heavy-duty engine was controlled, either by a Variable Valve Actuation system using the inlet valve or a dual-fuel system, results are presented.

Combustion phasing is a limiting factor of the load control and emission control performance. A system where control of HCCI on a cycle-to-cycle basis is outlined and cylinder individual cycle-to-cycle control on a six-cylinder heavy duty engine is presented. Various control strategies are compared. Model-based control, such as LQG and Model Predictive Control MPC, and PID control are shown to give satisfactory controller performance. An MPC controller is proposed as a solution to the problem of load-torque control with simultaneous minimization of the fuel consumption and emissions, while satisfying the constraints on cylinder pressure.

Model Reduction for Linear Time-Varying Systems



Henrik Sandberg

PhD dissertation, December 3, 2004

Opponent: Prof. Sanjay Lall, Stanford University, Stanford, CA, USA. Committee: Prof. Paul van Dooren, Catholic Univ. of Louvain, Louvain-la-Neuve, Belgium; Dr. Lars Pernebo, ABB Automation Technologies, Malmö, Sweden; Prof. Anders Helmersson, Linköping, Sweden.

The thesis treats model reduction for linear time-varying systems. Time-varying models appear in many fields, including power systems, chemical engineering, aeronautics, and computational science. They can also be used for approximation of time-invariant nonlinear models. Model reduction is a topic that deals with simplification of complex models. This is important since it facilitates analysis and synthesis of controllers.

The thesis consists of two parts. The first part provides an introduction to the topics of time-varying systems and model reduction. Here, notation, standard results, examples, and some results from the second part of the thesis are presented.

The second part of the thesis consists of four papers. In the first paper, we study the balanced truncation method for linear time-varying state-space models. We derive error bounds for the simplified models. These bounds are generalizations of well-known time-invariant results, derived with other methods. In the second paper, we apply balanced truncation to a high-order model of a diesel exhaust catalyst. Furthermore, we discuss practical issues of balanced truncation and approximative discretization. In the third paper, we look at frequency-domain analysis of linear time-periodic impulse-response models. By decomposing the models into Taylor and Fourier series, we can analyze convergence properties of different truncated representations. In the fourth paper, we use the frequency-domain representation developed in the third paper, the harmonic transfer function, to generalize Bode's sensitivity integral. This result quantifies limitations for feedback control of linear time-periodic systems.

Feedback Control and Sensor Fusion of Vision and Force



Tomas Olsson

Licentiate dissertation, October 28, 2004

Opponent: Dr. Mikael Norrlöf, ISY, Linköping University, Linköping, Sweden.

This thesis deals with feedback control using two different sensor types, force sensors and cameras. In many tasks robotics compliance is required in order to avoid damage to the workpiece. Force and vision are the most useful sensing capabilities for a robot system operating in an unknown or uncalibrated environment. An overview of vision based estimation, control and vision/force control is given.

Two different control algorithms based on a hybrid force/vision structure are presented, using image-based and position-based visual servoing, respectively. The image-based technique is suitable in situations with simple contact geometry in uncalibrated environments, and in situations where the positioning task is naturally specified relative to some visible structure in image space. The position-based technique can handle more complex motions, which require more information about the environment. For a process with linear dynamics in task space, an edge-based visual estimation technique can be used to design an observer with linear error dynamics, which avoids the high computational complexity of the Extended Kalman Filter.

In a dynamic visual tracking system, many different choices of the parameterization of the state space exist. If the actuator- and measurement coordinate systems are rigidly attached, a dual quaternion parameterization can be used to express linear constraints on the estimated motion. This increases robustness when the intrinsic camera parameters are time-varying.

For real-time control applications in general, it is important to minimize the input-output latency, which may otherwise compromise the performance of the control system. In vision-based control systems the latency is dominated by the image processing. A method for multiple

cameras, which aims at maximizing the achieved accuracy of the measurements given a fixed computation time, is presented.

Dryer Section Control in Paper Machines During Web Breaks



Jenny Ekvall

Licentiate dissertation, November 12, 2004

Opponent: Dr. Stefan Rönnbäck, Optimization AB, Luleå, Sweden.

Web breaks in the dryer section of a paper machine cause loss of production and quality problems. After a web break, the steam pressure in the cylinders must be reduced to avoid overheating. The goal of this project is to determine optimal steam pressure trajectories during web breaks, so that the production is restarted with the same drying properties of the cylinder as before the break.

A detailed physical dynamic model of the drying cylinder has been developed. The model describes the relations between the steam valve position, the steam pressure, the cylinder temperature, and the paper temperature. The model is based on partial differential equations that describe heat conductivity for the cylinder and the paper web, and mass balances of water and dry material in the paper. The accuracy of the model has been verified through experiments made at the M-real paper mill in Hus um, Sweden. Verifications are made both during normal operation and during web breaks.

The dynamic model has been reduced in order to derive simple transfer functions between the steam pressure and the cylinder temperature, and between a logic signal that is active during web breaks and the cylinder temperature, respectively. The transfer functions obtained were used to find the optimal steam pressure trajectory during web breaks.

A new feed-forward strategy for steam pressure control during web breaks is presented. The strategy has been tested on a paper machine with good results. The strategy is built on feed-forward compensation and has been well received at the mill.

9. Honors and Awards

Anton Cervin, Bo Lincoln, Johan Eker, Karl-Erik Årzén, and **Giorgio Buttazzo** received the *Best paper Award* for their paper “The jitter margin and its application in the design of real-time control systems” at the 10th International Conference on Real-Time and Embedded Computing Systems and Applications (RTCSA’04) in Gothenburg, Sweden.

Rolf Johansson As from August 13 appointment as *Honorary Visiting Professor* at the Wuhan University of Science and Technology (WUST), Wuhan, Hubei, China.

Rolf Johansson was also given *Russell S. Springer Visiting Professor Award*, University of California, Dept. Mechanical Engineering, Berkeley, CA, USA.

Anders Ranzer was one of the eighteen Swedish scientists who received a *Senior Individual Grant from Swedish Foundation for Strategic Research (SSF)*.

Henrik Sandberg won the *Best Student-Paper Award at the 43rd IEEE Conference on Decision and Control* in the Bahamas for the paper “A Bode Sensitivity Integral for Linear Time-Periodic Systems”, co-written with **Bo Bernhardsson**.

Björn Wittenmark received the *Excellent Teaching Practice award* from Lund Institute of Technology, January 9, 2004.

10. Personnel and Visitors

Personnel

During 2004 the following persons have been employed at the department. The list shows the *status of December 2004* if nothing else is mentioned.

Professors

Karl-Erik Årzén
Karl Johan Åström (emeritus)
Bo Bernhardsson (*part time*)
Per Hagander
Tore Hägglund
Rolf Johansson
Anders Rantzer (*on leave from August*)
Björn Wittenmark

Research Associates

Anton Cervin (*from September*)
Charlotta Johnsson (*from February*)
Anders Robertsson

Researchers

Magnus Gäfvert (*until September*)
Bo Lincoln (*until January*)
Johan Bengtsson (*from December*)

Research Engineers

Leif Andersson
Anders Blomdell
Rolf Braun

Personnel and Visitors

PhD Students

Johan Åkesson

Peter Alriksson

Martin Andersson

Johan Bengtsson (*until November*)

Lena de Maré (*on leave from June*)

Isolde Dressler (*from September*)

Jenny Ekvall

Ather Gattami

Staffan Haugwitz

Dan Henriksson

Martin A. Kjær

Oskar Nilsson

Pontus Nordfeldt

Rasmus Olsson

Tomas Olsson

Mikael Petersson

Henrik Sandberg

Brad Schofield

Ola Slätteke

Stefan Solyom

Jacob Svendenius

Stéphane Velut

Andreas Wernrud

Secretaries

Britt-Marie Mårtensson

Eva Schildt

Agneta Tuszyński

Visiting Scientists

The following researchers have stayed with the department for a couple of days by the least.

Antal Bejczy *November 7–November 9, 2004*
JPL, Pasadena, CA, USA

Roemi Fernandez *September 1–December 1, 2004*
IAI-CSIC (Industrial Automation Institute, Spanish Council for Scientific Research, Madrid, Spain)

Javier Gámez García *January 11–January 19, June 7–June 30, 2004*
University of Jaén, Jaén, Spain

Alberto Herreros *March 1–September 30, 2004*
University of Valladolid, Spain

Stephen Prajna *March 1–May 31, 2004*
California Institute of Technology, Pasadena, CA, USA

Mihailo Jovanovic *October 25–October 28, 2004*
UCSB, Santa Barbara, CA, USA

Iwatani Yasushi *September 1–October 31, 2004*
Graduate School of Information Science and Engineering, Tokyo, Japan

Raffaello D'Andrea *May 8–May 15, 2004*
Cornell University, Ithaca, NY, USA

Jon Gunther *August 1 2004–June 2005*
The University of Santa Barbara, USA. Fulbright Fellow for the 2004–2005 academic year

Visiting Students

The following foreign students, mainly from the ERASMUS program, have stayed with the department and have made their master's theses.

Personnel and Visitors

Michael Attinger *from October 2004*

Technische Hochschule Stuttgart, Germany

Julien Bertholino *from July 2004*

Grenobl Inst. National Polytechnique de Granoble, France

Marco Bracci *from August 2004*

Firenze Università degli studie di Firenze, Italy

Isolde Dressler *until March 2004*

Technische Universität München, Germany

Jens Graf *from August 2004*

Technische Hochschule Darmstadt, Germany

Aguesse Rémi *March–December 2004*

Clermon Inst. Francais de Mechanique, France

Marta Virseda *until March 2004*

Universidad de Valladolid, Spain

11. Staff Activities

This is a short description of the staff (listed in alphabetic order) and their activities during the year. Publications and lectures are listed in separate sections.

Åkesson, Johan

Lic Tech, graduate student since January 2001. Johan's main research interest is in the field of decision support structures for chemical process industry, specifically systems for operator support during grade changes based on model based optimization.

Johan's research interests also include stabilization of unstable systems subject to input saturation. During 2004, Johan was a teaching assistant in the courses Real Time Systems and System Identification and co-supervised a master's thesis project; "Model based grade change support" in collaboration with Assidomän Frövi.

Alriksson, Peter

MSc graduate student since June 2003. His research interests are in estimation and optimal control of hybrid systems. In particular, he is interested in using optimal estimation for fault detection. In October and November Peter visited California Institute of Technology, Pasadena, USA. There he conducted research with Anders Rantzer who is on sabbatical at Caltech.

Andersson, Leif

MSc, Research Engineer since 1970. Leif started at the department with a responsibility for the teaching laboratory. He designed some lab equipment, notably an analog computer. In 1976 he started in earnest with digital computers, and has been responsible for the department computing facilities since then. His professional activities, apart from computer system maintenance, have ranged from computer typesetting (T_EX and L_AT_EX) via Real Time Programming to using Java as a tool for writing educational software.

Andersson, Martin

Msc, graduate student since September 2003. Martins research interests concern design and analysis of realtime control systems and networked embedded systems. He is involved in ARTES++. Martin has been a teaching assistant in the Real-Time Systems course and in the course Control forInfoCom.

Ansbjerg Kjær, Martin

Graduate student since August 2003. He is working in the field of active control of combustion instabilities together with Professor Rolf Johansson. During the last year he has been focusing on experimental research and theoretical flame modeling. His teaching activities are related to the basic automatic control course (AK) and a relatively new course designed for environmental engineering and nano-technology students.

Årzén, Karl-Erik

Professor (2000), PhD (1987): Joined the department in 1981. His research interests are real-time control, real-time systems, programming languages for control, Petri nets and Grafcet, and monitoring and diagnosis.

Project director the SSF/FLEXCON project on flexible embedded control systems. Leader for the cluster on control for embedded systems within the EU/IST FP6 network of excellence ARTIST2 on design of embedded systems. Member of the steering committee of LUCAS (Center for Applied Software Research). During the year he has primarily been involved in the EU/IST FP6 IP project RUNES (Reconfigurable Ubiquitous Networked Embedded Systems) and in the SSF/FLEXCON project.

He has been responsible for and taught the undergraduate course on Real-Time Systems and the International Project Course in Automatic Control. He has given two PhD courses: Discrete and Hybrid Control Systems and Embedded Control Systems. The latter was given as a part of the ARTES graduate school on real-time and embedded systems. He has also given a one-week course on Integrated Control and Real-Time

Scheduling at UPV in Valencia, Spain. He is partly or fully involved in the supervision of five PhD students.

Bengtsson, Johan

PhD in November 2004, Lic Tech in November 2001, joined the department in April 1999. Johan is interested in applying controls engineering to Homogeneous Charge Compression Ignition (HCCI) Engines, system identification, modeling and visual servoing. During the year he has finished his PhD, and continued work on HCCI engine control. Recent work include HCCI engine control using Variable Valve Actuation (VVA) and Model Predictive Control (MPC) as a solution to the MIMO problem of load-torque control with simultaneous minimization of the fuel consumption and emissions, while satisfying the constraints on cylinder pressure.

During the year he has been teaching assistant in Nonlinear Control and Servo Systems.

Bernhardsson, Bo

PhD 1992, Docent in 1998, and Professor in December 1999. Since 2001 Bo is on leave working at Ericsson Mobile Platforms in Lund and is working part time at our department.

Blomdell, Anders

Research Engineer since 1988. Responsible for the department network and lab computers for teaching and research. Professional interest includes man-machine interaction, real-time programming, hardware design, network communication protocols, and computer languages for control engineering.

During the previous years, Linux has been deployed on many different systems in hope of replacing the legacy STORK Real Time Kernel, which is now only used in m680x0 and PowerPC systems.

Cervin, Anton

Research assistant, PhD (2003). His research interests include real-time control systems, networked control systems, real-time scheduling

Staff Activities

theory, and computer tools for analysis and simulation of controller timing. He is involved in the EU projects RUNES (Integrated Project on Reconfigurable Ubiquitous Networked Embedded Systems) and ARTIST2 (Network of Excellence on Embedded Systems Design).

During 2004, Anton spent six months as a post-doc with Prof. Giorgio Buttazzo at the University of Pavia, Italy. During the fall he was a lecturer in the basic course in control for the information and communication engineering students.

de Maré, Lena

MSc, graduate student since August 1999. She is interested in control of biotechnical processes and is working together with Stéphane Velut and Per Hagander in the project 'Process control for cultivation of genetically modified micro-organisms' funded by Vinnova.

The research during 2004 has focused on how to control a complex feed into a bioreactor together with C. Cimander at Novozymes Biopharma AB and on temperature-limited fed-batch cultivations with *E. coli* together with O. Holst at the Biotechnology Department at LTH and C. Cimander and G. Silfversparre at Novozymes Biopharma AB and Bo Norrman and Erika Ledung at Mälardalens Högskola.

Dressler, Isolde

MSc, graduate student since September 2004. She did her undergraduate studies at Technische Universität München and Ecole Centrale Paris within the TIME double degree program. She was assistant teacher for laboratory exercises in the Automatic Control basic course.

Ekvall, Jenny

Lic Tech in November 2004, graduate student since January 2002. Jenny's main research interest is in the field of monitoring and supervision. Her present project is control and supervision at grade changes, in collaboration with Mreal, Husum. The process she studies is the drying section of a paper machine.

Jenny is employed by Mid Sweden University and she is part of the research group NPI (Network for Process Intelligence) in Örnsköldsvik, where she also has her office.

Hagander, Per

Professor, PhD (1973). Per has been with the department since 1968 and works with linear system theory and with applications in biotechnology and medicine. Per is the LTH vice rector of international affairs.

During 2004 he developed and taught the new course Control Theory.

He is leading a project with Pfizer AB, on multivariable control of genetically engineered *E. Coli*. The work is also a collaboration with the Department of Biotechnology, Lund University and Danisco AB.

A new project on the control of a special type of continuous chemical reactors was started together with Alfa Laval AB within the Center for Process Design and Control (CPDC).

Hägglund, Tore

Professor, PhD (1984). Has been at the department since 1978 except for four years when he worked for Alfa Laval Automation AB (now ABB). He is responsible for two of the basic courses in Automatic Control in the engineering program. His main research interests include process control, PID control, adaptive control, supervision, and detection.

Main research activities during the year have been design of PID controllers, decentralized control structures, and research projects in collaboration with the pulp and paper industry.

Haugwitz, Staffan

MSc, graduate student since August 2002. Staffan is working with Per Hagander on the project "Control of a Open Plate Reactor", which is funded by Alfa Laval AB and CPDC. The project is run by Alfa Laval in collaboration with several other universities and institutes in Sweden and in France. During the spring Staffan was teaching assistant in the courses Computer-Controlled Systems and Systems Engineering.

Henriksson, Dan

Lic Tech in December 2003, graduate student since December 2000. Dan's research interests concern design and analysis of real-time control systems, and he is involved in the SSF/ARTES++ project "Flexible Embedded Control Systems" (FLEXCON). During 2004 Dan has been teaching assistant in Computer-Controlled Systems and Real-Time Systems.

Johansson, Rolf

Professor, MD, PhD. Active at the department since 1979. Rolf Johansson's research interests are in system identification, robotics and non-linear systems and automotive control. He is coordinating director for Robotics Laboratory with cooperation partners from Dept Computer Science, Dept Mechanical Engineering and industrial partners. He has industrial cooperation with ABB Robotics, NFO Control AB, Volvo Powertrain, Volvo Car Corporation and Scania CV AB.

He is responsible for the two courses FRT041 System Identification and FRT050 Adaptive Control. Together with Dr. Måns Magnusson he leads research at the Vestibular Laboratory, Dept. Otorhinolaryngology, Lund University Hospital.

During 2004, Rolf visited University of California, Berkeley as Russell S. Springer Visiting Professor 2004. He also made invited research visits to University of Valladolid, Spain, Tsinghua University, Beijing, China, and he was appointed as Honorary Visiting Professor at Wuhan University of Science and Technology (WUST), Wuhan, Hubei, China.

Johnsson, Charlotta

Charlotta Johnsson returned to the department in February 2004, and holds a position as a Senior Research Associate. Her research is focused upon Batch Control Systems and Manufacturing Operations System. Charlotta got her PhD degree at the Department, in March 1999, with the thesis "A Graphical Language for Batch Control". After dissertation, Charlotta joined Orsi Automazione S.p.A., later part of Siemens A&D, and worked in Genoa, Italy for 4.5 years.

At the department, Charlotta is responsible for two undergraduate courses; Automatic Process Control for Chemical Engineering and Bio-chemical Engineering, and Systems Engineering or Environmental Engineering and Engineering Nanoscience.

Charlotta is a board member of World batch Forum (WBF) where she serves as Director of European Operations, she is the Educational Chair of ISA District 12 (Europe, Middle East, Africa and Russia). Charlotta is a voting member in the standardisation committee ISA 95, and an information member in the standardisation committees ISA 99. Charlotta is a member in SEK and serves as the Swedish expert in the international IEC and ISO working-group JWG15.

Charlotta was the Conference Co-Chair for the World Batch Forum Conference that was held in Mechelen, Belgium, October 11-13, 2004. The conference attracted around 150 people from both academia and industry (vendors and end-users).

Mårtensson, Britt-Marie

Secretary at the department since 1974. She is responsible for the department library, ordering books, handles the mail and office supplies. Assistant Webmaster. She handles the contact with printing offices for dissertations and other publications. Britt-Marie is also the department's service-person.

Nilsson, Oskar

Msc, graduate student since September 2003. Oskar is currently working on physical system modeling together with Anders Rantzer in a project funded by Toyota Motor Company. During the autumn he has been teaching assistant in the International Project Course in Automatic Control.

Nordfeldt, Pontus

MSc, graduate student since September 2003. His research interest is in automatic tuning of TITO systems. Pontus has supervised projects in the System Identification course and has been teaching assistant in the basic Automatic Control course. He has also supervised a master thesis in cooperation with TetraPak and B&R.

Olsson, Rasmus

Lic Tech, graduate student since August 1999. Rasmus area of research is batch control and diagnosis. He is part of the CPDC graduate school. His focus has been on exception handling in recipe-based batch control.

Olsson, Tomas

Lic Tech, graduate student since December 2001. His main research interests are robotic force control and vision based tracking and control. He is working with industrial force control and applications of vision-based control in the SSF/ProViking project FlexAA. During the year he has been a teaching assistant in the courses in Computer-Controlled Systems and Real-Time Systems.

Rantzer, Anders

Professor of Automatic Control since 1999. Joined the department in 1993 after a PhD at KTH 1991 and a post-doc position at IMA, University of Minnesota. He has broad interests in modeling, analysis and synthesis of control systems, with particular attention to uncertainty, optimization and distributed control.

Anders Rantzer was department chairman during the first part of 2004 and the main supervisor for seven PhD students. Two of them, Solyom and Sandberg, finished their PhD dissertations during the year. Rantzer served on several committees within the university. He served on international editorial boards and was chairman of the evaluation board in Signals and Systems for the Swedish Research Council. Using a grant from SSF he was spending the academic year 2004/05 as visiting research associate at California Institute of Technology.

Robertsson, Anders

Research Associate (May 2003), PhD (1999). His main interest is in nonlinear control and robotics. Currently he is working on sensor-data integration and force control of industrial robots in collaboration with ABB Robotics. The research has been conducted with the LUCAS project and the Robotics Lab. He has also been doing research on admission control systems in network nodes in cooperation with the

Department of Telecommunications, LTH. He has lectured the course on Nonlinear Control and Servo Systems for engineering students, the PhD-course on Nonlinear Control Synthesis and acted as advisor for several Master's Thesis projects.

During the year he has made a couple of research visit with Prof. Anton Shiriaev at the Dept. of Applied Physics and Electronics, Umeå University.

Sandberg, Henrik

PhD in December 2004. Has been at the department since January 2000. Henrik's research interests include modeling, model reduction, time-varying systems, and fundamental limitations of control systems. He has been involved in the CPDC-project "Reduction and aggregation of process models" and the VR-project "Theory for modelling, control and analysis of periodic systems". During 2004 Henrik has been a teaching assistant in the course Control Theory.

Schildt, Eva

Secretary at the Department since 1970. Eva is mainly responsible for the financial transactions of the department such as bookkeeping and reporting to our sponsors. She handles the personnel administration and takes care of the administration concerning visitors at the department.

Schofield, Brad

M.Eng (2003). Graduate student since August 2003. His research interests include adaptive control and system identification. He is involved in the Complex Embedded Automotive Control Systems (CEmACS) project which deals with active safety systems for road vehicles. Brad's work on the project involves the design of control systems for the prevention of vehicle rollover accidents. The project work is carried out in cooperation with DaimlerChrysler, as well as several other European universities. During 2004, Brad was a teaching assistant in the Adaptive Control course.

Slätteke, Ola

Lic Tech in October 2003, graduate student since January 2001. Employed by ABB Automation Technologies as an industrial PhD-student. His work is focused on modeling and control of the drying section of a paper machine within the CPDC-project. Ola also has a few years of experience of the pulp and paper industry, working at Stora Enso Nymölla AB as a control engineer.

Solyom, Stefan

MSc, graduate student since August 1999. His research interest is in nonlinear and hybrid control strategies. In particular, he is interested in piecewise linear systems. During the years he has worked on an Anti-lock Braking System within ESPRIT project H2C. There, tests have been carried out in cooperation with DaimlerChrysler. In 2002 he started working in a European project on Computation and Control (CC). He has also been teaching assistant in the course Adaptive Control.

Svendenius, Jacob

Lic Tech since November 2003 and M Sc in mechanical engineering since 1998. He worked for three years in the laboratory at Haldex Brake Products with performance testing of brakes for heavy vehicles. 2001 he started as a PhD student at the department in a project together with Haldex concerning braking control and tire modeling. Jacob is involved in the IVSS-project “Road Friction Estimation” with the aim to develop methods for detection of the road condition during driving. During 2004 he has been teaching assistant in the course on Computer Controlled Systems.

Tuszyński, Agneta

Secretary at the department since 1981. She is responsible for registration of the student’s course entries and exam results, and supervises the invoice payments from the department. She works with word processing in \LaTeX . Agneta is also responsible for Activity Report 2003 together with Per Hagander.

Velut, Stéphane

Graduate student since July 1999. Interested in control of biotechnological processes and extremum control. He is working together with Lena de Maré and Per Hagander in the Vinnova project "Process control for cultures of genetically modified microorganisms".

Wernrud, Andreas

MSc, graduate student since March 2003. His research interests include synthesis of nonlinear systems. The work has been focused on computational methods. During 2004 he was a teaching assistant in the courses Nonlinear Control, Adaptive Control and Automatic Control, basic course.

Wittenmark, Björn

Professor in Automatic Control since 1989. He joined the department in 1966 and took his PhD in 1973. His main research interests are adaptive control, sampled-data systems, and process control. He is currently working within projects in the area of process design and control and control of communication networks. Since March 1, 2003 he is appointed as Assistant vice-chancellor (Vice president) of Lund University.

External Assignments

Opponent and Member of Examination Committee

Karl-Erik Årzén: Reviewer and member of the jury of the PhD thesis by Jose-Luis Villa, Ecole des Mines de Nantes/University of Nantes, France, February 23. Member of the examination board of the PhD thesis by Jonas Mellin Dept of Computer Science, University of Skövde, June 3. Member of the examination board of the PhD thesis by Martin Sanfridson Dept of Machine Design, KTH, June 4.

Tore Hägglund: Faculty opponent on the PhD thesis by Jonas Balderud, Karlstad University, Sweden.

Staff Activities

Rolf Johansson: Y. Türkyilmaz, Modeling and Control of Towed Seismic Cables, PhD thesis, Div. Engineering Cybernetics, NTNU, Trondheim, Norway, March 19, 2004. External examiner of the doctoral thesis.

Board Member

Karl Johan Åström: Member of the Panel for the International Review of Engineering Research in the UK. Member of the panel for review of the DLR Institute of Robotics and Mechatronics, Oberpfaffenhofen.

Karl-Erik Årzén: Member of the Education Board of Computer Engineering and Communications Engineering.

Anton Cervin: Board Member and Chairman of SNART (the Swedish National Real-Time Association).

Tore Hägglund: Member of the Education Board of Engineering Physics, and the Appointment Board for FIME - physics, informatics mathematics and electrical both at Lund Institute of Technology. Expert member in legal proceedings for patent at Svea Court of Appeal, 2004–2006.

Anders Rantzer: Member of the evaluation board on Signals and Systems at the Swedish Research Council. Member of the steering committee for the International Symposium on Mathematical Theory of Networks and Systems Member of the Administrative Council for the European Union Control Association.

Björn Wittenmark: Assistant vice-chancellor (Vice president) for Lund University from March 1, 2003. Chairman of the Board of Campus Helsingborg. Board member of LUCAS. Member of the Boards of Governors of IEEE Control Systems Society. Board member of the Royal Physiographic Society, Lund. Expert member in legal proceedings for patent at Svea Court of Appeal, 2004-2006.

Book and Journal Editor

Tore Hägglund: Associate editor for Control Engineering Practice.

Rolf Johansson: Assoc. Editor Int. J. Adaptive Control and Signal Processing.

Anders Rantzer: Member of the editorial board for International Journal of Robust and Nonlinear Control.

Björn Wittenmark: Reviewer for research evaluations for the Swedish Research Council, Australian Research Council, Norwegian Research Council, and Italian National Research Council. Optimal Control Applications & Methods, Journal of Forecasting, IEE Proceedings Control Theory & Applications, and International Journal of Adaptive Control and Signal Processing.

Advisory Committees and Working Groups

Karl-Erik Årzén: Member of the IFAC Technical Committee on Chemical Process Control.

Per Hagander: Member of IFAC Technical Committee BIOMED. Member of IFAC Technical Committee Biotechnological Processes. Member of ESBES - Working group M^3C .

Tore Hägglund: IFAC Technical Committee on Adaptive and Learning Systems.

Rolf Johansson: IEEE EMBS Technical Committee (TC) for Biomedical Robotics.

Anders Rantzer: Member of the Advisory Board for Lecture Notes in Control and Information Sciences at Springer Verlag Heidelberg Member of the IEEE Control System Society Technical Committee on Nonlinear Systems and Control. Member of the IFAC Technical Committee on Nonlinear Systems. Member of the organizing committee of the Second China-Sweden Conference on Control.

Björn Wittenmark: Chairman of the committee for IFAC Control Engineering Practice Prize. Member of the Technical Committee for IFAC Adaptive Control and Learning. Member of the IEEE Control System Society International Affairs Committee. Member of the IEEE Control Systems Society George S. Axelby Outstanding Paper Award Committee.

Member of International Program Committee (IPC)

Karl-Erik Årzén: Sub-PC chair for the area Real-Time Control at RTAS 2004 (IEEE Real-Time and Embedded Technology and Application Symposium), Toronto, May 2004. Member of the IPC for RTCSA 2004 (10th International Conference on Real-Time and Embedded Computing Systems and Applications), Gothenburg, August 2004. Member of the IPC for ECRTS'05 (Euromicro Conference on Real-Time Systems), Mallorca, June 2005.

Anton Cervin: Publicity Co-Chair and Member of the IPC for the IEEE Real-Time and Embedded Technology and Applications Symposium (RTAS'04).

Per Hagander: Member of the IPC for the MCBMS'06, 6th IFAC Symposium on Modelling and Control in Biomedical Systems.

Tore Hägglund: Member of the International Program Committees for the conferences Control Systems 2004 in Quebec, Canada. Controlo 2004 - 6th Portuguese Conference on Automatic Control in Algarve, Portugal. DYCOPS 7 in Boston. 2004 IEEE Conference on Computer-Aided Control Systems Design (CACSD) in Taipei, Taiwan.

Rolf Johansson: PC Member of IFAC Symp. Advances in Automotive Control (AAC04), Salerno, Italy, April 19-23, 2004. IPC Member of IEEE 2004 Int. Conference on Robotics and Automation (ICRA2004), New Orleans, LA, USA, April 26 - May 1.

Anders Rantzer: Control Problems and Applications (CPA 05) to be held in Minsk (Belarus) on May 16-20, 2005.

12. Publications and Conference Contributions

This year 16 journal papers, 39 conference contributions, and 7 workshop papers have been published.

Journal Papers

- Bengtsson, Johan, Petter Strandh, Rolf Johansson, Per Tunestål, and Bengt Johansson: “Closed-loop combustion control of homogeneous charge compression ignition (HCCI) engine dynamics.” *International Journal of Adaptive Control and Signal Processing*, **18**, pp. 167–179, 2004.
- Cervin, Anton, and Johan Eker: “Control-scheduling codesign of real-time systems: The control server approach.” *Journal of Embedded Computing*, **1:2**, 2004.
- Fransson, P.-A., E. K. Kristinsdottir, A. Hafström, Måns Magnusson, and Rolf Johansson: “Balance control and adaptation differences between middle-aged and elderly humans.” *European Journal of Applied Physiology*, **91**, pp. 595–603, 2004.
- Gäfvert, Magnus, Karl-Erik Årzén, Lars Malcolm Pedersen, and Bo Bernhardsson: “Control of GDI engines using torque feedback exemplified by simulations.” *Control Engineering Practice*, **12:2**, pp. 165–180, February 2004.
- Gäfvert, Magnus, and Olof Lindgärde: “A 9-dof tractor-semitrailer dynamic handling model for advanced chassis control studies.” *Vehicle System Dynamics*, **41:1**, pp. 51–82, 2004.
- Hägglund, Tore, and Karl Johan Åström: “Revisiting the Ziegler-Nichols step response method for PID control.” *Journal of Process Control*, **14:6**, pp. 635–650, 2004.

Publications

- Hägglund, Tore, and Karl Johan Åström: “Revisiting the Ziegler-Nichols tuning rules for PI control - part II, the frequency response method.” *Asian Journal of Control*, **6:4**, pp. 469–482, 2004.
- Johansson, Rolf, and Anders Robertsson: “On behavioral model identification.” *Signal Processing*, **84:7**, pp. 1089–1100, 2004.
- Johansson, Rolf, Anders Robertsson, Klas Nilsson, Torgny Brogårdh, Per Cederberg, Magnus Olsson, Tomas Olsson, and Gunnar Bolmsjö: “Sensor integration in task-level programming and industrial robotic task execution control.” *Industrial Robot: An International Journal*, **31:3**, pp. 284–296, 2004.
- Johansson, Rolf, and Michel Verhaegen: “Editorial—Subspace-based identification in adaptive control and signal processing.” *International Journal of Adaptive Control and Signal Processing*, **18:9-10**, pp. 715–716, 2004.
- Kao, Chung-Yao, and Bo Lincoln: “Simple stability criteria for systems with time-varying delays.” *Automatica*, **40:8**, pp. 1429–1434, August 2004.
- Prajna, Stephen, Pablo Parrilo, and Anders Rantzer: “Nonlinear control synthesis by convex optimization.” *IEEE Transactions on Automatic Control*, **49:2**, pp. 310–314, 2004.
- Sandberg, Henrik, and Anders Rantzer: “Balanced truncation of linear time-varying systems.” *IEEE Transactions on Automatic Control*, **49:2**, pp. 217–229, February 2004.
- Sha, Lui, Tarek Abdelzaher, Karl-Erik Årzén, Anton Cervin, Theodore Baker, Alan Burns, Giorgio Buttazzo, Marco Caccamo, John Lehoczky, and Aloysius K. Mok: “Real-time scheduling theory: A historical perspective.” *Real-Time Systems*, **28:2-3**, pp. 101–155, November 2004.
- Solyom, Stefan, Anders Rantzer, and Jens Lüdemann: “Synthesis of a model-based tire slip controller.” *Vehicle System Dynamics*, **41:6**, pp. 477–511, June 2004.

Strandh, Petter, Johan Bengtsson, Rolf Johansson, Per Tunestål, and Bengt Johansson: "Cycle-to-cycle control of a dual-fuel HCCI engine." *SAE Technical paper 2004-01-0941*, 2004.

Conference Papers

Abdelzaher, Tarek, Ying Lu, Ronghua Zhang, and Dan Henriksson: "Practical application of control theory to web services." In *Proceedings of the American Control Conference*, Boston, MA, June 2004. Invited paper.

Åkesson, Johan, and Karl-Erik Årzén: "A framework for grade changes: An optimization and sequential control approach." In *Proceedings of ESCAPE-14*, Lisbon, Portugal, May 2004.

Bengtsson, Johan, Magnus Gäfvert, and Petter Strandh: "Modeling of hcci engine combustion for control analysis." In *Conference in Decision and Control (CDC 2004)*, Bahamas, 2004.

Bengtsson, Johan, Petter Strandh, Rolf Johansson, Per Tunestål, and Bengt Johansson: "Control of homogeneous charge compression ignition (HCCI) engine dynamics." In *Proceedings of American Control Conference*, pp. 4048–4053, 2004.

Bengtsson, Johan, Petter Strandh, Rolf Johansson, Per Tunestål, and Bengt Johansson: "System identification of homogenous charge compression ignition (HCCI) engine dynamics." In *IFAC Symp. Advances in Automotive Control (AAC04)*, Salerno, Italy, April 19–23, 2004, April 2004.

Cervin, Anton, Bo Lincoln, Johan Eker, Karl-Erik Årzén, and Giorgio Buttazzo: "The jitter margin and its application in the design of real-time control systems." In *Proceedings of the 10th International Conference on Real-Time and Embedded Computing Systems and Applications*, Göteborg, Sweden, August 2004. Best paper award.

de Maré, Lena, Stéphane Velut, Sebastian Briechle, Christina Wennerberg, Christian Cimander, Santosh Ramchuran, Pernilla Tunert, Gustav Silfversparre, Olle Holst, and Per Hagander: "Temperature

Publications

- limited fed-batch cultivation with a probing feeding strategy for *Escherichia coli*.” In Marie-Noelle Pons and Jan F.M. van Impe, Eds., *Computer Applications in Biotechnology 2004*, pp. 73–78. International Federation of Automatic Control, Elsevier Limited, March 2004. A proceedings volume from the 9th IFAC International Symposium, Nancy, France, 28-31 March 2004, ISBN: 0 08 044251 X.
- Ekvall, Jenny, and Tore Hägglund: “Steam pressure control during web breaks in the paper machine.” In *Control Systems 2004*, Quebec City, Canada, 2004.
- Gattami, Ather, and Richard Murray: “A frequency domain condition for stability of interconnected mimo systems.” In *Proceedings of the American Control Conference*, 2004.
- Gámez García, Javier, Anders Robertsson, Juan Gómez Ortega, and Rolf Johansson: “Sensor fusion of force and acceleration for robot force control.” In *Proceedings of 2004 IEEE/RSJ International Conference on Intelligent Robots and Systems, September 28 - October 2*, pp. 3009–3014, Sendai, Japan, September 2004.
- Henriksson, Dan, and Anton Cervin: “Multirate feedback control using the TinyRealTime kernel.” In *Proceedings of the 19th International Symposium on Computer and Information Sciences*, Antalya, Turkey, October 2004.
- Henriksson, Dan, Ying Lu, and Tarek Abdelzaher: “Improved prediction for web server delay control.” In *Proceedings of the 16th Euromicro Conference on Real-Time Systems (ECRTS 04)*, Catania, Sicily, Italy, June 2004.
- Henriksson, Dan, and Tomas Olsson: “Maximizing the use of computational resources in multi-camera feedback control.” In *Proceedings of the 10th IEEE Real-Time and Embedded Technology and Applications Symposium (RTAS04)*, Toronto, Canada, May 2004.
- Iftime, Orest, Rien Kaashoek, Henrik Sandberg, and Amol Sasane: “A Grassmanian approach to the Hankel norm approximation problem.” In *Proceedings of the 16th International Symposium on Mathematical Theory of Networks and Systems*, Leuven, Belgium, July 2004.

- Johansson, Rolf, Anders Robertsson, and Anton Shiriaev: "Observer-based strict positive real (spr) switching output feedback control." In *Proc. IEEE Conf. Decision and Control (CDC'04)*, pp. 2811–2816, December 2004.
- Johnsson, Charlotta: "Applying isa 95 - a vendor perspective." In *ISA Expo 2004*, number TP04ISA066, Houston, TX, USA, October 2004. ISA.
- Johnsson, Charlotta: "Isa 95 - how and where can it be applied?" In *ISA Expo 2004*, number TP04ISA065, Houston, TX, USA, October 2004. ISA.
- Johnsson, Charlotta, and Heike Schumacher: "Communication through b2mml - is that possible?" In *2004 WBF Annual Conference*, Lincolnshire, IL, USA, May 2004. World Batch Forum.
- Olsson, Jan-Ola, Roland Pfeiffer, Per Tunestål, Bengt Johansson, and Rolf Johansson: "Closed-loop system identification of an HCCI engine." In *IFAC Symp. Advances in Automotive Control (AAC04)*, Salerno, Italy, April 19-23, 2004, April 2004.
- Olsson, Rasmus, and Karl-Erik Årzén: "A modular batch laboratory process." In *Proc. of 7th International Symposium on Advanced Control of Chemical Processes - ADCHEM*, January 2004.
- Olsson, Rasmus, Alessandro Bindi, and Anders Robertsson: "Active damping of a flexible beam." In *Reglermöte 2004*, May 2004.
- Olsson, Tomas, Rolf Johansson, and Anders Robertsson: "Flexible force-vision control for surface following using multiple cameras." In *Proceedings of 2004 IEEE/RSJ International Conference on Intelligent Robots and Systems, IROS 2004*, pp. 798–803, Sendai, Japan, October 2004.
- Pfeiffer, Roland, Göran Haraldsson, Jan-Ola Olsson, Per Tunestål, Rolf Johansson, and Bengt Johansson: "System identification and LQG control of variable-compression HCCI engine dynamics." In *Proceedings of the 2004 IEEE International Conference on Control Applications Taipei, Taiwan, September 2-4, 2004*, pp. 1442–1447, September 2004.

Publications

- Ranaweera, Aruna, Karl Johan Åström, and Bassam Bamieh: “Lateral mean exit time of a spherical particle trapped in an optical tweezer.” In *Proc. of IEEE Conference on Decision and Control*, pp. 4891–4896, Paradise Island, Bahamas, December 2004.
- Rantzer, Anders: “ \mathcal{L}_2 gain bounded adaptive control of a first order linear system.” In *Proceedings of 16th International Symposium on Mathematical Theory of Networks and Systems (MTNS2004)*, July 2004.
- Rantzer, Anders, and Stephen Prajna: “On analysis and synthesis of safe control laws.” In *Proceedings of the 42nd Allerton Conference*, Monticello, Illinois, USA, September 2004.
- Robertsson, Anders, Anton Shiriaev, and Rolf Johansson: “Friction compensation for nonlinear systems based on the LuGre model.” In *Preprints 2004 6th IFAC-Symposium on Nonlinear Control Systems (NOLCOS 2004)*, pp. 1439–1444, Stuttgart, Germany, September 2004.
- Robertsson, Anders, Björn Wittenmark, Maria Kihl, and Mikael Andersson: “Admission control for web server systems - design and experimental evaluation.” In *Proc. of IEEE Conference on Decision and Control*, pp. 531–536, Paradise Island, Bahamas, December 2004. Invited paper.
- Robertsson, Anders, Björn Wittenmark, Maria Kihl, and Mikael Andersson: “Design and evaluation of load control in web server systems.” In *Proceeding of the 2004 American Control Conference*, pp. 1980–1985, Boston, MA, June 2004.
- Sandberg, Henrik: “A case study in model reduction of linear time-varying systems.” In *Proceedings of the 2nd IFAC Workshop on Periodic Control Systems*, pp. 249–254, Yokohama, Japan, August 2004.
- Sandberg, Henrik, and Bo Bernhardsson: “A Bode sensitivity integral for linear time-periodic systems.” In *Proceedings of the 43rd IEEE Conference on Decision and Control*, Paradise Island, Bahamas, December 2004.

- Sandberg, Henrik, Erik Möllerstedt, and Bo Bernhardsson: “Frequency-domain analysis of linear time-periodic systems.” In *Proceedings of the American Control Conference*, pp. 3357–3362, Boston, Massachusetts, June 2004.
- Shiriaev, Anton, Rolf Johansson, and Anders Robertsson: “Some comments on output feedback stabilization of the moore-greitzer compressor model.” In *Proc. IEEE Conf. Decision and Control (CDC’04)*, pp. 4465–4466, December 2004.
- Shiriaev, Anton, John Perram, Anders Robertsson, and Anders Sandberg: “Explicit formulas for general integrals of motion for a class of mechanical systems subject to virtual constraints.” In *Proc. IEEE Conf. Decision and Control (CDC’04)*, pp. 1158–1163, December 2004.
- Solyom, Stefan, Bo Lincoln, and Anders Rantzer: “A novel method for voltage stability control in power systems.” In *Proceedings of the 6th World Automation Congress, 2004*, Seville, Spain, July 2004.
- Svendenius, Jacob, and Magnus Gäfvert: “A brush-model based semi-empirical tire-model for combined slips.” In *SAE World Congress*, March 2004.
- Svendenius, Jacob, and Magnus Gäfvert: “A semi-empirical tire model for combined slips including the effects of cambering.” In *3d International Tyre Colloquium: Tyre Models For Vehicle Dynamics Analysis*, Vienna, August 2004.
- Svendenius, Jacob, and Magnus Gäfvert: “A semi-empirical tire-model for transient combined-slip forces.” In *AVEC ’04*, August 2004.
- Velut, Stéphane, and Per Hagander: “A probing control strategy: Stability and performance.” In *Proceedings of the 43rd IEEE Conference on Decision and Control, Paradise Island, Bahamas*, December 2004.

Workshop Papers

- Alriksson, Peter, Bo Bernhardsson, and Bengt Lindoff: “Automatic gain

Publications

- control in wcdma terminals.” In *Reglermöte 2004*, May 2004.
- Ekvall, Jenny: “Control of the drying section in a paper machine during a web break.” In *Reglermöte*, Gothenburg, Sweden, 2004.
- Haugwitz, Staffan, and Per Hagander: “Mid-ranging control of the cooling temperature for an open plate reactor.” In *Proceedings of Nordic Process Control Workshop*, August 2004.
- Haugwitz, Staffan, and Per Hagander: “Temperature control of a utility system for an open plate reactor.” In *Proceedings of Reglermöte*, May 2004.
- Sandberg, Henrik, and Bo Bernhardsson: “A Bode sensitivity integral for linear time-periodic systems.” In *Preprints of Reglermöte*, Göteborg, Sweden, May 2004.
- Slätteke, Ola, and Karl Johan Åström: “A grey-box model for steam pressure dynamics in the drying section of a paper machine.” In *Reglermöte 2004*, May 2004.
- Velut, Stéphane, Lena de Maré, and Per Hagander: “A modified probing feeding strategy: control aspects.”. *Reglermöte 2004*, May 2004.

Patent

- Solyom, Stefan, Bo Lincoln, and Anders Rantzer: “Power Systems.” Patent application nr. 040031-8, Svenska Patentverket.

13. Reports

During this year 3 PhD theses and 2 Licentiate theses have been published. The abstracts are presented in Chapter 7. Also 18 Master theses and 8 internal reports have been completed.

Dissertations

Bengtsson, Johan: *Closed-Loop Control of HCCI Engine Dynamics*. PhD thesis ISRN LUTFD2/TFRT--1070--SE, Department of Automatic Control, Lund Institute of Technology, Lund University, Sweden, November 2004.

Ekvall, Jenny: “Dryer section control in paper machines during web breaks.” Licentiate thesis ISRN LUTFD2/TFRT--3236--SE, Department of Automatic Control, Lund Institute of Technology, Sweden, November 2004.

Olsson, Tomas: “Feedback control and sensor fusion of vision and force.” Licentiate thesis ISRN LUTFD2/TFRT--3235--SE, Department of Automatic Control, Lund Institute of Technology, Sweden, October 2004.

Sandberg, Henrik: *Model Reduction for Linear Time-Varying Systems*. PhD thesis ISRN LUTFD2/TFRT--1071--SE, Department of Automatic Control, Lund Institute of Technology, Sweden, December 2004.

Solyom, Stefan: *Control of Systems with Limited Capacity*. PhD thesis ISRN LUTFD2/TFRT--1069--SE, Department of Automatic Control, Lund Institute of Technology, Sweden, August 2004.

Master’s Theses

Aguesse, Rémi: “Visual servoing with time delay.” Master’s thesis ISRN LUTFD2/TFRT--5734--SE, Department of Automatic Control, Lund Institute of Technology, Sweden, 2004.

Reports

- Andersson, Camilla, and Mirjam Lindberg: “Autotuning of a pid-controller.” Master’s thesis ISRN LUTFD2/TFRT-5728-SE, Department of Automatic Control, Lund Institute of Technology, Sweden, October 2004.
- Andersson, Mårten: “Optimization of an alkalinity control unit.” Master’s thesis ISRN LUTFD2/TFRT-5724-SE, Department of Automatic Control, Lund Institute of Technology, Sweden, May 2004.
- Bark, Ola: “Observerbased faultdetection in an electromechanical servo.” Master’s thesis ISRN LUTFD2/TFRT-5719-SE, Department of Automatic Control, Lund Institute of Technology, Sweden, January 2004.
- Bergkvist, Pelle, and Jörgen Lindgren: “Flexibelt linjärservo med inverterad pendel,” (A flexible linear servo with an inverted pendulum). Master’s thesis ISRN LUTFD2/TFRT-5725-SE, Department of Automatic Control, Lund Institute of Technology, Sweden, August 2004.
- Björström, Rickard: “Information-theoretic approach for path planning of a moving platform with bearings-only sensor.” Master’s thesis ISRN LUTFD2/TFRT-5727-SE, Department of Automatic Control, Lund Institute of Technology, Sweden, October 2004.
- Dressler, Isolde: “Code generation from jgrafchart to modelica.” Master’s thesis ISRN LUTFD2/TFRT-5726-SE, Department of Automatic Control, Lund Institute of Technology, Sweden, March 2004.
- Evertsson, Pontus: “Investigation of real-time operating systems: Osek/vdx and rubus.” Master’s thesis ISRN LUTFD2/TFRT-5731-SE, Department of Automatic Control, Lund Institute of Technology, Sweden, December 2004.
- Holstein, Fredrik: “Control loop performance monitor.” Master’s thesis ISRN LUTFD2/TFRT-5732-SE, Department of Automatic Control, Lund Institute of Technology, Sweden, December 2004.
- Janiec, Mikael: “Friction compensation by the use of friction observer.” Master’s thesis ISRN LUTFD2/TFRT-5729-SE, Department of Automatic Control, Lund Institute of Technology, Sweden, October 2004.

- Johansson, Björn: “Untripped suv rollover detection and prevention.” Master’s thesis ISRN LUTFD2/TFRT--5718--SE, Department of Automatic Control, Lund Institute of Technology, Sweden, February 2004.
- Kjellander, Henrik: “Arbiter and simulation for team caltech in darpa grand challenge.” Master’s thesis ISRN LUTFD2/TFRT--5730--SE, Department of Automatic Control, Lund Institute of Technology, Sweden, November 2004.
- Li, Tory: “Probing control of a fedbatch fermentation. simulation and implementation in abb industrial it.” Master’s thesis ISRN LUTFD2/TFRT--5723--SE, Department of Automatic Control, Lund Institute of Technology, Sweden, February 2004.
- Mijic, Daniel, and Calle Stödberg: “Feedback control of thermoacoustic instability using acoustic actuator.” Master’s thesis ISRN LUTFD2/TFRT--5721--SE, Department of Automatic Control, Lund Institute of Technology, Sweden, February 2004.
- Prytz Anderson, Rune, and Per Skarin: “Memory protections in a real-time operating system.” Master’s thesis ISRN LUTFD2/TFRT--5737--SE, Department of Automatic Control, Lund Institute of Technology, Sweden, November 2004.
- Svensson, Mathias: “Hard real-time control of an inverted pendulum using rtlinux/free.” Master’s thesis ISRN LUTFD2/TFRT--5722--SE, Department of Automatic Control, Lund Institute of Technology, Sweden, February 2004.
- Svensson, Ola, and Carl Windfeldt: “Controller design for a direct coupled motor.” Master’s thesis ISRN LUTFD2/TFRT--5733--SE, Department of Automatic Control, Lund Institute of Technology, Sweden, December 2004.
- Virseda, Marta: “Modeling and control of the ball and beam process.” Master’s thesis ISRN LUTFD2/TFRT--5736--SE, Department of Automatic Control, Lund Institute of Technology, Sweden, March 2004.

Other Reports

Bengtsson, Johan, and Stefan Solyom: “Abs and anti-skid on a lego car.” Technical Report LUTFD2/TFRT--7609--SE, Automatic Control, Lund Institute of Technology, Sweden, February 2004.

Henriksson, Dan, and Johan Åkesson: “Flexible implementation of model predictive control using sub-optimal solutions.” Technical Report ISRN LUTFD2/TFRT--7610--SE, Department of Automatic Control, Lund Institute of Technology, Sweden, April 2004.

Henriksson, Dan, and Anton Cervin: “TinyRealTime—an EDF kernel for the Atmel ATmega8L AVR.” Technical Report ISRN LUTFD2/TFRT--7608--SE, Department of Automatic Control, Lund Institute of Technology, February 2004.

Henriksson, Dan, and Anton Cervin: *TrueTime 1.2—Reference Manual*. Department of Automatic Control, Lund University, Sweden, October 2004.

Johnsson, Charlotta: “Whitepaper: S88 for beginners.” Technical Report, World Batch Forum, Longwood, FL, USA, June 2004.

Johnsson, Charlotta: “Whitepaper: S88 for universities.” Technical Report, World Batch Forum, Longwood, FL, USA, June 2004.

Svendenius, Jacob, and Magnus Gäfvert: “A semi-empirical tire-model including the effects of camber.” Technical Report, Department of Automatic Control, Lund Institute of Technology, Sweden, December 2004.

Tuszynski, Agneta, and Anders Robertsson: “Automatic control 2003. activity report.” Technical Report ISRN LUTFD2/TFRT--4031--SE, Department of Automatic Control, Lund Institute of Technology, Sweden, May 2004.

Reports Available

Only a limited number of copies of our reports are available for sale from the Department. Any of the listed publications may, however, be

borrowed through your library service or from the following libraries in Sweden:

- Linköpings Universitetsbibliotek, Svensktrycket, SE-581 83 Linköping
- UB, Svenska Tryckavdelningen, Box 1010, SE-221 03 Lund
- Stockholms Universitetsbibliotek, Svenska Tryckavdelningen, SE-106 91 Stockholm
- Kungliga Biblioteket, Box 5039, SE-102 41 Stockholm
- Umeå Universitetsbibliotek, Box 718, SE-901 10 Umeå
- Uppsala Universitetsbibliotek, Box 510, SE-751 20 Uppsala

Almost all our publications are available in full through our web server <http://www.control.lth.se/publications>.

The reports in the 1000- and 3000-series may be ordered from the Department, see address on page 4. Please be certain to specify both the report number and report title.

There is a copying and handling charge of between 300 and 500 SEK for each document. Invoice will be sent together with the ordered report(s).

14. Lectures by the Staff Outside the Department

Åkesson, Johan

A Framework for Grade Changes: An Optimization and Sequential Control Approach, ESCAPE-14, Lisbon, Portugal, May 19.

A Framework for Grade Changes: An Optimization and Sequential Control Approach, Carnegie Mellon University, Pittsburgh, October 29.

A Framework for Grade Changes: An Optimization and Sequential Control Approach, University of California Santa Barbara, Santa Barbara, November 3.

A Framework for Grade Changes: An Optimization and Sequential Control Approach, University of California San Diego, San Diego, November 8

Årzén, Karl-Erik

Control and Real-Time Computing: Connections and Obstacles, University of Virginia, US, March 1.

Åström, Karl Johan

Systems with Event Based Sampling, Tokyo Denku University, Tokyo, March 4.

Manual Control of Unstable Systems, Esc Sup Ingenieros, Universidad de Sevilla, Sevilla, Spain, April 18-24.

Bicycle Dynamics and Control, Esc Sup Ingenieros, Universidad de Sevilla, Spain, April 18-24.

Lectures by the Staff

Control Engineering the Hidden Technology, Symposium on Systems and Control: Challenges in the 21st Century. Delft Center for Systems and Control, Delft University of Technology, Delft, The Netherlands, June 7.

Bicycle Dynamics and Control, Department of Mechanical Engineering, Delft University of Technology, Delft, The Netherlands, June 8.

A History of Control, Workshop in celebration of John Doyle's 50th birthday, July 14.

Control and Computing, Control Design Workshop NIWeek. National Instruments, Austin, Texas, USA, August 17.

Modelica and Mechatronics?, National Instruments, Austin, Texas, USA, August 20.

Control and Computing, 50-year celebration of the Department of Engineering Cybernetics, Norwegian University of Science and Technology (NTNU), Trondheim, Norway, September 10.

Bicycle Dynamics and Control, Department of Engineering Cybernetics, Norwegian University of Science and Technology (NTNU), Trondheim, Norway, September 13.

Control the Hidden Technology, International Symposium on Intelligent and Networked Systems ISINS' 2004. Tsinghua University, Beijing, China, October 11.

Control the Hidden Technology, International Symposium on Intelligent and Networked Systems ISINS' 2004, Xian Jiao Tong University, Xian, October 11.

Control the Hidden Technology, Department of Precision Instruments, Tsinghua University, Beijing, China, October 18.

Flight Control, Department of Precision Instruments, Tsinghua University, Beijing, China, October 20.

Control the Hidden Technology, Department of Automation, Shanghai Jiao Tong University, Schanghai, China, October 21.

Cervin, Anton

Integrating control theory with real-time scheduling theory, Invited lecture. Department of Computer Engineering and Systems Science, University of Pavia, Italy, February 24.

Integrating control theory with real-time scheduling theory, Invited lecture. Real-Time Systems Laboratory, Scuola Superiore Sant'Anna, Pontedera, Italy, March 25.

Integrated control and real-time scheduling, Invited lecture. Department of Information Engineering, University of Siena, Arezzo, Italy, June 16.

The jitter margin and its application in the design of real-time control systems, 10th International Conference on Real-Time and Embedded Computing Systems and Applications (RTCSA'04), Gothenburg, Sweden.

Jitter margin and control server: handling timing variations in real-time control systems, Annual LUCAS day, Lund Institute of Technology, Lund, Sweden, October 18.

de Maré

Temperature Limited Fed-batch Cultivations with a Probing Feeding Strategy for Escherichia coli, 9th international conference on Computer Applications in Biotechnology 2004, Nancy, France, March 30.

Hagander, Per

Våra erfarenheter av kamratgranskning, Lunchseminarium vid UCLU, Lund, Sweden, March 24.

Bioprocess Control, Linköping University, April 15.

Transborder and Interregional Policy: one Scandinavian Example, the Universities of Lund and Copenhagen, Douai, France, June 7.

Hägglund, Tore

Process Control in Practice, Industrial course. Stockholm, Sweden, January 21–22.

Lectures by the Staff

Process Control in Practice, Industrial course. Stockholm, Sweden, March 2–3.

Design and Diagnosis of the Basic Feedback Loop, Tutorial lecture. 8th Advanced Process Control Applications for Industry Workshop. Vancouver, Canada , April 28.

Control Problems in the Process Industry, Plenary lecture. Reglermöte 2004, Gothenburg, Sweden, May 27.

Process Control in Practice, Industrial course. Stockholm, Sweden, November 23–24.

Haugwitz, Staffan

Temperature Control of a Utility System for an Open Plate Reactor, Reglermötet, Gothenburg, Sweden, May 26-27.

Mid-Ranging Control of the Cooling Temperature for an Open Plate Reactor, Nordic Process Control Workshop, Gothenburg, Sweden, August 19-20.

Henriksson, Dan

Maximizing the Use of Computational Resources in Multi-Camera Feedback Control, IEEE Real-Time and Embedded Technology and Applications Symposium, Toronto, Canada, May 27.

Multirate Feedback Control Using the TINYREALTIME Kernel, International Symposium on Computer and Information Sciences (ISCIS2004), Kemer-Antalya, Turkey, October 28.

Johansson, Rolf

Graduate Course ME298 Subspace-based Model Identification, at University of California, Berkeley, Dept. Mechanical Engineering. April.

System Identification, Graduate Course at Univ. Valladolid, Spain, June 7-11.

Control and Adaptation in Human Postural Dynamics, University of California, Berkeley, Dept. Mechanical Engineering, April 20.

System Integration using Robotic Work-space Sensor Data Feedback, Wuhan University of Science and Technology, Wuhan, Hubei, China, August 13.

Graduate Course on System identification Subspace Model Identification, Tsinghua University, Beijing, China, August 16-17.

Observer-Based Strict Positive Real (SPR) Systems, First Swedish-Israel Control Conference, Stockholm, September 27.

Sensor Fusion of Force and Acceleration for Robot Force Control, 2004 IEEE/RSJ International Conference on Intelligent Robots and Systems (IROS 2004), October 1.

Modeling and Identification in Medical Robotics, 26th Ann. Int. Conf. IEEE Eng. Medicine and Biology Soc. (EMBS'04), Workshop on Biomedical Robotics and Biomechatronics, San Francisco, CA, September 1. (Invited Lecture).

Control of Homogenous Charge Compression Ignition (HCCI) Combustion Engines, The 2nd Chinese-Swedish Conference on Control, Beijing, China, October 16-17. (Invited Lecture)

Observer-Based Strict Positive Real (SPR) Switching Output Feedback Control, 43rd IEEE Conf. Decision and Control (CDC'04), Atlantis, Paradise Island, Bahamas, December 16.

Johnsson, Charlotta

Communication through B2MML. Is that possible?, WBF Annual Conference 2004, Chicago, IL, USA, May 4.

Applying ISA 95 - A Vendor Perspective, ISA Expo 2004, Houston, TX, USA, October 5.

ISA 95 - How and where can it be applied?, ISA Expo 2004, Houston, TX, USA, October 5.

S95 Overview (Tutorial), WBF European Conference 2004, Belgium, October 11.

Olsson, Tomas

Flexible Force-Vision Control for Surface Following using Multiple Cameras, IEEE/RSJ International Conference on Intelligent Robots and Systems, (IROS 2004), Sendai, Japan, October 2.

Rantzer, Anders

Convexity and duality in nonlinear and hybrid control, Review meeting for the EU project CC—Control and Computation, Rome, January 26.

On Robustness to Network Delays, Workshop organized by the Department of Automatic Control at LTH for the EU project CC—Control and Computation, Lund, Sweden, May 13.

Density/cost duality applied to control and safety verification, Invited lecture, International Workshop on Dynamical Systems and Control, Technion, Haifa, Israel, June 20.

l_2 gain bounded adaptive control of a first order linear system, Invited lecture, MTNS2004, Katholieke Universiteit Leuven, Belgium, July 6.

On Analysis and Synthesis of Safe Control Laws, Invited seminar, 42nd Annual Allerton Conference on Communication, Control and Computing, September 30.

On convexity and relaxation in nonlinear and hybrid control, Invited seminar, University of California, Los Angeles, USA, October 20.

On convexity and relaxation in nonlinear and hybrid control, Invited seminar, University of California, San Diego, USA, October 25.

On convexity and relaxation in nonlinear and hybrid control, Invited seminar, California Institute of Technology, USA, November 5.

On convexity and relaxation in nonlinear and hybrid control, Invited seminar, Jet Propulsion Laboratory, Pasadena, USA, November 12.

Robertsson, Anders

Friction Compensation for a class of Nonlinear Systems Based on the LuGre Model, Swedish Control meeting, Gothenburg, Sweden, May.

Design and evaluation of load control in web server systems, American Control Conf. (ACC'04), Boston, MA, USA, June.

Friction Compensation for Nonlinear Systems Based on the LuGre Model, NOLCOS, Stuttgart, Germany, September.

On Dynamic Output Feedback Stabilization of Nonlinear Systems, 2nd Chinese-Swedish Conference on Control Chinese Academy of Science, Beijing, China, October 17.

Admission Control for Web Server Systems - Design and Experimental Evaluation, IEEE Conference on Decision and Control, Paradise Island, Bahamas, December.

Some Comments on Output Feedback Stabilization of the Moore-Greitzer Compressor Model, IEEE Conference on Decision and Control, Paradise Island, Bahamas, December.

Explicit Formulas for General Integrals of Motion for a Class of Mechanical Systems Subject to Virtual Constraints, IEEE Conference on Decision and Control, Paradise Island, Bahamas, December.

Sandberg, Henrik

A Bode Sensitivity Integral for Linear Time-Periodic Systems, Conference presentation. Reglermöte 2004, Göteborg, Sweden, May 26.

Frequency-Domain Analysis of Linear Time-Periodic Systems, Conference presentation. American Control Conference, Boston, Massachusetts, July 1.

A Case Study in Model Reduction of Linear Time-Varying Systems, Workshop presentation. IFAC Workshop on Periodic Control Systems, Yokohama, Japan, August 30.

Model Reduction for Linear Time-Varying Systems, Invited lecture. Division of Automatic Control, Department of Electrical Engineering, Linköping University, November 25.

Lectures by the Staff

A Bode Sensitivity Integral for Linear Time-Periodic Systems, Conference presentation. 43rd IEEE Conference on Decision and Control, Paradise Island, Bahamas, December 15.

Slätteke, Ola

Control of the Drying Section of a Paper Machine, Invited lecture by DEWA Consulting AB, Båstad, Sweden, March 17.

Velut, Stéphane

Probing Control of Recombinant Escherichia coli, Seminar. Pfizer, Strängnäs, Sweden, June 16.

A Probing Control Strategy: Stability and Performance, 43rd IEEE Conference on Decision and Control, Paradise Island, Bahamas, December 17.

Wittenmark, Björn

Admission control in web-server systems, Invited lecture, IEEE Hong Kong Section, City University of Hong Kong, March 24, 2004.

15. Seminars at the Department

Seminars presented in order of date. The seminars were given at the department during 2004, both by the staff and by invited lecturers. Dissertations and master's theses presentations are also included.

AC = Department of Automatic Control, Lund Institute of Technology

LTH = Lund Institute of Technology

Jan 19: **Ola Bark** (LTH), *Observerbased Faultdetection in an Electromechanical Servo*. MSc-thesis presentation.

Jan 20: **Hiroshi Ito** (Kyushu Institute of Technology, Japan), *State-dependent Scaling Approach to Stability and Performance Analysis of Nonlinear Interconnected Systems*.

Feb 2: **Mathias Svensson** (LTH), *Hard Real-time Control of an Inverted Pendulum using RTLinux/Free*. MSc-thesis presentation.

Feb 16: **Björn Johansson** (LTH), *Untripped SUV Rollover Detection and Prevention*. MSc-thesis presentation.

Feb 16: **Daniel Mijic, Calle Stödberg** (LTH), *Feedback Control of Thermoacoustic Instability Using Acoustic Actuator*. MSc-thesis presentation.

Feb 27: **Tori Li** (LTH), *Probing Control of a Fedbatch Fermentation - Simulation and Implementation in Industrial IT (ABB)*. MSc-thesis presentation.

Mar 3: **Stephen Prajna** (California Institute of Technology), *Verifying Safety with Barriers*.

Mar 30: **Isolde Dressler** (Technische Universität München), *Code Generation from JGrafchart to Modelica*. MSc-thesis presentation.

Seminars at the Department

Apr 4: **Marta Virseda Hernandez** (Universidad de Valladolid), *Modelling and Control of the Ball and Beam Process*. MSc-thesis presentation.

Apr 4: **Karl Johan Åström** (AC), *Harry Nyquist - Scientist and Engineer*.

May 3: **Nicolas Andreff**(Institut Francais de Mécanique Avancée) *Optimal Pose Selection for Vision-Based Kinematic Calibration of Parallel Mechanisms*.

May 5: **Yasushi Iwatani** (Tokyo Institute of Technology), *Stability Tests Based on Eigenvalue Loci for Bimodal Piecewise Linear Systems*.

May 7: **Mårten Andersson** LTH), *Optimization of an Alkalinity Control Unit*. MSc-thesis presentation.

May 7: **Rolf Johansson** (AC), *Visiting Professor at University of California, Berkeley*.

July 6: **Julien Bertholino** (Institut National Polytechnique de Grenoble), *Embedded JGrafchart for Task Coordination in Robot Applications*. MSc-thesis presentation.

Aug 13: **Pelle Bergkvist, Jörgen Lindgren** (LTH), *Flexibelt linjärservo med inverterad pendel*. MSc-thesis presentation.

Aug 19: **David Hill** (City University of Hong Kong), *Pattern-based Switching and Tuning Control for Complex Systems*.

Aug 20: **Stefan Solyom** (AC), *Control of Systems with Limited Capacity*. Doctoral dissertation defence.

Sep 21: **Rickard Björström** (LTH), *Information-theoretic Approach for Path Planning of a Moving Platform with Bearings-only Sensor*. MSc-thesis presentation.

Sep 23: **Roemi Fernandez Saavedra** (Instituto de Automatica Industrial, Spain), *Non Classically Actuated Robotic Systems*.

Sep 30: **Leonid Mirkin**(Technion-Israel Institut of Technology), *Why the H -inf Fixed-Lag Smoothing Performance Saturates*.

Oct 7: **Mikael Janiec** (LTH), *Friction Compensation by the use of a Friction Observer*. MSc-thesis presentation.

Oct 13: **Camilla Andersson, Mirjam Lindberg** (LTH), *Autotuning of a PID Controller*. MSc-thesis presentation.

Oct 27: **Mihailo Jovanovic** (University of California, Santa Barbara), *Input-Output Analysis of the Linearized Navier-Stokes Equations*.

Oct 28: **Tomas Olsson** (AC), *Feedback Control and Sensor Fusion of Vision and Force*. Doctoral dissertation defence.

Oct 28: **Mikael Norrlöf** (LiTH), *Some Fundamental Limitations in Causal and CITE Iterative Learning Control*.

Nov 8: **Antal Bejczy** (JPL, Caltech), *Space Robotics - Topics, Results and Challenges*.

Nov 12: **Jenny Ekvall** (AC and Mitthögskolan), *Dryer Section Control in Paper Machines during Web Breaks*. Lic Tech dissertation seminar.

Nov 15: **Pontus Evertsson** (LTH), *Investigation of RTOS:OSEK/ VDX and Rubus*. MSc-thesis presentation.

Nov 18: **Henrik Kjellander** (LTH), *Arbiter and Simulation for Team Caltech in DARPA Grand Challenge*. MSc-thesis presentation.

Nov 25: **Chris Gerdes** (Stanford University), *Control of Homogeneous Charge Compression Ignition Engines Using Variable Valve Actuation*.

Nov 26: **Johan Bengtsson** (AC), *Closed-loop Control of HCCI Engine Dynamics*. Doctoral dissertation defence.

Nov 26: **Rune Prytz Andersson, Per Skarin** (LTH), *Memory protection in a real-time operating system*. MSc-thesis presentation.

Dec 1: **Sanjay Lall** (Stanford University), *Semi-definite Programming Relaxations and Algebraic Optimization with Engineering Applications, Part 1*.

Dec 2: **Sanjay Lall** (Stanford University), *Semi-definite Programming Relaxations and Algebraic Optimization with Engineering Applications, Part 2*.

Seminars at the Department

Dec 3: **Henrik Sandberg** (AC), *Model Reduction for Linear Time-Varying Systems*. Doctoral dissertation defence.

Dec 9: **National Instruments** *Overview of LabVIEW*.

Dec 10: **Claudio De Persis** (University of Rome), *A Few Results on Nonlinear Control under Data Rate Constraints*.

Dec 14: **Fredrik Holstein** (LTH), *Control Loop Performance Monitor*. MSc-thesis presentation.

Dec 15: **Carl Winfeldt, Ola Svensson** (LTH), *Controller Design for a Direct Coupled, Synchronous Motor*. MSc-thesis presentation.

Dec 20: **Michael Kwapisz** (LTH), *Controlling an Inverted Pendulum*. MSc-thesis presentation.