



LUND UNIVERSITY

Freeze-thaw resistance of concrete : destruction mechanisms, concrete technology, test methods, quality control : a contribution to the BRITE/EURAM project BREU-CT92-0591 "The Residual Service Life of Concrete Structures"

Fagerlund, Göran

1995

[Link to publication](#)

Citation for published version (APA):

Fagerlund, G. (1995). *Freeze-thaw resistance of concrete : destruction mechanisms, concrete technology, test methods, quality control : a contribution to the BRITE/EURAM project BREU-CT92-0591 "The Residual Service Life of Concrete Structures"*. (Report TVBM; Vol. 3060). Division of Building Materials, LTH, Lund University.

Total number of authors:

1

General rights

Unless other specific re-use rights are stated the following general rights apply:

Copyright and moral rights for the publications made accessible in the public portal are retained by the authors and/or other copyright owners and it is a condition of accessing publications that users recognise and abide by the legal requirements associated with these rights.

- Users may download and print one copy of any publication from the public portal for the purpose of private study or research.
- You may not further distribute the material or use it for any profit-making activity or commercial gain
- You may freely distribute the URL identifying the publication in the public portal

Read more about Creative commons licenses: <https://creativecommons.org/licenses/>

Take down policy

If you believe that this document breaches copyright please contact us providing details, and we will remove access to the work immediately and investigate your claim.

LUND UNIVERSITY

PO Box 117
221 00 Lund
+46 46-222 00 00



LUNDS TEKNISKA HÖGSKOLA
Byggnadsmaterial

UNIVERSITY OF LUND
LUND INSTITUTE OF TECHNOLOGY
Division of Building Materials

FREEZE-THAW RESISTANCE OF CONCRETE

Destruction mechanisms. Concrete technology.
Test methods. Quality control

Göran Fagerlund

CODEN: LUTVDG/(TVBM-3060)/1-73/1995

ISSN 0348-7911

FREEZE-THAW RESISTANCE OF CONCRETE

Destruction mechanisms. Concrete technology.
Test methods. Quality control

**A contribution to the BRITE/EURAM project BREU-CT92-0591
"The Residual Service Life of Concrete Structures"**

Göran Fagerlund

Report TVBM-3060

Lund, November 1995



Contents	Page
Preface	1
1. Introduction	2
2. Frost damage and its effects	2
2.1 Types of frost damage	2
2.2 Effects of frost damage	3
2.2.1 Internal frost damage	3
2.2.2 Surface scaling	6
3: Freezing of water in the concrete	10
3.1 Water in the cement paste	10
3.2 Water in the aggregate	11
3.3 Water in airpores	13
3.4 Water in continuous airpores	14
3.5 Water in deep cracks	14
3.6 Water in interfaces	15
4. Effect of the freezing temperature; The destruction mechanisms	16
4.1 Effect of the lowest temperature	15
4.2 Effect of the rate of freezing	18
4.2.1 Moisture isolated freeze/thaw	18
4.2.2 Unisolated freeze/thaw	19
5. Effect of salt solution	21
5.1 Internal damage in moisture isolated freeze/thaw	21
5.2 Salt scaling	24
6. The critical spacing factor	27
6.1 The critical Powers spacing factor	27
6.2 The critical true spacing factor	32
7. The required air content; theoretically	35
7.1 Based on the critical Powers spacing factor	35
7.2 Based on the critical true spacing factor	36
8. The air content in practice	39
8.1 Principles	39
8.2 Air in fresh concrete versus air in hardened concrete	42
9. Effect of different concrete technology factors	43
9.1 Portland cement	43
9.2 Mineral admixtures	46
9.3 Air-entraining agents	52
9.4 Water reducing agents and superplastizicers	53
9.5 Aggregate	53
9.6 Mixing	54
9.7 Curing	54

10 Test methods for frost and salt scaling resistance	54
10.1 General	54
10.2 Salt scaling	55
10.3 Multi-cycle unisolated freeze/thaw	59
10.4 Critical dilation	64
10.4.1 Test principles	64
10.4.2 Control of coarse aggregate	62
10.5 The critical degree of saturation method	62
11 Recommendations for a quality control system	64
11.1 General principles	64
11.2 Pre-tests	65
11.2.1 Pre-tests of the salt scaling resistance	65
11.2.2 Pre-test of the "internal" frost resistance by a dilation test	67
11.3 Production tests	68
11.3.1 The air content of the fresh mix	68
11.3.2 Salt scaling tests on manufactured specimens	68
11.3.3 Air content of the hardened concrete	68
11.3.4 Salt scaling tests of drilled-out specimens	69
12 Important conclusions	69
References	71

Preface

In this report a rather comprehensive analysis is made of the frost and salt scaling resistance of concrete. Both theoretical and empirical information are provided. On that basis recommendations are given for the concrete quality that is required for a certain service life and also recommendations for the testing of concrete with regard to its potential frost resistance.

The report is produced within the project BRITE/EURAM BREU-CT92-0591 "The Residual Service Life of Concrete Structures". Its official designation is, "Deliverable 30.4 part 1.

Six partners are involved in the project:

- 1: British Cement Association (The Coordinator)
- 2: Instituto Eduardo Torroja, Spain
- 3: Geocisa, Spain
- 4: The Swedish Cement and Concrete Research Institute, Sweden
- 5: Cementa AB, Sweden
- 6: Division of Building Materials, Lund University, Sweden

Three deterioration mechanisms are treated in the project:

- 1: Corrosion of the reinforcement
- 2: Freeze-thaw effects
- 3: Alkali-silica reaction

This report refers to Task 4, "Assessment of deterioration rates" but also to Task 2, "Assessment of current state of the material in the member".

Lund, November 1995

Göran Fagerlund

Other official deliverables within the BRITE-project, dealing with freeze-thaw are:

Deliverable 12.1	<i>Calculation of the moisture-time fields in concrete</i>
Deliverable 12.5	<i>The long-time water absorption in the air-pore structure of concrete</i>
Deliverable 18.6	<i>The critical spacing factor</i>
Deliverable 24.1	<i>Influence of environmental factors on the frost resistance of concrete</i>
Deliverable 28.1	<i>Effect of frost damage on the bond between reinforcement and concrete</i>
Deliverable 30.1	<i>Assessment of the current state of the structure</i>
Deliverable 30.4, Part 2	<i>Interrelations between the service life and the air content of concrete exposed to freeze-thaw</i>
Deliverable 30.4, Part 3	<i>Estimation of the future deterioration caused by frost action</i>

1. Introduction

High moisture contents within the concrete and a saline outer environment might cause severe frost destruction of the interior of concrete, and of the concrete cover. Frost damage is of a character that makes it almost impossible to repair; especially if the cohesion and the bond to the reinforcement is lost. Therefore, all types of deep frost damage (damage to centimeter depths at the surface, or internal damage) must be avoided during the entire required service life of the structure. The concrete must be of an exceptionally high quality to resist a marine environment in the Nordic climate, and the heavy use of de-icing agents, that can be expected on bridges and other concrete structures with car traffic. Concretes, that are only exposed to pure water in combination with frost, might be of somewhat lower quality. Structures in this, a bit milder environment must, however, also be made of concrete with low water/cement ratio and some air-entrainment.

In the report, a rather comprehensive review is made of the phenomena salt scaling and internal frost attack. Relations between the concrete composition, and the frost resistance, are presented and discussed. Methods for development of frost resistant concretes, and for strict control of the frost resistance of more advanced concrete structures are suggested. Parts of these control procedures are also suitable for normal structures.

2. Frost damage and its effects

2.1 Types of frost damage

There are two different types of frost damage. They are visualized in Fig 1:

1. *Internal damage* caused by the freezing of water contained in:

- capillary pores within the cement paste
- pores in fine-porous and saturated coarse aggregate grains
- air-pores
- deep cracks
- interface zones between the aggregate and the cement paste

2. *Surface scaling* caused by freezing of the concrete surface when it stays in contact with saline solutions of weak concentration.

Freezing of moist concrete in pure water does seldom lead to surface scaling, but more often to internal damage.

Freezing of concrete exposed to salt solution at the surface does seldom lead to internal damage, but often to surface scaling.

The fact, that there are two types of damage, implies that two types of test methods are needed:

- 1: A freeze/thaw test with pure water, revealing the risk of internal frost damage.
- 2: A salt scaling test, revealing the risk of surface scaling.

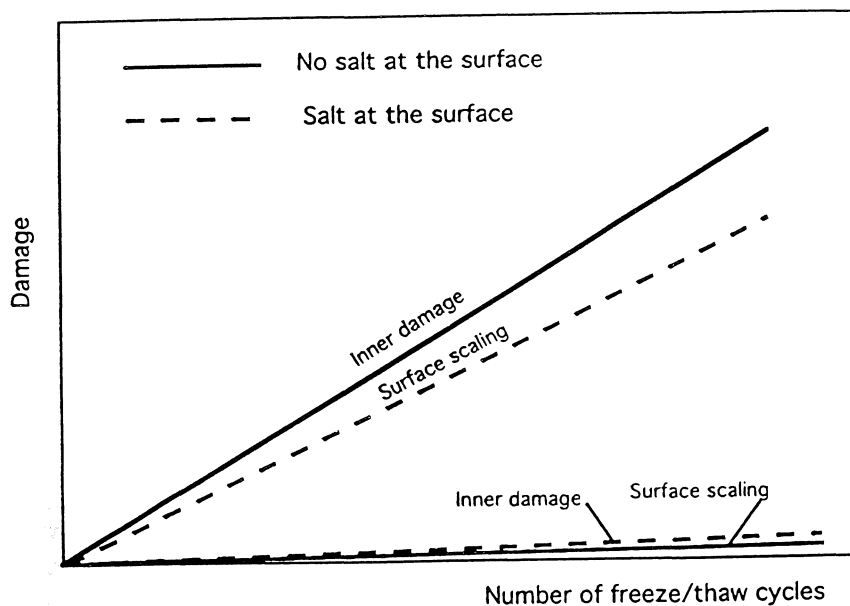

Fig 1: The two main types of frost damage; principles.

2.2 Effects of frost damage

2.2.1 Internal frost damage

Internal frost attack leads to loss of cohesion of the concrete. This means, that the concrete strength is reduced, and the bond between the reinforcement and the concrete is even more reduced.

An example of the relation between the loss in E-modulus, or the loss in split tensile strength, and the loss in bond is seen in Fig 2a and 2b. The specimens are cylinders with the diameter 200 mm and the length 200 mm containing a central ribbed bar of diameter 25 mm with the bond length 100 mm. The specimens were water saturated by vacuum, using different residual pressures, so that different degrees of saturation were obtained. Then, they were wrapped in plastic foil as a protection against water loss, or uptake. They were exposed to 7 freeze/thaw cycles (24 h freezing+24 h thawing) during a period of two weeks, so that more or less severe frost damage occurred. The degree of damage was measured by the loss in the speed of sound, and by the loss in the split tensile strength.

The loss in E-modulus varies from about 20 % to about 80 %. The corresponding loss in bond strength is about 35 % and 60 %. Thus, the bond strength is more rapidly affected by frost than the E-modulus; also a rather small frost damage, judged by the loss in E-modulus, causes a large loss in bond.

The relation between the loss in split tensile strength, and the the loss in bond strength, measured on the same specimens as those in Fig 2a, is shown in Fig 2b. The split tensile strength is more affected by frost than the E-modulus. There seems to be a fairly linear relationship between loss in bond and the loss in tensile strength.

Fig 2 shows clearly, that a severe reduction in the performance of the concrete occurs when the concrete is frost damaged. Considerable frost damage occurs already after one single freeze/thaw cycle, when the concrete is more than critically saturated; Fagerlund [1975]. An example of the effect of one and two freeze/thaw cycles on the residual length expansion of a certain concrete, with different degrees of saturation, is shown in Fig 3. The critical degree of saturation is within the range 0,85-0,88. Even a small transgression of the critical value gives an expansion that is far above the critical. Below the critical value no expansion occurs.

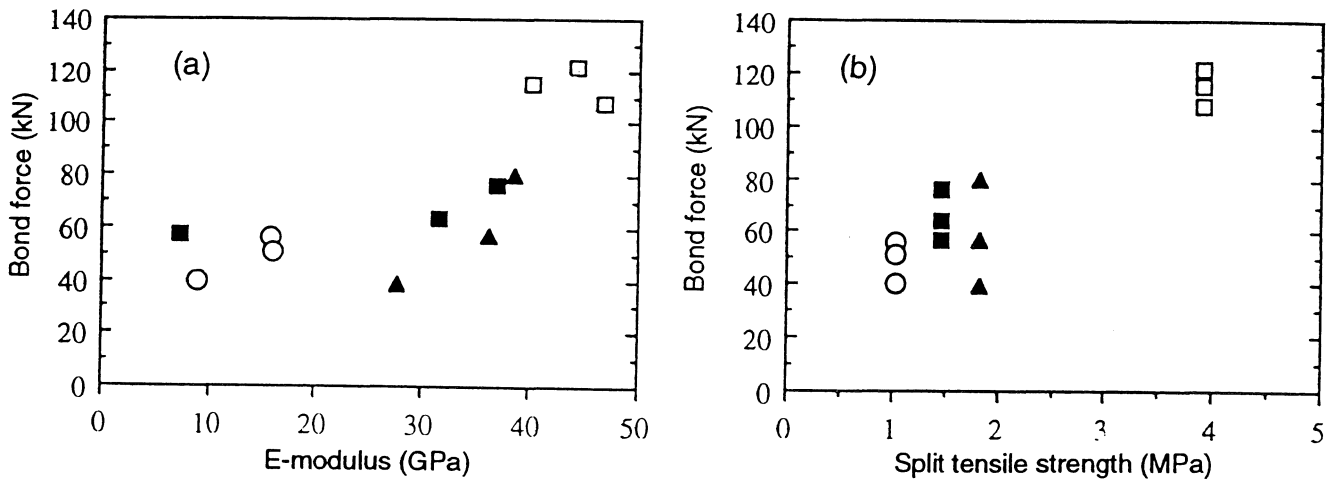

Fig 2: Effect of frost damage on, (a) the E-modulus of the concrete, (b) the bond between reinforcement and concrete ; Fagerlund et al [1993]. On the y-axis is the force in the bar needed for bond fracture.

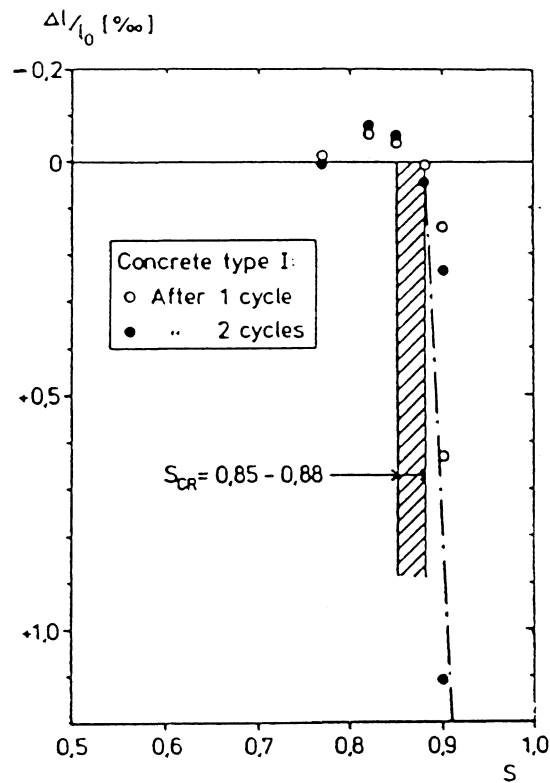

Fig 3: Relation between the degree of saturation, and the permanent frost-induced expansion of a concrete; Fagerlund [1977A].

Another example is seen in Fig 4. Specimens prepared from two types of concrete, one with air-entrainment (Type I), the other without (Type II), were exposed to 6 freeze/thaw cycles in moisture isolated condition, and with different amount of water inside the specimen. The critical degrees of saturation were 0,80 and 0,90. Also a small transgression of this value gave a very large reduction in the E-modulus.

Degree of saturation, S , is defined:

$$S=W_e/P \quad (1)$$

Where

- W_e the total amount of evaporable water in the concrete (m^3 per m^3 of concrete)
 P the total pore volume in the concrete (including air-pores and pores in the aggregate, and pores at the interfaces) (m^3 per m^3 of concrete)

In Fagerlund [1994A], on the basis of results of freeze/thaw tests, the following relation between the damage and the number of freeze/thaw cycles is derived,:

$$\begin{aligned} S \leq S_{CR}: & \text{ Damage}=0 \\ S > S_{CR}: & \text{ Damage}=K_N(S-S_{CR}) \end{aligned} \quad (2)$$

Where

- K_N a coefficient, that describes the extent of damage
 S_{CR} the critical degree of saturation of the concrete

Thus, S_{CR} is a sort of *fatigue limit* with regard to frost attack.

The coefficient K_N is high. In Fagerlund [1994A] the following relation is given for the concretes in Fig 4, when damage is defined as % reduction of the E-modulus:

$$K_N=1350 \cdot N/(4,1+N) \quad (3)$$

50% reduction in the E-modulus of concrete type II in Fig 4 occurs after 12 cycles only when $S=0,85$ and after 3 cycles when $S=0,90$.

This means, that *there is in fact no fatigue effect involved in internal frost damage*. Therefore, the concrete cannot be allowed to become critically saturated, even once, during its entire service life of 100 years.

The fact that many researchers have found, that an increased number of repeated freeze/thaw cycles cause a gradual increase of damage, is not any proof of the existence of a true fatigue phenomenon. It only reflects the fact, that the water content in the specimen gradually increases with increasing number of cycles, thus bringing a bigger and bigger portion of the specimen into a more than critically saturated condition.

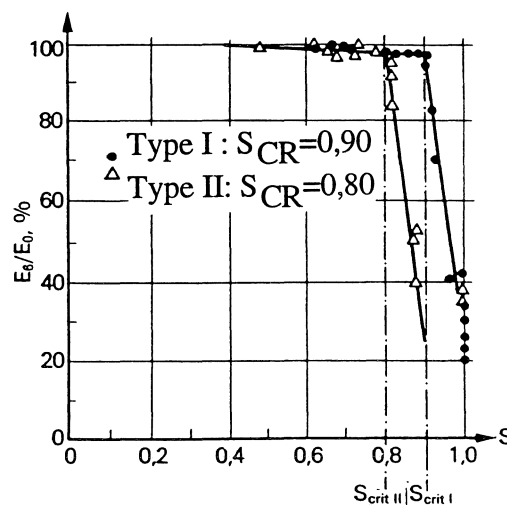

Fig 4: Relation between the degree of saturation of two types of concrete, and the dynamic E-modulus after 6 freeze/thaw cycles in moisture isolated condition; Fagerlund [1977A].

2.2.2 Surface scaling

Surface scaling, due to salt-frost attack, is normally not accompanied by internal damage. It only affects the surface, which is gradually scaled off, reducing the concrete cover, thereby causing reduced structural performance due to reduced anchoring capacity of the reinforcement, and/or aesthetic damage.

Another important effect of salt scaling is its negative influence on the service life with regard to reinforcement corrosion. This effect is treated in detail in Fagerlund et al [1994]. A short summary is given in the following.

The differential equation describing the penetration of the threshold chloride concentration, *without surface scaling*, is:

$$dx/dt = C_{Cl} \cdot t^{1/2} \quad (4)$$

Where

dx/dt	the rate of penetration of the threshold concentration (m/s)
C_{Cl}	the rate determining constant for chloride penetration (m/s ^{1/2})
t	the exposure time (s)

The differential equation describing the same penetration in the case where *the surface is gradually eroding due to frost* is:

$$(x - C_e \cdot t) dx/dt = \{C_{Cl}^2\}/2 \quad (5)$$

Where

C_e	the rate determining constant for erosion defined by eq (6)
-------	---

$$(dx/dt)_e = C_e \quad (6)$$

Where

$(dx/dt)_e$	the rate of erosion (m/s)
-------------	---------------------------

An example of the use of eq (4) and (5) is shown in Fig 5. The concrete cover is assumed to be 30 mm. The time until start of corrosion is 100 years when there is no erosion, but only 43 years when there is erosion due to frost scaling. This example shows, that salt scaling must be avoided, also with regard to the protection against reinforcement corrosion.

The salt scaling is either accelerated with increasing number of freeze/thaw cycles, or linear, or retarded; see Fig 6. For a concrete with high salt scaling resistance, the scaling is normally linear or retarded. When the scaling is high, it is also normally accelerated, and finally leads to complete destruction of the entire concrete cover. In a large study with about 100 different concrete types, it was found that, for most concretes, the limit between retarded and accelerated scaling corresponded to a total scaling of about 0,6 kg/m² after 28 salt scaling cycles of a type similar to that in the Swedish test method SS 13 72 44; see Fig 7 which shows the "acceleration factor" β as function of the total scaling after 28 freeze/thaw cycles in 3% NaCl-solution. $\beta > 1$ corresponds to accelerated scaling and $\beta < 1$ corresponds to retarded scaling. The total number of cycles in the test was about 50. When the scaling is very low -below about 0,2 kg/m² after 56 cycles- it is often meaningless to talk about retarded or accelerated scaling, due to the difficulty in measuring exactly such small scalings. If the total scaling is below 0,2 kg/m² after 56 cycles, an accelerated scaling will probably not lead to big scalings, even after numerous cycles

Some examples of scaling curves for air-entrained concretes, tested in 3 % NaCl-solution, are shown in Fig 48. They are all retarded. The fact, that the first cycles often produce the biggest scaling, can probably be explained by the fact, that normally the surface is a bit weaker than the interior, due to separation, and to deficient moist curing.

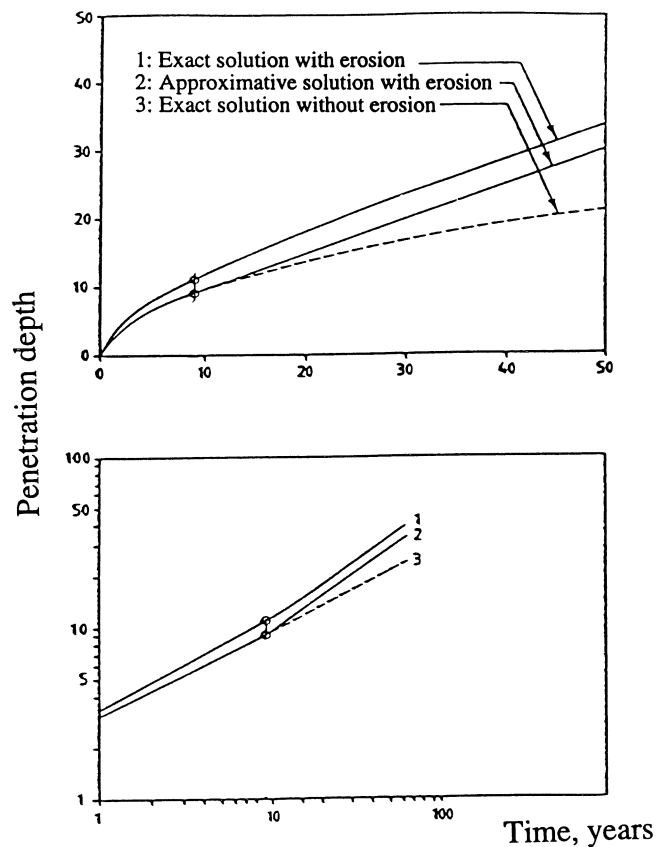

Fig 5: The penetration-time curve of the threshold chloride concentration without and with surface erosion; Fgerlund et al [1994]. ($C_{Cl}=3 \cdot 10^{-3} \text{ m} \cdot \text{year}^{-1/2}$; $C_e=5 \cdot 10^{-4} \text{ m/year}$; Concrete cover=30 mm).

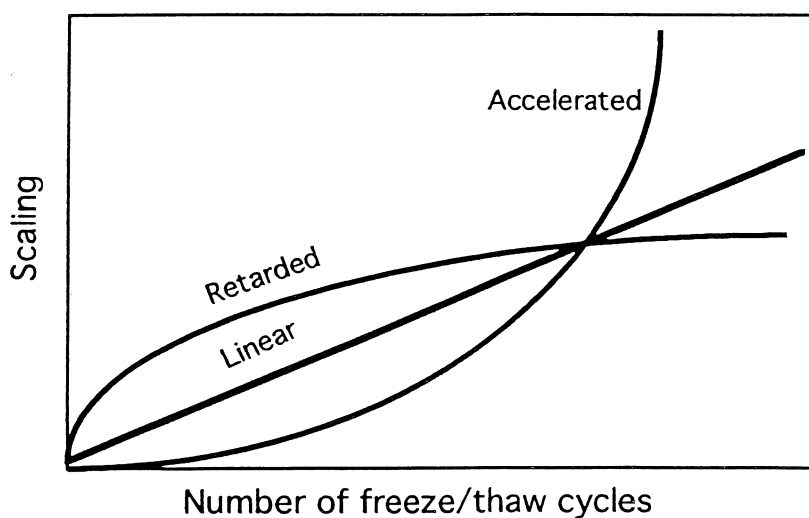

Fig 6: Three types of salt scaling; accelerated, linear, retarded.

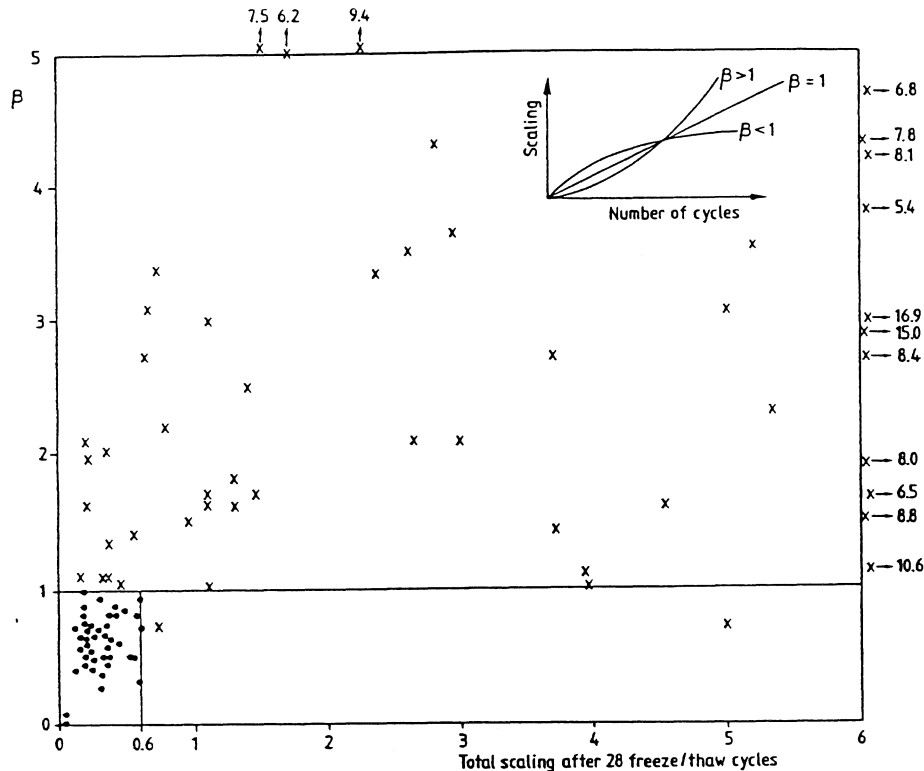

Fig 7: The effect of the total scaling after 28 salt scaling cycles on the "acceleration factor β "; (unpublished results from tests performed by the author at the Swedish Cement and Concrete Research Institute, 1980).

There are, however, exceptions to this general relation between the number of cycles, the amount of early scaling, and the shape of the scaling curve shown in Fig 7. Some examples are shown in Fig 8. One of the concretes is an air-entrained Portland cement concrete. It exhibits retarded scaling. The other two concretes are also air-entrained, but are based on a combined binder of Portland cement and silica fume. The scaling of these two concretes is low and retarded during 50 or 100 cycles. Then, a very rapid and accelerated scaling starts. Similar behaviour has also been observed for concrete containing particulate airpore admixture consisting of hollow plastic spheres (Kleenopor); see Sommer [1978]. A plausible explanation is that the smallest airpores gradually become water-filled during the test, due to a "dissolution-of-air, absorption-of-water process"; Fagerlund [1993A]. The smaller the pore, the more rapid the water-filling. Therefore, an air-pore system containing a large portion of very small airpores gradually becomes inactivated. It is well-known that microsilica often creates very fine air-pore systems.

In reality, the scaling curve is not completely smooth but more or less discontinuous. This depends on the fact that the cement paste scaling gradually undermines sand grains, and, finally, even coarse aggregate grains. Sooner or later they loosen from the concrete, and then, the scaling curve makes a jump upwards. Loosening of coarse gravel grains is a sign of an inferior salt scaling resistance.

It is quite evident, that the total number of severe freeze/thaw cycles is of great importance for the amount of scaling. One can, therefore, say, that the scaling is a sort of *fatigue phenomenon*. This must be considered in the design and interpretation of a salt scaling test, a problem which will now be discussed briefly.

Each freeze/thaw cycle, with a salt concentration of pessimum concentration, gives a certain scaling, the amount of which depends on the severeness of the cycle. As will be shown in paragraph 4.1 the lowest freezing temperature is of major importance for the amount of scaling;

see Fig 21-24. The scaling at -22°C is more than 10 times bigger than at -14°C . It is unlikely that a temperature cycle, from the unfrozen state to less than -20°C , in the concrete surface, occurs more than 10 times a year. This gives a total number of very severe cycles of less than 1000 during 100 years. The density of a saturated cement paste of high quality is about 2000 kg/m^3 and the density of the cement mortar is about 2200 kg/m^3 . This means, that a maximum acceptable total scaling of $D\text{ mm}$ after 100 years corresponds to a total weight loss after 100 years of $2\cdot D\text{ kg/m}^2$. The average scaling during one cycle, therefore, must be below $2\cdot 10^{-3}\cdot D\text{ kg/m}^2$. A typical salt scaling test normally has a duration of 56 cycles. Therefore, the maximum acceptable scaling at the end of the test is $0,11\cdot D\text{ kg/m}^2$.

The following approximate relationship between the maximum acceptable scaling depth after 100 years, and the weight loss after 56 cycles in a salt scaling test, is valid.

D=5 mm:	Max scaling $0,5\text{ kg/m}^2$
D=10 mm:	Max scaling $1,1\text{ kg/m}^2$
D=15 mm:	Max scaling $1,6\text{ kg/m}^2$

The calculation is probably on the safe side, due to the following reasons:

- * In reality, during normal climatic conditions, the number of very severe freeze/thaw cycles down to very low temperature is less than 1000 in a 100 year period.
- * In reality, all the freezings to very low temperature do not occur with the same very moist condition at the surface, as in the salt scaling test. In this, the concrete has no possibility to dry between the freeze/thaw cycles.
- * In reality, but not in the test, the concrete has a certain possibility to heal between the individual freeze/thaw cycles.

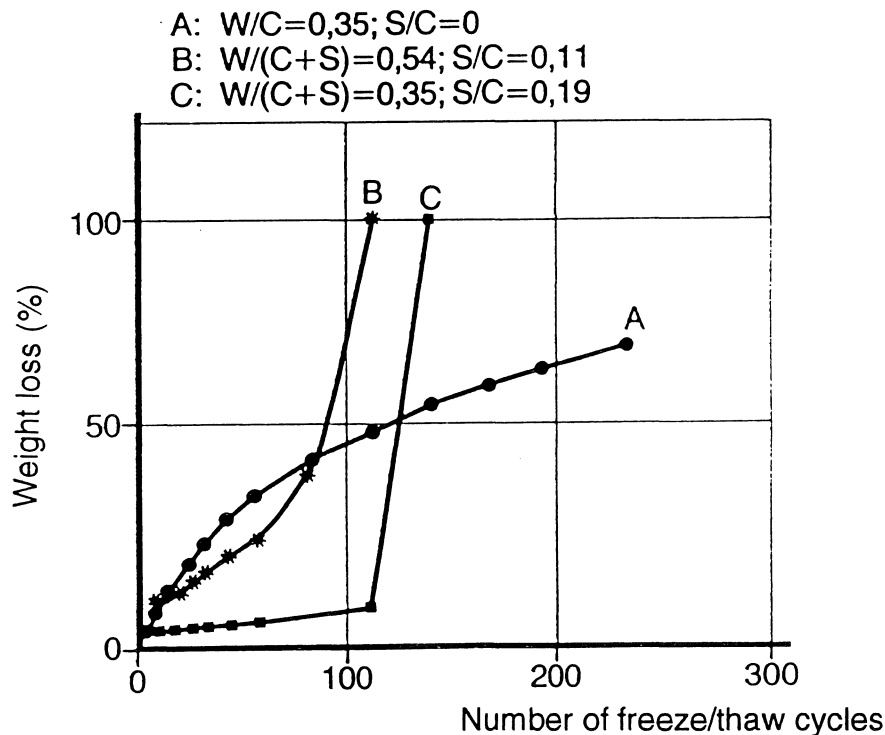

Fig 8: Examples of retarded and accelerated salt scaling curves; Petersson [1986]. (S= silica fume; C=portland cement; W=water).

3. Freezing of water in the concrete

3.1 Water in the cement paste

The cement paste always contains water, that is potentially freezable at normal temperatures. By "potentially freezable" is meant, that the water is located in pores which are coarse enough to contain an ice crystal at normal freezing temperatures. The fact that it is "potentially freezable" does not necessarily mean that it actually freezes. Super-cooling phenomena frequently occur, and the potentially freezable water, therefore, often stays unfrozen until it freezes by homogeneous nucleation around -40°C . This is further discussed in Fagerlund [1994B].

The amount of potentially freezable water in saturated cement pastes was determined already by Powers and Brownard [1948]. The result of an interpretation of their data is shown in Table 1 taken from Fagerlund [1994B].

Also dense concretes, with low water/cement ratio, contains large amounts of potentially freezable water. It can be shown, that no freezable water exists in the cement paste if the degree of hydration of the concrete is very high; the following relation between the required degree of hydration α_{req} and the maximum possible degree of hydration, α_{max} is valid for a freezing temperature of -20°C ; /8/:

$$\alpha_{\text{req}}/\alpha_{\text{max}} = 0,91 \quad \text{for } w/c \leq 0,40 \quad (7)$$

A degree of hydration of this magnitude will not be reached within the first decade or decades. During this period, the freezable water is high enough for considerable frost damage to occur.

All the potentially freezable water can only be nucleated when the concrete has undergone some sort of ageing, creating a microcrack system in the cement paste. The mechanism is described in Fagerlund [1994B]. Drying/wetting cycles are an example of such ageing.

The effect of a rather mild drying, on the increase in freezable water, has been observed by Bager and Sellevold [1982], and others. The effect of hard drying is shown in Fig 9. A never-dried concrete with the w/c-ratio 0,30 seems to have very little freezable water. After a drying ($+105^{\circ}\text{C}$) and resaturation cycle, the freezable water is high also in such a dense concrete. It almost exactly corresponds to the capillary porosity of the concrete; see Fagerlund [1994B]. Another example of the effect of drying on the amount of ice at different temperatures is seen in Fig 13 below.

It can also be shown theoretically, that a very small amount of freezable water is able to destroy the concrete. A water content of less than 10 litres per m^3 can be high enough to cause frost damage, *provided the concrete is completely saturated*; Fagerlund [1993B]

The requirement that the concrete shall survive 100 years without frost damage implies, that one must assume, that at least some small portion of the potentially freezable water can be activated. If this occurs, and the concrete does not contain any air, it will suffer great damage.

In order to protect the concrete from frost damage, air-entrainment is needed. The amount of air required is discussed below in paragraph 7. It is individual for each concrete, and it shall be based on experimental studies of the behaviour of the actual concrete under freeze/thaw action. It shall never be allowed to be lower than a certain minimum value. The test method for determining this is presented in paragraph 10.

Table 1: Potentially freezable water in saturated Portland cement paste at a degree of hydration that is 75 % of the maximum possible. The calculations are based on the Powers and Brownard data [1948] [w_e =evaporable water (kg); w_f =freezable water (kg); c = cement content (kg)]

w/c	W_e/c	-12°C		-20°C		-30°C	
		w_f/c	w_f/w_e	W_f/c	w_f/w_e	w_f/c	w_f/w_e
0,20	0,129	0,031	0,24	0,039	0,30	0,050	0,39
0,30	0,193	0,047	0,24	0,058	0,30	0,075	0,39
0,40	0,258	0,063	0,24	0,078	0,30	0,100	0,39
0,50	0,358	0,163	0,46	0,178	0,50	0,200	0,56
0,60	0,458	0,263	0,57	0,278	0,61	0,300	0,66

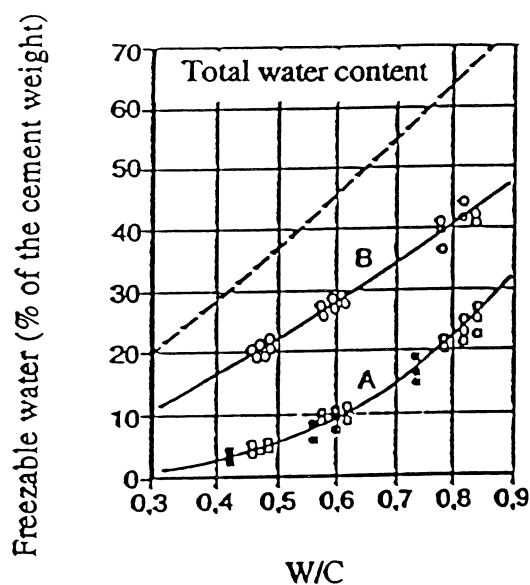

Fig 9: The freezable water in concrete at -15°C; Vuorinen [1973]. Curve A: never dried specimens. Curve B: Pre-dried and re-saturated specimens.

3.2 Water in the aggregate

Aggregate grains containing pores, that are smaller than about 1 mm, can be assumed to be completely saturated when embedded in the cement paste. If the aggregate grain is bigger than a certain critical size, water cannot flow from the aggregate to the cement paste. Instead the grain will expand during freezing, exposing the cement paste to stresses, that can be big enough to destroy the concrete. Equations for calculating those stresses are given in Fagerlund [1978]. An application of the equations is made in Fagerlund [1994B]. There, it is shown that a very small water-filled porosity is enough to destroy the concrete. Theoretically, an aggregate porosity of the order of size 0,5 volume-% is sufficient to cause frost damage, provided the aggregate is completely saturated. If the degree of saturation is reduced to 93%, the aggregate porosity can be allowed to be a bit higher; about 1,5 % to 2 %. These values correspond well with studies made by Larson and Cady [1969]; see Fig 10. According to their findings, an aggregate porosity corresponding to about 1 weight-% of water at full saturation (or 2,5 volume-%) marks the transition from "good" to "average" frost resistance.

The problems with porous aggregate increase with increasing aggregate size, which is reasonable since water from a small aggregate can escape without causing damage. The criterion for the critical aggregate size is treated in Fagerlund [1978]. An experimental investigation of the effect of the size of the aggregate on the expansion of the concrete during a frost cycle is

seen in Fig11. The critical aggregate size evidently depends on the water/cement ratio. 6 mm aggregate does not cause damage when the w/c-ratio is below 0,55, but it does so when the w/c-ratio is 0,60. The soundness of the aggregate must be investigated by freeze/thaw testing of concretes containing the aggregate; see paragraph 10.4.

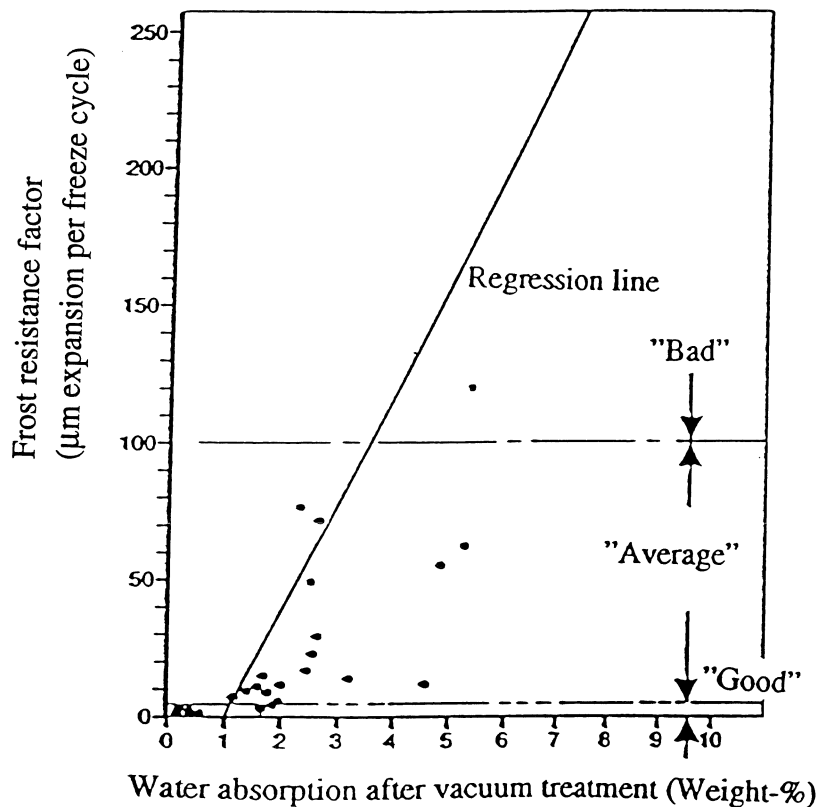

Fig 10: Expansion at freezing of concrete as function of the vacuum saturated porosity of the aggregate; Larson and Cady [1969].

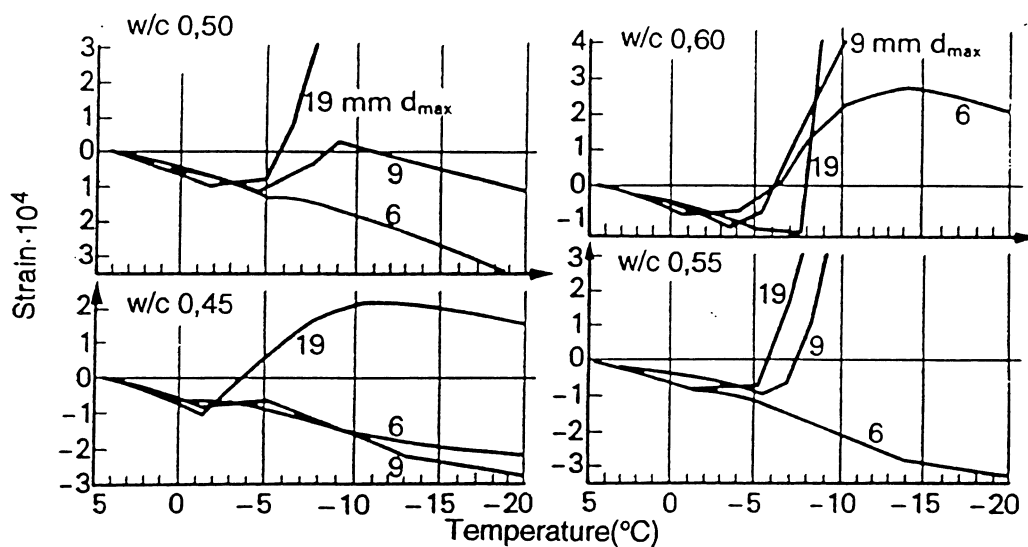

Fig 11: Expansion during freezing of concrete containing porous natural aggregate. Effect of aggregate size and water/cement ratio; MacInnis and Lau [1971].

3.3 Water in air-pores

Air-pores take up water when the concrete is stored in water during shorter or longer periods. The process is described in Fagerlund [1993A]. The finer the pore, the more rapid the water absorption. The water absorption process can be described by the following type of equation:

$$S_a(t) = A \cdot \alpha_o^B \cdot t^C \quad (8)$$

Where

- $S_a(t)$ the degree of saturation of the air-pore system after time t of continuous water storage ($S_a=0$ when no air-pore contains water; $S_a=1$ when all pores are filled)
- A; B; C coefficients
- α_o the specific area of the empty air-pore system (m^{-1})
- t the water absorption time (s)

Thus, the finer the air-pore system (the higher the value of α_o), the more rapid the water absorption. Theoretically, for some types of air-pore systems, the coefficient C is a function of the fineness of the air-pore system; the higher the specific area, the larger the value of C , and the more rapid the water absorption.

The gradual water-filling of the air-pore system has two effects:

- 1: The finest portion of the air-pores, becoming water-filled quite readily, does not protect the concrete from frost damage. Therefore, *the so-called Powers spacing factor, see paragraph 6.1, loses its meaning as a criterion for frost resistance*. Fine-porous air-pore systems give a low Powers' spacing factor, but they also readily take up water. Therefore, the *real* spacing factor between air-pores, that are *actually air-filled*, might even be higher for a fine-porous air-pore system than the real spacing factor for a more coarse-porous air-pore system. Besides, the more wet the environment, the larger the portion of water-filled airpores, and the larger the real spacing factor. Thus, the real spacing factor is a function of the wetness of the environment, while the Powers' spacing factor, which is based on all air-pores, is constant.
- 2: The amount of freezable water increases with increasing water absorption in the air-pores. This is of little significance for ordinary concrete, but can be very negative for a high performance concrete with very low water/cement ratio. Such concrete has almost no freezable water, when it contains no air-pores. In such a case where the air content is not high enough for the real spacing between air-filled air-pores to be below the critical spacing factor, water-filled airpores might, therefore, reduce the frost resistance of high performance concrete,

Some examples of the gradual water-filling of air-pore systems are shown in Fig 11. The four concretes have the same w/c-ratio (0,45), and about the same total air content ($\approx 6\%$). The only difference is the amount of ground granulated slag, that is interground with the Portland clinker. The higher the slag content, the more rapid the water absorption in the air-pore system. The most plausible explanations to this negative effect of slag are:

- 1: The general trend of the investigated cements and concretes was, that the specific area of the air-pore system increased with increased slag content. Theoretically, this will cause an increased absorption rate; see Eq (8).
- 2: The diffusivity of dissolved air in the water-filled capillary pore system might increase with increasing slag content.

The first effect was observed experimentally; Fagerlund [1982]. The second effect is only a hypothesis.

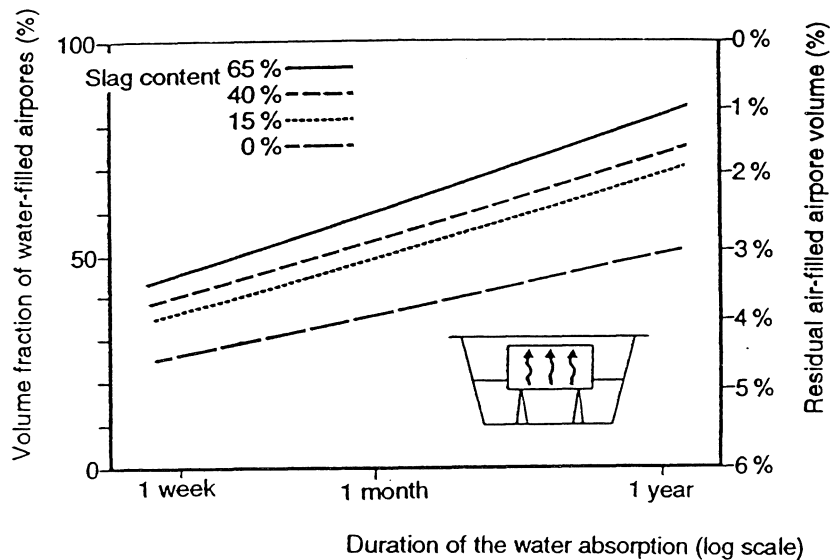

Fig 12: Example of the long-term water absorption in the air-pore system of concrete made with cement containing different amount of ground granulated blastfurnace slag; Fagerlund [1982].

3.4 Water in continuous air-pores

When an unsuitable air-entraining agent is used, an agent that is not adjusted to the chemical characteristics of the actual fresh concrete, the air-pores might be unstable and agglomerate in more or less continuous strings of pores. Such a continuous air-pore system will absorb water very rapidly. It will not be a protection against frost damage, but a source of destruction.

Such an instability of the air-pores can occur when the combination of the water reducing agent and the air-entraining agent is unsuitable; see paragraph 9.4. It might also occur when the chemistry of the cement (binder) does not fit the admixtures. It has often been found, that a high-alkali cements and high-alkali fly ash give more unstable and more coarse-porous air-pore systems than low-alkali binders; Mielenz et al [1958], Pistilli [1983], Fagerlund [1988].

Field studies have been made of concretes, in which unsuitable combinations of cement, air-entraining admixture and water reducing admixture have been used. One example is given in Fagerlund [1990A]. Studies of thin sections, taken from the hardened concrete, revealed a highly continuous air-pore system, probably caused by an instability of the air-pores during transport and casting, and perhaps even caused by air-pore agglomeration caused by the movement of air-bubbles within the fresh concrete mass, after the concrete was placed, but before hardening; Fagerlund [1990B].

3.5 Water in deep cracks

Cracks, that are open to the surface, can easily become water-filled. When the water freezes, it exposes the concrete to stresses. If the crack is thin, the water expelled, due to the 9% increase in volume at transformation into ice, can flow into the cement paste, where it is accommodated in the nearest air-pores. On the other hand, if the crack is wide, and the air content in the concrete is low, water cannot be taken care of in the cement paste without causing some sort of destruction.

The relation between crack width, air content, and amount of freezable water in the concrete, has been derived in Fagerlund [1994B]. The analysis shows that normal air contents are sufficiently high to take care of water in rather wide cracks. *Example:* A crack with a width of about 0,75 mm can be accepted, provided the air content in the cement paste phase is at least 12 % (≈ 4 % in the concrete).

3.6 Water in interfaces

The interface between the aggregate and the cement paste is more porous than the cement paste in bulk. The thickness of a *normal interface zone* is about 20 μm ; Scrivener and Gartner [1987]. It is assumed, that this zone consists of 50 % of coarse pores. The interface zone to coarse aggregate is supposed to be a bit thicker, due to water separation. Its porosity is supposed to be 100 %. If the whole interface area is regarded, the average thickness might be 50 μm or more.

Assumption 1: Only coarse aggregate is regarded. The interface thickness is assumed to be 50 μm , consisting of 100 % pore volume.

The total envelope area of coarse aggregate is:

$$A_{c.a.} = 3 \cdot g_{c.a.} / r_{c.a.} \quad (9)$$

Where

- $A_{c.a.}$ the envelope area of coarse aggregate (m^2/m^3 of concrete)
- $g_{c.a.}$ the volume fraction of coarse aggregate (m^3/m^3 of concrete)
- $r_{c.a.}$ the average radius of coarse aggregate (m)

The total volume of the interface zone of coarse aggregate is:

$$(V_{i})_{c.a.} = A_{c.a.} \cdot t_i = 3 \cdot g_{c.a.} \cdot t_i / r_{c.a.} \quad (10)$$

Where

- t_i the thickness of the interface zone (m)

Let us assume, that the fraction of coarse aggregate is 35 %, and that the average radius of the grain is 12,5 mm. Then, the interface volume is:

$$(V_{i})_{c.a.} = 3 \cdot 0,35 \cdot 50 \cdot 10^{-6} / 12,5 \cdot 10^{-3} = 0,004 \text{ m}^3/\text{m}^3 \text{ or } 0,4 \%$$

This is probably too small an amount of freezable water to cause severe frost damage in a non-air-entrained concrete. If the interface is somewhat thicker, it will damage the concrete, provided this is water saturated. Air-entrainment will protect the concrete from the pressure that is exerted by water, that is freezing in the interface.

Assumption 2: All aggregate is regarded. The interface is supposed to be 20 mm for fine aggregate with 50 % of coarse porosity, and 50 mm for coarse aggregate with 100 % porosity.

The specific area of the fine aggregate can be calculated from the sieve curve, assuming all grains being spherical; see Fagerlund [1977B]. A typical specific area of fine aggregate is about 12 mm^{-1} . This means that the average radius of the grain is about 0,25 mm. The same formulas as above are used; eq (9) and (10). The amount of fine aggregate is assumed to be $0,35 \text{ m}^3/\text{m}^3$. Then, the total volume of the interface zone is:

$$V_i = 3 \cdot 0,35 \cdot 50 \cdot 10^{-6} / 12,5 \cdot 10^{-3} + 3 \cdot 0,35 \cdot 0,5 \cdot 20 \cdot 10^{-6} / 0,25 \cdot 10^{-3} = 0,046 \text{ m}^3/\text{m}^3 \text{ or } 4,6 \%$$

This is a very high amount of freezable water, which will cause frost damage in a non-air-entrained concrete. The calculations are very approximative. They indicate, however, the fact, that if porous interfaces exist, they will make it necessary to have some air-entrainment in the concrete, even when this is very dense, and when it does not contain any freezable water within the bulk cement paste.

4. Effect of the freezing temperature; The destruction mechanisms

4.1 Effect of the lowest temperature

The amount of ice formed increases with decreasing temperature. Some examples are seen in Fig 13. Evidently, the amount of ice is also a function of the pre-treatment of the concrete, as was shown in paragraph 3.1. This does, however, not necessarily mean that the internal pressure increases with decreasing temperature. According to *the hydraulic pressure mechanism*, which was for the first time expressed in quantitative terms by Powers [1949], the internal pressure (the hydraulic pressure) is a function of *the rate of ice formation*, but not on the total amount of ice formed. The Powers theory can be formulated:

$$P_h = 0,09 \cdot (dW_f/dt) \cdot (1/K) \cdot f(X) \quad (11)$$

Where

P_h	the internal, hydraulic pressure (Pa)
dW_f/dt	the rate of ice formation [$m^3/(m^3 \cdot s)$]
K	the permeability [$m^2/(Pa \cdot s)$]
$f(X)$	a measure of the maximum distance of flow of expelled water (m^2)

The factor 0,09 is the volume expansion when water is transformed to ice. This generates a water flow that is $0,09 \cdot W_f$. The rate of ice formation can be formulated:

$$dW_f/dt = (dW_f/d\theta) \cdot (d\theta/dt) \quad (12)$$

Where

$dW_f/d\theta$	the increase in freezable water per degree of temperature lowering [$m^3/(m^3 \cdot \text{degree})$]
$d\theta/dt$	the rate of temperature lowering of the concrete (degree/s)

$dW_f/d\theta$ is nothing else but the derivative of the freezable water curves in Fig 13. Since the freezable water content decreases with decreasing temperature, the internal pressure should in fact also decrease with decreasing temperature. Observations indicate, however, that the expansion of a specimen, that is more than critically saturated, increases gradually with decreasing temperature; see Fig 18, 19 and 27. This can be explained by the Powers' theory, provided the permeability is also reduced with reduced temperature. A possible cause of this reduction is the ice formation inside the dense capillary pore system. In Fagerlund [1975] a simple analysis is made, that indicates that the reduction in permeability can in fact be bigger than the reduction in the rate of ice formation. This probably explains the observations in Fig 18, 19 and 27, and other observations of the same type. Therefore, there is not necessarily a contradiction between the hydraulic pressure mechanism and observations of the expansion at very low temperature.

It is also found experimentally, that a rather rapid ice formation might occur at rather low temperatures -at least in cement paste; see Fig 14. This would further increase the inner pressure at low temperature.

The other main mechanism, describing the inner pressure during freezing, is *the microscopic ice crystal (or ice lens) growth mechanism*. This has been treated by numerous authors. It was first applied to concrete by Powers and Helmuth [1953]. According to this theory, ice crystals in capillary pores attract unfrozen water in finer pores. Water transfer is propelled by the energy differential between ice and unfrozen water. The lower the temperature, the larger the energy differential. When water arrives at the ice crystal, it freezes. Then, the ice crystal grows and exposes the pore wall to a pressure. This pressure increases the free energy of the ice, at the same time as the free energy of the unfrozen water decreases, due to the drying ef

fect caused by the water transfer. The water transfer will cease when the two free energies are equal. If the amounts of ice and unfrozen water are big, the pressure can become very high, before water transfer and ice growth ceases.

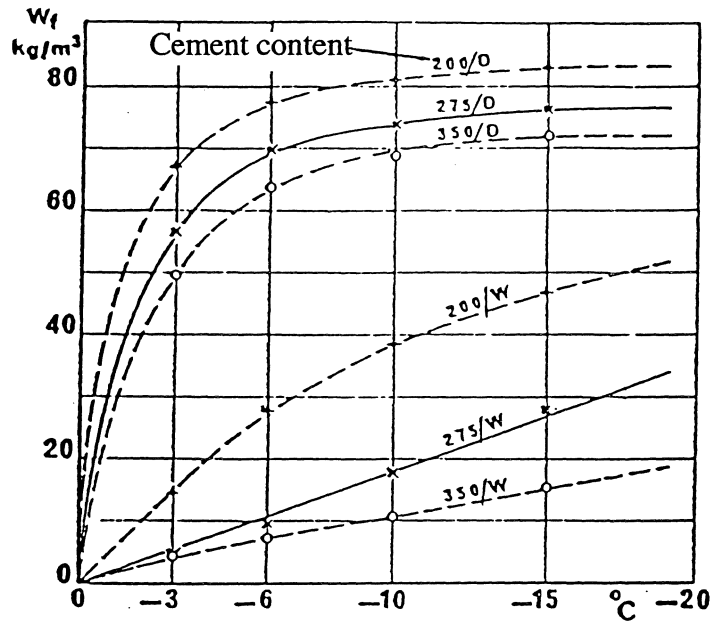

Fig 13: The relation between the freezing temperature and the amount of water frozen; Vuorinen [1973]. (W: never-dried specimens; D: pre-dried and re-saturated specimens.)

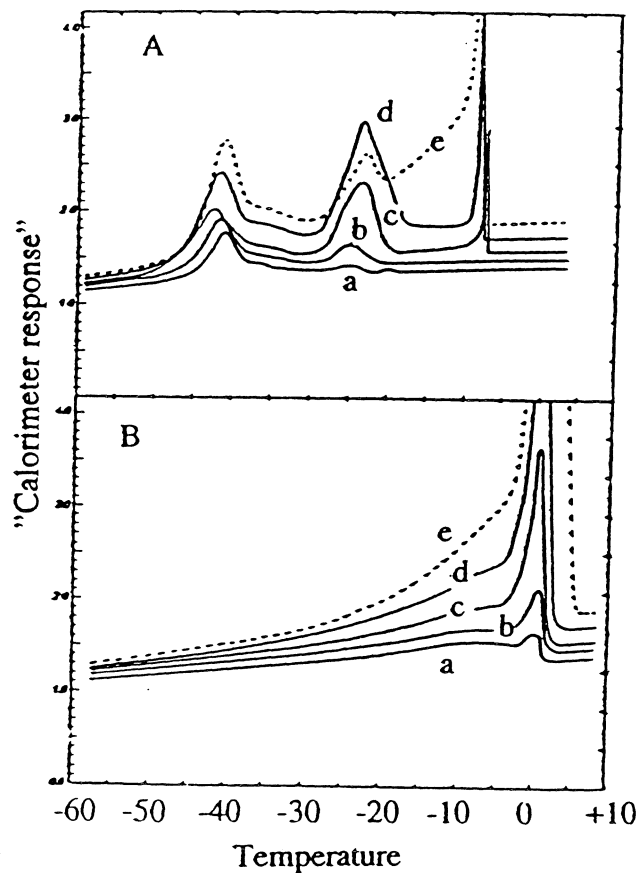

Fig 14: Calorimeter measurements on saturated cement pastes with different water cement ratio, (A) freezing curves; (B) thawing curves. Bager and Sellevold [1982]. (a. $w/c=0,35$; b. $w/c=0,40$; c. $w/c=0,45$; d. $w/c=0,50$; e. $w/c=0,60$)

According to this mechanism, expansion of the concrete can occur also when the temperature is held constant at low temperature. This is not possible according to the hydraulic pressure mechanism. It also predicts that the internal pressure increases with decreasing temperature, all other factors kept constant. In reality, there is probably a combined effect of the two mechanisms. Which one is dominant is difficult to know. The hydraulic pressure should theoretically be most pronounced for concrete with a high fraction of freezable water (high w/c-ratio), while the microscopic ice crystal growth for concrete with a large portion of unfreezable water (low w/c-ratio).

As shown in Fig 18, 19 and 27, one can assume that the highest pressure with regard to *internal damage* is reached at the lowest temperature. The same seems to be valid for *salt scaling*; see Fig 21-24, showing that the scaling increases with decreasing freezing temperature. The minimum temperatures -7 and -14°C produces rather small scaling. The freezing temperature -22°C, on the other hand, produces heavy scaling of the actual concrete. The following approximative relation between the salt scaling per cycle, ΔQ , and the minimum freezing temperature, θ_{\min} , can be derived on basis of the results in Fig 21-24:

$$\Delta Q = \text{Constant} \cdot |\theta_{\min}|^2 \quad (13)$$

Conclusion: It is important that a freeze/thaw test of a concrete is made with a minimum freezing temperature, that is representative for the actual climate. This means, that the minimum temperature for concrete to be used in the Öresund area, ought to be less than -20°C. A reasonable minimum temperature is -22°C. This value is also below the eutectic temperature for NaCl-solution (-21°C). The lowest temperature shall be kept constant for some time during each cycle, making ice crystal growth possible.

4.2 Effect of the rate of freezing

4.2.1 Moisture isolated freeze/thaw

The maximum rate, in nature, of temperature lowering of concrete, might vary by a factor of about 2, from about 1,5°C/h to about 3°C/h. According to the hydraulic pressure theory, this means that, the internal pressure also might vary by a factor of about 2. Thus, an increased freezing rate should impose more damage to the concrete. One can calculate theoretically, that the so called critical spacing factor decreases by about 25% when the freezing rate is doubled; Fagerlund [1994A]. Therefore, the air content must be increased somewhat, if the frost resistance shall remain on the same level. In this calculation it is assumed that there is no moisture exchange between the concrete and its surroundings during freezing; i.e. the freeze/thaw is moisture isolated.

Two examples of the effect of the rate of freezing on the so-called critical degree of saturation is seen in Fig 15, taken from an international cooperative test. The critical degree of saturation is a measure of the maximum amount of water in the concrete, which does not produce damage when it freezes. The rate of freezing of the concrete varied by a factor 3,7. The critical degree of saturation somewhat decreased with increased freezing rate, but the effect was not as big as one might expect. This can be explained theoretically; see Fagerlund [1994A].

The ice crystal growth mechanism is not promoted by rapid freezing, but by keeping a low temperature constant for a long time. Then, the internal moisture migration has time to develop. The rate by which the lowest temperature was reached ought to be of less significance.

Conclusion: A test method based on isolated freeze/thaw, e.g an expansion test for determination of the potential frost resistance of the aggregate in concrete (see paragraph 10.4), shall be performed with the maximum possible rate of temperature lowering occurring in practice. This gives the highest possible internal hydraulic pressure. The lowest temperature shall be kept during a certain time, making also ice lens growth possible.

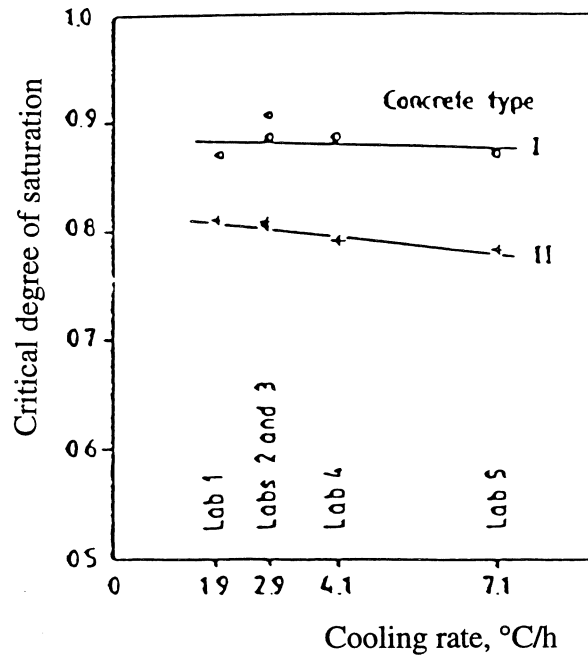

Fig 15: The effect of the rate of freezing on the critical degree of saturation of two types of concrete; Fagerlund [1977A].

4.2.2 Unisolated freeze/thaw

If the concrete is unprotected from drying or moisture uptake during freeze/thaw, the effect of an increased freezing rate can be both positive and negative. Which effect occurs, depends on the shape of the freeze/thaw cycle. If the cycle is "moist", meaning that the concrete has the possibility to take up water, a slower cycle might be negative, simply because the water absorption is bigger. On the other hand, if the cycle is such that the concrete has a small possibility to take up water during the cycle, an increased freezing rate is positive.

There are also many contradictory studies published on the effect of the freezing rate. Most agree upon, that an increased rate is negative, but there are exceptions. The results of a large cooperative study of the 4 ASTM-methods, that were in use some decades ago, are shown in Fig 16 and 17. The 4 methods used were called "slow air", and "rapid air", in which freezing took place in air and thawing in water, and "slow water", and "rapid water", in which both thawing and freezing took place in water. The freezing rate varied by a factor of 3,6 in the two "air methods", and by a factor of 10 in the two "water methods".

Three concrete types were tested. The "water methods" were considerably more harmful than the "air methods". In the "air methods", the more rapid freezing gave somewhat more damage. In the "water methods", on the other hand, the damage was more or less independent of the freezing rate, despite the fact that this varied by a factor of 10. The result of a freeze/thaw test is instead almost totally determined by the "wetness" of the test; the more wet the test, the bigger the damage. This is shown by Table 2 showing the characteristics of the test methods.

Conclusion: An unisolated traditional freeze test method shall be designed in such a way, that the concrete has no possibility to dry during the test, but in such a way, that the water content gradually increases in a manner that corresponds, as closely as possible, to the water uptake during natural conditions.

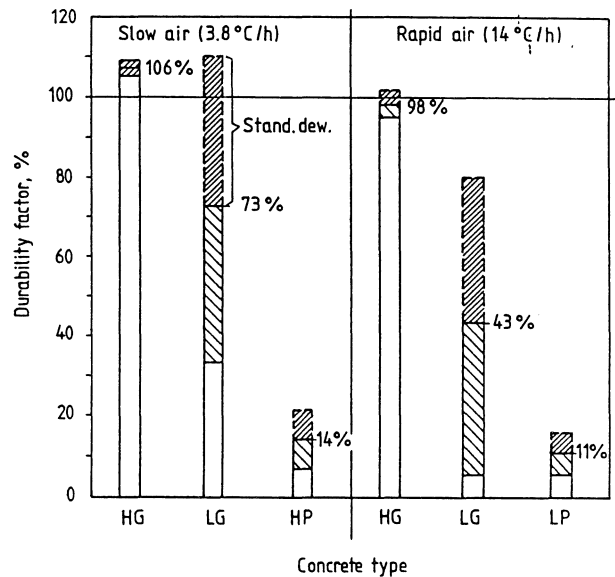

Fig 16: The result of freeze/thaw tests with three types of concrete. The two "air methods"; Anonymous [1959].

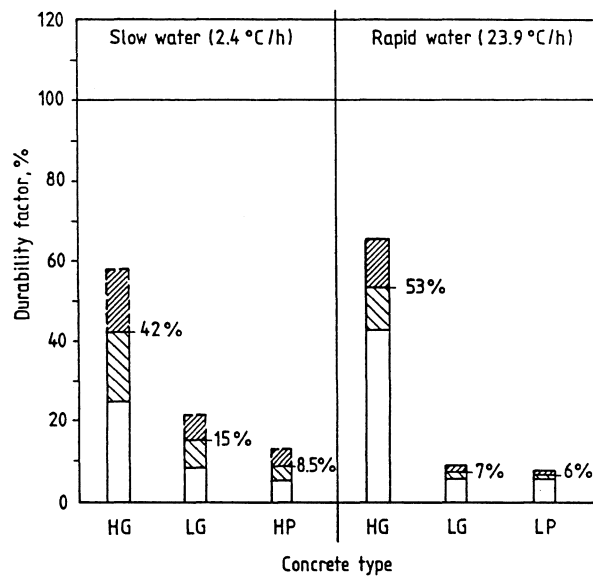

Fig 17: The result of freeze/thaw tests of three concretes. The "water methods"; Anonymous [1959].

Table 2: Characteristics of the 4 ASTM test methods used for the concretes in Fig 16 and 17. Mean values for all laboratories; Anonymous [1959].

Method	Time in air (h)	Time in ¹⁾ water (h)	$\frac{\text{Time in air}}{\text{Time in water}}$	Relative ²⁾ wetness	Mean durability factor
Slow water	0	48	0	1	22
Rapid water	0	3	0	2	22
Rapid air ³⁾	2	1	2	3	51
Slow air	18	6	3	4	64

1) Including the time the specimen is frozen

2) 1 is the wettest; 4 is the driest

3) Principally, rapid air is the present method ASTM C666; see paragraph 10.3

5. Effect of salt solution

5.1 Internal damage in moisture isolated freeze/thaw

In paragraph 3, describing the destruction mechanisms, only pure water was regarded. In reality, the pore water always is a weak salt solution containing different ions (OH^- , SO_4^{2-} , Na^+ , K^+ , Ca^{2+} etc). The concentration is so low that it probably has a marginal effect on the freezing procedure; it might lower the freezing point by perhaps 1 or 2 degrees. If, however, the pore water is more saline, for example after storage of the concrete for a long time in NaCl-solution, there will be considerable effect on the frost resistance. This is seen in Fig 18 and 19 showing the expansion of two types of cement mortar, that have been stored for a very long time, either in pure water, or in NaCl-solution of the concentrations 2,5%, 5% and 10%; /26/. The salt concentration was the same over the entire specimen volume. Three different degrees of saturation were used for every mortar and salt concentration. The specimens were frozen in moisture-isolated conditions.

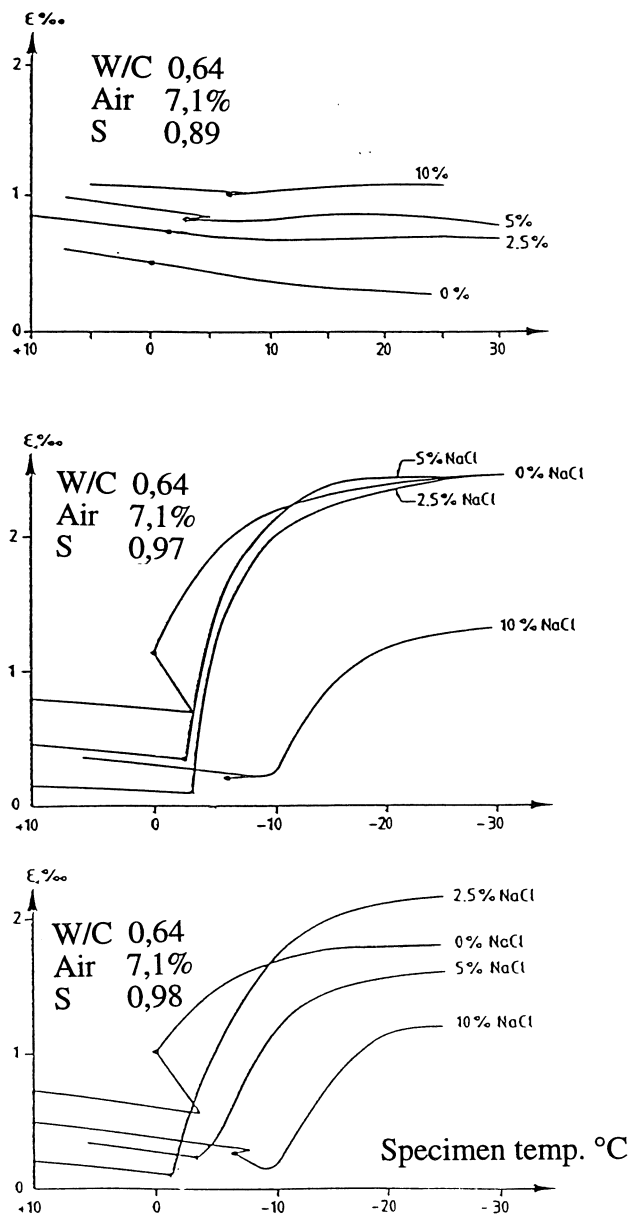

Fig 18: Length change curves of a cement mortar with water/cement ratio 0,64 containing different NaCl-solutions and three different degrees of saturation (S); Fagerlund [1992].

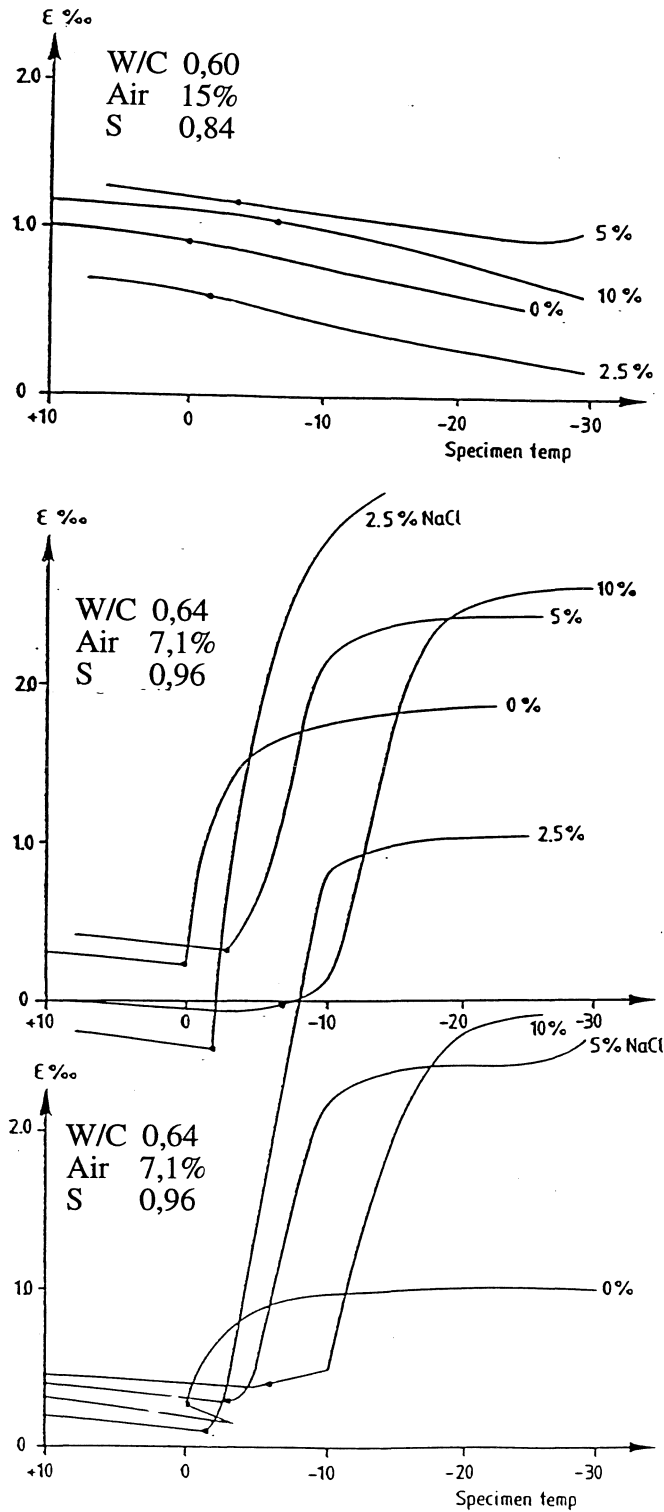

Fig 19: Length change curves of a cement mortar with the water/cement ratio 0,60 containing different concentrations of NaCl-solution and three different degrees of saturation (S); Fagerlund [1992].

The 2,5% solution always gave a bigger expansion than the other concentrations. This is also seen in Fig 20, where the expansion at -25°C is plotted versus the salt concentration and degree of saturation. It is not quite clear why such a pessimum salt concentration occurs. One explanation might be, that the freezable water is reduced with increasing salt concentration, which means that the hydraulic pressure is also reduced. On the other hand, when some of the pore water freezes, the pore will contain an ice body, but also water with enhanced salt con-

centration in comparison with the salt concentration of water in pores, that do not contain any ice-bodies. This will cause an osmotic pressure inside the concrete, that is superimposed on the normal pressure difference between ice and unfrozen water, which was discussed in paragraph 4. The net effect of all the three pressures might be, that there is a pessimum salt concentration somewhere around 2,5 %.

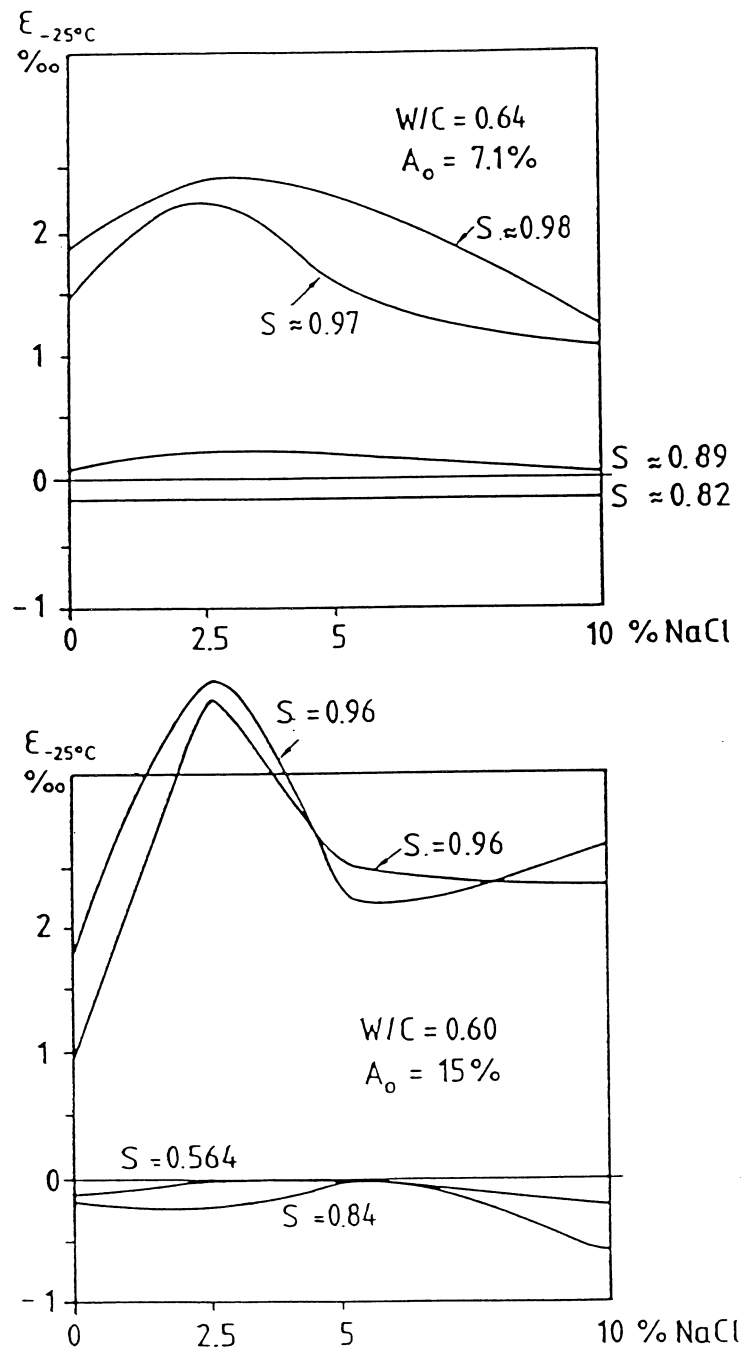

Fig 20: The expansion at -25°C versus the salt concentration of the pore water and with different degrees of saturation. The data are taken from Fig 18 and 19; Fagerlund [1992].

5.2 Salt scaling

It has also been observed in unisolated salt scaling tests, that there exists a certain pessimum concentration of the external salt solution, that stays in contact with the concrete surface during freezing and thawing. Such a test is normally done with specimens, that are water stored for some time before the test starts. Therefore, the capillary pores, and also some of the finest airpores, can be assumed to be saturated when the test starts. The surface of the specimen (or sometimes all surfaces, like in the German and Finnish tests, in which immersed specimens are used) is covered by a layer of a NaCl-solution of a certain concentration (normally 3%). The solution is covered by a plastic foil, so that evaporation during the test becomes impossible. The cycle is normally slow, and consists of about 16 hours of freezing, and 8 hours of thawing. The concrete surface is never allowed to dry. The test, therefore, is very moist. In most cases, only the surface is damaged, but not the interior. The material, that is scaled off, is collected every 7 days. It is dried, and weighed, and expressed in kg per m², where 1 kg/m² corresponds to an average scaling depth of about 0,5 mm.

The results of a determination of the effect of different combinations of the internal and external salt concentrations in such a test is shown in Fig 21-24. The internal salt concentrations were obtained by storing the specimens for 1/2 year in salt solution. Three different salt concentrations were used; 0%, 3% and 6%. Three different minimum freezing temperatures were used; -7°C, -14°C and -22°C. Two rates of freezing were used; "rapid" and "slow". The freeze/thaw cycles used are shown in Fig 25. The results indicate the existence of a pessimum external salt solution and this seems to be independent of the following factors: (i) the inner salt concentration; (ii) the rate of freezing; (iii) the lowest freezing temperature. In the actual study, the pessimum was 3%. It is, however, not possible to know, from these experiments, if 2%, or 4%, or any other concentration, had been "more pessimal".

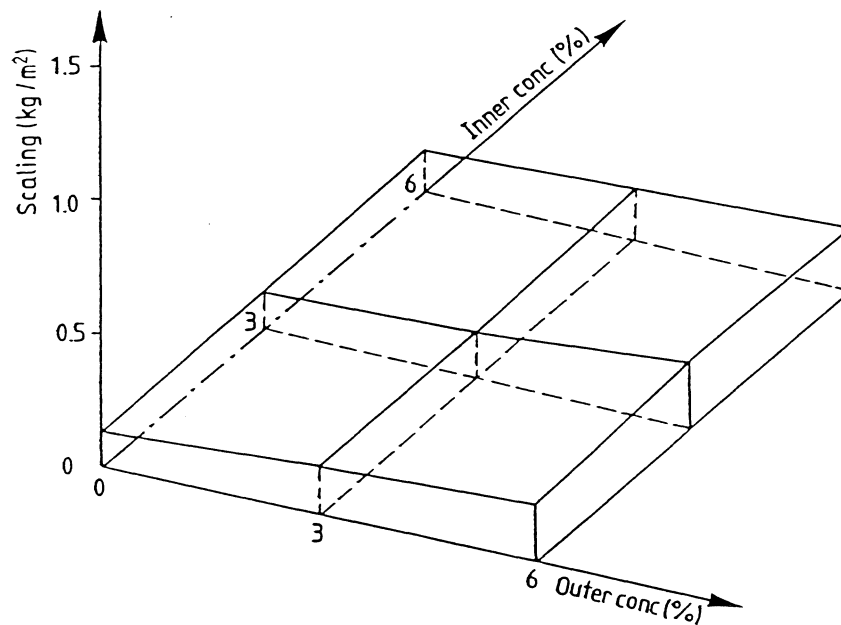

Fig 21: The total salt scaling after 56 freeze/thaw cycles of an air-entrained concrete with the water/cement ratio 0,40, tested with the minimum temperature -7°C and "rapid freezing", curve A in Fig 25; Lindmark [1993].

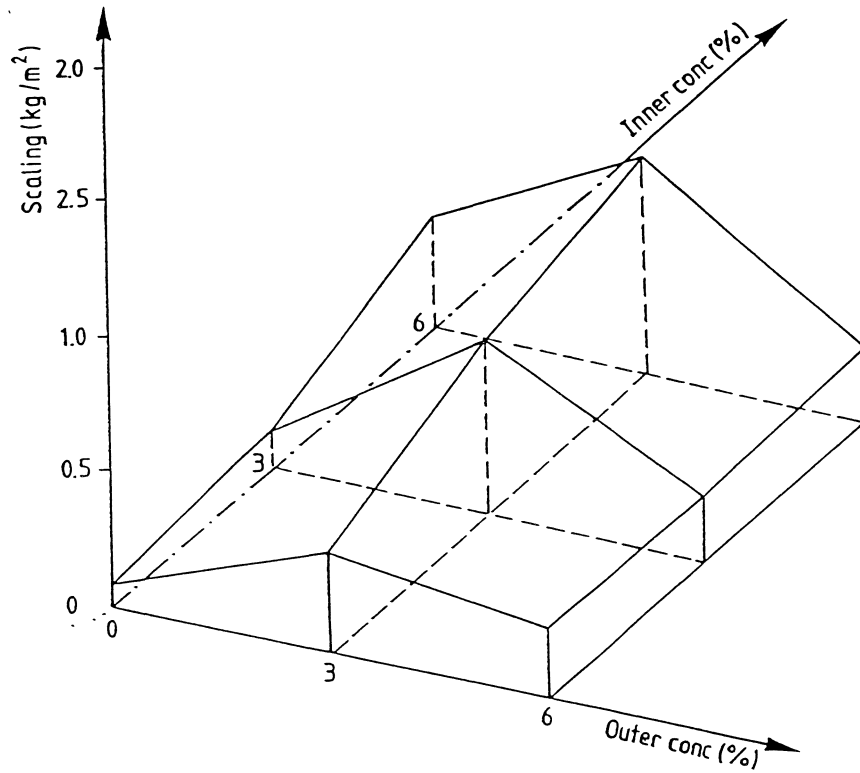

Fig 22: The total salt scaling after 56 freeze/thaw cycles of an air-entrained concrete with the water/cement ratio 0,40, tested with the minimum temperature -14°C and "rapid freezing", curve C in Fig 25; Lindmark [1993].

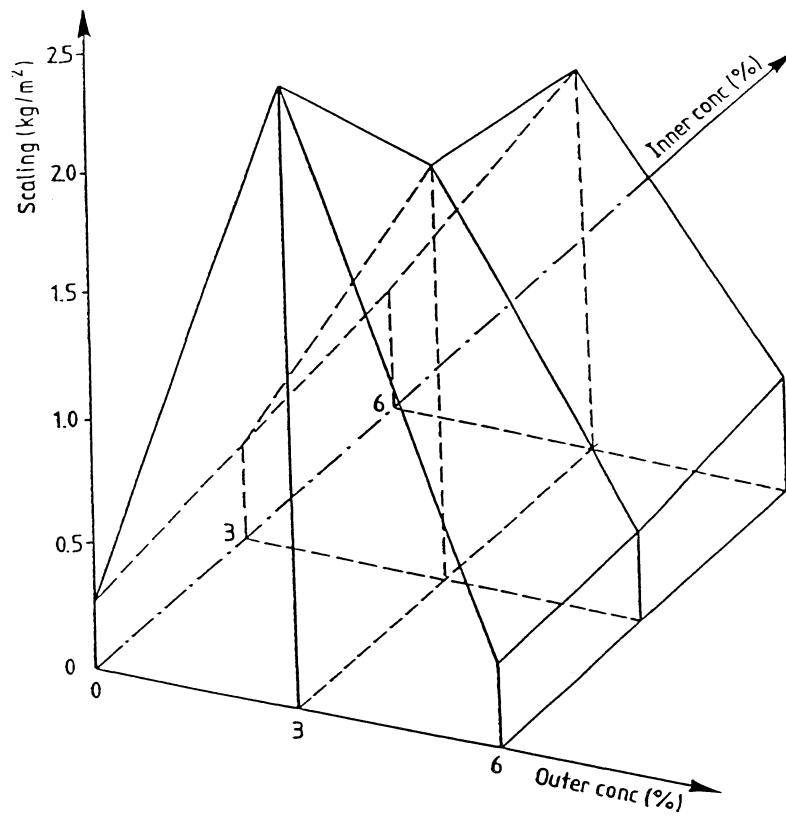

Fig 23: The total salt scaling after 56 freeze/thaw cycles of an air-entrained concrete with the water/cement ratio 0,40, tested with the minimum temperature -22°C and "rapid freezing", curve E in Fig 25; Lindmark [1993].

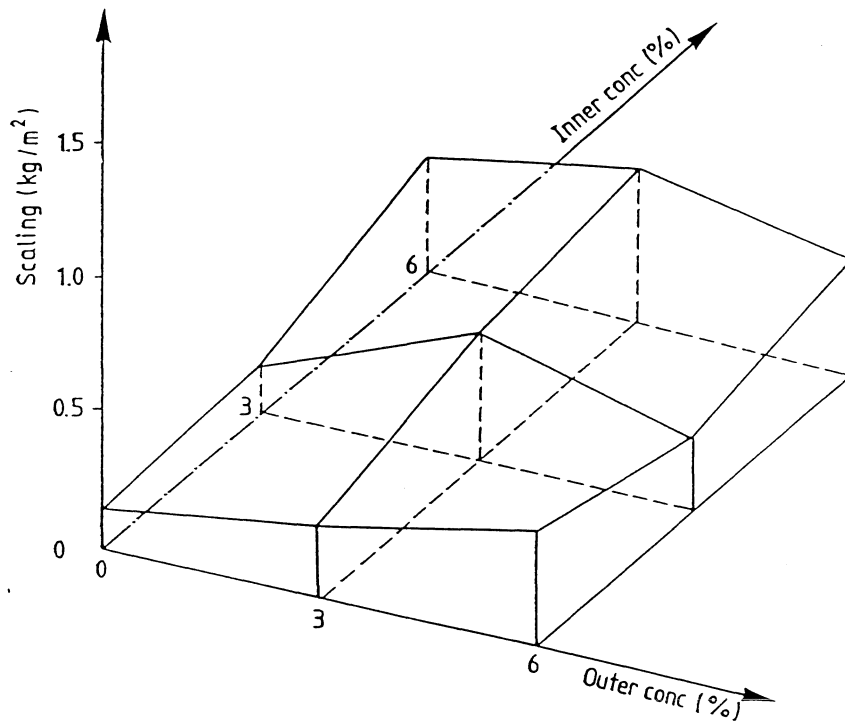

Fig 24: The total salt scaling after 56 freeze/thaw cycles of an air-entrained concrete with the water/cement ratio 0,40, tested with the minimum temperature -22°C and "slow freezing", curve F in Fig 25; Lindmark [1993].

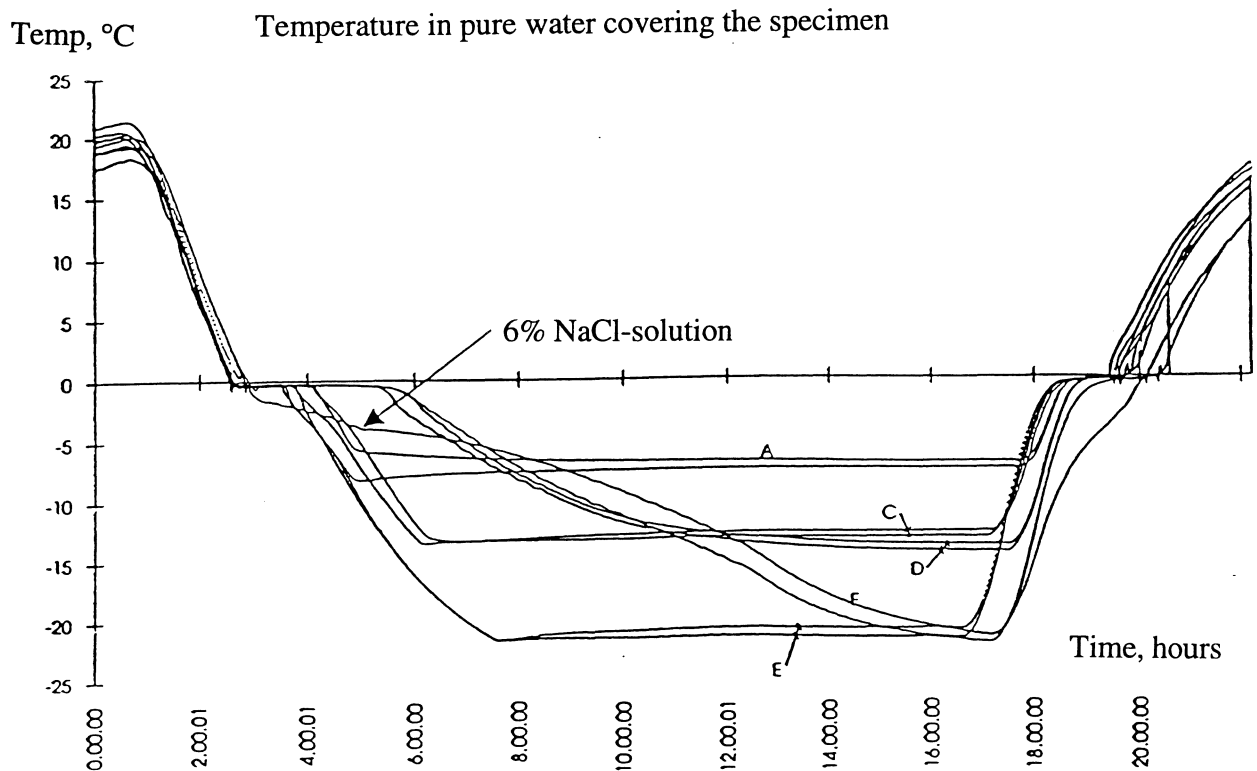

Fig 25: The freeze/thaw cycles used for the tests shown in Fig 21-24; Lindmark [1993].

The results are important, because they indicate, that an ageing of the concrete in the form of a gradual salt absorption in the pores, will not make the concrete more vulnerable to salt scaling; it is the *outer salt concentration* that counts. Similar observations to those in Fig 21-24 have been made by Sellevold [1990], and Sellevold and Farstad [1992].

The study also indicated, that the rate of freezing is of great importance; the more rapid the freezing, the bigger the scaling. It also showed, that the minimum freezing temperature is crucial; -7°C and -14°C being much less harmful than -22°C .

So far, the results presented in Fig 21-24, cannot be explained theoretically in a satisfying way. It is quite clear, however, that salt scaling is a very complex phenomenon, that involves moisture and salt migration before, during and after freezing, as well as internal pressure caused by many superimposed mechanisms.

Conclusion: Salt scaling is most severe at a certain pessimum *outer* salt concentration, and it is more severe the lower the temperature, and the more rapid the freezing. In reality, a concrete structure that is treated with de-icing salts, can be exposed to any salt concentration; from zero to saturated. A salt scaling test must therefore be designed in such a way, that the surrounding solution has the pessimum concentration, and in such a way, that the most severe freeze/thaw cycle occurring in practice is used.

6. The critical spacing factor

6.1 The critical Powers spacing factor

The two destruction mechanisms described in paragraph 4 predict the existence of a maximum possible distance between the place where water freezes and the nearest air-filled pore, that is big enough to take care of the water expelled from the surrounding freezing sites. The hydraulic pressure theory, as it is expressed in eq (11), immediately gives a value of the critical distance. It is obtained by putting the hydraulic pressure equal to the tensile strength of the cement paste:

$$f(X)_{CR} = f_t \cdot K / (0,09 \cdot dW_f/dt) \quad (14)$$

Where

- $f(X)_{CR}$ the maximum allowable (the critical) value of the function $f(X)$, describing the distance of the flow (m^2)
- f_t the tensile strength of the cement paste (Pa)

The function $f(X)$, describing the distance of the flow, depends on the geometry of the material that freezes. This, in turn, determines the "geometry of the water flow". The traditional geometrical model used is the Powers' model, according to which a cement paste shell with the thickness L_p is surrounding an air-pore with the specific area a . The shell has an impermeable outer periphery, so that all expelled water has to move towards the air-pore. This gives the following relation for $f(X)$:

$$f(X) = [L_p \cdot \alpha / 9 + 1/2] \cdot L_p^2 \quad (15)$$

Where

- L_p the Powers spacing factor (m)
- α the specific area of the central hole in the sphere (m^{-1}). [$\alpha = D/6$ where D is the diameter of the hole].

Thus, the critical spacing factor is defined by the expression:

$$L_{P,CR}^2 [L_{P,CR} \cdot \alpha / 9 + 1/2] = f_t \cdot K / (0,09 \cdot dW_f / dt) \quad (16)$$

The Powers spacing factor is based on a geometrical model in Fig 26, according to which all airpores are of the same size, and arranged in a cubic array; Powers [1949]. The size of the pores are such, that the specific area of every pore is the same as the specific area α_0 of the total air-pore system. The Powers spacing factor is based on all air-pores in the concrete. Also air-pores, that become water-filled in practice, are included in the definition of the spacing factor.

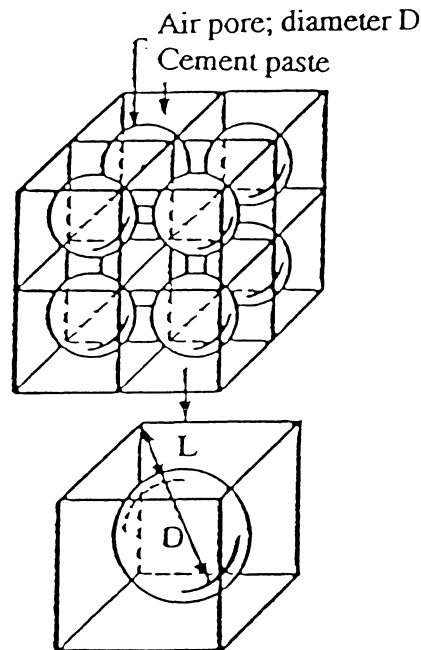

Fig 26: The geometrical model behind the Powers spacing factor; Cement paste cubes enclosing a spherical air-pore; Powers [1949].

The equation for a general spacing factor defined by the model in Fig 26 is:

$$L = \{1,4[V_p/a+1]^{1/3} - 1\} 3/\alpha \quad (17)$$

Where

- L the spacing factor (m). (The distance between the corner of the cement paste cube in Fig 26 and the periphery of the air-pore). L can either be the Powers spacing factor, in which all air-pores are included in a, or the true spacing factor, in which only the air-filled pores are included in a; see paragraph 7
- a the volume of the spherical holes in the model (m^3 or %)
- α the specific area of the spherical holes in the model (m^{-1})
- V_p the volume of the cement paste exclusive of the air-pores (m^3 or %)

The ice crystal growth mechanism also predicts the existence of a critical spacing factor. There is always some ice in the air-pores. This ice can grow without causing any stresses in the cement paste. Therefore, water migration to the air-pore ice will be promoted at the expense of migration towards saturated capillary pores. The shorter the average distance between air-pores, the larger the portion of water that moves towards the air-pore ice, and the smaller the internal pressure. At a certain spacing between air-pores, the stress is lower than that causing destruction. This is *the critical spacing*.

The critical Powers spacing factor is determined by comparing the result of a freeze/thaw test with the actual spacing factor. This is determined by the so-called linear traverse method, described in ASTM C457. The method can be either manual, or based on automatic image analysis. Examples of the relation between the result of a freeze test with pure water, and the Powers spacing factor, are seen in Fig 27 and Fig 28.

Fig 27 shows the expansion of cement pastes during freezing. The cement paste contracts when the spacing factor is below 0,012 inches or 0,30 mm. It expands when the spacing factor is 0,025 inches or 0,063 mm. The critical spacing factor, for the *actual type of test*, is somewhere between these two values. Powers' states that a critical spacing factor of 0,25 mm is on the safe side.

Fig 28 shows the durability factor determined by the test method ASTM C666 as function of the Powers spacing factor. There is a transition, from high frost resistance to low, at a spacing factor of about 0,22 à 0,25 mm.

In Fig 29, the expansion after 300 cycles of specimens frozen and thawed in air is plotted versus the Powers spacing factor. In this case, the critical value is considerably higher than in the other tests shown above. It varies between 0,45 mm and 0,63 mm depending on the rate of freezing.

The results show clearly, that no distinct value of the critical Powers spacing factor exists. Evidently, the exact value depends on the test method used.

The result of a *salt scaling test* in 3% NaCl-solution versus the Powers spacing factor is seen in Fig 30. In this case, the value is considerably lower than for freezing in pure water; the value 0,16 mm seems to define the limit between concrete with high salt scaling resistance, and concrete with low resistance. There are, however, concretes with a spacing factor as high as 0,23 mm, that are also salt scaling resistant.

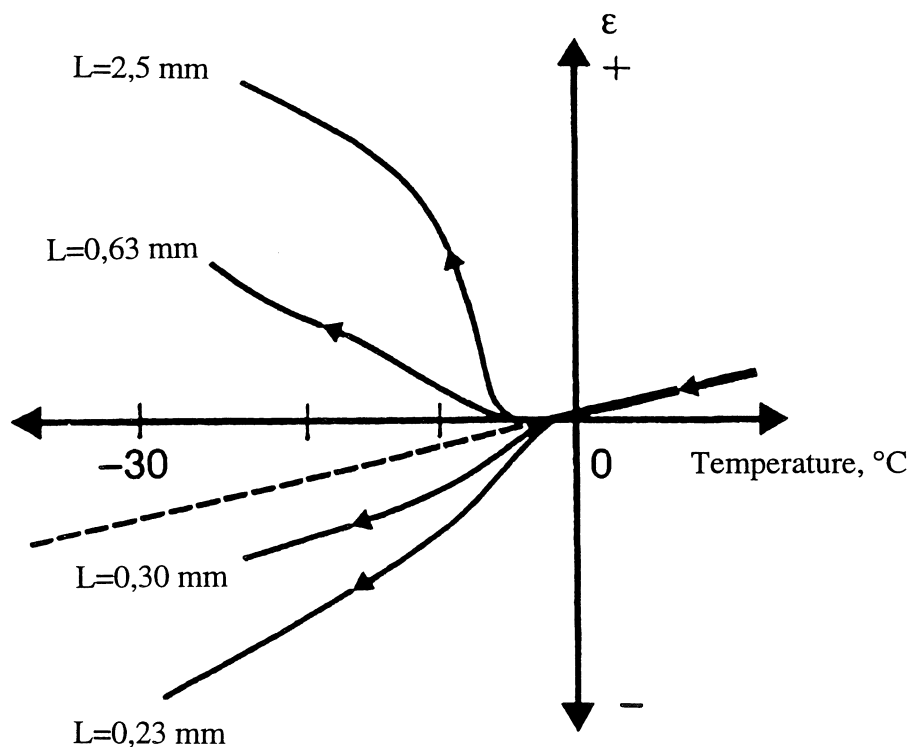

Fig 27: The length change during freezing of air-entrained portland cement pastes. The Powers spacing factor is different in different cement pastes with $w/c=0,60$; Powers and Helmuth [1953].

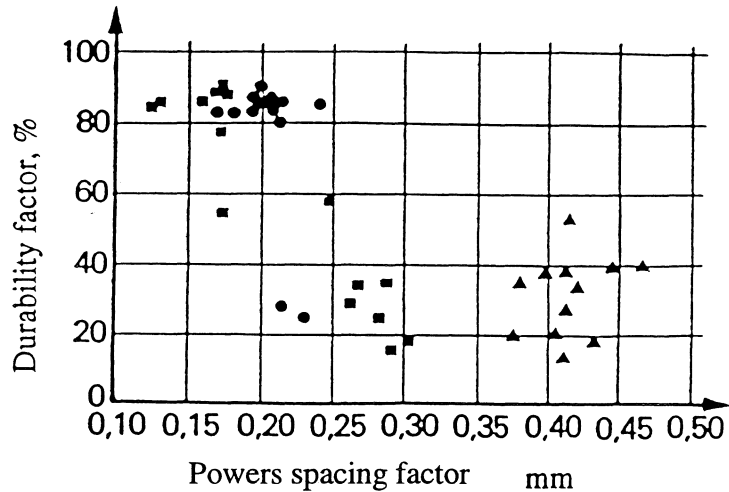

Fig 28: Relation between the "durability factor" and the Powers spacing factor of concretes tested in pure water; Ivey and Torrans [1970].

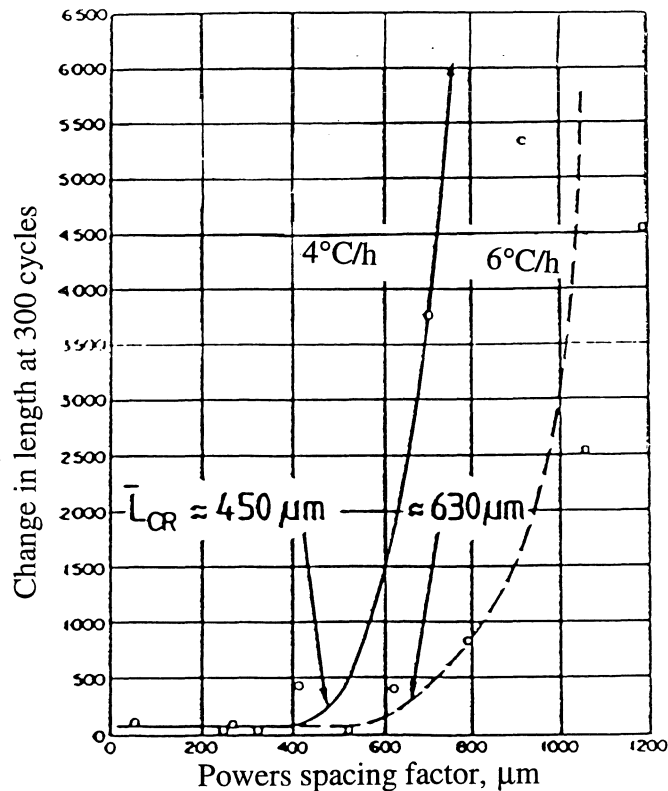

Fig 29: The expansion of a concrete after 300 freeze/thaw cycles in moist air. Two different freezing rates; Pigeon et al. [1985].

Another result of a salt scaling test is shown in Fig 31. In this case, the concrete is tested according to the German method, where concrete cubes are completely immersed in 3% NaCl-solution. The critical Powers spacing factor seems to be about 0,20 mm.

It is quite clear, that the critical Powers spacing factor is lower for salt scaling than for freezing in pure water. All the results presented above, and many more, indicate, however, that there are no exact and distinct values of the critical Powers spacing factor for freezing in pure water, or for salt scaling. *Therefore, it is also quite clear, that the Powers spacing factor cannot be used as a general criterion for frost resistance.*

The reason why the Powers spacing factor cannot be used is, that it neglects the water absorption in the air-pores; all air-pores are assumed to be available to water expelled from the freezing site. In reality, a large portion of the air-pores are water-filled, and should actually not be included in the calculation of the spacing factor. This is the most probable explanation why the critical Powers spacing factor is higher in the test shown in Fig 29, than in the test shown in Fig 28. In the first case, the test was rather "dry", since both the freezing and the thawing took place in air. In the other test, thawing took place in water, so that the air-pores could take up water. The implication of this is further treated in paragraph 7.

Conclusion: The existence of critical spacings between air-filled spaces is predicted theoretically by the two main destruction mechanisms, and most probably, they also exist in reality. In estimating their value, the water absorption in the air-pore system must be considered. The Powers spacing factor, as it is always used, assumes that all air-pores are actually air-filled. Therefore, it is not possible to find any distinct and general value of the critical Powers spacing factor. The more moist the environment, the lower the critical Powers spacing factor. Besides, the pore size distribution will affect the critical Powers spacing factor. The more fine-porous the air-pore system, the more rapid the water absorption, and the lower the critical spacing factor.

Thus, the critical Powers spacing factor is not a general material constant, but depends on the environment, and on the type of air-pores.

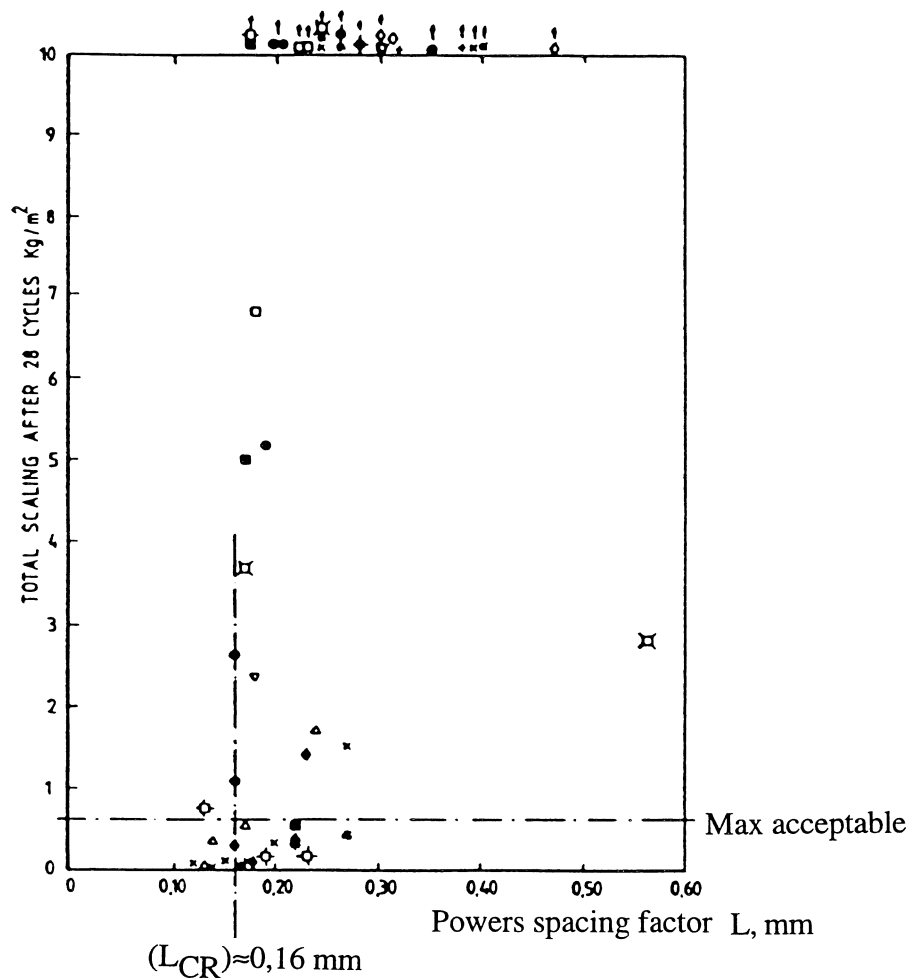

Fig 30: The relation between the salt scaling after 28 freeze/thaw cycles and the Powers spacing factor; Fagerlund [1988].

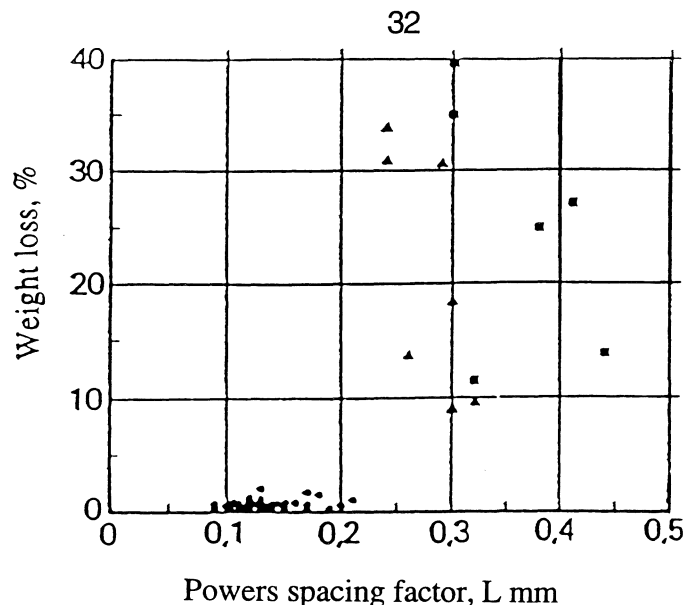

Fig 31: The relation between the Powers spacing factor and the weight loss of concrete tested according to the German method in 3% NaCl-solution; Bonzel and Siebel [1977].

6.2 The critical true spacing factor

In defining the *real* spacing factor, only air-pores that are actually air-filled should be regarded. The spacing between actually air-filled air-pores is called *the true spacing factor*. When determining the value of *the critical true spacing factor*, the result of a freeze/thaw test should be compared with the true spacing factor, in which the water absorption occurring in the air-pores during the test, is regarded. This means, that the critical true spacing factor is considerably higher than the critical Powers spacing factor. Besides, it is probably a material constant, that is independent of the outer moisture conditions.

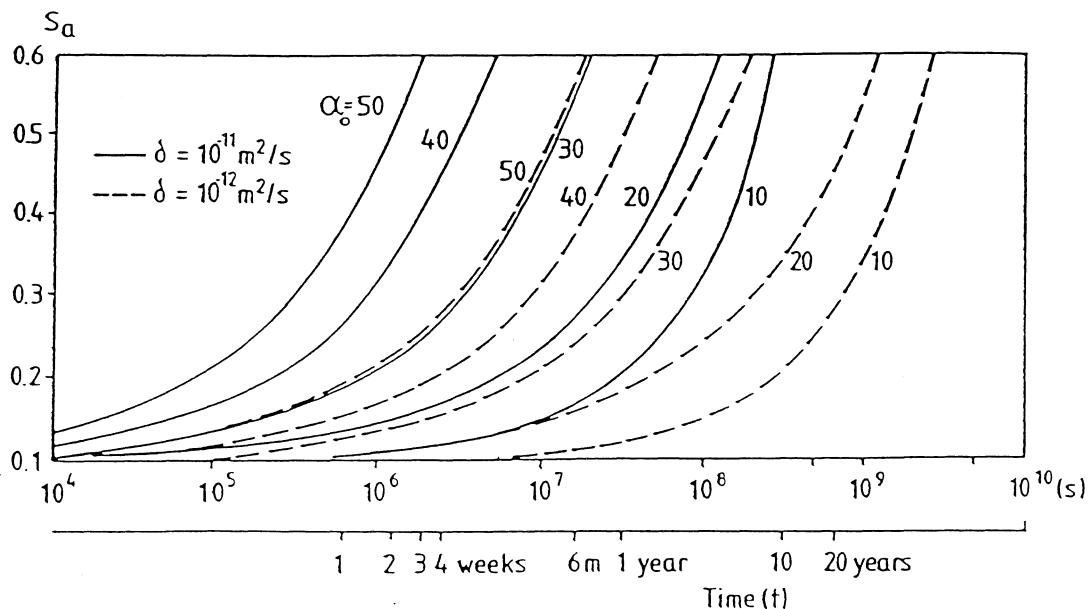

Fig 32: The theoretical water absorption in airpore systems that are described by eq (18) and with two different diffusivities of air diffusion, δ ; Fagerlund [1993A].

The water absorption in the air-pore system can be described by an equation of type eq (8). An example of a theoretical calculation of the degree of saturation of an air-pore system, described by the frequency function (18), is shown in Fig 32. The absorption rate depends on the fineness of the air-pore system, and on the diffusivity of dissolved air in the pore water.

$$f(r)=\ln b/b^r \quad (18)$$

Where

$f(r)$	the frequency function of air-pore radii
b	a coefficient, which depends on the fineness of the air-pore system
r	the air-pore radius (m)

As an example, the degree of saturation of the air-pore system, of concretes with the diffusivity $10^{-12} \text{ m}^2/\text{s}$, is calculated theoretically. See Table 3. The calculated absorption is substantial already after 1 month, which is a normal period for a freeze/thaw test. Another, purely experimental study, of the water absorption in air-pores is seen in Fig 12.

Table 3: Calculated degrees of saturation S_a of the air-pore system. Different water absorption times (t) and different specific areas of the air-pore system.

Specific area (mm^{-1})	Absorption time (days)	Degree of saturation of the air-pore system, S_a (%)
20 (coarse-porous)	7 (1 week)	2
	28 (1 month)	4
	365 (1 year)	15
30 (fine-porous)	7 (1 week)	5
	28 (1 month)	11
	365 (1 year)	40

The critical true spacing factor can be determined experimentally by a determination of the critical degree of saturation of the air-pore system, and a determination of the air-pore distribution. The calculation method is shown in Fagerlund [1979] and [1994A], and will now be described briefly.

The total air-pore volume, a_o , is:

$$a_o = \int_{r_{\min}}^{r_{\max}} f(r) \cdot (4\pi/3) \cdot r^3 \cdot dr \quad (19)$$

Where

a_o	the total air content (m^3)
$f(r)$	the frequency function of the air-pore radius
r_{\max}	the radius of the biggest air-pore
r_{\min}	the radius of the smallest air-pore

The critical degree of air-pore saturation corresponds to a certain volume of completely water-filled air-pores. This is given by:

$$(a_w)_{\text{CR}} = a_o \cdot (S_a)_{\text{CR}} \quad (20)$$

Where

a_w	the volume of completely water-filled airpores (m^3)
S_a	the critical degree of air-pore saturation
Index CR	"critical" or "maximum allowable"

But, $(a_w)_{CR}$ can also be written:

$$(a_w)_{CR} = \int_{r_{\min}}^{r_w} f(r) \cdot (4\pi/3) \cdot r^3 \cdot dr = a_o \cdot (S_a)_{CR} \quad (21)$$

Where, r_w is the radius of the biggest water-filled air-pore. In eq (21) it is assumed that a smaller air-pore is always water-filled before a bigger. By this equation, the radius r_w can be calculated, provided $(S_a)_{CR}$ and $f(r)$ are known.

The critical residual air-filled pore volume is:

$$a_{CR} = a_o - (a_w)_{CR} \quad (22)$$

Where

a_{CR} the residual air-pore volume of the air-filled portion of the air-pore system, when $S_a = (S_a)_{CR}$ (m^3)

Then, it is easy to calculate the specific area of the air-filled part of the air-pore system. It is:

$$\alpha_{CR} = \left\{ \int_{r_w}^{r_{\max}} f(r) \cdot 4\pi \cdot r^2 \cdot dr \right\} / a_{CR} \quad (23)$$

Where

α_{CR} the residual specific area of the air-pore system, when the water-filled portion is not included, and when $S_a = (S_a)_{CR}$ (m^2)

Now, the true critical spacing factor can be calculated by the Powers' equation [eq (17)], which is based on the geometrical model in Fig 26, but where only air-filled pores are regarded:

$$L_{CR} = \left\{ 1,4[V_p/a_{CR} + 1]^{1/3} - 1 \right\} 3/\alpha_{CR} \quad (24)$$

Where

L_{CR} the critical true spacing factor (m)

V_p the volume of cement paste exclusive of air-pores (m^3)

Evidently, it is rather complicated to determine the true critical spacing factor; both a freeze/thaw experiment, for determination of the critical air-pore absorption, and an experimental determination of the pore size distribution, are required. Some measurements have been made. They are collected in Fagerlund [1993B]. It seems as if the critical true spacing factor is about 0,33 à 0,35 mm for freezing with pure water in contact with the concrete. The value, therefore, is considerably bigger than the critical Powers spacing factor, which is of the order of size 0,25 mm; see paragraph 6.1.

The critical true spacing factor for salt scaling is not known. The fact, that the expansion is higher at a certain pessimum inner salt concentration, indicates that the critical true spacing factor is a bit smaller than for freezing in pure water; see Fig 18-20.

Conclusions: The fact that the air-pore structure absorbs water, and that this absorption is bigger the smaller the average pore size, implies that the true spacing factor, of actually air-filled air-pores, is considerably bigger than the Powers spacing factor, which is based on all air-

pores. Therefore, also the critical true spacing factor is bigger than the critical Powers spacing factor. Besides, in contrast to the critical Powers spacing factor, the critical true spacing factor ought to be constant and independent of the air-pore distribution, and of the outer moisture conditions.

Unfortunately, since it involves costly and complicated measurements, it is difficult to use the true critical spacing factor for quality control.

7. The required air content-theoretically

7.1 Based on the critical Powers spacing factor

The following geometrical relation is valid for the model in Fig 26. The equation was used above in another shape; eq (17).

$$a = V_p / \{0,364(L \cdot \alpha / 3 + 1)^3 - 1\} \quad (25)$$

Where

- a the required minimum air content (m^3 or %)
- α the specific area of the air-pores (the holes) in the model (m^{-1})
- L the spacing factor (m). (The distance between the corner of the cement paste cube in Fig 26 and the periphery of the air-pore). L can be either the Powers spacing factor, in which all air-pores are included in the value of a and α , or the true spacing factor, in which only the air-filled pores are included in the value of a and α .
- V_p the volume of the cement paste exclusive of the air-pores (m^3 or %)

The traditional way of calculating the air requirement is to use, in equation (25), the critical

Powers spacing factor, $L_{P,CR}$, and the total specific area a_0 of the whole air-pore system.

This is, however, a very dubious method; the critical Powers spacing factor is not very well defined, for reasons that were described in paragraph 6.1. Besides, one will obtain exactly the same air requirement, irrespective of the way in which the concrete is used. A concrete, which is stored continuously in water, will require the same amount of air, as if the same concrete was placed in a more dry environment. This depends on the basic assumption behind the Powers spacing factor; viz. that no air-pores can absorb water.

The errors in using eq (25), when the exact value of the critical Powers spacing factor is not known, can be shown by the following example:

A certain concrete has an air-pore system with the total specific area 25 mm^{-1} . The cement paste volume is 30%.

Case 1: The critical Powers spacing factor is 0,16 mm (Fig 30).
The air requirement is **8,3 %**.

Case 2: The critical Powers spacing factor is 0,20 mm (Fig 31).
The air requirement is **5,1 %**

Case 3: The critical Powers spacing factor is 0,25 mm (Fig 27).
The air requirement is **3,1 %**

A variation of 56 % in the critical spacing factor, causes a variation of more than 260 % in the required air content.

Conclusion: The critical Powers spacing factor cannot be used for calculating the required air content. The uncertainty in the value of the critical Powers spacing factor is simply too big. Besides, it is based on the theoretically wrong assumption, that air-pores stay air-filled.

7.2 Based on the true critical spacing factor

The required minimum amount of air-filled air-pores can be calculated by eq (25) by inserting the values of the critical *true* spacing factor and the specific area of the air-filled portion of the air-pore system. Then, consideration can also be taken to the wetness of the environment around the concrete. The required minimum total air content is the sum of the water-filled portion of the air-pore system and the air-filled portion:

$$a = a_w + a_{CR} \quad (26)$$

Where

- a the required total air content (m^3 or $\%$)
- a_w the water-filled portion of the air-pore system (m^3 or $\%$)
- a_{CR} the required minimum amount of air-filled pores (m^3 or $\%$)

It is wise to have a certain extra air content, or "air buffer", taking care of the case where the water absorption is higher in practice, than that anticipated. Therefore, the air requirement is:

$$a = a_w + a_{CR} + a_b \quad (27)$$

Where

- a_b the "air buffer" needed as an extra reserve (m^3 or $\%$)

Each environment corresponds to the absorption of a certain fraction of the air-pore system. This means, that after a certain time of water uptake, all pores smaller than r_w are filled with water. The residual specific area, when this occurs, is a_{CR} . It is calculated by eq (23) above. The required air-filled air-pore volume is a_{CR} and can be calculated by eq (25) expressed in the following way:

$$a_{CR} = V_p / \{0,364 [L_{CR} \cdot \alpha_{CR} / 3 + 1]^3 - 1\} \quad (28)$$

Where

- a_{CR} the required minimum content of *air-filled pores* (m^3 or $\%$)
- α_{CR} the specific area of the air-filled portion of the pore system (m^{-1})
- L_{CR} the critical true spacing factor (m).
- V_p the volume of the cement paste, exclusive of the air-pores (m^3 or $\%$)

The volume of water-filled pores is calculated by eq (21) above.

The theoretical calculation of the required air content can only be made when the air-pore distribution is known. The distribution curve is used, both for calculating the value of α_{CR} [eq (23)], and for calculating the value of a_w [eq (21) with $(a_w)_{CR} = a_w$].

The principles will be shown by some examples. The air buffer is neglected in the calculations. It might be reasonable to add about 1% of air to the calculated air contents.

(a) *Fine-porous air-pore system: $a_o=30 \text{ mm}^{-1}$.*

The air-pore distribution is described by eq (18). The specific area of the total air-pore system, 30 mm^{-1} , corresponds to $b=1,03$ in eq (18) when the pore radius is expressed in mm. The critical true spacing factor is supposed to be $0,35 \text{ mm}$. The volume of cement paste is 30%.

Case 1: *Rather dry environment.* All pores with diameter smaller than 140 mm are assumed to be water-filled. Thus $r_w=70 \text{ mm}$. Then, according to eq (23) $\alpha_{CR}=23 \text{ mm}^{-1}$. According to eq (21), the water-filled air-pore volume, a_w , is 16% of the total air-pore volume; i.e. $a_w/a_o=0,16$.

The required amount of air-filled pores is obtained by eq (28), after inserting the values $L_{CR}=0,35 \text{ mm}$ and $\alpha_{CR}=23 \text{ mm}^{-1}$. This gives $a_{CR}=1,8\%$

The minimum air content, therefore, is:

$$a_{\min}=0,16 \cdot a_{\min} + a_{CR}=0,16 \cdot a_{\min} + 1,8$$

$$a_{\min}=2,1\%$$

Case 2: *Medium wet environment:* All pores with diameter smaller than 200 mm are assumed to be water-filled. Thus $r_w=100 \text{ mm}$. Then, according to eq (23) $\alpha_{CR}=19,5 \text{ mm}^{-1}$. According to eq (21), the water-filled air-pore volume, a_w , is 34% of the total air-pore volume; i.e. $a_w/a_o=0,34$.

The required amount of air-filled pores is obtained by eq (28), after inserting the values $L_{CR}=0,35 \text{ mm}$ and $\alpha_{CR}=19,5 \text{ mm}^{-1}$. This gives $a_{CR}=2,6\%$

The minimum air content, therefore, is:

$$a_{\min}=0,34 \cdot a_{\min} + a_{CR}=0,34 \cdot a_{\min} + 2,6$$

$$a_{\min}=3,9\%$$

Case 3: *Very wet environment:* All pores with diameter smaller than 260 mm are assumed to be water-filled. Thus $r_w=130 \text{ mm}$. Then, according to eq (23) $\alpha_{CR}=17 \text{ mm}^{-1}$. According to eq (21), the water-filled air-pore volume, a_w , is 53% of the total air-pore volume; i.e. $a_w/a_o=0,53$.

The required amount of air-filled pores is obtained by eq (28), after inserting the values $L_{CR}=0,35 \text{ mm}$ and $\alpha_{CR}=17 \text{ mm}^{-1}$. This gives $a_{CR}=3,5\%$

The minimum air content, therefore, is:

$$a_{\min}=0,53 \cdot a_{\min} + a_{CR}=0,53 \cdot a_{\min} + 3,5$$

$$a_{\min}=7,4\%$$

(b) *Coarse-porous airpore system; $a_o=20 \text{ mm}^{-1}$.*

The air-pore distribution is described by eq (18). The specific area of the total air-pore system, 20 mm^{-1} , corresponds to $b=1,02$ in eq (18), when the pore radius is expressed in mm.

The critical true spacing factor, and the cement paste volume, are the same as in the previous example; $L_{CR}=0,35$ mm; $V_p=30\%$.

The three different environments in the previous example are assumed to correspond to the same radius r_w of the coarsest water-filled air-pore. The reason for this is, that the water absorption is determined mainly by the over-pressure in the air-bubbles enclosed in the air-pores, and this pressure is inversely proportional to the radius of the pore, and is not dependent of the pore volume.

Case 1: *Rather dry environment*: All pores with diameter smaller than 140 mm are assumed to be water-filled. Thus $r_w=70$ mm. Then, according to eq (23) $\alpha_{CR}=17,5$ mm⁻¹. According to eq (21), the water-filled air-pore volume, a_w , is 5% of the total air-pore volume; i.e. $a_w/a_0=0,05$.

The required amount of air-filled pores is obtained by eq (28), after inserting the values $L_{CR}=0,35$ mm and $\alpha_{CR}=17,5$ mm⁻¹. This gives $a_{CR}=3,3$ %

The minimum air content, therefore, is:

$$a_{\min}=0,05 \cdot a_{\min} + a_{CR}=0,05 \cdot a_{\min} + 3,3$$

$$a_{\min}=3,5 \%$$

Case 2: *Medium wet environment*: All pores with diameter smaller than 200 mm are assumed to be water-filled. Thus $r_w=100$ mm. Then, according to eq (23) $\alpha_{CR}=15,5$ mm⁻¹. According to eq (21), the water-filled air-pore volume, a_w , is 14% of the total air-pore volume; i.e. $a_w/a_0=0,14$.

The required amount of air-filled pores is obtained by eq (28), after inserting the values $L_{CR}=0,35$ mm and $\alpha_{CR}=15,5$ mm⁻¹. This gives $a_{CR}=4,2$ %

The minimum air content, therefore, is:

$$a_{\min}=0,14 \cdot a_{\min} + a_{CR}=0,14 \cdot a_{\min} + 4,2$$

$$a_{\min}=4,9 \%$$

Case 3: *Very wet environment*: All pores with diameter smaller than 260 mm are assumed to be water-filled. Thus $r_w=130$ mm. Then, according to eq (23) $\alpha_{CR}=14$ mm⁻¹. According to eq (21), the water-filled air-pore volume, a_w , is 26% of the total air-pore volume; i.e. $a_w/a_0=0,26$.

The required amount of air-filled pores is obtained by eq (28), after inserting the values $L_{CR}=0,35$ mm and $\alpha_{CR}=14$ mm⁻¹. This gives $a_{CR}=5,3$ %

The minimum air content, therefore, is:

$$a_{\min}=0,26 \cdot a_{\min} + a_{CR}=0,26 \cdot a_{\min} + 5,3$$

$$a_{\min}=7,1 \%$$

Those examples show, that the fine-porous air-pore system absorbs much more water than the coarse-porous. Therefore, the advantage of having a fine-porous air-pore system is not as big as predicted by the traditional method of calculating the air requirement, based on the critical

Powers spacing factor. In very wet environments, a fine-porous air-pore system is even a disadvantage; more air is needed in a fine-porous system. Therefore, the most interesting parameter for frost resistance seems *not to be the Powers' spacing factor, but the total air content.*

Conclusion: By utilizing the critical true spacing factor in calculating the air requirement, it is possible to consider different environments and their wetness. The use of the critical true spacing factor reduces significantly the importance of having a high specific area of the air-pore system, and it strengthens the importance of having a certain minimum air content. The required air content is more dependent of the wetness of the environment than of the fineness of the air-pore system.

Unfortunately, it is difficult to utilize the critical true spacing factor in practice, partly because its value is not very well-known -especially for salt scaling-, partly because our knowledge of the relation between the wetness of the environment, and the water absorption in the air-pore system, is inferior.

The theories presented in paragraphs 7.1 and 7.2 indicate that an indirect criterion for frost resistance shall preferably be based on the air content and not on the Powers spacing factor. A further discussion of the required air-content is performed in Fagerlund [1995].

8. The air content in practice

8.1 Principles

The frost resistance of a given concrete, in a given environment, increases with increasing air content of the hardened mix. This is a consequence of the existence of a critical true spacing factor. There is, however, no definite and general limit for the air content, above which concrete is always frost resistant, and below which, it is always non-resistant to frost. This depends on the fact that the air-pore system is different in different concretes, and on the fact that the air-pore system gradually becomes inactivated due to water absorption; c.f. paragraph 7.2. Therefore, principally, there are individual values of the critical air content for every concrete in every environment. Besides, the critical air content is different for freezing in pure water than for salt scaling. The latter is always higher. The reason for this is not known. Probably, however, the critical true spacing factor is lower for salt scaling, because the inner pressure is higher at a constant degree of saturation; see Fig 21-24. It is also quite possible that the air-pore system in the surface part of the concrete absorbs more water when the concrete is exposed to a salt solution at its surface; a qualitative discussion of this interaction between salt and water is made in Fagerlund [1994A].

It is quite clear, however, that there is a general trend, that the frost resistance of concrete increases with increasing air content of the fresh mix. This, in turn, determines the air content of the hardened mix. An example of this is shown in Fig 33. All concretes were tested in pure water, according to a test method that is similar to ASTM C666. There is a transgression zone between 1,5% and 3% of air, within which there are both durable and undurable concretes. Below 1,5%, no concretes are frost resistant. Above 3%, all concretes have a high frost resistance. This transition zone reflects the fact that the pore size distribution is not constant, but varies from concrete to concrete. This is also shown by Fig 34, where the relation between the Powers spacing factor and the air content is plotted for a large number of concretes. There is by no means any well-defined relation.

For a high salt scaling resistance, considerably more air is normally needed, than for freezing in pure water. This is shown by Fig 35, where the relation between the salt scaling according to a method that is similar to the Swedish standard method SS 13 72 44 ¹, and the air content of the hardened and the fresh concrete, is plotted for a large number of specimens, containing

¹) Except for, that no heat insulation of the specimen was used.

many different air-entraining admixtures, and many different water reducing agents. There are concretes with very high air contents (>8%), that are completely destroyed after 28 freeze/thaw cycles, whereas there are other concretes with low scaling, despite the air content is only 3%.

If only such concretes, that contain an air-entraining agent of type neutralized Vinsol Resin, but no water reducing agent (or superplasticizing agent), are considered, there is a much more well-defined relation; see Fig 36, where the scaling is plotted versus the air content determined after different types of compaction of the concrete before the air-measurement. Now a critical air content can be identified. It is about 5,5% when the concrete is table vibrated (air content a_1), and 4,5% when it is compacted by poker vibration (air content a_2).

Conclusion: The frost resistance, and the salt scaling resistance, increase with increasing air content of the fresh and the hardened concrete. No general value exists, that can be used for all concretes, concerning the minimum air content. Instead, the minimum air content is individual for each concrete, and is determined by the air-pore characteristics, and other characteristics of the actual concrete. The air-pore characteristics are mainly determined by the admixtures used, and of their interaction with the pore solution of the fresh mix; i.e. the chemical characteristics of the cement. The only way to determine the minimum air content is to make freeze/thaw tests with the concrete containing different air contents. Concretes with high durability at the lowest possible air content shall be sought.

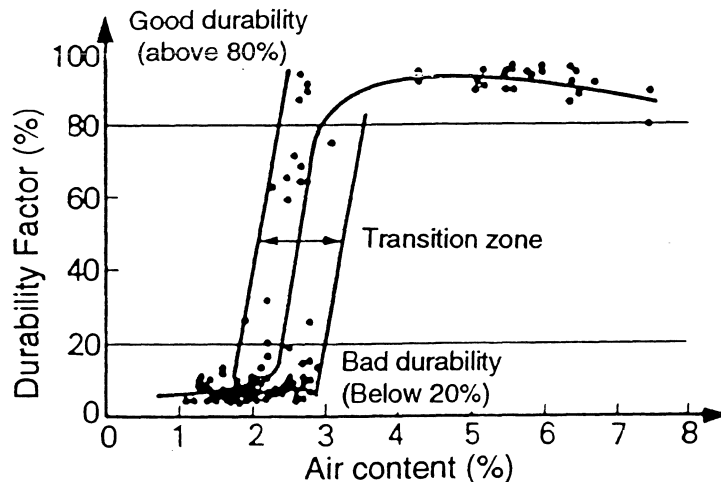

Fig 33: Relation between the air content and the durability factor of concrete tested in pure water; Cordon [1966].

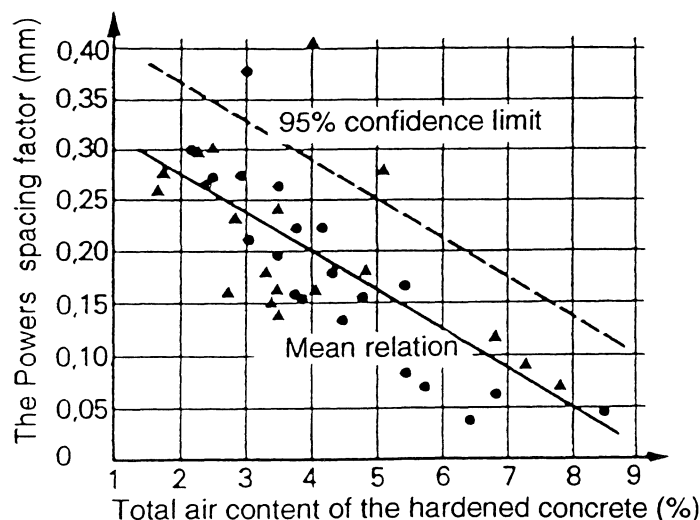

Fig 34: Relation between the air content of the hardened concrete and the Powers' spacing factor for a large number of concretes; Amsler and Eucker [1973].

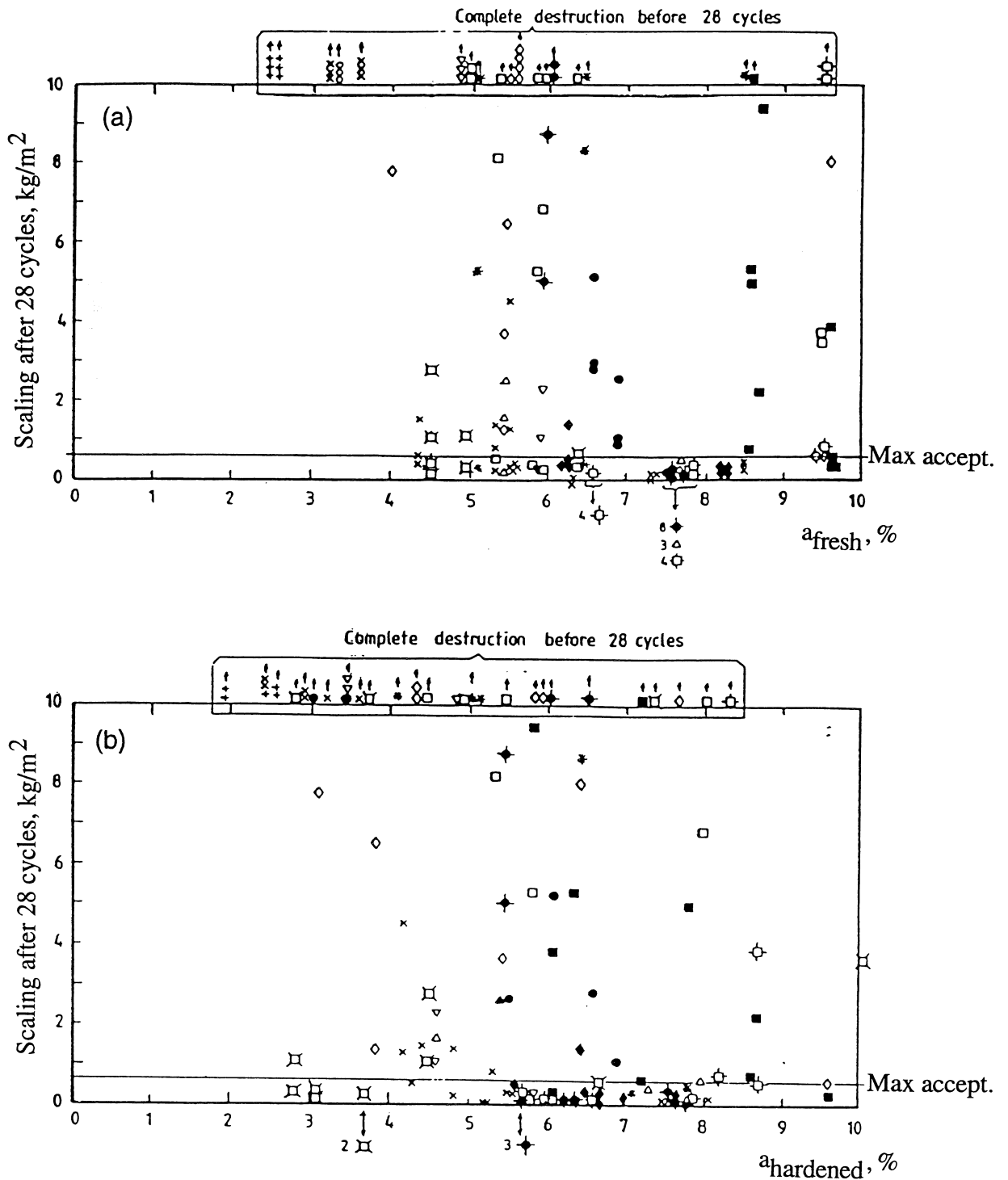

Fig 35: Relation between the salt scaling after 28 freeze/thaw cycles and the air content of the fresh concrete. A large amount of different air-entraining admixtures and water reducing agents were used. Constant water/cement ratio, 0,45. (a) The scaling versus the air content of the fresh concrete. (b) The scaling versus the air content of the hardened concrete; Fagerlund [1988].

8.2 Air in fresh concrete versus air in hardened concrete

The durability is determined by the air content of the hardened concrete. For practical reasons it is, however, necessary to base the production of the concrete, and the quality control of frost resistance, mainly on the air content of the fresh concrete. There is always a certain difference between the two air contents; the "fresh air content" normally being higher. Examples of this are seen in Fig 36, showing the freeze/thaw results for concretes with the same air-entraining admixture, and the same cement. The air content a_1 is determined by the Swedish standard method, according to which the concrete in the air-measurement vessel is table vibrated. The air content a_2 is determined after poker vibration of the concrete in the vessel, and the air content a_4 is determined on a sample, that has first been excavated from a bigger poker-vibrated concrete volume (≈ 100 litres), and which has then been, once again, compacted by poker vibration in the air-measurement vessel. The three air contents differ by 1% in air content, the poker-vibration of the vessel being the most "aggressive" treatment, and the Swedish Standard method being the mildest.

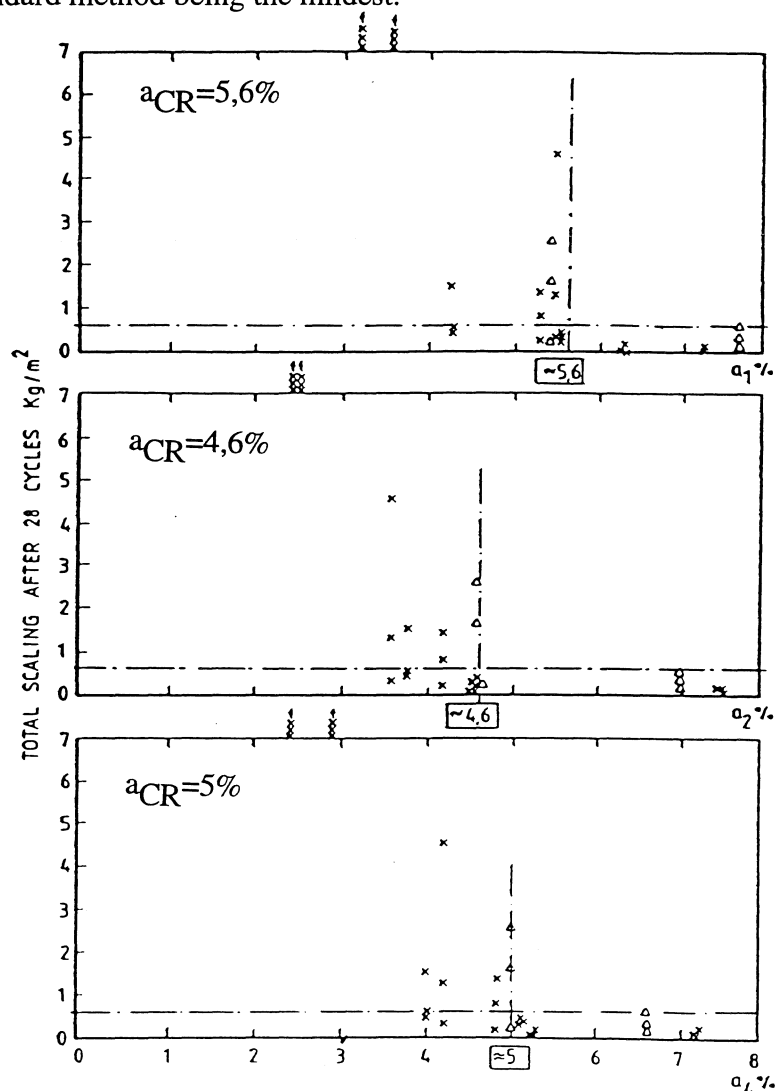

Fig 36: Data from Fig 35 but only concretes with one single air-entraining agent (neutralized Vinsol Resin) and without water reducing agents; Fagerlund [1988].

The results in Fig 35 show rather small variations in the air content. With other air-entraining admixtures, the deviations are much bigger. One example is seen in Fig 37, where the results from some water reduced and super-plasticized concretes are shown; [18]. The difference between poker vibration and table vibration is often very big. Probably, the air content in the real structure resembles the poker-vibrated air content, more than the table-vibrated.

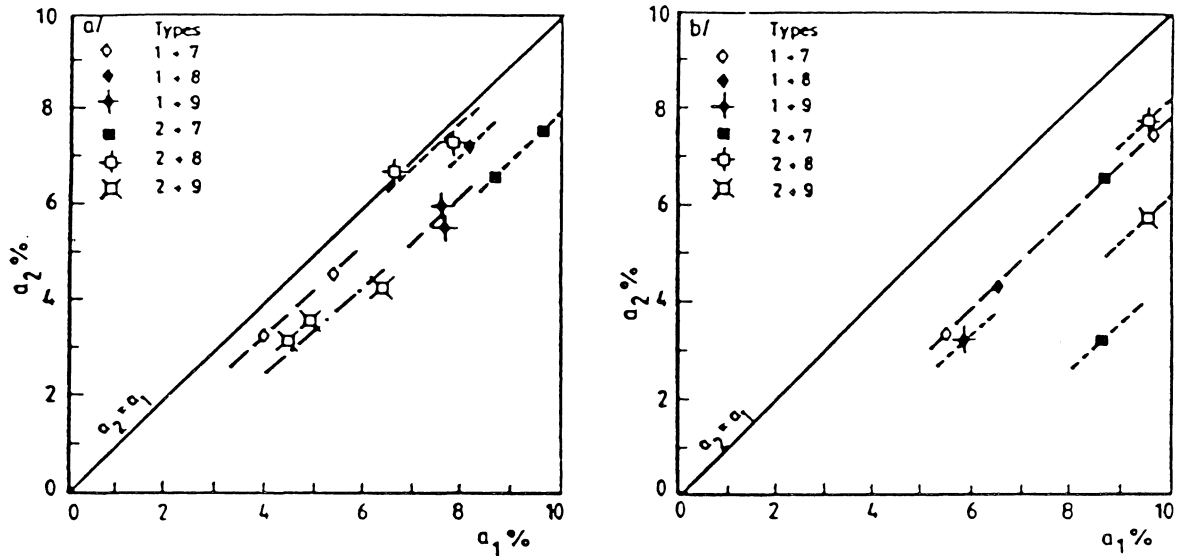

Fig 37: Relation between the air content of the fresh concrete determined in two different ways; by poker-vibration (a_2) and by table vibration (a_1) of the air-measurement vessel; Fagerlund [1988]. (a) Pure air-entraining agents. (b) Combined air-entraining and water reducing agents. (1 and 2 are two types of air-entraining agents; 7, 8 and 9 are three types of super-plasticizing agents combined with the air-entrainers.)

It is clear, that the compaction of the air-measurement vessel must represent the real structure, if it shall be possible to use the air content of the fresh mix for production control. It is also important, that the air content of the concrete, that is used for freeze/thaw specimens, is determined in the same way as the air content used for production control. Such freeze/thaw specimens are used in pre-testing, for establishing the recipe of the concrete to be used in the structure, and, sometimes, in production testing, for controlling the level of the frost resistance.

Conclusions: In establishing the minimum air content needed for a high frost and salt scaling resistance, it is important to select a compaction method that as closely as possible represents the compaction and the air content of the concrete in the structure. Besides, the concrete for which the measurement of the air content is made, shall have undergone a representative treatment as regards mixing, transport, and placing (e.g. pumping).

9. Effect of different concrete technology factors

9.1 Portland cement

The type of Portland cement is of big importance for the possibility of producing a concrete with high frost resistance. In Fig 38 is shown a comparison of the salt scaling resistance of concrete produced with 5 Swedish cements. All cements were used in concretes with different types of air-entraining and water reducing admixtures. The air content of the fresh concrete was $6 \pm 0,5\%$ in all concretes. 3 specimens of each batch were tested. Only one cement was able to produce concrete with high and safe salt scaling resistance, and small spread in the result. The other 4 cements produced concretes with low, or average, salt scaling resistance, and with big spread in the results. The cement with good performance ("A-cem") was of low alkali type (0,5%), and low C_3A -content ($<2\%$). All the other cements were high alkali ($\approx 1\%$), and had high C_3A -content ($\approx 8\%$).

In Fig 39, another comparison is made between two of the cements from Fig 38. In this case, the air content was varied, and two types of air-entraining admixtures were used (C88L and

AerL). The cement of type "Degerh" (the same as "A-cem" in Fig 38), which is low alkali and low C_3A , was able to produce concrete with high salt scaling resistance with air contents that are as low as 4%. The cement of type "Slite", which is high alkali and high C_3A , produced concrete that require 5,5-6% of air in order to obtain an acceptable salt scaling resistance.

Thus, it seems as if the chemical properties of the portland cement plays a fundamental rôle for the salt scaling resistance. This is most probably an effect of the airpore structure, that is produced. It was shown already by Mielentz et al [1958] that an increased alkali content produced a more coarse air-pore structure. This has also been verified by Pistilli [1983]; see Fig 40. He found that, the higher the solved alkali content in the pore water, the bigger the Powers' spacing factor.

Conclusion: The selection of the Portland cement is a crucial factor. It is necessary to select a cement which is able to produce a high frost resistance with as low air content as possible. This selection must be based on pre-tests of the frost and salt scaling resistance.

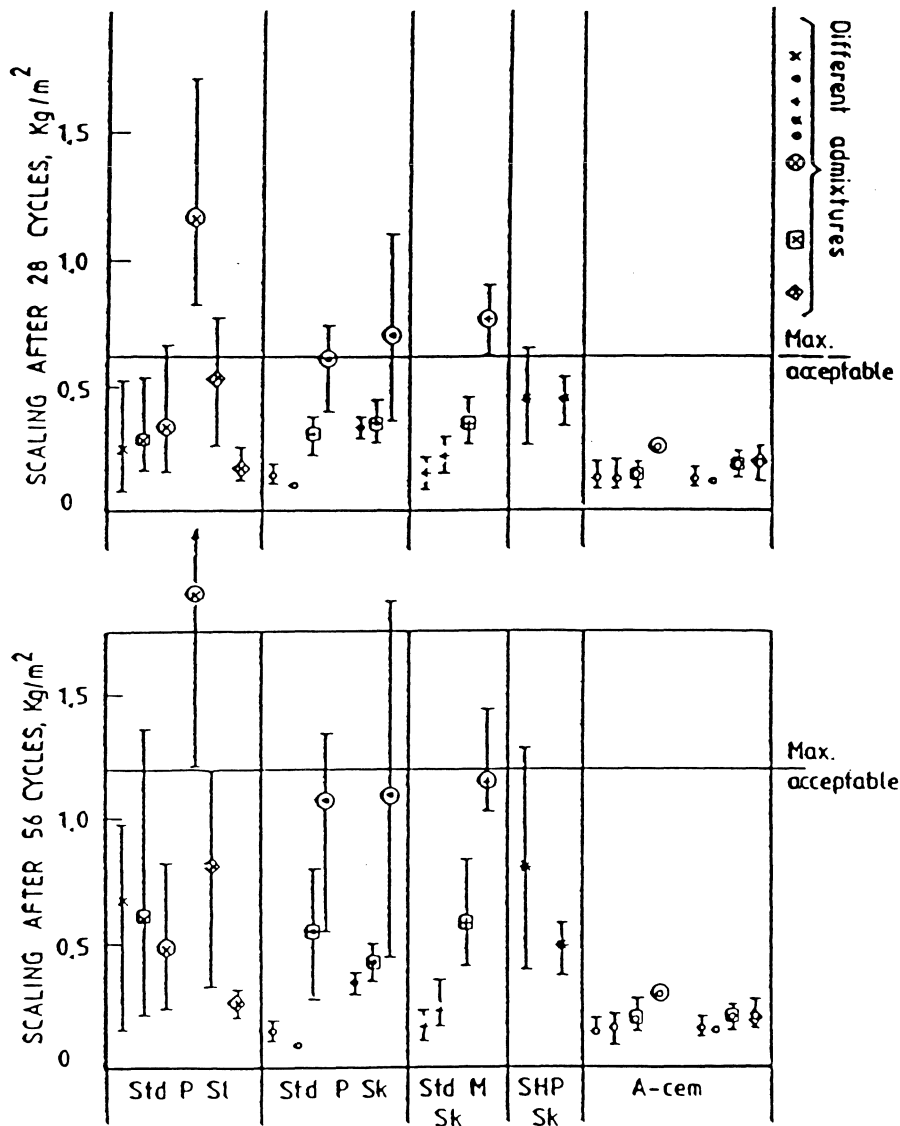

Fig 38: The salt scaling resistance of concrete made with 5 types of cement and with different types of air-entraining and water reducing admixtures. The "fresh" air content is about 6% in all concretes; Fagerlund [1988].

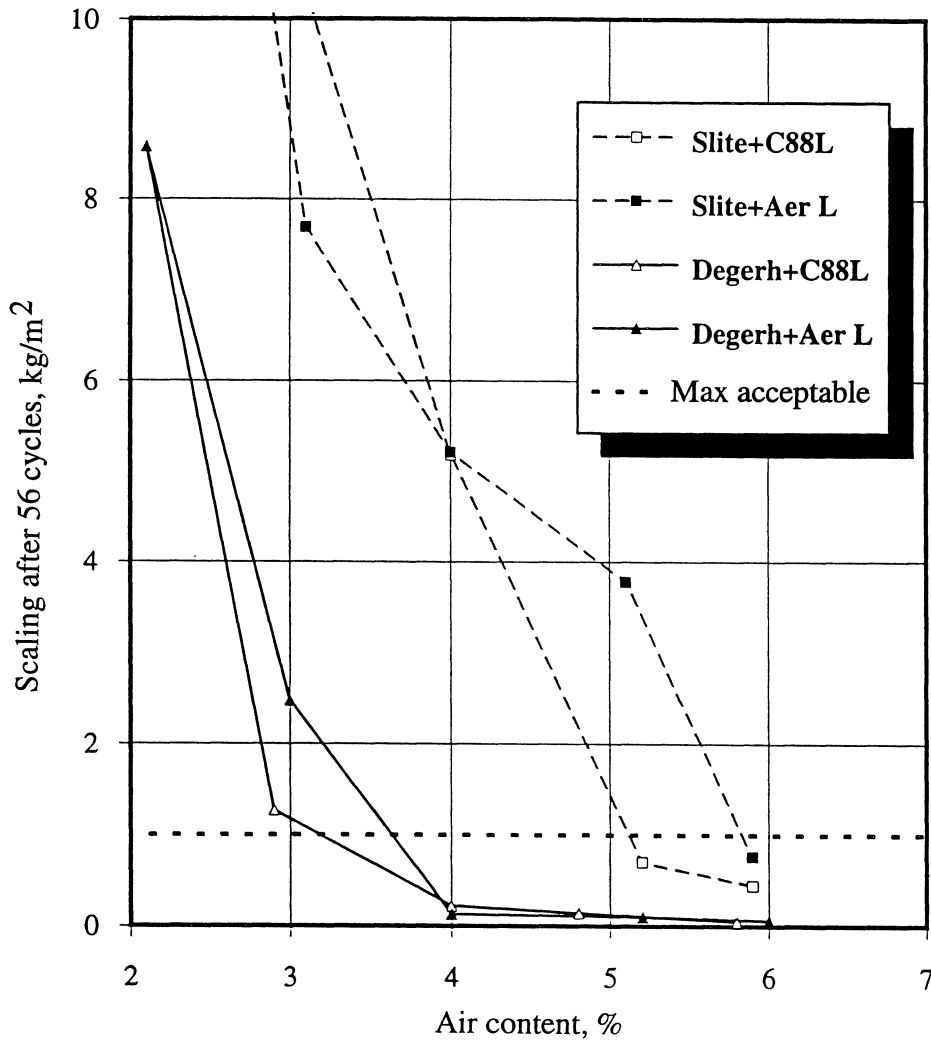

Fig 39: The effect of the "fresh" air content on the salt scaling of concrete made with two types of cement ("Slite" and "Degerh" and 2 types of air-entraining admixtures (C88L and Aer L); Malmström [1990].

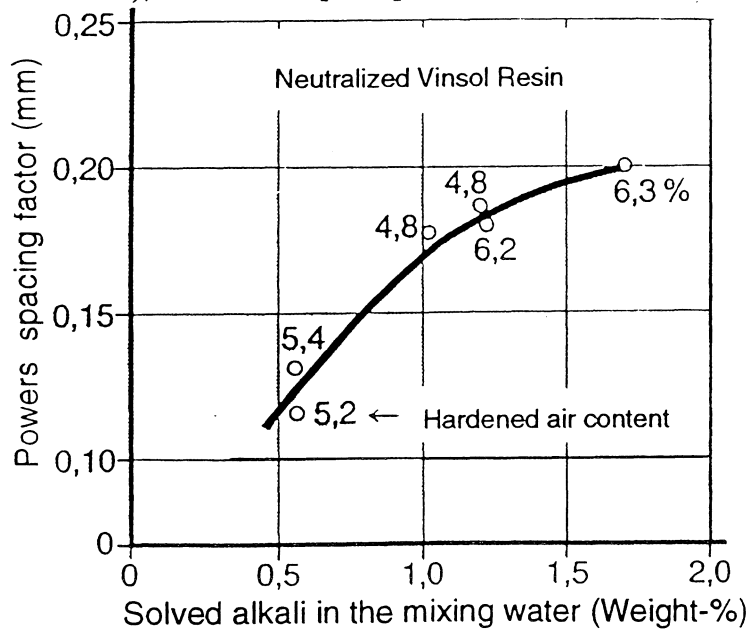

Fig 40: The effect of the dissolved alkali in the pore water in the fresh concrete on the Powers' spacing factor; Pistilli [1983].

9.2 Mineral admixtures

The mineral admixtures, that are of interest, are

- * Fly ash from coal burning
- * Silica fume (or "Microsilica")
- * Ground granulated blast furnace slag

All these admixtures have an influence on the frost and salt scaling resistance.

Fly ash

In a short term freeze/thaw test, the salt scaling of concrete containing fly ash is often just as high as of concrete containing the pure Portland cement, under the condition that the air content is the same; Fig 41 (b). On the other hand, if the concrete contains no air-entraining admixture, the frost resistance of concrete, containing also a very small amount of fly ash, might be very low. One example is seen in Fig 41 (a). Other examples can be found in Osborn and Rixom [1981]. The most plausible reason is, that the presence of fly ash reduces the natural air content to a very low value. In a normal concrete, it is 1,5 to 2,5%. In fly ash concrete, often it is only 1%, or less.

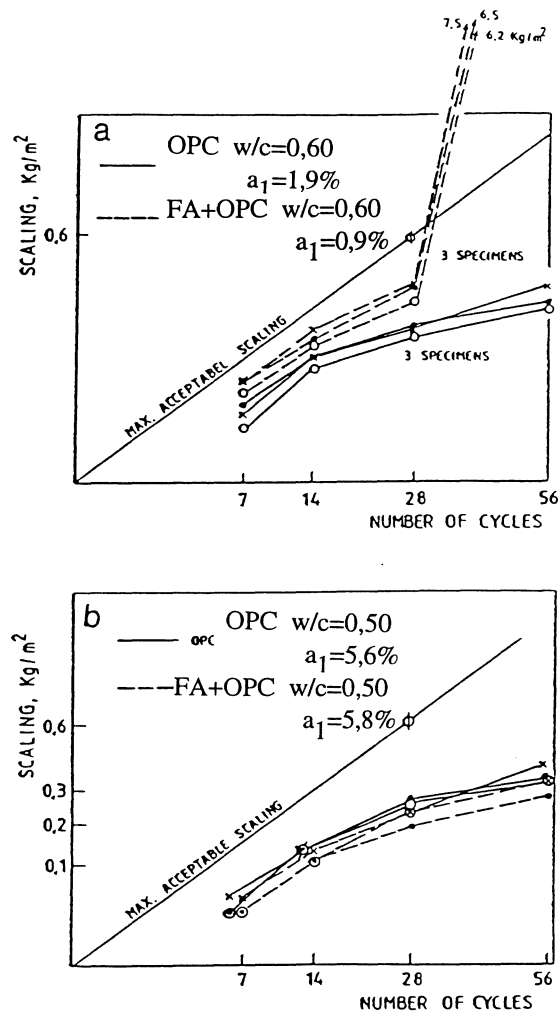

Fig 41: Effect of the addition of 5% of fly ash (counted on the portland cement) on: (a) the frost resistance in pure water; (b) the salt scaling resistance of concrete. In (a) the concretes have no extra air-entrainment, in (b) they have about 6% of air; Fagerlund [1988]. (a_1 is the air content of the fresh mix.)

There are, however, also some negative effects caused by fly ash. The first effect to consider is an increased variation in the air content of the fresh mix. Small variations in the loss on ignition of the ash, and in the so-called "organic content", cause large variations in the required dosage of the air-entraining admixture. One example is seen in Fig 42. Therefore, if this is not considered, the variation in the air content of the fresh mix, and thus the variation in the frost resistance, will be higher than can be accepted. The fly ash to be used in concretes with high frost resistance, therefore, must be of an exceptional high quality, with small variations in the loss on ignition and "organic content". The control of the air content must also be very strict, and concrete batches with too low air content must be rejected.

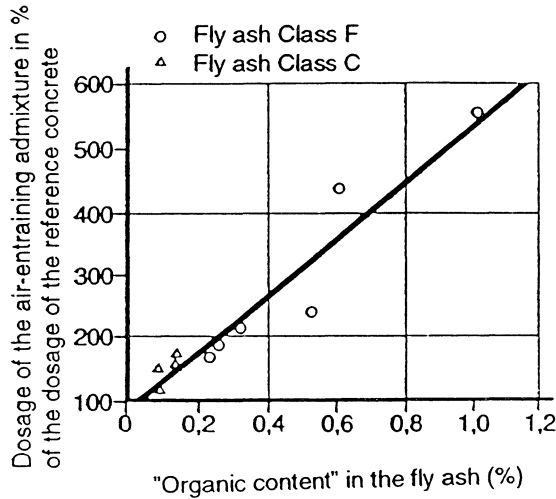

Fig 42: Effect of the "organic content" of fly ash on the air content of the concrete; Gebler and Klieger [1983].

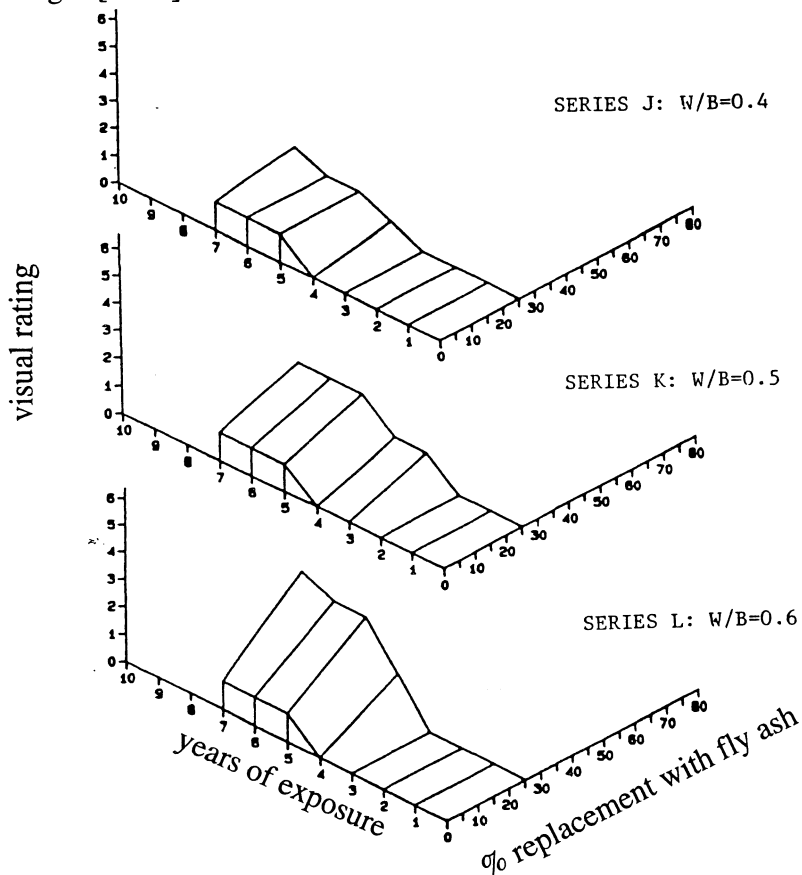

Fig 43: Result of exposure tests at Treat Island in Canada on the long-term behaviour of air-entrained concrete containing fly ash; Bremner et al [1989].

A possible, second, negative effect, is a bad long-term performance. This was found in a big study at Treat Island in Canada, where concrete containing different amount of fly ash, slag and silica fume were exposed to natural weathering by tidal Atlant water and freeze/thaw. Some results are shown in Fig 43 for concretes with high air content. The general trend is, that an increased amount of fly ash impair the long term behaviour.

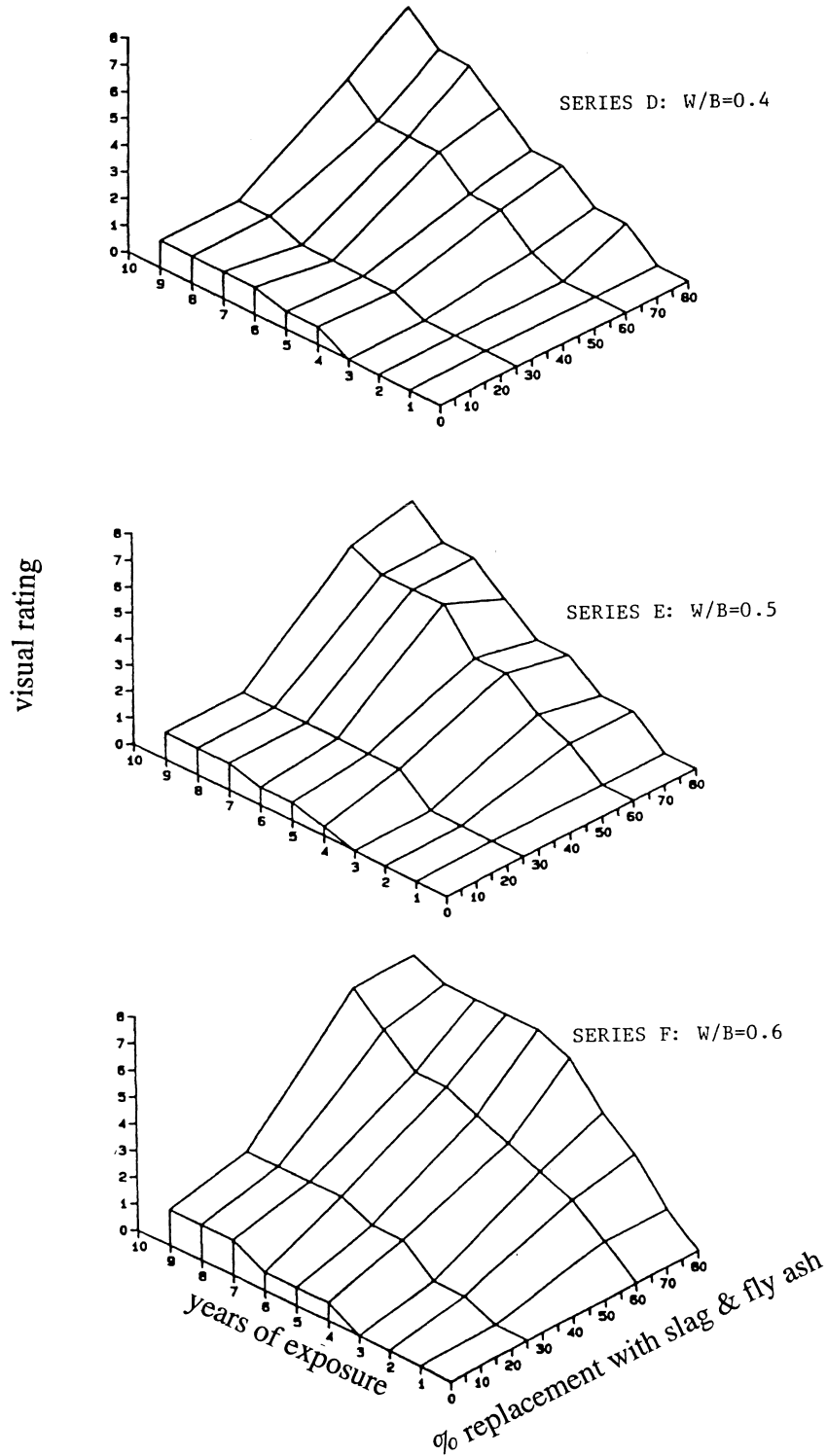

Fig 44: Result of exposure tests at Treat Island in Canada on the long-term behaviour of air-entrained concrete containing a combination of fly ash and blast furnace slag; Bremner et al [1989].

Another example from the Treat Island investigation is shown in Fig 44. The fly ash was mixed with slag. The negative effect on the long term behaviour is obvious. The frost resistance after a short time of exposure is, however, about the same for all concretes.

The reason behind this behaviour can be twofold, (i) concrete containing large amounts of fly ash, and/or slag, has a reduced possibility of self healing cracks and other defects, that appear during the long-term exposure; (ii) the air-pore system is more rapidly filled by water during long-term exposure to water, either because the diffusivity of dissolved air from the air-pores is bigger, or because the air-pore system is more fine-porous; Fig 12.

Silica fume

Silica fume is normally used in quantities not exceeding 10% of the cement weight, and often only 5%. Therefore, its effect on the frost resistance seems to be marginal, provided the air content is maintained on a level, that is high enough. Besides, the long-term tests at Treat Island indicate, that a negative effect occurs only when the amount of silica fume exceeds 10%; see Fig 45.

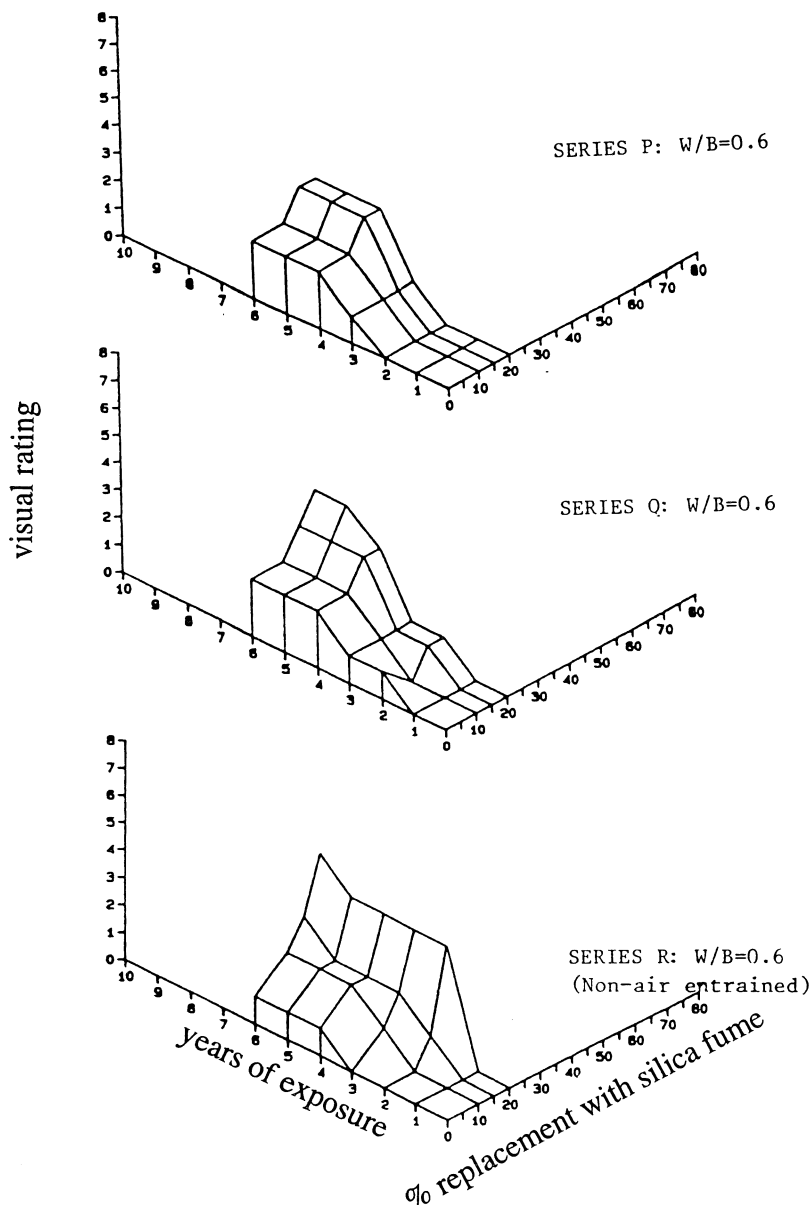

Fig 45: Result of exposure tests at Treat Island in Canada on the long-term behaviour of air-entrained concrete containing silica fume; Bremner et al [1989].

In Fig 8, it is shown, that the salt scaling in a standard test of concrete containing silica fume, might become accelerated after some time. This behaviour has not been explained. One possibility is, that the air-pore structure in concrete with silica fume is so fine, that the water uptake in the air-pores becomes very rapid. Therefore, the critical degree of saturation is reached after a shorter time than what occurs in a concrete without silica fume. It must also be noted, that the concretes in Fig 8 contained an unacceptable large portion of silica fume ; 11% and 19%.

Ground granulated blast furnace slag

It is doubtful whether a concrete containing slag will ever obtain the same good frost resistance as concrete containing the pure portland cement with which the slag cement is mixed. It might be that the short-term durability is the same, but it seems as if the ageing properties of slag cement concretes are rather bad. This was observed in a study in Finland where concretes containing different types of binders were first frost tested in the virgin state. Then, they were exposed to two types of natural ageing, and were frost tested once again. In the virgin state, the slag cement behaved just as well as the portland cement or even better. After ageing, the salt scaling resistance of the slag cement concretes was deteriorated. The pure Portland cement concrete, on the other hand, was improved or unchanged after the ageing; see Fig 46.

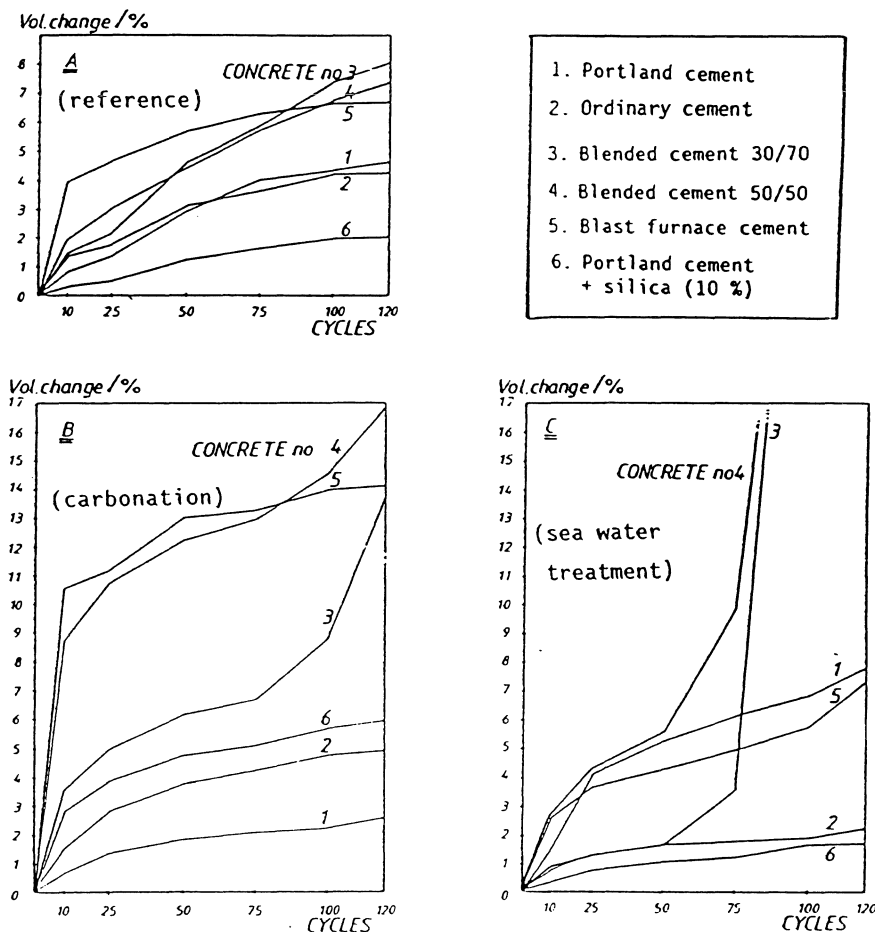

Fig 46: The effect of natural ageing on the salt scaling resistance of concrete containing different types of mineral admixtures or pure portland cement; (A) before outdoor exposure, (B) after 200 days of exposure to 70% RH, (C) after 30 cycles of exposure to sea water and drying (each cycle is 7 days); Vesikari [1988]. (The "ordinary cement" contains 17% fly ash and 6% blast furnace slag; The "blended cement 30/70" contains 30% blast furnace slag; The "blended cement 50/50" contains 50% blast furnace slag; The "blast furnace cement" contains 70% blast furnace slag; The "silica (10%)" is 10% silica fume in the mix.)

A similar, negative, long-term behaviour of slag cement concretes was observed in the Treat Island test. This is shown by Fig 44, where the slag is mixed with fly ash, but also by Fig 47, where the slag is used alone. The larger the slag content, the lower the durability. Slag cements are always used with high slag contents due to the necessity of having a high sulfate resistance. Therefore, one must expect a deficient long term frost resistance.

Stark and Ludwig [1995] have showed that the inferior salt scaling resistance of slag cement concrete probably depends on a combined effect of frost and dissolution of the carbonated surface. This means, that a salt scaling test of traditional type, where there is no possibility of carbonation between individual freeze/thaw cycles, will give completely misleading results. The scaling in practice will be much higher than in the test.

Conclusions: Mineral admixtures shall preferably not be used in concrete exposed to long time exposure to moisture with and without salt, and repeated frost. Low amounts of silica fume can, however, be accepted.

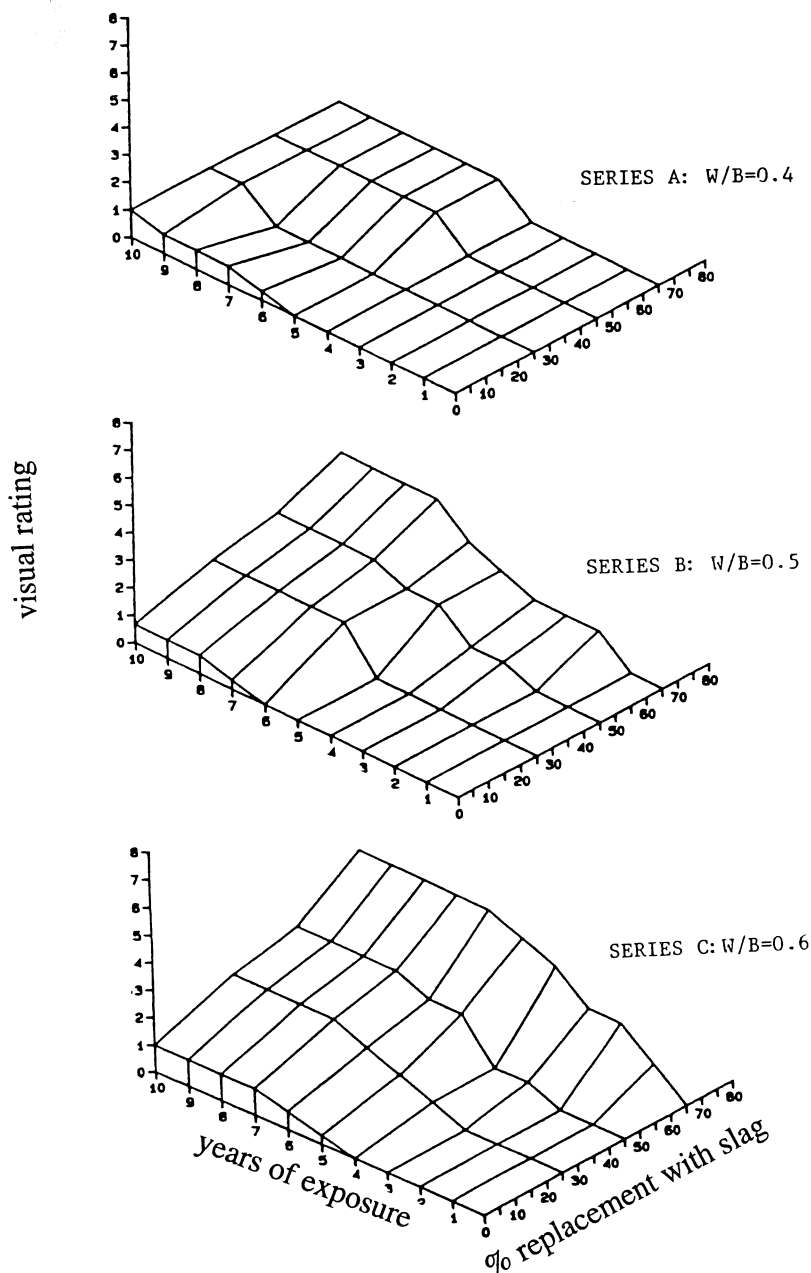

Fig 47: Result of exposure tests at Treat Island in Canada on the long-term behaviour of air-entrained concrete with ground granulated blast furnace slag; Bremner et al [1989].

9.3 Air-entraining agents

Different air-entraining agents produce concrete with different frost resistance, when the air content is constant. One example of a test of different admixtures is seen in Fig 48. Evidently, the admixture of type LP1 is better than the admixture of type LP2, especially at lower air contents. Another example was shown in Fig 39.

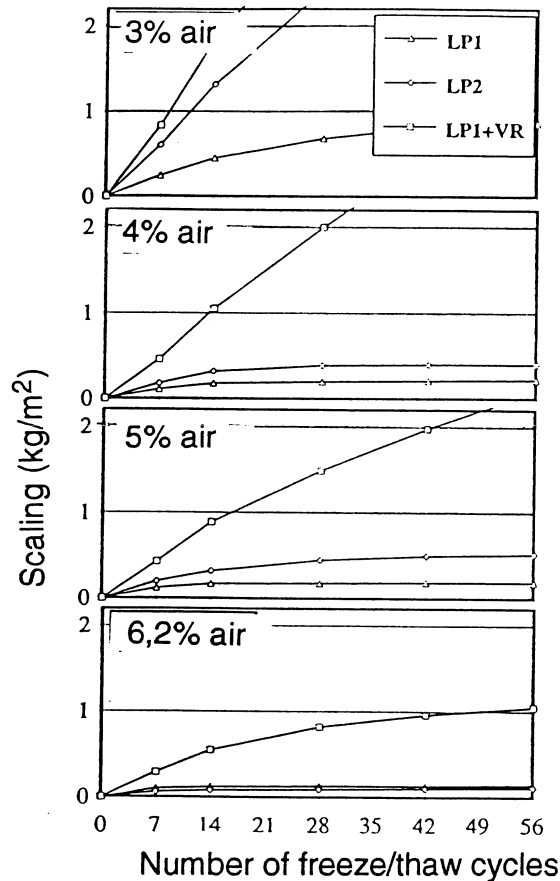

Fig 48: Salt scaling curves of air-entrained concrete with two different pure air-entraining admixtures and one combination of an air-entraining admixture and a water reducing agent; Malmström [1990].

The air-entraining agent must, therefore, be selected with great care. It is important to use admixtures that are well-defined, chemically and physically, so that each new delivery contains a product with exactly the same properties as the previous deliveries. Therefore, admixtures based on waste materials, for example lignosulfonates coming from the paper industry, might be unsuitable for the production of high quality concrete.

It is also necessary to select an air-entraining admixture, that can produce stable (redundant) air-pore systems in the fresh mix; air-pore systems, that do not change negatively during handling, placing, and compaction of the mix. It is a very complicated task to select the proper combination of admixtures. It must be based on pre-tests of the frost and salt scaling resistance of concrete of the actual type. The concrete recipe, obtained during the test, shall be used unchanged, until new pre-tests with new recipes are made.

9.4 Water reducing agents and superplastzicers

The use of water reducing agents will normally decrease the frost resistance, compared to the case where only pure air-entraining agents are used. Examples are shown in Fig 48. Two types of air-entraining admixtures were used alone. One of the air-entraining admixtures was also combined with a water reducing agent. 4 different air contents were tested. The addition of the water reducing agent reduced the frost resistance. Other researchers have obtained similar results; e.g. Fagerlund [1988]. Therefore, if possible, one should avoid the use of water reducing agents in frost resistant concrete. Normally, this is not possible, however, due to problems with the workability of the concrete.

Different admixtures have different effects as regards the function of the air-entraining agent. Therefore, the water reducing, or superplastzising agent must be selected with care, so that it is compatible with the air-entraining agent and the cement. Unsuitable combinations will produce concrete with unstable air-pore systems, and unsuitable air-pore size distributions. In most cases, the frost resistance is reduced when the consistency of the fresh concrete is made more fluid. Some examples are seen in Fig 49. There is also an effect of the types and of the combinations of the plasticizing admixture(s). Admixtures and admixture combinations that create unstable airpore systems shall never be used.

The selection of the admixtures must be based on pre-tests of concretes involving salt scaling and ordinary frost tests.

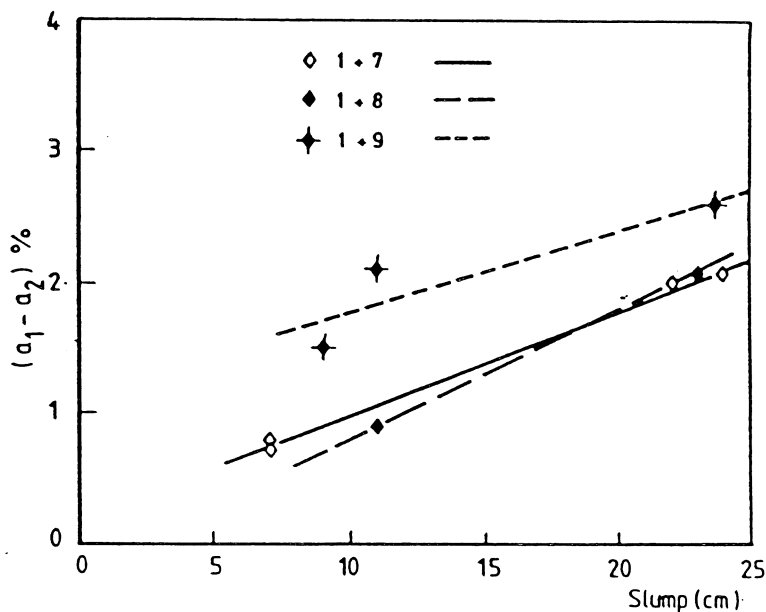

Fig 49: Effect of the slump value on the loss in the air content when the concrete is poker-vibrated (air content a_2) instead of table-vibrated (air content a_1); Fagerlund [1988]. Three types of superplastzicing agents.

9.5 Aggregate

The importance of having an aggregate with low porosity was described in paragraph 3.2. The vacuum saturated porosity shall not exceed 1%. Besides, the potential frost durability of the embedded coarse aggregate shall be tested by a special freeze/thaw test, in which the expansion of the specimen is measured; see paragraph 10.4.

9.6 Mixing

The air-pore system is normally improved, both with regard to its structure, and to its stability, when the mixing time is prolonged. Therefore, a short mixing time can normally not be used. It often has to be prolonged compared with the normal mixing time. The minimum mixing time must be determined on the basis of pre-studies in full scale. During these pre-tests, specimens shall be prepared from the different mixes. They shall then be tested with regard to the frost and salt scaling resistance. The freeze/thaw results should be used as a basis for the selection of the proper mixing time.

9.7 Curing

The curing of the concrete is not so crucial for frost resistance, as it is for corrosion. Therefore, normal curing procedures, as those needed for a high resistance to reinforcement corrosion, are also sufficient for frost and salt scaling resistance. The effect of curing on the permeability, and the salt resistance of concrete, has been studied by Ewertsson and Petersson [1992], among others.

The frost resistance is improved if the concrete has a possibility to dry once before it is exposed to its first frost ; see Wong et al [1972]. Therefore, concrete that is cast in spring and in summer, normally has a somewhat higher frost resistance, than concrete that is cast in late autumn and in winter.

10. Test methods for frost and salt scaling resistance

10.1 General

As said in paragraph 2.1, there is need of two types of freeze/thaw tests; one for salt scaling, and another for inner frost damage. All practical experience show, however, that salt scaling is much more aggressive than inner frost damage. Besides, both destruction types are, probably, basically depending on the same type of physical destruction mechanism; pressure caused by water, that migrates towards and/or from the site of ice formation. Thus, for both types of destruction, a sufficiently high air content, combined with a sufficiently low water/cement ratio, is needed for making the concrete durable. The air content must, however, be higher for salt scaling than for internal damage caused by the freezing of pure water. Besides, the water/cement ratio must be smaller. *Therefore, if the concrete is resistant to salt scaling, it is in almost all cases also resistant to inner frost damage.*

Only a salt scaling test is, therefore, sufficient in most cases. There is, however, a destruction type, that will not necessarily be detected by a salt scaling test, and that is destruction caused by the freezing of water inside coarse aggregate, or in interfaces between coarse aggregate particles and the cement paste. Therefore, a test should also be made of the potential risk of this type of damage. This test can however be made only once, as a pre-test in conjunction with the selection of the coarse aggregate to be used, and as a control, that the air-pore structure is in order. The salt scaling test, on the other hand, is indirectly a test of the quality of the air-pore system. Therefore, it might be repeated after a certain time, and might also be used as a production test. A major problem, however, in conjunction with the use of a freeze-test as a production test, is the long duration of the test. The first reliable results are obtained after about 2 months. The test is not completed until 3 months after casting. This limits the possibility of using a freeze test, such as the salt scaling test, for production control.

There are many test methods to select between. The methods are at a first sight similar, but might vary as regards, the "wetness", the minimum temperature, the freezing rate, the "salinity", etc. It is suggested that well-established test methods are used, for which there are good and well-established correlations between the behaviour in the test and in practice.

10.2 Salt scaling

The Swedish test method for salt scaling SS 13 72 44; "Concrete testing-Hardened concrete-Frost resistance" (present version from 1988), also called "The Borås Method", has been in use in Sweden during about 10 years. From 1988 it is a mandatory method for control of the concrete to be used in Swedish bridges. It is suggested as a RILEM Test Method; RILEM [1995A]. The principles of the method are as follows. For details refer to the text of the Standard:

- * The specimens are prepared from 150 mm cubes that are made in the following way: The cube mould is fastened to a vibrating table (50Hz, vertical amplitude $\pm 0,5$ mm without load). Then, the mould is filled in 2 layers. Each layer is compacted by vibration during a fixed time, the length of which depends on the consistency; see Table 4. The cubes are stored in water during 5-7 days and are then stored in a climate chamber with well-defined RH and temperature (according to what is now known, this drying phase is crucial. Therefore, the climate must be controlled to a high precision. In a planned revision of the Swedish Standard, the following climate is prescribed: RH, $65\pm 5\%$; Temperature, $20\pm 2^\circ\text{C}$. The evaporation from a well-defined water-filled vessel, stored with the specimens, shall be 45 ± 15 g/m²·h.)

Table 4: Vibration time of each layer

Consistency		Vibration time (s)
Slump (mm)	Flow table (mm)	
≤ 150	≤ 440	15
160-200	450-520	10
200-240	530-620	5

- * At the age of 21 ± 2 days, a slice of 50 mm thickness is cut from each cube. One of the saw-cuts runs through the centre of the cube, and the other about 25 mm from the cast surface. The saw-cuts shall be parallel to the direction of the casting of the specimen. The central saw-cut is used as the exposed surface in the test.
- * The slices are stored for additional 7 days in the same climate as before. During this period, a rubber membrane is glued to all sides, except the surface, that shall later on be exposed to the salt solution. The edge of the rubber membrane shall extend 20 mm above the exposed surface, so that the salt solution can be ponded. The specimen is immediately returned to the climate chamber.
- * After a total period of 7 days in the climate chamber, the freeze-surface is covered by tap water which is kept for 3 days, until the salt scaling test starts.
- * Immediately before the scaling-test starts, the water is poured out, and the concrete slice is placed in a heat insulating box consisting of 20 mm expanded polystyrene in the sides and the bottom. The insulation covers all sides of the specimen, except the exposed surface. This is covered by a 3% NaCl-solution, to 3 mm depth. The solution is covered by a thick polyethylene foil, so that evaporation is hindered. The test set-up is shown in Fig 50.
- * The freeze-test starts immediately, and it is run for 56 cycles. Each cycle lasts for 24 hours and consists of about 16 hours of freezing and 8 hours of thawing. The temperature in the solution shall lie within the shadowed field in Fig 51.
- * The material, that is scaled off from the specimen, is collected during the thawing phase, after 7, 14, 28, 42 and 56 cycles. It is dried, and weighed, and expressed in kg per m² of exposed area. The salt solution is renewed before the new series of cycles starts.

* A minimum of 4 specimens is used in connection with the pre-testing of concrete. For an eventual production testing, fewer, or even single, specimens can be used.

* The result is assessed according to the following table².

Table 5: Requirements for different degrees of salt scaling resistance

Salt scaling resistance	Requirement
Very good	No specimen is scaled more than 0,10 kg/m ² after 56 cycles
Good	The mean value for the scaling after 56 cycles is less than 0,50 kg/m ² and $m_{56}/m_{28} < 2$ ¹⁾
Acceptable	The mean value of the scaling after 56 cycles is less than 1,0 kg/m ² and $m_{56}/m_{28} < 2$
Unacceptable not met	If the requirements for acceptable salt scaling resistance are not met

1) m_{28} and m_{56} is the mean scaling after 28 and 56 cycles.

As shown in paragraph 2.2.2, the criteria are well-founded because:

- The criterion for good salt scaling resistance, 0,50 kg/m² after 56 cycles, approximately corresponds to a maximum scaling of about 5 mm after 100 years of exposure, provided there are 10 "severe" freezing cycles each year.
- The criterion for acceptable salt scaling resistance, 1 kg/m² after 56 cycles or 0,5 kg/m² after 28 cycles, correspond fairly well to the limit found between retarded and accelerated salt scaling; see Fig 7.

According to the Swedish Bridge Norm, the following requirements shall be complied with:

- Pre-test: The minimum requirement: "Good salt scaling resistance".
- Production test: The minimum requirement: "Acceptable salt scaling resistance".

A review of Swedish experiences of the method is given in Petersson [1993]. It is quite clear, that the quality of Swedish concrete for bridges has improved very much after the test method became mandatory in 1988. In Fig 52 are shown, in chronological order, the results of all pre-tests of concrete performed during one year at the Swedish National Testing and Research Institute in Borås. Each point is the mean value from 4 specimens. Only 6 results (2,5%) are above the requirement for pre-tests, 0,5 kg/m² corresponding to "Good salt scaling resistance", and there are 220 results with a scaling of less than 0,2 kg/m². The average result is as low as 0,1 kg/m².

² The test can be prolonged to 112 cycles. In the Swedish Bridge Norm, this is prescribed for concrete with silica fume. The reason is the observations that such concretes sometimes obtain an accelerated scaling after 56 cycles. Such behaviour is not allowed according to the Swedish rules. When 112 cycles are used, the criteria for scaling according to Table 5 are increased by a factor 2.

The lowest temperature is perhaps too unprecise. As shown in paragraph 4.1, it also seems reasonable to lower the minimum temperature to -22°C. Therefore, the use of a minimum temperature of -22°C±1°C should be considered. It must be remembered, however, that the method, as it is described now, has been in use for many years with good results.

- A: Thermocouple
- B: Evaporation protection
- C: Salt solution
- D: Specimen
- E: Moisture protection
- F: Heat insulation

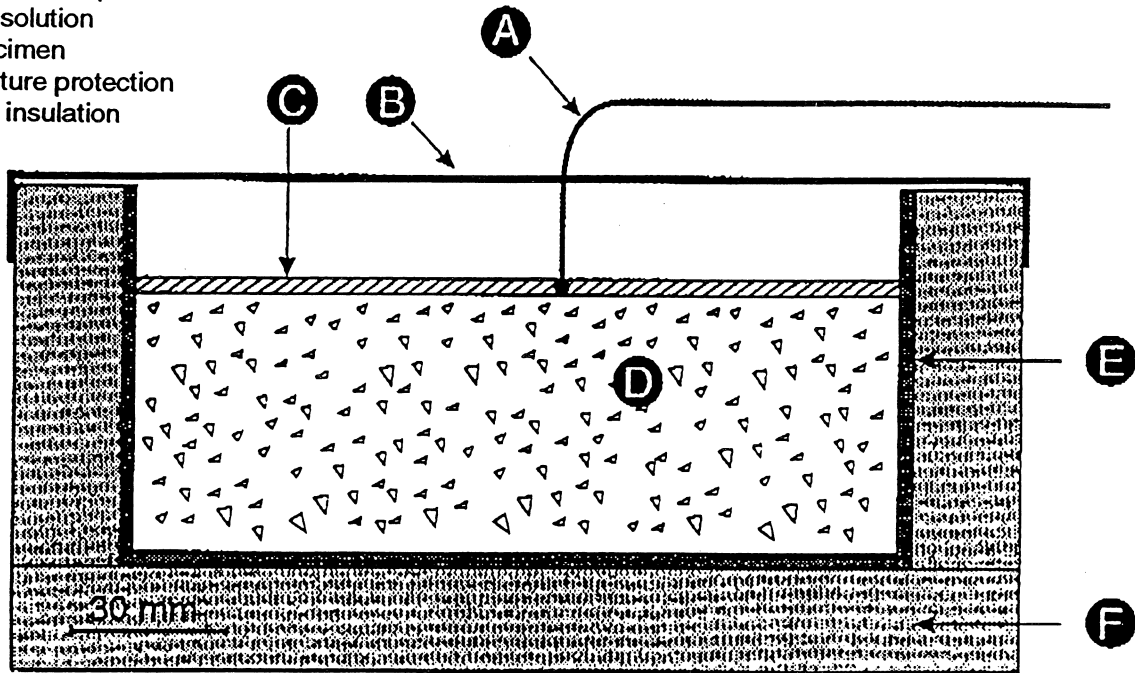

Fig 50: The test set-up of the Swedish standardized salt scaling test, SS 13 72 44.

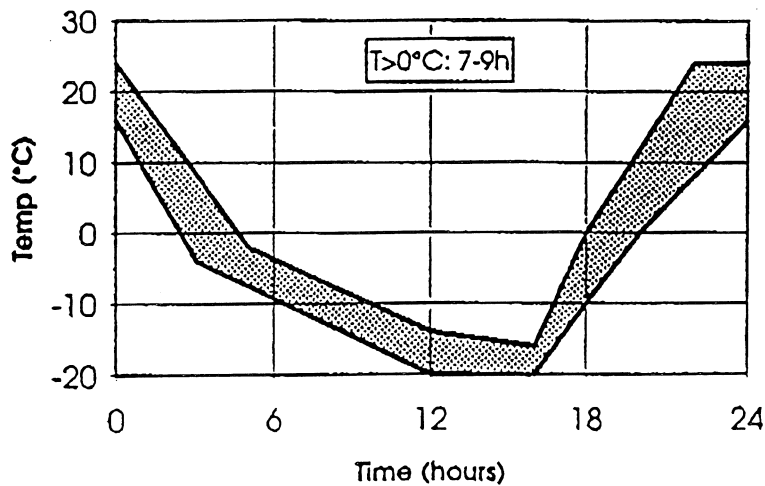

Fig 51: The prescribed freeze-thaw cycle in the Swedish standardized salt scaling test SS 13 72 44.

The results of the production tests, during the same year, are shown in Fig 53. These results are even better; only one result is above the acceptance criterion for production test, 1 kg/m^2 corresponding to "Acceptable scaling resistance". The average scaling is $0,09 \text{ kg/m}^2$, or "Very good salt scaling resistance".

The pre-treatment of the specimens seems to have a big influence on the test result. If the concrete is never dried, or if it is exposed to hard drying, the salt scaling seems to be enhanced. Therefore, in the test method, a moderate drying is used, which might represent the real condition in a reasonably good manner. If the concrete is never dried, it contains water in in-

terfaces, and in other defects. This water might cause trouble. This water is lost even at a mild drying, but it is not regained when the dried concrete is put in water once again. If the concrete is dried hard, the freezable water is increased; perhaps to an unnaturally high level; see Fig 9 and 13.

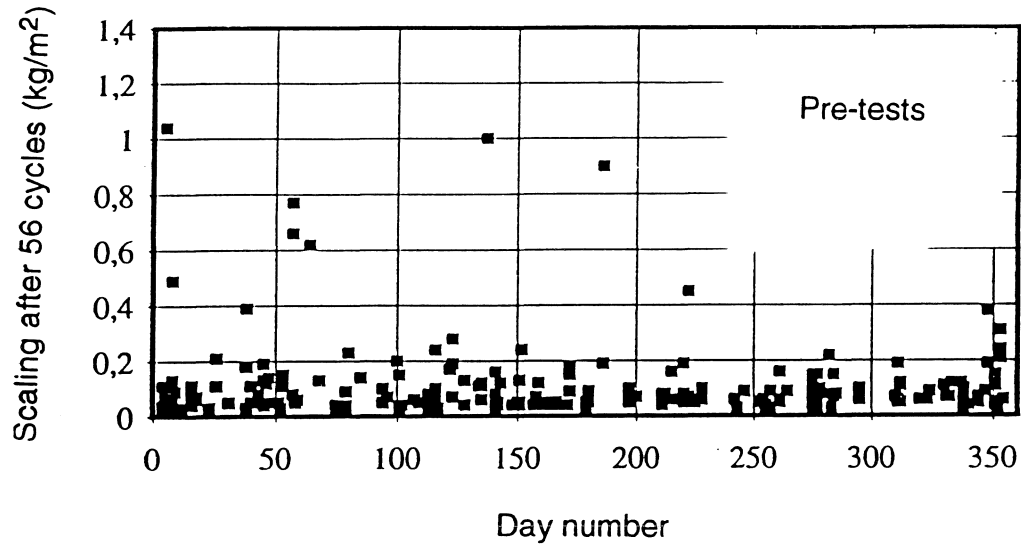

Fig 52: All results in chronological order of pre-tests performed at SP during 1 year of the salt scaling resistance of concrete for bridges in Sweden; Petersson [1993]. (SP is the Swedish National Testing and Research Institute)

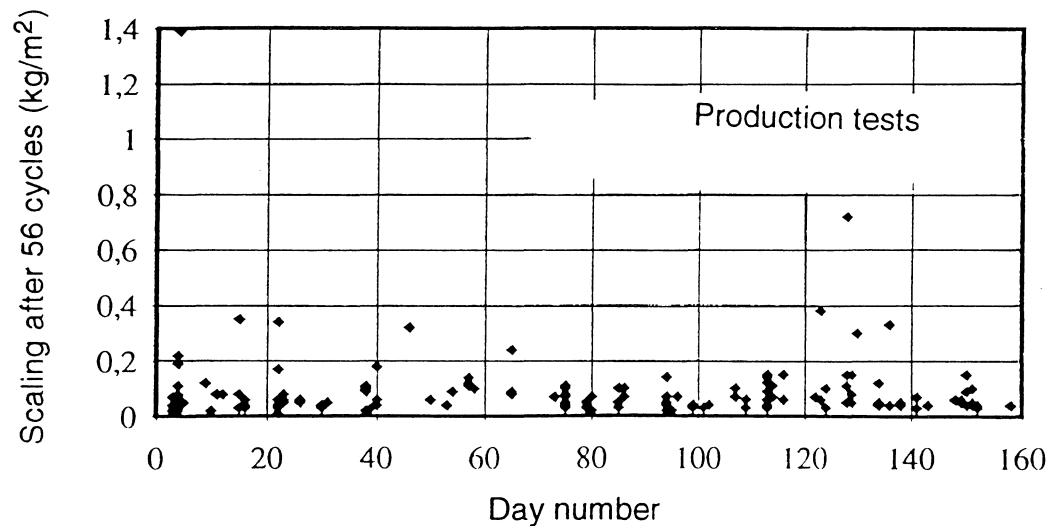

Fig 53: All results in chronological order of production tests performed at SP during 1 year of the salt scaling resistance of concrete for bridges in Sweden; Petersson [1993].

The effect of a natural exposure on the salt scaling resistance in the test is demonstrated in Fig 54. Concrete specimens of 8 types, made with pure Portland cement, were split in two groups; one group was treated according to the Standard, and was then tested with regard to the salt scaling resistance. The other group was placed outdoors for 9 months, exposed to a marine environment, near the sea level. Then, the specimens were tested with the salt scaling method. The natural exposure did not produce more scaling, than the exposure prescribed by the Standard.

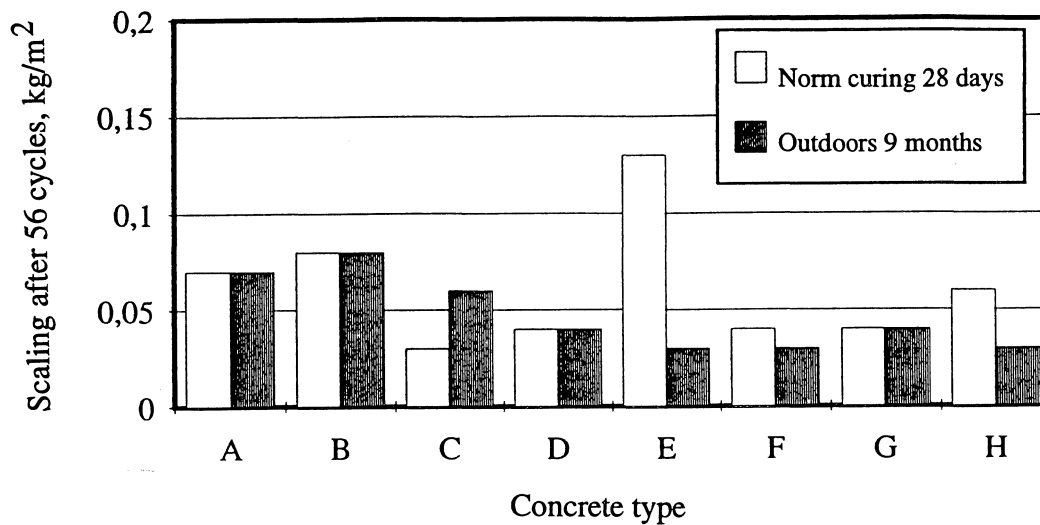

Fig 54: Salt scaling after 56 freeze/thaw cycles of 8 different concrete mixes (A-H) either pre-treated according to the Standard SS 137244 or stored outdoors in marine environment during 9 months before the salt scaling test; Petersson [1993].

The Standard SS 13 72 44 describes 4 different procedures for testing, depending on the origin of the specimen, and the type of test surface:

Procedure I: Testing of sawn surfaces of cast freeze/thaw specimens (cubes). This is the method described above.

Procedure II: Testing of real upper surfaces of cast freeze/thaw specimens (cubes).

Procedure III: Testing of sawn surfaces of specimens drilled out from the real structure.

Procedure IV Testing of real surfaces of specimens drilled out from the real structure.

Alternative salt scaling tests, which might also be used, are:

- 1: *The CDF-Test*, which is a RILEM Draft Recommendation; RILEM [1995B]. It was developed at the University of Essen. An investigation of the precision of the method is presented by Setzer and Auberg [1995].
- 2: *The Cube Test*, which is a RILEM Draft Recommendation; RILEM [1995A]. The method has been in use for many decades in Germany, particularly in Düsseldorf at the Research Laboratory of The German Cement Manufactures (VDZ).

10.3 Multi-cycle unisolated freeze/thaw

The most frequently used, traditional freeze/thaw test method without salt is the American method ASTM C666; "Resistance of concrete to Rapid Freezing and Thawing". There are two variants of the method:

- * Procedure A: Rapid freezing and thawing in water.
- * Procedure B: Rapid freezing in air and thawing in water.

Principally, the methods A and B are the two methods "Rapid Water" and "Rapid Air", that were used in Fig 16 and 17. The methods can be summarized in the following way:

* The freeze/thaw cycle

Procedure A: "Rapid Water":

Cooling from $+4,4 \pm 1,7$ °C to $-17,8 \pm 1,7$ °C, and warming from $-17,8 \pm 1,7$ °C to $+4,4 \pm 1,7$ °C within 2 to 5 hours. More than 25% of the cycle shall be used for thawing. Both freezing and thawing is made with the specimen surrounded by 1 to 3 mm of water on all sides.

Procedure B: "Rapid air":

The same cycle, but more than 20% of the cycle shall be used for thawing. Freezing is made with the specimen surrounded by air on all sides and thawing is made by the specimen surrounded by 1 to 3 mm of water on all sides.

* Specimens

The typical specimen is a prism or a cylinder with a length between 279 and 406 mm, and a width between 76 and 127 mm. Normally, the specimens are stored in saturated lime water, from unmoulding until the start of the test. Hence, they are normally not pre-dried as in the Swedish salt scaling test.

* Measurements. The "Durability Factor"

With an interval of maximum 30 cycles, the specimens are tested with regard to:

1: *The fundamental frequency of transverse vibration, n_i .* From this, the change of the dynamic E-modulus is calculated:

$$P_c = E_i/E_o = [n_i/n_o]^2 \cdot 100\%$$

Where E_i and E_o are the E-moduli after i cycles, and before freeze/thaw, and n_i , and n_o are the fundamental frequencies, after i cycles, and before freezing.

2: *The length* (optional). The relative length change is:

$$L_c = \{ [L_i - L_o] / L_o \} \cdot 100 \%$$

Where L_i and L_o are the length after i cycles and before freeze/thaw.

3: *The weight:* This is measured in connection with the measurement of the E-modulus.

The testing is made until 300 cycles, or until the test is interrupted because the E-modulus is reduced to 60% of the initial value, or until the length increase is 0,1% (optional).

The "Durability Factor", DF is defined:

$$DF = P_c \cdot N / 300$$

Where P_c is the relative E-modulus at N freeze/thaw cycles. It is defined above.

Example: The test is terminated after 200 cycles. Then, the observed relative E-modulus is 60% of the initial. $DF = 60 \cdot 200 / 300 = 40\%$.

Example: The test is terminated after 300 cycles. Then, the observed relative E-modulus is 80% of the initial. $DF = 80 \cdot 300 / 300 = 80\%$

In the Specification, no criterion is given for the minimum acceptable Durability Factor. The level 80% is sometimes used; c.f Fig 33.

A test method of this type is very sensitive to small changes in the procedure. This is clearly seen in Fig 16 and 17. The spread in the result between different laboratories is quite big. According to the Test Specification from 1992, no modern data exist, making it possible to evaluate the multilaboratory precision. Besides, it is difficult to know when one should use Procedure A, and when one should use procedure B. It is quite clear from Fig 16 and 17, however, that Procedure A is much more harmful than Procedure B. Therefore, it seems reasonable to use Procedure A for concrete structures that are exposed to moisture during long periods.

The method is very rapid; the allowed freezing rate varies, between about 6°C per hour, to about 15°C per hour. Besides, the duration of the cycle varies by a factor 2,5. Therefore, the inner pressure caused by the freezing water, as well as the possibility of the specimen to absorb water, is very different depending on how the test is performed. This is unsatisfactory, from a theoretical point of view. If the method should be used, the cycles ought to be better defined, and the minimum temperature ought to be lowered, so that the cycle corresponds better to natural conditions in cold climate. A reasonable freezing rate might be 3°C per hour, and a reasonable lowest temperature might be -22 ± 1 °C, as was suggested for the salt scaling test (See footnote 2). Thus, the duration of the cycle is prolonged to about 12 hours. With 300 cycles, a total test period of 150 days is, therefore, required. This shall be compared with the 30 to 70 days required, if the ASTM specification for the freeze/thaw cycle is followed.

The big problems in defining the exact relation between the Durability Factor observed in the test, and the frost resistance in practice, makes the test method a bit dubious. It is reasonable to assume, however, that a concrete tested according to procedure A, and having a Durability Factor above 90 %, has a high degree of durability also in the practical situation.

10.4 Critical dilation

10.4.1 Test principles

A concrete, that is more than critically saturated, will expand during freezing. This is the basis behind the American method ASTM C671; "Critical Dilation of Concrete Specimens Subjected to Freezing".

The characteristics of the test are as follows:

- * Normally, the specimen is a cylinder with diameter 75 mm and length 150 mm.
- * Between every freezing, the specimen is stored in water at +1,7°C. Thus, between the individual freezings, it is gradually increasing its degree of saturation.
- * The freeze-test is made by measuring the length change of the specimen when it is freezing with a rate of $2,8 \pm 0,5$ °C per hour from, +1,7°C to -9,4°C, without moisture exchange with the surroundings. When the minimum temperature is reached, the specimen is immediately returned to the water bath, where it is stored until the next freezing is performed.

The length-temperature curve is monitored; see Fig 55. The dilation is defined as the maximum expansion above the extrapolated thermal contraction curve, defined by the contraction before freezing; see Fig 55. When the degree of saturation is below the critical, the concrete will not dilate, but contract; see Fig 27.

- * The test is repeated until the critical dilation is obtained, or until the maximum water storage time, that is specified, is reached. The water storage time between two successive freezings shall preferably be constant.

* Critical Dilation is defined in the following way: The dilation is plotted versus the number of cycles (or versus the water storage time). Critical Dilation is not obtained as long as there is no dilation at all, or as long as the rate of the increase in dilation is constant. Critical Dilation is obtained when there is a sudden increase in the dilation compared with the dilation during the immediately preceding freezing. By "sudden" is meant that the dilation increases by a factor of at least 2.

* Critical Dilation defines a "Period of Frost Immunity". This is the total water absorption time until the freezing that was made *before* the Critical Dilation was obtained.

A concrete with a high degree of frost resistance shall have a very long "Period of Frost Immunity". In fact, for a concrete that can suck water continuously during its entire service life, the critical dilation shall never be reached, even after years of water absorption.

According to the Specification, the concrete shall be frozen when immersed in kerosene, that is saturated with water. This is however not necessary. One might just as well freeze in a climate chamber with controlled temperature lowering of the air, provided the specimen is sealed from moisture loss by wrapping it in a heavy plastic foil.

The method is suitable for control of the frost resistance of the coarse aggregate, and for control of the effect of interfaces, etc. Then, it is reasonable, however, to lower the temperature to at least $-22 \pm 1^\circ\text{C}$, which is the temperature suggested for the salt scaling test (see footnote 2).

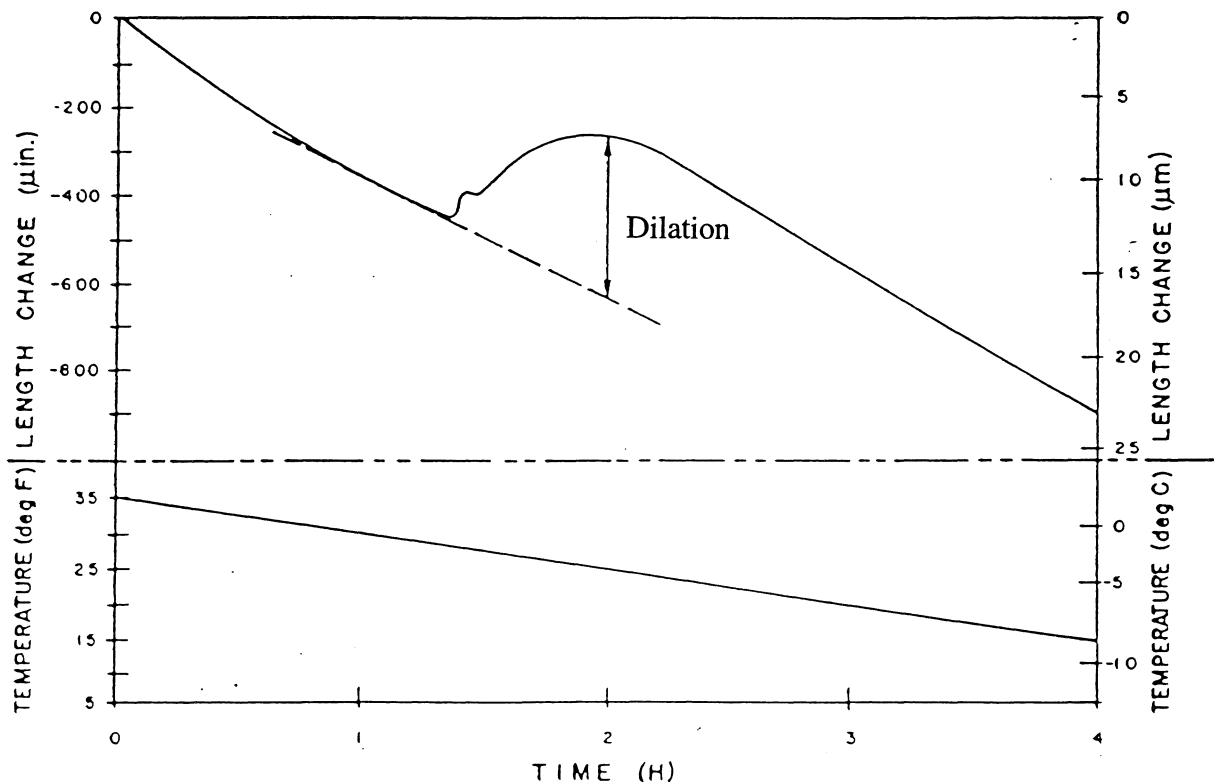

Fig 55: Examples of length change and temperature curves in the critical dilation test ASTM C671. Definition of "dilation".

10.4.2 Control of coarse aggregate; ASTM C682

The use of the test method for control of coarse aggregate is specified in the American test method ASTM C682; "Evaluation of Frost Resistance of Coarse Aggregates in Air-Entrained Concrete by Critical Dilation Procedure". The principles of the test are as follows:

- * The aggregate is stored in a way, that is natural for its use in practice. Thus, it shall have a moisture content, that is the absolute maximum it might obtain in practice. It, therefore, seems reasonable to store the aggregate for a long period immersed in water, before it is used in the concrete mix.
- * The aggregate is used in a concrete which is air-entrained with the air content $6\pm 1\%$. It is important that the cement mortar phase in the concrete has a very high degree of frost resistance in itself. At least 12 specimens of the size described above (diameter 75 mm and length 150 mm) are made.
- * All the specimens are stored in water of $+23^{\circ}\text{C}$ during 13 days. Then, at least 3 specimens are placed in water of $+1,7^{\circ}\text{C}$ for 3 weeks. At least 3 specimens are dried in 75% RH at $+23^{\circ}\text{C}$ during 1 week, followed by re-saturation in water of $+1,7^{\circ}\text{C}$ during 2 weeks. The other specimens can be stored in other ways, for example during a longer period in water, or by other procedures that represent the real use of the concrete.
- * The freeze-test is made as described above in ASTM C671. The critical Dilation -if any- is determined, and so is the "Period of Frost Immunity".

As said above in 10.4.1, it is reasonable to lower the temperature to $-22\pm 1^{\circ}\text{C}$, and to accept freezing in air, under condition that the specimen is sealed.

10.5 The critical degree of saturation method

Most freeze/thaw tests only give *qualitative* information of frost resistance. They tell little about the service life of the structure. One exception is the scaling test, that might, as shown in paragraph 2.2.2, be used for a rather uncertain estimate of the future scaling and service life. For inner damage, the so-called Critical Degree of Saturation Method could be used for a *quantitative* estimation of the service life. The method gives a certain possibility to predict a parameter that is called "The potential service life". This is defined as the time the concrete can be constantly stored in water without being damaged by frost; Fagerlund [1979].

The method is described in Fagerlund [1977]. It is performed in the following way. Two tests are made:

Test 1: The critical degree of saturation S_{CR} is determined by a freeze/thaw test performed on moisture-sealed specimens. The test can be made by repeated freeze/thaw of a series of specimens in which each specimen has been pre-conditioned to a certain degree of saturation. The critical degree of saturation is defined by the degree of saturation where there is a more or less drastic transition from unharmed to harmed specimens. It can also be determined by measurements of the length change of specimens that are pre-conditioned to different degrees of saturation. The critical degree of saturation is defined by the degree of saturation where the concrete starts to expand during freezing. Thus, the test is a dilation test similar to that in ASTM C671. [Degree of saturation is defined by Eq(1)].

Test 2: The capillary degree of saturation is determined by a water uptake test where rather small concrete specimens are stored in water for one month or more. The weight increase curve is transformed into a degree of saturation curve, S_{CAP} -curve. The absorption curve is adjusted to an equation of the following type:

$$S_{CAP} = A + B \cdot t^C \quad (29)$$

Where

A, B, C are constants
t is the water absorption time.

The potential service life, t_{pot} , is ended when S_{CAP} equals S_{CR} . Therefore, t_{pot} can be calculated by:

$$t_{\text{pot}} = \{(S_{\text{CR}} - A)/B\}^{1/C} \quad (30)$$

A concrete, which has a long potential service life, defined by this method, will have a high frost resistance also in the practical situation.

Note: The method is similar to the Critical Dilation method. The main difference between the two methods is that the S_{CR} -method separates the determination of S_{CR} from the determination of S_{CAP} . Therefore, one has the possibility to calculate the service life. In the Critical Dilation test one will only know the potential service life in a case where critical dilation is obtained during the test. In this case, the potential service life is equal to the "Period of frost immunity".

11. Recommendations for a quality control system

11.1 General principles

The principles below could be used for advanced concrete structures for which a long service life is required. Frost resistance and salt scaling resistance can be secured by the following measures:

- 1: Pre-tests of the salt scaling resistance, by SS 13 72 44, of specially cast freeze/thaw specimens, and on cores from big specimens (blocks) cast in a way that, as closely as possible, resembles the real production. On the basis of these pre-tests, the concrete constituents (cement, admixtures, consistency etc) are selected, and the minimum air content of the fresh and hardened mix is established³. As shown above, the cement type, the type of admixtures, and the consistency are fundamental for frost resistance. Therefore, no change is allowed, neither in the constituents, nor in the consistency, nor in any other concrete parameter of importance, before a new approved pre-test has been made.
- 2: Pre-tests of the potential frost resistance of the coarse aggregate, and of the effect of porous interfaces, and other normal "defects". Dilation tests of the type described in ASTM C671 can be made. Another possibility is to use the critical degree of saturation method.
- 3: The specification of an absolute minimum air content of the fresh mix. This is used even when the pre-test indicates, that a lower air content might be used.

The following general minimum values are suggested. They could be applied even in a case where the pre-tests indicate that a lower value might be used, which will give an extra safety:

**Salt scaling: The minimum air content could be:
16% of the volume of cement plus mixing water**

**Freezing in pure water: The minimum air content could be:
12% of the volume of cement plus mixing water**

Example 1: Freezing in pure water. Cement content 300 kg/m³; w/c-ratio 0,60; cement paste volume 27,6%. *The minimum air content 3,3%.*

Example 2: Salt scaling. Cement content 380 kg/m³; w/c-ratio 0,40; cement paste volume 27,4% *The minimum air content 4,4 %.*

³) By "air content" of the fresh mix is meant the air content after transport and pumping. This can be exchanged for the air content directly after mixing, or the air content after transport, provided a safe relationship between these air contents and the air content after pumping can be established.

Example 3; Salt scaling. Cement content 450 kg/m^3 ; w/c-ratio 0,40; cement paste volume 32,4%. *The minimum air content 5,2%.*

It can be noted, that an air content of 4,4% in a concrete with the cement paste volume of 27,4% (Example 2), or a concrete with 5,2% of air in a concrete with the cement paste volume 32,4% (Example 3) correspond to a Powers spacing factor of about 0,20 mm when the specific area of the air-pore system is 25 mm^{-1} . This is normally, but not always, a concrete with a high degree of salt scaling resistance; see Fig 30 and 31. An air content of 3,3% in a concrete with the cement paste volume 27,6% (Example 1) and the same air-pore system as in the examples above corresponds to a Powers spacing factor of 0,23 mm, which normally ought to give a high frost resistance when freezing takes part in pure water; see Fig 28.

As said above, the Powers spacing factor is, however not a perfect parameter for describing frost resistance.

- 4: The specification of an absolute minimum air content of the hardened mix. This is used even if the pre-test indicates that a lower air content might be used. A suitable value might be 3 or 3,5 vol-%.
- 5: Production tests of the air content of the fresh concrete (for definition of "air content", see footnote 3). This test is done frequently. The testing of every concrete batch might be considered. The air content is not allowed to be lower than the minimum air content required according to the pre-tests, described in 1: above.
- 6: Production tests of the salt scaling resistance of specimens, that are manufactured at the building site. The specimens are made in exactly the same manner as the specimens for pre-testing. A problem with such a test is the long time it takes to obtain safe results.
- 7: Tests of the air content of the hardened concrete, and of the salt scaling resistance of drilled out specimens from the finished structure. The frequency of these tests can be varied, depending on the results. By making early tests, one has a certain possibility of changing the mix within reasonable time, in such a case where the test results -e.g. the air measurements- indicate the possibility of a defective salt scaling resistance.

Air-pore analyses of the spacing factor, and/or the specific area, are not recommended to be used for quality control, due to the uncertain relationships between these air-pore parameters and the frost resistance. Such analyses might, however, be a valuable tool for establishing the concrete recipe to be used. Problems in obtaining the proper frost resistance during the pre-test stage might also be explained by the air-pore structure.

The following freeze-tests can be used: (i) the Swedish salt scaling test SS 13 72 44, (Procedure I for cast specimens, and Procedure III or IV for drilled out specimens), (ii) the American Critical Dilation test, ASTM C671. Some modifications in the procedures and in the acceptance criterions should, however, be made. They are described below.

11.2 Pre-tests

11.2.1 Pre-test of the salt scaling resistance

The concrete, to be used in the structure, ought to be designed on the basis of comprehensive pre-testing of its salt scaling resistance. During this testing, target values for the air content of the fresh and the hardened concrete should be established. During production, the air contents, should comply with the target air contents.

A number of different mixes are produced, transported, and pumped. At least 4 cubes of each mix are made from the pumped concrete. They are tested according to SS 13 72 44,

Procedure I, preferably prolonged to 112 cycles. This prolongation is necessary when the concrete contains mineral admixtures, especially silica fume.

It is also recommended that big concrete blocks, are produced from each mix in a manner that is representative of the real production; i.e. the concrete shall be mixed in the full-scale production mixer, and it shall be transported, pumped and compacted in the same manner as in the real structure. Specimens (diameter ≈ 15 cm, length ≈ 20 cm) are drilled from different parts of each block. The specimens are stored and tested in exactly the same manner as cast specimens used for salt scaling tests. Testing could be made with the Swedish test method SS 13 72 44, Procedure III. Preferably, the test is prolonged to 112 cycles.

By making many mixes, with different air contents, and different admixture/cement combinations, a redundant mix with high salt scaling resistance could be found. It must be possible to repeat such a mix many times with maintained, acceptable, salt scaling results.

The concrete mix is accepted if the following criterions are fulfilled for both cast and drilled out specimens:

- 1: The average scaling after 56 cycles is less than $0,5 \text{ kg/m}^2$
- 2: The average scaling after 112 cycles is less than $1,0 \text{ kg/m}^2$
- 3: No specimen has a scaling after 56 cycles that is higher than 1 kg/m^2 .
- 4: Exactly the same mix (the same recipe) fulfils the same acceptance criterion as in 1., when the mix is repeated, from mixing, until testing of the salt scaling resistance.

The air content of each fresh mix should be determined, using the same compaction method as described in 11.2.1. At least two measurements should be made for each mix, at each point. The air content should preferably be determined at three points:

- 1: Directly after mixing
- 2: Directly after transport
- 3: Directly after pumping

The air content after pumping should normally be used as the target value during concrete production. The target value should be the highest of all values measured during the pre-testing of the concrete mix, that is finally selected⁴.

Non-frozen pieces of the cores, used for salt scaling, should be used for a microscopic analysis of the air content of the hardened concrete. The highest measured value of the air content of the mix, that is finally selected, should be used as the target air content during the production phase⁵.

NOTE 1: The test takes about 3 months, from the time the specimens are cast, until the test is ended. Besides, it is not so easy to obtain an approved mix. Such factors as the cement type, and the types and combinations of the air-entraining and water reducing admixtures, is of very big importance. It might even be, that an approved frost resistance can only be achieved by a certain cement, and a certain admixture. Therefore, it is recommended that the pre-testing of the salt scaling resistance starts early.

NOTE 2: A pre-test is only valid for a given consistency. Thus, renewed full pre-testing ought to be made for every consistency level, even if there is no other change in the concrete than the consistency.

⁴⁾ Big losses in the air content during transport and pumping is a warning signal that the mix might be unstable. A new mix, using other admixtures should be used. Eventually, it is also necessary to change the cement.

⁵⁾ By the microscopical analysis, it is also possible to see defects in the pore structure, such as agglomeration of air-pores, etc. Thus, observations of an eventual defective salt scaling resistance of the cores can be explained. It is however not suggested that the pore structure shall be used for quality control during the production phase.

NOTE 3: A renew pre-testing ought to be made every time anything is changed in the recipe; a new cement, a new aggregate, a new admixture, etc. This new test should be made in exactly the same way as described above, and the concrete shall be approved according to the same principles.

11.2.2 Pre-testing of the "internal" frost resistance by a dilation test

(a) Manufactured smaller specimens

The concretes used for pre-testing of the salt scaling resistance described in the previous paragraph could also be used for a dilation test. A number of cylinders with length/diameter-ratio of 2, and with a minimum diameter of at least three times the size of the coarsest stone, are cast at the building site, after pumping. The casting can be made at the same time as the casting of the specimens for salt scaling. The cylinders are provided with knobs at the ends, for length measurements. They are then stored in water at room temperature.

The first cylinder is tested after about 1 month of water storage, the second after about 6 weeks, the third after about 10 weeks, and so on, until all cylinders have been tested. Eventually, the same cylinder is tested many times, after being stored in water between each testing. The duration of the test -the longest time of water storage- can be 1/2 year, or more.

The dilation test is performed, according to the method ASTM C671, with the following suggested changes; (i) the cylinder size might be different, (ii) the minimum temperature is lowered to -20°C or -22°C , (iii) freeze/thaw is allowed to take place in air, provided the specimen is wrapped in heavy polyethylene foil.

The concrete could be accepted if no specimen show critical dilation after the prescribed longest water storage time; i.e. the "Period of Frost Immunity" should be longer than 1/2 year, or more, depending on the requirements.

If the concrete does not fulfil the criterion for frost resistance, the recipe should be modified, so that an accepted dilation test is obtained. This new concrete mix ought to be pre-tested with regard to the salt scaling resistance, according to the procedure described in 11.2.1.

Note: The dilation test is time consuming. It, therefore ought to start at the same time as the pre-test of the salt scaling resistance of cast specimens described in 11.2.1.

(b) Drilled out specimens

The big blocks described in paragraph 11.2.1 might also be used for a test of the dilation. Cylinders are drilled out of the blocks, at the same time as specimens are drilled for salt scaling tests. The cylinders are provided with knobs for measurement of the length change and are then stored in water of $+20\pm 3^{\circ}\text{C}$. The duration of the water storage ought to be different for each specimen and ought to vary between one month and 6 months, or longer.

The specimens are exposed to a dilation test as described above. No specimen should be allowed to exhibit critical dilation; i.e. the "Period of Frost Immunity" should not be shorter than what is required for the manufactured specimens.

11.3 Production tests

11.3.1 The air content of the fresh mix

The production control could preferably be based on frequent measurements of the air content of the fresh mix, after pumping. The test frequency should be high in the beginning of the production of concrete, and can be reduced when reliable information is gained on the spread in the air content. It is suggested that every concrete batch is controlled during the first period. When a batch has been rejected, the test frequency should be increased again, until the air content is under control.

The test procedure for air should be performed according to the Swedish Standard method SS 13 71 24. The reason is that the compaction is then made by the same method, as that used in connection with the production of specimens for the pre-tests of the salt scaling resistance of the actual concrete. This means, that a vibrating table must be available at the production site. A mini-table used for the Vebe-test could be used. The vibration time is given in Table 4.

A concrete batch, that does not fulfil the requirement regarding the minimum air content, should normally be rejected. It should not be allowed to be used in the structure.

The air content after pumping could be exchanged for the air content after mixing, or after transport, provided there is a well-documented and stable relationship between the air content that is used, and the target air content, which is based on the pumped concrete.

11.3.2 Salt scaling tests on manufactured specimens

It is of a certain value to make production testing of the salt scaling resistance, using specimens that are cast on the building site. The test is time consuming, however; it will take about 2 months from the specimen was made, until 4 weeks of freeze-testing has been performed. Therefore, this production test cannot be used for immediate adjustment of the concrete mix. The result can, however, be used for a general control of the acquired quality.

A test procedure can be designed in the following way:

Cubes for salt scaling tests according to the Swedish Standard SS 13 72 44, Procedure I, are cast at the production site, from concrete that has been transported to the site and pumped. The cubes are prepared according to the specification in the Standard. They are then treated in exactly the same manner as the specimens used in pre-testing of the salt scaling resistance. This means that after demoulding, the specimens have to be transported to the laboratory, in water stored condition.

One cube could be made during each production shift. The concrete could be accepted if the average scaling of an associated series of specimens is below 1 kg/m^2 after 56 cycles. One might, of course, maintain the same criterion, $0,5 \text{ kg/m}^2$, as was used for pre-testing.

11.3.3 Air content of the hardened concrete

Cores (diameter $\approx 15 \text{ cm}$, length $\approx 20 \text{ cm}$) are drilled out of the structure, and are analyzed with regard to the air content. This shall not be lower than the highest of the two values: (i) the target value determined during the pre-testing; (ii) the absolute minimum of the hardened air content.

The location of drilling, and the frequency of coring, depend on the type of structure, and on the test results. Normally, it might be sufficient to test one core for each casting. The frequency must be increased if there are non-complying cores.

The coring, and testing, should be made as early as possible after casting, so that an early warning is obtained, in a case where the air content is too low.

11.3.4 Salt scaling tests of drilled-out specimens

Cores, with the diameter ≈ 15 cm and the length ≈ 20 cm, ought to be drilled regularly from the structure. The specimens should be treated and tested according to the Swedish salt scaling method SS 13 72 44, Procedure III.

Additional cores should be taken from the structure in a case where the result of a production-test of the hardened air content, according to 11.3.3, is too low. The cores should be taken at the place where the actual concrete with low scaling resistance was placed, and at the place where the core used for measurement of the hardened air content was taken. The salt scaling test should be made as described in the beginning of this paragraph.

For all sets of specimens, the mean value of the total scaling should normally be below $0,5 \text{ kg/m}^2$ after 56 cycles. Higher values than 1 kg/m^2 should not be accepted.

12. Important conclusions

Essential conclusions of the analysis performed above are:

- * Internal frost damage is caused by freezing of the concrete in a critically saturated condition. Considerable damage occurs already after a few freezings. Big and irreversible losses in strength, E-modulus and bond occur. Thus, the concrete can not be allowed to become critically saturated during its entire, required, service life.
- * Salt scaling is a surface phenomenon, which increases more or less linearly with increasing number of freeze/thaw cycles. The scaling is often accelerated when the scaling is more than about $0,6 \text{ kg/m}^2$ after 28 cycles in a salt scaling test made in 3% NaCl-solution. A total scaling of $0,5 \text{ kg/m}^2$ corresponds to a scaling depth of about 5 mm after 100 years in a climate where the minimum freezing temperature -20°C is reached 10 times each year.

Scaling has a considerable negative effect on the service life with regard to corrosion of the reinforcement. It might also open the concrete cover to a more rapid inflow of chloride.

- * A concrete will always contain water, that can become freezable if the temperature is low enough. Freezable water is also located to cracks, to coarse aggregate, to interfaces between aggregate and cement paste. Less than 10 litres of freezable water per m^3 of concrete might be sufficient to cause big internal damage. Therefore, even a dense concrete, with low water/cement ratio, needs a certain air-entrainment. The aggregate must have a very low porosity; $<1\%$.
- * The destruction increases with decreasing temperature. So for instance, a salt scaling test, with the minimum temperature -14°C , causes much less damage than a test with the minimum temperature -22°C . Thus, a freeze-test must be made with a minimum temperature that is representative of the climate in question.
- * The freezing rate has a rather small effect in itself. An increased freezing rate certainly increases the internal stresses in a test, which is made without moisture exchange between the concrete and the environment. The effect is however marginal. The most important effect of the freezing rate (and also of the duration of the test) is indirect, and is determined by the possibilities the freezing rate and duration gives the concrete to absorb or desorb water during freeze/thaw.
- * The concentration of salt solutions inside and outside the concrete is of major importance for the frost resistance. In a test, where there is no moisture exchange with the environment,

it seems as if a concentration of the pore solution in the neighbourhood of 2,5 % of NaCl is the most harmful; the pessimal. In a salt scaling test, where the solution is acting from the outside, on the surface, it seems as if mostly the outer concentration is of importance. The inner concentration is less important. The pessimal outer NaCl-concentration seems to be around 3%.

- * The average distance between the air pores is described by the Powers spacing factor. This is defined on the assumption that no air-pores become inactivated due to water absorption. In reality, a considerable portion of the air-pore system is water-filled already after a rather short time of water storage. The finer the air-pore system, the more rapid the water-filling. Therefore, theoretically, the Powers spacing factor cannot be used as a criterion for frost resistance. This has also been found in experiments. There are information in the literature of critical Powers spacing factors that vary from less than 0,16 mm to more than 0,6 mm. Normal values seem to be 0,18-0,20 mm, for freezing in the presence of deicing salts, and 0,25-0,30 mm, for freezing in pure water. The main reason for the big variation is that different tests, used for determining the critical Powers spacing factor, had different "degrees of wetness".
- * The true spacing factor is defined on the assumption that only air-pores, that are actually air-filled, should be regarded. Critical true spacing factors exist, no doubt, and they are considerably bigger than the normally stated values of the critical Powers' spacing factor; i.e. 0,18-0,30 mm, depending on whether freezing takes place in salt water or in pure water. The true spacing factor can, however, not be used for production control, due to the difficulties in its measurement. Determinations of the critical degree of saturation, as well as of the air-pore size distribution, are needed if a safe value shall be obtained.
- * The existence of a critical true spacing factor implies that there is a critical air content of the hardened concrete. This depends on the wetness of the environment; the wetter the environment, the bigger the portion of the air-pore system, that is inactivated due to water-filling, and the larger the required air content. Examples of how to calculate the required air content are given in the text.
- * The air content of the hardened concrete can be replaced by the air content of the fresh mix. This must be determined on a sample that is mixed, transported, cast, and compacted in a manner, that is representative of the concrete in the finished structure. The required "fresh" air content is determined by freeze-tests, and it is the major quality criterion to be used in the production of the concrete.
- * The Portland cement type is fundamental for frost resistance. It might be almost impossible to produce a concrete with a high salt scaling resistance with cements that have a high alkali content. Besides, other physical and chemical characteristics of the cement play a fundamental rôle. A suitable cement is selected on the basis of freeze-tests.
- * Mineral admixtures, such as fly ash, silica fume, and ground granulated blastfurnace slag, often reduce the frost resistance. This is not revealed in laboratory tests, but has been observed in field tests, where the concretes have undergone a natural ageing. Slag cements and the addition of fly ash shall be avoided. Small amounts of well-dispersed silica fume can be accepted.
- * The air-entraining agent, and the combination of the air-entraining agent and the water reducing agent, has a very big effect on the frost resistance. Many admixtures and admixture combinations produce concrete with very unstable and unsuitable air-pore systems. The admixtures shall be selected on the basis of freeze-tests.
- * Two types of freeze/thaw tests must be used:
 - a salt scaling test, revealing the salt scaling resistance of the surface
 - a freeze-test with pure water, revealing the internal frost resistance

A suitable salt scaling test is the Swedish method SS 13 72 44. For testing the inner frost resistance, the American Critical Dilation test, ASTM C671, or the Critical Degree of Saturation Test, is suitable. For all methods, the minimum freezing temperature might be lowered to $-22\pm 1^{\circ}\text{C}$.

- * Before production of the structure starts, a careful pre-testing of the salt scaling resistance, and the inner frost resistance, shall be made. By this, the mix proportions are fixed and the minimum air content of the fresh and hardened concrete is established. Principles for how this pre-testing can be made are given in the report
- * During production, tests of the fresh air content, the hardened air content and the salt scaling resistance shall be made. Principles for how this production testing can be performed are given in the report.

References

- Amsler; Eucker; Chamberlain [1973]: Techniques for measuring air void characteristics of concrete. Engineering Research and Development Bureau, New York State Department of Transportation, New York, 1973.
- Anonymous [1959]: Report on cooperative freezing-and-thawing tests of concrete. Highway. Res. Board, Special Report 47, Washington D.C. ,1959.
- Bager; Sellevold [1982]: Ice formation in hardened cement pastes- room temperature cured pastes with variable moisture contents. Building Materials Laboratory, Technical University of Denmark, Technical Report 118/82, Lyngby, 1982.
- Bonzel; Siebel [1977]: Neuere Untersuchungen über den Frost-Tausalz-Widerstand von Beton. Beton, Heft 4,5,6, 1977.
- Bremner; Carette; Malhotra [1989]: Role of supplementary cementing materials in concrete for the marine environment. In "Durability of Concrete -Aspects of admixtures and industrial by-products". 2nd Int. Seminar, Gothenburg June 1989. Swed. Council for Build. Res. Document D9:1989, Stockholm, 1989.
- Cordon [1966]: Freezing and Thawing of concrete- Mechanisms and Control. ACI Monograph No 3, 1966.
- Ewertson; Petersson [1992]: The influence of curing conditions on the permeability and durability of concrete. Part 2. The Swedish National Testing and Research Institute, SP Report 1992:51, Borås, 1992.
- Fagerlund [1975]: Significance of critical degrees of saturation at freezing of porous and brittle materials. American Concrete Institute. Publ. SP-47, Detroit, 1975.
- Fagerlund [1978]: Frost resistance of concrete with porous aggregate. Swedish Cement and Concrete Research Institute, Report Fo2:78, Stockholm, 1978.
- Fagerlund [1977A]: (i) "The critical degree of saturation method of assessing the freeze/thaw resistance of concrete", and, (ii) "The international cooperative test of the critical degree of saturation method of assessing the freeze/thaw resistance of concrete". Materials and Structures, Vol 10, No 58, 1977.
- Fagerlund [1977B]: Equations for calculating the mean free distance between aggregate particles or airpores in concrete. Swedish Cement and Concrete Research Institute, Report Fo 8;77, Stockholm, 1977.
- Fagerlund [1979]: Prediction of the service life of concrete exposed to frost action. In "Studies on concrete technology". Swedish Cement and Concrete Research Institute. Stockholm, 1979.
- Fagerlund [1982]: The influence of slag content on the frost resistance of the hardened concrete. Swedish Cement and Concrete Research Institute, Report Fo1.82, Stockholm, 1982.

- Fagerlund [1988]: Effects of air-entraining and other admixtures on the salt scaling resistance of concrete. In "Durability of Concrete. Aspects of Admixtures and other Industrial By-Products". Int. Seminar, Gothenburg, April 1986. Swedish Council for Building Research, Document D1:1988, Stockholm, 1988.
- Fagerlund [1990A]: Tele-tower Bergsjön Gothenburg- A service life estimate June 1990. Div of Building Materials, Lund Institute of Technology, Report U90.05, 1990 (In Swedish)
- Fagerlund [1990B]: Air-pore instability and its effect on the concrete properties. Nordic Concrete Research, Publ Nr 8, 1990.
- Fagerlund [1992]: Studies of the scaling, the water uptake and the dilation of mortar specimens exposed to freezing and thawing in NaCl-solution. In "Freeze-thaw and de-icing resistance of concrete", Div. of Building Materials, Lund Institute of Technology, Report TVBM-3048, 1992.
- Fagerlund [1993A]: The long time water absorption in the airpore structure of concrete. Div of Building Materials, Lund Institute of Technology, Report TVBM-3051, 1993.
- Fagerlund [1993B]: The critical spacing factor. Div. of Building Materials, Lund Institute of Technology, Report TVBM-7058, 1993.
- Fagerlund: [1994A] Influence of environmental factors on the frost resistance of concrete. Div of Building Materials, Lund Institute of Technology, Report TVBM-3059, 1994.
- Fagerlund [1994B]: Frost resistance of high performance concrete- some theoretical considerations. Div of Building Materials, Lund Institute of Technology, Report TVBM-3056, 1994.
- Fagerlund [1995]: The required air content of concrete. In the Proceedings of the International Workshop on Mass-Energy Transfer and Deterioration of Building Components. Paris January 9-11, 1995.
- Fagerlund; Janz; Johannesson [1993]: On the effect of frost damage on the bond between the reinforcement and the concrete. Div. of Building Materials, Lund Institute of Technology, Manuscript 1993. (In Swedish).
- Fagerlund; Somerville; Tuutti [1994]: The residual service life of concrete exposed to the combined effect of frost attack and reinforcement corrosion. Div. of Building Materials, Lund Institute of Technology, Manuscript to be presented at the BRITE/EURAM Conference "Concrete Across Borders" in Odense June 1994.
- Gebler; Klieger [1983]: First International Conference on Fly Ash, Silica Fume, Slag and other Mineral By-Products in Concrete. Proceedings Vol I, ACI Publication SP-79, Detroit, 1983.
- Ivey; Torrains [1970]: Air void systems in ready mixed concrete. J. of Materials, Nr 5, 1970.
- Larson; Cady [1996]: Identification of frost susceptible aggregate particles in concrete aggregates. National Cooperative Highway Research Program, Report 66, 1969.
- Lindmark [1993]: Effect of variations in salt concentration, salt distribution and freeze-thaw cycle at a salt scaling test according to the Swedish Standard SS 13 72 44. Div. of Building Materials, Lund Institute of Technology, Report M2:01, 1993.
- MacInnis, Lau [1971]: Maximum aggregate size effect on frost resistance of concrete. Journal of ACI, Proc. Vol 68, No 2, 1971.
- Malmström [1990]: Influence of the cement type on the frost resistance of concrete. The National Swedish Test Institute, SP-Report 1990:07, Borås 1990.
- Mielenz et al [1958]: Origin, evolution and effects of the airvoid system in concrete. 4 articles in ACI Journal 30(1958):2, 30(1958):3, 30(1958):4.

- Osborne; Rixom [1981]: A comparative study of PFA cements made by blending and intergrinding 5 and 20% ash. Int. Conf. on Slag and Blended Cements, Mons, 1981.
- Petersson [1986]: The influence of silica fume on the salt frost resistance of concrete. National Swedish Testing Institute, Technical Report 1986:32, Borås, 1986.
- Petersson [1993]: Functional testing of the frost resistance of concrete. In "The Service Life of Marine Concrete Structures". Danish Concrete Institute, Aalborg Portland, Cementa AB. Uppsala, 1993.
- Pigeon; Prévost; Simard [1985]: Freeze-thaw durability versus freezing rate. ACI Journal Sept-Oct, 1985.
- Pistilli [1983]: Air void parameters developed by air-entraining admixtures as influenced by soluble alkalies from fly ash and portland cement. ACI Journal, May-June 1983.
- Powers [1949]: The air requirement of frost resistant concrete. Proc. Highway Res. Board No29, 1949.
- Powers; Brownyard [1948]: Physical properties of cement paste. PCA. Bulletin 22, Chicago, 1948.
- Powers; Helmuth [1953]: Theory of volume changes in hardened portland cement paste. Proc. Highway Res. Board, No 32, 1953.
- RILEM [1995A]: Draft recommendations for test methods for the freeze-thaw resistance of concrete. Slab test and cube test. Materials and Structures, Vol 28, 1995, pp. 366-371.
- RILEM [1995B]: Draft recommendation for test method for the freeze-thaw resistance of concrete. Tests with water (CF) or with sodium chloride solution (CDF). Materials and Structures, Vol 28, 1995, pp. 175-182. (The method has been developed by Max Setzer at University of Essen.)
- Scrivener; Gartner [1987]: Microstructure gradient in cement paste around aggregate particles. In "Bonding in Cementitious Composites". Materials Research Society, Symposium Proceeding, Vol 114, Pittsburgh, 1987.
- Sellevoid [1990]: Frost resistance. Salt-frost scaling. Effect of test procedure and concrete composition. SINTEF-REPORT STF 65 A88090, Trondheim, 1990.
- Sellevoid; Farstad [1992]: Frost/salt testing of concrete. Effect of test parameters and concrete moisture history. Nordic Concrete Research, Publ. Nr 11, Oslo, 1992.
- Setzer; Auberg [1995]: Freeze-Thaw and Deicing Salt Resistance of Concrete Testing by the CDF Method. CDF Resistance Limit and Evaluation of Precision. Materials and Structures, Vol 28, 1995, pp. 16-31.
- Sommer [1978]: Ein neues Verfahren zur Erzielung der Frost-Tausalz-Beständigkeit des Betons. The Research Institute of the Association of Austrian Cement Manufacturers, Betonwerk+Fertigteile-Technik, Heft 9, 1978.
- Stark, Ludwig [1995]: The influence of the type of cement on the freeze-thaw/freeze-deicing salt resistance of concrete. In "Concrete Under Severe Conditions", Int. Conf. Sapporo, 1995. Proc. Vol 1, Spon, London, 1995.
- Vesikari [1988]: The effect of ageing on the durability of concrete including by-products. In "Durable Concrete with Industrial By-Products". Technical Research Centre of Finland, VTT Symposium 89, Espoo, 1988.
- Vuorinen [1973]: On determination of effective degree of saturation of concrete. Concrete and Soil Laboratory, Imatran Voima OY, Manuscript Oulo Finland, 1973.
- Wong; Anderson; Hilsdorf [1972]: The effect of drying on the freeze-thaw durability of concrete. Univ. of Illinois, College on Engineering. Engineering Experimental Station, Bulletin 506, 1972.