



LUND UNIVERSITY

Participating in Synchronous Online Education

Hrastinski, Stefan

2007

[Link to publication](#)

Citation for published version (APA):

Hrastinski, S. (2007). *Participating in Synchronous Online Education*. [Doctoral Thesis (compilation), Department of Informatics]. KFS AB.

Total number of authors:

1

General rights

Unless other specific re-use rights are stated the following general rights apply:

Copyright and moral rights for the publications made accessible in the public portal are retained by the authors and/or other copyright owners and it is a condition of accessing publications that users recognise and abide by the legal requirements associated with these rights.

- Users may download and print one copy of any publication from the public portal for the purpose of private study or research.
- You may not further distribute the material or use it for any profit-making activity or commercial gain
- You may freely distribute the URL identifying the publication in the public portal

Read more about Creative commons licenses: <https://creativecommons.org/licenses/>

Take down policy

If you believe that this document breaches copyright please contact us providing details, and we will remove access to the work immediately and investigate your claim.

LUND UNIVERSITY

PO Box 117
221 00 Lund
+46 46-222 00 00

Participating in Synchronous Online Education

Stefan Hrastinski

Department of Informatics

School of Economics and Management, Lund University

Department of Informatics
Ole Römers väg 6
S-223 63 Lund
Sweden

ISSN 1651-1816 Lund Studies in Informatics No. 6
ISBN 978-91-977186-1-5
© Stefan Hrastinski

Printed in Sweden
KFS AB Lund 2007

Abstract

There is an increasing need for education since the workforce of today is expected to be highly educated and continuously learn. Distance education is a powerful response to meet the growing need for education. *Online education*, here concisely defined as distance education mediated online, is the most common type of distance education. It mainly relies on asynchronous communication although it is well known that many students regard the lack of synchronous communication as disadvantageous. This thesis aims to achieve a deeper understanding of how, why and when synchronous communication, as a complement to asynchronous communication, affects *student participation* in online education.

In order to study the complex phenomenon of online student participation, various qualitative and quantitative data collection methods for assessing both *perceived participation* and *actual participation* were used. The aim was investigated in two offerings of an online undergraduate course and two series of online discussions on master level, and by conducting focus group interviews with experienced practitioners.

The findings indicate that synchronous communication has the potential to enhance *online student participation*. Light was shed on two dimensions of participation, which were labelled *personal participation* and *cognitive participation*. The thesis suggests that synchronous communication, as a complement to asynchronous communication, may better support personal participation. This is likely to induce arousal and motivation, and increased convergence on meaning, especially in smaller groups. Synchronous communication seems particularly beneficial for supporting task and social support relations, and to exchange information with a lower degree of complexity. By drawing on the studies of the thesis and previous research, propositions on when to support synchronous communication in online education were suggested.

This thesis has been supported by Jönköping International Business School and the Swedish Research School of Management and IT (MIT).

Acknowledgements

First of all I want to thank the two most important persons in my life! Thank you Eva for supporting me during my years as a PhD student. Without your daily love and support, writing this thesis would have been much harder and lonelier! My mother Stefica has worked hard to make it possible for me to pursue my interests and without her support I would never have become a Doctor of philosophy!

Thank you to my supervisors and friends, Sven Carlsson and Jörgen Lindh. Sven, I view you as a knowledgeable friend who has always given me advice after listening carefully to my point of view. You have also encouraged me in moving from a peripheral towards a full participant of the international research community. Jörgen, I have enjoyed our exciting discussions and joint work. You have given me confidence by telling me how great my work is almost every time we meet! Christina Keller co-authored three of the papers of the thesis and many other related publications. Even though you have not been my supervisor formally, you have promptly provided me with feedback of very high quality, which has improved this thesis!

I would like to thank my colleagues and fellow PhD students at Jönköping and Lund University, and in the Swedish Research School of Management and IT. I am very thankful to the Department of Informatics in Jönköping and the Swedish Research School of Management and IT for financial support of conference trips, research visits abroad and other activities. I would especially like to mention Carol-Ann Soames at Jönköping International Business School for letting me study your online course and for always giving me feedback on the English language and quality of my work so quickly!

Lars Svensson and Lisen Selander, acted as opponents on my half time seminar, and Urban Nuldén and Stefan Henningsson, acted as opponents on my final seminar. You all did a great job by providing constructive comments on how to improve the thesis. Lisen and Stefan have also provided me with feedback on my work many other times. I would also like to mention Pär-Ola Zander and David Sörhammar for giving me feedback on earlier drafts of papers in the thesis. Pär-Ola also helped me with practical issues regarding the thesis.

I had the privilege to spend half a year at Queensland University of Technology. Thank you Jason Watson and Allison Brown for making this productive and inspiring stay possible. I would also like to mention Sylvia Edwards and Shane Dawson for giving me feedback on an earlier draft of the thesis.

Thank you Urban Carlén and Ove Jobring for inviting me to participate in the vibrant community of research on online learning communities. In this community I met, among others, Jimmy Jaldemark – I have enjoyed our online discussions! Thank you to the senior researchers who have taken time to discuss my work – I would especially like to mention Caroline Haythornthwaite and Eva Fåhræus. Also, thank you Anneli Edman for support in the beginning of my research career and thank you Pär Ågerfalk and Birger Rapp for believing in my future potential as a researcher. Last but not least, thanks to all the students who have participated patiently in my research projects over the years!

Stockholm, November 2007

Stefan Hrastinski

Contents

1.	INTRODUCTION	1
1.1	Participation in online education	3
1.2	The context of online education	5
1.3	Aim and research questions	7
1.4	Technology-mediated learning and IS research	8
1.5	Structure of the thesis	11
2.	THEORETICAL BACKGROUND	15
2.1	On learning and participation	15
2.1.1	From objectivist to social theories on learning	15
2.1.2	Learning as participation in the social world	18
2.1.3	What is participation?	20
2.1.4	Participating in learning communities	21
2.1.5	Participating by using tools and reifying	22
2.1.6	Participating by collaborating	24
2.2	From distance education to online education	25
2.2.1	Three generations of distance education	26
2.2.2	Four types of interaction	29
2.2.3	Three types of exchanges	31
2.3	Computer-mediated communication	32
2.3.1	Asynchronous and synchronous communication	34
2.3.2	Studies on instant messaging	38
2.3.3	Theories on communication media	41
2.3.4	Computer-supported collaborative learning and work	43
2.4	Online student participation	45
2.4.1	What is online student participation?	46
2.4.2	Participation and related variables	47
2.5	Summary and conclusions	53

3.	RESEARCH ON ONLINE EDUCATION	55
3.1	Background to the literature reviews	55
3.1.1	Research design	56
3.2	Summary of Paper I and II	57
3.3	Analysis frameworks	59
3.4	Quality of the reviews	62
3.5	Summary and conclusions	63
4.	RESEARCH APPROACHES	65
4.1	Initial reflections	65
4.1.1	Ontological and epistemological reflection	65
4.1.2	Methodological reflection	66
4.1.3	From data to theory	67
4.2	Studying online student participation	70
4.2.1	Online student participation	70
4.2.2	Social network analysis	71
4.3	Case study research	74
4.4	Design science research	76
4.5	Research settings	78
4.6	Data collection	79
4.6.1	The process of data collection	81
4.7	Summary and conclusions	85
5.	SUMMARY OF THE EMPIRICAL AND DESIGN STUDIES	87
5.1	Paper III and IV	87
5.2	Paper V	89
5.3	Paper VI	90

6.	CONCLUDING DISCUSSION	93
6.1	Predicting online student participation	93
6.2	Predicting and explaining online student participation	94
6.3	Summarizing the empirical findings	99
6.4	Implications for design and practice	101
6.4.1	Synchronicity and learning outcomes	102
6.5	Influencing factors	106
6.5.1	Demographic factors	107
6.5.2	Behavioural factors	108
6.5.3	Contextual factors	110
6.5.4	Tentative implications on micro and macro levels	111
6.6	Quality of research design	113
6.6.1	Quality of empirical research	114
6.6.2	Quality of design research	116
6.7	Limitations and further research	117
6.7.1	Improving by reviewing	117
6.7.2	Theorizing on CMC artefacts	118
6.7.3	Measuring online participation	119
6.7.4	Participation over time	120
6.7.5	Participation by emerging media	120
6.8	Conclusion	121
	REFERENCES	123
	APPENDIX A: LIST OF ABBREVIATIONS	145
	APPENDIX B: RELATED PUBLICATIONS	147
	APPENDIX C: RESEARCH APPROACHES FOR STUDYING ONLINE STUDENT PARTICIPATION	151
	APPENDIX D: EXAMPLES OF IMPLICATIONS FOR PRACTITIONERS	153

The papers

PAPER I: An examination of research approaches that underlie research on educational technology: A review from 2000 to 2004

PAPER II: Computer-mediated communication in education: A review of recent research

PAPER III: The relationship between adopting a synchronous medium and participation in online group work: An explorative study

PAPER IV: Introducing an informal synchronous medium in a distance learning course: How is participation affected?

PAPER V: The potential of synchronous communication to enhance participation in online discussions

PAPER VI: An initial design theory for when to use synchronous communication in e-learning environments

1. Introduction

More than thirty years ago, Moore (1973) argued that there should be more emphasis on dialogue in distance education as a response to the physical and psychological isolation of learners. Online education, the currently most common type of distance education, mainly use delayed (asynchronous) means of communication (Romiszowski & Mason 2004) although it has been known for almost twenty years that most students regard the lack of spontaneous and real time (synchronous) communication as disadvantageous (Grint 1989). In this thesis it is examined how, why and when synchronous communication, as a complement to asynchronous communication, may affect student participation in online education.

There is an increasing need for education since the workforce of the “knowledge economy” is expected to be highly educated and continuously improve by engaging in life-long learning (The European Commission 2000). This has led to a dramatic increase in the number of students enrolled in higher education. Distance education has been argued to be one of the most powerful responses to meet the growing need for education (Gunawardena & McIsaac 2004). This type of education makes it possible for more people to take part in education, including those that cannot study on campus because they do not live close enough or have other commitments such as work and family.

Distance education has been a key factor in increasing the general education level. The number of students that study at a distance has increased dramatically (Gunawardena & McIsaac 2004; Rovai, Wighting & Lucking 2004). For example, in Sweden the number of distance students in higher education increased from 21,500 in 1993 to 80,896 in 2004 while the total number of students in higher education increased from 245,971 in 1995 to 331,062 in 2005. In 1993, 8.4% of the Swedish students studied at a distance. The relative degree of distance students had increased to 20.5% in 2005 (Swedish National Agency for Higher Education 2006).

Some have been concerned with the learning outcomes of distance students. However, research reveals that the learning outcomes of

students in traditional and distance education settings are equal. In a review of 355 research papers, Russell (2001) concluded that there is no significant difference in learning outcomes, commonly measured as grades or exam results, between these two modes of delivery. Moreover, a retrospective discussions of distance education provides more than a century of success stories of this type of education (Mårtensson, Larsson & Bergsten 1998).

The enrolments in distance education have increased dramatically and the learning outcomes of students in this setting seem equal to that of “traditional” education. What then are the drawbacks of distance education? A low retention rate seems to be the major concern (e.g., Carr 2000; Lake 1999; Rovai et al. 2004). Anecdotal evidence suggests that retention rates of distance education vary between 50 and 80%, which is about 10 to 20% lower when comparing with traditional education (Carr 2000). In 2006, the retention rate for Swedish online courses, i.e. distance education courses mediated online, was 59%. However, the retention rates differed considerably when comparing universities, from 26% at Stockholm University to 81% at Karolinska Institutet (Forsberg 2007). The key reason for not completing online courses is lack of time, because of family and work commitments, and enrolment in other programs or courses (Westerberg & Mårald 2006).

Low retention rates do not only affect students and teachers personally but also have economic consequences for educational organizations (Lake 1999). The income of universities depends on the number of enrolled students and when students only complete part of a program this results in loss of income. Moreover, educational technologies are costly to develop and implement, especially if only used by few. One reason for the high levels of withdrawal from distance education is that learners often identify themselves as peripheral rather than full participants (Lave & Wenger 1991). According to Lake (1999), both physical and psychological isolation may occur:

Physical isolation is composed of geographical isolation from resources, whether those resources are material or human, and temporal isolation, where the delay between stimulus from the student and response from the institution is sufficiently great to retard communication. Isolation can also take the form of psychological isolation where the student feels segregated from the tutor, and thereby

the content and administrative help that could be supplied by the tutor, and from peers who could provide support. (p. 16)

As stated above, the issue of isolation has been acknowledged for more than thirty years (Moore 1973). In fact, Moore and Kearsley (1996) argue that the single important issue of distance education is to encourage students to participate actively, despite being geographically dispersed.

1.1 Participation in online education

It is commonly suggested that *student participation* in distance education can be enhanced by using computer-mediated communication (CMC¹) media (e.g., Harasim 1989; Haythornthwaite & Kazmer 2002; Leidner & Jarvenpaa 1995). In this thesis, Wenger's (1998) definition of participation, "a process of taking part and also to the relations with others that reflect this process" (p. 55), has been consistently used. Computer technologies, such as CMC, enable participation in many-to-many learning approaches, which motivates why the term *online education* has been introduced to describe this new type of distance education (Harasim 1989). Online education is the most common type of distance education in Sweden. In 2005, 70% of the distance students were enrolled in online education (Swedish National Agency for Education 2006).

The move from distance education towards online education has occurred during the same time that it has become more widely recognized that information technology (IT) matters in organizations. By analysing the last four decades, Dhar and Sundararajan (2007) identified three main consequences that are likely to hold for IT in organizations in the foreseeable future. One of these is "a growth in society of the importance and variety of 'spaces of interaction' that are mediated by IT" (pp. 130-131). Fortunately, online education and other types of technology-mediated education give students experience of how IT can be used as support for interaction and collaboration.

¹ A list of abbreviations is included in Appendix A.

Research on online education is an emerging research area. About ten years ago, Moore and Kearsley (1996) wrote that interaction between learners is “a relatively new dimension for teachers in distance education” (p. 131). CMC in education has received increased attention from research lately. For example, five Swedish doctoral theses that mainly studied interaction between students have been published recently: Svensson (2002) aimed to “understand and support IT-mediated communities of distance education” (p. iii), Wännman Toresson (2002) studied “women’s participation in two different kinds of computerized further education” (abstract), Fåhræus (2003) focused on “collaborative learning and how it can be applied and supported in distance education” (abstract), Björck (2004) investigated “the use of problem-based learning in online courses” (p. 1), and Malmberg (2006) examined “students’ dialogue and collaboration when working in small groups in a netbased course” (abstract). These theses have been published in different academic disciplines – informatics, educational science and computer and systems science. Thus, researchers in this area have various formal affiliations although they share a similar interest.

There are probably many ways CMC media can be used to support online student participation. Hitherto, the use of CMC in online education has been mainly asynchronous, which has been argued to make collaboration difficult (Fidas et al. 2006). However, “recent rapid improvement in technology and the increasing bandwidth and access in most parts of the world have led to an increasing popularity of synchronous solutions for instruction” (Kinshuk & Chen 2006). The second paper of the thesis presents a literature review on research on CMC in education. It indicates that most research has been focused on asynchronous communication, often by studying the use of discussion boards. This conclusion is supported by Romiszowski and Mason (2004) who call for more research on synchronous communication.

This thesis complements previous research by shedding light on how, why and when synchronous communication, as a complement to asynchronous communication, affects student participation in online education. Many teachers are already supporting asynchronous communication, by e-mail and discussion boards, but these methods are often not sufficient (Schullo et al. 2005). There is a need to guide

teachers, administrators, managers and developers of online learning environments who are considering using or implementing synchronous communication. The need of support is becoming increasingly urgent as the use of CMC continues to grow in education settings (Olaniran 2006). Early adopters have used synchronous CMC for many years but it can be anticipated that most practitioners of education will have to decide how, why and when to use this type of communication as it becomes increasingly common in educational settings (Kinshuk & Chen 2006).

Researchers can contribute towards a deeper understanding of synchronous communication by investigating how various variables, such as learning outcomes, retention rates and student satisfaction, are affected as a consequence of communicating synchronously. In this thesis, the variable of choice is participation. Student participation has been shown to affect learning outcomes positively (Fredericksen et al. 2000; Hiltz et al. 2000). In these studies, learning has been measured as perceived learning, grades and quality assessment of assignments. Furthermore, it has been argued that participation positively influences student satisfaction (Alavi & Dufner 2005) and retention rates (Rovai 2002). More thorough reviews of these relationships are discussed in section 2.4.2.

1.2 The context of online education

Typically, online education occurs in an *online learning environment*, such as WebCT, Moodle or Blackboard. Figure 1.1 shows a screenshot of WebCT, which was used in a case study of Paper V. Typical features of such environments include management of course content, administrative issues, communication among students and teachers, evaluation, and assessment (Keller 2007). Examples of features in the screenshot include private mail (Swe. "privat post"), discussion board (Swe. "diskussioner"), chat (Swe. "chatt"), calendar (Swe. "kalender"), information about library resources (Swe. "biblioteket") and course material for various courses. It should be acknowledged that WebCT only provides the tools – it is the teacher and the educational institution that decide how to use the tools to support educational activities.

The course that was studied was “Change and Knowledge Management” and by accessing that icon, course contents are listed. In this thesis, CMC has been given special attention and various means of CMC have been studied, including discussion board, chat and instant messaging². In the case study of Paper V, where WebCT was studied, the focus was on the use of discussion board and chat – the other features were not studied.

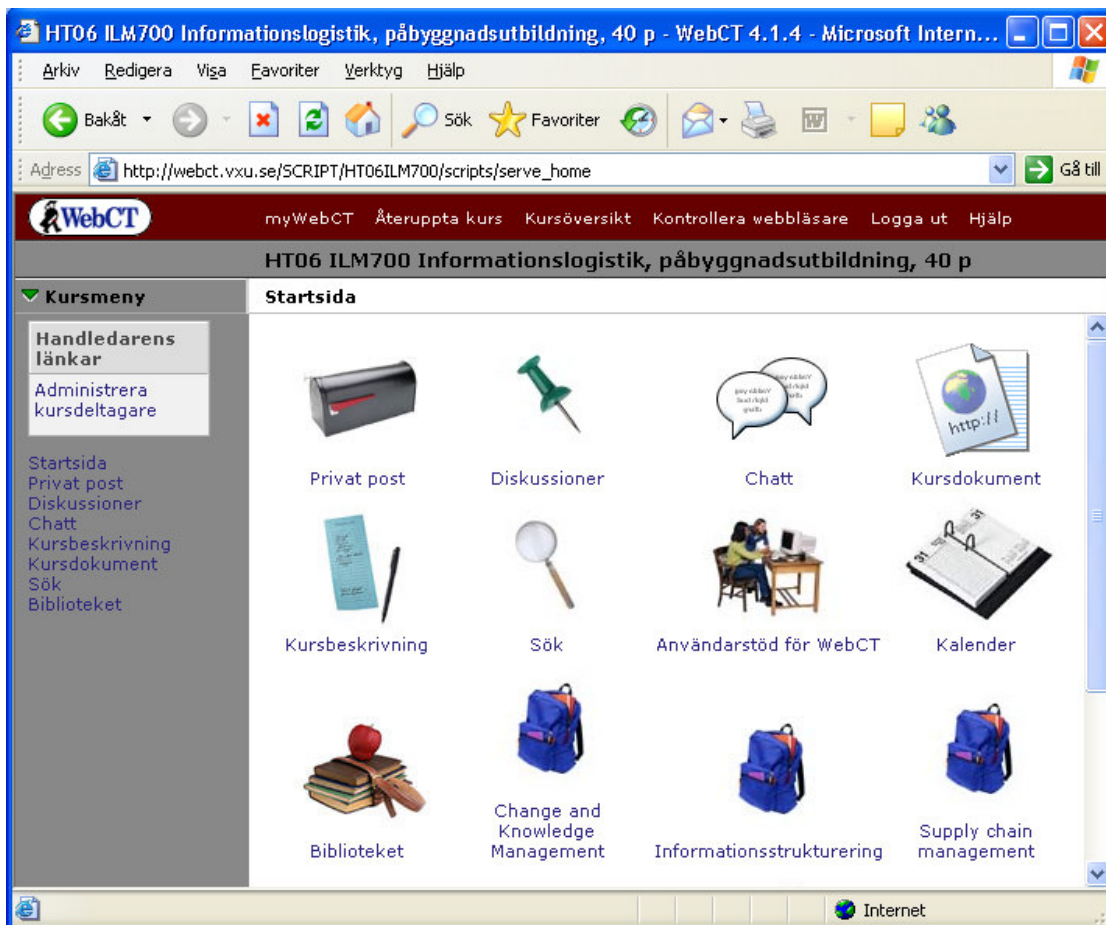

Figure 1.1. A screenshot of WebCT, an online learning environment

² IM can be used to communicate with people on a list of “friends”. It differs from chat since users can be contacted spontaneously when they are online, e.g., meetings do not need to be scheduled.

In the context of online education, CMC media are commonly used to enable communication among students and teachers, ranging from private to class-wide communication. For example, in the online courses that have been studied in this thesis, students privately asked each other and the teacher questions, small groups of students communicated in project groups and the students discussed literature with the teacher in class-wide online seminars. These different types of communication have been studied as part of the empirical studies of the thesis.

1.3 Aim and research questions

The aim of the thesis is to contribute towards an understanding of how, why and when synchronous communication, as a complement to asynchronous communication, affects student participation in online education. Two literature reviews (Paper I and II) were conducted prior to identifying the aim. These reviews provide an overview of the research approaches and key topics of the field of online education and underlie the choice of research topics and approaches for the thesis.

RQ1-2: Which research approaches and topics underlie research on online education? Which might the implications be for further research? (Paper I and II)

The aim of the thesis has been addressed by formulating five research questions. As discussed above, CMC can be used to support different types of activities, ranging from private to class-wide communication. The first three questions focus on how the possibility to communicate synchronously may affect student participation in three settings: group work, in online discussions and in an online course in general. The research questions are motivated more thoroughly in the papers.

RQ3: How does the possibility to communicate synchronously via an IM system affect student participation in online group work? (Paper III)

RQ4: How does the possibility to communicate synchronously via an IM system affect student participation in an online course?³ (Paper IV)

RQ5: How may the possibility to communicate synchronously via chat, as a complement to asynchronous communication by discussion board, affect student participation in online discussions? (Paper V)

At first, the focus of the thesis was on *how* synchronous communication affects student participation. However, in order to better understand the complex relationship between synchronous communication and participation, the remaining research questions investigated *why* and *when* synchronous communication may affect student participation. The sixth research question expands on the findings of the empirical studies by investigating why synchronous and asynchronous enable different types of participation.

RQ6: Why may synchronous and asynchronous communication enable different types of participation in online education? (Chapter 5)

The findings of the empirical studies guided the final paper, which presents design propositions for when to support synchronous communication, as a complement to asynchronous communication, in online education.

RQ7: When may synchronous communication be supported as a complement to asynchronous communication in online education? (Paper VI)

1.4 Technology-mediated learning and IS research

The IS field is often described as a fragmented discipline characterized by paradigmatic and methodological diversity (Hirschheim & Klein 2003). Prior to tackling the aim and research questions of this thesis, I will motivate why the topic of this thesis is of importance to the IS

³ In this paper, the term *distance learning course* was used, but as motivated above I nowadays prefer the term *online course*, which better describes the specific type of course that was studied, i.e. a course mediated online.

community and provide examples of IS research on technology-mediated learning.

During the recent decades, the field of distance education has experienced considerable change. It has developed from correspondence education relying on print based materials towards using a variety of technologies. Nowadays, 94% of administrators choose computer technology as the preferred mode of delivery (Kambutu 2002). Educational researchers have argued that technology is “one of the most important forces behind the increased use and extended scope of distance education” (Lindberg & Olofsson 2005, p. 16). Garrison (2000) contends that the challenge for the new century is to “provide an understanding of the opportunities and limitations of facilitating teaching and learning at a distance with a variety of methods and technologies” (p. 13). This shift towards online education motivates why issues ranging from learning theory to software engineering need to be addressed to support the development and evaluation of emerging technology-mediated learning environments (Mor & Winters 2007). Disciplines less focused on technology, such as educational science, play an important part in research on online education but there should be no doubt that it has become an interdisciplinary science. Thus, contributions from various research disciplines are needed.

Alavi and Leidner (2001b) have written a research commentary where they argue that technology-mediated learning is of importance to the IS community. They believe that such research will continue to increase in importance because of the emerging knowledge society, in which the need for life-long learning is emphasized. This changes the need for education because of the increasing demand for a highly educated workforce who will be expected to learn continuously.

Unfortunately, there is “a paucity of theoretically grounded and rigorous research to guide the development of [technology-mediated learning] environments” (Alavi & Leidner 2001b, p. 2). Supporting these arguments, research on CMC in education has been criticized as being too anecdotal (Mazzolini & Maddison 2003; Romiszowski & Mason 2004). Thus, there is a need for research that not only is relevant for practice but also relies on rigorous methods and is theoretically grounded.

Alavi and Leidner (2001b) mention three reasons why the IS field is uniquely positioned to contribute to the development of technology-mediated learning:

First, the IS field has a history and tradition of research and development that involves the application of information technologies to cognitive processes (e.g., decision making and problem solving). ... Secondly, based on a long tradition of research in the appropriate structures and processes to enhance information systems success, ... IS researchers can offer organizational level vision on structures and processes to effectively implement [technology-mediated learning] initiatives. Thirdly, given that technology can be both an enabler of, or hindrance to, innovation in education, IS scholars can deploy their knowledge of information technologies to help determine appropriate instructional applications. (pp. 2-3)

The IS field includes research streams such as knowledge management, computer-supported cooperative work and information system evaluation, and typically draw upon other, more fundamental, reference disciplines (Baskerville & Myers 2002). Consequently, IS researchers may be able to integrate the different theoretical perspectives that are needed in the interdisciplinary research area of technology-mediated learning.

Swedish IS researchers, which are mainly found at informatics, and computer and systems science departments, have been conducting research on technology-mediated learning for almost thirty-five years. The Swedish interest in technology-mediated learning dates back to early innovators at the Department for Computer and Systems Sciences at Stockholm University and the Royal Institute of Technology. For example, computer-supported examination was developed and evaluated in the late 1960s (Kollerbauer, Köhler & Yngström 1973; Ohlin 2006).

In the 1980s, Köhler (1981) finished his thesis where a methodology for computer-supported teaching was developed. More than a decade later, Lindh's (1993) thesis on the possibilities and problems associated with computer-supported teaching was published. Since 1999, at least six theses have been written by IS researchers, two of which were mentioned above (Fåhræus 2003; Svensson 2002). The remaining ones have been focused on information technology use in higher education

(Nuldén 1999), technology-support for learning construction skills (Tholander 2003), the development of expertise and language use in technology-supported learning environments (Karlgrén 2003) and user acceptance of virtual learning environments (Keller 2007).

Swedish IS researchers have conducted research related to technology-mediated learning for a long time, although the review above reveals that the interest has increased considerably since the end of the 1990s. Research on technology-mediated learning has received considerable attention internationally as well. For example, journals that are highly regarded among IS researchers, such as *MIS Quarterly*, *Information Systems Research* and *Communications of the ACM* have included publications on the topic (e.g., Alavi, Marakas & Youngjin 2002; Piccoli, Ahmad & Ives 2001; Zhang et al. 2004). Recently, the IS Education and Teaching Cases track of the International Conference on Information Systems (2007) called for research on the topic.

1.5 Structure of the thesis

In the first part of the thesis, the research is discussed and analysed more broadly than was possible in the individual papers. In the next chapter, a theoretical background is presented. In chapter three, the literature reviews of Paper I and II are summarized and discussed. Then, the research approaches that underlie the empirical and design studies of Paper III-VI are discussed. In chapter five, the empirical and design studies are summarized. The last chapter includes a discussion of the major findings and their implications. It includes retrospective assessments of the quality of the research and opportunities for further research. On the next two pages, the papers of the thesis are introduced. Related publications are listed in Appendix B.

Paper I

Hrastinski, S., & Keller, C. (2007). An examination of research approaches that underlie research on educational technology: A review from 2000 to 2004. *Journal of Educational Computing Research*, 36(2), 175-190. An earlier version of this paper was included in the Proceedings of the 3rd Netlearning Conference, 2006, Ronneby.

The paper reviews the research approaches that underlie research on educational technology.

Paper II

Hrastinski, S., & Keller, C. (2007). Computer-mediated communication in education: A review of recent research. *Educational Media International*, 44(1), 61-77. An earlier version of this paper written by the first author was included in the Proceedings of the 17th World Conference on Educational Multimedia, Hypermedia and Telecommunications (Ed-Media), 2005, Montreal.

The paper reviews the methodologies that underlie research on CMC in education and the research topics that have been addressed.

Paper III

Hrastinski, S. (2006). The relationship between adopting a synchronous medium and participation in online group work: An explorative study. *Interactive Learning Environments*, 14(2), 137-152. An earlier version of this paper was included in the Proceedings of the 17th World Conference on Educational Multimedia, Hypermedia and Telecommunications (Ed-Media), 2005, Montreal.

The paper evaluates how the use of an IM system affects student participation in online group work.

Paper IV

Hrastinski, S. (2006). Introducing an informal synchronous medium in a distance learning course: How is participation affected? *The Internet and Higher Education*, 9(2), 117-131. An earlier version of this paper was

included in the Proceedings of the 22nd Conference of the Australasian Society of Computers in Learning in Tertiary Education (ASCILITE), 2005, Brisbane.

The paper evaluates how the use of an IM system affects student participation in an online course.

Paper V

Hrastinski, S. (2007). The potential of synchronous communication to enhance participation in online discussions. Proceedings of the *28th International Conference on Information Systems*, Montreal.

The paper examines how the possibility to communicate synchronously by chat, as a complement to asynchronous communication by discussion board, affects student participation in online discussions.

Paper VI

Hrastinski, S., Keller, C. & Carlsson, S. A. (2007). An initial design theory on when to support synchronous communication in e-learning environments⁴. Submitted for publication. Earlier versions of parts of this paper were included in the Proceedings of the *15th European Conference on Information Systems*, 2007, St Gallen, and the *2nd International Conference on Design Science Research in Information Systems and Technology*, 2007, Pasadena. The paper was nominated for the Herbert A. Simon award for the best research paper at the latter conference.

The paper suggests design propositions on when to support synchronous communication, as a complement to asynchronous communication, in online education.

⁴ In this paper, the term *e-learning* was used since we wanted to publish the paper in a mainstream IS journal, and the term is commonly used among IS researchers. However, as was motivated in the introduction, the term *online education* has been preferred in this thesis because it describes a specific type of e-learning, i.e., distance education mediated online.

2. Theoretical background

In the next section, theoretical perspectives on learning and participation that underlie the thesis are discussed. The second section describes the change from distance education towards online education. Then, research on the use of CMC in education is reviewed. The final section focuses on participation in online education settings, which commonly is enabled by using CMC media. Finally, the chapter is summarized and a model of online student participation and related variables is suggested.

2.1 On learning and participation

There are many different theoretical perspectives on learning although it has been acknowledged that many of the theories that have emerged during the 1990s share many assumptions and common foundations (Jonassen & Land 2000). Nowadays, most researchers agree that knowledge not only exists in individual minds but also “in the discourse among individuals, the social relationships that bind them, the physical artefacts that they use and produce, and the theories, models and methods they use to produce them” (Jonassen & Land 2000, p. vi). Here, special attention will be given to social theories on learning, which view learning as participation in the social world. Then, the concept of participation and its relationship with other concepts is discussed.

2.1.1 From objectivist to social theories on learning

Computer-supported learning has traditionally been based on *objectivist* theories on learning. The objectivist tradition assumes that knowledge is an object that can be absorbed by students (Duffy & Jonassen 1992). This assumption originates from the psychological school of behaviourism. The key theory of behaviourism was that of stimuli and

response, where stimuli, and combinations of stimuli, were argued to determine reactions (Watson 1925/1997). The aim was “to be able to reproduce [a] reaction at another time (and possibly in other individuals as well)” by determining “what the situation is that causes this particular reaction” (ibid, p. 20). The behaviourist school inspired many decades of research, which aimed to understand and predict human behaviour (e.g., Skinner 1974).

When applying ideas originating from the objectivist tradition, the goal of the teacher becomes to transfer “knowledge objects” to students and for students to recall the knowledge (Duffy & Jonassen 1992; Leidner & Jarvenpaa 1995). The student should gain a complete and correct understanding and, ideally, all students of a class will eventually achieve identical understandings (Duffy & Jonassen 1992). What students learn can be improved if teachers communicate more effectively and clearly to students (Jonassen & Land 2000). Prior experiences and human interpretation is not of interest since it is seen as leading to partial and biased understandings (Duffy & Jonassen 1992). Technology is used to transmit instruction with limited possibilities for conversations with teachers and peers (Edelson, Pea & Gomez 1996).

In the beginning of the 1990s, *constructivist* theories on learning gained popularity. The argument of constructivism is that there is no correct “meaning” of the world that we are striving to understand. Instead, it is argued that there are many ways to structure the world, and there are many meanings or perspectives for any event or concept (Duffy & Jonassen 1992). Individually oriented constructivist models assume that the main objective of teachers should be to support students in gaining experiences rather than aiming to transfer “knowledge objects” from the teacher to the learner (Säljö 2000). Thus, constructivist theories have moved away from the knowledge transmission model towards an active learner model. However, like objectivism, constructivism has “commonly focused on the learner as an individual, learning in isolation from other learners” (Edelson et al. 1996, p. 151).

The view on learning in this thesis is especially inspired by *sociocultural* learning theory (Säljö 2000; Vygotsky 1978) and Wenger’s (1998) theory of *learning as social participation*. These two perspectives seem to agree upon the social nature of learning. In the sociocultural tradition, the

term culture is used to describe knowledge and other resources that exist within the individual, in social interaction and in tools (Säljö 2000). Wenger emphasizes participation, which he refers to as “a process of taking part and also to the relations with others that reflect this process” (p. 55). The two perspectives will hereafter be jointly referred to as *social theories on learning*. Such theories emphasize that learning is dialogue, both internal and by social negotiation (Fåhræus & Döös 2006; Jonassen & Land 2000). Rather than being solely based on experience with the physical world, the construction of knowledge and understanding is seen as a fundamentally social activity (Littleton & Häkkinen 1999, p. 24). There exists different perspectives but the most common ones share a focus on participation as a condition for learning (Jaldemark, Lindberg & Olofsson 2006). This perspective is further discussed in the next section.

Table 2.1. Perspectives on learning (adapted from Leidner & Jarvenpaa 1995)

Perspective	Basic premise	Major implication
Objectivist	Learning occurs by absorbing objective knowledge.	Teachers should transfer knowledge to students.
Constructivist	Learning occurs by constructing knowledge individually.	Teachers should support rather than direct students.
Social	Learning occurs by participating in the social world.	Teachers should encourage participation and relations among students.

The basic premises and implications of the three theoretical perspectives on learning that have been discussed are summarized in Table 2.1. It is commonly distinguished between adopting a *surface approach* to learning, where “learners are focusing on surface characteristics of the situation”, and a *deep approach* to learning, where “learners are focusing on the object of learning, [and] are trying to get hold of the phenomenon dealt with” (Bowden & Marton 1998, p. 8; Marton et al. 1977). These approaches are related with what students feel is required of them by the educational institution. While the practice and assessment of objectivist approaches focus on surface characteristics, constructivist and social approaches seem to have greater potential to induce deep approaches toward learning.

It is sometimes argued that the constructivist and social perspectives are complementary, and that the two types of theories inform each other. Scholars have questioned the need to take sides between constructivist and social perspectives (Cobb 1994; Sfard 1998). Cobb argues that the “sociocultural perspective informs theories of the conditions for the possibility of learning, whereas theories developed from the constructivist perspective focus on what students learn and the processes by which they do so” (p. 13). The focus on social theories on learning in this thesis led to studying learning as participation in a social context. However, studying participation from, for example, constructivist perspectives would probably provide complementing insights (Jaldemark, Lindberg & Olofsson 2005).

2.1.2 Learning as participation in the social world

Learning as participation in the social world is at the core of Lave and Wenger’s (1991) theory of learning, a theory that is further elaborated on in Wenger (1998). Social learning theories stress that learning occurs in interaction with others and that learning is an aspect of all human activities (Säljö, 2000). Such theories have been commonly used in recent research. For example, recent doctoral theses on online education have drawn upon Wenger’s social theory of learning as social participation (Lindberg & Olofsson 2005; Svensson 2002) and sociocultural theory on learning (Björck 2004; Fåhræus 2003; Malmberg 2006; Wännman Toresson 2002).

Social learning theories advocate that learning and participation are not separate activities that can be turned on and off (Wenger 1998). Thus, students are not students just while they are in the classroom. It is widely acknowledged that students learn and support each other both inside and outside the classroom (Brown & Duguid 1996; Rovai et al. 2004). In fact, Ramsden (1992) argues that “[m]ost learning in higher education goes on outside the lecture room” (p. 154). Learning is viewed as “embedded within and inseparable from the day-to-day practices that people carry out in the conduct of their work [and studies]” (Hislop 2006, p. 5).

Addressing weaknesses of social perspectives on learning

Like any other theoretical perspective, social perspectives on learning are associated with weaknesses. Hislop (2006) argues that a typical weakness of empirical studies from the perspective of practice based epistemologies is that they pay more attention to micro-level factors, which suggest that the perspective may be less useful for studying wider factors.

As will be discussed in the next section, Wenger (1998) argues that viewing learning as participation in the social world has a broader focus than merely encouraging communication among students. However, in research simple measures are commonly used. For example, participation in online discussions is often assessed by using quantitative measures such as how many messages the students have posted in a discussion board (e.g., Arbaugh 2000; Mazzolini & Maddison 2003). Romiszowski and Mason (2004) argue that there is an assumption in research, which seldom is challenged, that infrequent contributors are “passive recipients rather than actively engaged in learning” (p. 399). Much reading is not passive since it may encompass engagement, thought and reflection. This is reflected by two of Kolb’s (1984) four basic learning modes: abstract conceptualisation, which emphasizes thinking, and reflective observation, which emphasizes understanding. A central argument of this thesis is that relying solely on simplistic quantitative measures of participation is not sufficient.

As has been argued elsewhere (e.g., Garrison & Anderson 2003; Lindh, Hrastinski & Soames 2005, 2006) and has been found in the empirical studies of this thesis, it is common that online students prefer to work individually. It has also been argued that some education programs encourage individual rather than collaborative learning. An explanation is that teachers and students often view participation with others as aspects of well-being rather than learning (Olofsson & Lindberg 2006). Thus, although most contemporary learning theories suggest that interactions with peers and teachers enhance, or as a prerequisite to, learning (Jonassen & Land 2000), it seems that some practitioners would not agree. Researchers need to be aware of this paradox when studying student participation.

2.1.3 What is participation?

Participation is not a new concept – already the Greeks used it to describe decision taking. A decision was participatively taken if more or less everybody agreed (Mumford 1983a). In this thesis, I have consistently drawn on Wenger’s (1998) conceptualisation of *participation*⁵. His definition falls within common use as exemplified by Webster’s definition: “To have or take a part or share with others (in some activity, enterprise, etc.)”. Wenger refers to participation as “a process of taking part and also to the relations with others that reflect this process” (p. 55). It is a complex process that combines doing, talking, thinking, feeling and belonging. Participation involves action, e.g., talking with someone, and connection, e.g., feeling that one takes part. Wenger’s conceptualisation of participation is broader than that of the Greeks but there is some resemblance. He describes participation as the possibility of mutual recognition: When we engage in a conversation we shape each other’s experiences of meaning, which, for example, may lead to a joint decision.

Participation occurs on both personal and social levels. Thus, it should be clarified that we may participate socially even at times when we are not engaged in a conversation with someone:

From [Wenger’s] perspective our engagement with the world is social, even when it does not clearly involve interactions with others. Being in a hotel room by yourself preparing a set of slides for a presentation the next morning may not seem like a particularly social event, yet its meaning is fundamentally social. Not only is the audience there with you as you attempt to make your points understandable to them, but your colleagues are there too, looking over your shoulder, as it were, representing for you your sense of accountability to the professional standards of your community. A child doing homework, a doctor making a decision, a traveler reading a book – all these activities implicitly involve other people who may not be present. (Wenger 1998, p. 57)

⁵ The use of participation here should not be confused with the research field of “participative systems design”, which is “a methodology to involve users at all levels in the design of new technical and work systems” (Mumford 1983b, p. 47).

The quote above illustrates the complexity of analysing student participation when departing from social theories on learning. It illustrates that participation is not tantamount to, for example, talking, writing or collaborating, an argument that is further developed in the next sections.

2.1.4 Participating in learning communities

Wenger's (1998) definition of participation partly overlaps with what is referred to as *sense of community* in the literature. In fact, some have described participation as belonging to a community (Jaldemark et al. 2006). In a review that includes definitions of community, Rovai (2002) identified the most essential elements of community: "mutual interdependence among members, sense of belonging, connectedness, spirit, trust, interactivity, common expectations, shared values and goals, and overlapping histories among members" (p. 4). A difference from Wenger's definition of participation is that Rovai only uses positive terms when describing sense of community. Wenger, however, has acknowledged that participation in a community involves all kinds of relations, i.e. "conflictual as well as harmonious, intimate as well as political, competitive as well as cooperative" (Wenger 1998, p. 56). It is clear that participation and sense of community are related, although the similarities and differences between the concepts will need to be further explored in future research.

In Paper III it is argued that participating in and feeling attached to a group, which is a central aspect of sense of community, are dual processes. People who have a strong attachment to a group are more likely to participate and help others. Conversely, participating and helping others drive group attachment (Wellman & Gulia 1999). Likewise, Palloff and Pratt (2005) have argued that collaboration and community are dual processes. Thus, when evaluating participation the importance of group attachment should not be forgotten.

The term *learning communities* is also commonly used in the literature and has been defined as "a limited number of people who share common goals and a common culture" (Johnson & Johnson 1999, p. 180). Palloff and Pratt (2005) have described the relationship between community and collaboration as cyclical: "collaboration supports the

creation of community and community supports the ability to collaborate” (p. 5). Learning communities work together, learn from each other and from the surrounding culture and environment (Wilson 1996). The term *online learning communities* underscores that learning communities may, and often are, mediated online (Carlén & Jobring 2005).

Another influential concept is that of *knowledge-building communities*, which accentuates that the purpose of learning communities should be to increase the collective knowledge by contributing beyond what is already known (Scardamalia & Bereiter 1996). The benefits of participation in learning communities can also be understood through the concept of *collective consciousness* in learning. The term is defined as “an awareness of others’ ways of seeing things, as linking individual consciousnesses to each other” (Bowden & Marton 1998, pp. 14-15). According to Bowden and Marton, students learn from other students as well as learning from the teacher by becoming aware of other peoples’ views of various phenomena.

Factoring the above, the concepts of sense of community, learning communities, knowledge-building communities and collective consciousness in learning are closely related with Wenger’s (1998) definition of participation. However, it was acknowledged that this relationship is complex and depends on how each of the concepts is defined. Moreover, participation might include conflictual and competitive relations (Wenger 1998), while such relations were not mentioned in the definitions reviewed above.

2.1.5 Participating by using tools and reifying

Throughout the history of technological developments, humans have been creating technologies that have changed how we communicate and use intellectual resources (Säljö 1999). A recent technology that has made it possible to communicate over a distance easier, quicker and cheaper, often by exchanging text, is CMC. Säljö (1999) argues that people learn by making use of artefacts and opposes traditional approaches to understanding learning, which “treat knowledge and skill as if people were not operating with tools when solving problems and when managing social activities” (p. 149). Vygotsky (1978)

distinguished two types of tools, *physical* and *psychological tools*. In most situations, physical tools (e.g., computer) help people to accomplish their goals. Psychological tools (e.g., language) are usually used together with physical tools. For example, when using a computer connected to the internet with appropriate software (physical tool) it is possible to communicate with others by using language (psychological tool).

A process in which both physical and psychological tools may be utilized is *reification*. It is defined as “the process of giving form to our experience by producing objects that congeal this experience into ‘thingness’” (Wenger 1998, p. 58). Wenger argues that participation and reification cannot be considered in isolation since the concepts are complementary. For example, participation makes up for the inherent limitations of reification (e.g., students discuss what they read to compare and enrich interpretations) and vice versa (e.g., students share notes when they cannot attend a seminar). Examples of processes of reification include “making, designing, representing, naming, encoding, and describing as well as perceiving, interpreting, using, reusing, decoding, and recasting” (ibid, p. 59). Examples of the productions of these processes include “abstractions, tools, symbols, stories, terms, and concepts” (p. 59). Thus, educational design is not just about reification but also about designing for participation (Wenger 1998). Reification can be considered as the product of participation.

Language and communication are prominent features of human knowledge and learning: “to a significant extent [knowledge] is created in such interactions when we convert our experiences and reflections into language and make them public” (Säljö 1999, p. 150). By using language, humans have a unique way of sharing experiences with each other. An influential concept within the sociocultural school is the Zone of Proximal Development (Vygotsky 1978). It emphasizes that by interacting with someone who is more experienced, such as a teacher or a more skilled peer, someone can complete more advanced tasks and, thus, learn or develop more than she could have done by herself. “We can ask others, and we constantly borrow and exchange information, knowledge and skills in interaction with others” (Säljö 2000, p. 34, my translation). Thus, the language is the link between the external (communication) and the internal (thinking) (Säljö 2000).

Traditionally, the importance of interaction has often been neglected in correspondence studies and distance education since the emphasis has been on self-directed learning (see section 2.2 for a discussion of this). However, in online education, CMC has made it possible for students and teachers to interact more frequently. Thus, the introduction of physical tools (e.g., computers with internet connection and CMC software) has made it possible to communicate more frequently with peers and teachers, which in turn enables students and teachers to share more experiences and information, and engage in producing joint reifications.

2.1.6 Participating by collaborating

The assumption that underlies this thesis, that student participation enhances learning, is also supported by cooperative and collaborative learning theories. It needs to be clarified that participation should not be regarded as equivalent to cooperation or collaboration. Participation may involve all kinds of relations, conflictual as well as harmonious, intimate as well as political, competitive as well as cooperative (Wenger 1998, p. 56). The basis of collaborative learning is that learning is social rather than individual (Bonk & Cunningham 1998). Littleton and Häkkinen (1999) argue that “collaboration involves the construction of meaning with others and can be characterized by a joint commitment to a shared goal” (p. 21) and Dillenbourg (1999) that it is “a situation in which two or more people learn or attempt to learn something together” (p. 1).

Cooperative and *collaborative learning* are concepts that are used loosely and interchangeably in the literature (Dillenbourg 1999; Underwood & Underwood 1999). The first concept describes “members of [a] group [that] may choose to take responsibility for sub-tasks” while the second describes groups that “work together on all parts of [a] problem” (Littleton & Häkkinen 1999; Underwood & Underwood 1999, p. 12). Students that work collaboratively share the decision-making and therefore they need to communicate frequently. Whether groups choose to work more cooperatively or collaboratively may depend on the task and characteristics of the students in the group (Underwood & Underwood 1999).

Both cooperative and collaborative learning are related with positive effects such as academic learning and student motivation (Underwood & Underwood 1999). In a meta-analysis of 164 studies on cooperative learning, which included 194 independent effect sizes on academic achievement, it was concluded that cooperation among students has a significant positive impact on student achievement (Johnson, Johnson & Stanne 2000). Achievement was defined as an outcome measure for some type of performance (e.g., tests, grades, quality of performances and quality of products). Other identified advantages were that learners think more critically and creatively. Research fields, which conduct research on cooperation and collaboration in computer-mediated settings, are discussed in section 2.3.4. In Table 2.2, key implications of the discussion in section 2.1 for the thesis are listed.

Table 2.2. Implications drawn from the discussion of social perspectives on learning

When departing from a social perspective, learning is viewed as participation in the social world.

Participation is a complex process of taking part and maintaining relations with others.

Participation is not synonymous with talking or writing.

Participation is supported by physical and psychological tools.

Participation may involve collaboration with peers but essentially it may involve all kinds of relations.

2.2 From distance education to online education

In the previous section, social perspectives on learning and participation have been discussed. Online education is an emerging type of distance education, which is inspired by such perspectives. Moore and Kearsley (1996) present the following definition of distance education: “*Distance education* is planned learning that normally occurs in a different place from teaching and as a result requires special techniques of course design, special instructional techniques, special methods of communication by electronic and other technology, as well

as special organizational and administrative arrangements” (p. 2). Some prefer to label this form of education *distance learning* since instructions are provided in places and times that are convenient for learners (Moore & Kearsley 1996). Often, however, the two terms are used synonymously. Initially, I used the term distance learning but nowadays prefer the term distance education since people might participate in distance learning activities (e.g., discuss literature with a friend by using the telephone) without necessarily being enrolled in an educational program or course.

Online education is a new research paradigm that builds on the long history of the fields of correspondence studies and distance education (Harasim 2000; Mason 2000). In line with the reasoning of the previous paragraph, some prefer the term online education while others use the term *online learning*. Inspired by Keegan (1980), Paulsen (2003, p. 25) argues that online education is characterized by:

- the separation of teachers and learners which distinguishes it from face-to-face education
- the influence of an educational organization which distinguishes it from self-study and private tutoring
- the use of a computer network to present or distribute some educational content
- the provision of two-way communication via a computer network so that students may benefit from communication with each other, teachers, and staff.

The latter two characteristics differ between distance and online education. They emphasize the use of computer networks and that students may benefit from communicating with each other, while definitions of distance education have described learners as individuals rather than grouped (Keegan 1980).

2.2.1 Three generations of distance education

The technological evolution of distance education towards online education can be described by using a common classification that

usually includes three generations. It should be reminded that it is the use of technology rather than technology itself that is of importance. How people learn can never be reduced to a specific technology or method: “not even the most powerful information technology will solve the problem of learning, it only changes its conditions” (Säljö, 2000, p. 12, my translation). Classifications of generations have been around for about twenty years (Garrison 1985; Nipper 1989). These generations are not bound to specific time periods, technologies related with each of the generations are still commonly used (Garrison & Anderson 2003).

The *first generation* or correspondence model of distance education was very much a mass production model (Garrison & Anderson 2003; Nipper 1989). The aim was to deliver education, usually in the form of printed textbooks and course guides, to many students. Learning was explicitly defined and “based on positivistic notions that there is a common reality and from it objective learning objectives can be extracted” (Garrison & Anderson, 2003, pp. 35-36). Complex concepts were often divided into easily understandable subcomponents. Students could decide when to start studying and then complete courses at their own pace. At first, in the days of correspondence studies, interaction between the teacher and student was via mail. Therefore the feedback process was slow and mostly restricted to when students had submitted assignments (Nipper 1989). More recently, technologies such as e-mail and telephone have been used. This generation alone has major drawbacks since it, for example, does not make collaborative learning possible. First-generation study guides are still commonly used (Garrison & Anderson, 2003).

The *second generation* was also based on a mass production model, but after having accepted cognitive learning theory, technologies such as radio and television were used which “allowed students to virtually visit the laboratory, the workplace, or to stay within the classroom with the audio and/or video images of their teachers” (Garrison & Anderson, 2003, pp. 36-37). This generation has been developed since the late 1960s (Nipper 1989). Because of high production costs these courses were delivered to large student populations. The teacher was often not the creator of the course but rather a tutor who supported and evaluated students (Garrison & Anderson, 2003). The interaction that

occurred between the teacher and student was restricted to the technologies of the first generation. As a consequence, communication with the students was marginal and communication among learners more or less non-existent (Nipper 1989). However, in the 1970s the interest in group oriented work increased and some distance education courses organized students into groups based on where they lived (Dahlén & Hudner 2002). More recently, within this generation, tools for computer-assisted interaction emerged and included simulations, multimedia and self-paced tutorials (Garrison & Anderson, 2003).

The *third generation* included technologies that support asynchronous and synchronous communication, including CMC and, audio and video conferencing. This generation has been developed since the late 1980s (e.g., Robson & Kaye 1989). The support of many-to-many learning approaches was the motive for talking about a third generation of distance education and motivates the use of the term online education (Harasim 1989). Earlier, cooperative and collaborative learning was not possible (Davies 1989). Drawing on social theories on learning, this generation made collaborative learning possible by introducing appropriate physical tools (Säljö, 2000). Recently, a movement towards Web 2.0, which emphasises the increasing use of social software, can be recognized (O'Reilley 2005). Initial research efforts include discussions of possible benefits of emerging media for online education, such as blogs, wikis and video sharing (e.g., Duffy 2007), and instant messaging, which is investigated in Paper III and IV. The focus of this thesis is on the third generation of distance education.

It has been suggested that a fourth and even a fifth generation has emerged because of the possibilities to retrieve large amounts of information and make use of intelligent technologies. However, online education is usually based on a combination of one or more of the first three generations (Garrison & Anderson, 2003). Koschmann (1996) has presented another classification of generations intended for instructional technology in general without focusing on distance education. Similarly to the three generations of distance education, it illustrates how the focus has shifted from computer-assisted instruction and self-directed learning towards opportunities communication and collaboration.

2.2.2 Four types of interaction

Moore (1989) has distinguished three types of interaction: learner-instructor, learner-content and learner-learner interaction. Later, Anderson and Garrison (1998) added three more types: teacher-content, teacher-teacher and content-content interaction. According to Anderson and Garrison, these “six interactive dyads” illustrate the ways educational interactions may be supported online. In Paper II, the focus was on CMC between individuals involved in education. The review included a comparison of learner-learner, teacher-learner and teacher-teacher interaction. The empirical studies were mainly focused on learner-learner interaction. Factoring the above, the discussion below is focused on four of the six interactive dyads.

Teacher-learner interaction has received attention for many years in both classroom and distance education settings. The teacher is responsible for designing and creating a context which reinforces educational goals in order to achieve higher-order learning outcomes (Garrison & Anderson 2003). Thus, the teacher plays a key role in motivating, supporting and enhancing student interest and learning (Moore 1989). This recognition has led to an interest in research to study how the actions of teachers affect student learning and participation. This thesis has mainly been conducted from a student perspective and has not focused on effects of the actions of teachers. However, it is important to conduct research from the perspective of teachers as well. For example, it has been shown that frequent postings by teachers in discussion forums did lead to fewer student postings even though these teachers were regarded as more enthusiastic and knowledgeable by students (Mazzolini & Maddison 2003). However, a lack of teacher-learner interaction, as was the case in the earlier generations of distance education, has been argued as problematic since it leaves the responsibility of maintaining motivation to the students (Moore 1989).

Learner-content interaction is a defining characteristic of education and has traditionally been the strength of distance education (Moore 1989). According to Wenger (1998), one process related with participation is thinking which is stimulated when, for example, students encounter information and ideas in a text (Moore 1989). Holmberg (1989) has defined the concept of “guided didactic conversations” which include

both real and simulated conversations such as when individual students interact with texts.

Learner-learner interaction is a relatively new dimension because earlier generations of distance education (e.g., correspondence studies) did not make such interactions possible (Garrison & Anderson 2003; Moore & Kearsley 1996). This dimension has made collaborative learning and social support among distance students possible (Garrison & Anderson 2003; Haythornthwaite 2002). According to Gunawardena and McIssac (2004) it is learner-learner interaction that will challenge our thinking in the 21st century. In a major review on distance education literature, they predict that the field will move towards designing learner-centred networked learning communities as a response to research arguing that learner-learner interaction is an important student success factor (e.g., Tuovinen 2000). In such environments, a majority of the interactions occur between students rather than with the teacher (Jaldemark 2005). The focus of research in this area is on “how to get students to participate in online discussions with each other” and “how to evaluate their contribution when they do contribute” (Mabrito 2006, p. 93).

In the empirical studies, it was explained that learner-learner interaction has both cognitive (e.g., communicate content) and social interaction (e.g., emotional support) aspects. When using shared areas for both teacher-learner and learner-learner discussions, “students often feel inhibited from discussing real concerns and obtaining the affective support they need” (Tuovinen 2000, p. 20). Thus, the students not only benefit from conversations with their teachers but also from conversations with other students, both formally and informally (Lake 1999). One way of acknowledging the social needs of students is by making it possible for students to communicate with each other without the presence of teachers, an approach which was studied in Paper III and IV.

Teacher-teacher interaction was not added to Moore’s interaction model until 1997. However, conferences on the internet for teachers and researchers have been held since 1992 (Garrison & Anderson, 2003). An example is INFORMS’s IS teaching community. Teacher-teacher interaction is the basis of a learning educational organization and is “essential in providing the multiple perspectives needed to develop instruction in complex domains and especially multicultural domains

common to e-learning” (Garrison & Anderson, 2003, pp. 45-46). Teacher-teacher interaction has been given little attention in this thesis. However, in Paper II the frequency of occurrences of this type of interaction in research was examined.

A limitation of the four dyads that have been discussed above is that they only account for interactions within the educational context. It can be assumed that students maintain important interactions with, for example, friends, family and colleagues. We still know little about these relations although research on this issue is emerging (e.g., Haythornthwaite & Kazmer 2004).

2.2.3 Three types of exchanges

The four types of interaction listed above have identified the dyads of actors that are commonly associated with online education. Another issue is to understand the kinds of communication that are important for these actors. Haythornthwaite (2002) argues that in particular three types of exchanges are important for building and sustaining learning communities: information exchange, task support and social support (see Table 2.3).

Table 2.3. Three types of exchanges (adapted from Haythornthwaite, 2002)

Type of exchange	Examples
Information exchange	Ask or answer a course-related question Share information Express an idea or thought
Task support	Plan work, allocate tasks, coordinate joint efforts, or review drafts Negotiate and resolve conflicts
Social support	Express companionship, emotional aid, or advice Emoticons (e.g., ☺, ☹) Support during an upset (e.g., support when having technical difficulties) Talk about things other than class work

Online educators should aim to support at least these three types of exchanges. Note, that the category of emotional support, i.e. “help in a minor or major upset” (Haythornthwaite 2000, p. 202), was used to

distinguish a “deeper” form of social support in Paper IV. However, since participants found it difficult to understand the difference between social and emotional support, it was omitted in the other empirical studies. There is a thorough discussion of these types of exchanges and their importance in Paper V. In Table 2.4, key implications of the discussion in section 2.2 for the thesis are listed.

Table 2.4. Implications drawn from the discussion of the change from distance education towards online education

The third generation of distance education, commonly referred to as online education, includes CMC and has enhanced opportunities for participation in many-to-many activities.

Online student participation may be enhanced by providing technical support for different types of interaction (e.g., learner-learner interaction) and exchanges (e.g., task support).

2.3 Computer-mediated communication

In the previous section, the term online education was discussed. It was argued that online education enables many-to-many learning approaches involving at least four types of interactions and three key types of exchanges. These interactions and exchanges are primarily supported by CMC media. Since the internet became widespread the popularity of CMC has increased dramatically. Many use e-mail every day, programmers help others they have never met using discussion boards (e.g., Microsoft Newsgroups), people socialize in chat rooms and via instant messaging (IM) systems (e.g., Boneva et al. 2006), and online students communicate with each other and their teachers by using various media (Haythornthwaite 2000, 2001). Jones (1995) has presented a commonly cited broad definition of CMC:

CMC, of course, is not just a tool; it is at once technology, medium, and engine of social relations. It not only structures social relations, it is the space within which the relations occur and the tool that individuals use to enter that space. (p. 16)

Before the widespread use of CMC, Keegan (1980) argued that one of the key elements of distance education is that learners are taught as

individuals rather than grouped. However, as acknowledged above, technology-mediated two-way interactive communication has become a central aspect of definitions of distance education (Garrison & Shale 1987). Garrison (2000) has argued that there is especially a need for “theory that informs and explains computer mediated communication” (p. 12).

In line with social theories on learning, the main advantage of CMC for online education is that it has enabled students to communicate with and learn from each other (Harasim 1989). In fact, students, rather than teachers, write a majority of the messages in CMC systems. For example, in a synchronous setting it was reported that students sent 85% of the messages (Slatin 1992) and in an asynchronous setting this figure was 80% (Zhu 1998). Such results support claims that CMC has transformed learning environments from being teacher-centred to learner-centred (Fåhræus 2003; Kang 1998). Thus, it is not only possible to download educational material but also to learn with others within a social context (Lindberg & Olofsson 2005). Interestingly, some students feel that they learn more from explanations given by other students rather than from teachers (Fåhræus 2003).

Drawing on sociocultural theory on learning (Säljö 2000; Vygotsky 1978), CMC supports students in learning together by using physical (computer with CMC software) and psychological (language) tools: “More capable peers or adult guides on a computer network might lead students into cognitive processes of writing and communication that they might not independently consider” (Sugar & Bonk 1998, p. 132). Similarly, according to social learning theory (Wenger 1998), students participate in communities and continuously attempt to reify ideas in the form of text. Thus, there is theoretical support for that CMC may support learning, especially when departing from social theories on learning. In the next section, literature on different types of CMC is reviewed to provide a background to the empirical studies. It will be argued that CMC media are designed for certain ways of communicating even though they are not necessarily used in such ways.

2.3.1 Asynchronous and synchronous communication

CMC is commonly classified as *asynchronous* or *synchronous*. However, it should be noted that it is the users, and not the medium itself, that decide how to use a medium. It would be naïve to argue that some CMC media are always the “best” or “richest” since “a medium’s capability may vary by how it is used, the context in which it is used and the convenience of its use” (DeLuca & Valacich 2006, p. 340). For example, in some instances, e-mail has been reported to be used near-synchronously since users may remain logged in and monitor their e-mail continuously (Haythornthwaite 2000, 2001; Markus 1994). Björck (2004) found that there was a strong urge among students to communicate synchronously during the initial phase of a problem-based learning case. In order to communicate synchronously, they scheduled meetings in a discussion forum that was designed for asynchronous communication. Furthermore, two users may be logged into a chat but communicate asynchronously, while doing something else, by sending a message to each other once in a while. In fact, Fåhræus and Döös (2006) argue that chat is not as synchronous as face-to-face conversations since people engaged in face-to-face conversations can change their mind in the middle of an utterance after taking account of the listener’s facial expressions. It can be concluded that practitioners of online education (e.g., teachers, administrators and designers) not only need to choose media suitable for various learning activities – they also need to stimulate beneficial uses of the chosen media.

The difference between asynchronous and synchronous communication is often a matter of degree. As noted above, e-mail is commonly labelled an asynchronous medium even though one user may read and answer e-mails as they arrive, while another user may read and answer e-mails once a week. In such cases, researchers might want to study the degree of synchronicity of media use (DeLuca & Valacich 2006). On the other hand, using simpler categories such as asynchronous and synchronous communication, at least gives us a simplified view of benefits and limitations of different types of communication, since each medium “emphasizes, amplifies, and enhances particular kinds of experience” but “also inhibits, restricts, and diminishes other kinds of experience” (Swan & Shea 2005, p. 253). Thus, even though users may use e-mail to communicate with a varying

degree of synchronicity, it was designed for asynchronous communication and most users use it in that way. In short, some media better support asynchronous or synchronous communication but the users decide whether to use them in that way or not (Hrastinski 2007a).

Asynchronous and synchronous communication is characterized by different discourse features and may thus be used for different pedagogical purposes (Romiszowski & Mason, 2004). It has been argued that *asynchronous communication* may provide more student control and flexibility (Kearsley 1995). It is the most common type of communication in distance and online education (e.g., e-mail, discussion board) ever since the days of correspondence studies (e.g., letters). Asynchronous communication allows online students to log on to the class at any time, think about what has been written and formulate considered replies when they wish (Palloff & Pratt 1999; Tuovinen 2000). Thus, students have more time for reflection (Hansen et al. 1999) since discussions usually are scheduled for the entire course or a longer time period (e.g., a week). The advantageous “anytime, anywhere” feature of asynchronous communication makes it unavoidable in online education. Students with other obligations such as family and work may still participate on weekends, at night or in small chunks throughout the day since all communication is stored (Haythornthwaite & Kazmer 2002). However, this feature may in some cases be disadvantageous since the postings can be accessed by all participants including the teacher and create a fear of public ridicule (e.g., Contreras-Castillo et al. 2004; Grint 1989):

Students feel constrained at the permanence of the postings and try to create a finished product rather than a work in progress. Students also express admiration of the other people’s postings and often feel intimidated in participating via this medium, although required to in most classes. (Haythornthwaite 2000, p. 205)

Many educators have experimented with using CMC to address the commonly mentioned problem of isolation among distance and online students. However, asynchronous methods have been reported not to be sufficient in many cases, which has led to that some advocate using synchronous communication as an enhancement to online courses (Schullo et al. 2005). When relying solely on asynchronous communication, it has been reported that some students stop

“attending class” when being busy with other things (Hiltz & Wellman 1997). The reason seems to be that it is easy to postpone attendance when communicating asynchronously. In fact, making time for communication has been found to be a strong predictor of student success, measured as final grade, in courses that are mainly based on asynchronous communication (Loomis 2000). In fact, Grint (1989) has reported that most students regard the lack of spontaneous and real time exchanges as disadvantageous.

The characteristics of *synchronous communication* are quite different since conversations are conducted in real-time. The main pedagogical assumption that motivates communicating synchronously is that participation is critical to the learning process (Leidner & Jarvenpaa 1995). Such communication may be disadvantageous since participants have to decide a date and time if they do not meet online by coincidence. Often online students have other responsibilities (e.g., family and work) or may be located in different parts of the world, which makes it difficult to decide times for meetings. However, there are also many reported advantages.

Synchronous communication has been argued to enhance community (Dawson 2006) and accelerate information flows within a team (Carr et al. 2004). Moreover, since it has been acknowledged that feedback is less effective if it is delayed (Tuovinen, 2000) synchronous communication may be advantageous in some circumstances. Synchronous communication is often experienced as richer than asynchronous communication because of “immediate feedback so that interpretation can be checked” (Daft & Lengel 1986, p. 560) and may therefore be useful in online education.

Leidner and Jarvenpaa (1995) showed that all members of a class contributed in computer-mediated synchronous discussions and that students communicated with each other or the entire class rather than on a one-to-one basis with the teacher, when comparing with the traditional classroom. It has also been concluded that synchronous live sessions help students to feel like participants rather than isolates: “Isolation can be overcome by more continued contact, particularly synchronously, and by becoming aware of themselves as members of a community rather than as isolated individuals communicating with the computer” (Haythornthwaite & Kazmer, 2002, p. 459). In fact,

according to Kearsley (1995), distance education classes that communicate synchronously “often have a sense of excitement and spontaneity that is not present with delayed interaction”.

Factoring the above, asynchronous and synchronous communication seem to complement each other. The combination of means of communication support several ways for students to get to know each other and collaborate on work (Haythornthwaite & Kazmer, 2002) since the nature of the medium affects communication (Hammond 2000; Ligorio 2001). If agreeing that different media may be used complementarily, researchers ought to conduct studies that investigate asynchronous, synchronous and mixed approaches. However, during the last years it has been quite uncommon to conduct research on synchronous communication. In Paper II, it was found that about a third (30%) of the articles that discussed CMC in education mentioned synchronous communication. Despite the fact that we know that online students find both asynchronous and synchronous communication useful (e.g., Haythornthwaite & Kazmer 2002; Spencer 2002), it was also found that few articles discussed both types of communication (18%).

Comparative studies of asynchronous and synchronous communication

Paper V provided a thorough review of comparative studies on asynchronous and synchronous communication in blended⁶ and online education. It was found that most studies have compared text-based discussion board and chat in higher education settings. They have mainly relied on social, collaborative and constructivist learning theories. The main analysis methods have been content analysis of electronic logs, surveys and interviews. In line with the discussion above, many reviewed studies suggest that, when the purpose of a discussion is to discuss complex ideas, the discussion board is preferable. Some studies suggest that chat may be used to increase communication and social exchanges among students.

⁶ Blended education or learning is commonly defined as the combination of traditional and online approaches (Graham 2006).

2.3.2 Studies on instant messaging

Paper II revealed that research has so far emphasized the study of text-based asynchronous communication by discussion board although many other types of CMC media are used today. IM is commonly used but is one of the media that has not received the research attention it warrants (Flanagin 2005). In Sweden, 74% of adolescents use Microsoft's IM system MSN Messenger, which indicate that they may continue using the medium in their university studies and working life (Lindström 2006). IM can be used to communicate with people on a list of "friends". It differs from chat since users can be contacted spontaneously when they are online, e.g., meetings do not need to be scheduled. In Table 2.5, research on IM is summarized.

The papers reviewed present beneficial results although only three of the studies (Contreras-Castillo et al. 2004; Contreras-Castillo, Perez-Fragoso & Favela 2006; Nicholson 2002) focused on IM use in online education. It should be noted that the Open University in the UK conduct research on IM in education. However, they have focused on describing the development of an IM system and why it was introduced, rather than conducting a rigorous evaluation (Eisenstadt, Komzak & Dzbor 2003).

Cameron and Webster (2005) presented a review of IM research that was based on twelve articles, most of them being presentations at human-computer interaction conferences. Many of the studies reviewed were not supported by underlying theories. The reviewed research has demonstrated that IM is used to support informal conversations in virtual teams and is often used in combination with other media or computer-based tasks.

Table 2.5. Studies on IM (table structure adapted from Cameron & Webster 2005)

Source	Theory base	IM system	Participants	Data collection	Findings
Boneva et al. (2006)	Media richness, social presence	Not specified	41 adolescents	Survey, interviews	“IM boosts adolescent’s group identity and is so popular because it simulates spending time with an offline group of friends, without the rigidity of the acceptance rules of adolescent offline peer groups.” (p. 613)
Cameron and Webster (2005)	Comm. and electronic monitoring theories	In-house, Lotus SameTime, AOL Instant Messenger, ICQ	19 employees from four organizations	Interviews	“Results suggest that critical mass represents an important factor for IM success in the workplace, that IM symbolizes informality, and that IM is perceived to be much less rich than face-to-face communication.” (p. 85)
Chen, Yen and Huan (2004)	Media richness, social presence	Not specified	476 undergraduate students	Survey	“IM users tend to use IM for both social reasons and course/coursework.” (p. 387)
Contreras-Castillo et al. (2004)	Not specified	In-house developed (Centers)	43 students in four online courses	Survey, content analysis	“[IM] helps students reduce their feeling of isolation and increases collaboration among course participants. Additionally students who interacted more reported greater satisfied with the course in general, although this was not necessarily due to the use of the system.” (p. 149)

Source	Theory base	IM system	Participants	Data collection	Findings
Contreras-Castillo et al. (2006)	Not specified	In-house developed (Centers)	43 students in four online courses	Survey, content analysis	“The results suggest that the use of instant messaging during online courses increases students’ satisfaction by providing continuous opportunities for interaction with the teacher and classmates” (p. 216).
Flanagin (2005)	Uses and gratifications theory	Not specified	271 undergraduate students	Survey	“[R]espondents exhibited a high capacity for multi-tasking in IM conversations, and results suggest displacement effects, particularly of email by IM.” (p. 175)
Kinzie, Whitaker and Hofer (2005)	Not specified	Hand-held computers with IM software	36 undergraduate students of blended education	Content analysis, group interviews, observat.	“[S]tudents’ discussions indicate that they were capable of ... expressing opinions and exploring instructionally relevant topics. However ... both students and the instructors expressed some discomfort with discussion occurring synchronously with classroom lectures.” (p. 150)
Nicholson (2002)	Not specified	AOL Instant Messenger	30 online master students	Survey	“[S]tudents who used IM services found it easier to communicate, felt a stronger sense of community, and had more venues for informal and social communication about not only class material, but also information about the school and their common degree program.” (p. 363)

2.3.3 Theories on communication media

The discussion above reveals that communication ranges from being asynchronous to synchronous and that CMC media are designed for certain ways of communicating even though they are not necessarily used in such ways. In order to bring clarity, researchers have built theories that explain media choice and use. Media richness theory argue that “communication media vary in the capacity to process rich information” (Daft & Lengel 1986, p. 560). Face-to-face communication is an example of a rich medium while numeric documents is an example of a lean medium. The theory proposes that rich media are appropriate for reducing uncertainty, defined as “absence of information”, and equivocality, defined as “existence of multiple and conflicting interpretations” (p. 556). However, many studies that have tested the media richness theory have found mixed or conflicting results (for reviews see Kock 2005; Robert & Dennis 2005). For example, Markus (1994) showed that lean media, such as e-mail, can be used for complex communication and can be used in rich ways, if encouraged by the social context. Thus, teachers of online education not only need to choose appropriate media, but they also need to show how beneficial such media can be. Moreover, comparative research, on asynchronous and synchronous communication in online education, has found that asynchronous or lean communication is preferable when discussing complex issues (see the literature review of Paper V).

The limitations of the media richness theory have led to researchers proposing less technologically deterministic theories by taking account of social behaviour and cognitive-based views of media use (Kock 2005; Robert & Dennis 2005). In this thesis, two complementary theories will help explain *why* the empirical results were obtained (see section 6.2). These are Kock’s (2005) media naturalness hypothesis and Robert and Dennis’ (2005) cognitive model of media choice.

The media naturalness hypothesis is based on the idea that “human beings evolved a biological communication apparatus through millions of years of Darwinian adaptation and that such apparatus is largely designed for face-to-face communication” (Kock, Verville & Garza 2007, p. 335). It is concerned with the degree of naturalness of a communication medium (or its degree of similarity to the face-to-face

medium). It assumes that natural communication involves the following key elements: (1) a high degree of co-location, (2) a high degree of synchronicity, (3) the ability to convey and observe facial expressions, (4) the ability to convey and observe body language, and (5) the ability to convey and listen to speech (Kock 2005). Synchronous communication is assumed to be more “natural” than asynchronous communication since it closer resembles face-to-face communication. The media naturalness hypothesis argues that, other things being equal, a decrease in the degree of naturalness of a communication medium leads to the following effects: (1) increased cognitive effort, (2) increased communication ambiguity, and (3) decreased psychological arousal (p. 117).

The cognitive model of media choice argues that individuals need to be motivated and have the ability to process messages (Robert & Dennis 2005). The model argues that “the use of rich media high in social presence induces increased motivation but decreases the ability to process information, while the use of lean media low in social presence induces decreased motivation but increases the ability to process information” (p. 10). Social presence has been defined as the “degree of salience of the other person in a mediated communication and the consequent salience of their interpersonal interactions” (Short, Williams & Christie 1976, p. 65). Some media are characterized by greater social presence (e.g., videoconferencing) than other (e.g., e-mail) and enable higher levels of intimacy and immediacy. Robert and Dennis propose that synchronous communication makes it possible to monitor the receiver’s reaction to a message, which leads to the receiver being more committed and motivated to read it. However, when communicating asynchronously, the receiver has more time to comprehend the message since the sender does not expect an immediate answer.

Interestingly, the media naturalness hypothesis, and the cognitive model of media choice, support and complement each other. Kock argues that low synchronicity will lead to increased cognitive effort. Similarly, Robert and Dennis argue that low synchronicity increases the ability to process information. Kock argues that high synchronicity will lead to increased psychological arousal. Similarly, Robert and Dennis argue that high synchronicity induces increased motivation and decreased ambiguity. Despite criticizing the media richness theory, the

cognitive model of media choice is somewhat technologically deterministic. Robert and Dennis do not acknowledge that it is the users, and not the medium itself, that decide whether to use a medium asynchronously or synchronously. As discussed earlier, in some organizations, near-synchronous use of e-mail have been encouraged. Kock acknowledges this when arguing that media naturalness “may or may not lead to certain types of behavior or task outcomes” since users do not always rationally choose the most appropriate medium because of, for example, influences from the social context (Markus 1994). However, a certain medium might better support synchronicity, naturalness or social presence because of its characteristics.

2.3.4 Computer-supported collaborative learning and work

Several research fields conduct research on cooperation and collaboration in computer-mediated settings, commonly supported by CMC media. In this section, I will focus on the fields of *computer-supported cooperative work* (CSCW), *computer-supported collaborative learning* (CSCL) and *asynchronous learning networks* (ALN), which have inspired this thesis.

The research field of CSCW was coined at a workshop in 1984 and has been defined as “the specific discipline that motivates and validates groupware design. It is the study and theory of how people work together, and how the computer and related technologies affect group behaviour.” (Greenberg 1991, p. 1). The CSCW area is related with research on, for example, groupware and group decision support systems. In more recent days, research on knowledge management systems, where the focus is on creating, storing, sharing and applying knowledge, has received increased attention (Alavi & Leidner 2001a).

The inspiration for CSCL partly arose from research on CSCW (Lipponen 2002). The CSCL field has emerged since the first workshop took place in 1991 (Koschmann 1994) and the first international conference in 1995 (Lipponen 2002). Lipponen provides the following definition of CSCL: “CSCL is focused on how collaborative learning supported by technology can enhance peer interaction and work in groups, and how collaboration and technology facilitate sharing and

distributing of knowledge and expertise among community members” (p. 72).

There have been different suggestions for the “C” word, for example, collective, coordinated, cooperative and collaborative, where the latter suggestion is the most commonly adopted (Lipponen 2002). Nevertheless, Koschmann (1996) argues that CSCL should be viewed as a new paradigm in IT research since it is based on different assumptions about the nature of learning, i.e. “social constructivism, Soviet sociocultural theories, and situated cognition” (p. 13). Thus, this thesis shares the theoretical underpinning of CSCL research, which generally stresses the importance of social theories on learning. Another similarity between this thesis and the CSCL field is the interest in content analyses in “real world contexts” (Lipponen 2002).

Heeren (1996) compared the CSCW and CSCL fields and identified three key differences: (a) the context, in CSCL the participant is viewed as a learner rather than a member; (b) the process, in CSCL the focus is on participation since this process is considered central to learning; and (c) the outcome, in CSCL, learning is the major outcome while CSCW aims to produce abstract or concrete products.

Finally, the research community focused on ALN should also be mentioned. Almost 30 years ago, Hiltz and Turoff’s (1978) seminal book on how CMC can support work and learning groups was published. Building on this early research, the ALN field is focused on online education that uses asynchronous CMC to connect learners and instructor(s) (Hiltz & Goldman 2005; Hiltz & Turoff 2002). Research on ALN has been an important source of inspiration for this thesis. For example, the assumption that participation drives learning is supported by several studies conducted by ALN researchers (Fredericksen et al. 2000; Hiltz et al. 2000). In Table 2.6, key implications of the discussion in section 2.3 for the thesis are listed.

Table 2.6. Implications drawn from the discussion of CMC in education

Online student participation may be enhanced by providing technical support, such as CMC media.

CMC media are commonly classified as asynchronous or synchronous but it is the users, and not the medium itself, that decide how to use a medium.

Online student participation may be supported in different ways by using different media because each medium has different characteristics.

Asynchronous communication may induce increased cognitive effort since students have more time for reflection.

Synchronous communication may induce increased motivation and decreased ambiguity because of possibilities for immediate feedback.

2.4 Online student participation

The importance of student participation has been emphasized for quite a long time in traditional education (e.g., Pratton & Hales 1986), especially when such education is inspired by constructivist, collaborative and social learning theories. As noted above, in the review of the generations of distance education, distance students have traditionally studied more independently because of technical limitations. However, ever since Moore (1989) recognized learner-learner interaction as an important dimension of distance education, participation has received more attention. Moore and Kearsley (1996) have argued that achieving student participation is the most important challenge of distance education. Thus, the emphasis has moved from presentation towards participation over the years:

The single most important skill that all distance educators must develop is to make their students active participants in their educational program. It is not too difficult to present information over a distance, but getting people to participate and making learning active at a distance is much harder. (Moore & Kearsley 1996, p. 133)

It seems widely agreed upon that it is critical to enhance participation in distance and online education. Paradoxically, current conceptualisations

of participation differ considerably – researchers seem to agree on the importance of online participation even though they do not agree upon the meaning of the concept.

2.4.1 What is online student participation?

When reviewing the literature, it is evident that online student participation has been conceptualised in different ways. What I call *low level conceptions* of online participation include research that refers to participation as something “simple” that can easily be measured by quantitative means, such as the number of times a learner accesses a learning environment (e.g., Davies & Graff 2005) or the number of messages students read or write (e.g., Lipponen et al. 2003). The following definition is typical for such approaches: “One can define at least two forms of participation in CSCL [computer-supported collaborative learning] environments: writing notes and reading notes (‘lurking’)” (Lipponen et al. 2003, p. 492).

High level conceptions of online student participation encompass low level conceptions but emphasize that participation is a complex phenomenon. Inspired by social perspectives on learning, such conceptions acknowledge that participation is not something students can turn on and off. Thus, students are participating not only during times when they are, for example, writing or reading messages. From this perspective, it is commonly argued that student perceptions are of key importance in understanding online participation. The following definition, which is similar to Wenger’s (1998) definition of participation that underlie this thesis, acknowledges the complexity of online student participation:

In this article, the authors define participation as taking part and joining in a dialogue for engaged and active learning. Participation is more than the total number of student postings in a discussion forum. (Vonderwell & Zachariah 2005, p. 214)

Wenger (1998) views participation as a complex phenomenon that involves taking part, doing (e.g., reading), thinking (e.g., reflecting), feeling (e.g., support during an upset) and belonging (e.g., feeling attached to a group). One step towards a better understanding of online

student participation may be to add other dimensions such as interaction with content (Bento & Schuster 2003). In doing this, Anderson and Garrison's (1997) "six interactive dyads" which include content, are at least to some extent, taken into account. However, researchers are far from a deep theoretical understanding of participation since, for example, dimensions of thinking, feeling and belonging are commonly not addressed. In this thesis, it is argued that a broader understanding of participation is needed, an argument that is further discussed in the next chapter.

2.4.2 Participation and related variables

The benefits of student participation, including positive effects on learning, satisfaction and retention, are almost taken for granted. For example, some researchers write that participation is necessary or that it enhances student learning without referring to any studies that support such statements (e.g., Brown & Duguid 1996; Williams, Paprock & Covington 1999). It should be mentioned that most studies have used simplistic frequency measures of participation such as message counts, while this thesis aims to better acknowledge the complexity of participation. The review below presents convincing evidence in support of that participation may affect learning outcomes and satisfaction, and at least some evidence in support of that participation may affect retention rates positively.

Participation may affect learning positively

The superiority of participation by interacting with other students as compared with individualistic approaches has been documented in numerous empirical studies in traditional settings (for reviews see Alavi 1994; Brown & Palincsar 1989). These benefits include spending more time synthesizing and integrating ideas and concepts, and promotion of problem solving, critical and active thinking skills. In a meta-analysis of 164 studies on cooperative learning which included 194 independent effect sizes on academic achievement, it was concluded that cooperation among students has a significant positive impact on student achievement (Johnson et al. 2000). As already stated in section 2.1.6, achievement was defined as an outcome measure for some type

of performance (e.g., tests, grades, quality of performances and quality of products). Moreover, in a study that included 82 different student outcome measures, it was concluded that “the greater the interaction with peers, the more favorable the outcome” (Astin 1996, p. 126).

Research has argued that learning in online education is best accomplished when students feel that they participate and collaborate (e.g., Bento & Schuster 2003; Leidner & Jarvenpaa 1995; Webster & Hackley 1997). There is convincing empirical evidence that supports such statements. In a survey completed by 1,406 online students at the State University of New York, it was concluded that the results that stand out most clearly for learning effectiveness were: (1) interaction with the teachers; (2) levels of participation compared to classroom; and (3) interaction with classmates (Fredericksen et al. 2000). Learning effectiveness was measured as perceived learning by students.

Based on three studies conducted over five years on 26 online courses at the New Jersey Institute of Technology, it was concluded that student participation in collaborative or group learning were related with as high or higher learning outcomes as those in traditional settings. However, when “simply receiving posted material and sending back individual work, the results are poorer than in traditional classrooms” (Hiltz et al. 2000, p. 120). Learning outcomes were measured as perceived learning by students and teachers, grades and quality assessment of assignments.

Morris, Finnegan and Sz-Shyans’ (2005) study may give a more detailed view of the influence of student participation on learning outcomes, measured as final grade. The study was based on 354 online students at the University of Georgia. Four frequency variables (e.g., number of written discussion posts) and four duration variables (e.g., seconds spent viewing content pages) explained 31% of the variability of student grades. Three of these variables were statistically significant and, thus, good predictors of final grade; number of discussion posts viewed, number of content pages viewed and seconds viewing discussions. These results underline that research should not rely solely on the number of contributed postings as a measure of student participation.

Strong evidence underlies the claim that student participation affects learning outcomes positively, although not all researchers are convinced. For example, on the basis of a review of the literature and small empirical study, Picciano (2002) supports some of the studies reviewed above by concluding that there generally is a “strong relationship between students perception of interaction and perceived learning” (p. 33). However, Picciano’s small scale study found that “the low interaction group perceived themselves to have made a higher number of postings than they actually did and the high interaction group perceived themselves to have made fewer postings than they actually did” (p. 32). Similarly, it has been reported that low-ability students tend to overestimate their ability while the opposite has been reported for high-ability students (Kruger & Dunning 1999). In sum, the research reviewed above suggests that, if students are interacting and collaborating with teachers and peers, it is likely that they will be related with better learning outcomes, at least when learning is measured as perceived learning, grades, tests, and quality of performances and assignments.

Participation may affect satisfaction positively

Another variable that has been argued to positively affect retention rates is student satisfaction (Rovai et al. 2004). According to Picciano (2002), “both students and faculty typically report increased satisfaction in online courses depending on the quality and quantity of interaction” (p. 22). Strong evidence was presented based on a survey completed by 52,218 students at the University of Central Florida, in which Picciano’s statement was found statistically significant for all types of education examined, i.e. online, mixed mode and web-enhanced courses (Dziuban & Moskal 2001). Likewise, Gunawardena and Zittle (1997) identified social presence, mainly measured as social interaction, as “a very strong predictor of satisfaction” (p. 8) in a study of 50 students from five American universities. Similarly, from a qualitative perspective, it has been reported that students who collaborated and engaged in social interaction felt they had gained most from a course (Wegerif 1998).

In a literature review, Lamport (1993) argued that informal interaction in peer groups but also with faculty is the primary source of student satisfaction in traditional education. Supporting this statement, it has

been found that college courses that included collaborative learning resulted in students who “were more satisfied with their learning experience and evaluated their courses more favorably” (Alavi & Dufner 2005, p. 193). The statement is also supported by Rovai and colleagues (2004). They argue that students who participate in learning communities may be related with a higher level of student satisfaction. Similarly, research suggests that participating by maintaining relations with peers increase students’ positive attitudes about classes (Mabrito 2006). However, it can be hypothesized that student satisfaction might decrease if students are expected to participate “too much” by, for example, being expected to contribute with a very high number of postings in order to pass a course.

Participation may affect retention positively

In line with social theories on learning, interpersonal relations with others is one of the most important aspects of student participation. It has been widely acknowledged that learner-learner interaction is important, both by students serving as resources to each other but also by providing psychological (e.g., motivational) support for one another (Underwood & Underwood 1999). Anecdotal advice suggests that many distance students are in need of personal interaction and feedback (Carr 2000). However, students’ need for social communication has often been ignored; one common consequence of this has been argued to be high dropout rates in comparison with traditional education (Carr 2000; Münzer 2003; Parker 1999; Schullo et al. 2005; Schweizer, Paechter & Weidenmann 2003).

Carr (2000) has argued that there is significant variation among institutions. It has been suggested that retention rates of distance education varies between 50 and 80%, which is about 10 to 20% higher when compared with traditional education (Carr 2000). In 2006, the retention rate of Swedish online courses was 59%. However, the retention rates differed considerably when comparing universities, from 26% at Stockholm University to 81% at Karolinska Institutet (Forsberg 2007). It may be argued that the low retention rates are understandable since distance students often have other commitments such as work and family (Haythornthwaite & Kazmer 2002; Westerberg & Mårald

2006). In fact, work commitments have been shown to negatively correlate with persistence in distance education (Kemp 2002).

On the basis of a literature review, Rovai (2002) discusses reasons for the high dropout rates in distance education. Apart from the fact that some adults enrol to obtain knowledge rather than credit, most factors seem to be related with student participation. The physical separation seems to reduce students' sense of community. It makes them feel disconnected and isolated, and it lacks personal attention. In traditional schools, higher retention rates have been reported to be related with students' sense of belonging, membership and engagement. For example, in a worksite program for adults, it was found that "84 percent of completers belonged to class cliques, whereas 70 percent of dropouts were socially isolated" (Rovai 2002, p. 2). It has also been shown empirically that social integration has a significant positive effect on retention in a higher education business program. Moreover, participating by maintaining relations with peers, have been argued to increase student motivation (Mabrito 2006). Similarly, Wegerif (1998) reported that students who did not collaborate and engage in social interaction fell away from the course.

Participation and other variables

Throughout this thesis it has been emphasized that participation is a complex phenomenon, which cannot be easily distinguished from other related variables. The difference between participation and, for example, motivation, engagement, involvement and conflict, is somewhat unclear and depends on how each of the terms are defined.

Motivation "means to be moved to do something. A person who feels no impetus or inspiration to act is thus characterized as unmotivated, whereas someone who is energized or activated towards an end is considered motivated" (Ryan & Deci 2000, p. 54). Thus, it may be argued that individuals need to feel motivated in order to be moved to participate in online education (Hansen et al. 1999). The most basic distinction in motivation research is between "intrinsic motivation, which refers to doing something because it is inherently interesting or enjoyable, and extrinsic motivation, which refers to doing something because it leads to a separable outcome" (Ryan & Deci 2000, p. 55).

Participation is probably dependent on both these types of motivation. Social contextual conditions are key in enabling intrinsic motivation (Ryan & Deci 2000) and may enhance participation. It is also commonly argued that extrinsic motivation, such as assessment, affects participation positively (Palloff & Pratt 1999).

Involvement is a concept related with participation. Astin (1999) defines student involvement as “the amount of physical and psychological energy that the student devotes to the academic experience” (p. 518). This definition seems to partly overlap with the definition of participation used in this thesis. However, Wenger’s (1998) definition of participation is more focused on psychological dimensions, rather than being concerned with the physical location of students.

Cognitive engagement is a concept that is often used in motivation research. For example, Meece, Blumenfield and Hoyle (1988) argue that students’ cognitive engagement depend on motivation. Educational psychologists have argued that a high level of cognitive engagement can be achieved through self-regulated strategies, where students manage their own learning with a high degree of autonomy rather than through help-seeking strategies (Corno & Mandinach 1983; Meece et al. 1988). In contrast, the theoretical underpinnings of this thesis emphasize the importance of interpersonal relations for student participation and learning.

Learning and participation can lead to both positive and negative results (Wenger 1998). For example, someone might learn to be a physician by participating in a community, while participation in another community might lead to “successfully” learning a life of crime on the street. Participation may involve all kinds of relations, including conflictual and competitive ones (Wenger 1998). One of the three types of exchanges discussed in section 2.2.3, task support, includes negotiating and resolving conflicts (Haythornthwaite 2002). However, more research is needed on how conflictual and competitive relations influence participation, before these variables can be further operationalised.

2.5 Summary and conclusions

In this chapter, it has been established that participation is not synonymous to concepts such as communication, collaboration and community although they are related. Participation was defined as “a process of taking part and also to the relations with others that reflect this process” (Wenger 1998, p. 55). In order to maintain “relations with others” we need to communicate. Moreover, collaboration is likely to occur if maintaining close relations. The “process of taking part” is related with what is referred to as sense of community in the literature – some describe participation as belonging to a community (Jaldemark et al. 2006).

The relationships between online student participation and related variables have been depicted in an initial model (see Figure 2.1). Participation, learning and other variables of online education occur in an *educational context*. Even though this thesis mainly has studied online education from a student perspective, it should be clarified that it is the teacher that is responsible for designing a context, which reinforces educational goals in order to achieve higher-order learning outcomes (Garrison & Anderson 2003). The educational context, and the variables that may be studied in this context, is also influenced by many other factors, including student attitudes and the type of course (see section 6.5 for a retrospective evaluation of influencing factors).

In this chapter, it has been argued that possibilities for participation were improved considerably with the advent of the third generation of distance education, which led to the introduction of the term online education. Technical support for different types of interaction (e.g., learner-learner interaction), exchanges (e.g., task support) and means of communication (e.g., synchronous) can jointly enable participation. In order to bring clarity, researchers have built theories that explain media choice and use. These include the media richness theory, the media naturalness hypothesis and the cognitive model of media choice. The latter two are used when explaining the empirical results of this thesis.

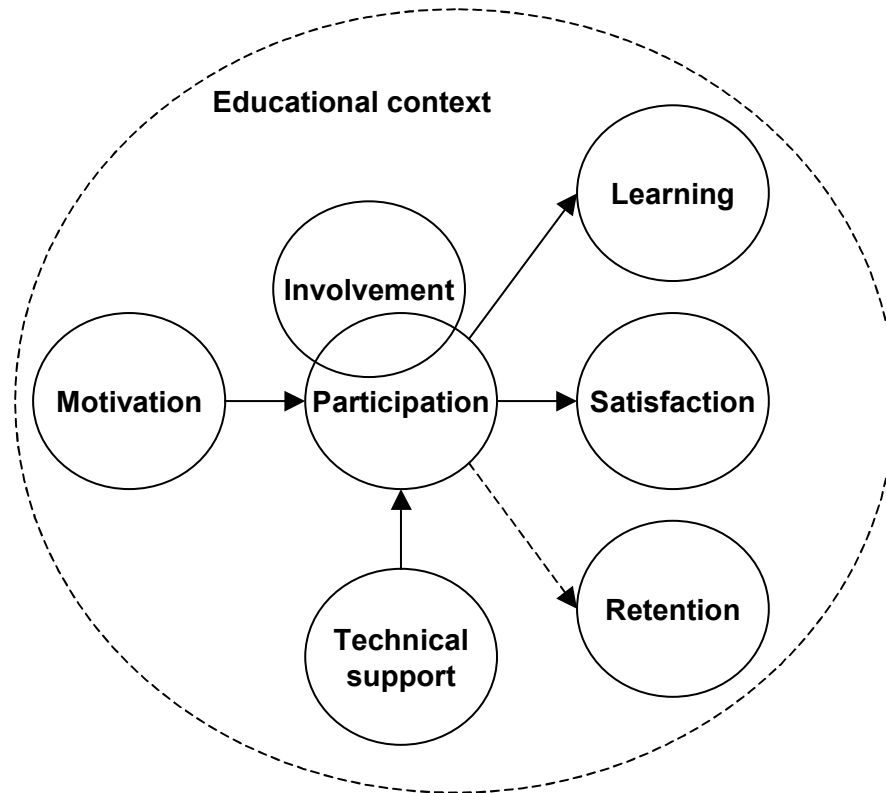

Figure 2.1. An initial model of online student participation and related variables⁷

The review of online student participation and related variables revealed that there is considerable evidence to support that online student participation may affect learning outcomes and student satisfaction positively. This seems especially evident in contexts where students interact and collaborate with peers and teachers, as in the case studies of this thesis. Many researchers advocate that participation may affect retention rates positively although no major empirical study in support of this relationship was identified. It was also found that motivation might be a prerequisite for participation and that definitions of involvement at least partly overlap with the definition of participation used in this thesis.

⁷ It should be noted that the model of Figure 2.1 is a simplification of current research. For example, different researchers have defined the concepts of the figure differently. In further research the relationships among these variables will need to be investigated more thoroughly. For example, it can be hypothesized that student satisfaction may enhance online student participation.

3. Research on online education

This chapter discusses the literature reviews of Paper I and II, and serves the purpose of giving a background to research on online education in general, and the studies of this thesis in particular. The first and second research questions are addressed: Which research approaches and topics underlie research on online education? Which might the implications be for further research? The research approaches that underlie the literature reviews are described and the contributions of the reviews are discussed.

3.1 Background to the literature reviews

The intended reader for a literature review is often researchers within a particular field (Chen & Hirschheim 2004; Orlikowski & Baroudi 1991) but may also be practitioners or researchers in other fields (Avgerou 2000). There are two points in the life of a researcher where it is natural to write a literature review (Webster & Watson 2002). Those are when a researcher is very experienced in a stream of research and can “tell their colleagues what they have learned and where the field can most fruitfully direct its attention” (p. xiv) and when having completed a literature review before embarking on a project. My personal reasons for conducting reviews were to identify research questions that address issues where research is needed and make a contribution since there are few reviews that classify a large number of research papers according to research approaches or topics on technology-supported learning. As is discussed below, detailed concept matrixes were developed since the contribution was by systematically reviewing the area and not by writing from experience.

3.1.1 Research design

It has been argued that literature reviews should be focused on a topic and not a small sample of journals, specific research methods, geographic regions or researchers (Webster & Watson 2002). However, many previous reviews have focused on specific journals. For example, Orlikowski and Baroudi (1991) reviewed research from 1983 to 1988 in four IS journals to reveal the philosophical assumptions of IS researchers, Swanson and Ramiller (1993) reviewed submissions to the Information Systems Research journal from 1987 to 1992 to gain an insight into the IS field, and Whitley and Galliers (2007) reviewed submissions to the European Conference on IS from 1993 to 2002 to describe European IS research. Webster and Watson (2002) quote an anonymous reviewer who “can’t see the justification for searching by journal instead of searching by topic across all relevant journals” (p. xvi). This is possible when focusing on a specific topic, such as the review on IM research that was presented in the previous chapter. However, broader reviews can aid to reveal gaps and trends of research. It would not have been possible to complete such a review if it was not delimited to specific journals during a time period.

The following criteria were developed to guide the selection of journals: (1) the journals should have been around for as long as possible (the selected journals had published between 29 and 43 volumes); (2) the journals should be published by well-known publishers; and (3) the articles should be double blind reviewed. It was decided to focus on four journals, Computers & Education, Educational Media International, Journal of Educational Computing Research and Journal of Educational Media, during 2000 to 2004. We also considered the leading IS journals but although most of them publish research on technology-supported learning, they include too few such articles, which makes it difficult to reveal gaps and trends of research.

Webster and Watson (2002) recommend that a concept matrix is compiled as articles are examined. For each of the comparisons that were made in the review such a matrix was developed. To give an idea of the design of the matrixes, Table 3.1 illustrates the first five rows of a matrix used when deciding whether the articles in the Educational

Media International journal focused on asynchronous, synchronous or both types of communication.

Table 3.1. Example of a concept matrix

Article	Asynch.	Synch.	Mixed
Tuovinen (2000)		√	
Hedberg & Corrent-Agostinho (2000)	√	√	√
Offir & Lev (2000)	√		
Ewing (2000)	√		
Hung & Der-Thanq (2001)	√	√	√
...

Drawing on the matrixes for the four journals, it was then possible to summarize which type of communication the research articles focused on. Table 3.2 shows the number of articles in each category and the total percentage of the articles they represent, for each year and overall. The articles were classified as asynchronous or synchronous and those that discussed both types of communication were also classified as mixed communication. Therefore, the sum of percentages is expected to exceed 100%. The data indicate that it has become relatively less common to study synchronous and mixed approaches more recently.

Table 3.2. Articles classified according to type of communication

Media	2000 (%)	2001 (%)	2002 (%)	2003 (%)	2004 (%)	Total (%)
Asynch.	17 (74)	16 (89)	17 (94)	28 (78)	18 (82)	96 (82)
Synch.	9 (39)	9 (50)	2 (11)	11 (31)	4 (18)	35 (30)
Mixed	3 (13)	9 (50)	2 (11)	5 (14)	2 (9)	21 (18)

3.2 Summary of Paper I and II

Paper I has the title *An examination of research approaches that underlie research on educational technology: A review from 2000 to 2004* and Paper II has the title *Computer-mediated communication in education: A review of recent research*. Both are reviews of recent research and were co-authored by Christina Keller.

In Paper I, it was argued that it is important to reflect on the research approaches that underlie research since the choice of approaches

affects what a research field can achieve. The paper reviewed the research approaches that underlie research on educational technology. Educational technology is a broad term that encompasses online education but other types of applications as well, such as self-directed learning by using educational multimedia. The term *research approach* was assumed to encompass both research methods (e.g., qualitative) and different types of research papers (e.g., conceptual).

In Paper II, it was argued that it might be useful to categorize recent research since the field of research on CMC in education is a relatively new area and, hitherto, few have summarized which research approaches and topics that have been emphasized. The paper reviewed the approaches that underlie research and the research topics that have been addressed. By doing this, researchers may be better prepared for the future by uncovering areas where there is a lack of research. Thus, both papers aimed to reveal common research approaches and Paper II also aimed to reveal which topics that have been most and least heavily researched. Both papers examined research articles published in four journals, *Computers & Education*, *Educational Media International*, *Journal of Educational Computing Research* and *Journal of Educational Media* between 2000 and 2004.

All full-length articles were included in the study of Paper I while editorials, book reviews and conference summaries were excluded. In total, 660 articles were selected. The articles were classified according to the following categories: empirical vs. non-empirical, qualitative vs. quantitative vs. mixed method, method vs. non-method and conceptual-analytical vs. opinion vs. applied concepts. For an article to be included in the study of Paper II it had to address some aspect of CMC in education. In total, 117 articles were selected. The articles were classified according to the following categories: empirical vs. non-empirical, qualitative vs. quantitative vs. mixed method, blended vs. distance education, asynchronous vs. synchronous vs. mixed communication, text vs. audio vs. video communication, using vs. building CMC systems and learner-learner vs. learner-teacher vs. teacher-teacher interaction.

The study of Paper I revealed that research has increasingly been dominated by empirical articles that adopt a pluralistic approach, both regarding research methods but also different types of non-empirical

research. The focus has been to apply rather than develop frameworks, concepts and theory. Notably, published articles in the four journals examined differed more widely than the aims and scopes of the journals led us to believe. This thesis responds to the lack of theory building efforts by proposing frameworks, concepts and comprehensible theories.

The study of Paper II revealed that research on CMC in education has been dominated by empirical articles that adopt a pluralistic approach, which investigate asynchronous text-based CMC by students and teachers engaged in blended education. The paper was concluded by exemplifying how these findings may guide future research: (1) research is needed that build theory; (2) research is needed on new and emerging communication media; (3) research is needed on synchronous communication; and (4) research is needed on the combination of different media in blended education. Notably, this thesis responds to all four of these suggestions, although it focuses on online education rather than blended education.

3.3 Analysis frameworks

Analytic theories analyse “what is” as opposed to explaining causality or attempting predictive generalizations (Gregor 2006, p. 622). Some prefer labelling this theory type as descriptive (Fawcett & Downs 1986). However, Gregor (2006) argues that this “is not entirely appropriate as this class of theories goes beyond basic description in analyzing or summarizing salient attributes of phenomena and relationships among phenomena” (p. 623). Common variants of theory for analysing are classification schemas, frameworks and taxonomies (Gregor 2006).

Two analysis frameworks were developed to classify and analyse research. In Paper I, a framework for classifying research approaches within the field of educational technology was presented (Table 3.3). In Paper II, a framework for classifying methodologies and research topics in research on CMC in education was presented (Table 3.4). Drawing on these findings, promising areas for further research and research approaches, which this thesis responds to, were suggested.

Table 3.3. A framework for classifying research approaches within the field of educational technology (table structure adapted from Gregor 2006)

Overview	
	A framework for classifying research approaches within the field of educational technology. The framework is intended to serve as a simplifying device for revealing the research approaches that characterize research on educational technology and is expected to be able to be used in different points of time.
Component	Instantiation
Means of representation	Words, tables, diagrams.
Primary constructs	<i>Types of research papers:</i> empirical vs. non-empirical, conceptual-analytical vs. opinion vs. applied concepts. <i>Research methodologies:</i> qualitative vs. quantitative vs. mixed method and method vs. non-method.
Statement of relationships	Not present.
Scope	Research papers published in four journals (Computers & Education, Educational Media International, Journal of Educational Computing Research, and Journal of Educational Media) during 2000-2004.
Causal explanations	Not present.
Testable propositions	Research on educational technology is increasingly dominated by empirical papers that adopt a pluralistic approach, both regarding research methods but also different types of non-empirical research. The focus of research has been to apply rather than develop frameworks, concepts and theory. The research approaches of the articles differed from what was indicated by the aims and scopes of the journals.
Prescriptive statements	Not present.

Table 3.4. A framework for classifying methodologies and research topics in research on CMC in education (table structure adapted from Gregor 2006)

Overview	
	A framework for classifying methodologies and topics of research on CMC in education. The framework is intended to serve as a simplifying device for revealing the methodologies and research topics that characterize research on CMC in education and is expected to be able to be used in different points of time.
Component	Instantiation
Means of representation	Words, tables, diagrams.
Primary constructs	<i>Research methodologies</i> : empirical vs. non-empirical and qualitative vs. quantitative vs. mixed method. <i>Research topics</i> : blended vs. distance education, asynchronous vs. synchronous vs. mixed communication, text vs. audio vs. video communication, using vs. building CMC systems and learner-learner vs. learner-teacher vs. teacher-teacher interaction.
Statement of relationships	Not present.
Scope	Research papers on CMC in education published in four journals (Computers & Education, Educational Media International, Journal of Educational Computing Research, and Journal of Educational Media) during 2000-2004.
Causal explanations	Not present.
Testable propositions	Research on CMC in education is dominated by empirical papers that adopt a pluralistic approach. The focus of research has been to investigate the use of asynchronous text-based CMC systems by students and teachers engaged in blended education.
Prescriptive statements	Not present.

In short, the literature reviews indicated the approaches that underlie research and the review of research on CMC in education also identified the topics that have been most and least heavily researched. These reviews are among few quantitative trend analyses on educational technology and CMC in education. Two exceptions are Klein's (1997) review of the development section of the journal *Educational Technology Research and Development* and Hew, Kale and Kim's (2007) recently published review of topics, methods and settings in three instructional technology journals from the year 2000 through 2004.

The literature reviews may serve as a basis for reflection upon the current state and future development of research in general and research approaches in particular. Moreover, researchers that are looking for a research topic may use the review of CMC in education as support when searching for areas where research is needed. Finally, the reviews may be of interest to researchers in adjacent fields and practitioners interested to know more about research on online education.

3.4 Quality of the reviews

The literature reviews of Paper I and II were limited to an analysis of articles from four journals between 2000 and 2004. A legitimate question to ask is whether doing this resulted in an accurate view of the research field, and how it developed, during these years. The construct validity of the reviews, i.e. "establishing correct operational measures for the concepts being studied" (Kidder & Judd 1986 in Yin 2003, p. 34) seems not to be an issue since the categories were well-established in previous reviews and research. However, one may question the generalizability of the studies, i.e. whether the results are in accordance with "reality" (Merriam 1994). To address this question, it was decided to choose journals that have been around for as long as possible, are published by well-known publishers and are double blind reviewed. There are many other journals that fulfil these selection criteria. In the end, since no well-established journal ranking list exists, the selection of journals was somewhat subjective since it was based on our opinion of appropriate journals for the review.

3.5 Summary and conclusions

In this chapter, two literature reviews that give a background to the remaining part of the thesis were discussed. They were conducted by systematically reviewing recent research. The reviews showed that recent research has been dominated by empirical articles that adopt pluralistic research approaches. However, there has been a lack of theory building efforts, and a lack of research on emerging media and synchronous communication, and the combination of different types of communication. This thesis responds to these drawbacks by contributing towards building theory, including frameworks and concepts, on how synchronous communication, as a complement to asynchronous communication, affects student participation in online education.

4. Research approaches

In the papers, the underlying research methods were quite thoroughly discussed in order to make it possible for the reader to understand how the results were obtained. However, because of the expected conciseness of research papers, some issues were excluded and are discussed in this chapter. First, my view on research approaches and theory building is discussed. Then, the research approaches of the case studies (Paper III-V) and the design study (Paper VI) are discussed. Finally, the chapter is summarized.

4.1 Initial reflections

Prior to describing the research approaches of this thesis explicitly, I will discuss the views on ontology, epistemology, methodology and theory building that underlie this thesis. This discussion will hopefully aid the reader's understanding of the view of research approaches that this thesis rests upon.

4.1.1 Ontological and epistemological reflection

I have studied how students use different media to support participation in natural settings. From an ontological perspective, I acknowledge that it was only possible to study parts of what was going on. Thus, of all events that were occurring, only some were actually empirically studied and interpreted, and it is on these events that the conclusions of this thesis rest (Bhaskar 1978; Mingers 2006).

Commonly, authors of epistemological discussions take sides in the debate between positivist and interpretative approaches. The IS field is vastly dominated by positivist research (Chen & Hirschheim 2004; Orlikowski & Baroudi 1991). Surprisingly, few have acknowledged that this decision may be guided by the aim of the research (Chen &

Hirschheim 2004) and what type of theory the researcher seeks to build (Gregor 2006). As revealed in Paper I, it is also likely that other factors, such as editorial policies and dominant views of the surrounding research community, shape underlying ontological and epistemological dimensions.

A closer look at the research questions of this thesis reveals that the underlying epistemology has changed over time. For example, compare the research questions of Paper III and V. Initially, it was investigated how the possibility to communicate synchronous *does* affect participation. However, as the complexity of the relationship between synchronous communication and participation was realized, the research question of Paper V was stated more modestly. Thus, it was investigated how the possibility to communicate synchronously *may* affect participation. Moreover, over time I became more and more interested in investigating *why* and *when* (in what circumstances) synchronous communication *may* affect participation. In doing this, the importance of explaining, rather than merely predicting participation, has been emphasized.

4.1.2 Methodological reflection

The research approaches were chosen on the basis of the research questions, what was already known and what type of theory I wanted to contribute towards building. Quantitative research methodology “typically uses numerical analysis to illustrate the relationship among factors in the phenomenon studied” while qualitative methodology “emphasizes the description and understanding of the situation behind the factors” (Chen & Hirschheim 2004, p. 204). In the literature reviews, it was argued that these two approaches are complementing. If a researcher is interested in how often an IS is used or the attitudes of a large number of users it is natural to use quantitative methods. This can, for example, be used to compare different groups of users through statistical techniques. On the other hand, if the researcher wants to gain an in-depth understanding of why users react in a particular way, qualitative investigations, such as interviews or observations, might be preferable (Kaplan, Farzanfar & Friedman 2003).

Åsberg (2001) writes that the debate of quantitative vs. qualitative research has been overemphasized. He argues that researchers sometimes are interested in words (qualitative data) and sometimes in numbers (quantitative data) and that “numbers and words are both necessary if we are to understand the world” (Miles & Huberman 1994, p. 40). An increasing number of researchers have argued that several sources of evidence should support conclusions since they then become more convincing (Yin 2003) and may provide different dimensions of a phenomenon (Cavaye 1996; Chen & Hirschheim 2004). This can be crucial when investigating “complex phenomena by combining the strengths of different research methods” (Kaplan et al. 2003, p. 35). In this thesis, both qualitative and quantitative research methods have been used. For example, content analysis was used when studying how much text students produced according to three types of exchanges (i.e., information exchange, task support and social support) while interviews were used to address more complex issues such as why, and in what circumstances, students felt that they participated.

I have gradually moved from being an “outside researcher” to an “involved researcher” (Walsham 2006). In the literature review and empirical studies of Paper III-IV, as an outside researcher, I was involved in action to a limited extent. However, in the study of Paper V, I was both a teacher and researcher. Walsham (2006) argues that close involvement is “good for in-depth access to people, issues, and data” and “enables observation or participation in action, rather than merely accessing opinions” (p. 321). These approaches can be used complementarily. As an outside researcher, I found that synchronous communication has the potential to enhance participation. Later, as an involved researcher, I got a more in-depth understanding, of why and in what circumstances participation was enhanced. It needs to be acknowledged that a disadvantage of the latter approach is that the students may have been less honest and open than if, for example, they were interviewed by an outside researcher, even though I guaranteed confidentiality (Walsham 2006).

4.1.3 From data to theory

“Data are not theory” (Sutton & Staw 1995, p. 373) and do not necessarily equal theoretical progress since data can only guide

theoretical development (Gregor 2006). Sutton and Staw (1995) motivate this by referring to Kaplan (1964): “Data explain *which* empirical patterns were observed and theory explains *why* empirical patterns were expected or are expected to be observed” (p. 374). It is commonly argued that theory should include *generalizations*. In the social sciences, the possibility to discern true “laws” is unlikely because of “the very large number of conditions (X_n) that might impact on any outcome (Y)” (Gregor 2006, p. 616). In fact, Lee and Baskerville (2003) argue that conclusions cannot be directly generalized to other settings than in which they have been tested.

The unlikelihood of discerning general “laws” can be addressed by defining the level of generality or scope and by using modal qualifiers. In chapter five, the main theoretical contributions of this thesis are summarized. In doing this, the scope is defined, i.e. “Online learning environments that support both asynchronous and synchronous means of communication”. The following is an example of a modal qualifier, which emphasized that the relationship is not expected to always be true: “Synchronous communication *has the potential to* enhance participation”. A challenge related with this modal qualifier, which is addressed in the sixth chapter, is to strive towards a deeper understanding of in what circumstances the relationship is likely to be true.

Theory is commonly associated with *causality*, i.e. the relation between cause and event. This is especially true for explanatory theory (Gregor 2006). As acknowledged above, it is seldom possible to provide “universal laws” in social science research. This thesis aims to conduct probabilistic causal analysis by, for example, identifying circumstances in which synchronous communication has the potential to enhance participation. Moreover, a cause (e.g., synchronous communication) is not considered as a necessary condition for an event to occur (e.g., enhanced participation) since it is indeed possible to enhance participation without communicating synchronously. For example, Kuboni and Martin (2004) identify support strategies to enhance participation in asynchronous online education.

Traditionally, the word theory in both the natural and social sciences has been primarily used when explaining and predicting something. However, Gregor’s (2006) taxonomy of theory types in IS research

provides a broader view (see Table 4.1). This framework is used when discussing the theoretical contributions of the thesis in the sixth chapter. The distinguishing attribute of the fifth theory type has been expanded. In Paper VI, it was argued for a broader view of this theory type that encompasses the design and improvement of IS *and* IS use (Carlsson 2006).

Table 4.1. A taxonomy of theory types in IS research (adapted from Gregor 2006, p. 620)

Theory type	Distinguishing attributes	Corresponding part of thesis
I. Analysis	The theory does not extend beyond analysis and description. No causal relationships among phenomena are specified and no predictions are made.	Literature reviews of Paper I and II
II. Explanation	The theory provides explanations but does not aim to predict with any precision. There are no testable propositions.	-
III. Prediction	The theory provides predictions and has testable propositions but does not have well-developed justificatory causal explanations.	Case studies of Paper III-IV
IV. Explanation and prediction	Provides predictions and has both testable propositions and causal explanations.	Case study of Paper V, Chapter 6.
V. Design and action	The theory gives explicit prescriptions (e.g., methods, techniques, principles of form and function) for constructing [and using] an artefact.	Design study of Paper VI

The literature reviews (Paper I and II) aimed to contribute by describing and analysing research approaches and topics of recent research. The case studies (Paper III-V) primarily aimed to predict how synchronous communication, as a complement to asynchronous communication, affects student participation, even though some explanations were provided, especially in Paper V. In the sixth chapter, there are more thorough explanations for why synchronous communication seems to have the potential to influence participation positively. Finally, by drawing on the empirical studies and literature,

Paper VI provided design propositions that were developed to guide design and action.

4.2 Studying online student participation

In this section, approaches that commonly underlie research on online student participation are reviewed. Then, social network analysis, an approach that has been argued to be useful for studying relations among online students (Daugherty & Turner 2003; Haythornthwaite 2001) and has been used in the empirical studies, is discussed.

4.2.1 Online student participation

Major findings of research on online student participation were summarized in the previous chapter. However, the review did not give a thorough understanding of how the complex phenomenon of online student participation may be studied. Previous studies on online student participation were used to guide the decision of research methods in this thesis. A literature search by using the Education Resources Information Center (ERIC) database was completed in August 2007. The ERIC database includes well-known journals on educational technology published by organizations such as Elsevier and Routledge and is usually considered as the most important database when identifying such literature (Hertzberg & Rudner 1999). Thirty-one papers on the topic with the terms “participation” or “participate” in the title were identified. A detailed classification of the papers is presented in Appendix C.

Most of the reviewed studies used mixed (58%) or quantitative (35%) methods whilst few relied solely on qualitative data (6%). By iteratively reviewing the articles, the following types of data emerged: the number of messages or units, message or unit quality, student perceptions, message lengths, system accesses or logins, read messages and time spent. Table 4.2 displays the frequencies and percentages of reviewed articles by type of data. It should be noted that most of the studies concerned asynchronous communication (84%). Thus, some of these

data collection methods might be less appropriate for studying synchronous communication.

Table 4.2. The frequency and percentage of reviewed articles by type of data

	No of articles	Percent of articles
Number of messages or units	25	81
Message or unit quality	16	52
Student perceptions	12	39
Message lengths	5	17
System accesses or logins	4	13
Read messages	3	10
Time spent	2	7
Total	31	100

The most common approach has been to count messages or units, for example, to compare the number of messages students in different groups have written. Some of the studies divide messages into fixed units (e.g., words, sentences, paragraphs) or thematic units (e.g., thoughts, ideas). It has been common to analyse the quality of messages or units, usually by categorizing them according to a classification scheme. In this thesis, several of these approaches were combined to achieve an in-depth understanding of participation. These were: number of units (sentences), time spent, unit quality, and student perceptions (see section 4.6 for a discussion of these approaches).

4.2.2 Social network analysis

Social network analysis was used in the studies of the thesis. It is an analysis method appropriate for studying the second part of Wenger's (1998) definition of participation, i.e. "the relations with others that reflect [the] process [of taking part]" (p. 55). Paper IV includes a discussion on social network analysis. The discussion below aims to complement and extend that discussion. It is restricted to the concepts of importance in the thesis.

The social network approach has been used to study perceived online student participation. The participants of an online course, including

students, teachers and other actors, can be viewed as part of an interpersonal power system, where some actors have more influence than others (Salanick & Pfeffer 1974). It is likely that students will listen to their teacher, but it is also probable that they will listen more carefully to some of their peers. Students may give more information to peers or less, but it may also be experienced as they provide more or less useful information. Differences in reporting of relationships are often found in situations where an actor is perceived as a prominent figure of a network (Haythornthwaite 1996). Thus, social network analysis may help unveil subtle dimensions of participation in social networks, which would not be apparent if relying solely on simplistic measures, such as counting the number of written messages.

Jacob Moreno (1934) was probably the first to conduct studies on social networks. In the 1930s he founded sociometry, “the measurement of interpersonal relations in small groups” (Wasserman & Faust 1994, p. 11). It is a precursor to social network analysis, which has been developed ever since and now provides a set of techniques for understanding patterns of relations between and among people, groups and organizations (Garton, Haythornthwaite & Wellman 1999). It is mainly useful when studying relational data (Scott 1991).

In social network analysis, *relations* describe particular types of resource exchange between *actors*. A *social network* is defined as “a finite set or sets of actors and the relation or relations defined on them” (Wasserman & Faust 1994, p. 20). The more pairs of actors that are connected in the network, the higher the network *density*. It needs to be clarified that a high network density is not enough in order for learning to occur in networks (Hansen 2002). Obviously, this depends on what the pairs of networks actually communicate about.

The resources exchanged among pairs of actors can be of many types, including tangibles such as goods, services, or money, or intangibles such as information, social support, or influence (Haythornthwaite 1996, p. 323). Thus, the *content* of relationships may vary. For example, some students may mainly exchange information while others may also support each other socially. *Ties* are distinguished from relationships – the term describes the aggregate of relationships or connections between pairs (Haythornthwaite 1996).

As illustrated in Figure 4.1, there are four levels of measurement in relational or social network data. In the empirical studies, what Scott (1991) labels type 3 and type 4 data were collected. By collecting these types of data, it was possible to not only conclude whether a particular type of relation exists between two students but also the direction of it.

		Directionality	
		Undirected	Directed
Numeration	Binary	1	3
	Valued	2	4

Figure 4.1. Levels of measurement in relational data (Scott 1991, p. 48)

Social network data is initially organized in *sociomatrices*. These may then be used for quantitative analysis (e.g., calculating network densities) or drawing *sociograms* or *graphs*. Sociograms have been of great illustrative importance ever since the 1930s (Moreno 1934). The main weakness is the difficulty to draw comprehensible diagrams for large sets of actors (Scott 1991). Figure 4.2 shows a sociogram from Paper III. Each *node* represents a student and the arrows show which others he or she is tied to. As noted above, ties may be directed and therefore arrows, instead of just lines, were used. The strength of the ties, measured as frequency of communication, is denoted by thin (weak ties) and thick (strong ties) lines. This is not the most common approach. Standard works on social network analysis (Scott 1991; Wasserman & Faust 1994) suggest that a number is assigned to each line to denote strength. However, this made the figure difficult to interpret. The sociogram in the figure is an example of a *whole network* since it illustrates the ties of all class members. The ties of specific actors in a larger community, *ego-centered networks*, may also be studied (Garton et al. 1999). In the empirical studies it is discussed in more detail how social network data was collected and analysed.

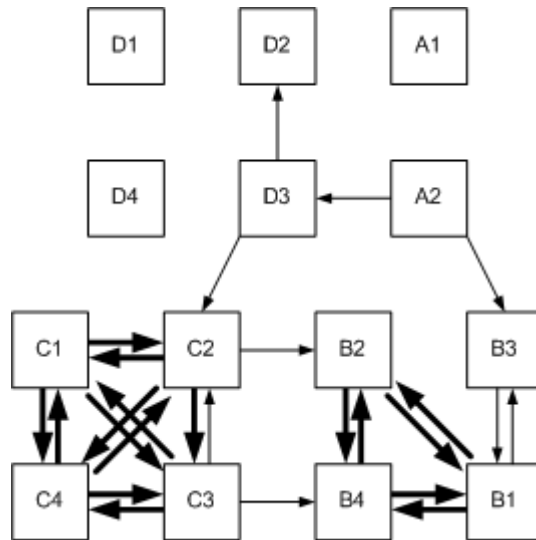

Figure 4.2. Example of a sociogram (from Paper III)

In the next section, the case study approaches of Paper III-V are discussed. As mentioned above, these studies used several of the approaches for studying online student participation discussed above, and also adopted social network analysis methods.

4.3 Case study research

Empirical research articles, including case studies, have become more popular among IS researchers recently (Chen & Hirschheim 2004). A case study is an empirical inquiry that investigates a contemporary phenomenon within its real-life context, especially when the boundaries between phenomenon and context are not clearly evident (Yin 2003, p. 13). Lee (1989) argues that the case study methodology should be considered as scientific and efficient as methods used in the natural sciences such as quantitative methods.

Case study research is particularly appropriate when conducting evaluations (Robson 2002), as done in the empirical studies, and for design science research (van Aken 2005), since the method is flexible. The IS field has a long tradition of evaluating IS by identifying what contributes to IS success and failure (Beynon-Davies, Owens & Williams 2004). There are at least three types of IS evaluation, i.e. evaluation of the utility, functionality and usability of IS (Willcocks

1996). This thesis is mainly concerned with the utility of IS by investigating whether synchronous communication in online education may enhance student participation. However, in doing this, the functionality and usability of communication media will also be taken into account. For example, if a medium does not have the functionality that students require, or if students do not perceive a medium as useful, it is less likely that the medium can be used to enhance participation.

Benbasat, Goldstein and Mead (1987) argue that there are three reasons why IS researchers may choose the case study research strategy. Firstly, IS can be studied in their natural setting. According to sociocultural learning theory, learning cannot be understood without reference to the social context, which in this study is the use of CMC in authentic learning environments (Bonk & King 1995; Vygotsky 1978). Secondly, “the nature and complexity of the processes taking place” (Benbasat et al. 1987, p. 370) can be better understood. The processes that need to be analysed in order to answer the research questions of the empirical studies are indeed complex. Thirdly, it is appropriate for areas in which few studies have been carried out. Hitherto, few have studied IM use (Paper III and IV) and rather few have studied the use of mixed media approaches (Paper V) in online education.

In some situations specific research strategies are advantageous (Yin 2003). Yin suggests that case study research is appropriate when “a ‘how’ or ‘why’ question is being asked about a contemporary set of events, over which the investigator has little or no control” (p. 9). It was deemed important not to try to control behavioural events in order to study how, why and when synchronous communication may affect participation in the natural setting of online students. Drawing from the arguments put forward above, it was decided that case study research would be the method of the empirical studies.

A central question was whether to include one or several cases in the studies. It has been argued that multiple-case designs may be preferred over single-case designs since there are analytical benefits when having several cases. Conclusions drawn from several cases that are studied in contexts that differ are more powerful because it may be possible to generalize (Benbasat et al. 1987; Yin 2003). However, an obvious advantage of the single-case design is that the researcher can analyse a particular case more thoroughly. The empirical studies attempt to

answer complex questions that require a deep understanding of the context. This motivates focusing on one case (Cavaye 1996; Yin 1989).

In the studies of Paper III and IV, little was known beforehand, and therefore it was decided to focus on one case setting in order to get a deeper understanding of participation by IM and other means of communication in online education. In Paper V, however, more was known beforehand. For example, more than ten comparative studies of text-based asynchronous and synchronous communication were identified. Therefore, it was decided to include two cases in order to compare a smaller and larger group, and to present more general conclusions. A strength of Paper VI is that it draws on all case studies and previous research as a foundation for proposing more general design propositions.

4.4 Design science research

Research can be classified in different ways. Herbert Simon (1988), in his book *The Science of the Artificial*, distinguishes between “natural sciences” and “artificial sciences”. Natural sciences focus on how natural and social “things” are, while artificial or design sciences focus on how to design artefacts to fulfil certain norms. Recently, the design science approach has received increased attention in both IS and education research (Mor & Winters 2007; Walls, Widemeyer & El Sawy 2004). It may be particularly useful in research on online education, where the interest is not only on the process of online learning but also on how activities and technologies can be designed to support learning (Mor & Winters 2007). In Paper VI, a design science approach was adopted in order to develop design propositions designated for practitioners, to support decisions on when to use synchronous communication in online education.

Design science research is concerned with theory for action, i.e. “how to do something” (Gregor 2006). Van Aken (2005) argues that the core mission of a design science is “to develop valid knowledge that can be used by professionals in the field in question to design solutions to their field problems” (p. 22). Design science research has been argued to be an essential part of IS research since the field should not only try

to understand how the world is but also how to change it (Iivari in press). Based on the IS field's utilization and relevance problem, it has been suggested that one way to advance the IS field is to increase IS design science research (Hirschheim & Klein 2003; Iivari 2003), which has led to a growing interest in IS design science research (Walls et al. 2004).

In Paper VI, it was argued that influential IS design research frameworks (Hevner et al. 2004; March & Smith 1995; Walls et al. 2004) focus on the IT artefact *per se* while leaving out people and organizations. However, Carlsson (2006) argues that Simon's view on design science is that it can be more than IT artefact design knowledge that the IS field should develop: "Everyone designs who devises courses of action aimed at changing existing situations into preferred ones" (Simon 1988, p. 129). Consequently, we argued that the aim of IS design science research should be to develop practical knowledge not only for the design and improvement of IS but also for IS use. Our call parallels that of van Aken (2005), who has proposed that management research should develop "field-tested and grounded technological rules" to guide practice. More recently, Gregor and Jones (2007) have argued that design science research should not only concern prescriptions for designing technological products and applications but also for designing methodologies and interventions. Similarly, Baskerville, Pries-Heje and Venable (2007) have argued that the boundaries of IS design science research should be extended to include organizational and social aspects of IS.

The design propositions were developed for a constituent community of practitioners including teachers, managers, administrators and developers of online education. They were grounded on kernel theories, cross-case analyses of the empirical studies of the thesis, and by systematically reviewing similar studies. The propositions were then tested through focus groups with representatives from the constituent community. The reader is referred to the paper for a more thorough discussion on our design science approach.

4.5 Research settings

The aim of the thesis has been addressed in three research settings. The first course of choice was studied in Paper III and IV and was entitled Business English Online (BEO). It was deemed suitable since it included group activities and thus made it possible to study communication among students. One advantage of choosing this course was that a research group already was in the process of conducting a longitudinal study of the course (reported in Lindh et al. 2005, 2006; Lindh & Soames 2004a, 2004b). BEO was investigated in the form of comparative studies. In Paper III, data on student participation for two project groups that adopted IM were compared with two groups that did not. In Paper IV, data on student participation for students enrolled in BEO during 2003 (BEO 03) were compared with students enrolled in BEO during 2004 (BEO 04). Moreover, students characterized as adopters were compared with non-adopters. These three comparisons made it possible to study the use of IM on the individual, group and class level.

In Paper V, two series of online discussions that were part of courses on Knowledge management (KM) were studied. The first case included Swedish and Argentinean students (n=8) and the second case included Swedish students (n=19). The courses were deemed suitable since they included asynchronous and synchronous online discussions with geographically dispersed students who mainly communicated by CMC media. For both cases, data on actual and perceived student participation in asynchronous and synchronous online discussions were compared. Moreover, the first case was compared with the second one.

When designing a comparative study the groups may be naturally occurring or created specifically for the study (Robson 2002). In the empirical studies the groups were naturally occurring. For example, before the studies it was not known which students that would adopt IM or would attend the asynchronous and/or synchronous online discussions. As discussed by Robson, this raises issues about internal validity, which are discussed in section 6.6.

4.6 Data collection

In the case studies it was aimed to build as much as possible on previous studies. This is of particular importance in the research field on learning technology which has been accused of having a lack of cumulativity (Hoadley & Pea 2002). By combining existing theories and experiences with collected empirical data, it may be possible to gain a deeper understanding. For example, instead of re-inventing the wheel and developing new instruments for data collection, I searched for existing ones. The empirical studies especially drew on the work of Haythornthwaite (2000, 2001, 2002) who has surveyed how social networks of distance students interact by using various media. Moreover, as discussed below, measures used in the questionnaires were adapted from previous studies.

An advantage of case studies is that they allow for multiple data collection methods. Ideally, several sources support research findings and conclusions since they then become more convincing (Benbasat et al. 1987; Eisenhardt 1989; Yin 2003). The data collection methods of case studies may be qualitative, quantitative or, as in the empirical studies of this thesis, both. Cavaye (1996) mentions two reasons for combining methods when conducting case study research. First, it enables the building of a fuller, richer description. Mixing both qualitative and quantitative methods has been argued to be an important feature of research on student learning in order to gain a deeper understanding (Morgan 1995). Second, it enables cross-validation of findings through triangulation. Drawing on Wenger's (1998) definition of participation as a complex phenomenon, it was decided to not solely rely on quantitative measures, such as the number of written messages. Data on student participation was collected via questionnaires, diaries, electronic logs and interviews.

Questionnaires were used to survey perceived participation and social networks of students. By doing this, it was possible to examine the two parts of Wenger's (1998) definition of participation, i.e. whether the students felt they took part and the relations they maintained with peers. Previously, quantitative measures on participation have most often been used to compare message or unit frequencies for different groups of students (Arbaugh 2000; Masters & Oberprieler 2004).

However, since the social network approach is most useful when analysing relational data (Scott 1991), complementing questions that aimed to collect attribute data such as students' perceived participation were also included. In order to understand more complex issues such as how and why students felt that they participated in group work and in class, interviews were also conducted.

To a large extent this thesis relies on perceived measures of participation because of two reasons. First, it would not have been possible to compare IM use with all other means of communication, including, for example, face-to-face meetings and the use of the telephone (Haythornthwaite 2000, 2001). Second, it was deemed important to find out whether the students *felt* that they participated rather than to rely solely on simple measures such as how much text each student produced. However, it needs to be acknowledged that it is difficult for students to remember retrospectively the social networks they belonged to. For example, Picciano (2002) found that a "low interaction group perceived themselves to have made a higher number of postings than they actually did and the high interaction group perceived themselves to have made fewer postings than they actually did" (p. 32). Because of the insecurity of retrospectively perceiving communication, it was decided to also use a diary approach in Paper III and content analysis in Paper V. An advantage of using diaries is that the students were asked to continuously document their conversations with peers while an advantage of the content analysis approach is the possibility to analyse what was actually written.

Data from the questionnaires, diaries and electronic logs helped answer questions typically addressed when analysing online participation and social networks such as who talked to whom, about what, how often, how much and using which means of communication. These approaches were complemented by interviews. One difference between interviews and more structured data collection methods such as questionnaires is that interviews are guided by conversation rather than structured queries. It is possible to discuss facts of a matter, but more importantly, the interviews were conducted to gain an understanding of the respondents' opinions about events (Yin 2003). Thus, more complex questions such as the following ones could be addressed: How do you think that IM affected your participation in the course? Why do

you think that you did not use IM more actively? Did you feel that you had a closer relation with the other students in the asynchronous (discussion board) or synchronous (chat) online discussions? Why? Below, the process of data collection is described in detail.

4.6.1 The process of data collection

In this section the data collection process of the empirical studies and design study is described chronologically to illustrate that the data collection instruments were refined iteratively. Note that the studies of Paper III and IV were completed in parallel. Table 4.3 summarizes the data collection process.

Table 4.3. The process of data collection

Paper	Participants	Quest.	Interv.	Diaries	Electr. logs	Focus groups
III	BEO 04	√	√	√		
IV	BEO 03/04	√	√			
V	KM (Case #1)	√	√		√	
V	KM (Case #2)	√	√		√	
VI	Practitioners	√				√

Paper III and IV

During June to August 2004 a *questionnaire* (Paper IV) was used to collect data on BEO 03 students' perceived participation and social networks. The measure on students' perceived participation included six items and was adapted from a questionnaire developed by Webster and Hackley (1997), and complemented with additional items from Haythornthwaite (2000). All items reflected whether students felt they were taking part and maintained relations with class members. Four categories of social network data were also collected; information exchange, collaborative work, social support and emotional support (Haythornthwaite 2000, 2001). For each of these exchanges students were asked to assess how often they used each mean of communication when interacting with every other student. Network densities were calculated for both weak (monthly communication) and strong (weekly communication) ties for each medium. Network density indicates the

number of pairs connected relative to the maximum possible number of pairs.

The BEO 04 students were asked to keep a *diary* (Paper III) of all conversations over two weeks in November 2004 when they worked with a group project. For each conversation, the students were asked to specify when it occurred, with whom, mean(s) of communication and type(s) of exchanges that described it. When conducting the questionnaire discussed above, the students rarely reported that they engaged in emotional support and therefore this type of exchange was not included. One of the reasons may have been that some students found it difficult to understand how emotional support differed from social support. Also, collaborative work was renamed to task support since some students found it difficult to understand the term collaborative work and how it differs from information exchange. According to Münzer (2003), the three types of exchanges used in the diary, information exchange, social support and task support may be regarded as standard categories when classifying communication in learning communities.

The BEO 04 students were also asked to complete a *questionnaire* (Paper III) in December 2004. The aim was to collect data on their perceived participation. The measure was adapted from the first questionnaire and also complemented with six additional items adapted from Gunawardena & Zittle (1997) and Rovai and colleagues (2004). The items reflected whether students felt they were taking part and maintained relations with class members. The questionnaire also asked students to assess the number of hours spent interacting with content and other students. In doing this, interaction with content was taken into account since it has been argued as one of the two central dimensions of participation (Bento & Schuster 2003) and a defining characteristic of education (Moore 1989).

In January and February 2005, the BEO 04 students were asked to complete another *questionnaire* (Paper IV). It was similar to the questionnaire completed by BEO 03 students since the two classes were to be compared. However, it also examined prior use of IM systems and self-reported number of hours spent interacting with content and other students.

During January and February 2005 six *interviews* (Paper III and IV) were conducted with BEO 04 students to get a richer view of how the IM system was used as compared with other media. Students were also asked questions on how IM might have affected participation and opinions on using IM to support group work (Paper III) and class work in general (Paper IV). The data from the interviews were recorded and transcribed and then categorized according to the research questions and depending on whether the particular student was classified as an IM adopter or non-adopter. A weakness of recording interviews is that it is not possible to “capture the tacit, non-verbal elements of the interview” and that interviewees may become “less open and truthful” when being recorded (Walsham 2006, p. 323). The first of these weaknesses is probably the most problematic, especially since the interviews were conducted by telephone because of the geographic dispersion of students.

Paper V

Paper V included two cases. The first case was a small group of Swedish and Argentinean students (n=8), and the second case was a larger group of Swedish students (n=19). In April and May 2005, and October and November 2005, *electronic logs* for the first and second cases were collected. Both sets of logs included two asynchronous and two synchronous online discussions. Since the discussions were electronically logged, the actual communication could be analysed and compared with perceived participation and interpersonal relations collected through questionnaires described below. In doing this, the study could draw more powerful conclusions since data were triangulated. This is of particular importance when studying CMC since perceived interaction and actual interaction have been reported to differ (Picciano 2002). Moreover, as acknowledged in Paper III and IV, the students and the researcher may have different views of whether a conversation was giving, for example, social support (Haythornthwaite 2001).

During April and May 2005, the students were asked to complete a *questionnaire* following each online discussion for the first case and over October and November 2005 for the second case. It included a measure on students’ perceived participation adapted from the

questionnaire of Paper III conducted in December 2004. Students were also asked to answer, whether they felt they had exchanged information, task support or social support, with each other student.

Interviews with four students were conducted during May and June 2005 for the first case, and with eight students during November and December 2005 for the second case. The aim was to get a richer view of participation and student opinions of asynchronous and synchronous communication. The data from the interviews were recorded and transcribed and then categorized according to the research questions and depending on whether it concerned asynchronous or synchronous communication, or were of a more general character.

Paper VI

Finally, as part of Paper VI, *focus group sessions* were conducted during March and April 2007 to test design propositions that were developed to support decisions on when to use synchronous communication in online education. A brief description of the propositions was published in LearningNet (Hrastinski & Keller 2007), which is an e-paper funded by the Swedish Agency for Networks and Cooperation in Higher Education. In the article, practitioners with experience of supporting synchronous communication, as a complement to asynchronous communication, in online education were invited to participate in focus groups where the propositions were critically discussed. Thirteen experienced teachers, managers, administrators and developers of online education participated in three focus groups, labelled the teachers, the experts and the mixed group. Krueger (1994) argues that focus groups are appropriate for evaluating the effect of interventions in social contexts and, thus, seemed appropriate for evaluating design propositions. The paper drew on the previous empirical studies and also used data from a *questionnaire* conducted in January 2006 for a related study on learning styles, age and perceptions of online discussions (Keller & Hrastinski 2006). The questionnaire aimed to investigate students' perceived participation retrospectively after the second KM case had been completed.

4.7 Summary and conclusions

Initially, underlying ontological, epistemological and methodological issues, and my view on theory building were discussed. It was suggested that researchers should be flexible and let research approaches be guided by the research questions, what is already known and the type of theory the researchers aims to build. This is reflected by the papers of this thesis, which have adopted both qualitative and quantitative methods and have aimed to contribute towards building different types of theory, i.e. analysis theory, predictive and explanatory theory, and theory for design and action.

The benefits and challenges of the main research approaches that underlie this thesis, i.e. case study research and design science research, were discussed. The literature reviews (Paper I and II) informed the research approaches and choice of topics in the case studies (Paper III-V), which in turn laid the foundation for the design paper (Paper VI). It was also discussed how online student participation can be studied by summarizing recent research approaches on online student participation and by discussing the social network approach.

The chapter builds on the theoretical background, where it was argued that online student participation should be considered as a complex phenomenon. This motivates the use of several complementary data collection methods that jointly contribute in understand how, why and when, synchronous communication affect participation. The data collection methods included measures on perceived participation (questionnaires, diary, interviews and focus groups) and were triangulated with content analyses of actual participation.

5. Summary of the empirical and design studies

In this chapter the remaining four papers of the thesis are summarized. Both Paper III and IV examine IM use and therefore these papers are summarized jointly. Paper III-V are in line with the traditions of behavioural science while Paper VI is inspired by design science (Simon 1988).

5.1 Paper III and IV

Paper III has the title *The relationship between using an informal synchronous medium and participation in online group work: An explorative study* and Paper IV has the title *Introducing an informal synchronous medium in a distance learning course: How is participation affected?* Both papers addressed what has been argued as the most important challenge of online education, to enable student participation. In addressing this challenge, it was examined whether IM, commonly used to support informal and synchronous communication, enabled student participation. The medium might be useful in addressing the lack of informal and social communication of online education. It may be questioned whether a medium can in fact be labelled as informal or synchronous. A medium may be preferable over another in supporting informal or synchronous communication but in the end it is the users that decide how a medium is to be used (Hrastinski 2007a).

Paper III aimed to evaluate whether the use of an IM system may support student participation in online group work. Groups that adopted the IM system were compared with groups that did not. Several measures on participation were compared; social network data, students' perceived participation, and time spent communicating and working with content. The social networks of the adopters were slightly denser, i.e. the adopters communicated with even more other students.

Such a difference was identified for task support and information exchanges that occurred more than weekly and social exchanges that occurred at least once. IM complemented rather than replaced e-mail. The adopters were also related with a stronger sense of perceived participation as compared with the non-adopters. Finally, the adopters seemed to spend more time working with content and communicating interpersonally. In sum, the study indicated that the groups that adopted the IM system operated with a higher level of participation⁸ than those who did not.

Paper IV aimed to evaluate whether the use of an IM system might support student participation in an online course. Two comparisons were made. First, an offering of a course from 2003 where the emphasis was on asynchronous communication, was compared with an offering of the same course in 2004, in which an IM system was used. Two measures on participation were compared, social network data and students' perceived participation. When comparing the network densities it was found that the network of the 2003 offering was denser than that of the 2004 offering. All densities when including all media, except for monthly information exchanges, were lower for the 2004 offering. The students' perceptions of participation confirmed this finding.

The second comparison was for students that adopted IM and those that did not. Three measures on participation were compared, perceived participation and time spent communicating and working with content. The adopters were related with higher means for perceived participation than the non-adopters. Furthermore, the adopters spent more time working with content and communicating interpersonally. Since the results of the two comparisons contradicted each other, it was argued that further research is needed. However, in the paper and in the next chapter it is reflected on why these results may have been obtained.

⁸ "A higher level of participation" simply refers to the fact that the measures listed above indicated more favourable outcomes.

5.2 Paper V

Paper V has the title *The potential of synchronous communication to enhance participation in online discussions*. Various types of CMC have commonly been adopted in educational settings, especially in online education. Few researchers have addressed how to use different CMC media, although this is a difficult decision for practitioners. Paper V aimed to contribute towards an understanding of this problem by examining how the use of chat, as a complement to discussion boards, affects student participation in online discussions. In addressing this question, it was also explored why synchronous communication, supported by chat, may affect student participation.

Two online classes of different sizes (n=8, 19) that participated in two asynchronous and two synchronous online discussions were compared. Measures on both actual participation, i.e. electronic logs, and perceived participation, i.e. social network data, students' perceived participation and student opinions, were used. The synchronous discussions enabled that students to contribute more, maintained more dense social networks and reported a stronger sense of participation. These discussions were more focused on task and social support when compared with the asynchronous discussions. In the synchronous discussions, the students felt that they worked together, because they were confident that someone would respond to their ideas, and they did not feel restricted to only discussing course content, which seemed to be key factors in enabling participation. In sum, the evidence indicated that using synchronous chat has the potential to affect student participation positively in online discussions, a finding that was especially evident in the smaller class. It was suggested that this may be explained by the fact that the "critical mass" needed to get discussions going in synchronous settings seemed to be lower.

The concepts of *personal participation* and *cognitive participation* were introduced to explain the findings. Personal participation describes the more intense type of participation supported by synchronous communication, while cognitive participation describes the more reflective type of participation supported by asynchronous communication. The first type seems to better support less complex information exchanges, including task support and social support

exchanges, while the second type seems to better support reflection and discussion of complex ideas. The concepts of personal and cognitive participation are discussed more thoroughly in section 6.2.

5.3 Paper VI

Paper VI has the title *An initial design theory on when to support synchronous communication in e-learning environments* and was co-authored by Christina Keller and Sven Carlsson. Researchers and practitioners commonly agree on the benefits of asynchronous CMC, i.e. promoting reflection and discussions of complex issues. However, conclusions on when it is beneficial to use synchronous CMC are inconclusive. In order to address this problem, design propositions on when to support synchronous communication, as a complement to asynchronous communication in online education, were suggested. The propositions were grounded on social theories of learning (Wenger 1998; Vygotsky 1978) and the cognitive model of media choice (Robert & Dennis 2005) as kernel theories, cross-case analyses of the studies of Paper III-V, and by systematically reviewing similar studies. The identified constituent community included teachers, managers, administrators and developers of online education.

Six design propositions were suggested: (1) If you want to enhance participation in smaller groups, then support synchronous communication as a complement to asynchronous communication, (2) If you want to enhance “personal” participation, then support synchronous communication, (3) If you want to enhance task support exchanges, then support synchronous communication, (4) If you want to enhance social support exchanges, then support synchronous communication, (5) If you want to enhance weak class-wide relations among students, then support “formal” synchronous communication, and (6) If you want to enhance strong group-wide relations among students, then support “informal” synchronous communication.

The propositions were tested in focus group discussions with practitioners with experience of synchronous CMC in online education. We identified strong support for the first and second propositions, and quite strong support for the third, fourth and fifth propositions. The

sixth proposition received limited support. We argued that the lack of evidence might be because this proposition is of a more innovative nature. The participants of the focus groups felt that it is important to enable strong group-wide relations among students, but they had limited experience of how such relations may be enabled. It was acknowledged that the propositions need to undergo further research to increase saturated evidence and that they need to take better account of different types of synchronous communication.

6. Concluding discussion

In this chapter, the theoretical and practical contributions of this thesis are discussed. The first sections revisit the research questions of the empirical studies and discuss implications for design and practice. This is followed by a discussion of factors that might have affected participation and a retrospective assessment of the quality of the research design. Finally, suggestions for further research and conclusions are put forward.

6.1 Predicting online student participation

In this section, the third and fourth research questions, which mainly aimed to predict the relationship between synchronous communication and online student participation, are addressed.

The third research question was: How does the possibility to communicate synchronously via an IM system affect student participation in online group work? Groups that adopted IM seemed to be characterized by a higher level of participation. In Paper III, two groups that adopted IM were compared with two groups that did not. It was found that the adopters were related with a stronger sense of perceived participation, were characterized by slightly denser social networks and spent more time working with content and communicating with peers. All groups used e-mail for group communications to a similar extent but the adopters also used IM.

The fourth research question was: How does the possibility to communicate synchronously via an IM system affect student participation in an online course? Individuals that adopted IM seemed to be characterized by a higher level of participation but this was not the case for the class in general. When comparing two offerings of BEO, where the first was delivered asynchronously and the second was complemented with IM, social network densities and a measure on perceived participation indicated

that the first class operated with a higher level of participation. However, when comparing measures on perceived participation, and time spent communicating and working with content, for students that adopted IM with those that did not, it was found that the adopters operated with a higher level of participation. Thus, this question could not be conclusively answered although tentative explanations are provided when discussing influencing factors in section 6.5.

6.2 Predicting and explaining online student participation

In this section, the third and fourth research questions, which aimed to predict and explain the relationship between synchronous communication and online student participation, is discussed.

The fifth research question was: How may the possibility to communicate synchronously via chat, as a complement to asynchronous communication by discussion board, affect student participation in online discussions? Students seemed to be characterized by a higher level of participation in the synchronous discussions, especially in the smaller of two classes (n=8, n=19). The synchronous discussions complemented the asynchronous ones in that students contributed more, felt part of denser social networks and, according to the measure on perceived participation and interviews, the students also felt they participated more actively. As mentioned earlier, the students felt that they worked together, because they were confident that someone would respond to their ideas, and they did not feel restricted to only discussing course content, which seem to be key factors in enabling participation. A related finding was identified in a paper that was not included in the thesis because of space limitations (Hrastinski 2007b). It was found that different students dominated the discussions by different means of communication and, thus, by also communicating synchronously, participation was enhanced and more equal among students. Explanations for why synchronous communication seemed to affect participation positively are discussed below.

The sixth research question was: Why may synchronous and asynchronous communication enable different types of participation in online education? In Paper

VI, comparative analyses of the empirical studies of this thesis were conducted. It was suggested that perceived participation decreases over time, and this change seems greater for synchronous communication. There were statistically significant drops when comparing the measure of perceived participation at two points in time, i.e. after each discussion had been completed and about two months later when the KM course (Paper V, second case) was finished. Notably, the drop was greater for the synchronous discussions (from 4.0 to 3.4) as compared with the asynchronous discussions (from 3.9 to 3.7). Below, the media naturalness hypothesis (Kock 2005) and the cognitive model of media choice (Robert & Dennis 2005) help in providing explanations for this finding.

The media naturalness hypothesis predicts that *synchronous communication increases psychological arousal* and, similarly, the cognitive model of media choice predicts that *synchronous communication increases motivation*. The model of Figure 2.1 suggests that motivation may positively influence participation. Kock argues that each element that characterizes “natural” media (e.g., the ability to convey and observe facial expressions and body language) contribute to psychological arousal. However, if these elements are suppressed, a decrease in psychological arousal can be expected. The interviews revealed that many students felt that synchronous communication was “more like talking” as compared with asynchronous communication. It seemed more accepted to exchange social support and discuss less “complex” issues. Consequently, the higher level of participation when communicating synchronously can be explained by the fact that students felt more psychologically aroused and motivated since this type of communication closer resembles natural communication.

Synchronous communication enables monitoring the receiver’s reaction to a message. This makes the receiver more committed and motivated to read the message (Robert & Dennis 2005), which lead to increased convergence on meaning (DeLuca & Valacich 2006; Mason 1998) and decreased communication ambiguity (Kock 2005). Similarly, Woerner, Orlikowski and Yates (2004) argue that synchronous communication may help create a deeper sense of participation in a conversation and Mason (1998) argues that synchronous communication provides motivation for students to keep up with their peers. However, in

asynchronous discussions a majority of the communication can be characterized as questions followed by a response rather than dialogue (Wännman Toresson 2002). These arguments are supported by the interviews of the empirical studies: “Even if I cannot see the person, I write so to speak to the person directly and get an immediate answer” (Interview female #4, Paper V, unpublished quote). It can also be expected that the sender becomes more psychologically aroused and motivated because he or she knows it is likely that a response will be received, as illustrated by the following quote:

Directly when you see that someone comes online you may remember: “Oh, I’ve to talk to him about something.” ... When you send an e-mail you do not know [when you get an answer]. ... If something just pops up spontaneously ... it is easier to talk about it right away. (Interview B4, Paper III)

The media naturalness hypothesis predicts that *synchronous communication decreases cognitive effort* and, similarly, the cognitive model of media choice predicts that *synchronous communication decreases the ability to process information*. From a biological perspective, Kock argues that, because asynchronous communication does not resemble face-to-face communication, extra burden is put on the brain, which has not been designed for asynchronous communication. Robert and Dennis argue that the receiver has more time to comprehend the message since there is not a need to respond quickly. This argument is supported by the interviews of the empirical studies: “In the [asynchronous discussions] it is easier to find some more facts, maybe have a look in a book and do more thorough postings” (Interview Female #6, Paper V, unpublished quote). Similarly, in the empirical studies of Paper III and IV, it was found that students often communicated synchronously when discussing issues categorized as task support while communicating asynchronously when exchanging more “complex” information, such as group reports:

We have had some projects where you have worked in groups and then we have used it a bit to decide when and where and how we should organize our work. It is mostly in that way we have used [IM]. Then, after that we maybe have used e-mail. We have mainly used e-mail to

send stuff but we have organized work by using [IM]. (Interview B4, IM adopter, Paper IV)

As predicted by Robert and Dennis, the students felt they needed time to process information. This finding is also supported by the media synchronicity theory, which was developed for professional online teams. It stipulates that “virtual teams or largely virtual teams may be improved by using media of low synchronicity for conveying information and media of high synchronicity for convergence on shared meaning and switching media as appropriate” (DeLuca & Valacich 2006, p. 341).

According to Kock’s estimate, an exchange of 600 words requires about 6 minutes for complex group tasks in face-to-face settings, while exchanging the same number of words over e-mail would take approximately one hour. In business-to-consumer interactions, asynchronous communication may lead to lower perceived quality and dissatisfaction from customers since they may feel that it is difficult to obtain information about products and services (Kock 2005). However, in the context of online education, it may be interpreted as advantageous to increase cognitive effort since this is expected to enhance learning (Corno & Mandinach 1983). In fact, teachers commonly strive to induce deep rather than surface approaches towards learning (Marton et al. 1977). When communicating asynchronously students discuss a lower number of topics but spend more time on each topic.

The cognitive model of media choice predicts that students respond quickly in synchronous settings since they do not want to disrupt the conversation. In the interviews, it was revealed that the focus of the synchronous discussions was on quantity, i.e. trying to write something fast before “someone else will say what I was going to say” (Female #3, Paper V). Directly after the discussions, the level of perceived participation was high, which at least partly can be explained by the fact that the students felt part of a more intense and psychologically arousing experience. However, after having more time to reflect on the discussions, the students seemed to realize the more subtle benefits of asynchronous discussions, e.g. “take part of other students’ reflections and analysis of the literature”, “time to think about your own and others’ postings” and “the possibility to do research before posting”

(Keller & Hrastinski 2006, Open-ended questionnaire, Unpublished quotes).

Factoring the above, the concepts of *personal participation* and *cognitive participation* are used to describe the dimensions of participation that are supported by synchronous and asynchronous communication (see Figure 6.1). Notably, Garrison and Anderson (2003) argue that social and cognitive presence, which in turn are encouraged by teaching presence, are essential elements of online education.

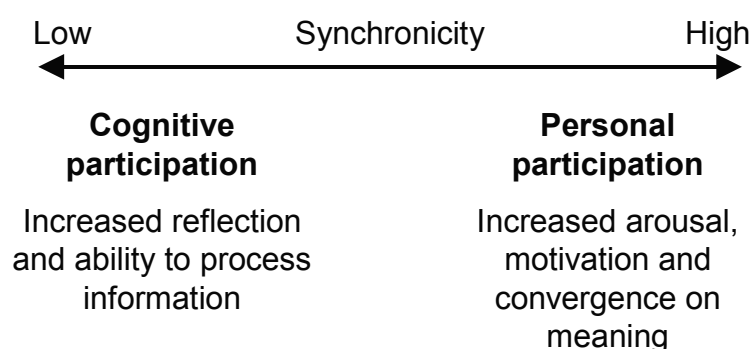

Figure 6.1. The concepts of cognitive and personal participation

In Figure 6.1, it is suggested that, other things being equal, an increase in the degree of synchronicity better supports personal participation while a decrease in the degree of synchronicity better supports cognitive participation. Synchronous communication better supports personal participation because it involves at least the following key elements: (1) increased psychological arousal, (2) increased motivation, and (3) increased convergence on meaning. This type of participation is useful for less complex information exchanges, including task support and social support exchanges. However, a decrease in synchronicity, i.e. asynchronous communication, better supports cognitive participation because of the increased ability to reflect and process information. This type of participation is useful for exchanging more “complex” information.

It should be clarified that a medium may be used differently depending on “how it is used, the context in which it is used and the convenience of its use” (DeLuca & Valacich 2006, p. 340). Thus, even though some media seem preferable for supporting certain types of exchanges, they

are not necessarily used in that way. A benefit of using the concept of synchronicity is that it can describe the *use* of a medium, rather than inherent characteristics of a medium. For example, in some circumstances e-mail might be used to support communication with a lower degree of synchronicity while it might be used to support communication with a higher degree of synchronicity in other circumstances.

6.3 Summarizing the empirical findings

Jointly, the findings suggest that synchronous communication, as a complement to asynchronous communication, has the potential to enhance participation in online education. Paper IV concluded that some individuals and Paper III that project groups adopted IM although it was voluntary to do so. Both individuals and project groups that chose to use IM were related with a higher level of participation. Paper V complemented these results by showing that synchronous use of chat, as compared with asynchronous use of discussion board, was related with a higher level of participation when being used for online discussions, especially in the smaller of two classes. When the sixth research question was discussed above, it was suggested that the difference may be understood through the concepts of personal participation and cognitive participation.

Theory for explaining and predicting “provides predictions and has both testable propositions and causal explanations” (Gregor 2006, p. 620). Table 6.1 summarizes explanations and predictions on how synchronous communication may enhance participation in online education. The scope is delimited to individuals and project groups of online courses and students of mandatory online discussions. In the first setting, students voluntarily chose when and how they wanted to communicate with peers (mainly project groups members) while, in the second setting, students were expected to contribute during a certain time period. Thus, it seems that communicating synchronously has the potential to enhance participation in different contexts, both voluntary or informal and mandatory or formal ones (Hrastinski 2007a).

Table 6.1. Explaining and predicting the relationship between synchronous communication and online student participation (table structure adapted from Gregor 2006)

Overview	
	Synchronous communication, as a complement to asynchronous communication, has the potential to enhance student participation in online education. This proposition builds on a theoretically and empirically supported assumption: student participation enhances learning.
Component	Instantiation
Means of representation	Words, tables, graphs.
Primary constructs	Perceived and actual measures of participation in asynchronous and synchronous communication.
Statement of relationships	Students that adopted IM, a medium commonly used for synchronous communication, were related with a higher level of participation than non-adopters. (Paper III) Project groups that communicated synchronously were related with a higher level of participation than non-adopters. (Paper IV) Synchronous communication by chat enhanced student participation in mandatory online discussions, especially in a smaller class. (Paper V) Synchronous communication may enhance psychological arousal, motivation and convergence on meaning (Section 6.2).
Scope	The studies were conducted as case studies of individual students, project groups of online courses and students of mandatory online discussions.
Causal explanations	Students that adopted IM for synchronous communication used it as a complement to, rather than replacement of asynchronous communication. (Paper III) When communicating synchronously, students felt that they worked together. (Paper V) Synchronous communication better supports personal participation, which complements asynchronous communication that better supports cognitive participation (Section 6.2).
Testable propositions	The relationships and explanations listed above have been and can be further tested.
Prescriptive statements	Not present.

As illustrated by the comparison between the BEO 04 class, where IM was introduced, and the BEO 03 class, simply introducing such a medium will not necessarily enhance participation. Jointly, the empirical studies suggest that communicating synchronously has the potential to, but do not necessarily enhance participation, since it is affected by many factors, some of which are discussed in section 6.5. Most of these factors seem to be fairly constant when comparing the two classes since the teacher agreed to make no conscious changes to the course. However, as will be discussed, two tentative explanations are that the sense of community and the attitudes on participation of students in the two classes might have differed.

The empirical studies suggest that synchronous communication better supported personal participation while asynchronous communication better supported cognitive participation. Thus, it is proposed that each type of communication is related with benefits and limitations, which can be addressed by the taking advantages of both types of communication. One way of doing this is to support both asynchronous and synchronous communication. Another approach is to increase the synchronicity of asynchronous communication by scheduling discussions during a short time period, for example, one or a couple of days (Fähræus & Döös 2006).

6.4 Implications for design and practice

This thesis has strived towards conducting research that is relevant for the constituent community of practitioners, i.e. teachers, administrators, managers and developers of online education. The naturalistic case studies presented many apparent implications for practice. For example, it was found that students voluntarily adopted IM as support for group work in a “real” setting, which tells practitioners that IM might be a useful medium for supporting group work in online education. However, a drawback of conducting research in naturalistic settings is that the findings become affected by influencing factors, some of which are discussed in the next section.

Discussions of the results of the empirical studies have been presented in anthologies (Hrastinski 2006b, 2007a; Keller & Hrastinski 2007). For

example, in Hrastinski (2006b) practitioners were advised on when and how IM may be used to enhance participation in online courses. The most obvious contributions of this thesis for practice have been the design propositions that were developed in Paper VI, which responds to the seventh research question. The propositions have also been described in an e-paper mainly written for practitioners of online education (Hrastinski & Keller 2007).

The seventh research question was: When may synchronous communication be supported as a complement to asynchronous communication in online education? In Paper VI, inspired by design science research, six design propositions, intended to guide practitioners on when synchronous communication may be used, as a complement to asynchronous communication, in online education were proposed (see Table 6.2). Each proposition was described and motivated thoroughly in the paper. It was argued that the output of design science research should be to develop abstract knowledge rather than recipes. Therefore, practitioners are suggested to design online courses based on experience, the specific situation and context, and on the knowledge of the design propositions (Carlsson 2006, van Aken 2004). In Appendix D, examples of implications of the propositions for different groups of practitioners are provided.

6.4.1 Synchronicity and learning outcomes

In Figure 6.1, the concepts of cognitive and personal participation were illustrated. It was suggested that communication of low synchronicity, i.e. asynchronous communication, seems appropriate for inducing cognitive participation while communication of high synchronicity seems appropriate for inducing personal participation. Jointly, the concepts predict that synchronous communication is more useful for less complex information exchanges, including task support and social support exchanges. However, asynchronous communication better supports cognitive participation because of increased reflection and ability to exchange complex information. In this section, I wish to give another example of the implications of these findings for education (see also Appendix D).

Table 6.2. An overview of design propositions for when to support synchronous communication as a complement to asynchronous communication in online education (table structure adapted from Gregor 2006)

Overview	
Design propositions designated for practitioners, to support decisions on when to support synchronous communication, as a complement to asynchronous communication, in online education.	
Component	Instantiation
Means of representation	Words, tables, graphs.
Primary constructs	Perceived and actual measures of participation in asynchronous and synchronous communication.
Statement of relationships	Synchronous communication has the potential to enhance participation in online education (see Table 6.1).
Scope	Online learning environments that support both asynchronous and synchronous means of communication.
Causal explanations	Underlying kernel theories include social learning theories that view participation as critical to the learning process (e.g., Wenger 1998; Vygotsky 1978) and the cognitive model of media choice (Robert & Dennis 2005), which aid in explaining when synchronous communication may be preferred.
Testable propositions	The design propositions may be continuously improved by testing them.
Prescriptive statements (Design propositions)	<p>#1: If you want to enhance participation in smaller groups, then support synchronous communication as a complement to asynchronous communication.</p> <p>#2: If you want to enhance “personal” participation, then support synchronous communication.</p> <p>#3: If you want to enhance task support exchanges, then support synchronous communication.</p> <p>#4: If you want to enhance social support exchanges, then support synchronous communication.</p> <p>#5: If you want to enhance weak class-wide relations among students, then support “formal” synchronous communication.</p> <p>#6: If you want to enhance strong group-wide relations among students, then support “informal” synchronous communication.</p>

There is increased pressure on practitioners of online education to incorporate technology in education, and they need guidance from research on this complex issue (for a more thorough discussion, see Paper VI). Education is commonly guided by learning outcomes, which are viewed as a fundamental building block of educational development. European higher education institutions have agreed on a methodological approach for the expression and description of learning outcomes as part of the “Bologna process” (Adam 2006). These outcomes are defined in terms of knowledge, competences and skills, and range from, for example, being able to describe a theory, towards being able to critically evaluate the value of a theory in different contexts.

The most widely adopted taxonomy of learning outcomes is Bloom’s (1956) taxonomy of developmental levels of learning. It includes six levels: knowledge, comprehension, application, analysis, synthesis and evaluation. The lowest level is knowledge, described as the remembering of content⁹, while the highest level is evaluation, described as the ability to judge the value of material for a given purpose. Guidelines for developing learning outcomes are often inspired by Bloom’s taxonomy. For example, in Sweden, there are three different types of learning categories: knowledge and understanding, skills and abilities, and evaluation ability and attitude (Swedish National Agency for Higher Education, 2007). These categories reflect the developmental levels of learning, as suggested by Bloom. Different online learning activities, which uses different types of communication, can be used as support for different levels of learning (Bender 2003).

⁹ “Knowledge” is an “intrinsically ambiguous and equivocal term” (Newell et al. 2002, p. 3). Bloom (1956) uses the term knowledge to describe remembering of content although the learner might not understand the meaning of content. However, much of the recent literature on knowledge and knowledge management is commonly inspired by Polanyi (1962) who drew on Plato’s definition of knowledge as “justified true belief”.

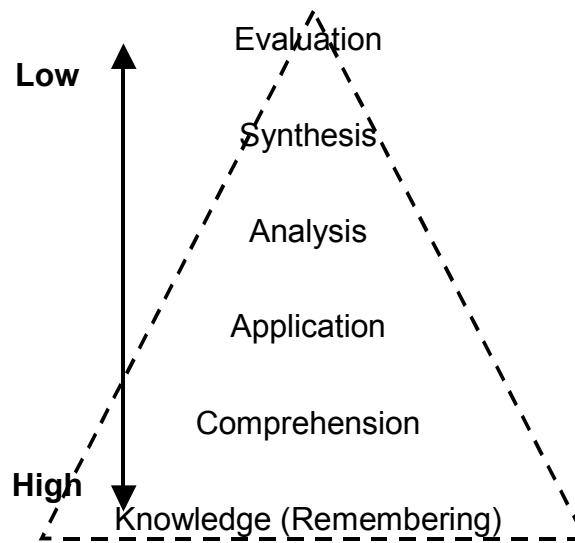

Figure 6.2. Synchronicity and Bloom's (1956) developmental levels of learning

In Figure 6.2, the degree of synchronicity has been combined with Bloom's taxonomy. The results of the thesis suggests that it may be necessary to decrease the level of synchronicity to give students the time they need in order to move from surface towards deep learning, in which reflection is a key ingredient (Bloom 1956; Marton et al. 1977). Meyer (2004) analysed the postings in two doctoral level classes that used a discussion board by using Bloom's taxonomy. She found that 54.3% of the postings were characterized by analysis, synthesis and evaluation. The findings of this thesis suggest that this figure would have been lower when communicating synchronously, since students have less time to respond and engage in thorough analysis, synthesis and evaluation.

Let us assume that we wish students to learn a theory. As part of the "Bologna process", teachers are expected to use level descriptors to describe expected levels of learning (Adam 2006). Drawing on the first two levels of Bloom's taxonomy, the teacher may introduce a definition of the theory and then synchronously make sure that students remember the theory and comprehend it by being able to describe it in one's own words. On the level of application, the teacher may ask students to solve a problem by using the theory – the more complex the problem is, the more time students may need and, consequently, it might be preferable for students and teachers to communicate with a lower degree of synchronicity. When moving towards the three highest

levels of learning, where students may be asked to analyse how a theory differs from other theories, synthesise what the theory might predict or evaluate its usefulness in a certain situation, students will need time to reflect. In such cases this thesis suggests that asynchronous communication, i.e. communication of a lower degree of synchronicity, may be preferable.

6.5 Influencing factors

To a large extent, the focus of this thesis has been on micro-level factors, i.e. participation in small groups of students, rather than paying more attention to wider socio-cultural factors. Hislop (2006) argues that this weakness is typical of empirical studies from the perspective of practice based epistemologies. On the other hand, paying more attention to wider socio-cultural factors might have led to a limited understanding of how, why and when students participate online. In this section, factors that may influence participation are acknowledged and discussed (see Figure 6.3). Then, the key influencing factors and their implications on micro and macro levels are discussed.

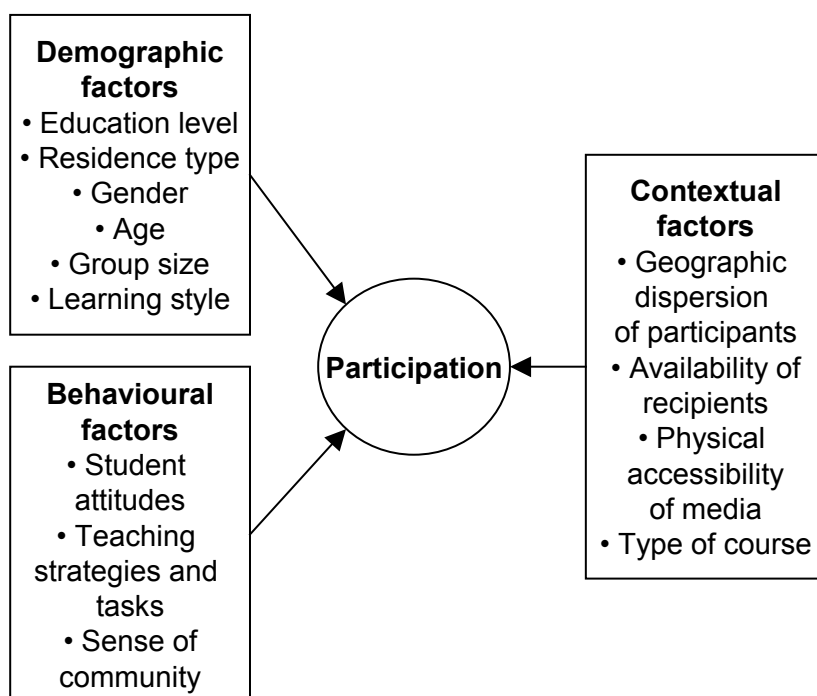

Figure 6.3. A model of online student participation and influencing factors

6.5.1 Demographic factors

McLean and Morrison (2000) investigated the influence of six sociodemographic variables on participation: gender, age, education level, occupation, residence in urban or rural areas, and region of residence. Of these, *education level* and *residence type* were significantly related with participation: “Learners with university degrees participated more than did learners without degrees, and learners residing in cities participated more than did learners residing in rural areas” (p. 33). The study of McLean and Morrison has two weaknesses: It only includes thirty respondents and it used a simplistic measure of participation, i.e. the number of written messages. From the studies of this thesis it seems likely that education level may influence participation. The undergraduate course on business English was characterized by fewer discussions than the master courses on knowledge management. One of several possible explanations for this includes the maturity of students.

Gender does not seem to be a good predictor of online student participation. As written above, McLean and Morrison (2000) did not identify a significant correlation between gender and participation. Arbaugh (2000) found that women wrote a higher number of messages but only identified a moderately significant difference between the genders. On the other hand, Ross (1998) found that men wrote a higher number of “productive contributions”. In sum, these studies suggest that there is no obvious relationship between gender and online student participation.

Age and the relationship with participation was investigated in a study that was not included in the thesis (Keller & Hrastinski 2006). Age was found to significantly affect perceived participation, as older students were related with lower means for perceived participation, particularly in synchronous discussions. However, McLean and Morrison (2000) did not identify a significant correlation between gender and participation. Thus, the relationship between age and online student participation seems to be complex.

Group size was investigated in Paper V, where two online classes of different sizes ($n=8, 19$) were compared. It was found that the synchronous discussions especially were related with a higher level of

participation in the smaller class. This finding is supported by Palloff and Pratt (1999) who recommend that an ideal group size when communicating synchronously is less than ten students. Including a high number of students in synchronous discussions can lead to confusion since it may become unmanageable to know who is answering what to whom (Contreras-Castillo et al. 2006) and, logically, this issue is of more concern in larger groups.

Learning styles were also investigated in the study mentioned above (Keller & Hrastinski 2006). We identified few significant correlations between learning styles and perceptions of online discussions. Pragmatists, defined as learners who seek out new ideas and take every opportunity to experiment with applications (Honey & Mumford 1985), felt to a higher degree comfortable to communicate synchronously, than students of other learning styles. A limitation of the study was that it only included a class with 19 students, which is a rather small population for statistical analyses. In a book chapter, we further explored the relationship between learning styles and online education through a literature review (Keller & Hrastinski 2007). The findings of the reviewed studies were inconclusive, which led us to conclude that there is no clear relationship between learning styles and performance in online education and online discussions.

6.5.2 Behavioural factors

Student attitudes toward online participation have, not surprisingly, been found to affect participation. In Paper III and IV, IM adopters were compared with non-adopters. It is likely that certain types of students, who were more interested in interacting socially, chose to use the IM system in the first place. However, some students of different opinion did not adopt IM during the course:

I didn't have a need to socialize with others in this course. I felt that I wanted to complete the credits and I wanted to do it by myself. I wasn't interested in group work. (Interview A2, Paper IV)

In the studies of Paper III and IV, it was also found that a student who had used IM for 4.5 years to communicate with friends did not adopt IM to support course work, since she preferred to use IM for

communicating with friends. Thus, it should not necessarily be assumed that IM users would adopt the medium in online courses.

Teaching strategies and *the tasks* of a course are commonly argued to play a key role in online education, which includes stimulating participation. For example, in the BEO course, the use of IM was voluntary and the teacher used the medium to a limited extent. In the KM courses, the teacher participated and made student participation in the online discussions mandatory. This led to students on the BEO course mainly communicating synchronously to support group work while students on the KM courses communicated synchronously to support class-wide discussions. Thus, in the KM courses, the students communicated with more peers than in the BEO course. Consequently, there should be no doubt that the teacher shapes synchronous communication.

The teacher is essential in motivating, supporting, and enhancing student interest and learning (Moore 1989). For example, Dennen (2005) identified the following teaching strategies that enhanced online student participation: build in clear reasons or goals, allow students to take different perspectives or share their own point of views, participate moderately and provide regular feedback. Variables related with teaching strategies include participation by instructors (e.g., Mazzolini & Maddison 2003), instructor style (e.g., Webster & Hackley 1997), moderation techniques (e.g., Veerman, Andriessen & Kanselaar 2000) and assessment of contributions (e.g., Macdonald 2003). Other factors include how teachers formulate tasks, the requirements of the tasks, the topics of the tasks and students' attitude towards the significance of the tasks (Fåhræus & Döös 2006). It has also been argued that teachers play an important role in supporting students in the move to increased use of technology in their learning (Jelfs & Colbourn 2002).

The concept of *sense of community* might help explain why the BEO 03 class, where IM was not used, was related with a higher level of participation than the BEO 04 class, where IM was used. If there was a strong sense of community in project groups this might have affected participation on the class level negatively. This hypothesis is supported by Wenger's (1998) theory of barriers between communities and Putnam's (2000) statement that "strong in-group loyalty" may create "strong out-group antagonism" (p. 23). The sociogram of Figure 4.2

suggests that IM may have contributed to a polarization of the students.

6.5.3 Contextual factors

As described in the third chapter, naturally occurring groups have been investigated in the empirical studies. According to Robson (2002), this may be subject to internal validity since contextual factors are likely to have affected the results. Massey and Montoya-Weiss (2006) explored how media selection and use may be affected by contextual factors from a knowledge management perspective. They put forward three critical contextual factors that may affect perceived media utility. In Table 6.3, these factors are listed and exemplified.

Table 6.3. Three critical contextual factors that may affect perceived media utility (adapted from Massey & Montoya-Weiss 2006)

Factor	Example of implication	Paper III-IV	Paper V
Geographic dispersion of participants	Geographically co-located students may be more likely to prefer meeting face-to-face.	Social network surveys revealed that the students seldom met face-to-face.	Interviews revealed that most project teams chose to meet face-to-face only once or twice.
Availability of recipients	If recipients are not perceived to be available by a medium, an other medium might be preferred.	Interviews revealed that some students chose not to use IM because other students were not available.	This was not an issue since participation in the discussions was mandatory.
Physical accessibility of media	If a CMC medium is related with technical difficulties it is less likely that the student will adopt the medium.	Interviews revealed that some students and one project group chose not to use IM because of technical difficulties.	Electronic logs and interviews revealed that there were technical problems, especially when using the chat.

Massey and Montoya-Weiss (2006) propose that co-located participants may not perceive communication media as useful since face-to-face

meetings are preferred. However, this was not the case in the empirical studies, which may, at least partly, be explained by the *geographic dispersion of participants*. *Availability of recipients* seemed to be an issue of Paper III and IV and *physical accessibility of media* seemed to be an issue of Paper III-V. Key reasons for not adopting IM in the studies of Paper III and IV, were that students felt that peers were not available or that the medium was not perceived as accessible because of technical problems. Availability of recipients was not an issue in the study of Paper V since participation was mandatory. In the empirical studies, some students reported technical difficulties when using IM and chat, which might have affected participation negatively. In a related study, technical problems were identified as a key problem with using chat but not when using the discussion board (Keller & Hrastinski 2006).

Surprisingly, few have examined the relationship between *type of course* (e.g., subject) and online student participation. However, it is generally recommended that online courses should be designed differently depending on the type of course (Moore & Kearsley 1996). From the studies of this thesis it seems likely that the type of course may influence participation. The undergraduate course on business English was characterized by fewer discussions than the master courses on knowledge management. As mentioned earlier, one possible explanation is the maturity of students but another one is the focus on sharing personal experiences in the latter courses.

6.5.4 Tentative implications on micro and macro levels

By drawing on the discussion above, the results and review of research indicated that at least some of the influencing factors reviewed affected online student participation. Layder's (1993) research map has been used to provide tentative implications of these influencing factors. He argues that one's research can beneficially be analysed on levels ranging from micro levels towards macro levels. In Table 6.4, it is distinguished between implications for micro levels, e.g., individual courses, and for macro levels, e.g., implications for the management of online education.

Table 6.4. Examples of implications of influencing factors for online student participation on micro and macro levels

Factor	Implication on micro level	Implication on macro level
Education level	Varying degrees of online participation may be expected in groups including both undergraduate and graduate students.	A higher level of online participation may be expected in graduate courses.
Group size	It may be beneficial to divide large groups into smaller ones to encourage online participation, especially when communicating synchronously.	A higher level of online participation may be expected in courses of fewer students, especially when communicating synchronously.
Student attitudes	Varying degrees of online participation may be expected among students because of varying attitudes.	A higher level of online participation may be expected in courses where students have positive attitudes towards CMC media.
Teaching strategies and tasks	Teaching strategies and tasks are key in enhancing online student participation.	Strategies for encouraging online student participation need to be developed.
Geographic dispersion of students	Varying degrees of online participation may be expected among students depending on geographic dispersion.	A higher level of online participation may be expected when students are geographically dispersed.
Availability of students	Varying degrees of online participation may be expected among students depending on whether they are co-located in learning environments.	A higher level of online participation may be expected if the learning environment supports presence awareness (e.g., list of peers currently online).
Physical accessibility of media	Varying degrees of online participation may be expected among students because some experience technical difficulties.	A higher level of online participation may be expected if few technical problems occur.
Type of course	Varying degrees of online participation may be expected in different parts of a course.	Varying degrees of online participation may be expected in different types of online courses.

6.6 Quality of research design

In the empirical studies, the focus has been on student participation. Thus, a weakness is that the effect on other important variables such as learning outcomes, student satisfaction and retention rates, were not studied. However, previous research that was reviewed in section 2.4.2 suggests that student participation affect these variables positively. Participation is indeed a complex phenomenon and, in retrospect, it seems that it was a wise decision to keep the thesis focused on this variable. This made it possible to gain a deeper understanding of participation rather than a shallow understanding of several variables and also contribute methodologically on how participation might be studied.

Online student participation was mainly studied from a student perspective. A consequence of not studying the actions of teachers as thoroughly, is that the thesis cannot give detailed guidance on how to design learning activities. This is an opportunity for further research, especially for researchers in the field of educational science. In Paper III and IV, reasons for choosing a student perspective were put forward. First, it was intended to compare IM with all types of communication, including telephone and face-to-face conversations. It was not possible to observe all communications. Second, it was the student's interpretation of whether communication included a particular type of exchange (e.g., social support) that was considered most important and not the researcher's interpretation (Haythornthwaite 2001). In Paper III, it was intended to log IM communication to be able to exemplify student use and opinions of the IM system. This attempt failed because of technical difficulties. IM logs were automatically maintained by the IM system, which unfortunately seemed to delete old logs automatically.

According to Picciano (2002), perceived and actual communication have been reported to differ when studying CMC in educational settings. It was decided to complement the student perspective with analyses of actual communication in Paper V. This could be achieved since communication in the online discussions was electronically logged. Thus, as suggested in the third chapter, more powerful

conclusions such as the following one could be drawn when data was triangulated:

The students of both classes reported stronger overall network densities in the synchronous setting, especially in the smaller class. This finding underlines the fact that students not only produced more text in the synchronous discussions, but that they also felt they maintained more ties with peers. This was also evident in the interviews where eight students said they maintained ties with more students in the synchronous settings. Three interviewees did not feel there was a difference between the two media while one felt that he maintained ties with more students in the asynchronous setting. (Paper V, p. 12).

6.6.1 Quality of empirical research

There are a number of criteria that can be used when evaluating the quality of social science research, including reliability, construct validity, internal validity and generalizability or external validity (Robson 2002; Yin 2003). The terms reliability and validity are avoided by some proponents of qualitative research designs (e.g., Lincoln & Guba 1985) while others argue that “good rigorous research must be reliable and valid” (e.g., Morse 1999, p. 717). I will not take sides in this debate but have chosen to use the traditional terms of reliability and validity as a framework for discussing the quality of the empirical research. One argument for this approach is that “attempts to rename and disclaim the traditional terms [reliability and validity] ... provide support for the view that qualitative studies are unreliable and invalid” (Robson 2002, p. 170).

Reliability is central when assessing the quality of research – unless a measure is reliable the results cannot be valid (Robson 2002). Traditionally, it is argued that the findings and conclusions of other researchers should be identical if using the same measure. However, this has been questioned, especially in qualitative research (Merriam 1994). Problems of reliability might include participant error and bias, and observer error and bias (Robson 2002). For example, students might answer questions differently depending on when they were asked or might seek to please their teacher. This may be an issue of Paper V, when I was an “involved researcher” (Walsham 2006), i.e. both a teacher and a researcher. However, in the remaining empirical studies, I

was an “outside researcher”, which implies that this problem was not evident. Another issue mentioned by Robson (2002) is that researchers might interpret answers to a question differently depending on when data is analysed or might unconsciously seek to confirm their hypotheses. These problems were addressed by using complementary measures on both perceived and actual participation. When developing measures, previous measures that have been shown to be reliable were adopted (Gunawardena & Zittle 1997; Haythornthwaite 2000, 2001; Rovai et al. 2004; Webster & Hackley 1997).

Construct validity concerns “establishing correct operational measures for the concepts being studied” (Kidder & Judd 1986 in Yin 2003, p. 34). Since “any one way of measuring or gathering data is likely to have its shortcomings” preferably multiple methods should be used (Robson 2002, p. 103). The construct validity of the studies of the thesis was increased by *method triangulation* (combining quantitative and qualitative methods) and *data triangulation* (relying on several sources of evidence) (Patton 1990; Yin 2003). Also, to increase construct validity, methods of data collection were based on Wenger’s (1998) definition of participation and, as mentioned above, drew on previously well-established measures.

When studying Wenger’s (1998) discussion of participation, which underlies this thesis, the following parts may be distinguished: taking part, relations with others, doing, talking (communicating), thinking, feeling and belonging. Retrospectively, a weakness of the empirical studies has been to assess cognitive participation (e.g., thinking). However, in Paper III and IV, students were asked to self-evaluate time spent working with course content. Processes such as reading, doing and thinking are probably related with, and enhanced by, communication with peers. For example, it is probable that students complete tasks before and after group meetings. However, cognitive dimensions could have been studied more thoroughly.

Internal validity is achieved when some “conditions are shown to lead to other conditions” (Yin 2003, p. 34). Thus, a finding that participation increases after a synchronous discussion does not necessarily mean it increased because of the discussion (Robson 2002). As was discussed in section 6.5, other factors are likely to have affected online student participation in the empirical studies. Many intervening variables seem

to have been constant between, for example, the BEO 03 and BEO 04 offerings, but it is simply not possible to control all intervening variables when conducting naturalistic case studies (Robson 2002). In order to address the issue of internal validity, considerable effort has been invested in searching for possible intervening variables, which have been discussed in the papers and section 6.5.

Generalizability or *external validity* refers to knowing whether a finding or theory is valid in a different setting than it was tested and confirmed (Lee & Baskerville 2003; Robson 2002; Yin 2003). Generalizability of case study research can be increased by relying on several cases (Yin 2003), even though Lee and Baskerville (2003) remind us that increasing generalizability is more complex than simply increasing the number of cases. An obvious advantage of the single-case design is that the chosen case can be analysed more thoroughly. Consequently, it was decided to focus on three case settings, which made it possible to study each case thoroughly and also possible to test the results in several settings. This was addressed by defining the level of generality or scope and by using modal qualifiers, to give a deeper insight into which contexts and situations the discerned relationship is likely to hold (Gregor 2006).

As discussed in the papers, some of the results of the empirical studies may be valid in other settings, but, if so, this needs to be confirmed. However, in Paper VI, focus groups were used to test whether the design propositions, which were based on the key findings of the empirical studies, may be valid in different settings than they were developed. Most of the propositions received strong support in focus group sessions with experienced practitioners, which serve as an indication of a sufficient level of external validity. Specific criteria for testing the quality of the design science approach of Paper VI are discussed in the next section.

6.6.2 Quality of design research

Paper VI was conducted from a design science perspective, which has been argued to be guided by other criteria of quality. The most well-known criteria are Hevner et al.'s (2004) guidelines for design science in IS research. However, as argued in section 4.4, Hevner et al. focus on

the IT artefact *per se* while leaving out people and organizations. Thus, in Paper VI, a different set of quality criteria were used.

In Paper VI, we argued that key criteria for the development of design theory are that such theory should be based on *kernel theories*, *empirical studies* and *systematic reviews* of previous research. Moreover, van Aken (2005) has proposed that design theory should be tested on two levels. *Alpha testing* includes further testing and development by the originators of the design theory. *Beta testing* includes further testing and development by other researchers. We also added *gamma testing*, which includes testing whether practitioners can use a design theory and if the use of the theory supports practitioners in achieving desired outcomes. The design propositions of Paper VI were based on kernel theories, cross-case analyses of the empirical studies of the thesis, and systematic reviews of previous research. The propositions were mainly tested and developed through alpha testing but also through gamma testing by obtaining feedback on the design propositions from experienced practitioners in focus group sessions.

6.7 Limitations and further research

In each of the papers, limitations were put forward and suggestions for how these limitations can be addressed in further research were provided. Moreover, the weaknesses of the research design, which were discussed in the previous section, can be addressed in future research. Below, five examples of opportunities for further research are suggested.

6.7.1 Improving by reviewing

In Paper I, it was argued that “review articles are critical to strengthening [...] a field” (Webster & Watson 2002, p. xiv) and that the field of research on educational technology has become mature enough to become its own study object. Hopefully, these initial reviews will spur future attempts in order for the field to be improved by continuously being critically reviewed. It was also suggested that the classification framework from Paper I can be further developed since

the percent figure of inter-rater reliability was 0.74 (Holsti 1969), which indicates that the classification scheme can be improved to achieve a higher degree of clarity.

Paper II gave four examples of how the review might guide future research. First, it was argued that the dominance of empirical studies in research on CMC in education partly support critics that have argued that the focus has been to give “anecdotal advice” rather than building theory (Mazzolini & Maddison 2003; Romiszowski & Mason 2004). Second, it was argued that research needs to focus more on emerging media. Researchers should not only focus on established media, such as discussion boards, but also need to support practitioners by evaluating how emerging media may be beneficially used in online education. Third, the neglect of synchronous communication, despite the increasing popularity of such communication (Kinshuk & Chen 2006), was criticized. Finally, we foresaw that asynchronous and synchronous communication will be combined to an increasing extent in both in traditional and online education settings and that there is a lack of research on this topic.

6.7.2 Theorizing on CMC artefacts

In a research commentary, Orlikowski and Iacono (2001) argued that the IS field has not deeply engaged its core subject matter: the IT artefact. Instead, central significance has been given to the context, capabilities of the IT artefact and dependent variables. For example, Hertz-Lazarowitz and Bar-Natan (2002) studied how three types of learning environments (cooperative learning, CMC and a combination of these) affected dependent variables (students’ perceptions, teachers’ assessment and evaluation of project work). They found that the combination of cooperative learning and CMC influenced the dependent variables positively. However, it is unclear what type of CMC that was studied. This may be argued as problematic since the characteristics of different media may be very different. An example of theorizing on the IT artefact is Kear (2001) who used two versions of a system (FirstClass 3.5 and 5.5) in order to study the effect of displaying messages of a discussion board in chronological order vs. grouping them by subject in “threads”. She found that “the way threads are represented in a conferencing system can have a significant effect on

how students use the system, and on the character of the resulting discussion” (p. 81).

In the empirical studies of this thesis, different means of communication have been compared. The focus of the empirical studies has been on discussion board, IM and chat. The characteristics of these types of systems have been described. However, in-depth analyses of how characteristics of these systems affected participation have not been conducted. For example, the IM system that was used (MSN Messenger) has features for sending files and using emoticons (e.g., ☺), which might have influenced participation. On a more general level, however, it was found that a characteristic of the IM system, that it lists peers who are online, enabled spontaneous collaboration on project work. It was also found that technical difficulties partly explained why some students preferred communicating asynchronously. Factoring the above, there seem to be opportunities for more in-depth theorization on CMC artefacts.

6.7.3 Measuring online participation

One of the assumptions of this thesis is that participation is a complex phenomenon. Therefore, simple measures, such as message counts, are not enough in labelling some students as active and others as passive participants. The approaches for evaluating participation presented in this thesis were: social network analysis, measures on perceived participation, time spent communicating with peers, time spent working with content, a diary approach, content analysis, interviews and focus groups. However, these initial attempts can be further developed by, for example, refining the data collection approaches and adding new ones. Specifically, the retrospective discussion of the quality of the research design revealed a focus on interpersonal dimensions of participation (personal participation), which underlines the need for further development of measures of cognitive participation.

6.7.4 Participation over time

A number of theories, including adaptive structuration theory (DeSanctis & Poole 1994) and channel expansion theory (Carlson & Zmud 1999), suggest that “experiences with media affect perceptions of media utility” (Massey & Montoya-Weiss 2006, p. 105). This indicates that participation might change over time. For example, students who have had positive experiences of using a medium might use it even more in the future or vice versa. In Paper VI, a measure of perceived participation was compared at two different points in time. Interestingly, the means for most items were higher for synchronous communication when students were asked directly after the discussions but not when they were asked retrospectively. Perceived participation decreased to a larger extent for synchronous discussions than for asynchronous discussions.

The argument that perceived participation in synchronous communication may fade considerably with time is supported by the media synchronicity theory, which predicts that asynchronous communication may become more common as online professional teams mature (DeLuca & Valacich 2006). Thus, if this theory is generalizable to online education, it can be hypothesized that synchronous communication is especially useful in the early stages of online courses or group work in order to develop convergence on shared meaning. Consequently, there is a need for further research that analyses how and why participation changes over time for different types of communication.

6.7.5 Participation by emerging media

Palloff and Pratt (2001) have argued that the advances of online learning environments that some have waited for has not occurred. Like most current research, the empirical studies of Paper III-V focused on text-based media. An exception is Paper VI, where experienced educators participated in focus groups and shared their experiences of different types of synchronous communication. Brown (2000) argues that the past century’s concept of literacy has been very much focused on text but that emerging technologies may better support different intelligences that prefer to communicate, for example,

visually. The increasing use of social software, such as MySpace and YouTube, where the users create and share content, has led to some advocating for the use of such software in online education (Alexander 2006; Duffy 2007).

The media under investigation of this thesis have been part of the transformation of distance education from a focus on the individual towards social perspectives. In parallel, a movement towards Web 2.0, which emphasises the increasing use of social software, can be recognized (O'Reilly 2005). These movements will surely lead to new ways of collaborating and learning in emerging “spaces of interaction” that will be increasingly used in online education and organizations in the future (Dhar & Sundararajan 2007). Initial research efforts include recent discussions of possible benefits of emerging media, such as blogs, wikis and video sharing, and studies on synchronous software that supports audio and video (e.g., Duffy 2007; Schullo et al. 2005). Future research is encouraged to critically study the benefits and limitations of emerging types of communication in order to guide practitioners in the complex task of choosing and using media.

6.8 Conclusion

In preparation for the empirical studies, two major literature reviews were conducted (see chapter 3). These are important contributions since the frameworks may be used for describing and analysing research on online education and adjacent research fields in the future. The reviews will hopefully contribute towards improving research by providing researchers with an overview of current research approaches and topics.

This thesis gives a thorough understanding of how, why, and when synchronous communication, as a complement to asynchronous communication, may affect participation in online education. In particular, light was shed on two dimensions of online student participation, which were labelled personal participation and cognitive participation. The thesis suggests that synchronous communication may be used to better support personal participation. This is likely to induce arousal and motivation, and increased convergence on meaning,

especially in smaller groups. Synchronous communication seems particularly useful for supporting task and social support relations, and to exchange information with a lower degree of complexity. The questions of this thesis will, however, need to be continuously asked since the complex practice of online education, including applications and developments of various media, are continuously evolving.

References

- Adam, S. (2006). An introduction to learning outcomes. In E. Froment, J. Kohler, L. Purser & L. Wilson (Eds.), *EUA Bologna handbook: Making Bologna work* (pp. B2.3-1). Berlin: Raabe.
- Alavi, M. (1994). Computer-mediated collaborative learning: An empirical evaluation. *MIS Quarterly*, 18(2), 159-174.
- Alavi, M., & Dufner, D. (2005). Technology-mediated collaborative learning: A research perspective. In S. R. Hiltz & R. Goldman (Eds.), *Learning together online: Research on asynchronous learning networks* (pp. 191-213). Mahwah, New Jersey: Lawrence Erlbaum.
- Alavi, M., & Leidner, D. E. (2001a). Knowledge management and knowledge management systems: Conceptual foundations and research issues. *MIS Quarterly*, 25(1), 107-136.
- Alavi, M., & Leidner, D. E. (2001b). Research commentary: Technology-mediated learning - a call for greater depth and breadth of research. *Information Systems Research*, 12(1), 1-10.
- Alavi, M., Marakas, G. M., & Youngjin, Y. (2002). A comparative study of distributed learning environments on learning outcomes. *Information Systems Research*, 13(4), 404-415.
- Alexander, B. (2006). Web 2.0: A new wave of innovation for teaching and learning? *Educause Review*, 41(2), 33-44.
- Anderson, T., & Garrison, D. R. (1998). Learning in a networked world: New roles and responsibilities. In C. Gibson (Ed.), *Distance learners in higher education* (pp. 97-112). Madison, WI: Atwood Publishing.
- Arbaugh, J. B. (2000). An exploratory study of the effects of gender on student learning and class participation in an Internet-based MBA course. *Management Learning*, 31(4), 503-519.
- Astin, A. W. (1996). Involvement in learning revisited: Lessons we have learned. *Journal of College Student Development*, 37(2), 123-134.
- Astin, A. W. (1999). Student involvement: A developmental theory for higher education. *Journal of College Student Development*, 40(5), 518-529.
- Avgerou, C. (2000). Information systems: What sort of science is it? *Omega*, 28(5), 567-579.

- Baskerville, R. L., & Myers, M. D. (2002). Information systems as a reference discipline. *MIS Quarterly*, 26(1), 1-14.
- Baskerville, R. L., Pries-Heje, J., & Venable, J. (2007). *Soft design science research: Extending the boundaries of evaluation in design science research*. Proceedings of the Second International Conference on Design Science Research in Information Systems and Technology, Pasadena, CA.
- Benbasat, I., Goldstein, D. K., & Mead, M. (1987). The case research strategy in studies of information systems. *MIS Quarterly*, 11(3), 369-386.
- Bender, T. (2003). *Discussion-based online teaching to enhance student learning: Theory, practice and assessment*. Sterling, Virginia: Stylus.
- Bento, R., & Schuster, C. (2003). Participation: The online challenge. In A. Aggarwal (Ed.), *Web-based education: Learning from experience* (pp. 156-164). Hershey, Pennsylvania: Idea Group Publishing.
- Beynon-Davies, P., Owens, I., & Williams, M. D. (2004). Information systems evaluation and the information systems development process. *The Journal of Enterprise Information Management*, 17(4), 276-282.
- Bhaskar, R. (1978). *A realist theory of science*. Harvester: Hemel Hempstead.
- Björck, U. (2004). *Distributed problem-based learning: Studies of a pedagogical model in practice*. Doctoral thesis, Göteborg University, Göteborg.
- Bloom, B. S. (1956). *Taxonomy of educational objectives: Handbook 1, cognitive domain*. New York: Longman.
- Boneva, B., Quinn, A., Kraut, R., Kiesler, S., Cummings, J., & Shklovski, I. (2006). Teenage communication in the instant messaging era. In R. Kraut, M. Brynin & S. Kiesler (Eds.), *Domesticating information technology*. Oxford: Oxford University Press.
- Bonk, C., & King, K. (1995). *Computer conferencing and collaborative writing tools: Starting a dialogue about student dialogue*. Proceedings of the First International Conference on Computer Support for Collaborative Learning, Mahwah, NJ.
- Bonk, C. J., & Cunningham, D. J. (1998). Searching for learner-centered, constructivist, and sociocultural components of collaborative educational learning tools. In C. J. Bonk & K. S. King (Eds.), *Electronic collaborators: Learner-centered technologies for literacy, apprenticeship, and discourse* (pp. 25-30). Mahwah, NJ: Lawrence Erlbaum Associates.
- Bowden, J., & Marton, F. (1998). *The university of learning: Beyond quality and competence in higher education*. London: Kogan Page.
- Brown, A. L., & Palincsar, A. S. (1989). Guided, cooperative and individual knowledge acquisition. In L. B. Resnick (Ed.), *Knowing, learning, and instruction: Essays in honor of Robert Glaser*. Hillsdale, New Jersey: Lawrence Erlbaum Associates.

- Brown, J. S. (2000). Growing up digital: How the web changes work, education, and the ways people learn. *Change*, 32(2), 11-20.
- Brown, J. S., & Duguid, P. (1996). Universities in the digital age. *Change*, 28(4), 10-19.
- Bullen, M. (1998). Participation and critical thinking in online university distance education. *Journal of Distance Education*, 13(2), 1-32.
- Böhlke, O. (2003). A comparison of students participation levels by group size and language stages during chatroom and face-to-face discussions in German. *CALICO Journal*, 21(1), 67-87.
- Cameron, A. F., & Webster, J. (2005). Unintended consequences of emerging communication technologies: Instant messaging in the workplace. *Computers in Human Behavior*, 21(1), 85-103.
- Carlén, U., & Jobring, O. (2005). The rationale of online learning communities. *International Journal of Web Based Communities*, 1(3), 272-295.
- Carlson, J. R., & Zmud, R. W. (1999). Channel expansion theory and the experiential nature of media richness perceptions. *Academy of Management Journal*, 42(4), 153-170.
- Carlsson, S. A. (2006). *Towards an information systems design research framework: A critical realist perspective*. Proceedings of the First International Conference on Design Science Research in Information Systems and Technology, Claremont, CA.
- Carr, S. (2000). As distance education comes of age, the challenge is keeping the students. *Chronicle of Higher Education*, 46(23), A39-A41.
- Carr, T., Cox, G., Eden, A., & Hanslo, M. (2004). From peripheral to full participation in a blended trade bargaining simulation. *British Journal of Educational Technology*, 35(2), 197-211.
- Cavaye, A. L. M. (1996). Case study research: A multi-faceted research approach for IS. *Information Systems Journal*, 6(3), 227-242.
- Chen, K., Yen, D. C., & Huang, A. H. (2004). Media selection to meet communication contexts: Comparing e-mail and instant messaging in an undergraduate population. *Communications of the Association for Information Systems*, 14, 387-405.
- Chen, W., & Hirschheim, R. (2004). A paradigmatic and methodological examination of information systems research from 1991 to 2001. *Information Systems Journal*, 14(3), 197-235.
- Cobb, P. (1994). Where is the mind? Constructivist and sociocultural perspectives on mathematical development. *Educational Researcher*, 23(7), 13-20.

- Contreras-Castillo, J., Favela, J., Perez-Fragoso, C., & Santamaria-del-Angel, E. (2004). Informal interactions and their implications for online courses. *Computers & Education, 42*(2), 149-168.
- Contreras-Castillo, J., Perez-Fragoso, C., & Favela, J. (2006). Assessing the use of instant messaging in online learning environments. *Interactive Learning Environments, 14*(3), 205-218.
- Corno, K., & Mandinach, E. B. (1983). The role of cognitive engagement in classroom learning and motivation. *Educational Psychologist, 18*(2), 88-108.
- Daft, R. L., & Lengel, R. H. (1986). Organizational information requirements, media richness and structural design. *Management Science, 32*(5), 554-571.
- Dahlén, S., & Hudner, T. (2002). *Det virtuella seminariet: En plattform för lärande i distansutbildning?* The Department of Teacher Education, Uppsala University.
- Dahlgren, M. A., Larsson, S., & Walters, S. (2006). Making the invisible visible. On participation and communication in a global, web-based master's programme. *Higher Education, 52*(1), 69-93.
- Daugherty, M., & Turner, J. (2003). Sociometry: An approach for assessing group dynamics in web-based courses. *Interactive Learning Environments, 11*(3), 263-275.
- Davidson-Shivers, G. V., Muilenburg, L. Y., & Tanner, E. J. (2001). How do students participate in synchronous and asynchronous online discussions? *Journal of Educational Computing Research, 25*(4), 351-366.
- Davies, D. (1989). Computer-supported cooperative learning: Interactive group technologies and distance learning systems. In R. Mason & A. A. Kaye (Eds.), *Mindweave: Communication, computers and distance education* (pp. 228-231). Oxford: Pergamon.
- Davies, J., & Graff, M. (2005). Performance in e-learning: Online participation and student grades. *British Journal of Educational Technology, 36*(4), 657-663.
- Dawson, S. (2006). A study of the relationship between student communication interaction and sense of community. *Internet and Higher Education, 9*(3), 153-162.
- DeLuca, D., & Valacich, J. S. (2006). Virtual teams in and out of synchronicity. *Information Technology & People, 19*(4), 323-344.
- Dennen, V. P. (2005). From message posting to learning dialogues: Factors affecting learner participation in asynchronous discussion. *Distance Education, 26*(1), 127-148.
- DeSanctis, G., & Poole, M. S. (1994). Capturing the complexity in advanced technology use: Adaptive stucturation theory. *Organization Science, 5*(2), 121-147.

- Dhar, V., & Sundararajan, A. (2007). Information technologies in business: A blueprint for education and research. *Information Systems Research*, 18(2), 125-141.
- Dillenbourg, P. (1999). Introduction: What do you mean by "collaborative learning"? In P. Dillenbourg (Ed.), *Collaborative learning: Cognitive and computational approaches* (pp. 1-19). Oxford: Elsevier Science.
- Duffy, P. (2007). *Engaging the YouTube Google-eyed generation: Strategies for using Web 2.0 in teaching and learning*. Proceedings of the 6th European Conference on e-Learning, Copenhagen.
- Duffy, T. M., & Jonassen, D. H. (1992). Constructivism: New implications for instructional technology. In T. M. Duffy & D. H. Jonassen (Eds.), *Constructivism and the technology of instruction: A conversation*. New Jersey: Lawrence Erlbaum.
- Dziuban, C., & Moskal, P. (2001). *Emerging research issues in distributed learning*. Proceedings of the 7th Sloan-C International Conference on Asynchronous Learning Networks, Orlando, FL.
- Edelson, D. C., Pea, R. D., & Gomez, L. (1996). Constructivism in the collaboratory. In B. G. Wilson (Ed.), *Constructivist learning environments: Case studies in instructional design* (pp. 151-164). Englewood Cliffs, New Jersey: Educational Technology Publications.
- Eisenhardt, K. M. (1989). Building theories from case study research. *Academy of Management Review*, 14(4), 532-550.
- Eisenstadt, M., Komzak, J., & Dzbor, M. (2003). *Instant messaging + maps = powerful collaboration tools for distance learning*. Proceedings of the TelEduc 2003 Conference, Havana.
- Ellis, A. (2003). Personality type and participation in networked learning environments. *Educational Media International*, 40(1-2), 101-114.
- Ewing, J. (2000). Enhancement of online and offline student learning. *Educational Media International*, 37(4), 205-217.
- Fawcett, J., & Downs, F. S. (1986). *The relationship of theory and research*. Norwalk: Appleton Century Crofts.
- Fidas, C., Kapsalis, V., Tranoris, C., & Avouris, N. (2006). Synchronous support and monitoring in web-based educational systems. *Campus-Wide Information Systems*, 23(3), 138-148.
- Flanagin, A. J. (2005). IM online: Instant messaging use among college students. *Communication Research Reports*, 22(3), 175-187.
- Forsberg, H. O. (2007). *Resultat av Nätuniversitetet 2003-2006*. Retrieved Aug 28, 2007, from: <http://www.nshu.se/download/6220/070514resultatnatuniv0206hofaf.pdf>.

- Fredericksen, E., Picket, A., Shea, P., Pelz, W., & Swan, K. (2000). Student satisfaction and perceived learning with on-line courses: Principles and examples from the SUNY learning network. *Journal of Asynchronous Learning Networks*, 4(2), 7-41.
- Fåhræus, E. R. (2003). *A triple helix of learning processes: How to cultivate learning, communication and collaboration among distance-education students*. Doctoral thesis, Stockholm University/The Royal Institute of Technology, Stockholm.
- Fåhræus, E. R., & Döös, M. (2006). *Kompetent nätdialog: Tankar länkade i digitala samtal*. Retrieved Feb 26, 2007, from: http://www.cfl.se/natochbildning/html/nr_2_06/kompetent_natdialog.htm.
- Garrison, D. R. (1985). Three generations of technological innovation in distance education. *Distance Education*, 6(2), 235-241.
- Garrison, D. R., & Anderson, T. (2003). *E-learning in the 21st century: A framework for research and practice*. London: RoutledgeFalmer.
- Garrison, D. R., & Shale, D. (1987). Mapping the boundaries of distance education: Problems in defining the field. *The American Journal of Distance Education*, 1(1), 7-13.
- Garrison, R. (2000). Theoretical challenges for distance education in the 21st century: A shift from structural to transactional issues. *International Review of Open and Distance Learning*, 1(1), 1-17.
- Garton, L., Haythornthwaite, C., & Wellman, B. (1999). Studying on-line social networks. In S. Jones (Ed.), *Doing Internet research: Critical issues and methods for examining the Net* (pp. 77-105). Thousand Oaks: Sage Publications.
- Graham, C. R. (2006). Blended learning systems: Definition, current trends and future directions. In C. J. Bonk & C. R. Graham (Eds.), *The handbook of blended learning: Global perspectives, local designs* (pp. 3-21). San Francisco, CA: Pfeiffer.
- Greenberg, S. (1991). *Computer-supported co-operative work and groupware*. London: Academic Press.
- Gregor, S. (2006). The nature of theory in information systems. *MIS Quarterly*, 30(3), 611-642.
- Gregor, S., & Jones, D. (2007). The anatomy of a design theory. *Journal of the Association for Information Systems*, 8(5), 312-335.
- Grint, K. (1989). Accounting for failure: Participation and non-participation in CMC. In R. Mason & A. A. Kaye (Eds.), *Mindweave: Communication, computers and distance education* (pp. 189-192). Oxford: Pergamon.
- Gunawardena, C. N., & McIsaac, M. S. (2004). Distance education. In D. H. Jonassen (Ed.), *Handbook of research on educational communications and technology* (pp. 355-395). Mahwah, New Jersey: Lawrence Erlbaum Associates.

- Gunawardena, C. N., & Zittle, F. J. (1997). Social presence as a predictor of satisfaction within a computer-mediated conferencing environment. *The American Journal of Distance Education, 11*(3), 8-16.
- Hakkarainen, K., & Palonen, T. (2003). Patterns of female and male students' participation in peer interaction in computer-supported learning. *Computers & Education, 40*(4), 327-342.
- Hammond, M. (2000). Communication within on-line forums: The opportunities, the constraints and the value of a communicative approach. *Computers & Education, 35*(4), 251-262.
- Hansen, M. T. (2002). Knowledge networks: Explaining effective knowledge sharing in multiunit companies. *Organization Science, 13*(3), 232-248.
- Hansen, T., Dirckinck-Holmfeld, L., Lewis, R., & Rugel, J. (1999). Using telematics for collaborative knowledge construction. In P. Dillenbourg (Ed.), *Collaborative learning: Cognitive and computational approaches* (pp. 169-198). Oxford: Elsevier Science Ltd.
- Harasim, L. (1989). On-line education: A new domain. In R. Mason & A. A. Kaye (Eds.), *Mindweave: Communication, computers and distance education* (pp. 50-62). Oxford: Pergamon.
- Harasim, L. (2000). Shift happens: Online education as a new paradigm in learning. *Internet and Higher Education, 3*(1-2), 41-61.
- Haythornthwaite, C. (1996). Social network analysis: An approach and set of techniques for the study of information exchange. *Library and Information Science Research, 18*(4), 323-342.
- Haythornthwaite, C. (2000). Online personal networks: Size, composition and media use among distance learners. *New Media & Society, 2*(2), 195-225.
- Haythornthwaite, C. (2001). Exploring multiplexity: Social network structures in a computer-supported distance learning class. *The Information Society, 17*(3), 211-226.
- Haythornthwaite, C. (2002). Building social networks via computer networks: Creating and sustaining distributed learning communities. In K. A. Renninger & W. Schumar (Eds.), *Building virtual communities: Learning and change in cyberspace* (pp. 159-190). Cambridge: Cambridge University Press.
- Haythornthwaite, C., & Kazmer, M. M. (2002). Bringing the Internet home: Adult distance learners and their Internet, home, and work worlds. In B. Wellman & C. Haythornthwaite (Eds.), *The Internet in everyday life* (pp. 431-463). Malden, Massachusetts: Blackwell Publishing.
- Haythornthwaite, C., & Kazmer, M. M. (Eds.). (2004). *Learning, culture and community in online education: Research and practice*. New York: Peter Lang Publishers.

- Hedberg, J., & Corrent-Agostinho, S. (2000). Creating a postgraduate virtual community: Assessment drives learning. *Educational Media International*, 37(2), 83-90.
- Hertzberg, S., & Rudner, L. (1999). The quality of researchers' searches of the ERIC database. *Education Policy Analysis Archives*, 7(25).
- Hertz-Lazarowitz, R. H., & Bar-Natan, I. (2002). Writing development of Arab and Jewish students using cooperative learning (CL) and computer-mediated communication (CMC). *Computers & Education*, 39(1), 19-36.
- Hew, K. F., Kale, U., & Kim, N. (2007). Past research in instructional technology: Results of a content analysis of empirical studies published in three prominent instructional technology journals from the year 2000 through 2004. *Journal of Educational Computing Research*, 36(3), 269-300.
- Hevner, A. R., March, S. T., Park, J., & Ram, S. (2004). Design science in information systems research. *MIS Quarterly*, 28(1), 75-105.
- Hiltz, S. R., Coppola, N., Rotter, N., Turoff, M., & Benbunan-Fich, R. (2000). Measuring the importance of collaborative learning for the effectiveness of ALN: A multi-measure, multi-method approach. *Journal of Asynchronous Learning Networks*, 4(2), 103-125.
- Hiltz, S. R., & Goldman, R. (2005). What are asynchronous learning networks? In S. R. Hiltz & R. Goldman (Eds.), *Learning together online: Research on asynchronous learning networks* (pp. 3-18). Mahwah, New Jersey: Lawrence Erlbaum.
- Hiltz, S. R., & Turoff, M. (1978). *The network nation: Human communication via computer*. Reading, MA: Addison-Wesley.
- Hiltz, S. R., & Turoff, M. (2002). What makes learning networks effective? *Communications of the ACM*, 45(4), 56-59.
- Hiltz, S. R., & Wellman, B. (1997). Asynchronous learning networks as a virtual classroom. *Communications of the ACM*, 40(9), 44-49.
- Hirschheim, R., & Klein, H. K. (2003). Crisis in the IS field? A critical reflection on the state of the discipline. *Journal of the Association for Information Systems*, 4(5), 237-293.
- Hislop, D. (2006). *Taking account of structure: Re-evaluating practice based perspectives on knowledge via critical realism*. Proceedings of the International Conference on Organizational Learning, Knowledge and Capabilities, Warwick, UK.
- Hoadley, C., & Pea, R. D. (2002). Finding the ties that bind: Tools in support of a knowledge-building community. In K. A. Renninger & W. Schumar (Eds.), *Building virtual communities: Learning and change in cyberspace* (pp. 321-354). Cambridge: Cambridge University Press.
- Holmberg, B. (1989). *Theory and practice of distance education*. London: Routledge.

- Holsti, O. (1969). *Content analysis for the social sciences and humanities*. Don Mills: Addison-Wesley.
- Honey, P., & Mumford, A. (1985). *Lärstilshandboken*. Lund: Studentlitteratur.
- Hrastinski, S. (2006a). The relationship between adopting a synchronous medium and participation in online group work: An explorative study. *Interactive Learning Environments*, 14(2), 137-152.
- Hrastinski, S. (2006b). Synkron kommunikation i en distanskurs (synchronous communication in a distance learning course). In O. Jobring, U. Carlén & J. Bergenholtz (Eds.), *Att skapa lärgemenskaper och mötesplatser på nätet* (pp. 215-230). Lund: Studentlitteratur.
- Hrastinski, S. (2007a). Dimensions of synchronous online education. In N. Buzzetto-More (Ed.), *Principles of effective online teaching: A handbook for experienced teachers developing eLearning* (pp. 105-119). Santa Rosa, California: Informing Science.
- Hrastinski, S. (2007b). Using chat as a complement to discussion board in small-group online seminars: How is student participation affected? *International Journal of Knowledge and Learning*, 3(5-6).
- Hrastinski, S., & Keller, C. (2007). *När är det lämpligt att stödja synkron kommunikation i nätbaserade kurser?* Retrieved Jul 19, 2007, from: <http://webnews.textalk.com/se/article.php?id=249502>.
- Hung, D. W. L., & Der-Thanq, C. (2001). Situated cognition, Vygotskian thought and learning from the communities of practice perspective: Implications for the design of web-based e-learning. *Educational Media International*, 38(1), 3-12.
- Iivari, J. (2003). The IS core - VII: Towards information systems as a science of meta-artifacts. *Communications of the Association for Information Systems*, 12(Article 37), 568-581.
- Iivari, J. (in press). A paradigmatic analysis of information systems as a design science. *Scandinavian Journal of Information Systems*.
- Jaldemark, J. (2005). Ett deltagande för alla? En kritisk diskussion. In O. Jobring & U. Carlén (Eds.), *Att förstå lärgemenskaper och mötesplatser på nätet* (pp. 149-172). Lund: Studentlitteratur.
- Jaldemark, J., Lindberg, J. O., & Olofsson, A. D. (2005). Att förstå hur man deltar via redskap i en lärgemenskap. In O. Jobring & U. Carlén (Eds.), *Att förstå lärgemenskaper och mötesplatser på nätet* (pp. 109-147). Lund: Studentlitteratur.
- Jaldemark, J., Lindberg, J. O., & Olofsson, A. D. (2006). Sharing the distance or a distance shared: Social and individual aspects of participation in ICT-supported distance-based teacher education. In M. Chaib & A. K. Svensson (Eds.), *ICT in teacher education: Challenging prospects* (pp. 142-160). Jönköping: Jönköping University Press.

- Jelfs, A., & Colbourn, C. (2002). Virtual seminars and their impact on the rôle of the teaching staff. *Computers & Education*, 38(1-3), 127-136.
- Jeong, A. (2006). Gender interaction patterns and gender participation in computer-supported collaborative argumentation. *American Journal of Distance Education*, 20(4), 195-210.
- Johnson, D. W., & Johnson, R. T. (1999). *Learning together and alone: Cooperative, competitive, and individualistic learning*. Needham Heights: Allyn and Bacon.
- Johnson, D. W., Johnson, R. T., & Stanne, M. B. (2000). *Cooperative learning methods: A meta-analysis*. Retrieved Oct 23, 2007, from: <http://www.cooperation.org/pages/cl-methods.html>.
- Jonassen, D. H., & Land, S. M. (2000). Preface. In D. H. Jonassen & S. M. Land (Eds.), *Theoretical foundations of learning environments* (pp. iii-ix). New Jersey: Lawrence Erlbaum.
- Jones, S. (1995). Understanding community in the information age. In S. Jones (Ed.), *Cybersociety: Computer-mediated communication and community* (pp. 10-35). Thousand Oaks, CA: Sage.
- Jung, I., Choi, S., Lim, C., & Leem, J. (2002). Effects of different types of interaction on learning achievement, satisfaction and participation in web-based instruction. *Innovations in Education and Teaching International*, 39(2), 153-162.
- Kambutu, J. (2002). Administrators prefer technology-mediated distance learning. *Quarterly Review of Distance Education*, 3(3), 341-344.
- Kang, I. (1998). The use of computer-mediated communication: Electronic collaboration and interactivity. In C. J. Bonk & K. S. King (Eds.), *Electronic collaborators: Learner-centered technologies for literacy, apprenticeship, and discourse* (pp. 315-337). Mahwah, NJ: Lawrence Erlbaum Associates.
- Kaplan, A. (1964). *The conduct of enquiry*. New York: Harper Row.
- Kaplan, B., Farzanfar, R., & Friedman, R. H. (2003). Personal relationships with an intelligent interactive telephone health behavior advisor system: A multimethod study using surveys and ethnographic interviews. *International Journal of Medical Informatics*, 71(1), 33-41.
- Karlgren, K. (2003). *Mastering the use of gobbledygook: Studies on the development of expertise through exposure to experienced practitioners' deliberation on authentic problems*. Doctoral thesis, Stockholm University / Royal Institute of Technology, Stockholm.
- Kear, K. (2001). Following the thread in computer conferences. *Computers & Education*, 37(1), 81-99.
- Kearsley, G. (1995). *The nature and value of interaction in distance learning*. Proceedings of the Third Distance Education Research Symposium, Pennsylvania.

- Keegan, D. (1980). On defining distance education. *Distance Education*, 1(1), 13-36.
- Keller, C. (2007). *Virtual learning environments in higher education: A study of user acceptance*. Doctoral thesis, Linköping University, Linköping.
- Keller, C., & Hrastinski, S. (2006). *Learning styles, age and perceptions of online discussions*. Proceedings of the 5th European Conference on e-Learning, Winchester.
- Keller, C., & Hrastinski, S. (2007). Do learning styles matter? In N. Buzzetto-More (Ed.), *Principles of effective online teaching: A handbook for experienced teachers developing eLearning* (pp. 121-135). Santa Rosa, California: Informing Science.
- Kemp, W. C. (2002). Persistence of adult learners in distance education. *The American Journal of Distance Education*, 16(2), 65-81.
- Khan, S. (2005). Listservs in the college science classroom: Evaluating participation and "richness" in computer-mediated discourse. *Journal of Technology and Teacher Education*, 13(2), 325-351.
- Kinshuk, & Chen, N. S. (2006). Synchronous methods and applications in e-learning. *Campus-Wide Information Systems*, 23(3).
- Kinzie, M. B., Whitaker, S. D., & Hofer, M. J. (2005). Instructional uses of instant messaging (IM) during classroom lectures. *Educational Technology & Society*, 8(2), 150-160.
- Klein, J. D. (1997). ETR&D-development: An analysis of content and survey of future direction. *Educational Technology Research and Development*, 45(3), 57-62.
- Kock, N. (2005). Media richness or media naturalness? The evolution of our biological communication apparatus and its influence on our behavior towards e-communication tools. *IEEE Transactions on Professional Communication*, 48(2), 117-130.
- Kock, N., Verville, J., & Garza, V. (2007). Media naturalness and online learning: Findings supporting both the significant- and no-significant-difference perspectives. *Decision Sciences Journal of Innovative Education*, 5(2), 333-355.
- Kolb, D. A. (1984). *Experiential learning. Experience as the source of learning and development*. Englewood Cliffs, NJ: Prentice-Hall.
- Kollerbauer, A., Köhler, H., & Yngström, L. (1973). *Datorstödd undervisning i kursen databehandlingsteknik*. Stockholm: Stockholm University.
- Koschmann, T. (1994). Toward a theory of computer support for collaborative learning. *Journal of the Learning Sciences*, 3(3), 219-225.
- Koschmann, T. (1996). Paradigm shifts and instructional technology: An introduction. In T. Koschmann (Ed.), *CSCL: Theory and practice of an emerging paradigm* (pp. 1-23). New Jersey: Lawrence Erlbaum Associates.

- Kruger, J., & Dunning, D. (1999). Unskilled and unaware of it: How difficulties in recognizing one's own incompetence lead to inflated self-assessments. *Journal of Personality and Social Psychology*, 77(6), 1121-1134.
- Kuboni, O., & Martin, A. (2004). An assessment of support strategies used to facilitate distance students' participation in a web-based learning environment in the University of the West Indies. *Distance Education*, 25(1), 7-29.
- Köhler, H. (1981). *Undervisningssystemering: Ett metodologiskt bidrag till datorstödd undervisning*. Doctoral thesis, Stockholm University, Stockholm.
- Lake, D. (1999). Reducing isolation for distance students: An on-line initiative. *Open Learning*, 14(3), 14-23.
- Lampton, M. A. (1993). Student-faculty informal interaction and the effect on college student outcomes: A review of the literature. *Adolescence*, 28(112), 971-990.
- Lave, J., & Wenger, E. (1991). *Situated learning: Legitimate peripheral participation*. Cambridge: Cambridge University Press.
- Layder, D. (1993). *New strategies in social research*. Cambridge, UK: Polity Press.
- Lee, A. S. (1989). A scientific methodology for MIS case studies. *MIS Quarterly*, 13(1), 33-52.
- Lee, A. S., & Baskerville, R. L. (2003). Generalizing generalizability in information systems research. *Information Systems Research*, 14(3), 221-243.
- Leidner, D. E., & Jarvenpaa, S. L. (1995). The use of information technology to enhance management school education: A theoretical view. *MIS Quarterly*, 19(3), 265-291.
- Ligorio, M. B. (2001). Integrating communication formats: Synchronous versus asynchronous and text-based versus visual. *Computers & Education*, 37(2), 103-125.
- Lincoln, Y. S., & Guba, E. G. (1985). *Naturalistic inquiry*. Newbury Park, California: Sage.
- Lindberg, J. O., & Olofsson, A. D. (2005). *Training teachers through technology: A case study of a distance-based teacher training programme*. Doctoral thesis, Umeå University, Umeå.
- Lindh, J. (1993). *Datorstödd undervisning i skolan: Möjligheter och problem*. Doctoral thesis, Lund University, Lund.
- Lindh, J., Hrastinski, S., & Soames, C. A. (2005). *Same, same but different: A longitudinal study of group work in a distance learning course*. Proceedings of the 4th European Conference on e-Learning, Amsterdam.
- Lindh, J., Hrastinski, S., & Soames, C. A. (2006). *En longitudinell studie av grupparbete i en nätbaserad kurs*. Proceedings of the Netlearning Conference, Ronneby.

- Lindh, J., & Soames, C. A. (2004a). A dual perspective on a university course. *Electronic Journal of e-Learning*, 2(1), 129-134.
- Lindh, J., & Soames, C. A. (2004b). *Improving collaboration in an online course*. Proceedings of the 3rd European Conference on e-Learning, Paris.
- Lindström, K. (2006, Oct 30). Två miljoner svenskar chattar. *ComputerSweden*, p. 4.
- Lipponen, L. (2002). *Exploring foundations for computer-supported collaborative learning*. Proceedings of the The Computer-Supported Collaborative Learning Conference, Boulder, Colorado.
- Lipponen, L., Rahikainen, M., Hakkarainen, K., & Palonen, T. (2002). Effective participation and discourse through a computer network: Investigating elementary students' computer supported interaction. *Journal of Educational Computing Research*, 27(4), 355-384.
- Lipponen, L., Rahikainen, M., Lallimo, J., & Hakkarainen, K. (2003). Patterns of participation and discourse in elementary students' computer-supported collaborative learning. *Learning and Instruction*, 13(5), 487-509.
- Littleton, K., & Häkkinen, P. (1999). Learning together: Understanding the processes of computer-based collaborative learning. In P. Dillenbourg (Ed.), *Collaborative learning: Cognitive and computational approaches* (pp. 20-30). Oxford: Elsevier.
- Lobel, M., Swedburg, R., & Neubauer, M. (2002). The eClassroom used as a teacher's training laboratory to measure the impact of group facilitation on attending, participation, interaction, and involvement. *International Review of Research in Open and Distance Learning*, 3(2).
- Loomis, K. D. (2000). Learning styles and asynchronous learning: Comparing the LASSI model to class performance. *Journal of Asynchronous Learning Networks*, 4(1), 23-32.
- Mabrito, M. (2006). A study of synchronous versus asynchronous collaboration in an online business writing class. *The American Journal of Distance Education*, 20(2), 93-107.
- Macdonald, J. (2003). Assessing online collaborative learning: Process and product. *Computers & Education*, 40(4), 377-391.
- Malmberg, C. (2006). *Kunskapsbygge på nätet: En studie av studenter i dialog*. Doctoral thesis, Malmö University, Malmö.
- March, S. T., & Smith, G. (1995). Design and natural science research on information technology. *Decision Support Systems*, 15(4), 251-266.
- Markus, M. L. (1994). Electronic mail as the medium of managerial choice. *Organization Science*, 5(4), 502-527.

- Marton, F., Dahlgren, L. O., Svensson, L., & Säljö, R. (1977). *Inläring och omvärldsuppfattning: En bok om den studerande människan*. Stockholm: Almqvist & Wiksell.
- Mason, R. (1998). *Globalising education: Trends and applications*. London: Routledge.
- Mason, R. (2000). From distance education to online education. *Internet and Higher Education*, 3(1-2), 63-74.
- Massey, A. P., & Montoya-Weiss, M. M. (2006). Unraveling the temporal fabric of knowledge conversion: A model of media selection and use. *MIS Quarterly*, 30(1), 99-114.
- Masters, K., & Oberprieler, G. (2004). Encouraging equitable online participation through curriculum articulation. *Computers & Education*, 42(4), 319-332.
- Mazzolini, M., & Maddison, S. (2003). Sage, guide or ghost? The effect of instructor intervention on student participation in online discussion forums. *Computers & Education*, 40(3), 237-253.
- McLean, S., & Morrison, D. (2000). Sociodemographic characteristics of learners and participation in computer conferencing. *Journal of Distance Education*, 15(2), 17-36.
- Meece, J. L., Blumenfield, P. C., & Hoyle, R. H. (1988). Students' goal orientations and cognitive engagement in classroom activities. *Journal of Educational Psychology*, 80(4), 514-523.
- Merriam, S. B. (1994). *Fallstudien som forskningsmetod*. Lund: Studentlitteratur.
- Meyer, K. A. (2004). Evaluating online discussions: Four different frames of analysis. *Journal of Asynchronous Learning Networks*, 8(2), 101-114.
- Mikulecky, L. (1998). Diversity, discussion, and participation: Comparing web-based and campus-based adolescent literature classes. *Journal of Adolescent & Adult Literacy*, 42(2), 84-97.
- Miles, M. B., & Huberman, A. M. (1994). *Qualitative data analysis*. Thousand Oaks: Sage.
- Mingers, J. (2006). A critique of statistical modelling in management science from a critical realist perspective: Its role within multimethodology. *Journal of the Operational Research Society*, 57(2), 202-219.
- Moore, G. (1989). Three types of interaction. *The American Journal of Distance Education*, 3(2), 1-6.
- Moore, J. L., & Marra, R. M. (2005). A comparative analysis of online discussion participation protocols. *Journal of Research on Technology in Education*, 38(2), 191-212.
- Moore, M. G. (1973). Towards a theory of independent learning and teaching. *Journal of Higher Education*, 44(9), 661-679.

- Moore, M. G., & Kearsley, G. (1996). *Distance education: A systems view*. Belmont: Wadsworth.
- Mor, Y., & Winters, N. (2007). Design approaches in technology-enhanced learning. *Interactive Learning Environments*, 15(1), 61-75.
- Moreno, J. L. (1934). *Who shall survive? A new approach to the problems of human interrelations*. Washington, DC: Nervous and Mental Disease Publishing Company.
- Morgan, A. R. (1995). Student learning and students' experiences. In F. Lockwood (Ed.), *Open and distance learning today* (pp. 55-66). London: Routledge.
- Morris, K. V., Finnegan, C., & Sz-Shyan, W. (2005). Tracking student behavior, persistence, and achievement in online courses. *Internet and Higher Education*, 8(3), 221-231.
- Morse, J. M. (1999). Myth #93: Reliability and validity are not relevant to qualitative inquiry. *Qualitative Health Research*, 9(6), 717-718.
- Mumford, E. (1983a). *Designing human systems for new technology: The ETHICS method*. Manchester: Manchester Business School Press.
- Mumford, E. (1983b). Participative systems design: Practice and theory. *Journal of Occupational Behaviour*, 4(1), 47-57.
- Münzer, S. (2003). An evaluation of synchronous co-operative distance learning in the field: The importance of instructional design. *Educational Media International*, 40(1-2), 91-100.
- Mårtensson, Y., Larsson, H., & Bergsten, P. O. (1998). *När världen vidgas: Hermodsstudenter berättar: Hermods 100 år*. Malmö: Liber Hermod.
- Newell, S., Robertson, M., Scarbrough, H., & Swan, J. (2002). *Managing knowledge work*. Hampshire: Palgrave Macmillan.
- Nicholson, S. (2002). Socialization in the "virtual hallway": Instant messaging in the asynchronous web-based distance education classroom. *Internet and Higher Education*, 5(4), 363-372.
- Nipper, S. (1989). Third generation distance learning and computer conferencing. In R. Mason & A. A. Kaye (Eds.), *Mindweave: Communication, computers and distance education* (pp. 63-73). Oxford: Pergamon.
- Nuldén, U. (1999). *E-ducation*. Doctoral thesis, Gothenburg University, Gothenburg.
- Offir, B., & Lev, J. (2000). Constructing an aid for evaluating teacher-learner interaction in distance learning. *Educational Media International*, 37(2), 91-97.
- Ohlin, T. (2006). Computer supported examination. In J. J. Bubenko, J. C. Gustaf, A. Kollerbauer, T. Ohlin & L. Yngström (Eds.), *ICT for people: 40 years of academic development in Stockholm* (pp. 173-177). Stockholm: Stockholm University and Royal Institute of Technology.

- Olaniran, B. A. (2006). Applying synchronous computer-mediated communication into course design. *Campus-Wide Information Systems*, 23(3), 210-220.
- Olofsson, A. D., & Lindberg, J. O. (2006). "Whatever happened to the social dimension?" Aspects of learning in a distance-based teacher training programme. *Education and Information Technologies*, 11, 7-20.
- O'Reilly, T. (2005). *What is Web 2.0: Design patterns and business models for the next generation of software*. Retrieved Aug 7, 2007, from: <http://www.oreillynet.com/pub/a/oreilly/tim/news/2005/09/30/what-is-web-20.html>.
- Orlikowski, W. J., & Baroudi, J. J. (1991). Studying information technology in organizations: Research approaches and assumptions. *Information Systems Research*, 2(1), 1-28.
- Orlikowski, W. J., & Iacono, C. S. (2001). Research commentary: Desperately seeking the "IT" in IT research - a call to theorizing the IT artifact. *Information Systems Research*, 12(2), 121-134.
- Palloff, R. M., & Pratt, K. (1999). *Building learning communities in cyberspace: Effective strategies for the online classroom*. San Francisco: Jossey-Bass.
- Palloff, R. M., & Pratt, K. (2005). *Collaborating online: Learning together in community*. San Francisco: Jossey-Bass.
- Parker, A. (1999). A study of variables that predict dropout from distance education. *International Journal of Educational Technology*, 1(2).
- Patton, M. Q. (1990). *Qualitative evaluation and research methods*. Newbury Park, CA: Sage.
- Paulsen, M. F. (2003). *Online education and learning management systems: Global e-learning in a Scandinavian perspective*. Bekkestua, Denmark: NKI.
- Picciano, A. G. (2002). Beyond student perceptions: Issues of interaction, presence, and performance in an online course. *Journal of Asynchronous Learning Networks*, 6(1), 21-40.
- Piccoli, G., Ahmad, R., & Ives, B. (2001). Web-based virtual learning environments: A research framework and a preliminary assessment of effectiveness in basic IT skills training. *MIS Quarterly*, 25(4), 401-426.
- Polanyi, M. (1962). *Personal knowledge: Towards a post-critical philosophy*. Chicago: University of Chicago Press.
- Poole, D. M. (2000). Student participation in a discussion-oriented online course: A case study. *Journal of Research on Computing in Education*, 33(2), 162-167.
- Pratton, J., & Hales, L. W. (1986). The effects of active participation on student learning. *Journal of Educational Research*, 79(4), 210-215.
- Putnam, R. (2000). *Bowling alone: The collapse and revival of American community*. New York: Simon & Schuster.

- Ramsden, P. (1992). *Learning to teach in higher education*. London: Routledge.
- Robert, L. P., & Dennis, A. R. (2005). Paradox of richness: A cognitive model of media choice. *IEEE Transactions on Professional Communication*, 48(1), 10-21.
- Robson, C. (2002). *Real world research: A resource for social scientists and practitioner-researchers*. Malden, MA: Blackwell Publishing.
- Robson, M., & Kaye, A. E. (1989). *Mindweave: Communication, computers and distance education*. Oxford: Pergamon.
- Romiszowski, A., & Mason, R. (2004). Computer-mediated communication. In D. H. Jonassen (Ed.), *Handbook of research for educational communications and technology* (pp. 397-431). New Jersey: Lawrence Erlbaum.
- Ross, J. A. (1996). The influence of computer communication skills on participation in a computer conferencing course. *Journal of Educational Computing Research*, 15(1), 37-52.
- Ross, J. A. (1998). Differential participation of males and females in a computer-mediated communication course. *Canadian Journal of University Continuing Education*, 24(1), 83-100.
- Rovai, A. (2002). Building sense of community at a distance. *International Review of Research in Open and Distance Learning*, 3(1), 1-16.
- Rovai, A. P., Wighting, M. J., & Lucking, R. (2004). The classroom and school community inventory: Development, refinement, and validation of a self-report measure for educational research. *Internet and Higher Education*, 7(4), 263-280.
- Ruberg, L. F., Moore, D. M., & Taylor, C. D. (1996). Student participation, interaction, and regulation in a computer-mediated communication environment: A qualitative study. *Journal of Educational Computing Research*, 14(3), 243-268.
- Russell, T. L. (2001). *The no significant difference phenomenon* (Vol. 5th edition). Montgomery: International Distance Education Certification Center.
- Ryan, R. M., & Deci, E. L. (2000). Intrinsic and extrinsic motivations: Classic definitions and new directions. *Contemporary Educational Psychology*, 25(1), 54-67.
- Salanick, G. R., & Pfeffer, J. (1974). The bases and use of power in organizational decision making: The case of a university. *Administrative Science Quarterly*, 19(4), 453-473.
- Scardamalia, M., & Bereiter, C. (1996). Computer support for knowledge-building communities. In T. Koschmann (Ed.), *CSCL: Theory and practice of an emerging paradigm* (pp. 249-268). Mahwah, New Jersey: Lawrence Erlbaum.
- Schullo, S., Venable, M., Barron, A. E., Kromrey, J. D., Hilbelink, A., & Hohlfeld, T. (2005). *Enhancing online courses with synchronous software: An analysis of*

- strategies and interactions*. Proceedings of the National Educational Computing Conference, Philadelphia, Pennsylvania.
- Schweizer, K., Paechter, M., & Weidenmann, B. (2003). Blended learning as a strategy to improve collaborative task performance. *Journal of Educational Media*, 28(2-3), 211-224.
- Scott, J. (1991). *Social network analysis: A handbook*. Newbury Park, CA: Sage Publications.
- Sfard, A. (1998). On two metaphors for learning and the dangers of choosing just one. *Educational Researcher*, 27(2), 4-13.
- Short, J. A., Williams, F., & Christie, B. (1976). *The social psychology of telecommunications*. New York: Wiley.
- Simon, H. (1988). *The sciences of the artificial* (Vol. 2nd edition). Cambridge, MA: MIT Press.
- Skinner, B. F. (1974). *About behaviorism*. New York: Vintage.
- Slatin, J. M. (1992). Is there a class in this text? Creating knowledge in the electronic classroom. In E. Barrett (Ed.), *Sociomedia: Multimedia, hypermedia, and the social construction of knowledge* (pp. 27-51).
- Spencer, D. (2002). *A field study of the use of synchronous computer-mediated communication in asynchronous learning networks*. Unpublished doctoral thesis, Rutgers University, Newark, New Jersey.
- Sugar, W. A., & Bonk, C. J. (1998). Student role play in the world forum: Analyses of an arctic adventure learning apprenticeship. In C. J. Bonk & K. S. King (Eds.), *Electronic collaborators: Learner-centered technologies for literacy, apprenticeship, and discourse* (pp. 131-155). Mahwah, NJ: Lawrence Erlbaum Associates.
- Sutton, R. I., & Staw, B. M. (1995). What theory is not. *Administrative Science Quarterly*, 40(3), 371-384.
- Swan, K., & Shea, P. (2005). The development of virtual learning communities. In S. R. Hiltz & R. Goldman (Eds.), *Learning together online: Research on asynchronous learning networks* (pp. 239-260). Mahwah, NJ: Lawrence Erlbaum.
- Swanson, E. B., & Ramiller, N. C. (1993). Information systems research thematics: Submissions to a new journal, 1987-1992. *Information Systems Research*, 4(4), 299-330.
- Swedish National Agency for Higher Education (2006). *Universitet & högskolor: Högskoleverkets årsrapport 2006*. Retrieved Jan 26, 2007, from: <http://web2.hsv.se/publikationer/rapporter/2006/0626R.pdf>.

- Swedish National Agency for Higher Education (2007). *Högskoleförordningen*. Retrieved Oct 2, 2007, from: <http://www.hsv.se/publikationerarkiv/lagarochregler/hogskoleforordningen/>.
- Svensson, L. (2002). *Communities of distance education*. Doctoral thesis, Gothenburg University, Gothenburg.
- Säljö, R. (1999). Learning as the use of tools: A sociocultural perspective on the human-technology link. In K. Littleton & P. Light (Eds.), *Learning with computers: Analysing productive interaction* (pp. 144-161). London: Routledge.
- Säljö, R. (2000). *Lärande i praktiken: Ett sociokulturellt perspektiv*. Stockholm: Prisma.
- The European Commission (2000). *Memorandum om livslångt lärande*. Retrieved Feb 8, 2006, from: <http://europa.eu.int/comm/education/policies/lll/life/memosv.pdf>.
- Tholander, J. (2003). *Constructing to learn: Learning to construct*. Doctoral thesis, Stockholm University, Stockholm.
- Tuovinen, J. E. (2000). Factors influencing the success of computer mediated communication (CMC) environments in university teaching: A review and case study. *Educational Media International*, 37(2), 16-24.
- Underwood, J., & Underwood, G. (1999). Task effects on co-operative and collaborative learning with computers. In K. Littleton & P. Light (Eds.), *Learning with computers: Analysing productive interaction* (pp. 10-23). London: Routledge.
- Walls, J. G., Widemeyer, G. R., & El Sawy, O. A. (2004). Assessing information system design theory in perspective: How useful was our 1992 initial rendition? *Journal of Information Technology Theory and Application*, 6(2), 43-58.
- Walsham, G. (2006). Doing interpretative research. *European Journal of Information Systems*, 15(3), 320-330.
- van Aken, J. E. (2005). Management research as a design science: Articulating the research products of mode 2 knowledge production in management. *British Journal of Management*, 16(1), 19-36.
- Wasserman, S., & Faust, K. (1994). *Social network analysis: Methods and applications*. Cambridge: Cambridge University Press.
- Watson, J. B. (1925/1997). *Behaviorism*. New Jersey: Transaction Publishers.
- Webster, J., & Hackley, P. (1997). Teaching effectiveness in technology-mediated distance learning. *Academy of Management Journal*, 40(6), 1282-1309.
- Webster, J., & Watson, R. T. (2002). Analyzing the past to prepare for the future: Writing a literature review. *MIS Quarterly*, 26(2), xiii-xxiii.
- Veerman, A. L., Andriessen, J. E. B., & Kanselaar, G. (2000). Learning through synchronous electronic discussion. *Computers & Education*, 34(3-4), 269-290.

- Wegerif, R. (1998). The social dimension of asynchronous learning networks. *Journal of Asynchronous Learning Networks*, 2(1), 34-49.
- Wellman, B., & Gulia, M. (1999). Virtual communities as communities: Net surfers don't ride alone. In M. Smith & P. Kollock (Eds.), *Communities in cyberspace* (pp. 167-194). London, England: Routledge.
- Wenger, E. (1998). *Communities of practice: Learning, meaning, and identity*. Cambridge: Cambridge University Press.
- Westerberg, P., & Mårald, G. (2006). *Avbrott på nätutbildningar: En studie av när och varför studenter hoppar av alternative fullföljer IT-stödda distanskurser*. Umeå: Centre for Evaluation Research, Umeå University.
- Whitley, E. A., & Galliers, R. D. (2007). An alternative perspective on citation classics: Evidence from the first 10 years of the European Conference on Information Systems. *Information & Management*, 44(5), 441-455.
- Willcocks, L. E. (1996). *Investing in information systems: Evaluation and management*. London: Chapman & Hall.
- Williams, M. L., Paprock, K., & Covington, B. (1999). *Distance learning: The essential guide*. Thousand Oaks, CA: Sage Publications.
- Williams, S., & Pury, C. (2002). Student attitudes toward and participation in electronic discussion. *International Journal of Educational Technology*, 3(1).
- Wilson, B. G. (1996). Introduction: What is a constructivist learning environment? In B. G. Wilson (Ed.), *Constructivist learning environments: Case studies in instructional design* (pp. 3-8). Englewood Cliffs, NJ: Educational Technology Publications.
- Woerner, S. L., Orlikowski, W. J., & Yates, J. (2004). *The media toolbox: Combining media in organizational communication*. Proceedings of the Academy of Management Conference, Atlanta.
- Vonderwell, S., & Zachariah, S. (2005). Factors that influence participation in online learning. *Journal of Research on Technology in Education*, 38(2), 213-230.
- Woods, R., & Keeler, J. (2001). The effect of instructor's use of audio e-mail messages on student participation in and perceptions of online learning: A preliminary case study. *Open Learning*, 16(3), 263-278.
- Woods, R. H. (2002). How much communication is enough in online courses? Exploring the relationship between frequency of instructor-initiated personal email and learner's perceptions of and participation in online learning. *International Journal of Instructional Media*, 29(4), 377-394.
- Vygotsky, L. S. (1978). *Mind in society: The development of higher psychological processes*. Cambridge, Massachusetts: Harvard University Press.
- Wännman Toresson, G. (2002). *Kvinnor skapar kunskap på nätet: Datorbaserad fortbildning för lärare*. Doctoral thesis, Umeå University, Umeå.

- Yin, R. K. (1989). Research design issues in using the case study method to study management information systems. In J. Cash & I. Lawrence (Eds.), *The information systems research challenge: Qualitative research methods* (pp. 1-6). Boston: Harvard Business School Press.
- Yin, R. K. (2003). *Case study research: Design and methods*. Thousand Oaks, CA: Sage Publications.
- Zhang, D., Zhao, J. L., Zhou, L., & Nunamaker, J. F. J. (2004). Can e-learning replace classroom learning? *Communications of the ACM*, 47(5), 75-79.
- Zhu, E. (1998). Learning and mentoring in a distance learning course. In C. J. Bonk & K. S. King (Eds.), *Electronic collaborators: Learner-centered technologies for literacy, apprenticeship, and discourse* (pp. 233-259). Mahwah, NJ: Lawrence Erlbaum Associates.
- Åsberg, R. (2001). Det finns inga kvalitativa metoder – och inga kvantitativa heller för den delen: Det kvalitativa-kvantitativa argumentets missvisande retorik. *Pedagogisk Forskning i Sverige*, 6(4), 270-292.

Appendix A: List of abbreviations

ALN	Asynchronous learning networks
BEO	Business English online
CMC	Computer-mediated communication
CSCL	Computer-supported collaborative learning
CSCW	Computer-supported cooperative work
IM	Instant messaging
KM	Knowledge management

Appendix B: Related publications

2005

- Hrastinski, S. (2005). *Instant messaging use and its effect on student participation in online group work*. Proceedings of the 17th World Conference on Educational Multimedia, Hypermedia and Telecommunications, Montreal.
- Hrastinski, S. (2005). *Introducing a synchronous medium in a computer-mediated distance learning course: Towards understanding how student participation is affected*. Proceedings of the 22nd Conference of the Australasian Society of Computers in Learning in Tertiary Education, Brisbane.
- Hrastinski, S. (2005). *Research on computer-mediated communication in education: Summarizing the past to prepare for the future*. Proceedings of the 17th World Conference on Educational Multimedia, Hypermedia and Telecommunications, Montreal.
- Lindh, J., Hrastinski, S., & Soames, C. A. (2005). *Same, same but different: A longitudinal study of group work in a distance learning course*. Proceedings of the 4th European Conference on e-Learning, Amsterdam.

2006

- Hrastinski, S. (2006). *Participation patterns in small-group asynchronous and synchronous online seminars*. Proceedings of the 5th European Conference on e-Learning, Winchester.
- Hrastinski, S. (2006). *Synkron kommunikation i en distanskurs (Synchronous communication in a distance learning course)*. In O. Jobring, U. Carlén & J. Bergenholtz (Eds.), *Att skapa lärgemenskaper och mötesplatser på nätet* (pp. 215-230). Lund: Studentlitteratur.
- Hrastinski, S., & Keller, C. (2006). *Research approaches on educational technology*. Proceedings of the 3rd Netlearning conference, Ronneby.
- Keller, C., & Hrastinski, S. (2006). *Learning styles, age and perceptions of online discussions*. Proceedings of the 5th European Conference on e-Learning, Winchester.
- Lindh, J., Hrastinski, S., & Soames, C. A. (2006). *En longitudinell studie av grupparbete i en nätbaserad kurs (A longitudinal study of group work in an online course)*. Proceedings of the 3rd Netlearning Conference, Ronneby.

2007

- Hrastinski, S. (2007). Dimensions of synchronous online education. In N. Buzzetto-More (Ed.), *Principles of effective online teaching: A handbook for experienced teachers developing eLearning* (pp. 105-119). Santa Rosa, California: Informing Science.
- Hrastinski, S. (2007). Instant messaging as support for informal synchronous e-collaboration. In N. Kock (Ed.), *Encyclopedia of e-collaboration*. Idea Group.
- Hrastinski, S. (2007). Using chat as a complement to discussion board in small-group online seminars: How is student participation affected? *International Journal of Knowledge and Learning*, 3(5-6).
- Hrastinski, S., & Jaldemark, J. (2007). *Designing for participation in dynamic settings of online education*. Workshop on Interaction Design in Pedagogical Practice, Stockholm.
- Hrastinski, S., & Keller, C. (2007). *När är det lämpligt att stödja synkron kommunikation i nätbaserade kurser?* Retrieved Aug 14, from: <http://webnews.textalk.com/se/article.php?id=249502>.
- Hrastinski, S., Keller, C., & Carlsson, S. A. (2007). *Prescriptive guidelines for when to use synchronous communication in e-learning environments*. Proceedings of the 15th European Conference on Information Systems, St Gallen.
- Hrastinski, S., Keller, C., & Carlsson, S. A. (2007). *Towards a design theory for synchronous communication in online education*. Proceedings of the 2nd International Conference on Design Science Research in Information Systems and Technology, Pasadena.
- Keller, C., & Hrastinski, S. (2007). Do learning styles matter? In N. Buzzetto-More (Ed.), *Principles of effective online teaching: A handbook for experienced teachers developing eLearning* (pp. 121-135). Santa Rosa, California: Informing Science.
- Keller, C., & Hrastinski, S. (2007). *Informing up or down in interactive learning environments?* Workshop on Interaction Design in Pedagogical Practice, Stockholm.
- Keller, C., Hrastinski, S., & Carlsson, S. A. (2007). *Students' acceptance of e-learning environments: A comparative study in Sweden and Lithuania*. Proceedings of the 15th European Conference on Information Systems, St Gallen.
- Keller, C., Lindh, J., & Hrastinski, S. (2007). *E-learning use in higher education: The impact of organisational factors*. Proceedings of the 6th European Conference on e-Learning, Copenhagen.
- Lindh, J., Keller, C., & Hrastinski, S. (2007). *E-learning use in higher education: Driving factors, barriers and strategies*. Proceedings of the 6th Hawaii International Conference on Statistics, Mathematics and Related Fields, Honolulu.

Forthcoming

Hrastinski, S. (in press). Illustrating knowledge networks as sociograms. In M. Lytras, R. Tennyson & P. O. de Pablos (Eds.), *Knowledge networks: The social software perspective*. Idea Group.

Appendix C: Research approaches for studying online student participation

Source	Asyn. media	Syn. media	Quan. meth.	Qual. meth.	Mes./ units	Mess. length	Mess. qual.	Read mess.	Acc. /login	Time spent	Stud. perc.
Ross (1996)	√		√	√		√	√				
Ruberg et al. (1996)	√			√							√
Bullen (1998)	√		√	√	√		√				√
Mikulecky (1998)	√			√			√				
Ross (1998)	√		√	√	√	√	√				
Arbaugh (2000)	√		√		√						
McLean & Morrison (2000)	√		√		√						
Poole (2000)	√		√	√	√	√	√	√	√		
Davidson-Shivers et al. (2001)	√	√	√	√	√		√				
Woods & Keeler (2001)	√		√		√	√					
Jung et al. (2002)	√		√		√						
Lipponen et al. (2002)	√		√	√	√		√				
Lobel et al. (2002)		√	√		√						

Source	Asyn. media	Syn. media	Quan. meth.	Qual. meth.	Mes./ units	Mess. length	Mess. qual.	Read mess.	Acc. /login	Time spent	Stud. perc.
Williams & Pury (2002)	√		√	√	√		√	√			√
Woods (2002)	√		√		√						
Böhlke (2003)		√	√		√						
Ellis (2003)	√		√	√	√				√		√
Hakkarainen & Palonen (2003)	√		√	√	√		√				
Lipponen et al. (2003)	√		√	√	√		√				
Mazzolini & Maddison (2003)	√		√		√						
Carr et al. (2004)		√	√	√	√		√				√
Kuboni & Martin (2004)	√		√	√					√	√	√
Masters & Oberprieler (2004)	√		√		√	√		√			
Davies & Graff (2005)	√		√						√		
Dennen (2005)	√		√	√	√		√				
Khan (2005)	√		√	√	√		√				√
Moore & Marra (2005)	√		√	√	√						√
Vonderwell & Zachariah (2005)	√		√	√	√		√				√
Dahlgren et al. (2006)	√		√	√	√		√				√
Hrastinski (2006a)	√	√	√	√						√	√
Jeong (2006)	√		√		√		√				√
Total (n=31)	28	5	29	20	25	5	16	3	4	2	12

Appendix D: Examples of implications for practitioners

In section 6.4, it was argued that the output of design science research should be to develop abstract knowledge rather than recipes. Below, examples of how the design propositions might be interpreted are provided for different constituent communities, even though it should be borne in mind that the specific situation and context should be taken into account. As exemplified below, the propositions may also have implications for students.

Examples of implications for teachers

Consider supporting synchronous communication if students are expected to complete group projects or work in smaller groups (based on guideline #1). Synchronous communication is useful for less “complex” communication, including planning group tasks and communicating socially, as a complement to asynchronous communication that is useful for enabling “deep” reflection and discussion (based on guideline #2, #3 and #4). Synchronous communication may be used to support formal scheduled learning sessions but also informal communication among students. Some students enjoy communicating informally, by media such as IM and telephone, especially in project groups, while others prefer more formal communication (based on guideline #5 and #6).

Examples of implications for developers of learning environments

Support synchronous communication in the learning environments you develop if the users are expected to complete group projects or work in smaller groups, or may want to communicate socially. Asynchronous

communication is useful for enabling “deep” reflection and discussion. Synchronous communication may support formal scheduled learning sessions but may also enable informal communication, by media such as IM, which can be essential in supporting activities such as group work.

Examples of implications for managers and administrators

Consider supporting synchronous communication if your online programs are expected to include group projects or other activities where students work in smaller groups, or if students may want to communicate socially. Asynchronous communication is useful for enabling “deep” reflection and discussion. There might be reasons to support different types of synchronous communication – this type of communication may support formal scheduled learning sessions but may also enable informal communication, by media such as IM, among students.

Examples of implications for students

Try communicating synchronously when working with group projects or other activities where you work in smaller groups. Other students have found that synchronous communication is useful for planning group tasks and communicating socially while they felt that asynchronous communication was more appropriate for discussing complex issues. Often, teachers use synchronous communication for scheduled sessions but do not forget that it is also possible to communicate informally with peers by, for example, IM and telephone.