



LUND UNIVERSITY

Moisture properties of self-levelling flooring compounds

Anderberg, Anders

2004

[Link to publication](#)

Citation for published version (APA):

Anderberg, A. (2004). *Moisture properties of self-levelling flooring compounds*. [Licentiate Thesis, Division of Building Materials]. Division of Building Materials, LTH, Lund University.

Total number of authors:

1

General rights

Unless other specific re-use rights are stated the following general rights apply:

Copyright and moral rights for the publications made accessible in the public portal are retained by the authors and/or other copyright owners and it is a condition of accessing publications that users recognise and abide by the legal requirements associated with these rights.

- Users may download and print one copy of any publication from the public portal for the purpose of private study or research.
- You may not further distribute the material or use it for any profit-making activity or commercial gain
- You may freely distribute the URL identifying the publication in the public portal

Read more about Creative commons licenses: <https://creativecommons.org/licenses/>

Take down policy

If you believe that this document breaches copyright please contact us providing details, and we will remove access to the work immediately and investigate your claim.

LUND UNIVERSITY

PO Box 117
221 00 Lund
+46 46-222 00 00

LUND INSTITUTE OF TECHNOLOGY
LUND UNIVERSITY

Division of Building Materials

Moisture properties of self-levelling flooring compounds

Anders Anderberg

Second Edition

ISRN LUTVDG/TVBM--04/3120--SE(1-41)
ISSN 0348-7911 TVBM

Lund Institute of Technology
Division of Building Materials
Box 118
SE-221 00 Lund, Sweden

Telephone: 46-46-2227415
Telefax: 46-46-2224427
www.byggnadsmaterial.lth.se

Abstract

During the last decades there has been an increasing interest in the indoor environment and its connections to public health. One aspect has been the relation between moisture in buildings and health. Recent studies have confirmed that moisture or dampness is a risk factor for negative health effects in the indoor environment.

Cementitious materials often contain excess water when being casted as this is necessary for workability and flowing properties. Besides a high water content, the pore solutions in cementitious materials often have a high pH-value. High moisture and high pH conditions can cause chemical reactions in other materials and biological growth, which may influence the indoor environment and the technical function of materials.

Self-levelling flooring compounds (SLC) are used to level substrates (mainly concrete slabs) before applying final floor coverings. Although it is an extensively used product, only limited research has so far been published concerning their moisture properties. This report focuses on moisture properties of SLC and describes methods for determining them. Moisture properties of materials are important for the calculation of drying times and moisture loads and for prediction of ion transport and degradation rates.

In this report, measurements of moisture diffusion and moisture sorption are presented. Measurements were made with three commercial SLC. Later in the project, results from this report will be used when the function of SLC in flooring constructions will be investigated. These investigations will mainly concern transport of moisture and OH^- ions and degradation of other materials in contact with SLC, such as components in flooring adhesives and PVC-floorings.

As traditional determination of moisture properties in cementitious materials is extensive and time consuming work, a simple and rapid method for simultaneous determination of moisture sorption and diffusion has been developed in this project.

Key words

self-levelling flooring compound, flooring screed, SLC, moisture transport, alkali, sorption isotherm, diffusion coefficient, secondary emissions

The included papers

Paper I Moisture Properties of Self-levelling flooring Compounds. Part I. Diffusion Coefficients. **(Submitted)**

Paper II Moisture Properties of Self-levelling Flooring Compounds. Part II. Sorption Isotherms. **(Submitted)**

Paper III Method for simultaneous measurement of sorption isotherm and diffusivity of cementitious materials. **(Draft)**

Paper IV A method for simultaneous measurements of heat of hydration and relative humidity. *Proc. of the Third International Research Seminar on Self-Desiccation and Its importance in Concrete Technology, Lund, June 14-15, 2002*



Preface

This licentiate thesis has been made at division Building Materials, Lund Institute of Technology. The project is part of the industrial research school The Building and its Indoor Environment. KK-stiftelsen and maxit Group are gratefully acknowledged for financing this project.

I thank my supervisors Lars Wadsö at division Building Materials, Lund Institute of Technology, for all help and support and for always taking time and having patience when helping me and Rainer Ålgars at maxit Group for taking time answering all questions and sharing his knowledge and practical experience. A special thanks goes to C-G Nilsson at maxit Group for his support.

I would also like to thank my colleagues at division Building Materials, Bengt, Bosse, Ingemar and Stefan for technical support and laboratory assistance, Britt and Marita for administrative assistance and all other colleges for all valuable discussions and for making this a fun time for me.

Finally I express my gratitude to my family, friends and especially ♡Katarina♡ for all support, care and love given during this time.



Contents

1	Introduction	3
1.1	Sick-building syndrome, SBS	4
1.2	Indoor environmental quality	4
2	Emissions from building materials	7
3	Inorganic binders	11
3.1	Portland cement	11
3.2	Calcium aluminate cement	12
3.3	Calcium sulphates	13
3.4	Inorganic additives	13
3.5	Combination of inorganic binders	13
4	Self-levelling flooring compounds	15
5	Moisture in materials	17
6	Moisture transport	21
7	Moisture in self-levelling flooring compounds	23
8	Alkali	25
9	Summary of papers	29
10	Future investigations	33

Chapter 1

Introduction

During the 19th century the housing conditions of the poor people in Sweden gained increased attention. Connections between housing conditions and mortality were observed [1] and many people had no choice but to live in overcrowded, dirty and insanitary dwellings. The situation was similar around Europe [2].

The overcrowded dwellings left no space for other activities indoors than sleeping and eating. At the end of the century, Stockholm was considered having the worse housing conditions of all capital cities in Europe [2]. Consequently many people spent their spare time outdoors on the streets and in local bars. A debate concerning among other subjects the lack of moral in family life and at work and the crime rate grew during the 19th century. It was believed that the solution of the social and health problems was to provide the population better housing conditions. A house should not only function as a protection against the outside climate, but it also have a social function and give the inhabitants an identity. A good home was believed to be a good base in life and the family was put in focus [3].

Constructing new dwellings, mainly for improving the housing conditions, lasted until the end of the 1960s with the end of the so called million-program in Sweden, where one million dwellings were constructed during a ten year period. Now a couple of decades later we are facing a new situation. The housing conditions are so much improved that people tend to spend most of their spare time indoors. A new debate concerning the sedentary indoor activities and indoor related health effects in modern buildings has replaced former debates.

An average European or US person spends about 90% of her time indoors today [4, 5]. This means that most of the exposures on the human body come in the indoor environment. Our buildings were primary designed to provide a climate shield against precipitation, wind and coldness. During the 20th century this function has gradually

developed through demands from users, authorities and due to the fact that new building materials and construction solutions have been used. A specific indoor environment, almost completely separated from the outdoor environment has been created. In some of these new buildings, a new type of indoor related health problems have occurred. Although it has been present long before, the new type of indoor related health problems reached an increased recognition first around 1965 in USA [6], during the 1970s in Germany [7] and the late 1970s in Sweden [8]. Increased costs for heating lead to tighter buildings with lower ventilation rates and more recirculated air. This, together with new building materials and construction solutions, are suspected to have contributed to the deterioration of the indoor environment and the increase in complain rates.

1.1 Sick-building syndrome, SBS

The health effects related to the indoor environment can be divided into several categories, see for example [9]. The most commonly known is the Sick-Building Syndrome, SBS, which includes irritation in eyes, nose and throat, headaches and fatigue, skin disorders and unpleasant odour and taste perceptions. These symptoms are not possible to relate to single sources and tend to increase with time spent in the building and decrease when leaving the building. However, the term SBS is somewhat diffuse since it is not the buildings that are sick, but the individuals living or working in them. What should be pointed out is that a fraction of individuals normally reports health problems at any time in a building. According to Jones [10] as many as 20% may report SBS symptoms in a healthy office building. Significantly higher levels of complaints must be shown before classifying a building as "sick".

Another type of disorder that should not be confused with SBS is the so called Building Related Illness, BRI. BRI has a known etiology with specific symptoms that can be directly connected to a certain factor in the building, e.g. Legionnaire's disease [9]. However, the distinction between BRI and SBS is not always clear [11].

1.2 Indoor environmental quality

Several attempts to explain the reasons for health effects in indoor environments has been made. Although extensive research have been performed, with few exceptions like environmental tobacco smoke, house dust mites and radon [12], it is not known what agents in the indoor environment that causes the health effects. Several large studies have been performed trying to relate agents in the indoor environment to health. However, since the sampling and analysis technique of today do not register all agents in the indoor air, there may be important agents missing in the studies performed up

till today.

Jones [13] divides factors contributing to indoor air quality problems into four categories: chemical, physical, biological and psychological. These factors are discussed below.

Chemical factors

Chemical factors are mainly emission of molecules from for example building materials, furnishing, personal care products, cleaning products and house/office equipment. Health effects for some emissions, e.g., benzene, toluene and formaldehyde, are known for high levels of exposures, but not for typical levels present in the indoor environment of today. Questions have been raised whether the relevant pollutants have been measured [14]. Some potential irritants, like radicals from gas phase reaction, are not easily detected with the measuring techniques of today. One possible source of such irritants is ozone [15], which might react with unsaturated organic compounds in the indoor air forming irritants. Emissions from building materials are further described in chapter 2.

Physical factors

Physical factors include for example temperature, light, noise and humidity. Humidity is an often discussed subject, not because its direct impact on human health, but because it indirect influences and promotes degradation processes. It has been found that dampness or humidity increases the risk for health effects in airways, tiredness and headache [16]. This seems to be true irrespectively of if the dampness is measured as condensation on windowpanes, water damage or smell/odour. However, it is not known what the connection between dampness and health effects is. Two discussed possibilities are emissions from degraded building materials and emissions from microbial growth. Both chemical degradation processes and microbial growth increase with increasing moisture content as the molecular mobility of chemical reactants and microbial nutrients then increases [17].

Ventilation is a frequently discussed factor as its function is to transport emissions, particles, moisture, odours, etc. out of buildings and supply the buildings with fresh air. According to several studies, an increased outdoor air supply rate reduces the risk of health symptoms in non-industrial environments [18].

Biological factors

Biological factors include for example mould and bacteria, but also emissions from humans, pets and indoor plants. The key factor for microbiological growth indoors is

humidity. Other influencing factors, like temperature, nutrients and oxygen, are nearly always at sufficient levels for biological growth indoors. Potential agents that are suspected to contribute to health effects deriving from biological growth are, e.g., proteins, mycotoxins, glucans and MVOC (microbial volatiles) [19]. MVOC are volatile emissions of alcohols, ketones, esters, etc., released during microbial growth while mycotoxins are toxic metabolites produced during mould growth. Mycotoxins may be deposited in the airways when spores are inhaled [20]. While it is not known which agents that are responsible for health effects [21] it has been found that repeated exposure to high levels of biological agents is a risk factor for development of specific allergic reactions [20]. Once the immune system has been triggered, the allergic reaction may be started by exposures to even very low levels of allergens.

Psychological factors

In the literature, psychological factors are mainly connected to the office environments. Factors such as labour relations and office culture are mentioned, but also stress in general [22], which influences individuals in all environments.

Chapter 2

Emissions from building materials

Emission is something that is discharged or released (emitted), for example heat, light, sound, gas, or radiation [23]. However, in this report the word emission will refer only to gases and vapours excluding water vapour. This is often called chemical emissions.

Emissions in the indoor environment may come from for example building materials, microbial growth, human activities or through outdoor air exchange. Emissions in buildings are normally highest when the buildings are newly constructed or renovated. According to Brown [24], concentrations of VOC (Volatile Organic Compounds) are normally about an order of magnitude (tenfold) higher in new buildings. The emissions then strongly decrease during the first six months [25]. An investigation on primary emissions (see below) from flooring materials presented in [26] reports a decrease of about 2/3 between one and six months of age. These initial emissions come from construction materials and building contents [24], for example from paints, adhesives and furniture.

Emissions from materials are here divided into two main categories: primary emissions and secondary emissions. Primary emissions are emissions from single materials not influenced by other materials. In principle, primary emissions decay with time under constant conditions, but in reality emissions may vary with for example temperature and moisture content. Examples of primary emissions are formaldehyde from chipboard, solvents from adhesives and paints, ammonia from Portland cement based materials and terpenes from wood. Production development, new measurement techniques and labelling system have lead to development of low emitting materials and a general decrease in primary emissions.

Secondary emissions come from degrading processes like oxidation and hydrolysis [27] that give rise to volatile compounds. These processes may occur in both single materials as well as in combinations of materials when the materials in some way

interact, e.g., flooring adhesives [28] and PVC-flooring [29] on moist concrete. Secondary emissions are suspected to have a greater impact on health than primary emissions [30].

The dominant group of emissions are organic compounds. Such emissions are normally divided into different groups depending on their volatility. The most common group related to indoor environment is VOC, Volatile Organic Compounds, which have boiling points in the range of 50-100 to 240-260 °C [4]. VOCs in building materials can be measured with for example FLEC (Field and Laboratory Emission Cell) [31] and chamber methods [32], where emissions are collected on a sorbent and later analysed in a laboratory. Results from measurements are normally presented as emission rates, $\mu\text{g}/(\text{m}^2 \times \text{h})$. Besides VOC, more volatile compounds like formaldehyde (VVOC Very Volatile Organic Compounds) and ammonia are frequently measured. Larger molecules like plasticizers and cosolvents in paints are classified as SVOC (SemiVolatile Organic Compounds). Two other definitions are POM (Particulate Organic Matter) and MVOC (Microbial Volatile Organic Compounds).

VOC can be measured individually or as a total, TVOC (Total VOC). VOC are most likely a cause of health effects and discomfort in indoor environments [33, 34], but as different VOC have different health impact, neither VOC, nor TVOC have been found to be relevant risk indices for indoor air quality [33]. However, due to limitations in measurement techniques and knowledge, TVOC is still commonly used when measuring indoor air quality.

Inorganic binders in the pure state do not produce any significant primary emissions, but additives like grinding aids for Portland cement and admixtures to concretes or mortars may give rise to measurable amounts of emissions. Of more importance for the indoor environment are secondary emissions from materials being degraded in contact with moist cement based materials, Figure 2.1. Concrete is cast with water and forms a dense fine porous material containing large amounts of highly alkaline pore water. If the concrete is not sufficiently dried out the pore solution will come in contact with the the adhesive and flooring material, possible degrading it by alkaline hydrolysis. As production time has decreased during the last decades, drying times have shortened considerably. Several investigation on drying of concrete and limits for when other materials can be applied to concrete and other types of cementitious materials have been performed, both concerning moisture and alkali, see for example [29, 35, 36, 37].

Today primary emissions are measured for most indoor surface materials and there are several standards regarding measurement of primary emissions from building materials. Measuring secondary emissions is of a more complex nature as this can include several different materials reacting during long time periods. Such test may therefore give completely different results if made under different conditions. A standard method for

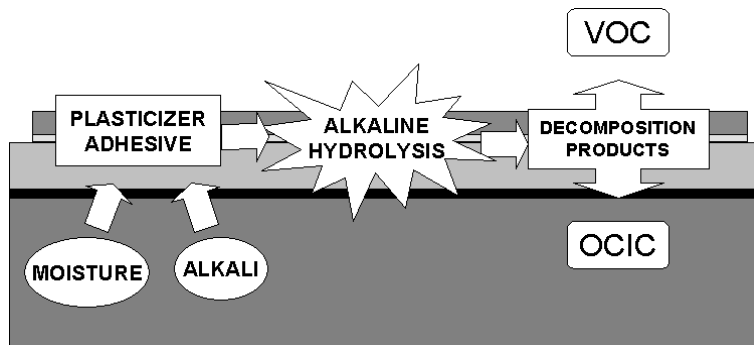

Figure 2.1: Model of decomposition process adapted from Sjöberg [28]. Alkali is at high moisture loads transported from a concrete slab up to the floor adhesive and top flooring where an alkaline hydrolysis may occur. Reaction products may emit to the indoor air, VOC, or be stored in the concrete, OCIC (Organic Compound In Concrete).

measuring emissions from bonded flooring constructions on concrete has been developed in Sweden [38]. In this method a reference construction is compared with the desired construction, thus giving the possibility to test different combinations of materials.

Chapter 3

Inorganic binders

Inorganic binders are generally used to hold solid particles together in concrete, mortars, etc. Solid particles used with inorganic binders are for example sand, gravel and lime stone filler. Inorganic binders are normally divided into two groups, hydraulic and non-hydraulic binders. Hydraulic binders like Portland cement and aluminate cement, sets and hardens by reaction with water. The reaction takes part in air as well as under water and the reaction products are resistant to water. There are also non-hydraulic binders like lime that need carbon dioxide to form the end product.

3.1 Portland cement

The most commonly used inorganic binder is Portland cement (PC). PC is made of limestone and clay or other materials with similar chemical components. These raw materials are burnt at about 1450 °C, rapidly cooled and ground together with gypsum. The latter is added to prevent flash setting. Grinding aids are also added to improve the milling. The main clinker components are impure forms of alite (Ca_3SiO_5), belite (Ca_2SiO_4), aluminate ($\text{Ca}_3\text{Al}_2\text{O}_3$) and ferrite ($\text{Ca}_2\text{AlFeO}_5$). Several other phases, e.g., alkali sulphates and calcium oxide normally exists in minor amounts [39], which may have an impact on the final product. On reaction, the main clinker component, alite, reacts with water forming C-S-H¹ gel and $\text{Ca}(\text{OH})_2$:

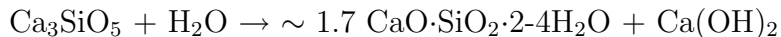

Belite reacts in a similar way as alite, but less $\text{Ca}(\text{OH})_2$ is formed.

¹Often are shorthand notations used in cement chemistry, where C=CaO, A=Al₂O₃, F=Fe₂O₃, S=SiO₂, H=H₂O \bar{S} =SO₃, but in this report are full chemical formulae given except in the term "C-S-H".

When Portland cement reacts, the reaction products are formed as a layer of C-S-H gel on the surface of the cement grains. This layer slows down further hydration by hindering the contact between the unreacted core of the cement grain and the water. A model of the microstructure and its development in a Portland cement was developed during the middle of the last century by Powers [40]. According to this model the finest level of structure is a very fine porous material called cement gel. Later, other models mainly describing the finest level of structure in different ways have been developed.

3.2 Calcium aluminate cement

Calcium aluminate cement, CAC, was developed in the late 1800s. It was found to be resistant to sulphate attack and to have a very rapid strength development. However, long term conversion of the hydrated products, which under some circumstances lead to a decrease in long term performance has limited its usage. Today there are three main areas of use of CAC [41]:

- Refractory concrete (for high temperature exposure).
- As the main binder phase of special concretes, for example when rapid hardening, high abrasion resistance and high resistance to chemical attacks are desired.
- As a component in blended system with special properties, for example self-levelling flooring compounds.

The raw materials are normally bauxite and lime stone, which are melted at about 1500-1600 °C, cooled and ground without grinding aid. The most important clinker components are CaAl_2O_4 , $\text{Ca}_2\text{AlFeO}_5$ and $\text{Ca}_{12}\text{Al}_{14}\text{O}_{33}$. When reacting with water under normal temperatures, the main component, CaAl_2O_4 , forms $\text{CaAl}_2(\text{OH})_8 \cdot 6\text{H}_2\text{O}$ and $\text{Ca}_2\text{Al}_2(\text{OH})_{10} \cdot 3\text{H}_2\text{O}$. These hydration products are not stable and tends to convert into $\text{Ca}_3\text{Al}_2(\text{OH})_{12}$ and $\text{Al}(\text{OH})_3$:

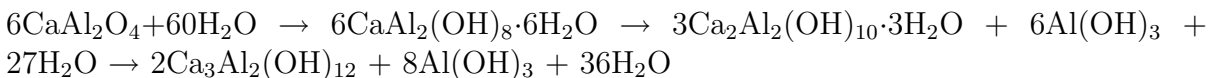

The conversion products are less voluminous resulting in a weaker product. The conversion rate is dependent on for example temperature and moisture state. The consequences of the conversion can be reduced by using low water to cement ratios (<0.4) and >400 kg cement per m³ concrete [39].

When aluminate cement is mixed with water, the clinker components dissolves from the cement grains and reaction products are formed in the solution. Because of

this the strength development of CAC normally is much faster than in PC where the reaction products are formed on the cement grain slowing down further reaction.

3.3 Calcium sulphates

Calcium sulphates ($\text{CaSO}_4 \cdot x\text{H}_2\text{O}$) are added of different reasons to cement mixes, for example for preventing flash setting in PC, shrinkage compensation and enable self-desiccation at high water to binder ratios. They exist in several forms with different amount of crystal water, both as natural and as industrial products. Normally calcium sulphates are divided into three groups, dihydrate (gypsum) ($x=2$), hemihydrate ($x=0.5$) and anhydrite ($x=0$). When mixed with water, hemihydrate forms gypsum relatively fast while natural anhydrite (anhydrite II) needs an accelerator to form gypsum.

3.4 Inorganic additives

Today it is common to use industrial byproducts and other materials as additives in cements. When added to cement, these additives normally give a less porous product with higher strength. They can also be used to replace a part of the cement.

Blast furnace slag and fly ash containing reactive silica and higher contents of calcium are called latent hydraulic as they can react and form hydraulic products if an activator, for example calcium hydroxide or alkalis are present [39]. Fly ash containing low amounts of calcium, silica fume and volcanic ash are called pozzolanas. As latent hydraulic additives they contain reactive silica, but they need CaO to react and form C-S-H gel. The C-S-H gel in such mixtures has a lower Ca/Si ratio than in mixtures based on PC. If aluminates are present, calcium aluminate hydrates and aluminate silicate hydrates are also formed.

Limestone filler (ground limestone) is sometimes added or interground with cement. It both acts as a filler between other grains as well as reacts moderately with clinker components.

3.5 Combination of inorganic binders

Aluminate cement and calcium sulphate

When aluminate cement and calcium sulphate reacts, the main reaction products are ettringite, $[\text{Ca}_3\text{Al}(\text{OH})_6]_2(\text{SO}_4)_3 \cdot 26\text{H}_2\text{O}$ and aluminate hydrates. Ettringite forms very fast as long as sulphates are available. If the access of sulphate decreases towards zero

and calcium still is widely available, ettringite will start to transform into monosulphates ($[\text{Ca}_4\text{Al}_2(\text{OH})_{12}]\text{SO}_4 \cdot 6\text{H}_2\text{O}$), a molecule with lower S/Ca-ratio. Ettringite consists of almost 50 weight % water and is therefore often used in products where self-desiccation is wanted [42].

When Portland cement is added to aluminate cement and calcium sulphate, C-S-H gel is also formed. The addition of Portland cement to aluminate cement strongly reduces the setting time.

Chapter 4

Self-levelling flooring compounds

The first pumpable self-levelling flooring compound, SLC, was developed in the middle of the 1970s. Portland cement was used as a binder together with a casein based flowing agent. The aim with the product was to achieve an easy and fast way to level off concrete floors before applying a top-flooring. Instead of having to after-treat the concrete surface, which often is hard work, it was now possible to produce smooth and horizontal surfaces with a pumpable cement based mortar. The product rapidly gained popularity on the Swedish market and in the beginning of the 1980s, the product was used on almost 90% of the produced concrete floors [43].

However, complaints soon started to arise. People living or working in buildings with concrete slabs claimed that they did not feel well when being in these buildings. The symptoms were related to the "sick-building syndrome", see 1.1. Oak parquets and cork floorings sometimes became stained. Several large investigations started and ammonia from the casein flowing agent was found to be the reason for the discolouration on the parquet and cork flooring. The casein was also suspected, although it has never been proven, to be a contributing factor to the health symptoms, related to SBS, reported in these buildings [8, 44]. When degraded, odourous volatile products like ammonia and amines are formed.

Casein is a protein, prepared through precipitation of milk with e.g. rennet. Similar proteins can also be obtained from other species in the animal or vegetable kingdom [43]. Casein products had been used for decades in building materials, but was now found to degrade under the moist alkaline conditions often present in concrete slabs [45].

As casein was suspected to contribute to poor indoor environment, nordic producers of SLC developed formulas without casein. In the new formulas casein was replaced by synthetic flowing agents, but also the binders were changed. The new binding systems were mixtures of different types of cements and calcium sulphates. This new

binder system has a lower pH, making the final product less aggressive to other materials.

Today SLC are still widely used in Sweden, a rough estimation is that about 70% of the produced floors in Sweden are levelled with SLC. In central and especially southern Europe this figure is significantly lower.

Besides SLC with synthetic flowing agents, SLC with casein as flowing agent are still manufactured outside the nordic countries and there are also SLC without cement, mainly using calcium sulphates as binders. However, this report is focused on cement based SLC with synthetic flowing agents.

SLC consist of binders, filling materials, redispersible polymers and admixtures, Table 4.1. The binders are normally a mixture of calcium aluminate cement (CAC), Portland cement (PC) and calcium sulphate in the forms of anhydrite and hemihydrate. This binder system makes it possible to formulate rapid-hardening, rapid-drying and shrinkage compensating formulas with relatively high water to binder ratios. A redispersible polymer powder is added to improve surface abrasion resistance and flexural and tensile strength. The polymer particles coalesce and form a film [46] that can be described as an interspersed secondary binder system [47]. Filling materials are sand and finely ground mineral materials, e.g., limestone. The admixtures control for example setting time, curing time, flowing characteristics, air entrainment and separation. A normal SLC contains about 15 different ingredients making it a very complex product.

Table 4.1: Formula of a typical SLC, partly adapted from [48]

Component	Approximate quantity [%]	Main function
Calcium aluminate cement	17	Binder
Portland cement	3	Binder
Calcium sulphate	7	Binder
Limestone	30	Filling material
Sand	45-50	Filling material
Redispersible polymer		Improvement of flexural strength, tensile strength and abrasion resistance
Thickener		Prevents bleeding and segregation
Flowing agent		Improves self-levelling properties and reduces water demand
Retarder		Increases open time
Accelerator		Increases rapidness of early strength development
Defoamer		Reduces air entrainment during mixing

Chapter 5

Moisture in materials

Moisture is not only correlated to indoor environmental problems, but also of interest to processes in materials such as growth of rot fungi in wood, corrosion of steel, shrinkage and swelling and frost damage. A general introduction to moisture in materials will here be given.

The availability of moisture in materials is expressed as water activity (a_w) which is defined as the ratio of vapour pressure of water in the material to the vapour pressure of pure water [49]. The term relative humidity (RH) is the water vapour pressure of air at a given temperature expressed as a percentage of the water vapour pressure at saturation [50]. A ratio of vapour content can also be used as vapour contents are proportional to pressures at constant temperature. The terms a_w and RH are sometimes used interchangeably in some fields of science, for example in building materials science where one may say that a piece of wood has a relative humidity of 70%. At equilibrium, the water activity is related to the relative humidity of the surrounding atmosphere by [51]:

$$a_w = RH(\%)/100$$

Water activity is thought to be a measure of the availability of water. The rates of processes involving water should then be dependent on the water activity. As an example, it is generally thought that an a_w of at least 0.8 is needed for biological growth, although some species can grow at lower a_w [17, 19]. However, chemical reactions are also dependent on transport properties, as reactants have to come in contact with each other so the moisture content may also be of interest.

Moisture in materials is normally divided into different categories or groups depending on how hard the water molecules are bound to the surface or structure of the material. This is important as not all water inside materials contribute to biological growth, transport of substances, chemical reactions, etc. The weakest bound water is here the most interesting [17].

The strongest bound water in a cementitious material is chemically bound as reaction products in the hardened cement paste and is thus part of the solid structure of the material. As this water is strongly bound in the structure and does not leave the material under normal circumstances it is of no interest concerning indoor environmental aspects.

Physically bound water stands in equilibrium with the surrounding atmosphere. The amount of water in a material, excluding chemically bound water, is normally given as the sorption isotherm, i.e., the relation between the moisture content and the a_w , at constant temperature and constant total pressure.

Physically bound water can either be adsorbed to surfaces in the material, absorbed to the structure of the material or capillary condensed on water menisci formed in pores. The first layer of adsorbed water is the strongest bound, most immobile and unfreezable at $-40\text{ }^\circ\text{C}$ [17]. This water behaves as part of the solid and corresponds to the monolayer moisture content. A monolayer can be seen as when all of the dry matter is covered with one layer of water molecules [52]. Further added water is more mobile. When sufficiently abundant, this water allows microbial growth, ion transport and chemical reactions to occur in solution.

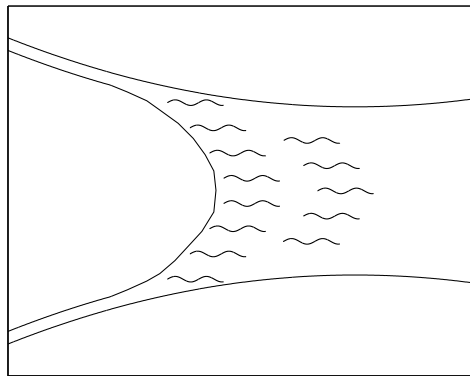

Figure 5.1: Schematic drawing of water meniscus formed in a pore.

In porous materials water is bound not only by adsorption but also by capillary condensation. Water molecules then condense on concave water menisci. A part the of pores are then completely water filled, see Figure 5.1. The curvature of the menisci corresponds to a certain equilibrium pressure of water, Figure 5.2. The smaller the

radius, the lower the equilibrium pressure. This relation can be expressed with the Kelvin equation [52]:

$$RT \ln\left(\frac{P}{P_0}\right) = \frac{2\gamma V}{R_m}$$

where R is the gas constant ($8.315 \text{ JK}^{-1}\text{mol}^{-1}$), T is the temperature (K), P is the vapour pressure over the meniscus (Nm^{-2}), P_0 is the vapour pressure of pure liquid (Nm^{-2}), γ is the surface tension (Nm^{-1}), V ($\text{m}^3\text{mol}^{-1}$) is the molar volume and R_m is the mean radius of curvature of the meniscus (m). When a material is in equilibrium at low RH, only small water menisci can exist, i.e., only small pores can be completely water filled. At higher RH, larger water menisci can form and pores with larger pores radius can be water filled. In a fine-porous material, capillary condensed water is the dominant contributor to microbial growth, transport processes and chemical reactions.

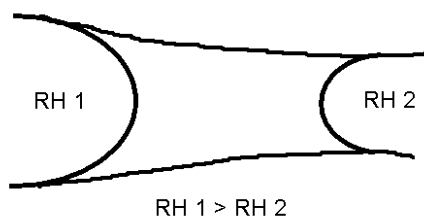

Figure 5.2: Water menisci in a pore. The smaller meniscus corresponds to a lower RH. The water will tend to move towards the lower RH.

A consequence of capillary condensation is sorption hysteresis [52], that is, a material will contain different amounts of water in equilibrium with a certain RH, depending on whether the material is drying or taking up moisture, Figure 5.3. A material taking up moisture never contains more water than a drying material at the same RH.

As can be seen in Figure 5.3 a sorption isotherm has one curve for desorption and one for absorption. If a drying material is rewetted it follows a scanning curve from the desorption isotherm to the absorption isotherm, and vice versa. A result of this is that a small increase in moisture content may lead to a large increase in water activity (RH). A consequence of this for moisture related processes is that one parameter, water activity, cannot solely describe the rate of biological and chemical processes [17]. Moisture content may as well be necessary to take into consideration, which has been seen for microbial growth on food stuffs [53].

The sorption isotherm is, as the name indicates, only valid at a given temperature. An increase in temperature results in an increase in a_w at a constant moisture

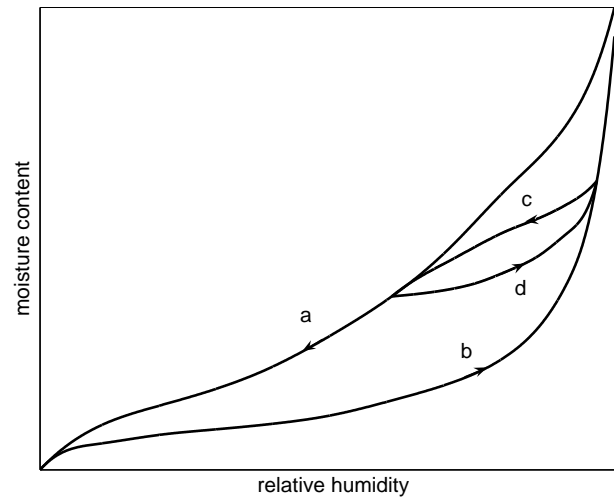

Figure 5.3: An example of a sorption isotherm with two sorption limbs, a (desorption) and b (absorption), and two scanning curves c and d.

content [17, 54], opposite to air, where an increase in temperature results in a lower RH. For concrete, a temperature dependence of 0-0.4% RH per °C, dependent on moisture condition, has been seen [55]. Other substances may show a stronger dependence, for example for some food stuffs a temperature increase of 10 °C resulted in an increase in a_w up to about 0.20 [51]. An increase in temperature normally increases the rate of physical and chemical reactions [56].

Chapter 6

Moisture transport

Moisture transport occurs in all porous media where a driving force is present. The driving force may be either a concentration gradient or an external pressure. If there is an external pressure gradient through a material, moisture either in liquid phase (water) or vapour phase (in air) is forced through the material. This type moisture transport will not be further discussed here as it is not relevant in this investigation.

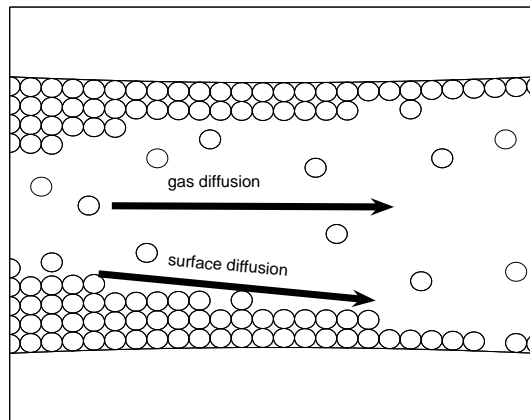

Figure 6.1: Schematic picture of diffusion in a pore, where molecules in random motion tend to move towards lower concentration.

Moisture transport due to a concentration gradient is divided into two types: vapour transport and capillary transport. Vapour transport occurs in non water filled pores and is further divided into Knudsen diffusion, surface diffusion and ordinary diffusion [57]. Diffusion is a net flow of molecules due to random motion from a region with higher

concentration to a region with lower concentration of molecules. Knudsen diffusion is diffusion in very small pores where the collision between molecules and pore walls have a significant influence on the rate of diffusion. Surface diffusion is the movement of the bound adsorbate, where water molecules move between adsorption sites, see Figure 6.1. Capillary transport occurs in water filled pores due to pressure differences in water menisci, Figure 5.2. Since it normally is of no interest to separate the different transport mechanisms, the total moisture flow is usually described. This is given by Fick's law:

$$q_m = -D_c \frac{dc}{dx}$$

where q_m ($\text{kgm}^{-2}\text{s}^{-1}$) is the flux, D_c (m^2s^{-1}) is the diffusion coefficient, and dc (kgm^{-3}) is the concentration difference over the distance dx (m), the moisture gradient. Other formulations of Fick's law use vapour pressure, relative humidity or other moisture potentials. Moisture transport is normally dependent on moisture state and temperature in

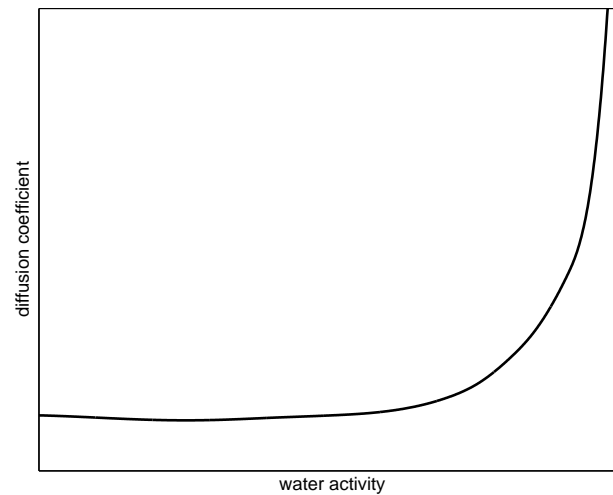

Figure 6.2: An example of a diffusion coefficient as a function the water activity a_w .

the material. A typical relation between diffusion coefficient and a_w for a cementitious material is shown in Figure 6.2.

Chapter 7

Moisture in self-levelling flooring compounds

When water reacts with inorganic binders, hydration products are formed. The reaction consumes both binder and water and the reactants are chemically bound in the reaction products. This means that part of the mixing water will be chemically bound in the material. The reaction products normally have less volume than the reactants, meaning that a volume reduction occurs during hydration. A fine pore system is created during hydration, which will be partly air filled due to the volume reduction. In a sealed system all mixing water that is not consumed due to chemical reaction will remain in the pores either as physically bound water or as free water.

SLC normally have high water to binder ratios (w/b) due to the desired self-levelling properties. A low w/b tends to give the fresh mortar a too stiff consistency. A consequence of high w/b may be that part of the water will separate from the mortar and form a water film on the surface (bleeding). The separated water includes additives such as the polymer. As the surface water evaporates, the polymers are left in the surface region. Besides influencing mechanical properties, the higher amount of polymers in the surface may influence moisture transport properties by adding an extra resistance to moisture flow to the surface.

Self-desiccation occurs in materials where water is chemically bound in the solid structure. The lowering of the a_w , or pore relative humidity, is partly due to the fact that water is chemically bound in hydration products, but more important is the fine pore system that is created during hydration. In this pore system, water is bound both as surface adsorption and by capillary condensation. The harder the water is bound, the lower will the corresponding relative humidity of the bound water be, thus the characteristics of the pores strongly influences the self-desiccation.

An SLC dries as a result of three different processes: evaporation from surface, self-desiccation and suction or diffusion into the substrate (usually concrete). When newly casted, a water film is formed on the surface due to wetting of the top grains in the SLC and bleeding. The rate of evaporation then only depends on the surrounding climate (RH, temperature and air velocity). This phase of the surface evaporation normally lasts up to a couple of hours. As the surface dries, the water front recedes into the substrate and the rate of the evaporation from the surface will then also depend on the diffusion resistance inside the material. The diffusion increases by an increase in temperature and a decrease in the relative humidity in the surrounding air. As time goes, more and more reaction products will be formed, which slows down further diffusion. The water activity inside the material will also decrease as the remaining water will be harder and harder bound in the developing pore system. Depending on substrate and possible surface treatment on the substrate, water may also diffuse or be sucked downwards.

The main reaction product in SLC treated in this report is ettringite, which consists of almost 50 weight-% water [42]. Parts of this chemically bound water will be released (some irreversibly) when drying at temperatures above 60 °C [58], drying over desiccants or by vacuum drying [59] at room temperature.

Chapter 8

Alkali

The term alkali mainly refers to soluble hydroxides of the alkali metals (Na, K, etc.), which are strong bases, but also to the hydroxides of earth alkaline metals (like Ca) [60]. Here alkali will refer to the anion in these hydroxides, i.e., the hydroxide ion (OH^-).

The pore solutions of cementitious materials have high pH-values as OH^- and cations such as Ca^{2+} , K^+ , and Na^+ are products of the hydration reactions. pH in a concrete is about 12.5-14 [61]. The pH of SLC treated in this report is lower, about 11 [62]. When exposed to air the pH-value of all cementitious materials will decrease due to carbonation (reaction with dissolved carbon dioxide in solution). The rate of this process is moisture dependent as the diffusion process of gases is several orders of magnitude faster in air than in liquid. However, as the reactions are taking place in the pore solution, there is an optimum of moisture content for the rate of carbonation.

The carbonation depth is generally considered to be proportional to the square root of time [63]. However, in a hydrating and drying material this will not be the case as for example pore structure and moisture state are changing with time. As an example, Table 8.1 gives carbonation depths as a function of time for the three flooring compounds described in article I and II.

Cementitious materials often have highly alkaline pore solutions. Other materials that come in contact with these alkaline pore solutions may be degraded. The most commonly discussed such process is the degradation of polymers and other organic molecules by alkaline hydrolysis. A common degradation process in alkaline environment is the hydrolysis of ester groups which may give emissions of 2-ethylhexanol [37]:

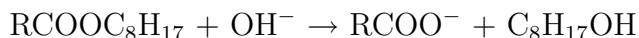

where R is an organic group. The alkalinity (pH) in combination with the relative humidity in the material are key factors for this type of degradation processes

Table 8.1: Depth of carbonation as function of time in SLC used in paper I and II. Test specimens were 25 mm thick, exposed to air from one side and stored at 20 °C, 55% RH. The depth of penetration was determined by splitting test specimens and spraying the surface with a pH-indicator, phenolphthalein or thymol blue . As it was hard to see the colour change of phenolphthalein for SLC A and B, thymol blue was used for these SLC in the end of the investigation (marked *).

time (days)	\sqrt{time} (\sqrt{days})	Depth of carbonation (mm)		
		SLC A	SLC B	SLC C
11	3.3	3	4	5
18	4.2	6	5	5
29	5.4	6	8	5
36	6	7	6	4
59	7.7	18*	9*	9
70	8.4	20*	10*	9

[28, 36]. Moisture is essential as it acts as a transport medium for hydroxide ions that react with components in other materials. Besides moisture state and pH, an increase in temperature has also been found to increase the rate of alkaline hydrolysis [64].

An increase in pH in the surface areas of cementitious materials have been noted after casting in some studies [62, 65]. This is caused by hydroxide ions transported with mixing water to the surface area where water evaporates and hydroxide ions thus accumulate.

Björk et al. [37] studied transport of hydroxide ions from concrete to SLC at various RH. They found that after about 6 months there was still a significant difference in pH between the top of the concrete and the bottom of the flooring compound indicating that only minor transports of hydroxide ions had occurred. pH was measured with pH-electrode both on debris from drilling mixed with water and pore water from pore water squeezing.

Björk et al. [37] have also developed a method for studying influence of both relative humidity and pH on degradation of components. The components to be tested are placed in an alkaline powder in a headspace vial where the RH is controlled by a saturated salt solution. Sampling of volatile degradation products is done in the headspace above the specimen. A problem with this method is that it may be difficult to control pH and RH independent of each other using two salts, as the salts will tend to come in RH-equilibrium.

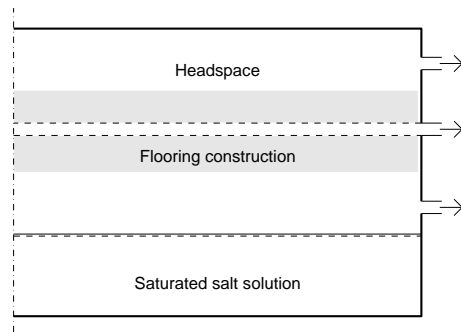

Figure 8.1: Schematic picture of test setup in [66].

Sjöberg and Anderberg [66] have developed a method where a flooring construction is placed on a container with a saturated salt solution, controlling the RH, see fig 8.1. The construction may consist of any cementitious material and top flooring. Sampling may be done under, above or from inside the flooring construction as a perforated steel tube is casted in the construction. The set-up is connected to a detecting instrument (Brüel & Kjaer 1302), which continuously measures levels of degradation products.

Chapter 9

Summary of papers

The aim of the work presented in this report has been on characterizing moisture properties of self-levelling flooring compounds and methods used to measure them.

Paper I

Moisture Properties of Self-levelling Flooring Compounds. Part I. Diffusion Coefficients

This submitted paper describes measurements of moisture transport with the cup method. Measurements have been made on three commercially available self-levelling flooring compounds (SLC) with different properties, one normal SLC for non-industrial application, one rapid drying SLC for non-industrial applications and one SLC for industrial floors. The evaluation is based on Fick's first law of diffusion:

$$q_m = -D_v \frac{dv}{dx}$$

where q_m ($\text{kgm}^{-2}\text{s}^{-1}$) is the flux, D_v ($\text{m}^2 \text{s}^{-1}$) is the diffusion coefficient and dv is the difference in water vapour content (kgm^{-3}) over the distance dx (m). Five different internal and one external climate was used in the measurements. By modifying Fick's law it was possible not only to evaluate the mean diffusion coefficient in the vapour content intervals measured, but also in intervals not directly measured. Thereby, the diffusion coefficient could be determined as a function of the vapour content (RH).

Comparing the results from these measurements with similar measurements performed on concrete show that the SLC for non-industrial applications have higher diffusion coefficients at lower vapour contents. This may partly be explained by the larger amount of paste these SLC. At higher RH, diffusion coefficients for concrete are

significantly higher. This may be an effect of the redispersible polymer in the SLC that forms an interspersed secondary binder system in the hydrated product, which may limit the capillary flow that dominates the moisture transport at high RH.

The influence of different amount of mixing water, temperature and initial moisture content was also investigated. A lower water to binder ratio, a lower temperature and a lower initial moisture content all give lower diffusion coefficients.

Paper II

Moisture Properties of Self-levelling Flooring Compounds. Part II. Sorption Isotherms

In this submitted study, the moisture sorption capacity of the three SLC used for paper I was measured. Measurements were made in a sorption balance (DVS 1000, Surface Measurements Systems, London, UK). A flow of dry nitrogen gas is divided into two gas streams of which one is saturated and the other left dry. By mixing different proportions of the gases, the desired RH can be generated. Stepwise measurements were made for certain RH to give the sorption isotherms. Scanning curves were measured by slowly increasing the relative humidity in the gas.

Results show that there is a clear temperature dependence of the sorption isotherms. An increased temperature results in an increased RH at a constant moisture content. Measurements at 1, 3 and 12 months of age indicates a gradual development of the sorption isotherm with time, although most of the isotherm was developed already after 1 month. Carbonation had no significant influence on the sorption isotherm. Scanning curves indicates that even a minute change in moisture content may result in a significant change in RH when changing sorption mode.

Paper III

Method for simultaneous measurement of sorption isotherm and diffusivity of cementitious materials

In this draft paper a method for simultaneous measurements of sorption isotherm and diffusion coefficient using a sorption balance is presented. Traditional determinations of both sorption isotherms and diffusion coefficients, e.g., with methods using saturated salt solutions is a time consuming work. This method makes it possible to determine both these properties for one cementitious material in less than 2 weeks.

Paper IV

A method for simultaneous measurements of heat of hydration and relative humidity

In this conference paper, isothermal calorimetry was used to study reaction processes in cementitious materials. The thermal power is measured while the test specimen is kept in a closed ampoule. During hydration, water is consumed in the hydration reactions and a pore structure is developed in the material where the remaining water will be physically bound. By measuring heat of hydration and equilibrium RH in the same specimen it is possible to determine the self-desiccation, (measured as equilibrium RH) as a function of time and heat of hydration. As the rate of reaction is dependent on the moisture state in a cement material, it is also possible to evaluate the reaction rate, both as a function of water availability (RH) and amount of mixing water.

Measurement of RH inside an Isothermal calorimeter is very suitable as the temperature is stable. Limitations are the small specimen size and the limited head-space for an RH-probe.

Test measurements were made on two types of cement paste. The results of RH measurements are good at water to cement ratios (w/c) above 0.40, but at lower w/c, large variation could be seen. This could be explained by the fact that the ampoules were found to be not completely vapour tight. We believe that lost vapour in the headspace could not be sufficiently replaced by vapour from the relatively dry and vapour tight low w/c pastes.

Chapter 10

Future investigations

The first part of this project, which have been presented in this report, has been focused on moisture properties of SLC and methods for determining them. In the second part of the project, these results will be used when investigating the function of SLC in a complete floor construction. Focus will be on transport of moisture and hydroxide ions (OH^-) and the consequences of such transport, for example chemical degradation of flooring materials and flooring adhesives. The studies presented here have raised a number of questions of which some are intended to be answered later in this project.

- All measurements presented have been made on fully hydrated specimens. However, when newly casted, the properties of cementitious materials are completely different. Consequently, values from these measurements cannot be used when dealing with fresh SLC. Measurements of surface evaporation, self-desiccation and diffusion into substrates are therefore necessary for a more complete picture of the moisture state of an SLC.
- Preliminary laboratory results have shown that a high percentage of the water in a fresh SLC evaporates during the first hours. It is not known whether this also occurs on a construction site where the drying conditions are less favourable. A field study of the climate when SLC are laid would be of interest.
- As have been mentioned, ettringite may release chemically bound water at low RH. Since ettringite is the main reaction product in SLC, it would be interesting to investigate this further and thereby get a clearer picture of the behaviour of ettringite at low RH.
- An SLC contains a number of admixtures, which may influence the moisture properties of the final product. As commercial recipes are very complex and often secret, it would be convenient to prepare a laboratory recipe with simple and well defined ingredients. This would make it possible to study the influence of the most important admixtures on moisture and ion transport properties.

- The transport and occurrence of ions is important as for example hydroxide ions may cause degradation of polymers in adhesives, sealants, plasticisers etc. Such degradations causes secondary emissions, which have negative influence on the indoor air quality.
- Generally the water activity, or relative humidity, is considered to be the factor best describing the influence of moisture on chemical and biological processes in materials. However, studies have shown that hysteresis effects (moisture content) also influences these processes. It would be of interest to perform a study on the influence of water activity and moisture content on the rate of degradation processes.
- Secondary emissions are suspected to have negative influence on the indoor air quality. Two factors that are believed to be critical for chemical degradation are pH (hydroxide ions) and moisture state: the hydroxide ions may react with other components forming volatile products and moisture acts as a transport and reaction medium for components. The development of a laboratory method to quantify degradations rates as a function of both a_w and pH would be of interest.
- A method, developed by Sjöberg, et al., where a flooring system may be exposed to a controlled RH is described in chapter 8. This method will hopefully be further developed and validated later in this project.

Bibliography

- [1] Jacobsson E. ... *och mödan gav sin lön. Om bostadspolitik och bostadskorporation i Stockholm 1870-1930*. Ekonomisk-historiska institutionen, Stockholms universitet, 1996.
- [2] Qvarsell R. Att leva inomhus - ett historiskt perspektiv. In Stålbom G. and Johansson B., editors, *Människan inomhus Perspektiv på vår tids inneklimat*, pages 13–28. Formas, Stockholm, 2003.
- [3] Thörn K. *En bostad för hemmet. Idéhistoriska studier i bostadsfrågan 1889-1929*. PhD thesis, Umeå universitet, Institutionen för idéhistoria, 1997.
- [4] Møhlhave L. The TVOC concept. In Salthammer T., editor, *In Organic Indoor Air Pollutants Occurrence - Measurement - Evaluation*, pages 305–318. WILEY-VCH, 1999.
- [5] Sarwar G., Corsi R., Allen D., and Weschler C. The significance of secondary organic aerosol formation and growth in buildings: experimental and computational evidence. *Atmospheric Environment*, 37:1365–1381, 2003.
- [6] Stolwijk J. A. J. The "sick building" syndrome. In *Proc. Indoor Air Vol. 1*, pages 23–29, 1984.
- [7] Schultz M. and Salthammer T. Sampling and analysis of aldehydes, phenols and diisocyanates. In Salthammer T., editor, *Indoor Air Pollutants Occurrence - Measurement - Evaluation*, pages 15–30. WILEY-VCH, 1999.
- [8] Samuelsson I. *Erfarenheter från saneringen av Dalen*. SP RAPPORT 1996:08, 1996.
- [9] Ryan C. M. and Morrow L. A. Dysfunctional buildings of dysfunctional people: An examination of the sick building syndrome and allied disorders. *Journal of Consulting and Clinical Psychology*, 60(2):220–224, 1992.
- [10] Hicks J. B. Indoor air quality and health complaints. In Hansen D. J., editor, *The work environment volume three, Indoor health hazards*, pages 3–14. Lewis publishers, 1994.

- [11] Samet J. M. Indoor air pollution: a public health perspective. In *Proc. Indoor Air, Helsinki, vol 1*, pages 3–12, 1993.
- [12] Sundell J. Housing and health a state of the art review. *International Journal for Housing Science and Its Applications*, 25:173–180, 2001.
- [13] Jones J. R. Solving indoor air quality problems. In Hansen D. J., editor, *The work environment, volume three, Indoor health hazards*, pages 115–129. Lewis publishers, 1994.
- [14] Wolkoff P., Clausen P. A., Jensen B., Nielsen G. D., and Wilkins C. K. Are we measuring the relevant indoor pollutants? *Indoor Air*, 7:92–106, 1997.
- [15] Weschler C. J. Ozone in indoor environments: Concentration and chemistry. *Indoor Air*, 10:269–288, 2000.
- [16] Bornehag C-G., Blomquist G., Gyntelberg F., Järveholm B., Malmberg P., Nordvall L., Nielsen A., Pershagen G., and Sundell J. Dampness in building and health. Nordic interdisciplinary review of the scientific evidence on associations between exposure to "dampness" in buildings and health effects (NORDDAMP). *Indoor Air*, 11:72–86, 2001.
- [17] Fennema O. R. Water and ice. In Fennema O. R., editor, *Food Chemistry, Second Edition, Revised and Expanded*, pages 23–67. Marcel Dekker Inc., 1985.
- [18] Wargocki P., Sundell J., Bischof W., Brundrett G., Fanger O. P., Gyntelberg F., Hanssen S. O., Harrison P., Pickering A., Seppänen O., and Wouters P. Ventilation and health in non-industrial environments: report from a european multidisciplinary scientific consensus meeting (EUROVEN). *Indoor Air*, 12:113–128, 2002.
- [19] Fog Nielsen K. *Mould growth on building materials Secondary metabolites, mycotoxines and biomarkers*. PhD thesis, Technical University of Denmark, The Mycology group, Biocentrum-DTU, 2002.
- [20] Gravesen S., Frisvad J. S., and Samson R. A. *Microfungi*. Munksgaard, Viborg a/s, 1994.
- [21] Pasanen A-L. A review: Fungal exposure assessment in indoor environments. *Indoor Air*, 11:87–98, 2001.
- [22] Soine L. The psychology of sick building syndrome. In Hansen D. J., editor, *The work environment, volume three, Indoor health hazards*, pages 131–148. Lewis publishers, 1994.

- [23] Ed. Judy Pearsall The Concise Oxford Dictionary. Emission. Oxford University Press, 2001. Oxford Reference Online, <http://www.oxfordreference.com/>, May 27 2004.
- [24] Brown S. K., Sim M. R., Abrahamson M. J., and Gray C. N. Concentrations of Volatile Organic Compounds in indoor air - a review. *Indoor Air*, 4:123–134, 1994.
- [25] Brown S. K. Occurrence of volatile organic compounds in indoor air. In Salthammer T., editor, *Organic Indoor Air Pollutants Occurrence - Measurement - Evaluation*, pages 171–184. WILEY-VCH, 1999.
- [26] Gustafsson H. and Jonsson B. Trade standards for testing chemical emission from building materials Part 1: Measurements of flooring materials. In *Proc. Indoor Air, Helsinki, vol. 2*, pages 437–442, 1993.
- [27] Gunnarsen L. and Kjaer U. D. Secondary emission. In Salthammer T., editor, *Organic Indoor Air Pollutants Occurrence - Measurement - Evaluation*, pages 251–258. WILEY-VCH, 1999.
- [28] Sjöberg A. *Secondary emissions from concrete floors with bonded flooring materials - effects of alkaline hydrolysis and stored decomposition products*. PhD thesis, Chalmers University of Technology, Department of Building Materials, Göteborg, 2001.
- [29] Gustafsson H. Golvmaterial på olika typer av fuktiga betongunderlag - Översikt och kommentarer till undersökningar med inriktning på kemisk nedbrytning och emission. Technical Report SP RAPPORT 1996:25, Borås, 1996.
- [30] *The indoor book*. AB Svensk Byggtjänst, Stockholm, 1999.
- [31] Gustafsson H. The Field and Laboratory Emission Cell - FLEC. In Salthammer T., editor, *Organic Indoor Air Pollutants Occurrence - Measurement - Evaluation*, pages 143–152. WILEY-VCH, 1999.
- [32] Wensing M. Environmental test chambers. In Salthammer T., editor, *Organic Indoor Air Pollutants Occurrence - Measurement - Evaluation*, pages 129–141. WILEY-VCH, 1999.
- [33] Andersson K., Bakke J. V., Bjorseth O., Bornehag C-G., Clausen G., Honglo J. K., Kjellman M., Kjaergaard S., Levy F., Molhave L., Skerving S., and Sundell J. TVOC and health in non-industrial indoor environments. Report from a nordic scientific meeting at Långholmen in Stockholm, 1996. *Indoor Air*, 7:78–91, 1997.

- [34] Wallace L. A. Volatile organic compounds. In Samet J. M. Spengler J. D., editor, *Indoor air pollution A health perspective*, pages 3–12. The John Hopkins University Press, Baltimore, 1991.
- [35] Hedenblad G. Drying of construction water in concrete Drying times and moisture measurement. Technical report, Swedish Council for Building Research, Stockholm, Sweden, 1997.
- [36] Alexanderson J. Secondary emissions from alkali attack on adhesive and PVC floorings. Technical Report Report TVBM-3115, Lund Institute of Technology, Div. Building Materials, 2004.
- [37] Björk F., Eriksson C-A., Karlsson S., and Khabbaz F. Degradation of components in flooring systems in humid and alkaline environments. *Construction and Building Materials*, 17:213–221, 2003.
- [38] GBR Golvbranschens riksorganisation. Mätning av emissionsegenskaper hos sammansatta golvkonstruktioner. Technical report, Golvbranschens riksorganisation, Stockholm, dec. 1999.
- [39] Taylor H. F. W. *Cement chemistry, second edition*. Thomas Telford, London, 1997.
- [40] Powers T. C. Physical properties of cement paste. In *Proceedings of the Fourth International Symposium on the Chemistry of Cement*, Washington D.C., 1962.
- [41] Scrivener K. L. Properties, applications and practicalities of special cements. In *Proc. of the 11th International Congress on the Chemistry of Cement (ICCC)*, pages 84–93, Durban, South Africa, 2003.
- [42] Scrivener K. L. Historical and present day applications of calcium aluminate cements. In *Proc. International Conference on Calcium Aluminate Cements*, pages 3–23, Edinburgh, Scotland, 2001.
- [43] Ericsson H. and Hellström B. Skador i golv på underlag av flytspacklad betong under tiden 1977-1983. *Bygg & teknik*, 3:18–25, 1985.
- [44] Alexanderson J. Floor levelling compounds and the indoor environment. In *International symposium on INNOVATIONS IN MANAGEMENT, MAINTENANCE & MODERNISATION OF BUILDINGS*, Rotterdam, 1992.
- [45] Saarela K. Emission from floor coverings. In Salthammer T., editor, *Indoor Air Pollutants Occurrence - Measurement - Evaluation*, pages 185–202. WILEY-VCH, 1999.

- [46] Hoffman A. Effect of redispersible powders on the properties of self-levelling compounds. Technical paper, Wacker Polymer Systems.
- [47] Harbron R. A general description of flow-applied floor screeds-an important application for complex formulations based on CAC. In *Proc. International Conference on Calcium Aluminate Cements*, pages 597–604, Edinburgh, Scotland, 2001.
- [48] Scrivener K. L., Rettel A., Beal T., and Bier T. Effect of CO₂ and humidity on the mechanical properties of a formulated product containing calcium aluminate cement. In *Proc. Ibaasil vol. 1*, pages 745–752, Weimar, Germany, 1997.
- [49] Encyclopædia Britannica. 2004. *water activity*. Encyclopædia Britannica Online, <http://search.eb.com/eb/article?eu=120847>, September 13 2004.
- [50] Ed. Ailsa Allaby The Concise Oxford Dictionary and Michael Allaby. Relative humidity. Oxford University Press, 1999. Oxford Reference Online, <http://www.oxfordreference.com/views/ENTRY.html?subview=Main&entry=t13.e7087>, September 14 2004.
- [51] Iglesias H. A. and Chirife J. *Handbook of food isotherms : Water Sorption Parameters for Food and Food Components*. Academic Press, New York, 1982.
- [52] Adamson A. W. *Physical Chemistry of Surfaces, 5th edition*. John Wiley & Sons, Inc., 1990.
- [53] Labuza T. P., Cassil S., and Sinskey A. J. Stability of intermediate moisture foods. 2. Microbiology. *Journal of food science*, 37:160–162, 1972.
- [54] Bažant Z. P and Najjar L. J. Nonlinear water diffusion in nonsaturated concrete. *Materials and Structures*, 5, No 25:3–20, 1972.
- [55] L-O. Nilsson. Temperature effects in relative humidity measurements on concrete - some preliminary results. In *Building physics in the Nordic countries*, pages 456–462, Lund, Sweden, 1987.
- [56] Jones L. and Atkins P. *Chemistry Molecules Matter and Change, 4th edition*. W. H. Freeman and Company, New York, 2002.
- [57] Yunping X., Bažant Z. P., Molina L., and Jennings H. M. Moisture diffusion in cementitious materials Moisture capacity and diffusivity. *Advanced Cement Based Materials*, 1:258–266, 1994.
- [58] Shimida Y. and Young J.F. Structural changes during thermal dehydration of ettringite. *Advances in cement research*, 13:77–81, 2001.

- [59] Zhang L. and Glasser F. P. Critical examination of drying damage to cement pastes. *Advances in cement research*, 12:79–88, 2000.
- [60] Encyclopædia Britannica. 2004. *alkali*. Encyclopædia Britannica Online, <http://search.eb.com/eb/article?eu=5826>, July 28 2004.
- [61] Rombén L. Kemiskt angrepp. In *Betonghandbok Material, utgåva 2*, pages 809–847. AB Svensk byggtjänst, Solna, Sweden, 1994.
- [62] Björk F. and Eriksson C. A. Measurement of alkalinity in concrete by a simple procedure, to investigate transport of alkaline material from the concrete slab to a self-levelling screed. *Construction and Building Materials*, 16:535–542, 2002.
- [63] Byfors K. and Tuutti K. Armeringskorrosion. In Ljungkrantz C., Möller G., and Petersons N., editors, *Betonghandbok Material, utgåva 2*, pages 785–808. AB Svensk Byggtjänst, Solna, Sweden, 1994.
- [64] Talu M. and Özgün H.B. Alkaline hydrolysis of poly(ethyl acrylate) and styrene-ethyl acrylate copolymer. *Eur. Polym. J.*, 26:5–7, 1990.
- [65] Sjöberg A. *Transportprocesser och reaktioner i belagda betonggolv - olika faktorerers inverkan på emission från golvkonstruktioner*. Report P-98:13, Department of Building Materials, Chalmers University of Technology Göteborg, 1998.
- [66] Sjöberg A. and Anderberg A. Förbättrad mätmetod för limmade golvkonstruktioner. *Bygg & teknik*, 5, aug.:62–63, 2003.

The included papers

Paper I

Moisture in Self-levelling Flooring Compounds. Part I. Water Vapour Diffusion Coefficients

Anders Anderberg
M.Sc., Dr.-student
Div. Building Materials, Lund University
P.O. Box 118, 221 00 Lund, Sweden
E-mail: anders.anderberg@byggtek.lth.se

Lars Wadsö
Dr., Senior researcher
Div. Building Materials, Lund University
P.O. Box 118, 221 00 Lund, Sweden
E-mail: lars.wadso@byggtek.lth.se

ABSTRACT

Diffusion coefficients of three self-levelling flooring compounds (SLC) and water vapour resistance of a primer have been measured with the cup method. The results show that the diffusion coefficient is dependent not only on the vapour content (relative humidity), but also on the absolute moisture content, i.e., there is a hysteresis effect on moisture transport. SLC have higher diffusion at RH lower than approximately 90% than normal concrete, but the opposite is true at higher RH. The latter can be an effect of the high amount of redispersible polymer powder in SLC that form a film throughout the material and thereby limits capillary moisture transport.

Key words: moisture transport, water vapour, self-levelling flooring compound, cup method, diffusion coefficient.

1. INTRODUCTION

During the last decades there has been an increasing interest in the possible connections between indoor air quality and health, and it has been found that dampness is a risk factor for health effects in the airways, tiredness and headache [1]. This seems to be true irrespectively of if the dampness is measured as condensation on windowpanes, water damage or smell/odour. However, it is not known what the connection between dampness and health effects is. Two discussed possibilities are emissions from degraded building materials and emissions from microbial growth. Both chemical degradation processes and microbial growth increase with increasing moisture content as the molecular mobility of chemical reactants and microbial nutrients then increases [2].

Cementitious materials are often considered to contribute to healthy indoor environments, as they are stable inorganic materials. However, their very alkaline nature can give rise to problems as many other modern building materials, like adhesives, sealants, flooring materials and paints,

are based on polymers, some of which are not stable under alkaline conditions. A common problem in Sweden is PVC flooring bonded to concrete floors with a water-based adhesive. As long as the concrete is dry the construction works well, but if the moisture level increases the alkaline pore solution will come in contact with the adhesive, possibly degrading it by hydrolysis [3]. The degradation products are often strongly odorous alcohols like 2-ethylhexanol and butanol that diffuse through the PVC flooring into the indoor environment.

The above-mentioned problems can occur in older buildings if the moisture level in a concrete floor increases, for example because of leakage. It can also occur in new buildings if the concrete has not been dried enough before flooring materials are laid. Different solutions have been proposed to make it possible to build the above type of constructions without risk of degradation:

- The use of alkali resistant polymers in adhesives.
- The placement of a thin low-alkali flooring compound between the concrete and the adhesive.
- The use of self-desiccating concrete.

These solutions and combinations of them have been tested with good results, both in laboratories and in buildings [3-6].

Self-levelling flooring compounds (SLC) are normally laid in 1-30 mm layers on concrete or other substrates to give a horizontal and smooth surface for flooring materials. When used on concrete they may also act as a barrier to alkalis between the concrete and the flooring, thus giving the flooring and adhesive a less aggressive environment. Usually a polymer primer is applied on the substrate before the SLC is laid. The primer gives a better and more uniform bonding between substrate and SLC, prevents air from the concrete to give rise to bubbles on the SLC surface and also prevents excessive amounts of water from the fresh SLC to be absorbed by the substrate.

This paper reports a study of water vapour diffusion coefficients of three commercial SLC measured with the cup method. Although several workers have measured diffusion coefficients of concrete and mortars, we know of only one previous study on a flooring compound (non self-levelling) [7]. The present study, together with measurements of sorption isotherms and scanning curves [8], can be used to predict the moisture state of flooring constructions. This is of interest, e.g., for prediction of:

- The long-term moisture state of the flooring adhesive.
- The distribution of the water from a water based adhesive applied on an SLC.
- The transport of hydroxide ions (OH^-) from the usually more alkaline concrete to the flooring adhesive and other sensitive materials.

SLC consist of binder, filling materials, polymers and admixtures. The binders are normally a mixture of calcium aluminate cement (CAC), Portland cement (PC) and calcium sulphate in the forms of anhydrite and hemihydrate. Filling materials are sand and finely ground mineral materials like lime stone. A polymer powder is added to improve abrasion resistance and the flexural and tensile strength of the otherwise brittle cement matrix. The polymer particles coalesce and form a film [9] that can be described as an interspersed secondary binder system [10]. The admixtures control, e.g., setting time, curing time, flowing characteristics, air entrainment and separation. A more detailed description of SLC is given by Harbron [10].

The moisture state of a material can be represented in different ways. In this paper we have chosen to work with vapour content v (g vapour per m³ air). This can be seen as the vapour state of the pores of the material and is convenient because this potential can also be used for the gas phase in which we generate the moisture states. The vapour content is the product of the relative humidity (expressed as a fraction) and the saturation vapour content, which can be found tabulated as a function of temperature.

Moisture can be transported by vapour diffusion, surface flow and capillary flow. Since it normally is of no interest separate the effects of different kinds of transport processes, the total moisture flow is usually determined. The moisture transport properties of a material are then described with one coefficient, the diffusion coefficient D . For most materials the diffusion coefficient is a function of the vapour content (or, at isothermal conditions, the relative humidity, RH).

2. MATERIALS AND METHOD

2.1 Materials

The three tested commercial products were based on Portland cement, calcium aluminate cement, calcium sulphate and small amounts of silica fume. A typical composition of the mineral part of an SLC is shown in Table 1.

Table 1 – Typical composition of the mineral part (excluding admixtures) of an SLC [11].

Portland cement	less than 3%
Calcium aluminate cement	around 17%
Calcium sulphate	around 7%
Limestone filler (calcite)	around 30%
Sand (siliceous)	45-50%

The three tested products were:

- A. Normal SLC with a water to binder ratio of about 1.0. This product is generally used in non-industrial constructions.
- B. Rapid-drying SLC, which is similar to the above product, but is used with a lower water to binder ratio (about 0.7) to give the product a higher degree of self-desiccation. This product is mainly used in renovation as it allows foot traffic in 1-2 hours and final covering in 1 day.
- C. SLC for industrial floors, containing slag as a binder and a larger amount of polymer to increase the abrasion resistance [9]. The water to binder ratio was about 0.6. The product allows medium heavy rolling equipment.

The products were mixed according to the manufacturers guidelines and left to hydrate, the first 24 hours in open air, approximately 20 °C and 50% RH, and after that in sealed plastic bags. Measurements were made when the specimens were 2-6 months old, except the dried and wetted specimens for hysteresis measurements that were 8-11 months old.

Influence of the amount of mixing water was tested in flooring compound A by using 10% more and 20% less mixing water than required by the manufacturer's guideline. The effects of hysteresis on the diffusion coefficient due to desorption or absorption was also tested by drying and wetting test specimens of flooring compound A before testing. These dried and wetted specimens had been used in the main measurement series. While still attached to the cups, they were either dried at 25% RH and 30 °C, or wetted with liquid water.

The diffusion resistance of a primer was measured by applying it on test specimens of product A. The primer was a dispersion consisting of styrene acrylate in water. The fraction of styrene acrylate used in the dispersion depends on the substrate. In these tests the primer contained about 12% styrene acrylate.

2.2 Cup method

The cup method was used to determine diffusion coefficients. In this method two different constant humidity levels are created at each side of a test specimen. Normally the specimen is placed as a lid on a cup containing a saturated salt-solution. The internal RH is controlled by the salt solution and the external RH is that of the room where the cup is placed. The mass flow rate is measured by weighing the cup regularly, thus registering the weight change of the cup.

Fick's law of diffusion is:

$$q = -D \frac{dv}{dx} \quad (1)$$

where q (g/(m²s)) is the moisture flow, D (m²/s) the diffusion coefficient and dv (g/m³) the difference in vapour content over the distance dx (m). An integrated form of Fick's law can then be used to calculate the diffusion coefficient:

$$q = \bar{D} \frac{v_2 - v_1}{L} \quad (2)$$

Here, \bar{D} (m²/s) is the average diffusion coefficient in the interval v_1 to v_2 and L (m) is the thickness of the specimen. A complication for a cup measurement is that the measured flow rate is not only a function of the diffusion resistance within the material, but also depends on external mass transfer resistances at both sides of the specimen, Z_i and Z_e (s/m). Inside the cup Z_i is normally equal to the diffusion resistance of the stagnant air in the gap between the salt solution and the specimen. Outside the cup, where there always are air movements, Z_e is a boundary layer mass transfer resistance. The total flow can thus be described as follows:

$$q = \frac{1}{L/\bar{D} + Z_i + Z_e} (v_2 - v_1) \quad (3)$$

The diffusion cups (Fig. 1) used in this study, were designed and previously used by Hedenblad [12]. The cups were made of polypropylene and the sealing was made with a polyurethane sealant (Marine Adhesive Sealant 5200, 3M, St Paul MI, USA). The tightness of the cups was

validated with aluminium specimens. The leakage was 0.5 mg per day over a 300-day period with an internal RH of 100% and an external RH of 55% at 20 °C. This leakage corresponds to less than 1% of the moisture flow in all present measurements.

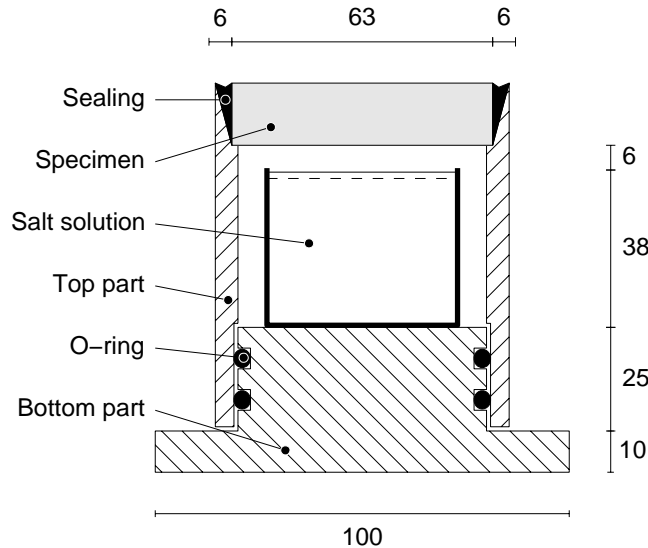

Figure 1– Schematic picture of the cup used. Different top parts have different heights of the bevelled part to fit specimens with different thickness.

The experiments were carried out with focus on higher RH, as this is the most interesting area related to indoor environment. The diffusion coefficients were mainly determined at 20 ± 1 °C with an outer climate of $55 \pm 2\%$ RH. The RH inside the cups were as follows [13]:

75.5% (NaCl)	85.1% (KCl)	94.6% (KNO ₃)
97.6% (K ₂ SO ₄)	100% (H ₂ O)	

Tests were also performed at 5 ± 1 °C in a climate box. The outer climate had an RH of 63.5%, (NaBr) and the RH inside the cups were as follows [13]:

75.6% (NaCl)	87.7% (KCl)	96.3% (KNO ₃)
98.5% (K ₂ SO ₄)	100% (H ₂ O)	

Measurements were started with specimens standing in a climate room with low air velocity, approx. 0.05 m/s. To minimise the influence of the external mass transfer resistances, the air velocity above the specimens was increased with a fan to about 2 m/s. This gave a slightly higher flow rate for specimens with the highest diffusion rate, but did not influence the results of the other specimens.

All tests were performed with triple or quadruple specimens of 8 ± 1 mm thickness and 63 ± 1 mm diameter. Individually measured values of thickness and diameter were used in the evaluation. An analytical method [14] for correction of edge effects has been used in these evaluations, as the moisture flow is not perfectly one-dimensional at the edges of our specimens.

3. EVALUATION

The isothermal cup measurements have been made with one external climate and five different internal climates. The aim of the evaluation is to calculate the diffusion coefficient as a function of the moisture state. As discussed above, there are both internal and external mass transfer resistances in the cups. We have assumed that the internal mass transfer resistance, Z_i , is equal to the resistance of stagnant air in the air gap between the salt solution and the specimen and that the external mass transfer resistance is negligible. Zero external resistance, Z_e , was used as it was found that the mass transfer rates for the cups with low flow rates were independent of the external air velocity. The cups with high mass flow rates were all measured with 2 m/s air velocity above the specimens. In the present evaluations the vapour content at the internal side of the specimen was calculated as the vapour content of the salt solution minus the vapour content difference over the air gap. The external vapour content used was that of the ambient climate. Constant condition on one side of the specimen is a prerequisite for the evaluation method outlined below.

Equation 2 can be rewritten:

$$qL = \bar{D}(v_2 - v_1) \quad (4)$$

All cup measurements of a certain material and in a certain vapour content range will have the same product of mass flow rate and specimen thickness. Rewriting Eq. 1 and integrating gives:

$$\int_0^L q dx = - \int_{v_1}^{v_2} D(v) dv \quad (5)$$

The left hand side integral is qL (Eq. 4). Therefore:

$$\bar{D} = \frac{\int_{v_1}^{v_2} D(v) dv}{v_2 - v_1} \quad (6)$$

If two cup measurements are made with the same external climate v_0 , but with two different internal climates v_1 and v_2 , it is possible to calculate the mean diffusion coefficients in two intervals: D_{01} and D_{02} . Here, Eq. 4 is written for these two measurements and for a hypothetical measurement in the interval v_1 to v_2 , see Fig. 2:

$$q_m L_a = \bar{D}_{02}(v_2 - v_0) \quad (7)$$

$$q_m L_b = \bar{D}_{01}(v_1 - v_0) \quad (8)$$

$$q_m L_c = \bar{D}_{12}(v_2 - v_1) \quad (9)$$

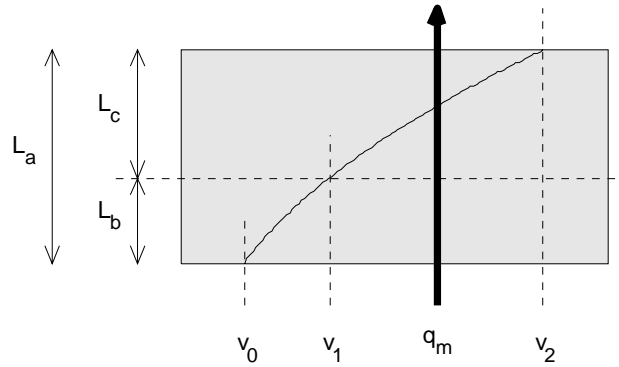

Figure 2 – A schematic drawing of a cup measurement made with a specimen of thickness L_a between vapour contents v_0 and v_2 . Also shown is the division of the specimen into two specimens of thickness L_b and L_c and how one will get the same flow as with the thicker specimen by making measurements in the interval v_0 to v_1 and v_1 to v_2 , respectively.

Note that these three measurements have the same flow rate and that $L_a=L_b+L_c$. From Eqs. 7-9 one can write the following expression for D_{12} :

$$\bar{D}_{12} = \frac{\bar{D}_{02}(v_2 - v_0) - \bar{D}_{01}(v_1 - v_0)}{v_2 - v_1} \quad (10)$$

As this equation does not include q or L , it is a general expression valid also for specimens that do not conform to the limitations of Fig. 2 (same q and $L_a=L_b+L_c$). Equation 10 can thus be used to calculate mean diffusion coefficients in difference-intervals not directly measured.

Measurements were made with one external climate v_0 and five different internal climates v_1-v_5 . $D_{01}, D_{02}... D_{05}$ can directly be calculated with Eq. 4 and $D_{12},... D_{45}$ can be calculated with Eq. 10, i.e., the diffusion coefficient is obtained as a function of the moisture state. Other similar methods for evaluation have been proposed, e.g., by Chang et al. [15] and Bažant et al. [16].

4. RESULTS AND DISCUSSION

4.1 Diffusion coefficients

The results are presented in Figs. 3-5. As can be seen in Figs. 3 and 4, the rapid drying SLC B with lower water to binder ratio has a slightly lower diffusion coefficient than SLC A. When compared with concrete [7, 17] SLC A and B both have higher diffusion coefficients up to about 90% RH. This can be explained by the higher aggregate content of concrete. At higher RH, diffusion coefficients for concrete are significantly higher. This may be an effect of the redispersible polymer in the SLC that forms an interspersed secondary binder system in the hydrated product, which may limit the capillary flow that dominates the moisture transport at high RH. The influence from the transition zone between aggregate and paste may also differ between concrete and SLC.

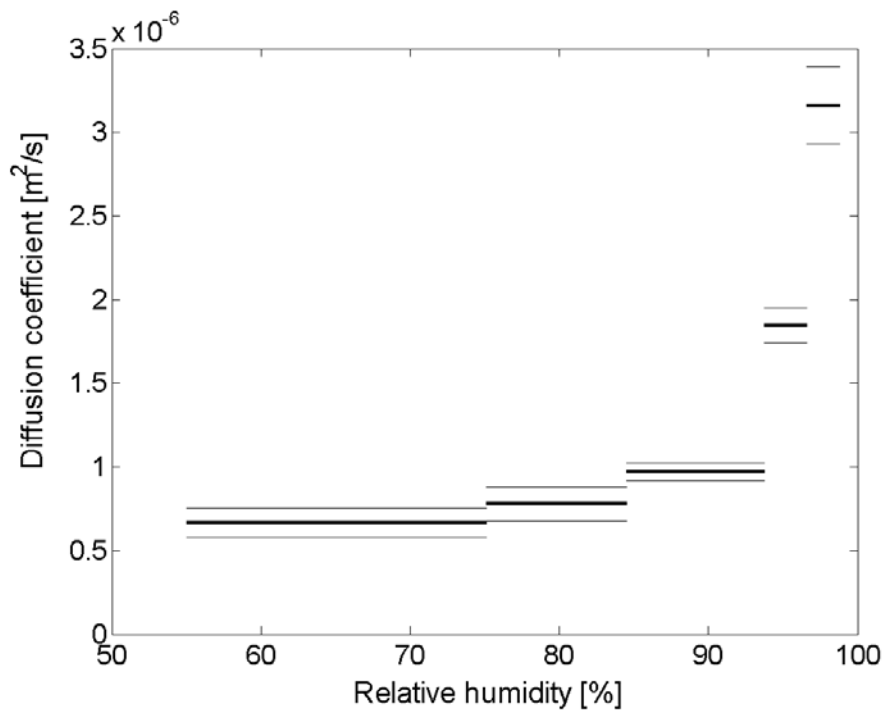

Figure 3 – Diffusion coefficient for SLC A. Thick line is the mean value in the shown interval. Thin lines indicate one standard deviation.

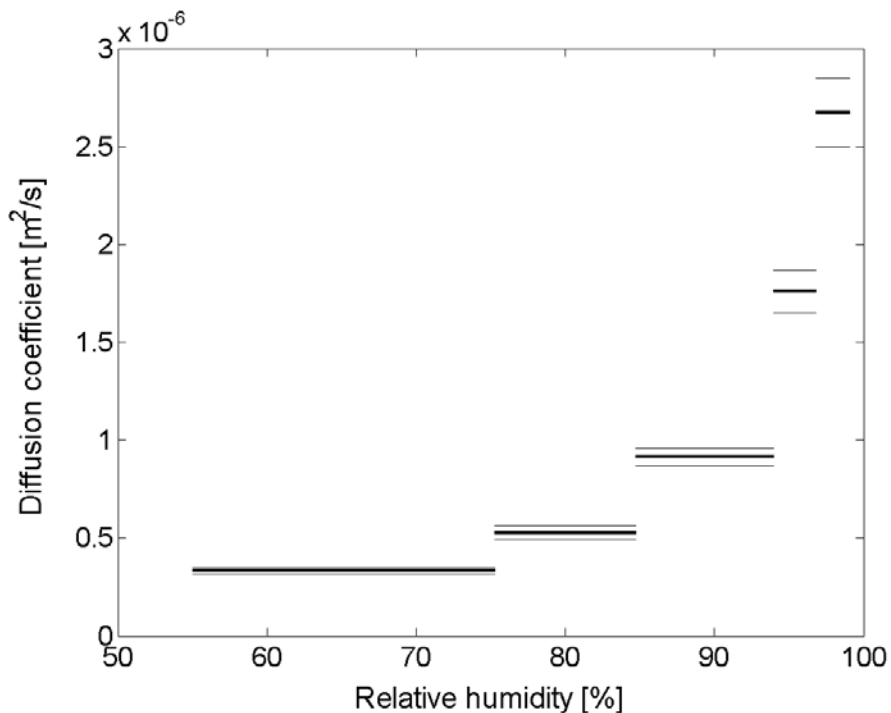

Figure 4 – Diffusion coefficient for SLC B. Thick line is the mean value in the shown interval. Thin lines indicate one standard deviation.

SLC C (Fig. 5) for industrial floors has a lower diffusion coefficient than the other two SLC. This may be an effect of the higher polymer content in the industrial flooring material, the lower

water to binder ratio and the slag content. Although microstructures of slag cement pastes are similar to those of Portland cement, the permeability is normally lower in slag cement pastes [18].

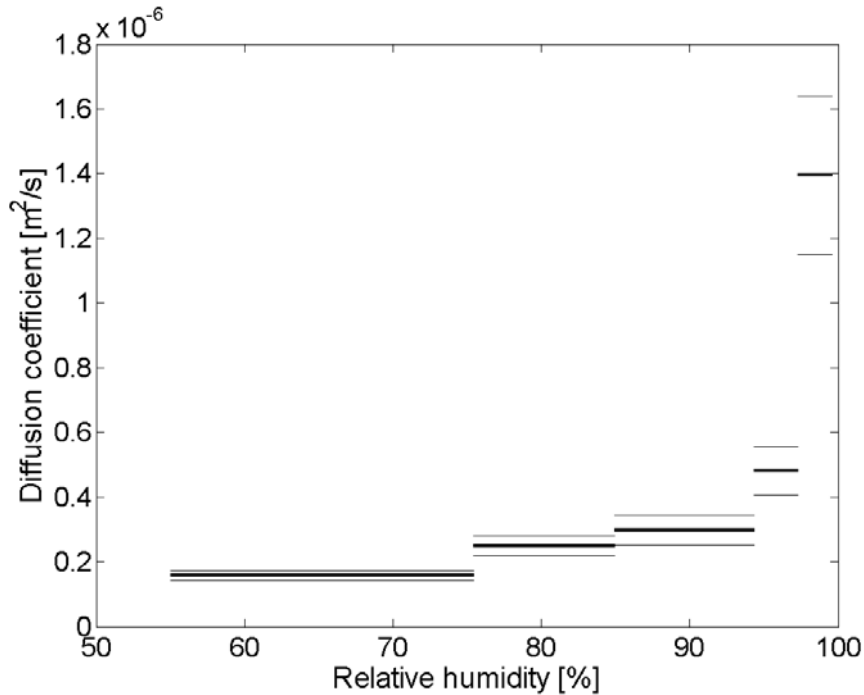

Figure 5 – Diffusion coefficient for SLC C. Thick line is the mean value in the shown interval. Thin lines indicate one standard deviation.

4.2 Influence of water/binder ratio

As can be seen in Table 2, the diffusion increases with increasing water to binder ratio.

Table 2 – Mean diffusion coefficients and standard deviations for samples of product A made with different amounts of mixing water. Four specimens were measured in each sample.

Sample	RH-interval %	Diffusion coefficient $10^{-6} \text{ m}^2/\text{s}$
Normal	55-85.1	0.70 ± 0.02
	55-97.6	0.84 ± 0.03
+ 10% mixing water	55-85.1	0.85 ± 0.03
	55-97.6	0.93 ± 0.02
- 20% mixing water	55-85.1	0.47 ± 0.03
	55-97.6	0.59 ± 0.03

4.3 Influence of hysteresis

Most materials have sorption hysteresis as they have different isotherms for desorption (drying) and absorption (humidification). At a certain RH a drying specimen contains more water than a specimen absorbing water vapour. The influence of this on the diffusion rate has been studied by measurements of diffusion coefficients with specimens in absorption and desorption mode, respectively, Table 3. The results indicate that specimens undergoing desorption, i.e., contains more water, have higher diffusion coefficients.

Table 3 – Mean diffusion coefficients and standard deviations for samples of product A in absorption and desorption mode. Each sample contained three specimens. Note that these test specimens were older than the other test specimens and the results can therefore not directly be compared with the other results in this article.

Sample (Product A)	RH-interval %	Diffusion coefficient $10^{-6} \text{ m}^2/\text{s}$
Absorption	55-75.5	0.59 ± 0.05
Desorption	55-75.5	0.78 ± 0.01
Absorption	55-97.6	0.71 ± 0.05
Desorption	55-97.6	0.90 ± 0.05

4.4 Influence of temperature

A direct comparison between measurements at 20 and 5 °C was not possible to make, as the saturated salt solutions used do not generate the same RH at different temperatures. An estimation is however possible to make and this shows that the diffusion coefficient at 5 °C is about 60% of the diffusion coefficient at 20 °C, see Table 4.

Table 4 – Mean diffusion coefficients and standard deviations at 20 and 5 °C for product A. Samples measured at 20 °C contained four specimens and samples measured at 5 °C contained three specimens.

Temperature °C	RH-interval %	Diffusion coefficient $10^{-6} \text{ m}^2/\text{s}$
20	55-75.5	0.67 ± 0.09
20	55-94.6	0.77 ± 0.04
20	75.5-94.6	0.97 ± 0.13
5	63.5-75.6	0.40 ± 0.07
5	63.5-96.3	0.47 ± 0.05
5	75.6-96.3	0.58 ± 0.11

4.5 Influence of polymer primer

Results of measurements with and without primer (not given here) show that the resistance of the primer was in the order of 5000 s/m at 75% RH. The amount of applied primer was 0.4 kg

solution per m^2 , i.e., $0.05 \text{ kg (solid)/m}^2$. A dependence of thickness could also be seen, where an increased amount of primer applied gave a higher resistance.

4.6 General discussion

The only reference found with measurements of diffusion coefficients of a flooring compound was Hedenblad [7]. His results are in fair agreement with our measurements. However, the flooring compound used by Hedenblad did not have self-levelling properties and was probably of a different composition than the SLC in this investigation.

A survey of sources of uncertainty and errors in the cup method was done by Hansen and Lund [19]. The main sources of uncertainty described were surface and air space resistances, changes in barometric pressures, RH oscillations and boundary effects. In the present study, long-term measurements minimised the influence of barometric pressure changes and RH oscillations. Surface and air space resistances and boundary effects are described earlier in this paper.

When evaluating diffusion coefficients with Eq. 10, values from measurements are used both when evaluating diffusion coefficients in the measured interval and in the next interval with higher RH. This means that measurement errors in one interval also influence the calculated diffusion coefficients of the next higher interval and that the uncertainty for these calculated values increases. This can be seen in Table 4, where the last diffusion coefficients are calculated from the first two values.

Carbonation occurs in all cement-based materials. Carbonation in ettringite systems [20] and calcium aluminate cement [21] leads to a slightly more open material. Consequently, materials exposed to air should have higher diffusion coefficients than less carbonated materials. Materials in these experiments were hydrated in sealed plastic bags, but exposed to air when measurements were performed.

Evaluation of measurements with Eq. 10 requires that the material is homogeneous. Carbonation as, discussed above, can give the material slightly different properties, as the carbonation front moves from the surface and inwards into the specimen. There may also be a higher concentration of redispersible polymer in the surface region as a consequence of bleeding in the fresh mortar. Water transported from the fresh mortar to the surface may carry polymers, which then accumulates in the surface region, while the water evaporates. This higher concentration of polymers in the surface may influence the moisture transport properties and therefore give a slightly inhomogeneous material.

Measurements of moisture transport properties together with measurements of moisture storage capacities (sorption isotherms) [8] makes it possible to calculate and predict drying times, moisture loads, ion transport etc. This is important because it is well known that other materials may take harm in contact with cementitious materials under high moisture loads.

5. ACKNOWLEDGEMENTS

We thank Bo Johansson for helping us with the measurements.

REFERENCES

1. Bornehag, C.-G., et al., "Dampness in Building and Health Nordic Interdisciplinary Review of the Scientific Evidence on Associations between Exposure to "Dampness" in Buildings and Health Effects (NORDDAMP)." *Indoor Air*, Vol. 11, 2001, pp. 72-86.
2. Fennema, O.R., "Water and Ice", in *Food Chemistry*, O.R. Fennema, Editor. 1985, Marcel Dekker Inc. New York and Basel. pp. 23-67.
3. Sjöberg, A., "Secondary emissions from concrete floors with bonded flooring materials - effects of alkaline hydrolysis and stored decomposition products" P-01:2, Department of Building Materials. Chalmers University of Technology: Göteborg. 2001, 188 pp.
4. Wengholt Johnsson, H., "Flooring materials on concrete substrate - Field measurement of drying times and emissions in Gärdsrådet, Umeå (In Swedish)". NCC Teknik Göteborg. 1998, 27 pp.
5. Björk, F., et al., "Degradation of Components in Flooring Systems in Humid and Alkaline Environments." *Construction and Building Materials*, Vol. 17, 2003, pp. 213-221.
6. Alexanderson, J., "Emissions from alkali attack on adhesives and floor coverings." *Concrete*, Vol., 2001, pp. 18-19.
7. Hedenblad, G., "Material data for moisture transport calculations (In Swedish)". Byggforskningsrådet: Stockholm. 1996, 53 pp.
8. Anderberg, A. and Wadsö, L., "Moisture in Self-levelling Flooring Compounds. Part II. Sorption Isotherms." *Submitted*
9. Hoffman, A., "Effect of Redispersible Powders on the Properties of Self-Levelling Compounds". Technical paper, Wacker Polymer Systems, 20 pp.
10. Harbron, R. "A General Description of Flow-Applied Floor Screeds-An Important Application for Complex Formulations Based on CAC". *Proceedings*, International Conference on Calcium Aluminate Cements. Edinburgh, Scotland 2001. pp. 597-604.
11. Scrivener, K.L., et al. "Effect of CO₂ and humidity on the Mechanical Properties of a Formulated Product Containing Calcium Aluminate Cement". *Proceedings*, Ibausil. Weimar, Germany 1997, vol. 1. pp. 745-752.
12. Hedenblad, G., "Moisture permeability of some porous materials". *Report TVBM-7068*, Building Materials, Lund Technical University. 1993, 5 pp.
13. Greenspan, L., "Humidity Fixed Points of Binary Saturated Aqueous Solutions." *Journal of Research of the National bureau of Standards-A. Physics and Chemistry*, Vol. 81A, No. 1, 1976, pp. 89-96.
14. Claesson, J., Hagentoft, C.-E., and Wadsö, L., "Masked Edge Effects When Measureing Diffusion Coefficients With the Cup Method." *Polymer Engineering and Science*, Vol. 34, 1994, pp. 821-826.
15. Chang, S.C. and Hutcheon, N.B., "Dependence of Water Vapor Permeability on Temperature and Humidity". 1956, Trans. ASHRAE, 62. p. 437-450.
16. Bažant, Z.P. and Najjar, L.J., "Nonlinear water diffusion in nonsaturated concrete." *Materials and Structures*, Vol. 5No 25, 1972, pp. 3-20.

17. Nilsson, L.-O., "Long-term moisture transport in high performance concrete." *Materials and Structures*, Vol. 35, 2002, pp. 641-649.
18. Taylor, H.F.W., "Cement Chemistry". 2nd edition. Thomas Telford, London, 1997, 437 pp.
19. Kielsgaard Hansen, K. and Lund, H.B. "*Cup method for determination of water vapour transmission properties of building materials. Sources of uncertainty in the method*". *Proceedings*, Proceedings of the 2nd symposium "Building Physics in the Nordic Countries" 1990. pp. 291-298.
20. Scrivener, K.L. "*Historical and Present Day Applications of Calcium Aluminate Cements*". *Proceedings*, International Conference on Calcium Aluminate Cements. Edinburgh, Scotland 2001. pp. 3-23.
21. Gaztañaga, M.T., Gonñi, S., and Guerrero, A. "*Accelerated Carbonation of Calcium Aluminate Cement Paste*". *Proceedings*, Calcium Aluminate Cements. Edinburgh, Scotland 2001. pp. 349-358.

Paper II

Moisture in Self-levelling Flooring Compounds. Part II. Sorption Isotherms

Anders Anderberg
M.Sc., Dr.-student
Div. Building Materials, Lund University
P.O. Box 118, 221 00 Lund, Sweden
E-mail: anders.anderberg@byggtek.lth.se

Lars Wadsö
Dr., Senior researcher
Div. Building Materials, Lund University
P.O. Box 118, 221 00 Lund, Sweden
E-mail: lars.wadso@byggtek.lth.se

ABSTRACT

Moisture sorption in self-levelling flooring compounds was investigated by using a sorption balance. Results are presented as sorption isotherms. Influence of temperature, age, water to binder ratio and carbonation are also presented. An increased temperature and increased water to binder ratio gives lower moisture sorption. Results from scanning curves indicate that, when changing sorption mode, even a minute change in moisture content may result in a significant change in relative humidity in the material.

Key words: sorption isotherm, water vapour, self-levelling flooring compound, sorption balance.

1. INTRODUCTION

Recently, the connection between the indoor environment and occupants health has gained an increased interest. Moisture has been shown to be an important factor as it promotes chemical reactions and biological growth. This is further discussed in the first paper [1] of this series of two papers dealing with moisture properties of self levelling flooring compounds.

Moisture in materials has different properties and is of different interest depending on how hard the water molecules are bound to the surface and the structure of the material. This is important as not all water inside materials contribute to the processes that may influence the indoor environment. The weakest bound water is here the most interesting as it supports biological growth, transport of substances, etc. [2].

The strongest bound water in a cementitious material is chemically bound as reaction products in the hardened cement paste and is part of the solid structure of the material. As this water is strongly bound in the structure and does not leave the material under normal circumstances it is of no interest concerning indoor environmental aspects.

Physically bound water stands in equilibrium with the water vapour in the surrounding atmosphere. The amount of water in a material, excluding chemically bound water, is normally given as a sorption isotherm, i.e., the relation between the moisture content (the mass of water per mass of dry material) and the relative humidity (RH) at equilibrium.

Physically bound water can either be adsorbed to surfaces, absorbed in the structure of the material or capillary condensed on water menisci formed in pores. The first layer of adsorbed water is the strongest bound, most immobile and unfreezable at $-40\text{ }^{\circ}\text{C}$ [2]. This water behaves as part of the solid and corresponds to the monolayer moisture content. A monolayer can be seen as when all of the dry matter is covered with one layer of water molecules [3]. Further added water is more mobile. When sufficiently abundant this water allows chemical reactions and microbial growth.

In porous materials water is bound not only due to adsorption, but also due to capillary condensation. Water molecules then condense on concave water menisci. Pores with radii less than a certain critical radius are then completely water filled. The curvature of the menisci corresponds to a certain equilibrium RH. A smaller radius corresponds to a lower equilibrium RH. When a material is in equilibrium with low RH, only small water menisci can exist, i.e., only small pores can be completely water filled. At higher RH, larger water menisci can exist and pores with larger pore radii can thus be water filled. In a fine porous material, capillary condensed water is the dominant contributor to transport processes, chemical reactions and microbial growth.

A consequence of capillary condensation is sorption hysteresis [3], i.e., a material will contain different amounts of water in equilibrium with a certain RH, depending on whether the material is drying or taking up moisture, Fig. 1. A material taking up moisture never contains more water than a drying material at the same RH.

As can be seen in Fig. 1, a sorption isotherm contains two main curves, one for desorption and one for absorption. If a previously desorbing material starts to absorb moisture it follows a scanning curve from the desorption isotherm towards the absorption isotherm and vice versa. A result of this is that a small increase in moisture content may lead to a large increase in RH. The consequence of this for moisture related processes is not fully known, but it is probable that RH is not the only parameter describing the rate of chemical and biological processes [2] and that moisture content also may be important, which has been seen for microbial growth on food stuffs [4].

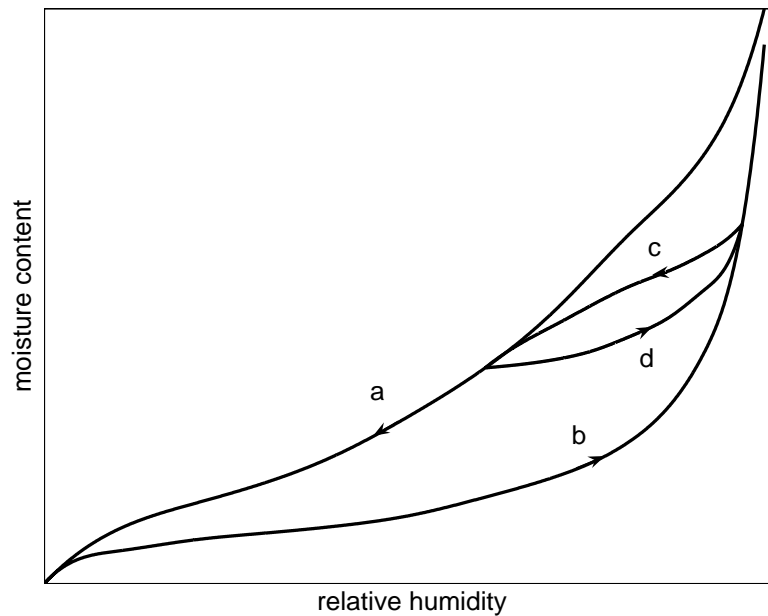

*Figure 1 – Example of a sorption isotherm, where **a** is a desorption isotherm, **b** an absorption isotherm, **c** a scanning curve from the absorption isotherm to the desorption isotherm and **d** a scanning curve from the desorption isotherm to the absorption isotherm.*

The sorption isotherm is, as the name indicates, only valid at a certain temperature. An increase in temperature at constant moisture content results in an increase in RH [2, 5], opposite to the behaviour of air, where an increase in temperature results in lower RH. For concrete, variations of the sorption isotherm within normal temperature ranges are generally neglected, although studies by for example Nilsson [6] show a temperature dependence of about 0-0.4% RH per °C depending on moisture condition. A stronger temperature dependence has been found for some food stuffs, where a temperature increase of 10 °C can result in an increase of up to about 20%-units RH [7]. An increase in temperature normally increases the rate of chemical reactions [8].

Chemical reactions are dependent on transport properties, as reactants have to come in contact with each other. The critical RH limits at which processes start to take place are somewhat diffuse. For example, for indoor storing of steel the critical RH is often considered to be 60%, but practical values for outdoor use has been shown to be more than 80% [9]. A practical value often used in Sweden for concrete slabs with bonded PVC-flooring is 85% RH. Generally an RH of at least 80% is needed for biological growth, although some species can grow at lower RH [2, 10].

This paper deals with physically bound water in the RH-range of 10-95%. Measuring moisture at higher RH levels than 98%, requires other measurement techniques, see e.g. [11-14]. Measuring moisture down to 0% RH gives incorrect values for self-levelling flooring compounds (SLC) as chemically bound water from ettringite is partly non-reversibly released. This has been observed during vacuum drying and drying over desiccants [15] and drying at temperatures above 60 °C [16]. We have noted a significant decrease in mass when drying specimens from 10% to 0% RH (not shown in this paper). This mass decrease corresponded to

more than 5% moisture content, i.e., more than the total sorption capacity between 10% and 95% RH.

2. MATERIALS AND METHOD

2.1 Materials

Sorption isotherms of three different types of commercial SLC were tested. The three tested commercial products were based on Portland cement, calcium aluminate cement, calcium sulphate and small amount of silica fume. The three tested product were:

- A. Normal SLC with a water to binder ratio of about 1.0. This product is generally used in non-industrial constructions.
- B. Rapid-drying SLC, which is similar to the above product, but is used with a lower water to binder ratio (about 0.7) to give the product a higher degree of self-desiccation. This product is mainly used in renovation as it allows foot traffic in 1-2 hours and final covering in 1 day.
- C. SLC for industrial floors, also containing slag as a binder and a higher amount of polymer to increase the abrasion resistance [17]. The water to binder ration was about 0.6. The product allows medium heavy rolling equipment.

The products were mixed according to the manufacturers guidelines and left to hydrate, the first 24 hours in open air, approximately 20 °C and 50% RH, and after that in sealed glass jars. Small amounts of water were added to the specimens in the jars to prevent drying. Test specimens were cut from the centre of casted cylinders to avoid edge effects and carbonation. Specimens had hydrated for a minimum of 12 months prior to testing, if not otherwise stated. The sizes of the specimens were in the order of 4 mm with masses in the range of 50-130 mg. Specimens exposed to atmospheric conditions for three months were considered to be carbonated.

2.2 Method

A sorption balance (DVS 1000, Surface Measurements Systems, London, UK) was used to determine sorption isotherms and scanning curves. type of instrument has previously been used in the study of sorption on various materials, for example, food stuffs [18], plant material [19] and inorganic building materials [20]. With this instrument it is possible to measure sorption when the RH is changed in steps and as ramps. A flow of dry nitrogen gas is divided into two gas streams of which one is saturated with water vapour and the other left dry, see Fig. 2. By mixing different proportions of the gases, RH between 0 and 100% can be generated, although practical reasons, the upper limit is 98% RH.

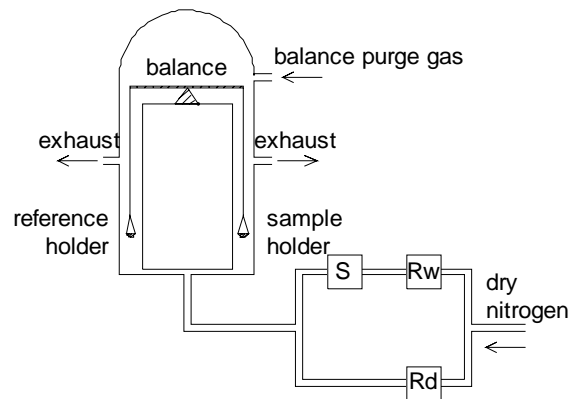

Figure 2 – Schematic picture of the DVS 1000 sorption balance. A flow of dry nitrogen gas is divided into two gas streams where one is saturated with water vapour, by bubbling through liquid water (S) and one is kept dry. The flow rates are controlled by two mass flow regulators (Rw and Rd). By mixing different proportions of the two gases, the desired RH can be generated.

Test cycles with several measurement steps and ramps have been used in the present measurements, Fig. 3. The test specimen is exposed to these relative humidities and the mass change of the specimen is continuously measured. A normal test cycle for one specimen lasted 8-12 days in the present study. The environment in the sorption balance was free from carbon dioxide during the measurements. The trueness was $\pm 1.0\%$ RH and the balance resolution was $0.1 \mu\text{g}$.

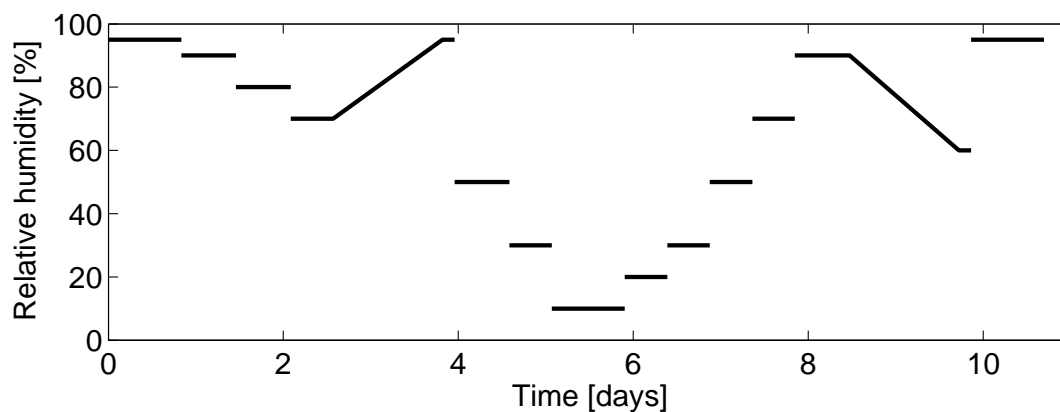

Figure 3 – Typical RH test cycle used in the present study. The test cycle starts and ends at 95% RH and includes two ramps for scanning curves, one from desorption to absorption and one from absorption to desorption.

Scanning ramp rates were about 100 minutes per % RH. After each scanning ramp, the relative humidity was kept at the final ramp value for 120 minutes validating that each scan was close to equilibrium. The change during these 120 minutes was less than 0.03% moisture content.

2.3 Performed tests

Sorption isotherms for the three self-levelling flooring compounds described above were measured with the sorption balance. The influence of different amounts of mixing water, different temperatures, age and carbonation were also measured.

2.4 Evaluation

Steady state measurements were made until the specimens had almost reached equilibrium. The final part of the curve was then curve-fitted and extrapolated with the equation

$$m(t) = m_0 + (m_f - m_0)e^{-k(t-t_0)} \quad (1)$$

where $m(t)$ is the mass at time t , m_0 is the initial mass at the start of the curve-fitting, m_f is the final mass, k is a constant and t_0 is the initial time at the start of the curve-fitting, see Fig. 4. The curve fitting was done in MATLAB 6.5 with a least square method. The correction never corresponded to more than 6% of the total mass change in each time step. The final sorption isotherms shown in the figures are curve fitted between the measurement points with a general spline function.

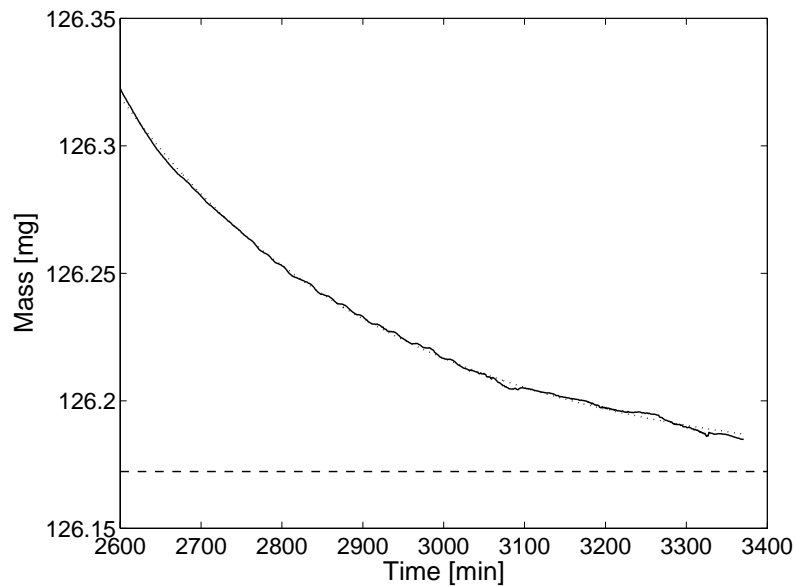

Figure 4 – Extrapolation of the final part of a measurement step in the sorption balance. Solid line is measured values, dotted line curved fitting of measured values and dashed horizontal line extrapolated equilibrium value used in evaluations.

For one material, SLC A, two measurements were performed with specimens casted at different occasions, but with material from the same batch. The mean relative difference in moisture content between the two measurements was 5%.

3 RESULTS AND DISCUSSION

3.1 Sorption isotherms

Results of measurements of SLC A-C are presented in Figs. 5-7. Results are given as moisture content (dry weight) as a function of RH. SLC B has a higher moisture sorption than SLC A. This may be an effect of the lower water to binder ratio of SLC B (see subsection 3.2), but also due to the larger amount of paste in SLC B. The sorption isotherm of SLC C for industrial floors has a different appearance than the sorption isotherms for SLC A and B. This might be an effect of the slag content and the lower water to binder ratio.

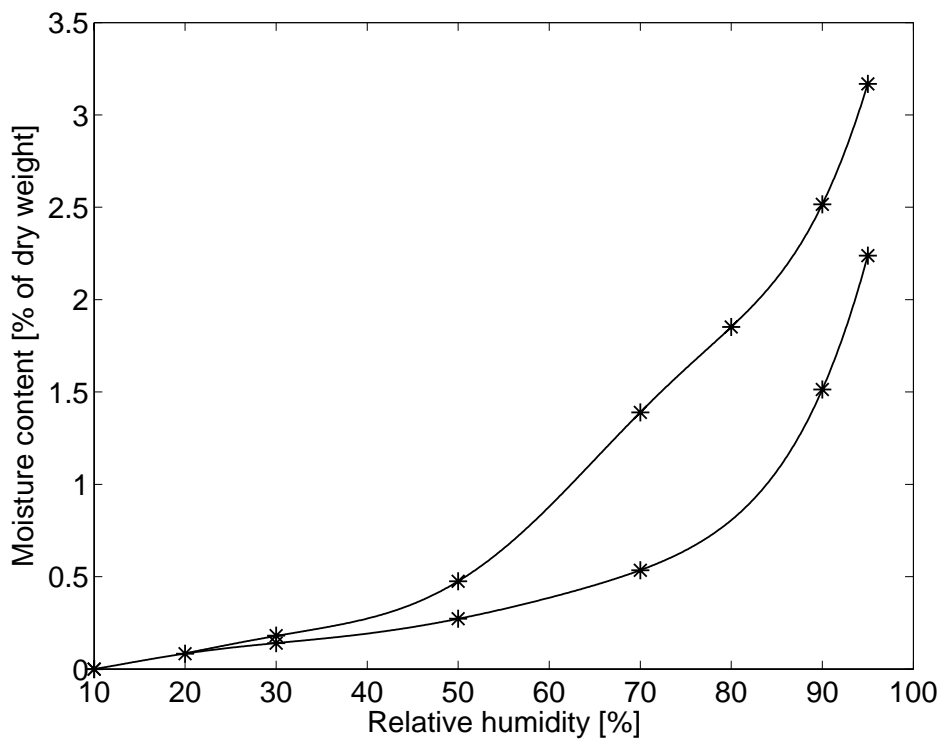

Figure 5 – Sorption isotherm of flooring compound A. Stars are measured values.

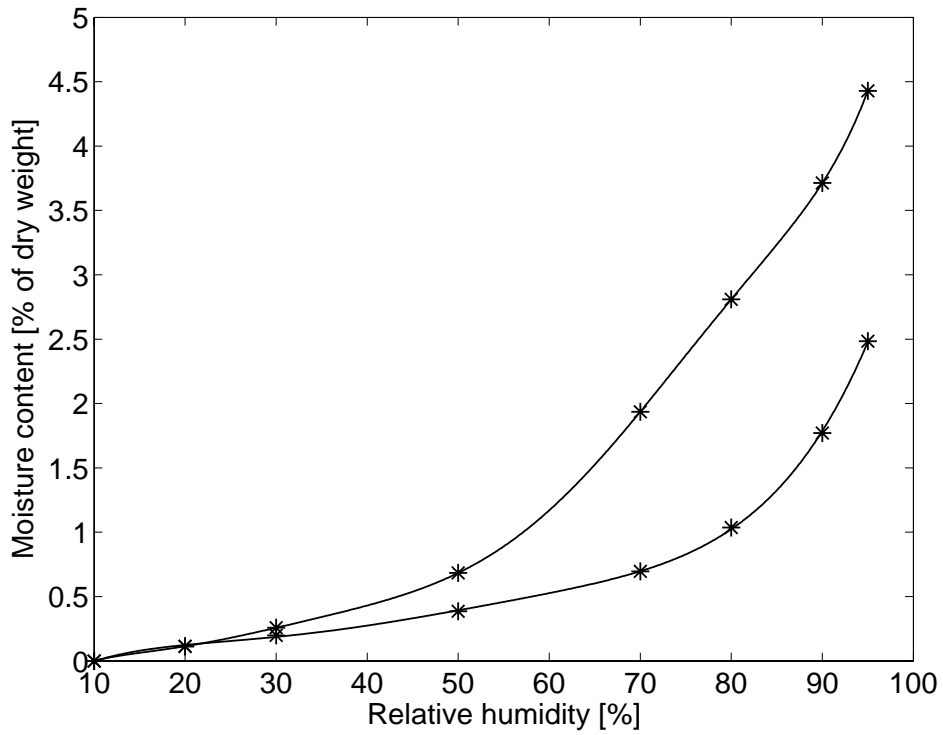

Figure 6 – Sorption isotherm of flooring compound B. Stars are measured values.

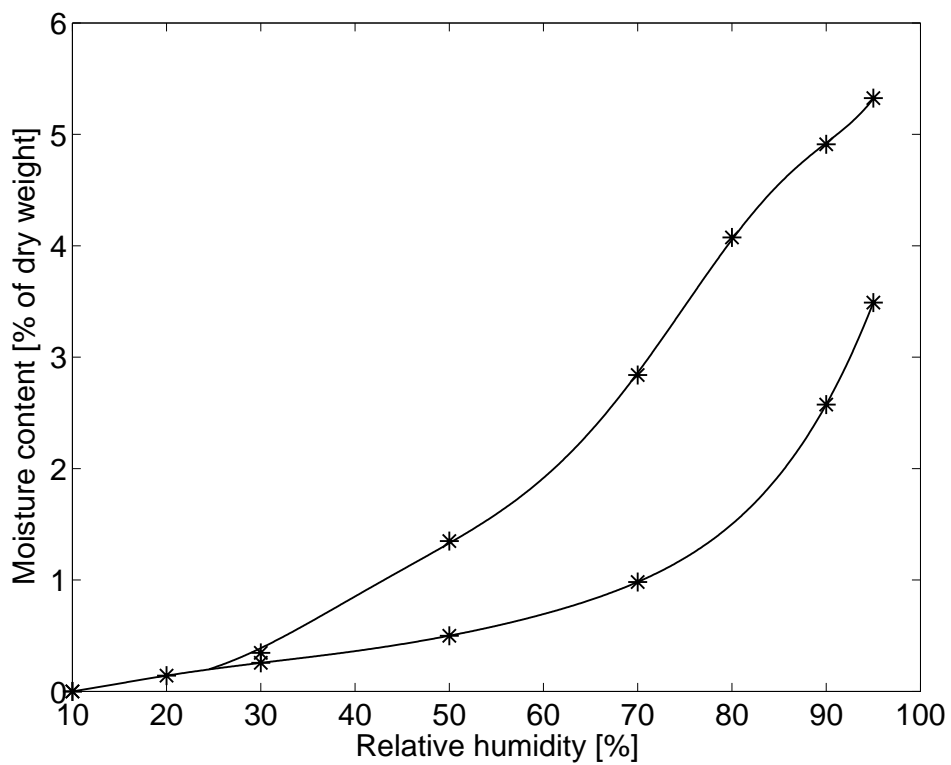

Figure 7 – Sorption isotherm of flooring compound C. Stars are measured values.

3.2 Influence of water to binder ratio

The influence of water to binder ratio was investigated by casting specimens of product A with 20% less and 10% more mixing water than recommended. The result indicates that a higher water to binder ratio results in lower sorption, although no difference was seen for normal and +10% mixing water in absorption. A decrease in water to binder ratio results in lower pore volume and a different pore size distribution with a larger amount of smaller pores. A smaller pore has a relatively larger surface area and will be water filled at lower RH than larger pores. As a result specimens casted with lower water to binder ratio will contain more moisture at the same RH in the hygroscopic range.

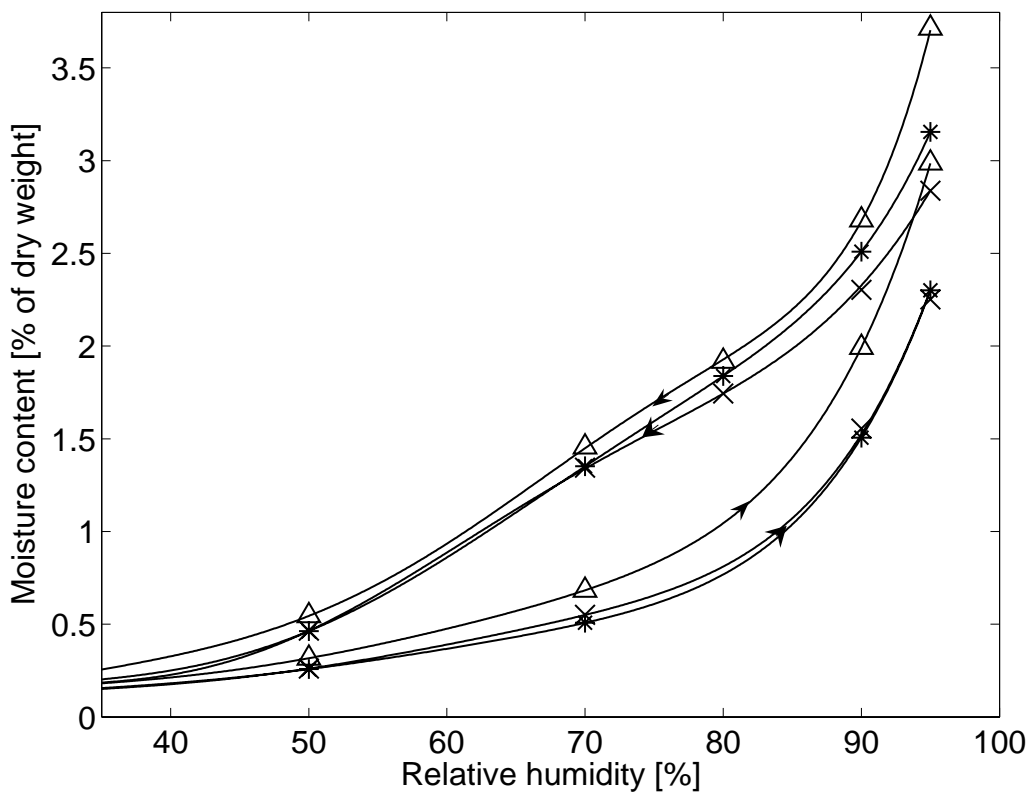

Figure 8– Sorption isotherms of SLC A casted with normal amount of mixing water (stars), 10% more mixing water than recommended (x-marks) and 20% less mixing water than recommended (triangles). Measurement values below 40% RH showed only small differences.

3.3 Influence of temperature

The influence of temperature on moisture sorption was studied by measurements at 10, 20 and 40 °C. As can be seen in Fig. 9, the moisture sorption capacity is lower at higher temperature, that is, an increase in temperature results in an increase in RH at constant moisture content. This behaviour is in qualitative agreement with the Clausius-Capeyron equation [21].

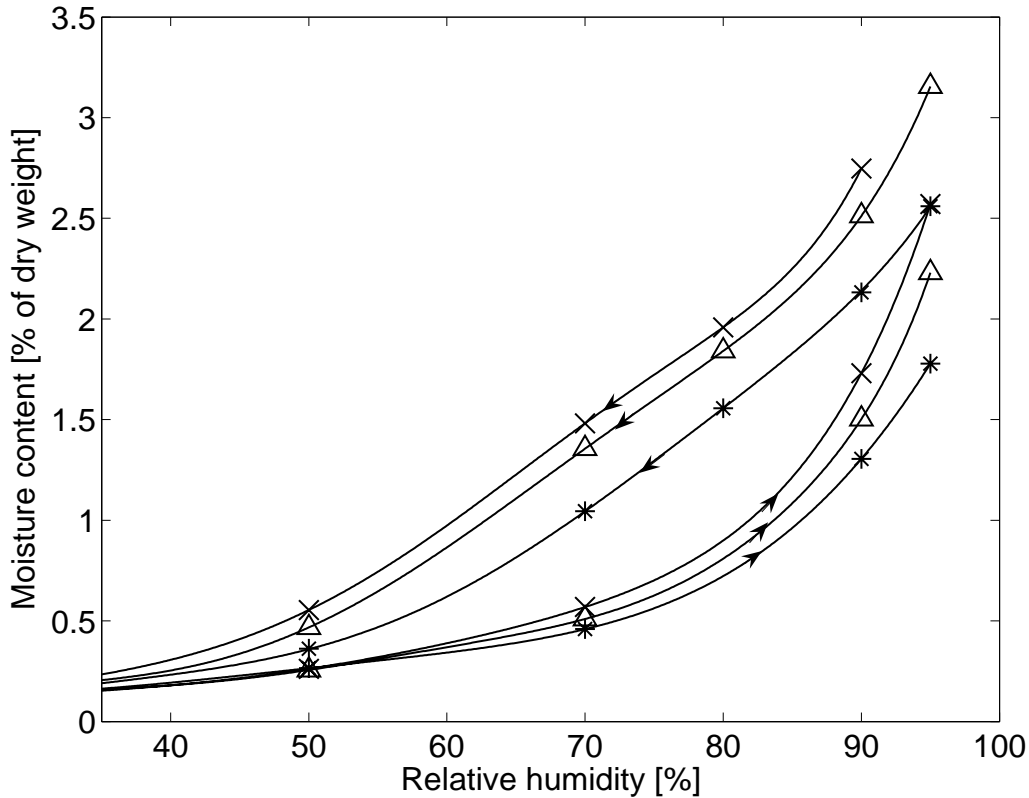

Figure 9 – Sorption isotherms of SLC A at the following temperatures: 10 °C (x-marks), 20 °C (triangles) and 40 °C (stars). Measurement values below 40% RH showed only small differences.

3.4 Influence of age

The structure of the material gradually develops with time until hydration has stopped. As the measurements of sorption isotherms in the sorption balance are relatively fast, it is a suitable instrument for determining sorption isotherms etc. on not completely hydrated materials. Sorption isotherms for SLC A presented in Fig. 10 were determined at 1, 3 and 12 months of age. A difference due to hydration can be seen, but the major part of the sorption isotherm was already developed after one month.

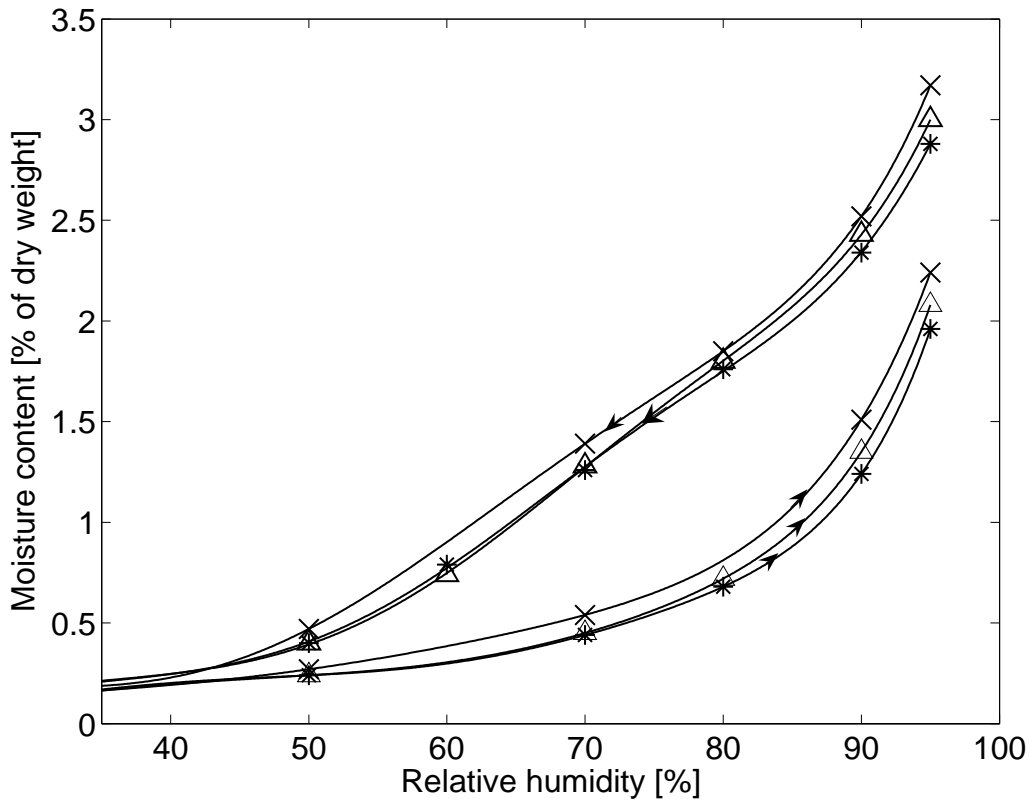

Figure 10 – Sorption isotherm of SLC A at 1 month (stars), 3 months (triangles) and 12 months (x-marks) of age. Measurement values below 40% RH showed only small differences.

3.5 Scanning curves

The following scanning curves for SLC A, are presented in Figs. 11 and Fig. 12.

- absorption 70-90% RH after desorption (Fig. 11)
- desorption 90-70% RH after absorption (Fig. 11)
- absorption 60-95% RH after desorption (Fig. 12)
- desorption 95-70% RH after absorption (Fig. 12)

When changing sorption mode, a small change in moisture content leads to a significant change in RH. This seems to be valid both when scanning in both directions.

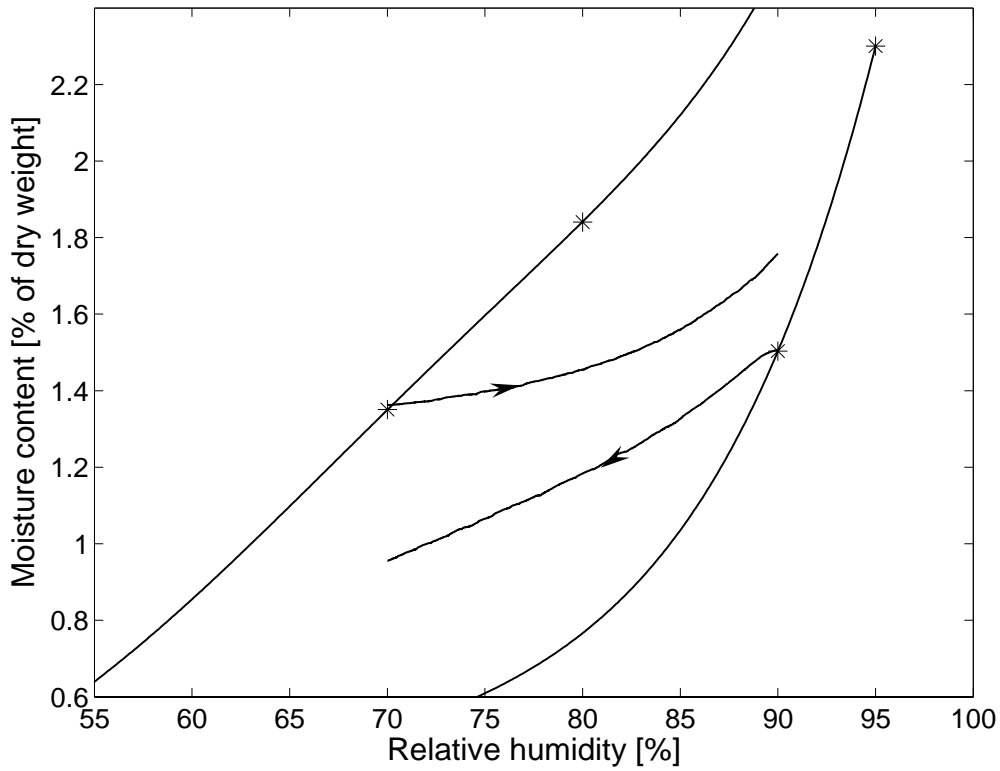

Figure 11 – Scanning curve for SLC A, absorption from desorption mode (70 to 90% RH) and desorption from absorption mode (90 to 70% RH).

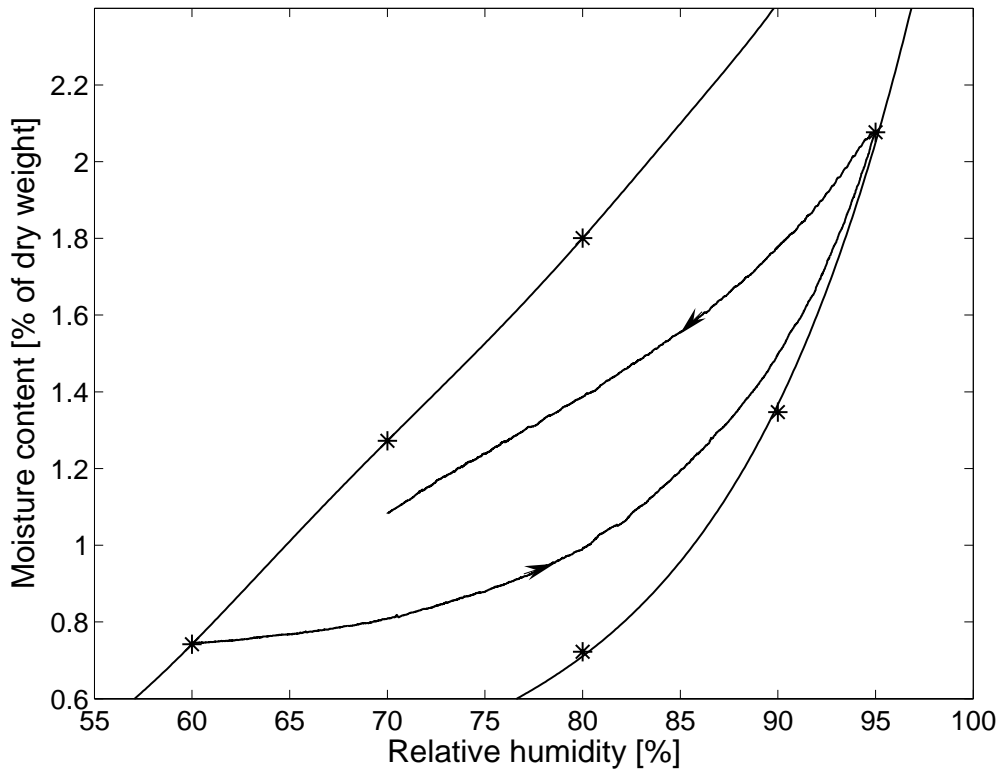

Figure 12 – Scanning curve for SLC A (three months old), absorption from desorption mode (60 to 95% RH) and desorption from absorption mode (95 to 70% RH).

3.6 Carbonation

Carbonation is the process where carbon dioxide from air dissolves in the pore solution and reacts with components in the material. Carbonation of ettringite [22] and calcium aluminate cement based materials [23] leads to a slightly more open material, while carbonation of Portland cement based materials results in a denser material [24]. Measurements on carbonated and non-carbonated specimens of SLC A are presented in Fig. 13. Only minor differences were seen.

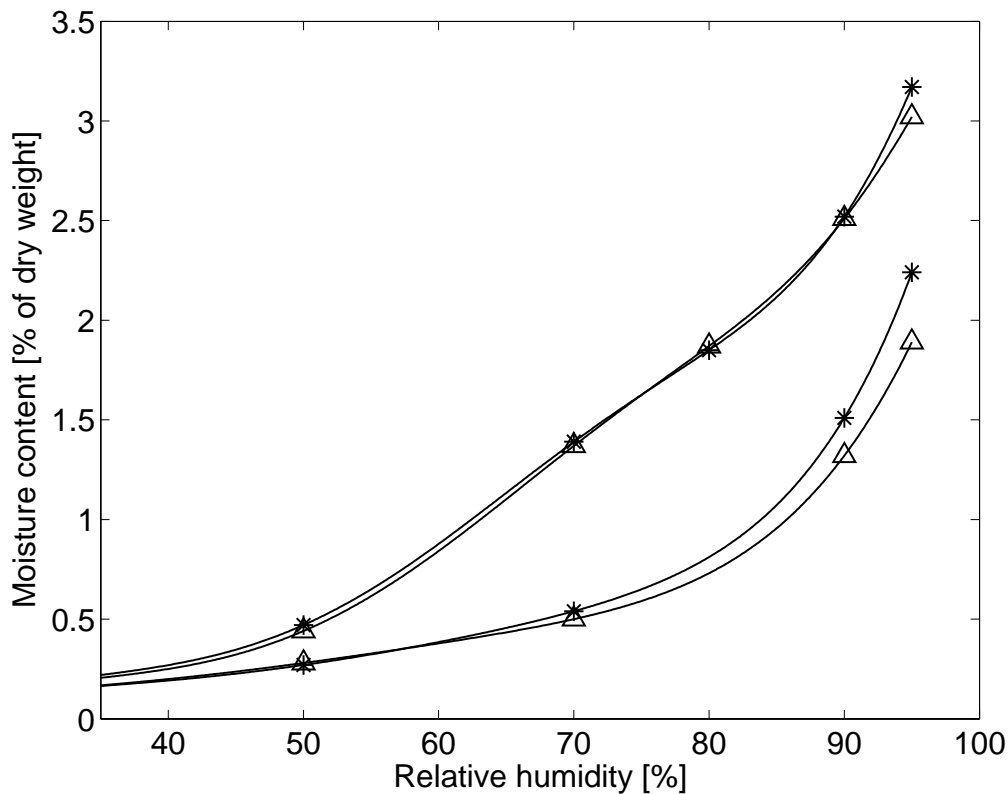

Figure 13 – Measurements performed on carbonated (triangles) and non-carbonated (stars) specimens of SLC A.

3.7 General discussion

Knowledge of scanning curves makes it possible to do more accurate predictions of RH in materials changing sorption modes. As seen in Figs. 11 and 12 a small change in moisture content results in a large change in RH. The consequences of this for chemical reactions and biological growth is however somewhat unclear, as discussed in section 1.

Due to long durations of the measurements and limited resources it was only possible to perform tests with single test specimens, except for product A at 20 °C where double tests were made. The mean relative difference in moisture content between the two measurements was 5%.

The only reference found with measurements of a sorption isotherm of a flooring compound was Hedenblad [25]. The results are in the same range as ours, but the flooring compound used by Hedenblad did not have self-levelling properties and was probably of a different composition than the SLC used in this investigation. Hedenblad also measured at 0% RH, which we believe gives incorrect values for the SLC used in this investigation.

The sorption isotherm is gradually developing with time during the first year or longer, although the major part of the internal structure seems to be developed in one-month time. The RH in a young material will thus decrease, even if moisture cannot leave the material. Note that specimens in this investigation hydrated at 100% RH. The rate of hydration strongly decreases with decreasing RH.

Measurements of moisture sorption together with measurements of moisture transport properties [1] makes it possible to calculate and predict drying times, moisture loads and possible also ion transports and degradation rates. This is important because it is well known that other materials may take harm in contact with cementitious materials under high moisture loads.

REFERENCES

1. Anderberg, A. and Wadsö, L., "Moisture in Self-levelling Flooring Compounds. Part I Diffusion Coefficients." *Submitted*
2. Fennema, O.R., "Water and Ice", in *Food Chemistry*, O.R. Fennema, Editor. 1985, Marcel Dekker Inc. New York and Basel. pp. 23-67.
3. Adamson, A.W., "Physical Chemistry of Surfaces". 5th. John Wiley & Sons, Inc., 1990, 777 pp.
4. Labuza, T.P., Cassil, S., and Sinskey, A.J., "Stability of intermediate moisture foods. 2. Microbiology." *Journal of Food Science*, Vol. 37, 1972, pp. 160-162.
5. Bažant, Z.P. and Najjar, L.J., "Nonlinear water diffusion in nonsaturated concrete." *Materials and Structures*, Vol. 5No 25, 1972, pp. 3-20.
6. Nilsson, L.-O. "Temperature effects in relative humidity measurements on concrete - some preliminary results". *Proceedings, Building physics in the Nordic countries*. Lund 1987. pp. 456-462.
7. Iglesias, H.A. and Chirife, J., "Handbook of food isotherms: Water sorption parameters for food components". Academic Press, New York, 1982, 347 pp.
8. Jones, L. and Atkins, P., "Chemistry Molecules Matter and Change". 4th. W. H. Freeman and Company, New York, 2002., 998 pp.
9. Mattson, E., "Elektrokemi och korrosionslära". Ingemat Roos AB, Stockholm, 1987, pp.
10. Fog Nielsen, K., "Mould growth on building materials Secondary metabolites, mycotoxines and biomarkers" The Mycology group, Biocentrum-DTU. Technical University of Denmark: Lyngby. 2002, 80 pp.
11. Fagerlund, G., "Determination of pore size distribution by suction porosimetry." *Materials and Structures*, Vol. Vol. 6, No 33, 1973, pp. 191-201.
12. Fagerlund, G., "Determination of pore size distribution from freezing-point depression." *Materials and Structures*, Vol. Vol. 6, No 33, 1973, pp. 215-225.
13. Krus, M. and Kießl, K., "Determination of the moisture characteristics of porous capillary active materials." *Materials and Structures*, Vol. Vol. 31, 1998, pp. 522-529.

14. Janz, M., "Technique for Measuring Moisture Storage capacity at High Moisture Levels." *Journal of Materials in Civil Engineering*, Vol. September/October, 2001, pp. 364-370.
15. Zhang, L. and Glasser, F.P., "Critical examination of drying damage to cement pastes." *Advances in cement research*, Vol. No. 2, Apr, 2000, pp. 79-88.
16. Shimida, Y. and Young, J.F., "Structural changes during thermal dehydration of ettringite." *Advances in cement research*, Vol. 2001, 13, No 2 April Number, 2001, pp. 77-81.
17. Hoffman, A., "Effect of Redispersible Powders on the Properties of Self-Levelling Compounds". Technical paper, Wacker Polymer Systems, 20 pp.
18. Hébrard, A., et al., "Hydration properties of durum wheat semolina: influence of particle size and temperature." *Powder Technology*, Vol. 130, 2003, pp. 211-218.
19. Caro, Y., et al., "Plant Lipases: Biocatalyst Aqueous Environment in relation to Optimal Catalytic Activity in Lipase-Catalyzed Synthesis Reactions." *Biotechnology and Bioengineering*, Vol. 776, 2002, pp. 693-703.
20. Janz, M. and Johannesson, B.F., "Measurement of the Moisture Storage Capacity Using Sorption Balance and Pressure Extractors." *Thermal Envelope & Building Science*, Vol. 244, 2001, pp. 316-334.
21. Atkins, P.W., "Physical Chemistry". Sixth edition. Oxford University Press, 1998, 1014 pp.
22. Scrivener, K.L. "Historical and Present Day Applications of Calcium Aluminate Cements". *Proceedings*, International Conference on Calcium Aluminate Cements. Edinburgh, Scotland 2001. pp. 3-23.
23. Gaztañaga, M.T., Gonñi, S., and Guerrero, A. "Accelerated Carbonation of Calcium Aluminate Cement Paste". *Proceedings*, Calcium Aluminate Cements. Edinburgh, Scotland 2001. pp. 349-358.
24. Taylor, H.F.W., "Cement Chemistry". 2nd edition. Thomas Telford, London, 1997, 437 pp.
25. Hedenblad, G., "Material data for moisture transport calculations (In Swedish)". Bygghälsningsrådet: Stockholm. 1996, 53 pp.

Paper III

Method for simultaneous determination of sorption isotherms and diffusivity of cement based materials *(DRAFT)*

Anders Anderberg
Lars Wadsö

Introduction

Moisture in cementitious materials is an important issue in building science as most such materials contain excess water when hydrated and this water must be removed to prevent damage to a building and deterioration of the indoor air quality due to biological growth [1, 2] or alkaline degradation of polymers [3]. Moist or damp buildings have also in general been related to health effects in several studies [4].

Knowing moisture properties of materials is essential for calculating drying times and moisture loads and for predicting transport of other substances, biological growth and chemical reactions. Traditional methods to determine diffusion coefficients and sorption isotherms are extensive and time-consuming. Since moisture properties are moisture dependent several test specimens have to be prepared to cover a whole measurement range.

Cementitious materials are very fine porous and therefore it normally takes long time to determine moisture properties of such materials. Another issue is that they often contain large amounts of aggregates (e.g. limestone filler, sand, gravel and stone). A test specimen must at least be 4-5 times larger than the largest aggregate size to have a representative sample. Although aggregates only have a very minor contribution to moisture properties by themselves, the transition zones between the cement paste and the aggregate may play an important role. A simple and rapid method for determination of both diffusion and sorption properties would therefore save a lot of time.

Different models are used in other fields of science to determine diffusion and sorption properties in one measurement. In gravimetric methods [5, 6], a material with known geometry is exposed to step changes or continuous changes of a certain gas or liquid. The change in mass of the test specimen is continuously measured, giving the sorption isotherm, and out of the kinetics of the mass change and the known geometry of the specimen, it is possible to calculate the diffusion coefficient. In the time-lag method [7] a difference in partial pressure is applied over a test specimen. The pressure is stepwise kept constant at one side and the change of pressure on the other side is measured. Sorption and diffusion properties are later calculated out of the measured values.

Method

The method, which is a gravimetric method, is based on mass determination under changing relative humidity (RH) conditions. A small sample of known geometry is exposed to step-wise changes in RH. From the kinetics of the mass change the diffusivity can be calculated and from the final equilibrium mass value the sorption isotherm can be calculated. To get a well-defined geometry of our samples we have cast our materials in short pieces of stain-less steel tubes. In this way we get a well-defined geometry with one-dimensional moisture flow.

To generate the RH steps we have placed our samples in a sorption balance (DVS-1000, Surface Measurement Systems Ltd.), Fig 1. They have been freely suspended in the gas flow line, attached to the balance by a strip of aluminium foil wrapped around the stainless steel tube with the sample. As the gas flow velocity is 0.8 cm/s we assume that surface mass flow resistances are negligible.

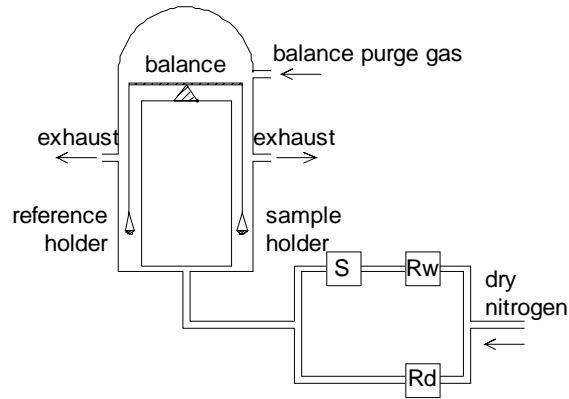

Figure 1– Schematic picture of the DVS 1000 sorption balance. A flow of dry nitrogen gas is divided into two gas streams where one is saturated with water vapour, by bubbling through liquid water (S) and one is kept dry. The flow rates are controlled by two mass flow regulators (Rw and Rd). By mixing different proportions of the two gases, the desired RH can be generated.

A flow of dry nitrogen gas is divided into two gas streams of which one is saturated with water vapour and the other left dry. By mixing different proportions of the gases, RH between 0 and 100% can be generated, although practical limits are 0-98% RH. The trueness of RH is 1.0% and the balance resolution 0.1 μg .

The test cycle used in this report is shown in Fig. 2. The cycle last about 9 days.

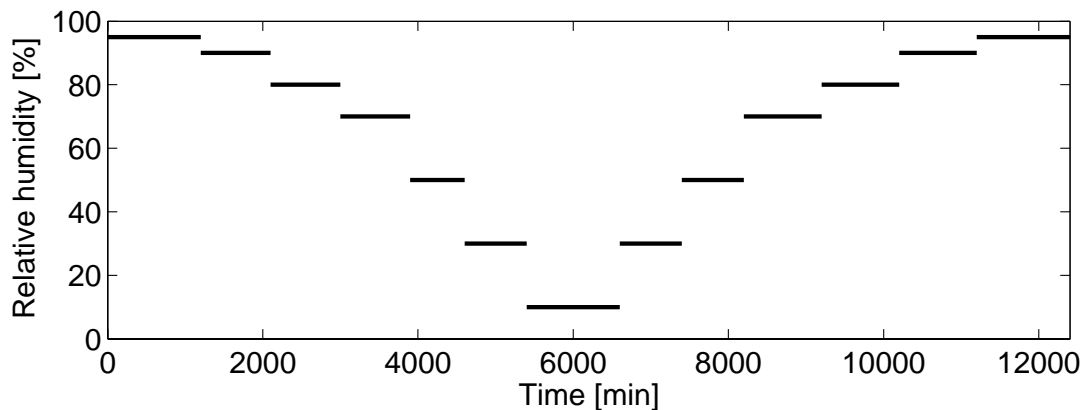

Figure 2 – Test cycle used in experiments. Measurements started and ended at 95% RH.

Sorption isotherm

Each measurement step was made until the specimen had almost reached equilibrium. The final part of the curve was then curve-fitted and extrapolated with the equation,

$$m(t) = m_0 + (m_f - m_0)e^{-k(t-t_0)} \quad (1)$$

where $m(t)$ is the mass at time t , m_0 is the initial mass at the start of the curve-fitting, m_f is the final mass, k is a constant and t_0 is the initial time at the start of the curve-fitting. The curve fitting was done in MATLAB 6.5 with a least square method. The correction never corresponded to more than 12% of the total mass change in each time step. For more details, see [8].

Diffusion coefficient

As is principally shown in Fig. 3, each step in RH gives an initial mass change that is essentially linear when drawn on a square root of time scale. This first initial part can be used to calculate the diffusivity [9]:

$$\frac{\Delta m}{\Delta m_\infty} = \frac{4}{\sqrt{\pi}} \sqrt{\frac{Dt}{L^2}} \quad (2)$$

Here, Δm (g) and Δm_∞ (g) are the mass of the sample at time t (s) and at infinite time, respectively, D (m²/s) is the diffusivity and L (m) is the thickness of the sample. The diffusion coefficient with vapour content as gradient was then calculated by:

$$D_v = D \frac{dc}{dv} \quad (3)$$

where D_v (m²/s) is the diffusion coefficient as a function of vapour content, D (m²/s) is the diffusivity from Eqn. 1, dc is the concentration difference of moisture (g/m³) in the measurement step and dv is the difference in vapour content (g/m³). Note the difference between D_v and D , although their units appear to be the same.

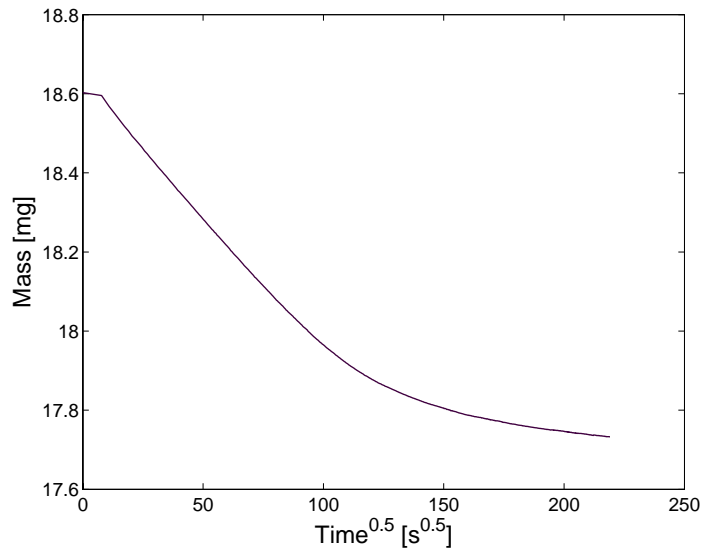

Figure 3 – Typical measurement step where the mass is plotted as a function of the square root of time. The first linear part of the measurement is used to calculate the diffusivity.

Materials

One product was chosen for these studies. We have previously measured diffusion coefficient on this product with the cup method [10]. The tested product was a commercial self-levelling flooring compound (SLC) based on Portland cement, calcium aluminate cement, calcium sulphate and small amount of silica fume. A typical composition of the mineral part of such an SLC is shown in Table 1. The product was a normal SLC with water to binder ratio of about 1.0. This product is generally used in non-industrial constructions.

Table 1 – Typical composition of the mineral part (excluding admixtures) of an SLC [11]

Portland cement	less than 3%
Calcium aluminate cement	around 17%
Calcium sulphate	around 7%
Limestone filler (calcite)	around 30%
Sand (siliceous)	45-50%

The products were mixed according to the manufacturers guidelines, casted into the steel cylinders and left to hydrate, the first 4 hours in open air, approximately 20 °C and 50% RH, and after that in an exiccator with 100% RH and no air exchange.

SLC are suitable for these kinds of measurements as the maximum aggregate size is small, normally around 1 mm.

Results

Figure 3 shows a typical mass response to a step in RH. It is seen that there is an initial linear part, but also that there is a long and slow attainment of sorption equilibrium typical of cementitious materials.

Tables 2 and 3 give the calculated diffusion coefficients and sorption isotherm and data from previous measurements on the same material. A good agreement can be seen for the diffusion coefficients, although more measurements need to be performed to validate the method. A

hysteresis effect between measurements values obtained in desorption and absorption mode was also noted.

Table 2 – Diffusion coefficients measured with the cup method and new method

Cup method		New method		
RH [%]	Diffusion coeff. $10^{-6} \text{ m}^2/\text{s}$	RH [%]	Desorption Diffusion coeff. $10^{-6} \text{ m}^2/\text{s}$	Absorption Diffusion coeff. $10^{-6} \text{ m}^2/\text{s}$
55 – 75.1	0.67	10-30	0.31	0.40
75.1 – 84.5	0.78	30-50	0.44	0.34
84.5 – 93.7	0.97	50-70	0.82	0.39
93.7 – 96.6	1.84	70-80	0.70	0.53
96.6 – 98.8	3.16	80-90	1.01	0.73
		90-95	1.39	0.89

Table 3 gives the sorption isotherm from previous measurements and from measurements where the specimen was casted in a steel cylinder. As the new measurements were made from the same material in the same sorption balance they should give the same results. The deviations seen may be explained by the fact that it was hard to cast the test material in the small cylinders. In the previous measurements, test specimens were cut out from the centre of a large specimen thus avoiding edge effects etc.

Table 3 – Sorption isotherm measured in sorption balance in previous measurements and with the new method where specimens are cast in a steel cylinder.

RH	Previous measurements	New method
95	3.02	2.81
90	2.51	2.53
80	1.87	2.13
70	1.37	1.58
50	0.44	0.76
30	0.17	0.24
10	0	0
30	0.14	0.18
50	0.28	0.33
70	0.50	0.57
80	0.77	0.82
90	1.32	1.30
95	1.89	1.79

Discussion

As can be seen in Tables 2 and 3 there is a good agreement between the results obtained with the present method and those obtained previously. As the previous measurements of diffusion coefficients took about 8 weeks and the present measurement took only 9 days, the present method is very efficient and it also requires less laboratory work. However, the equipment used for the present measurements is more expensive than the one used to do cup measurements of diffusion coefficients.

The stainless steel tube used in these measurements was found to be too small. It was difficult to cast test material into the cylinder. With a larger test cylinder this problem would be avoided.

An advantage with this method is that it is possible to decide the precise intervals you want to measure the diffusivity and that more measurement intervals will not involve more test specimens.

Cementitious materials usually show a quick initial response to changes in RH, but later a slow attainment of equilibrium. Compared to many other types of materials (textiles, pharmaceuticals etc.) measurements of sorption isotherms may take very long time. To shorten the time of a measurement one can stop before equilibrium is attained and then extrapolate the measured curve.

The present method can of course also be used for other materials of well-defined geometry.

References

1. Fennema, O.R., "*Water and Ice*", in *Food Chemistry*, O.R. Fennema, Editor. 1985, Marcel Dekker Inc. New York and Basel. pp. 23-67.
2. Fog Nielsen, K., "*Mould growth on building materials Secondary metabolites, mycotoxines and biomarkers*" The Mycology group, Biocentrum-DTU. Technical University of Denmark: Lyngby. 2002, 80 pp.
3. Sjöberg, A., "*Secondary emissions from concrete floors with bonded flooring materials - effects of alkaline hydrolysis and stored decomposition products*" P-01:2, Department of Building Materials. Chalmers University of Technology: Göteborg. 2001, 188 pp.
4. Bornehag, C.-G., et al., "Dampness in Building and Health Nordic Interdisciplinary Review of the Scientific Evidence on Associations between Exposure to "Dampness" in Buildings and Health Effects (NORDDAMP)." *Indoor Air*, Vol. 11, 2001, pp. 72-86.
5. Marais, S., et al., "Permeametric and microgravimetric studies of sorption and diffusion of water vapor in an unsaturated polyester." *Polymer*, Vol. 41, 2000, pp. 2667-2676.
6. Muoi, T., Yi-Ching, H., and Yan-Ping, C., "Sorption and Diffusion of Supercritical Carbon Dioxide into Polysulfone." *Journal of Applied Polymer Science*, Vol. 94, 2004, pp. 474-482.
7. Taveira, P., Mendes, A., and Costa, C., "On the determination of diffusivity and sorption coefficients using different time-lag models." *Journal of Membrane Science*, Vol. 221, 2003, pp. 123-133.
8. Anderberg, A. and Wadsö, L., "Moisture in Self-levelling Flooring Compounds. Part II. Sorption Isotherms." *Nordic Concrete Research*, Vol.
9. Crank, J., "The mathematics of diffusion". Vol. Second edition. Oxford University Press, 1975, 414 pp.
10. Anderberg, A. and Wadsö, L., "Moisture in Self-levelling Flooring Compounds. Part I Diffusion Coefficients." *Nordic Concrete Research*, Vol.
11. Scrivener, K.L., et al. "*Effect of CO₂ and humidity on the Mechanical Properties of a Formulated Product Containing Calcium Aluminate Cement*". *Proceedings*, Ibausil. Weimar, Germany 1997, vol. 1. pp. 745-752.

Paper IV

A METHOD FOR SIMULTANEOUS MEASUREMENTS OF HEAT OF HYDRATION AND RELATIVE HUMIDITY

Lars Wadsö and Anders Anderberg

Building Materials, Lund University, Box 118, 221 00 Lund, Sweden

Abstract

Isothermal (conduction) calorimetry is a general method to study reaction processes by measuring the heat produced under isothermal conditions. The method is ideally suited for studies of cement hydration as the hydration reactions produce large amounts of heat. In the calorimeters we are using the sample is kept in a closed glass ampoule during the measurement. We have now further developed this technique by inserting a relative humidity probe in the glass vial. We can thus measure both thermal power (reaction rate) and relative humidity (self-desiccation) simultaneously. We have done test measurements on cement pastes with two types of cements and different w/c-ratios. At high w/c the measurements are good, but at low w/c the relative humidity measurements show large variations. We believe that this is caused by water vapour being lost through small leakages in the ampoules, and that this vapour cannot be replaced by vapour from the relatively dry and vapour tight low w/c cement pastes. It is thus essential to have very vapour tight ampoules for this type of measurement to work.

1. Introduction

The self-desiccation properties of concrete and other cementitious products are of large interest. The large amounts of water left after the hydration of ordinary high water/cement ratio (w/c) concrete is often a problem in the modern high tempo building process. In Sweden we have had many cases of floorings being degraded because they have been laid on concrete that was not dried enough. Two potential ways to overcome such problems is to use low w/c self-desiccating concrete or using a self-desiccating self-levelling flooring compound on top of an ordinary concrete.

The self-desiccation of a low w/c concrete is caused by the hydration reactions consuming water and thus lowering the relative humidity of the concrete. The self-desiccation of a cementitious material is best studied by measuring the relative humidity

of a gas phase in contact with the material in a closed container. Typically, a sample is cast in a jar that is closed by a vapour-tight lid. Inside the jar is placed a relative humidity probe. As the jar is vapour-tight, no vapour can escape and the relative humidity measured in the gas phase is the same as that of the material (or the pores inside the material). In whole constructions it is also possible to measure self-desiccation by measuring the relative humidity in a position inside a construction that has not been influenced by the external relative humidity.

Isothermal heat conduction calorimetry is the measurement of heat production rate (thermal power) at constant temperature conditions. As the thermal power is proportional to the rate of the hydration (reaction) isothermal calorimetry is an interesting technique to study different aspects of the hydration process. Some examples of studies that can be made:

- Determination of retardation by additives.
- Measurement of hydration rate as a function of temperature.
- Quality control of cement.

More examples can be found in [1] and [2]. In this paper we describe a method to simultaneously measure self-desiccation (relative humidity) and rate of hydration (thermal power). As far as we know only Penttala [3] has made measurements of relative humidity inside a calorimetric chamber before us.

2. Method

The isothermal calorimeters used (TAM Air, Thermometric AB, Järfälla, Sweden, www.thermometric.se) consists of eight isothermal heat conduction calorimeters in a thermostat (Figure 1). Each calorimeter holds a 20 ml glass or steel ampoule with the sample (Figure 2). The baseline stability of the TAM Air over a time period of a week is better than $\pm 5 \mu\text{W}$.

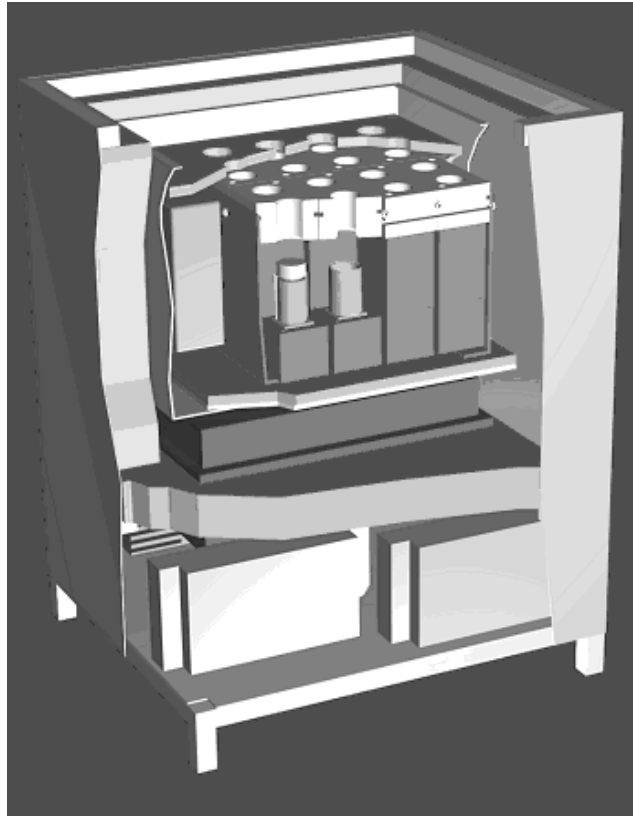

Figure 1 - A cut-away picture of the eight-channel TAM Air isothermal calorimeter used in this study. The samples are kept in the ampoules, two of which can be seen in the figure. Below the calorimeters is an air thermostat that together with the insulation provides a constant temperature environment for the calorimeters.

The samples of cement paste, cement mortar or concrete with small sized aggregate are placed in a 20 ml glass ampoule (Figure 2). As quite a lot of heat is produced during cement hydration only a small sample is needed; here we have used samples of about 10 g cement paste (about 4 ml) on the bottom of each ampoule. This leaves enough space for the relative humidity sensor above the sample.

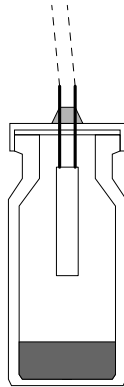

Figure 2 - A schematic drawing of the calorimetric glass ampoule with a cement paste sample and a relative humidity sensor inserted through the seal.

The relative humidity sensors were of type HumiGuard (Nordisk Industrifysik AB, Malmö, Sweden). This is a disposable sensor that does not need to be calibrated. It has been used quite a lot in Sweden on building sites. Calibration is not needed, but a sensor from the same batch of sensors is used as a reference and is kept above a calibration vial with 85% relative humidity. During each measurement the electrical conductivity and the temperature of each sensor (both measurement sensor and reference sensor) is measured. The relative humidity is then calculated with a computer program.

Normally, each HumiGuard sensor consists of a resistive RH-sensor and a temperature sensor (a thermistor). In the present set-up we only used the RH-sensor as the temperature of the calorimeter is very well known. During the present experiments the samples and the references were at approx. the same temperature of 20°C.

3. Materials

The measurements were made with two cements from Cementa AB (Sweden):

- Portland cement EN 197-1 - CEM I 42,5 R "Standardcement"
- Portland-limestone cement EN 197-1 - CEM II/A-LL 42,5 R "Byggcement"

Each cement was mixed with tap water to the following water-cement ratios: 0.35, 0.40, 0.45 and 0.50. For the samples with water/cement-ratio 0.45 and 0.50 some sand was added to prevent separation. Two samples from each mix were used in the combined measurements of thermal power and relative humidity.

4. Results

Figure 3 shows the result from the relative humidity measurements and Figures 4 and 5 show the results from the calorimetric measurements.

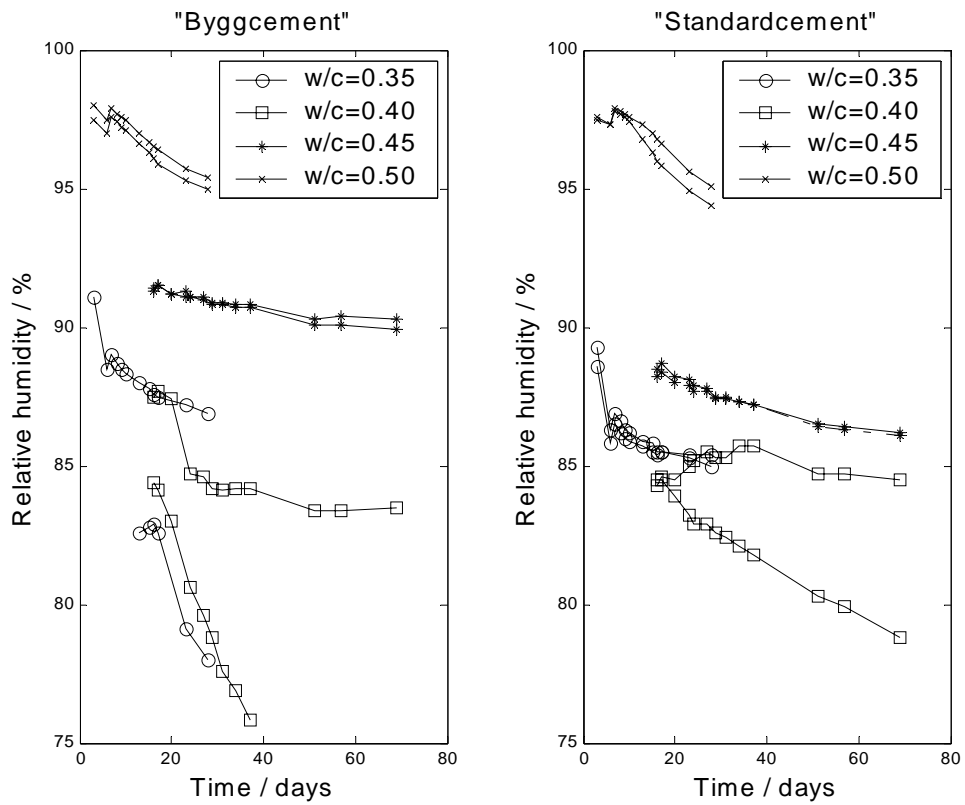

Figure 3 - Results from the measurements of relative humidity on a Portland limestone cement (left) and a Portland cement (right). Four water-cement ratios were used: 0.35 (circles), 0.40 (squares), 0.45 (stars), and 0.50 (crosses).

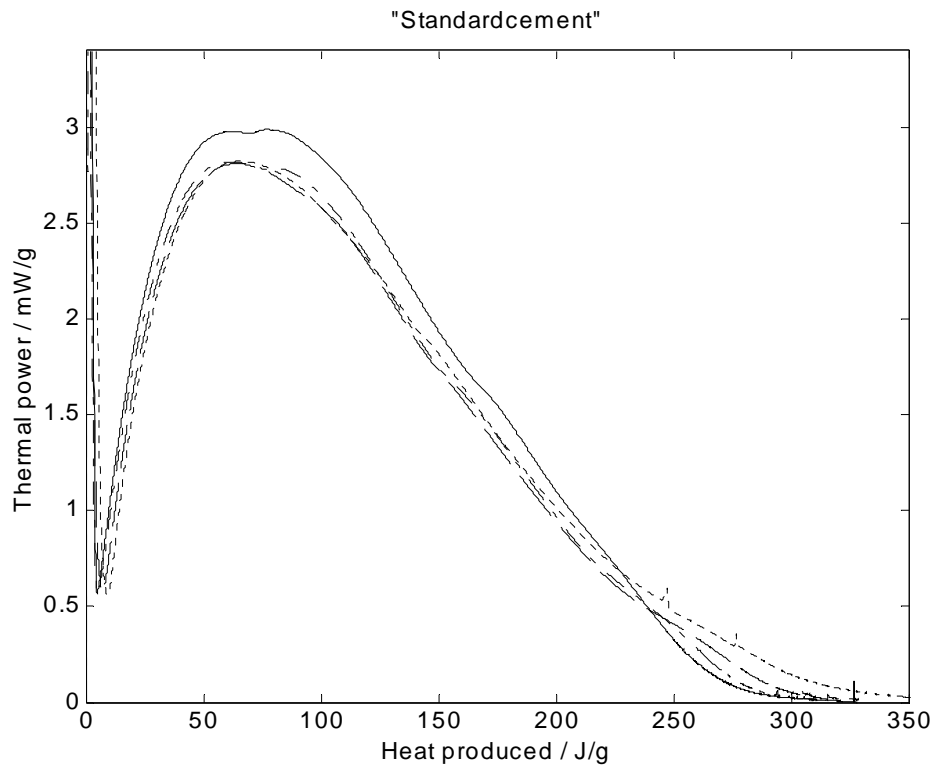

Figure 4 - Specific thermal power (watts per gram cement) as a function of produced heat (joules per gram cement) for the Portland cement. Each curve is a mean of two measurements on samples from the same mix. The differences between two curves were never more than 0.1 mW/g. W/c=0.35 (solid), w/c=0.40 (dash-dotted), w/c=0.45 (dashed) and w/c=0.50 (dotted).

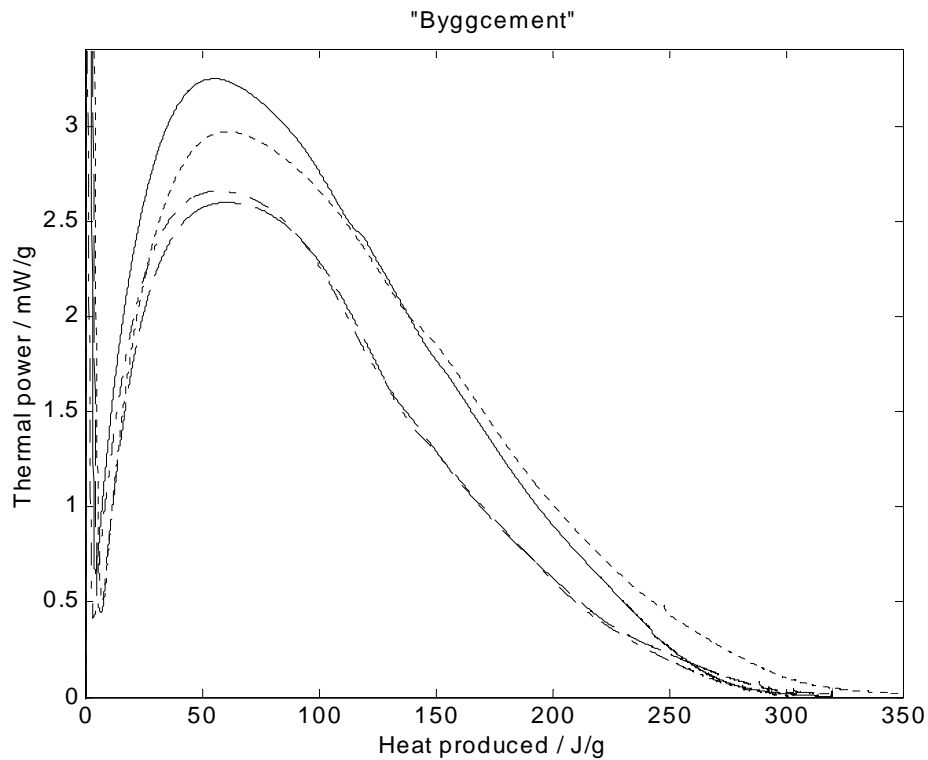

Figure 5 - Specific thermal power (watts per gram cement) as a function of produced heat (joules per gram cement) for the Portland limestone cement. Each curve is a mean of two measurements on samples from the same mix. The differences between two curves were never more than 0.1 mW/g. W/c=0.35 (solid), w/c=0.40 (dash-dotted), w/c=0.45 (dashed) and w/c=0.50 (dotted).

5. Discussion

The relative humidity measurements were successful at high w/c-ratios (0.45 and 0.50). At lower w/c (0.35 and 0.40) there were substantial differences between duplicate curves. We believe that this was caused by the fact that the low w/c samples were unable to supply enough moisture to the headspace of the ampoule; both because the low w/c

cement contains less water and because low w/c cement has much lower diffusivities than the high w/c-samples. The general idea of the method is that there should be water vapour equilibrium within the ampoule, i.e. there should be no relative humidity gradients in the ampoules. The differences between different samples are an indication that this has not been the case.

We have two possible explanations to the variation seen in the results from low w/c samples:

- Even very slight leakages remove enough vapour from the head-space to lower the relative humidity there. After the measurements we have tested the vapour tightness of the ampoules. With water in the ampoules and an external relative humidity of about 40% we found that some of the ampoules lost up to 5 mg of water during a 14 days period.
- It may also be that the relative humidity sensor itself has such high vapour absorption that the head-space is depleted of water vapour. To test this hypothesis we measured the sorption isotherm of a HumiGuard sensor and found that it quickly absorbed about 0.4 mg of water vapour in the range 0-85% RH and about 1 mg in the range 85-95% RH (slow absorption). We do not know in what RH-state the sensors were when we installed them, but it is possible that they need up to 0.5 mg to come into equilibrium with the relative humidity of the cement pastes.

It seems reasonable to assume that either of these hypotheses (or both) can explain the strange results with low w/c-samples. The headspace at high relative humidity at 20°C holds about 0.2 mg water vapour, so if the two factors discussed above are active the cement pastes have to supply several milligrams of water vapour to the headspace to keep up the relative humidity.

We conclude that the ampoules have to be very vapour tight for the method to work and that the relative humidity sensor should have as low moisture capacity as possible.

Figures 4 and 5 show the specific thermal power (watts per gram cement) as a function of produced heat (joules per gram cement). This is both a convenient and illustrative way to compare calorimetric cement hydration curves. The produced heat Q (J/g) on the x-axis can be seen as the extent of reaction ξ (g(reacted cement))/g(cement); more produced heat means that the hydration reaction has proceeded further:

$$\xi = \frac{Q}{\Delta h} \quad (1)$$

Here, Δh (J/g) is the specific reaction enthalpy. The specific thermal power P (W/g) on the y-axis is proportional to the rate of reaction ν (g/s):

$$\nu = \frac{P}{\Delta h} \quad (2)$$

A problem with the use of these equations is that the reaction enthalpy Δh may have different values at different times of the hydration process. Apart from that, these relations are useful in modelling the cement hydration process as solid-state kinetic models usually have the form:

$$\nu = f(\xi) \quad (3)$$

This can easily be rewritten using the calorimetrically measured parameters P and Q [1,2]:

$$Q = f_2(P) \quad (4)$$

Data from a calorimetric measurement can therefore be used to test different kinetic models.

All calorimetric measurements worked well. The duplicates were close to each other and it is seen in Figures 4 and 5 that the reaction rate is not very much influenced by the water/cement-ratio. For both cements the hydration reaction continues longer for the highest w/c-ratio of 0.50. After three weeks the thermal power from these samples is still in the order of 100 μ W. For the other w/c-ratios the reaction rate is so low after two or three weeks that it is not measurable with the instruments used. The lower w/c-ratios seem to have a slightly higher rate of reaction at the maximal rate of reaction (main peak of curves).

We plan to continue the present type of measurements with the same calorimeter, but with another type of RH-sensors.

6. Conclusion

We conclude that the combination of isothermal calorimetry and relative humidity measurements is an interesting combination for the study of self-desiccating systems. However, great care must be taken to prevent leakages and sorption in sensors.

Acknowledgements

We thank Bo Johansson for the measurements.

References

- [1] Bensted, J., Some applications of conduction calorimetry to cement hydration. *Adv. Cement Res.*, **1**(1): 35-44 (1987).
- [2] Thermometric, TAM Air Cement, Järfälla, Sweden. (2002).
- [3] Penttala, V., Freezing-induced strains and pressures in wet porous materials and especially in concrete mortars. *Advn Cem Bas Mat*, **7**: 8-19 (1998).
- [4] Willson, R. J., A. E. Beezer, et al., Solid state reactions studied by isothermal microcalorimetry; the solid state oxidation of ascorbic acid. *Int. J. Pharmaceutics* **132**: 45-51 (1996).
- [5] Willson, R. J., A. E. Beezer, et al., Determination of thermodynamic and kinetic parameters from isothermal heat conduction microcalorimetry: applications to long-term-reaction studies. *J Phys Chem* **99** (7108-7113) (1995).