



# LUND UNIVERSITY

## Flow Systems

Åström, Karl Johan

1975

*Document Version:*

Publisher's PDF, also known as Version of record

[Link to publication](#)

*Citation for published version (APA):*

Åström, K. J. (1975). *Flow Systems*. (Technical Reports TFRT-7087). Department of Automatic Control, Lund Institute of Technology (LTH).

*Total number of authors:*

1

### General rights

Unless other specific re-use rights are stated the following general rights apply:

Copyright and moral rights for the publications made accessible in the public portal are retained by the authors and/or other copyright owners and it is a condition of accessing publications that users recognise and abide by the legal requirements associated with these rights.

- Users may download and print one copy of any publication from the public portal for the purpose of private study or research.
- You may not further distribute the material or use it for any profit-making activity or commercial gain
- You may freely distribute the URL identifying the publication in the public portal

Read more about Creative commons licenses: <https://creativecommons.org/licenses/>

### Take down policy

If you believe that this document breaches copyright please contact us providing details, and we will remove access to the work immediately and investigate your claim.

LUND UNIVERSITY

PO Box 117  
221 00 Lund  
+46 46-222 00 00

TFRT - 7087

## FLOW SYSTEMS

K J. ÅSTRÖM

Report 7531 (C) December 1975  
Department of Automatic Control  
Lund Institute of Technology

## FLOW SYSTEMS

K J Åström

Department of Automatic Control  
Lund Institute of Technology  
S-220 07 LUND 7, SWEDEN

### 1. INTRODUCTION

An attractive idea when investigating large systems is to mimic the success of statistical mechanics, i.e. to consider a large system composed of many copies of identical subsystems. A fundamental difficulty is that it is hard to find meaningful systemtheoretic problems which can be obtained by interconnecting identical subsystems. This paper therefore considers a class of linear systems called flow systems. Although the systems are not identical many of their properties remain invariant for different interconnections. Flow systems can therefore be used as a starting point for analysing certain large systems. Flow systems have been used as models for industrial and biological processes.

### 2. TANK SYSTEMS AND FLOW SYSTEMS

A collection of tanks connected by pipes is called a tank system. Such systems are common in industry. They have also been extensively used as models for biological and ecological systems. Tank systems are often explored by tracer analysis. A traceable substance, which propagates through the system in the same way as the fluid, is introduced at some point of the system. The tracer concentration at another point in the system is then measured. One key problem is to analyse what properties of a tank system that can be found from such an experiment.

Assume that the flows and volumes are in equilibrium, the tracer propagation can be described as a linear time invariant dynamical system. The dynamical systems describing tracer propagation

have, however, some special properties which motivates that they are given a special name flow systems. The impulse response of a flow system is non-negative which reflects the fact that the tracer concentration is never negative. Moreover, if the tanks system is open which means that all tanks are connected to an outlet (possibly indirectly through other tanks) all tracer will eventually leave the system. The corresponding open flow systems then have the property that the integral of the impulse response is unity.

Open flow systems will be investigated in this paper. They have many interesting properties which have largely been found in connection with impulse response analysis of tank systems. The results are widely scattered in literature. Important contributions are found both in engineering and medical literature. This paper is an attempt to present a unified approach.

Two simple examples corresponding to a tank with pure mixing and a tank with pure plug flow are first investigated. A formal definition of an open flow system is then given and interconnections of open flow systems are introduced. The so called Stewart-Hamilton equation which can be used to determine the total volume of an open tank system is then derived. The volume obtained is the part of the volume which participates in the flow also called the volume of distribution.

### 3. EXAMPLES

Two simple examples of flow systems will first be given.

#### EXAMPLE 1 (IDEAL MIXING)

Consider a tank with volume  $V$  and constant inflow and outflow  $q$  (volume flow). Assume that there is perfect mixing in the tank and that the fluid is not compressible. Let  $c_i$  be the concentration of a tracer in the inflow and  $c$  the tracer concentration in the tank and at the outflow. A mass balance for the tracer gives

$$V \frac{dc}{dt} = q(c_i - c)$$

The propagation of the tracer through the system can thus be described as a linear time invariant dynamical system whose input output relation is characterized by the impulse response

$$h(t) = (V/q)e^{-qt/V} \quad (1)$$

#### EXAMPLE 2 (PURE TRANSPORT OR PLUG FLOW)

Consider a pipe where there is a pure material transport with uniform velocity and no mixing. Let the volume of the tube be  $V$  and

the flow  $q$ . Let  $c_i$  denote the concentration of some substance in the inlet and  $c$  the concentration of the same substance at the outlet. The concentrations are related by

$$c(t) = c_i(t-V/q)$$

and the impulse response of the system becomes

$$h(t) = \delta(t-V/q) \quad (2)$$

where  $\delta$  is the Dirac delta function. The propagation of a tracer through a tank with ideal mixing and for a pipe with pure plug flow can be described by linear time invariant dynamical systems.

In both cases the impulse responses have the properties.

$$h(t) \geq 0 \quad (3)$$

$$\int_0^{\infty} h(t)dt = 1 \quad (4)$$

and

$$\int_0^{\infty} th(t)dt = -V/q \quad (5)$$

The equation (3) means that the tracer concentration is never negative and the equation (4) implies that all tracer will finally leave the system. If the impulse response is measured by injecting a tracer in the inlet and measuring the tracer concentration in the outlet the volume to flow ratio  $V/q$  can thus be determined from the equation (5) both for an ideal mixing tank and for a pipe with pure plug flow.

#### 4. AN AXIOMATIC APPROACH

The theory of flow systems will now be developed systematically. The analysis will be carried out for systems with one inlet and one outlet. There are, however, no difficulties to extend the results to more general situations. In analogy with the simple examples the systems will be characterized by their impulse responses. Introduce

##### DEFINITION 1

A single-input single-output time invariant linear system is called a flow system if the impulse response has the property (3). It is called an open flow system if the impulse response also has the property (4).

It follows from the previous examples that the transportation of a substance through a tank with perfect mixing and through a

pipe with pure mass transport without mixing can be described by flow systems.

Notice that the quantity

$$\int_{t_1}^{t_2} h(t) dt$$

can be interpreted as the probability that a particle entering the system at time 0 will exit in the interval  $(t_1, t_2)$ . The impulse response of a flow system can thus be interpreted as a probability density. It is, therefore, also called the residence time distribution or more correctly the density of the residence time distribution. The properties (3) and (4) are far reaching. A flow system is e g always input-output stable. To explore the properties further we analyse the transfer function  $H$  defined by

$$H(s) = \int_0^{\infty} e^{-st} h(t) dt \quad (6)$$

The equation (4) implies that

$$H(0) = \int_0^{\infty} h(t) dt = 1 \quad (7)$$

For  $\text{Re } s \geq 0$  we have

$$\begin{aligned} |H(s)| &= \left| \int_0^{\infty} e^{-st} h(t) dt \right| \leq \int_0^{\infty} |e^{-st}| h(t) dt \leq \\ &\leq \int_0^{\infty} h(t) dt = 1 \quad \text{Re } s \geq 0 \end{aligned}$$

The magnitude of the transfer function of a flow system is thus less than or equal to one in the closed right half plane.

Let  $\omega_k$  be arbitrary real numbers and  $x_k$  arbitrary complex numbers. Then

$$\begin{aligned} \sum_k \sum_{\ell} x_k \bar{x}_{\ell} H(i\omega_k - i\omega_{\ell}) &= \int_0^{\infty} \sum_k \sum_{\ell} x_k \bar{x}_{\ell} e^{i\omega_k t} e^{-i\omega_{\ell} t} h(t) dt = \\ &= \int_0^{\infty} (\sum_k x_k e^{i\omega_k t}) (\sum_{\ell} \bar{x}_{\ell} e^{-i\omega_{\ell} t}) h(t) dt = \\ &= \int_0^{\infty} \left| \sum_k x_k e^{i\omega_k t} \right|^2 h(t) dt \geq 0 \quad (8) \end{aligned}$$

It follows from a famous theorem of Bochner (1932) that the conditions (7) and (8) also imply (4) and (3).

An open flow system can thus also be defined as a linear time invariant system whose transfer function satisfies (7) and (8). This is not done because the conditions (3) and (4) are much more appealing to physical intuition.

#### 4. INTERCONNECTION OF FLOW SYSTEMS

There are several ways to interconnect flow systems. They can e g be connected in series, parallel or in feedback connections in the same way as ordinary linear systems are interconnected. More interesting and more useful results are, however, obtained if the interconnection is done in a different way. Since flow systems are used to describe the propagation of a tracer in a tank system we will first consider different ways to connect tanks together. Interconnection of flow systems will then be defined by considering the flow systems which describe the propagation of a tracer in the interconnected tanks.

Tanks can be connected in many different ways. The outflow of one tank can be sent to another tank (series connection). A flow can be split up in different parts which are sent through tanks and again continued (parallel connection). Part of the outflow of a tank can be mixed with the inflow and sent to the tank again (feedback connection).

It seems intuitively clear that if the tracer propagation in two tanks is described by flow systems in the sense of Definition 1, then the propagation of a tracer in the interconnected tanks is also a flow system. It will now be shown formally that this is indeed the case.

By a series connection of two tanks we mean the system obtained by letting the outlet of one tank be connected to the inlet of the other tank as illustrated in Fig 1.

Assume that the tracer propagation in  $S_1$  and  $S_2$  can be described by flow systems with the transfer functions  $H_1$  and  $H_2$ . Let  $c_i$ ,  $c_1$  and  $c$  denote the tracer concentrations at the inlet of  $S_1$ , the outlet of  $S_1$  and the outlet of  $S_2$  respectively. Then

$$C_1(s) = H_1(s)C_i(s)$$

$$C(s) = H_2(s)C_1(s)$$

Elimination of  $C_1$  gives

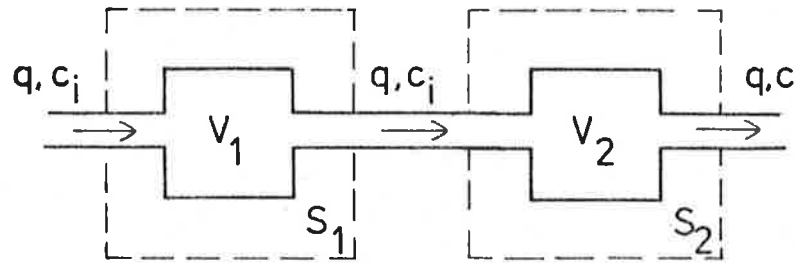

Fig 1. Series connection of the flow systems  $S_1$  and  $S_2$ .

$$C(s) = H_2(s)H_1(s)C_i(s)$$

and we thus find that the propagation of a tracer in a series connection of two tanks can be described by a linear system with the transfer function

$$H_s(s) = H_2(s)H_1(s) \quad (9)$$

To show that the transfer function  $H_s$  corresponds to a flow system we introduce the corresponding impulse responses, i e

$$h_s(t) = \int_0^{\infty} h_2(t-s)h_1(s)ds$$

It is clear that if  $h_1$  and  $h_2$  are non-negative then  $h_s$  is also non-negative. Furthermore it follows from (8) that

$$H_s(0) = H_2(0)H_1(0) = 1$$

Taking (9) as the definition of a series connecting of two flow systems it has thus been shown that the series connection of two flow systems is a flow system.

We will now proceed to other ways of connecting flow systems. A parallel connection of two tanks is obtained by splitting the inflow  $q$  into two flows  $\alpha_1 q$  and  $\alpha_2 q$  where  $0 \leq \alpha_1 \leq 1$  and  $\alpha_1 + \alpha_2 = 1$ . These flows are then taken as inflows to the tanks  $S_1$  and  $S_2$  whose outflows are then combined assuming perfect mixing. The parallel connection is illustrated in Fig 2.

To analyse the propagation of a tracer through two tanks  $S_1$  and  $S_2$  in parallel it is assumed that the tracer propagation through  $S_1$  and  $S_2$  can be described by flow systems with the transfer functions  $H_1$  and  $H_2$ . Let  $c_i$  denote the tracer concentration at the inlet and  $c_1$  and  $c_2$  the tracer concentrations at the outlets of the



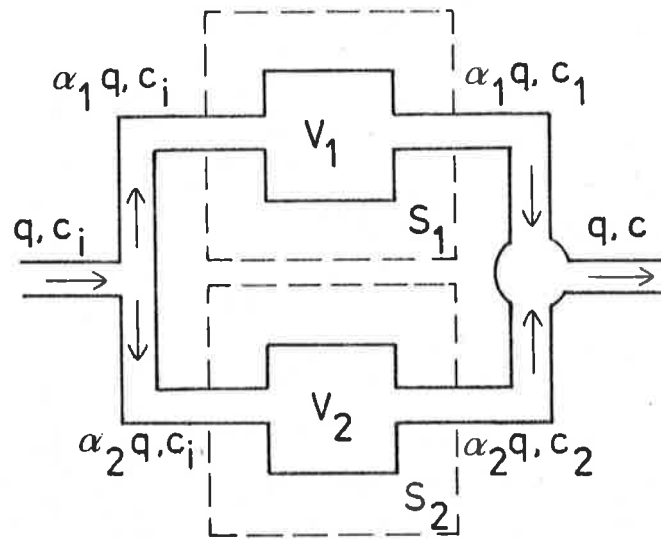

Fig 2. Parallel connection of the flow systems  $S_1$  and  $S_2$ .

tanks. Then

$$C_1(s) = H_1(s)C_i(s)$$

$$C_2(s) = H_2(s)C_i(s)$$

Since the output flow is obtained by ideal mixing of the flows  $\alpha_1 q$  and  $\alpha_2 q$ , with tracer concentrations  $c_1$  and  $c_2$ , the concentration at the outlet becomes

$$C(s) = \alpha_1 C_1(s) + \alpha_2 C_2(s) = [\alpha_1 H_1(s) + \alpha_2 H_2(s)] C_i(s)$$

The propagation of a tracer through a parallel connection of two tanks can thus be described by a linear system with the transfer function

$$H_p(s) = \alpha_1 H_1(s) + \alpha_2 H_2(s) \quad 0 \leq \alpha_1, \alpha_2 \leq 1, \alpha_1 + \alpha_2 = 1 \quad (10)$$

To verify that this is a transfer function of a flow system the impulse responses are introduced. Hence

$$h_p(t) = \alpha_1 h_1(t) + \alpha_2 h_2(t)$$

It is clear that if  $h_1$  and  $h_2$  satisfy (3) and (4), then  $h_p$  will also satisfy the same equations.

The feedback connection  $S_f$  of two tanks or two flow systems  $S_1$  and  $S_2$  is illustrated in Fig 3. Let the inflow to  $S_3$  be  $q$  and the tracer concentration  $c_i$ . Furthermore let the proportion  $\alpha$  of the outflow of  $S_1$  be the inflow to  $S_2$ . It is assumed that the outflow of  $S_2$  is perfectly mixed with the system inflow.

If  $\alpha q_1$  is the flow through  $S_2$ , a flow balance then gives

$$(\alpha q_1 + q) = q_1$$

Hence

$$q_1 = \frac{q}{1 - \alpha}$$

Let  $c_2$  denote the concentration at the outlet of  $S_2$  then

$$C_2(s) = H_2(s)C(s)$$

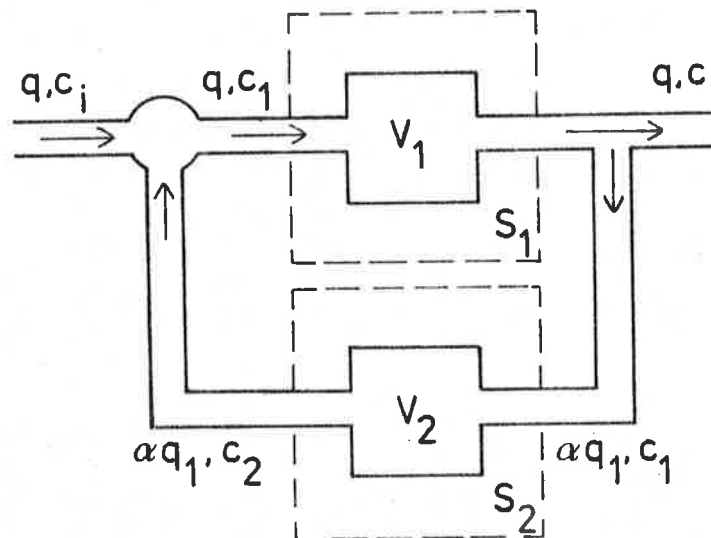

Fig 3. Feedback connection of the flow systems  $S_1$  and  $S_2$ . The inflow  $q$  is perfectly mixed with the outflow of  $S_2$ , and the mixture is fed to  $S_1$ . The outflow of  $S_1$  is split into two streams, one of which goes to  $S_2$  and the other part is the outflow of  $S_f$ .

The input to  $S_1$  is a mix of two flows  $q$  and  $\alpha q/(1-\alpha)$ , having concentrations  $c_i$  and  $c_2$  respectively. The concentration  $c_1$  at the inlet of  $S_1$  is thus

$$C_1(s) = (1-\alpha)C_i(s) + \alpha C_2(s)$$

Furthermore

$$C(s) = H_1(s)C_1(s) = (1-\alpha)H_1(s)C_i(s) + \alpha H_1(s)H_2(s)C(s)$$

which gives

$$C(s) = \frac{(1-\alpha)H_1(s)}{1 - \alpha H_1(s)H_2(s)} C_i(s)$$

The tracer propagation through a feedback connection of two tanks can thus be described by a linear system with the transfer function

$$H_f(s) = \frac{(1-\alpha)H_1(s)}{1 - \alpha H_1(s)H_2(s)} \quad 0 \leq \alpha < 1 \quad (11)$$

Assuming that  $H_1$  and  $H_2$  are transfer functions of flow systems it will now be shown that  $H_f$  is also such a transfer function. We have

$$H_f(0) = \frac{(1-\alpha)H_1(0)}{1 - \alpha H_1(0)H_2(0)} = \frac{1 - \alpha}{1 - \alpha} = 1$$

Furthermore introduce  $H = H_1H_2$ . Since  $S_1$  and  $S_2$  are flow systems, it follows from the equation (7) that

$$|H(s)| \leq 1 \quad \text{for } \text{Re } s \geq 0$$

The series expansion

$$H_f(s) = (1-\alpha)H_1(s)[1 + \alpha H(s) + \alpha^2 H^2(s) + \dots]$$

thus converges uniformly for  $\alpha \leq \alpha_0 < 1$  and  $\text{Re } s \geq 0$ . The corresponding impulse response then satisfies

$$h_f = (1-\alpha)h_1*[1 + \alpha h + \alpha^2 h*h + \dots]$$

where  $*$  denotes convolution. Since  $S_1$  and  $S_2$  are flow systems, we have  $h_1(t) \geq 0$  and  $h_2(t) \geq 0$ , and we find  $h_f(t) \geq 0$ .

Summing up we get

THEOREM 1

Let  $S_1$  and  $S_2$  be open flow systems with the transfer functions  $H_1$  and  $H_2$ . The series  $S_s$ , parallel  $S_p$  and feedback  $S_f$  connections of  $S_1$  and  $S_2$  whose transfer functions are defined by

$$H_s = H_2 H_1 \quad (9)$$

$$H_p = \alpha_1 H_1 + \alpha_2 H_2 \quad 0 \leq \alpha_1, \alpha_2 \leq 1, \alpha_1 + \alpha_2 = 1 \quad (10)$$

$$H_f = \frac{(1-\alpha)H_1}{1 - \alpha H_1 H_2} \quad 0 \leq \alpha < 1 \quad (11)$$

are then also open flow systems.

Remark. Notice that the series connection of two flow systems is identical to the series connection of two linear systems. The parallel and feedback connections of flow systems are, however, not the same as the parallel and series connection of linear systems.

Using Theorem 1 the propagation of a tracer through a tank system can be studied in the same way as signal propagation is analysed in an ordinary linear system.

## 5. THE STEWART-HAMILTON EQUATION

The analysis of the simple tank systems corresponding to a tank with ideal mixing in Example 1 and to a tank with pure plug flow in Example 2 shows that the following equation

$$\int_0^{\infty} th(t)dt = V/q \quad (12)$$

holds in both cases. Compare with the equation (5). Recalling the probabilistic interpretation of the impulse response  $h$  as the residence time distribution the equation (12) simply says that for a tank system with one inlet and one outlet the ratio of volume to flow equals the mean residence time. The equation (12) was first used by the physiologists Stewart (1897) and Hamilton (1932) who developed methods to determine the blood volume of the heart. The equation (12) will therefore be called the Stewart-Hamilton equation. The equation has been widely used both in biology, physiology and engineering. It has also been misinterpreted and therefore the cause of much controversy.

The equation (12) can be derived by the following heuristic

argument. Consider an open tank system with inflow  $q$ . The fraction  $h(t)dt$  of the particles which enter the system at time zero will exit in the interval  $(t, t+dt)$ . These particles have traversed the volume  $dv = t \cdot q$ . Integrating over all particles now gives (12). The validity of the equation (12) can also be shown formally in many cases. We have the following result:

**THEOREM 2**

Let  $S_1$  and  $S_2$  be tank systems with one inlet and one outlet and volumes  $V_1$  and  $V_2$ . Let the tank system  $S_3$  be a series, parallel or feedback connection of  $S_1$  and  $S_2$ . Assume that the Stewart-Hamilton equation holds for  $S_1$  and  $S_2$  then it also holds for  $S_3$ .

Proof. Let  $H_1$  and  $H_2$  be the transfer functions which characterize the tracer propagation in  $S_1$  and  $S_2$ . The different ways to interconnect the systems will be discussed separately.

First consider a series connection. It follows from Theorem 1 that the tracer propagation in  $S_3$  then is characterized by the transfer function  $H_3 = H_1 H_2$ . The mean residence time of  $S_3$  is then given by

$$\begin{aligned} \int_0^{\infty} t h_3(t) dt &= -H_3'(0) = -H_1'(0)H_2(0) - H_1(0)H_2'(0) = (V_1 + V_2)/q = \\ &= V_3/q \end{aligned}$$

The third equality follows from the fact that the flows through  $S_1$  and  $S_2$  are the same in a series connection.

Now consider a parallel connection. See Fig 2. Since the flow through  $S_1$  is  $\alpha_1 q$  and that through  $S_2$  is  $\alpha_2 q$ , we get

$$-H_1'(0) = V_1/(\alpha_1 q) \quad \text{and} \quad -H_2'(0) = V_2/(\alpha_2 q)$$

The mean residence time of  $S_3$  is given by

$$\begin{aligned} \int_0^{\infty} t h_3(t) dt &= -H_3'(0) = -\alpha_1 H_1'(0) - \alpha_2 H_2'(0) = (V_1 + V_2)/q = \\ &= V_3/q \end{aligned}$$

and the result is thus established also for a parallel connection.

For a feedback connection, Fig 3, the flow through  $S_1$  is  $q_1 = q/(1-\alpha)$  and the flow through  $S_2$  is  $\alpha q_1 = \alpha q/(1-\alpha)$ . Hence

$$\begin{aligned} -H_1'(0) &= V_1/q_1 = (1-\alpha)V_1/q \\ -H_2'(0) &= V_2/(\alpha q) = (1-\alpha)V_2/(\alpha q) \end{aligned}$$

The equation (10) gives

$$H_3' = \frac{(1-\alpha)H_1'}{1 - \alpha H_1 H_2} + \frac{(1-\alpha)H_1(\alpha H_1' H_2 + \alpha H_1 H_2')}{(1-\alpha H_1 H_2)^2} = \frac{(1-\alpha)(H_1' + \alpha H_1^2 H_2')}{(1-\alpha H_1 H_2)^2}$$

The mean residence time is then given by

$$\int_0^{\infty} t h_3(t) dt = -H_3'(0) = -\frac{1}{1-\alpha} H_1' - \frac{\alpha}{1-\alpha} H_2' = (V_1 + V_2)/q = V_3/q$$

and the proof is now complete.

Remark 1. Combining Theorem 2 with the results of Example 1 and Example 2, it is thus found that the Stewart-Hamilton equation holds for systems which are obtained by series, parallel or feed-back connections of simple flow systems with pure transport or with ideal mixing.

Remark 2. The Stewart-Hamilton equation has been derived only for systems which are open flow system. Internal recirculations are allowed provided that only a fraction of the flow is recirculated ( $\alpha < 1$  in Theorem 1). All fluid particles must, however, sooner or later leave the system, or formally the equation (4) must hold. This will not be the case if all the flow is recirculated.

## 6. REFERENCES

- Andersson, B J (1957): "Studies on the circulation in organic systems with applications to indicator methods". Trans Roy Inst of Technology, No 114 (1957), Stockholm, Sweden.
- Bochner, S (1932): "Vorlesungen über Fouriersche Integrale". Leipzig 1932.
- Danckwerts, P V (1953): "Continuous flow systems". Chem Eng Sci 2 (1953) 1-13.
- Hamilton, W F, Moore, J W, Kinsman, J M, Spurling, R G (1932): "Studies on the circulation". Am J Physiol 99 (1932) 534.
- Sheppard, C W (1962): "Basic principles of the tracer method". John Wiley, New York 1962.
- Stewart, G N (1897): "Researches on the circulation time and on the influences which affect it". J Physiol 22 (1897) 159-183.