



LUND UNIVERSITY

Fire Safety Risk Analysis of a Hotel

Frantzich, Håkan

1997

[Link to publication](#)

Citation for published version (APA):

Frantzich, H. (1997). *Fire Safety Risk Analysis of a Hotel*. (LUTVDG/TVBB--3091--SE; Vol. 3091). Department of Fire Safety Engineering and Systems Safety, Lund University.

Total number of authors:

1

General rights

Unless other specific re-use rights are stated the following general rights apply:

Copyright and moral rights for the publications made accessible in the public portal are retained by the authors and/or other copyright owners and it is a condition of accessing publications that users recognise and abide by the legal requirements associated with these rights.

- Users may download and print one copy of any publication from the public portal for the purpose of private study or research.
- You may not further distribute the material or use it for any profit-making activity or commercial gain
- You may freely distribute the URL identifying the publication in the public portal

Read more about Creative commons licenses: <https://creativecommons.org/licenses/>

Take down policy

If you believe that this document breaches copyright please contact us providing details, and we will remove access to the work immediately and investigate your claim.

LUND UNIVERSITY

PO Box 117
221 00 Lund
+46 46-222 00 00

Brandteknik
Lunds Universitet



Department of Fire Safety Engineering
Lund Institute of Technology
Lund University

Report 3091

Fire Safety Risk Analysis of a Hotel

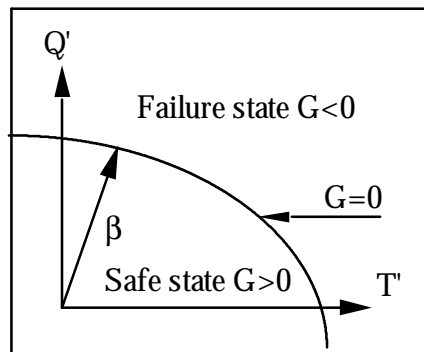

Håkan Frantzich

The report has been financed by the Development Fund of the Swedish Construction Industry, Svenska Byggbranschens Utvecklings Fond (SBUF)

Lund February 1997

ISSN 1102-8246

ISRN LUTVDG/TVBB-3091-SE

The report has been financed by the Development Fund of the Swedish Construction Industry, Svenska Byggbranschens Utvecklings Fond (SBUF), project No. 2123

Keywords: Risk analysis, FOSM method, fire, evacuation, reliability index, hotel

Abstract: The first order second moment (FOSM) method is used for deriving a risk measure for safety of people in hotels. The measure is the reliability index β . The safety is expressed as the evacuation time margin which is the difference between the available time before untenable conditions occur and the evacuation time. These times are subjected to uncertainty. The reliability index is used to determine the probability that the escape time margin will be negative. The influences on the reliability index from different escape alarm systems and smoke detection systems are investigated. Two risk definitions are described. Risk is defined for the guest in the fire room and for the other guests on the floor of the fire. Only fires in a guest room are considered. A traditional risk analysis is also performed to determine the influence of the floor plan size and the type of escape alarm on the safety level.

© Copyright Institutionen för brandteknik
Lunds Tekniska Högskola, Lunds Universitet, Lund 1997

Omslag: Håkan Frantzich

Layout: Håkan Frantzich

Illustrationer/Diagram: Håkan Frantzich

Department of Fire Safety Engineering · Lund Institute of Technology · Lund University

Adress/Address	Telefon/Telephone	Telefax	E-post/E-mail
Box 118 /John Ericssons väg 1	046 - 222 73 60	046 - 222 46 12	
SE-221 00 LUND	+46 46 222 73 60	+46 46 222 46 12	Hakan.Frantzich@brand.lth.se

List of contents

	Summary	5
	Acknowledgements	8
1	Introduction	9
2	Hotel building	12
3	The choice of parameters	14
3.1	Probability of fire occurrence	14
3.2	Uncertainty variables	14
4	Definition of risk	17
4.1	Individual risk	18
4.2	Societal risk	18
5	Risk methods	20
5.1	Limit state function	20
5.2	Individual risk method	22
5.3	Event tree description	24
5.3.1	Event sequences	25
5.4	Societal risk method	27
5.5	Individual risk presentation technique	28
6	Fire safety calculations	33
6.1	Untenable conditions	33
6.2	Fire specifications	33
6.3	Time to untenable conditions	34
6.3.1	Room of fire origin	35
6.3.2	Corridor	35
6.3.3	The other rooms	36
6.4	Model uncertainty	36
6.5	Active systems	37
6.6	Detection time	38
6.7	Investigation time	38
6.8	Guests	39
6.9	Movement time	39
7	Result	41
7.1	Reliability index	42
7.2	Importance of variables	46
7.3	Design value of α	47

7.4	Sensitivity analysis	48
7.5	Societal risk	50
8	Conclusion	56
9	Limitations	58
10	Future work	59
11	References	60
Appendix A		

Summary

A First Order Second Moment (FOSM) method has been used to derive a measure for evacuation safety, for people in hotel rooms. The safety measure used is the reliability index β . It represents the individual risk, due to fire, subjected to a guest visiting the hotel. The derived β -value can be interpreted as a value of safety, on the condition that a fire has started. The evacuation is described by the escape time margin for the last person leaving the threatened area. The escape time margin, expressed by the limit state function, is the difference between the available time and the evacuation time. By subjecting some variables, in the limit state function, to uncertainty the reliability inherent in the function can be determined. The reliability index β is a measure of this uncertainty and it can be used to estimate the probability that the escape time will exceed the available time i.e. the risk.

The reliability index can be used to compare design solutions having different installations, such as escape alarm and automatic fire alarm. These installations affect the total safety level. If a fire alarm system is out of order, the probability of having a successful evacuation will be reduced.

Also the risk to the society has been investigated by deriving the risk that more than one person will be affected by the threat. The individual risk is defined for the last person leaving the area. The societal risk considers the number of persons affected at the time when the situation becomes untenable. The risk is expressed in terms of number of affected persons and the related probabilities for unsuccessful evacuation, an F-N-curve. Calculations have been performed on four different design alternatives by combining two corridor lengths and two types of escape alarm systems.

The scenarios have been organised by an event tree approach. The branch points answer the questions:

- is the guest awake?
- is there a fire alarm in the hotel?
- is there a direct smoke detector alarm to the fire room?
- what type of escape alarm signal is present?
- is the door to the corridor from the fire room open?

Each combination of choices, at the event tree branch points, will result in a scenario.

The reliability index is calculated for two locations in the hotel, the fire room and the corridor. The corridor is chosen as the guests in the other rooms have to pass

the corridor in their way to the safe location. The societal risk considers the whole hotel floor at the same time.

It is always assumed that the guests are evacuating. The alternative is to stay in the room and wait for rescue. This event is not examined. The safety level in the fire room is highly depending on if the guest is awake or not. If the guest is asleep the safety is depending on if there is a direct alarm signal in the room or not. The direct alarm is assumed to start as soon as the fire is detected by the smoke detector. A traditional home smoke detector is an example of this type of alarm. The alarm is only heard in the room of fire. If these conditions are not met the safety level is drastically reduced for the guest in the fire room.

The safety level for the guests staying in the other rooms is depending on the type of alarm signal notifying of the fire. Two types of escape alarm signals have been considered. A traditional alarm bell located in the corridor has been compared to an improved alarm system where the alarm signal appliance is located in each guest room. The response time for the guest after hearing the alarm is depending on the type of alarm. It is assumed that the traditional alarm bell results in twice the response time compared to the improved alarm. The improved alarm consists of a tone signal and a flashing light. As the response time is shorter for the tone alarm this results in a higher safety level. The benefit of having an escape alarm is on condition that an automatic fire alarm detects the fire. If no automatic detection is installed, the safety level for the guests on the floor is reduced. This safety level is derived by assuming a conservative manual detection time. For these conditions the guests might be more safe staying in their rooms waiting for help.

The calculations of the reliability index for the neighbouring guests on the floor always assume that the door to the fire room is kept open. This is an uncertain assumption. Doors in hotels in Sweden are normally equipped with a closing device. In deriving the societal risk the probability that the door is left open or the closing device is out of order, considered in the resulting F-N-curve.

The calculations of reliability have been performed by the program STRUREL. It calculates the reliability index, importance measures et c., when the variable distributions are known. The parameters describing these variables are mostly chosen according to judgement based on experiments and statistics. In the calculations each distribution is described with its mean and standard deviation. The data for deriving the risk to the society have been achieved from the computer package @RISK. This program is a Monte Carlo simulation tool which produces data to the estimated distributions for the basic variables. This information can be used for deriving the distributions for the variables, as time to untenable conditions, in the limit state function.

The program CFAST has been used for the calculation of time to untenable conditions in the rooms and in the corridor. The results from CFAST have been fitted to a response surface predicting the time to untenable conditions as a function of the growth rate of the fire. It was created by using the method of least squares. The response surface is used in STRUREL instead of the actual CFAST output. The reason for this procedure is to reduce the computation time. The fire specified in CFAST follows an αt^2 relationship. The variable α determines the uncertainty in fire scenario consequences. A variable addressing the model uncertainty has been incorporated for the CFAST results.

If the fire is detected by a smoke detector, the response time is calculated with the program Detact-t2. A response surface is created for the detection time in the same manner as for the time to untenable conditions. This means that the detection time will be depending on the fire growth rate.

After the guests have been notified of the fire, they are assumed to start evacuating after a response time. The response time is chosen according to the type of escape alarm present, as mentioned above. The movement times, to reach a safe location, are valid for a large population group as the variable covers both people with high and low walking velocity. Even elderly people with walking disabilities are considered.

The resulting individual risk i.e., the β -values are presented in two ways. First, the β -values corresponding to each of the scenarios, are displayed. In this way different safety strategies can be evaluated as the β -values can easily be compared. To be able to consider the reliability of the installed systems in the evaluation the second presentation method can be used. Now, the β -values and branch probabilities are combined in one figure illustrating the consequences if for example the fire alarm fails to operate. The probability for this event is used together with the relevant β -values. This results in a presentation technique which is similar to an F-N-curve used to present the societal risk. The consequences are represented by the β -values and the cumulative values for the branch probabilities. The curve shows how the safety for a specific hotel is affected by the branch probabilities in the event tree, i.e. for example the reliability of the installed systems. One should be aware of that it is still the individual risk levels that are used by this presentation technique.

The work results in some general conclusions regarding the safety for guests in hotels.

The door between the guest room and the corridor is important. If that door can be kept closed during a fire in the room, no untenable conditions will occur in the corridor. It is therefore important to maintain the fire separating ability of the door and to secure the operation of the door closing device.

The ability to detect the fire by an automatic fire alarm is essential for the safety. A fast detection time will increase the time available for evacuation. The automatic fire detection is necessary if the person in the guest room on fire shall be able to escape. For this persons safety a direct alarm signal must be provided in the for that room. The signal must start as soon as the fire is detected.

A escape alarm with two different alarm signal types will result in a higher safety level. This is, however, a result from the choice of parameters for the variable. The other type of alarm signal, an alarm bell, results in a lower safety level.

The choice of untenable conditions does not affect the overall safety level considerably. An increased reliability index is achieved when the untenable levels are increased but not very much.

The fire growth variable α is the most important variable. This has to do with the large uncertainty connected to this variable.

Future work should involve a systematic organisation of data concerning the fire development in rooms, the reliability of fire precaution systems, the likelihood of fire occurrence and the responses to escape alarms for the guests in hotels. This work should be focusing on reduction of the uncertainty of these variables.

As the work is subjected to some practical limitations, future work should try to address these to get a more complete picture of the safety level in hotels. The type of limitations are for example;

neglecting fire spread along the facade as a result of a fully developed fire in the guest room and

the fire and smoke spread through the ventilation system and

by only looking at a fire scenario located in a guest room.

Acknowledgements

This work has been financed by the Development Fund of the Swedish Construction Industry, Svenska Byggbranschens Utvecklings Fond (SBUF), which is gratefully acknowledged. The report is part of a series where the other reports consider safety in public assembly rooms and health care facilities.

1 Introduction

Luckily, hotel fires are rare events although they still happen. When fires occur in hotels, smoke is usually the main contributor to the increase of hazard to people. It is therefore, important to be able to predict both the smoke transport in the hotel and the risk to humans staying in the hotel. To derive the risk to humans, the fire consequences have to be defined. The objective with this report is to calculate the individual risk to people staying in hotels and to introduce a way to present this information so that the likelihood of the evacuation event is also addressed. The term risk is defined as the probability of not being able to escape before the conditions are untenable in the location of interest. The individual risk does only concern the risk level in the hotel, independent of the number of people subjected to the hazard. The societal risk takes the number of persons into consideration in presenting the risk. Therefore, both methods for defining risk are presented.

If a fire occurs in a hotel, the guests should be evacuated as fast as possible. This is usually the first strategy for the management and the fire brigade. An other alternative is to have the guests staying in their rooms for some time, waiting for the fire brigade to extinguish the fire. The guests shall be safe staying in the rooms, as each guest room in a hotel is a separate fire compartment.

However, as some recent fires developed, this might not be the best solution for the guests, Bryan (1983) and DBE (1987). These two references describe the fire consequences of the fires in MGM Grand Hotel in Las Vegas and Hotel Caledonien in Norway. In both cases smoke entered the guest rooms where people were staying. In the Norwegian hotel fire almost all fatalities were found in their rooms. The investigated strategy in this report is therefore assuming that the guests are leaving their rooms as soon as they have been alerted of the danger and have responded to the cues.

The risk is derived for the guest in the room of fire origin and for the guests trying to escape through the corridor leading to the safe location. The individual risk is derived for two locations, the fire room and the corridor. The neighbouring guests are initially staying in their rooms. The safe location is represented by the staircases, which are located in both ends of the corridor. Rooms are assumed to be present on two sides of the corridor. Two different corridor lengths are used for the calculations. This type of standardised floor configuration is used to reduce the number of variables subjected to uncertainty. The chosen dimensions of the floor are representative for hotels in Sweden.

The risk to people in the neighbouring rooms is derived as the risk subjected to them leaving the room and entering the corridor. This means that no risk will be present to them as long as they are staying in their rooms. This simplification is

made as the calculation show that no untenable conditions arise in the neighbouring room. This simplification can be questioned as for example wind pressure can force the fire smoke in a building to travel through unexpected routes. The wind pressure can force smoke to enter through leakage areas around the closed smoke proof door and create untenable conditions in room not directly exposed to the fire. However, the occurrence rate of such a condition can perhaps be considered low.

The individual risk is defined by the reliability index β . The reliability index is calculated using a limit state function defining the escape time margin. The same escape time margin is used for deriving the data for the societal risk. The difference is the treatment of the calculated data, see section 5.4. Having variables in the limit state function which are subjected to uncertainty, there might be situations where the time available is less than the time needed to perform the evacuation. The reliability index can be used to quantify the probability of negative escape time margin. The limit state function is generally expressed as

$$G = t_a - t_e \quad (1)$$

where t_a is the available time derived by the smoke transport model and t_e is the escape time also including time of detection and behaviour and response.

The technique of deriving the reliability index β is briefly presented in section 5.2. An approximate relationship exists between the β -value and the probability of having a unsuccessful evacuation i.e. the probability of failure p_f . The term unsuccessful is here used in the sense of having a negative escape time margin. The probability can be derived as

$$p_f \cong 1 - \Phi(\beta) \quad (2)$$

where Φ is the standardised normal function. The reliability index β is therefore a measure of success, the higher β -value, the more reliable evacuation can be expected. Using the method of describing the safety in terms of β -value is maybe not the best for all situations. Other risk analysis methods have been developed for chemical industries or nuclear power plants, CPQRA (1989). The main advantage by using this method is that it provides the design point, which is a combination of the design variables which has the highest probability of failure. This is the combination of the variables producing the worst situation, and the one which should be used for designing the escape routes. This information is valuable when design parameters shall be derived. Design parameters can be rate of energy release, time for response and behaviour and movement time for various situations.

This report is part of a series where the other reports consider safety in public assembly rooms, Magnusson et al. (1995) and health care facilities, Frantzich (1996).

2 Hotel building

The calculations are performed on one floor in a multi-level hotel. It is assumed that the guests can evacuate without any assistance from other guests or the hotel staff. The duties of the staff is restricted to start the escape alarm when the fire has been detected by an automatic fire alarm or is detected manually. The escape alarm is initiated after the staff have investigated the reason for the alarm. After the alarm, the guest respond to the alarm signal and after a while start to evacuate. It is therefore assumed that the hotel is manned around the clock and that the staff is familiar with the procedures during a fire.

Each guest room has a floor area of 65 m^2 and a height to the ceiling of 2.4 m. The room has a window, $0.90.9 \text{ m}^2$, to the outside and a door, $1.02.0 \text{ m}^2$, leading to the corridor. Each room is a separate fire compartment and the resistance time is one hour to the next room and to the corridor. The door to the corridor has a 30-minute rating. The door is equipped with a closing device which shall close the door after passage.

The door is assumed to open into the guest-room. Even if the door is fire rated some leakage areas will always be present. Leakage openings of $0.0052.0 \text{ m}^2$ at the side and $1.00.01 \text{ m}^2$ under the door are assumed for the simulation. The window is assumed to have a leak opening to the outside of $0.90.01 \text{ m}^2$.

Two types of floor configurations have been used, differing in length. The corridor lengths are 30 m or 60 m. The corridors are 3 m wide and 2.5 m high. The number of guest rooms are also determined by the length of the corridor, 12 or 24 rooms. The latter corridor length corresponds to the maximum allowed length according to the Swedish Building Code, BBR94 (1994). It is stated that the maximum allowed distance in the escape route to a stair or to the outside is 30 m.

The walls and ceiling are covered by gypsum sheets applied on non-combustible material and the floor is constructed of concrete. The gypsum sheets are rated in the highest performance class.

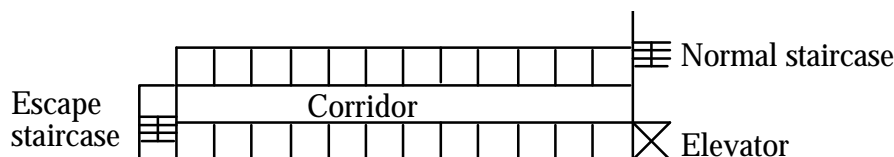

Figure 1. Principal layout of the floor.

In both ends of the corridor it is assumed that staircases leading to the ground floor are present. The doors leading to the staircases are assumed to be closed. They will, however, be opened during evacuation, letting smoke and people out to the staircase. To simulate this, these doors will be kept open during the whole simulation with an area of 0.12.0 m (WH). This is an engineering assumption which also makes the fire calculations easier. The staircases are assumed to be a place of safety.

It is further assumed that there is one guest in each room and that no queuing occurs at the staircases leading to the ground floor. When the reliability index, for the individual risk, is derived, the number of guests on the floor is irrelevant as the safety is affecting the last person to leave the location of interest. Deriving the risk of multiple affected people, the number must of course be part of the calculation. As the number of guests on the floor is limited it is assumed that the arrival rate at the staircases is one guest every four seconds. This rate is determined by the distance between the rooms and not by the flow capacity at the doorway. This information is needed to calculate the number of guests not yet in safety when the escape time margin is less than zero.

3 The choice of parameters

3.1 Probability of fire occurrence

To be able to make a risk estimation which can be compared to other risks in the society the probability of fire occurrence must be known. This information is, however, rather difficult to obtain as the number of fires in hotels are few. The information about fires in hotels are usually limited to register the total number of fires. What is lacking is the total number of hotels in the same region covered by the statistics. In this work the probability of fire occurrence is furthermore detailed as it is expressed as the number of fires per year and 100 rooms. To obtain the initial probability also the number of rooms for the hotels in the region must be known.

The statistics used in the present calculations have been collected from one community in Sweden, the city of Helsingborg. This reduces the generality of the statistics as only one community is covered. This should be kept in mind when the results are further discussed.

The number of hotel fires in Helsingborg over a time period of 7 years was 5 fires. The number of hotel rooms in Helsingborg was 1431 rooms as an average value. This results in a probability of fire equal 0.05 fires/(year 100 rooms). The fires considered are those which might lead to a total evacuation of the floor. Only fires reported to the fire department are covered in these statistics. As many hotels are equipped with an automatic fire alarm system, the fire department are notified of almost all hotel fires. Therefore, the statistics used are a good estimate of the true fire occurrence probability. The probabilities which are used in the calculations are 0.006 fires/year for the 30 m corridor and 0.012 fires/year for the 60 m corridor. It is further assumed that a fire on one floor is independent of the activities on other floors. This means that the number of floors of the hotel is not relevant to the safety for the guests. It also implies that the only persons affected by a fire are those staying on the fire-subjected floor. All other floors are safe. This is a simplification that has to be treated if a full safety analysis is to be performed.

3.2 Uncertainty variables

Some variables, the basic variables, are subjected to uncertainty. One way to describe the uncertainty is to use the probability density function or frequency distribution for the variable. The basic variables are those that are used in the limit state function, for example detection time, reaction time by staff and fire growth rate of the fire. The distribution shows the values that the variable can be assigned and how often the values are to be expected. The actual value of a basic variable is chosen by random from the distribution and the basic variable is therefore a random variable. The distributions are defined by the parameters

mean and standard deviation. These are the two parameters that have to be chosen for the risk calculations. Also the type of distribution has to be chosen.

The actual parameters describing the distributions for the basic variables are chosen according to

- experimental data and statistics
- judgement made by experts

For most variables, little systematic information is available that can provide guidance on how to choose parameters for the distributions. Experiments can lead to the choice of some parameters but the basis for choosing a specific value as the mean or standard deviation has not been systematically put together. The overall experimental database is very large but not easily accessible. There is no easy way to obtain the parameters from the experimental database. It is therefore necessary to estimate the parameters mostly by judgement and choose distribution types on basis of what has the highest degree of belief, Haimes et al. (1994). This estimation procedure for the parameters, the use of expert opinion, are quite common in other engineering fields, such as in the chemical process industry, when experimental data are lacking, CPQRA (1989).

For most types of input data, such as fire growth rate, there exists a more or less extensive data base, which provides a credible range (minimum values to maximum values) for the specific parameter. As a first step, a rectangular shape can be used to describe the variable distribution. Knowing the outer limits of the variable, the mean and standard deviation can easily be calculated. For other cases, the available data might be large enough to provide the most frequent value as well. A triangular distribution is the next approximation of the real distribution.

Actually, it does not matter so much if not the exact distribution type is used for each variable. It is usually not even possible to achieve that in practice. The resulting distribution is not very sensitive to the choice according to the central limit theorem. The most important information is concerning the parameter values, mean and standard deviation. The parameters are to a high degree chosen using a combination of experimental data, statistics and expert judgement. Collecting and systematically organising the relevant data must be a task given high priority in future work. This statement is also true for the probability of fire occurrence, described in the previous subsection.

The most frequent distribution type used in this report, is the normal distribution. It has been used for variables like time for investigation after the alarm signal and movement time of occupants. It is believed to represent the variables in a proper way. A log-normal distribution is chosen for the fire growth

rate as it provides no negative values and is believed to represent the variable in the best possible way. The parameters for the fire growth rate distribution are chosen according to findings from experiments and post fire investigations in hotels. The mean value of the fire growth rate is chosen to represent a likely level of the parameter. The standard deviation is chosen by judgement to be in the same order of magnitude. Only a few post fire investigations have been studied and the base for these choices is limited. The other distribution parameters are more or less chosen according to judgement. The choices have been discussed among other experts.

4 Definition of risk

Before introducing different risk methods it is necessary to define what is meant by risk. The risk associated with fire in a building takes into account the likelihood of fires and their potential consequences, e.g. the potential number of deaths. Hence it is possible to define risk as a function of hazard, probability and consequences:

$$\text{Risk} = f(\text{hazard, probability, consequence})$$

When calculating the risk associated with a particular hazard it is more common to write:

$$\text{Risk} = \Sigma (\text{probability consequence}), \text{ for all consequences.}$$

The risk can be expressed in monetary unit/year if a fire loss consequence in average is X units and the probability of a fire is Y% per year or in number of deaths per year in a building. But risk is not always simply the multiplication of two quantities, i.e. a numerical value. There is a distinction between the calculated risk and the perceived risk. The latter is important when it comes to answering the question about what is the acceptable risk. An important aspect is the degree of voluntariness with which the decision is taken and the risk is endured. The person who is making a decision weighs the risk against the advantages of the activity. The person might do the activity voluntarily and is therefore likely to accept a little higher risk for example when climbing mountains. The focus for this report will be on risk as a quantitative measure. Also here, a distinction in risk can be made, by dividing the risk in the categories individual risk and risk to the society. Other methods are available for measuring risk, for example average individual risk and fatal accident rate (FAR), CPQRA (1989), Covello et al. (1993).

The structured method used in performing an analysis where risk is a result, is usually called probabilistic risk analysis, abbreviated PRA. Risk analysis is a part of the risk assessment, which also includes the risk evaluation. Risk evaluation is the process in which judgements are made on the tolerability of the calculated risk. Risk management is the overall process in which also a process of controlling the risk is included together with the risk assessment, CEI (1995). Other definitions of risk analysis, risk assessment and risk management exist, Covello et al. (1993), which might be confusing. This report is purely devoted to risk analysis which is defined as Systematic use of available information to identify hazards and to estimate the risk to individuals or populations, property or the environment, CEI (1995). A similar approach is found in CPQRA (1989) where risk analysis is defined as The development of a quantitative estimate of

risk based on engineering evaluation and mathematical techniques for combining estimates of incident consequences and frequencies.

4.1 Individual risk

The individual risk is defined as the probability that a person will be affected by the unwanted consequence. If a person is located in the hazardous position the risk will affect him or her. The risk is calculated for each location, which in this case is two, the patient room and the corridor. The risk is independent of the number of persons affected by the consequences. The individual risk is the result from the calculations presented in this report. The risk is expressed as both the reliability index β and the probability that the unwanted event will occur. The evacuation conditions can change depending on the circumstances, for example if doors are open or if a detection system is failing. The different scenarios are structured by using an event-tree, see section 5.3.

4.2 Societal risk

The societal risk considers the risk of multiple fatality fires. In this case, not only the probability of the unwanted event is considered but also the number of persons subjected to the hazard. Simplified, it can be said that the societal risk is the individual risk for a specific location, multiplied with the number of persons on that location. This is repeated for every location. The results are sorted by increasing consequence. The risk is often described by the exceedance curve of the probability of the event and the consequences of that event in terms of number of deaths. This curve is known as the frequency-number-curve or F-N-curve, see figure 2. The curve shows the probability that consequences are worse than the value on the x-axis. This means that the risk is not constant in terms of number of deaths and the probability of those deaths. The society is less willing to accept a large number of deaths happening at the same time compared to the same number of deaths happening in a number of accidents. This risk measure is usually derived by using a numerical Monte Carlo sampling procedure.

The societal risk is calculated for the scenarios described by the event-tree. An approximate method for the societal risk is also presented which uses information from the individual risk calculations. This approximation of the real societal risk is on the conservative side. The reason is that the number of persons subjected to the hazard is not constant. Persons are evacuated out from the hazardous area. This means that the number of persons used to derive the societal risk is less than the originating number for the location. The risk calculation method used cannot be used to predict the exact number of persons not able to be evacuated, therefore the approximation. The risk to the society is further elaborated in sections 5.3 and 5.4 when introducing the event tree method.

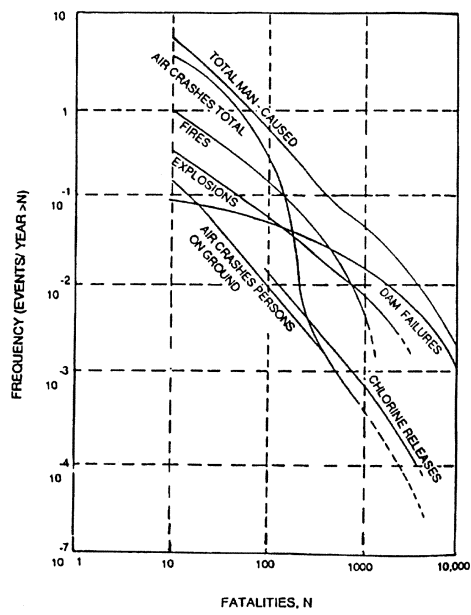

Figure 2. Example of F-N-curves for some risks, CPQRA (1989)

5 Risk methods

5.1 Limit state function

Safety is described by the margin of escape time. When a fire occurs there is a certain time available before the room is untenable for humans. By comparing the time available to the time needed, the margin is calculated as

$$G = t_a - t_e \quad (1)$$

G = escape time margin

t_a = available time

t_e = evacuation time

This equation is referred to as the limit state function. In the safe state the margin is positive. In the present case the available time is determined by the interaction of the fire and of the building. Energy release rate of the fire and opened or closed doors are factors affecting the available time. The evacuation time is the sum of detection time, investigation time, behaviour and response time and movement time.

The times t_a and t_e , are in their turn composed of basic variables that can be constants or subjected to uncertainty, random variables. These random variable distributions are described with an expected value and a deviation from the expected value, i.e. mean and standard deviation. Using random variables in the limit state function, results in a corresponding distribution of the margin.

The available time is expressed as

$$t_a = S \cdot U_s \quad (3)$$

and the evacuation time in general as

$$t_e = D + t_{Inv} + R + E \quad (4)$$

resulting in the limit state function

$$G = S \cdot U_s - D - t_{Inv} - R - E \quad (5)$$

S time to untenable conditions (calculated)

U_s model uncertainty factor for CFAST (random variable)

D detection time (calculated or random variable)

t_{Inv} investigation time by staff after alarm (random variable)

- R response time for the guest (random variable)
- E movement time for guest (random variable).

The actual components in the limit state function may vary depending on the scenario, but the general appearance is as above. The equations used for the scenarios are presented in appendix A together with a summary of the basic variables. The calculated variables are functions of other random variables such as the fire growth rate, α , and walking time by guests.

It should also be noted that there are variables in the calculations that are not subjected to uncertainty i.e. deterministic or constant values. Some of those are in fact subjected to uncertainty which has been neglected in the risk calculations. The number of random variables have been limited due to the following reasons.

- Not all variables subjected to uncertainty will affect the final result to a degree that is detectable. The uncertainty in the resulting safety measure is mostly determined by those variables, in the limit state function, having the highest level of uncertainty. By adding a new variable, subjected to uncertainty, to the existing ones will always increase the total uncertainty. Every new uncertainty variable adds to the total uncertainty. Even for the simple example

$$Z = X - Y$$

the variance of $Z = \text{Var}(X) + \text{Var}(Y)$, if Z , X and Y are random variables. But variables known with higher degree of precision will not substantially affect the overall uncertainty as their variances are low. The standard deviation, used to measure the uncertainty, is the square root of the variance. Finding important variables can be done by screening methods, IAEA (1989).

In this case the most significant uncertainty variables have been chosen by judgement. Examples of unimportant variables are size of leakage openings between the guest room and the corridor and the number of guests in a corridor. Some of these variables are implicitly considered in the overall uncertainty of the used random variables.

- As the dimensions of the floor are treated as constants, the influence of these are not possible to reveal. The dimensions are otherwise variables which can have a significant influence on the result. The dimensions are, however, chosen to represent an average hotel floor.
- Response equations, see section 6.3, which are used to replace time consuming computer calculations, must be derived using sets of all possible variable combinations. If the number of variables are large the

work load to produce such a response equation would be very high. Furthermore, the ability to accurately predict the computer output will be considerably lower as the number of variables in the response equation increases. The reason for this is that it is difficult to find a response equation which can predict all the computer results without too much deviation. The equation is usually obtained by fitting the computer output to an equation by the method of least squares. A low number of variables are therefore desired, to be able to get a good prediction from the response equation.

5.2 Individual risk method

The life safety is expressed by the reliability index β . This measure represents a value of safety which is comparative between different solutions. The reliability index is calculated for occupants in the room of fire origin and for occupants trying to escape through the corridor. For the guests escaping in the corridor, two indices are presented, one for each corridor length. It is assumed, based on the calculations that the conditions in a neighbouring room not reaches untenable levels. The doors to those rooms are assumed to resist the smoke from spreading to those rooms. The smoke entering the other guest rooms is rather cold but covers the complete space. The levels are in this report not treated as hazardous. The occupants therefore can stay in their room and wait for rescue. This behaviour is, however, not assumed and all guests on the floor where the fire room is located are evacuated. The conditions in the neighbouring rooms are rather uncertain and cases have been reported where people have been killed in fires due to smoke entering the room from outside. At the fire in hotel Caledonien in Norway in 1986, 14 guests died staying in their rooms, even if the doors to the corridor was closed, DBE (1987).

The random variables in the limit state equation can be transformed into the standardised space, where a standardised variable is expressed as

$$X=(X-\mu_X)/\sigma_X \quad (6)$$

and X indicates the random variable. The limit state function is the same in both the real space and in the standardised space. The minimum distance from the origin in the standardised space to the limit state function is equal to the reliability index β , figure 3, according to Hasofer and Lind (1974) which has been shown to be the most suitable measure. Other reliability indices such as the one presented by Cornell (1969) shows some inconsequent behaviour depending on how the limit state equation is formulated, Thoft-Christensen and Baker (1982), and is therefore not used here.

The origin, in the standardised space, is placed in the point of the mean value of the margin, G , expressed in the original space. This is a result from

standardising the variables. The point on the limit state function which has the shortest distance to the origin in the standardised system is called the most probable failure point. This is the point on the limit state function, resulting in the highest probability of failure of the system described by this function. The value of the probability of failure can be approximated by the following relation

$$p_f \cong 1 - \Phi(\beta) \quad (2)$$

The symbol Φ indicates the standardised normal distribution function. If the limit state function is linear and the basic variables are normally distributed there is an equality in the expression. Other transformation functions, than the normal, can be used to achieve an approximation of the probability of failure. However, if the basic variables or functions of these, are summarised, the sum can be approximated to a normal distribution according to the central limit theorem.

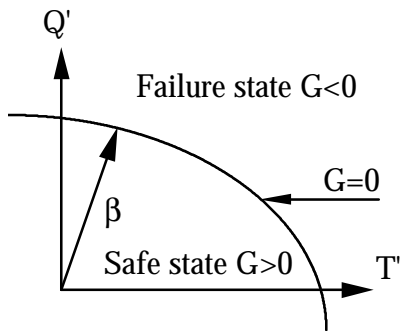

Figure 3. Reliability index β in a two dimensional standardised space with the basic variables Q and T . $G=0$ indicates the limit state function = 0.

The procedure of finding the β -value is to minimise the distance between the limit state function $G = 0$ and the origin in the standardised system. Several such methods are available and described in for example Ang and Tang (1984) and Thoft-Christensen and Baker (1982). This analytical derivation is based on approximations of the limit state function in a first or second order Taylor expansion. These methods are referred to first order or second order reliability methods, FORM or SORM. They can also be referred to as FOSM, first order second moment method or SOSM. It is then implied that the method uses the two first moments of the random variable distributions, mean and standard deviation.

In this work, the reliability calculations have been executed using a computer program, STRUREL (1995). This program calculates both the first and second order reliability index. It is also possible to take the distributions of the variables into consideration and not just the two first moments.

It is not evident that the reliability index β is the most appropriate for describing the risk to humans in a fire situation. As a matter of fact there are methods which are more detailed in addressing the risk to humans in fire. The most obvious disadvantage with the β -method is that it only takes the lack of escape time for the last person reaching the safe area into consideration when trying to describe the probability of failure of the evacuation system. The probability is only addressing the fact that persons are unable to evacuate safely, i.e. the time margin is less than zero. No information is available of the probability that exactly one or two or more are unable to escape. The problem is that the acceptance from the society of having one person unable to escape in 10 fires is higher than having 10 persons being unable to escape from one fire. The consequences is the same for the both cases but the willingness of the society to accept them are not the same.

Still the method is used because it delivers information that is useful and not accessible in other ways such as the design values needed to obtain a specific safety level. Methods providing the information of differentiated human risk dependant on the number of persons unable to escape, PRA-analysis, should be used for deriving F-N-curves, see sections 4.2 and 5.4. Comparison of the two methods, β -method and PRA might be used to derive parameters that could be used for design purposes. As mentioned above the β -method provides the most probable failure point. As this is the desired design-point that should be used in designing an evacuation system, requires that the β -method is used for this purpose, even with its disadvantages. The future design-point can be calculated using an optimisation procedure for a class of scenarios in a similar building group, such as hospitals, Frantzich et al. (1996). The design values will then be valid for a class of buildings and not just one specific. This method can be used to derive a simple design method for the specific class.

5.3 Event tree description

The evacuation safety can be described by using a structured event tree that graphically shows the different scenarios. The event tree organises the events that can occur, for example detection system failing and door to the guest room being open, in a logical way. All the events are associated with a certain probability. By combining these probabilities, the total probability of the scenario can be calculated. That probability is normally calculated by multiplying the branch probabilities leading to the scenario. These probabilities associated to the final scenarios can be used to derive the risk to the society as described in section 4.2 and further elaborated in section 5.4. Some values of the necessary branch probabilities are presented in this report for completeness. As one of the purposes with the report is to derive the reliability for each scenario on the condition that the scenario has occurred, the information about the fire frequency will not be used in those calculations. The presentation technique will be described in

section 5.5. The fire frequency will be used when presenting the risk to the society.

5.3.1 Event sequences

The calculation of risk is performed on the final scenarios indicated in the event tree, figure 4, each having its specific limit state function. The initial event is a fire that has started in a guest room. The first condition is whether the guest wakes up directly by the fire before any alarm will start. If the guest is awake or wakes up at this stage, he or she can rather safely walk out from the room and alert the management by using the alarm button in the corridor. This probability is set to 0.1. This means that in 1 case of 10, the guest is awake when the fire starts or wakes up by the fire.

If the guest does not wake up, the next step in the event tree is to determine if a fire detection alarm is able to detect the fire. If a fire detection alarm is present and working it is supposed to alert the management of the hotel. The alarm does not activate the escape alarm signals in the hotel, only the staff is alerted. This is the normal procedure for hotels in Sweden as the management does not want all the guests to be alerted directly if the detection system is indicating a false alarm. When the fire is detected and the staff is notified, the reason is investigated by the staff. If there is a fire in the hotel, the staff can push the alarm button, located on several positions on the floor, and the escape alarm starts. In some cases the local fire brigade is also alerted at this time. The escape alarm can either be heard in the whole hotel or only in some parts for example on the floor on fire. In the latter case, phased evacuation of the hotel can be performed. In phased evacuation, the people are evacuated in special order depending on the hazard. Usually the floor on fire and the one above and the one beneath are evacuated first.

For some of the scenarios it is assumed that an alarm signal is located in the guest room on fire to alert that guest directly after detection. The guest can then evacuate before the staff has investigated the fire alarm. The safety of the guest is improved by adding the alarm signal in the room but the other guests will not be affected by this. It is assumed that the signal cannot be heard through the walls. Therefore the scenarios 9 and 11 for the corridor will be the same as scenarios 5 and 7.

If the guests have to be waken by the alarm signal, their responses are probably affected by the type of signal. Two types of signals are studied with respect to the life safety. The alarm can be a traditional alarm bell located in the corridor or an alarm signal located in the room. The latter signal is assumed to give two types on signals, flashing light and a tone signal. This results in different response times for the guests.

The last option in the event tree is the choice of having the door to the guest room being open or closed. When calculating the risk in the fire room, the door is always assumed closed. This is the normal condition. To create hazardous conditions in the corridor it requires that the door between the fire room and the corridor is kept open. The door can be kept open if something is blocking the door or if the closing device is out of order. In most hotels, the door swings into the guest room and the pressure in the room will then force the door to close. The door closing device can also assist in keeping the door closed. There might, however be cases when the door is open and these scenarios have to be considered. These are the reasons for only looking at the risk in the fire room when the door is closed and the risk in the corridor when it is open.

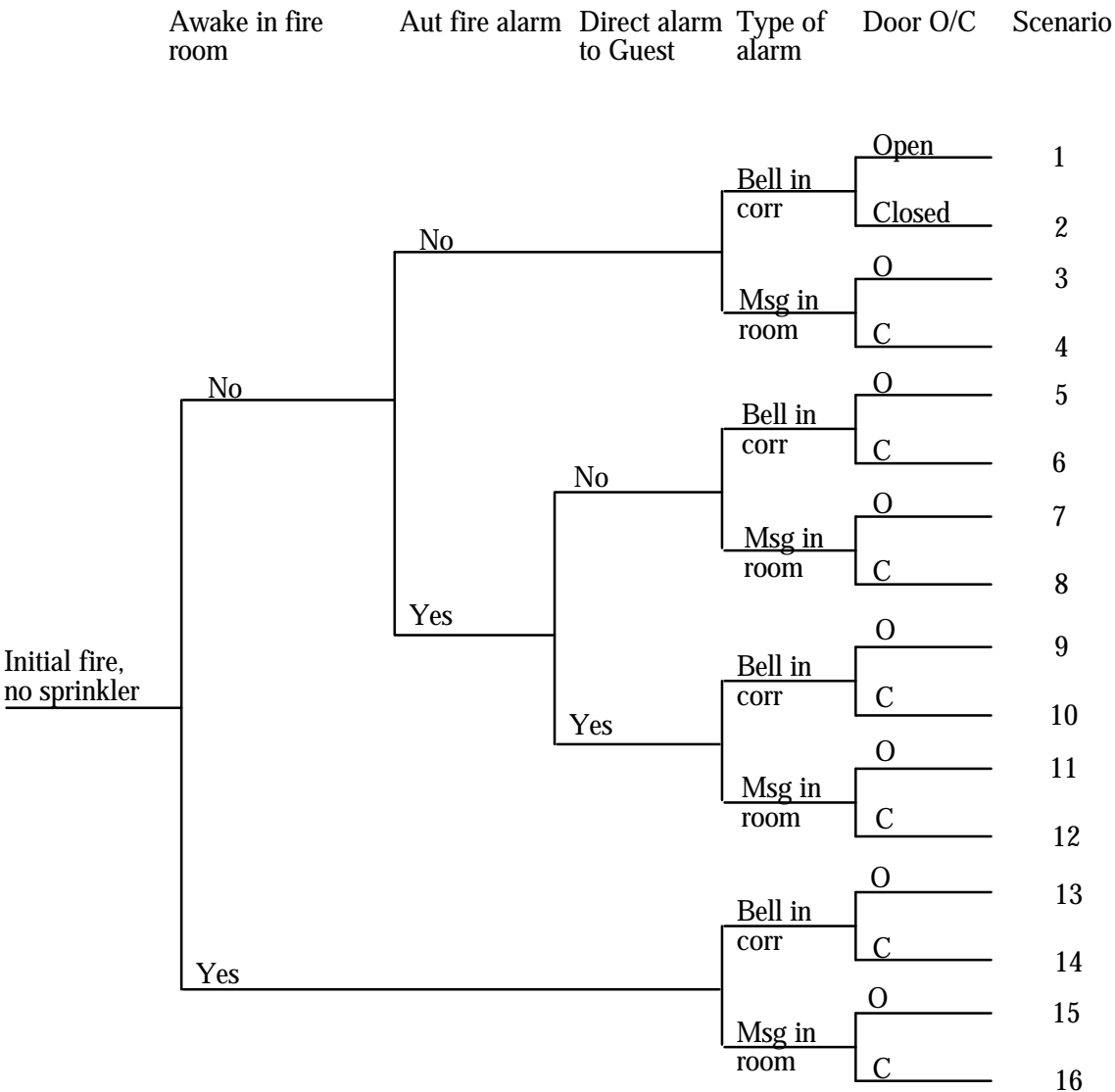

Figure 4. General event tree describing the basic scenarios.

5.4 Societal risk method

The evacuation safety for the hotel is also evaluated using a traditional Probabilistic Risk Analysis, PRA. The method by which the safety is evaluated differs from the previous individual risk method. A standard PRA determines each outcome by using variable values, in the limit state function, which are likely to occur. Usually the mean value for each variable is used. With these values, the consequences for each scenario can be calculated. A PRA analysis is usually linked to the used of an event tree. Each scenario is subjected to a probability. By sorting the consequences in ascending order they can be shown in a diagram as an F-N-curve.

But if only the mean value of the variables are used to calculate the number of people not being able to evacuate within the time limit, no information is presented regarding the uncertainty. Therefore, the consequences can be recalculated a number of times and changing the values of the variables so the uncertainty of the variables are taken into account. This is done by using Monte Carlo simulation of the equations in the event tree. Every iteration in the simulation produces a separate F-N-curve. By looking at all the curves, the uncertainty in F-N-curve results can be estimated. In the figures showing the resulting F-N-curves both the mean curve and the 80 %-tile curve are displayed. As the number of Monte Carlo iterations is large, not all the results can be shown.

As the description of the problem by the event tree is the same as for the individual risk calculations, the same conditions are still relevant. That is for example the assumption that the conditions in a neighbouring room not reaches untenable levels. All the guests are evacuating the floor after being notified of the threat and no-one stays in their room.

The event tree is not a pure event tree as one gate is no probability gate. The choice of escape alarm is not subjected to a probability but is a condition for the scenarios studied, described by the tree in figure 4. This means that if the investigated scenarios contain an escape alarm with an alarm bell, the probability in this gate for this choice is unity. This type of structured tree is normally called a decision tree. But as only one gate is a decision gate, the term event tree will still be used.

A more detailed description of the method used can be found in for example CPQRA (1989), Helton (1994) and Magnusson et al. (1995).

5.5 Individual risk presentation technique

There are many different methods available for presenting the quantitative results from a risk analysis. Depending on what sort of information that is going to be presented, different methods are used. Individual risk to humans from a chemical plant can be presented as risk contours plotted on a map. At different distances from the plant the individual risk will be different, decreasing with the distance. Also, the risk can be different in two directions because of variability in wind direction.

The risk to the society is usually presented as so called F-N-curves showing the frequencies for different number of expected fatalities. A high number of expected fatalities is normally linked to a low probability of occurrence. It is up to the authorities having jurisdiction to determine in what way the risk should be presented and what the acceptance criteria should be.

As many of the presentation methods are developed for process industries, transportation of hazardous goods or nuclear power plants, neither of them are very good for the risk measures used in this report. The individual risk can, however, be presented rather easy for each scenario. There are only three locations present in this analysis, the fire room and the two corridors. Different assumptions regarding the basic variables will also affect the level of the resulting reliability index β . The presentation will therefore be made so that the β -values for the different scenarios and with various parameters for the basic variables are easily comparable. In the diagrams for the individual risk, only the reliability of the limit state function will be presented. This means that the only uncertainties affecting the result are those included in the basic variables forming the limit state function. The probabilities for the scenarios, i.e. the probabilities at the branch points in the event tree are omitted in the calculated β -values.

To be able to also include information about the likelihood for the different scenarios, another presentation method will also be used. This method has large similarities with the F-N-curve technique. The β -values, representing the consequences of the scenarios, will be plotted in relation to the likelihood of the corresponding scenarios. This means that a specific design will be studied each time, i.e. one design of the safety strategy for a hotel each time. This is a consequence of the fact that a hotel has not for example both types of escape alarms installed. Not all scenario outcomes will therefore be of interest and not be examined.

Each safety design will result in a curve, connected by its β -value and outcome probability pairs, which can be used to compare different design solutions. It must at this point be noted that the x-axis indicating the values of β is highly unlinear in terms of the consequence level. The probability of having an

unsuccessful evacuation is not 50 % less if the value of β is increased from 1 to 1.5. The two corresponding probabilities according to equation 2 are 15.8 % and 6.7 %. A safe design should be located in the lower left corner of the diagram.

The pairs of β and scenario probability are sorted by decreasing β -value, i.e. by increasing hazard. The outcome probabilities used in the diagram are the complementary cumulative probabilities. The highest β -value has a probability of occurrence of $1-p_{\beta 1}$. The following probabilities are then achieved by reduction of the former by the actual outcome probability. A kind of complementary cumulative distribution function, CCDF, is achieved which can illustrate the risk in a manner which is similar to the one presented in IAEA (1989). The CCDF shows the probability of having consequences worse than the related value on the x-axis. Compare with the traditional cumulative distribution function, CDF, which shows the probability of having a better situation than the x-axis value.

Example

To illustrate the presentation method an example is provided. Figure 5 shows an example of the curve described above. The events used in this sample are originating from the events illustrated by the partly shown event tree in figure 6. The results from the risk calculations used in figure 5 are summarised in table 1. Each scenario outcome, in a design solution, is associated to a likelihood of occurrence. This probability is achieved by multiplying the branch probabilities leading to the outcome. The vertical distance between the horizontal lines are determined by these probabilities.

The example hotel has an automatic fire alarm system with a reliability of 80 %. The guests are made aware of the need to evacuate by alarm bells located in the corridor. There is no direct alarm to the guest in the room of fire origin. The presented example is showing the conditions for the 30 m corridor and then it is assumed that the door between the fire room and the corridor is open. This results in three scenarios that are of interest, scenarios 1, 5 and 13. The consequences, i.e. the β -values, are obtained from the individual risk analysis presented in figure 7 in section 7.1.

The initial probability has also to be considered when deriving the branch probabilities. However, as including this probability only moves the curve to either side it has been omitted for clarity in the example and in the diagrams presenting the results later in the report. The probabilities in the example, then assumes that the event has started, i.e. the fire has been initiated and the door between the fire room and the corridor is being open.

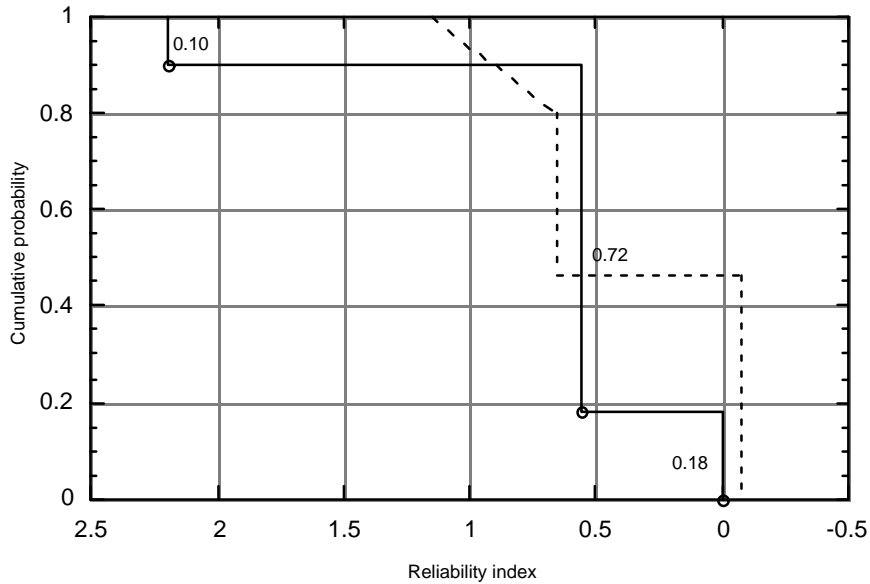

Figure 5. Example of total reliability for a design solution.

In figure 5, a dashed acceptability line is also drawn more to illustrate that it is possible to make a definition of what is acceptable and what is not. The line is drawn purely by random and has no connection to any real acceptability decided by any authority. In the example, the design does not comply with the acceptable standard as the design line exceeds the dashed line at one place. The solution is to increase the reliability for one of the outcomes or to change the branch probabilities. In this case, changing the probabilities, could be difficult as the only probability to change, that will affect the safety is the awake/asleep condition.

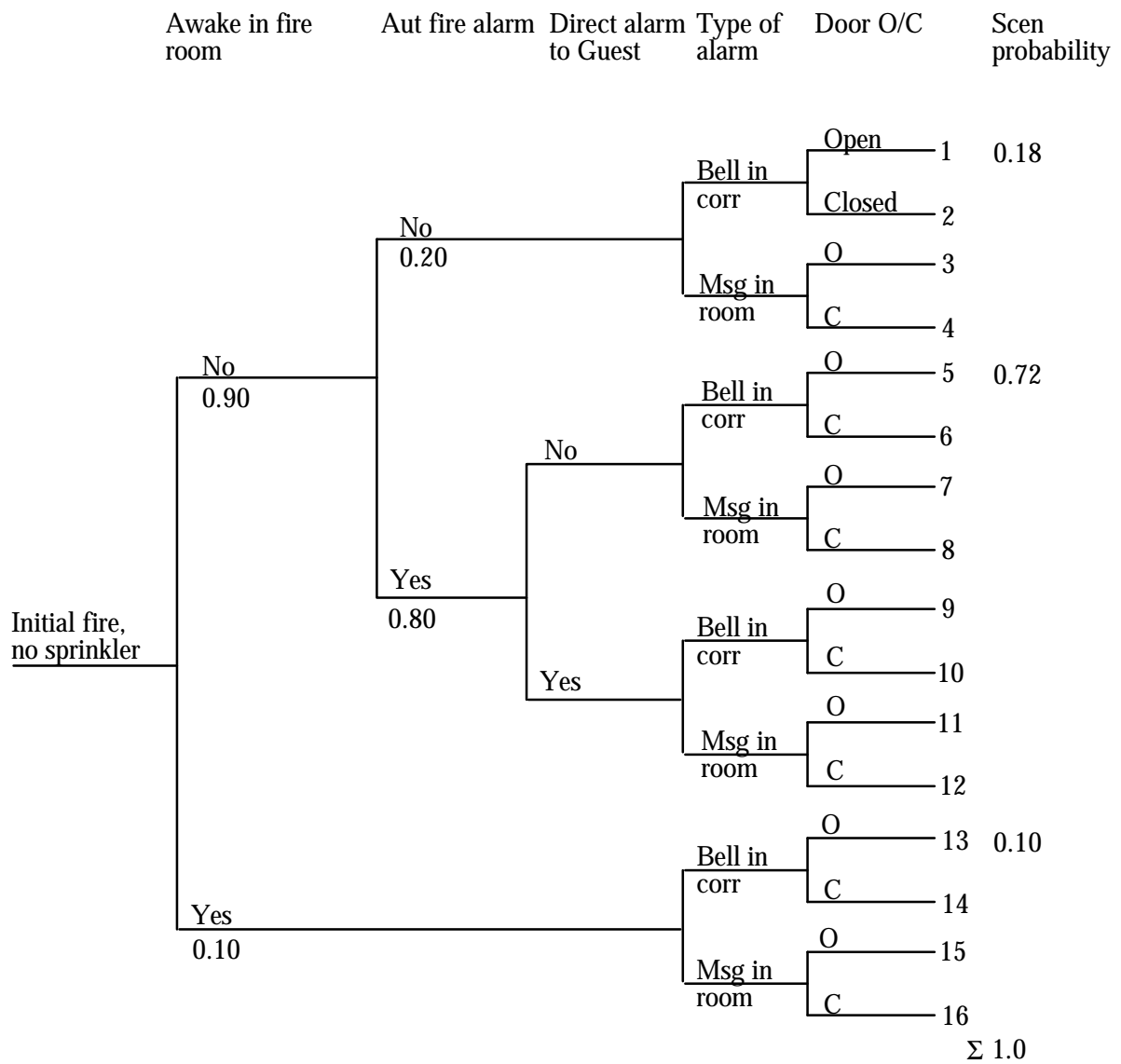

Figure 6. Event tree used to create the sample diagram in figure 5.

Table 1. Data used in figure 5.

Scenario	β -value	Scen. probability	Cumulative prob.
13	2.20	0.10	0.90
5	0.56	0.72	0.18
1	0.00	0.18	0.00

6 Fire safety calculations

6.1 Untenable conditions

The evacuation from the guest room and from the corridor must be finished before untenable conditions in those parts arise. The time to reach untenable conditions is determined by maximum levels of radiation, elevated temperature and toxic gases that people on the location can be subjected to. The tenable conditions are chosen so they will be valid for an average person, but the chosen values are rather conservative and on the safe side. Work by Purser (1988) are used in deriving what is untenable conditions. The limits used for determining untenable conditions are shown in table 2. Two different sets have been used for a sensitivity analysis. This set with extended levels is marked with High level in table 2.

Table 2. Untenable conditions.

Condition	Normal	High level
Radiation	2.5 kW/m ²	2.5 kW/m ²
Smoke layer height	1.5 m if T _g > 80 ° C	1.5 m if T _g > 100 ° C
Temperature in layer	80 ° C if z < 1.5 m	100 ° C if z < 1.5 m
Toxicity	FED = 0.5	FED = 0.5

The condition first reached determine the time to untenable condition. Toxicity is measured in terms of the Fractional Effective Dose, FED, which is a measure that takes the effect of some toxic gases into account, Purser (1988).

These levels which are used in the calculations are pure deterministic values without any uncertainty. This is not true in the reality. The sensitivity level for various exposures to people are varying. Young people are probably not so sensitive to heat and toxic gases as elderly. When a more detailed risk analysis is going to be performed also the untenable levels should be subjected to uncertainty. Using the above numbers will, however, produce results on the safe side. When comparing the calculated risk to traditional levels of acceptable risk one must see to compare the same things. Usually, levels of acceptable risk assumes number of deaths as the consequences. When using the untenable conditions above, it is unlikely that even one person will decease from this exposure. Therefore, the comparison shall be performed knowing this difference.

6.2 Fire specifications

The energy release rate from the fire is assumed to follow an αt^2 relationship. The location of the fire could either be in one of the guest-rooms or in an adjacent part of the building. In the latter case it is assumed that smoke will enter the corridor through elevator shafts, staircases or similar vertical openings. The calculations for this case are the same as if the fire is located in the guest room. The two escape routes will, however always be possible to use.

Each risk calculation location, fire room and corridor, will be provided with an equation describing the time to untenable conditions. As the time to reach untenable conditions will be depending on the growth rate factor of the fire α , the value of α has to be determined. From experiments and observations from real fires in hotel rooms, a fully developed fire is likely to occur in the guest-room of fire origin. However, it is also necessary to consider those fires which do not develop into a fully developed fire. A distribution of the fire growth factor, α must therefore cover both the fast fire and the slower developing one. The fire growth factor will follow a lognormal distribution with mean 0.02 kW/s² and a standard deviation of 0.01 kW/s². Two other characteristics were investigated for some scenarios. These fires have α -values following a lognormal distribution with a mean value of 0.01 kW/s² and a standard deviation of 0.01 kW/s² and 0.02 kW/s² as the mean value and 0.005 kW/s² as the standard deviation for the second extra fire.

6.3 Time to untenable conditions

The time to reach untenable conditions is derived using the computer model CFAST, Peacock et al. (1994). CFAST calculates temperature, smoke layer height, radiation etc. in every room for the scenario. The user has to define the scenario with room structure and layout. The calculation uses a user defined fire specification to calculate the conditions. One simulation with CFAST takes around 1 minute to perform and it is therefore not suitable for direct use in the statistical work.

CFAST has been used to derive a regression equation, or response equation, describing the time to reach untenable conditions as a function of the growth rate of the fire, α . The fire is supposed to start on a piece of furniture or in a waste paper basket with a height of 0.5 m from floor level. For each scenario and opening condition of the door to a guest-room, six calculations with different values of α were performed. The time to reach untenable conditions was determined in each case. With values of α and untenable time, a regression equation was created. This equation is used in the statistical treatment as a substitute for the actual CFAST results.

The conditions in a neighbouring guest-room will be calculated with the assumption that the door to that room is closed. The only opening between the corridor and the room will be through leaks between the door and the door frame. The door between the guest-room on fire can either be open or closed depending on the scenario. It is also assumed that the fire will be limited to the room of origin and no fire spread will take place to the corridor. This will be true for the first minutes of the fire and within the evacuation time.

From observations of real fire situations in hotels it can sometimes be assumed that the door between the fire subjected guest-room and the corridor can be open.

In the fire in Hotel Leningrad in 1991, Brandsjö (1991), the staff of the hotel went to investigate the possible fire in a guest-room. After discovering the fire they were unable to close the door afterwards. The door was kept open during the whole fire enabling the fire to spread to other parts of the building. However, doors in hotels in Sweden must be equipped with door closing devices and are usually opening into the guest-room. The possibility that the door to the room on fire is open will be limited. The fire will tend to close the door due to the pressure build-up in the room. An open door must therefore be kept open by something obstructing it from closing or the closing device must be malfunctioning. For the calculation of societal risk, the probability that the door will be kept open must be defined. For these calculations this probability is set to 0.05.

6.3.1 Room of fire origin

Using the regression analysis technique to derive an analytical expression for the time to untenable conditions results in

$$S=11.5 \alpha^{-0.44} \text{ (normal tenability)} \quad (7)$$

The equations are derived using the normal tenable conditions in table 2. The equation assumes that the door between the fire room and the corridor is closed. This is the condition for the guest-room as long as the door is not held up deliberately. This is, however, not likely. The time to untenable conditions is not affected by different breaking conditions of the window in the guest room. Time to untenable conditions always occurs first. The choice of breaking condition will on the other hand be important to the conditions in the corridor. If, however, the high level tenable conditions are used the equation for time to untenable conditions will be;

$$S=10.6 \alpha^{-0.48} \text{ (high level tenability)} \quad (8)$$

6.3.2 Corridor

The time to untenable conditions in the corridor depends on the fire conditions in the fire room. The fire will in no case start in the corridor. If the door to the fire room is closed, no untenable conditions will occur in the corridor. If the door to the fire room is open, the time to untenable conditions will be depending on the choice of breaking condition for the window in the fire room. After performing a sensitivity analysis, Frantzich (1996), of the response to different breaking conditions of the window, it is assumed that 60 % of the glass will fall out when the temperature in the upper gas layer reaches 250° C. Different breaking conditions were investigated and the chosen one represent an average of the different results. The deviation in time to untenable conditions in the corridor is not very sensitive to the choice of breaking condition.

The time to reach untenable conditions in the corridor is according to the following equations. The door to the guest room on fire is open after the first minute.

$$S=50.5 \alpha^{-0.41} \text{ (60 m corridor, normal tenability)} \quad (9)$$

$$S=54.5 \alpha^{-0.44} \text{ (60 m corridor, high level tenability)} \quad (10)$$

$$S=53.2 \alpha^{-0.35} \text{ (30 m corridor, normal tenability)} \quad (11)$$

$$S=55.9 \alpha^{-0.38} \text{ (30 m corridor, high level tenability)} \quad (12)$$

6.3.3 The other rooms

The situation in a neighbouring room is also investigated. The door to the room is closed during the simulation and only small leakage openings exist. The condition never reaches untenable levels in this room. Smoke will enter the neighbouring rooms. The smoke level, will according to the calculations, descends to approximately 1 m above floor level but the temperature will not rise significantly. It is, however, not believed that the calculations predict the conditions very accurately. Most probable, the smoke entering the neighbouring room will fill the room completely but with rather light smoke. If the window to the outside in that room is opened the conditions will be considerably improved. In the calculation it is completely closed. The risk to the occupants can probably be ignored, at least for the first 15 minutes of the fire. As each guest room is a separate fire compartment the smoke shall according to the code, not be able to enter for at least 30 minutes.

6.4 Model uncertainty

The ideal model would predict the reality without any deviation. However, limitations and simplifications are some factors which results in a deviation between the model result and the reality. Two computer models have been used in this study. CFAST is used for the prediction of the time available for evacuation or the time to untenable conditions. The other model is Detact-t2, Evans and Stroup (1985), for the prediction of activation times for detectors and sprinkler heads. There is a difference in result between the computer model and experiments. Therefore a model uncertainty factor has been introduced. In a study by Bragason 1994 comparing CFAST results with experiments, the factor for time to untenable conditions, can be derived as a normal distribution with the following parameters (1.35,0.11). In this variable the error of the regression equation is included. This error originates from deviations between the calculated CFAST results and the regression equation. Actually this error is much lower than the error between the calculations by CFAST and the experiments. The standard deviation between the experiments and CFAST calculations is also 0.11.

The model uncertainty for Detact-t2 is unknown. Activation time in a real room is very much depending on the configuration in the ceiling and other obstructions in the upper part of the room. The calculated detection times are then assumed to follow the theoretical relations in Detact-t2 without any correction, which probably is on the unsafe side.

6.5 Active systems

Sprinkler is not mandatory in hotels in Sweden. If a fire occurs in the lobby of a hotel a sprinkler system will have the opportunity to extinguish that fire and make the situation better in for example the upper floors. Installing a sprinkler system in the guest-rooms will have no effect of the safety level in the room of fire origin. The neighbouring rooms and the corridor will though be tenable for a longer period of time if the door to the room of fire origin is open during the fire.

The sprinkler system will be compliant to the Swedish sprinkler guidance RUS 120:4. This results in two sprinkler heads per guest-room. The response time index, RTI-value, will be $35 \sqrt{m \cdot s}$ and the activation temperature is 68 ° C. The sprinkler heads will be placed in an optimum way to cover the whole guest-room. The influences from both an automatic fire alarm and two types of escape alarms will be studied in this report.

The presence of an automatic fire alarm system will be subjected to the scenario in the event tree. Automatic fire alarms with smoke detectors are mandatory for hotels in Sweden if they are higher than two floors. It is also necessary to have the alarm installed if the hotel is on other floors than on the ground floor. For the calculations it is assumed that the alarm system is equipped with smoke detectors in all guest-rooms and in adjacent corridors. One detector is installed in each guest-room. If a fire occurs, the automatic fire alarm alerts the managing staff. The staff shall then take necessary actions. Usually, the staff will investigate the reason for the alarm and if needed, activate the escape alarm. If no staff is present the fire brigade should be alerted automatically when the fire is detected. When calculating the societal risk the availability of the system must be determined. For these calculations this probability is set to 0.95. This means that in 95 % of the cases when the alarm system is needed, it will also work.

Escape alarm is mandatory for hotels in Sweden. In all hotels, alarm buttons shall be present on every floor notifying the staff of for example a fire. In some cases, the escape alarm starts directly when any of the alarm buttons is pushed at least on the floor where the button is located. This is also assumed in all the calculations. If no staff is present in the hotel, the escape alarm shall start in less than 30 seconds if the fire is detected by an automatic fire alarm. The probability that the escape alarm will work when it is needed is included in the data for the automatic fire alarm. For those cases where a direct alarm is sounded in the fire room the availability for that device is set to 0.98.

Two types of escape alarm signals are studied in the calculations. Different alarm signals will result in different interpretations of the event. This will further lead to variations in response time for the guests in the hotel. Alarm signals which contains more information than for example an alarm bell will result in shorter response and behaviour times which will lead to a higher safety level, Bellamy et al. (1990). A good escape alarm signal could be a verbal informative message or light and sound in the room. If flashing light and sound is used, a notice must be present informing guests of the meaning of the signals and what they are supposed to do when they hear and see the alarm signal. This type of escape alarm is one of the used in the calculations. The other one is a standard alarm bell located in the corridor. The response time for the different escape alarms are presented in section 6.8.

6.6 Detection time

The detection time will be depending on how the fire is detected. The fire can be detected by an automatic fire alarm system or manually by the guest in the room or by someone outside the room. In the case when the fire is discovered by a smoke detector in the fire room the time to detection can be calculated using the following expression

$$D=20.6 \alpha^{-0.30} \tag{13}$$

This detection time is used for the cases where the person in the room is not woken up by the fire. If the person is awake when the fire occurs and not extinguishes the fire, the detection time is assumed to follow a lognormal distribution with the following parameters, $\Lambda(15, 3)$ seconds. This detection time is denoted t_{Det2} in appendix A.

If the fire is not detected by the person in the room or by any smoke detector, someone outside the room has to see the fire. For these cases the detection time is assumed to follow a uniform distribution ranging from 120 seconds to 300 seconds. This detection time is denoted t_{Det1} in appendix A. The guest in the room of fire is assumed to be notified directly after the fire has been manually detected. Usually, the available time has then expired.

6.7 Investigation time

When the fire is detected by the fire alarm the staff will be notified. They will then investigate the reason why the alarm went on. If there is a fire and no false alarm, the staff can initiate the escape alarm. The same actions will be taken if the fire is detected by somebody outside the room of fire origin. For these cases it is assumed that the investigation time, t_{Inv} , will follow a lognormal distribution, $\Lambda(60, 15)$ seconds. The staff will otherwise have no active participation in the evacuation.

6.8 Guests

After the guest has been aware of the fire situation he or she has to take some actions. The action sequence can be very different, depending on the specific individual. Frequent actions by guests in hotels are getting dressed, alerting roommates, looking out through the window etc. In the end the person will try to escape from the room to a place of safety. All the actions performed takes some time to do. These actions are valid for the persons not staying in the room of fire origin. In that room the first objective is probably to get out from the room or extinguish the fire. The response and behaviour time shall include the time spent doing all the actions before the action to escape is initiated. The behaviour time can also include actions performed during the evacuation.

In the room of fire the response time is assumed to follow a lognormal distribution with the following parameters, $\Lambda(15, 3)$ seconds. This time is denoted RFire in appendix A. For people in other rooms, the response time will be depending on the type of escape alarm. The assumed times will be valid for night conditions, i.e. all the persons in the hotel are asleep. After hearing the alarm signal the guests have to wake up and understand that they must evacuate from the room to a safe place. If the escape alarm is a flashing light and a tone signal located in the guest room the time will follow a lognormal distribution, $\Lambda(60, 30)$ seconds. This time is denoted Rneighb2 in appendix A. If only an alarm bell, located in the corridor is used, the response time will be log-normally distributed, $\Lambda(120, 20)$ seconds. This time is denoted Rneighb1 in appendix A.

It is assumed that the guests are representing the average population of persons visiting hotels. This includes some persons that may suffer from physical disabilities, i.e. wheelchair users and similar. All guests are capable of understanding the fire threat even if it can take long time. No mentally disabled persons are present.

6.9 Movement time

The movement time is the time spent by guests moving from their rooms to the point of safety. The guests are safe when they have reached the staircases in the ends of the corridor. The guest in the room on fire is, however assumed to be in safety, just outside the room. It is assumed that no queuing problems will arise when people are entering the staircases. This assumption is valid if the number of people escaping is fairly small as in the present case.

The smoke transport model CFAST does not distinguish between the different locations of the fire within the compartment. The resulting smoke layer height and temperature will be independent of the position of the fire room in the corridor. A fire in a room in the end of the corridor will result in the same conditions as a fire in a room located in the middle of the corridor. To take this variation into account different travel times in the corridor can be used. If the

fire starts in a room near one of the staircases that staircase is assumed to be blocked and not possible to use. The guests then have to use the other staircase. In the long corridor the guest closest to the fire has to move for 60 m. If on the other hand the fire is located in the middle of the corridor both staircases can be used and the guest closest to the fire has to move for 30 m. If it is assumed that the probability of a fire is the same for every room the average distance for the worst situated guest will be 45 m as an average.

The physical differences in the hotel population will be taken into account in assessing the movement time. Elderly people with some physical disabilities can walk with a velocity of 0.78 m/s, Shields et al. (1995). Even slower individuals can of course be present. Wheelchair users often travel with a higher velocity. A maximum velocity can be taken as 1.6 m/s for healthy individuals. A mean value of 1.2 m/s can be assumed using the two above velocities. The movement time for an individual in the longer corridor, $t_{MCorr60}$, can therefore be assumed to follow a normal distribution with a mean of 37 seconds and a standard deviation of 6 seconds. This will cover differences in travel speed and location of the fire. For the 30 m corridor, $t_{MCorr30}$ has the following parameters, normal distribution (20,3) seconds.

The movement time in the fire room, t_{MRoom} , is assumed to vary uniformly between 3 and 8 seconds. For the case where the guest in the fire room is awake and can run out from his room to push the alarm button the time spent in moving from the room to the button, t_{Button} , is uniformly distributed (5, 15) seconds.

7 Result

The complete limit state function for the risk calculations is

$$G = S \cdot U_s - D - t_{Inv} - R_{Fire} - R_{Neighb} - E - t_{Button} \quad (14)$$

$S =$	time to untenable conditions
$U_s =$	model uncertainty for CFAST
$D =$	detection time (calculated or t_{Det})
$t_{Inv} =$	investigation time for staff
$R_{Fire} =$	response time for guest in fire room
$R_{Neighb} =$	response time for guest in neighbouring room
$E =$	movement time (t_{MRoom} , $t_{MCorr60}$, $t_{MCorr30}$)
$t_{Button} =$	time for guest to move to an alarm button

All the variables are not used at the same time, i.e. they are for some scenarios assigned the value 0. The variables S and calculated detection time are both functions of the fire growth rate α . In tables 3 and 4, a summary of the random variables are presented with information of the scenarios they are used in. In appendix A is a complete list of all the random variable and the equations used displayed. The reliability index is calculated for two locations in the hotel, in the fire room and in the corridor. The corridor is chosen because the guests in the neighbouring rooms have to pass the corridor in their way to the safe location. For the societal risk, both the fire room and the corridor is treated at the same time as they are both part of the event tree. The whole tree is examined at the same time.

Table 3. Basic variables used in the different room scenarios.

Variable	Room scenario							
	2	4	6	8	10	12	14	16
α	x	x	x	x	x	x	x	x
U_s	x	x	x	x	x	x	x	x
t_{Det}	x	x					x	x
t_{Inv}			x	x				
R_{Fire}	x	x	x	x	x	x	x	x
R_{Neighb}								
t_{MRoom}	x	x	x	x	x	x	x	x
t_{Button}								
$t_{MCorr30}$								
$t_{MCorr60}$								

Table 4. Basic variables used in the different corridor scenarios.

Variable	Corridor scenario							
	1	3	5	7	9	11	13	15
α	x	x	x	x	x	x	x	x
U_s	x	x	x	x	x	x	x	x
t_{Det}	x	x					x	x
t_{Inv}	x	x	x	x	x	x		
R_{Fire}							x	x
R_{Neighb}	x	x	x	x	x	x	x	x
t_{MRoom}							x	x
t_{Button}							x	x
$t_{MCorr30}$	x	x	x	x	x	x	x	x
$t_{MCorr60}$	x	x	x	x	x	x	x	x

The reason for using so many variables in scenarios 13 and 15 for the corridor is that the guest in the fire room wakes up by the time the fire starts and starts the activation of the escape alarm. After hearing the alarm, the guests in the neighbouring rooms then have to respond and take necessary action. This means that the actions by both the guest in the fire room and the others are considered in these calculations.

When calculating the individual risk of escape from the fire room it is always assumed that the door to the corridor is initially closed. Therefore, no fire room scenarios have been calculated where the door is open, according to the event tree description. In the same way, the calculated scenarios for the corridor are those where the door is kept open after the guest in the fire room has left. If the door is closed no untenable conditions will occur in the corridor. The door between the guest room and the corridor shall according to the Swedish building regulation be equipped with a closing device. The function of this closing device is then of vital importance to the safety during evacuation through the corridor. If it works, no untenable conditions will arise on that location from a fire in a guest room. For the societal risk, the probability that the door closing device is not working properly is considered in the risk measure, the F-N-curve.

A fire originating in another location can cause untenable conditions in the corridor if smoke can spread through stairways, openings in the floor structure or through the outside of the building. It is, however, assumed that this scenario can be prevented by passive protection systems in the hotel.

7.1 Reliability index

The resulting values of the reliability index β for the scenarios, using the standard values on the basic variables, are presented in figure 7. The figure shows the reliability using the limit state function with its basic variables and no consideration has been taken to likelihood of the events. As can be seen from the figure some results have ended up on the negative side. This result is not possible to interpret strictly geometrically when looking at figure 3. The results,

however, have mathematical realisations as they are leading to a probability of failure exceeding 50 %. When a scenario exceeds this level it is assumed that it is so much on the unsafe side that it is further not considered. The only results of importance are those leading to positive β -values. Note the relationship between the β -value and the probability of failure in equation 2.

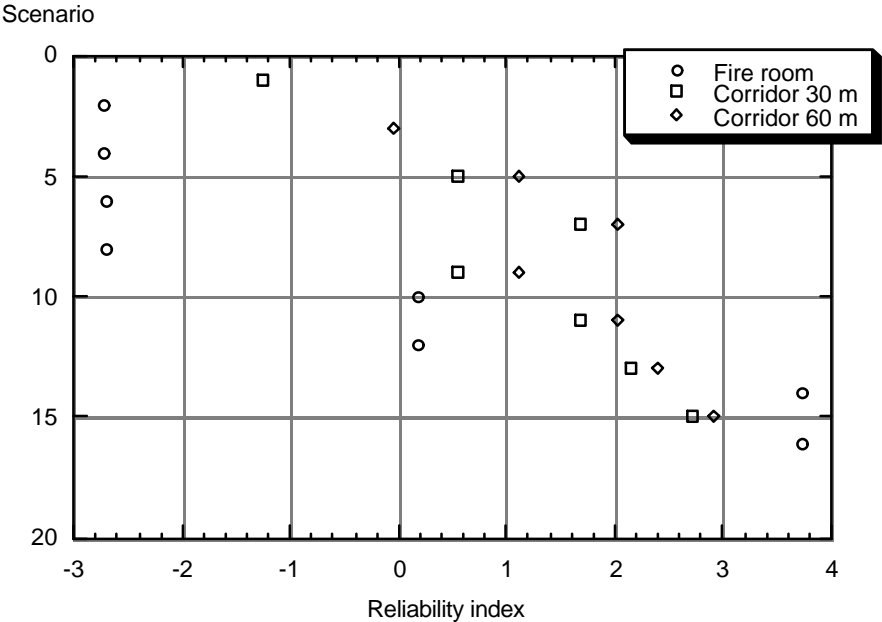

Figure 7. Reliability index β for room and corridor scenarios.

One result that might seem unrealistic is that the longer corridor results in higher β -values. One might expect that the more people using the corridor, the more unsafe would the conditions be. This expectation would result in a lower β -value. But as the corridor volume is much larger for the longer corridor, the time to reach untenable conditions are still much longer than for the shorter corridor. This result is also depending on the fact that the number of persons are not affecting the calculation of the reliability. It is assumed that there will be no queuing at the doorways. The movement time will only depend on the walking time to reach the door. The number of persons are not considered in deriving this time.

The reliability index will also depend on the choice of tenability limits. The calculation of time to untenable conditions was performed for both tenability criteria in table 2 in section 6.1. The available evacuation time will be longer if the High level conditions are used. If the other variables are kept unchanged, an increase in reliability index is expected. The new β -values for this circumstance are presented in figure 8. These can be compared to the equivalent β -values in figure 7 showing the results using the Normal tenability limits.

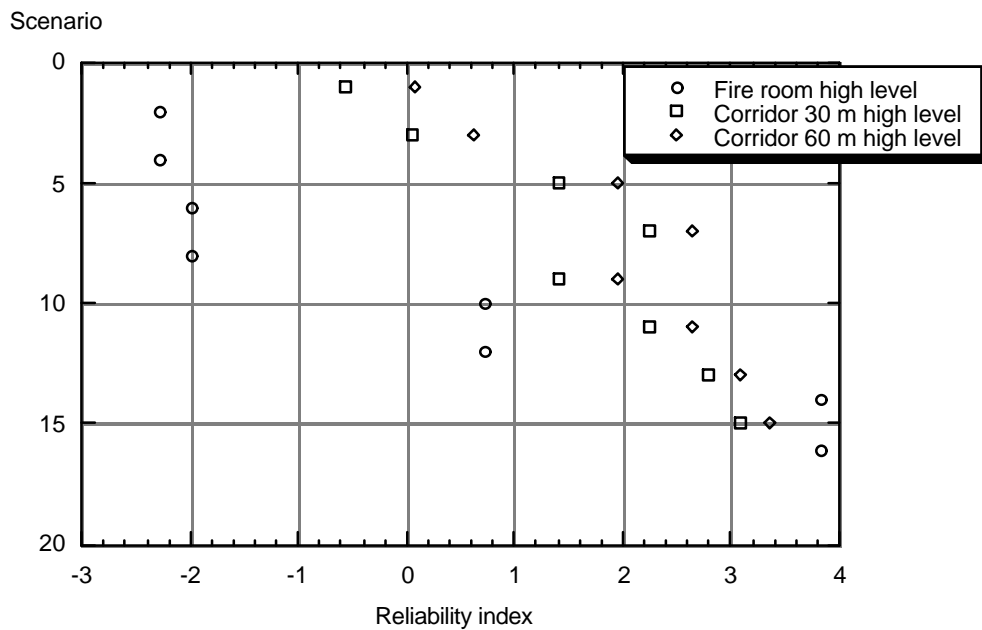

Figure 8. Reliability index β for room and corridor scenarios using higher tenability limits.

In the following some examples of the escape reliability will be presented which also considers the branch probabilities. The technique used for these diagrams is presented in section 5.5. As many of the estimations of the different branch probabilities are chosen with little statistical information as a base, the results must only be seen as examples. They can still be used to compare different design solutions to each other, but the real safety level might be wrong. The cases are differing in design solution, installations and assigned probabilities. For the scenarios where the reliability index is less than 0, the value 0 will be used instead.

Case 1

Hotel with 30 m corridors and rooms on both sides.

Probability of person in guest room not wakes up is 90 %.

Automatic fire detection system with smoke detectors is installed with a operational probability of 95 % (including the alarm bell reliability).

Escape alarm with alarm bells in the corridor, and no alarm in fire room.

Scenarios which are applicable in the event tree; 1, 5 and 13.

Result in figure 9.

Scenario	β -value	Scen. probability	Cumulative prob.
13	2.16	0.10	0.90

5	0.56	0.72	0.18
1	0	0.18	0.00

Case 2

Hotel with 30 m corridors and rooms on both sides.

Probability of person in guest room not wakes up is 90 %.

Automatic fire detection system with smoke detectors is installed with a operational probability of 95 % (including the alarm bell reliability).

Escape alarm with light and sound alarm in every.

Scenarios which are applicable in the event tree; 3, 7 and 15.

Result in figure 9.

Scenario	β -value	Scen. probability	Cumulative prob.
15	2.71	0.10	0.90
7	1.68	0.86	0.04
3	0	0.04	0.00

Case 3

Hotel with 30 m corridors and rooms on both sides.

Probability of person in guest room not wakes up is 90 %.

Automatic fire detection system with smoke detectors is installed with a operational probability of 90 % (including the alarm bell reliability).

Escape alarm with light and sound alarm in every.

Scenarios which are applicable in the event tree; 3, 7 and 15.

Result in figure 9.

Scenario	β -value	Scen. probability	Cumulative prob.
15	2.71	0.10	0.90
7	1.68	0.81	0.09
3	0	0.09	0.00

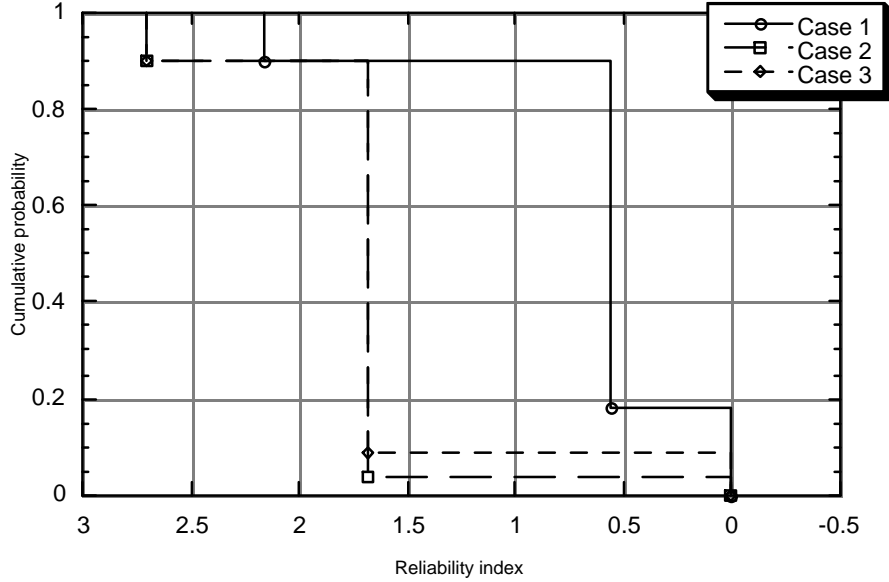

Figure 9. Reliability diagram for cases 1, 2 and 3.

7.2 Importance of variables

The importance of the basic variables is calculated for some of the scenarios. The importance measure used is the direction cosine for each basic variable which indicates the direction of the vector β in the standardised space. The vector β is directed as defined by equation 15. The direction cosines, in the vector \vec{a}_i , are results from the FOSM (or SOSM) method. The direction cosines can vary between -1 to 1 and are subjected to the condition described by equation 16.

$$\vec{x}_i = -\vec{a}_i \cdot \beta \quad (15)$$

$$\sum_{i=1}^n a_i^2 = 1 \quad (16)$$

where a_i indicates the different direction cosines and n is the number of basic variables in the limit state function. A high value of $|a_i|$ indicates a high importance for the basic variable.

In figure 10 the importance measure, a_i , is presented for a number of scenarios. The scenarios considered are those where the reliability index exceeds 0. The others are of no value as they are outside the validity of the method. It should be remembered that the importance factors can only be compared to each other within one specific scenario. There is only a weak link between the same

importance factor for different scenarios i.e. trends can be judged. The reason for this is that the importance measures are scaled so that the square root of the sum of the importance measures should equal one and they are obtained by information from one scenario at the time.

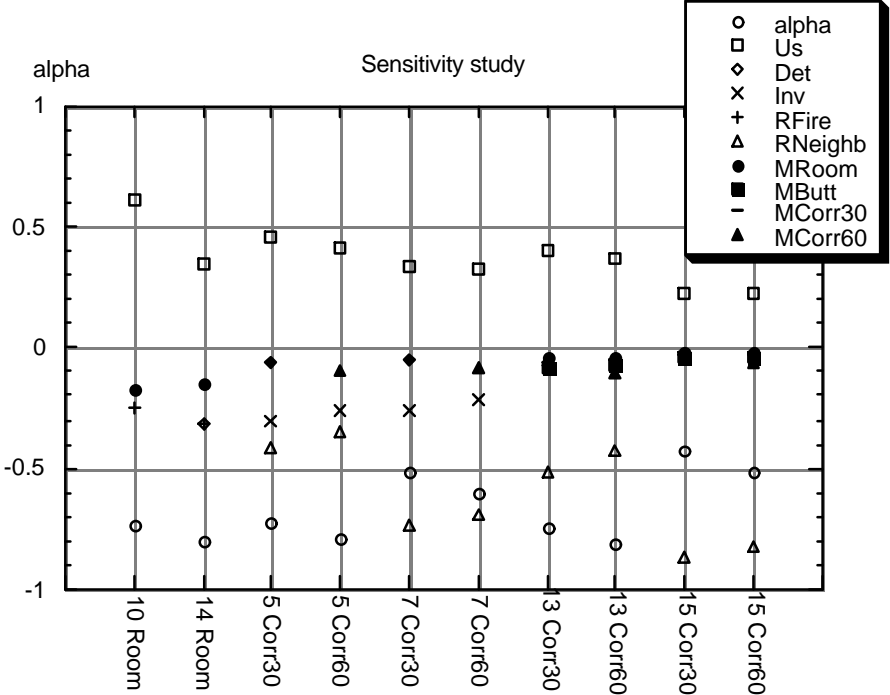

Figure 10. Importance of basic variables using standard parameters for the basic variables.

The data in the figure have been calculated using the standard parameters for the basic variables. It can be seen that the most significant variables are the fire growth rate and the model uncertainty parameter. These two are the only variables determining the available time and they therefore are likely to be of importance. Variables of minor importance are the walking times for the guests. Variations in these do not affect the reliability to any greater extent.

For the corridor cases, the response time of the guests in the neighbouring rooms show some significance. This can be explained by the choice of parameters and the reasons for these choices. By having better escape alarms resulting in less response time decreases the importance of this variable.

7.3 Design value of α

The FOSM method also provides the design point on the limit state function. Using the values at the design point results in the highest probability of having an unsuccessful evacuation. Plotting the calculated design values of the fire growth rate α , figure 11, shows that for scenarios 14 and 16 is the design value approximately 0.07 kW/s². This is a very fast fire growth rate resulting in

untenable conditions in less than one minute. If the actual fire growth rate is less than this value, the safety is increased.

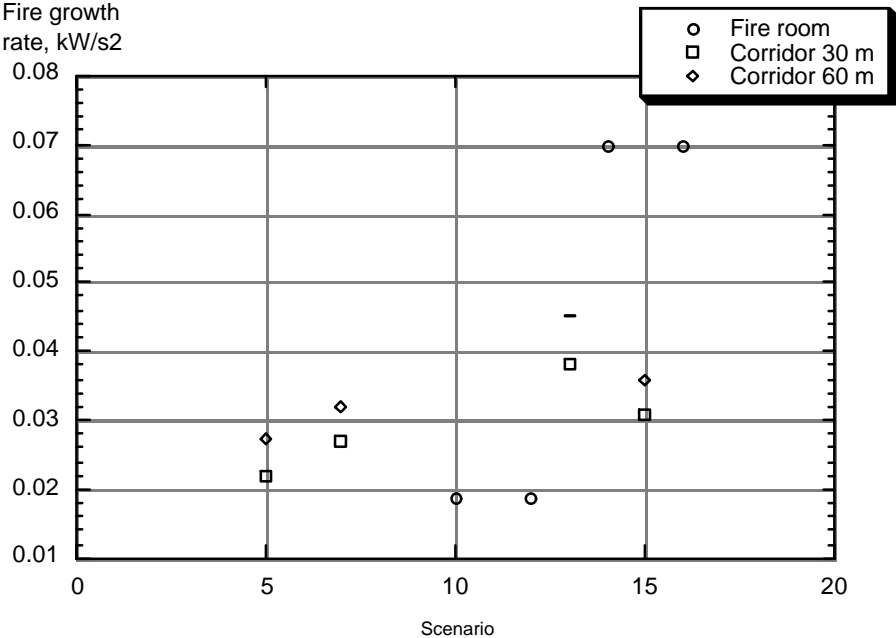

Figure 11. Design value for the fire growth rate derived with the FOSM method.

7.4 Sensitivity analysis

A brief sensitivity analysis was performed to see the influence on the reliability index if some parameters were changed. The variable concerned was the fire growth rate α . Two new descriptions of the variable were used with the parameters indicated in table 5.

Table 5. Parameters for a used in the sensitivity study. All values are in kW/s².

Sensitivity condition	Mean value	Standard deviation
K1	0.01	0.01
K2	0.02	0.005

The variable is still assumed to follow a lognormal distribution. As can be seen in figure 12, the value of β is increased as the fire growth rate is decreased, condition K1. The reason for this is that the time to untenable conditions is increased as the fire is developing slower. For the condition K1 only the mean value is changed from the standard condition. In condition K2 the standard deviation is decreased to half compared to the standard condition. The assumption behind this is to decrease the uncertainty for the variable α . By having less uncertainty it can be assumed that the β -value also should be increased. This is true for the scenarios where initial β -value is higher than

approximately 1. For the other scenarios, a lower β -value is achieved compared to the standard condition even when the uncertainty is decreased, figure 12.

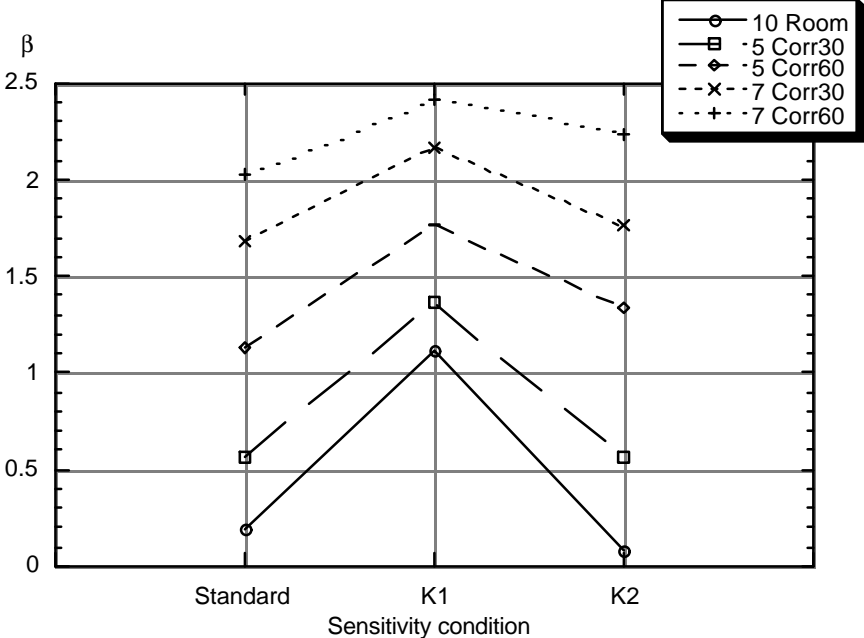

Figure 12. Reliability index β for the sensitivity study.

The importance measures for the basic variables are not drastically changed. The overall most important variables are still the fire growth rate of the fire and the model uncertainty factor for the smoke transport model, figure 13. For the corridor cases in scenario 7, the importance of the response time is rather high. This has to do with the relative high value of the mean for this variable compared to the other.

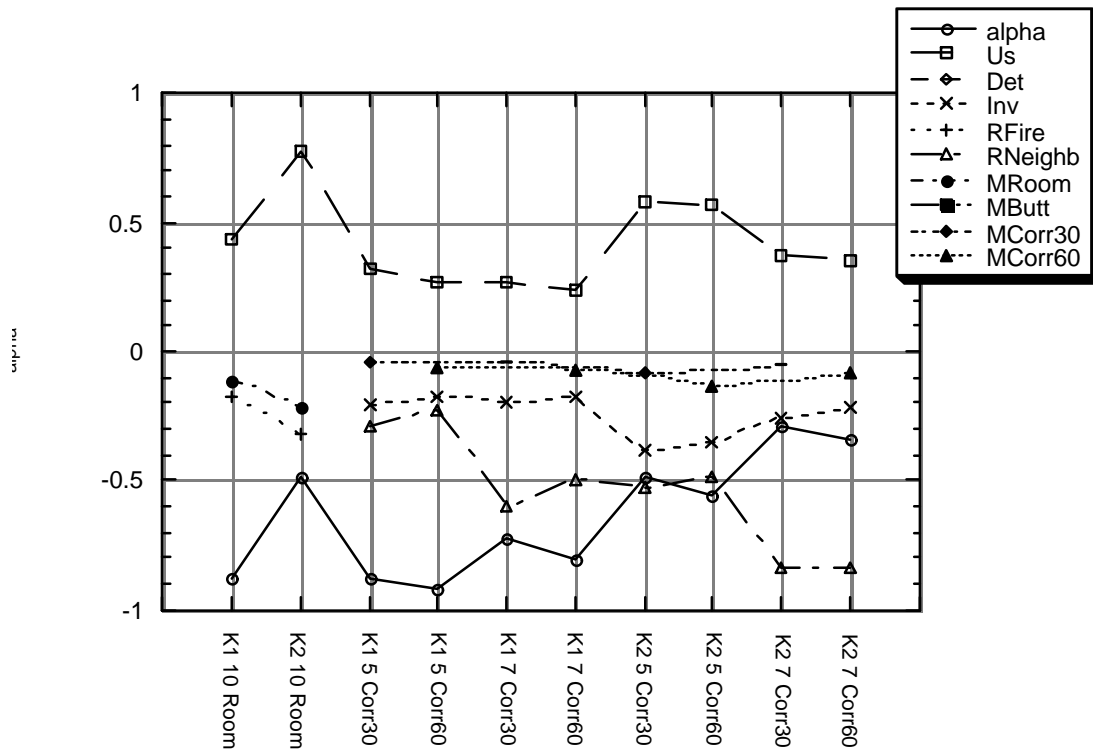

Figure 13. Importance of basic variables using the sensitivity conditions K1 and K2.

7.5 Societal risk

The societal risk is presented using F-N-curves. Practically all outcome scenarios are treated simultaneously and the result can be seen in the figures below. Four different conditions have been investigated. They differ in terms of the type of escape alarm system and the size of the corridor. As the size of the corridor is different so will also the probability of having an initial fire. The larger floor has twice the fire occurrence rate compared to the smaller one. The four conditions are:

Alarm bell in the 30 m corridor, $p_{\text{fire}} = 0.006$ per year.

Improved alarm in the rooms, 30 m corridor, $p_{\text{fire}} = 0.006$ per year.

Alarm bell in the 60 m corridor, $p_{\text{fire}} = 0.012$ per year.

Improved alarm in the rooms, 60 m corridor, $p_{\text{fire}} = 0.012$ per year.

As the total risk is derived it is also necessary to have some limit to compare the results with. In the Netherlands acceptable limits have been formulated for the societal risk, Vrijling et al. (1995). Political decisions have come to the conclusion that the death of 10 persons in case of failure of an LPG station could be accepted if the probability was less than 10^{-5} per year. For a higher number of deaths the accepted probability was less following the relationship

$$1 - F_N(x) < 10^{-3} / x^2 \quad \text{for } x > 10 \text{ deaths} \quad (17)$$

where F_N is the cumulative distribution function of the number of deaths resulting from the specific activity. This is the maximum level. A lower level is also defined below which no actions have to be taken to reduce the risk. Discussions concerning how the degree of voluntariness should be considered in the acceptable risk level are going on in the Netherlands as this factor is not included in the above relationship. The upper level from the Dutch decisions are also presented in the figures 14 - 17. If a design should be accepted the F-N-curve must fall below the limit.

As the number of calculated F-N-curves for each of the four conditions are high, 1000 iterations, not all of them can be presented. They do, however, together show how the uncertainty in the variables affect the uncertainty of the F-N-curve. To get a picture of the uncertainty of the F-N-curves, the 80 %-tile of the distribution of curves are presented together with the mean value. The 80 %-tile is calculated using a one-sided interval. This means that 20 % of the data is outside the limit.

The figures show that the mean value F-N-curve in most cases are below the Dutch limit. This is quite satisfactory. One should also bear in mind that the Dutch limit concerns the number of deaths. The affected persons in the present calculations do probably not die after the untenable conditions have occurred. There is a safety margin in the choice of untenable conditions. If untenable conditions subjected to uncertainty are used, a lower risk level can be expected in the hotel. This is not done within this work. For the last figure, note that the number of person scale is different. The mean value line for these scenarios indicates that there is always less than one person affected by the hazard.

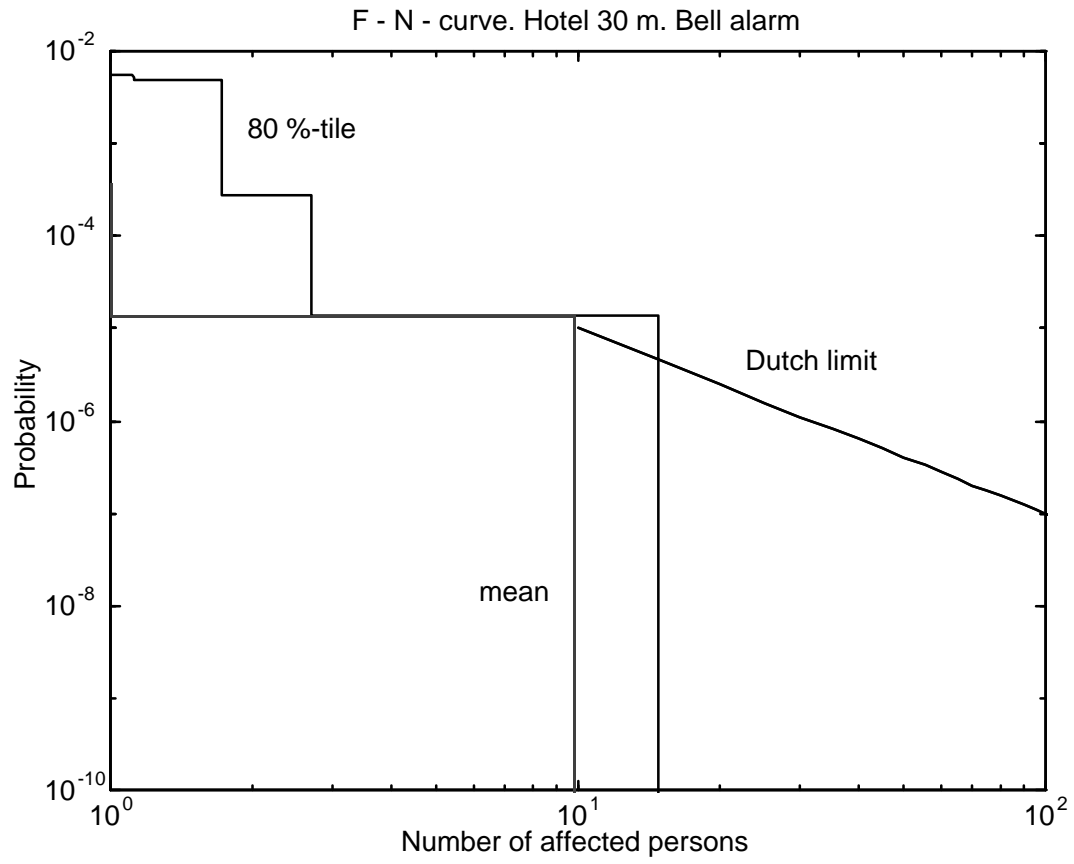

Figure 14. F-N-curve for 30 m hotel floor with bell alarm.

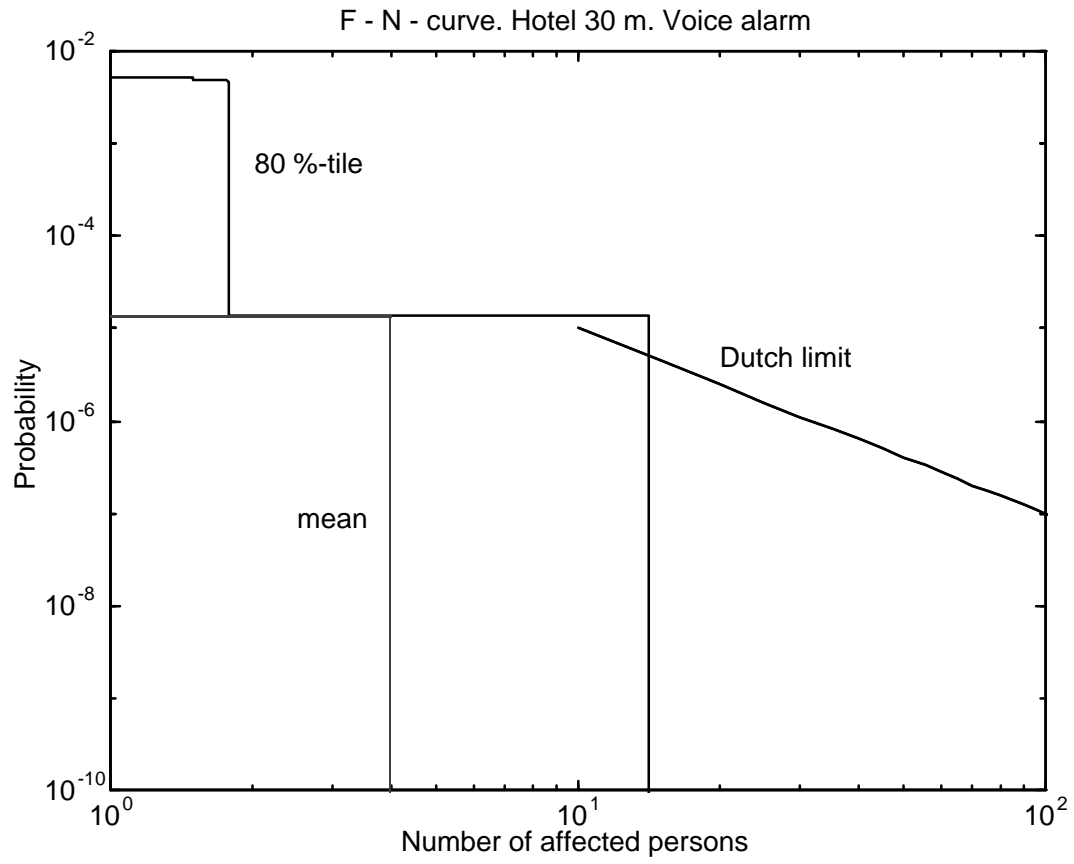

Figure 15. F-N-curve for 30 m hotel floor with improved escape alarm.

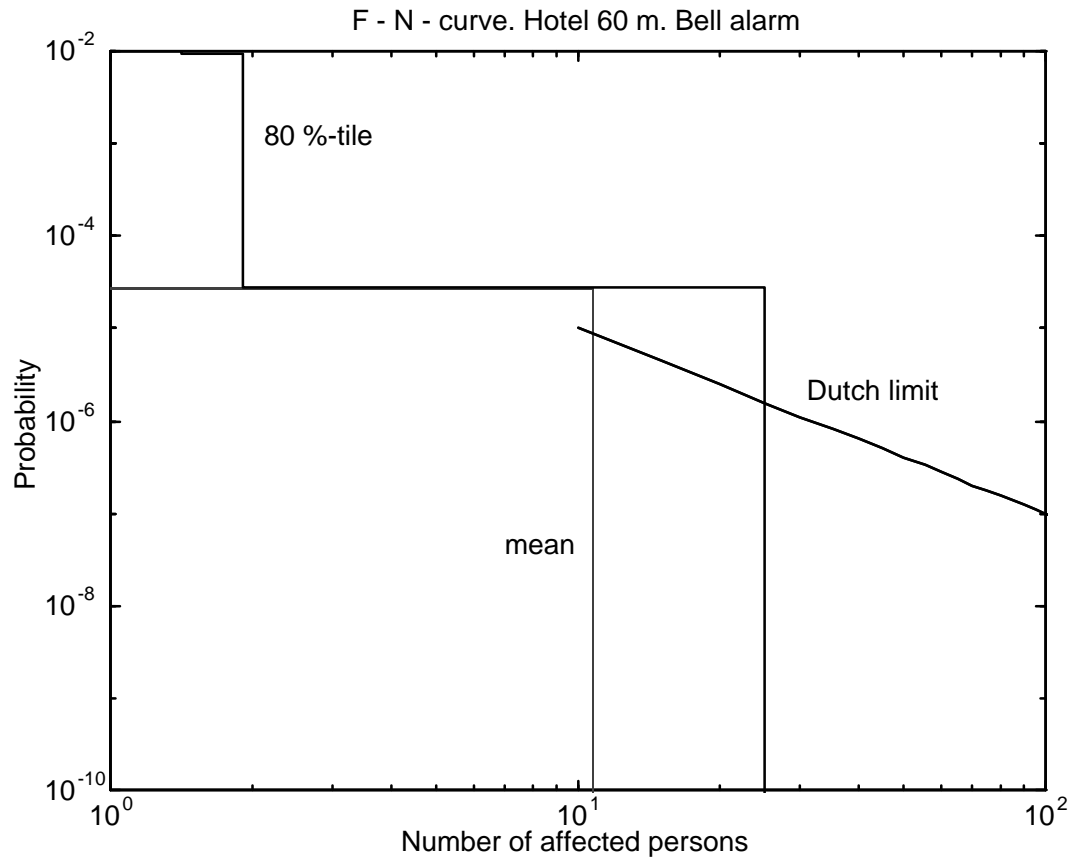

Figure 16. F-N-curve for 60 m hotel floor with bell alarm.

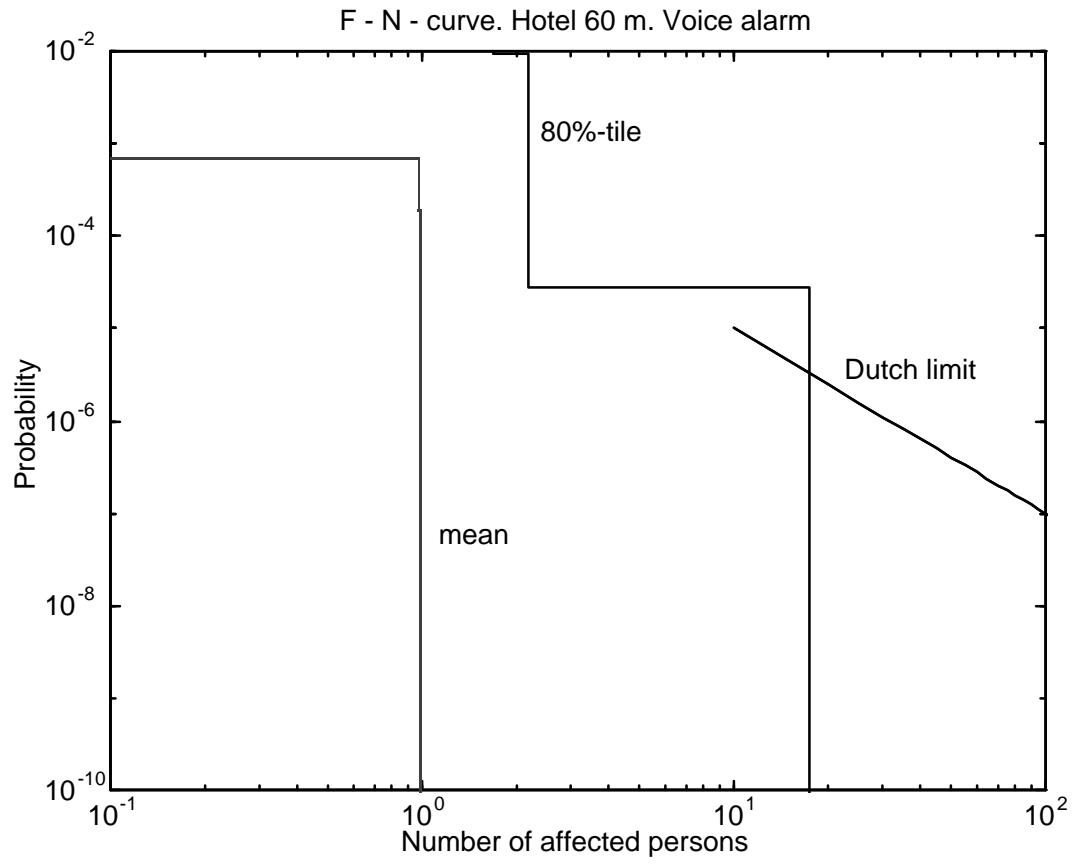

Figure 17. F-N-curve for 60 m hotel floor with improved escape alarm.

8 Conclusion

Most of the conclusions are already presented in the previous section, and it is clear that the methods can be used for this type of work.

The risk individual method i.e. the β -method, has been used for almost 20 years in the area of structural engineering. This is one of the first attempts made to treat the people safety with this method. Other examples where the method has been used can be found in Magnusson et al. (1994), Magnusson et al. (1995) and in Frantzich (1996). The method has been proven to result in a consistent reliability independent on how the limit state function is formulated. The method can be further used to derive safety factors or partial coefficients valid for a class of buildings, Frantzich et al. (1996) and NKB (1978). The procedure is to minimise the difference between a target β -value and the β -values for the scenarios in the class.

The advantage with the method is that it provides the design point, apart from the reliability index. The design point is a combination of values representing the basic variables that when used will lead to the desired reliability expressed as the β -value. In this report the information about the design point is not used more than to see the magnitude of one variable design value.

The most obvious disadvantage is that the method does not provide information about the frequency distribution for the limit state function. This information must be used to predict the risk to the society accurately. The information can be achieved by using numerical sampling methods to calculate the evacuation time margin. A comparison between the two methods will be presented in a later report. A simple treatment is provided in this report trying to establish a method to present the societal risk by using the reliability index and scenario probabilities.

The report does also present the risk to the society by using standard PRA techniques. This method has been used for many years mostly in the area of risk in process industries and nuclear facilities.

If the risk to the society is acceptable for a certain type of building after having conducted a PRA, the same values for the variables can be used to derive design values using the method for individual risk i.e. the β -method. A first step towards this has been taken in reference Frantzich et al. (1996).

Finally, the procedure presented in this report describes a method that can be used to calculate the reliability of safety expressed as the ability to evacuate safely from a building in the case of a fire.

Some general conclusions regarding the safety for guests in hotels, possible to use for practical purposes, can be stated.

The door between the guest room and the corridor is important. If that door can be kept closed during a fire in the room, no untenable conditions will occur in the corridor. It is therefore important to maintain the fire separating ability of the door and to secure the operation of the door closing device.

The ability to detect the fire by an automatic fire alarm is essential for the safety. A fast detection time will increase the time available for evacuation. The automatic fire detection is necessary if the person in the guest room on fire shall be able to escape. For this persons safety a direct alarm signal must be provided in the for that room. The signal must start as soon as the fire is detected.

A escape alarm with two different alarm signal types will result in a higher safety level. This is, however, a result from the choice of parameters for the variable. The other type of alarm signal, an alarm bell, results in a lower safety level.

The difference between the two proposed levels of untenable conditions does not affect the overall safety level considerably. An increased reliability index is achieved when the untenable levels are increased but not very much.

When an actual risk assessment of a hotel shall be performed, also the untenable conditions should be subjected to uncertainty. By using the two proposed levels of untenable conditions, results in a conservative safety level.

The fire growth variable α is the most important variable. This has to do with the large uncertainty connected to this variable.

9 Limitations

The calculations are subjected to some limitations.

All calculations are performed on a standardised hotel corridor configuration. This is however a minor limitation as most hotels in Sweden are planned in almost the same way. Usually hotel rooms are located on one or two sides of a corridor.

As the corridors in the calculations are rather long, 30 or 60 m some doubts can be raised about the validity of the calculations for smoke transport and the consequent time to untenable conditions. The model used to derive the time to untenable conditions is more suitable for smaller rooms. It assumes no horizontal smoke spread velocity as smoke is entering the corridor from the room. The smoke is instantaneously distributed under the ceiling in the corridor and the smoke layer starts to descend. This is not what can be expected from a real fire. To circumvent this, the corridor can be divided in smaller sections allowing for some time delay in the horizontal spread. The technique for doing this is, however, rather uncertain and is therefore not used.

No consideration has been taken to differences and dependence on whether conditions. It is generally known that pressure generated by the wind can alter the smoke spread completely. The wind generated pressure can become more dominant than the smoke induced pressure and force the smoke to enter areas which would not otherwise be contaminated. This fact has to be carefully investigated upon doing a fire risk analysis of a specific building.

The fire is always located in a guest room and does not spread to the corridor or to other guest rooms. The fire could of course spread out to the corridor if the door is kept open limiting the use of the corridor as a means of escape. The fire could also spread along the facade if the window breaks and through the ventilation system if the right conditions are available and the fire reaches a flash-over state. This has not been considered. A fire in another part of the building could jeopardise the evacuation from the guest rooms. For this case the fire or smoke must travel through fire separating walls and doors. The scenario is not unlikely. The conditions might not be different from those of a fire in a guest room but the scenario has not been examined.

Most of the data used for the calculations have been chosen according to judgement based on available statistics. If risk analysis for buildings shall be performed in a bigger scale better statistics is needed. Care should be taken if the data used in these calculations are to be applied to other building risk analysis.

10 Future work

The work of determining the risk to people due to fire is still in its initial stage. There are many items that must be considered to get a clear picture of the safety level of different types of occupancies. This publication together with the references Magnusson et al. (1995) and Frantzich (1996), both in the same series, tries to develop a rational procedure for deriving a measure of individual risk for a fire scenario. The presentation method for the risk measure is one matter that has to be evaluated.

To be able to fully consider the risk to individuals subjected to a fire hazard, several variables have to be specified. The statistical back-ground for these are probably existing but there is no structured database available. This means that many variables are subjected to an uncertainty that can be reduced by only organising the data in a proper way. The next step necessary, is to collect data to further reduce the uncertainty in the relevant variables.

Example of this type of variables are the reliability of a sprinkler system, the reliability of an automatic fire alarm, the responses to different kinds of escape alarms, the actions taken by staff at the location, considerations of various types of training levels of the staff and the different responses by occupants after hearing or seeing the escape alarm. A lot of work have been performed in these areas but the necessary numerical values are not available. What is needed is numerical values that can serve as a base for predicting the statistical frequency distribution for the variables. This means that it must at least be possible to derive the mean value and the standard deviation for each relevant variable.

Another variable that has to be further examined is the fire occurrence rate, or how likely is it that a fire really starts? This work has to be performed on a national level by collecting incident data from the whole country.

As this work is at the initial stage, some simplifications or limitations have been introduced. These are briefly discussed in the previous section. The limitations have to be considered in future calculations, to be able to make a better prediction of the safety level in various kinds of buildings. It must, however, be stated that the results presented in this report show the general trend for the safety level. A more detailed description of safety can be achieved by including those limitations as well. Some factors are still not possible to describe numerically and, therefore, have to be treated by other means for example by judgement.

Any future work should consider these suggestions to make a better prediction of the safety due to fire in buildings. The work has just started.

11 References

- Ang A. H-S., Tang W. H., Probability concepts in Engineering Planning and Design, Volume II. John Wiley & Sons, 1984.
- Bellamy L.L., Geyer T.A.W., Experimental programme to investigate informative fire warning characteristics for motivating fast evacuation. BR 172, British Research Establishment, Borehamwood 1990.
- Blomqvist J., Private communication, 1996.
- Brandsjö K., Hotel fire in Leningrad. Brand & Rädning No. 6-7, pp 10-13, 1991.
- Bryan J.L., An Examination and Analysis of the Dynamics of the Human Behavior in the MGM Grand Hotel Fire. National Fire Protection Association, Quincy 1993.
- Building Regulations 94, BBR94. The Swedish Board of Housing, Building and Planning (Boverket), Karlskrona 1994.
- Commission Electrotechnique Internationale - International Electrotechnical Commission CEI IEC 300-3-9, Dependability management - Part 3: Application guide-Section 9: Risk analysis of technological systems. CEI Genève 1995.
- Cornell C. A., A Probability-Based Structural Code. ACI-Journ., Vol 66. 1969.
- Covello V.T., Merkhofer M.W., Risk Assessment Methods, Approaches for Assessing Health and Environmental Risks. Plenum Press New York 1993.
- Draft British Standard Code of Practice for The Application of Fire Safety Engineering Principles to Fire Safety in Buildings, BSI 1994.
- Evaluating the Reliability of Predictions made using Environmental Transfer Models. Safety Series No. 100. International Atomic Energy Agency (IAEA), Vienna 1989.
- Evans D.D., Stroup D.W., Methods of Calculating the Response Time of Heat and Smoke Detectors Installed Below Large Unobstructed Ceilings. NBSIR 85-3167, National Bureau of Standards, Gaithersburg, 1985.
- Frantzich H., Fire Safety Risk Analysis of a Health Care Facility. Report 3085, Department of Fire Safety Engineering, Lund University, Lund 1996.
- Frantzich H., Holmquist B., Lundin J., Magnusson S.E., Rydén J., Derivation of Partial Safety Factors for Fire Safety Evaluation Using the Reliability Index β

Method. Accepted for publication at the 5th International Symposium for Fire Safety Science, 1996.

CPQRA, Guidelines for Chemical Process Quantitative Risk Analysis. Center for Chemical Process Safety of the American Institute of Chemical Engineers. New York 1989.

Hasofer A. M., Lind N. C., An Exact and Invariant First Order Reliability Format. Proc. ASCE, J. Eng. Mech. Div. 1974.

Helton J. C., Treatment of Uncertainty in Performance Assessments for Complex Systems. Risk Analysis, Vol. 14, No. 4, pp 483-511, 1994.

IAEA Safety Series No 100. Evaluating the Reliability of Predictions made Using Environmental Transfer Models. International Atomic Energy Agency, Vienna, 1989.

Magnusson S. E., Draft to evaluation of the Draft British Standard Code of Practice for The Application of Fire Safety Engineering Principles to Fire Safety in Buildings. Report 30??, Department of Fire Safety Engineering, Lund University, Lund 1996.

Magnusson S.E., Frantzich H., Karlsson B., Sårdqvist S., Determination of Safety Factors in Design Based on Performance. Proceedings of the Fourth International Symposium on Fire Safety Science. pp 937-948, Gaithersburg 1994.

Magnusson S. E., Frantzich H., Harada K., Fire Safety Design Based on Calculations, Uncertainty Analysis and Safety Verification. Report 3078, Department of Fire Safety Engineering, Lund University, Lund 1995.

Nordiska kommittén för byggbestämmelser (NKB), Retningslinjer for last- og sikkerhedsbestemmelser for baerende konstruktioner, NKB-rapport nr 35, Köpenhamn 1978.

Nybyggnadsregler, NR. Boverket, Karlskrona 1989.

Peacock R.D., Jones W.W., Forney G.G., Portier R.W., Reneke P.A., Bukowski R.W., Klote J.H., An Update Guide for HAZARD I Version 1.2, NISTIR 5410, National Institute of Standards and Technology, Gaithersburg 1994.

Purser D. A., Toxicity Assessment of Combustion Products. SFPE Handbook of Fire Protection Engineering, SFPE, Boston, 1988.

Rapport om brannen ved Hotel Caledonien i Kristiansand Fredag den 5 september 1986. Direktoratet for brann- og eksplosjonsvern (DBE) og Statens bygningstekniske etat, Oslo 1987. (In Norwegian)

Rutstein R., The estimation of the fire hazard in different occupancies. Fire Surveyor, Vol 8, No 2, pp 21-25, 1979.

Shields T.J., Dunlop K.E., Silcock G.W.H., Quantification of Emergency Egress Activities for Disabled People. University of Ulster, Carrickfergus 1995.

Standard for Automatic Water-sprinkler Systems, RUS 120:4. The Swedish Association of Insurance Companies, Stockholm 1993.

STRUREL, A Structural Reliability Analysis Program System, RCP, München, 1995.

Särdqvist S., Initial Fires, RHR, Smoke Production and CO Generation from Single Items and Room Fire Tests. Report 3070, Department of Fire Safety Engineering, Lund University, Lund 1993.

Thoft-Christensen P., Baker M. J., Structural Reliability Theory and Its Applications. Springer-Verlag, Berlin 1982.

Vrijling J. K., van Hengel W., Houben R. J., A framework for risk evaluation. Journal of Hazardous Materials 43, pp 245 261, 1995.

Appendix A

Description of the equations for the scenarios and the basic variables.

Basic variables

Variable	Standard scenario	Sensitivity study	Sensitivity study	Unit
α	Lognormal (0.02,0.01)	Lognormal (0.01,0.01)	Lognormal (0.02,0.005)	kW/s ²
Us	Normal (1.35,0.11)			-
tDet1	Uniform (120,300)			s
tDet2	Lognormal (15,3)			s
tInv	Lognormal (60,15)			s
RFire	Lognormal (15,3)			s
RNeighb1	Lognormal (120,20)			s
Rneighb2	Lognormal (60,30)			s
tMRoom	Uniform (3,8)			s
tButton	Uniform (5,15)			s
tMCorr30	Normal (20,3)			s
tMCorr60	Normal (37,6)			s

Limit state functions for 30 m floor plan

Scenario	LSF
1	$53.2 * \alpha^{-0.35} * Us - tDet1 - tInv - RNeighb1 - tMCorr30$
2	$11.5 * \alpha^{-0.44} * Us - tDet1 - RFire - tMRoom$
3	$53.2 * \alpha^{-0.35} * Us - tDet1 - tInv - RNeighb2 - tMCorr30$
4	$11.5 * \alpha^{-0.44} * Us - tDet1 - RFire - tMRoom$
5	$53.2 * \alpha^{-0.35} * Us - 20.6 * \alpha^{-0.3} - tInv - RNeighb1 - tMCorr30$
6	$11.5 * \alpha^{-0.44} * Us - 20.6 * \alpha^{-0.3} - tInv - RFire - tMRoom$
7	$53.2 * \alpha^{-0.35} * Us - 20.6 * \alpha^{-0.3} - tInv - RNeighb2 - tMCorr30$
8	$11.5 * \alpha^{-0.44} * Us - 20.6 * \alpha^{-0.3} - tInv - RFire - tMRoom$
9	$53.2 * \alpha^{-0.35} * Us - 20.6 * \alpha^{-0.3} - tInv - RNeighb1 - tMCorr30$
10	$11.5 * \alpha^{-0.44} * Us - 20.6 * \alpha^{-0.3} - RFire - tMRoom$
11	$53.2 * \alpha^{-0.35} * Us - 20.6 * \alpha^{-0.3} - tInv - RNeighb2 - tMCorr30$
12	$11.5 * \alpha^{-0.44} * Us - 20.6 * \alpha^{-0.3} - RFire - tMRoom$
13	$53.2 * \alpha^{-0.35} * Us - tDet2 - RFire - RNeighb1 - tMRoom - tButton - tMCorr30$
14	$11.5 * \alpha^{-0.44} * Us - tDet2 - RFire - tMRoom$
15	$53.2 * \alpha^{-0.35} * Us - tDet2 - RFire - RNeighb2 - tMRoom - tButton - tMCorr30$
16	$11.5 * \alpha^{-0.44} * Us - tDet2 - RFire - tMRoom$

Limit state functions for 60 m floor plan.

Scenario	LSF
1	$53.2 * \alpha^{-0.35} * U_s - t_{Det1} - t_{Inv} - R_{Neighb1} - t_{MCorr60}$
2	$11.5 * \alpha^{-0.44} * U_s - t_{Det1} - R_{Fire} - t_{MRoom}$
3	$53.2 * \alpha^{-0.35} * U_s - t_{Det1} - t_{Inv} - R_{Neighb2} - t_{MCorr60}$
4	$11.5 * \alpha^{-0.44} * U_s - t_{Det1} - R_{Fire} - t_{MRoom}$
5	$53.2 * \alpha^{-0.35} * U_s - 20.6 * \alpha^{-0.3} - t_{Inv} - R_{Neighb1} - t_{MCorr60}$
6	$11.5 * \alpha^{-0.44} * U_s - 20.6 * \alpha^{-0.3} - t_{Inv} - R_{Fire} - t_{MRoom}$
7	$53.2 * \alpha^{-0.35} * U_s - 20.6 * \alpha^{-0.3} - t_{Inv} - R_{Neighb2} - t_{MCorr60}$
8	$11.5 * \alpha^{-0.44} * U_s - 20.6 * \alpha^{-0.3} - t_{Inv} - R_{Fire} - t_{MRoom}$
9	$53.2 * \alpha^{-0.35} * U_s - 20.6 * \alpha^{-0.3} - t_{Inv} - R_{Neighb1} - t_{MCorr60}$
10	$11.5 * \alpha^{-0.44} * U_s - 20.6 * \alpha^{-0.3} - R_{Fire} - t_{MRoom}$
11	$53.2 * \alpha^{-0.35} * U_s - 20.6 * \alpha^{-0.3} - t_{Inv} - R_{Neighb2} - t_{MCorr60}$
12	$11.5 * \alpha^{-0.44} * U_s - 20.6 * \alpha^{-0.3} - R_{Fire} - t_{MRoom}$
13	$53.2 * \alpha^{-0.35} * U_s - t_{Det2} - R_{Fire} - R_{Neighb1} - t_{MRoom} - t_{Button} - t_{MCorr60}$
14	$11.5 * \alpha^{-0.44} * U_s - t_{Det2} - R_{Fire} - t_{MRoom}$
15	$53.2 * \alpha^{-0.35} * U_s - t_{Det2} - R_{Fire} - R_{Neighb2} - t_{MRoom} - t_{Button} - t_{MCorr60}$
16	$11.5 * \alpha^{-0.44} * U_s - t_{Det2} - R_{Fire} - t_{MRoom}$

For the sensitivity analysis, different equations can be used.