



LUND UNIVERSITY

Closed-Loop Combustion Control of a Multi Cylinder HCCI Engine using Variable Compression Ratio and Fast Thermal Management

Haraldsson, Göran

2005

[Link to publication](#)

Citation for published version (APA):

Haraldsson, G. (2005). *Closed-Loop Combustion Control of a Multi Cylinder HCCI Engine using Variable Compression Ratio and Fast Thermal Management*. [Doctoral Thesis (compilation), Combustion Engines]. Division of Combustion Engines, Lund Institute of Technology.

Total number of authors:

1

General rights

Unless other specific re-use rights are stated the following general rights apply:

Copyright and moral rights for the publications made accessible in the public portal are retained by the authors and/or other copyright owners and it is a condition of accessing publications that users recognise and abide by the legal requirements associated with these rights.

- Users may download and print one copy of any publication from the public portal for the purpose of private study or research.
- You may not further distribute the material or use it for any profit-making activity or commercial gain
- You may freely distribute the URL identifying the publication in the public portal

Read more about Creative commons licenses: <https://creativecommons.org/licenses/>

Take down policy

If you believe that this document breaches copyright please contact us providing details, and we will remove access to the work immediately and investigate your claim.

LUND UNIVERSITY

PO Box 117
221 00 Lund
+46 46-222 00 00

HCCI Combustion Phasing with Closed-Loop Combustion Control Using Variable Compression Ratio in a Multi Cylinder Engine

Göran Haraldsson, Per Tunestål and Bengt Johansson
Division of Combustion Engines, Lund Institute of Technology

Jari Hyvönen
Saab Automobile Powertrain

Copyright © 2003 Society of Automotive Engineers of Japan, Inc.

ABSTRACT

This study applies Closed-Loop Combustion Control (CLCC) using Variable Compression Ratio (VCR) and cylinder balancing using variable lambda to solve the problem. Step changes of set points for combustion phasing, Compression Ratio (CR), and load together with ramps of engine speed and inlet air temperature are investigated. Performances of the controllers are investigated by running the engine at either a constant amount of injected fuel corresponding to an approximate load of 1.5 or 2.5 bar BMEP and/or constant speed of 2000 rpm. Commercial RON 92 gasoline is used in the test. The CLCC is found to be fast and effective and has a potential of handling step changes in a matter of cycles, while the speed and temperature ramps need some more optimization of the CLCC. The CR controller is very fast and has a time constant corresponding to three engine cycles at 2000 rpm.

INTRODUCTION

The Homogeneous Charge Compression Ignition (HCCI) engine can be understood as a hybrid between the Spark Ignition (SI) and Compression Ignition (CI) engines. In the SI engine, fuel and air are mixed homogeneously before combustion initiation. The charge is then compressed and ignited by a spark plug at the most convenient time for the combustion process. To control the load of an SI engine, a throttle is used to adjust the amount of mixed air and fuel that enters the cylinder.

In the CI engine, air is compressed to a higher pressure than in the SI engine, and fuel is injected at high pressure into the hot compressed air and auto-ignition occurs. By adjusting the amount of injected fuel, the load is controlled and hence no throttling is necessary. HCCI engines use a premixed air and fuel mixture like the SI engine and compress this mixture to auto-ignition like the CI engine. There are various

parameters to take into account in order to obtain HCCI combustion. Temperature and pressure in the cylinder at the end of the compression stroke, auto ignition properties of the fuel and amount of residual gas all affect the HCCI ignition process. The temperature of the charge has to be higher at the end of the compression phase, compared to the SI engine, in order to cause auto ignition with conventional SI engine fuels.

The first presented results of HCCI engines were performed on 2-stroke engines [1-2]. The primary purpose of using HCCI combustion in 2-stroke engines is to reduce the HC emissions at part load operation, and to decrease fuel consumption by stabilizing the combustion of diluted mixtures. In four-stroke engines, auto ignition can be achieved through a high Compression Ratio (CR), pre heating of the inlet air or use of retained residuals [3-9]. In two-strokes, residual gas is always present because of incomplete scavenging, and therefore no pre heating is necessary. For 4-stroke engines, HCCI has the potential of combining the desirable features of SI (low NO_x and particulates) with the desirable features of CI (high efficiency through low pumping losses and high CR).

The low combustion temperature and higher CR with HCCI combustion leads to higher HC and CO emissions than from SI and CI engines [10]. The low exhaust gas temperature is also a problem for the catalyst, since a fairly high temperature is needed to start the oxidation. Another drawback is the very high heat release rate, which leads to high maximum pressures and noise levels. To avoid too fast combustion, a diluent must be used. The diluent can be any combination of air, residual gas and Exhaust Gas Recirculation (EGR). In four-strokes, EGR is used both as a diluent to slow down combustion and as bulk to control the temperature of the intake mixture. Since the onset of combustion depends on temperature, pressure, and mixture formation in each cylinder, controlling the combustion process is a

challenge. One way to monitor the onset of combustion is to measure the cylinder pressure in each cylinder and calculate the accumulated heat release online. The Crank Angle of 50% heat release (CA50) then serves as a quantitative measure of the combustion phasing [11]. Opened-loop combustion phasing using Variable Compression Ratio (VCR) is shown in earlier papers [10,12-14] to result in a large operating range for HCCI, and CR as high as 21:1 is effective [14].

One of the main difficulties with the HCCI engine is combustion control. The engine of the present study has VCR as a means to phase the combustion. The control has to be fast and some kind of computer is necessary. Our solution is a Closed-Loop Combustion Control (CLCC) system where a mean CA50 for all cylinders is used as feedback for control. The high bandwidth variable to adjust is then the CR. Other variables like inlet air temperature and lambda are of course possible to use but they are either not as fast or have some undesirable effects.

The objective of this study is to show the performance of a CLCC system using VCR to keep a desired CA50 and a cylinder balancing control, which adjusts the cylinder individual CA50 to the global set point of CA50. The control system is explained mainly where there is new and improved functionality compared to the original program developed by Olsson et al. [11,15].

EXPERIMENTAL APPARATUS

THE ENGINE

The engine used is a five-cylinder 1.6L Saab Variable Compression (SVC) prototype engine. This engine is the basis for a downsized highly boosted SI engine concept [16]. The engine VCR mechanism can be seen in Figure 1 and its specifications are given in Table 1

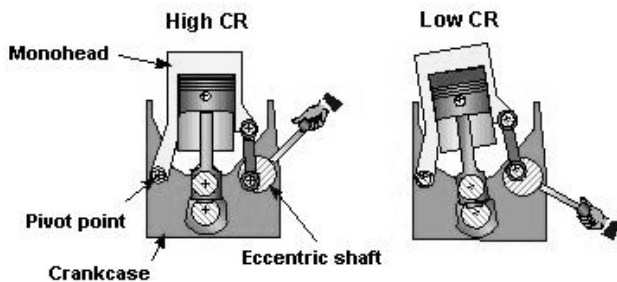

Figure 1 Saab Variable Compression (SVC) engine [16].

The geometric CR can be varied continuously between 9:1 and 21:1 by tilting the upper part of the engine up to approximately four degrees by rotating the eccentric shaft. The eccentric shaft is turned by a hydraulic actuator, which is shown in Figure 2. The engine is run naturally aspirated during the tests presented in this paper.

Table 1 Geometric specifications of the engine.

Displacement	1598 cm ³ (320 cm ³ /cyl)
Number of cylinders	5
Compression Ratio	Adjustable 9–21:1
Bore x Stroke	68mm x 88mm
Exhaust valve open	45°BBDC at 0.15mm lift
Exhaust valve close	7°ATDC at 0.15mm lift
Inlet valve open	7°BTDC at 0.15mm lift
Inlet valve close	49°ABDC at 0.15mm lift
Combustion chamber	Pent roof

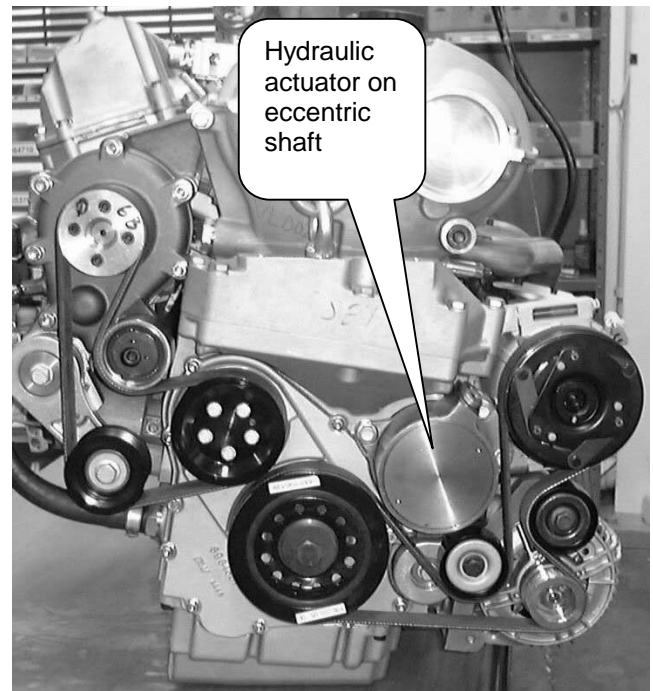

Figure 2 Front end of SVC engine with hydraulic actuator.

An electrical inlet air pre-heater of 11 kW is fitted in the air inlet of an advanced heat recovery system between the air filter and the inlet air manifold [14]. The heat exchanger, catalyst and the other components can be seen in Figure 3. The catalyst is a standard three-way catalyst used on a Saab 9-5 model, but since no emissions are measured for these tests, conversion efficiency cannot be calculated.

The cylinder pressures are monitored with water-cooled cylinder pressure sensors from Kistler, model 6043A fitted in custom made holes in the cylinder head one for each cylinder. Due to the high CR, which does not leave any room for the original spark plugs, the spark plugs are removed and blinds are fitted in the holes. It is possible to use other spark plugs with shorter center electrode to cold start the engine in SI and then mode switch to HCCI without the use of electrical inlet air heating as is presently used for startup.

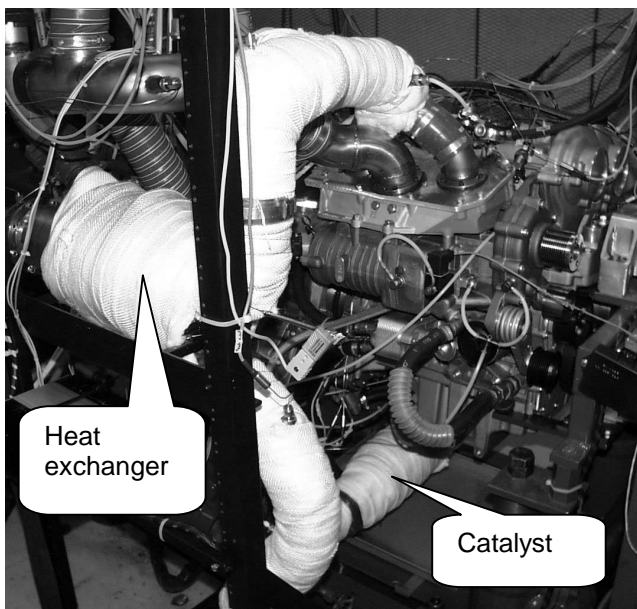

Figure 3 SVC engine with heat recovery system.

DATA ACQUISITION HARDWARE

Sampling rate

All sampling is crank angle based. A LEINE & LINDE crank angle encoder with 1800 TTL pulses per revolution is used as clock. The encoder also supplies one TTL pulse per revolution that is used as a trigger for the start of sampling. The trigger is adjusted to Top Dead Center (TDC), which of course happens two times per engine cycle but only one of them is used. A common solution is to mask gas exchange TDC by checking the position of the camshaft. Since no easy solution is found on this engine, due to difficulties in connecting something on the camshaft end, a manual switch is used. If the wrong TDC is found, the program is stopped and the switch is toggled. All sampling is done during a complete engine cycle, which here is defined as two revolutions of the engine consisting of five combustion events.

Cylinder pressures

A multiplexed 16 bit A/D-converter, Wavebook 516 with simultaneous sample and hold from IOtech, capable of 1M samples/s is used to sample the cylinder pressure. The sample rate is 5 samples per Crank Angle Degree (CAD) per cylinder for engine speeds below 3000 rpm and 2.5 samples per CAD per cylinder above 3000 rpm due to limited data transfer rate to the PC. The Wavebook is connected to the computer through an ISA parallel port card from IOtech. With this configuration a maximum total transfer rate of approximately 600k samples/s is reached. It is found that the currently used 1GHz Pentium III PC with 512MB RAM actually reaches lower theoretical maximum speed on the parallel port than a previous 667MHz PC which theoretically could handle the full speed. The lower spec PC, however, was limited in processing capabilities.

Other input and output

Inlet air pressure, inlet air temperature before and after heater, and CR, is logged with a multi function multiplexed 16-bit PCI card, NI6052E from National Instruments (NI). The sampling rate is chosen to be one tenth of the sampling rate for the cylinder pressure. The divider is a hardware divider outside the PC, since earlier tests showed significant instability when using the software divider supported by NI. The maximum total sampling rate for the NI6052E is 333k samples/s.

All outputs are set from this card except injection of fuel, which is discussed in the next paragraph. The electrical inlet air pre-heater and the hydraulic valve for CR use the two available analog output channels. Two digital output lines are used, one to enable/disable the supercharger, which is not used in this test. The other is used for enabling the external trigger. This allows both A/D-converters to start simultaneously and sample continuously until the program is terminated. Sampling starts at gas exchange TDC by one TDC trig.

Injection

The injection system is based on an in house made device with three cards that consist of six PIC 16F84A processor chips each. Communication to the PICs is made through the PC's original parallel port. Each individual PIC can be accessed and programmed at any time. With this system it is possible to control the time when injection starts and the duration of the injection cylinder by cylinder. The PIC uses the external encoder for phasing and an internal clock for timing of the duration and continues until terminated or reprogrammed. Having a standalone fuel injection system is found to be very useful when doing control experiments and especially with a Windows based operating systems.

CONTROL SYSTEM

SOFTWARE

The control program is written mainly by Olsson et al. [11] in Borland Delphi, but rewritten for this engine. The main differences are crank angle based measurement of inlet temperature, inlet pressure and CR. Olsson used dual fuel controlling combustion phase with the ratio of two fuels. We use CR instead. Each of the two A/D-converters has its own thread and when there is at least one complete cylinder cycle i.e. one combustion event available in the buffers, the calculation thread takes care of the data and calculates the status of the engine, i.e. CR, CA50, COV IMEP, IMEP net, peak cylinder pressure etc. for that specific cylinder. When there is more than one complete engine cycle in the buffers, the calculation thread skips the old and uses the most recent data to control the engine. Typically, less than every second cycle is thrown away. When calculation is done, the controllers receive the data and calculate output for CR, inlet air heater and injectors. For the screen update there is another thread that plots cylinder pressure, apparent heat release and the values of the

different alarm variables. The PID controller is a procedure common to all control loops while the parameters are not. Figure 4 shows a schematic of the control and measurement system.

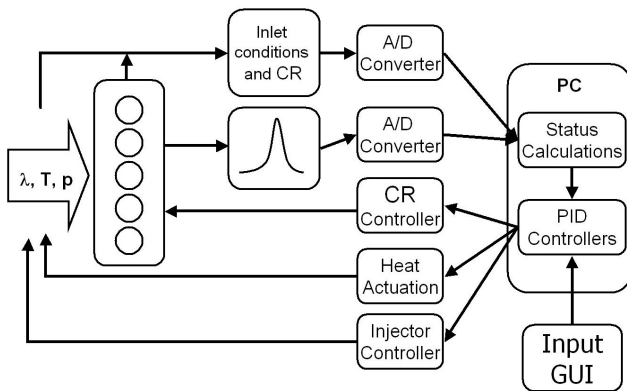

Figure 4 Schematic of control and measurement system.

The user clicks a button on the GUI to save a given number of engine cycles. The data calculated by the calculation thread and other variables set in the controller is saved for every cylinder cycle, i.e. five times per engine cycle. Sometimes the calculation thread cannot keep up with the engine and then there is a gap in the file, where data is thrown away. Data saving of binary data for post processing is saved for all engine cycles, hence no gaps. Binary pressure data is saved for each cylinder at a resolution dependent on engine speed. The other binary saved variables are temperature before and after inlet air heater, CR and inlet manifold pressure.

COMPRESSION RATIO

For CR control, an ATOS proportional directional hydraulic valve of type DLHZO is used. This valve has an internal control loop and very small dead band, which is needed to be able to fine tune the CR and still have a fast response. The valve uses -10 to $10V$ as input, which is proportional to a position and hence oil flow for the valve. The rest of the hydraulic system consists of a pump, which delivers oil to an accumulator tank.

On the engine, a hydraulic actuator is connected to the eccentric shaft, which is seen in Figure 2. This actuator rotates the eccentric shaft. As feedback for the control loop, the position is measured and calculated from an angular sensor connected to the eccentric shaft. The value is then converted to a CR in the PC according to Figure 5. The controller for CR is a PID controller. All CR values given in this paper are geometric CRs, which is not always the same as the effective CR due to inlet valve closure timing [14].

Gain scheduling is used for the proportional part of the PID controller i.e. the proportional gain is a function of another variable, here CR. This is necessary due to the behaviour of the eccentric shaft and other parameters, which affect the performance of the CR controller. Below are some of the variables that affect the CR control:

- Non-linearity of VCR mechanism
- Engine speed and load
- Hydraulic pressure and temperature
- Hysteresis /play of position sensor

The only parameter taken into account in this test is the non-linearity of the CR mechanism, shown in Figure 5, since it is found to be the one with dominating impact on performance for this test. The engine speed has some impact on the controller since the set point for CR is updated on crank angle basis. Due to lack of time and the intention to run the engine at constant speed for almost all test cases, no mapping of the CR control is done with respect to speed. The control works for more than one speed, but for a more accurate control, speed must be taken into account. Mapping of the control parameters is done by optimizing the parameters for each integer CR. The Ziegler-Nichols method [17] is used to provide a starting point for the control parameter optimisation. Trial and error type iteration is then used to fine-tune the controller. The chosen parameters are then used in the program by interpolation for a given set point of CR.

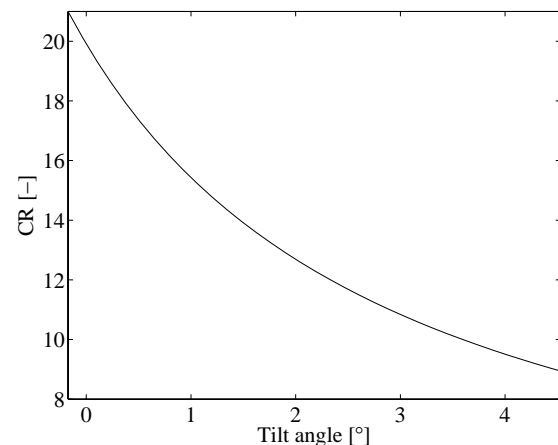

Figure 5 CR as a function of tilt angle of the monohead for the SVC engine.

INLET AIR HEATING

The inlet air heating system consists of an electrical 11kW heater, a heat recovery system with a heat exchanger and a couple of throttle valves. The valves can be adjusted manually by potentiometers. One valve controls the flow of hot air and another the flow of cold air. This setup enables controlled mixing of hot and cold air as well as addition of heating power from the electric heater during startup. The electrical heater is primarily controlled by a REGIN driver, that with an input of 0 to 10V, creates a PWM signal with a cycle time of 1s, which turns the heater on at zero volt and off at zero amps. For control of the electrical inlet air heater, the temperatures before and after the heater are measured. The temperature before the heater is used together with engine speed and inlet pressure for feed forward control of inlet temperature. The PID controller uses the temperature after the heater as

feedback. Type K thermocouples with transmitters are used for these measurements. The derivative part of the PID controller is not used for temperature control.

LOAD

Load is controlled from the program by adjusting the injected amount of fuel heat and this can be adjusted individually for each cylinder. IMEP net is calculated for each cylinder but no controller is used for setting the load.

CYLINDER BALANCING

A very large difference in combustion phasing between the cylinders is shown in Figure 6. The load is set to 2.5 bar BMEP at an engine speed of 2000 rpm. The difference in inlet air temperature between cylinder 1 and 5 in the middle plot is 9°C, which is equivalent to 2.3 CAD difference in CA50 for this engine. The large difference in inlet air temperature is due to poor mixing of hot and cold air in the inlet manifold. Flowers et al. [18] explained their cylinder-to-cylinder difference by the cooling waters longitudinal flow direction through the engine. This is not the case with the SVC engine though.

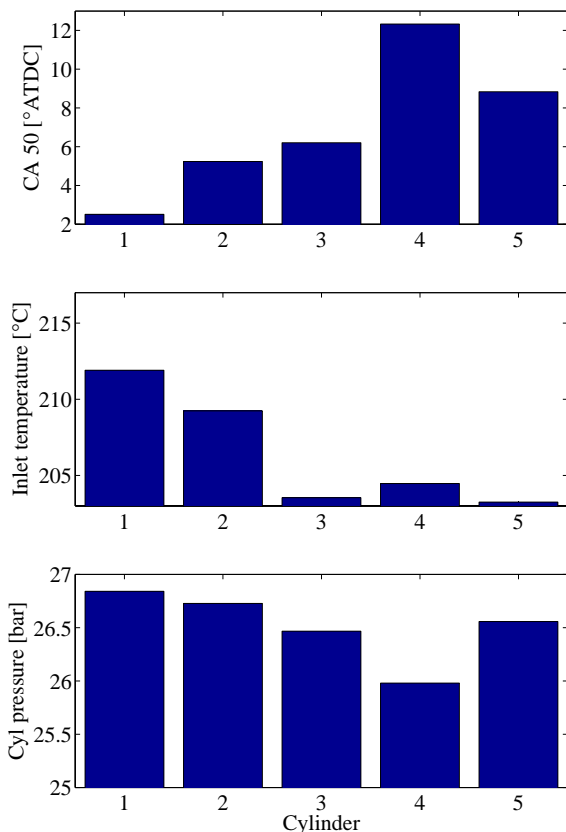

Figure 6 Cylinder to cylinder variations with no cylinder balancing and CLCC at 2000 rpm and 2.5 bar BMEP.

The difference in CA50 between cylinder 1 and 5 in the upper plot is 6.3 CAD, which means that additionally 4 CAD, has to derive from differences in cylinder pressure at start of combustion, if cylinder

wall temperature and piston cooling is believed to be even between the cylinders. The mean cylinder pressure at 8 CAD BTDC, before combustion starts, in the lower plot is a measure of effective CR and other tuning effects. The deviation in CR is due to tolerance in the machining [14]. Since the CR is a global control parameter, it is necessary to balance the cylinder-individual combustion phasing by other means. One solution is to allow differences in lambda and hence IMEP between the cylinders.

In the calculation thread, CA50 is calculated for each cylinder together with a mean value for all cylinders. The deviation from the mean value of CA50 is then calculated for each cylinder and an offset in percent from the injected amount of fuel is set. The offset is calculated so the total amount of fuel is kept constant. The controller for the cylinder balancing uses the integral part only. Figure 7 shows a schematic of the cylinder-balancing controller

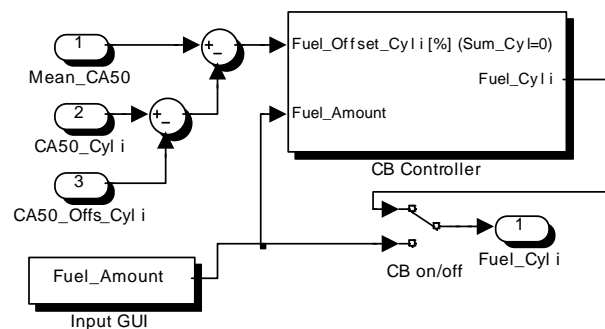

Figure 7 Cylinder balancing controller.

It is also possible to offset the set point for CA50 for each cylinder manually. This is useful when there are large differences in air temperature between the cylinders. If for example one cylinder receives very much colder air than the others do, the cylinder balancing will then add more fuel to keep CA50. This will result in higher load and sometimes an excessively high load. It is then useful to allow later combustion phasing. At light load, the cylinders all run with the same CA50 but if the cylinder balancing has decreased fuel to one cylinder it could be very close to misfire. It is then advantageous to phase that cylinder earlier than the others.

CLOSED-LOOP COMBUSTION CONTROL

The calculation thread calculates a mean CA50. This is used as input to the PID controller. The controller then sets a new set point for the CR, which is used as input for the CR controller. The CLCC system of cascade coupled compression ratio and CA50 controllers is shown in Figure 8. If the CLCC switch is turned off, CR can be adjusted manually. For the CLCC all parts of the PID controller are used. In all steps and ramps, the CA50 set point is set to 7 CAD ATDC except for the CR and CA50 steps and the cylinder balancing test, where the CLCC is not enabled. The CLCC's task is to keep a desired CA50 at all times by adjusting the CR even though other variables might change.

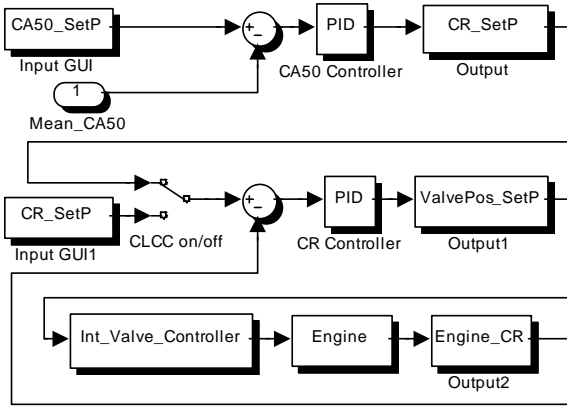

Figure 8 The CLCC system of cascade coupled CR and CA50 controllers.

RESULTS

COMPRESSION RATIO STEP RESPONSE

To test the performance of the CR controller, step changes from 17.7 to 16.7 and back to 17.7 in the CR set point are performed. Speed, inlet air temperature and injected amount of fuel are kept constant. The result of these steps is seen in Figure 9, where a cycle is defined as two revolutions of the engine consisting of five combustion events.

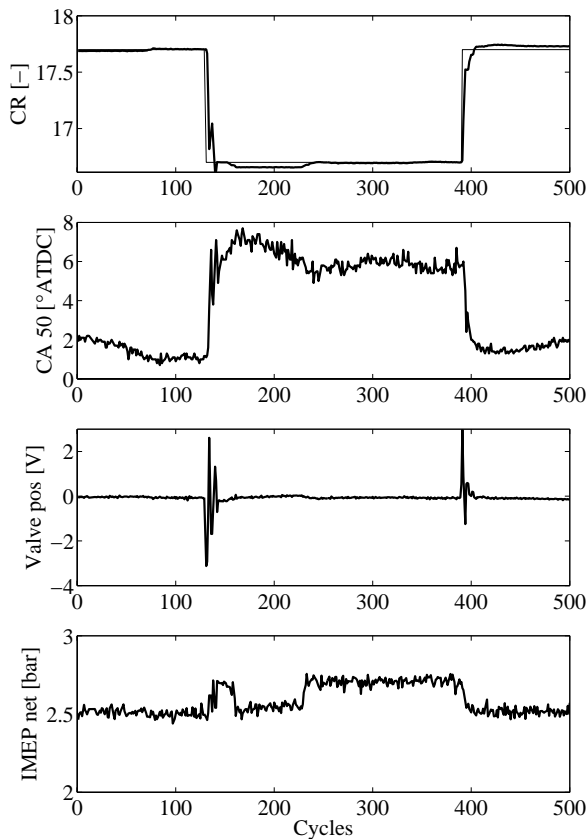

Figure 9 Step response of CR step from 17.7 to 16.7 and back to 17.7 at 2000 rpm and 1.5 bar BMEP.

The top graph shows with a thin line the set point and with a thick line the actual value of the CR as a function of engine cycle number. In the second it is shown how much the uncontrolled mean CA50 changes with such a step. The mean CA50 typically fluctuates two CAD at this speed and load without CLCC. This is the main reason why mean CA50 is not an exact inverse of the CR curve. The third graph shows the output signal to the hydraulic valve. In the bottom graph IMEP net is plotted. Five hundred engine cycles are shown which is equivalent to 30s at 2000 rpm. The faster negative step response is somewhat bumpy, while the slower positive is smoother with a time constant of three engine cycles i.e. the time, which is needed to reach 63% of the set value. Three engine cycles at 2000 rpm is equivalent to 180ms. The mean rate of CR change (dCR/dt), is then 3.5 CR units per second. IMEP net is affected to some extent by the rapid changes of CR with a COV IMEP of 3.6% for the entire transient compared to 1% before engine cycle 130. At engine cycle 129 IMEP net increases by approximately 0.2 bar, but returns to its initial value when CR returns to 17.7. Figure 10 shows a close-up of the positive step from Figure 9.

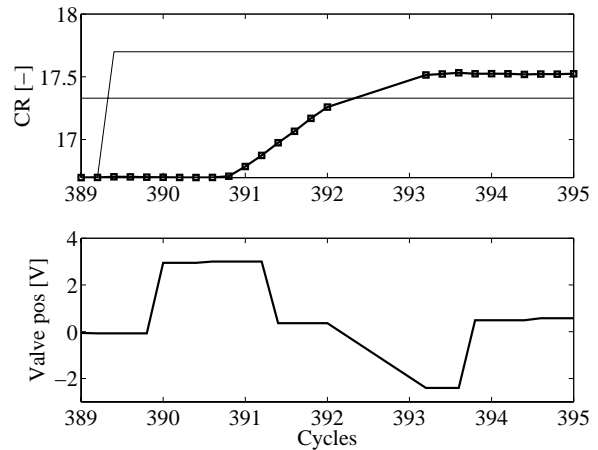

Figure 10 Close-up of positive step change on CR set point at 2000 rpm and 1.5 bar BMEP.

The gap in the measured points in Figure 10 is due to the fact that the program typically calculates 75% of the engine cycles at 2000 rpm and here one engine cycle is missing. Remember it is a multi cylinder engine and a combustion event represents combustion in one cylinder and there is then five combustion events in one engine cycle for a five cylinder engine. On the third combustion event of engine cycle 389, the set point for CR is changed and three combustion events later, the valve output is changed. Approximately on the third combustion event of engine cycle 392, the measured CR reaches the line for 63% of the set point. This means it takes three combustion events, which is equivalent to 36ms for the software to change the output to the hydraulic valve and the hardware needs an additional 144ms to reach 63% of the set point. This is discussed in more detail above under the software paragraph. The output to the hydraulic valve is quite modest, +3 down to -2.4, for such a large step in the set point, which is, as shown in Figure 9, equivalent to a change of approximately six CAD in CA50. The remaining error at engine cycle 394 can partly be explained by

hysteresis in the position sensor for tilt angle of the monohead. Another reason is the need for a more complex and fine tuned control, which should take into account all the dependent variables mentioned under the compression ratio paragraph.

CYLINDER BALANCING PERFORMANCE

A large difference in CA50 between the cylinders is a limitation for higher load. The need for balancing is very clearly shown in Figure 6 and Figure 11, where the engine is run at 2.5 bar BMEP and 2000 rpm without any cylinder balancing or CLCC for the first 112 engine cycles. The cylinder balancing is turned on at engine cycle 112 and the deviation reaches a minimum steady state value 28 engine cycles later, which is equivalent to 1.7s at this speed. The maximum allowed fuel offset is chosen to be 30%. Without this limit, IMEP net would deviate excessively.

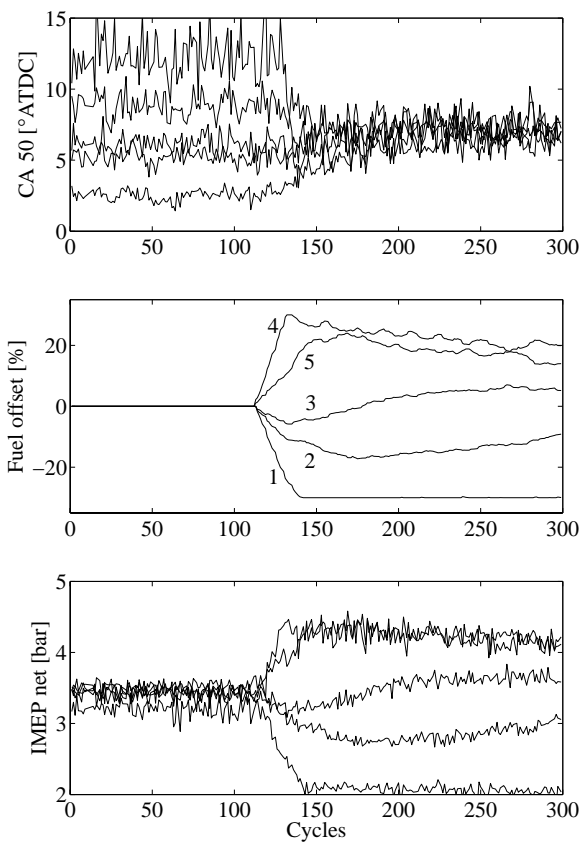

Figure 11 CA50, fuel offset and IMEP net for all cylinders at 2000 rpm and 2.5 bar BMEP.

The plot of fuel offsets, shows that at first the offset has to be higher than the final value. This is due to the inertia in wall temperature. The IMEP net difference goes from 0.5 to 3 bar, which for cylinder 1 results in a lower IMEP net than the fuel offset indicates, due to poor combustion efficiency. This of course results in differences in emissions, noise etc between the cylinders as well. For this case, it would be beneficial to set an offset on CA50 between the cylinders as discussed earlier. No offsets are set here though in order to clearly show the performance of the cylinder-balancing controller. This kind of cylinder balancing

control is useful for fine-tuning CA50, but other measures should be taken to smooth cylinder individual CR and inlet air temperature to minimize the need for cylinder individual lambda control.

CLOSED-LOOP COMBUSTION CONTROL

Response to step changes in CA50 set point

CLCC is necessary to reach higher loads and run the engine under transient conditions. With a step in the set point for CA50 the performance of the CLCC using VCR is tested for a constant load of 1.5 bar BMEP and a speed of 2000 rpm. Figure 12 shows the measured CR with a thick line and CR set point with a thin line in the upper plot.

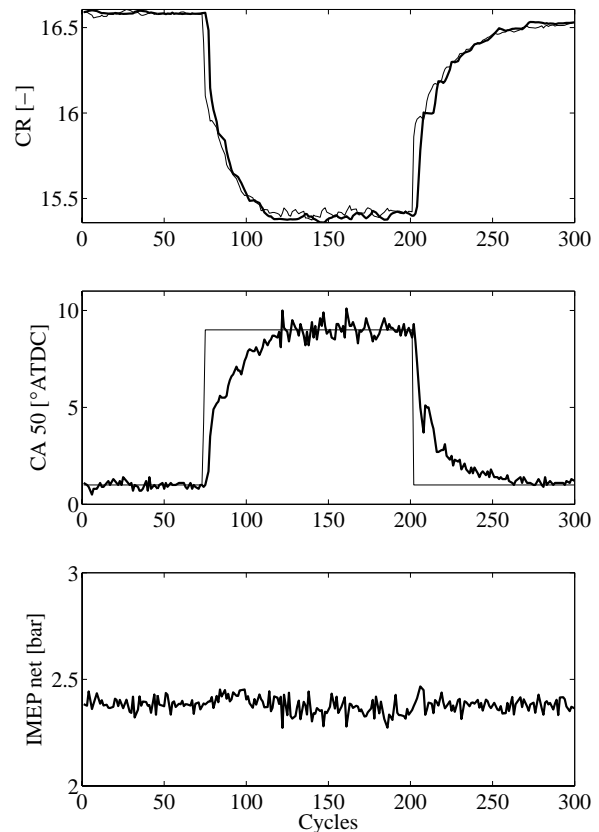

Figure 12 Step change in set point of CA50 from 1 to 9 to 1 CAD at 2000 rpm and 1.5 bar BMEP.

In the middle plot, CA50 and CA50 set point are plotted. In spite of constant load i.e. constant fuel amount, IMEP net is plotted in the lower part of the graph to show any influence the CLCC will have on load. The response from CA50 to CR set point is instant while the time constant for a positive step change in set point of CA50 from 1 to 9 CAD is 14 engine cycles, which at this speed is equivalent to 0.84s. The rate of CA50 change, (dCA50/dt), then equals 6.0 CAD/s. The negative step change has approximately the same time constant as the positive step change. COV IMEP is approximately 1.1% for the first 70 cycles and it rises to 1.7% over engine cycles 120 to 200 i.e. earlier combustion phasing results in a more stable CA50 but higher maximum

rate of pressure rise and peak cylinder pressure [18]. With more aggressive PID parameters the control will be unstable, especially when combustion is phased later ATDC, but more optimization of the PID parameters for the CLCC itself and, since the CR is a part of the CLCC, a faster CR control should decrease response time further.

Response to step change in load set point

A fast load response is needed in dynamic applications. In Figure 13 a negative and a positive step in load from 2.5 to 0.5 to 2.5 bar BMEP are performed with CA50 set point set to 7 CAD ATDC. In the lower plot IMEP net, thick line, and a normalized fuel amount, thin line, are plotted. At the same time as the fuel amount is decreased CA50 is retarded by three CAD due to increased lambda. The deviation of 3 CAD in CA50 at engine cycle 88 is on engine cycle 91 down to a CA50 of 5.9° ATDC. This means that the time constant is 3 engine cycles, which is equivalent to 180ms at 2000 rpm. The mean $dCA50/dt$ then equals 10.5 CAD/s.

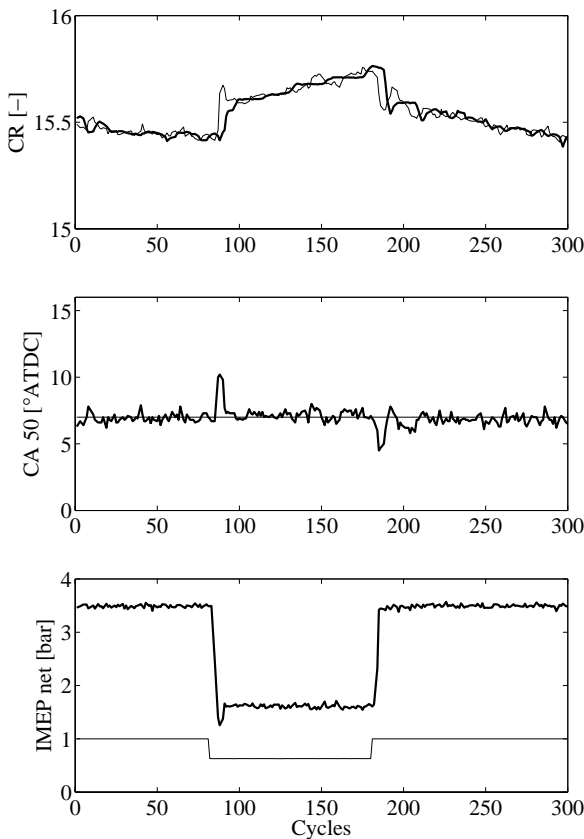

Figure 13 Load step change from 2.5 to 0.5 bar and back to 2.5 bar BMEP at 2000 rpm using CLCC.

The undershoot in mean IMEP net at engine cycle 87 to 91 is the effect of an already low load on two of the cylinders due to cylinder balancing. In this case, one cylinder deviates 1 bar from the other cylinders and almost misfires until the cylinder balancing increases the fuel amount due to excessively late combustion phasing. This behavior will be eliminated if the need

for lambda balancing is decreased. The $dCA50/dt$ is faster for the load change (10.5 CAD/s), than for the CA50 step change (6 CAD/s). This can be explained by an almost misfiring cylinder, which makes the deviation in mean CA50 large. This deviation is then minimized by both the CLCC and the cylinder balancing at the same time.

For the positive load step in Figure 13 at engine cycle 184 the mean CA50 goes from the set point of 7° ATDC to a maximum deviation of 2.5 CAD at engine cycle 185 and from there quickly to a mean CA50 of 6.2° ATDC at approximately engine cycle 190. This means it takes 5 engine cycles, i.e. 300ms at 2000 rpm to reduce the deviation by 63%.

Response to ramp change in inlet air temperature

The inlet air temperature in real applications could fluctuate. Therefore, it is interesting to be able to control CA50 with changes in temperature. Here the performance of CLCC is tested with a ramp in inlet air temperature from 205 to 140°C shown in Figure 14. No time constant for the CLCC is calculated. It is only shown how a fast change in inlet air temperature is handled. The temperature might seem high, but remember that all heat is taken from the heat recovery system, i.e. no electrical heat is needed.

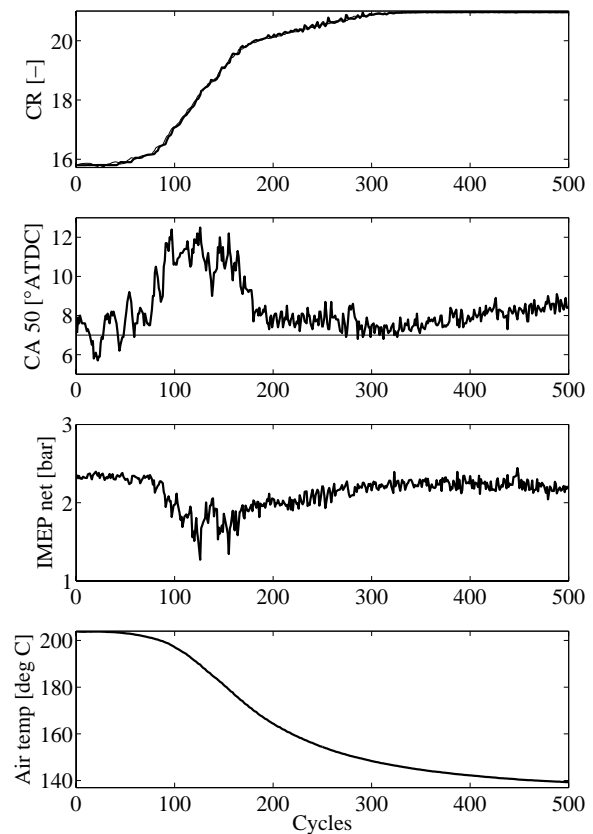

Figure 14 Negative ramp on inlet air temperature from 200 to 140°C at 2000 rpm and 1.5 bar BMEP using CLCC.

The highest rate of temperature change (dT/dt) is 9.6°C/s at approximately cycles 140-160, where the largest deviation in CA50 from the set point appears and where mean IMEP net has the largest drop of 1 bar due to excessively late CA50. COV for mean IMEP net goes from 1.5% for engine cycles 1 to 60, to 11% for engine cycles 61 to 250. The CR is adjusted from 15.8 to 21. Maximum CR is reached at engine cycle 300 i.e. the control variable is saturated. This results in a drift from set point in CA50. There is some ripple on the measured CA50 curve. It is due to difficulties with cylinder balancing when the throttle valve for cold inlet air is opened. The cold air is poorly mixed with the warm air and thus some cylinders have hotter contents than other cylinders and hence difficulties to keep CA50 [14].

Figure 15 plots the fuel offsets, set by the cylinder balancing, in percent from the set value, thin line and CA50, thick line. For cylinder 1 for example, which has the largest difference in fuel offset, the fuel offset starts at minus 14% and rises fast to the chosen maximum of plus 30%, when the inlet air temperature changes from 205 to 165°C . This phenomenon severely limits engine performance, but mixing of cold and warm air from the valves is only used for the ramps on inlet air temperature. For the other ramps, only hot air is used.

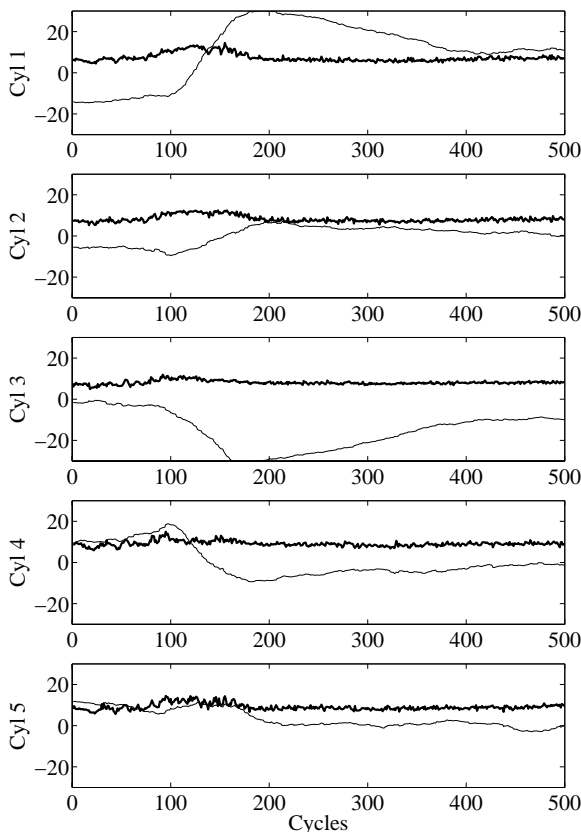

Figure 15 Cylinder individual fuel offset and CA50 for negative ramp on inlet air temperature from 200 to 140°C at 2000 rpm and 1.5 bar BMEP using CLCC.

The positive ramp on inlet air temperature is shown in Figure 16 and the temperature ramp goes from 140 to 205°C during the course of 500 engine cycles. It is obvious from the measured CA50 curve that it is easier to control a positive ramp than the negative ramp shown in Figure 14 i.e. there is no large ripple on the CA50 curve due to earlier combustion phasing, which is more stable. The maximum deviation from set point of CA50 is 7 CAD and there is very little impact on mean IMEP net. COV for mean IMEP net for the positive temperature ramp is 2.3%. The maximum dT/dt , is 10.7°C/s approximately at the CA for maximum divergence of CA50 from the set point. At engine-cycle 100 dT/dt is down to 4.4°C/s and the CLCC is continuously recovering from the early combustion phasing.

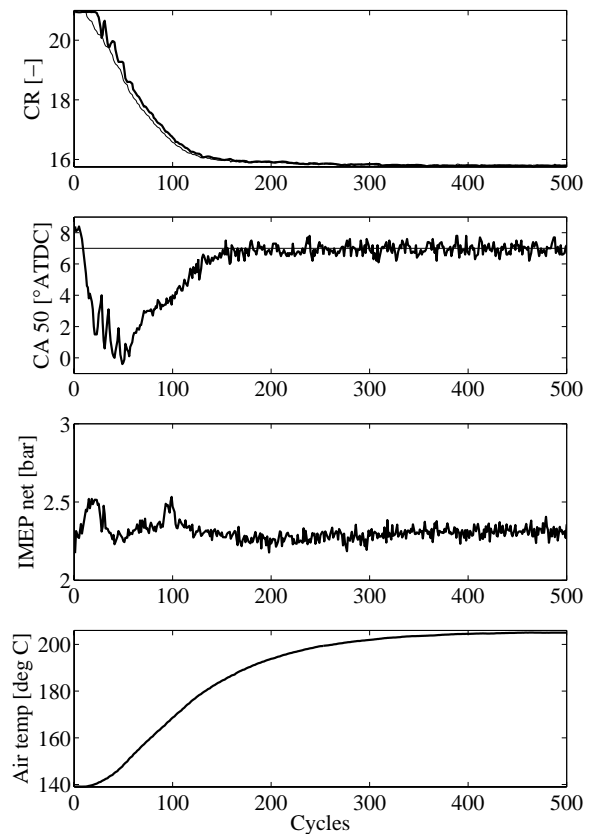

Figure 16 Positive ramp on inlet air temperature from 140 to 200°C at 2000 rpm and 1.5 bar BMEP using CLCC.

Comparing Figure 14 and Figure 16 to Figure 13 it is obvious that changes in inlet air temperature is much more challenging for the CLCC than are changes in load. If high rates of inlet air temperature changes are expected, these, and especially the negative temperature ramp, will dictate the required performance of the CLCC. These tests also show the possibility of fast temperature change; Figure 14 and Figure 16, where the rate of the temperature change actually are limited by the performance of the CLCC. Some part of the deviation in CA50 from the set point in Figure 14 could be eliminated if IMEP control were used, i.e. if combustion is late as in some cycles around engine cycle 140 IMEP decrease. This means

that the IMEP controller would increase the injected amount of fuel, which would result in advanced combustion phasing due to fuel richer mixture i.e. decreased lambda. The opposite is applicable for the positive inlet air temperature ramp in Figure 16, but not to the same extent.

Response to ramp change in speed

The performance of the CLCC using VCR is tested with speed ramps from approximately 1000 to 5000 rpm in Figure 17 and 5000 to 1000 rpm in Figure 18. The load is set by a constant injected fuel amount, which at 2000 rpm would result in a load of 2.5 bar BMEP for the positive ramp and 1.5 bar BMEP for the negative speed ramp. When manually raising the dynamometer speed, Figure 17, BMEP is kept fairly constant at 1 bar. Due to some minor difficulties with the data acquisition equipment, discussed under the cylinder pressure paragraph, where different sampling rates are used for different speeds, the PID parameters for the CLCC are decreased when running the speed transients.

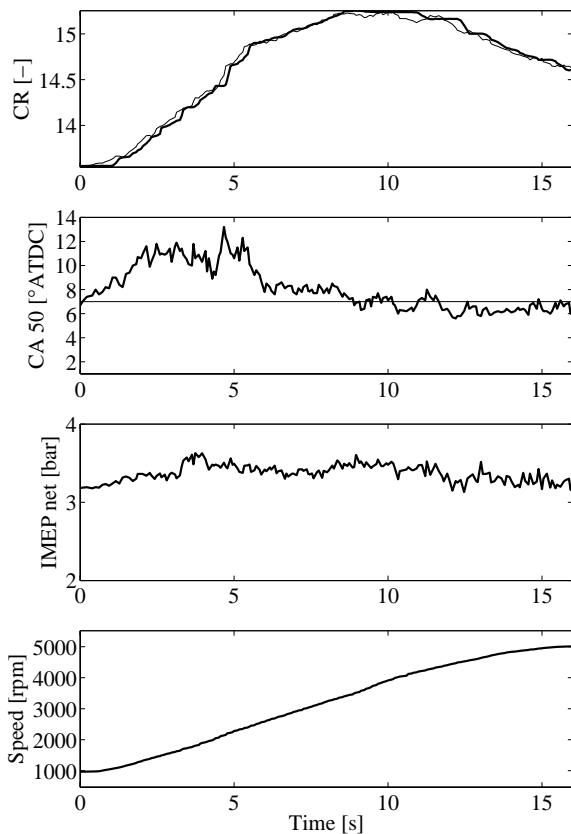

Figure 17 Positive ramp on engine speed, using CLCC, from 1000 to 5000 rpm at a load equivalent to 2.5 bar BMEP at a constant speed of 2000 rpm.

The total time for the positive speed ramp is 16s, and is completed in 412 engine cycles. COV for mean IMEP net is 3.2%. During the speed ramp, CA50 is retarded by a maximum of 6 CAD at 4.6s from start, when the rate of speed change (dN/dt), of 56700 rpm^2 or 15.7 rps^2 , is at its maximum. This is due to decreased time to initiate combustion. It is then

compensated for by increasing CR by the CLCC. The upper plot shows the applied CR, thick line, and the set point for CR, thin line, which starts at 13.5 and ends at 14.6. There is a maximum CR of 15.2 at approximately 10s. From there, the CR decreases due to increased wall temperature, which is the result of decreased heat losses at higher engine speeds. The inlet air temperature decreases by approximately 4°C over the transient. This does not seem to disturb the performance though.

The negative speed ramp, Figure 18, CR starts at 15.6 and ends at 14.7. The earliest CA50 is 1.9° ATDC at 8.1s after start, while the maximum dN/dt 75500 rpm^2 or 21.0 rps^2 is at 5.7s. COV for mean IMEP net for the first 8s is 4.0%, compared to 1.9% after 8s.

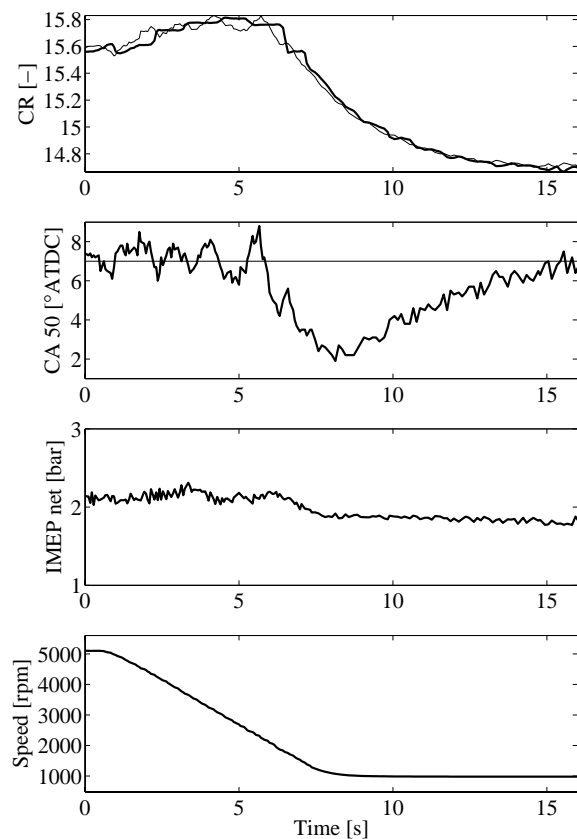

Figure 18 Negative ramp on engine speed, using CLCC, from 5000 to 1000 rpm at a load equivalent to 1.5 bar BMEP at a constant speed of 2000 rpm.

The reasons for the advanced combustion phasing are more time to initiate combustion and higher inlet air temperature due to inertia in the heat recovery system. At high speeds, there are higher amounts of heat energy transferred in the heat exchanger. At transients, the heat transfer is approximately constant while the air mass is changed. For lower engine speed the air mass is reduced, which results in higher temperature of the inlet air, in Figure 18 by 10°C , which helps advance the combustion and explains the difference between time for maximum dN/dt and CA50 deviation. With a more complex control strategy for the speed ramps, the deviation in CA50 could be

decreased. With increasing injected fuel amount during the positive speed ramp, CA50 would be advanced, while decreasing the fuel amount for the negative speed ramp would result in retarded combustion phasing. This strategy is also more like a transient in a passenger car application.

SUMMARY

It might be interesting to compare the time constants for the different transients made here with other similar tests. Since transients for HCCI is rather limited publicized, the comparison is rather coarse. Comparing data is from Olsson et al. [11] who ran a 12L turbocharged Scania in HCCI with dual fuel and an older version of CLCC at 1500 rpm. For both SVC and the Scania are the time constant given in engine cycles and if available in seconds. The time constant (τ), in Table 2 is given as the time to reach 63% of the set point. Please remember that the steps and ramps are not the same for the different engines. Instead, are the rates of change calculated or estimated.

Table 2 Time constants

Engine	SVC HCCI	Scania HCCI
Response to step change of 1 unit in CR	$\tau = 3$ cycles or (180ms) $dCR/dt = 3.5$ CR units/s	
Response to step change of 8 CAD in CA50	$\tau = 14$ cycles or (0.84s) $dCA50/dt = 6.0$ CAD/s	(8-3=5 CAD) 5 cycles (0.4s) $dCA50/dt = 7.9$ CAD/s
Response to step change of 2 bar in load \Leftrightarrow (3 CAD in CA50)	$\tau = 3$ cycles or (180ms) $dCA50/dt = 10.5$ CAD/s	
Cylinder balancing (to reach steady state)	28 cycles or 1.7s	
Temperature ramp 140-200°C	Max $dT/dt = 10.7^\circ\text{C/s}$	
Temperature ramp 200-140°C	Max $dT/dt = -9.6^\circ\text{C/s}$	
Speed ramp 1000-5000 rpm (Speed = N)	Max $dN/dt = 15.7 \text{ rps}^2$	(1000-2000 rpm) Max $dN/dt = 1.3 \text{ rps}^2$
Speed ramp 5000-1000 rpm	Max $dN/dt = -21.0 \text{ rps}^2$	(2000-1000 rpm) Max $dN/dt = -1.3 \text{ rps}^2$

The time for the speed ramp is only a measure of how much CA50 deviates from the set point, since the rate of speed change is dependent of the inertia of the entire system. Fraidl et al. [20] ran a lean burn GDI HCCI using closed-loop control, which was, tested 1500 to 3000 rpm with a mean $dN/dCycles$ of 15.8 compared to 20.1 rpm/cycle for the SVC engine over the same speed range.

CONCLUSION

- Closed-loop combustion control using accurate and fast variable compression ratio is run with acceptable performance. Time constant of three engine cycles is achieved for the compression ratio control or 180ms at 2000 rpm with a dCR/dt of 3.5 CR units/s. The closed-loop combustion control system of cascade coupled compression ratio and CA50 controllers has a time constant of 14 engine cycles or 0.84s at 2000 rpm with a $dCA50/dt$ of 6.0 CAD/s.
- Load steps between 2.5 to 0.5 bar and back to 2.5 bar BMEP are run. The negative step change results in a slight undershoot in IMEP net due to cylinder balancing while the easier positive step change is handled well. The response of the step change in load actually shows a $dCA50/dt$ of 10.5 CAD/s due to a combined effort of cylinder balancing and closed-loop combustion control.
- Speed ramps from 1000 to 5000 and 5000 to 1000 rpm are run. The negative speed ramp is run with as fast speed change as the dynamometer allows and has a maximum dN/dt of -21.0 rps^2 . The positive speed ramp is more demanding and has a maximum dN/dt of 15.7 rps^2 for a delivered load of 1 bar BMEP. The given rates of speed change are an indication of how fast speed ramps the system handles with constant fuel amount.
- Temperature ramps are run both positive and negative. Handling of the positive ramp is satisfactory with an earliest CA50 at TDC, while the negative ramp is more demanding for the controller since the combustion goes late, 13 CAD ATDC, and late combustion is much harder to control.
- Cylinder balancing with variable lambda is shown to work, with the disadvantage of large deviation in IMEP net when no CA50 offset is used. The time from no cylinder balancing to a steady state value is 1.7s or 28 cycles at 2000 rpm.

REFERENCES

1. S: Onishi, S. Hong Jo, K. Shoda, P Do Jo, S. Kato, "Active Thermo-Atmosphere Combustion (ATAC) – A New Combustion Process for Internal Combustion Engines", SAE790501
2. Y. Ishibashi, M. Asai, "Improving the Exhaust Emissions of Two-Stroke Engines by Applying the Activated Radical Combustion", SAE960742
3. P. Najt, D.E. Foster, "Compression-Ignited Homogeneous Charge Combustion", SAE830264
4. R.H. Thring, "Homogeneous-Charge Compression-Ignition (HCCI) Engines", SAE892068
5. M. Stockinger, H. Schäpertöns, P. Kuhlmann, "Versuche an einem gemischansaugenden mit Selbstzündung", MTZ 53 (1992).
6. M. Christensen, P. Einewall, B. Johansson, "Homogeneous Charge Compression Ignition (HCCI) Using Isooctane, Ethanol and Natural Gas – A Comparison to Spark Ignition Operation", SAE972874
7. M. Christensen, B. Johansson, P. Amnéus, F. Mauss, "Supercharged Homogeneous Charge Compression Ignition", SAE 980787
8. M. Christensen, B. Johansson: "Influence of Mixture Quality on Homogeneous Charge Compression Ignition", SAE982454
9. M. Christensen, B. Johansson, "Homogeneous Charge Compression Ignition with Water Injection", SAE1999-01-0182
10. G. Haraldsson, J. Hyvönen, P. Tunestål, B. Johansson, "HCCI Combustion Phasing in a Multi Cylinder Engine Using Variable Compression Ratio", SAE 2002-01-2858.
11. J-O. Olsson, P. Tunestål, B. Johansson, "Closed-Loop Control of an HCCI Engine", SAE 2001-01-1031
12. M. Christensen, A. Hultqvist, B. Johansson, "Demonstrating the Multi Fuel Capability for a Homogeneous Charge Compression ignition Engine with Variable Compression Ratio", SAE 1999-01-3679
13. J-O. Olsson, P. Tunestål, B. Johansson, S. Fiveland, R. Agama, M. Willi, D. Assanis, "Compression Ratio Influence on Maximum Load of a Natural Gas Fueled HCCI Engine" SAE 2002-01-0111
14. J. Hyvönen, G. Haraldsson, B. Johansson, "Operating range in a Multi Cylinder engine using Variable Compression Ratio" JSAE 20030178/SAE 2003-01-1829
15. J-O. Olsson, P. Tunestål, G. Haraldsson, B. Johansson, "A Turbo Charged Dual Fuel HCCI Engine", SAE 2001-01-1896
16. H. Drangel, L. Bergsten, "The new Saab SVC Engine - An Interaction of Variable Compression Ratio, High Pressure Supercharging and Downsizing for Considerably Reduced Fuel Consumption", 9. Achener Kolloquium Fahrzeug- und Motorentechnik 2000
17. J. G. Ziegler, N. B. Nichols, "Optimum settings for automatic controllers" ASME 1942
18. D. Flowers, S. Aceves, J. M. Frias, J. R. Smith, M. Au, J. Girard, R. Dibble, "Operation of a Four-Cylinder 1.9L Propane Fueled Homogeneous Charge Compression Ignition Engine: Basic Operating Characteristics and Cylinder-to-Cylinder Effects", SAE 2001-01-1895
19. M. Christensen, "HCCI Combustion Engine Operation and Emission Characteristics", Doctoral Thesis LUND 2002
20. G. K. Fraidl, W. F. Piock, A. Fürhapter, E. M. Unger, T. Kammerdiener, "Homogene Selbstzündung – die Zukunft der Benzin-Direkteinspritzung?", MTZ 10/2002

CONTACT

Göran Haraldsson, MSc M. E.
E-mail: goran.haraldsson@vok.lth.se

Jari Hyvönen, MSc M. E.
E-mail: jari.hyvonen@vok.lth.se

Per Tunestål, Assistant Professor
E-mail: per.tunestal@vok.lth.se

Bengt Johansson, Professor.
E-mail: bengt.johansson@vok.lth.se

Department of Heat and Power Engineering, Division of Combustion Engines, Lund Institute of Technology, P.O. Box 118, SE-221 00 Lund, Sweden.

DEFINITIONS, ACRONYMS, ABBREVIATIONS

ATDC: After Top Dead Centre

A/D: Analog / Digital

BMEP: Brake Mean Effective Pressure

BTDC: Before Top Dead Centre

CAD: Crank Angle Degree

CA50: Crank Angle for 50% burned

CI: Compression Ignition

CLCC: Closed-Loop Combustion Control

COV: Coefficient Of Variation

CR: Compression Ratio

dCA50/dt: Rate of timing change

dCR/dt: Rate of CR change

dN/dt: Rate of Speed raise

dT/dt: Rate of Temperature raise

EGR: Exhaust Gas Recirculation

GUI: Graphical User Interface

HCCI: Homogeneous Charge Compression Ignition

IMEP: Indicated Mean Effective Pressure

ISA: Industry Standard Architecture bus

PCI: Peripheral Component Interconnect local bus

PIC: Peripheral Interface Controller

PID: Proportional Integral Derivative

PWM: Pulse Width Modulation

RAM: Random Access Memory

RON: Research Octane Number

SI: Spark Ignition

SVC: Saab Variable Compression

TDC: Top Dead Center

TTL: Transistor-Transistor Logic

VCR: Variable Compression Ratio