



# LUND UNIVERSITY

## Closed-Loop Combustion Control of a Multi Cylinder HCCI Engine using Variable Compression Ratio and Fast Thermal Management

Haraldsson, Göran

2005

[Link to publication](#)

*Citation for published version (APA):*

Haraldsson, G. (2005). *Closed-Loop Combustion Control of a Multi Cylinder HCCI Engine using Variable Compression Ratio and Fast Thermal Management*. [Doctoral Thesis (compilation), Combustion Engines]. Division of Combustion Engines, Lund Institute of Technology.

*Total number of authors:*

1

### General rights

Unless other specific re-use rights are stated the following general rights apply:

Copyright and moral rights for the publications made accessible in the public portal are retained by the authors and/or other copyright owners and it is a condition of accessing publications that users recognise and abide by the legal requirements associated with these rights.

- Users may download and print one copy of any publication from the public portal for the purpose of private study or research.
- You may not further distribute the material or use it for any profit-making activity or commercial gain
- You may freely distribute the URL identifying the publication in the public portal

Read more about Creative commons licenses: <https://creativecommons.org/licenses/>

### Take down policy

If you believe that this document breaches copyright please contact us providing details, and we will remove access to the work immediately and investigate your claim.

LUND UNIVERSITY

PO Box 117  
221 00 Lund  
+46 46-222 00 00

# System Identification and LQG Control of Variable-Compression HCCI Engine Dynamics

Roland Pfeiffer, Göran Haraldsson, Jan-Ola Olsson, Per Tunestål, Rolf Johansson, Bengt Johansson  
Lund Institute of Technology, Sweden

**Abstract—** The Homogenous Charge Compression Ignition (HCCI) combustion engine has potential to replace the spark ignition and compression ignition engines of today. One of the main problems in making the engine commercially attractive is the lack of direct means of controlling the ignition phasing. In this paper, we investigate the potential of inlet air temperature as a means to ignition actuation. This article describes a method for system identification of the HCCI process, and development of an effective LQG regulator for the combustion process, Matlab and Simulink being used in computations and simulations.

## I. INTRODUCTION

COMBUSTION engines are very important to every one of us. They are used to power vehicles as well as electrical power generators, mobile pumps and so on. However current combustion engines all have some drawback. Spark Ignition (SI) engines have low emissions but high fuel consumption. Compression Ignition (CI) engines have low fuel consumption but high emissions. An attempt to obtain the best behavior from both SI and CI engines is the Homogeneous Charge Compression Ignition (HCCI) engine. It has the low fuel consumption of the CI engine combined with the low emissions of the SI engine [1].

The HCCI engine does have its drawbacks however. Due to its operation there is no direct way of controlling the ignition phasing. This means that it is very hard to control the engine. As a step towards building a better controller than is available today, this paper aims at identifying the process and subsequently developing an effective controller.

For a given amount of fuel; the torque should be maximized. This is achieved by controlling the ignition phasing which is affected by Compression Ratio (CR), Inlet Air Temperature (IAT), engine speed and injected fuel amount. The HCCI process can thus be considered to be a multi-input, single-output system. The model can be expanded with more inputs as well as outputs. This work however targets the signals mentioned above.

The ignition phasing is characterized by the crank angle

degree where 50% of the fuel has been consumed by combustion (CA50) [4]. The crank angle degree is measured from Top Dead Center (TDC), which is located at 0°. TDC is defined as the crank angle when the piston is at its top position and the volume of the combustion chamber is at its minimum.

In an HCCI engine the fuel is injected outside the cylinder into the inlet manifold, alternatively if direct injection is used, the fuel is injected early to let the fuel and air form a homogeneous mixture. This is the same procedure as in an ordinary SI engine. This prevents the formation of NOX and soot. The air/fuel mixture then auto ignites from the temperature rise that occurs as a result of the piston compressing the mixture.

### A. The Engine

The engine (see Table 1) used for the experiments performed as part of this work, is built by SAAB and originally built as an SI engine with variable CR. The engine has subsequently been converted to HCCI operation by increasing CR, and equipped with a heat exchange system that allows the heat in the exhaust gas to be used to heat the inlet air. Valves are then used to select how much of the inlet air should be taken from the heat-exchanging device or from unheated air. This modification has been performed at the Lund Institute of Technology.

TABLE I  
ENGINE SPECIFICATIONS

Displacement	1598 cm <sup>3</sup> (320 cm <sup>3</sup> /cyl)
Nr. of cylinders	5
Compression ratio	Adjustable 9 - 30:1
Bore x Stroke	68mm x 88mm

It is possible to use cylinder individual IAT to balance the ignition phasing by having one throttle for each cylinder for cold air and one common for hot air [7]. In the tests the engine is naturally aspirated, i.e. the engine is not supercharged in any way. The fuel used is 91-octane gasoline.

### B. Implementation

The LQG controller has been implemented in the PID based engine control program used in previous work on the engine [8] and [9].

### C. Measuring IAT

The first sets of experiments revealed that the thermo couple measuring IAT was too slow and hence no measurement of IAT was performed. Instead, the throttle opening for cold air flow was used.

## II. EXPERIMENTS

### A. Initial Experiments

The initial experiments were done by feeding step changes to the process inputs and observing the output. The magnitudes of the step changes were increased until nonlinear behavior was observed, or until the input or output were close to going outside of normal operating range. The step response experiments were performed on each of the input signals, one at a time.

### B. Main Experiments

Test series of 2000 engine cycles provide an adequate amount of data from which the identification can be made. The operating points referred to in this section are listed in section VI.

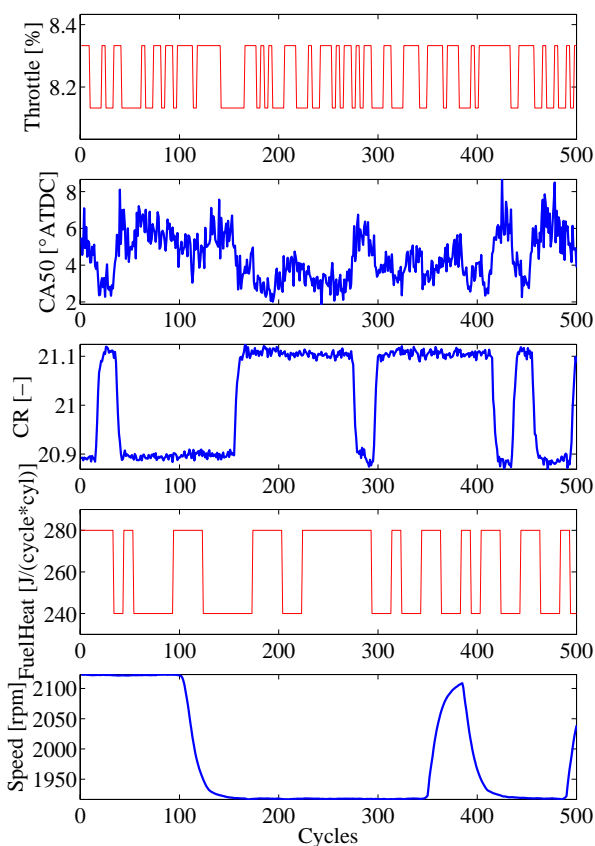

Fig. 1 PRBS signals added to the input signals.

To create the disturbances needed to perform identification of the process, Pseudo Random Binary Sequences (PRBS) [2] were used. The initial experiments indicates that the process could be excited using a PRBS amplitude of  $\pm 40$

Joule/cycle on the fuel heat (this is the heat content of the injected fuel),  $\pm 0.2$  units on compression ratio,  $\pm 300$  rpm on engine speed and  $\pm 0.2\%$  units on the valve controlling the inlet air temperature.

The shortest periods that the values of the PRBS signals were held were chosen to be 20, 4, 10 and 35 engine cycles for CR, Throttle, Fuel Heat and engine speed, respectively. The reason for choosing longer periods for the CR and speed disturbances are that these controls have mechanical limitations that has to be considered. The minimum period for the Fuel Heat signal should have been shorter, but a programming error caused the period time to be ten cycles.

When performing the tests, excitation was applied to all four input signals concurrently. This meant that if all disturbances worked in the same direction the process would be pushed out of the linear range even though the individual input signals were in range. This was found to be a problem when performing the first round of experiments. To minimize the risk of such nonlinear distortion, the concurrent excitation levels were chosen to be approximately 50% of the values stated above.

Plots of the input and output signals for one cylinder obtained from the experiment indexed 7 can be viewed in Fig. 1. The thin lines of throttle and fuel heat corresponds to set values while the thicker lines of CA50, CR and Speed corresponds to measured values. Only values from engine cycles up to 500 are included in the plots.

## III. SYSTEM IDENTIFICATION

To be able to perform system identification it must be possible to distinguish the disturbances in the output signal caused by the excitation from the disturbances caused by inherent noise. One way to measure the amount of excitation of the output signal is to calculate the signal-to-noise ratio. This can be estimated using Eq. (1). In this equation  $std(CA50)$  denotes the standard deviation of the output signal.

$$S/N = \frac{std(CA50)_{Excited}}{std(CA50)_{Unexcited}} \quad (1)$$

It was found that the signal to noise ratio was approximately 2.6. This should be adequate to succeed when performing identification.

### A. Method

The Matlab<sup>®</sup> function *n4sid* was used to perform system identification on the data collected from the experiments. This function makes use of a subspace algorithm described in [3].

### B. Model Validation

Every identified model was cross-validated using a different set of measurements from the one used for identification. The correlation between simulated and

measured output was used as criterion

Correlation between simulated and measured output is a good measure of how well the model manages to mimic the behavior of the real engine, the correlation being a value that will be at most 1.

### C. Sampling Rate

The time base for the combustion process was not seconds, but engine cycles. The combustion event takes place every second revolution of the crankshaft, i.e., every engine cycle. The setting of the fuel injection, and the output, i.e. CA50, are both discrete signals, with one value for every engine cycle. Whereas throttle, CR and engine speed are continuous signals, they only affect the process once every cycle. Therefore, it makes sense to base the identification, and subsequently the controller, on the time base of one engine cycle. Thus, the sampling rate is, by definition, 1 sample per cycle. This approach avoids some of the problems encountered in earlier approaches to characterize the dynamic behavior of the reciprocating combustion engine [5] and [6].

### D. Choice of Model Complexity

It is often the case that a large order model will perform better than a small order model. However, this does not mean that the larger order model is necessarily the better choice. In general it is better to choose a smaller order model as long as it performs almost as well as the larger order models. The smaller order model will have fewer parameters that have to be determined. The parameters can thus be determined more accurately. The order of the model was decided by comparing the accuracy of models of several orders. For each model order between 1 and 15 a model was constructed using data from each of the measurements. The correlation between measured and simulated process output was then calculated for each of the different operating points. The resulting model was chosen to be of second order.

### E. One Model or Several?

It is a well-known fact that the engine changes behavior from one operating point to another. The question to be answered is whether the process varies enough to demand several models to simulate its behavior. One (second order) model for each of the tested operating points was created. The correlation between the models and validation data from that same operating point was then calculated. A model created using data from all the tested operating points was also produced; this model will henceforth be referred to as the merged model. The correlation between the merged model and validation data from each operating point was then calculated and compared to the value obtained using the operating point individual models.

As can be expected the operating point individual models

nearly always produces a better result than the merged model. However, the merged model is at all operating points performing almost as well as the individual models.

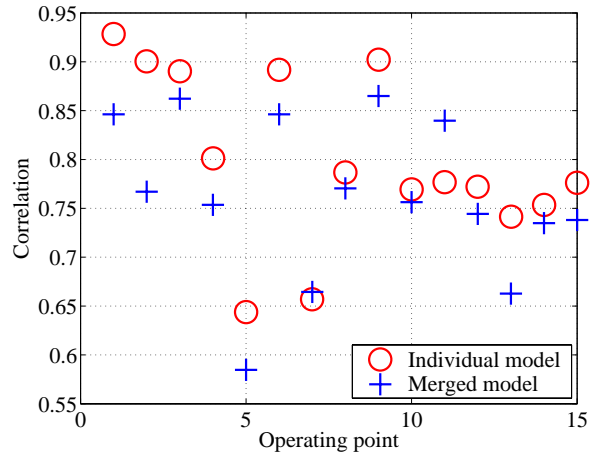

Fig. 2 Correlation between measured and simulated output for operating point individual models compared to a merged model.

A graph showing the result is found in Fig. 2. The correlation values even for the merged model are never below 0.58. A correlation of 0.58 is a good value. It is thus decided that one model should be sufficient to describe the process at all the examined operating points. This is discussed in section IV.E. The model is a second-order discrete state space model, which is extended to a fifth-order due to time delay on the throttle response. The model has the following structure:

$$\begin{aligned} x_{k+1} &= Ax_k + Bu_k + w_k \\ y_k &= Cx_k + Du_k + v_k \end{aligned} \quad (2)$$

In Eq. (2),  $w_k$  and  $v_k$  are white process and measurement noise respectively.  $y_k$  is CA50 and  $u_k$  is a vector consisting of throttle, CR, fuel heat and engine speed. It was found that a process noise variance of  $2 \cdot 10^{-9}$  and a measurement noise variance of 0.125 gave noise characteristics similar to that of the real process

The matrices in (2) are as follows:

$$A = \begin{pmatrix} 0.79732 & 0.50455 & 0 & 0 & 0.083843 \\ -0.93326 & 0.61003 & 0 & 0 & -0.035222 \\ 0 & 0 & 0 & 0 & 0 \\ 0 & 0 & 1 & 0 & 0 \\ 0 & 0 & 0 & 1 & 0 \end{pmatrix}$$

$$B = \begin{pmatrix} 0 & -0.0031596 & -2.4059 \cdot 10^{-5} & 2.1599 \cdot 10^{-5} \\ 0 & -0.0059634 & 6.4163 \cdot 10^{-8} & -1.35 \cdot 10^{-5} \\ 1 & 0 & 0 & 0 \\ 0 & 0 & 0 & 0 \\ 0 & 0 & 0 & 0 \end{pmatrix}$$

$$C = (358.14 \quad -76.753 \quad 0 \quad 0 \quad 0)$$

$$D = (0 \quad 0 \quad -0.00026456 \quad -0.008621)$$

#### IV. CREATING A CONTROLLER

The controller uses only the cold-throttle as an actuator to control the ignition phasing [7]. The variable compression ratio was used to achieve optimal operation for the engine. The engine load and speed were results of user demands.

##### A. Method

Matlab functions *kalman*, *dlqr* and *lqgreg* were used to create a Linear Quadratic Gaussian (LQG) controller. This controller structure was chosen since it is capable of handling Multi-Input, Multi-Output (MIMO) systems in a systematic way.

As input signal to the controller the difference between the reference signal for CA50 and the measured CA50 value was used. Since the model can not be expected capture the exact behavior of the real engine, it was necessary to make use of an integrator to remove steady state errors.

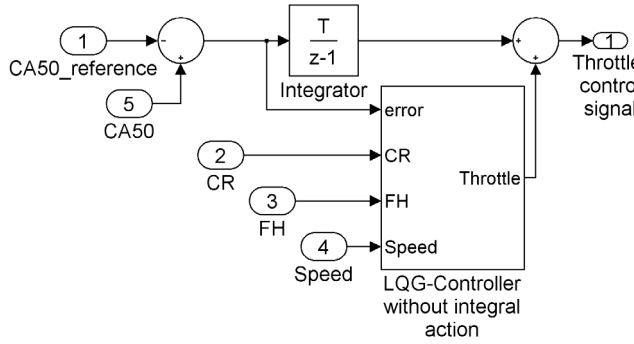

Fig. 3 Illustration of how the integrator is added to the controller

In order to add integral action to the controller; an integrating state is first added to the process model. The extended model is then used to create a feedback matrix and a Kalman observer. These are then merged to form controller on the form (4).

As can be seen in Fig. 3, the integrator is placed in parallel with the LQG-controller. This is only an illustration of how the final controller looks internally; the integrator is merged with the LQG-controller to a state space representation.

##### B. Tuning

LQG controllers aim at minimizing the loss function

$$J(u) = \sum_{k=0}^{\infty} x_k^T Q x_k + u_k^T R u_k + 2x_k^T N u_k, \quad (3)$$

where the matrices Q, R and N are design parameters used to put individual weights on controller states and control signals.

The controller structure is:

$$\begin{aligned} z_{k+1} &= A_c z_k + B_c e_k \\ u_k &= C_c z_k + D_c e_k \end{aligned} \quad (4)$$

where  $e_k$  is the difference between  $CA50_{ref}$  and CA50 at cycle k and  $u_k$  is a scalar containing the throttle command.

The z-vector contains the controller states. After adding the integrator the matrices have the following values:

$$A_c = \begin{pmatrix} 0.25492 & 0.62079 & 0 & 0 & 0.083843 & 0 \\ 0.22269 & 0.5423 & 0 & 0 & -0.035222 & 0 \\ -2.0931 & -5.0974 & -0.37489 & -0.22558 & -0.12414 & 0 \\ -2.177910^{14} & 4.667510^{15} & 1 & 0 & 0 & 0 \\ -2.764310^{15} & 5.924110^{16} & 0 & 1 & 0 & 0 \\ 0 & 0 & 0 & 0 & 0 & 1 \end{pmatrix}$$

$$B_c = \begin{pmatrix} -0.0031596 & -2.3659 \cdot 10^{-5} & 3.4656 \cdot 10^{-5} & 0.0015145 \\ -0.0059634 & -1.6928 \cdot 10^{-7} & -2.1107 \cdot 10^{-5} & -0.00088237 \\ 0 & -5.2598 \cdot 10^{-7} & -1.7139 \cdot 10^{-5} & -0.0019881 \\ 0 & 1.6088 \cdot 10^{-20} & 5.2426 \cdot 10^{-19} & 6.0811 \cdot 10^{-17} \\ 0 & 2.042 \cdot 10^{-21} & 6.6541 \cdot 10^{-20} & 7.7185 \cdot 10^{-18} \\ 0 & 0 & 0 & 0 & 1 \end{pmatrix}$$

$$C_c = (-2.0931 \quad -5.0974 \quad -0.37489 \quad -0.22558 \quad -0.12414 \quad 1.0264 \cdot 10^{-3})$$

$$D_c = (0 \quad 0 \quad -0.00026456 \quad -0.008621)$$

##### C. Bode diagrams

The Bode diagrams in this section are created using the identified engine model and the developed controller.

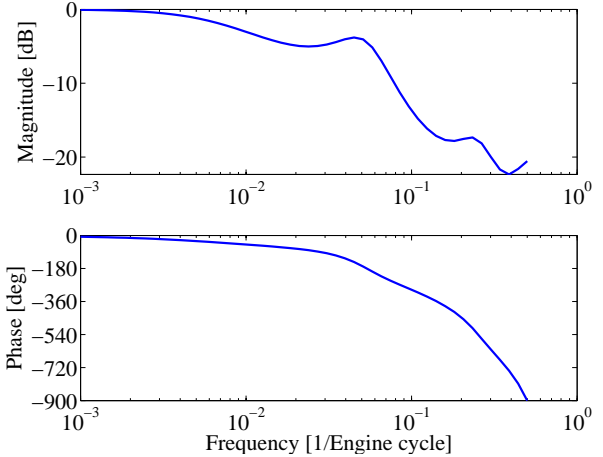

Fig. 4 Bode plot from reference to output for the closed-loop engine controller structure.

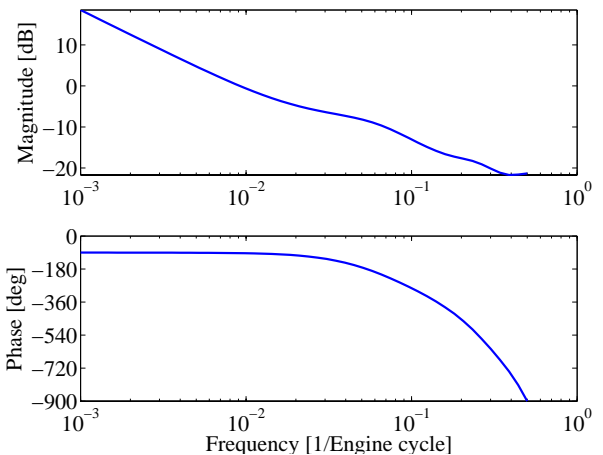

Fig. 5 Bode plot from reference to output for the open-loop engine controller system.

The Bode diagram of the closed loop system (Fig. 4) shows that the controller achieves a 0 dB amplification for low frequencies, this is desirable since it indicates that the output will reach the desired level.

In Fig. 5, the Bode diagram for the open loop controller-engine system is displayed. The plot shows that the open loop system is stable and has a phase margin of  $86^\circ$  and gain margin of 8.5 dB.

#### D. Anti windup

To avoid windup of the controller states, a tracking mode is introduced. This is added to the control law in accordance with the following equations

$$z_{k+1} = A_c z_k + B_c y_k + K(u_k - C_c z_k - D_c y_k)$$

$$u_k = \text{sat}(C_c z_k + D_c y_k)$$

Here *sat* represents the saturation level of the actuator. The matrix *K* can be chosen by simple pole placement such that the control law becomes stable. This technique is described in [10].

#### E. Results

Initial experiments showed that the controller was too sensitive when the reference value of the ignition phasing was later than 7 degrees after TDC. The reason for this is that the engine is a non-linear process. The engine model on which the controller is based has been derived using mostly data collected at early ignition phasings. Thus the controller was optimized for this case.

This indicates that it is necessary to identify the process at operating points with late ignition phasing as well. This has not been done. Instead, a less sensitive controller has been designed using the same engine model. The two controllers are run simultaneously for each cylinder, one LQG-optimized and one less sensitive, where the outputs are weighted together as a function of set point for CA50.

Testing the controller described above on the engine produces the result illustrated in Fig. 7. The performance of the LQG-controller should be compared to that of the PID-controller (Fig. 6). As can be seen the LQG-controller is faster and does a better job at suppressing the disturbance induced by the CR.

Both of the controllers struggle when the engine speed drops to below 1500 rpm. The reason for this is that the combustion process changes significantly at this rpm due to Low Temperature Reactions (LTR) [9].

Fig. 6 and Fig. 7 display measured BMEP, the reason for the strange looking curves being that the inertia of the engine has not been compensated for in the measurements or in the control.

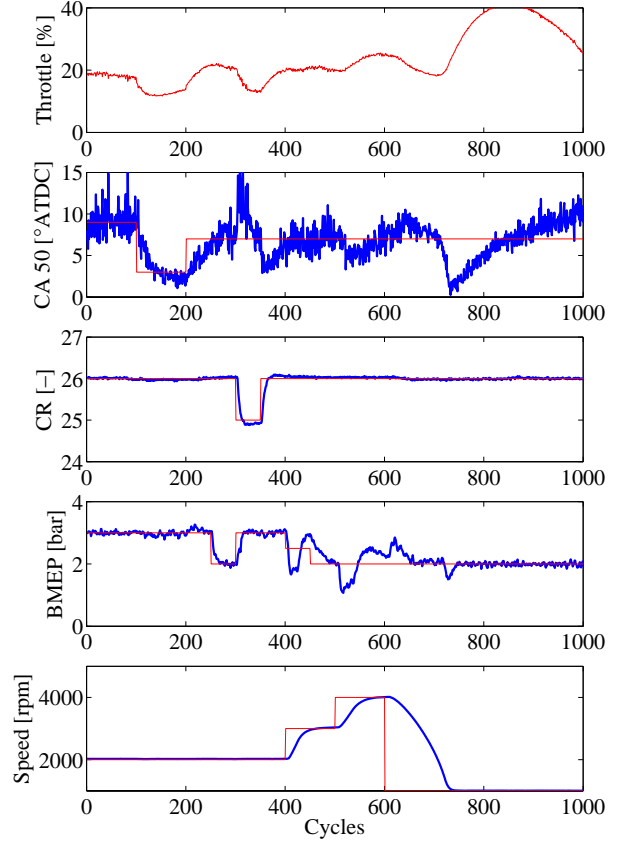

Fig. 6 Performance of PID regulator

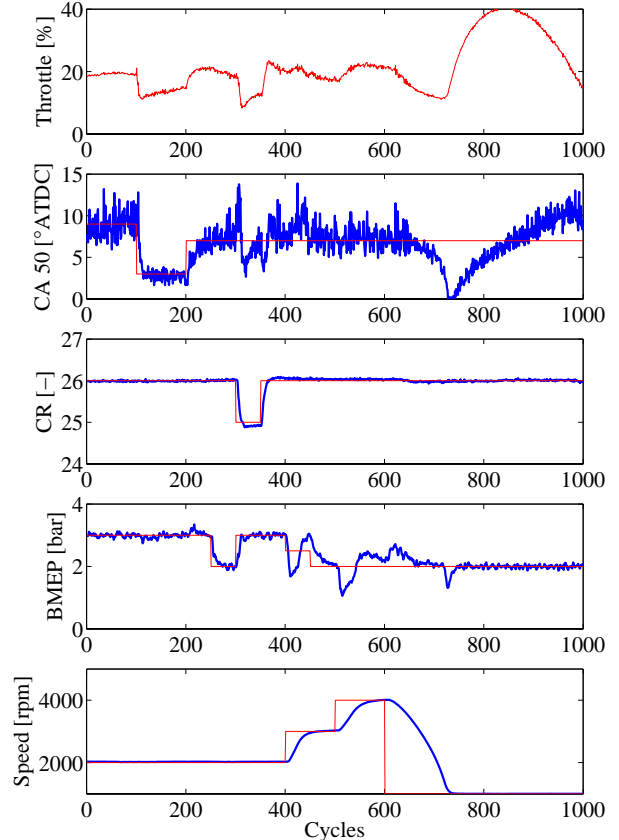

Fig. 7 Performance of LQG regulator

## V. DISCUSSION

Since LQG-controllers are capable of handling MIMO systems, it should be possible to develop a controller capable of using CR as well as IAT to control ignition phasing. It should also be possible to control the torque of the engine, which is the driver's main concern.

From Fig. 6 and Fig. 7 it is obvious that LTR are a major problem that needs to be addressed. When operating the engine at certain CR's and IAT's the LTR lead to larger need for cold IAT and when outside of that region the cold air is not needed. The difference is significant and puts extreme demands on the combustion phasing controller.

## VI. OPERATING POINTS

TABLE 2 lists the targeted operating points. At least two experiments have been performed at each operating point.

TABLE 2  
OPERATING POINTS

Id	Fuel Load (J/cycle)	CR	IAT valve (%)	Mean temp. (°C)	Speed (rpm)	CA50 mean
1	230±10	26±0.1	3.1±0.1	104	1000 ±30	1.1
2	310±10	24±0.1	4.1±0.1	97	1000 ±30	2.4
3	250±10	21±0.1	4.6±0.1	172	1500 ±50	2.3
4	300±10	21±0.1	4.4±0.1	172	1500 ±50	2.9
5	390±10	21±0.1	7.7±0.1	144	1500 ±50	10.8
6	200±20	21±0.1	2.9±0.1	197	2000 ±100	2.1
7	260±20	21±0.1	7.4±0.1	186	2000 ±100	4.3
8	310±20	21±0.1	8.7±0.1	175	2000 ±100	6.5
9	190±20	20±0.1	8.5±0.1	219	3000 ±100	2.5
10	260±20	20±0.1	13.5±0.1	204	3000 ±100	5.9
11	310±10	20±0.1	13.5±0.1	198	3000 ±100	4.1
12	220±10	20±0.1	22.4±0.1	204	4000 ±200	7.0
13	270±10	20±0.1	23.4±0.1	192	4000 ±100	8.4
14	200±20	18±0.1	16.6±0.1	231	4500 ±200	2.4
15	250±20	18±0.1	22.1±0.1	223	4500 ±200	3.3

## VII. CONCLUSIONS

A procedure for system identification on HCCI engines has been developed. The method is simple and produces good results.

It has been found that a low-order model is sufficient to describe the process dynamics. The process however is highly nonlinear in that it is much more sensitive to control

action at a late timing than at an early timing. The process model obtained can be used to create an effective LQG controller, which in addition to being capable of suppressing disturbances and following a reference signal, also is capable of producing relatively smooth control signals under noisy conditions.

## VIII. REFERENCES

- [1] S. Onishi, S. Hong Jo, K. Shoda, P Do Jo, S. Kato, "Active Thermo-Atmosphere Combustion (ATAC) – A New Combustion Process for Internal Combustion Engines", SAE790501
- [2] R. Johansson, "System Modeling and Identification", Prentice Hall, Englewood Cliffs, NJ, 1993
- [3] L. Ljung, "System Identification, Theory for the user", Prentice Hall 1999
- [4] J-O. Olsson, P. Tunestål, B. Johansson, "Closed-Loop Control of an HCCI Engine", SAE 2001-01-1031
- [5] D. Bown, "The Dynamic Transfer Characteristics of Reciprocating Engines", Proc. Inst. Mech. Engrs., Vol. 185, pp.185-201, 1971
- [6] D.B. Welbourn, D.K. Roberts, R.A. Fuller, (1959) *Governing of Compression-Ignition Oil Engines*, Proc. Inst. mech. Engrs., Vol. 173, pp. 575-604.
- [7] J. Hyvönen, G. Haraldsson, B. Johansson, "Balancing Cylinder-To-Cylinder Variations in a Multi-Cylinder VCR-HCCI-Engine", SAE 2004-01-1897
- [8] G. Haraldsson, J. Hyvönen, P. Tunestål, B. Johansson, "HCCI Combustion Phasing with Closed-Loop Combustion Control Using Variable Compression Ratio in a Multi Cylinder Engine", JSAE 200301126/SAE 2003-01-1830
- [9] G. Haraldsson, J. Hyvönen, P. Tunestål, B. Johansson, "HCCI Closed Loop Combustion Control using Fast Thermal Management", SAE 2004-01-0943
- [10] K. J. Åström, B. Wittenmark, "Computer-Controlled Systems: Theory and Design", Prentice Hall, 1997

## IX. CONTACT

Roland Pfeiffer, MSc C.S.

E-mail: [roland.pfeiffer@vok.lth.se](mailto:roland.pfeiffer@vok.lth.se)

Göran Haraldsson MSc M.E.

E-mail: [goran.haraldsson@vok.lth.se](mailto:goran.haraldsson@vok.lth.se)

Per Tunestål, Assistant Professor

E-mail: [per.tunestal@vok.lth.se](mailto:per.tunestal@vok.lth.se)

Bengt Johansson, Professor

E-mail: [bengt.johansson@vok.lth.se](mailto:bengt.johansson@vok.lth.se)

Department of Heat and Power Engineering, Division of Combustion Engines, Lund Institute of Technology, P.O. Box 118, SE-221 00 Lund, Sweden.

Rolf Johansson, Professor

E-mail [rolf.johansson@control.lth.se](mailto:rolf.johansson@control.lth.se)

Department of Automatic Control, Lund Institute of Technology, P.O. Box 118, SE-221 00 Lund, Sweden.

Jan-Ola Olsson, PhD

E-mail: [jolssso56@volvocars.com](mailto:jolssso56@volvocars.com)

Volvo Car Corporation