



LUND UNIVERSITY

Measurements of Turbulent Flame Speed and Integral Length Scales in a Lean Stationary Premixed Flame

Klingmann, Jens; Johansson, Bengt

Published in:
SAE technical paper series

1998

[Link to publication](#)

Citation for published version (APA):

Klingmann, J., & Johansson, B. (1998). Measurements of Turbulent Flame Speed and Integral Length Scales in a Lean Stationary Premixed Flame. *SAE technical paper series, 107*(SAE Technical Paper 981050). <http://www.sae.org/technical/papers/981050>

Total number of authors:
2

General rights

Unless other specific re-use rights are stated the following general rights apply:
Copyright and moral rights for the publications made accessible in the public portal are retained by the authors and/or other copyright owners and it is a condition of accessing publications that users recognise and abide by the legal requirements associated with these rights.

- Users may download and print one copy of any publication from the public portal for the purpose of private study or research.
- You may not further distribute the material or use it for any profit-making activity or commercial gain
- You may freely distribute the URL identifying the publication in the public portal

Read more about Creative commons licenses: <https://creativecommons.org/licenses/>

Take down policy

If you believe that this document breaches copyright please contact us providing details, and we will remove access to the work immediately and investigate your claim.

LUND UNIVERSITY

PO Box 117
221 00 Lund
+46 46-222 00 00

Measurements of Turbulent Flame Speed and Integral Length Scales in a Lean Stationary Premixed Flame

Jens Klingmann and Bengt Johansson
Lund Institute of Technology

Reprinted From: **SI Engine Combustion**
(SP-1315)

The appearance of this ISSN code at the bottom of this page indicates SAE's consent that copies of the paper may be made for personal or internal use of specific clients. This consent is given on the condition, however, that the copier pay a \$7.00 per article copy fee through the Copyright Clearance Center, Inc. Operations Center, 222 Rosewood Drive, Danvers, MA 01923 for copying beyond that permitted by Sections 107 or 108 of the U.S. Copyright Law. This consent does not extend to other kinds of copying such as copying for general distribution, for advertising or promotional purposes, for creating new collective works, or for resale.

SAE routinely stocks printed papers for a period of three years following date of publication. Direct your orders to SAE Customer Sales and Satisfaction Department.

Quantity reprint rates can be obtained from the Customer Sales and Satisfaction Department.

To request permission to reprint a technical paper or permission to use copyrighted SAE publications in other works, contact the SAE Publications Group.



GLOBAL MOBILITY DATABASE

All SAE papers, standards, and selected books are abstracted and indexed in the Global Mobility Database

No part of this publication may be reproduced in any form, in an electronic retrieval system or otherwise, without the prior written permission of the publisher.

ISSN 0148-7191

Copyright 1998 Society of Automotive Engineers, Inc.

Positions and opinions advanced in this paper are those of the author(s) and not necessarily those of SAE. The author is solely responsible for the content of the paper. A process is available by which discussions will be printed with the paper if it is published in SAE Transactions. For permission to publish this paper in full or in part, contact the SAE Publications Group.

Persons wishing to submit papers to be considered for presentation or publication through SAE should send the manuscript or a 300 word abstract of a proposed manuscript to: Secretary, Engineering Meetings Board, SAE.

Printed in USA

Measurements of Turbulent Flame Speed and Integral Length Scales in a Lean Stationary Premixed Flame

Jens Klingmann and Bengt Johansson

Lund Institute of Technology

Copyright © 1998 Society of Automotive Engineers, Inc.

ABSTRACT

Turbulent premixed natural gas - air flame velocities have been measured in a stationary axi-symmetric burner using LDA. The flame was stabilized by letting the flow retard toward a stagnation plate downstream of the burner exit. Turbulence was generated by letting the flow pass through a plate with drilled holes. Three different hole diameters were used, 3, 6 and 10 mm, in order to achieve different turbulent length scales. Turbulent integral length scales were measured using two-point LDA and the stretching in terms of the Karlovitz number could be estimated from these measurements. The results support previous studies indicating that stretching reduces the flame speed.

INTRODUCTION

The emissions of nitric oxides from a spark ignition engine can be much reduced if a diluted air/fuel mixture is used. This dilution can be with excess air (lean burn) or with any inert media like exhaust gas recycled (EGR). In both these cases the limit of dilution is set by the combustion process. The cylinder charge is in the S.I. engine burned by a propagating turbulent flame, starting at the spark plug and ending at the cylinder wall. The speed with which the flame progresses is known to depend on the turbulence in the cylinder and the laminar flame speed, S_L , of the charge. With a lean mixture S_L is known to decrease. At some point S_L becomes zero and the flammability limit is reached. If lean operation of the engine is desired the engine should be operated with a mixture fraction only marginally richer than this limit. The problem with this operation, however, is that the combustion rate is very slow resulting in low engine efficiency. To compensate for the low laminar flame speed, an increase in turbulence can be used. This concept with increased turbulence for lean burn engine is well adapted [1,2].

The problem with the high level of turbulence is that the ratio of turbulent to laminar flame speed, S_T/S_L , will be high. As a consequence there will be problems with tur-

bulent quenching of the flame. This turbulent quenching will take place at an air/fuel ratio, λ , richer than the laminar flame limit and will hence limit engine operation. The work presented intends to focus on the turbulence effects on the quenching process. A first step in this direction is to measure the turbulent flame speed as a function of λ and turbulence parameters. The major parameters are turbulent rms. value, u' , and length scales, e.g. the integral scale, l_i .

In order to avoid the inherent experimental difficulties of combustion engines such as poor optical access and cycle to cycle variations, the experiments are made in a stationary atmospheric burner. A stationary flow also makes control of the turbulence easier and enables us to use two-point LDA to determine the integral length scale. An important difference between flame speed measurements in a stationary burner and measurements in a bomb or in an engine is that there is no flame kernel that grows from sizes smaller than the turbulent length scales. The flame in a burner is much larger than the integral length scale and the entire turbulent spectrum will effect the flame [3,4]. Further, bomb or engine experiments are carried out in decaying turbulence and since smaller scales decay faster the turbulence spectrum is shifted towards larger scales [4]. This is not the case in a stationary burner.

Many experiments have been made to determine the influence of turbulence on premixed flame speed but the scatter of the data is high and there is no accepted universal dependency. Liu and Lenze [5] studied different $\text{CH}_4\text{-H}_2\text{-air}$ mixtures in a turbulent stagnation burner similar to the one used in this experiment. They found that flame speed could well be described by

$S_T = S_L + 5.3 \sqrt{S_L} u'$ and that neither l_i nor the specific $\text{CH}_4\text{-H}_2\text{-air}$ mixture resulting in a certain laminar flame speed had any significant influence.

Abdel-Gayed et al [3] compiled a large number of different experiments and argued that a general expression must be based on suitable non-dimensional groups such as S_T/S_L , u'/S_L , and the stretching of the flame

expressed as the Karlovitz number $Ka = (u'/l_T)(\delta/S_L)$. Here l_T is the Taylor micro scale and δ is the laminar flame thickness. Also the Lewis number, Le , which is the ratio of the transport coefficients for energy and mass, is of importance. Relevant dimension-less groups and their values in engines and stationary burners will be discussed further.

EXPERIMENTAL APPARATUS

BURNER – The burner is based on a coaxial flow with air/fuel mixture in the center and a supporting air flow surrounding the core, as shown in figure 1. The flow is subjected to a contraction (area ratio of four and an outlet diameter of 100 mm) in order to minimize flow disturbances. Both air mass flows are monitored and the air mass flow to the core is used to regulate the fuel mass flow to the desired λ . After the contraction the flow is directed towards a water cooled stagnation plate and thus the centerline speed is retarded from the exit velocity to zero. If the exit velocity is higher than the flame velocity the flame will stabilize at some distance from the stagnation plate. This distance is of course dependent on these velocities. Influences from the cooled stagnation plate are believed to be negligible if the flame is stabilized at a distance from the stagnation plate which is large compared to the quenching distance, d_q . All our measurements were made at more than five d_q from the stagnation plate. Laminar and turbulent diffusion at the interface between the air/fuel mixture and the supporting air will increase l at the edges and, if the stagnation plate is placed far downstream of the contraction, the centerline will also be affected. A drilled hole in the stagnation plate allows us to extract burned gas from the centerline and λ estimates from the oxygen content showed agreement with the mass flow meters. The temperature of the unburned gas was $23 \pm 3^\circ C$.

Turbulence can be generated by placing a flat plate with drilled holes on top of the contraction. Three plates, with 3, 6 and 10 mm holes with a solidity of 50% have been used in this investigation. All burning measurements were made using Danish natural gas as fuel. The content of the fuel is shown in table 1 below.

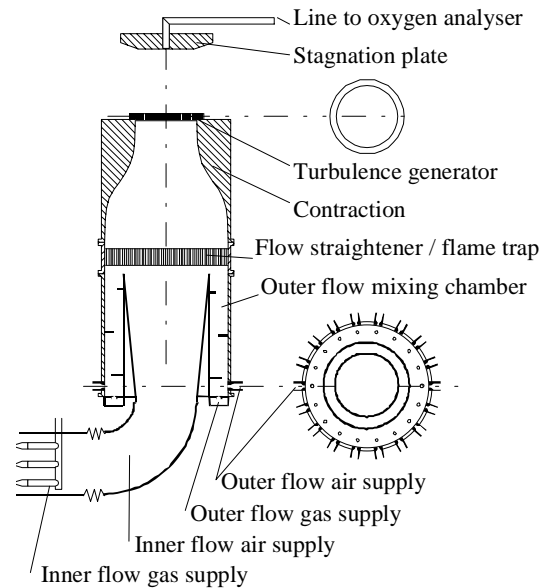

Figure 1. Burner.

Table 1. Gas content.

Species	% by vol.
CH4	91.03
C2H6	4.73
C3H8	1.72
C4H10	1.46
CO2	0.49
N2	0.58

MEASUREMENT SYSTEM – LDA measurements were made on the centerline using a Dantec 2-component fiber based system illuminated by a Spectra Physics water cooled Argon laser. A $1.92 \times$ expander and a $1.5 \times$ focusing expander with 600 mm focal length reduced the measuring volume to approximately 60 by 700 μm . Velocities were computed by Dantec burst spectrum analyzers. Silicon carbide particle with a mean diameter of 1.5 microns were added to the air stream.

The two-point measurements were made by shifting the optical fibers so that the same velocity component is measured twice. By letting the beams pass two mirrors the measuring point could be separated by an adjustable distance, see figure 2.

The size of the measuring volume determines the scales which can be resolved. For this reason the focusing expander was replaced with a $3.75 \times$ expander and a front lens with 480 mm focal length yielding a measuring volume of approximately 22 by 160 μm . Oil droplets with a mean diameter of 0.6 μm from a TSI atomizer were used for the non burning measurements.

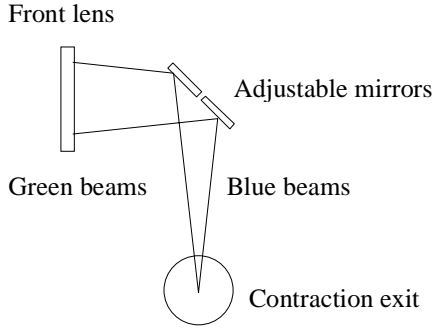

Figure 2. Optical layout for two-point measurements.

Laser induced fluorescence was used to visualize the flame front. A Kr-F Excimer laser with a pulse energy of 150 mJ per pulse at 248 nm was used to induce fluorescence in small amounts of acetone added to the fuel. A Princeton Instruments intensified CCD camera was used to capture an image of the planar laser sheet.

RESULTS

TURBULENT INTEGRAL LENGTH SCALES – Integral length scales can be defined from the two-point correlation:

$$I_1^{\text{Spanwise}}(\mathbf{x}) = \int_0^{\infty} C_{uu,y}(\mathbf{x}, dy) dy$$

where

$$C_{uu,y} = \frac{\overline{u(\mathbf{x}) u(\mathbf{x} + dy)}}{u'(\mathbf{x}) u'(\mathbf{x} + dy)}$$

Here u denotes the instantaneous velocity fluctuation, the over bar a time average and dy is the separation distance. Coordinate and velocity directions can be seen in figure 3.

A typical measurement of the two-point correlation can be seen in figure 4. Measurements at $dy = 0$, where the correlation is one by definition, will use the same seeding particle and hence do not reflect the spatial resolution of the measuring system, [6].

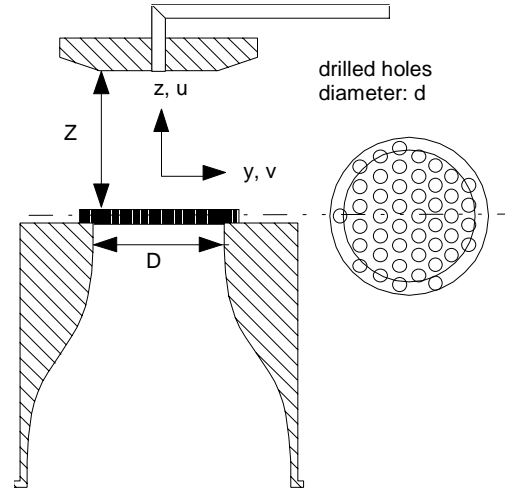

Figure 3. Test section.

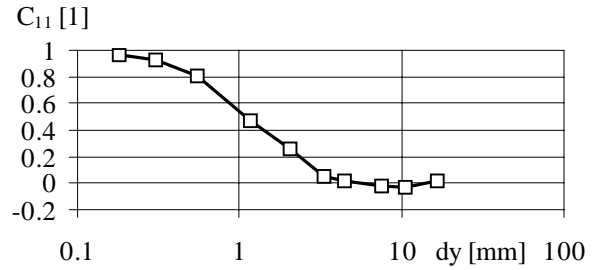

Figure 4. Spanwise two-point correlation at $U_{\text{exit}} = 1.96$ m/s, 6 mm grid, $z = 37.5$, $Z = 54.9$ mm.

In isotropic turbulence:

$$I_1^{\text{Streamwise}}(\mathbf{x}) = \int_0^{\infty} C_{uu,z}(\mathbf{x}, dz) dz \approx 2 I_1^{\text{Spanwise}}(\mathbf{x})$$

This is also the scale which would be obtained from HWA measurements using Taylor's hypotheses. Casting the relationship between I_1 , U_{exit} , D , d , Z , z and $v = \mu / \rho$ into dimensionless form yields e.g.:

$$\frac{I_1}{d} = f\left(\frac{U_{\text{exit}} d}{v}, \frac{D}{d}, \frac{z}{d}, \frac{Z}{d}\right)$$

Neglecting the influences of D/d and assuming that this relationship can be rewritten as the product of independent functions reduces the relationship to:

$$\frac{I_1}{d} = f_1(\text{Re}_{\text{exit}}) f_2\left(\frac{z}{d}\right) f_3\left(\frac{Z}{d}\right)$$

where Re_{exit} is based on U_{exit} and d .

Figure 5 and 6 below show the fit of the streamwise integral length scale to

$$l_I / d = (c_1 z / d + c_2) \text{Re}_{\text{exit}}^{c_3} (Z / d)^{c_4}$$

with the z/d and Z/d dependence separated. The values of the constants are: $c_1 = 13.604$, $c_2 = -51.369$, $c_3 = 0.22$, $c_4 = -1.194$. It can be noted that the Reynolds number dependence is weak in comparison to the other parameters.

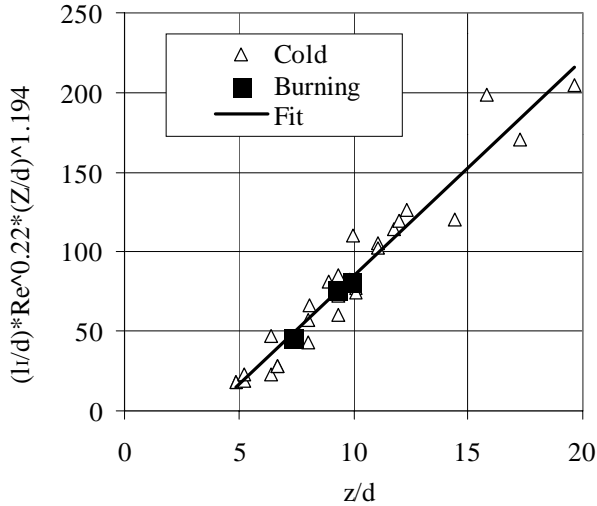

Figure 5. Non-dimensional streamwise integral length scale at centerline as a function of non-dimensional streamwise coordinate.

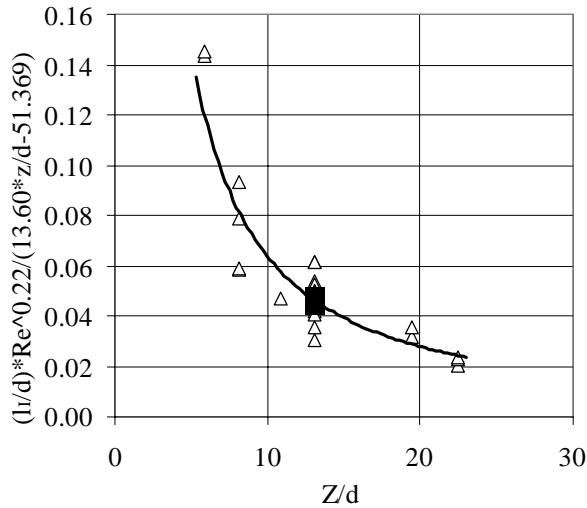

Figure 6. Non-dimensional streamwise integral length scale at centerline as a function of the non-dimensional position of the stagnation plate. Legend as in figure 5.

It can be seen that the relationship between normalized integral scale and position is almost linear, as would be expected in a single free jet in the self similar region. Most measurements were made cold and spanwise, but no deviations for the streamwise or burning measurements could be seen.

Karlovitz strain rate parameters can now be estimated if the Taylor micro scale is related to the integral scale [3]:

$$\left. \begin{aligned} \text{Ka} &= \frac{\delta}{S_L} \frac{u'}{l_T} \\ \delta_L &= \nu / S_L \\ l_T^2 / l_I &= A \nu / u' \\ A &= 40.4 \end{aligned} \right\} \text{Ka} = 0.157 (u'/S_L)^2 \text{Re}_{l_I}^{-1/2}$$

Here Re_{l_I} is based on u' and l_I .

Also the Damköhler number, Da , can be estimated from the integral length scale by:

$$\text{Da} = \frac{\tau_T}{\tau_L} = \frac{l_I / u'}{\delta / S_L}$$

where τ_T is a turbulent time scale corresponding to l_I and τ_L is a characteristic chemical reaction time, here approximated by the residence time in a laminar flame.

TRACER LIF – Samples of the flame front visualized by tracer LIF can be seen in figure 7 which shows three consecutive images for the three different cases in table 2. The turbulent rms. values here are estimated from one-point measurements of similar cases and should be regarded as rough estimates. This of course effects

Re_{l_I} , Ka and Da . All integral length scales are streamwise

Table 2. Estimated dimensionless groups for the LIF images in figure 7. Karlovitz number for case A is omitted due to the low Reynolds number at which the estimate for the Taylor micro scale is invalid.

Case	u'/S_L	l_I/δ	Re_{l_I}	Ka	Da
A	0.055	46	3	-	836
B	1.29	81	155	0.021	63
C	4.66	43	301	0.196	9.2

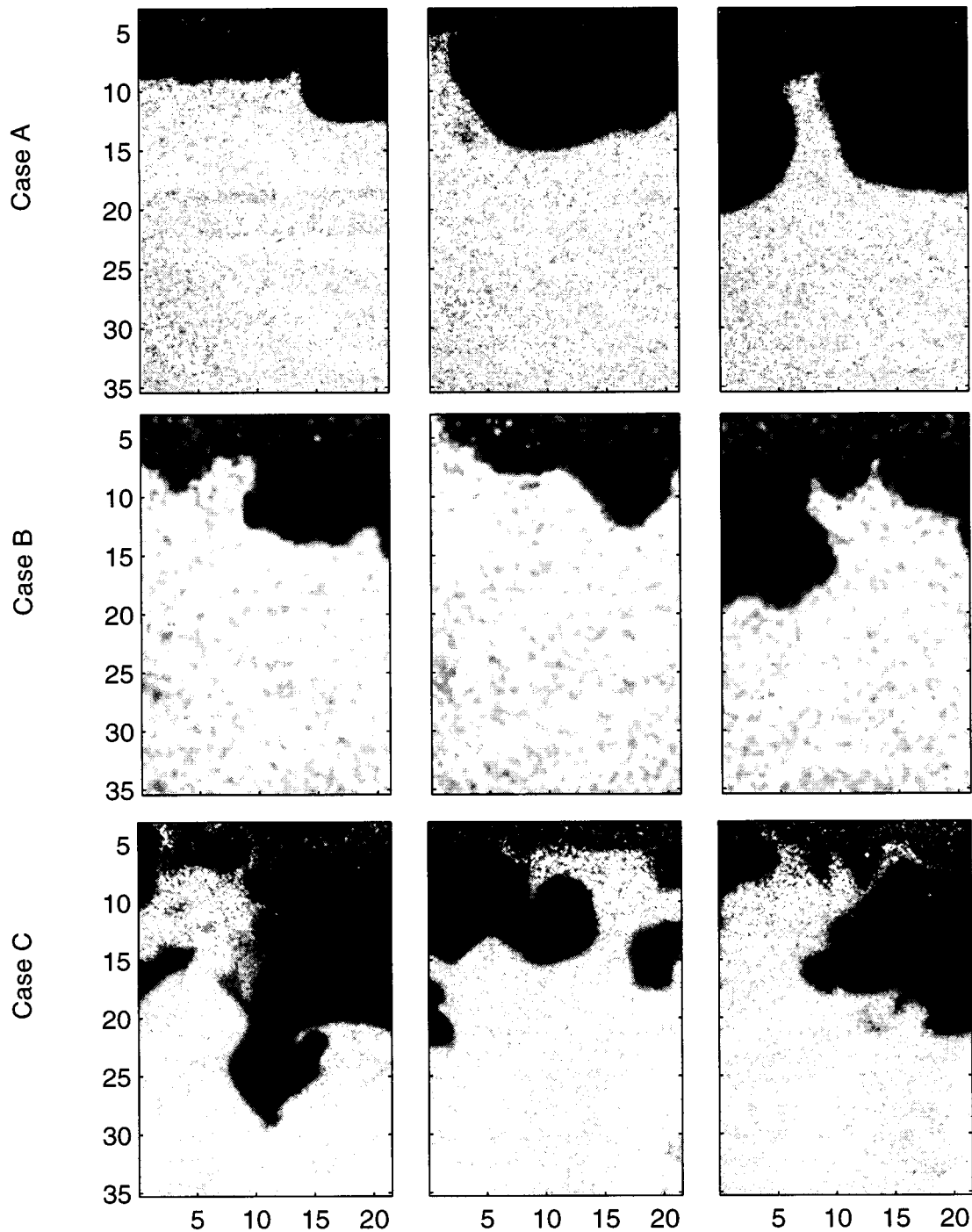

Figure 7. Flame front visualization by tracer LIF. The ordinate is the distance from the stagnation plate, Z-z, and the abscissa is the distance from the centerline, both in millimeters.

FLAME VELOCITIES. – Turbulent flame velocities were determined by measuring the centerline velocity through the flame. Normally the minimum velocity in front of the flame should be taken as the turbulent flame velocity, as shown in figure 8, but this was not applicable to very lean flames which did not show any minimum here. This is shown in figure 9. Instead the flame velocity was estimated to be the velocity where the second derivative is at its maximum. In the cases where both methods were applicable the minimum velocity was a few percent lower. No influence of the flame on the rms. values can be seen,

but near the stagnation plate the normal component, u' , is damped and v' is increased.

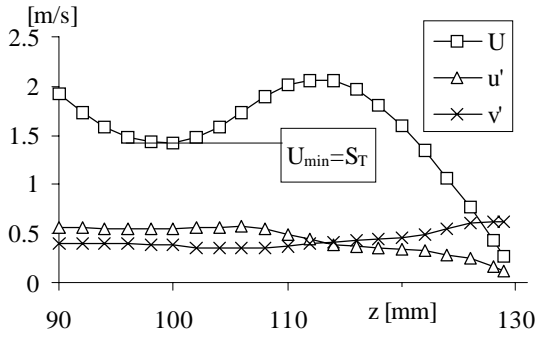

Figure 8. Centerline velocities at $\lambda = 1.34$, $U_{\text{exit}} = 4.12$ m/s, $Z = 131$ mm and $d = 10$ mm.

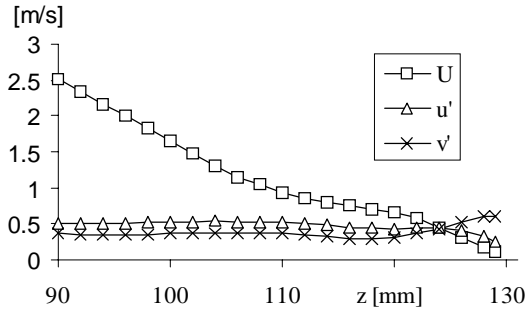

Figure 9. Centerline velocities at $\lambda = 1.69$, $U_{\text{exit}} = 4.11$ m/s, $Z = 131$ mm and $d = 10$ mm.

Figure 10 shows a plot of S_T/S_L versus u'_{iso}/S_L , where

$u'_{\text{iso}} = \left[\frac{(\overline{u'u'} + 2\overline{v'v'})}{3} \right]^{1/2}$. Lines are adapted from Abdel-Gayed et al [3] and show the average of many different experiments with the Lewis number ≤ 1.3 . Despite great differences in experiment and data reduction the general agreement is fairly good.

A more complete listing of the data of figure 10 given in table 3. The laminar flame thickness, on which the Damköhler number is based, is computed from

$$\delta = \nu / S_L$$

No correlation between S_L and S_T/u' , as suggested by Liu and Lenze [5], could be seen. The Karlovitz numbers in this experiment range from low to moderate. Higher values most likely require a different flame stabilization method e.g. using swirl.

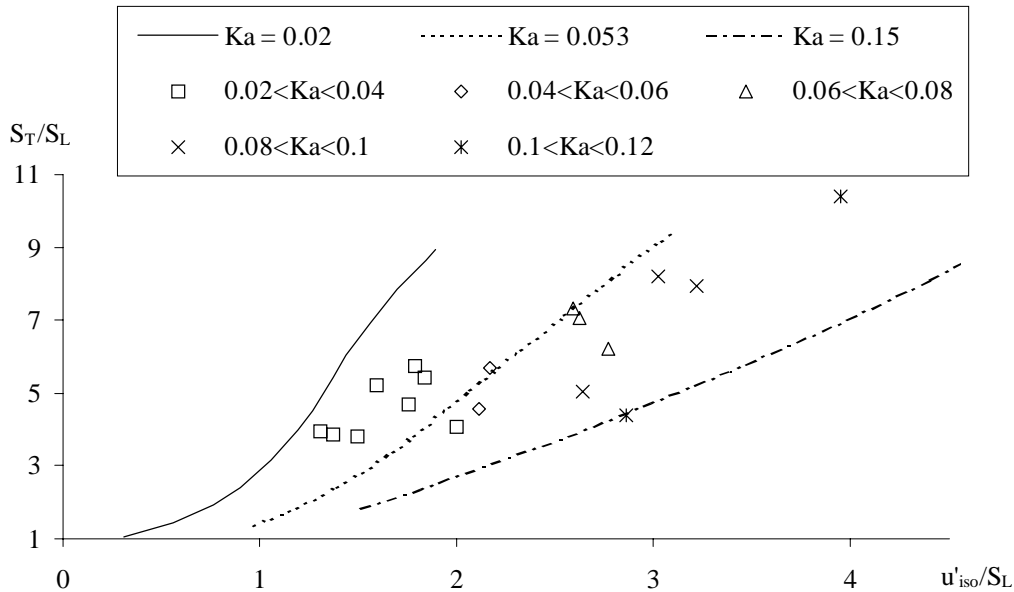

Figure 10. Non-dimensional turbulent flame speed versus non-dimensional isotropic turbulence. Lines are adopted from [3].

Table 3. Flame velocity measurements.

d	Z/d	U_{exit}	λ	S_T	S_T/S_L	u'_{iso}	u'_{iso}/S_L	l_I	δ	Re_{l_I}	Da	Ka
[mm]	[1]	[m/s]	[1]	[m/s]	[1]	[m/s]	[m/s]	[mm]	[mm]	[1]	[1]	[1]
3	11.43	3.00	1.44	0.90	4.38	0.588	2.859	3.7	0.0733	143	17.5	0.107
3	11.43	4.43	1.33	1.32	5.02	0.692	2.640	3.4	0.0576	156	22.5	0.087
6	11.37	3.59	1.37	1.47	6.23	0.655	2.772	5.8	0.0638	253	32.9	0.076
6	11.37	5.88	1.33	2.06	7.93	0.834	3.214	5.5	0.0582	302	29.2	0.093
10	13.10	2.03	1.60	0.60	3.83	0.217	1.374	10.3	0.0957	147	78.2	0.024
10	13.10	2.02	1.68	0.55	3.81	0.216	1.491	10.6	0.104	151	68.0	0.028
10	13.10	3.27	1.47	1.07	5.45	0.361	1.834	8.2	0.0767	196	58.3	0.038
10	13.10	3.27	1.58	0.93	5.67	0.356	2.167	8.7	0.0919	205	43.6	0.052
10	13.10	3.26	1.74	0.97	7.04	0.360	2.624	8.8	0.110	211	30.6	0.074
10	13.10	4.11	1.69	1.17	8.18	0.434	3.023	8.6	0.105	248	27.2	0.091
10	13.10	4.10	1.55	1.25	7.33	0.442	2.591	8.3	0.0885	244	36.3	0.068
10	13.10	4.12	1.34	1.46	5.73	0.453	1.783	7.5	0.0594	227	71.3	0.033
10	13.10	4.09	1.26	1.58	5.22	0.480	1.588	7.3	0.0499	233	92.5	0.026
10	13.10	2.60	1.75	0.62	4.53	0.289	2.114	9.7	0.110	186	41.7	0.051
10	13.10	2.60	1.57	0.78	4.69	0.290	1.756	9.0	0.0912	173	56.1	0.037
10	9.22	3.83	1.47	2.04	10.37	0.775	3.946	9.2	0.0769	474	30.4	0.112
10	9.22	2.04	1.29	1.16	4.09	0.569	1.999	9.5	0.0530	357	89.4	0.033

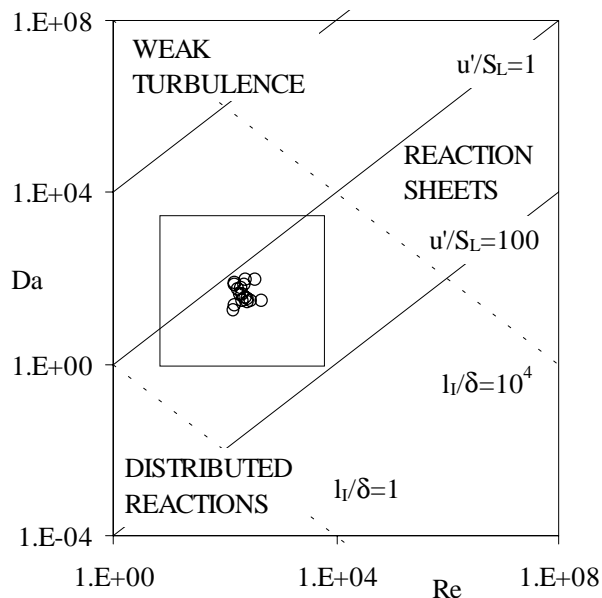

Figure 11. Illustration of regimes of turbulent combustion. Rectangle identifies combustion regimes of engine operating conditions. Adopted from Abraham et al [7]. Rings denote estimated values of experiments in this investigation.

Combustion regimes are often illustrated by a plot of the Damköhler number versus the turbulent Reynolds number. This is done in figure 11 which is adopted from Abraham et al [7], who also indicate a regime of typical engine values. The values of table 3 can be seen to fall within this regime.

CONCLUSIONS

Turbulent flame velocities and integral scales have been measured using one- and two-point LDA. These mea-

surements have been used to correlate turbulent flame speed to air/fuel ratio, rms. turbulent fluctuations and the Karlovitz stretch factor, estimated from measurements of the integral length scale.

The results support the concept that turbulent enhancement of flame speed is influenced by stretching. Despite very different experimental methods, data is in fairly good agreement with the work of from Abdel-Gayed et al [3].

No influence of laminar flame speed on the relationship between S_T/S_L and u'/S_L could be seen.

ACKNOWLEDGMENTS

The financial support from the Swedish National Board for Industrial and Technical Development is gratefully acknowledged.

REFERENCES

1. K. Horie, K. Nishizawa, T. Ogawa, S. Akazaki, K. Miura. "The Development of a High Fuel Economy and High Performance Four-Valve Lean Burn Engine", SAE paper 920455.
2. D. Bradley, C. G. W. Sheppard, "Limitations to turbulence-enhanced burning rates in lean burn engines", I.Mech.E. C46/88, 1988.
3. R.G. Abdel-Gayed, D. Bradley and M. Lawes, "Turbulent burning velocities: a general correlation in terms of straining rates", proc. R. Soc. Lond. A 414, p 389-413, 1987.
4. M. D. Checkel, D. S-K. Ting, "Measuring Turbulent Flame Growth by Visualization" SAE paper 920184.
5. Y. Liu, B. Lenze: The influence of turbulence on the burning velocity of premixed CH₄-H₂ flames with different laminar burning velocities, 22nd Symposium on combustion/The Combustion Inst. p 747-754, 1988.
6. G. Johansson, J. Klingmann, "An LDA based method for accurate measurements of the dissipation rate tensor with application to a circular jet", 7Th int. symposium on applications of Laser techniques to fluid mech. 25.2, 1994.
7. J. Abraham, F. A. Williams, F. V. Bracco, "A Discussion of Turbulent Flame Structure in Premixed Charges", SAE paper 850345.