



LUND UNIVERSITY

A handbook formula for the inductance of a single-layer circular coil

Lundin, Richard

Published in:
Proceedings of the IEEE

1985

[Link to publication](#)

Citation for published version (APA):

Lundin, R. (1985). A handbook formula for the inductance of a single-layer circular coil. *Proceedings of the IEEE*, 73(9), 1428-9. <http://ieeexplore.ieee.org/iel5/5/31353/01457572.pdf?tp=&arnumber=1457572&isnumber=31353>

Total number of authors:

1

General rights

Unless other specific re-use rights are stated the following general rights apply:

Copyright and moral rights for the publications made accessible in the public portal are retained by the authors and/or other copyright owners and it is a condition of accessing publications that users recognise and abide by the legal requirements associated with these rights.

- Users may download and print one copy of any publication from the public portal for the purpose of private study or research.
- You may not further distribute the material or use it for any profit-making activity or commercial gain
- You may freely distribute the URL identifying the publication in the public portal

Read more about Creative commons licenses: <https://creativecommons.org/licenses/>

Take down policy

If you believe that this document breaches copyright please contact us providing details, and we will remove access to the work immediately and investigate your claim.

LUND UNIVERSITY

PO Box 117
221 00 Lund
+46 46-222 00 00

Table 1 The Input Impedance of the Dipoles of the Array Given in Fig. 3 for Several Values of their Length and $d/\lambda = 0.5$

$2h/\lambda$	Z_1 and Z_3 ($Z_1 = Z_3$) Left and Right Dipole	Z_2 Middle Dipole
0.25	$17.1 - j521.6$	$16.7 - j626.7$
0.50	$87.3 + j71.6$	$73.3 + j128.6$
0.75	$394.5 + j837.3$	$365.2 + j1063.4$
1.0	$472.1 - j652.6$	$401.2 - j1538.7$

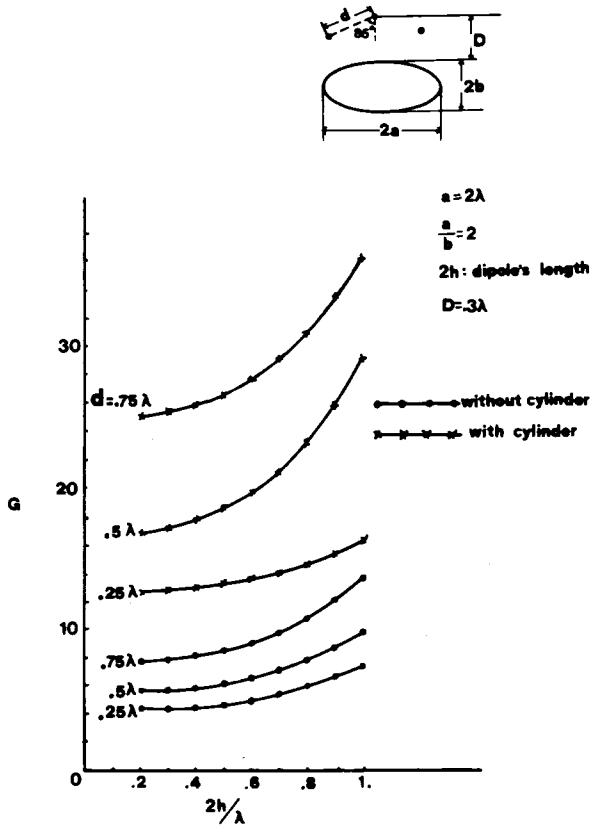

Fig. 3. Maximum gain of a three $\lambda/2$ dipole array near an elliptic cylinder as a function of the dipoles length and mutual distance.

III. CONCLUSION

The maximum gain of arrays of wire antenna near an elliptic cylinder was presented. The hybrid MM-GTD technique was used. Three-dipole arrays were considered in the presence of the elliptic cylinder.

The whole procedure has shown that an array in free space has different feed voltages and less optimum gain than an array in the presence of the elliptic cylinder. It was also shown that a good selection of the length of the dipoles depends on the gain requirement, the sidelobe level, and the impedance of the dipoles.

REFERENCES

- [1] J. H. Richmond, "Computer program for thin-wire structures in a homogeneous conducting medium," NTIS, Springfield VA, NASA Contrador Rep. CR-2399, 1973.
- [2] G. A. Thiele and T. H. Newhouse, "A hybrid technique for combining moment methods with the geometrical theory of diffraction," *IEEE Trans. Antennas Propagat.*, vol. AP-23, Jan. 1975.
- [3] K. Siakavara, H. Papadimitraki-Chlichlia, and J. N. Sahalos, "On the treatment of wire antennas near an elliptic cylinder," *Arch. für Electrotech.*, to be published.
- [4] K. Siakavara, H. Papadimitraki-Chlichlia, J. N. Sahalos, and G. A. Thiele, "Two hybrid techniques for treatment of wire antennas near an elliptic cylinder," in *Proc. Nat. Radio Science Meet. (URSI)*, p. 81, California 1981.
- [5] J. N. Sahalos, "Optimization methods for arrays of nonparallel wire antennas," Ohio State Univ., ElectroScience Lab., Tech. Rep. 4372-1,

- 1977.
- [6] E. P. Ekelman and G. A. Thiele, "A hybrid technique for combining the moment method treatment of wire antennas with the GTD for curved surfaces," *IEEE Trans. Antennas Propagat.*, vol. AP-28, pp. 831-839, 1980.
- [7] L. W. Henderson and G. A. Thiele, "A hybrid MM-GTD technique for treatment of wire antennas near a curved surface," *Radio Sci.*, vol. 16, pp. 1125-1130, 1981.
- [8] R. F. Harrington, *Field Computation By Moment Method*. London, England: Macmillan, 1968, ch. 10, pp. 189-202.

A Handbook Formula for the Inductance of a Single-Layer Circular Coil

RICHARD LUNDIN

A compact six-figure approximation formula for the inductance of a cylindrical current sheet is presented. The formula displays the correct asymptotic behavior in the respective cases of very long and very short coils. The efficiency of the approximation formula is due to a thorough analysis of the exact formula.

INTRODUCTION

A single-layer circular coil can be idealized to a cylindrical current sheet [1]. The exact formula for the inductance of such a current sheet was first given by Lorenz and more recently by Wheeler [2] in a letter to the PROCEEDINGS OF THE IEEE. Wheeler states that the exact formula, involving elliptic integrals, is too complicated for practical use. He subsequently presents three different approximation formulas. They all differ in accuracy and structure from the approximation formula presented in this letter.

ANALYTICAL PROPERTIES

Introduce

- a radius of coil,
- b axial length of coil,
- n number of turns,
- μ_0 permeability of vacuum,
- L inductance of current sheet.

Then

$$L = \frac{\mu_0 n^2 \pi a^2}{b} f\left(\frac{2a}{b}\right) \quad (1)$$

where $2a/b$ is the shape ratio. The function f was tabulated by Nagaoka [3]; see Fig. 1.

It is obviously possible to rewrite (1) as

$$L = \mu_0 n^2 a g\left(\frac{b}{2a}\right). \quad (2)$$

The following statement is now made. The Nagaoka coefficient f can be expressed as

$$f\left(\frac{2a}{b}\right) = f_1\left(\frac{4a^2}{b^2}\right) - \frac{4}{3\pi} \frac{2a}{b} \quad (3)$$

and the function g can be written

Manuscript received November 5, 1984.

The author is with the Department of Electromagnetic Theory, Lund University Institute of Science and Technology, S-221 00 Lund, Sweden.

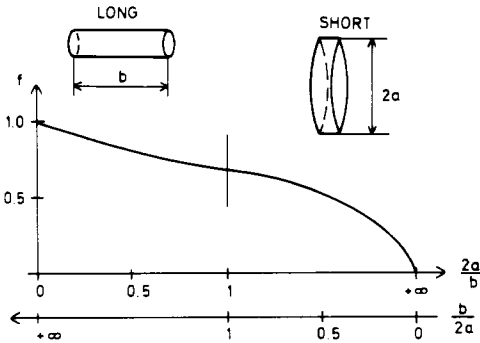

Fig. 1. The Nagaoka coefficient f .

$$g\left(\frac{b}{2a}\right) = \left[\ln\left(\frac{8a}{b}\right) - \frac{1}{2} \right] f_1\left(\frac{b^2}{4a^2}\right) + f_2\left(\frac{b^2}{4a^2}\right). \quad (4)$$

Equations (3) and (4) are valid for all current sheets and the same function f_1 appears twice. The latter, somewhat unexpected, fact is of practical value. It is possible to prove the simultaneous validity of (3) and (4) through using the theory of homogeneous linear differential equations in combination with the formulas of Butterworth [4].

The inductance of a long current sheet ($2a < b$) is preferably calculated through (1) and (3) while the inductance of a short current sheet ($2a > b$) is preferably calculated through (2) and (4). In order to cover the whole range of possible current sheets it is thus sufficient to approximate $f_1(x)$ and $f_2(x)$ on the interval $0 \leq x \leq 1$. It is possible to demonstrate that these functions are highly suited for polynomial approximation on this interval.

An explicit expression for f_1 is

$$\begin{aligned} f_1(x) &= \frac{1}{\sqrt{1+x}} {}_2F_1\left(\frac{5}{2}, \frac{1}{2}; 2; \frac{x}{1+x}\right) \\ &= \frac{1}{\sqrt{1+x}} \sum_{\nu=0}^{\infty} \frac{\left(\frac{5}{2}\right)_{\nu} \left(\frac{1}{2}\right)_{\nu}}{(\nu+1)\nu!} \left(\frac{x}{1+x}\right)^{\nu} \end{aligned} \quad (5)$$

where ${}_2F_1(\dots)$ is Gauss' hypergeometric function. Pochhammer's symbol is defined as

$$(c)_{\nu} = \frac{\Gamma(c+\nu)}{\Gamma(c)}.$$

An explicit expression for f_2 is

$$\begin{aligned} f_2(x) &= \frac{1}{2} \ln(1+x) f_1(x) \\ &+ \frac{1}{\sqrt{1+x}} \left\{ \sum_{\nu=1}^{\infty} \left[\frac{1}{3} + \frac{\left(\frac{5}{2}\right)_{\nu}}{\nu!} \Psi_{\nu} \right] \right. \\ &\left. \cdot \frac{\left(\frac{1}{2}\right)_{\nu}}{(\nu+1)!} \left(\frac{x}{1+x}\right)^{\nu} \right\} \end{aligned} \quad (6)$$

where

$$\Psi_1 = \frac{-47}{60} \quad (7)$$

and

$$\Psi_{\nu} = \Psi_{\nu-1} - \frac{12\nu+6}{(2\nu-1)2\nu(2\nu+2)(2\nu+3)}. \quad (8)$$

The range of the independent variable in (5) and (6) is $0 \leq x < +\infty$. Numerical function values are given in Table 1.

APPROXIMATION

The following "handbook formula" is asymptotically correct and yields the inductance with a maximum relative error less than 0.3×10^{-5} .

If $2a \leq b$ then

Table 1 Numerical Function Values

x	f_1	f_2
0.00	1.000 000	0.000 000
0.25	1.030 342	0.023 573
1.00	1.112 836	0.095 072
4.00	1.374 336	0.377 113

$$L = \frac{\mu_0 n^2 \pi a^2}{b} \left\{ f_1\left(\frac{4a^2}{b^2}\right) - \frac{4}{3\pi} \frac{2a}{b} \right\} \quad (9)$$

else $2a > b$ and

$$L = \mu_0 n^2 a^2 \left\{ \left[\ln\left(\frac{8a}{b}\right) - \frac{1}{2} \right] f_1\left(\frac{b^2}{4a^2}\right) + f_2\left(\frac{b^2}{4a^2}\right) \right\} \quad (10)$$

where

$$f_1(x) = \frac{1 + 0.383901x + 0.017108x^2}{1 + 0.258952x}, \quad 0 \leq x \leq 1 \quad (11)$$

$$f_2(x) = 0.093842x + 0.002029x^2 - 0.000801x^3, \quad 0 \leq x \leq 1. \quad (12)$$

The coefficients in (11) and (12) minimize the maximum relative error of the inductance.

DISCUSSION

The inductance is calculated to six-figure accuracy through the "handbook formula" (9)–(12). The same degree of accuracy is obtained by interpolation in Nagaoka's table [3]. Thus Nagaoka's table (160 function values) is contained in the "handbook formula."

In order to facilitate design work, a number of nomograms of the Nagaoka coefficient have been published in the electrotechnical literature. A compact approximation formula like the "handbook formula" can be considered as a powerful alternative to a nomogram.

CONCLUSION

The result presented is the simultaneous validity of (3) and (4) in which the functions f_1 and f_2 are highly suited for polynomial approximation. An easy to use six-figure "handbook formula" for the inductance of a cylindrical current sheet has, as a consequence, been computed and presented.

REFERENCES

- [1] F. W. Grover, *Inductance Calculations*. New York: Dover, 1962, pp. 142–147.
- [2] H. A. Wheeler, "Inductance formulas for circular and square coils," *Proc. IEEE*, vol. 70, pp. 1449–1450, 1982.
- [3] H. Nagaoka, "The inductance coefficients of solenoids," *J. Coll. Sci.*, vol. 27, pp. 18–33, 1909.
- [4] S. Butterworth, "On a method for deriving mutual- and self-inductance series," *Phil. Mag. J. Sci.*, vol. 31, pp. 276–285, 1916.

Comments on "Reference Node r Model"

ALI M. RUSHDI

Certain ambiguities and inconsistencies in the above titled letter¹ are pointed out.

The reference node r model in the above letter¹ is claimed to be a focal point for development of circuit diagnosis concepts. The Roytman and Swamy (R-S) method of circuit diagnosis [1] is claimed to be one of the many available results found within this model. However, the contents of the letter¹ indicate that this model is one

Manuscript received May 1, 1984.

The author is with the Department of Electrical Engineering, King Abdul Aziz University, Jeddah 21413, Saudi Arabia.

¹P. E. Gray, *Proc. IEEE*, vol. 71, pp. 902–904, July 1983.