



LUND UNIVERSITY

Selected research studies from Scandinavia : dedicated to professor Göran Fagerlund on his 60th anniversary November 11, 1997

Tuutti, Kyösti

1997

[Link to publication](#)

Citation for published version (APA):

Tuutti, K. (Ed.) (1997). *Selected research studies from Scandinavia : dedicated to professor Göran Fagerlund on his 60th anniversary November 11, 1997*. (Report TVBM 3078). Division of Building Materials, LTH, Lund University.

Total number of authors:

1

General rights

Unless other specific re-use rights are stated the following general rights apply:

Copyright and moral rights for the publications made accessible in the public portal are retained by the authors and/or other copyright owners and it is a condition of accessing publications that users recognise and abide by the legal requirements associated with these rights.

- Users may download and print one copy of any publication from the public portal for the purpose of private study or research.
- You may not further distribute the material or use it for any profit-making activity or commercial gain
- You may freely distribute the URL identifying the publication in the public portal

Read more about Creative commons licenses: <https://creativecommons.org/licenses/>

Take down policy

If you believe that this document breaches copyright please contact us providing details, and we will remove access to the work immediately and investigate your claim.

LUND UNIVERSITY

PO Box 117
221 00 Lund
+46 46-222 00 00

LUND UNIVERSITY
LUND INSTITUTE OF TECHNOLOGY
Division of Building Materials



SELECTED RESEARCH STUDIES FROM SCANDINAVIA

Dedicated to Professor Göran Fagerlund on his 60th anniversary
November 11, 1997

Report TVBM-3078
Lund • Sweden • 1997

LUND UNIVERSITY
LUND INSTITUTE OF TECHNOLOGY
Division of Building Materials

SELECTED RESEARCH STUDIES FROM SCANDINAVIA

Dedicated to Professor Göran Fagerlund on his 60th anniversary
November 11, 1997

Report TVBM-3078
Lund • Sweden • 1997

ISRN LUTVDG/TVBM--97/3078--SE(1-208)
ISSN 0348-7911 TVBM

Lund Institute of Technology
Division of Building Materials
Box 118
S-221 00 Lund, Sweden

Telephone: 46-46-2227415
Telefax: 46-46-2224427

Preface

Professor Göran Fagerlund is well known world wide in the field of concrete research and concrete technology. This book has been produced by colleagues in Scandinavia in order to celebrate the 60th anniversary of professor Göran Fagerlund on the 11th of November 1997.

The book contains selected articles from research in different areas. These articles are produced by scientists in Scandinavia working at universities, research institutions or industries. However, many of the articles are based upon professor Göran Fagerlund original ideas.

The origin of this volume was conceived by several of the authors independently of each other and received immediate mutual approval.

Britt Andersson and Marita Persson have assisted in the editorial as well as in the practical work.

I would like to thank all those who have contributed, specially

Jan-Gunnar Glave, Skanska Civil Engineering,

Rune Kjellman, Skanska AB,

Fredrik Winberg, Cementa AB

for sponsoring the activities.

Kyösti Tuutti

Contents

Jan Alemo and Pär Hansson Cementitious injection grouts - penetration ability	1
Johan Alexanderson A disadvantage of high performance concrete and a simple way to avoid it	5
Stig Bernander and Mats Emborg Early age thermal crack control - industrial benefits of new technology?	14
Stig Bernander On transmission of restraint via construction joints in concrete structures	22
Jan Byfors Industrilised site-cast concrete	28
Lennart Elfgren Material and structural testing and modelling of concrete	33
Per Fidjestøl Corrosion processes in high performance concrete - A new perception is required	40
Odd E Gjorv Concrete workability: A more basic approach needed	45
Ulf A Halvorsen Prevention of rebar-corrosion	57
Arne Hillerborg Approximate elastic moment calculation	66
Jan-Erik Jonasson Theoretical calculation of expulsion tests	72
Heikki Kukko Aspects on the control of frost resistance of concrete	79
Magne Maage The development of the use of silica fume in concrete in Norway	87
Anders Nielsen Porous materials - structure and properties	94
Lars-Olof Nilsson A history lesson on the development of and request for knowledge - prediction models for chloride ingress into concrete structures as an example	104
Per-Erik Petersson Reflections on scaling resistance testing of concrete	114
Paul Sandberg Penetrability of cement based grouts	130
Paul Sandberg Service life prediction of reinforced concrete structures in saline environment	139

Asko Sarja A vision on sustainable materials and structural engineering	153
Erik J Sellevold and Christine J Hauck Effect of curing temperature and silica fume on the pore structure of hardened cement paste	164
Åke Skarendahl Material technology - a key to improved productivity	170
Sven Thelandersson Control of cracking in concrete structures due to imposed strain	183
Kyösti Tuutti Assessment of service life for concrete structures	198

CEMENTITIOUS INJECTION GROUTS - PENETRATION ABILITY



Jan Alemo
D.Sc. Visiting Professor
Pär Hansson
M.Sc.
Vattenfall Utveckling AB
SE-814 26 ÄLVKARLEBY
SWEDEN



ABSTRACT

The current research situation concerning cement grouting and material science is briefly described. A new material parameter governing the penetration ability of cement grouts has been developed. An ongoing research programme dealing with the filtration stability of cementitious injection grouts is presented.

1 INTRODUCTION

Grouting is a method of sealing and reinforcing rock, soil and damaged concrete structures. Generally, holes are drilled into the structure or rock/soil mass in order to make the cracks or leached channels accessible to pump a fluid grout into the same. The fluid grout will harden or gel to form a, supposedly, durable mass with predicted mechanical properties.

A rough division of the different grout compounds into chemical and cementitious grouts can be made. This classification is especially rough concerning the chemical grouts which only common denominator is that they are all solutions, contrary of the cementitious ones that are suspensions of particles in water.

The cementitious grouts display several advantages to the chemical grouts. They are usually more durable and more compatible with the formation or structure to be grouted. Other benefits are the environmental friendliness and low costs.

To obtain a durable and high strength hardened cementitious grout, it is necessary for the grout to be stable in terms of bleeding and sedimentation. Furthermore the w/c-ratio should be kept as low as possible to avoid a porous cement paste. Extensive laboratory tests on stable, low w/c-ratio, injection grouts show that the most significant limitation to their penetrability is the tendency of cement grains to agglomerate into an impermeable filter cake. Grout refusal can also occur due to inappropriate rheology of the grout. Restrictions in penetrability due to the latter can

most often be eliminated using superplasticizer. The ability of a grout to pass constrictions of the flow path without clogging can be designated filtration stability.

2 CURRENT RESEARCH SITUATION

Research on the properties of cement grouts has been carried out to various extent since the method of cement grouting was established. Most of the research has been directed towards the fluid properties, i.e. rheology, of the grout while the interaction between cement particles has been paid less attention. This can be partially explained by that the particle interactions have become more influential on the penetration properties of cement grouts during more recent years due to the tendency to use grouts with lower w/c-ratios, in order to obtain more durable hardened grouts, and more finely ground cements than before. This brings that the cement particles have to act closer together in the suspension. Therefore, the particle interactions gain importance. Furthermore the aim of recent grouting operations is to penetrate finer cracks with cement grouts than used to be common practice. It is desirable to be able to penetrate cracks of an aperture in the 0.1 mm range. This has up to now been considered possible only by using chemical grouts.

3 ONGOING AND FUTURE RESEARCH WORK

The symptom of poor particle interaction properties of a cement grout is clogging of cement grains, and subsequent defiltration of water at the entrance, and constrictions, of the crack or channel. Filtration stability is defined as the ability of a particulate suspension, eg cement grout, to pass obstructions without defiltration to occur.

Filtration stability becomes the property that dominates the penetration ability of the grout when the aperture width is in the region of 0.3 mm and less. Accordingly this is an important property to investigate.

At Vattenfall Utveckling AB, Concrete Technology, a research programme concerning cement grouting has been running since the late 80's. Laboratory investigations have been performed using commercially available products and a large variety of test set ups. This has led to an understanding of how injection grouts behave during flow through narrow channels and to ideas concerning test procedures. Since then the research has been focused on defining a new material parameter that we have designated "filtration stability". This material parameter can only be evaluated when the grout is mixed and ready to use. Test methods have been developed that allows us to measure the ability of a grout to pass constrictions and narrow channels without the cement particles clogging together. One equipment, suitable for use on site, is the "filter pump", a piston operation suction device with a sieve mounted at the mouth of the cylinder [1].

Using this test equipment, we have discovered that the commercially available products vary with respect to filtration stability within wide limits. Figure 1 shows six examples where each example represents one composition of grout subjected to identical mixing effort based on different batches of cement.

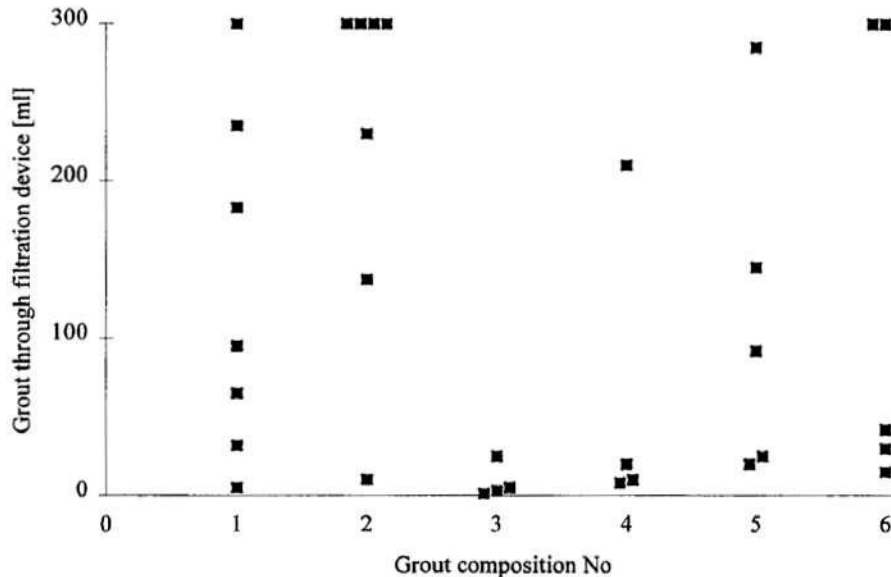

Figure 1 Natural variations in filtration stability, thus penetration ability, due to batchwise variations in cement properties.

In light of the experience gained during this earlier research work, we have arrived at the conclusion that in order to be able to improve the performance of cementitious grouts further, we have to investigate, and hopefully identify, the influential parameters on a more basic level. This incorporates studies on suspensions with inert particles where the actual physical and chemical properties of a cement suspension are added one or a few parameters at a time.

The research programme is subdivided as follows:

- State of the art.
- Grain size distribution of the cement.
- Morphology of the cement grains.
- Surface active additives.
- Pore water chemistry.
- Early gel formation.

At present, the state of the art report is nearly finished and some investigations concerning grain size distribution have been performed. The findings this far can be summarized in the following conclusions:

- The established rules-of-thumb concerning the filtration effect are not applicable to low w/c-ratio grouts. Regarding crack injection it is said that it is possible to grout if the crack width exceeds three times the maximum particle size of the cement. The corresponding rule for soil grouting is that the soil can be grouted if the quotient of the soil's grain size at 15 per cent passing to the cement's grain size at 85 per cent passing (D_{15}/d_{85}) is more than 20 to 25.
- The maximum grain size of the cement (d_{100}), d_{95} or d_{85} , is not as influential on the penetrability as it was considered earlier. The appearance of the entire grain size distribution curve contributes to the behaviour of the grout as well as pore water chemistry, physiochemical aspects and practical issues such as mixing efficiency.
- Filtration tests give a more reliable prediction of the penetrability than traditional rheological measurements.

When the programme is completed, it is our hope that better products for grouting purposes can be manufactured and that the quality of these products can be overseen appropriately.

4 ACKNOWLEDGEMENTS

The research work described has been financed by, in chronological order, Vattenfall, Elforsk and SKB.

5 REFERENCE

1. Hansson P. Filtration Stability of Cementitious Injection Grouts with Low W/C-Ratio. Proceedings: Concrete in the Service of Mankind. - Concrete Repair, Rehabilitation and Protection. pp303-312, Dundee, UK, 1996.

A disadvantage of high performance concrete and a simple way to avoid it



Johan Alexanderson
Dr Techn
STRÅ Development AB
Emblavägen 4
182 63 DJURSHOLM

ABSTRACT

High performance concrete is excellent in reducing drying time but needs a levelling compound without Portland cement in order to protect the adhesive and the flooring from degradation.

Key words: High performance concrete, levelling compounds, alkaline attack, emissions, indoor air.

1 INTRODUCTION

It is a well known fact that many adhesives and floorings are sensitive to moist, alkaline conditions. Therefore, it is necessary to let concrete dry out to a certain extent before flooring is applied. However, the drying time can be quite considerable, especially when you have thick constructions or when you have drying out only in one direction, as is the case with remaining steel shuttering.

Therefore, it has been suggested that the use of high performance concrete with low water-cement ratio could be a way out of this dilemma. Then, the drying can mainly be achieved internally by chemical bonding of the water and you do not have to depend on the slow diffusion process of external drying. In the following, it will be shown that this can be an excellent solution, but only under certain conditions.

2 THE NATURE OF THE PROBLEM

What happens when flooring is glued on a moist concrete? Most adhesives are based on copolymer acrylates and they are sensitive to hydrolysis, so the first problem that happens, if the moisture level is high enough, is that the acrylates start degrading. Depending on the composition of the polymer, the degradation results in emission of volatile organic compounds (VOC:s), mainly 1-butanol and 2-ethylhexanol, which of course is negative to the indoor air.

Figure 1 shows such a mechanism for a concrete with water-cement ratio 0.77 (1). The figure describes the situation about 2.5 years after the PVC flooring (1.5 mm, homogenous) was glued with a water-based acrylic adhesive. The tests were performed with different drying times of the concrete, resulting in different moisture levels, which were tested with an RH-meter directly under the PVC at the time when the emission tests were done. The latter were done by The Swedish National Testing and Research Institute with the FLEC-method (2). Figure 1 shows very clearly that there is a critical RH, in this case of about 87%, over which the degradation increases rapidly. It should be noticed that while the 1-butanol is considered to come only from the adhesive, the 2-ethylhexanol can come both from the adhesive and from the PVC, viz. from the plasticizer - the most common one being dioctylsebacate. Similar results have been obtained by other researchers e.g. Wengholt-Johnsson (3).

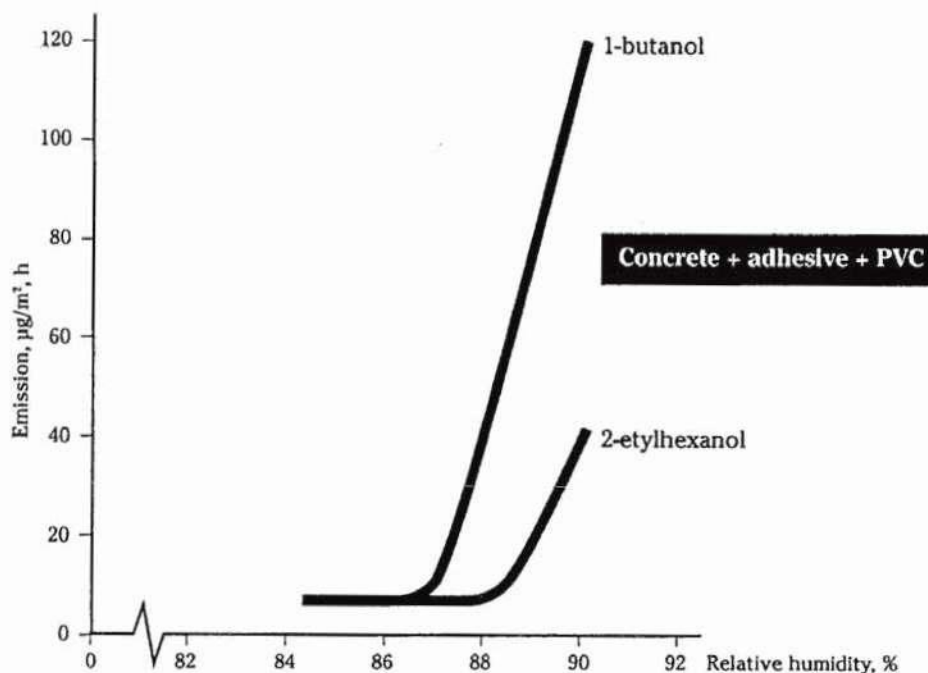

Figure 1: Emissions after 2.5 years when a PVC-flooring is glued with an acrylic adhesive on concrete ($w/c = 0.77$) with different moisture levels (1).

3 EFFECT OF WATER- CEMENT RATIO

One way of reducing the moisture level without excessive increase in drying times, is to reduce the water-cement ratio. Tests were done (4) with a standard concrete with w/c 0.5. This concrete is the same that is used when testing cement according to the European standard EN-196, i.e. one part cement and three parts of standard sand. Samples which were 100 mm thick were dried out in one direction for 14 days only, and then different floorings were applied.

The surface of the concrete was therefore dry when the floorings were applied, but then of course the moisture level under the flooring rose due to redistribution of the moisture. In the case of floorings with high resistance to water vapour (PVC) the relative humidity rose to about 86% and then dropped to about 83% until the time of measuring of the emissions, which was done after half a year. In the case of a more water vapour permeable flooring, such as linoleum, the RH at the time of measurement was somewhat lower, about 80%. So, by lowering the water-cement ratio to 0.5, an RH of about 85% could be reached by only 14 days one-sided drying of 100 mm concrete. For the concrete in Figure 1 with w/c = 0.77, it took 3-5 months to reach this moisture level. However, the emission tests did not show corresponding positive results. The emissions of butanol are shown in Figure 2 for the different combinations of adhesives and flooring. The first combination (PVC 1 and adhesive 1) is the same as in Figure 1.

FLEC - testing after 0,5 year

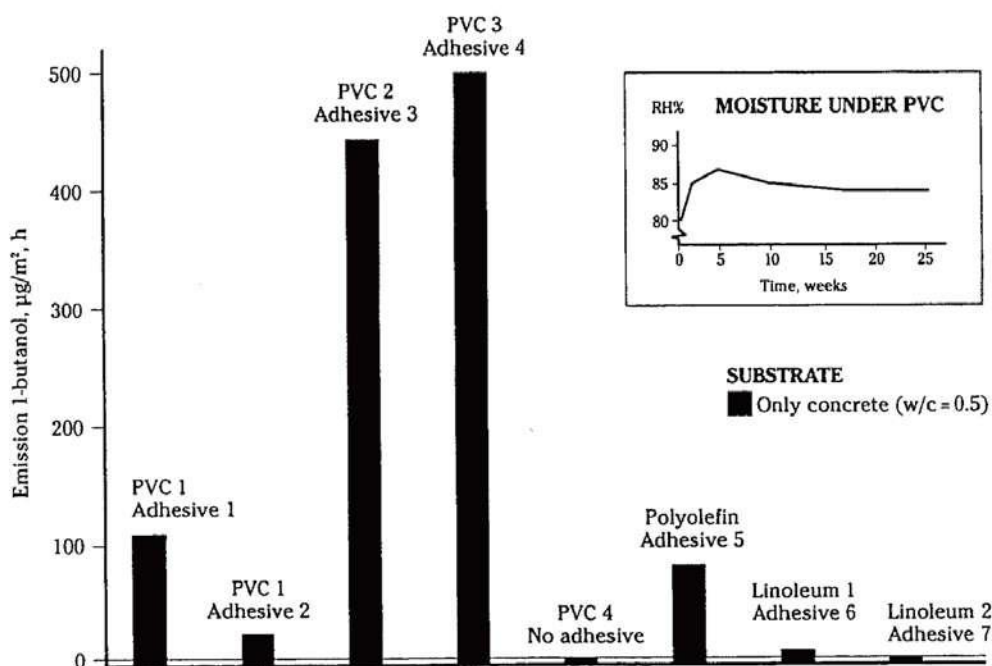

Figure 2: Emissions after half a year from different combinations of adhesives and floorings on a standard concrete (w/c = 0.5). The moisture under the PVC is shown separately (4).

From Figure 2, it can be seen that only when there was no adhesive and when the flooring was linoleum, the degradation was low. Additional test with PVC 1 and adhesive 1 showed low degradation, when the drying was extended to 42 days, resulting in an RH of 81% at the time of measurement. Therefore, the positive results for linoleum could be an effect of the lower moisture content (80%), but other factors can also have been of importance.

So, in spite of the positive effect on drying caused by the lowering of the water cement ratio, no positive effect on emission is achieved. In another test series (5), the water cement ratio was lowered even further to 0.35, resulting in an RH of 70% under the flooring after half a year, when the drying before the application of the flooring was only 7 days. But again, this does not help with regard to the emissions, see Figure 3. In this case, the measurements have been carried out during a prolonged time period, and it can be seen that the emissions change character over time. First, the butanol from the degradation of the adhesive is dominating but later the emission of 2-ethylhexanol is increasing, probably from the plasticizer in the PVC.

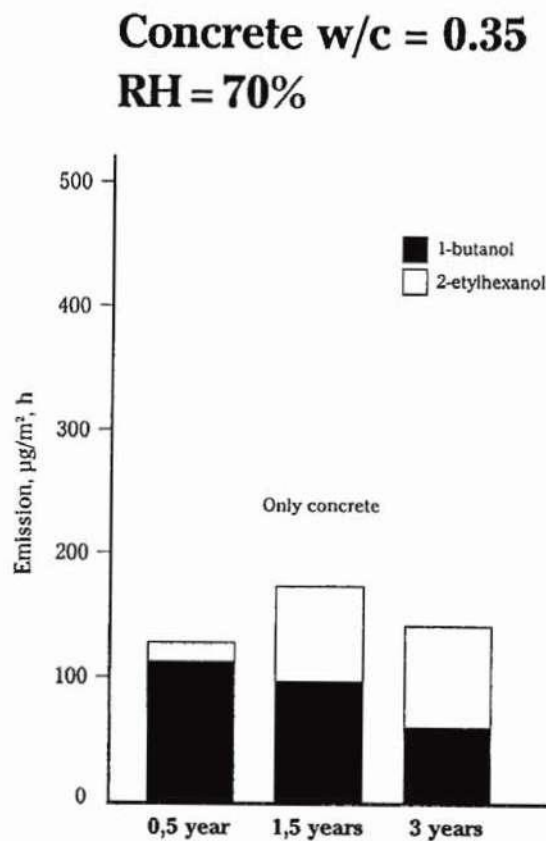

Figure 3: Emissions after different times when a PVC-flooring is glued on a high performance concrete (w/c = 0.35) (5).

In conclusion, by lowering the water-cement ratio, you certainly solve the problem of long drying times - the high performance concrete is really self-drying. But unfortunately, it seems as the critical relative humidity is lowered at the same time. So what you gain in drying you lose in critical RH.

The reason for this disadvantage of high performance concrete is not fully clear. One reason could be that the higher cement content causes higher alkalinity. Another reason could be that the low water cement ratio leads to such a dense concrete that the water in the adhesive cannot be transported quickly enough down into the concrete, but causes a high humidity locally under the flooring long enough to cause degradation (6). Anyhow, it is clear that a high performance concrete cannot itself solve the problem of degradation of adhesive and flooring.

4 A SIMPLE WAY TO AVOID THE PROBLEM

The root of the problem with degradation of adhesives and flooring is alkaline attack and the logical solution to the problem is to make the substrate to which you glue your flooring less aggressive. The alkalinity of concrete comes from the portland cement. Calcium aluminate cement does not form calciumhydroxide and has far lower content of potassium and sodium than portland cement, and is therefore much less alkaline. However, it is not practical to use calcium aluminate cement instead of portland cement in ordinary concrete, mainly because of the higher costs. But you can well use calcium aluminate cement in a thin levelling layer, which often is needed anyway because of the unevenness normally encountered in cast-in-situ concrete. And for precast hollow core slabs, a levelling layer is always necessary.

In Figure 4, results are shown when a levelling compound (STRÅ Universal) based on calcium aluminate cement without any content of portland cement is used. The figure shows the effect of a 5 mm layer as compared to gluing directly on to the standard concrete, previously shown in Figure 2 (4).

FLEC - testing after 0,5 year

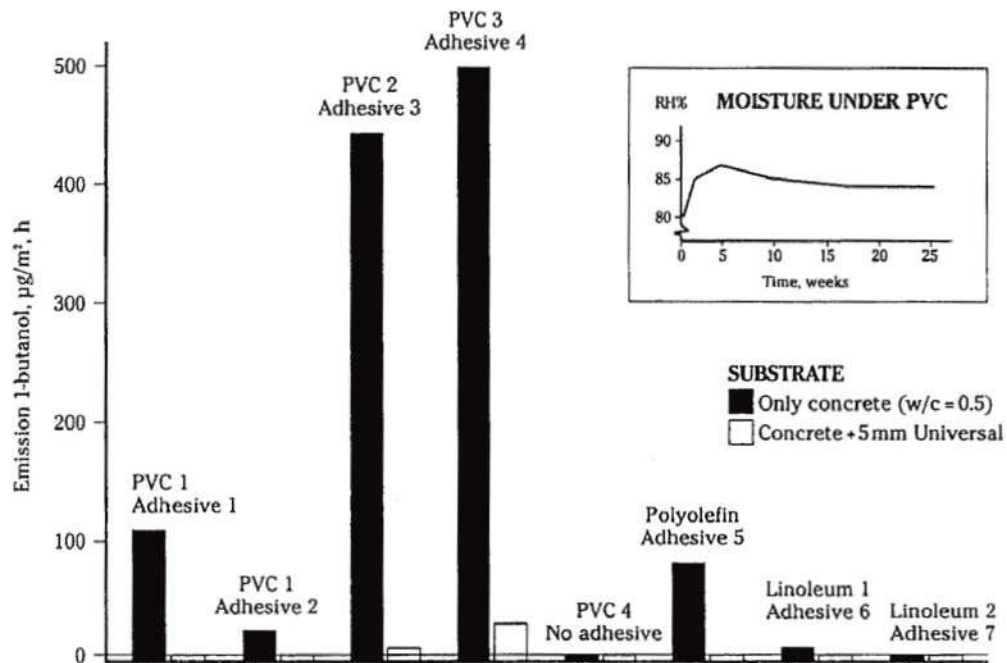

Figure 4: Effect of 5 mm levelling compound without Portland cement (STRÅ Universal) on the emissions from different combinations of adhesives and floorings (compare Figure 2) (4).

There is a dramatic decrease in emissions by the use of the levelling compound. In this case the measurement was done half a year after the application of the flooring. Of course one can question whether this effect is lasting over a longer period. In the investigation shown in Figure 1, a similar comparison was made. In that case, no emissions from degradation could be measured after 2.5 years when the levelling compound was 10 mm thick (1).

Also with the high performance concrete of Figure 3, the same comparison was made over a period of three years, see Figure 5.

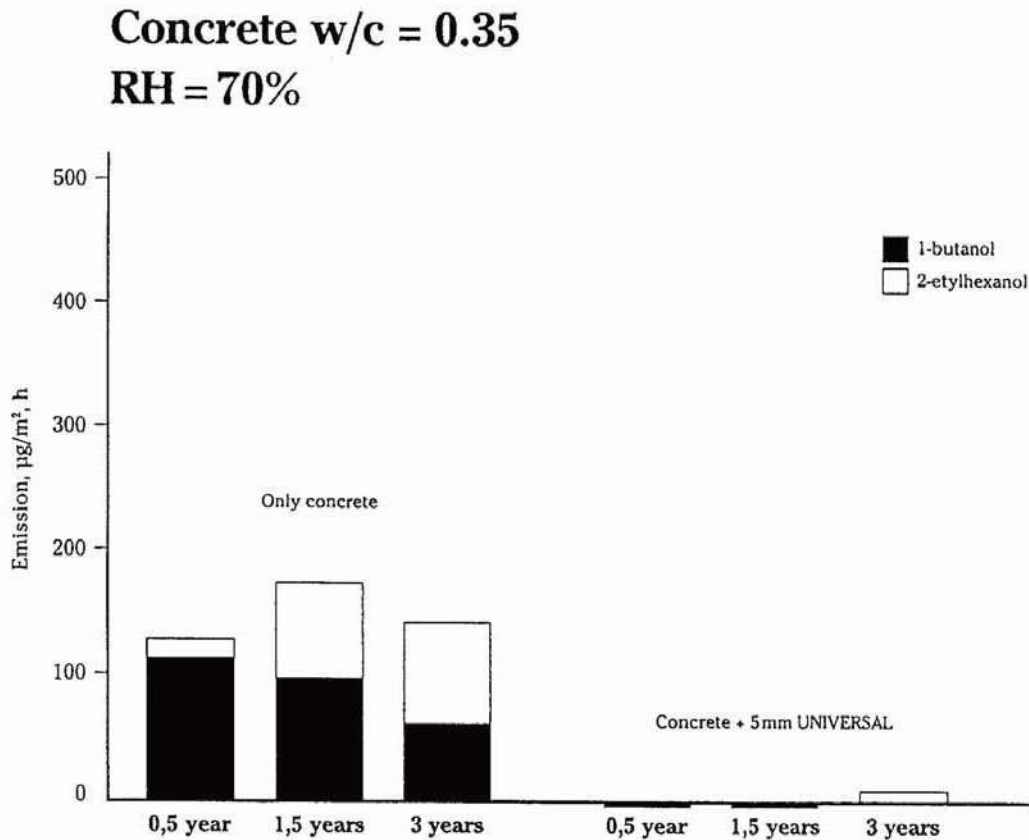

Figure 5: Effect of 5 mm levelling compound without Portland cement (STRÅ Universal) on the emissions from PVC glued on high performance concrete (compare Figure 3).

In this investigation one set of experiments was also done with the high performance concrete water-cured for one month and then dried for one week before the application of the flooring, see Figure 6.

**Concrete w/c = 0.35, water cured
RH = 84%**

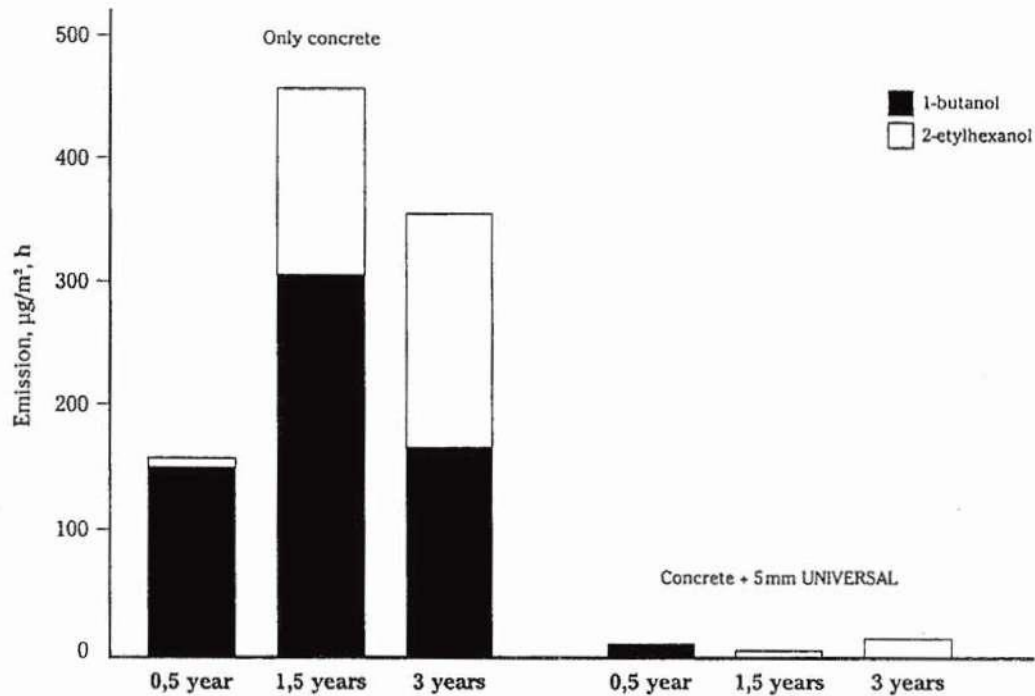

Figure 6: Effect of 5 mm levelling compound without Portland cement (STRÅ Universal) on the emissions from PVC glued on water cured high performance concrete (compare Figure 5).

From both these figures, it is apparent that the levelling layer without portland cement provides a very good protection against degradation of the adhesive and the flooring, both in the short and in the long run (5). This has also been confirmed in field tests (7) (8).

5 CONCLUSION

High performance concrete is a very effective way to shorten the drying times and reach low relative humidities, but in spite of that, degradation of adhesives and flooring occur, resulting in volatile organic compounds which are negative to the indoor air. The problem can easily be solved by using a levelling compound without portland cement but based on calcium aluminate cement. Through its low alkalinity, a protection for the adhesive and the flooring is obtained both in the short and the long run. Such a compound has been used successfully in Sweden for ten years. By a combination of high performance concrete and a levelling compound without portland cement, drying times can be reduced to an absolute minimum.

LITERATURE

- (1) Alexanderson, J., Långtidsinverkan av fukt på limmade golvbeläggningar med olika alkalitet. AMA-Nytt 2/94.
- (2) Wolkoff, P.et.al.- Field and Laboratory Emission Cell-FLEC. Proc. Healthy Buildings, p 160-165, Washington D.C. 1991.
- (3) Wengholt-Johnsson, H., Kemisk emission från golvsystem - effekt av olika betongkvalitet och fuktbelastning. Inst för byggnadsmaterial, CTH, 1995.
- (4) Alexanderson, J., Alkalisk nedbrytning i golv. Golv till Tak 5/95.
- (5) Alexanderson, J., Avjämningsmassa som alkalispärr. AMA-Nytt 2/95.
- (6) Fritsche, M., Sjöberg, A., & Wengholt-Johnsson, H. Golvlimmet påverkar emissionen från golvsystem. Betong 1/97.
- (7) Rosell, L., Emissionsmätningar 1996-06-17 -- 1997-06-18 i Kv Gädråret, Umeå. SP Rapport 96 K2 1471.
- (8) Hägglund, L., Rittfeldt, L & Lundvall, Å: Resultat från emissionsmätningar med FLEC i Kv Gädråret i Umeå, 1997-02-27 -- 1997-03-04. FOA Reg nr 97-1533/U.

EARLY AGE THERMAL CRACK CONTROL - INDUSTRIAL BENEFITS OF NEW TECHNOLOGY?



Stig Bernander
Adjunct Professor
Luleå University of Technology
971 87 Luleå



Mats Emborg
PhD. Assoc Professor
Luleå University of Technology and
Betongindustri AB
Box 473 12
100 74 Stockholm

ABSTRACT

Case studies of recent building project show that enormous cost savings are possible using advanced technique for crack risk estimations as will be developed in the Brite Euram project "Improved Production of Advanced Concrete Structures" (IPACS).

Key words: Thermal cracking, Hydration heat, Restraint, Mechanical behaviour, Crack arresting measures, Cost savings

1 INTRODUCTION

Are there any industrial objectives of integrating and extending our knowledge about early age thermal crack prediction in engineering practice and of developing new engineering tools for crack control?

- Yes! In some recent building projects where various more accurate temperature and stress related criteria for crack control have been used it has been clearly demonstrated that the industrial and social benefits of early age crack control are important. In the proposal for the Brite-Euram project named "Improved Production of Advanced Concrete Structures" (IPACS, 1996), an estimate of the costs for crack control has been extrapolated so as related to concrete construction in all of Europe. Thus, it is shown that enormous cost savings are possible by using advanced techniques for crack risk estimations.

2 CURING CONDITIONS, CRACKING AND LIFE TIME

Within the European Community many billions of ECU are invested in infrastructural concrete projects such as dams, reactor enclosures, marine structures, locks, bridges and tunnels. Many of these are located in harsh environments. Increase of service life time, mitigating of initial malfunction (e. g. lacking tightness) and reduction of maintenance and repair costs would result in enormous cost savings. Experience shows that the quality and life time of concrete structures largely depend on the curing conditions in the concrete's early life, as inadequate curing may lead to malfunction and cracking. A major source of cracking is the proneness of the hardening concrete to crack because of restrained volume change related to hydration temperatures and shrinkage phenomena.

3 PRESENT PRACTICE

Still, current methods to prevent early-age cracking are for the most part exclusively based on temperature difference criteria and do not consider many of other crucial influencing factors. Many future proprietors of infrastructures tend to impose more and more rigorous and costly specifications in respect of allowable hydration temperature differences.

The temperature-related criteria are based on the idea of a strong correlation between temperatures on one hand and thermal stresses on the other. The general agreement today is that this presumed correlation is very weak and does not constitute a reliable criterion for rational decision making. This is due to the fact that important parameters such as restraint, mechanical properties, non-uniform maturity and shrinkage are not considered in a such temperature based crack criteria.

A major problem is that, at present, there is no general acceptance of the new crack risk approaches based on stress simulations, among users, bodies for development of buildings and infrastructures and normative authorities. An exception to this tendency is the Swedish Road Administration which has adopted new thermal stress related criteria in the Swedish Code for Bridge Construction, Bro 94, Emborg et al (1997).

4 NEW TECHNIQUE

The objectives of the Brite-Euram project IPACS are to address the shortcomings of present state-of-the-art, e. g. existing computer programs of "second generation", and to provide new engineering tools of "third generation" which consider newly acquired knowledge, see IPACS (1996). This is effectuated by research on basic material

parameters and modelling thereof, by modelling appropriate structural behaviour and by establishing user-friendly computer assisted technology for advanced crack predictions.

This new technology will have decisive impact on all the costs in a project that are related to crack prevention measures.

5 COSTS SAVINGS BY USING ADVANCED STRESS RELATED CRITERIA FOR CRACK CONTROL

Costs for crack control in terms of costs per m³ of concrete structures (including reinforcement forms etc.) have been estimated in some recent major infrastructural projects, see Table 1.

The average cost, using temperature related criteria, thus amounts to some 5 to 7 % of the total cost of such concrete structures. This cost must not be confused with the total project cost that may include a number of other sources of expenditure. Another value is 230 to 330 SEK per m³ of the total volume of reinforced concrete.

Further, it can be observed from Table 1 that costs are reduced markedly if a stress related criterion is adopted.

Table 1. Costs related to crack control in some major projects, IPACS (1996)

Project	Costs of crack prevention measures		Criteria for crack control
	SEK per m ³ concrete structures	relative costs of concrete structures	
1987-90 Helsingborg tunnel (contract no 1)	160	3.8%	Stress related*
1991-93 Storebealt West Bridge	140	3.5%	Temperature related [#]
1994 Höga Kusten (Suspension Bridge)	100	2.5%	Stress related*
1995- Öresund- High Bridge Low Bridge Tunnel	285	6.4%	Temperature related
	301	6.7%	Temperature related
	280	6.2%	Temperature related
Dutch tunnels		5 - 7 %	Temperature related

*) Stress simulations were largely used in estimations of crack risks

#) Stress related crack risk estimations was in part unsolicitedly applied by the contractor, thus reducing costs

Case records involving applications of stress simulations in hardening concrete have shown that early age temperature cracking can be eliminated almost completely. If the probability of attaining the target crack risk (e. g. providing crack free concrete) using advanced analyses is set to 100 %, the corresponding probability using conventional temperature criteria will range randomly between 0 and about 90 %, say on average 50 %. On account of the complexity of the issue, an exact figure cannot be given.

However, a reasonable assessment is thus that the cost efficiency of crack prevention measures is increased from a mean value of 50 % to \approx 100 %. The average cost saving applying an advanced crack prevention system can thus estimated at 50 % of the figures in Table 1, see Table 2.

Table 2. Potential cost saving in some projects using advanced crack prevention system

Project	Volume of concrete structures m ³	Total mean crack prevention cost SEK/m ³	Saving (50 % of total cost)	
			SEK/m ³	MSEK
Helsingborg tunnel tot.	43 000	380	190	820
Contract no 2	21 000	600	440*	920
Storebaelt West Bridge	500 000	140	70	35
Öresund				
High Bridge	52 000	286	143	7.4
Low Bridge	154 000	301	150	23
Tunnel	630 000	280	140	88

*) This figure constitutes the documented saving related to Contract no 2 by comparison with Contract no 1 according to Table 3. Note: figures for Contract no 2 include costs for repair

6 THE HELSINGBORG RAILWAY TUNNEL - TWO CONTRACTS WITH DIFFERENT SYSTEMS FOR CRACK CONTROL

The Helsingborg railway tunnel and railway station constitute typical sections of wall and roof elements which during hydration are subjected to restraints related both to different temperature within the wall (and the roof) and to the stiffness of an existing slab. In the evaluations of crack risk in such sections, various scenarios with regard to pouring of concrete must be studied such as different air and placing temperatures,

effects of rate of pouring the concrete, artificial heating of the slab, cooling of the concrete, effects of bending and translation.

For Contract no 1, a roughly 1000 m long railway tunnel, it was found in the pre-design phase that the risk of cracking was too high in nearly all pouring scenarios. Comprehensive stress analyses with the HETT and TEMPSTRE computer programs were performed in the late 1980s, see e. g. Emborg (1990). An effective way of reducing high tensile stresses proved to be to cool the hardening concrete by means of embedded cooling pipes placed in the lower part of the wall, see Fig 1a and 1b. Hydration temperatures on the building site were recorded, Fig 1c, and constituted a basis for renewed stress evaluations showing maximum tensile stress levels less than 0.6, in which case the risk of cracking was not deemed too high. The final experience of casting the tunnel section in Helsingborg using internal cooling was very positive as more than 2000 m tunnel walls were cast without any thermal cracking taking place.

Contract no 2, the underground railway station, was sponsored by another client who was content with crack risk prediction by the conventional temperature related approach. Instead, external linings of bentonite pads (floor slab) and bituthene membranes (roof and walls) were used.. However, severe cracking in the concrete occurred, fig 2a, and in spite of the bentonite and bituthene linings, grave water leakage into the tunnel took place. This resulted in expensive reparatory grouting and uglifying crack injection works, fig 2b.

Comparisons of costs related to Contract no 1 and no 2 are shown in Table 3. The potential saving of using the advanced stress related criteria for crack control in Contract no 2 would thus have been $600 - 160 \text{ SEK} = 440 \text{ SEK}$, i. e. about 9 % of the cost of the concrete structure. In total, the saving would have amounted to about 9 MSEK for Contract no 2.

Table 3. Costs related to cracking in the Helsingborg tunnel

	Contract no 1 (22 000 m ³ , no cracking)	Contract no 2 (21 000 m ³ , through cracking)
Crack prevention measures	160 SEK/m ³	80 SEK/m ³
Lining, wolclay		85
Lining, bituthene		160
Extra reinforcement		15
Repair, injection		200
Embellishment		20
Maintenance and pumping of leaking water		40
Total	160 SEK/m ³	600 SEK/m ³

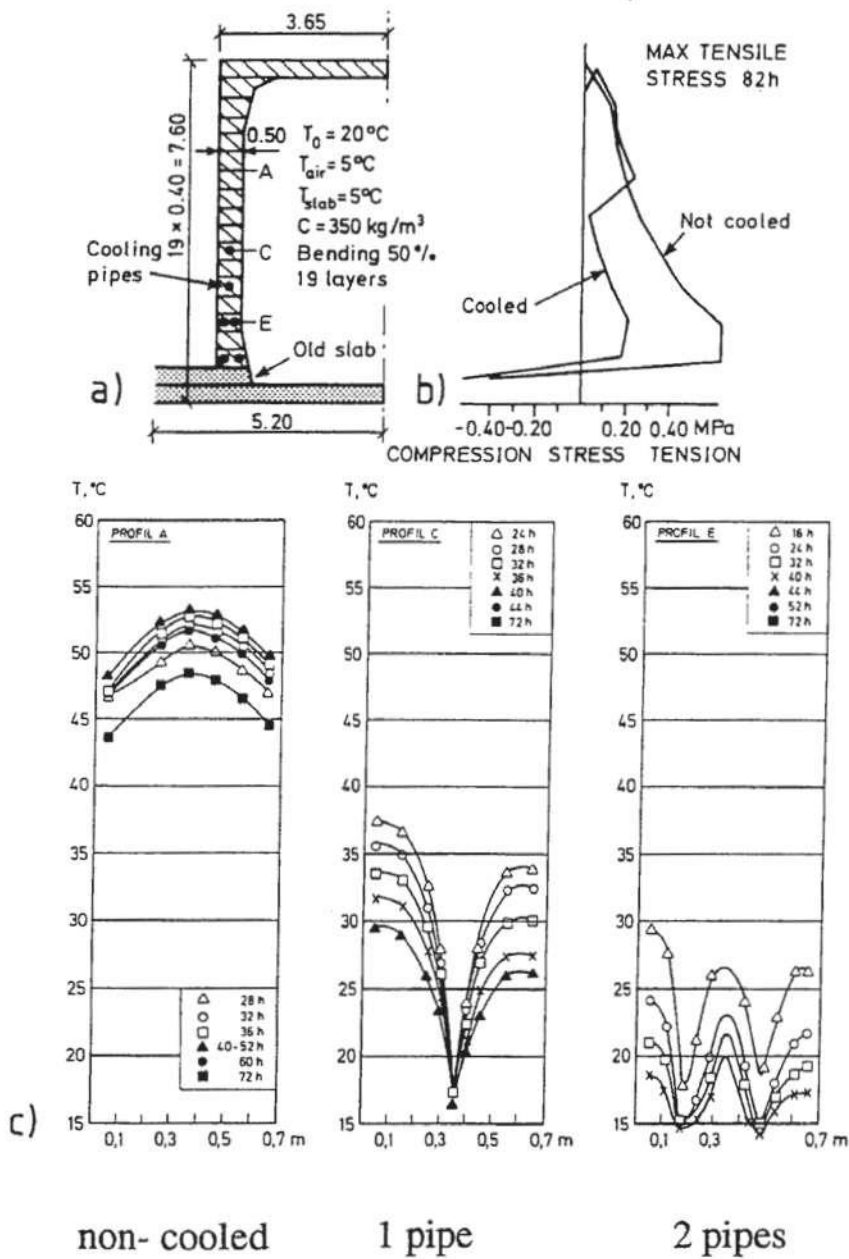

Fig 1. a) Box tunnel element cast on a cold slab
 b) Thermal stress analysis indicating the reduction of cracking risks for a cooled section compared to a non-cooled section
 c) Examples of recorded temperatures at three levels of the wall with different degrees of cooling, Emborg and Bernander (1994)

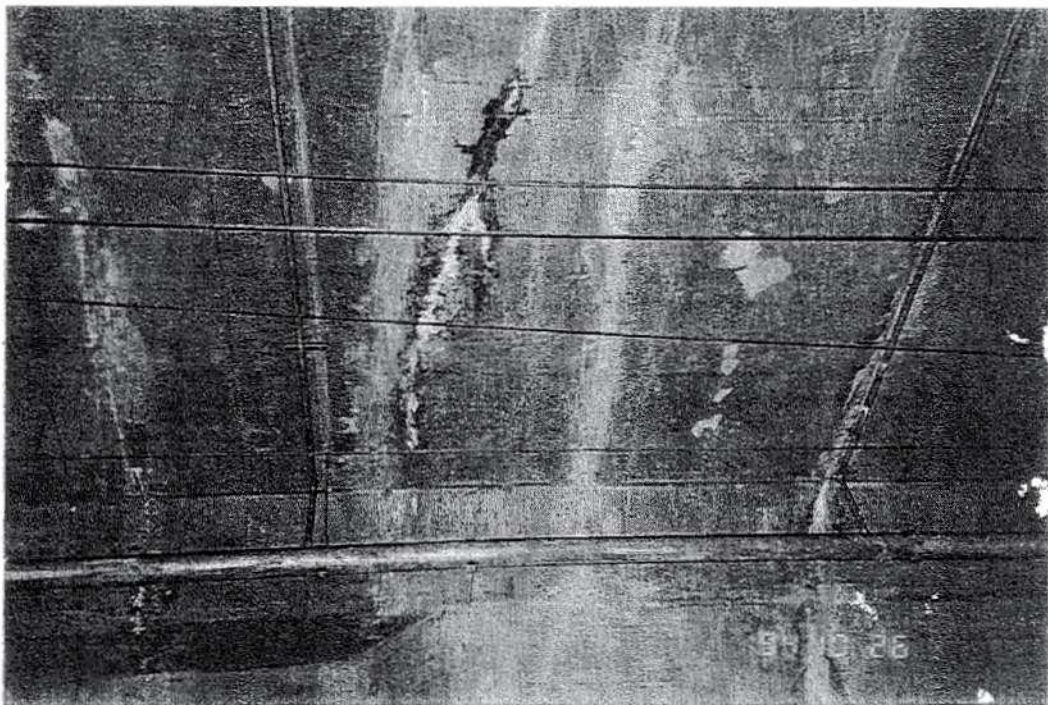
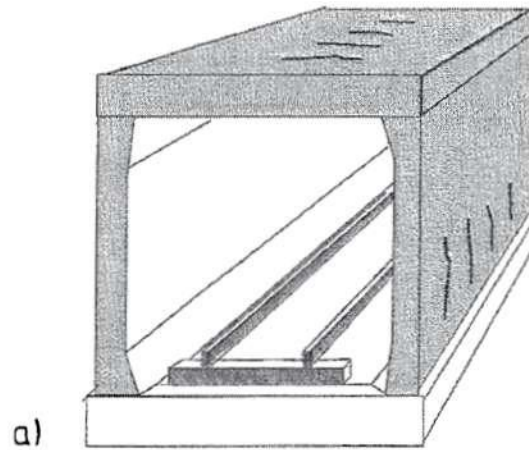

Fig 2. a) Typical cracking in walls and roof of the railway tunnel occurring in the cooling stage some weeks after casting.
b) Example of cracking in the roof of the Helsingborg railway station, Contract no 2. (photo Magnus Lindmark) (IPACS, 1996)

CONCLUSIONS

The given figures related cost savings may be applicable to other projects, thus, making and extrapolation for the total cost saving on an European scale. Assuming the total production volume of concrete where crack prevention is needed to be 15 Mm^3 /year and with a mean saving of 140 SEK/m^3 , cost savings in all of Europe may be estimated to be in the order of 2100 MSEK/year - an enormous figure!

The industrial and social benefits of the advanced stress related approach to thermal cracking as it was, for instance, successfully implemented on the Helsingborg tunnel, Contract no 1, are clearly manifested.

The aim of the IPACS project - namely to improve the state-of-the-art of concrete technology in this important discipline by making the new stress-related approach for early age crack control operational and generally accepted for application in Swedish and European building industry - is well justified.

REFERENCES

- Bernander S (1981). Temperature stresses in early age concrete. Rilem Int Symposium on Early Age Concrete, Paris 1981.
- Bernander s (1983). Regarding efficiency of internal cooling of fresh concrete, Nordisk Betong, nr 5, 1983
- Bernander S, Emborg M (1994) Avoidance of early age thermal cracking in concrete structures - predesign,, measures, follow-up, Prc from Rilem Int Symposium "Avoidance of Thermal Cracking in Concrete" Munich Oct 1994, 8 pp.
- Emborg M (1990) Thermal stresses in concrete structures at early ages. Doctoral tehsis 1989:73, Div of Struct Eng, Luleå Univ of Techn. 1990, 286 pp
- Emborg M, Bernander S (1994) Assessment of the risk of thermal cracking in hardening concrete. Journal of Struct. Eng (ASCE), Vol 120, No 10, Oct 1994, pp 2883-2912
- Emborg M, Bernander S, Ekerfors K, Groth P, Hedlund H (1997) Temperatursprickor i betongkonstruktioner. Beräkningsmetoder för hydratationsspänningar och diagram för några typfall, Div of Struct Eng, Luleå Univ of Techn, Technical report 1997.02T, 100 pp
- IPACS (1996). Improved Production of Advanced Concrete Structures, Description Brite-Euram Proposal and Supplement, Div of Struct Eng, Luleå Univ of Techn 1996.

ON TRANSMISSION of RESTRAINT via CONSTRUCTION JOINTS in CONCRETE STRUCTURES

By prof. Stig Bernander, Technical University of Luleå

1: Introduction

Many a concrete structure is damaged already in the process of coming into existence because of 'overloading' i.e. by being strained beyond any future loading effect that may otherwise occur in its service life. Early age cracking due to hydration volume change belongs to this category of deleterious loading effects which, if unattended, may jeopardize the functional capacity and shorten the life cycle of a structure. However, practical engineering has demonstrated that early age thermal cracking can be avoided or efficiently mitigated by careful planning and application of various measures in the design- and construction stages of a project. Often such measures can be implemented at low costs in relation to the total capitalized cost of a structure and should therefore always be considered in the production of concrete elements susceptible to early age cracking.

Recent research and development has greatly improved our engineering capacity to predict and control early age cracking in concrete construction.

However, one of the uncertainties associated with the consideration of stresses and cracking in this context is our *notorious lack* of knowledge about the restraints that are mutually imposed by different parts of a concrete structure which have been cast in different stages of construction.

This report, dealing with restraint, aspires to throw some light on this very important issue in concrete technology.

2: General

The fact that restraint between two adjoining concrete elements is a decisive factor when estimating the effects of imposed stresses due to temperature and shrinkage rests in the nature of the problem - an understanding that is by no means new. An indication of this is e.g. figure 1, which was published by Copeland 1957.

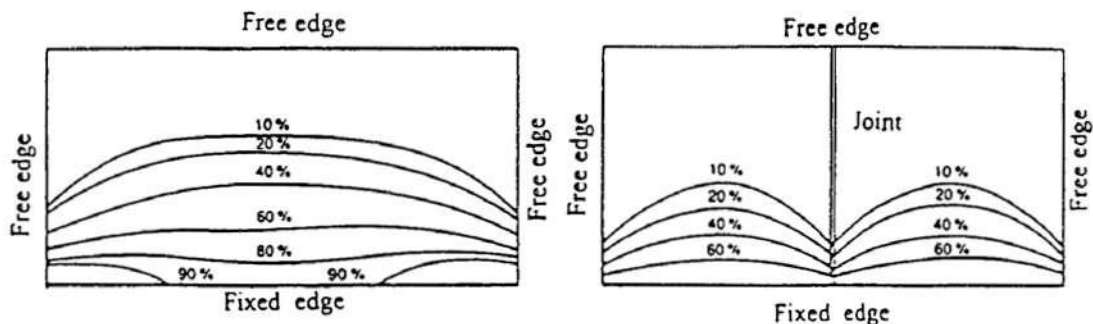

Figure 1. Walls subjected to temperature reduction. Numbers signify percentage reduction of volume change because of inhibited movement, thus constituting a measure of the restraint in different parts of the walls. (Copeland 1957).

It may therefore seem rather odd that so little R & D has been dedicated to the important task of quantifying restraint between different parts of concrete structures. Because, *even to this day*, early age cracking in advanced concrete infrastructures is often based solely on temperature differentials i.e. without actually considering the effects of restraint.

The degree of restraint is often defined as a percentage of 'full restraint' - i.e. 100 % signifying no deformation in the restraining structure. Complete freedom of movement is thus in this context attributed a value of 0 %.

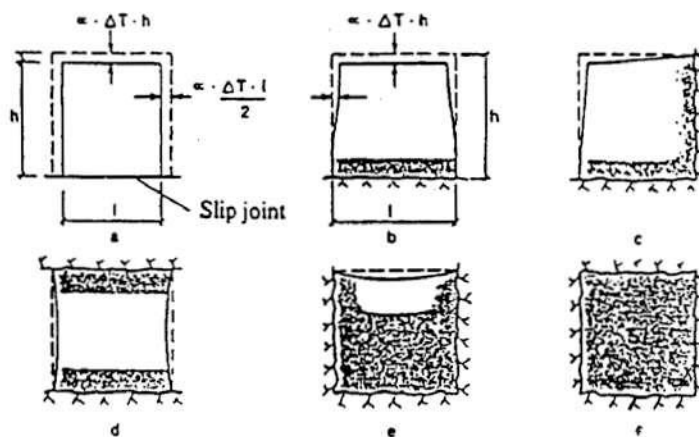

Figure 2. Examples of different types of restraint. Shaded parts indicate areas subjected to considerable restraint, implying potential proneness to through cracking. (Bernander, 1980).

3: Construction measures relevant to restraint

Restraint depends primarily on the configuration of the restraining structures and the freedom of movement that they will allow. Figure 2 indicates qualitatively various types of restraint that may result from alternative pouring sequences.

The degree of restraint varies spatially within a cast section and depends on many factors such as the dimensions and the geometry of a section, pouring sequences in construction, stiffness of the restraining structures, length and nature of construction joints, freedom of movement of the integral structure e.g. in bending etc. In order to model and quantify restraint in the cooling stage of hydration it is usually sufficient to resort to the normal computation procedures in structural mechanics analysis, thus evaluating current restraint from one case to another.

The case record shown in figure 3 may serve as an illustrative example of how pouring sequences may affect the degree of restraint as well as the measures required to cope with varying restraint.

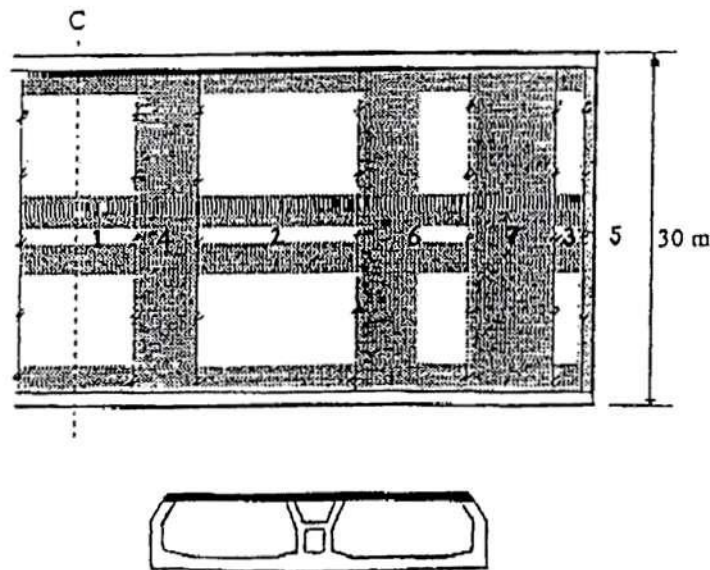

Figure 3 Pouring sequence for the roof slab of the Tingstad tunnel (1964-66).

Shaded parts, being areas of high restraint, were water-cooled by means of embedded piping. Estimation of crack risk was systematically based on strain criteria according to what is nowadays termed as the 'manual calculation method' by which e.g. early age plastic behaviour is considered. (Cf the Design Handbook for

High

Performance Concrete, 1997). The cooling effect was adapted to a target crack risk, to the degree of restraint and to the seasonal variations of the temperatures of fresh concrete and cooling water. (Bernander, 1973, 1980).

4: Restraint imposed via construction joints

More often than not restraining action on a poured section is transmitted by shear and normal stresses across construction joints - a condition that, as we shall see, deserves special consideration. Figure 4a below shows a case similar to that in figure 1 where the magnitude and distribution of principal stresses in a wall - also subjected to an evenly distributed reduction of temperature - are shown. Full adhesion in the joint is assumed.

As can be seen in the diagram the principal stresses are, not unexpectedly, highest in the corner portion at the extreme end of the construction joint (point A). However, in practice cracks generally tend to occur in the central parts of such walls as indicated in figure 4 b. The *inevitable conclusion* from this apparently remarkable discrepancy between theory and practice is that full adhesion in the joint *cannot* be present, evidently due to a 'slip' failure taking place - starting from the far end (A) of the joint.

Figure 5 shows a result from an investigation illustrating the high shear stresses and the typical *peak tensile stresses* at the extreme end of a construction joint - in this case as a result of a temperature reduction of 10°C. The combined effect of high shear stresses and the

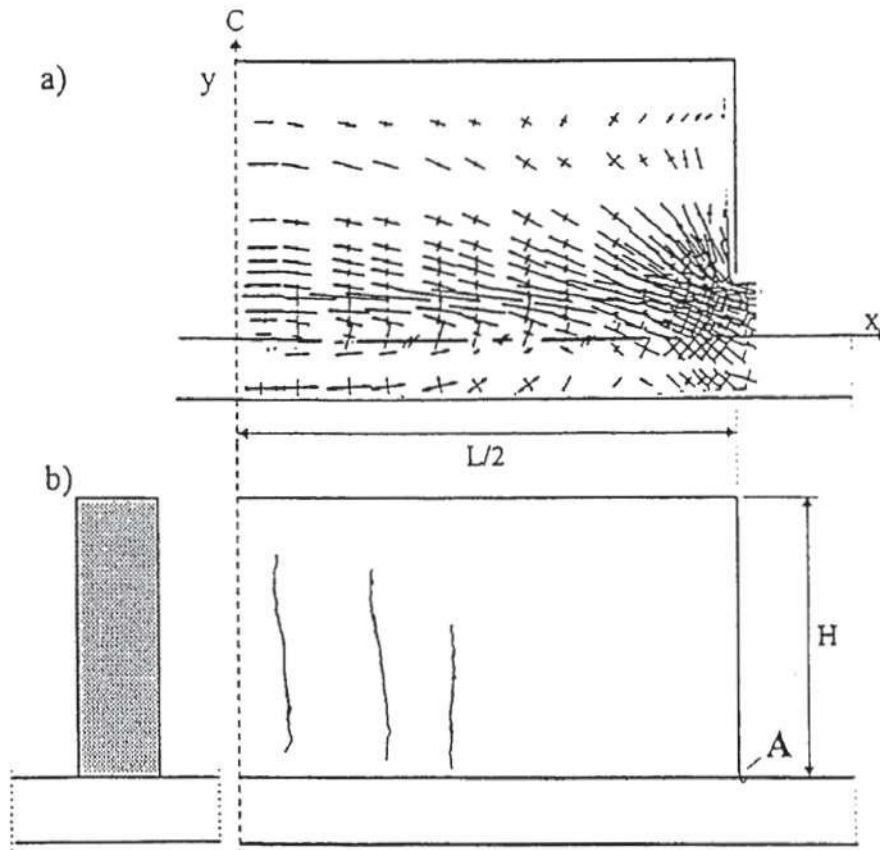

Figure 4 The figures show a) the distribution and relative magnitude of principal stresses in a wall subjected to a temperature reduction assuming full adhesion between the joint interfaces. b) Through cracks as they generally appear in reality in a corresponding scenario.

concentrated tensions perpendicular to the joint constitute a very difficult state of stress - inexorably producing at least a local failure at point A. In fact, a failure analysis at this location demonstrated, that even if the cohesion strength of the concrete were assumed not to be affected by the innate weakness of construction joints, a local failure would occur, resulting in a slip between new and older concrete. Further, even in a joint with through reinforcement, this failure is likely to propagate along the joint as a progressive 'shear band' failure until the shear forces in the joint balance the total tension force (N_x) at the mid-section as indicated in figure 5 below. The associated slip entails a reduction of the restraint exercised by the joint. In fact, the only way in the example to avert this progressive failure would have been to eliminate the splitting action of the 'end peak tension' by applying sufficient concentrated transverse reinforcement at the corners (A).

Hence, the restraining action of a construction joint will depend on its *length*, the amount of *through reinforcement* and the *friction characteristics* of the joint interfaces.

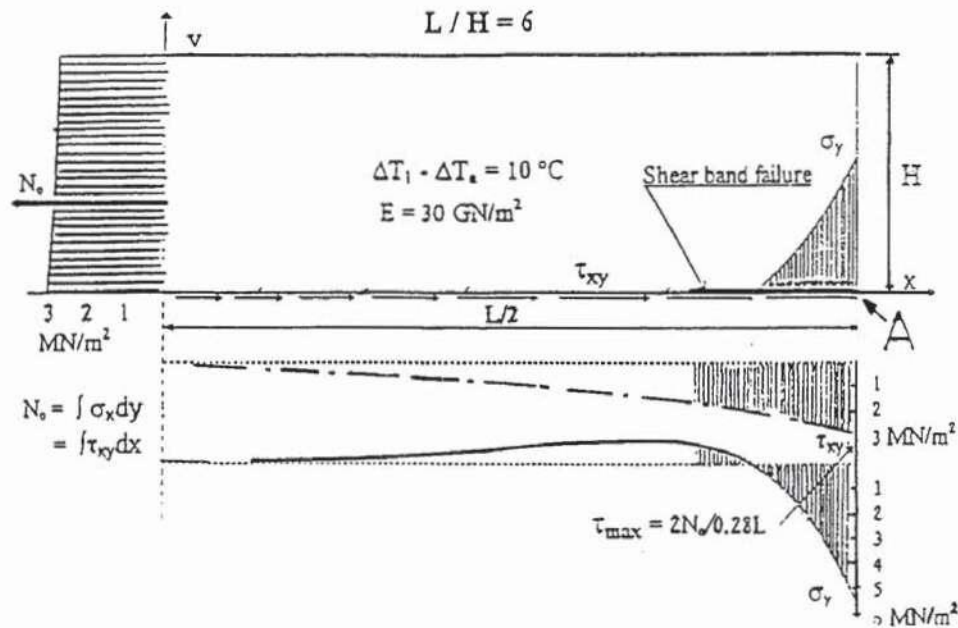

Figure 5 Results from a study of the behaviour of a construction joint between a wall and an underlying stiff concrete slab in respect of its restraining action. Stresses have been calculated assuming *full adhesion* in the joint interface. The important shear stresses and the high peak tensile normal stresses at point A will, however, in many cases initiate a progressive shear band failure as indicated in the figure. The associated slip between wall and slab will entail a reduction of the restraint imposed on the wall. Hence, this restraint will depend on the length of the joint, the amount of reinforcement, friction in the joint interface and the stiffness of the sub-grade. (Bernander, April 1994, not previously publ.).

The above mentioned study thus indicates that through cracks occurring in the central part of a wall (as shown in figure 4b) *must be preceded by*, at least, a *partial failure* with an associated slip along the joint. The compelling reason for this is that - *if this were not so* - cracking would predominantly take place in the vicinity of the far end of the joint at (A).

5: Conclusions - practical implications

The above considerations have far-reaching practical implications on design, construction and economy in respect of early age through cracking in concrete structures.

a) Firstly, it is evident that the slip in the joint between new and older concrete is bound to have a decisive effect on the restraining action to which the young concrete is subjected. If, for instance, the length L in the example shown in figure 5 is 10 meters, the total contraction

at each end of the wall, corresponding to the 10°C , will only be roughly 0.5 mm, implying e.g. that a minute slip in the joint at one end of only 0.25 mm would reduce the restraining effect by about 50 %.

b) Secondly, a *necessary prerequisite* of the formation of the centrally located cracks shown in figure 4b is that the construction joint must have *sufficient length* and/or *sufficient reinforcement* to mobilize enough shear to build up the tensional force (N_0) required to provoke tensile failure in the wall section. The *mobilizable shear forces* in the joint will thus depend on 'post-failure' friction, dowel action of reinforcement and resulting compression perpendicular to the joint. Such compression will ensue from the balancing of the lifting forces at the joint end by reinforcement, from dowel action of re-bars (minor effect) and as a result of deviations of the joint alignment from a straight line.

c) The described phenomenon of the accumulative build-up of the wall tension (σ_x) along the joint involves the relationships between the slip failure, through reinforcement, friction and joint length. It offers a *reasonable explanation* to the factual observation in practical engineering, that through cracks tend to occur when the lengths of construction joints exceed 8 to 10 meters. This is, namely, a circumstance that challenges theoretical prediction (when assuming full adhesion) according to which tensile strain and crack risk ought to be independent of size and scale effects.

d) A third rather odd implication is, that a poorly cleaned construction joint will be less prone to produce cracks in the newly poured section than a carefully treated one - a circumstance worth contemplating in connection with water-tight structures, where construction joints in any case are fitted with sealing profiles for tightness. Such a consideration could for instance be implemented by intentional elimination of the adhesion in the construction joint.

e) The structural scenarios shown in figures 1, 4 and 5 presume a stiff, *inflexible sub-base*. It should be noted that the stresses in the joint will be somewhat different if the wall is only partially restrained in bending due to flexibility of the sub-base or because of weak connection to the same.

f) The current common practice of assuming full adhesion in joints is, in many cases, evidently much too conservative - in particular for joints with moderate lengths ($L < 6 \text{ m}$), along stiff substructures and with insignificant reinforcement.

However, the *main conclusion* to be drawn from the reasoning above is that *extensive future research* in this field must be focused on modelling and quantification of the true restraining effect of construction joints..

In view of the fact that the degree of restraint constitutes a decisive prerequisite for the formation of stresses due to inhibited volume change, the issue dealt with in this article is of paramount technical and economical importance in concrete construction.

Zimbabwe, Mutare 97-09-15

Stig Bernander

INDUSTRIALISED SITE-CAST CONCRETE



Jan Byfors
Professor
NCC AB

ABSTRACT. This paper discuss increased efficiency and productivity in relation to site-cast concrete. Industrialised construction could be divided into several components such as, direct design into a 3D-model, efficient assembly places on building site and increased co-operation between contractor, sub-contractors, designer and suppliers. Parameters for industrialised site-cast concrete are optimisation of formwork, exchange of traditional reinforcement, mechanised handling systems and use of self compacting concrete. Industrialised site-cast concrete could reduce the manpower by 80% compared with traditional methods. Of particular interest for self compacting concrete, is the development of new admixtures which are now entering the concrete market.

Keywords: Industrialisation, production costs, site-cast concrete, self compacting concrete

INTRODUCTION

The building industry is facing great changes and demands and particularly three dominating forces are governing the development. These three forces are:

- environmental issues
- information technology
- increased efficiency or productivity

Here in this paper we will discuss increased efficiency and productivity in relation to site-cast concrete.

INDUSTRIALISED CONSTRUCTION

One main way to increase the efficiency is to achieve a more industrialised construction. This contain several components of which the most important are:

- Designing will change from a traditional drawing and calculation to a designing directly into a 3D-model. This designing will simultaneously include all relevant

partners as architects, engineers, material suppliers, contractor and sub-contractor. All these partners will communicate with the 3D-model which is a so called project data base. All relevant information will be stored in this data base and when needed one will receive information from data base. No drawings will be distributed, but the partner who at a certain situation need a drawing will require the drawing directly from the data base. All communications between the involved partners will be digital, thus different partners must not necessary be situated geographically close.

- The building-site will change from being a place of traditional craft work to become a place for assembly. A benchmarking towards the car-industry is here most relevant. For the building-site to convert into an assembly-site the building materials and products has to have an increased degree of pre-fabrication and also a significant higher level of tolerance. All manpower-work has to be reduced by using more and more mechanised and automated tools and equipment's. The amount of robots at building-sites will increase. And finally, by tradition construction always has been very sensitive to weather situation which has to be eliminated. The assembling at the building-site has to become more independent of the weather for example by using different types of mobile weather shields.
- 60 - 70% of the turn-over for a certain construction project is material and sub-contractors purchased. To achieve a more industrialised construction the co-operation between the contractor on one side and the suppliers and sub-contractors on the other has to improve. Also here experience from the car-industry can be applied on the construction industry. Traditional suppliers has to become partners with the contractor and not only for a single project but on a long-term basis, thus in co-operation perform development. Instead of selling building products it will be more and more a matter of supply of components suited for the assembly system used by the contractor. Further it will be necessary to leave today's situation of JIC - just-in-case- and to reach the level of JIT - just-in-time. Perhaps in the future we will see co-operation between suppliers and contractors where the supplier takes full responsibility for JIT by having complete information regarding schedules and achieved performance at the site.

IS THERE A FUTURE FOR SITE-CAST CONCRETE?

Will there be a future for site-cast concrete in a building industry becoming more industrialised? The answer is definitely no with a site-cast concrete of today's, but there are possible and promising developments occurring which will serve as a base for site-cast concrete of tomorrow, thus to achieve a *industrialised site-cast concrete*. Ways of achieving this will be presented here after, but before doing so it is of interest to study the cost for a site-cast concrete building frame. In the table such costs are presented based on data assembled from Swedish contractors.

Table 1. Cost for construction of site-cast concrete building frame based on data assembled from Swedish contractors.

	Labour costs	Material costs
Form	20%	12%
Reinforcement	8%	12%
Concrete	4%	27%
Others	15%	2%
Total	47%	53%

From the table it is seen that almost 50% of the total construction cost is cost for manpower, where the formwork is the main part. The item Others include very much the correcting work done at the building-site due to such as incomplete compaction, large pores in the surface, leakage of cement paste through joints in the form etc. In other words necessary manpower due to not doing "right from the beginning".

INDUSTRIALISED SITE-CAST CONCRETE

Which are, on the other hand, today's means of decreasing the amount of manpower for site-cast concrete, but still achieving the advantages of site-cast concrete due its monolitical structure. There are today several possibilities and we will here present some of the most important which together will result in much more industrialised site-cast concrete. These means are:

- Traditional forms are changed to non-removable forms such as filigran. These form will create a composite element where the form to large extent also serve as reinforcement in the finished structure. Thus most of the field reinforcement in slabs is included in the form.
- The main part of the reinforcement work for walls and slabs may be deleted by using steel-fibre reinforced concrete, FRC. Today's knowledge and experience regarding design and construction of with FRC is on such a level that FRC can be used in a reliable way.
- The handling of concrete is today already to a large extent mechanised by pumping the fresh concrete.
- Finally by using self compacting concrete, SCC, the manual compaction work can be eliminated, but in the same time an improved quality can be reached as defects due to compaction and occurrence of large surface pores will be deleted.

By applying these four technologies at the same time we will achieve industrialised site-cast concrete. Thus the vision is:

On a building-site non-removable forms are used. In these forms fibre reinforced self compacting concrete is poured by pumping and thus the concreting work is completed.

Conventional form	→	non-removable composite form
Reinforcement work	→	fibre reinforced concrete
Handling of fresh concrete	→	pumping
Compaction of concrete	→	self compacting concrete, SCC

Figure 1. Technologies for achieving industrialised site-cast concrete

The necessary manpower needed by industrialised site-cast concrete as described above should be possible reduce by 80%. If this is reached site-cast concrete definitely will have its place in an over all more industrialised future construction.

SELF COMPACTING CONCRETE

Of the four different technologies described above one is still under development and today not regarded as an established technology and that is SCC. Great resources are invested in developing SCC all over the world and particularly in Europe. The knowledge regarding workability and rheology of fresh concrete has during the last years reached such importance that we today can describe and modelling the behaviour of the fresh concrete particularly by using so called 2-points measuring. By such measuring it is possible to describe the fresh concrete resting in-place as well its mobility by using g and h-values. The g-value is a value describing the initial shear stress resistance and the h-value is a value for the viscosity. In the figure 2 different types of concrete are presented in g-h-diagram. As can be seen in the figure a SCC shall have a as low as possible g-value thus to be able to achieve mobility already due to small forces. A fairly large h-value is necessary however, thus to secure a stable and homogenous concrete. By using different types of filler, but most of all by using modern types of concrete admixtures it is possible to compose a SCC with self compacting properties robust for practical use. Of particular interest is the development occurring today regarding new admixtures of completely new types which are now entering the concrete market.

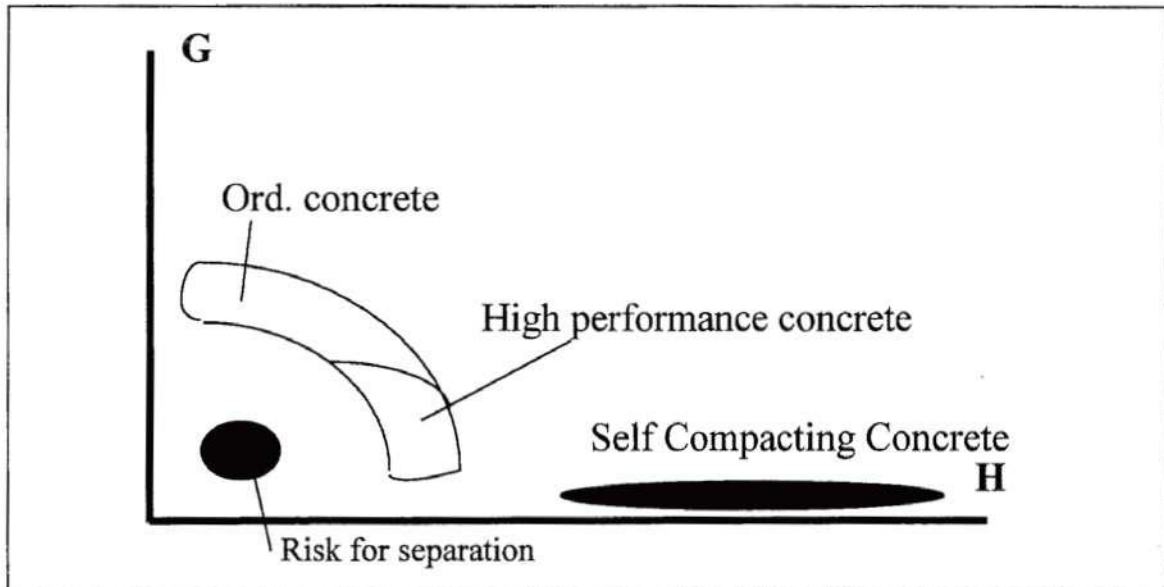

Figure 2. Rheology parameters for different types of concrete's.

MATERIAL AND STRUCTURAL TESTING AND MODELLING OF CONCRETE



Lennart Elfgren
Tekn Dr, Professor of Structural Engineering
Luleå University of Technology
SE-971 87 LULEÅ
SWEDEN

ABSTRACT

Integration of material and structural modelling of concrete is a new trend in the process to obtain better methods for assessing the life length of structures. Some examples regarding testing and subsequent modelling of crack width, ductility and strengthening of structures are described

Key words: Concrete, Material modelling, Structures, Ductility, Brittleness, Toughness, Fracture Mechanics, Cracking, Beams, High Performance Concrete.

1. INTRODUCTION

The need to assess and increase the durability of structures has given increased motivation to the integration of structural and material modelling. Examples of this trend can be seen in the CEB-FIP Model Code (1990) and will in the future also be incorporated in new versions of the European Codes as EC-2 (1991). In this paper some examples are given of work in this direction performed at Luleå University of Technology, LTU.

2. HIGH PERFORMANCE CONCRETE

A research and development program on High Performance Concrete (HPC) structures has been performed in Sweden during 1990-1997, see e.g. Fagerlund et al (1996). Material, Structural and Production issues have been studied and the interaction between material and structural modelling has become more and more obvious. The brittleness and ductility of high performance concrete structures are linked to the tensile strength and the tensile softening of the stress-deformation curve of the material. Studies are based on the fracture mechanics concepts introduced by Hillerborg et al (1976) and developed further in international co-operation, Elfgren (1989). Work on the ductility on HPC structures has been performed by Henrik Gabrielsson et al (1996, 1997). He has found that forces in a prestressed hollow-core slab can to a certain degree be redistributed also in a

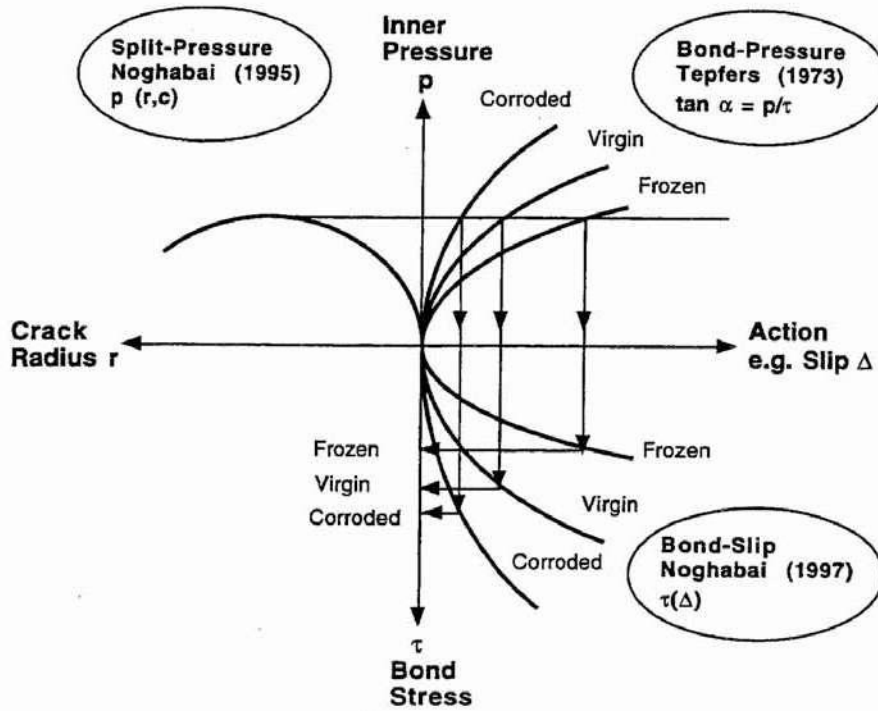

Figure 4.1 A model for assessing the influence of corrosion, frost and fire. See Noghabai (1995, 1996, 1997) for further discussion .

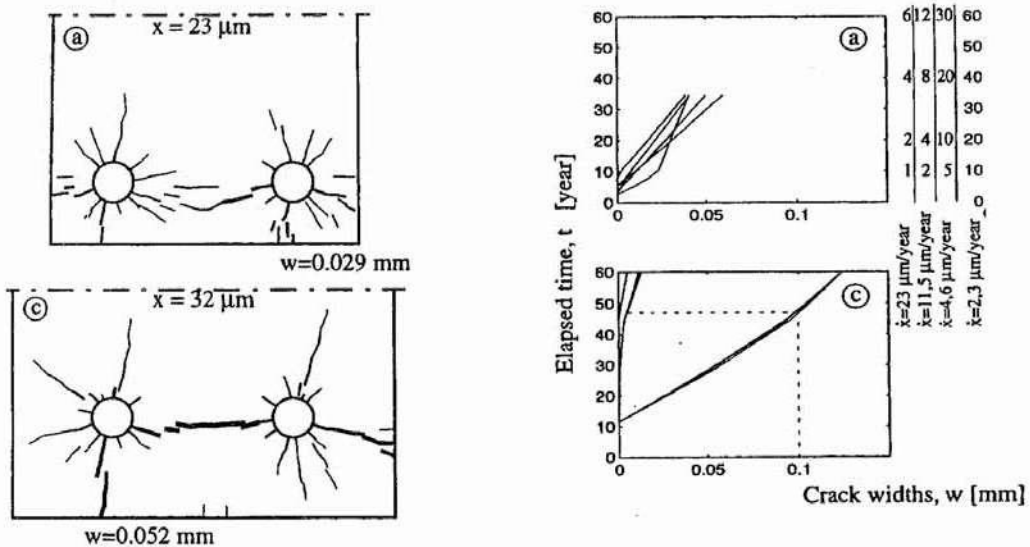

Figure 4.2. Calculated crack widths as function of time based on a corrosion model and an inner softening band finite element method. From Noghabai (1997)

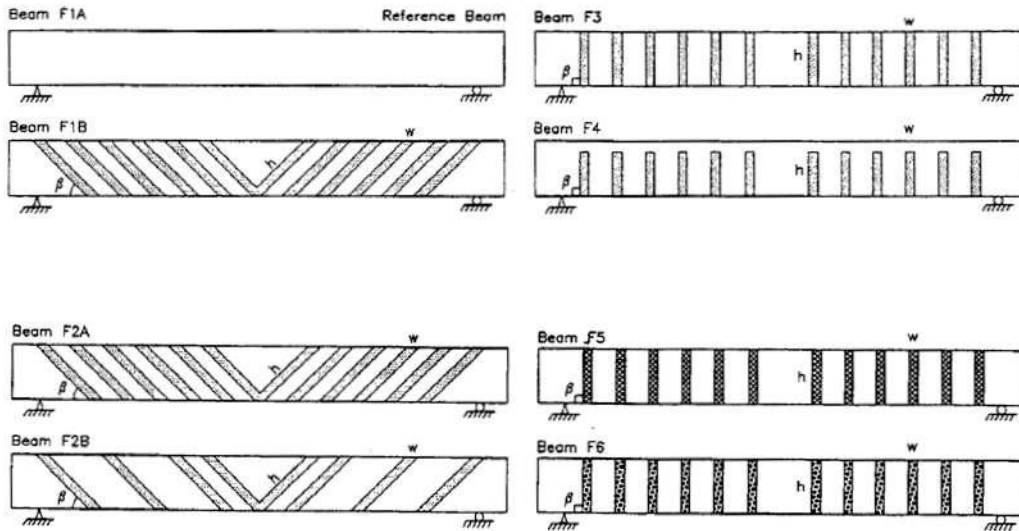

Figure 4.3. Beams strengthened in shear with externally bonded reinforcement From Täljsten (1995).

The inner softening band method has also been applied to model mixed mode and anchor bolt problems, Olofsson et al (1995), Ohlsson et al (1997).

Strengthening of concrete structures is one way to increase the life length. Tests by Björn Täljsten (1995) show that externally bonded reinforcement can be used to increase the shear capacity, see Figure 4.3.

5. CONCLUSIONS

Concrete is an efficient material which can be used in many structural applications with good economy and durability. Recent advances in modelling has made it possible to better predict the life length and the influence of various environmental loads. The interaction of material and structural modelling is here essential.

6. ACKNOWLEDGEMENT

The contributions from my colleagues in the National Swedish High Performance Concrete Program and at the Division of Structural Engineering at Luleå University of Technology are gratefully acknowledged. Funding from CEMENTA, ELKEM, EUROCONCRETE, NCC, SKANSKA, STRÄNGBETONG, the Swedish Council for Building Research (BFR), the Swedish National Board for Industrial and Technical Development (NUTEK) and the Swedish Contractors Development Fund (SBUF) is also gratefully acknowledged.

7. REFERENCES

- CEB-FIP Model Code (1990): Design Code, Comité Euro-International du Béton and Fédération International de la Précontrainte, Thomas Telford, London 1993, 437 pp (ISBN 0 7277 1696 4).
- Design Handbook (1997): High Performance Concrete Structures, Report K6:2B, Luleå University of Technology, Division of Structural Engineering, Draft 1997.
- EC-2 (1991): Eurocode 2: Design of concrete structures - Part 1: General rules and rules for buildings. European prestandard ENV 1992-1-1:1991, CEN (Comité Européen de Normalisation), Brussels, 1991, 253 pp.
- Elfgren, Lennart.(Editor): Fracture mechanics of concrete structures. From theory to applications. Chapman & Hall, London, London 1989, 407 pp (ISBN 0 412 30680 8).
- Fagerlund, Göran; Elfgren, Lennart and Skarendahl, Åke (1996). Swedish R&D Program on High Performance Concrete. International Workshop on High Performance Concrete (Ed Paul Zia), Special Publication SP-159, American Concrete Institute, ACI, Farmington Hill 1996, pp 247-261.
- Hedlund, Hans; Westman, Gustaf; Emborg, Mats; Jonasson, Jan-Erik and Bernander, Stig (1997): Hardening Technology for Concrete Structures. Advanced Design of Concrete Structures (Ed. K Gylltoft, B Engström, N-E Wiberg and P Åhman), International Center for Numerical Methods, CIMNE, Barcelona 1997, pp 313-318 (ISBN 84-87867-94-4).
- Hillerborg, Arne, Modeér, Matz, Pettersson, Per-Erik (1976). Analysis of crack formation and crack growth in concrete by means of fracture mechanics and finite elements. Cement and concrete research, Vol 6, 1976, pp 773-782.
- Gabrielsson, Henrik and Elfgren, Lennart (1996): Toughness in prestressed high performance concrete structures - Hollow core slabs and cylindrical poles. Utilization of High Strength/High Performance Concrete, (Edited by F de Larrard, R Lacroix) Presses des Ponts et Chaussées, Paris, May 1996, Vol 3, pp 1047-1056 (ISBN 2-85978-259-1).
- Gabrielsson, Henrik and Elfgren, Lennart (1997): Ductility of High Performance Concrete Structures - Hollow Core Slabs. Advanced Design of Concrete Structures (Ed. K Gylltoft, B Engström, N-E Wiberg and P Åhman), International Center for Numerical Methods, CIMNE, Barcelona 1997, pp 257-264 (ISBN 84-87867-94-4).
- Gabrielsson, Henrik (1997) Prestressed Hollow core slabs subjected to shear, flexure and torsion. Report K2:7. High Performance concrete. Div of Struct Eng, Luleå Univ of Techn, Luleå 1997 (to be published).
- Groth, Patrik and Noghabai, Keivan (1996): Fracture mechanics properties of steel fibre-reinforced high-performance concrete, Utilization of High Strength/High Performance Concrete, (Edited by F de Larrard, R Lacroix) Presses des Ponts et Chaussées, Paris, May 1996, Paper No 215, Vol 2, pp 747-756 (ISBN 2-85978-258-3).
- Groth, Patrik and Olofsson, Thomas (1997): Size Effects on Flexural Toughness of Steel Fibre Reinforced Concrete. Advanced Design of Concrete Structures (Ed. K Gylltoft, B Engström, N-E Wiberg and P Åhman), International Center for Numerical Methods, CIMNE, Barcelona 1997, pp 271-278 (ISBN 84-87867-94-4).
- Gustafsson, Jonas (1997): Steel fibres as shear reinforcement in high strength concrete beams. M Sc Thesis, Division of Structural Engineering, Luleå University of Technology Report 1997:252 CIV, Luleå 1997, 124 pp.
- Noghabai, Keivan (1995): Splitting of concrete in the anchoring zone of deformed bars. A fracture mechanics approach to bond. Licentiate thesis 1995:26L, Div of Struct Eng, Luleå Univ of Techn, Luleå, 1995, 131 + 56 pp.
- Noghabai, Keivan (1996): Environmental effects on bond in reinforced concrete structures. Pro-ceedings of the Seventh International Conference on Durability of Building Materials and Components, 7DBMC (Edited by Christer Sjöström), Stockholm, 19-23 May 1996, Vol I, pp 605-614. E & FN Spon (ISBN 0-419-22130-1).
- Noghabai, Keivan (1997): Environmental Effects on Bond Between Deformed Bar and Concrete - A Fracture Mechanics Approach. Fourth Canmet/ACI Int Conference on Durability of Concrete. Supplementary Papers. Sydney Australia 1997, pp 189-203.

Noghabai, Keivan; Olofsson, Thomas and Elfgren, Lennart (1997): Fracture Mechanics Applied to Bond. *Advanced Design of Concrete Structures* (Ed. K Gylltoft, B Engström, N-E Wiberg and P Åhman), International Center for Numerical Methods, CIMNE, Barcelona 1997, pp 57-64 (ISBN 84-87867-94-4).

Ohlsson, Ulf and Olofsson, Thomas (1997): Mixed mode fracture and anchor bolts in concrete. Analysis with inner softening bands. *Journal of Engineering Mechanics*, American Society of Civil Engineers, ASCE, Vol 123, No 10, October 1997, pp 1027-1033.

Olofsson, Thomas, Noghabai, Keivan, Ohlsson, Ulf and Elfgren, Lennart(1995): Anchorage and bond properties in concrete. *Fracture of brittle disordered materials: concrete, rock and ceramics*, (eds G Baker and B L Karihaloo), E & F N Spon, London 1995, pp 525-543 (ISBN 0 419 19050 3).

Paulsson, Björn; Töyrä, Björn; Elfgren, Lennart; Ohlsson, Ulf and Danielsson, Georg (1997): Increased Loads on railway Bridges of Concrete. *Advanced Design of Concrete Structures* (Ed. K Gylltoft, B Engström, N-E Wiberg and P Åhman), International Center for Numerical Methods, CIMNE, Barcelona 1997, pp 201-206 (ISBN 84-87867-94-4).

Tepfers, R. (1973): A theory of bond applied to overlapped tensile reinforcement splices for deformed bars. *Dissertation, Publication 73:2, Div of Concrete Structures, Chalmers University of Technology, Göteborg*, 328pp.

Täljsten, Björn (1995): Strengthening of structures using epoxy bonded steel or fibre reinforced plastic plates. *Extending the Lifespan of Structures. IABSE Symposium San Francisco 1995*, International Association for Bridges and Structural Engineering, IABSE, Zürich 1995, pp 1173-1179.

CORROSION PROCESSES IN HIGH PERFORMANCE CONCRETE - A New Perception Is Required



Per Fidjestøl
Ass. Prof., Elkem ASA Materials,
N-4602 KRISTIANSAND,
NORWAY

ABSTRACT

The introduction of high performance concrete has meant that many of the factors previously governing the occurrence and development of corrosion processes in concretes may no longer be entirely valid.

This paper aims to introduce a model of the steel/concrete interface as well as some thoughts on the possible consequences of the changed materials properties. Both in order to better explain and predict corrosion behaviour.

Keywords:

chloride, corrosion, concrete, silica fume, service life

1 Background

The last years have given numerous studies concerning corrosion of steel in concrete, in particular chloride initiated corrosion. Most of these studies have, however, targeted the transport of chlorides through the concrete cover to the steel surface, rather than the actual mechanisms and dynamics of the initiation and growth of corrosion. In sum, the profession now knows a lot about how to make concretes that are highly resistant to chloride penetration. So, if this was the only problem, what remains is to implement this knowledge in practice and supplement it with design and construction quality worthy of these high tech materials.

However, the approach above is at best insufficient, and worse, uneconomical, for the reason that mechanisms and criteria are insufficiently understood. Therefore elaborate lifetime models, based upon the regression of lab-measured chloride concentration profiles to fit an error function (such as "Fick's law"), are woefully inadequate. (In addition, many, if not all structures will contain imperfections in the cover, such as cracks.)

One reason for this state of affairs is that the actual appearance of the steel concrete interface and the way in which this interface and its properties influence the corrosion process have not yet been described in a model/hypothesis which have gained general acceptance.

2 Introduction

The purpose of durable concrete design is to provide an adequate service life or, rather, service life economy. In design against chloride initiated corrosion, it can be argued that the lifetime model which solely considers the initiation time, i.e. the time for chloride concentration to reach the (assumed) threshold level may have to be considered a blind alley, since cracks and other imperfections must be anticipated in concrete structures.

(It is a paradox that a very large proportion, some say 90-95%, of all damage to concrete structures is caused by errors in design or execution, thus only 5-10% can be attributed to poor materials design. On the other hand, materials receive (at least from our vantage point) the lions share of attention.)

Be that as it may, some of the many issues that are unclear are:

- Cracks and imperfections - what are their effect; can they be disregarded, will environment and concrete quality determine the importance?
- Pitting - Which environments are conducive to pitting, can materials design do anything to alleviate the likelihood of pitting?
- Corrosion rate in pits. Under which circumstances will pits develop to an autocatalytic state? Can the materials selection do anything to control this?
- In sum: Will it be possible to design for (against) pitting corrosion?
- Can physical models be made which explain the effect of high performance concrete, particularly with microsilica.
- Leakage current to maintain passivity, will concrete quality influence the required current, and the availability of sufficient oxygen to maintain passivity?

Then, general assumptions which must be supported by the model the physical model are:

- The qualities of the concrete material are essential for the corrosion behaviour of steel embedded in concrete.
- The chloride threshold value of the steel is strongly influenced by the concrete quality.
- The quality of the interfacial layer (primary layer) is strongly influenced by the concrete composition and will, by itself, strongly influence the threshold limit values in undamaged concrete.
- The ability of a pit to go autocatalytic can (may) be controlled by the concrete mixture composition
- The resistivity of the electrolyte is paramount, thus increasing the resistivity of the concrete will add protection against, among other, autocatalytic pitting
- Regardless of ability to resist chloride penetration, the ability to limit corrosion growth is an essential parameter
- Concrete will in practice be cracked

3. Anticipated mechanisms

The properties of the interfacial zone probably varies a lot with the concrete properties - as does the bulk concrete. The high SiO_2 content of microsilica concrete is expected to influence the interface, increasing its Si content and combining with iron, thus giving better steel-concrete interface properties as well as an electrochemical effect on the initiation process. (It should also be kept in mind that silicates are sometimes used as anodic inhibitors in water. The ability of microsilica to contribute to this effect has apparently not been studied, but actually, some of the conditions necessary for anodic inhibition appear to be present!)

Furthermore; several pozzolana based concretes exhibit very interesting properties in terms of resistivity. This increased resistivity should have a profound influence on the corrosion process.

Which conditions give the most aggressive corrosion. How will dense concretes with reduced permeability influence the ranking of corrosion environments?

4. The model

The proposed model for the steel/concrete system is based on work done in Stockholm at CBI by Karin Pettersson and at MI (Metal Institutet) by Sofia Bertling. Their studies involved looking at the immediate and close by areas of the steel-concrete interface, in order to describe their composition. Their main finding is illustrated in the figure. From this diagram it can be seen that the steel concrete interface can be divided into three main parts:

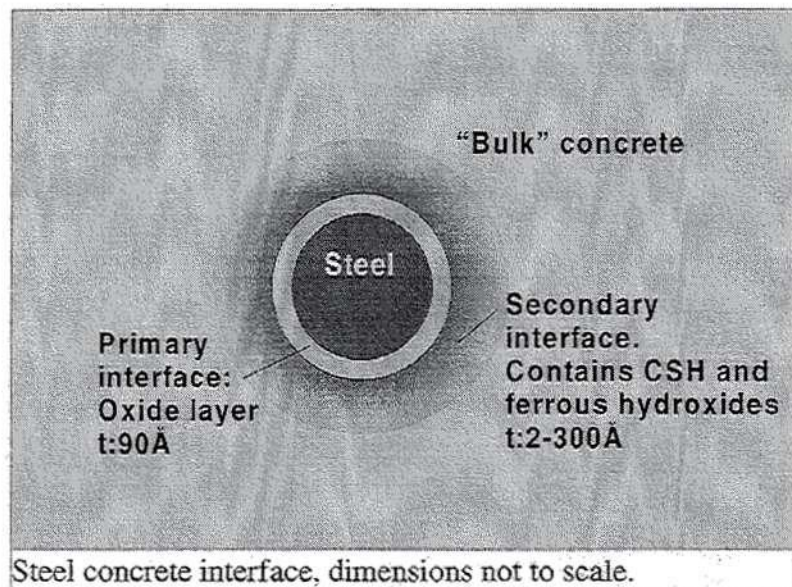

Primary interface:

The "real" passive oxide layer. 30-90 Å in thickness, with probable defects.

Secondary interface: Mainly CSH, but also ferrous oxides. Dense layer, protects the film of the primary interface. Increases with time? >200Å.

Bulk concrete/paste: Really two zones; a paste rich phase close to the steel, more average concrete further out.

Part 1 of the working hypothesis is that the primary passive layer is given protection; mainly by the presence of the secondary interface, secondly by the bulk concrete. The

secondary interface normally provides strong resistance to the penetration of chlorides, and also partly compensates for imperfections in the oxide film which would otherwise be susceptible to attack from chloride ions that penetrate the cover concrete.

Thus, in the case of a perfect and complete secondary interface the system will be very resistant to chloride initiated corrosion. The cause for chloride initiated pitting would then be that the secondary interface has imperfections which give a certain probability that chloride ingress will coincide with imperfections in the oxide layer.

Such imperfections in the secondary layer could be voids, channels along aggregate particles that are in contact with the steel, and cracks that are sufficiently continuous to allow chloride ingress.

For chloride ingress, the effect of using high performance concrete with microsilica is to improve the quality of the secondary interface, especially with respect to the aggregate paste interface, eliminating the channeling described above. Often, high performance concrete can also allow increased amounts of vibration, thus reducing the incidence of voids adjacent to the surface.

The final effect of high performance concrete is therefore assumed to be improved secondary interface, reducing the probability that chlorides penetrating to it shall gain access to and attack the passive layer. This in addition to improved (reduced) chloride diffusivity of the concrete cover in general through the use of high performance concrete. Additionally, suggestions have been made that the increased concentration of reactive SiO_2 in the interfacial region can cause the integration into the actual passive film of compounds of ferrous silicates, thus strengthening it against attack from chlorides.

Part 2 of the hypothesis focuses on the effect of high concrete resistivity, especially when microsilica is part of the mixture. The ability of a pit to initiate and grow will be influenced by the available cathode area. Thus, in conventional concrete, one would expect a pit to be able to cathodically polarize the steel for a fairly "large" distance, thus preventing the formation of adjacent pits; again implying high rate of corrosion in the pit due to the large cathode to anode ratio.

Correspondingly, if the resistivity of the concrete gets very high, as with microsilica, the effect is to reduce the "throw" of a pit, i.e. the distance from the pit where a cathode can contribute. This means that a new pit can form closer than is the case for conventional concrete. The rate at which pits can corrode is also reduced; firstly because of the reduced cathode area, secondly because of the resistivity itself, causing an increased voltage drop at a given corrosion current. This means: If the likelihood of pit formation remains constant, the corrosion will be distributed over a multiple of pits and thus will be much less severe in terms of cross section reduction as well as actual corroded volume.

If parts 1 and 2 are combined, there could be the following consequence: Due to the improved quality of the steel concrete interface, in particular the so-called secondary interface; the number of incidences of possible pit formation is reduced, - and - due to the increased resistivity of the concrete, any pits that form will be smaller.

5. Verification

Verification tests are in the starting phase. They will involve exposing to chloride (undamaged) specimens of mortar, concrete and, if feasible, paste; all cylindrical with centrally mounted reinforcement. Corrosion threshold values at various polarisation levels and corrosion rates after initiation will serve to give data for evaluation of the model.

**CONCRETE WORKABILITY: A MORE BASIC APPROACH
NEEDED**

Odd E. Gjerv
Professor, Dr.
Building Materials
Dep. of Civil Engineering
NTH
N7034-Trondheim, Norway

Synopsis: Over recent years, there has been a rapid development in the field of concrete technology. However, new cements and new mineral and chemical admixtures affect the fresh concrete workability in a way that is not properly reflected by empirical test methods. Also, new production techniques require more proper specifications of the fresh concrete properties. There is a great need, therefore, to take a more basic approach to the testing and specification of the fresh concrete workability. In the present paper, some recent experience on the use of a coaxial cylinders viscometer for testing of fresh concrete properties are presented.

Keyword: Fresh concrete, workability, testing, rheology, yield stress, plastic viscosity.

BACKGROUND

Since Powers and Wiler (1) introduced their plastometer in 1941, several attempts have been made to take a more basic approach to the testing of concrete workability (2-14). Most of these attempts, however, have only resulted in various types of prototype equipment. In spite of a rapid development from craftsmanship to an advanced concrete industry, still, the most common way of testing fresh concrete workability is based on various types of empirical test methods, such as the slump method that was introduced by Abrams (15) in 1918. It was a great step forward, therefore, when Tattersall (16) introduced his two-point test apparatus for measuring concrete workability in 1973. In 1982 experimental work based on this two-point workability apparatus was started at the Norwegian University of Science and Technology in Trondheim. It soon became clear, however, that two main problems made the operation of this test apparatus somewhat difficult and unreliable. One of the problems was segregation of the concrete during testing. Another problem was errors arising from difficult equipment operation. Therefore, modifications of the equipment and testing procedure were first made (17), and later on, a completely new coaxial cylinders viscometer was developed (Fig. 1). Over recent years, extensive work has been carried out on the basis of this equipment (19-25).

The BML Viscometer is fully automatic and controlled by a computer. A software program provides all information necessary in order to carry out the test. To a certain extent, the software also provides further assistance such as how to adjust a mixture design in order to obtain a required workability. The equipment is easy to operate and appears to give good reproducibility with a minimum of segregation during testing. Basic rheological information on the concrete workability is obtained.

In principle, the testing is based on a Bingham behavior of the fresh concrete, which is roughly the case for the most common shear rates occurring during handling and placing (16). For a Bingham behavior, we have:

$$\tau = \tau_0 + \mu\gamma$$

where:

- τ = shear stress
- τ_0 = yield stress
- μ = plastic viscosity
- γ = shear rate

In rheology, yield stress and plastic viscosity are normally measured as parameters dependent of the instrument applied and expressed in torque units. Thus, the units for yield stress and plastic viscosity are Nm and Nms, respectively.

By measuring the torque or the shear stress produced on the stationary, inner cylinder, while the outer cylinder is rotating at various speed settings or shear rates, the values of τ_0 and μ are determined. These two parameters characterize the workability of the fresh concrete in a basic way, where:

- τ_0 : is a measure of the force necessary to start a movement of the concrete ("flow resistance")
- μ : is a measure of the resistance of the concrete against an increased speed of movement ("viscosity")

Upon completion of the test, the speed of the other cylinder automatically goes back to Speed Set 1 for control of the first torque reading. If there is any deviation from that observed at the start of the test, a segregation of the concrete during testing has taken place. Thus, the proneness of the fresh concrete mixture to segregation is also automatically quantified in the form of a segregation factor.

WORKABILITY TESTING

Since there is a linear relationship between shear stress and shear rate in the concrete, at least two points have to be determined in order to establish this relationship. Therefore, since all empirical test methods only apply one shear rate, the results from two empirical test methods based on two different shear rates can never be compared. The one-point methods can only reflect the response of the fresh concrete to the particular shear rate or action applied.

In Fig. 2, the shear rates γ_s and γ_w are equivalent to that of a slump test and a wattmeter test during concrete mixing, respectively. Thus, for two different concrete mixtures A and B, Mixture A has the lowest shear stress at shear rate γ_w and will be considered to have the "best workability" based on the wattwater test, while Mixture B has the lowest shear stress at shear rate γ_s , and hence will be considered to have the "best workability" based on the slump test.

Therefore, in order to obtain a more general characterization of the concrete workability, it is important to test the flow properties over a certain range of shear rates. By measurement of the yield stress (τ_0) and the plastic viscosity

(μ), a good basis for evaluating both the flowability and the compactability of the fresh concrete is obtained (Fig. 3). A very good basis is obtained also for evaluating the effect of various constituent materials on the concrete workability (19-25).

EFFECT OF CONSTITUENT MATERIALS

Effect of water and admixtures

Some typical effects of water (W), a water reducing admixture (P) and a superplasticizer (SP) on the yield stress and the plastic viscosity are shown in Fig. 4. The figure also shows the effect of an air-entraining admixture (AE).

If the dosage of the superplasticizer is increased up to 2.4% by weight of cement while the water content is reduced and the slump is kept constant, the plastic viscosity is significantly increased as shown in Fig. 5. The time effect of the superplasticizer is also demonstrated. If the plastic viscosity becomes too high such as often being the case for a high-performance concrete with much superplasticizer, it can be seen from Fig. 4 that a proper addition of an air-entraining admixture may effectively reduce the plastic viscosity again.

Effect of cement type and silica fume

Some typical effects of ASTM Type I and Type III cements on the yield stress and the plastic viscosity are shown in Fig. 6. The figure also shows the effect of a modified portland cement (MP) containing 20% fly ash. An increasing amount of cement from 200 up to 400 kg/m³ primarily affected the yield stress, while the plastic viscosity was not so much affected. While there was no big difference between the two types portland cement, the beneficial effect of fly ash on the workability was clearly demonstrated.

If the portland cement is replaced by an increasing amount of condensed silica fume (CSF), Fig. 7 demonstrates that the plastic viscosity is strongly reduced down to a certain threshold level, while the yield stress is almost unaffected. For these particular concrete mixtures, the threshold levels were approximately 2, 4 and 6% for a cement content of 200, 300 and 400 kg/m³, respectively. For higher contents of silica fume above the threshold levels, a substantial increase of yield stress takes place, while the plastic viscosity starts to increase again. If the silica fume is used as an addition to the cement instead of being used as a replacement, the same behavior is observed, but without so distinct threshold levels (Fig. 8).

By testing the effect of silica fume on plastic viscosity and yield strength, Fig. 7 and 8 clearly demonstrate that even small additions of silica fume may affect the fresh concrete workability in such a way that neither the "static" nor the "dynamic" behavior can be compared to that of a concrete without silica fume. Due to increased cohesiveness, the slump measure does not predict the flow or response to compaction in the usual way. Therefore, an increased slump for silica fume concrete is normally recommended compared to that of "normal" concrete.

Even small additions of silica fume will also impart stability to the fresh concrete mixture. This may be a very important effect both during transportation, handling and placing of the concrete. During the viscometer testing, information about the stability of the concrete mixture is automatically obtained.

Effect of aggregate

In the mixture design, special types and amounts of fine and coarse aggregate may have a special impact on the fresh concrete behavior. From Fig. 9 it can be seen that by increasing the amount of coarse aggregate from 40 to 55%, the yield strength was significantly reduced, while the plastic viscosity was not much affected. By going from a crushed coarse aggregate to a gravel type of aggregate, however, the plastic viscosity was also distinctly reduced. Special types of filler materials may further have a special effect on the rheological behavior of the fresh concrete (23).

CONCLUDING REMARKS

Over recent years, there has been a rapid development in the field of concrete technology. New cements and new mineral and chemical admixtures affect the fresh concrete workability in a way that is not properly reflected by empirical test methods. Also, new production techniques require more proper specifications of the fresh concrete properties. There is a great need, therefore, to take a more basic approach to the testing and specification of the fresh concrete workability.

REFERENCES

1. Power, T.C. and Wiler, E.M., "A Device for Studying the Workability of Concrete", Proceedings, ASTM, Vol. 41, 1941, pp. 1003 - 1015.

2. L'Hermite, M.R. and Tournon, M.G., "La vibration du beton frais", *Annales de l'institut technique du batiment et des travaux publics*, New series No. 11, 1948, pp. 1-75.
3. L'Hermite, M.R., "The Rheology of Fresh Concrete under Vibration", *Cement and Concrete Association*, Translation No. 9, 1949, pp. 1-32.
4. Eriksson, A.G., "Development of Fluidity and Mobility Meter for Concrete Consistency Test", Report No. 12, The Cement and Concrete Institute, Stockholm, 1949.
5. Ritchie, A.G.B., "The Triaxial Testing of Fresh Concrete", *Magazine of Concrete Research*, Vol. 14, No. 40, 1962, pp. 37-41.
6. Tassios, T.P., "Plasticity and Cohesioness of Fresh Concrete", *RILEM Seminar*. Paper 1.3, Leeds, 1973, pp. 1-38.
7. Mizuguchi, H., Fujisaki, S. and Ohshiro, T., "Measurement of Plastic Viscosity and Yield Value of Fresh Concrete", *Review of the 28th General Meeting, The Cement Association of Japan*, 1974, pp. 100-102.
8. Mizuguchi, H. Katano, M. and Shimizu, T., "Fundamental Study on the Properties of Fresh Mortar by Means of Rotation Viscometer", Report No. 24, Tokushima University, 1979, pp. 13-23 (in Japanese).
9. Bache, H.H., "Stability of Fresh Concrete", *Betonteknikk*, No. 3, Aalborg Portland, Aalborg, 1978 (in Danish).
10. Okamoto, H., "Basic Study of Evaluation of Workability of Fresh Concrete", *Transactions, Japan Concrete Institute*, Tokyo, Dec. 1979.
11. Nishibayashi, S., Yamura, K. and Inoue, S., "Rheological Properties of Superplasticized Concrete", Publication SP-68, American Concrete Institute, Detroit 1981, pp. 441- 466.
12. Kishitani, K., Tomosawa, F. and Oka, S., "Rheological Study of Superplasticized Concrete", Publication SP-68, American Concrete Institute, Detroit 1981, pp. 423-440.
13. Jensen, J.K.J., "Workability of Fresh Concrete", Report No. 8210. Aalborg University Centre, 1982, 231 p. (in Danish).

14. Murata, J. and Kikukawa, H., "Flow and Deformation of Fresh Concrete", *Matériaux et Constructions*, Vol. 17, No. 98, 1984, pp. 117-129.
15. Abrams, D.A., "Design of Concrete Mixes", Structural Materials Research Laboratory, Levis Institute, May 1925, pp. 1-20, Reprints from Minutes of the Annual Meeting of the Portland Cement Association, New York, December 1918.
16. Tattersall, G.H., "Relationships Between the British Standard Test for Workability and Two-Point Test", *Magazine of Concrete Research*, Vol. 25, No. 84, 1973, pp. 169-174.
17. Wallevik, O.H. and Gjrv, O.E., "Modification of the Two-Point Workability Apparatus", *Magazine of Concrete Research*, Vol. 42, No. 152, 1990, pp. 135-142.
18. Wallevik, O.H. and Gjrv, O.E., "Development of a Coaxial Cylinders Viscometer for Fresh Concrete", RILEM, Proceedings of the International Conference on Properties of Fresh Concrete. H.J. Wierig, ed. Chapman and Hall, London, 1990, pp. 213-224.
19. Wallevik, O.H., "The Fresh Concrete Rheology and the Application on Concrete with and without Addition of Silica Fume", Dr.ing. Dissertation 1990:45, Norwegian University of Science and Technology, Trondheim, 1990, 185 p. (in Norwegian).
20. Mork, J. H., "Effect of Gypsum - Hemihydrate Ratio in Cement on Rheological Properties of Fresh Concrete", Dr.ing. Dissertation 1994: 4, Norwegian University of Science and Technology, Trondheim, 1994, 286 p. (in Norwegian).
21. Ghio, V.A., Monteiro, P.J.M. and Gjrv, O.E., "Effect of Polysaccharide Gums on Fresh Concrete Properties", *ACI Materials Journal*, Vol. 91, No. 6, 1994, pp. 602 - 606.
22. Hu, C., deLarrard, F. and Gjrv, O.E., "Rheological Testing and Modelling of Fresh High Performance Concrete", *Materials and Structures*, Vol. 28, No. 175, 1995, pp. 1 - 7.
23. Wallevik, O.H., Saasen, A. and Gjrv, O.E., "Effect of Filler Materials on the Rheological Properties of Fresh Concrete", *ACI Materials Journal*, Vol. 92, No. 5, 1995, pp. 524 - 528.

24. Punkki, J., Golaszewski, J. and Gjrrv, O.E. "Workability Loss of High-Strength Concrete", ACI Materials Journal, Vol. 93 No. 5, 1996, pp. 427 - 431.
25. Mork, J.H. and Gjrrv, O.E., "Effect of Gypsum-Hemihydrate Ratio in Cement on Rheological Properties of Fresh Concrete", ACI Materials, Vol. 94, No. 2, 1997.

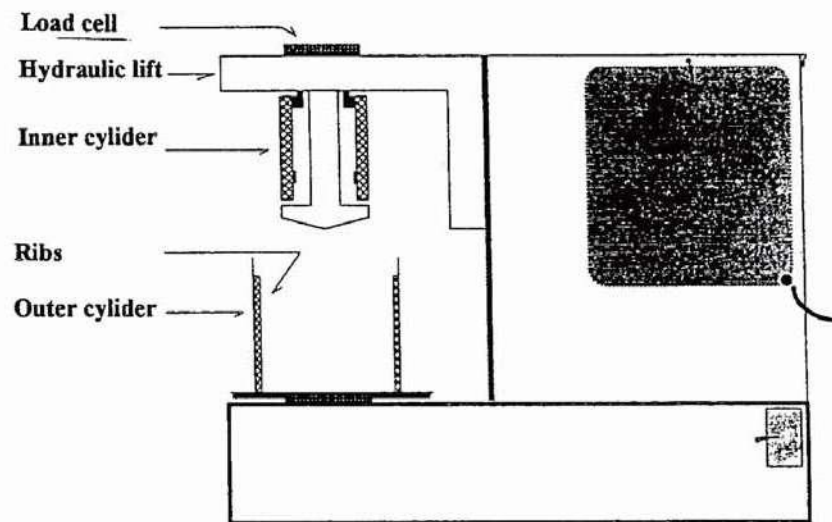

Fig. 1. Schematic diagram of the BML Viscometer (18).

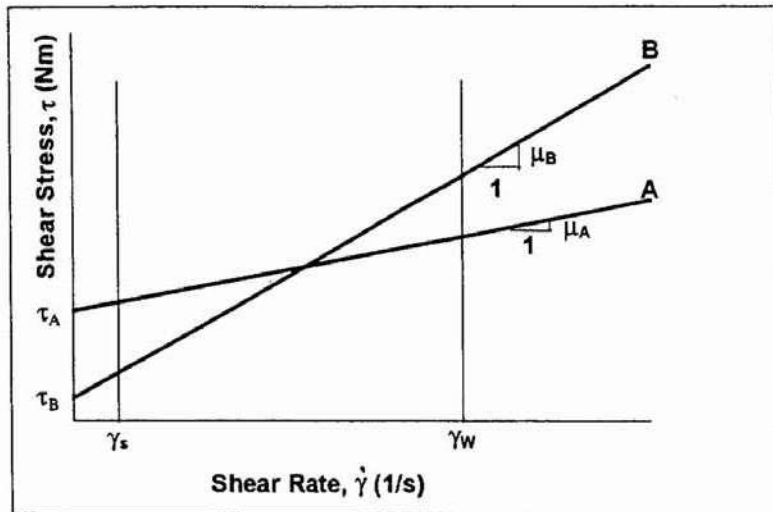

Fig. 2. Relationship between shear rate and shear stress for two types of concrete A and B.

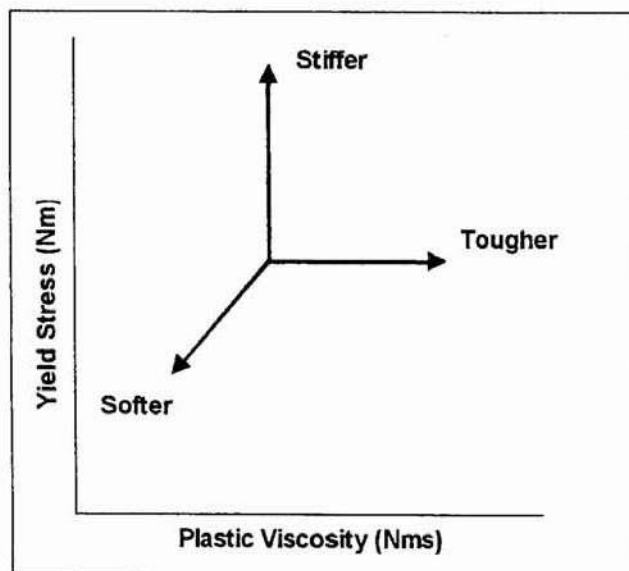

Fig. 3. Relationship between plastic viscosity and yield stress.

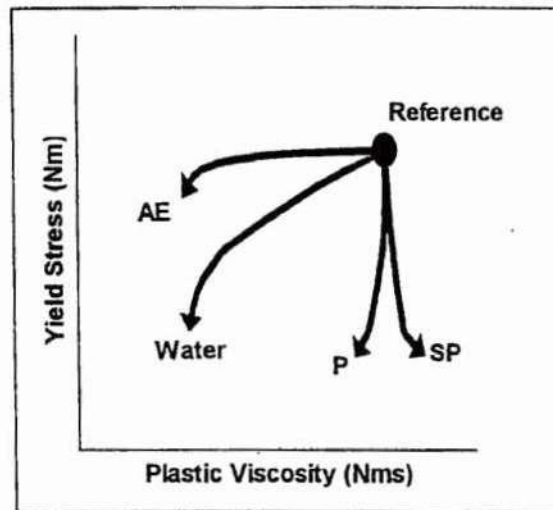

Fig. 4. Effect of water compared to that of a plasticizer (P), a superplasticizer (SP) and an air-entraining admixture (AE) on the rheological behavior of concrete.

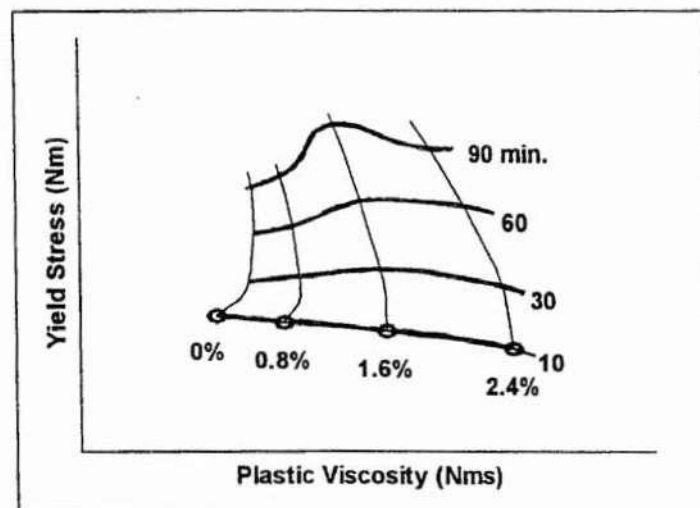

Fig. 5. Effect of a superplasticizer on the rheological behavior of concrete at different times after addition.

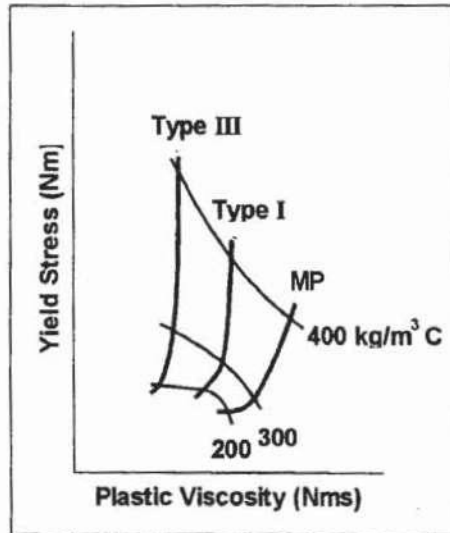

Fig. 6. Effect of different types of cement (ASTM Type I and III and a modified portland cement MP) on the rheological behavior of concrete.

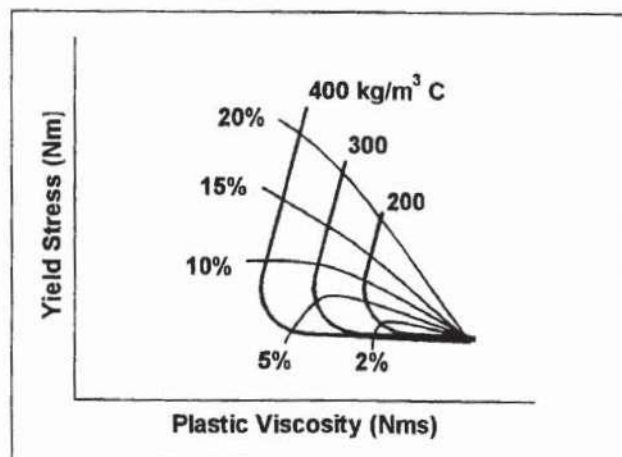

Fig. 7. Effect of condensed silica fume (CSF) on the rheological behavior of concrete on a replacement basis.

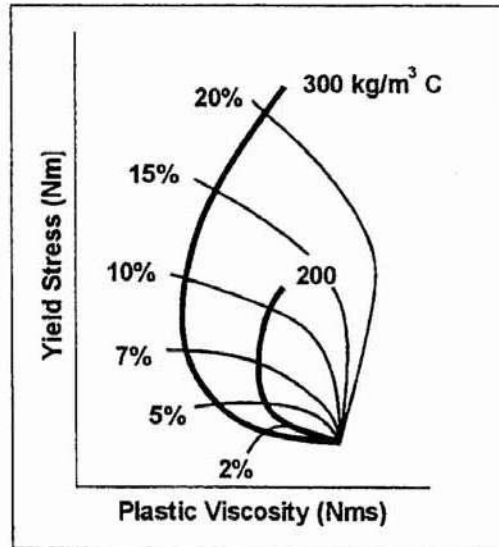

Fig. 8. Effect of condensed silica fume (CSF) on the rheological behavior of concrete on an addition basis.

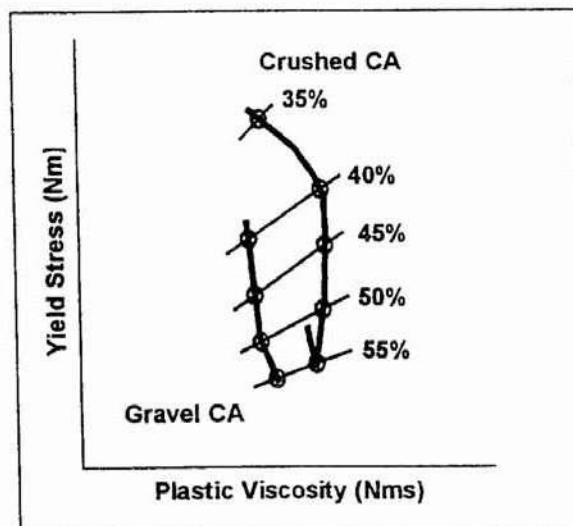

Fig. 9. Effect of a gravel type of coarse aggregate compared to that of a crushed coarse aggregate on the rheological behavior of concrete.

PREVENTION OF REBAR-CORROSION.



Ulf A. Halvorsen
 Professor, Dr.ing
 Narvik Institute of Technology
 N-8501 NARVIK
 NORWAY

ABSTRACT

In the article is presented a proposal of a method for prevention of corrosion of reinforcement bars in concrete structures. The proposed method is based upon general knowledge of concrete technology and the corrosion process in concrete, combined with experience related to prefabricated and integrated forms, polymer impregnation of concrete and ferro-cement technology.

Key words: Rebar-corrosion, polymer-impregnation, ferro-cement.

1 INTRODUCTION

“ Concrete is my field of work. My future, my prosperity and the welfare of my family is dependent on the quality of the work that I do. Among all the existing construction materials of our earth I have chosen concrete as the material in which I have wanted to specialise . Mixed and placed by knowing (and loving) hands it will not let me down. Therefore the work that I carry out now will survive and serve its purpose long after I have gone !”

This “ declaration of love and trust” with reference to the material *Concrete* was expressed by an American contractor about 30 years ago, and to some extent I can say that these words also can represent my own feelings about this material. I must, however, admit that my prosperity to a larger extent has been dependent on the **lack of knowledge** in the hands of those who mixed and placed most of the concrete that I have been asked to investigate.

Unfortunately for the owners of the structures is it therefore true to say that the prerequisite given by the words *knowing hands* , necessary for the concrete to behave as stated by our contractor- that is to survive and serve its purpose for a long period even after the death of the contractor- has not always been present. And we have seen concrete structures deteriorate and brake down by aggressive forces far to early in their lives.

2. CORROSION OF REINFORCEMENT BARS.

For concrete structures in aggressive environments, such as along the Norwegian coast, with salty ocean waters and rough and stormy weather, the by far most serious cause of deterioration of the concrete is corrosion of the reinforcement bars. This is now common knowledge, but we need not go far back in time to learn from the textbooks on concrete technology, that "as long as the reinforcement is embedded in sound and good concrete, the bars are protected from corrosion due to passivation of the iron surface caused by the alkaline environment in the concrete, with pH in the region of 12,5 .

What was left out here is the now well known fact that the surface concrete is exposed to chemical changes and attack, and that some of these will eventually lead to depassivation and destruction of the passive layer, and open the way for an active corrosion process. The most important of such changes which are leading to initiation of active corrosion are:

- a) *Carbonation* , by which the pH of the surface concrete will drop to below 9, and the passive layer will be lost,

and

- b) *Chloride penetration* through the concrete surface layer, and when the chlorides reaches the reinforcement bars, the passive layer will be affected and serious local corrosion (pitting), and eventually general corrosion may occur.

In this presentation I am not going into any detailed discussion of the corrosion process and the factors that may affect this process, but just refer to the now famous and universally known *Tuutti-model* of corrosion of steel in concrete, figure 1.

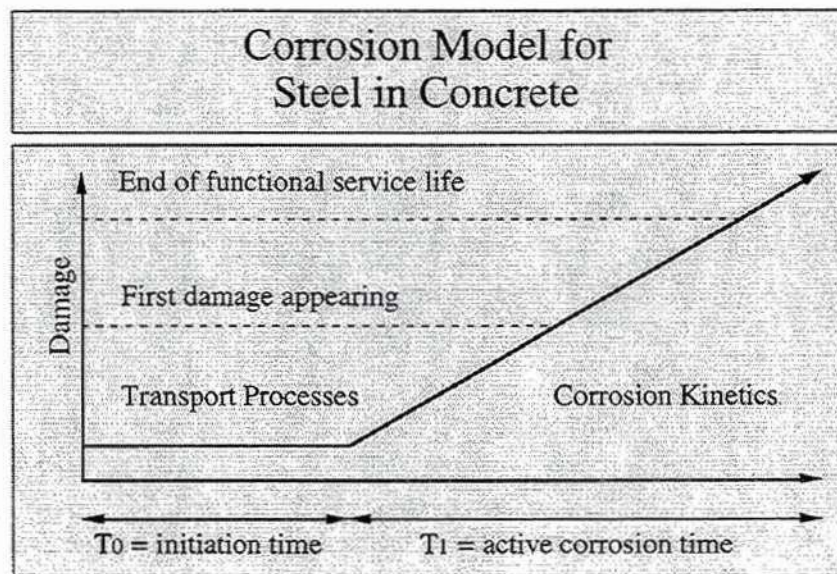

Figure 1. Model of corrosion of steel in concrete (acc. to K. Tuutti)

The objective of my paper is to present a proposal for developing a method to prevent corrosion of reinforcement (and most likely also other forms of concrete deterioration) in aggressive environments. In this context one should also have in mind that, in addition to the needed absence or partly destruction of the passive layer, moisture and oxygen are also normally required to maintain an active corrosion process.

3. SURFACE CONCRETE.

Before presenting the proposed method, I would like to give some thoughts with regard to concrete quality and the durability of concrete.

When we are discussing durability of concrete it can be useful to divide the structures into two main parts, such as :

- a) the *Surface concrete*,
- and
- b) the *Internal concrete.(core-concrete)*

The surface concrete may be defined as the outer layer of concrete, to a depth reaching the first layer of reinforcement bars, and is normally referred to as the *concrete cover*. The internal concrete will then be the rest of the concrete in the structure.

As far as the durability of the structure is concerned, the quality and the properties of the surface concrete is the major factor influencing the resistance of the concrete to the attacks by aggressive, environmental forces (loads). This is true particularly when we are discussing the risks of rebar- corrosion. But it is also valid for other forms of concrete deterioration, such as frost attacks, chemical attacks and mechanical erosion. In popular terms one can say that the surface concrete should have a quality and properties sufficient to prevent the attacking agents from entering into the structure.

Unfortunately, this may seem to be only some unrealistic dream thoughts, since the surface concrete is the part of the structure which in the real world of concrete contractors, is most likely to end up as the weakest link of the structure. This is true due to the fact that the surface concrete is taking all kinds of licking during both the concreting period and afterwards during the curing, hardening and the drying-out period. The surface concrete will end up with a different and lower quality than the rest of the structure due to several different effects, all of them negative :

- screening and separation during concreting
- poorer curing conditions, early drying of the surface

- air pockets, surface pores
- poor compaction
- drying shrinkage, surface cracks
- temperature gradients, surface cracks

During the service life of the structure, the internal concrete may improve its strength and quality, while the surface concrete is exposed to unfriendly environmental conditions, and finally unable to protect the structure from deterioration.

4. PREVENTION OF REBAR-CORROSION.

The surface concrete, or the concrete cover, defined by its quality and its thickness, is the critical part of the structure in regard to the length of the initiation time, before there is active corrosion of the rebars. During this period moisture, oxygen, carbon dioxide and chlorides may penetrate through the cover and finally reach the reinforcement, and active corrosion can begin.

After having learned some very expensive lessons, concrete designers are now specifying several methods to avoid corrosion. Such methods include

- increased thickness of the cover
- reduced W/C-ratio, use of silica-fume
- admixtures (hydrophobic, inhibitors, latex)
- coated reinforcement (epoxy, galvanizing)
- non-metallic reinforcement (glass or carbon fibres)
- coatings (chloride-barriers, membranes, surface impregnation)
- increased execution control, curing efforts, compaction control
- cathodic protection
- realkalization, chloride extraction
- mechanical rehabilitation
- etc

In general most of these methods are costly, and some of them are also requiring extensive maintenance and control procedures during the service life of the structure. The efficiency of the various methods may also be questioned.

5. A NEW METHOD OF REBAR-CORROSION PREVENTION ?

There is a question mark after this heading, since I am not sure whether this method is actually new, and since the method is based upon just combining the use of well known technologies from different fields of construction technology.

From what is said above on the importance of the *surface concrete* as the guard of the structure against attacks from environmental forces, it may be assumed that if the surface concrete can be made practically impermeable to moisture, oxygen, carbon dioxide and chlorides, corrosion of the reinforcement will be permanently prevented.

The objective of this proposal is then to suggest a method by which this can be achieved, aiming at a development program to study the feasibility of the method, both economically and technically.

In short, the proposal is to use a permanent, integrated form-material of such quality that it will work as an impermeable cover over the reinforcing bars, and thus prevent the establishment of conditions required for active corrosion.

The proposal is based upon experience from 4 different areas of cement- and concrete technology:

1. General knowledge on concrete durability and rebar-corrosion.
2. Ferro-cement technology.
3. Polymer impregnation of concrete("PIC").
4. Concrete elements as permanent formwork ("lost form", or "integrated form ").

On point 1. I will just repeat my previous statement, that if moisture, oxygen, carbon dioxide and chlorides are practically prevented from reaching the reinforcement, the required conditions for an active corrosion process will be absent.

Ferro-cement can basically be described as a thin shell structure, made of highly reinforced cement mortar.

It is different from ordinary reinforced concrete in that the binding matrix - the cement mortar - does not contain coarse aggregates, and that the reinforcement is mainly made of several layers of wire-mesh. The amount of reinforcement in ferro-cement is higher than in ordinary reinforced concrete. And because of the high surface area of the wire mesh reinforcement and the effective anchoring of the mesh, the composite material behaves more like a homogeneous, elastic material.

The invention of ferro-cement dates back to the early 1940's, but wider industrial application of the invention did not start until the 1960's, when ferro-cement became widely accepted in UK, New Zealand, China and Australia as a boat building material. The inventor of the material, professor Nervi of Italy had, however, demonstrated the possibilities of the material for other applications in the construction industry, as for instance in thin shell, roofings.

Characteristic for the material is its good formability, and it can be given almost any kind of shape, and can be produced in plane, curved or double-curved panels. Normal thickness of the panels may be in the range of 15-25 mm.

Typical properties are:

- high compressive and tensile strength
- superior cracking behaviour in compared to reinforced concrete
- low permeability
- high impact and shock resistance
- high durability.

Typical areas of possible use, are:

- boat building
- tanks, containers, silos
- pipes
- fish farm structures
- roofing structures.

Raw-materials are cheap, and the main limitation of the material is that the production is labour intensive, and that industrialized production is difficult to use. For standardized products, industrialized production may, however, be developed.

Polymer Impregnated Concrete (PIC) is also a well known technology, with several research reports, in particular from the period after 1960 up to about 1985. The method is described in details in ACI Committee report 548: *Guide for the Use of Polymers in Concrete*.

This material is a hydrated portland cement concrete that has been, fully or partially, impregnated with a monomer that is subsequently polymerized. The void space available for the monomer is usually obtained by removing free water by drying of the concrete, after the initial curing period. The monomer is introduced into the concrete by either atmospheric or pressure soaking. The degree to which the available space in the concrete is filled with monomer during soaking, determines whether we will have partially or fully impregnated concrete. Full impregnation implies that about 85 % of the available void space is filled. After impregnation, the concrete containing the desired amount of monomer then undergoes a treatment to convert the monomer into a polymer.

A schematic model for a plant producing PIC, is shown in figure 2.

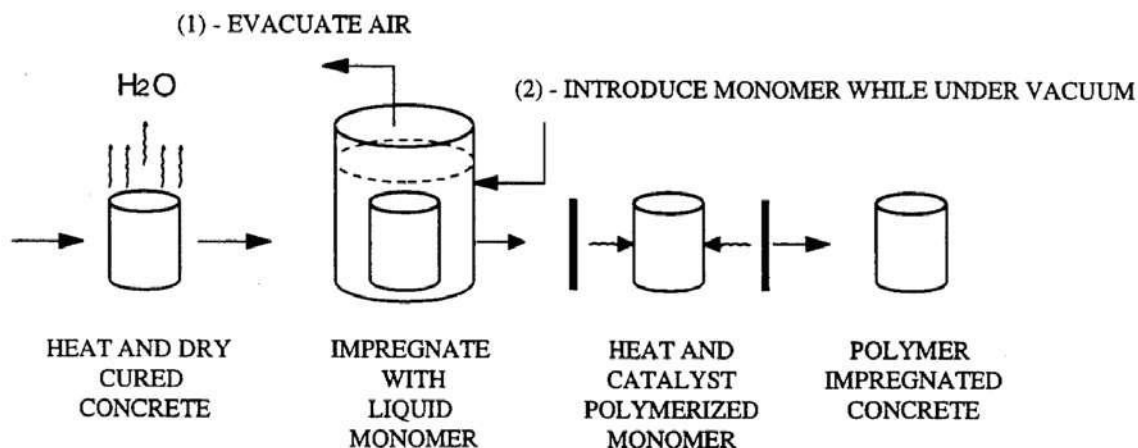

Figure 2: Schematic model for a plant producing polymer impregnated concrete.

Polymer impregnated concrete looks in general just like conventional concrete, but the properties have been improved in several ways. Increases in strength in compression, tension and flexure can be achieved with increases as much as four to five times. This improvement is also accompanied by improved resistance to water penetration and improved durability.

The limitations of the method is that it is almost completely limited to precast plant operations, and the examples of commercial and practical use of the method are very few. For obvious reasons, full impregnation of large concrete structures, such as bridges, is not feasible. The practical use is therefore limited to “low-cost-products”, and since the impregnation material is quite expensive, there has not yet been any commercial “breakthrough” for the method.

Another limitation is the safety aspect due to hazards and offensive odours of monomer vapours, and the plant should be a completely closed process, as far as impregnation and handling of the monomer is concerned

Permanent forms made of concrete panels which are integrated as structural elements in the finished structure, has been produced and used in a number of applications.

In general, such form-elements are produced in precasting plants, and they will normally be plane, reinforced elements of a thickness from about 40 mm and higher. They are mainly used as slab-forms for new construction of industrial floors, bridge-decks, car-parking buildings, harbour structures and similar ones. The elements will remain as permanent parts of the structure, and they are structurally integrated in the design of the structures. The term “lost form” is therefore not correct for this kind of form-elements. The term “integrated, precast form-elements” may be a more adequate description.

The advantages of such formwork are, for instance:

- Reduced time of construction, no form removal.
- Improved surfaces and finishing.
- Precasting advantages, quality assurance.
- Better control of positioning of reinforcement and cover.
- Simplified winter construction.

The proposal is now to use polymer impregnated ferro-cement elements as permanent, integrated forms, for concrete structures exposed to aggressive environments.

The basis for this proposal is thus to combine the use of ferro-cement technology, polymer impregnation and precast, integrated formwork.

By this method one will have a permanent surface cover, capable of

preventing rebar-corrosion, and other environmental attacks on the concrete structure.

By limiting the polymer impregnation to relatively thin panels (15 - 25 mm) of suitable sizes, one will reduce the use of expensive monomers. It will also be possible to establish an adequate production line for industrial production of such elements. The weight of the panels will be around 50 kg/m².

The method may, in addition to prevention of corrosion, have several other positive effects, compared to conventional methods. For instance :

- General improvement of the durability of the structure.
- Reduced - or practically removed - need of moist curing, where permanent forms are used.
- Reduced moisture content in the structure.
- Reduced shrinkage and surface cracking
- Reduced concrete cover and dead load.
- Improved surface quality and finishing.
- Reduced maintenance cost.
- General advantages of precast, permanent forms, as mentioned above.

6. FINAL REMARKS.

This proposal is “ an exercise of the mind”, based upon different kinds of experience during more than 35 years of work in the fields of construction materials and concrete technology.

There are a number of unanswered questions as to the technical and economical feasibility of the proposed method. It should, however, be tested in laboratory and full scale tests. It is hoped that the cement and concrete industry and the polymer industry will support a development program aiming at a pilot-plant study of the method.

Perhaps the large improvements in both strength properties and durability achieved by polymer impregnation in laboratory scale , could be utilized in full scale concrete structures.

APPROXIMATE ELASTIC MOMENT CALCULATION



Arne Hillerborg
 Professor Emeritus
 Folkungav. 11
 611 34 NYKÖPING
 SWEDEN

ABSTRACT

An simple iterative method is presented for the determination of support and span design moments, which are in an approximate agreement with the values according to the theory of elasticity. The method was developed in connection with an approach for the design by means of the Strip Method of irregular column supported slabs.

Key words: Bending moments, irregular slabs, column supported slabs, strip method.

1 BACKGROUND

In the *Strip Method Design Handbook* a method has been presented for the design of slabs resting on irregularly placed columns. In this method the slab is divided into elements, bounded by *support lines*, which are lines where the design support moments act, and *span lines*, which are lines where the design span moments act, and where the shear forces are assumed to be zero. At each such line the element shall in principle be in equilibrium with the adjacent element. At the same time it is desirable that the moments shall be close to those according to the theory of elasticity in order to ensure a suitable behaviour of the slab under service conditions.

In this case the static system is very complicated, as the elements have irregular shapes and a span line from one element often meets span lines from more than one other element. In order to make reasonably simple calculations possible an approximate approach for the moment determination has been used, which is believed to give moment values which are close enough to those according to the theory of elasticity.

As the *Strip Method Design Handbook* is intended to be a pure handbook for the practicing design engineer, the approximate method was given without presenting the background, on which it is founded. This background is presented below.

2 DESCRIPTION OF THE METHOD

In its basic form the method is only intended for slabs (or beams) with a constant depth. The extension to other cases will not be discussed here.

The analysis starts with assumptions regarding the approximate positions of the span lines (the support lines are determined by the positions of the supports and rules regarding directions). In a span between two columns or between a column and a wall where the slab is fixed the span line is assumed to be situated halfway between the supports. In a span between a column and a wall acting as a simple support the span line is assumed to be situated at a distance equal to $3/8$ of the span from the simple support.

Based on these span lines the total moment $M_f - M_s$ is calculated for each element (and reinforcement direction), where M_f is the span moment and M_s is the support moment (negative sign). Where two elements meet over a support the numerical value of the support moment is taken as $1/3$ of the sum of the total moments of the two elements (or between 0.30 and 0.37 of this sum, if there is a reason not to use exactly the factor $1/3$). Where the slab has a fixed support the numerical value of the support moment is taken as $2/3$ of the total moment in that element (or between 0.60 and 0.75 of this total moment).

When the support moments are known the corresponding span moments can be calculated for each element. Where two elements meet at a span line we get two values of span moments, one from each element. These two values should in principle coincide, which is not the case as a rule. In the *Strip Method Design Handbook* it has been proposed that a design span moment may be based on $3/4$ of the higher value plus $1/4$ of the lower value. This is believed always to give a safe design, provided that the difference between the values is not too great.

If the difference between the two values of span moments at the same span line is estimated to be too great, it is recommended to change the position of the span line and to repeat the calculation.

3 AN EXAMPLE OF THE APPLICATION

In order to demonstrate the practical application of the method the beam in Fig. 1 will be analysed. Span lines in slabs correspond to points of zero shear force in beams.

According to the rules given above the points of zero shear force will be assumed to be situated 4.0 m from A in span AB and 3.0 m from C in span BC.

The total moments in kNm in the four elements, calculated as $qc^2/2$, with c as the length of the element, are:

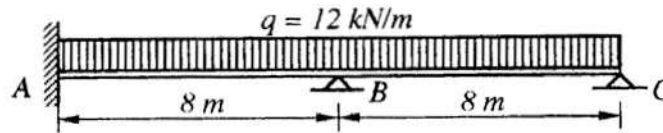

Fig 1

$$M_{AB} - M_A = 96, \quad M_{AB} - M_B = 96, \quad M_{BC} - M_B = 150, \quad M_{BC} = 54$$

where index A indicates the support moment M_s at A and index AB indicates the span moment M_f in span AB.

Applying the method we find one value for each support moment but two different values for each span moment

$$M_A = -64, \quad M_B = -(96 + 150)/3 = -82, \quad M_{AB} = 14 \text{ and } 32, \quad M_{BC} = 68 \text{ and } 54.$$

Applying the rule with 3/4 of the higher value plus 1/4 of the lower value we find design values for span moments

$$M_{AB} = 27.5, \quad M_{BC} = 64.5$$

As the difference between the two values of M_{AB} is rather high, a new calculation should be made after the point of zero shear force has been moved to the left a suitable distance, which according to the recommendations in *Strip Method Design Handbook* can be estimated to 0.4 m. We then find

$$M_{AB} - M_A = 77.8, \quad M_{AB} - M_B = 116.2, \quad M_{BC} - M_B = 150, \quad M_{BC} = 54$$

Applying the rules again we find

$$M_A = -51.9, \quad M_B = -88.7, \quad M_{AB} = 25.9 \text{ and } 27.5, \quad M_{BC} = 61.3 \text{ and } 54,$$

giving design span moments

$$M_{AB} = 27.1, \quad M_{BC} = 59.5$$

Further corrections of the positions of the points of zero shear force might be performed, but the values above are well acceptable. As a matter of fact the values from the first calculation may also be regarded as acceptable.

If the analysis is brought to a complete equilibrium the points of zero shear force are found to be situated 3.68 m from A and 3.11 m from C, and the corresponding moments are

$$M_A = -54.1, \quad M_B = -85.2, \quad M_{AB} = 27.0, \quad M_{BC} = 58.1$$

The differences from the values above are less than 5 per cent.

An analysis according to the theory of elasticity gives

$$M_A = -54.9, \quad M_B = -82.3, \quad M_{AB} = 27.9, \quad M_{BC} = 59.2$$

4 SOME SYSTEMATIC ANALYSES

In order to analyse how well the results of the approximate analyses agree with those according to the theory of elasticity some calculations have been carried through with a systematic variation of some factors which may be expected to influence the result.

In all the analyses the approximate method has been extended to a complete equilibrium, which in these simple cases can be made directly, without any iterations. The calculated design moments have been compared to the corresponding moments M_{el} according to the theory of elasticity

Figs 2 and 3 show the case of a beam with two equal spans, where the loads on the spans differ. In Fig 2 the outer ends of the beams are fixed, whereas in Fig 3 they are simply supported. The ratio between the acting loads varies between 1 and 3.

Figs 4 and 5 show the case of a beam in two spans with different lengths but with the same load per unit length. The ratio between span lengths varies between 1 and 1.6.

In evaluating the results it must be noted that M_A and M_{AB} are much smaller than the other moments in cases where the load ratio or the span ratio is high. Thus for the highest ratios in the diagrams M_A is less than 25 per cent of M_C and M_{AB} is less than 25 per cent of M_{BC} . Taking this into account the values according to the approximate method are close enough to the values according to the theory of elasticity to ensure a satisfactory behaviour of the structure under service conditions.

Reference:

Hillerborg, A. *Strip Method Design Handbook*. E & FN SPON, 1996.

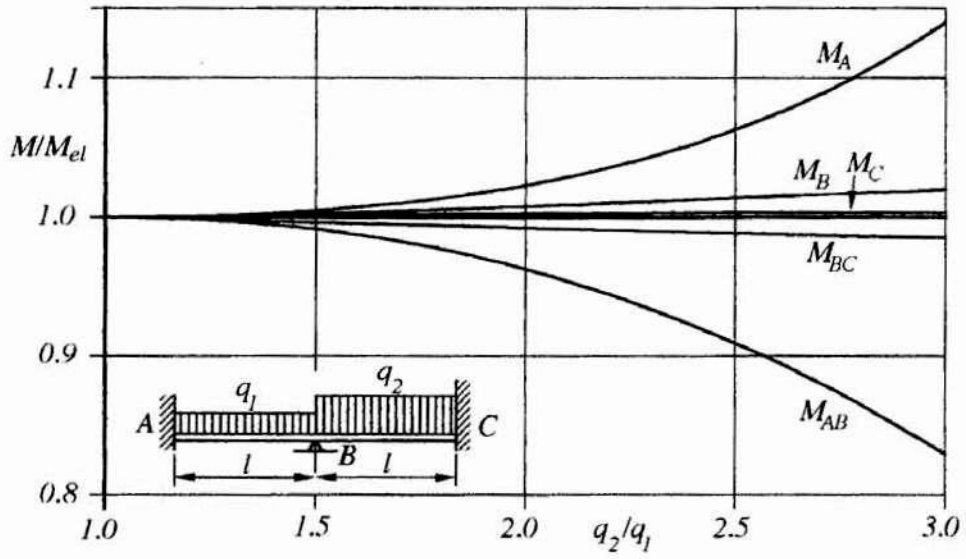

Fig 2

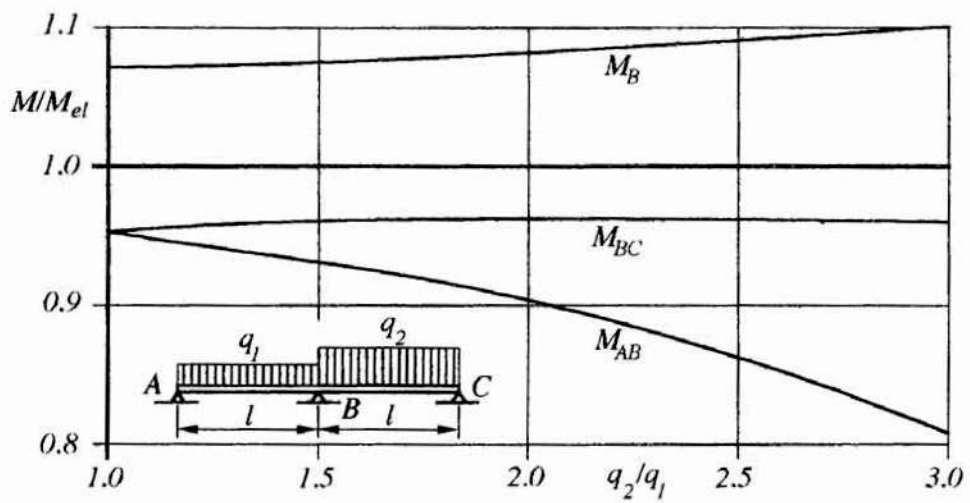

Fig 3

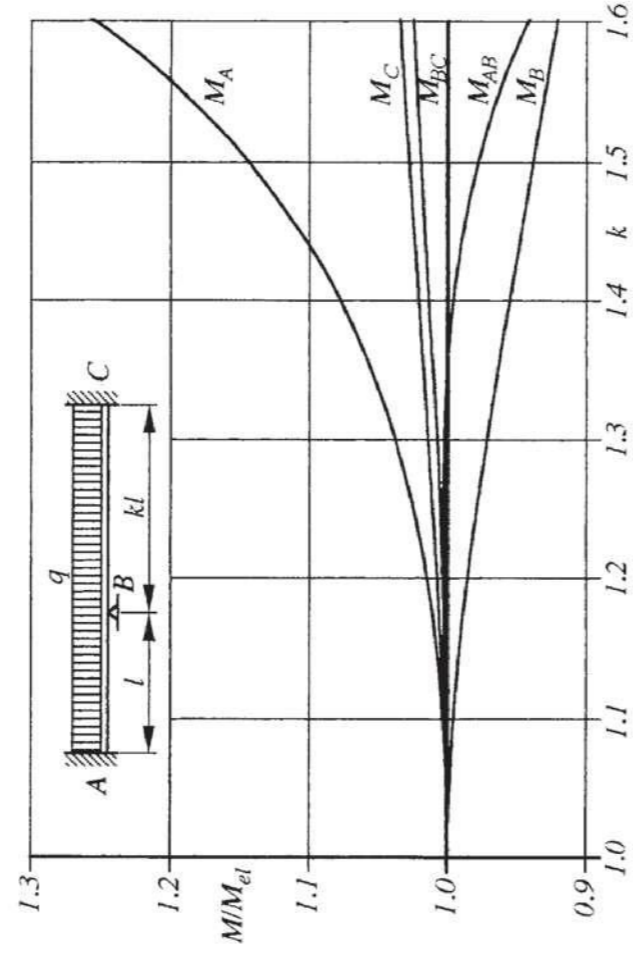

Fig 4

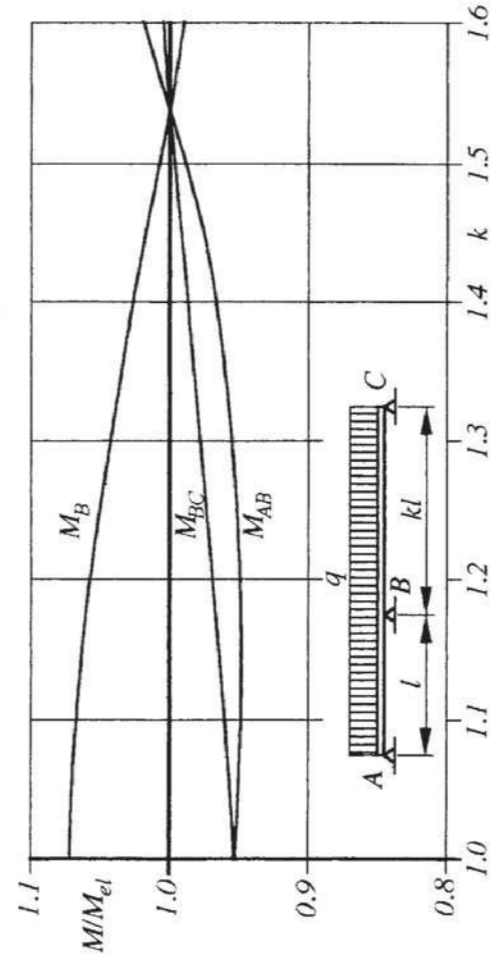

Fig 5

THEORETICAL CALCULATION OF EXPULSION TESTS



Jan-Erik Jonasson
 PhD. Associate Professor
 Division of Structural Engineering
 Luleå University of Technology
 971 87 LULEÅ
 SWEDEN

ABSTRACT

The basic equations for expulsion tests are given, and a normalized formulation suitable for numerical calculations are presented. A computer program called CYLPRESS has been shown to give stable and reliable results in calculating pressure-time field in a concrete cylinder.

Key words: Water expulsion, numerical method, permeability

1 INTRODUCTION

According to Fagerlund (1982) water expulsion tests may be used in determination of water permeability. Here a brief review of the equations in Fagerlund (1982) and a normalization of the equations as a base for numerical calculations will be given. Besides, a numerical solution of one case will also be presented briefly.

2 BASIC PRINCIPLE

Based on some findings in Vuorinen (1973) the use of a pressure-vessel to study both the air content and permeability parameters is refined and further developed theoretically by Fagerlund (1982). The principle of water expulsion is starting with a concrete specimen that has been put in water for such a long time that all pores except the compaction pores and entrained air-pores have become water-filled. The weight of the specimen after water storage is Q_0 [kg]. The specimen is then placed in a pressure vessel that is filled up with water and then closed. The water-pressure is increased from the initial value of 0.1 MPa to 15 MPa or more, i. e. an increase by a factor 150 or more.

Both the compaction and air-pores are gradually compressed by water that is forced into the specimen. After a certain time - normally less than 1 day - no further water intrusion occurs. The outer pressure is then released, which will cause a water expulsion from the specimen. By measuring the rate of the water expulsion and compare with calculated expulsion rates, we are able to determine the water permeability of the concrete.

The initial air-content, a_1 [m^3/m^3], before the pressure increase started is described by

$$a_1 = \frac{(Q_t - Q_0) / \rho_w + \Delta W_t}{V} \quad (1)$$

where Q_t [kg] is the weight of the specimen at a specified time - e. g 30 or 45 minutes - after the start of the water expulsion; ΔW_t [m^3] is the total water expulsion at the time specified for weighting; Q_0 [kg] is the weight of the specimen after water storage before it is placed into the pressure vessel; V [m^3] is the concrete specimen volume; and $\rho_w = 1000 \text{ kg/m}^3$ is the density of the water.

By using Boyle's law ($p \cdot a = \text{constant}$) for the air-volume and taking into account the expansion of the air-bubbles at variable pressure as well as the expansion of the bulk water, Fagerlund (1982) derived the following differential equation governing the pressure-time field in a concrete specimen

$$\frac{1}{K} \left(\frac{a_1 \cdot p_1}{[p(r,z,t)]^2} + \alpha \cdot k_1 \cdot \varepsilon \right) \frac{\partial p(r,z,t)}{\partial t} = \frac{1}{r} \frac{\partial}{\partial r} \left(r \frac{\partial p(r,z,t)}{\partial r} \right) + \frac{\partial^2 p(r,z,t)}{\partial z^2} \quad (2)$$

where K [m/s] is the permeability of the concrete; a_1 is the initial air-content, see Eq. 1; p_1 [Pa] is the environmental (final) air-pressure ($\approx 10^5 \text{ Pa}$ = "normal" atmospheric air-pressure); α is a correction factor (≤ 1) considering the effect of the compressibility of the concrete; k_1 [m^2/N] is the compressibility of the water ($\approx 4.7 \cdot 10^{-10} \text{ m}^2/\text{N}$); ε is the water-filled porosity; p [Pa] is the pore-water pressure; t [s] is the time parameter; r [m] and z [m] are the radius and the height coordinate of the concrete specimen, respectively.

Eq. 2 is governing a three-dimensional spatial situation for axisymmetric conditions including flow in the axial direction, see figure 1.

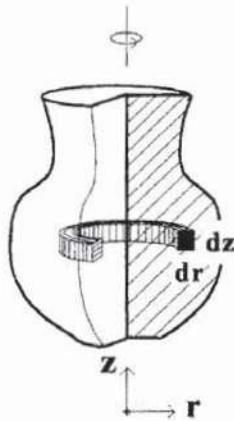

Figure 1

Illustration of the structure governed by Eq. 2, i. e. a spatial three-dimensional situation for axisymmetric conditions including flow in the axial direction.

The total water flow, dw [m^3], from the infinitesimal element ($dV = 2 \cdot \pi \cdot r \cdot dr \cdot dz$) at time t will (Fagerlund, 1982) be

$$dw(r, z, t) = (a(r, z, t) - a_0) \cdot dV \quad (3)$$

where $a(r, z, t)$ [m^3/m^3] is the air-content at a position described by the coordinates r [m] and z [m] at time t [s].

By integrating Eq. 3 and using Boyle's law ($p \cdot a = \text{constant}$) the total water flow from the entire specimen will be

$$\Delta w(t) = \int_V dw = \int_V a_1 \cdot p_1 \cdot \left(\frac{1}{p(r, z, t)} - \frac{1}{p_0} \right) \cdot dV \quad (4)$$

where $p(r, z, t)$ is the water-pressure at a position described by the coordinates r [m] and z [m] at time t [s].

For the use of a cylinder, see figure 2, in a pressure-vessel the start and boundary conditions are as follows

$$\text{At start, } t = 0: \quad p(r, z, 0) = p_0 \text{ for all } r \text{ and } z \text{ inside the specimen} \quad (5)$$

$$\text{At the boundary } : \quad p(\varnothing/2, L/2, t) = p_1 \text{ for all } t \quad (6)$$

$$\text{At the internal boundaries:} \quad \frac{\partial p(r, z, t)}{\partial r} = 0 \text{ for } r = 0 \quad (7)$$

$$\text{and} \quad \frac{\partial p(r, z, t)}{\partial z} = 0 \text{ for } z = 0 \quad (8)$$

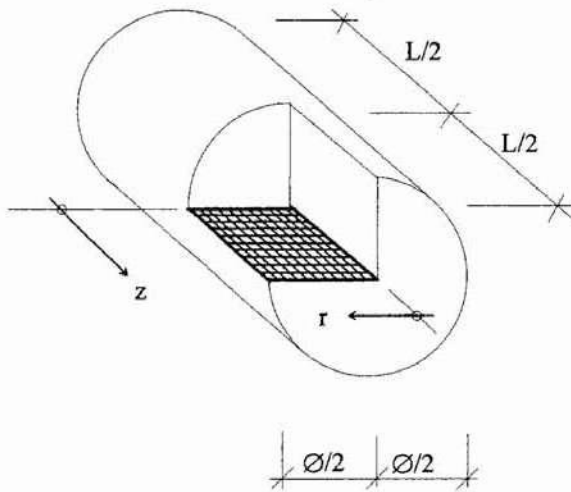

Figure 2

Illustration of choice of coordinates r and z for a cylinder with length L and diameter \varnothing with axisymmetric conditions. Due to symmetry only half the cylinder is analysed, which corresponds to a finite element discretization of one quarter of the cross-section through the rotational axis.

3 INTERESTING PARAMETERS AT EXPULSION ANALYSIS

The following parameters in Eq. 2 are stated (Fagerlund, 1982) to be interesting for numerical analyses:

$$p_0 = \{10, 12.5, 15, 17 \text{ MPa}\} \quad (9)$$

$$\varepsilon = \{0.12, 0.16\} \quad (10)$$

$$a_1 = \{0.01, 0.02, 0.04, 0.06, 0.08, 0.10\} \quad (11)$$

$$\alpha = \{0, 0.5, 1\} \quad (12)$$

4 NORMALIZATION OF THE BASIC EQUATIONS

To be able to do dimension-less calculations by Eq. 2 for the cylinder shown in figure 2 the following notations are introduced

$$\xi = \frac{r}{\varnothing} \quad (13)$$

$$\eta = \frac{z}{L} \quad (14)$$

$$\lambda = \frac{L}{\varnothing} \quad (15)$$

$$\tau = \frac{p_1 \cdot K \cdot t}{a_1 \cdot L^2} \quad (16)$$

$$\Theta(\xi, \eta, \tau) = \frac{p(\xi, \eta, \tau) - p_1}{p_0 - p_1} \quad (17)$$

$$\beta = \frac{\alpha \cdot k_1 \cdot \varepsilon \cdot p_1}{a_1} \quad (18)$$

$$\gamma = \frac{p_0 - p_1}{p_1} \quad (19)$$

which gives the following dimension-less normalization of Eq. 2

$$\left[\frac{1}{(1 + \gamma \cdot \Theta(\xi, \eta, \tau))^2} + \beta \right] = \lambda^2 \cdot \frac{1}{\xi} \cdot \frac{\partial}{\partial \xi} \left(\xi \cdot \frac{\partial \Theta(\xi, \eta, \tau)}{\partial \xi} \right) + \frac{\partial^2 \Theta(\xi, \eta, \tau)}{\partial \eta^2} \quad (20)$$

with the following start and boundary conditions, compare Eqs. 5 - 8:

At start $\tau = 0$: $\Theta(\xi, \eta, 0) = 1$ for all ξ and η inside the specimen (21)

At the external boundary: $\Theta(1/2, 1/2, \tau) = 0$ for all τ (22)

At internal boundaries: $\frac{\partial \Theta(\xi, \eta, \tau)}{\partial \xi} = 0$ for $\xi = 0$ (23)

and $\frac{\partial \Theta(\xi, \eta, \tau)}{\partial \eta} = 0$ for $\eta = 0$ (24)

5 RESULTING PORE-PRESSURE DISTRIBUTIONS

A computer program with the working name CYLPRESS has been developed by Jonasson and Stelmarczyk (1997) based on Eqs. 13 - 24. We want to check whether the calculations can be done with ordinary technique, which here means the use of the finite element method directly from start of the calculations without the use of any other numerical method, like Boltzmann's transformation at the very beginning. A calculation has been carried through, see figure 3, for the following situation:

$$\lambda = 3 \quad (25)$$

$$\gamma = 149 \quad (26)$$

$$\beta = 1 \cdot 10^{-4} \quad (27)$$

The situation corresponds to $p_0 = 15$ MPa for a cylinder specimen with $L = 0.3$ m and $\varnothing = 0.1$ m. With the parameters given in Eqs. 9 - 12 β will become between zero and $2.115 \cdot 10^{-4}$, which is fulfilled in Eq. 27.

Note that $\gamma = 149$ means that the left side of Eq. 20 at extreme cases (with $\beta = 0$) varies between $1/22500$ at the beginning and 1 at end of the calculations. In this case with $\beta = 1 \cdot 10^{-4}$ gives $1/6923$ at the beginning and near 1 at the end of the calculations.

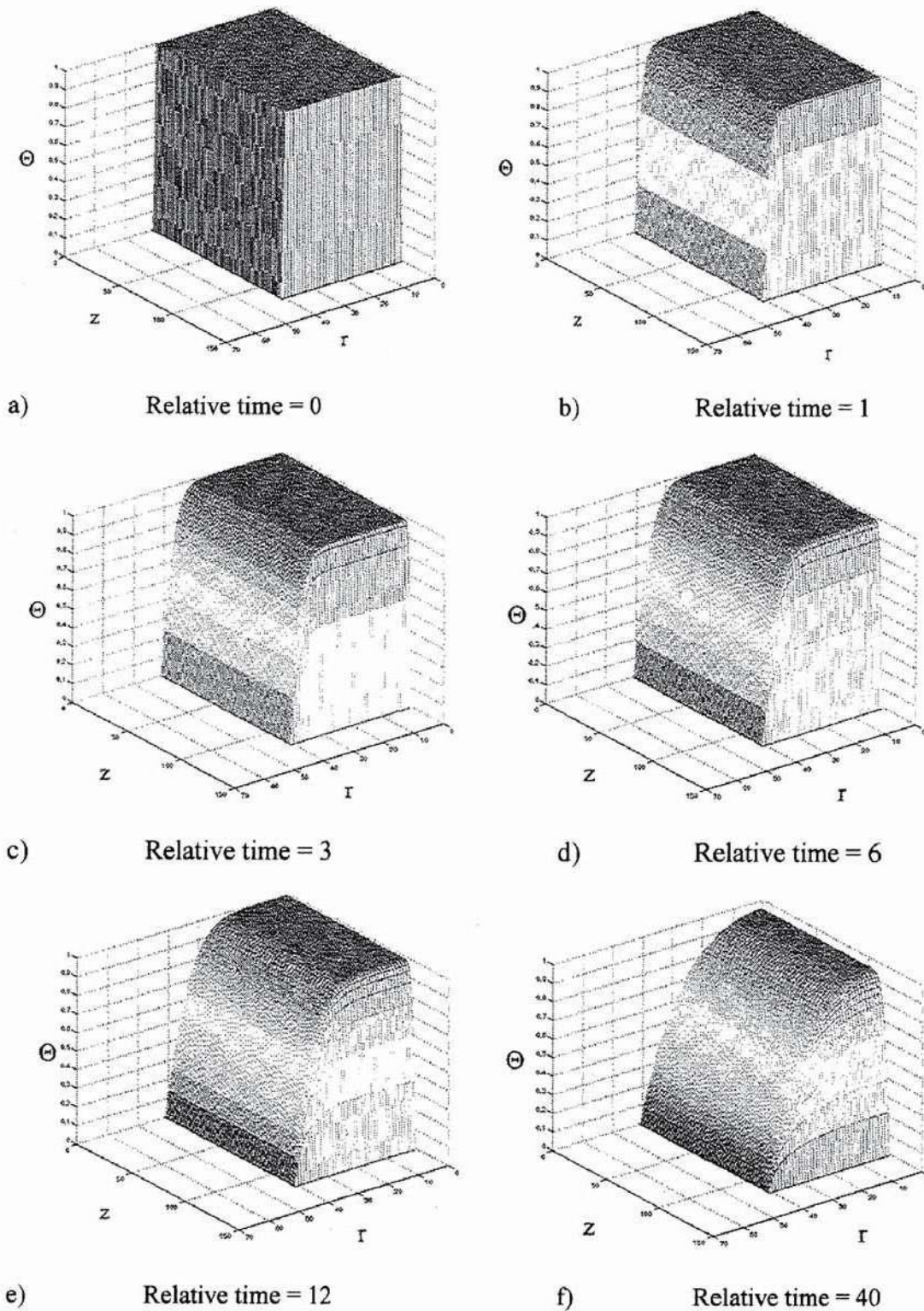

Figure 3 Calculated (with CYLPRESS) normalized pore-water pressure distributions at different relative times (a - f) for a section representing one quarter of a cylinder. One unit in relative time in the figure means $\Delta\tau = 250 \cdot 10^{-9}$.

So, in all realistic cases we have a highly non-linear problem to be solved numerically, which demands both small elements and small time steps in the calculations to get stable and reliable solutions, especially at the start of the calculations.

In the early 1980's some calculations were carried through according to Eq. 20 on a rather small personal computer, but reliable and stable solutions was not able to get at that time with reasonable execution times. Nowadays the personal computers have become very fast with high storage capacities, which makes the situation more inevitable in numerical solutions of Eq. 20.

Calculations done in 1997 with the computer program CYLPRESS are presented in figure 3 for some times. As can be seen in the figure, the solution looks very promising. Variations of time steps and element sizes have shown that the solution is stable, which indicates that the true solution is found.

6 CONCLUSION

The recently developed computer program CYLPRESS (Jonasson and Stelmarczyk, 1997) gives stable solutions of the differential equation governing the pressure-time field at expulsion of water from a cylinder. This means that we now have possibility to calculate the amount of water at expulsion from a cylinder by numerical integration from calculated pressure-time fields in a spatial three-dimensional specimen. With data from "traditional" permeability tests for calibration of calculated flow depending on the permeability, water expulsion tests might be established as a method for determination of permeability in concrete in the future based on the equations given in Fagerlund (1982).

7 REFERENCES

Fagerlund G (1982): Test of the water permeability by the water expulsion method. Hand-written manuscript to the Cembureau Permeability Group, Cements AB, Stockholm.

Jonasson J-E and Stelmarczyk M (1997): Test of computer program CYLPRESS - an ongoing development and testing of computer programs for solutions of non-linear flow equations, JEJMS Concrete AB, Luleå.

Vuorinen J (1973): On determination of effective degree of saturation of concrete. Manuscript. Concrete and soils laboratory - Imatran Voima Oy, Finland.

ASPECTS ON THE CONTROL OF FROST RESISTANCE OF CONCRETE



Heikki Kukko
 DTech, Research Professor
 VTT Building Technology
 P.O.Box 1805
 FIN-02044 VTT
 FINLAND

ABSTRACT

The control of frost resistance of concrete has got new challenges due to the changes of materials and especially because the strength e.g. in precast facade elements has increased. The variation of frost resistance of non-air entrained high strength concretes stresses the need to develop methods for frost resistance control. The beneficial effect of low water/binder ratio should be taken into account but the tendency for high variation in frost resistance has to be managed at the same time if no air entrainment is used.

Key words: Concrete, frost resistance, testing, quality control, high strength

INTRODUCTION

Lack of frost resistance has been a major cause of widespread damage to concrete structures. Studies on concrete frost resistance have been performed ever since the early 19th century.

The methods of quality control differ from country to country. There are several requirements for a good quality assessment system. The methods and the whole system have to be

- valid: the method should correlate with practical deterioration processes
- reliable: the methods have to be able with a reasonable probability to distinguish between acceptable and poor quality.
- rapid: the results should be available prior to erecting the structure. If this is not the case and quality assessment system is mainly based on preliminary tests, the system should have a solid theoretical base.
- economical: the cost of testing should be low enough to allow reasonably high testing frequency
- easy to perform: tests that are easy to understand and can also be made at plant laboratories are ideal

- able to deal with cases of doubtful quality

Basically the quality assessment should also have a sound theoretical basis. This is why a short summary of the theories is presented in the following.

THEORIES OF FROST RESISTANCE

Frost deterioration of concrete consists of very complicated phenomena. Over 15 theories and explanations of concrete frost resistance or the lack of it are presented in the literature /1/. The main theories are briefly presented below.

The theory of hydraulic pressure is one of the oldest and most often applied theories of frost resistance. Probably the main reason for its common use is its illustrative character and easiness. The first presenter of this theory, T.C. Powers, already stated that this theory alone is not capable of explaining frost defects of concrete /2/. According to him, also diffusion phenomena affect the degree of frost damage.

The basic assumption of the **theory of hydraulic pressure** is that disruption of concrete is caused by the expansion of water during freezing. The expansion, which is roughly 9%, causes hydraulic pressure in the pores of concrete. When water freezes in a capillary pore filled with water, part of the unfrozen water has to be expelled from the pore.

Generally it can be said that the destruction of concrete subjected to repeated freezing and thawing is not fully understood. One could say that the theories usually give reliable results only with the concretes and circumstances from which they are derived. The main factors affecting the frost resistance are nevertheless the porous structure of the concrete, its water content, temperature changes and possibly the effect of deicing and other salts.

The effect of salt concentration of the environmental water and pore solution, as well as freezing rate, minimum temperature and type of binder cause changes in the applicability of various explanations. The aim of this paper is not to concentrate on the accuracy of these theories, but to elucidate the problems in experimental measuring of frost resistance. This theory and equations based on it have been found to correspond relatively well to the practical results with medium strength concrete. The exact frost resistance depends considerably on e.g. the real freezing temperatures of pore water, pore shapes, and statistical distribution of porosity and strength properties of concrete on the microscopic scale.

The theory of crystallization pressure of ice was first described by Collins /3/, who found some similarities in the frost disintegration of low quality concretes and frost heave of soils and based his theory on these findings. According to the theory, one basic factor in the formation of ice is the ice crystals in contact with water growing parallel to the direction of heat flow, and not necessarily in the direction of least

resistance. The crystals continue to grow as long as water is available or until the pressure reaches a point at which freezing is inhibited. This pressure increases as the temperature falls and its direction is that of the ice crystals formation, that is, normal to the cold surface.

The theory of ice lens formation, first presented by Everett /4/, is basically developed from and supported by the fact that damage to porous solids by freezing is not necessarily directly related to the expansion that occurs when water freezes. Similar damage to stone and consolidated earth has also been said to result from the freezing of organic liquids with freezing contraction /5/.

The basic idea behind this theory is closely related to the crystallization pressure theory. The ideal model for material structure is one with coarse pores separated by micro-porous regions. Upon cooling of the water saturated material, ice crystals tend to form from the supercooled water in all pores. Ice crystals in the smaller pores are limited to their pore sizes. Once a difference in size has been established between crystals in the small and large pores, the larger crystals will "feed" on the smaller ones until the coarse pore space is filled. After this, further growth tends to proceed against the constraint imposed by the walls of the pore and may lead to mechanical failure of the pore structure.

Theory of osmotic pressure: When solutions of different concentrations of soluble materials are separated by a permeable barrier, the solvent particles move through the barrier towards the solution of greater concentration and a differential head is set up between the two solutions. This osmotic action increases the hydraulic pressure in cement paste as freezable water is forced from the capillaries into the gel pores.

The water in capillary pores contains a concentration of salts. This increases as the water begins to freeze, and the water being forced from the capillaries has a higher concentration of salt than the surrounding gel pore water. A pressure differential develops to overcome osmotic pressure in the capillary, which is a combination of the hydraulic pressure required to force capillary water into the gel pore structure and the osmotic pressure which resists this flow. This mechanism has been suggested especially as a possible cause of scaling of concrete pavements where salt is used.

Thermal incompatibility of concrete components: Unequal volume changes of concrete components due to temperature fluctuations cause stresses in concrete. These stresses may reduce concrete durability if coefficients of thermal expansion of aggregates and hardened cement paste, or other components, differ too much, and if the temperature changes are large enough. Cycling of temperature may cause fatigue failure. This mechanism has been studied mathematically using the finite element method. The results in e.g. /6/ and /7/ show that even in dry conditions serious damage can take place in concrete. Severe damage is in apparent conflict with calorimetric results showing only small amounts of freezable water in concrete.

Other theories mentioned in the literature /1/ are based e.g. on

- the water migration through porous media in its contact zone with ice
- the increase of viscosity squeezed out by ice
- migration of water in the steam phase
- the filling of pores and other cavities with water films
- the disintegrating action of thin water films

Various theories explain the modes of deterioration. Most of the frost resistance theories are based on freezing of water and its moisture movement in concrete. The result of hydraulic pressure increase is formation and growth of cracks and coarsening of pore structure. This should be observable with porosimetric methods and thin section analysis. Crystallization pressure of ice, osmotic pressure and formation of ice lenses should cause cracking to develop mostly parallel to the concrete surface. Thermal incompatibility causes cracks to develop in the concrete especially near the aggregate surfaces. This degradation mechanism thus increases cracking but does not change pore size distribution. Cracking may be perpendicular or parallel to the aggregate surface.

The large number of theories points to the complexity of the phenomenon and most likely to the impossibility of a single explanation. Assumably there is no single cause for frost damage. Closest to one universal clarification is the explanation of freezing and thawing behavior in terms of factors directly associated with the porosity of the matrix, e.g. in concrete. This aspect seems to be the most important, but leaves unexplained several phenomena related to the considerable influence of concrete composition, granulometry and properties of aggregates, their shape etc. These effects have been demonstrated in several experimental studies. The effects of original pore structure and other properties of concrete have been widely studied, but papers dealing with frost effects on e.g. mercury porosimetry curves are scarce. Studies on porosity changes have been done by Huang et al./8/, Pigeon and Regourd /9/ and Kukko /10/.

DETERMINATION OF FROST RESISTANCE FROM CRITICAL DEGREE OF SATURATION

The theory of frost resistance determination based on the critical degree of saturation was proposed by Fagerlund /11/. The degree of saturation is the volume of pores filled with water divided by the total pore volume. Fagerlund has shown that a porous material is damaged upon freezing only if its water content is higher than a given critical degree of saturation S_{cr} . The value of S_{cr} varies with material type and quality.

S_{cr} alone is not a measure of frost resistance. It must also be known how much water the material will contain in practice. This latter condition is termed actual degree of saturation, S_{act} . However, it is only a function of environmental factors for a given material.

Hence according to Fagerlund, a suitable definition of freeze-thaw resistance is the difference between S_{cr} and S_{act} . In principle it is possible to calculate the value of S_{act} with the help of advanced moisture mechanics. In practice, however, this is not a simple task. In many cases the environmental conditions correspond to many days of water uptake in the specimen. In these cases Fagerlund replaces S_{act} by the capillary degree of saturation S_{cap} which is determined by a water uptake test. S_{act} versus time is approximated as linear in a logarithmic time scale.

One of the main benefits in the theory of critical degree of saturation is that it takes into consideration the environmental conditions of the concrete structure and, when the climatic conditions are known, the slow and even stochastic nature of the frost effect. In this way it serves well also the goal of service life design

CURRENT TRENDS

On the Nordic level there seem to exist varying impressions on the practical state of the real frost resistance of structures. The opinions in this paper are the author's views and do not necessarily agree with the postures of VTT Building Technology. The main attention is given to the frost resistance without salt action.

The frost resistance of bridges seems to be much better mastered than that of concrete facades. Especially in Finland the durability of concrete facades is anticipated to cause major repair costs in the future. The cost of facade preparations is estimated to be around 900 million USD in the next 10 years in Finland. The situation does not seem to be this serious in the other Nordic countries. One reason for the inferior frost resistance in many of the precast element facades has been the fluctuating production volume with high temperature heat treatment and insufficient quality control in the 1970's. In the other Nordic countries the more stable volume and bigger share of in-situ construction have probably led to a more favourable result.

The main problem now is how to assure the quality of the facades produced today. An attempt to extend the service life of concrete facades was made during the renewal of the Finnish durability guidelines for the concrete structures in 1992 /12/. This was made by increasing the strength level up to 45 MPa cubic strength from the earlier mainly used 30 MPa level. At the same time the porosity requirement, so called "protective pore ratio" (SFS 4475) was decreased from the common value of 0.2 to 0.17 for concretes with strength above 40 MPa. As a result, most of the new precast element facades seem to have a very good frost resistance. However, other problems arose. Cracking of the facade surfaces increased and caused mainly aesthetic troubles. The bond of clinker tiles on concrete facades was in several cases inadequate. Both of these problems seem to have the increased shrinkage as well as the surface hardness as main reasons. These troubles were to some degree expected, but obviously underestimated. The third and unexpected problem, that probably had the higher strengths as partial reason, was the sometimes observed instability of pore structure in

concrete. One manifestation of this was that the air content was as planned, but the pore size distribution may have been much too coarse. In some cases the air content and porosity was not found satisfactory in the produced elements, even if preliminary tests and air content measurements of the mix were normal.

These changes and problems have caused a new "renaissance" of frost resistance as topic of interest in Finland. The main questions have been:

1. Do we need air entrainment in high strength concrete?
2. If we need air entrainment, how can we be sure that we have it in the element?

The effectiveness of air entrainment has been well demonstrated in the old concrete facades with medium strength, e.g./13/. An open question is, are these results to be directly adapted to modern concrete with higher strength, byproducts, admixtures and varied cements. The combination of 45 MPa strength and air entrainment is exceptionally hard for facades and not usually required in other countries. This is why questions have been made about the justification of these strict quality requirements. The main target has been in compensating air entrainment by the higher strength level. It is, however, not properly known, what are the strength limits for adequate frost resistance with modern concrete technology.

The issue of frost resistance of non-air entrained concrete has been studied mainly with high strength concrete. The medium strength concretes of 40 ... 50 MPa have not got such an interest. The results of the Finnish studies with 80 MPa concrete can be summarized as follows /14/:

- high strength leads in by far most cases into very good frost resistance
- small differences in non-air entrained high strength concretes cause considerable variation in frost resistance and the frost resistance in individual cases may be inferior
- small and coincidental differences in air contents may have significant effect on frost resistance.

In this way it can be stated that even if the frost resistance on the average is very good and would support the use of high strength concretes in severe environment without air entrainment, there are problems due to the variation of frost resistance. The limit for water/binder-ratio, under which frost resistance seems to be always good in "ordinary" concretes, is according to /14/ and /15/ as low as about 0.30 or 0.32 respectively. The value of 0.32 is used in the Finnish bridge building regulations of the Finnish Road Administration.

The main practical problem in utilizing the increase of frost resistance with increasing strength is distinguishing those concretes not following the general rule: high strength (low w/c) => good frost resistance. At the moment there seems not to exist enough experience and information to conclude from the materials or mix proportioning if a concrete mix belongs to the risky ones. In order to have this information heavy (compared to normal testing) freeze-thaw testing is done, where these concretes are used.

As a conclusion, the testing methods should be developed in order to be applicable with higher strengths and lower water/binder ratios. There are several reasons why this should be done:

- Capillary suction is very low with low w/c, which makes the estimation of the "nick point" in capillary suction test or total capillary porosity in protective pore ratio test in practice difficult to measure.
- The usual requirements in indirect tests are on the safe side and do not take into account the low porosity and permeability of the concrete. As an example, the thin section analysis has been used to assure that air porosity in 40...50 MPa concrete is adequate. However, it would be a mistake to take limits for specific surface area of pores and spacing factor directly from Canadian or ASTM standards, because those limits are set more than 30 years ago for concretes with strength level around 25 MPa. The very much lower capillarity nowadays leads to somewhat lower requirements for the same and even higher frost resistance.
- The use of dilation tests has become actual again, because they elucidate the behavior of concrete in a more direct way than porosity or microscopy. For relatively high strength facade concretes and other outdoor concretes without salt action, the acceptance limits should be checked.
- The thin section analysis seems to be a valuable tool in checking the real air pore structure in air entrained concretes. However, the acceptance limits, intra- and interlaboratory variances and test frequencies should be checked.

There are parallel triennial projects started in 1997 at VTT Building Technology and Helsinki University of Technology to develop practical quality control of concrete frost resistance and, on the other hand, the theoretical modeling of frost resistance of concrete. The issues mentioned above will be, at least partly, studied in these projects.

LITERATURE

/1/ Podvalnyi, A. M. 1976. Phenomenological aspect of concrete durability theory. *Materials and Structures* 9, 51, pp. 151 - 162.

/2/ Powers, T. C. & Helmuth, R. A. 1953. Theory of volume changes in hardened Portland cement paste during freezing. *Proceedings, Highway Research Board* 32, 5, pp. 285 - 297.

/3/ Collins, A. R. 1944. The destruction of concrete by frost. *Journal of the Institution of Civil Engineers*. 23, 1, pp. 29 - 41.

/4/ Everett, D. H. 1961. The thermodynamics of frost damage to porous solids. *Transactions of the Faraday Society*. 57, pp. 1541 - 1551.

/5/ Taber, S. 1929. Frost heaving. *Journal of Geology* 37, 5, pp. 428 - 461.

- /6/ Venecanin, S.D. 1983. Stresses in concrete due to the thermal incompatibility of its components. *Int. Coll. Material Science and Restauration*. Essingen, Germany. Pp. 93 - 98.
- /7/ Huovinen, S. 1990. Abrasion of concrete by ice in arctic sea structures. Espoo, Technical Research Centre of Finland, Publications 62. 110 p. + app. 31 p.
- /8/ Huang, Y., Ding, W. & Lu, P. 1985. The influence of pore-structure on the compressive strength of hardened cement paste. *MRS Symp. Very High Strength Cement-Based Materials*. Boston, 27 - 28 Nov. 1984. Pittsburg, Materials Research Society, Symp. Proc. 42. Pp. 123 - 131.
- /9/ Pigeon, M. & Regourd, M. 1986. The effects of freeze-thaw cycles on the microstructure of hydration products. *Durability of Building Materials* 4, 1, pp. 1 - 19.
- /10/ Kukko, H. 1992. Frost effects on the microstructure of high strength concrete, and methods for their analysis. Espoo, Technical Research Centre of Finland, VTT Publications 126. 133 p. + app. 44 p.
- /11/ Fagerlund, G. 1977. The critical degree of saturation method of assessing the freeze/thaw resistance of concrete. *Materials and Structures* 10, 58, pp. 217 - 229.
- /12/ Betonirakenteiden säilyvyysohjeet ja käyttöikämitoitus 1992 (Durability guidelines and service life design for concrete structures 1992). Concrete Association of Finland. Publication by 32. Helsinki 1992. 66 p. (In Finnish)
- /13/ Pyy, H. 1996. The influence of air-entraining and other microstructure properties on the resistance of concrete - a case study. *Frost resistance of building materials*. Universtiy Lund.
- /14/ Kukko, H. & Tattari, K. 1995. Korkealujuusbetonien säilyvyys (Durability of high strength concrete). Espoo, Technical Research Centre of Finland, VTT Julkaisuja/Publication 808, 33 p. + app. 25 p. (In Finnish with English abstract)
- /15/ Kukko, H. & Matala, S. 1991. Effect of composition and aging on the frost resistance of high-strength concrete. *2nd Int. Conf. Durability of Concrete*. Montreal, Canada. Detroit, MI 1991, American Concrete Institute, ACI Publ. SP-126. Vol. 1. Pp. 229 - 244.

THE DEVELOPMENT OF THE USE OF SILICA FUME IN CONCRETE IN NORWAY



Magne Maage
Professor
SELMER ASA
P.O. Box 6033
N-7003 Trondheim
Norway.

ABSTRACT

The development of use of silica fume in concrete in Norway started in the late 1940-ties. However, the commercial use was not a reality until the ending of the 1970-ties. The first years silica fume was used as an almost cost free material replacing cement while fulfilling the strength requirements. This has changed over years and today the main application is for improving properties both in fresh and hardened state.

The paper will give a review of the development of the use of silica fume in concrete in Norway, showing how the typical application has changed over time. Also the requirements in the Norwegian Standards and the Directorate of Public Roads will be reviewed.

Key words: Silica fume, application, historical development, standards, codes.

1 INTRODUCTION

1.1 Silica fume

Silica fume is a kind of fly ash from the production of Si-metal or Fe-Si-alloy. It consists of 85-96 % amorphous SiO_2 with an average particle diameter of about 0,1 μm which is about a hundredth of that of cement. The surface area of silica fume is normally about 20 m^2 per gram compared to about 0,4 m^2 for cement.

Silica fume has two principle effects when used in concrete, a chemical and a physical effect.

1. The chemical effect is typical pozzolanic due to the high content of amorphous SiO_2 and the extremely small particles. $\text{Ca}(\text{OH})_2$ from the water-cement reaction is consumed changing it to C-S-H-products which results in stronger and tighter concrete.

The chemical reactions are relatively fast and are finished after a month at normal temperatures and dosages.

2. The physical effect is a typical filler effect due to the small particles which will fill in between larger particles like cement. The high surface area will reduce bleeding and result in a more stable concrete in the fresh state.

1.2 Short history

Research with silica fume in concrete started in Norway at the end of the forties. The fume was collected by using wet burlaps over the chimneys. Parts of the research was published in the early fifties. At that time no plasticisers were used, but some very positive effects were found. No research on silica fume was undertaken during the following years up to the seventies. In the seventies the cleaning of the combustion gases started due to protection of the environment and abundant quantities of silica fume became available. At that time it was a waste material delivered free and the research took off again both in Norway and subsequently in the rest of the world. At the beginning it was used as a cement replacement in relatively low-strength concretes. This has changed and it is today mostly used as an efficient material to improve concrete properties both in fresh and hardened state.

1.3 Consumption of silica fume in Norway

The consumption of silica fume in concrete in Norway has been relatively stable at around 20 000 tonnes per year the last years, while the corresponding figure for cement is around 1,2 million tonnes. This latter figure include different types of ordinary portland cement and a blended cement with 20 % fly ash by weight of cement. This means that more than 30 % of all the concrete produced in Norway today contain an average of 5 % of silica fume. The use of silica fume is very common mainly due to the improved properties it gives to the concrete, and partly due to the easy availability, the relatively low price (ranging from 100 to 200 % of that of cement), the traditional extensive use of plasticisers and the early research on silica fume.

Silica fume used to be a waste material. However, today one of the factories in Norway is operating with the main purpose of producing a white fume for special purposes. This is more expensive than normal grey silica fume.

2 SILICA FUME AS A WASTE MATERIAL

The commercial use of silica fume started in Norway in the late seventies. At that time the fume was a waste material delivered free or very cheap to the concrete producers. The only requirement on concrete at that time was compressive strength. Other properties like durability was not a topic. Around 65 - 70 % of the concrete production was grade C25 (25 MPa characteristic cube strength) and 3 - 4 parts of cement were replaced by one part of silica fume by weight. The concrete producers saved a lot of

cement and money without doing anything illegal according to the standards in force. The requirement on normative (28 days curing in water at 20°C) compressive strength was fulfilled. In such concretes the w/(c+s) ration was in the range of 0,90 - 1,00.

By using such a concrete in practical application, it was found that the early strength, especially at low temperatures, was much lower than the contractors were used to. This resulted in some situations in longer periods with the formwork on, and the capacity was reduced. Even some accidents happened due to too early stripping of the formwork.

Plastic shrinkage became a common problem at that time due to the reduced bleeding and the fine structure, resulting in higher surface stresses in fresh concrete with silica fume. This problem was generally more extensive in concrete with low w/c-ratios than in that of higher.

The use of silica fume in the late seventies and the early eighties as a strength gaining material in low strength concrete, started a discussion on durability. One part of the concrete experts claimed that even a concrete with as high a w/c-ratio as around 1,00 would produce a durable concrete due to the tightening effect of the silica fume. Another part of the experts meant that such concretes had very poor durability properties. The dispute was mostly oral, but some times very close to physical fight between the two parts.

This discussion in the early eighties resulted gradually in other requirements to the concrete than strength only, as discussed in chapter 4. Partly due to this, the application of silica fume in Norway changed quite a lot during the late eighties.

3 SILICA FUME AS A QUALITY IMPROVING MATERIAL

As knowledge on the benefits of proper use of silica fume increased and documentation became available during the eighties and nineties, silica fume became more expensive and regulations in standards and codes favoured a more high technology application. This development has continued also in the nineties and it is applicable both for fresh and hardened concrete.

3.1 Fresh concrete

In the fresh state, silica fume is used to make a more stable concrete with reduced voids. This is favourable in order to produce a higher quality concrete with less bubbles in the surfaces. However, if the silica fume content is too high, the concrete will be sticky and difficult to work with. This can partly be overcome by additional quantities of superplasticisers. A normal dosage of silica fume today is around 5 % by weight of cement, which means that the stabilisation effect is achieved without running into any problem with stickiness.

Stickiness is sometimes wanted, especially in the wet process method shotcreting. High stickiness makes it possible to produce thicker layers in one operation without falling off or sagging of the concrete. The silica fume content in shotcrete is therefore normally somewhat higher compared to that in normal concrete.

In underwater concreting, higher stability is wanted than in normal concrete in order to reduce the risk of wash out of the concrete. This means a higher dosage of silica fume than normal. However, the stickiness is not wanted and higher dosages of superplasticisers are used to compensate. Even in mixes with anti wash out admixtures, it is necessary with silica fume, but the content is normally reduced somewhat.

In concrete with silica fume and especially at low w/c-ratios, the risk of plastic shrinkage cracking is higher than in concrete without. In order to reduce the risk, the protection and curing of low w/c-ratio silica fume concrete have to start immediately after pouring.

3.2 High strength concrete

High strength concrete is achieved by optimising the constituent materials and the volume composition of them. It is not always necessary with silica fume to produce high strength concrete, but it is a convenient way of keeping a defined strength without stressing the optimising of the other factors. When all factors are optimised, the use of silica fume will increase the strength even more.

Due to reduced bleeding, the bond between aggregates and paste will be improved, resulting in higher tensile and flexural strength.

It has been erroneously claimed that silica fume will result in a more brittle material. However, silica fume itself will not influence brittleness, but it will increase strength. Concrete becomes more brittle with increasing strength regardless of how the strength is achieved.

3.3 Durability

Durability of silica fume concrete has been under intense discussion for many years. Today, most experts agree on the most important issues.

From a durability point of view, silica fume has at least two main effects. Due to the chemical and physical effects discussed earlier, the concrete will be tighter against ingress of harmful agents. Also the chemical activities will be reduced because the pozzolanic reaction has reduced the content of Ca(OH)_2 . It has been found that silica fume concrete has somewhat more microcracks than concrete without silica fume. However, the effect of microcracks on durability is not clear. Ultimate drying shrinkage seems not to be influenced by silica fume.

Generally speaking, frost resistance is improved by adding silica fume to the concrete. This was demonstrated in the initial tests in the late forties and has been confirmed in newer tests, although controversial results have been reported.

Resistance against chemical agents is improved both due to tighter concrete and reduced content of $\text{Ca}(\text{OH})_2$. Alkali silica reactions are prevented by silica fume. This is the reason why silica fume is added to the cement in Iceland and some other countries.

The most intense discussion has been on the effect of silica fume on reinforcement corrosion. Reinforcement corrosion has to be divided into the initiation and the propagation period. In the first period, no corrosion has started, but the carbonation and/or chloride ions are penetrating into the concrete. Corrosion may start when the carbonation has reached the steel or the chloride content at the steel surface has passed the threshold value.

Carbonation seems to penetrate faster into concrete with silica fume compared to concrete without when the w/c-ratio is higher than around 0.70. However, at lower w/c-ratios, no negative effect of silica fume is observed.

The rate of chloride penetration into concrete is essentially reduced by silica fume which means that the initiation period will be much longer. However, it is possible that the threshold value is somewhat reduced due to the fact that silica fume will reduce the pH-value somewhat. The first effect is, however, dominating over the second.

The propagation period is governed by the electrical resistivity in the concrete and the oxygen transport through the concrete. At a constant degree of water saturation in the concrete, the electrical resistivity is reduced considerably leading to slower corrosion rate when silica fume is used. Oxygen diffusion through saturated concrete seems not to be influenced significantly by the use of silica fume. In unsaturated condition, there are lack of data.

As a conclusion for the effect of silica fume on reinforcement corrosion, both negative and positive factors have been found. However, the positive effects are dominating strongly over the negative, which means that resistance against reinforcement corrosion is strongly improved by using silica fume in the concrete.

4 REQUIREMENTS IN NORWEGIAN STANDARDS AND REGULATIONS FROM THE DIRECTORATE OF PUBLIC ROADS

When the commercial use of silica fume started in the late seventies, the concrete material standard NS 3420 from 1973 was in power. This is the most liberal standard we have ever had in Norway from a durability point of view. Compressive strength was the most important property. Everything was optimised in order to reach the formal strength requirement. No requirements on durability parameters were defined

for any exposure classes. This standard inspired the concrete industry to optimise materials and mix proportion from a strength point of view, and silica fume came at the right time. This was the reason why silica fume at the beginning could be used as a strength gaining material in all strength classes.

The requirements in the regulations from the Directorate of Public Roads (DPR) were close to those of NS 3420 at that time. However, DPR was conservative and did not allow the use of silica fume, even not as a quality improving material. This situation was not changed in the revised code from 1981. During the eighties, DPR slowly changed their mind.

As a result of the durability discussion in the late seventies and the early eighties, a circular was issued from the Norwegian Council for Building Standardization (NBR) in 1982, partly regulating the use of silica fume. It was, among other things, pointed out that the SiO_2 content should be higher than 85%, the dosage of silica fume should not be higher than 10% by weight of the clinker part of the cement and the $w/(c+k \cdot s)$ -ratio should not be higher than 0,70 in reinforced structures. The efficiency factor k should normally be 1,0, but other values could be used if it was documented that the performance properties of the concrete were not reduced. During setting and hardening, special care should be taken to avoid plastic shrinkage and to give sufficient curing.

The implication of this was that the production of low strength concrete with extremely high w/c -ratios was not possible any more.

NS 3420 was revised in 1986, covering requirements on materials and execution of concrete works. Durability requirements were introduced, related to environmental exposure classes. The «mass-factor» m was calculated as $m = w/(c+k \cdot s)$. The requirements in the 1982-circular were adopted in NS 3420. However, limiting values for m were introduced depending on environmental exposure. For structural concrete these limiting m -values were 0,45 and 0,60.

The implication was that there were no longer economic reasons for using silica fume in low strength concrete because strength is normally high enough due to durability requirements.

The standard from 1986 is still valid. A revision is going on, but the requirements for the use of silica fume seems to be unchanged.

DPR's regulations were revised in 1988. Formulations from NS 3420 were copied for the greater part. However, the philosophy in NS 3420 is a service life of 50-60 years compared to more than 100 years by DPR. This means some stricter requirements on the m -values: 0,40 and 0,50 where NS 3420 had 0,45 and 0,60 respectively. In these regulations, DPR has changed their mind and require that silica fume **shall** be used at an amount of 2-5% by weight of cement with up to 10% fly ash in the cement. The efficiency factor k for silica fume shall be set equal to 2,0 when calculating the mass

factor m . This means that higher priority was given to silica fume compared to recommendations in NS 3420 due to the fact that the main durability problem for bridges is chloride intrusion.

A standard (NS 3045) for the material silica fume was issued in 1992. This standard is also the base for a CEN-standard on silica fume. The main requirements are on SiO_2 content, loss of ignition, chloride content, free calcium oxide, specific surface and activity index.

DPR's regulations were revised again and issued this year. Some new details were introduced, but the main requirements are as earlier. A stricter exposure class is defined where the requirement on the mass factor m is 0,38. However, in this class the requirement is also that a higher than normal dosage of silica fume **shall** be used (8-10% by weight of cement).

5 CONCLUSIONS

Silica fume was introduced in the late seventies as a cheap, waste material mostly used as a strength improving material in low strength concretes. The durability for such concretes was questioned and requirements from a durability point of view were introduced from the early eighties. The application has gradually changed to the present situation where silica fume is used primarily to improve properties both in fresh and hardened state, especially durability.

When silica fume was introduced, the Directorate of Public Roads prohibited the use of it due to fear of long term durability. Today it is not allowed to build concrete structures for DPR without using silica fume due to better durability. However, during this period, standards and regulations have forced us to use silica fume as a quality improving material. This is also the situation internationally, partly because silica fume is priced several times as expensive as cement. Compared to this, silica fume is still relatively cheap in Norway, ranging between 100-200% of that of cement.

The consumption of silica fume is growing all over the world and due to shortage, it is reasonable that the price will be increasing in the future. This means that the application will be reduced to areas where the benefit is highest.

POROUS MATERIALS - STRUCTURE AND PROPERTIES



Anders Nielsen
 Tekn dr , docent
 Technical University of Denmark (DTU)
 Department of Engineering Structures and Materials
 Building 118
 DK-2800 Lyngby

ABSTRACT

This paper presents some viewpoints on the description of the pore structure and the modelling of the properties of the porous building materials. Two examples are given, where it has been possible to connect the pore structure to the properties. Ex. 1 deals with shrinkage of autoclaved aerated concrete, and Ex. 2 with the properties of lime mortar.

Key words: Pore characteristics, mechanical properties, aerated concrete, lime mortar.

1 INTRODUCTION

The structure and properties of the porous building materials have been a main research subject at the Department of Structural Engineering and Materials at DTU for many years. It is my intention in the following to give an impression of the methods we use, and to give some examples of, how the pore structure can be connected to the material properties.

The properties of a solid material are determined partly by the chemical binding of the solid phases in the material, partly by the way in which these solid phases are arranged.

Concerning the chemical binding it is commonly considered that metals are strong and tough, silicates are strong and brittle and organic materials are weak and tough.

The way in which the phases of the solid material are arranged also influences the properties, i.e. the properties are influenced by the shape and the internal arrangement of the phases. When one of the phases in a composite material is air, we have a porous material. The properties of a porous material are determined of the amount and the shape of the pores. This dependence is due to, among others, the following points.

Primarily the dependence is due to the fact that the lesser the volume of the solid, the lesser the influence of the solid, e.g. the strength diminishes with increasing pore

volume. - Further the shape of the solid material determines the flow of mechanical forces in the material and the stress concentrations and hereby the strength of the material. - Even further the water present in the pores interacts with the solid material, and so reduces the stiffness and strength of the material, gives rise to changes of the volume and contributes to the deterioration of the material.

2 PORE STRUCTURE

The structure of the porous material can be described by

- the total porosity,
- the pore size distribution, and
- the shape of the pores.

The way one choose to describe the pore structure depends on the connection, in which the description shall be used. The most convenient is to measure quantities, which can be used in a mathematical modelling of the mechanical properties. In the lack of mathematical models one can collect parameters for qualitative comparison between materials. This is the purpose with the pore size distribution described below. The method is used in our advanced course in porous materials on DTU.

The total porosity and the pore size distribution can be illustrated in a diagram showing the pore size as the abscissa and the cumulated pore volume per unit volume of the material as the ordinate (figure 1). The reason for the choice of this ordinate instead of the pore volume relative to the total pore volume (i.e. when the total pore volume is 100%) is that the total volume in itself tells something about the properties of the material, e.g., the strength decreases with increasing porosity. So the level of the top of the curve in the diagram will give a qualitative indication of the strength of the material.

In the diagram 100 nm is marked out especially. This is because the amount of pores in the region below 100 nm indicates how sensible the material is to hygroscopical influence on the dimensions, i.e. shrinkage and swelling.

No method exists which is able to measure the pore sizes from the coarsest to the finest pores. The curve must be pieced together by means of different methods, which more or less overlap each other, cf. figure 1. The methods fall in two groups. Pore sizes above the wave length of visible light can be measured directly by means of light microscope or electron scanning microscope (SEM). The smaller pores must be measured indirectly by "black box" methods, where the pore sizes are calculated from different pore filling techniques, such as water suction, micro calorimetry or mercury intrusion. The pieces of the pore size curve, which come from the different methods, must be put together to one curve. In this procedure it may be necessary to use an "engineering qualified guess" to get the pieces to fit together.

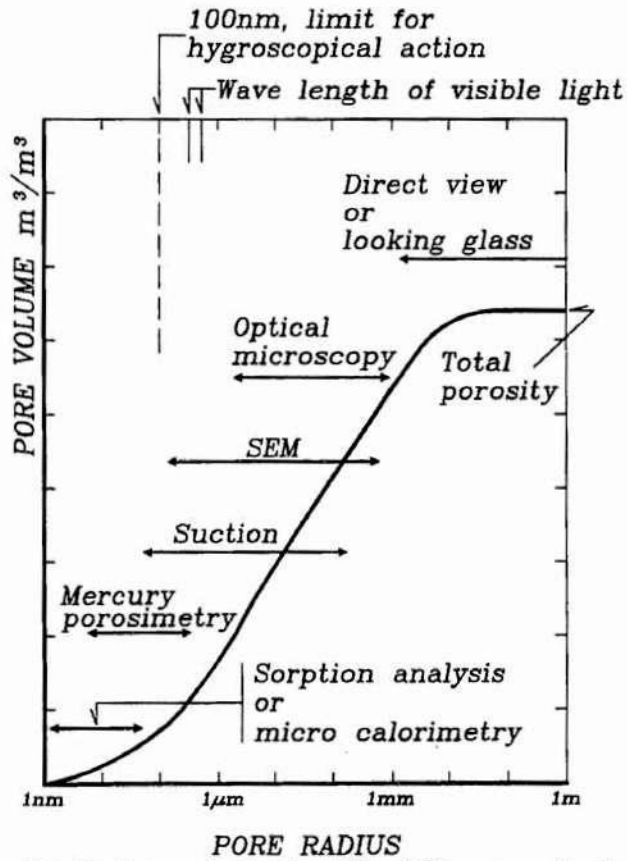

Figure 1. Pore size distribution, principally. The different methods to measure the pore sizes are printed along the curve.

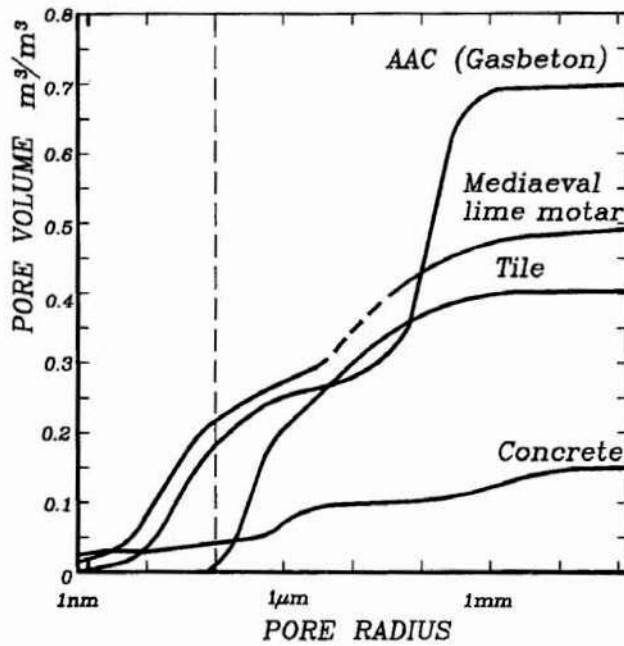

Figure 2. Examples of pore size distributions for different building materials. Collected at BKM, DTU.

In the building materials it has no meaning to measure pore sizes below 1 nm, as the diameter of the water molecule is 0,1 nm.

Figure 2 shows four examples of pore size distribution curves measured at our laboratory through the last years using the different techniques.

The shape of the pores is not studied to the same degree as the pore size distribution. This is due to the lack of models, where the information can be used. In the current modelling work described in the next section some proposals are made to the way in which the shape can be described. In the "black box" region of pores a hydraulic pore radius may be used. In the coarser pores in the visible region geometrical shape factors can be introduced. These shape factors shall be collected through image analysis.

3 MODELLING THE PROPERTIES

The connections between porosity and properties have been subject to world wide research for many years. A collection of research results from many countries made until 1972 was done by Göran Fagerlund /1/. This comprehensive report has been a great inspiration to the work on this field done at our laboratory at DTU. Here Lauge Fuglsang Nielsen has created a discipline of modelling the properties of composite materials in common and of the porous materials in particular. The theories apply to mechanical properties /2,3/ and to deteriorating processes, such as frost action /4/. Many of the expressions can be applied to other physical properties as well. A collected description of the theories are given in /6/.

Fuglsang Nielsen's work includes theory of elasticity, rheology, fracture mechanics and composite theory. Combining these tools in a smart way makes it possible to describe the properties of the materials from the properties and amount of the components in the mixed material. In the composite theory parameters are introduced, which describe the shape of the pores, so that the influence of the shape of the pores can be introduced in the calculations.

Among the results obtained with the theories shall be mentioned a method to predict the lifetime of wood and concrete subjected to various load histories. Recently the principles have been used to predict creep of concrete from 12 hours after casting /5/.

In the following two examples are given where modelling has been used with a certain success. Example 1 deals with the interaction between the solid matter and the water phase in pores in the "black box" region, below 100 nm. Example 2 treats the use of light microscopy to describe the shape of the visible pores.

4 **EXAMPLE 1** **SHRINKAGE OF AUTOCLAVED, AERATED CONCRETE**

In the Nordic countries drying shrinkage of autoclaved, aerated concrete (AAC) is measured as the change in strain of a test piece, which is dried from the moisture condition at delivery until equilibrium at 43% RH (Danish Standard DS 433.6). Following this procedure the Danish AAC for many years have shown the result 0% shrinkage (!)

To examine the background for this peculiar result an investigation was made by the Danish Building Research Institute, H+H-Industri A/S and the Building Materials Laboratory, DTU. Test pieces of AAC were dried out in steps from the moisture condition at delivery to equilibrium in 90, 80, 65, 50, 43 and 11 % RH. Afterwards they were wetted again in steps. The main result of the experiment is shown in figure 3. It is seen that at drying the material swells at the high RH-values before the shortening of the material takes over. At the re-wetting the material expands linearly as normally expected from a hygroscopic material /7,8/.

The modelling of this phenomenon is based on suggestions of the binding of water in the material. The water can be divided into four categories:

- water adsorbed to the internal surfaces
- water contained in micropores
- water contained in capillary pores
- free water filling up pores and voids.

The free water has no influence on the length changes and will be ignored in the following.

The amount of water bound in the material is presented by means of the sorption isotherm. The sorption isotherm was measured for the AAC. From this curve it was possible to calculate the amount of the different categories of water. The programme developed for this purpose is named SORP 1. (Figure 4)

When the amounts of the different categories of water is known it is possible to calculate the pore size distribution (Figure 5). The pore size is described as the hydraulic radius. The programme named SORP 2 makes this calculation..

From the pore size distribution the influence of the water on the solid skeleton can be calculated. This influence come from the change of the surface forces of the crystals in the material and from the hydraulic low pressure in the water (Figure 6). The programme developed for this purpose is named SORP 3.

From Figure 6 it is seen that apparently it is the disappearance of the capillary water in the region 95 to 75 % RH, which causes swelling, the same phenomenon which is seen

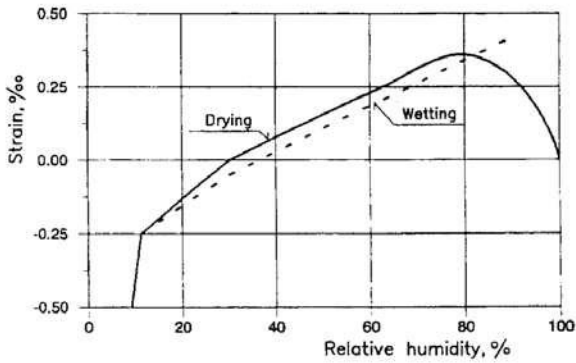

Figure 3. Movement in Danish AAC during drying in steps from delivery condition . The strain at re-wetting is also shown. (Results reported in /7/, reproduced from /9/.)

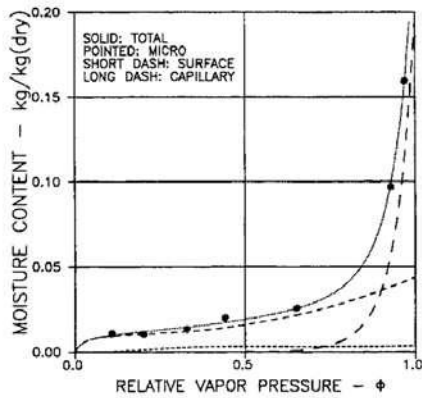

Figure 4. Sorption curve of Danish AAC. The different categories of water are shown /7/.

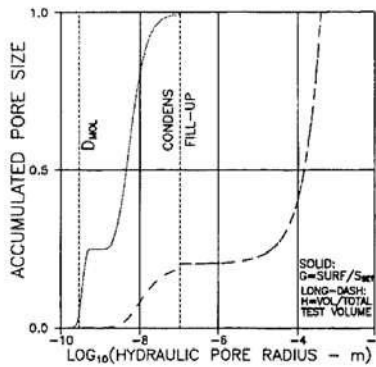

Figure 5. Pore size distribution in Danish AAC /7/.

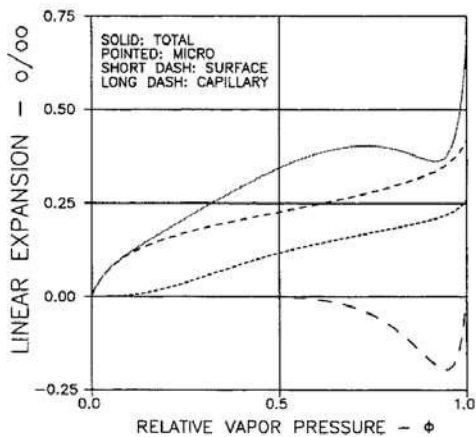

Figure 6. Calculated moisture determined strains of Danish AAC. The contributions from the different categories of water are shown /7/.

in the experiments (Figure 3). The magnitude of the calculated strains from 75 to 43 % RH is only the half of the strains observed in the experiments. This is due to inaccuracies in the model and to factors not taken into account. As a first attempt the result from the modelling is sufficient to describe the influence of the different kind of water phases.

So, the peculiar phenomenon of 0-shrinkage in the Danish AAC can be related to the pore size distribution. This again depends upon the manufacturing process. Other brands of AAC, which we have examined, also show this behaviour to some degree, but non of them as much as the Danish brand.

5 EXAMPLE 2 - LIME MORTARS

Lime mortars are known as weak materials with a rather low frost resistance. Meanwhile, lime mortars are widely used in restoration work on historical buildings, where it is very inconvenient to use cement based products. So, there is a need to improve the strength properties and the frost resistance of the lime materials. Thorborg von Konow has made a comprehensive work in order to make improvements on this field /10/.

A main idea in this work is to improve the pore structure of the materials by a suitable grain size composition of the binders and the aggregates, the coarse sand, as well as the fine powders. Addition of fillers of calcium carbonate or quarts has improved the pore structure of the hardened material markedly, and one have got a good workability at the same time.

The pore structure were studied in microscope on thin sections. Thorborg von Konow has a long experience looking in the microscope. She put the quality of the pore structure on a scale from 1 to 5 based on the *Overall Microscopical Impression*. Step 1 is bad quality with unregularly shaped, coarse and interconnecting pores. Step 5 is good quality with spherical, small and separated pores.

The properties measured in the investigation were, among others, the capillary suction, the frost resistance and the dynamic modulus of elasticity. These results of the measurements of these properties are shown on the figures 7, 8 and 9 as a function of the scale of the overall microscopical impression. It shall be pointed out that the total porosity of all the mortars is almost the same, around 30%.

Figure 7 shows, not surprisingly, that the capillary suction is reduced dramatically, as the pore structure is improved, and Figure 8 shows that the frost resistance, expressed as a frost index, also is improved. (This leads to the thought that the frost resistance problem is just a question of water transport into and inside the material.)

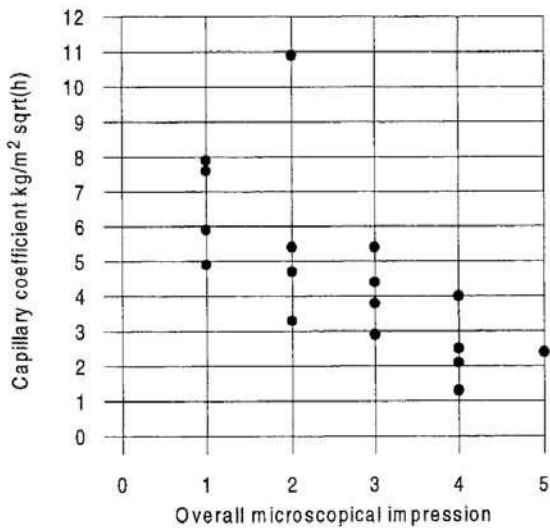

Figure 7. Lime mortars with porosity around 30%. Capillary suction coefficient versus the Overall Microscopical Impression. Data from /10/ visualised for the present paper.

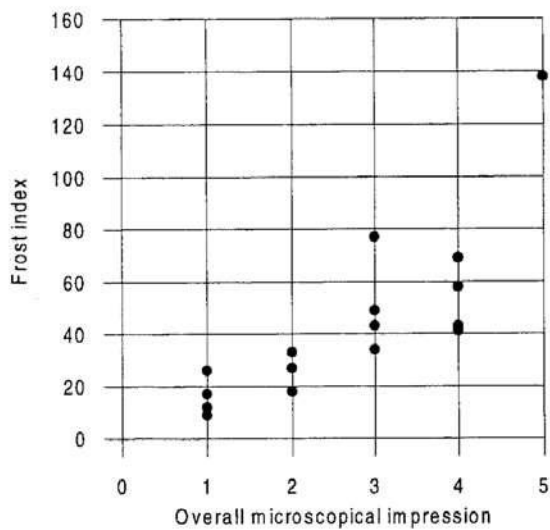

Figure 8. Lime mortars with porosity around 30%. Frost index versus the Overall Microscopical Impression. Data from /10/ visualised for the present paper.

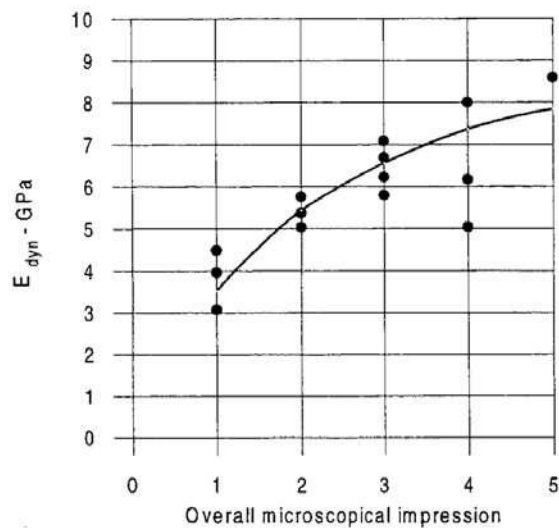

Figure 9. Lime mortars with porosity around 30%. Dynamic modulus of elasticity versus the Overall Microscopical Impression. Data from /10/ visualised for the present paper. The curve is developed from the composite theory /3/.

Figure 9 shows the dynamic modulus of elasticity relative to the overall microscopical impression. As the porosities of the tested materials are almost the same, the improvement of the stiffness can be related directly to the shape of the pores.

In /3/ a formula is developed, which expresses the modulus of elasticity of the material in question as a function of the stiffness of the solid material, E_{solid} , the porosity, c , and a pore shape factor, n . n varies between 0 and 1. 0 represents very flat pores, and 1 is related to spherical pores, i.e. the shape factor n expresses the same quality as the above mentioned parameter the Overall Microscopical Impression. Now, let us introduce the Overall Microscopical Impression (H) in the above mentioned formula, by replacing n with $H/5$, as H has a scale up to 5.

$$\frac{E}{E_{solid}} = \frac{(1-c)^2}{1 + \left(\frac{1}{n} - 1\right)c} = \frac{(1-c)^2}{1 + \left(\frac{5}{H} - 1\right)c}$$

With the values $E_{solid} = 16$ GPa and the porosity $c = 30\%$ the curve is drawn into Figure 9. The coincidence with the measured values is remarkable.

From Example 2 it is seen that it is possible to connect microscopical pictures to the properties of the porous material. A future research work is to transform the subjective "Overall Microscopical Impression" to an objective, quantitative method, which can be used in automatic image analysis.

6 FINAL REMARKS

The understanding of the connections between the pore structure and the properties of the building materials is vital for the rational use and further development of these materials. In the work with the description of the pore structure it is important to bear in mind that the parameters, by which we describe the structure, must have an anchoring in a mathematical model, whether this is empirical or theoretical.

REFERENCES

1. Göran Fagerlund: "Samband mellan porositet och materials mekaniska egenskaber" Rapport 26, Inst. f. Byggnadsteknik, Tekn. Högskolan i Lund, 1972.
2. Lauge Fuglsang Nielsen: "Elastic Properties of Two-Phase Materials". Materials Science and Engineering, Vol. 52, 1982, pp.39-62.
3. Lauge Fuglsang Nielsen: "Elasticity and Damping of Porous Materials and Impregnated Materials". Journ. Am. Ceram. Soc. Vol. 67, 1984, pp.93-98.
4. Lauge Fuglsang Nielsen: "Mechanics of composite material subjected to eigenstress - with special reference to frost resistance of porous brittle materials". Danish Build. Res. Inst., Bulletin 96, Hørsholm 1993.
5. Lauge Fuglsang Nielsen: "HETEK - Control of Early Age Cracking in Concrete - Phase 4B: Material Modelling, Composite Approach". Danish Road Directorate, Report 112, 1997.
6. Lauge Fuglsang Nielsen: "Composite Materials - Mechanical and Physical Behavior as Influenced by Phase Geometry". Monograph. Dep. Struct. Eng. and Materials, DTU, in press.
7. H.H.Knutsson, Anders Nielsen, L.F. Nielsen: "Svind i porebeton". Lab. for Bygningmaterialer, DTU, Technical Report 323-1995.
8. F.R. Gottfredsen, H.H. Knutsson, A. Nielsen: "Determination of length changes due to moisture variations in autoclaved aerated concrete". Materials and Structures, Vol.30, April 1997, pp 148-153.
9. Finn.R.Gottfredsen & Anders Nielsen (ed.): "Bygningmaterialer - Grundlæggende egenskaber". Polyteknisk Forlag, Lyngby 1997.
10. Thorborg von Konow: "Restaurering och reparation med puts- och murbruk". Thesis. Åbo Akademis förlag, Åbo, 1997.

A HISTORY LESSON ON THE DEVELOPMENT OF AND REQUEST FOR KNOWLEDGE - PREDICTION MODELS FOR CHLORIDE INGRESS INTO CONCRETE STRUCTURES AS AN EXAMPLE



Lars-Olof Nilsson
 Professor, PhD
 Dept. of Building Materials
 Chalmers University of Technology
 S-412 96 GÖTEBORG
 SWEDEN

ABSTRACT

The development of the knowledge on predicting chloride ingress into concrete structures stood almost still for some 20 years after the introduction in 1970. Two opposite types of models have then been developed: "empirical models" based on curve-fitting field exposure data resulting in regression parameters as material characteristics and "scientific models" based on the physical and chemical processes involved and independent test methods for decisive properties. The prediction models are still fairly uncertain and the prediction results indicate a need for far thicker concrete covers than usually used. The need for further knowledge and understanding is obvious, but the request for that is low. The long-term responsibility for maintaining and developing the knowledge must be taken.

Keywords: knowledge, understanding, chloride, models

1 INTRODUCTION

The service-life of concrete structures in marine and road environment is world-wide regarded as being limited by reinforcement corrosion initiated by chloride ingress through the concrete cover. Other deterioration mechanisms, such as frost or alkali-aggregate reactions, are simply avoided by the choice of constituents of the concrete, including proper air-entraining agents. Corrosion, however, is treated by *design*. The choice of concrete, cover thickness and production methods is derived from an estimation of the rate of chloride ingress and the required levels of chloride for corrosion to start. The rate of corrosion, once it is initiated, is sometimes included in the estimation of the potential service-life.

The true basis for such an estimation should be accurate and reliable predictions of chloride ingress. The development of today's knowledge on predicting chloride

penetration is an interesting history lesson on how knowledge is gained and to what extent knowledge and understanding are requested, or not requested, by researchers and engineers. Chloride ingress into *submerged* concrete is taken as an example since it should be the most simple case. Ingress of chloride in zones exposed to splash of sea water or de-icing salts can hardly be reliably predicted before we can make accurate predictions in the submerged zone.

2 THE FIRST 20 YEARS

Up till 1970, i. e. when the Öland Bridge was designed, no predictions of chloride ingress were made. Collepardi et al /1/ 1970 introduced Fick's 2nd law of diffusion for describing chloride ingress into concrete

$$\frac{\partial c}{\partial t} = D \frac{\partial^2 c}{\partial x^2} \quad (1)$$

with a "diffusion coefficient" D as a material property and a profile of total chloride concentration $c(x, t)$ as the measure of the penetration. For constant immersion into a chloride solution the ingress was predicted from the error-function solution to Fick's 2nd law

$$c = c_s \cdot \operatorname{erfc}\left(\frac{x}{2\sqrt{D \cdot t}}\right) \quad (2)$$

where $c_s = c(x=0, t)$ is the total chloride content at the concrete surface. The solution gives chloride profiles as shown in Figure 1.

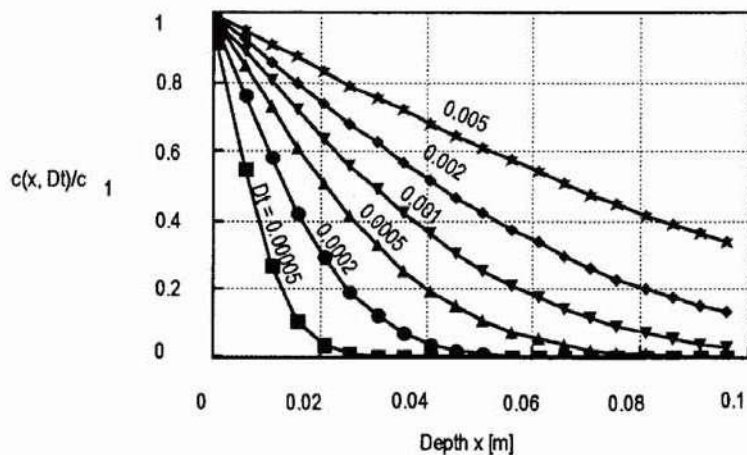

Fig. 1 The error-function solution to Fick's 2nd law of diffusion, giving chloride profiles at different exposure times.

Fick's 2nd law was not further analysed. It was believed that the diffusion coefficient D , and the chloride concentration c , were the same as in Fick's 1st law of diffusion, describing the flux J of chloride at a certain concentration gradient

$$J = -D \frac{\partial c}{\partial x} \quad (3)$$

A lot of laboratory experiments and field exposure tests were compared to these equations, giving two regression parameters D and c_s , from curve-fitting a measured chloride profile to the curves in Figure 1.

Alternatively, a diffusion coefficient D was measured in a diffusion cell experiment, utilising Equation 3 to derive a D . Then this D was used to make predictions by Equation 1 and Figure 1. In rare cases the c and c_s -values were regarded as the concentration of free chloride and the chloride binding capacity was introduced in Equation 1.

A number of concrete structures, such as i. e. the Great Belt Link in Denmark, were designed with Equations 1 and 2. These equations were regarded as the State-of-the-Art as long as up to 1991, i.e. in the report /2/ by the Swedish Concrete Association on durable concrete.

3 DIFFERENT D IN FICK'S 1ST AND 2ND LAWS

It was gradually realised in the early 1990s that the diffusion coefficients in Fick's 1st law and Fick's 2nd law are different, i.e. /3,4/, and that there is a relationship between the two diffusion coefficients:

$$D_{F2} = \frac{D_{F1}}{k} \quad (4)$$

or

$$\frac{dC}{dt} = \frac{d}{dx} D_{F1} \frac{dc}{dx} - \frac{dC_b}{dt} \quad (5)$$

$$\frac{dc}{dt} = \frac{d}{dx} \frac{D_{F1}}{k} \frac{dc}{dx}$$

where $k = p \frac{\partial c_{tot}}{\partial c}$, with p being the porosity, $C = c_{tot}$ = total chloride and c is free chloride.

This clarification did not change the significance of Fick's 2nd law for predictions but eliminated gross errors and misunderstandings, i.e. /5/, when using diffusion coefficients from steady-state diffusion cells tests.

4 NON-LINEAR BINDING

In those rare cases when chloride binding was introduced into Fick's 2nd law, i.e. by Tuutti 1982 /6/, the chloride binding capacity was always assumed constant, i.e. linear chloride binding. However, from a theoretical point of view, and from new, accurate measurements, it was obvious that chloride binding must be non-linear. The effect of non-linear chloride binding in Fick's 2nd law resulted in a concentration dependent k , that is, $k = f(c)$, and a concentration dependent diffusion coefficient!

With the non-linear binding taken into account, the chloride penetration profiles became rather strange, see Fig. 2. A few experimental results supported the effect, but most chloride profiles from field exposure had an erfc-shape.

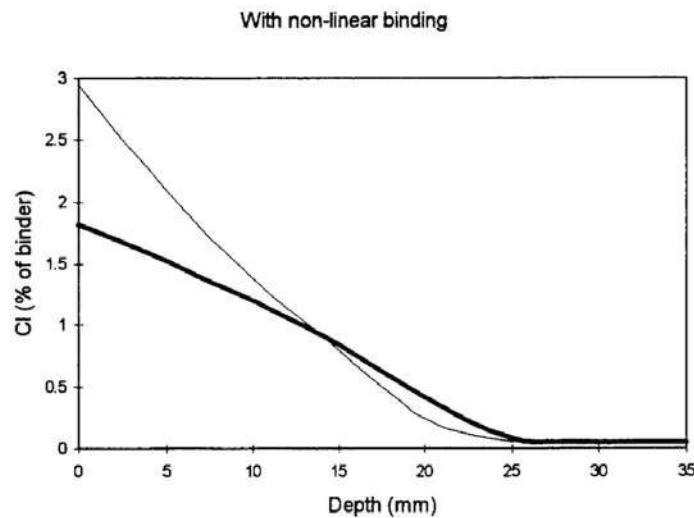

Fig. 2. A strange penetration profile with non-linear chloride binding (thick curve) compared to a profile with linear binding (thin curve), Nilsson et al (1996) /7/.

However, later on when leaching of hydroxide ions and the pH-effect on chloride binding were taken into account, simultaneously with non-linear binding, Tang (1996) /8/, the penetration profiles become "erfc-like", see Fig. 3.

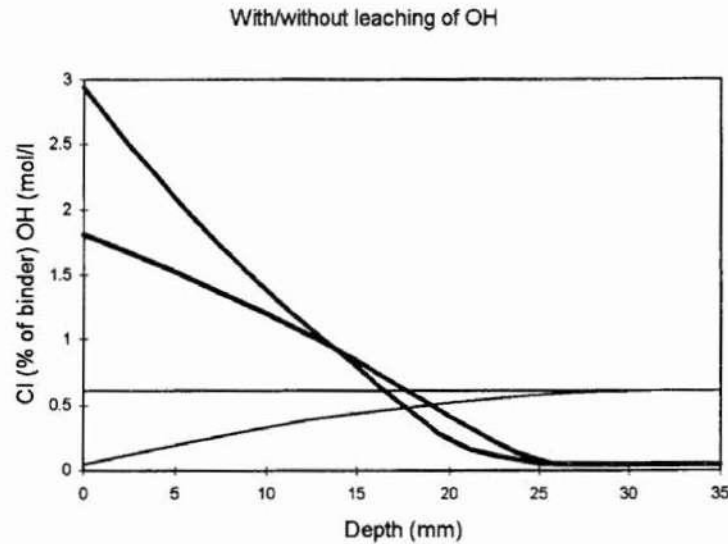

Fig. 3. Example of "erfc-like" profiles with hydroxide leaching compared to the profile in Fig.2 without leaching. OH-profiles shown with thin curves, Nilsson et al (1996) /7/.

5 SCIENTIFIC PREDICTION MODELS

Prediction models that are called "scientific" should be based on relevant and decisive physical and chemical processes, such as:

- the mass balance equation,
- a genuine flux equation,
- chloride binding relationships,
- the effect of material characteristics, and
- the effect of environmental conditions.

Such a method, a very sophisticated one called *ClinConc*, was presented in its last version 1996 by Tang /8/. He included most of the relevant knowledge into his model, i.e.

- non-linear chloride binding isotherms, including the significant effects of both pH and temperature,
- a chloride diffusion equation with the free chloride concentration as the driving potential,
- a chloride diffusion coefficient that is a function of age, temperature, distance to the cast surface etc.,
- a test method to measure the diffusion coefficient in an independent test,
- leaching of alkali hydroxides by a separate mass balance equation.

With Tang's model, predictions are made of total and free chloride distributions and the distribution of hydroxides. An example is given in Figure 4.

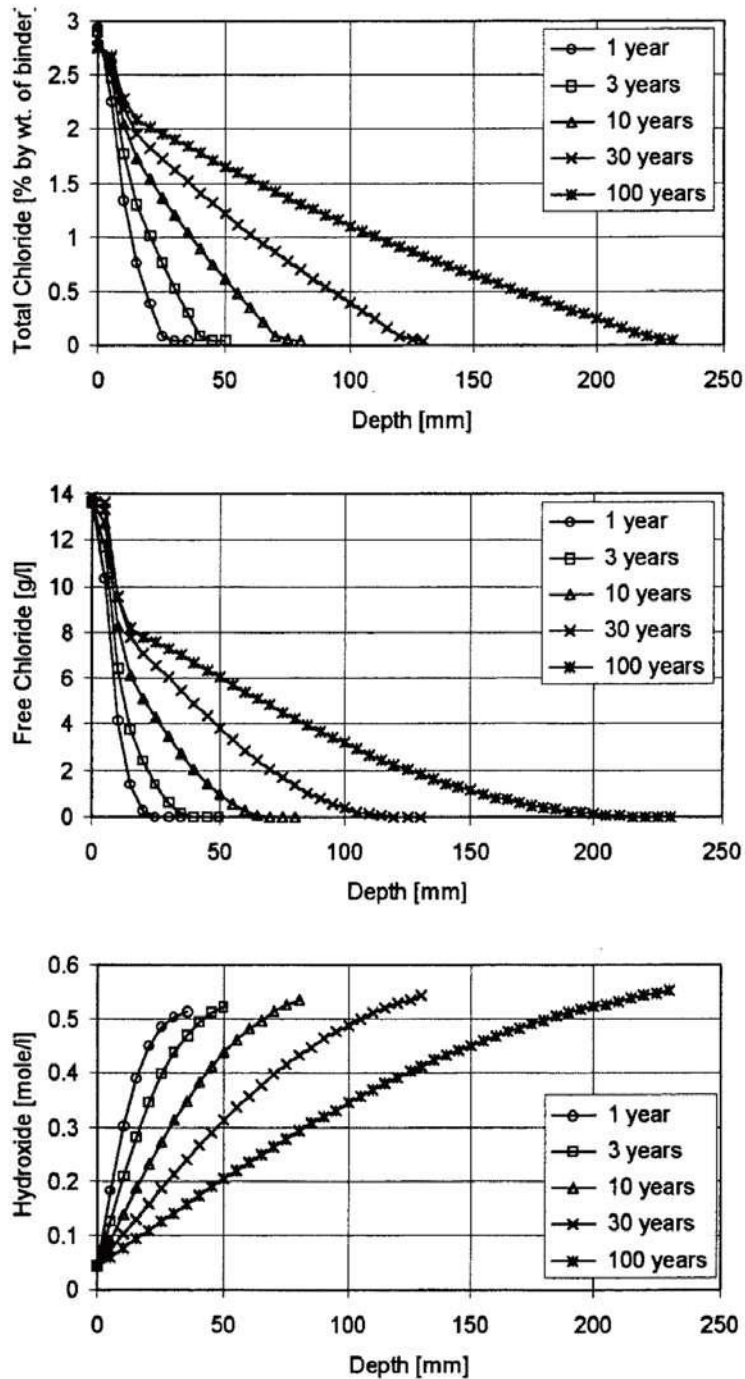

Fig. 4 Predicted distributions, by ClinConc, of total (top) and free (centre) chloride concentrations and distribution of hydroxide (bottom) for the concrete used in the Öresund Bridge.

The scientific prediction model *ClinConc* gives accurate predictions in most of the cases where predictions have been compared to measured chloride profiles, with a few exceptions:

- Predicted penetration is too high when compared with that measured after the exposure according to the NT BUILD 443 test, see Fig. 5 /9/. In such a test the chloride concentration is very much higher than at normal exposure.
- The effect of non-saturated pores is not yet considered in a completely correct way. A number of measurements show that good concrete is far from saturated in the submerged zone, also after very long exposure times.
- The effect of temperature on chloride binding is still unclear. Experiments still do not confirm what is theoretically expected, which gives a large uncertainty.

The next steps in improving scientific models should be: 1) a concentration dependent diffusivity $D_{FI}(c)$, as shown in Fig. 6, and 2) a saturation dependent diffusivity $D(S)$, where S is the degree of saturation.

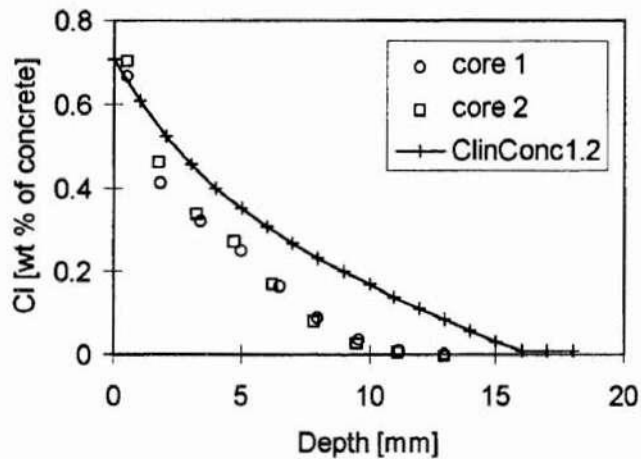

Fig. 5. A comparison of predicted (by ClinConc) and measured chloride profiles for an accelerated immersion test (NT Build 443) of an SRPC concrete with $w/c = 0.3$. Age at exposure 28 days. Duration of test 35 days, Nilsson et al (1997) /9/.

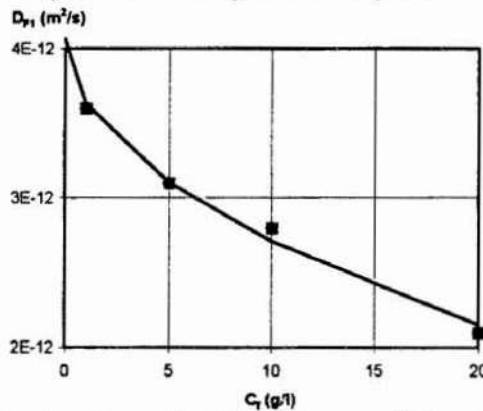

Fig. 6. Concentration dependent diffusion coefficient in Fick's 1st law, Nilsson et al (1996) /7/, based on data from Bigas (1994) /10/.

6 EMPIRICAL PREDICTION MODELS

Simultaneously with the development of the scientific model described in section 6, empirical models have run through a significant improvement. They are all based on curve-fitting experimental data

6.1 Time dependent diffusion coefficients

Around 1990 more and more observations indicated that the “achieved diffusion coefficient” D_a in Fick’s 2nd law could not be treated as a constant for a particular concrete. There seemed to be a time effect or an age effect /11, 12/.

This time effect was introduced in prediction models by using Fick’s 2nd law with a time dependent $D_a(t)$. At first the time effect on the diffusion coefficient was believed to be an age effect as shown experimentally, but later on the age effect could not be seen experimentally at ages over six months. Predicted “achieved diffusion coefficients” $D_a(t)$ by the scientific model did not decrease with time /9/. Alternative explanations for the time effect are still missing!

From numerous long-term exposure tests time dependent “achieved diffusion coefficients” are indicated. However, most of these measurements are done in the splash zone and not in submerged concrete where *ClinConc* is applicable. Much more long-term tests in the submerged zone are required to confirm or reject the time effect.

6.2 Time dependent surface chloride concentrations

The last few years Poulsen /13/ has further improved his empirical model to include also a time effect on the surface chloride content, cf. Figure 7.

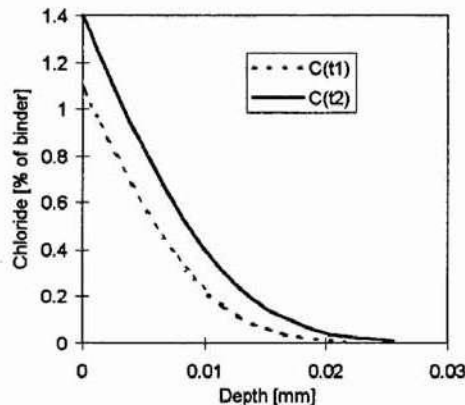

Fig. 7 An example of typical chloride profiles in the Mejlbro-Poulsen Model.
The surface chloride content increases with time.

The erfc-solutions are no longer applicable, since the boundary conditions are different. New solutions to Fick’s 2nd law were required to include that the surface

chloride content increases with time. Mejlbro developed the mathematics needed to solve Poulsen's equation /13/.

The Mejlbro-Poulsen Model contains a large number of parameters that have to be determined by curve-fitting measured chloride profiles at different exposure times. The quality of measured profiles must be very good to obtain a reasonable accuracy. Since most available profiles from structures are only from a single exposure time, there is a tremendous lack of data to calibrate the Mejlbro-Poulsen Model at longer exposure times. The best available profiles, from the Swedish BMB-project, were used by Fredriksen /14/ to make a multiple regression analysis of chloride profiles from three exposure times for a large number of concretes, submerged and exposed to splashing sea water and air borne chloride. From that analysis material characteristics and environmental conditions could be quantified.

However, the data used were limited to up to two years of exposure, the youngest profiles from only half a year. It was shown that the data had fairly large scatter that decreased the reliability of the quantification. Consequently, predictions made with the model still are rather uncertain. Data from longer exposure times are required. Five year data will be available later this year, which is expected to significantly improve the model.

9 DISCUSSION & CONCLUSION

Prediction of chloride ingress into concrete structures is a good, but may be somewhat extreme, example on how knowledge develops and on the lack of request for real understanding and scientific quantification. Large parts of industry, and research community, more or less accept the statements from "Experts" without any deep, individual knowledge and understanding. The ability and confidence to question "old truths" are not widely spread. Consequently, they may live far too long.

There is a need for some institutions in society to take a long-term responsibility for the development of knowledge within a specific topic. A topic may become "modern" and popular and attract a lot of research resources during a limited time. That kind of research too often starts from "scratch" and does not significantly improve knowledge and understanding. Instead a number of additional questions may be added by confusing results. The best outcome may be only additional data.

Institutions at universities should take that responsibility, and they frequently do. However, a single institution does not have the resources to take the responsibility for more than a few topics. On top of that, it is difficult to find funding for topics that is more or less fundamental research but has a clear application. It may "fall between chairs". Research councils may find it "too applied" and most parts of industry may find it "too far out in the blue sky".

Institutions in the industry, such as certain qualified consultants, could take part of that responsibility that lies between fundamental and applied research. The "joint venture" between a university institution and a very competent consultant in the Danish HETEK-1 project /9/ is a good example of that.

REFERENCES

- /1/ Collepardi, M.; Marcialis, A.; Turriziani, R. (1970) *The kinetics of chloride ions penetration in concrete* (in Italian). *Il Cemento*, Vol. 67, pp. 157-164
- /2/ *Durable Concrete* (in Swedish), Concrete Report No. 1, Swedish Concrete Association.
- /3/ Massat, M. (1991) *Caracterisation de la microfissuration, de la permeabilite et la diffusion d'un beton: Application au stockage des dechets radioactifs*. These du Doctorat INSA, Genie civil, Laboratoire Materiaux & Duralibilite des Constructions, Toulouse.
- /4/ Massat, M, Nilsson, L-O & Ollivier, J-P (1992) *A clarification of the fundamental relationships concerning ion diffusion in porous materials*. Third International Colloquium on Materials Science and Restoration, December 1992, Technische Akademi Esslingen, Germany.
- /5/ Tang, L & Nilsson, L-O (1992) *Rapid determination of chloride diffusivity of concrete by applying an electric field*. *ACI Materials Journal*, Vol. 49, No. 1, pp. 49-53.
- /6/ Tuutti, K (1982) *Corrosion of Steel in Concrete*. Swedish Cement and Concrete Research Institute, Stockholm. Report No. CBI Research FO 4:82.
- /7/ Nilsson, L.O., Poulsen, E., Sandberg, P., Sørensen, H.E. and Klinghoffer, O. (1996), *HETEK, Chloride penetration into concrete, State-of-the-Art, Transport processes, corrosion initiation, test methods and prediction models*, The Danish Road Directorate, Report No. 53.
- /8/ Tang, L. (1996), *Chloride transport in concrete - Measurement and prediction*, Dept. of Building Materials, Chalmers University of Technology. Publication P-96:6.
- /9/ Nilsson, L.O., Sandberg, P., Poulsen, E., Tang, L., Andersen, A. and Frederiksen, J.M. (1997), *HETEK, A system for estimation of chloride ingress into concrete, Theoretical background*, The Danish Road Directorate, Report No. 83.
- /10/ Bigas, J.-P. (1994), *La diffusion des ions chlore dans les mortiers* (In French), These de Doctorat INSA-Genie Civil, LMDC, INSA de Toulouse.
- /11/ Maage, M.; Helland, S.; Carlsen, J.E. (1994) *Chloride penetration in high performance concrete exposed to marine environment*. Proc of RILEM international Workshop on Durability of High Performance Concrete, Wien, February 14-15 1994, ed. by H. Sommer, pp. 194-207.
- /12/ Poulsen, E (1996) *Prediction models*. Chapter 7 in /7/.
- /13/ Poulsen, E (1997) *Details of the Mejlbros-Poulsen Model*. Chapter 3 in /9/.
- /14/ Frederiksen, J M (1997) *Expectation values for typical chloride environments*. Chapter 13 in /9/.

REFLECTIONS ON SCALING RESISTANCE TESTING OF CONCRETE



Per-Erik Petersson
 Dr Sci
 Swedish National Testing and Research Institute, SP
 Box 857
 501 15 Borås
 SWEDEN

ABSTRACT

Knowledge of scaling resistance of concrete is mainly based on experience and, consequently, the theoretical base, on which scaling resistance testing stands, is weak. Existing test methods were developed for traditional concrete qualities, but they cannot be expected to always be useful for new concrete types, such as high-performance concrete, etc. In this paper, reflections are made on parameters influencing the scaling resistance test results. These parameters are the freeze/thaw cycle, the pre-conditioning of specimens and the salt solution used for testing. The reflections are followed by recommendations on how to perform scaling resistance testing and how to evaluate the results. Where knowledge is lacking, the need for research is identified. Finally, recommendations for standardisation of scaling resistance test methods are given.

Key words: Concrete, scaling resistance, testing, standardisation

1 EXISTING KNOWLEDGE OF SCALING RESISTANCE TESTING IS BASED MAINLY ON EXPERIENCE

Knowledge of the testing of scaling resistance of concrete is mainly based on experience. In Sweden, Portland cement has been used as a binder in concrete for over a century, and we have had access to air-entraining agents for more than 40 years. This has made it possible to gain experience on how "common" concrete functions under normal conditions in the Swedish climate, and how to test it. Test methods have been developed which make it possible to assess the quality of concrete. It must be kept in mind, however, that our knowledge of test methods is primarily based on experience and not on basic knowledge of deterioration mechanisms. The usefulness of existing test methods is therefore mainly limited to commonly used Portland cement concrete qualities. If we use other types of cement than Portland cement, other admixtures than pure air-entraining agents, very low water/binder ratios, etc., we often do not have suf-

ficient experience and knowledge either of how a frost resistant concrete should be composed, or of how it should be tested. Better knowledge and more experience must be acquired.

Results from scaling resistance tests /1/ are presented in figure 1. Two concrete qualities, A and B, were subjected to repeated freezing and thawing in a sodium chloride solution. The frost resistance was characterised as the loss of mass as function of the number of freeze/thaw cycles.

In quality A the binder was a pure Portland cement, in quality B 19% of the cement was replaced with silica fume. With the exception of this difference, the qualities were identical. The water/binder ratio was low, 0.35 and no air entraining agent was used.

As can be seen in the figure, the two concrete qualities reacted completely differently to the freezing and thawing. The Portland cement concrete showed, exactly as expected, continuously increasing loss of mass when the number of freeze/thaw cycles increased. For the silica fume concrete, on the other hand, almost no mass loss at all took place during the first 100 cycles. Then, after more than 100 cycles, the concrete suddenly became completely disintegrated within a few freeze/thaw cycles. For this very dense concrete, the water uptake is very slow. The critical degree of saturation /2, 3/ is therefore not reached until after a large number of cycles corresponding to a long period of capillary suction. When the critical degree of saturation is reached, however, degradation due to frost attack develops very quickly.

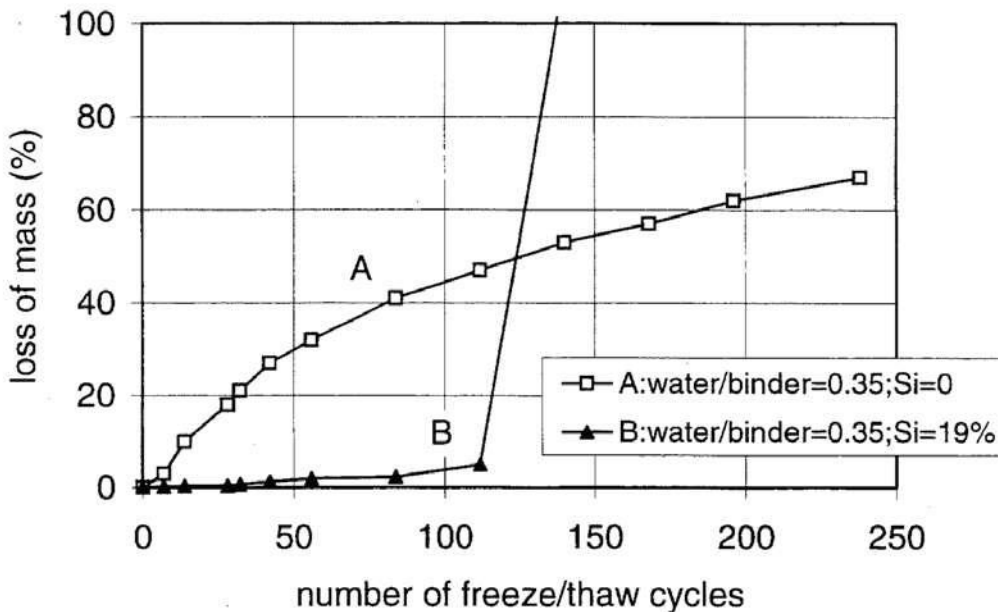

FIGURE 1 Scaling resistance test results for two concrete qualities, with and without silica fume /1/.

It is not possible, using the results in the figure, to judge which of the two concrete qualities have the best frost resistance. The results, however, clearly show that it is necessary to be careful when evaluating the scaling resistance of new types of concrete using test methods developed for traditional concrete qualities.

Most scaling resistance test methods have been developed to be used for normal strength concrete qualities, produced with pure Portland cement. The number of freeze/thaw cycles is normally limited to about 56, sometimes only to 28. As can be seen in the figure, the "long term" scaling resistance for the Portland cement concrete, quality A, can already be predicted after about 25 cycles. The conclusions would, on the other hand, be completely misleading, if the same evaluation was made for the silica fume concrete after 25 or even 50 cycles. The test method used is obviously functional primarily for Portland cement concrete qualities, for which it was developed, and not for new types of concrete for which no experience has been acquired.

This paper contains some reflections about a few parameters influencing scaling resistance testing. These reflections are sometimes followed by recommendations on how to perform scaling resistance testing. Where knowledge is lacking, the need for research is identified.

2 THE FREEZE/THAW CYCLE

In two simply but very clever experiments performed in the early 1950s /4/, Powers and Helmuth illustrated the two mechanisms normally assumed to cause degradation of concrete when exposed to freeze/thaw, see figure 2.

According to *the hydraulic pressure mechanism* /5/, the internal pressure causing damage increases with increasing ice formation rate, but not with the total amount of ice formed. The internal pressure increases with increased cooling rate and, as a consequence, for zero cooling rate, the internal pressure is zero. This is illustrated in figure 2a. The frost attack caused by the hydraulic pressure therefore can be stated to be cooling rate dependent.

The other main mechanism is *the microscopic ice crystal growth mechanism* /3/. According to this theory, ice in the pores attracts unfrozen water, the driving force being the energy difference between ice and the water. This makes the ice crystals grow, causing pressure on the pore walls, which may induce frost damages. The water transport continues, and thus the evolution of damage, even when the temperature is held constant at a temperature below zero, which is illustrated in figure 2b. This mechanism is not sensitive to the cooling rate but it is, on the other hand, dependent on the time the concrete is kept in an environment with a temperature below zero degrees.

The frost attack is probably caused in most cases by a combination of the two mechanisms. The hydraulic pressure mechanism is, however, normally assumed to be domi-

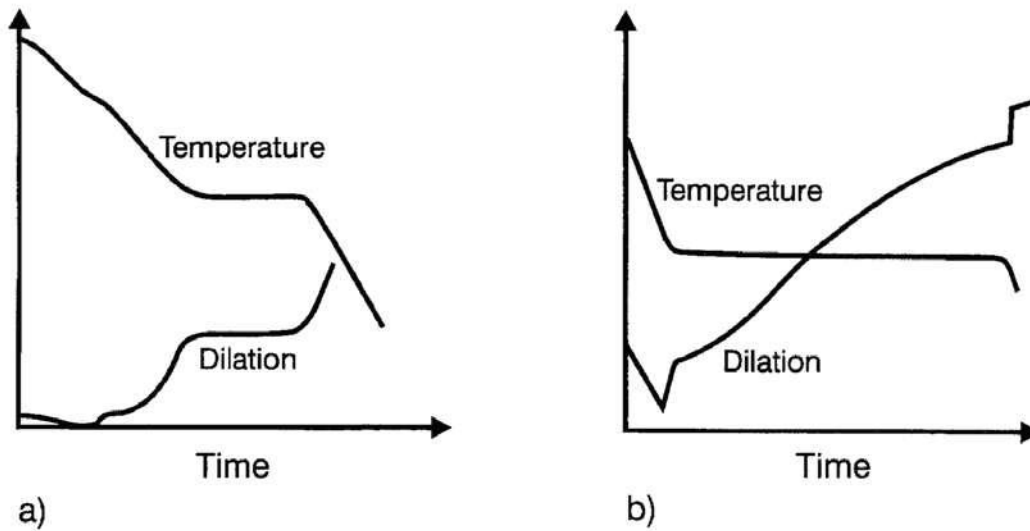

FIGURE 2 a) Dilation-temperature curves illustrating the *hydraulic pressure mechanism* for a concrete with $W/C=0.6$
 b) Dilation-temperature curves illustrating the *microscopic ice crystal growth mechanism* for a concrete with $W/C=0.45$ [4].

nant for concrete with high water/cement ratios (above 0.5) while the microscopic ice crystal growth mechanism is dominant for lower water/cement ratios.

This means that "modern" high-performance concrete qualities such as bridge concrete, and also high-strength concrete with very low water/cement ratios, ought to be insensitive to the cooling rate, when subjected to freeze/thaw testing. These concrete qualities, on the other hand, ought to be sensitive to the time they are kept in an environment with a temperature below zero degrees. For concrete of poorer quality, the situation may be the opposite.

Testing concrete for frost resistance is time consuming. In many test methods, the concrete is subjected to about 25 to 50 freeze/thaw cycles and the duration of each cycle is in most cases 24 hours. This means that it takes, including the pre-curing of the specimens, up to three months from the production of the concrete until the test results are available. This is often considered too long.

Shorter freeze/thaw cycles are sometimes used in order to speed up the procedure, for example 2 or more cycles per day. This means that the cooling rate is increased and also that the time below zero degrees is shorter for each cycle. The time below zero degrees for the entire testing period is also shorter, on the assumption that the total number of cycles is kept constant. This means, according to the discussion above, that increasing the number of cycles per day strengthens the frost attack on concrete qualities with higher water/cement ratios but weakens it for qualities with lower water/cement ratios.

Preliminary test results from an ongoing European round robin test /6/ are in agreement with the assumptions above. In the round robin test, the scaling resistance of two concrete qualities, with water/cement ratios of 0.45 and 0.55 respectively, was determined. The tests were performed using three test methods, two of which are similar in principal but have different freeze/thaw cycles. The two methods are the Slab method /7/ and the CDF method /8/.

The freeze/thaw cycles for the two methods are presented in figure 3. The cooling rate is much higher and the time below zero lower for the CDF-method than for the Slab method.

The preliminary results from the round robin test indicate that the CDF-method gives higher scaling than the Slab method, for the concrete with the highest water/cement ratio, 0.55. For the concrete with the water/cement ratio of 0.45, however, the situation is different and the Slab method gives significantly higher scaling than the CDF-method. These findings are in agreement with the hypothesis regarding the effects of the freeze/thaw cycle on the test results stated above.

The shape and duration of the freeze/thaw cycle obviously has a significant effect on the test results. When changing the cycle the intensity of the frost attack also changes. The change of the intensity of the frost attack is, however, dependent on the quality of the concrete tested. This makes it unsuitable to accelerate the test by increasing the cooling rate or shortening the duration of the cycles. Based on current knowledge, a freeze/thaw cycle, therefore, should resemble the cycles occurring in the field as closely as possible. The cooling rate, therefore, should be about 1,5-3 °C/h, which is

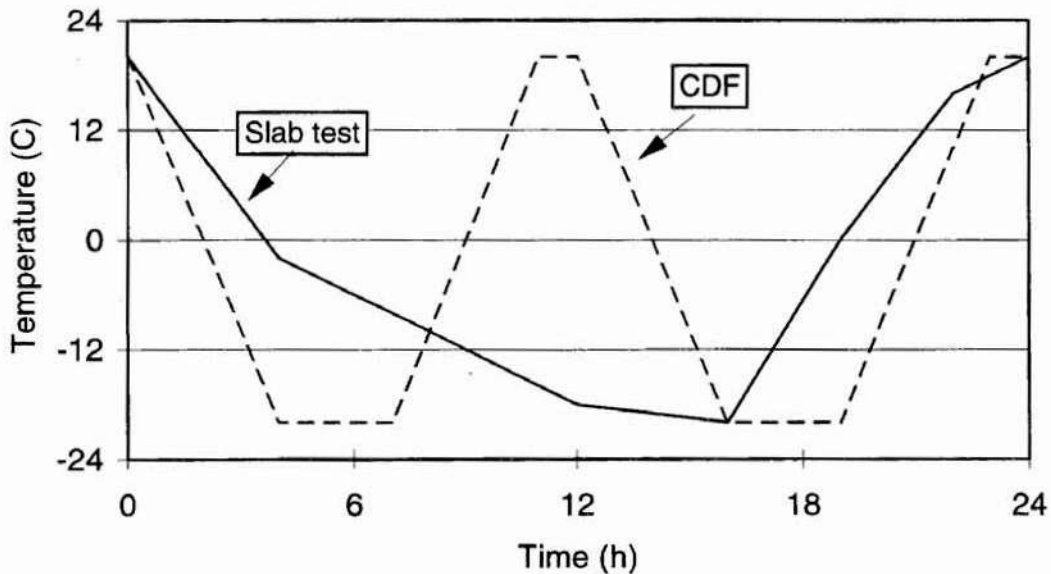

FIGURE 3 The freeze/thaw cycles, used in the European round robin test, for the CDF and the Slab methods respectively.

the maximum cooling rate found in most parts of northern and central Europe. In some regions, for example in the Alps where sometimes high day-time temperatures are combined with low night-time temperatures, higher cooling rates may be justified.

A twenty-four hour duration of the freeze/thaw cycle seems reasonable, since this resembles the daily temperature cycles in nature. Using 56 cycles, the total time below zero degrees will be about one month for the entire test. This is probably relatively representative for winter seasons in many parts of northern and central Europe. In some cases, for example where very dense concrete is concerned, it may be necessary to use more cycles. This need is illustrated in figure 1, where no scaling took place for the very dense silica fume concrete until after 100 cycles.

The minimum temperature also influences the scaling resistance, see for example /9, 10, 11/. It seems reasonable to set a minimum temperature close to the lowest temperature occurring in nature. Thus -20°C may be used, as a compromise, for most of Europe. In some regions, such as the British Isles and Mediterranean coast, higher values for the minimum temperature may be better.

One advantage of using a minimum temperature of -20°C is that the temperature sensitivity seems less pronounced around this temperature than for higher values /9/. This is positive, since lower temperature sensitivity can be assumed to result in a lower scatter of the test results.

On the basis of the discussions above, the following recommendations can be made concerning the temperature cycle, when testing the freeze/thaw resistance of concrete. The recommendations are in good agreement with Fagerlund's findings in /12/:

- *More research is needed to increase our knowledge about the relation between the freeze/thaw cycle and the scaling resistance, not least where very dense, high-strength concrete qualities are concerned*
- *With current knowledge, it is recommended that the freeze/thaw curve should resemble the natural temperature variations in the field. This means a cycle duration of 24 hours and a minimum temperature of -20°C , which, as a compromise, can be assumed to be representative for most parts of Europe. In some regions, however, other temperature cycles may be better.*
- *The number of freeze/thaw cycles should not be less than 50. For dense, high-performance concrete qualities, a higher number of cycles is probably better.*

3 PRE-CONDITIONING

Results from freeze/thaw tests /13/ on Portland cement concrete specimens subjected to different pre-conditioning climates are presented in figure 4. The specimens were 28 days old at testing and sawn surfaces were used. The axes in the figure represent the scaling after 56 cycles, when tested according to the Slab method /7/, and the pre-conditioning climate in which the specimens were stored during the last week before testing. The climate was characterised using the evaporation rate, representing the evaporation rate from a free water surface in a water-filled bowl, placed in the same climate chamber used for pre-conditioning. The higher the evaporation rate, the "drier" the climate. Various relative humidity values and different wind velocities resulted in the different climates. The temperature was kept constant at 20°C during the pre-conditioning.

The results in figure 4 show that the pre-conditioning climate strongly influences the test results. For the two concrete qualities with the best scaling resistance, A and B, the scaling is higher for low and high values of the evaporation rate, but lower in between. For the quality with the poorest scaling resistance, C, the scaling increases continuously with increasing evaporation rate. Similar results are also reported in /14/.

When testing the scaling resistance, the pre-conditioning is often performed in a climate with very low wind velocity and with a relative humidity of 50-65%. This corresponds to an evaporation rate of about 20-80 g/m²h, within which range the results

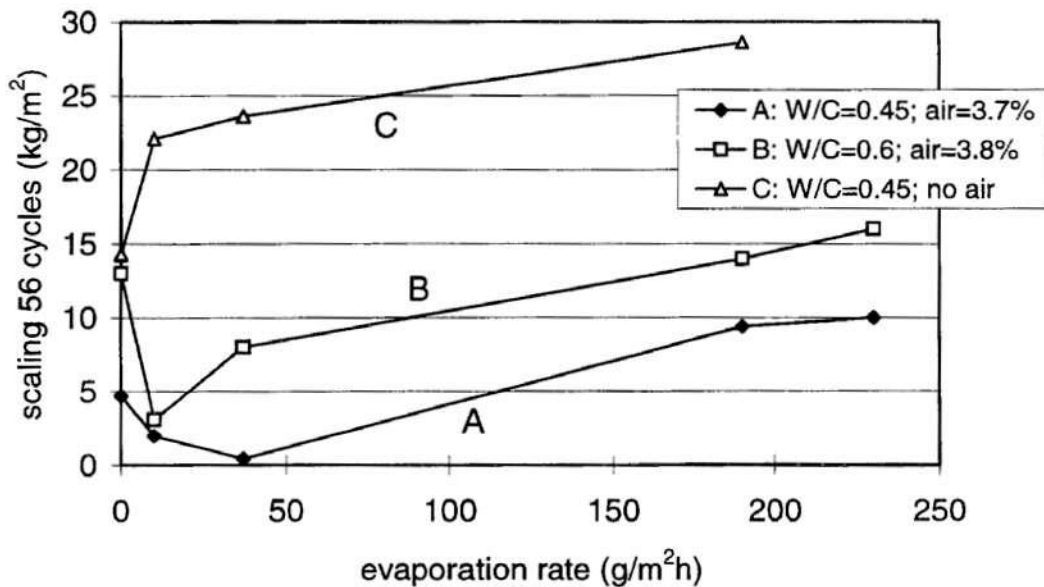

FIGURE 4 Scaling as functions of the pre-conditioning climate, measured as evaporation rate from a free water surface in the climate room. The temperature during pre-conditioning was 20°C. Portland cement was used as the only binder for all the concrete qualities.

seem to be extremely sensitive to the pre-conditioning climate. The pre-conditioning, therefore, is probably the most critical moment when testing scaling resistance. The climate must be specified very exactly, otherwise it will not be possible to obtain acceptably low values for repeatability and reproducibility.

Results from another investigation /15/, where concrete specimens were subjected to two different curing climates, are shown in figure 5. The two climates were identical except that the relative humidity was 50 and 65%, respectively. The values of the evaporation rate from a free water surface in the climate rooms were $33 \text{ g/m}^2\text{h}$ for 65% RH and $45 \text{ g/m}^2\text{h}$ for 50% RH. Both these evaporation values fulfil the requirements for the scaling resistance test methods most frequently used in Europe /7, 8/.

Ordinary Portland cement was used as the only binder. The water/cement ratio was 0.50 and the air content 2.9%. The tests were performed on 28 day old concrete on sawn test surfaces. The pre-conditioning period was 7 days.

Figure 5 shows that the pre-conditioning climate strongly influences the test results, even for relatively small differences, such as between 50 and 65% relative humidity. The two lower curves show that the scaling differs with a factor of ten or more between the two climates.

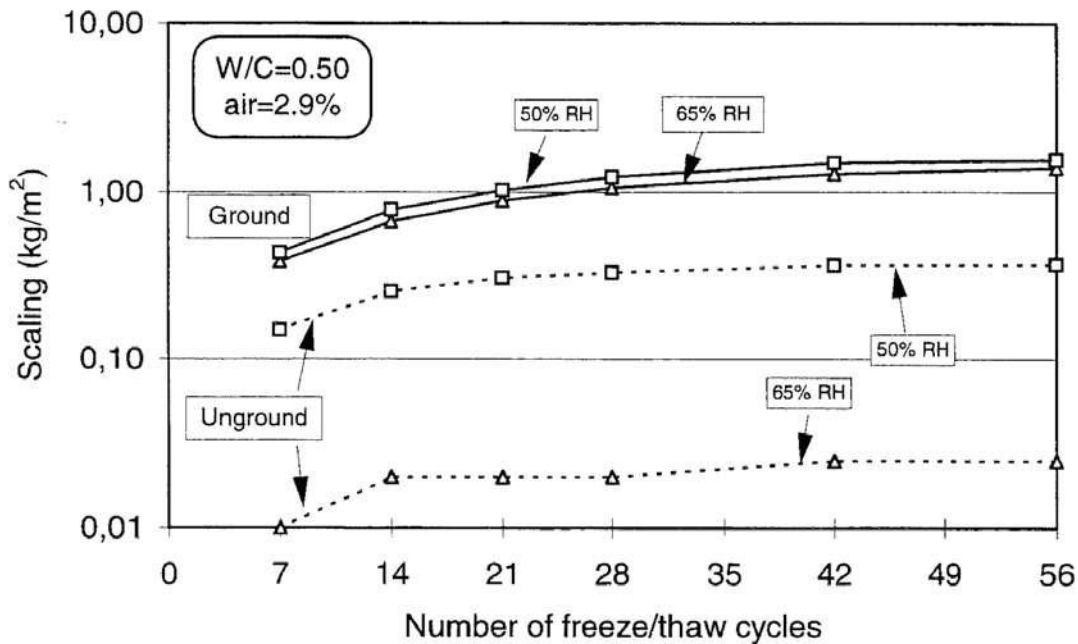

FIGURE 5 Scaling vs. the number of freeze/thaw cycles for specimens preconditioned for seven days in two different climates. The two upper curves represent specimens where a thin layer was ground from the test surface directly before testing. The two lower lines represent unground specimens.

The two upper curves in figure 5 also represent results for specimens conditioned in the two climates. However, directly before the testing an about 0.5 mm thick layer was ground from the test surface. The removal of a thin layer resulted in increased scaling, but the influence of the pre-conditioning completely disappeared. This proves that a very thin protective layer is created on the test surface during the pre-conditioning period, and the quality and/or thickness of this layer seems to be very much influenced by the pre-conditioning regime.

In figure 6, results from an ongoing project are presented /16/. In the project, the influence of carbonation was investigated. Portland cement concrete, with a water/cement ratio of 0.45 and an air content of 4.5%, was tested at an age of 28 days. The specimens were preconditioned for seven days at +20°C and 65% RH. During the first day of pre-conditioning, some of the specimens were kept in an environment completely free from carbon dioxide, while others were stored in an environment with a natural carbon dioxide content of about 0.03%. During the last six days before testing all the specimens were kept in an environment free from carbon dioxide.

The results show that even a very short exposure to carbon dioxide creates a protective layer on the test surface. If no carbonated layer is created, as is the case for the specimens representing the upper curve in the figure, the scaling is large even for the high quality concrete used in the project. It seems, therefore, that the good scaling resistance properties of Portland cement concrete are strongly dependent on a protective carbonated layer, which may be very thin.

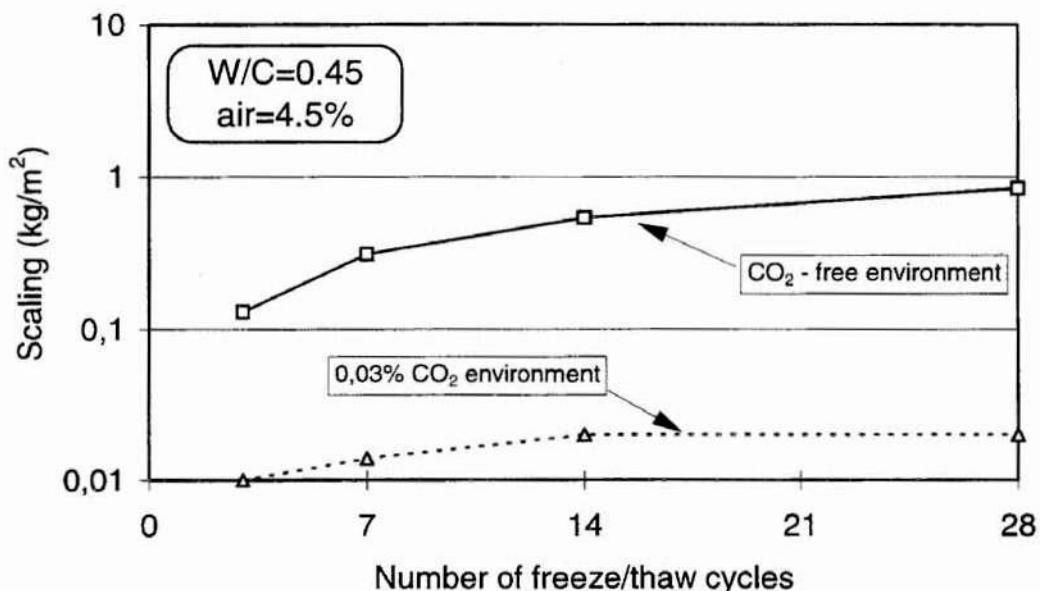

FIGURE 6 Scaling resistance as a function of the number of freeze/thaw cycles for different pre-conditioning climates. The lower curve represents specimens kept one day at 0.03% CO₂ before testing. The upper curve represents specimens kept in a CO₂-free environment all the time until testing /16/.

The positive effect of carbonation fully explains the effects shown in figures 4 and 5. For qualities A and B in figure 4, the scaling is high when the evaporation rate is close to zero, owing to the fact that the specimens remain wet and no carbonation can take place. When the evaporation increases, the concrete carbonates which leads to less scaling. When the evaporation increases even more, on the other hand, the specimens dry very quickly during the pre-conditioning period, which slows down the carbonation process. The scaling therefore increases. For quality C, with poor scaling resistance, the quality of the carbonated layer seems to be poor and, consequently, it is scaled off already after a few freeze/thaw cycles, and influences the scaling very little. For this poor concrete quality, the scaling increases continuously with increased drying, which can be assumed to always be the case for *uncarbonated* Portland cement concrete.

According to these results, the scaling ought to be dependent on the length of the pre-conditioning period, and this is confirmed by the results in figure 7. In the figure results are compared for periods of pre-conditioning of 7 or 21 days. Specimens with sawn surfaces were used and the results are relevant for concrete produced with Portland cement. As can be seen, a longer pre-conditioning period leads to significantly lower scaling in the interval 0.1-1.0 kg/m². Below 0.1 kg/m² the carbonated layer remains unbroken and the scaling is therefore independent of the pre-conditioning time. Above about 1 kg/m², the skin is totally broken already after a few cycles and the rate of scaling is therefore independent of the pre-conditioning time in this case as well.

All the results presented above are relevant only for Portland cement concrete. Other binders may give other results. In /17/, for example, it is clearly shown that carbonation

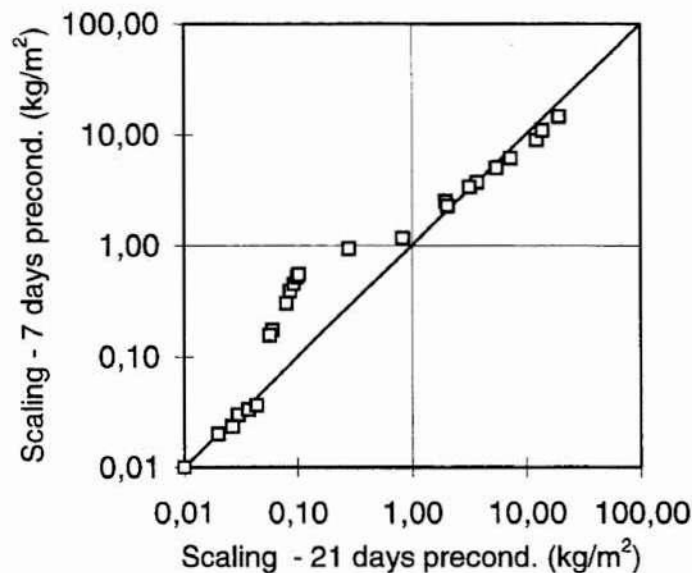

FIGURE 7 Comparison between scaling results for specimens preconditioned for 7 and 21 days respectively /16/.

is *negative* for concrete produced with blast furnace slag cement, where scaling resistance is concerned. The choice of pre-conditioning method, consequently, is very important when rating different concrete qualities using scaling tests. A long pre-conditioning period in air, for example, seems to be positive for Portland cement concrete but negative for concrete produced using blast furnace slag cement.

Scaling resistance testing is performed in order to evaluate two things: the short term scaling resistance during the first months after casting and the long term scaling resistance, relevant for the second winter season after casting and later. It is probably impossible to simulate both these cases using a single pre-conditioning procedure. Probably two procedures need to be used.

For short term resistance, existing pre-conditioning methods may be suitable. These methods normally state one or three weeks pre-conditioning in air, with exactly specified values of the climatic conditions.

To investigate long term resistance, the concrete specimens have to be subjected to some form of ageing. According to the results presented in this paper, carbonation seems to be the most important ageing parameter where scaling resistance is concerned. The total testing period must not be too long. Long term scaling resistance, therefore, should be tested on specimens subjected to accelerated carbonation, for example in an environment with increased carbon dioxide content. It can be assumed that the carbonation rate is approximately proportional to the carbon dioxide content. One week at 3% or three weeks at 1% CO₂ thus corresponds to about two years of outdoor exposure. This seems to be reasonable for predicting the long term scaling resistance. This pre-conditioning method should, of course, not be used until it has been proven to give reliable results, i.e. test results that well correlate with field experience.

Based on the discussion in this chapter, the following recommendations regarding pre-conditioning of specimens for scaling resistance tests can be given:

- *During pre-conditioning, carbonation seems to be the most important factor influencing scaling resistance. To understand the deterioration mechanisms and to develop reliable test methods, it is necessary to learn more about the carbonation process and the properties of the carbonated layer close to the concrete surface.*
- *In order to investigate the short term scaling resistance, i.e. the properties during the first few months after casting, traditional conditioning methods can be used. This means one to three weeks in air, under well defined climatic conditions .*
- *To investigate the long term resistance, the concrete specimens have to be subjected to carbonation. The total testing period must not be too long. Long term scaling resistance, therefore, should be tested on specimens subjected to accelerated carbonation, for example in an environment with increased carbon dioxide content. One week at 3% or three weeks at 1% may be suitable.*

4 SALT SOLUTION

Verbeck and Klieger performed some classical experiments /18/, where they studied the influence of the concentration of different salt solutions on scaling resistance. Results for sodium chloride are presented in figure 8.

According to the results in /18/ there is an optimal salt concentration giving higher scaling values than any other concentration. This concentration seems to be about 3%, independent of the type of salt used. Based on these results, all existing scaling test methods have 3% salt concentration as the standard test solution. The motivation is that this is the most severe case and should lead to results on the safe side.

Verbeck and Klieger's tests were performed on traditional concrete qualities with water/cement ratios around 0.5. It may, therefore, be the case that other salt concentrations are the most severe for other types of concrete, such as very dense, high-performance qualities. This was first discussed in /19/, where theoretical calculations indicated that the most severe concentration increases as the water/cement ratio decreases. These findings were supported by results from experiments carried out by Sellevold and Farstad /20/. According to the test results, the most severe concentration was about 2-3% for concrete with water/cement-ratios around 0.55. For high-strength concrete, with water/cement-ratios below 0.35, however, no optimal salt concentration was found. Scaling increased with increased concentration, at least up to 6%.

The experimental and theoretical experience regarding the influence of salt concentration is limited and it is important that more research is carried out on this subject. Until more is known, a three percent concentration probably is the most suitable

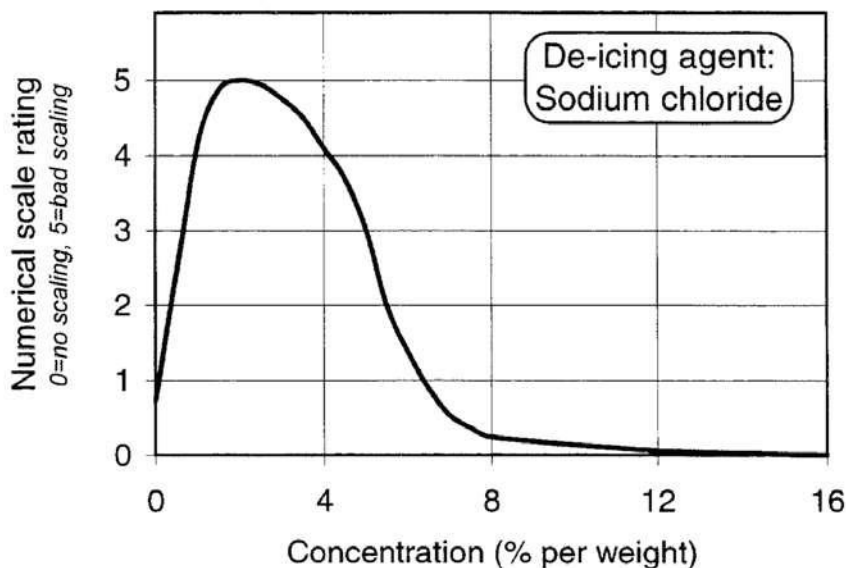

FIGURE 8 Effect of the concentration of the salt solution on the scaling for a non air-entrained concrete quality /18/

choice. However, it is important to be aware of the fact that using this concentration may sometimes lead to overestimation of the scaling resistance of, for example, dense, high-performance concrete qualities.

Sodium chloride is used for the salt solution in most test methods. This salt is probably the best choice for a standard solution as sodium chloride is the most widely used de-icing agent and the major constituent in sea water. Test methods should also, however, allow for using other salts, or other de-icing agents, when appropriate. When testing concrete for runway pavements on airports, for example, urea should normally be used. When testing concrete for the splash zone of marine structures, sea-water can be used, and so on. The choice of the salt for the test solution should be based on the type of environment, to which the concrete will be exposed.

The following recommendations can be given with regard to the choice of the salt solution for scaling resistance testing:

- *There is too little known today about the influence of the salt concentration on scaling resistance. More research is needed.*
- *Based on current knowledge, a three percent concentration is probably the most proper choice. This concentration may, however, sometimes lead to overestimation of the scaling resistance of, for example, dense, high-performance concrete qualities.*
- *The choice of the type of salt to be used for the test solution should be based on the type of environment, to which the concrete will be exposed.*

5 SCALING RESISTANCE TESTING AND STANDARDIZATION

The performance of scaling resistance testing can be divided into two parts: *Manufacturing plus pre-conditioning of test specimens* and *Freeze/thaw testing of specimens*. These two parts should preferably be separated in two standards. This is sometimes the case when testing other concrete properties, for example when testing the compressive strength according to ISO-standards.

The first standard, designed for specimen preparation, should allow for a number of alternatives. The alternative to be chosen will depend on the purpose of the testing. There should be one main alternative for, among other things, normal testing of the potential scaling resistance of concrete. The main alternative should also be used for round robin tests, which should be carried out to evaluate the precision of the method as well as the "skilfulness" of the participating laboratories. Other alternatives should allow for testing drilled cores, testing the effects of curing conditions or surface treatment, etc. The preparation of the specimens should resemble "field conditions" as closely as possible.

The second standard, designed for freeze/thaw testing, should only give information about pure testing parameters, such as the freeze/thaw cycle, the salt solution, the measuring of the scaled material, etc., but no information at all about the preparation of the test surface. Some parameters of the testing procedure should preferably be optional, i.e. alternatives are given in the standard. The final decision of which alternative to be chosen should be made, for example, by the standardisation body in the region where the concrete is to be used.

The minimum temperature is one parameter that could be optional. The main alternative should be -20°C . Other temperatures, for example -10°C and -15°C , can be alternatives for regions where the minimum temperature is never lower than these values. The cooling rate could also be optional, with one main cooling rate and one higher one, useful in some regions with extreme temperature variations. Finally, the choice of salt for the test solution should be optional.

For standardisation, the following recommendations are made:

- *Scaling resistance testing of concrete should be separated in two standards, the first one describing the manufacturing and pre-conditioning of specimens, the second one describing the freeze/thaw testing procedure.*
- *Some test parameters, such as the minimum temperature, the cooling rate and the type of salt in the salt solution, should be optional. This means that there will be alternatives given in the standard for these parameters, and the final choice will be made in the region where the concrete is to be used.*

6 CONCLUSIONS AND RECOMMENDATIONS

Conclusions and recommendations can be found in the boxes at the end of each section. The main conclusions are:

- More research is needed in the field of scaling resistance of concrete. Knowledge about the degradation mechanisms is poor, and there is a need for better understanding of the effects on scaling resistance of parameters such as freeze/thaw cycle, carbonation, salt concentration, etc.
- Scaling-resistance testing should resemble field condition as closely as possible, both in terms of pre-conditioning and freeze/thaw testing.
- Ageing significantly affects scaling resistance. Carbonation seems to be the most dominant ageing parameter. Long term scaling resistance, therefore, should be tested on specimens subjected to accelerated carbonation, for example in an environment with increased carbon dioxide content.

- At standardisation, scaling resistance testing of concrete should be separated into two documents, the first describing the manufacturing and pre-conditioning of specimens, the second describing the freeze/thaw testing procedure.

ACKNOWLEDGEMENTS

During the last twenty years, the author has listened to many interesting lectures given by Professor Fagerlund and also has often discussed problems about scaling resistance of concrete with him. Without this input, the contents of this paper would have been completely different, or the paper would not have been written at all.

7 REFERENCES

- /1/ Petersson, P-E (1986). *The influence of silica fume on the salt frost resistance of concrete*. Swedish National Testing and Research Institute. SP-Report 1986:32, Borås, Sweden.
- /2/ Fagerlund, G (1973). *Critical degree of saturation when testing porous and brittle building materials*. Lund Institute of Technology, Department of Building Technology, report 34 (in Swedish).
- /3/ Fagerlund, G (1971), *Degré critique de saturation - Un outil pour l'estimation de la résistance au gel des matériaux de construction*. Matériaux et Construction, Vol 4, No 23, 271-285.
- /4/ Powers, T C and Helmrath, R A (1953). *Theory of volume changes in hardened Portland cement during freezing*. Highway Research Board, Proceeding No 32, pp 285-316.
- /5/ Powers, T C (1949). *The air-requirement of frost resistant concrete*. Highway Research Board, Proceedings No 29, pp 184-202.
- /6/ Preliminary results (unpublished) from an ongoing European round robin test within the S,M&T-project "Standard Methods for Testing the Resistance of Concrete to Freezing and Thawing" (1997).
- /7/ RILEM TC 117-FDC (1995). *Test Methods for the Freeze/Thaw Resistance of Concrete. Slab Test and Cube Test*. Materials and Structures, Vol 28, No.180, pp. 366-371.
- /8/ RILEM TC 117-FDC (1996). *Test Methods for the Freeze/Thaw Resistance of Concrete with Sodium Chloride Solution(CDF)*. Materials and Structures, Vol 29, No.193, pp.523-528.
- /9/ Petersson, P-E and Lundgren, M (1996). *Influence of the Minimum Temperature on the Scaling Resistance of Concrete*. Proceedings of the Seventh International Conference on Durability of Building Materials and Components (7DBMC), Stockholm 1996, pp 523-531.
- /10/ Studer, W (1993). *Internal Comparative Tests on Frost De-icing Salt Resistance*. Proceedings from the RILEM International workshop on the resistance of

- concrete to scaling due to freezing in presence of de-icing salts. Université Laval, pp 173-187.
- /11/ Lindmark, S (1993). *Influence on the Test Results of Variations in the Salt Concentration, The Salt Distribution and the Freeze/Thaw Cycle when Testing the Scaling Resistance According to SS 13 72 44*. Lund Institute of Technology, Division of Building Materials, report TVBM-7055.
- /12/ Fagerlund, G (1995). *Freeze-Thaw Resistance of Concrete. Destruction mechanisms. Concrete technology. Test methods. Quality control*. Lund Institute of Technology, Report TVBM- 3060, Lund, Sweden.
- /13/ Lundgren, M (1992) *Unpublished results* from tests performed at the Swedish National Testing Institute, SP, Borås, Sweden.
- /14/ Jacobsen S (1995) *Scaling and Cracking in Unsealed Freeze/Thaw Testing of Portland Cement and Silica Fume Concretes*. Norwegian Institute of Technology, Report 1995:101.
- /15/ Utgenannt, P and Petersson, P-E (1997). *Influence of Pre-conditioning on Scaling Resistance for Different Types of Test Surfaces*. Proceedings of the International RILEM Workshop "Frost resistance of concrete", RILEM, Proceedings 34, pp 184-194.
- /16/ Utgenannt, P (1997). *Unpublished results* from an ongoing project at SP, Borås Sweden.
- /17/ Stark, J (1997). *Frost Resistance with and without Salt - a Purely Physical Problem?* Proceedings of the International RILEM Workshop "Frost resistance of concrete", RILEM, Proceedings 34, pp 83-89.
- /18/ Verbeck, G J and Klieger, P (1957). *Studies of salt scaling of concrete*. Highway Research Board, Bulletin 150, pp 1-13, Washington D.C.
- /19/ Petersson, P-E (1984). *Influence of saline environments on the frost resistance of concrete*. Proceedings from a Nordic workshop on Concrete and Frost. Danish Concrete Association, Publication no 22, Copenhagen, pp145-175.
- /20/ Sellevold, E and Farstad, T (1992). *Frost/salt-testing of concrete. Effect of test parameters and concrete moisture history*. Proceedings from a research seminar on Freeze-thaw and de-icing resistance of concrete in Lund in June 1991. Lund Institute of Technology, Report TVBM-3048.

PENETRABILITY OF CEMENT BASED GROUTS



Paul Sandberg

Tekn. Lic.

Cementa AB & Lund Inst. of Technology, Building Materials
S-221 00 Lund
SWEDEN

ABSTRACT

A new method, "NES", for testing the penetrability of grouts for rock injection have been developed by Cementa AB in cooperation with Skanska AB and Elkem ASA Materials. The test method involves the injection of a grout under a specified pressure through a slot with a selected width. The flow of material injected through the slot is recorded by a datalogger. The obtained flow represents the penetrability as measured by this specific test method and can be compared with the penetrability of pure water and with the penetrability of other grouts. The NES method has been used to identify and control the main cement production parameters as well as the main grouting parameters influencing the penetrability of a standard grout.

Key words: Injection, grouting, microcement, penetrability, performance testing

1 INTRODUCTION

The need for performance test methods for the testing and evaluation of materials and grouts for grouting has become evident through several large infrastructure projects which require advanced materials and equipment. Although several methods already exist addressing penetrability, such as the "Filter pump" /1/ and the "Sand column" /2/, Skanska expressed a strong need for a test method addressing more directly the penetrability under pressure through a specified crack/slot width, thus simulating the grouting of rock cracks. The NES method was therefore developed in 1997 by Cementa, Skanska and Elkem Materials within a joint project regarding cement based grouting systems.

This paper is the first in a series of papers presenting the NES method to be written by the inventors Magnus Nelson, Skanska, Tor Ericsson, Cementa and the present author.

2 THE NES APPARATUS

2.1 Experimental set-up

The NES apparatus is shown in Figure 1. A cylinder containing compressed air and a pressure regulator is used to select and maintain a desired injection pressure, in the range of 1-20 bars. The grout to be tested is poured into the grouting cylinder, the exhaust valves are closed and the selected air pressure is applied to the grout which is then forced through the selected slot. The actual slot width tend to vary slightly from one test to another. As a consequence each grout should be tested by sets of two tests and evaluated relative to the performance of pure water injected in the slot.

Several slots with various widths have been manufactured, but only the 50 μm wide slot has been systematically used (at a pressure of 20 bar), as these testing conditions were preferred by Skanska.

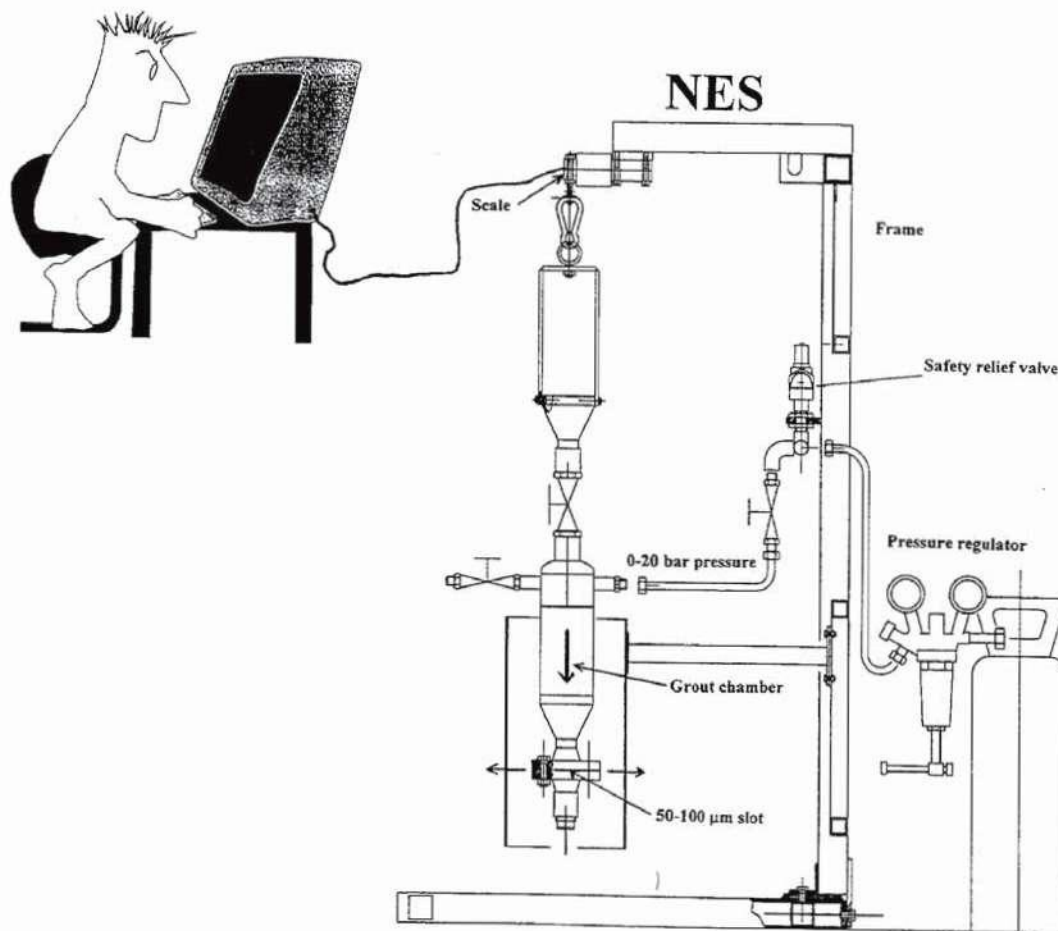

Figure 1. The NES set-up

2.2 Presentation of results

The flow through the NES slot is registered as a weight change using a datalogger as the grout evacuates through the slot, as illustrated in Figure 2. The results can be further processed to represent the volume flow and the relative amount of residue not passing through the slot.

2.3 Reproducibility

The reproducibility has been tested by repeating the NES test for a standard grout four times as illustrated in Figure 2.

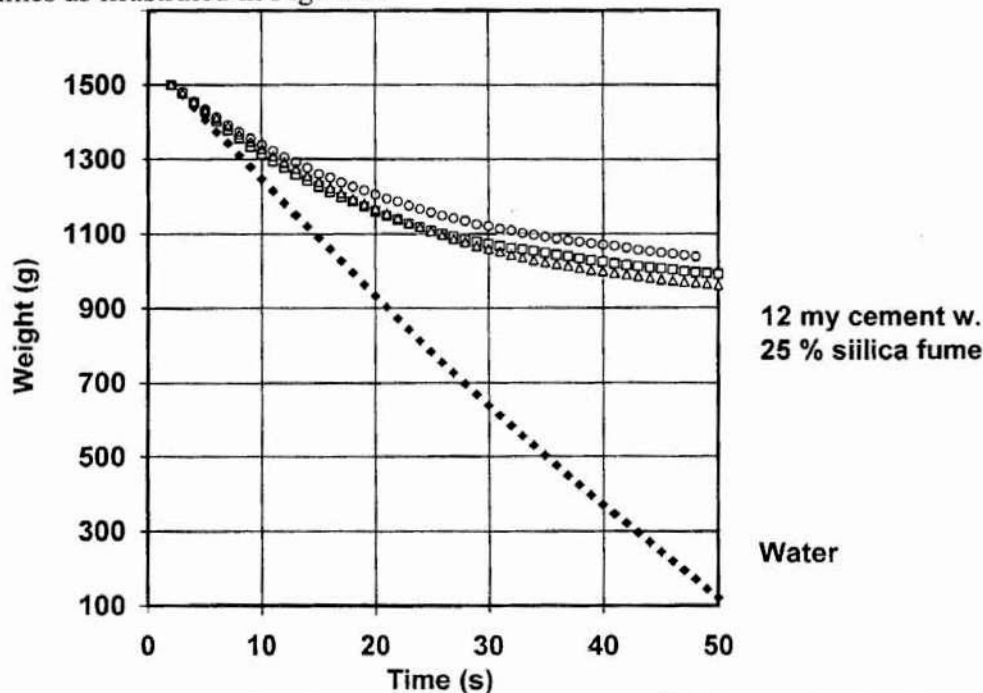

Figure 2. Presentation of results from four repeated NES test of a standard grout, w/c 3,0 and 25% silica fume by weight of binder. A melamine based superplasticiser was used to disperse the grout (0.66% solid superplasticiser by weight of binder).

2.4 Studies of the mechanisms of filter cake formation

The NES set-up provides the possibility to study the particle size distribution and the chemical composition of the filter cake which eventually plugs the slot and thereby controls the individual performance of each grout. This special feature has not yet been utilised fully. However it has been observed that the performance of a grout in the NES test seems to be very much related to its tendency for filter cake formation in the slot.

2.4 Field testing

The NES set-up has been designed to facilitate field testing, at the grouting site or at the cement factory, as well as laboratory testing.

3 THE CONCEPT OF STABLE CEMENT BASED GROUTS

The concept of stable cement based grouts is based on the idea that cement grouts which tend to separate during the grouting process should be less likely to penetrate cracks as compared to stable grouts. A cement slurry based on microcement on the other hand tend to separate significantly if the w/c ratio exceeds 0,8. As the penetrability through a given crack width for a given cement depends on the free space between individual cement grains, a higher w/c ratio would be beneficial as long as the tendency for separation is minimised. As a consequence the use of microcement at w/c ratios higher than 0,8 with the addition of a stabiliser has become more popular at sites dominated by very fine crack systems. As Elkem Materials has developed a silica fume based stabiliser for cement grouting at high w/c ratios, Cementsa and Elkem have co-operated in the development and investigation of stable cement based grouts with the possibility of controlled/reduced setting time, mainly intended for a major railroad tunnel project.

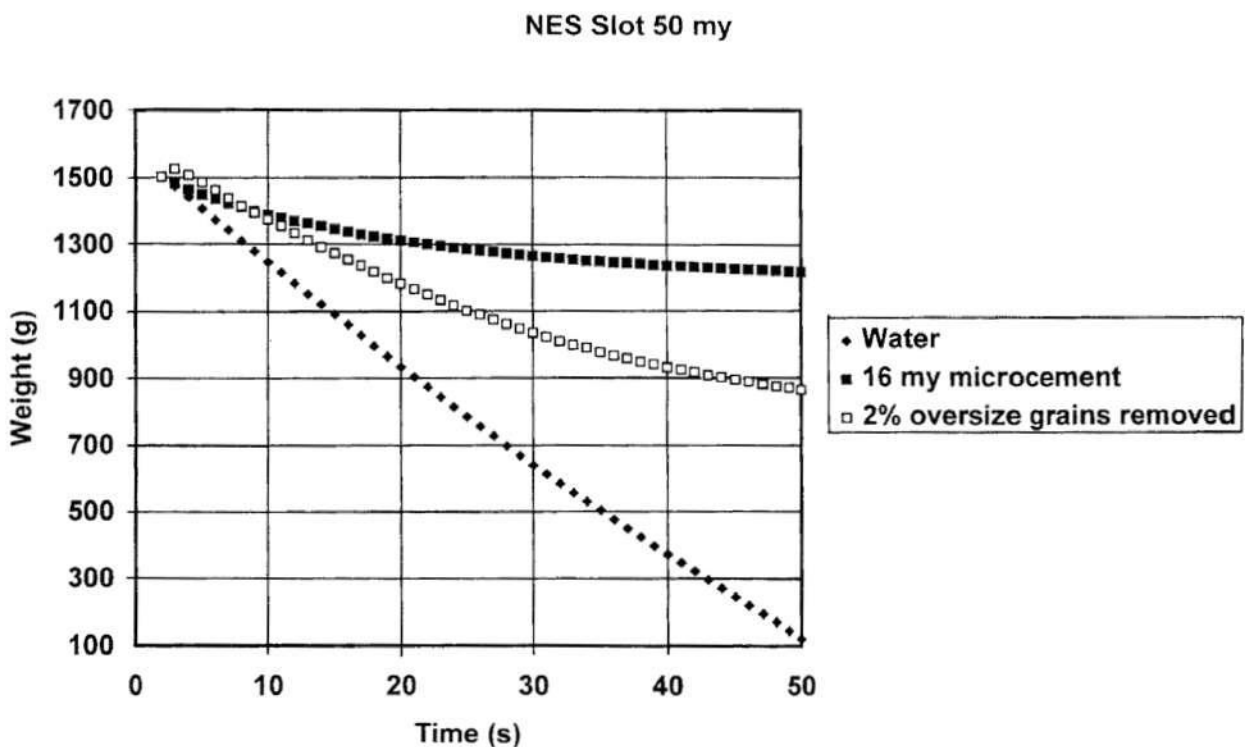

Figure 3. The effect of oversize grains on penetrability in the NES test.

4.3 The effect of mixing performance

The effect of mixing performance was tested by comparing identical grout designs prepared with and without the use of a high shear mixer. The results are shown in Figure 5.

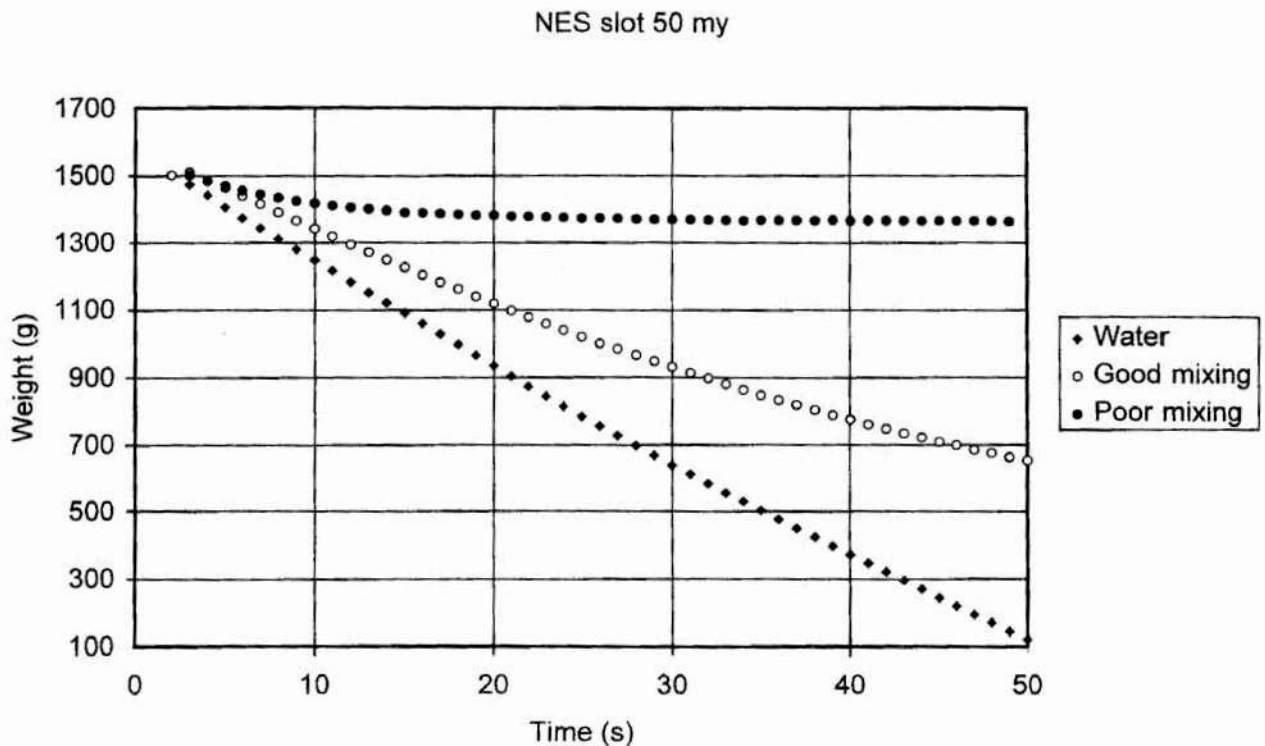

Figure 5. The effect of mixing performance on penetrability in the NES test.

4.4 The effect of sediments in the equipment for mixing and handling

The effect of sediments in the equipment for mixing and handling was tested at a full size mixer which had not been cleaned properly. The effect was very illustrative as the NES slot immediately became completely clogged with sediments, agglomerates etc. from the store tanks and pipes which had not been cleaned properly.

4.4 Influence of accelerators and of cement type

The influence of accelerators and of cement type has been testing by adding either accelerating salts to the mixing water or by adding early reactive aluminat cement (90 % $C_{12}A_7$) to the commercial microcement based on sulfate resisting Portland cement.

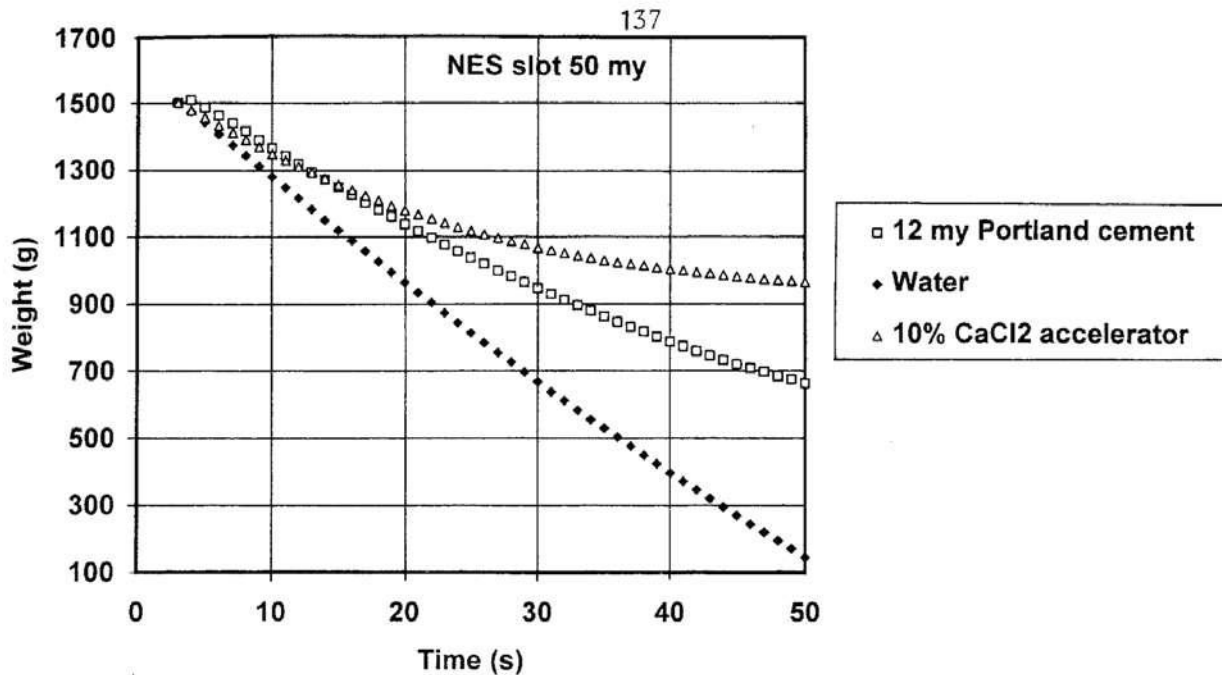

Figure 6. The effect of accelerating salt on penetrability in the NES test.

The effect of accelerating salt is shown in Figure 6. A more extreme acceleration by the addition of 8 % aluminate cement (in order to achieve a rapid gel formation) resulted in an immediate clogging of the NES slot. The negative effect of the early reacting aluminate cement was possible to offset by the addition of a retarder, however this system is complex and needs further study to be fully utilised.

5 THE SIGNIFICANCE OF THE NES METHOD AND OF ACHIEVED RESULTS

The development of the NES method was initiated by Magnus Nelson at Skanska as field experience from the Hallandsås tunnel indicated that a method for testing and evaluating penetrability in a crack was urgently needed. However it is at this stage not possible and not desirable to claim that the NES method should be more relevant than other methods; The NES method is merely a complement to existing methods as it may represent an extreme situation with a high pressure gradient and a single crack. If the pressure is high the slot may be slightly deformed during the test, but still the main principle should be correct as a material which penetrates the slot more readily than another should also perform better in the field - if the slot width is relevant to the characteristic crack size in the rock.

It is evident from the NES results that oversize cement grains, Figure 3-4, or insufficiently mixed grouts, Figure 5, or sediments from old batches, will have very negative effects on the penetrability of a grout. The results imply that it is extremely important to control the amount of oversized cement grains, as well as the amount of agglomerates in the silica fume. Colloidal particles as silica fume have a tendency to agglomerate and to sediment over time, which implies that silica fume should not be stored at the site without periodical agitation.

It is equally important to clean the grouting equipment, mixes, tanks etc. thoroughly after use. If the grout is insufficiently mixed or contaminated with old sediments, the performance will be poor no matter how good the raw materials are. The NES results also indicate that measures aimed at accelerating the setting time generally has a negative effect on the penetrability of a given grout. This is apparently because accelerators are generally easily soluble and therefore start to accelerate the cement hydration before the grouting has been completed. Probably the best way to overcome this problem is to add the accelerator as late as possible just before the grout enters the crack/slot. Accelerators could preferably be added at the nozzle, but so far this option has been regarded as impractical by end users.

The NES results indicate that with a more finely ground microcement the w/c ratio can be decreased substantially because of the greatly improved penetrability at a given w/c ratio. If this result is applicable in the field, one of the most efficient ways of improving the setting time would be to use a lower w/c ratio, which in turn would require a more finely ground cement.

6 FUTURE DEVELOPMENTS

As almost no systematic scientific research has been carried out on the NES method, there are several topics to investigate and probably several improvements to consider. A few obvious topics are:

- Physical and chemical compositions of filter cakes formed. Mechanisms of filter cake formation. Cement- and silica fume properties related to the formation of filter cakes.
- Calibration of slot sizes to characteristic crack widths in the field. Characterisation of grout designs, particle size distributions, cement types, etc. for various crack systems.
- Development of cements and/or accelerators which facilitate a relatively rapid setting time without major negative effects on the penetrability of the grout.
- Theoretical modelling of the clogging of a crack and the flow of grout through it.

7 REFERENCES

1. Hansson P. Filtration Stability of Cement Grouts for Injection of Concrete Structures. Proc. IABSE Symp. Extending the Lifespan of Structures, pp 1199-1204, San Fransisco 1995.
2. Jørgensen O, Fidjestøl P. Improvements in Grouting Technology using Microsilica. Proc Int Symp Rock Support, Lillehammer, June 22-25 1997.

SERVICE LIFE PREDICTION OF REINFORCED CONCRETE STRUCTURES IN SALINE ENVIRONMENT



Paul Sandberg
Tekn Lic.
Cementa AB & Lund Inst. of Technology, Building Materials
S-221 00 Lund
SWEDEN

ABSTRACT

A general system for service life prediction of reinforced concrete structures with respect to chloride initiated reinforcement corrosion was outlined. The system involves
i) the prediction of the initiation time in uncracked concrete,
ii) the prediction of the permissible time of active corrosion - the propagation time - in cracks < 0.4 mm wide. The predicted service life is suggested as the shortest of the two predicted times.

Key words: Service life prediction, chloride induced reinforcement corrosion, chloride transport, corrosion rates, cracks

1 INTRODUCTION

The service life of reinforced concrete with respect to chloride initiated pitting corrosion can be schematically described by the Initiation-Propagation model presented by Tuutti /1/, Figure 1.

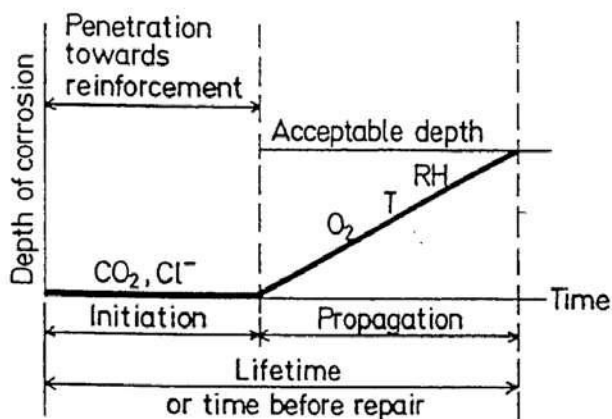

Figure 1. The Initiation - Propagation model /1/.

The initiation period for a given concrete quality with a given cover thickness is determined by the chloride transport rate through the cover, and the concentration of chlorides required to destroy the normal passivity of steel in sound concrete.

The chloride transport rate in uncracked concrete depends on the concrete quality - mainly the w/c ratio and the type of binder - and on the exposure conditions /2/. The critical chloride concentration, the chloride threshold level, reflects the critical concentration of chloride ions in the concrete pore solution at the reinforcement, but it is for practical reasons often expressed as the total chloride content by weight of cement. The chloride threshold level as well depends on the w/c ratio, the type of binder and the exposure conditions - mainly the amount of oxygen available at the reinforcement /2/.

The initiation period in an open crack more than 0.2 mm wide which reaches the reinforcement is considerably shorter than in uncracked concrete. In most practical applications the initiation period in such cracks reaching the reinforcement can be assumed to be "zero" (or a few years), as the chloride transport rate is fast and the chloride threshold level close to zero in the crack /3/.

1.1 Prediction of the initiation time in uncracked concrete

Several systems for prediction of the initiation time in uncracked concrete has been proposed since 1970 /4/ using solutions to Fick's second law of diffusion for describing chloride transport. The more recent systems /5/ models the time dependency and the effect of exposure conditions on the chloride transport rate.

1.2 Prediction of the permissible time of active chloride initiated pitting corrosion in cracks

Little or no experimental data exists on the permissible cross section reduction of corroding reinforcement subjected to chloride initiated pitting corrosion for various types of concrete structural parts. At this stage it has therefore been generally hypothesised that the service life is over when a maximum of 20 % of the reinforcement cross section area has been lost in a crack. The maximum permissible loss of cross section area should preferably be calculated for various structural parts by relevant experts in construction and then experimentally verified in large scale corrosion tests on concrete structural parts under relevant loads.

Experimental studies of the propagation rate in high performance concrete with cracks wider than 0.1 mm exposed for seawater or de-icing salts have been carried out within the Swedish project on High Performance Concrete Structures /6/. The results on loss of reinforcement cross section area at corrosion pits in cracked concrete have been used by K. Pettersson /7/ at CBI to calculate the time to reach a 20 % loss of cross section area as shown in Figure 2 for ordinary reinforcement.

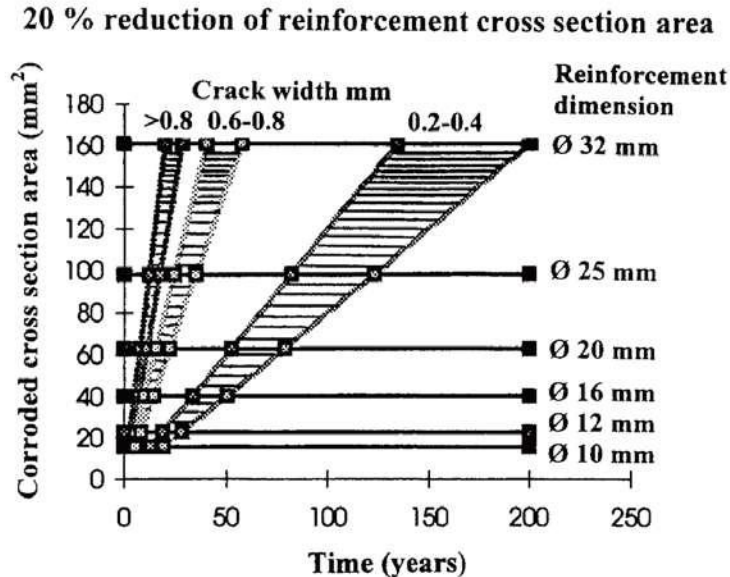

Figure 2. Calculated propagation times in marine exposed high performance concrete with a maximum of 20% loss of the reinforcement cross section area within the service life. Corrosion rate based on 2 years field exposure tests at Kristiansand.

2 COMBINATION OF PREDICTED INITIATION- AND PROPAGATION TIME TO A SERVICE LIFE MODEL

2.1 General

Most concrete structures have crack widths > 0.2 mm as a result of shrinkage, structural loads, etc. A model for service life prediction of reinforced concrete should therefore require a prediction of the corrosion status in both uncracked concrete and at neighbouring cracks wider than 0.2 mm.

The following assumptions have been made for the sake of simplicity:

- A) Concrete with crack widths ≤ 0.2 mm are regarded as crack free.
- B) The service life is ended if corrosion of the reinforcement leads to spalling of the cover.
- C) The concrete cover should always be a minimum of 25 mm in saline environment. Experimental studies /3,5,6,7/ in marine environment have indicated that
 - i) the chloride threshold level in uncracked concrete is significantly lower in a concrete with 10 mm cover as compared to 20 mm cover and thicker
 - ii) the corrosion rate in cracked concrete is significantly lower in a concrete with 30 mm cover as compared to 15 mm cover and thinner.
- D) The propagation time is very small as compared to the initiation time for uncracked concrete exposed to the atmosphere with a minimum of 25 mm cover, because
 - i) active corrosion in normal concrete, $w/c > 0.40$, is relatively fast and may lead to spalling of the cover within a few years of active corrosion.

ii) active corrosion in high performance concrete, $w/c \leq 0.40$, may be very slow due to the very high resistivity of the concrete, but the very low porosity and the high fragility of high performance concrete may still result in spalling of the cover within a few years of active corrosion.

E) The chloride threshold level in uncracked high performance concrete would not be significantly affected by an active corrosion in nearby cracks, because of the high resistivity of high performance concrete.

F) In uncracked normal concrete the chloride threshold level would be affected (increased) by the localised cathodic protection provided by rapid corrosion in nearby cracks.

G) Spalling of concrete cover does not occur in underwater concrete because the lack of oxygen for the formation of expansive rust.

2.2 Classification of corrosion modes

A small number of corrosion modes would describe in principle the service life of most reinforced concrete with the aid of the assumptions made above:

2.2.1 Corrosion in uncracked concrete exposed to the atmosphere (mode 1)

The service life of uncracked concrete in a saline oxygen rich environment was illustrated in Figure 3. The chloride threshold level is relatively low as the availability of oxygen is high. Once active general corrosion is initiated, the corrosion products formed are expansive and the remaining propagation time until spalling occurs is very short compared to the initiation time.

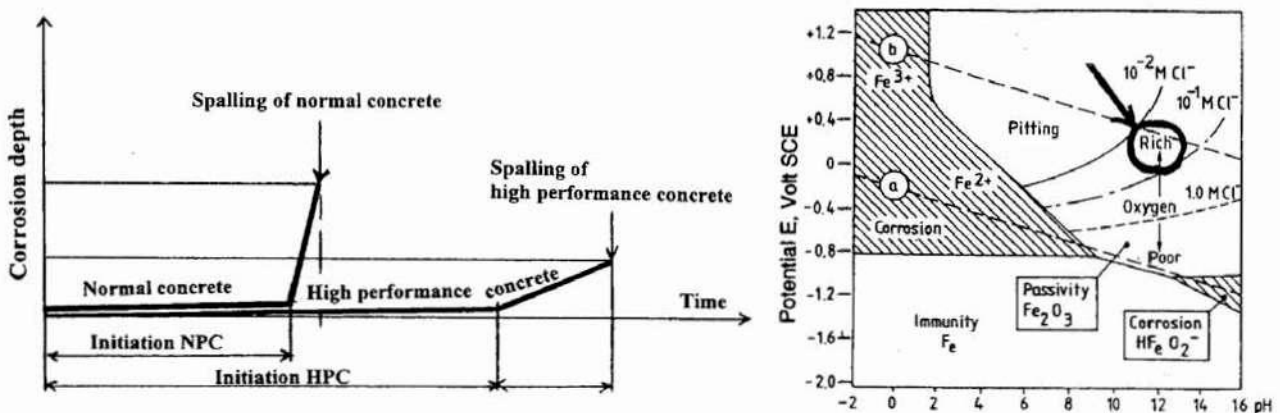

Figure 3. The service life of uncracked concrete exposed in the atmosphere.

This corrosion mode applies to normal (NPC) and high performance (HPC) concrete. In normal concrete active corrosion is relatively fast. In high performance concrete active corrosion may be very slow, but the very low porosity and the high fragility allow for very little amounts of expansive rust to form without spalling.

However it is important to recognise the very slow chloride transport rate in high performance concrete. A high performance concrete would require substantially less cover thickness for a given initiation time!

Assumption: Service life \approx initiation time for uncracked parts of concrete with cracks ≤ 0.2 mm wide exposed in the atmosphere.

2.2.2 Corrosion in cracked concrete exposed to the atmosphere (mode 2)

The service life of cracked concrete in a saline oxygen rich environment is illustrated in Figure 4 for cracks > 0.2 mm wide. The initiation time is often close to zero if the crack reaches the reinforcement. The availability of oxygen is very high and the corrosion rate is anodically controlled by the clogging of corrosion products in the crack. The corrosion products clogging the crack do not cause spalling of the cover.

The uncracked parts of the structure follows mode 1. The service life of the combined cracked and uncracked concrete will be determined by the shortest of the initiation time in the uncracked part according to mode 1 and the propagation time in the crack according to mode 2. Once active general corrosion is initiated in uncracked concrete, the corrosion products formed are expansive and the remaining propagation time until spalling occurs is very short.

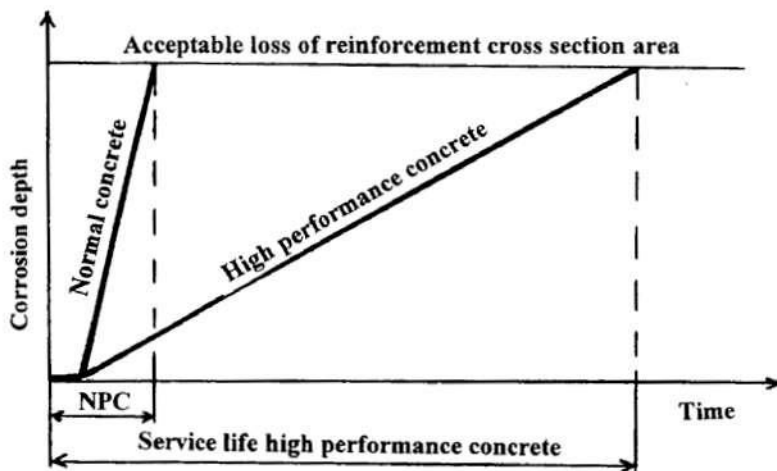

Figure 4. The service life of cracked concrete exposed in the atmosphere.

This corrosion mode applies to normal and high performance concrete. In normal concrete active corrosion is fast once initiated in cracks as well as in uncracked concrete. In high performance concrete the chloride transport rate is very slow in uncracked concrete, and the active corrosion in cracks is very slow, which may lead to a very long service life also with moderate covers.

Assumption: Service life \approx the shortest time of i) the initiation time in uncracked concrete ii) the propagation time at cracks

for normal and high performance concrete with cracks > 0.2 mm wide exposed in the atmosphere.

2.2.3 Corrosion in uncracked concrete fully exposed under water (mode 3)

The service life of uncracked concrete in a saline oxygen free environment (> 5 m below the sea level) is illustrated in Figure 5. The chloride threshold can be very low as the amount of oxygen available is insufficient to maintain passivity of steel. Thus active general corrosion may be initiated also in the absence of chlorides. However, in the absence of oxygen pitting corrosion cannot initiate, the corrosion products are not expansive and the corrosion rate is extremely slow. The propagation time is therefore too long to be predicted.

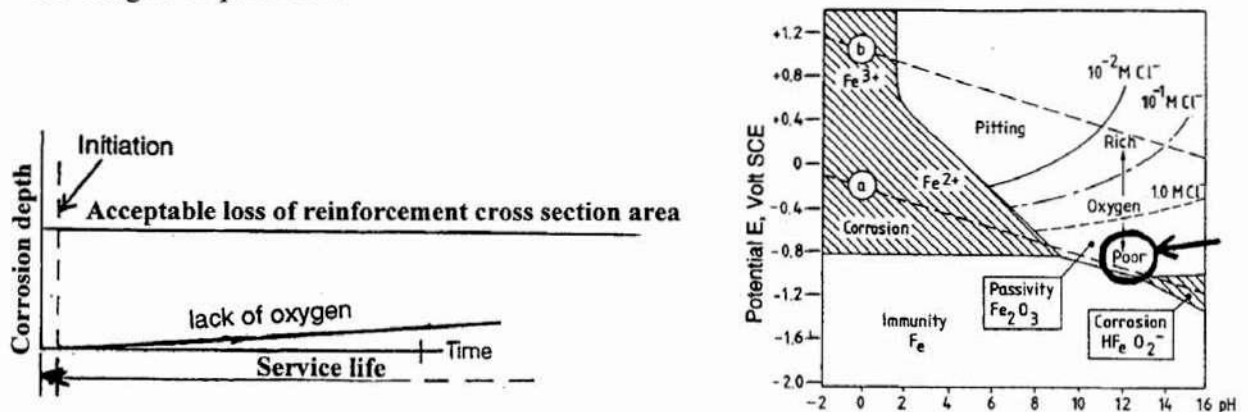

Figure 5. The service life of uncracked concrete fully exposed under water.

This corrosion mode applies to normal and high performance concrete. It does not apply at depths < 5 m below the sea level if parts of the reinforcement system can act as a cathode in concrete exposed to the atmosphere, as rapid macro cell corrosion may develop. Macrocell corrosion is represented by mode 2, with the difference that less corrosion products will precipitate and clog the crack. As a consequence the corrosion rate may remain very high throughout the propagation stage. Macrocell corrosion is considerably less rapid in high performance concrete as the high resistivity reduces the distance between possible anode and cathode sites.

Corrosion mode 3 also applies to cracked normal and high performance concrete if the concrete is fully submerged > 5 m below the sea level. Under these conditions macro cell corrosion cannot develop as a consequence of the lack of oxygen

Assumption: Service life for fully submerged concrete is extremely long as the long as the availability of oxygen is too low to initiate macro cell corrosion.

3 EXAMPLES OF SERVICE LIFE PREDICTION OF REINFORCED CONCRETE EXPOSED IN A SALINE ENVIRONMENT

3.1 General

Concrete structures are inhomogeneous by nature on the micro level. Furthermore, the micro climate, mainly salt, wind and moisture exposure, varies extensively from one exposure site to another. Chloride transport coefficients, surface chloride concentrations, threshold levels and corrosion rates therefore vary extensively as illustrated by Thomas /8/ with respect to corrosion rates and threshold levels for marine concrete exposed in the splash zone, Figure 6.

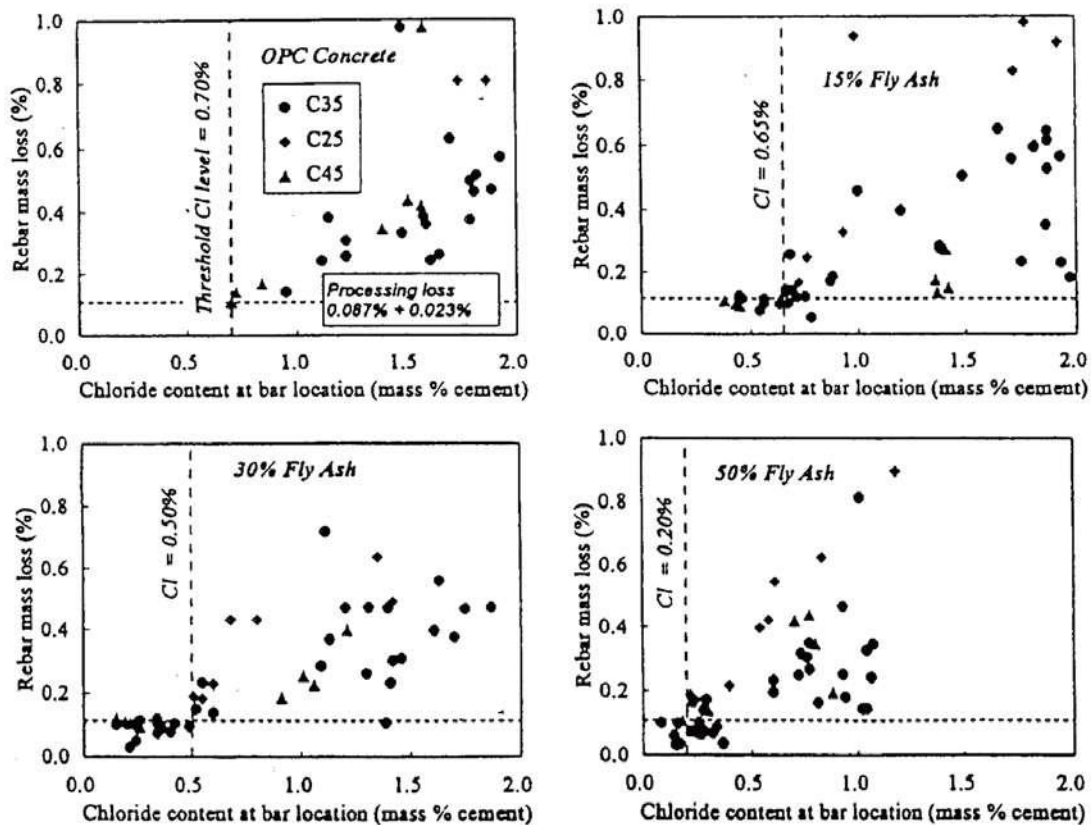

Figure 6. Corrosion activity vs. chloride content at the reinforcement for marine concrete exposed in the splash zone /8/.

From a modelling point of view it would be recommended to evaluate statistically as far as possible all corresponding data with the aim to present the statistical distribution of data. Thus a fractile value can be selected and used for the service life calculation. At this point no statistical evaluation of available data has been carried out, mainly because data has been evaluated from experimental work in different ways by different researchers. On the other hand substantial amounts of data are available in the literature. The following sets of data has been used in this paper:

Table 1 Estimated chloride threshold values, % Cl by weight of cement in crack free concrete. /2,3,7,8,9/.

Exposure zone	Cover mm	Max. w/c ratio	100% CEM I	10% Silica fume	15% Fly ash	15% granulated slag
Atmosphere	25-40	0.45	0.7	0.4	0.5	0.5
Submerged	25-40	0.45	1.5	0.8	1.0	1.
De-icing salt splash zone	35-65	0.40	0.8	0.	0.6	0.6
Marine splash zone	35-65	0.40	0.6	0.3	0.4	0.4

Table 2 Chloride transport coefficients "D_{eff}Cl" (m²/s x 10⁻¹²) as evaluated using Fick's second law for crack free concrete /2,5,10,12,15/. CEM I = Portland cement SF = Silica fume, FA = Fly ash

Exposure zone	Submerged		Marine splash zone		De-icing salt splash zone		Atmospheric zone	
	D _{eff} Cl	Exp. time (yrs)	D _{eff} Cl	Exp. time (yrs)	D _{eff} Cl	Exp. time (yrs)	D _{eff} Cl	Exp. time (yrs)
w/c 0,50								
100 % CEM I	4-7	2	2-4	2			2-3	2
			0,1-2	10-15	2-4	20-30	0,1-1	15-20
			0,1-1	30-40	0,5-2	30-40		
5-10 % SF	2-4	2	1-3	2			1-2	2
	1-2	5-8	0,5-1	5-8				
10-20 % FA	2-6	2	3-5	2			1-2	2
	1-2	5-8	1-3	5-8			0,1-0,7	15-20
w/c 0,40								
100 % CEM I	2-4	2	1-3	2			1-2	2
			0,5-2	5				
			0,5-1	10-15	0,5-2	20-30		
			0,2-0,5	30-40	0,1-0,8	30-40		
5-10 % SF	0,5-2	2	0,5-1	2			0,3-0,8	2
	0,5-1	5-8	0,2-0,5	5-8				
10-20 % FA	0,5-3	2	0,6-2	2			0,6-2	2
	0,5-2	5-8	0,5-3	5-8			0,1-0,3	4

Maximum chloride load close to the exposed concrete surface

Predictions of the chloride ingress in concrete over time requires knowledge or at least an estimation of the outer chloride concentration triggering the chloride transport into the concrete. Unfortunately the total chloride content at the surface is not representative as carbonation and wetting - drying may cause chloride profiles with a chloride maximum at 5-10 mm depth below the surface. Thus it is only in concrete further deeper than the chloride maximum that diffusion based models can be used for prediction of chloride transport in concrete /16/.

It is suggested that the outer chloride load triggering the chloride transport in concrete can be represented by the chloride maximum at or close to the concrete surface, as shown in Table 3.

Table 3 Maximum chloride concentrations " C_{max} " (by weight of concrete) in field exposed concrete at or close to the concrete surface /2,5,10,11,12,13,14,15/.
CEM I = Portland cement SF = Silica fume, FA = Fly ash

Exposure zone	Submerged		Marine splash zone		De-icing salt splash zone		Atmospheric zone	
	C_{max} %	Exp. time (yrs)	C_{max} %	Exp. time (yrs)	C_{max} %	Exp. time (yrs)	C_{max} %	Exp. time (yrs)
w/c 0,50								
100 % CEM I	0,5-0,9	2	0,3-0,5	4	0,1-0,5	1	0,1-0,3	2
	0,6-1,0	5-20	0,2-1,0	10-15			0,1-0,5	15-20
	1,8	100	0,5-1,3	15-20	0,2-1,0	20-40		
5-10 % SF	0,5-1,0	2	0,3-0,9	2	0,2-0,6	40-50	0,2-0,4	2
	0,5-1,2	5-8	0,3-0,5	5-8				
10-20 % FA		2	0,5-0,8	4				2
		5-10	0,8-1,2	5-10			0,1-0,8	15-20
w/c 0,40								
100 % CEM I	0,5-0,8	2	0,2-0,4	2			0,1-0,2	2
	0,5-1,0	5-20						
			0,2-1,0	10-15	0,1-0,6	20-30		
			0,2-1,1	20-40	0,1-0,6	30-40		
5-10 % SF	0,6-0,9	2	0,2-0,4	2			0,1-0,3	2
		5-8		5-8				
10-20 % FA	0,5-0,8	2	0,3-0,6	2			0,1-0,3	2
		5-8		5-8			0,1-0,3	4

Corrosion rates in cracked high performance concrete

Field studies of cracked high performance concrete exposed in a marine splash zone have resulted in the following corrosion rates based on gravimetric and electro-chemical studies of the corroded reinforcement and geometric studies of the corroded surface area, Table 4 /6,7,9/.

Table 4. Corrosion rates mm/year in corrosion pits measured in high performance concrete with 0.4 mm wide cracks and 30 mm cover, exposed 1993 - 97 in a marine splash zone /17/.

W/c ratio	100% CEM I	5 % Silica fume	10 % Silica fume	5% Fly ash	25% Fly ash
0.25	-	0.1 - 0.5	-	-	-
0.30	0.2-0.8	0,08-0,3	0,06-0,2	0.1-0.5	0,06-0,3
0.40	-	0.2-0.8	-	-	-

These results was used to calculate the pitting corrosion rates shown previously in Figure 2, with the following assumptions:

- A) The corrosion pit develops uniformly within a surface area of 25 - 100 mm². The larger the corroded surface area, the smaller is the reduction of cross section area. This assumption probably underestimates the reduction in cross section area as the corrosion pit is usually concentrated to a fraction of the total corroded area at a crack.
- B) The *total* corrosion rate per year is relatively constant over time, as indicated by five years field studies /17/ of
- C) The cross section reduction of the reinforcement is linear over time. This assumption probably overestimates the reduction in cross section area as it was generally observed /17/ that the corrosion pits tend to spread over a larger surface area over time. Thus the cross section reduction should decrease over time as the corrosion attack spreads over a wider surface.

3.2 Uncracked concrete exposed in a marine splash zone (mode 1)

Example:

Calculate the required cover for 100 years of service life for a modern bridge concrete, w/c 0,40 with 5 % silica fume. The concrete is uncracked. Assumption: Service life \approx initiation time for uncracked parts of concrete with cracks ≤ 0.2 mm wide exposed in the atmosphere.

Input data was selected or interpolated from Table 1-3 as shown in Table 5:

Table 5. Input data, uncracked concrete w/c 0,30, 400 kg cement and 21 kg silica fume per m³ concrete exposed in a marine splash zone

Concrete age (years)	C _{max} % by weight of concrete	D _{eff} Cl (m ² /s x 10 ⁻¹²)	C _{crit} % by weight of cement / concrete
0-2	0,3	0,8	0.5 / 0.10
2-5	0,4	0,5	
5-10	0,5	0,4	
10-20	0,6	0,3	
20-40	0,7	0,2	
40-100	0,8	0,1	

Note: The explanation for the decreasing D_{eff}Cl over time is not yet fully understood. Several mechanisms interact. During the first years of service the chloride penetration is mainly taking part close to the surface. Capillary suction probably plays an important role in the outermost 5 mm, thus leading to relatively fast water and chloride transport close to the surface.

The interior part of the concrete is little affected by capillary suction. Here self desiccation and possible other mechanisms play an important role in lowering the internal moisture content. Studies of concrete structures exposed in a marine splash zone /13/ have indicated that the internal concrete is surprisingly dry, with RH in the range of 75 - 85 % and degree of capillary saturation in the range of 0.75 - 0.85.

Calculation method: C_{max} and D_{eff}Cl were assumed to be constant within the time periods given in Table 5. For the first time period the predicted chloride profile was calculated according to the error-function solution to Fick's second law of diffusion:

$$C(x,t) = C_i + (C_{sa} - C_i) \operatorname{erfc} \frac{x}{\sqrt{4(t-t_{ex})D}} \quad \text{Eq. 1}$$

Where

$C(x,t)$ = Chloride concentration in concrete at the depth x from C_{max} at the time t.

C_i = Chloride content in unexposed concrete

C_{sa} = C_{max} = Maximum chloride concentration close to the concrete surface

$\operatorname{erfc}(z)$ = Error function

x = Depth from C_{max}

t = Time from casting

t_{ex} = Exposure time

D = Diffusion coefficient

The achieved chloride profile was then fitted to the C_{\max} and D_{effCl} given for the next period to calculate a new chloride profile. The procedure was repeated until 10 years exposure time. C_{\max} was assumed to be located no more than 5 mm below the surface as the depth of carbonation and the depth of capillary suction is very small for this concrete when exposed in a marine environment. Thus 5 mm was added to the achieved penetration depth of the chloride threshold.

Result: $45 + 5 \text{ mm} = 50 \text{ mm}$

3.3 Concrete with 0.4 mm wide cracks exposed in a marine splash zone (mode 2)

Example:

Calculate the required cover and reinforcement diameter for 100 years of service life for a modern bridge concrete, w/c 0,40 with 5 % silica fume. The concrete has max. 0.4 mm wide cracks. Assumption: Service life \approx the shortest time of i) the initiation time in uncracked concrete ii) the propagation time at cracks, for normal and high performance concrete with cracks $> 0.2 \text{ mm}$ wide exposed in the atmosphere.

This calculation involves 2 steps, the prediction of the initiation time in uncracked concrete and the prediction of the permissible propagation time in cracked concrete. The first step, the prediction of the initiation time in uncracked concrete is the same as in 3.2 (mode 1) above, with the result 50 mm cover required.

The propagation time can be estimated from Figure 2 with the assumption that a maximum of 20 % reduction of the reinforcement cross section area can be accepted.

Result: $\emptyset 25 \text{ mm}$ reinforcement would be required for a 100 years propagation time with max. 20 % reduction of the reinforcement cross section area.

Note: The cross section reductions (e.g. corrosion rates) shown in Figure 2 are based on macro cell corrosion rates in cracks just below the water level. Field studies of the corrosion state in cracked concrete exposed above the water level or in a de-icing salt splash zone have indicated that the corrosion rate is substantially slower above the water level as the concrete cracks are dryer and clogged by corrosion products. Unfortunately no relevant data is available to update the information in Figure 2, which has been used only with the purpose to illustrate the prediction method.

4 DISCUSSION

A general methodology has been outlined for the service life prediction of reinforced concrete with respect to chloride initiated reinforcement corrosion. The prediction method used for chloride penetration in uncracked concrete is probably more accurate as compared to the prediction method used for the corrosion rate in concrete cracks, as a substantial amount of chloride profiles measured in field exposed concrete can be found in the literature. The mechanisms of chloride transport however needs to be clarified, probably in combination with the mechanisms of moisture transport. Furthermore, there is still a lack of long term information for modern and high performance concrete with w/c ratios below 0.4.

A prediction method based on the penetration of free chloride ions and on a chloride threshold expressed by free chloride and hydroxide ions would be scientifically appreciated. For water saturated submerged concrete this is possible as the exterior chloride concentration is constant and the hydroxide leaching rate can be estimated as similar to the chloride penetration rate. But for concrete exposed for wetting and drying, where most of the corrosion problems occur, it is impossible or at least very difficult to measure the concentration of free chloride- and hydroxide ions with any accuracy.

The prediction method used for the corrosion rate in concrete cracks is undoubtedly not quantitative as relevant data are lacking except for the undesirable case of macro cell corrosion in cracked concrete exposed partly submerged in seawater.

5 REFERENCES

- 1 Tuutti K. Corrosion of steel in concrete. Stockholm 1982. CBI Research for 4.82.
- 2 Sandberg P. Critical evaluation of factors affecting reinforcement corrosion in concrete. Lund, 1995. Lund Institute of Technology, Building Materials, TVBM-3068.
- 3 Pettersson K & Sandberg P. Chloride Threshold Levels and Corrosion Rates in Cracked High Performance Concrete Exposed in a Marine Environment. Proc. 4th CANMET/ACI Int. Conf. on Durability of Concrete, Sydney, Australia, August 17-22, 1997.
- 4 Collepari M, Marcialis A & Turriziani R. The kinetics of chloride ion penetration in concrete (in Italian). *Il Cemento*, Vol 67, pp 157-164.
- 5 Nilsson L-O, Poulsen E, Sandberg P, Sørensen H E & Klinghoffer O. A system for the prediction of chloride ingress and corrosion in concrete. HETEK, The Danish Road Directorate, Report No. 83, 1997.
- 6 Pettersson K. Criteria for cracks in connection with corrosion in high performance concrete. Proc. 4th CANMET/ACI Int. Symp. on Utilization of High Strength / High Performance Concrete, Paris 1996.
- 7 High Performance Concrete Manual (in Swedish), Ch 14. In press.

- 8 Thomas M. Chloride thresholds in marine concrete. *Cement & Concrete Research*, Vol. 26, No. 4, pp 513-519.
- 9 Pettersson K. *Service Life of Concrete Structures - In saline environment*. Stockholm 1996. CBI Report 3:96.
- 10 Henriksen C, Stoltzner, E & Lauridsen J. Chloride induced corrosion. Investigations of chloride loads and corrosion status in Danish bridge columns (In Danish). *Vejdirektoratet, København*, 1991.
- 11 Karlsson F, Steorn B & Wannerberg, C (1990). Reinforcement corrosion in concrete bridge columns exposed to salt (In Swedish). Stockholm 1990. BFR R24:1990.
- 12 Mangat P S & Molloy B T. Prediction of long term chloride concentration in concrete. *Materials and Structures*, vol 27, sid 338-346, 1994.
- 13 Andersen A. *Moisture and Chloride Profiles in a Column in the Vejle Fjord Bridge after 18 years of Exposure to Marine Environment*. Work report Chalmers, Gothenburg 1996
- 14 Andersen A. Investigation of chloride penetration into bridge columns exposed to de-icing salt. HETEK Report No. 82, Danish Road Directorate, Copenhagen 1997
- 15 Statens Vegvesen. Durability of marine concrete bridges (In Norwegian) *Vegdirektoratets Bruavdelning / Norges Byggeforskningsinstitut*, 1993.
- 16 Sandberg P. Durability of marine concrete bridges (In Swedish). Lund Institute of Technology, Building Materials, Report TVBM-7035, 1992.
- 17 Pettersson, K. Unpublished results on the geometry and the growth rate of corrosion pits in cracked high performance concrete exposed partly submerged in Kristiansand harbour.

A VISION OF SUSTAINABLE MATERIALS AND STRUCTURAL ENGINEERING



Asko Sarja
 Dr. Tech., Research Professor
 Technical Research Centre of Finland (VTT)
 P.O. Box 1800
 FIN-02044 VTT
 FINLAND

ABSTRACT

The general goals and descriptions of sustainable construction have to be interpreted in terms of technical goals and finally in technologies and methods. For this aim the central factors of the sustainability in materials and structural engineering are identified. In order to improve those key factors, needs, ideas and some solution models have been presented for materials and structural research and engineering.

Key words: Sustainability, materials, structures, life cycle engineering, life cycle design

1 BACKGROUND

The awareness of the environment and ecology in the long term development of construction has increased during the last few years all over the world. For this goal the real content and methodology of sustainability must be concretised and put into practice through the development of design, materials and structures, manufacturing methods and site construction methods. This means a long-term development process where product development and the development of design methods are the most important links introducing the environmental sustainability principles as well as systematic methods of analysis, optimisation and decision-making to all construction partners taking into account the entire life cycle and the recycling of the buildings, technical product systems, components and materials. The real technology is changing through the long-term development of building systems, building concepts and building products. This kind of evolution will make possible the construction of buildings, which are economical and ecological in their life time having a good future value.

The key point in understanding the concrete content of sustainable building is the interpretation of the general principles in the practice of construction.. This means, that we must recognise different aspects of sustainability in building and integrate them

into a comprehensive set of general requirements and further into more detailed specifications. Construction's physical relation to nature increases the requirements of ecology, health and physical environment. The internal sustainability within the society and within the building sector increase the requirements of economy, functionality, performance, durability and aesthetics. Thus we are realising the scheme presented in Fig. 1 (Sarja, 1996). Sustainability must always be treated with life cycle principle, which means the application of life cycle methodology in design, manufacturing, construction, maintenance and management of building projects, companies and of other organisations of building partners.

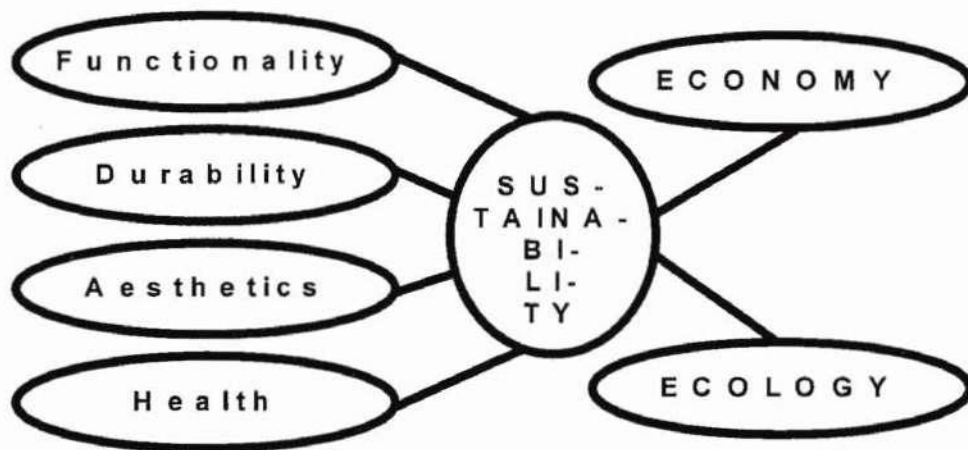

Fig. 1. Multiple requirements for sustainable buildings.

2 TECHNICAL CONTENT OF SUSTAINABLE LIFE CYCLE ENGINEERING OF MATERIALS AND STRUCTURES

2.1 Definition and factors of sustainability

Referring to Fig. 1 we could give a technical definition for sustainable building as follows (Sarja, 1997): "Sustainable building is a technology and practice, which meets the multiple requirements of the people and society on an optimal way during the life cycle of the build facility."

Much sustainability analysis and assessment work has been done during last decade. In most cases life cycle methodology has been applied. The subject is treated from the viewpoint of materials or structural components only, and important aspects of higher hierarchical levels of the build facilities. The results of comparisons regarding all types of the main sustainability requirements shown in Fig. 1, generally speaking, lead to the conclusion that differences between different materials and structural solutions of the construction phase are quite small during the construction phase. On the contrary, we can find quite large differences between existing buildings or other facilities. Those

differences are caused by differences in the basic factors of sustainability, which are the flexibility in design, the changeability during the use, the durability in comparison to the design service life and the recyclability of components due to quite short service life. In order to focus on these factors we have to take a separate look at the the different types of the building facilities.

In buildings the energy consumption is economically important and mostly dictating the environmental properties in the life cycle, the differences in environmental economy between different structural systems being otherwise quite small. For this reason, beside a well-controlled heating, ventilating and heat recovery, the thermal insulation of the envelope is important. The bearing frame is the most massive and long lasting part of the building, and the durability and flexibility in view of the functional changes, spaces and service systems are very important. The envelope shall be durable and, as mentioned above, have an effective thermal insulation and a safe static and hygrothermal behaviour. The internal walls have a more moderate length of service life, but they have a requirement of coping with relatively high degrees of change, and must therefore possess good changeability and recyclability. An additional property of an environmentally effective structural system is a good and flexible compatibility with the building service system, as the latter is the most frequently changed part of the building. In the production phase it is important to ensure the effective recycling of the production wastes in factories and on site. Finally, the requirement is to recycle the components and materials after demolition.

Engineering structures like bridges, dams, towers, cooling towers etc. often are very massive and their target service life is long. Therefore environmental efficiency is tied to selection of environmentally friendly local raw materials, high durability and easy maintainability of the structures during use, minimising and recycling of construction wastes, and finally recycling of the components and materials after demolition. Some parts of the engineering structures like water proofing membranes and railings, have a short or moderate service life and therefore the aspects of easy reassembly and recycling are most important.

All factors mentioned above are related to the properties connected to the function and performance of the building facilities. We know, that the decisive factor in our society is financial economy. The budget must always stay within the agreed limits and plays a major role when decisions between design alternatives are made.

2.2 Conclusive sustainability factors

The most important sustainability factors in performance for structures with long target service life can therefore generally be defined as flexibility towards functional changes of the facility and high durability, while in the case of the structures with moderate or short target service life changeability and recycleability are dominating. Building envelope has to have a good hygrothermal behaviour. The competitiveness in

sustainability of the comparison between materials and structures is focusing on the question, which materials and structures are able to produce, designed and manufactured with skill and at the same cost the best sustainability of the building facility.

2.3 Main trends and needs of development

The main trend in the development is the advance in small steps. This happens through technical improvements and application of the systems and methods of quality and environmental management at all phases of life cycle from design until recycling and wasting. This work is done continuously in companies assisted by researchers. It is a challenge to the research and development of materials and structural engineering to produce new knowledge, methodologies and methods to support the practical development.

Regarding materials and structures we have to develop new basic knowledge especially on hygrothermal behaviour, durability and service life of materials and structures under varying environments. That knowledge has to be put into practice through standards and practical guides. The creation of new types of materials and structures, in which the properties can be tailored separately for each specific need is of vital importance. Both strong and soft solutions are needed, depending on the specific life cycle requirements in each application. Another challenge for materials engineering is the effective recycling of building and demolition wastes. The construction area is producing about 10% of all wastes in the society. There are already good examples, how these wastes can be reused in construction. As a major consumer of materials, construction can apply many byproducts and recycling materials from industry and general consumption, but new creative innovations and applications are still needed for meeting those targets.

Regarding methods the life cycle design methodology and calculation methods connected to that are in focus. The structural design has to be capable of multiple analysis decision-making and optimising in connection with the comparison of alternatives, decision-making and optimisation of the selected structural solutions.

4 SOME MODELS FOR DEVELOPMENT OF SUSTAINABLE MATERIALS AND STRUCTURAL ENGINEERING

4.1 Modular systematics in structural engineering

In advanced building we can apply so called modular systematics. Modulation involves division of the whole into sub-entities, which to a significant extent are compatible and independent. The compatibility makes it possible to use interchangeable products and designs that can be joined together according to connection rules to form a functional

whole of the building. Typical modules are: bearing frame, facades, roofing system, partition walls and building service systems.

The modular product systematics is firmly connected to the performance systematics of the building. As an example, the main performance requirements of floors can be classified in the following way:

1. Mechanical requirements, including
 - static load bearing capacity,
 - serviceability behaviour: deflection limits, cracking limits and damping of dynamic vibrations
2. Physical requirements, including
 - air tightness
 - airborne sound insulation
 - impact sound insulation
 - moisture tightness (in wet parts of the floor)
 - thermal insulation between cold and warm spaces
 - fire resistance and fire insulation
3. Flexible compatibility with connecting structures and installations
 - partitions
 - piping,
 - wiring,
 - heating and ventilating installations

In addition to the performance requirements during service life, the entire life cycle requirements include the buildability, changeability of spaces during the use and easy demolition, reuse and wasting.

4.2 Integrated life cycle design

The overall scheme of the integrated structural design process (Fig. 2), (Sarja, 1996), includes the following main phases: Analysis of the actual requirements, interpretation of the requirements into technical performance specifications of structures, creation of alternative structural solutions, life cycle analysis and preliminary optimisation of the detailed design of the selected structural system alternatives, selection of the optimal solution between the alternatives and finally the detailed design.

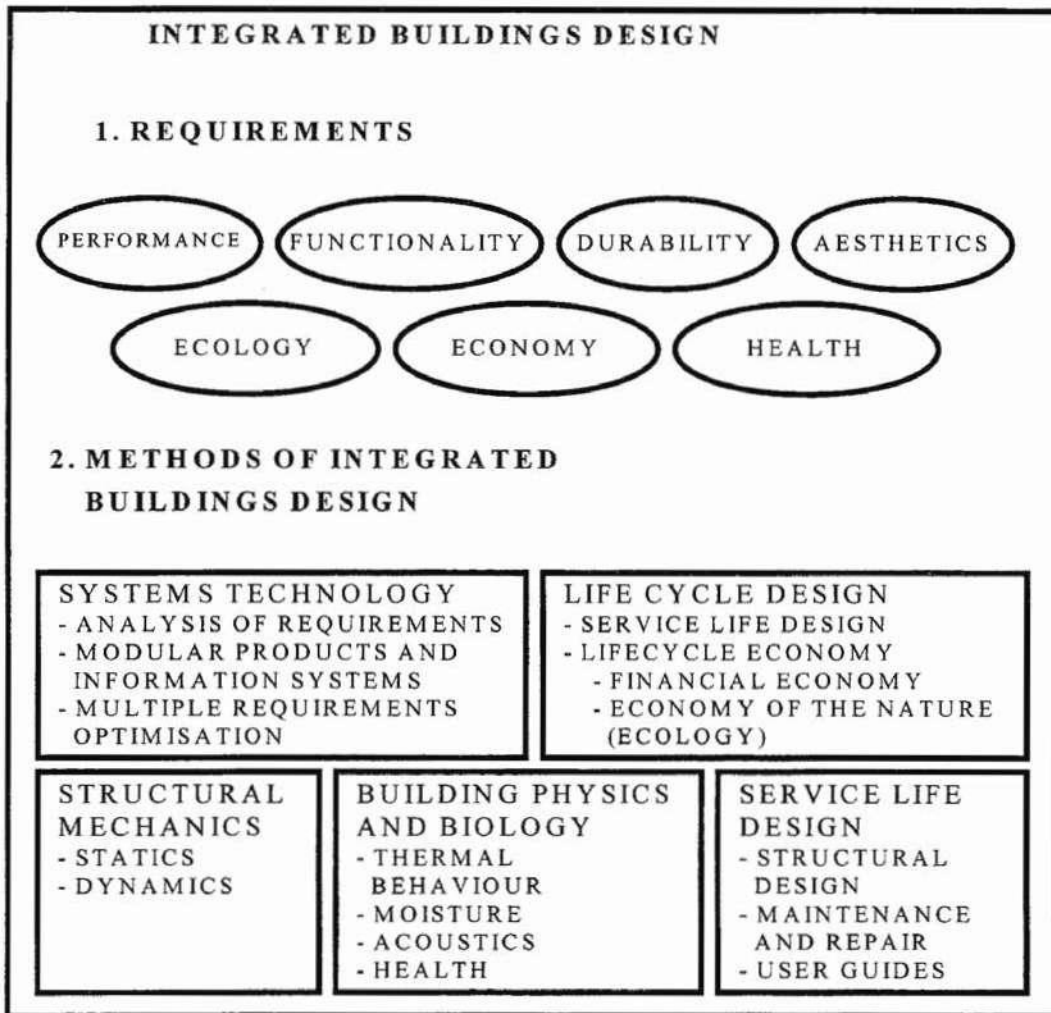

Fig. 2. Framework of the integrated structural design.

The key issues from the environmental viewpoint are the life cycle design and the service life design. With the aid of life cycle design we can optimise the monetary (financial) economy and the economy of the nature (ecology). Through the service life (performance and durability) design, the targeted service life can be guaranteed. The conceptual, creative design phase is very decisive in the utilisation of the potential benefits of the integrated design process effectively. In this phase, the design is made on the system and module level. The modular systematics help the rational design, because the structural system typically has different parts or modules with different requirements, e.g. regarding durability and service life requirements.

For the life cycle design, the analysis and design expanded into two economical levels: monetary economy and ecology, which means the economy of nature. The life cycle expenses are calculated in the present value or in yearly costs by deducting the expenses of manufacture, construction, maintenance, repair, changes, modernisation, reuse, recycling and disposal. The monetary expenses are treated as usual in current

value calculations. The expenses of nature are the use of non-renewable natural resources, the production of pollutants into air, water or soil, and the climatic global warming. These impacts dictate the environmental profiles of the structural and building service systems. The environmental impact profile generally includes the consumption of globally and locally critical raw materials like energy and water and the production of CO₂, CO, SO₂, NO_x, dust, solid wastes and noise. The aim is to limit and minimise the natural expenses below the allowed values.

It is also critical to introduce a time factor in a detailed structural design. This includes service life design to guarantee the durability and performance of the structures according to corresponding target values /4/.

Health aspects can be identified from medical knowledge and applied as criteria into structural design. These are mainly related to building physics and biology, including several hygro-thermal and acoustical methods.

The overall scheme of the integrated buildings design process (Fig. 2) includes the following main phases: Analysis of actual requirements; translation of the requirements into technical performance specifications for technical systems (structural and building service systems); creation of alternative technical solutions; life cycle analysis and preliminary optimisation of these alternative technical solutions, and selection of an optimal solution from among them; and finally the detailed design of the selected technical systems. The conceptual, creative design phase plays a decisive role in the effective exploitation of the potential benefits of the integrated design. At that stage, the design works on a system level. Modular systematics greatly help rational design, because the technical systems typically comprise different parts, here called modules, each with different requirements as to e.g. durability and service life.

In the integrated structural design several methods and technical skills are needed. The safety and mechanical serviceability is guaranteed through the traditional mechanical design with the methods of statics and dynamics. The controlled technical serviceability through the target service life is guaranteed by the durability design. Health is protected by the methods of building physics including hygro-thermal physical and chemical methods. The selection of final solutions between alternative structural ideas, materials and products can be done applying the methods of multiple requirements decision-making.

The sustainability can be concretised in the design applying the life cycle design methodology, in which case parallel economical and ecological analysis and optimisation are carried out. In this methodology the ecology is interpreted as the economy of the nature. The ecological expenses are calculated for each component of the so called environmental profile of the construction. The environmental impact profile generally includes the consumption of globally and locally critical raw materials like energy and water and the production of pollutants into air, soil and

waters, generally including CO₂, CO, SO₂, NO_x, dust and solid wastes. The goal is to limit the natural expenses below the allowed values and to minimise the natural expenses.

Currently, the monetary economy and the natural economy may be in contradiction with each other, e.g. because of the pricing and the different taxes between work and resources. These cases then lead to valuation problems, which must be decided by the clients using their defined valuation in the framework of a society's norms. In addition to the calculated expenses, there are also factors which can not be numerically determined. Such factors are e.g. the impact of construction into the biodiversity and the production of noise, which have to be evaluated and valued separately by society's general rules for individual design cases.

4.3 Recycling building technology

The ecological aspects include the quantitative goals regarding the consumption of non-renewable natural resources, the production of pollutants into air, soil and water and the qualitative goals regarding non-calculative effects like biodiversity and noise. In cold conditions, the availability of local materials and energy are decisive. As an example, wood is often available as a renewable material from sustainable forestry. Other typically locally available materials are gravel, cements and natural stones. The consumption of these materials shall also be planned on a sustainable way avoiding the deterioration of the environment. The consumption of building materials can be considerably limited with effective recycling and use of byproducts like blast furnace slag, fly ash and recycled concrete. The most potential local energy is bioenergy, especially wood. The energy wood production can be combined to a large extent with sustainable forestry using the wastes of forest care and harvesting for energy production. This kind of collection and distribution activity should be systematically planned and organized to form a special effective business area. Another potential renewable energy source even in cold areas is solar energy. Its application however causes several difficulties due to the need of large and effective storage from sunny summer time to the main consumption period in the winter. This annual storage is possible e.g. with hydrogen storage, but this technology is still too expensive for general application. The main function of solar energy in cold areas therefore is heating warm tap water especially in summer time.

The scheduling of the building concept is started by the specification of the energy economy and other economical and ecological life cycle specifications of the buildings. This scheduling produces the optimised technical performance specifications. The procedure of this analysis and optimisation follows the general procedure and methods of the integrated design, which was presented before.

One important aspect is the combination of the low-energy building concept with the application of bioenergy in heating. This combination considerably strengthens the economical and ecological sustainability of both these components.

Modular systematics is preferred in the product system. This allows the systematic allocation and optimisation of the target service life as well as the life cycle economy and the ecology of the different parts of the building. A suited modularization at the highest level of hierarchy is the following: bearing frame, envelope, foundations, partitions, heating and ventilating services, information, water and sewage system, control services and waste management system. All of these assemblies are specified during the development or design process with continuously increasing precision starting from general performance specifications and ending in detailed designs.

The components of the environmental profile of the basic materials already include the recycling efficiency, which means the environmental expenses in recycling. It is important to realise that the recycling possibilities of the building components, modules and even technical systems shall be reconsidered in connection with design. The higher the hierarchical level of recycling, the higher also the ecological and economical efficiency of recycling. Typical examples of the rough estimates of the recycling efficiency are the following:

1. Recycling of materials:
 - consumption of raw materials 0.5 - 0.9
 - consumption of energy 0.0 - 0.5
 - production of pollutants 0.1 - 0.7
2. Recycling of structural or installation components:
 - consumption of raw materials 0.7 - 0.9
 - consumption of energy 0.7 - 0.9
 - production of pollutants 0.8 - 0.9

4.4 Information systems and networking

Information systems and networking are an important tool in the development of economical construction, which serves the possibility for economically competitive sustainable building. The competitiveness can be achieved through the international combination of knowledge, special strengths and technologies of research and practice in different countries.

The modern information system is based on the rapid communication network between the partners of the building projects. The communication is increasingly integrated into the computers thus integrating the design and production planning and control into the communication between partners and general databases. This helps to avoid the difficulty caused by long distances, which is a typical feature at the cold climate countries. Internet is helping in international communication thus increasing the

EFFECT OF CURING TEMPERATURE AND SILICA FUME ON THE PORE STRUCTURE OF HARDENED CEMENT PASTE



Erik J Sellevold
Ph.D. Professor
NTNU, TRONDHEIM



Christine J Hauck
Dr Ing, Control Engineer
Norwegian Public Roads Adm
BUSKERUD

ABSTRACT

Low Temperature Calorimetry has been used to characterize the pore structure of mature hardened cement paste with w/b-ratio of 0.40 containing 0,5 and 10 % silica Fume, cured at 20, 45 and 70°C. The results show clearly that increased curing temperatures lead to a coarser and more continuous pore structure in the reference. Pastes with silica fume have finer and less continuous pore structures, and are less sensitive to elevated curing temperatures.

Key words: Cement Paste, silica fume, curing temperature, pore structure.

1 INTRODUCTION AND SCOPE

Curing concrete at elevated temperatures is well known to reduce the quality of the hardened concrete both in terms of strength and durability properties. Today, with increasing use of cement replacement materials it is of interest to ascertain the effects of curing temperature on concretes with different binder compositions. The present work focuses on the effect of silica fume on the pore structure of cement paste cured at 20, 45 and 70°C. Low temperature calorimetry to measure ice formation in water saturated samples has been used to characterize the pore structure. The main advantage of this method is that it is not necessary to dry the sample strongly (105°C) before the test, as is the case for other commonly used methods such as Mercury Intrusion Porosimetry and Nitrogen Sorption. Strong drying is known to alter the pore structure

of cement paste dramatically as well as to introduce cracks. The use of Low Temperature Calorimetry as a pore structure probe is well documented (1,2,3,4), as is the effect of drying on pore structure (2,5). The work reported here is a supplementary part of a Dr Ing Thesis (6), concerning chloride migration in concrete.

2 EXPERIMENTAL

Cement pastes with water-to-binder ratio of 0.40 containing 0, 5 and 10 % silica fume (SF) by weight of total binder were mixed and poured into sealed plastic bottles. Mighty 150 was used. The bottles were rotated until setting had occurred, and then heated at 10°C/hr to the appropriate curing temperature. After 3 days the samples were cooled to 20°C, and kept there at least 6 months before testing. This regime was chosen to simulate realistic conditions. After this sealed curing, the specimens were dried at 50°C and saturated with water before testing in the calorimeter. Full saturation is of course a precondition to obtain a meaningful characterization of the pore structure in terms of ice formation.

The Calorimeter tests were run from room temperature to - 60°C at a rate of 3.3°C/ hr, followed by heating at 4.1°C / hr. Heat flow is recorded continuously during a run, and the results presented as graphs of apparent heat capacity (Cal/deg/g) vs temperature. In such a presentation the area under a curve represents total heat flow in a chosen temperature range, and the area above a base line the heat associated with ice formation/melting. Thus, knowing the heat of fusion, the amount of heat may be converted to amount of ice frozen or melted in the temperature range. The test procedure and theory is documented (1). Detail of materials characteristics and procedures are given in (6). Note that the basis for interpreting ice formation data in terms of pore structure is capillary theory which relates freezing point depression in pore water to pore size; the smaller the pore size, the lower the freezing point (2).

3 RESULTS AND DISCUSSION

Fig 1 shows the calorimeter results during cooling and Fig 2 during heating. The corresponding calculated amounts of total ice formation during heating and cooling are given in Table 1, as well as the amount of ice formed to - 20°C during cooling. The latter amount is of particular interest in connection with frost resistance - and represents the larger capillary pores that are continuous (larger diameter than about 6 nm (2)). Note the very large hysteresis between COOL and HEAT curves; the ice that forms at very low temperatures during cooling melts at temperatures nearer 0°C. Table 1 shows good agreement between the total amounts formed during COOL and HEAT. We believe cooling is a continuous process where the ice formation proceeds through the pore system, rather than nucleating individually in each pore. In this view, ice formation is controlled by the continuity of the pore system, while the size of the individual pores control the melting point (1). Such hystereses is common in cement

paste, f. inst. adsorption desorption and intrusion - extrusion of mercury, and is ascribed to ink-bottle pores.

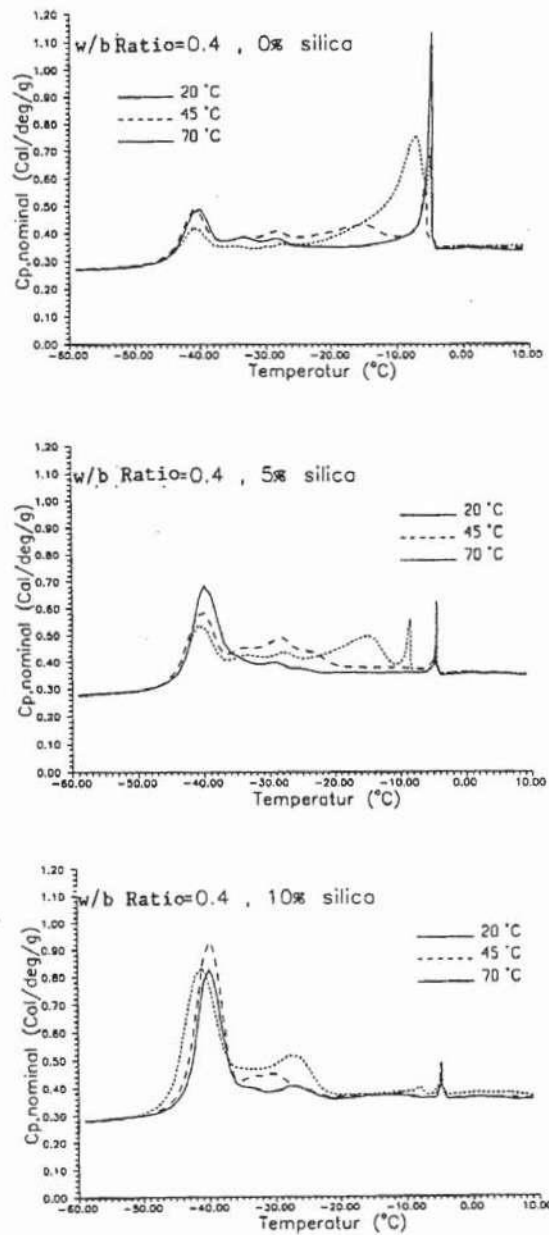

Fig 1

Effect of curing temperature on cement paste porosity containing different amount of SF (cooling cycle, ice formation)

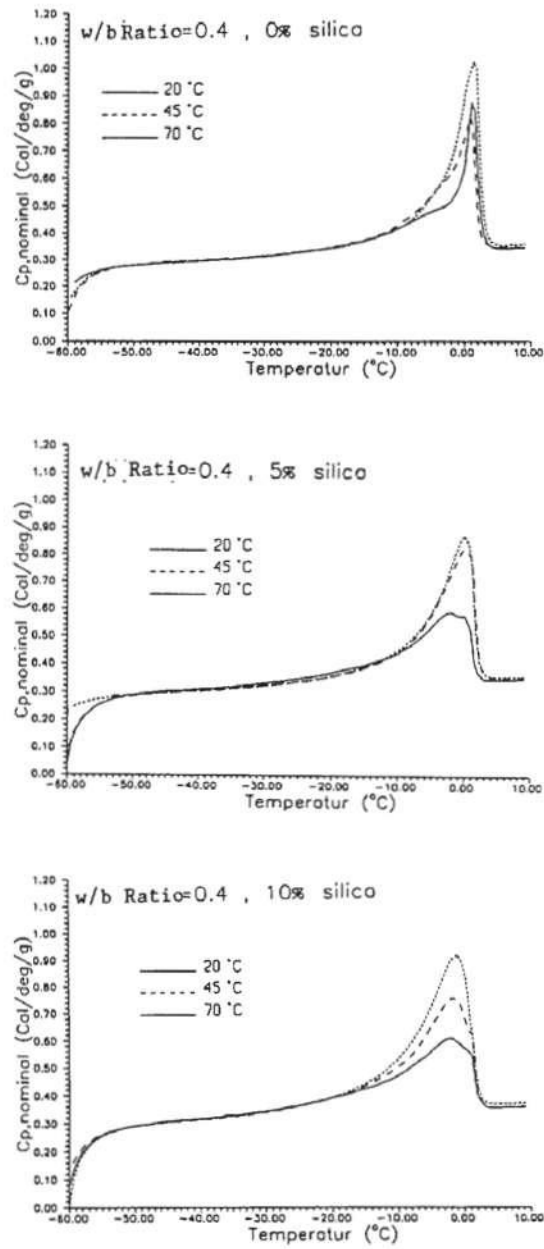

Fig 2

Effect of curing temperature on cement paste porosity containing different amount of SF.(heating cycle, ice melting)

Cement Paste	Cooling (to -20°C)		Cooling (to -60°C)	Heating (> -40°C)	
	Amount of ice g/g SSD	amount of ice (% of evaporable water)	Total ice g/g SSD	Total ice g/g SSD	Total ice (% of evaporable water)
0 % SF -20°C	0,0162	9,2	0,050	0,063	35
0 % SF -45°C	0,0176	9,7	0,057	0,069	38
0 % SF -70°C	0,0397	23	0,066	0,076	45
5 % SF -20°C	0,0066	3,5	0,059	0,062	32
5 % SF -45°C	0,0089	4,5	0,070	0,075	38
5 % SF -70°C	0,0204	11	0,070	0,079	41
10 % SF -20°C	0,0077	3,8	0,072	0,069	34
10 % SF -45°C	0,0077	3,6	0,089	0,081	37
10 % SF -70°C	0,0063	2,9	0,100	0,098	45

Table 1 Amounts of ice formation during COOL and HEAT

Table 1 shows that there is an increase in total ice with increasing SF-dosage at all curing temperatures. This is in line with the fact that the total porosity to water also increases with SF-dosage on a 1:1 replacement of cement basis (3). However, the pore structure becomes more refined and with less continuity with increasing SF-dosage, as is evident from Fig 1 and Table 1. Much less ice forms to -20°C, and further more the amount is much less sensitive to curing temperature than the paste without SF. The increase in total ice formation in the SF-pastes takes place around -40°C as is clearly seen in Fig 1. Such a low freezing point is evidence of very small connecting channels between larger pores, as indicated by the higher melting temperatures (Fig 2). Note also that for all 9 pastes less than 50 % of the total evaporable water is freezable at all to -60°C (Table 1). Thus, most of the pore water, and more with increasing SF-dosage, is so strongly influenced by interfacial forces that it is not frozen at -20°C. This effect of SF on the pore system is also evident with respect to chloride migration in concrete, which is strongly reduced with increasing SF-dosage and the effect of increased curing temperature is less severe (6). This indicates that the very fine pores do not contribute substantially to the transport process.

One further point is worth notice; the pastes in these experiments were all predried at 50°C before resaturation and testing. This process by itself leads to a more coarse and continuous pore structure (5), but not to cracking. Thus, in a not-predried state all the pastes would show much less ice formation as demonstrated previously (1,5).

4 CONCLUSIONS

In cement paste with a constant water-to-binder ratio increased silica fume dosage leads to increases porosity to water, but to a more refined and less continuous pore structure.

The detrimental effect of a more coarse pore structure with increasing curing temperature is reduced with increasing silica fume dosage.

The practical consequences are reduced rates of chloride migration, and less freezable water in the relevant range for frost resistance, to - 20°C.

5 REFERENCES

- 1 DeFontenay, O S and Sellevold, Erik J: "Ice Formation in Hardened Cement Paste -I. Mature Water Saturated Pastes", Durability of Building Materials and a Components, ASTM STP 691, American Society of Testing Materials, 1980. Presented Ottawa Conference Aug 1978.
- 2 Sellevold, Erik J and Bager D H: "Low Temperature Calorimetry as a Pore Structure Probe", Proceeding of the 7th International Congress on the Chemistry of Cements, Vol IV, Paris, July 1980.
- 3 Sellevold, Erik J, Bager, D H, Klitgaard Jensen, K and Knudsen, T: "Silica Fume Cement Pastes: Hydration and Pore Structure", Nordisk Seminar 1982, Report BML 82.610, Norges Tekniske Høgskole, Feb 1982, pp 19 - 50.
- 4 Sellevold, Erik J and Jacobsen S: "Frost/Salt Scaling and Iceformation in Concrete: Effect of Curing Temperature and Silica Fume". International Workshop on the Resistance of Concrete to Scaling due to Freezing in the Prescence of Deicing Salts, Quebec 30-31 August 1993. RILEM PROCEEDINGS NO. 30, 1997.
- 5 Bager, D H and Sellevold Erik J: "Ice Formation in Hardened Cement Paste II - Drying and Resaturation on Room Temperature Cured Pastes", Cement and Concrete Research, Vol 16, 1986, pp 835 - 844.
- 6 Christine J Hauck: Thesis: The Effect of Curing Temperature and Silica Fume on Chloride Migration and Pore Structure of High Strength Concrete. Trondheim, NTH 1993.

MATERIAL TECHNOLOGY – A KEY TO IMPROVED PRODUCTIVITY



Åke Skarendahl
 PhD, Director
 Swedish Cement and Concrete
 Research Institute
 100 44 STOCKHOLM
 SWEDEN

ABSTRACT

Development of materials is a versatile tool in the improvement of production techniques. Material research and development thus have an impact on productivity, i.e. reducing cost and increasing speed. This is exemplified with the development of self compacting concrete and fibre concrete.

Key words: Productivity, Material technology, Production methods, Self compacting concrete, Fibre concrete

1 REDUCED COST, FASTER BUILDING PROCESS

Improvement of production technologies, enhancement of quality assurance in the production process and improvement of the working environment are all vital components in the strive to reduce the cost of concrete construction. Increasing the speed of production results in shortening of the lead times which in itself is an important tool for increased competitiveness. Reducing cost and increasing speed, i.e. increased productivity, is thus a necessary target for research and development on concrete construction.

Material technology naturally plays an important role in reducing building costs, and material technology is a versatile tool in increasing the speed of production. There are several examples where development of material technology has had important impact on the production technique, leading to increased productivity. In the present paper this will be exemplified by the development of highly workable concrete leading to more efficient casting and compaction, and the development of fibre reinforcement reducing time and cost for reinforcement work.

2. SELF COMPACTING CONCRETE

Distribution of concrete in formwork as well as compaction of fresh concrete, are process steps requiring substantial manpower as well as machinery. A concrete able to flow over long distances without segregation and a concrete which can consolidate itself with no external energy input will of course make increased productivity in concrete construction possible. Based on knowledge of rheology of particle suspensions, such concrete materials are now under rapid development, Okamura (1997), Skarendahl and Petersson (1997). These so called self compaction concretes allow shortening of the production process.

2.1 Rheology

Fresh concrete can be described as a particle suspension, although rather complex. A concrete suspension can be defined on different size levels, e.g. coarse aggregates in a liquid phase consisting of water, cement and fine particles (mortar), or sand particles in a liquid phase consisting of water and cement grains (paste). As in all suspensions, the balance between flowability and segregation is vital. Many of the key parameters can be described in rheological terms, represented as in FIG 1.

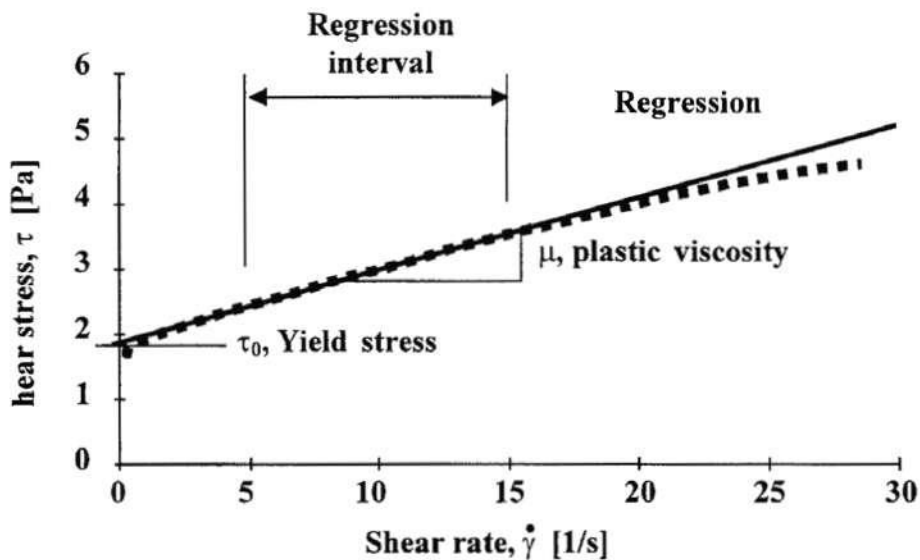

FIG 1. Rheological evaluation of shear stress and shear rate gives yield stress (at rate = 0) and plastic viscosity (inclination of curve), Billberg (1997).

Following the Bingham model, a low yield stress value strongly influences the flow value and the plastic viscosity is important for the time of flow. The rheological behaviour is also central when describing a non-segregating suspension. The amount of moveable water has to be limited to avoid bleeding, and the liquid phase have to be so composed as to give the suspension an adequate plastic viscosity behaviour to avoid segregation.

The rheological behaviour measured on fine mortar, which here is defined as including all particles below 0,25 mm, can be shown to have a decisive impact on the rheology of a concrete made with that fine mortar. The fine mortar properties also strongly influence many concrete workability parameters. Optimising fine mortar rheology through modifying the size, geometry and content of the fine particles as well as considering the influence of the cement and the admixtures, thus are central tools in creating a self compacting concrete.

2.2 Self compacting concrete

Based on improved knowledge of factors influencing the fine mortar rheology, it is possible to create a concrete that can fill formwork and consolidate itself without any added external energy input. In addition, the concrete has to be able to flow through narrow openings, e g between the reinforcing bars. To achieve this behaviour the following three characteristics have to be met:

- appropriate flowability
- homogeneity (non-segregating)
- no blocking tendency (passing through openings between rebars etc)

The blocking criteria will very much determine the size and shape of the coarse aggregate, as well as the volume of the liquid phase. Based on an optimised fine mortar rheology, coarser aggregate is added. An important factor for the evaluation of the risk of blocking is the reinforcement arrangement in the structure to be cast.

The mix design process can thus, according to Petersson et al (1996), be devised into the following steps:

1. Identification of criteria set for the material (strength, strength gain, durability, openings between bars, flowability, loss in flowability etc). The criteria is given by the client following the type of structure to be built and the production method chosen.
2. Determination of the fine mortar volume. (Fine mortar includes liquids and all particles less than 0,25 mm). The fine mortar volume is obtained through an evaluation of the void content of the combination of aggregate

fractions intended for use, and from an evaluation of the blocking criteria following models given in e.g. Van (1994).

3. Formulation of the fine mortar considering cement type, wc-ratio, type and amount of super plasticizers, fillers (mineralogy, particle shape and sizes, amount) and viscosity agents. The target properties are related to rheological data, at this stage of development mainly related to experience. The data are obtained through the use of a fine mortar viscometer.
4. Formulation of the concrete, i e after adding aggregate to the fine mortar. This step is carried out through practical and field applicable testing of properties of interest for the final concrete mix, i e flow, loss of flowability, homogeneity, blocking strength. The use of a concrete viscometer improves the possibilities of a successful final formulation of the concrete.

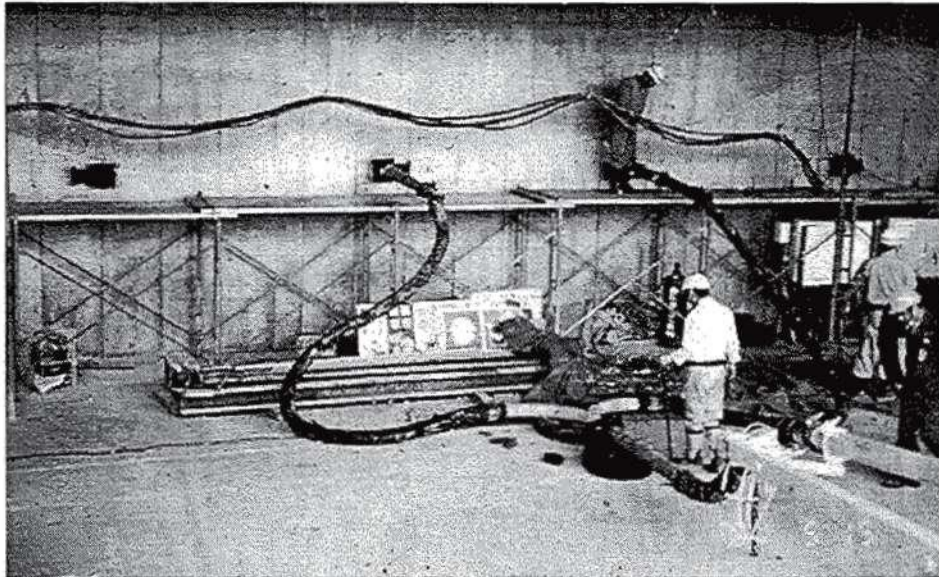

FIG 2. Form filling of self compacting concrete through pump pressure from bottom of the formwork, Hayakawa (1996).

2.3 Applications

The development of self compacting concrete has been particularly strong in Japan. Following research work in Tokyo University, the technology spread to Japanese contractors and a number of applications have been carried out. One interesting example is the casting of the highest concrete building structure in Japan. Parts of the structure were cast through pumping concrete through valves in the bottom of the formwork, Hayakawa (1996), see FIG 2. Filling heights of 40 m at a time were applied.

An application where the construction time was in focus was the anchors of the Akashi bridge. More than 400 000 m³ of self compacting concrete was cast using an automated pumping procedure. The maximum aggregate size used was 40 mm and the concrete was dropped 3 meters, however still meeting the segregation criteria, Okamura (1997), see FIG 3.

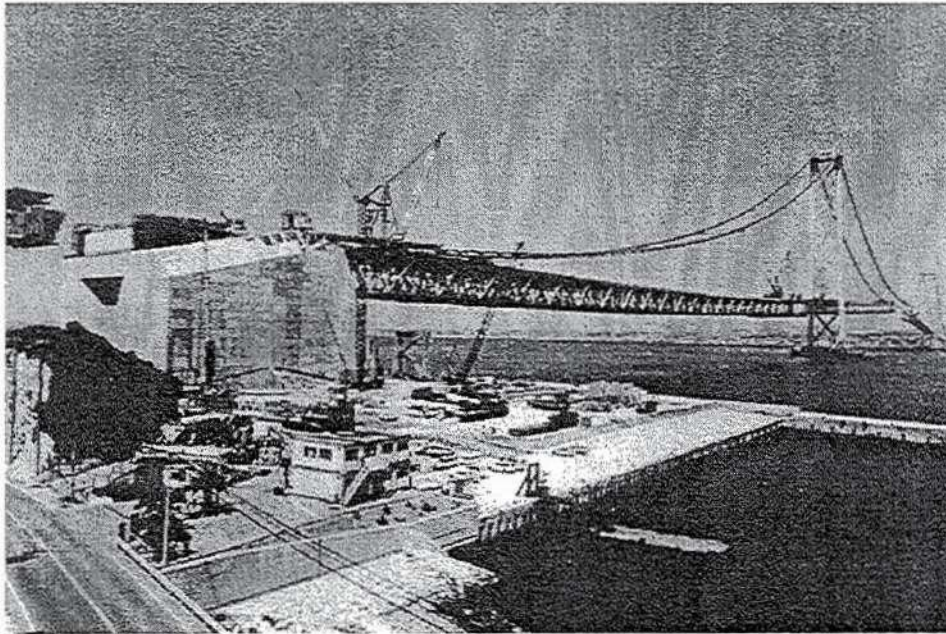

FIG 3. The construction time for the anchors of the Akashi bridge was reduced from 2,5 to 2 years through the use of self compacting concrete. Okamura (1997).

Pilot testing in full scale of self compacting concrete has taken place in Sweden both with houses and civil engineering structures in mind. The first full scale applications on bridge projects have recently started, see FIG 4.

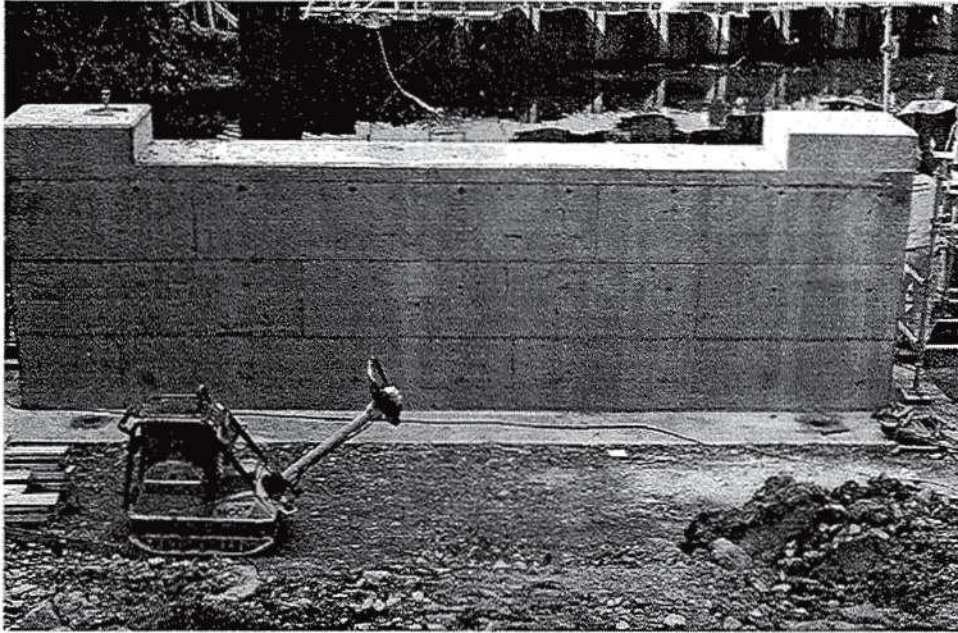

FIG 4. Full scale application of self compacting concrete in a bridge support.

3. FIBRE CONCRETE

Placing of reinforcement is a time consuming process. If bar or mesh reinforcement can be avoided, positive effects are obtained not only in reducing the time for the reinforcement placing but also for the whole production process. If for instance a slab on ground is cast without traditional reinforcement, the concrete trucks can deliver the concrete directly at the casting place and not via a pump which otherwise would add to the cost and the time of production.

To be able to eliminate – or reduce – traditional reinforcement, the concrete has to have an inherent toughness and a capacity of crack control. This has been shown possible through the inclusion of fibres. Fibres enhance the mechanical performance of concrete and allow alternative designs giving opportunities for increased performance and lower cost. An equally important effect of fibre inclusion is however the possibilities of obtaining a rational production procedure. The production technology related improvements are also to date the strongest reason the use of fibre concrete in practice.

3.1 Toughness and crack control

One deficiency of concrete is the fact that the shrinkage surpasses the deformation capacity. The consequence is obviously that concrete cracks if the component in question is restrained, and so are concrete components in most cases. The normal solution is the use of shrinkage reinforcement giving the composite component an ability to withstand increased deformation without losing the load bearing capacity. This is not achieved through completely hindering the cracking, but a crack distribution and thus a crack width control is achieved. A material with inherent toughness and an appropriate crack control would eliminate the need of using shrinkage reinforcement. Also in the case of other forced deformations, as well as in many other situations, a concrete with an inherent toughness and a good crack control is desired.

Replacing traditional reinforcement and brittle concrete with a material having an ability of maintaining a load bearing capacity over large deformations, and a control over crack development, open new possibilities. The production process can be radically changed as an effect of such a material technology development.

3.2 Fibre concrete

Inclusion of tough fibres in the brittle concrete has shown to give a material with considerable energy absorption capacity. The stress transfer between a fibre and its surrounding concrete matrix carry tensile stresses after cracking of the matrix. The balance between bond leading to pullout on one hand and fibre fracture on the other, then decides the fracture process. Efficient hindering of crack growth at the tip of a critical crack leads to an increased energy consumption in the fracture process either caused by the surpassing of bond/fibre fracture, or by the opening of additional cracks.

The mechanism has been shown to be efficient in many practical situations, among them in the case of restrained shrinkage. The effect can be tested in small scale through the casting of a circular specimen around a stiff core, e.g. a steel ring, see Grzybowski (1989). The observation typically made is that even small inclusions of fibres radically reduces the crack width, see FIG 5, which indicates the possibility to achieve a good effect already with small fibre volumes. The effect can be used in the construction of slabs on grade.

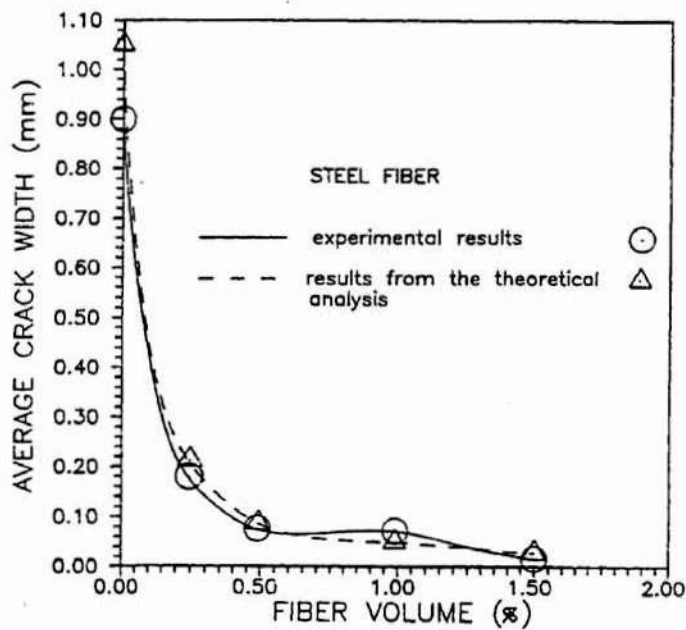

FIG 5. Average crack width versus steel fibre volume in a ring restrained shrinkage concrete test. Grzybowski (1989).

In some applications, e.g. rock strengthening, the requirement is focused on a specified load bearing capacity after a certain deformation. Traditionally this requirement has been obtained by using mesh and bar reinforcement and sprayed concrete. A similar technique is used in repair work. The installation of the reinforcement is cumbersome and time consuming especially as the surface on which the reinforcement is to be attached to normally is very irregular, see FIG 6. The irregularity also tends to cause large thicknesses of the strengthening layer. The spraying of concrete on meshes or bars is difficult and sometimes leaves cavities at the reinforcement surface opposite the main spraying direction reducing bond and inducing a risk of reduced durability.

Steel fibre reinforced sprayed concrete has shown to be a versatile production method, Skarendahl (1995). It has also been shown to give sufficient toughness for many rock strengthening applications, see FIG 7.



FIG 6. Fibre concrete sprayed on a an irregular rock surface allows thinner layers to be applied compared with what would have been possible with a traditional mesh reinforced sprayed concrete. (Photo: Stabilator).

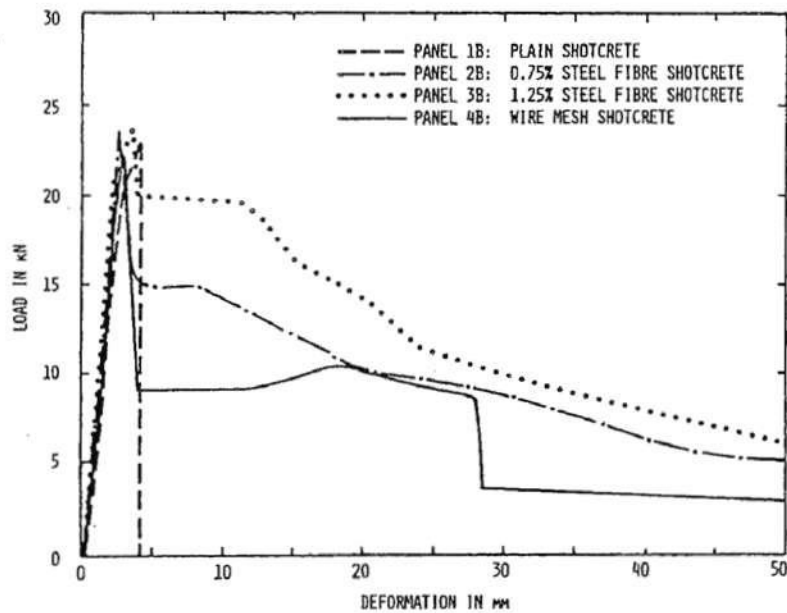

FIG 7. Comparison of load bearing capacity of plain, mesh reinforced and steel fibre reinforced fibre concrete, Morgan and Mowat (1984).

3.3 Applications

Fibre concrete is now an established technique in areas where there is an evident gain in productivity. In the area of rock strengthening the fibre sprayed concrete technique has in Sweden had a very strong impact with an almost complete replacement of the mesh reinforcement with steel fibres. This development has been jointly driven by clients and contractors.

The use of fibres for replacement of shrinkage reinforcement has been implemented mainly in the field of industrial floors. Here the development in Sweden is still rather limited and not in pace with the expanding development in other countries. The restraining factor seems to be the lack of initiatives from the structural designers to implement the achievements of new material and production technologies into their specifications.

Fibre concrete can replace conventional mesh reinforcement in floors with maintained thicknesses and distances between joints. With increased dosage and increased fibre efficiency, the fibre concrete solution gives also possibilities of alternative designs. A 20 000 m² steel fibre concrete industrial floor was placed in Örebro, Sweden five years ago with distances between joints of 22 meters instead of the original design of 6 meters, Nordin (1997), see FIG 8. The use of fibre concrete and the increased joint spacing led to a drastically increased productivity. The man-hour time per square meter was reduced to less than half compared with the normal practice. Inspection after 5 years of service shows excellent service conditions.



FIG 8. Producing an industrial floor in steel fibre concrete allows elimination of reinforcement placing, direct delivery from the truck and wider joint spacings.

Development of steel fibre production and casting techniques have increased productivity to such a degree that a floor surface of 12 000 m² can be produced in one day, Destrée (1994). In addition the joint spacing is increased and, with high fibre efficiency, reaching the level where jointless floors are made. A lot of examples of advanced fibre concrete industrial floors can be seen in many countries.

Application of steel fibre sprayed concrete is dominating in normal Swedish rock conditions. When good bond between the sprayed concrete and the rock can be expected, unreinforced sprayed concrete is often used. Due to the great variation in bond, many clients decide to use fibre reinforcement also in those conditions. In parts where good bond can not be anticipated, fibre sprayed



FIG 9. Robotized spraying of fibre shotcrete. (Photo: BESAB)

concrete is used in combination with bolting. In very bad rock conditions, the use of traditional bar or mesh reinforcement is still applied, either in sprayed form as arches or as a separate structure in the form of a lining. The latter area only accounts for a few percent of the total rock strengthening surface. Thus steel fibre sprayed concrete is an established technology in the Swedish practice, see FIG 9, as it is in other countries with similar rock conditions.

4. CONCLUSIONS

Material development and production technology is strongly interconnected. This is also the case for concrete construction. In the effort of increasing the productivity, the cost as well as the lead times have to be reduced. Material development for improved production processes thus is a versatile tool for improved competitiveness, which is proved by the development and use of self compacting concrete and fibre concrete.

5. REFERENCES

Billberg P (1997). CBI-material to be published.

Destrée X (1994). Béton armé de fibres d'acier. Applications aux dallages industriel Silifiber. Annales de l'Institut Technique du Batiment et des Travaux Publics, Paris, No 522, 1994, pp 112-119.

Grzybowski M, (1989). Determination of crack arresting properties of fiber reinforced cementitious composites. Publ. Trita-Bro-8908, Dept of Structural Engineering KTH, Stockholm, 190 pages.

Morgan D R and Mowat D N (1984). A comparative evaluation of plain, mesh and steel fiber reinforced concrete. American Concrete Institute SP-81, Detroit, pp.307-324.

Nordin A (1997). Private communication.

Okamura H (1997). Self-compacting high-performance concrete. Concrete International, Vol 19 Number 7, p.p. 50-54.

Petersson Ö, Billberg P and Van B K (1996), A model for self compacting concrete. Proc. from International RILEM Conference on Production Methods and Workability of Concrete, Paisley, Ed by P.J.M. Bartos, E&FN Spon, London, pp.483-492.

Skarendahl Å (1995). Development and use of steel fibre shotcrete. Proc. From A RILEM Workshop on Concrete technology – new trends, industrial application, Barcelona, Ed by A Aguado, R Gettu and S P Shah, E&FN Spon, London, pp. 257-272.

Skarendahl Å and Petersson Ö (1997). Self compacting concrete. Proc. Of a RILEM-WTA Seminar on High performance concrete, Zurich, Ed by F H Wittmann, AedificatioVerlag, Stuttgart, pp. 101-116.

Van B K (1994). A method for the optimum proportioning of the aggregate phase of highly durable vibrations-free concrete, A Master thesis submitted to Asian Institute of Technology, Bangkok.

CONTROL OF CRACKING IN CONCRETE STRUCTURES DUE TO IMPOSED STRAIN



Sven Thelandersson
Professor
Structural Engineering
Lund University

ABSTRACT

Cracking in concrete structures due to imposed strain is investigated. The effect of uniform and non-uniform imposed strain is studied for medium-thick walls with respect to the amount of reinforcement necessary to distribute cracks. The effect of reinforcement on the behaviour after the first crack, in particular its ability to reduce crack widths, is investigated. The restraint force, determining the amount of crack reinforcement, is significantly reduced for non-uniformly distributed imposed strain due to softening and cracking in the concrete. Crack reinforcement is not effective for structures with small dimensions in the direction of external restraint. The amount of reinforcement needed to distribute cracks is significantly smaller for imposed strain in the form of drying shrinkage than for thermally induced strain.

Keywords: minimum reinforcement, imposed strain, restraint

1 INTRODUCTION

Concrete structures for civil engineering construction are usually designed with significant reinforcement to control cracking due to imposed strains. The amount of reinforcement necessary for crack control depends on three factors:

- the magnitude and spatial distribution of imposed strains,
- the degree of restraint of the structure
- the deformation capacity of the concrete

Especially the first two factors are difficult to estimate and in practical design it is usually assumed on the safe side that the imposed strains are large and that the restraint is almost complete without further analysis. The consequence of such an overestimation in massive structures is a large amount of reinforcement making the casting process difficult and counteracting durability performance.

Presently used design rules of the minimum reinforcement are based on the principle that the stress in the reinforcement at cracking should not exceed yield, i.e. the yield capacity of the reinforcement should be higher than the force necessary to create a new crack [1]. In this way the reinforcement redistributes the stresses after the appearance of the first crack so that several narrower cracks arise instead of a few wide-opened [2]. It is important to point out that the reinforcement can not prevent the onset of cracking. Its main function is to distribute cracks and limit crack widths once cracks are created. Furthermore, even for fully restrained structures, crack reinforcement is only needed when the imposed strain is larger than the strain capacity of the material. If the restraint is limited, as is usual in practice, the imposed strain can be further increased before cracking takes place and the reinforcement starts acting effectively.

Analyses of simple structural elements subjected to imposed strain was made by Nagy [3]. The forces actually arising in a reinforced wall due to non-uniformly distributed imposed strain, taking into account softening and cracking, were studied. It was found that due to the successive growth of cracking through the section the force needed to create a crack is only about half of the maximum force corresponding to the nominal tensile stress capacity of the cross section. The spatial distribution of imposed strain developed from sudden cooling is roughly equivalent with the imposed strain from drying shrinkage [5], i.e. the results and conclusions regarding sudden cooling can also be applied for drying shrinkage. The effect of reinforcement on post cracking behaviour and crack widths were also studied.

Important contributions in the field of cracking in concrete due to imposed strain have been made by Falkner [6] and Helmus [7]. According to Falkner practically no cracks are created due to internal restraint for medium thick walls exposed to atmospheric conditions.

In this paper the following issues will be adressed:

- Under what conditions is crack reinforcement necessary?
- The function of crack reinforcement after cracking due to imposed strain.
- The amount of reinforcement needed for crack control.

2. REFERENCE STRUCTURE

A medium-thick wall, characterised by the geometry shown in Fig.1, is used as a reference structure. The external restraint acting on the wall is modelled with a set of springs characterised by the spring coefficient k (N/m^2) related to the spring force P_z (N/m). Results obtained from analyses of this structure will be

used to draw more general conclusions about reinforcement in concrete structures for control of cracking due to imposed strain.

Cooling is modelled either as a linear thermal diffusion process, one dimensional and symmetric with respect to the mid plane of the wall or as uniform cooling over the wall thickness. It is assumed that cooling can also represent imposed strain from drying shrinkage. The wall is assumed to be in a state of generalised plane strain in the y and z directions.

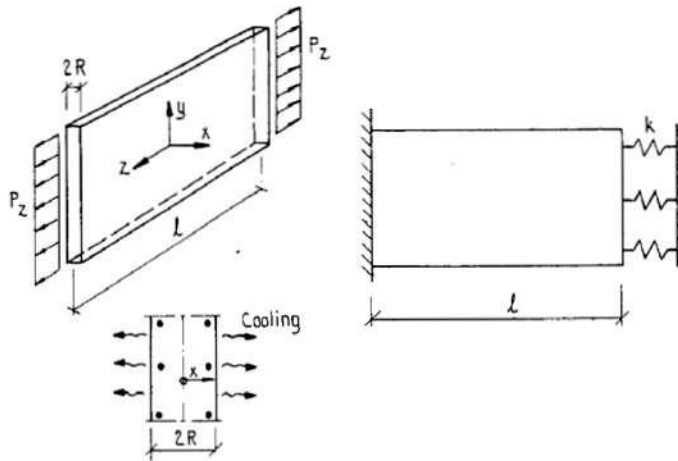

Fig.1 Geometry of medium-thick wall.

The overall equilibrium in the z direction gives

$$\int_0^R \sigma_z dx + \sigma_{zs} \cdot A_s = \frac{P_z}{2} \quad (1)$$

where σ_z is the stress in the concrete, σ_{zs} is the stress in the steel, A_s is the reinforcement area/unit length at each surface of the wall and P_z is restraint force/unit length. The concrete is modelled in different ways depending on the type of analysis employed. When tension softening is considered the stress-strain relation in tension is of the simple form shown in Fig. 2. The steel is assumed to be linearly elastic in all cases considered in this paper.

The maximum possible force in the section, P_z^{lim} , corresponds to the case when the tensile strength of the concrete is reached simultaneously over the whole section. The following relation is valid for P_z^{lim} :

$$\frac{P_z^{\text{lim}}}{2} = Rf_{ct} + E_s A_s \epsilon_{sT \text{ tot}} \quad (2)$$

where $2R$ is the thickness of the wall, f_{ct} is the tensile strength of the concrete, E_s is the Young's modulus of the steel, A_s is the amount of reinforcement, $\epsilon_{sT \text{ tot}}$ is the total imposed thermal strain in the steel.

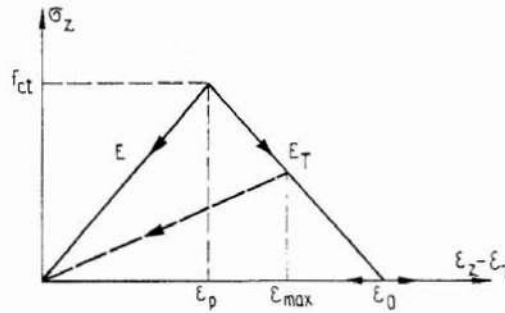

Fig.2 Assumed bilinear stress-strain relation for concrete in tension.

3. CHARACTERISATION OF IMPOSED STRAIN

Imposed strain occurring in practice can be of many different forms. It was suggested in [4] that a reasonable simplification can be to idealise imposed strain as two distinct types of processes, one where the imposed strain is *uniform* over the cross section and one where it is highly *non-uniform* corresponding to a step change at the surface.

Non-uniformly distributed imposed strain corresponding to sudden cooling is typical for extreme situations with very rapid changes in temperature which may occur occasionally. It is reasonable to assume that a practical maximum of such temperature changes is of the order 20 °C. The case of sudden cooling is also representative for imposed strain related to drying shrinkage in indoor climate [5], where the total drying shrinkage may be about $5 \cdot 10^{-4}$ (drying from 100% to 50% relative humidity), corresponding to an equivalent sudden temperature drop of about 50 °C. The drying shrinkage can be calculated with the formula proposed by Hillerborg [8] $3.75 \cdot (w_0 - 50) \cdot 10^{-3}$, where w_0 is the original water content (kg/m^3) of the concrete mix. Drying shrinkage for outdoor climate is about 60% of that for indoor climate. For high strength concrete the gradient for drying shrinkage is less due to self-dessication.

Structures exposed to outdoor climate are subjected to temperature changes corresponding to yearly variation in temperature at the geographical location in question. The magnitude of yearly temperature changes can be of the order 50 °C in temperate and cold climates. However, the most interesting temperature drop is that from the highest average temperature after casting. The yearly temperature variation can be assumed to give *uniform temperature distribution* over the cross section. Minor disturbances from daily temperature changes may be superimposed, but these are normally only affecting the outermost concrete layers in structures of larger dimensions.

Imposed strains give rise to stresses in a structure if they are not free to develop. Such restraint can be classified as external or internal. *External restraint*

corresponds to forces from adjacent structures, supports and foundations restraining the element from movement. *Internal restraint* is associated with imposed differential strain within a structural element, such that different portions of a structural element restrain each other. The different types of imposed strain described above are related to external and internal restraint according to Table 1.

Type of imposed strain	Type of restraint
Uniform	External
Non-uniform	Internal or combined internal/external

Table 1. Classification of restraint and imposed strain

4. CRITICAL MAGNITUDE OF IMPOSED STRAIN

If the stress-related strain in the concrete is smaller than the strain capacity of the concrete, no cracks will occur and crack reinforcement is not needed. A simple analysis of the critical magnitude of the imposed strain for the reference structure in Fig. 1 is easily made, assuming that the imposed strain is uniform over the wall thickness and that a through crack is formed when the strain exceeds ϵ_p . The coefficient of thermal contraction of the concrete α_c is taken to 10^{-5} K^{-1} . The critical temperature change can then be calculated as a function of the restraint stiffness k . The result is shown in Fig. 3 where the restraint stiffness is given in dimensionless form related to the axial wall stiffness $2ER/L$. For uniformly distributed imposed strain corresponding to a temperature change of 50°C the relative restraint must be less than 0.2 to 0.6 (depending on the strain capacity of the material) to avoid cracking. This means that the restraint - if it can be described as an elastic spring- must be less than the axial stiffness, if cracks due to imposed strain shall be avoided for structures exposed to outdoor climate.

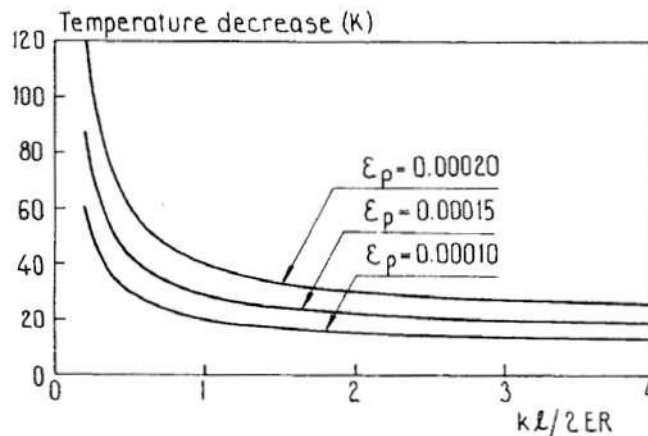

Fig 3 Critical temperature decrease as a function of relative restraint stiffness.

5 INFLUENCE OF DISTRIBUTION OF IMPOSED STRAIN

In [3] and [9] the reference structure in Fig. 1 was analysed for different degrees of restraint and for different cooling processes taking into account successive softening and cracking through the cross section. The assumed stress-strain relation for concrete in tension is shown in Fig. 2. One of the results from these simulations is the development of restraint force during the process and in particular the maximum force P_{zmax} obtained. This force may be compared with the maximum possible force P_{zlim} given by Eq. (2).

Fig. 4 shows the relative force P_{zmax}/P_{zlim} developed in an almost fully restrained wall as a function of the strain ratio $\epsilon_{Ttot}/\epsilon_p$, where ϵ_{Ttot} is the imposed thermal strain and ϵ_p is the strain capacity of the material. The relative maximum force created in the wall is more or less independent of wall thickness. When the imposed thermal strain is higher than the ultimate tensile strain ϵ_0 a through crack is developed. With the chosen value of $E_T/E = -1.55$, this occurs for values of $\epsilon_{Ttot}/\epsilon_p$ higher than 1.65, c.f. Fig. 2.

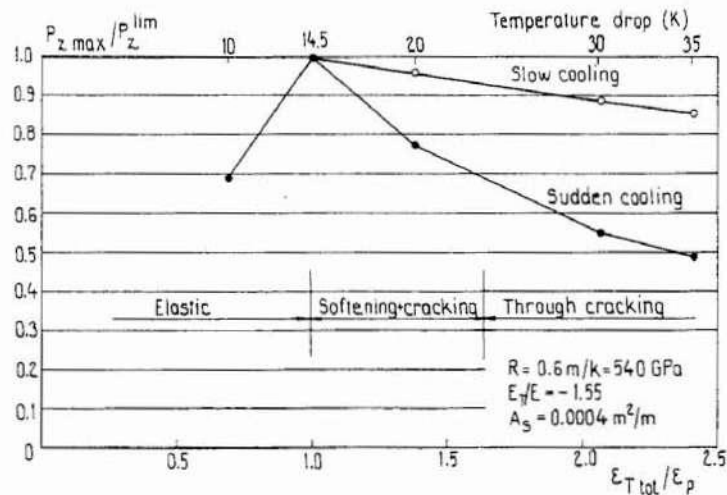

Fig. 4 Force developed in fully restrained wall as a result of cooling.

Further results of this type are presented in [9] showing that for cases with slow cooling, the maximum restraint force developed in processes leading to through cracking is higher than for cases with rapid cooling (or drying shrinkage). In the latter case the force actually arising when a through crack develops is only about 0.5-0.7 of the maximum possible force P_{zlim} , which leads to a considerable reduction of the amount of reinforcement needed. This is valid both for strong and weak external restraint, and irrespective of the value of the softening modulus E_T [9]. The reason for this reduced restraint force is the successive growth of softening and cracking through the section created by the non-uniform distribution of imposed strain in this case. Consequently, from the

point of view of required minimum reinforcement a non-uniform distribution of imposed strain is advantageous.

6 INFLUENCE OF SOFTENING MODULUS E_T

In Fig. 2 the softening behaviour of concrete in tension is described in a simplified manner by using a bilinear stress strain relation with a constant softening modulus E_T . In reality the softening is localised to a very narrow zone, in which the behaviour can be described by fracture mechanics models such as the fictitious crack model [10, 11]. The effective softening modulus depends on the fracture energy G_f and the elastic modulus E of the concrete as well as on the length ℓ of the structural element. Under certain simplifying assumptions the effective softening modulus can be calculated from the expression [10,11]

$$E_T = \frac{E}{1 - \ell_{ch}/\ell} \quad (3)$$

where ℓ_{ch} is a characteristic length which can be regarded as a material property, and is related to the fracture energy G_F according to the formula $\ell_{ch} = G_F E / f_t^2$ where f_t is the tensile strength of the concrete. The value of ℓ_{ch} is of the order 300 to 400 mm for ordinary concrete [11], which means that $|E_T|$ becomes very large if ℓ is of the order 0.6 m or larger, i.e. brittle, unstable fracture can be expected to occur in full size structures.

For a plain concrete wall (corresponding to the reference structure in Fig 1) with fully developed external restraint, the length ℓ is the actual length of the wall. For a wall with reinforcement the effective length determining the softening modulus E_T (or the brittleness) is less than the actual length of the wall, since some of the strain energy in the wall is transferred to the reinforcement when the crack is formed. In other situations the concept of a constant softening modulus defined by Eq. (3) gives only an approximate description of the actual behaviour, but some qualitative conclusions can still be made. For cases with internal restraint, i.e. with non-uniform distribution of imposed strain, the strain gradient over the thickness has only the potential to create surface cracks with limited length. The length determining the brittleness (the zone where the stress will be released when a crack is formed) is in this case of the same order of magnitude as the length of the crack, [5], i.e. the material behaviour will be more ductile, and the critical magnitude of the stress-related strain when an open crack is formed can be larger than ϵ_p . If the external restraint is limited, crack reinforcement will usually not be needed for internal restraint, since the distribution of cracks will take place anyway. When a surface crack is created, a small zone in the concrete near the crack is unloaded, but further away along the length other cracks will be formed since the internal restraint will not be

released here. The presence of reinforcement will however have a certain effect to reduce the crack width.

7 INFLUENCE OF REINFORCEMENT

Reinforcement can not prevent cracking, but when cracking has occurred it will have the effect to reduce the crack width compared to the case without reinforcement. If the reference wall in Fig. 1 is exposed to *uniformly distributed imposed strain* large enough to create a through crack, see Fig. 3, the fracture process will normally be brittle, so that the crack is created when the strain in the concrete attains the value ϵ_p defined in Fig. 2. If no reinforcement is present in the wall, the crack width immediately after cracking is determined by the condition that complete unloading takes place in the whole wall. Thus, for a fully restrained plain concrete wall, the crack width immediately after cracking (before further imposed strain is developed) will be $w_{\max} = \epsilon_p \ell$, i.e. all the strain in the concrete immediately before cracking is localised to the crack. If the wall is provided with longitudinal reinforcement (defined by the reinforcement ratio ρ) the wall will only be partially unloaded when the first crack appears. Some of the restraint force will be carried by the reinforcement crossing the crack.

To evaluate the influence of reinforcement on the behaviour of the wall after cracking the following assumptions are made:

1. The wall is fully restrained so that the total length change for steel Δs as well as the total length change for concrete Δc are both zero.
2. The steel force in the cracked section is transferred to the concrete over a length a with uniformly distributed bond. Then, the longitudinal variation of stress $\sigma_s(x)$ in the reinforcement and the stress $\sigma_c(x)$ in the concrete will be as shown in Fig. 5. The concrete stress $\sigma_c(x)$ should be interpreted as the average stress over the cross section x .
3. Outside the zone with length $2a$ adjacent to the crack, full composite action is assumed between steel and concrete.
4. Elastic behaviour is assumed in the steel along the whole length and in the concrete outside the cracked section.

Assumptions 1 and 4 give the following two kinematical relations

$$\Delta s = \int_0^{\ell} \frac{\sigma_s(x)}{E_s} dx + \epsilon_{Ts} \cdot \ell = 0 \quad (4)$$

$$\Delta c = \int_0^{\ell} \frac{\sigma_c(x)}{E_c} dx + \epsilon_{Tc} \cdot \ell + w = 0 \quad (5)$$

where E is Young's modulus, ϵ_T is imposed strain and w is the crack width. The indices s and c refer to steel and concrete respectively.

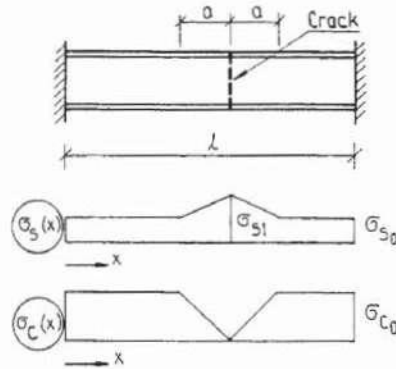

Fig 5. Stress in concrete and reinforcement at first crack

Assumption 3 with notations defined in Fig. 5 gives

$$\frac{\sigma_{so}}{E_s} + \varepsilon_{Ts} = \frac{\sigma_{co}}{E_c} + \varepsilon_{Tc} \quad (6)$$

Finally, the following equilibrium relation is valid, see Fig. 5.

$$P_z = \sigma_{s1} \cdot A_s = \sigma_{so} \cdot A_s + \sigma_{co} \cdot A_c \quad (7)$$

where P_z is the external restraint force and other notations are defined in Fig. 5.

Eqs. (4-7) can be solved for the basic unknowns σ_{co} , σ_{so} , σ_{s1} and w . For the special case with thermally induced strain it is assumed that $\varepsilon_{Ts} = \varepsilon_{Tc}$, i.e. the coefficient of thermal contraction is the same for steel and concrete. Then, the following solutions are obtained

$$\sigma_{co} = (-E_c \varepsilon_{Tc}) \frac{\rho \alpha}{\rho \alpha + \frac{a}{l}} \quad (8)$$

$$\sigma_{s1} = (-E_s \varepsilon_{Ts}) \frac{1 + \rho \alpha}{\rho \alpha + \frac{a}{l}} \quad (9a)$$

$$w = (-\varepsilon_{Tc} \cdot l) \frac{(1 + \rho \alpha) \frac{a}{l}}{\rho \alpha + \frac{a}{l}} \quad (10)$$

Here, $\rho = A_s/A_c$ is the reinforcement ratio and $\alpha = E_s/E_c$. Fig. 6 shows the ratio w/w_{max} as a function of the reinforcement parameter $\rho \alpha$, for different values of a/l . The maximum possible crack width $w_{max} = -\varepsilon_{Tc} \cdot l$ is the crack width obtained without reinforcement.

If the imposed strain originates from drying shrinkage in the concrete we have $\epsilon_{Ts} = 0$ and $\epsilon_{Tc} < 0$. Eq. (8) for concrete stress and Eq. (10) for crack width are the same for this case but the expression for steel stress is modified to

$$\sigma_{s1} = (-E_s \epsilon_{Tc}) \frac{1 - \frac{a}{\ell}}{\rho\alpha + \frac{a}{\ell}} \quad (9b)$$

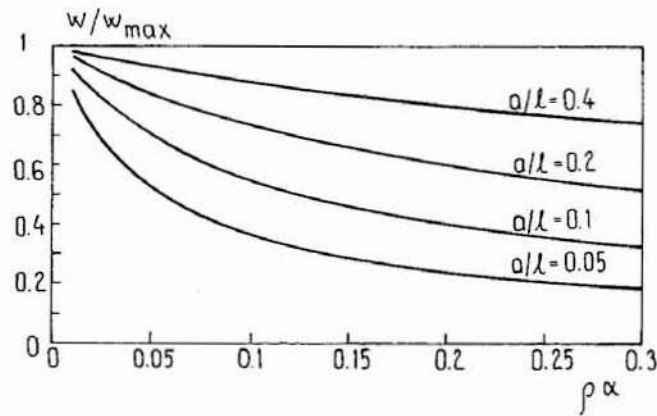

Fig.6 Influence of reinforcement on the crack width. Fully restrained case.

$$w_{max} = -\epsilon_{Tc} \ell = \text{crack width without reinforcement}$$

For concrete structures where the design of crack reinforcement is made according to current practice the parameter $\rho\alpha$ is in the range 0.05-0.10. This amount of reinforcement is quite effective to limit the crack width for low values of a/ℓ , e.g. for long walls. On the other hand the maximum crack width w_{max} in such structures are also large. As an example, for a given transfer length a and with $\rho\alpha=0.1$ the crack width will increase with 33 % when the length ℓ is doubled (so that a/ℓ is changed from 0.1 to 0.05). Note that also smaller amounts of reinforcement may reduce the crack width to some extent compared with the situation in plain concrete, provided that the steel does not yield immediately when the crack is formed.

If the imposed strain ϵ_{Tc} is further increased after the first crack has been formed, the steel stress σ_{s1} in the cracked cross section, the concrete stress σ_{c0} and the crack width w are gradually increased. In this case one of two things may happen:

1) A second crack may be formed in the wall. This happens when σ_{c0} becomes equal to the tensile strength f_{ct} of the concrete, or from Eq. (8) when

$$\frac{-\varepsilon_{Tc}}{\varepsilon_p} = 1 + \frac{a/\ell}{\rho\alpha} \quad (11)$$

where $\varepsilon_p = f_{ct}/E$ is the strain capacity of the concrete.

2) The steel stress may reach the yield limit f_{st} . This happens when $\sigma_{st} = f_{st}$, or from Eq. (9a) when

$$\frac{-\varepsilon_{Ts}}{\varepsilon_p} = \frac{-\varepsilon_{Tc}}{\varepsilon_p} = \frac{f_{st}}{E_s \varepsilon_p} \cdot \frac{(\rho\alpha + \frac{a}{\ell})}{(1 + \rho\alpha)} \quad (\varepsilon_{Ts} = \varepsilon_{Tc}) \quad (12a)$$

which is valid when $\varepsilon_{Ts} = \varepsilon_{Tc}$. For the case $\varepsilon_{Ts} = 0$ the following relation is obtained from Eq. (9b)

$$\frac{-\varepsilon_{Tc}}{\varepsilon_p} = \frac{f_{st}}{E_s \varepsilon_p} \cdot \frac{(\rho\alpha + \frac{a}{\ell})}{(1 - \frac{a}{\ell})} \quad (\varepsilon_{Ts} = 0) \quad (12b)$$

The three limits given by Eqs. (11) and (12) are shown in Fig. 7 as a function of $\rho\alpha$ for $a/\ell = 0.1$. The dimensionless ratio $f_{st}/E_s \varepsilon_p$ is in Fig. 7 set to 17.0, a typical value for ordinary reinforcing steel and concrete with normal deformation capacity.

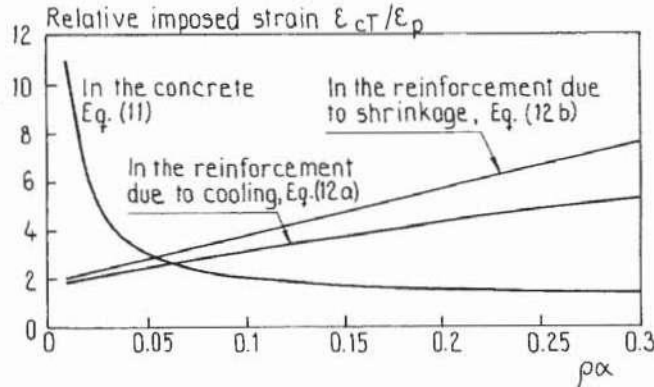

Fig 7. Relative imposed strain $\varepsilon_{Tc}/\varepsilon_p$ which will create a second crack or yield in the reinforcement as a function of $\rho\alpha$, for $a/\ell = 0.1$. $f_{st}/E_s \varepsilon_p = 17$.

The limits are equal for the "balanced" reinforcement ratio

$$(\rho\alpha)_{bal} = \frac{1}{\frac{f_{st}}{E_s \varepsilon_p} - 1} \quad \text{if } \varepsilon_{Ts} = \varepsilon_{Tc} \quad (13a)$$

$$(\rho\alpha)_{bal} = \frac{E_s \varepsilon_p}{f_{st}} (1 - \frac{a}{\ell}) \quad \text{if } \varepsilon_{Ts} = 0 \quad (13b)$$

The balanced ratio can be seen as the minimum reinforcement required to create a second crack before yield in the steel. This ratio is displayed as a function of a/ℓ in Fig. 8. For thermally induced strain the balanced reinforcement ratio is independent of a/ℓ , whereas for shrinkage this ratio decreases with a/ℓ . The reinforcement required for shrinkage is less than for thermal imposed strain, especially for large values of a/ℓ .

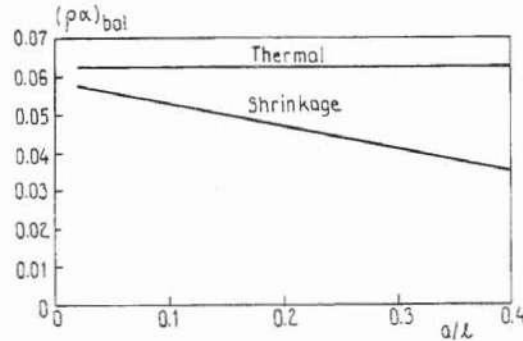

Fig 8. Minimum reinforcement ratio to create a second crack for shrinkage and thermal imposed strain. $f_{st}/E_s\varepsilon_p = 17$.

The maximum value of $|\varepsilon_{Tc}|$ before yield or further cracking occurs if the reinforcement is equal to $(\rho\alpha)_{bal}$, see Fig. 7. Combination of Eqs. (10) and (13) gives

$$\frac{-\varepsilon_{Tc}}{\varepsilon_p} = 1 + \frac{a}{\ell} \left(\frac{f_{st}}{E_s\varepsilon_p} - 1 \right) \quad \text{if } \varepsilon_{Ts} = \varepsilon_{Tc} \quad (14a)$$

$$\frac{-\varepsilon_{Tc}}{\varepsilon_p} = 1 + \frac{\frac{a}{\ell}}{(1 - \frac{a}{\ell})} \cdot \frac{f_{st}}{E_s\varepsilon_p} \quad \text{if } \varepsilon_{Ts} = 0 \quad (14b)$$

Assuming balanced reinforcement, see Eq. (13), the maximum possible imposed strain before yield or further cracking is displayed in Fig. 9.

The corresponding crack width (for the first crack) for balanced reinforcement is obtained by inserting Eqs. (13) and (14) into Eq. (10). This gives

$$\frac{w}{\varepsilon_p \ell} = \frac{f_{st}}{E_s\varepsilon_p} \cdot \frac{a}{\ell} \quad \text{if } \varepsilon_{Ts} = \varepsilon_{Tc} \quad (15a)$$

$$\frac{w}{\varepsilon_p \ell} = \frac{f_{st}}{E_s\varepsilon_p} \cdot \frac{a}{\ell} \left(\frac{1}{1 - a/\ell} + \frac{1}{f_{st}/E_s\varepsilon_p} \right) \quad \text{if } \varepsilon_{Ts} = 0 \quad (15b)$$

The relative crack width is shown in Fig. 10 as a function of a/ℓ .

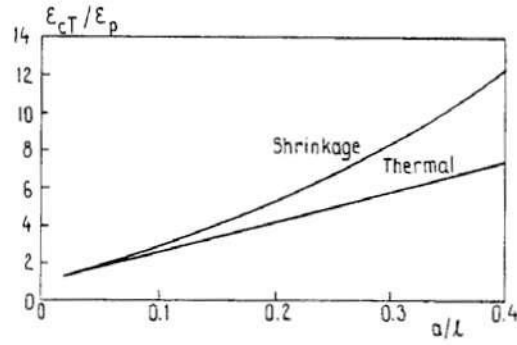

Fig. 9 Maximum possible value of $|\epsilon_{cT}/\epsilon_p|$ as a function of a/l . Balanced reinforcement with $f_s/E_s\epsilon_p = 17$.

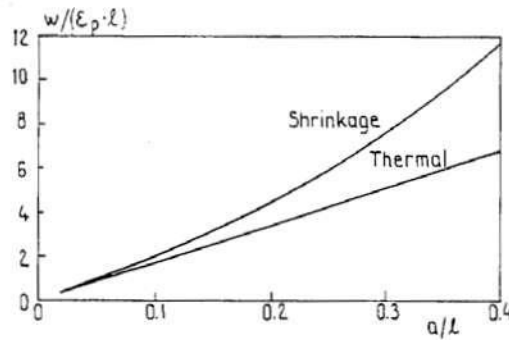

Fig. 10 Relative crack width $w/(\epsilon_p \ell)$ for balanced reinforcement.

The maximum possible imposed strain before a second crack is created as well as the relative crack width increase with a/l . Since the balanced reinforcement for shrinkage is smaller, the crack width in this case is larger and the maximum possible shrinkage is somewhat smaller than for thermal strain. For small values of a/l , i.e. long walls, the imposed strain when the second crack is formed is only about twice the value ϵ_p it had when the first crack was formed, whereas for large values of a/l (shorter walls) the second crack is formed only after the imposed strain becomes many times larger than ϵ_p . The relative crack width also increases with a/l , but the absolute crack width mainly depends on a , and is almost independent of ℓ . The conclusion is that for short walls (or corresponding situations such as internal restraint) the reinforcement is neither needed nor effective to limit crack widths.

8 SUMMARY AND CONCLUSIONS

The minimum reinforcement needed to control cracking due to imposed strain in concrete structures depends on the magnitude and distribution of imposed strain, the degree of restraint and the deformation capacity of the material. In the present paper these factors have been analysed for a simple reference structure in the form of a wall with axial restraint.

For the purpose of discussion, imposed strain may be idealised as two distinctly different cases, one where the imposed strain is *uniform* over the cross section and one where it is highly *non-uniform* with strong gradients.

Uniformly distributed imposed strain

This case is mainly relevant for thermal action. The following conclusions apply for this case:

1. Even for full restraint, concrete can normally survive an imposed strain of 0.1-0.15 ‰ corresponding to a temperature change of 10-15 °C without cracking.
2. If the external restraint stiffness is less than half of the axial stiffness of the structure, the imposed strain can be significantly larger without risk for cracking.
3. Reinforcement has negligible effect to prevent cracks being formed, but it will have a certain effect to reduce the crack width once a crack has been created.
4. The reinforcement is more effective to reduce crack widths for long structures with external restraint.
5. For very short lengths the effect of crack reinforcement to reduce crack widths is very limited.

Non-uniformly distributed imposed strain

This case is valid for extreme situations with rapid changes in temperature as well as for imposed strain related to drying shrinkage in indoor climate. Non-uniformly distributed strain will give rise to internal restraint, i.e. different parts of the cross section restrain each other even if there is no external restraint. The following conclusions can be made from the present study:

1. The maximum restraint force created by a non-uniformly distributed imposed strain is only about 50-60 % of the nominal tension capacity of the structure. The reason for this is the successive growth of softening and cracking created by the non-uniform distribution of imposed strain. The conclusion is valid regardless of the degree of external restraint.
2. This advantageous effect may be taken into account for imposed strain in the form of drying shrinkage in indoors climate or by formworks removal at low temperature, but can normally not be utilised for structures where the imposed strain originates from temperature variations in outdoor climate.
3. For cases with internal restraint but with limited degree of external restraint, reinforcement for crack control is not needed, since the distribution of cracks will take place anyway and usually no trough cracks will be formed. In such cases, the ability of reinforcement to reduce crack widths is also very limited.
4. The amount of reinforcement needed to distribute cracks in structures with strong external restraint is significantly smaller for drying shrinkage than for

thermal strain. The reason for this is that the steel stress is lower and the imposed strain is normally non-uniform, which reduces the restraint.

In summary, there are many cases where crack reinforcement may be omitted or limited:

- Structures with small dimensions (a few meters) in the direction of external restraint.
- Structures where the external restraint is small compared with the axial stiffness of the structure itself
- Structures where internal restraint is dominating and where external restraint is limited
- Cases where the magnitude of imposed strains is only of the same order of magnitude as the strain capacity of the concrete.

However, reinforcement to control cracking due to imposed strain should be provided for structures with large dimensions in the direction of restraint. In this case the amount of reinforcement should be large enough to create new cracks in the structure without reaching the yield limit. The amount of reinforcement may be reduced to about half, if the imposed strain originates from drying shrinkage.

ACKNOWLEDGEMENTS

This work was financially supported by Elforsk AB- the Swedish Electrical Utilities Research and Development Company.

REFERENCES

- [1] CEB, "Design Manual on Cracking and Deformations", No 158, 1985.
- [2] Jaccoud J. P., "Armature minimale pour le contrôle de la fissuration des structures en béton", École Polytechnique Fédérale de Lausanne, Thèse No 666, 1987.
- [3] Nagy A., "Thermally Induced Softening and Cracking in Concrete with Minimal Reinforcement", *Materials and Structures* (1997), **30**, pp 527-532.
- [4] Thelandersson S., Alemo J., Nagy A., "Cracking of Concrete Structures Due to Imposed Strains with Regard to Design of Reinforcement." *Materials & Structures* (1997). In press.
- [5] Thelandersson S., Mårtensson A., Dahlblom O., "Tension Softening and Cracking in Drying Concrete", *Materials and Structures*, (1988), **21**, pp 416-424.
- [6] Falkner H., "Zur Frage der Rissbildung durch Eigen- und Zwängsspannungen infolge Temperatur in Stahlbetonbauteilen." *Deutscher Ausschuss für Stahlbeton*, Heft 208, Berlin 1969.
- [7] Helmus M., "Mindestbewehrung swangbeanspruchter dicker Stahlbetonbauteile." *Deutscher Ausschuss für Stahlbeton*, Heft 412, Berlin 1990.
- [8] Hillerborg A., "Kompendium i byggnadsmateriallära, FKI" Div. of Building Materials, Lund University, Sweden, 1975.
- [9] Nagy A., "Cracking in Reinforced Concrete Structures Due to Imposed Deformations. Dissertation, Report TVBK-1012, Div. of Struct. Eng., Lund University, Lund, Sweden, 1997.
- [10] Hillerborg A., "A Model for Fracture Analysis," Report TVBM-3005, Div. of Build. Mat., Lund Institute of Technology, Sweden, 1978.
- [11] Gustafsson P.J., "Fracture Mechanics Studies of Non-Yielding Materials Like Concrete: Modelling of Tensile Fracture and Applied Strength Analysis", Report TVBM-1007, Div. of Build. Mat., Lund Institute of Technology, Sweden, 1985.

ASSESSMENT OF SERVICE LIFE FOR CONCRETE STRUCTURES

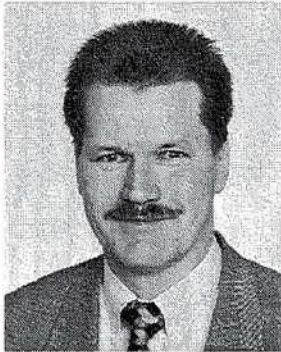

Kyösti Tuutti
PhD. visiting Professor Lund University
Skanska Teknik AB

ABSTRACT. The service life of concrete due to reinforcement corrosion have been discussed intensively the past twenty years. Initiation of the process of corrosion by carbonation is relatively predictable today by the use of simple diffusion theories. The other main initiation mechanism, chloride ion penetration, is more difficult to predict. The main problem is the lack of quantitative figures on threshold values for corrosion initiation. Our investigations indicate that there is not a fixed threshold value. The limit chloride concentration will vary due to the electrochemical inhomogeneity around the steel surface. Although it is possible to make lifetime calculations if we compare our practical experience with corrosion theories. This report will more precisely discuss the most important parameters with the aim to find a comparison method for different concrete mixes.

Keywords: Chloride, diffusion, threshold values, corrosion, PFA, silica fume, OPC, lifetime, predictions.

1 INTRODUCTION

The simplified model of the process of corrosion demonstrated in figure 1, indicate the two general mechanisms behind the initiation of the reinforcement corrosion. Carbonation, where the airborne carbondioxide is reacting with the pH buffering chemicals is normally the initiating mechanism in relatively dry environments or in high permeable concretes. The front of carbonation is also distinct and will move into concrete with a rate depending on different diffusion processes. In wet or chloride rich environments the carbonation process is relatively slow by the clogging effect of water. The chloride induced corrosion problem is much more complicated as we are no longer dealing with a clearly separated front which penetrates the material. If the surrounding environment contain chloride with a greater concentration than the pore solution in the concrete pores the chloride concentration will increase gradually.

The corrosion process is initiated first when a certain chloride concentration has been reached around the steel. This concentration is called the threshold value.

On the other hand the threshold value is not a precise limit value, which have confused the research people around this theme. The reported values which could be acceptable varies from 0.1 % Cl by weight of the cement content to several percentages. The main parameter influencing on the threshold value is the chemical composition and chemical micro

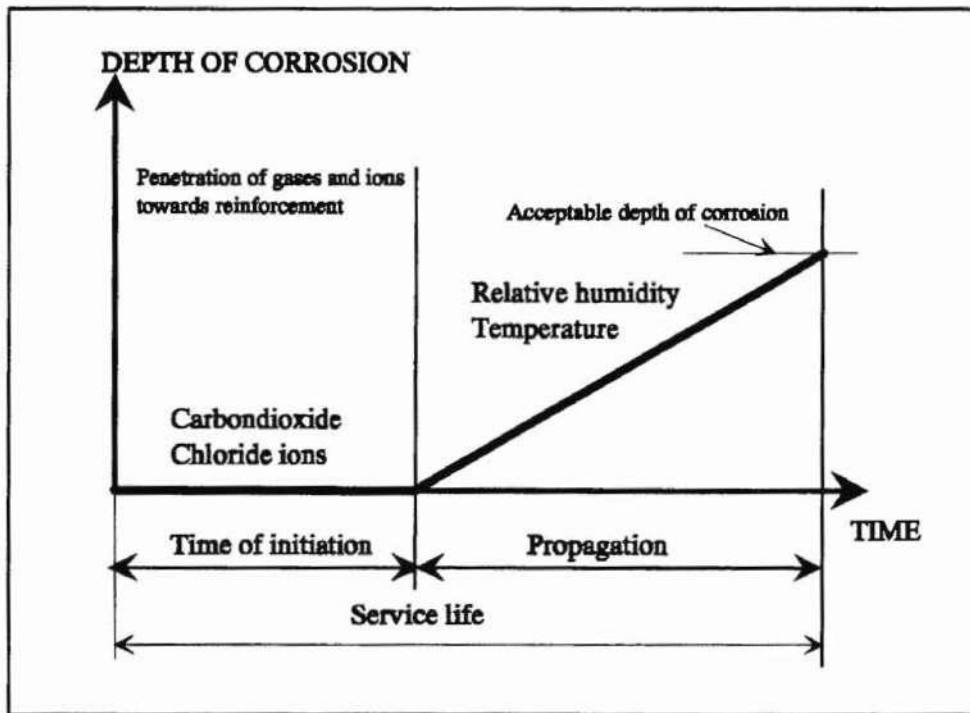

Figure 1. Schematic sketch of steel corrosion sequence in concrete, Tuutti /1977/.

variations close to the steel surface. Such chemical compositions and variations depends of the type of binder used in the concrete and physical differences in the concrete.

Theoretical calculations and modelling of the time of initiation in a chloride rich environment demonstrate the lack of knowledge for the important parameter, the threshold value of chloride ion concentration, which changes the passive stage to an active corrosion stage. A demonstration of this can be seen in Figure 2. Normally the reader believes that the sample with the lowest chloride concentration is preferable. Figure 2 demonstrates that the situation can be the opposite.

Furthermore, we are nowadays often discussing the effect of the most incredible products which the industry would like to use in a concrete mix. Normally those products are characterized as more or less waste materials. The owner of such a material will naturally try to increase the value by selling it to the concrete industry. Therefore the normal procedure is, some comparison tests, in a laboratory, or a few of the parameters which appear to produce good behaviour for only specific properties. This report will demonstrate that a laboratory comparison procedure which is not calibrated to a long term field exposure could not be used in service life prediction.

Finally service life of concrete structures is not ended at the moment an active stage will propagate the deterioration. Research on high performance concrete of different compositions indicate that in some extremely dense materials the rate of corrosion will be limited to values which we normally call a passive stage. Also cracks in such materials will be more tolerable due to small possibilities to form an electrolytic macro cell.

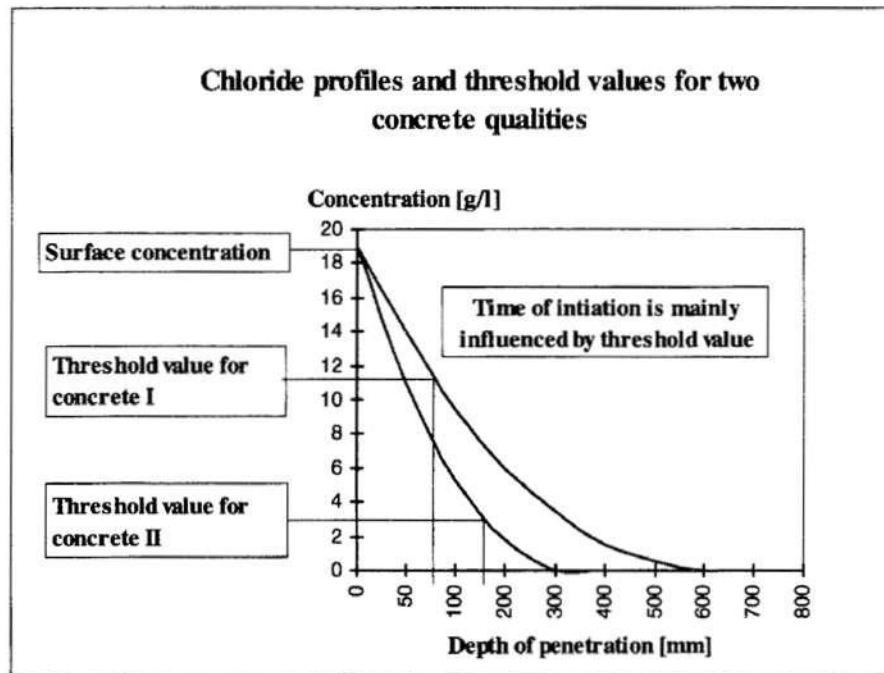

Figure 2 Schematic sketch of the time of initiation for two different concretes as a function of depth, Tuutti /1993/.

2 PARAMETERS IN THE CORROSION INITIATION MODEL

The length of the initiation period is determined by how rapidly the concrete cover is depassivated as a result of the fact that chloride ions penetrate to the steel, and by the concentration which is required to start the corrosion process. The penetration sequence is normally described as a diffusion process. In practice, the transport is not always quite so clearcut but is rather a combination of capillary suction and diffusion. One example of this is the fact that partly dried-out concrete absorbs a chloride solution through capillary suction. However, the diffusion model can be used with some modifications.

In constant wet environments as below the ground and sea water level the diffusion model describe the chloride penetration.

In varying environmental conditions such as the splash zone, concrete near roads etc the moisture conditions are varying by time. In drying periods water will evaporate from the concrete and the salts are remained in the pore water which is still in the pores. The concentration of different salt solutions are then increasing in the pore water as a function of evaporated water. In wet periods water is quickly absorbed through capillary suction which will increase the total amount of salts in the concrete if the water contains such substances. Structures which are not sheltered from rain will also be washed out of chloride ions when the rain water is flowing over the surface.

The chloride concentration will therefore be fluctuating in a surface zone, the convective zone, and reach a limit maximum value inside the concrete. The diffusion process will describe the chloride penetration behind this convective zone, see Figure 3.

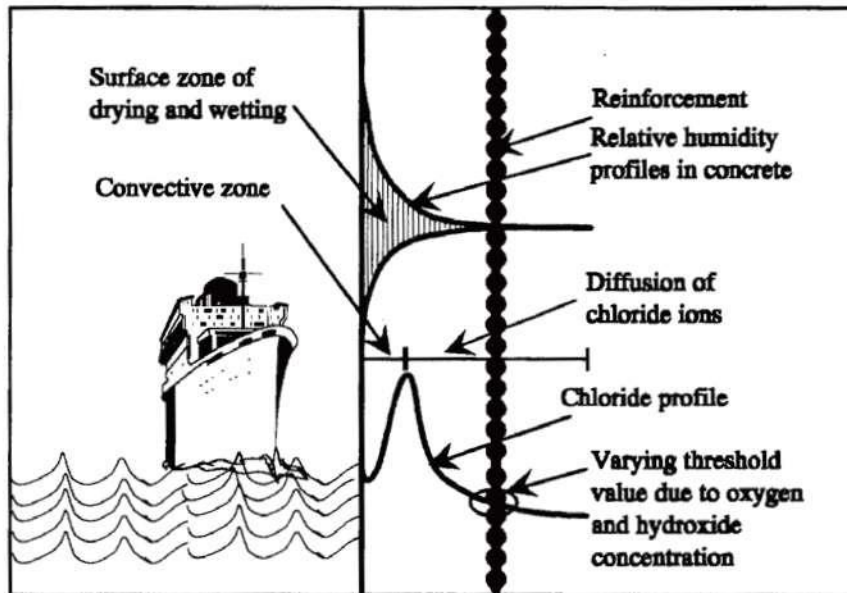

Figure 3 Schematic sketch of the moisture and the chloride variation in concrete in the splash zone, Sandberg /1993/.

Mass transport as a result of diffusion gives the following parameters when studying the initiation period.

- concentration difference, the ambient concentration minus the initial concentration of chloride ions
- transport distance, the thickness of concrete cover
- the permeability of the concrete against chloride ions
- the capacity of the concrete for binding chloride ions
- the threshold value which is required for initiation of the process of corrosion

The depth of the convective zone depends on the

- wetting and drying time
- time of capillary suction during wetting
- permeability of the concrete against water
- difference in vapor pressure

A numerical calculation method of this convective zone, based on a material study, have been developed by Arfvidsson and Hedenblad /1991/. The prediction method will also account the effect of a capillary suction in the wetting procedure. Demonstration of the effect of the primary parameters will give one more piece in the corrosion puzzle, see Figure 4. Small concrete covers and/or high permeable concrete will decrease the internal environmental homogeneity of the oxygen concentrations, ion concentrations and moisture conditions. These variations will primary influence on the chloride threshold value in the initiation procedure.

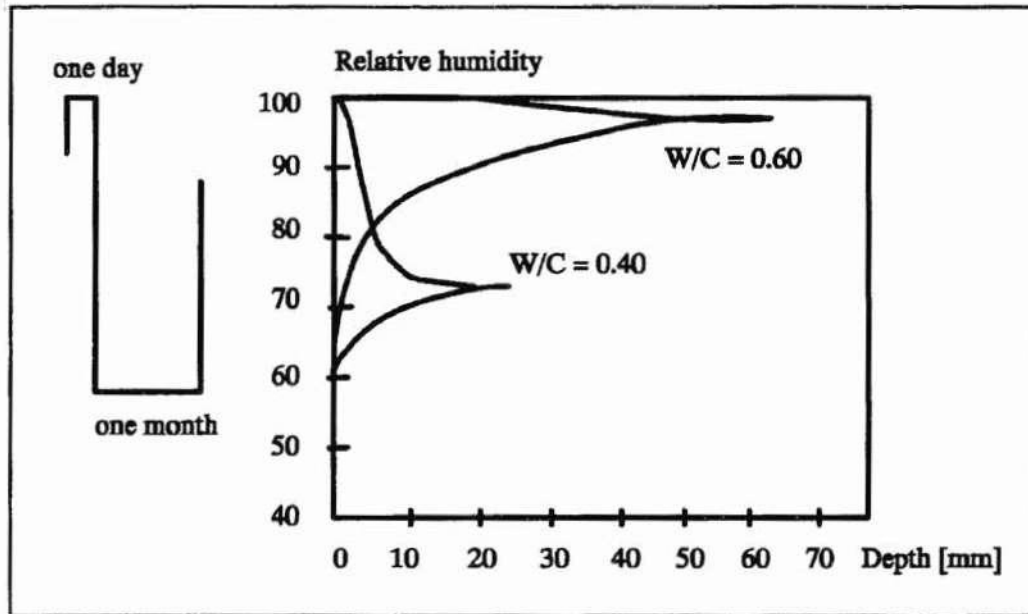

Figure 4. Demonstration of the moisture variation in two different concretes, W/C 0.40 respective 0.60, with an environmental cycling of 1 day capillary suction and 1 month drying in RH = 60%, Arfvidsson and Hedenblad /1991/.

Concrete with low permeability could raise special conditions by clogging the pores for diffusing ions. Concrete in a marine environment has been examined for several years now in Sweden and such clogging effects have been measured. A relatively high permeation occurred the in first year of exposure with values on diffusion coefficients comparable to values measured in laboratory experiments. However, a dramatic decrease could be seen for almost all concrete tested. Estimated values gave approximately one magnitude lower diffusion coefficient after an exposure time of ten years. In such conditions we have to use unsteady state conditions in calculation of chloride penetration.

Studies of moisture conditions in different qualities of concrete started by professor Göran Fagerlund and his students have demonstrated that low water cement ratios specially with addition of silica fume will almost stop all water fluctuations in the inner parts of a concrete structure. Concrete exposed during several years to water will decrease in relative humidity to such levels that steel corrosion will be very slow. Water is an essential substance in an electrochemical process. Corrosion of a metal occurs only in reactions in which both an anode and a cathode are connected by an electrolyte and with the metal. A low relative humidity will disconnect such electrolytic cells which will decrease the distance between the anode and the cathode as a function of resistivity. Such limitations will increase the common homogeneity and therefore increase the threshold value.

Sneck /1977/ made several tests on steel bars with a thin phase of a cement paste surrounding the metal. Different grades of concrete with large amounts of calcium chloride added were used to create a corrosive environment. The idea was to couple two environments, normal concrete in contact with a high chloride concentration, to create an electrolytic cell and study the progress of corrosion. Sneck thought that his

tests failed, due to the formation of a passive stage were no corrosion occurred in all the samples, even with an addition of 5% CaCl_2 by weight of cement. However, the thin phase of a homogeneous material surrounding the metal increased the threshold value to levels which normally are very corrosive. This test demonstrates very adequately the unpredictable corrosion cell formation and second that small micro effects will have a dominant influence on the threshold value for chloride initiated corrosion.

The conclusion from these reported experiences is that cracks in the concrete cover, which is one of the most common defects in concrete, will definitely affect the formation of corrosion cells. Consequently a scientific approach to the effect of cracks in different macro and micro environments is one of the most interesting areas for future research.

In the Swedish "High Performance Concrete" project and the research activities done mainly by Karin Pettersson, CBI and Paul Sandberg, Cementa, and reported by Fidjestøl, Jørgensen, Pettersson, Sandberg, Tuutti /1997/, several threshold values have been measured for different concrete qualities surrounded by typical natural chloride contaminated environments. The highest threshold values were found in the most constant conditions, concrete immersed in sea water, and with an internal high hydroxide concentration. Additions which will decrease the hydroxide concentration will result in a decrease of the threshold value. A surrounding environment with a fluctuating moisture condition, such as a splash zone, decreases the homogeneity which has a positive effect in the constitution of corrosion cells and will reduce the threshold value, see figure 5.

The permeability of the concrete which is not here been discussed in detail has of course a major influence on the rate of chloride penetration. A change of the diffusion coefficient with a factor of 10 will approximately change the depth of penetration for a specific concentration by a factor of the square root of 10. In addition, unsteady state conditions due to clogging effects emphasize that special considerations must be taking into account in the prediction of the diffusion coefficient.

Binding of chloride ions, often discussed in the literature, has only a minor effect on the time it takes to reach a high chloride concentration in concrete. However, binding of chloride ions has, of course a considerable influence on the maximum penetration depth due to immobilisation of ions at the front of the reaction, Tuutti /1993/.

A synthesis of the discussions above indicate that the most essential parameter in the process of corrosion initiation is the threshold value, specially if the threshold value is close to the surface concentration. The result also indicate that OPC concrete with a small amount of silica fume may be the most optimum binder mix in chloride rich sea water environments.

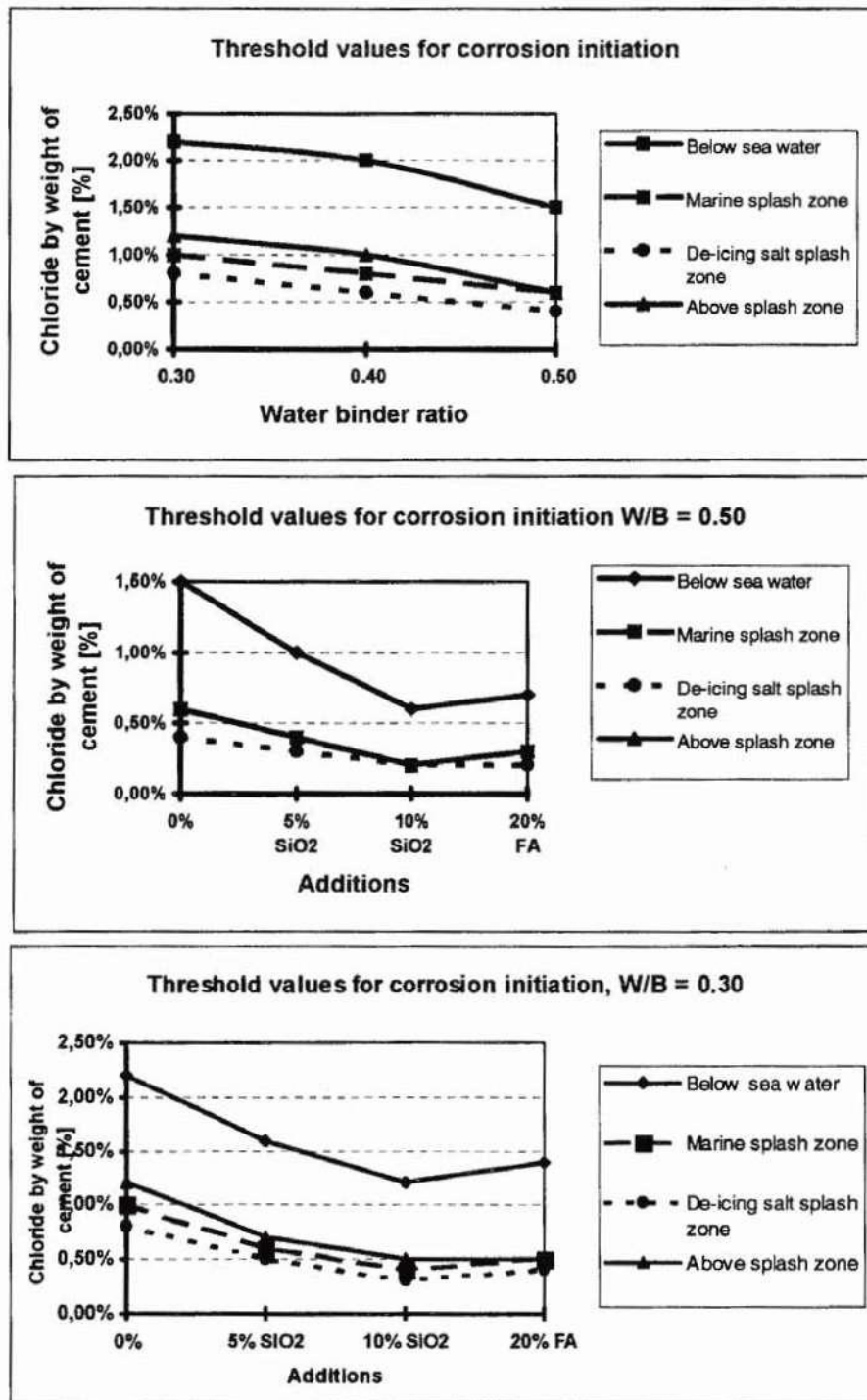

Figure 5. Influence of water binder ratio and mineral additives on the chloride threshold value in uncracked concrete at various exposure conditions. Fidjestøl, Jørgensen, Pettersson, Sandberg, Tuutti /1997/.

By use of measured chloride penetration the effective diffusion coefficients have been calculated from all samples in the Swedish field test program. A couple of these results are presented in figure 6. As in all other papers, where the chloride penetration is discussed, the effect of mineral additives, such as PFA and silica fume, reduce the rate of penetration.

However, the main task is, if this reduction will match the reduction of the threshold value showed in figure 5. By use of the simple hypothesis that chloride ions will penetrate by diffusion, with a constant diffusion coefficient and with a chemical reaction directly proportional to the concentration, it is possible to compare the initiation time of corrosion for different compositions. These theoretical calculations are summarised in table 1.

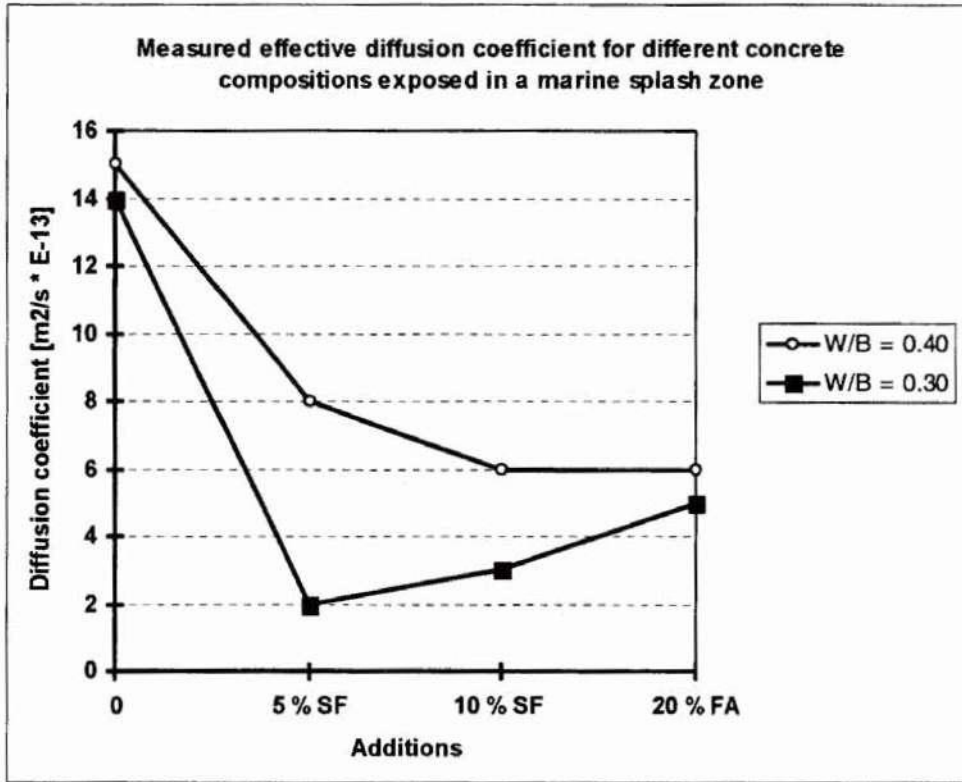

Figure 6. Measured effective diffusion coefficient for different concrete compositions. Fidjestøl, Jørgensen, Pettersson, Sandberg, Tuutti /1997/

Table 1: Calculated relative corrosion initiation periods for different compositions. The surface concentration has been estimated to 36 g Cl⁻/litre which is about twice as high as the normal concentration in sea water. The field exposure tests indicate that the concentration in the concrete pores is higher than in the surrounding environment.

Concrete composition	W/B = 0.50	W/B = 0.40	W/B = 0.30
100% OPC	0.35	1.00	3.20
95% OPC + 5% SiO ₂	0.25	0.75	4.50
90% OPC + 10% SiO ₂	0.15	0.75	1.25
80% OPC + 20% PFA	0.10	0.60	0.90

The results presented in table 1 indicate that the effect of silica fume will be optimum in high performance concrete. The effect of PFA is negative for all compositions. Use of 100% OPC is optimum for all compositions with W/B > 0.40. Thus, the Swedish tests indicate that the reduction of chloride permeability, by additions of mineral additives, is not as effective as the high threshold value in OPC concrete.

However, the most effective parameter, inducing a long initiation period is the use of a low water binder ratio.

3 PROPAGATION STAGE

The electrochemical process operates after initiation through a cathode and an anode simultaneously. Thus the cathode and the anode will steer the deterioration propagation. A small anode with a large cathode will generate a small but deep corrosion attack called pitting, compared with opposite conditions where deterioration is the type of general corrosion which is insignificant and more harmless for the load bearing capacity. Carbonation of the concrete cover will generate general corrosion and aggressive ions as chlorides normally produce pitting corrosion. Carbonation is not a problem today due to a common awareness of the problem, which has resulted in use of a relatively high concrete quality, low water cement ratio and thick concrete covers with small tolerances. Therefore conditions reducing availability of the progress of reactions either at cathode or anode are of interest in chloride rich environments.

The rate of corrosion could be effectively reduced by drying out the concrete close to the steel. Without any electrolyte the progress of corrosion is impossible. However, completely dry concrete is not a practical solution. The fine porous material, concrete, will always be in balance with the relative humidity in the air. On the other hand variations in the air could not be followed by the inner parts of concrete due to the low permeability. Seasonal as well as weekly variations will produce significant effects on the micro climate in concrete. Capillary suction from condensed water or rain will promote a more drastic effect for normal concrete, water cement ratios > 0.50 where water could easily be transported into concrete but with a slow evaporation.

Special concrete with water binder ratios < 0.40 and with use of silica fume is more impermeable and could keep dry conditions even after long periods of water exposure. The effect on the rate of corrosion is great. Concrete exposed to corrosive environments such as bridges, harbours and roads could reduce the rate of corrosion by one magnitude by using such a high performance concrete.

In the Swedish project the rate of corrosion has been measured with both the Spanish corrosion meter developed by ITCCT and Geocisa and with weight loss from steel bars. In concrete with $w/c = 0.5$ to 0.75 measured corrosion rates were 5 to $40 \mu\text{m}/\text{year}$. This could be compared with a corrosion rate of $2 - 3 \mu\text{m}/\text{year}$ measured on a concrete with $w/c < 0.40$ containing 10% silica fume by weight of cement.

Swedish conditions, seasonal variations on moisture and temperature, give a propagation period between 5 to 10 years before cracking of the concrete cover occur. According to measured corrosion rates for normal concrete the total amount of steel loss in the process will vary between 50 to $200 \mu\text{m}$. A rate of 2 to $3 \mu\text{m}/\text{year}$ is very close to a passive stage and indicates a propagation period of 20 to 100 years for high performance concrete. This is interesting considering calculated service life of 50 years for investments in buildings and 120 years for investments in civil engineering structures.

4 A MORE ADVANCED DIFFERENTIATION OF STRUCTURES IN MICRO ENVIRONMENTS

Practical experiences have demonstrated that concrete could have relatively short service life in specific environments such as edge beams in bridges and splash zones in marine environments. However, very seldom do we see a total destruction due to corrosion of reinforcement. A more detailed analysis has showed that a bridge will have different micro environments.

Concrete below the sea will be fully saturated with water but with the fastest chloride penetration compared with other parts in the bridge. This environment is often simulated in laboratory tests and is called diffusion test. The water filled pore system has a positive corrosion reduction effect caused by the low solubility of oxygen in the water. The corrosion rate will be extremely low and could be compared with a passive stage. Therefore low concrete qualities with high permeability is still in service after half a century. No precaution is necessary for that type of structural element.

Concrete in the splash zone is not fully saturated and will during certain periods dry out. The chloride penetration is not as fast as in the immersed zone. Some measurements indicate a penetration rate of half that which is in the immersed zone. The splash zone is the most corrosive part in the bridge and all concrete is normally designed for this environment. However, special protection systems could give a cost benefit for the contractor and the owner. Typical protection systems are extra concrete cover, use of stainless steel qualities or an extremely high performance concrete.

The atmospheric zone above the splash zone will gradually be exposed to less chlorides the higher up the concrete is situated. Norwegian studies have showed that also the wind direction will influence the chloride exposure. A direct wind load will also wash out chlorides during rain periods and there will be less chloride contamination on the affected side.

In Scandinavia climate, de-icing salts are used during winter periods which seriously influence the chloride penetration process and the initiation of the process of corrosion. All structural concrete parts that will be exposed to de-icing agents will be as severely affected as the concrete in the splash zone. A proper design for example the use of tubes transporting water to the ground or membranes separating water from constructional parts, could reduce exposed areas and also reduce the cost of investments.

Based on the discussion above a more systematic use of available research in the design of concrete structures could give increased cost benefits. Examples of such innovations could be the use of high performance concrete, protection systems, use of structural elements which could be repaired or replaced easily.

5 REFERENCES

- Andrade, Alonso, Rodrigues and Garcia: Cover cracking and amount of rebar corrosion: importance of the current applied accelerated tests. *Concrete in The Service Of Mankind*, Dundee 1996.
- Andrade C: personal communication, Institute of Construction Sciences 1996.
- Somerville G: personal communication, British Cement Association 1997.
- Arfvidsson and Hedenblad: Calculation of moisture variation in concrete surfaces, University of Lund 1991, *Building Materials & Building Physics*.
- Byfors, K. Chloride initiated reinforcement corrosion. Swedish Cement and Concrete Research Institute, Report 1:90, Stockholm 1990.
- Fagerlund G: personal communication, Lund Institute of Technology 1997.
- Fidjestöl, Jørgensen, Pettersson, Sandberg, Tuutti: Swedish manual for high performance concrete, Swedish Cement and Research Institute Stockholm 1997.
- Lambert, Page and Vassie. Investigations of reinforcement corrosion. 2. Electrochemical monitoring of steel in chloride-contaminated concrete. *Materials and Structures*, Vol. 24, No. 143, 1991.
- Pettersson, K. Corrosion threshold value and corrosion rate in reinforced concrete, CBI Report 2:92, Swedish Cement and Concrete Research Institute, Stockholm 1992.
- Pettersson and Woltze. Fältförsök beständiga marina betongkonstruktioner, Delrapport 1, Rapport nr 92057, Swedish Cement and Concrete Research Institute, Stockholm 1992.
- Sandberg, P. Kloridinitierad armeringskorrosion i betong, University of Lund 1992, *Building Materials*, TVBM-7032.
- Sandberg, Pettersson, Arup, Tuutti: Cost effective design of high performance concrete structures exposed in saline environment. *Concrete in The Service Of Mankind*, Dundee 1996.
- Sneck, T: personal communication, VTT Finland, 1977.
- Tuutti K: Stålets korrosionsförlopp i en osprucken betong, CBI fo 4:1977, Swedish Cement and Research Institute, Stockholm 1977.
- Tuutti K: Corrosion of steel in concrete. CBI fo 4:1982, Swedish Cement and Research Institute, Stockholm 1982.
- Tuutti K: The effect of individual parameters on the chloride induced corrosion. Nordic Miniseminar, January 1993. Chalmers Institute of Technology.

KFS AB • Lund • 1997