



LUND UNIVERSITY

Effects of Vagus Nerve Stimulation and Ketogenic Diet on Quality of Life and Changes in EEG and Sleep

Hallböök, Tove

2006

[Link to publication](#)

Citation for published version (APA):

Hallböök, T. (2006). *Effects of Vagus Nerve Stimulation and Ketogenic Diet on Quality of Life and Changes in EEG and Sleep*. [Doctoral Thesis (compilation), Paediatrics (Lund)]. Department of Clinical Sciences, Lund University.

Total number of authors:

1

General rights

Unless other specific re-use rights are stated the following general rights apply:

Copyright and moral rights for the publications made accessible in the public portal are retained by the authors and/or other copyright owners and it is a condition of accessing publications that users recognise and abide by the legal requirements associated with these rights.

- Users may download and print one copy of any publication from the public portal for the purpose of private study or research.
- You may not further distribute the material or use it for any profit-making activity or commercial gain
- You may freely distribute the URL identifying the publication in the public portal

Read more about Creative commons licenses: <https://creativecommons.org/licenses/>

Take down policy

If you believe that this document breaches copyright please contact us providing details, and we will remove access to the work immediately and investigate your claim.

LUND UNIVERSITY

PO Box 117
221 00 Lund
+46 46-222 00 00

Department of Clinical Sciences,
Divisions of Paediatrics and Clinical Neurophysiology
Lund University Hospital
Lund, Sweden

EFFECTS OF
VAGUS NERVE STIMULATION
AND KETOGENIC DIET
ON QUALITY OF LIFE AND CHANGES
IN EEG AND SLEEP

Tove Hallböök

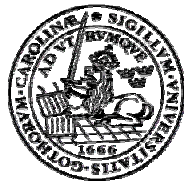

LUND
UNIVERSITY
Faculty of Medicine

2006

CONTENTS

CONTENTS	5
LIST OF PAPERS	7
ABBREVIATIONS	8
ABSTRACT	9
INTRODUCTION	11
<i>History</i>	<i>11</i>
<i>Definitions</i>	<i>12</i>
<i>Co morbidity</i>	<i>13</i>
<i>Epilepsy as a progressive disorder</i>	<i>13</i>
<i>Electro-encephalogram (EEG)</i>	<i>13</i>
<i>Sleep</i>	<i>14</i>
<i>Vagus Nerve Stimulation (VNS)</i>	<i>16</i>
<i>Ketogenic Diet (KD)</i>	<i>18</i>
<i>Present situation</i>	<i>19</i>
AIMS OF THE STUDY	20
STUDY DESIGN	21
PATIENTS	22
METHODS	23
<i>VAGUS NERVE STIMULATION</i>	<i>24</i>
<i>KETOGENIC DIET</i>	<i>24</i>
<i>SEIZURE FREQUENCY AND SEVERITY (Paper I-IV)</i>	<i>24</i>
<i>COGNITIVE FUNCTIONING (Paper I)</i>	<i>25</i>
<i>QUALITY OF LIFE, BEHAVIOUR, MOOD, DEPRESSION AND ATTENTIONAL BEHAVIOUR (Paper I-IV)</i>	<i>25</i>
<i>QUANTIFICATION OF EPILEPTIFORM ACTIVITY (Paper II, III and V)</i>	<i>26</i>
<i>SLEEP SCORING AND DELTA POWER ANALYSIS (Paper III and IV)</i>	<i>29</i>
<i>STATISTICAL METHODS</i>	<i>29</i>

RESULTS AND COMMENTS	30
<i>VAGUS NERVE STIMULATION</i>	31
<i>Seizure frequency and severity</i>	31
<i>Cognition, behaviour, mood and QOL and their association to seizure frequency and severity</i>	32
<i>Interictal epileptiform discharges and electrographic seizures</i>	32
<i>Pilot study – Correlation between visual inspection and Persyst Spike Detector System</i>	34
<i>Side effects</i>	34
<i>Sleep structure, delta power and movement times and the association to clinical effects on seizure frequency, seizure severity and QOL</i>	35
<i>Immediate effects of VNS on interictal epileptiform discharges and spectral power</i>	36
<i>KETOGENIC DIET</i>	37
<i>Sleep structure and clinical effects on seizure frequency, seizure severity, attentional behaviour and QOL and their correlation</i>	37
<i>Side effects</i>	38
GENERAL DISCUSSION	40
<i>Future aspects</i>	44
CONCLUSIONS	45
SUMMARY IN SWEDISH	45
ACKNOWLEDGEMENTS	48
REFERENCES	49
PAPERS I-V	59

LIST OF PAPERS

This thesis is based on the following papers, which are referred to in the text by their Roman numerals.

- I Vagus nerve stimulation in 15 children with therapy resistant epilepsy; its impact on behaviour, mood and quality of life.
Hallböök T, Lundgren J, Stjernqvist K, Blennow G, Strömblad L-G, Rosén I.
Seizure 2005;14:504-513

- II Long term effects on epileptiform activity with vagus nerve stimulation in children.
Hallböök T, Lundgren J, Blennow G, Strömblad L-G, Rosén I.
Seizure 2005;14:527-533

- III Beneficial effects on sleep of vagus nerve stimulation in children with therapy resistant epilepsy.
Hallböök T, Lundgren J, Köhler S, Blennow G, Strömblad L-G, Rosén I.
Eur J Paed Neurol 2005;9:399-407

- IV Ketogenic diet decreases night sleep and improves sleep quality in children with therapy resistant epilepsy.
Hallböök T, Lundgren J, Rosén I.
Accepted for publication in Epilepsia

- V Immediate effects of vagus nerve stimulation on inter ictal epileptiform discharges and EEG spectral power.
Hallböök T, Jarbo P, Rosén I.
Manuscript

Reprints were made with permission from the copyright owners.

ABBREVIATIONS

AED	Anti epileptic drug
CBCL	Child behaviour checklist
CSWS	Continuous spike wave during slow sleep
DR	Dorsal raphe nuclei
EMG	Electro-myogram
EEG	Electro-encephalogram
EOG	Electro-oculogram
IEDs	Interictal epileptic discharges
IEI	Interictal epileptiform interval
KD	Ketogenic diet
LC	Locus coeruleus
MRI	Magnet resonance imagine
MTs	Movement times
NCP	Neuro cybernetic prosthesis
NHS3	National health seizure severity scale
PB	Parabrachial nucleus
PSG	Polysomnography
QOL	Quality of life
REM	Rapid eye movements
SCN	Supra chiasmatic nucleus
TS	Total sleep
TDS	Total day sleep
TNS	Total night sleep
VAS	Visual analogue scale
VLPO	Ventro lateral preoptic nucleus
VNS	Vagus nerve stimulation

ABSTRACT

When anti-epileptic drugs fail, and epilepsy surgery is found unfeasible or ineffective, there remains a group of at least 25% of children with epilepsy in whom seizure control cannot be achieved. Vagus nerve stimulation (VNS) is an adjunctive treatment for medically refractory epilepsy. It is performed with an implantable, multi-programmable pulse generator that delivers current electrical stimulation to the vagus nerve for the purpose of suppressing and reducing the frequency and/or severity of epileptic seizures. Ketogenic diet (KD) is a high fat, low carbohydrate and low protein diet that has been used for childhood therapy resistant epilepsy since the 1920s. It was developed to mimic the ketotic state of starvation.

The general aim of this thesis was to evaluate effects of VNS on epileptiform activity, delta power and sleep characteristics and to correlate these to clinical aspects on seizure frequency, seizure severity, behaviour, mood and QOL in children with therapy resistant epilepsy. Initially, and after three and nine months of VNS-treatment, 15 children were investigated. Sleep characteristics and clinical correlations were also evaluated after three and 12 months in 18 children with KD. A diary of seizure frequency and the National Hospital Seizure Severity Scale (NHS3) were collected.

In the first study (paper I) cognitive functioning was recorded, a visual analogue scale for validating QOL, Child Behaviour Checklist (CBCL) for quantifying behaviour problems, Dodrill Mood Analogue Scale and Birlson Depression Self-Rating Scale were used. Six of fifteen children showed a 50% or more reduction in seizure frequency; one of these became seizure-free. Two children had a 25-50% seizure reduction. Two children showed increased seizure frequency. In 13 of 15 children there was an improvement in NHS3. The parents reported shorter duration of seizure and recovery phase. There were no changes in cognitive functioning. Twelve children showed an improvement in QOL. Eleven of these also improved in seizure severity and mood and five also in depressive parameters.

In the second study (paper II) 24 hour ambulatory EEG monitorings for spike detection were used. This study shows that VNS reduces interictal epileptiform discharges (IEDs), especially in rapid eye movement (REM) sleep and delta sleep, and the number of electrographic seizures. It also shows a concordance between reduction in IEDs and electrographic seizures. There was no correlation between the extent of improvement in clinical data and the degree of spike reduction.

In the third and fourth study (paper III and IV) children with VNS and KD were examined with ambulatory polysomnographic recordings. Sleep parameters, and in VNS,

movement times (MTs), used to account for arousals were estimated. Our findings indicate that VNS counteracts known adverse effects of epilepsy on sleep and increases slow wave sleep. This possibly contributes to the reported improvement in well-being. We also see an increase in MTs. This arousal effect seems to be of minor importance for QOL and could possibly be related to the antiepileptic mechanisms in VNS. KD decreases night sleep and improves sleep quality. The improvement in sleep quality, with increased REM sleep, seems to contribute to the improvement in QOL.

In the fifth study (paper V) the 24 hour ambulatory EEG monitorings were used to study immediate effects of VNS stimulation on epileptiform activity, arousals and background frequency in EEG. The findings lend no support to earlier studies suggesting immediate VNS stimulation related changes in IEDs. There were no VNS related changes in background EEG frequency despite the significant increase in the number of MTs immediately related to the VNS stimulation periods. These findings indicate that the effects of VNS on seizures and total amount of IEDs cannot be explained by an immediate effect on arousal.

Key words: Epilepsy, vagus nerve stimulation, EEG, seizure frequency, spike detection, children, quality of life, mood, sleep, REM, slow wave sleep, delta power, ketogenic diet, attention, behaviour.

INTRODUCTION

History

Since ancient times the terms epileptic seizure and epilepsy have been used. It derives from the Greek epilambanein, to seize or to attack. The oldest document in which an epileptic seizure is described is from Mesopotamia (2200 B.C.). Hippocrates (460 B.C.) referred to the disease as the "sacred disease". Herodotus (450 B.C.) used the term "major disease". Galenos (130-200) was the first to classify epilepsy in different forms depending on the origin. Tissot (1728-1797) stated that all forms of epilepsy derived from the brain and some had their origin in a brain injury or disease and some were idiopathic. Hughlings Jackson (1835-1911) established a neuropathological basis for the epilepsies. He suggested that seizures were caused by "occasional sudden excessive rapid and local discharges of grey matter" and that generalized convulsions resulted from invasion of normal brain tissue by seizure activity initiated in the abnormal focus. He related the seizure semiology with the origin or start of a seizure. The development of the electroencephalogram (EEG) by Berger (1873-1941) and the first human EEG in 1924, confirmed Jackson's theory that electrical activity in the brain derives from the grey matter. It made it possible to differentiate epilepsy from other conditions residing in the brain [35].

In ancient times, epilepsy was thought to be inflicted by the Gods. Hippocrates claimed that epilepsy should be treated with diet and drugs and not magic. Sir Charles Locock reported in 1857 the efficacy of bromide in 14 out of 15 cases of hysterical epilepsy related to the time of menses. This replaced many antique remedies for seizure disorders. In 1912 Hauptmann incidentally observed the effect of Phenobarbital in epilepsy. Phenytoin was the first antiepileptic drug (AED) tested in animal models. Merritt and Putnam reported the clinical efficacy of phenytoin in epilepsy in 1938. Since then a great number of new compounds have been introduced [8].

Fasting as a treatment of epilepsy was described in the Bible and in texts from the Middle Ages. Hippocrates wrote that modifications of diet were required to treat epilepsy. Erasistratus in 300 BC wrote that one inclining to epilepsy should be made to fast without mercy and be put on short rations. In 1911 the first modern use of fasting in epilepsy in medical literature was reported by Guelpa and Marie in France, and in 1921, Geyelin reported to the American Medical Association the successful treatment of epilepsy by fasting in up to 25 days, by dr. Conklin. In 1924 the ketogenic diet (KD) was designed to mimic starvation at the Mayo Clinic [97].

In the sixteenth and the seventeenth century physicians described the use of a ligature around the limb in which a seizure commences to arrest its progress. When Odier showed that

ligatures are equally efficacious in arresting seizures caused by organic brain disease, the hypothesis that seizures originate from the limb itself was reviewed. Gowers attributed these findings to a raised resistance in the sensory and motor nerve cells in the brain that correspond with the limb involved. In the beginning of the nineteenth century Gowers reported several other ways of which sensory stimulation could prevent seizures from spreading e.g. pinching of the skin and inhalation of ammonia [17]. Almost a hundred years later Ranja and Lona demonstrated that afferent sensory stimuli could abort epileptic paroxysms in human [81]. In 1888 Corning performed the first primitive transcutaneous stimulation over the vagus nerve and observed a decrease in seizures [55]. Vagus nerve stimulation (VNS) was, however, forgotten as an antiseizure therapy until Zabara in 1972 demonstrated the effect of VNS in chemically induced seizures in dogs [111]. This led Terry et al to design a stimulator with flexible, intermittent parameters and an appropriate electrode that was used in an encouraging clinical study in epilepsy [100]. That peripheral stimulation of the vagus nerve can affect the brain and cause changes in EEG patterns in animal has been described since the 1930s [10, 22, 113].

The modern era of epilepsy surgery was introduced in 1886 by sir Victor Horsley. In the 1930s Penfield in Montreal developed epilepsy surgery activity and this became a model for other centres in USA and Europe [35]. Epilepsy surgery is an important treatment in a selected group of patients with pharmacologically therapy resistant epilepsy.

Definitions

Epilepsy is not one single disorder. It is a very heterogenous condition and current research indicates that **epileptic seizures have multi-factorial etiologies**. This includes a combination of genetic factors. In some children a known genetic factor such as a channelopathy, in others the predisposition for the generation of seizures, seizure severity or seizure frequency in addition to a structural abnormality e.g. malformation of cortical or vascular development, tumor, trauma, hypoxic-ischemic brain injury or CNS-infection. The **prevalence** of children with active epilepsy in Europe is 4.5-5 per 1000. The **incidence** rate is 70 per 100000 [29]. The cumulative risk of epilepsy until the age of 15 years is about 1% [92]. About 70% of the children can be successfully treated with one or more anti epileptic drugs (AED). Despite adequate antiepileptic treatment 30% of the children continue to have seizures or experience unacceptable pharmacological side effects [52]. For these children with **therapy resistant epilepsy** surgery for epilepsy has become a realistic therapeutic option with the aim of controlling seizures and preventing secondary epilepsy related damage. Resective surgery is a curative treatment when the epileptogenic zone can be identified. In a substantial number of children the epileptogenic zone cannot be identified or is located in a functional

brain area. Additional new AED will lead to seizure freedom in maximum 7% [53]. KD and electrical stimulation of the vagus nerve are efficacious treatments for children who are unsuitable candidates for resective surgery or who have experienced insufficient benefit of epilepsy surgery.

Co morbidity

In children with therapy resistant epilepsy at least two of three children have concomitant disabilities. The most frequent is mental retardation, followed by cerebral palsy and neuropsychological disturbances. Of the 65% with mental retardation and epilepsy about 40% have cerebral palsy and 24% neuropsychological disturbances [56, 98, 99]. Of children with therapy resistant epilepsy, and known brain lesion 58% have neuropsychological disturbances. This should be compared with 29% in children with well-controlled epilepsy and 7% in children with other chronic disorders [26].

Epilepsy as a progressive disorder

A number of studies and case reports give supportive evidence that epilepsy in general may be a progressive disorder in childhood [9, 15, 16, 54]. Risk factors for developmental delay that have been identified include early onset, severe seizure disorder with a high seizure frequency, polytherapy and extensive pathologic substrates [32, 102, 105]. The effects of frequent seizures on the developing brain which result in clinical evidence of brain damage and significant mental handicap, often in an already vulnerable brain with known co morbidity, present a clinical problem not only in treatment and care taking strategies but also in finding possible assessments for evaluating cognition, attention, mood, quality of life, depression etc in these severely handicapped children [95, 96].

Electro-encephalogram (EEG)

The electrical potentials that are recorded on the scalp reflect the overall synaptic activity of the neurons in the underlying regions of the brain, particularly the cerebral cortex.

The electrodes are placed according to the international ten-twenty system of electrode placement. The name of the system derives from measurements made at intervals of 10 or 20 per cent of the total distance between four landmarks (nasion, external occipital protuberance, left and right preauricular points). The normal EEG pattern is characterized by a background α -activity of 8-13 Hz derived from changes in postsynaptic potentials of pyramidal neurons and their dendrites in the cortex with projections from thalamus. This rhythmic activity is

blocked or desynchronised by different stimuli, i.e. noise and light. The background EEG also contains other activity frequencies in the β (>13 Hz), θ (4-7 Hz) and δ (<4 Hz) band. In children, as compared with adults, the EEG pattern is dominated by a larger amount of frequencies in the θ - and δ -band. In the encephalopathic or dysfunctional brain slow activities dominate. Another expression of this neuronal dysfunction is the incidence of hypersynchronous neuronal discharges, interictal epileptiform activity (spikes, sharp waves and spike-wave complexes). Epileptic seizures are initiated by a sudden onset of abnormally increased or hypersynchronous neuronal activity occluding the normal function and usually recruiting adjacent or more distal cortical areas into an abnormal discharge behaviour. Immediately following an epileptic seizure slow activities dominate. Duration of this postictal depression often depends on the severity and length of the epileptic seizure. AED can also change EEG activity [7, 37, 45].

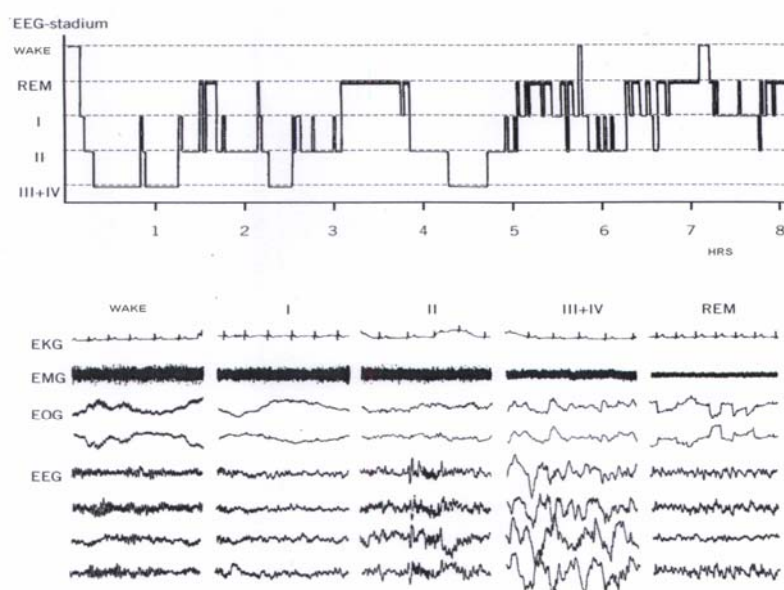

Figure 1. Example of a hypnogram, i.e. a sleep profile showing the alterations between the sleep stages during the night. Below: The polygraphic records during wakefulness and four stages of sleep: sleep stage 1, sleep stage 2, slow wave sleep (sleep stage 3+4), REM sleep. Tracings from top: Cardiac activity (EKG), muscle tension (EMG), eye movements (EOG) and cerebral activity (EEG). Jonsson, *Klinisk Fysiologi, Liber AB*, 2005.

Sleep

Until the 1950s it was assumed that sleep was a homogeneous or unitary phenomenon, which was the opposite of wakefulness. Already in 1936, Aserinsky and Kleitman described

the relationship between dreaming and a low voltage EEG pattern. In 1952 they discovered sleep periods with rapid, conjugated movements of the eyes, rapid eye movement [10]. During the following years the main types of sleep, that alternate rhythmically during the night, were described by Dement, Kleitman and Jouvet. One important step in the development of sleep research was the consensus of terminology, techniques and scoring of sleep that took concrete form in the manual edited by Rechtschaffen and Kales 1968 [82, 93]. At birth the amount of REM sleep and non REM sleep are about equal. The amount of REM sleep gradually decreases to 20-25%. Cycles of REM sleep are initially approximately of 45 minutes duration and gradually lengthen to 90 minutes by the age of five years. By three months K-complexes and sleep spindles are detectable. By six months a circadian rhythm in the sleep pattern becomes detectable. The total amount of sleep gradually decreases with age to reach about 10 hours in preadolescence. Environmental factors often have a significant impact on sleep in childhood [39, 46, 70, 74].

The Polysomnography (PSG) or somnopolygraphy is the simultaneous acquisition and coordinated analysis of two electrodes of an EEG, eye movements (electro-oculogram, EOG) and muscle tone (electro-myogram, EMG) [19]. Four stages of non REM sleep are recognized on conventional EEG criteria, these are categorized by frequency and amplitude and the presence of sleep-spindles and K-complexes, EOG and EMG [69] (Figure 1). Non REM sleep provides time for restorative processes. Cell division and protein synthesis are increased and anabolic processes and hormone excretion are favored. The characteristic electrophysiological features of REM sleep are fast desynchronized EEG frequencies, loss of EMG activity and presence of rapid eye movements. During REM sleep information obtained during wakefulness appears to be reprocessed and integrated into existing neural templates. The high proportion of the sleeping time occupied by REM sleep in neonates may reflect the neurodevelopmental needs of this age [23, 48]. The current methods of categorizing sleep into one or other state by conventional electrophysiological criteria probably give a false sense of rigidity to the constantly changing functional processes within the brain. The mechanisms responsible for generating non REM sleep and REM sleep are different, but both converge on the thalamus, which interacts reciprocally with the cerebral cortex to determine sleep or wakefulness. The drive to enter sleep increases with the duration since the end of the previous sleep episode. This intrinsic homeostatic drive appears to control non REM sleep. On the first night after sleep deprivation non REM sleep rebound appears. The threshold of entering REM sleep is under the control of an ultradian rhythm with 90 minutes cycle. This is not generated by sleep but increases with REM sleep deprivation. The suprachiasmatic nuclei (SCN) with fibres to the ventro-lateral preoptic nucleus (VLPO) of the hypothalamus are closely involved

in the circadian sleep-wake control, temperature regulation and hormone secretion [18, 86, 87].

Patients with frequent or medically intractable seizures have multiple sleep abnormalities including increased latency to sleep onset, increased number and duration of awakenings, decreased sleep efficiency, increased number of stage shifts and decreased or fragmented REM sleep [65, 101].

Vagus Nerve Stimulation (VNS)

Vagus nerve stimulation is delivered via the Neuro Cybernetic Prosthesis (NCP) System, Cyberonics, Inc. The NCP is an implantable, multi-programmable pulse generator with a bipolar lead, two stimulating electrodes and an anchor. The generator is seven millimetres thick, 50 millimetres in diameter, and it weighs 24 grams. The battery lifetime is between six and 11 years depending on the stimulation parameters. The VNS delivers current electrical stimulation to the vagus nerve for the purpose of stimulating the afferent nerve fibres and suppressing and reducing the frequency and/or severity of epileptic seizures. The VNS can be programmed externally with stimulation parameters appropriate to individual patients. It can also be activated by a handheld magnet. The VNS is implanted subcutaneously below the clavicle on the left side. The electrode coils are placed around the vagus nerve and the connecting lead is tunneled to the generator. (Figure 2) [40, 88, 100].



*Figure 2.
The pulse generator with a bipolar lead, two electrodes and an anchor. Photo Cyberonics.*

The vagus nerve lies within the carotid sheath between the carotid artery and the jugular vein. It is a mixed cervical nerve. Unmyelinated narrow-calibre C-fibres predominate over faster conducting, myelinated inter-mediate-calibre B-fibres and thicker A-fibres. VNS seems to excite the myelinated A- and B-fibres. In a study from Krahl et al VNS attenuated seizures equally well, whether or not vagal C-fibres had been destroyed [50]. The vagal efferents are parasympathetic projections to the heart, lungs, stomach, intestines, liver, pancreas and kidneys. These efferents originate in the preganglionic neurons. The vagus nerves are asymmetric with regards to cardiac innervation. The left vagus nerve carries most of the parasympathetic fibres that less densely innervate the heart. Measurements of cardiac rhythm with Holter monitoring, of respiratory function with pulmonary function test and of gastrointestinal parasympathetic effects with serum gastrin levels show little vagal activity during VNS [33]. We did Holter monitoring initially and after three months of VNS in the first ten children in our study, without any measurable changes in heart rate variability (unpublished). Each vagus nerve contains efferents that innervate the vocal cords and other skeletal muscles in the larynx and pharynx. Vocalization is commonly altered by VNS and stridor typically occurs during each train of stimulation. Swallowing can be affected, with anecdotal reports of aspiration at assisted feeding during VNS [60].

Afferents compose about 80% of the fibres in the cervical portion of the vagus. They project from the jugular and nodose ganglia to cortical and sub-cortical networks via the solitary tract and the nucleus of the solitary tract. From here there are widespread connections to many parts of the brain that are relevant for epileptic processes, wakefulness and sleep, such as the temporal lobe with the amygdala and hippocampus, thalamus and hypothalamus, the reticular formatio, and locus coeruleus [12], dorsal raphe nuclei (DR) and the ventrolateral preoptic nucleus (VLPO) (Figure 4). However, which systems that in particular are involved in these areas are unclear. The LC is the major source of norepinephrine in most of the brain and the DR provides widespread serotonergic innervation. Both norepinephrine, epinephrine and serotonin changes exert known antiseizure effects. Thalamus as a generator and modulator of cerebral activity has effects on EEG and epileptiform activity. Cortex, especially the amygdala-hippocampal-entorhinal cortex loop of the limbic system is site for complex partial seizures. The VLPO, LC and DR are strongly implicated in mood as well as in sleep regulation [42, 85, 91].

There have been no controlled trials of VNS in children. However the EO4 study, a prospective open safety study of VNS did include 60 children aged 3-18 years. After three months of stimulation the median reduction in the number of seizures was 23%, after six months 42%, after 12 months 34% and after 18 months 42% [68]. Another study with 95

children was a six-centre study. The average seizure reduction at three months was 36% and at six months 44.7% [41].

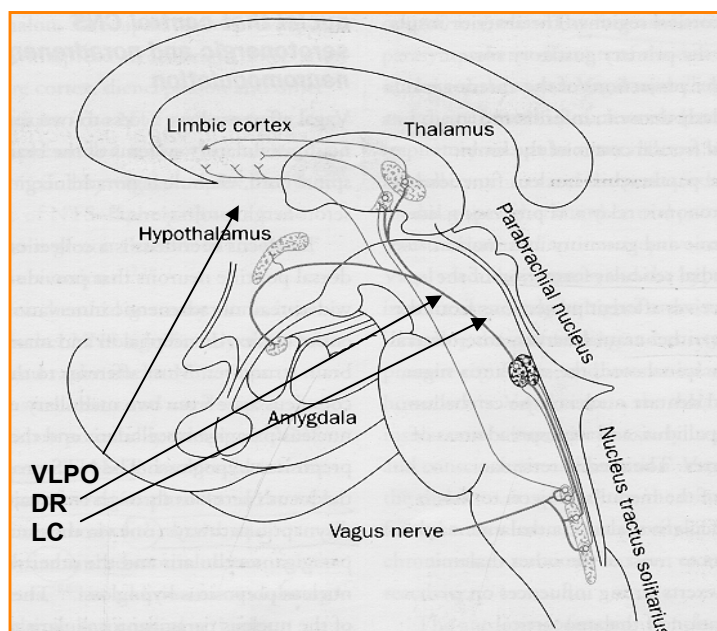

Figure 3. Ascending vagal projections. VLPO, Ventrolateral preoptic nucleus; DR, Dorsal Raphe nuclei; LC, Locus Coeruleus (From *Vagus Nerve Stimulation*, Schachter S and Schmidt D (eds), Fig. 1.3 p. 9, 2001)

Ketogenic Diet (KD)

KD is a high fat, low carbohydrate and low protein diet. It has been used for childhood therapy resistant epilepsy since the 1920s and was developed to mimic the ketotic state of starvation [97]. A standard approach to KD treatment includes a two-year diet period and a six to 12 months wean. Children are started on a 4:1 ratio, implying four grams of fat to one gram of combined protein and carbohydrate. The children also receive the recommended daily intake of vitamins and minerals, and supplementation of calcium and carnitine [30, 58]. Fasting and fall in blood glucose reduce plasma insulin production and stimulate lipolysis and production of fatty acids. Fasting is also up-regulating the MCT-1, monocarboxylic transport system of ketone bodies to the brain. Ketone bodies can pass directly into the neuronal mitochondria. Once in the mitochondria, beta-hydroxybutyrate is converted to acetoacetate and acetoacetate-CoA for the energy production of ATP in the Krebs's-cycle.

Efficacy and safety have been demonstrated in several studies. At least 50% of children with therapy resistant epilepsy achieve more than 50% reduction in seizure frequency [31, 71]. The reported improvement in attention, cognition and behaviour seems to be unrelated to the level of attained seizure control [80]. The basis for the improvement in both seizure control and behaviour is still unclear. There are different theories of the anti epileptic

mechanisms of KD and there is not one single mechanism of action. Increased cerebral energy reserves with decreased ictal excitability, decreased rate of glutamate transamination to aspartate and, possibly, enhancement in the rate of glutamate decarboxylation to GABA, may be some of the effects. Caloric restriction, the ketone bodies per se, amino acid flux, neuropeptide Y, galanin, norepinephrine and the polyunsaturated fatty acids are all intriguing candidates for mediators of the anticonvulsant effect of the KD [89].

Present situation

Current evidence shows that despite adequate antiepileptic treatment 30% of the children with epilepsy continue to have seizures or experience unacceptable pharmacological side effects. In this group the effects of frequent seizures on the developing brain result in clinical evidence of brain damage and significant mental handicap, often in an already vulnerable brain with known co morbidity. For these children with therapy resistant epilepsy, surgery for epilepsy has become a realistic therapeutic option with the aim of controlling seizures and preventing secondary epilepsy related damage. However, despite the promising results of surgery for epilepsy there remains a group of children that are unsuitable candidates for resective surgery or who have experienced insufficient benefits of epilepsy surgery. VNS is a useful palliative and less invasive and KD another efficacious treatment (Figure 5). The intention of this thesis was to evaluate effects of VNS on epileptiform activity, delta power and sleep characteristics and of KD on sleep characteristics and to correlate these to clinical aspects on seizure frequency, seizure severity, behaviour, mood and QOL in this group of severely handicapped children with therapy resistant epilepsy.

Hence this thesis is entitled: Effects of vagus nerve stimulation and ketogenic diet on quality of life and changes in EEG and sleep.

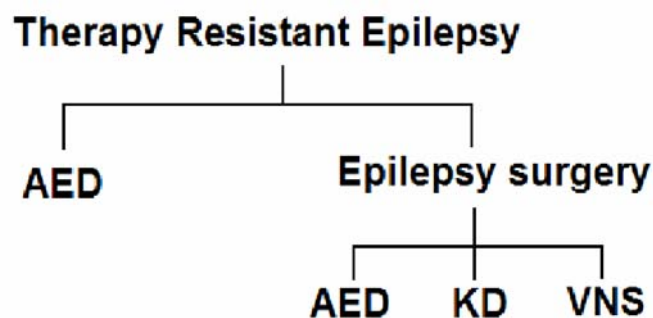

Figure 5. Treatment algorithm

AIMS OF THE STUDY

- To study effects of vagus nerve stimulation on cognition, behaviour, mood and quality of life and how these changes are related to effects on seizure frequency and severity in children with therapy resistant epilepsy.
- To investigate effects of vagus nerve stimulation on epileptiform activity and how these changes are related to activity stage and clinical effects on seizure frequency, seizure severity and quality of life in children with therapy resistant epilepsy.
- To evaluate sleep structure and delta power following vagus nerve stimulation and how these possible changes correlate with epileptiform activity and clinical effects on seizure frequency and quality of life in children with therapy resistant epilepsy.
- To evaluate sleep structure following ketogenic diet in children with therapy resistant epilepsy and to correlate possible alterations with changes in clinical effects on seizure reduction seizure severity, quality of life, attention and behaviour.
- To study possible immediate effects of vagus nerve stimulation on epileptiform activity, arousals and background frequency in EEG.

STUDY DESIGN

This thesis is based on two prospective longitudinal studies. All children were treated at the Department of Paediatrics, University Hospital in Lund, Sweden. Written informed consent was obtained. The studies were accepted by the Ethics Committee of the Faculty of Medicine of the Lund University. Each patient serves as his own control and was assessed initially and after three and nine months of VNS-treatment and after three and 12 months of KD-treatment (Figure 6).

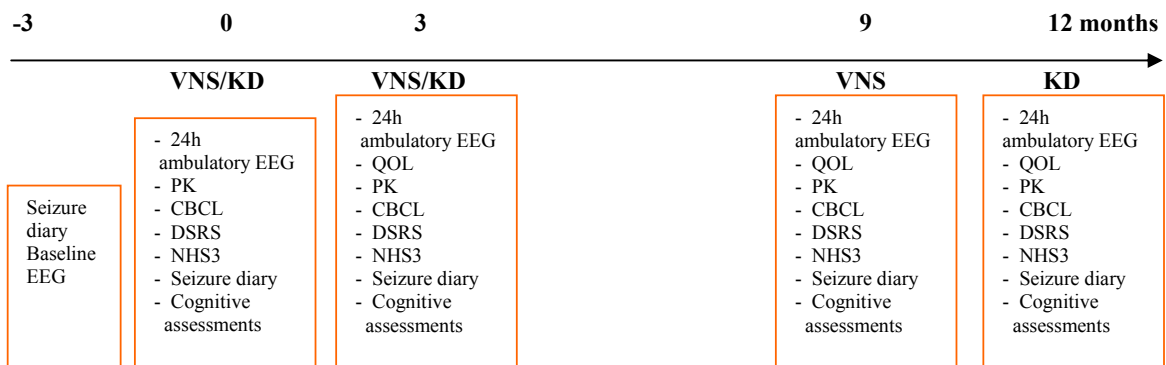

Figure 6.: Study design and chronology

CBCL, Child behaviour checklist; DSRS, Depression self-rating scale; NHS3, National health seizure severity scale; PK, Posford and Kinsella's rating scale of attentional-behaviour; QOL, Quality of life

PATIENTS

All children had the diagnosis of therapy-resistant epilepsy with developmental impairment and absence of non-epileptic seizures or specific sleep disorders. The seizure types, as well as the type of epileptic syndrome in the children were defined according to the classification of the International League Against Epilepsy (ILAE) [2, 3].

The first study group (paper I-III and V) comprises 15 children, ten boys and five girls aged 4-17 years (median 11 years) (Table 1). Epilepsy surgery had been performed in four children and found not applicable in the others. Age of epilepsy onset was between four months and nine years (median three years). Duration of epilepsy was 4-12 years (median 8.5 years). The etiology was unknown in three subjects. These three had normal MRI-scans. All children had been on stable AED medication for at least three months prior to the VNS initiation and during the nine months of follow up. Assessments were performed initially, before the VNS-implantation and after three and nine months of VNS-treatment.

Table 1 Demographics and clinical characteristics of the first study group

Patient no	Age at study onset (yr)	Age at epilepsy onset (yr)	Epilepsy type syndrome*	Seizure type*	Etiology	Previous epilepsy surgery	Changes in seizure frequency at 9 months (%)
1	10	0,25	L-G	GTCS	Unknown	No	increase (33%)
2	9	2,5	Part, Symt	CPS	CD	L TL res	seizure free (100%)
3	15	3	Part, Symt	CPS	Enc	No	reduction (5%)
4	4	1	Part, Symt	CPS	CD	R TL res	reduction (4%)
5	13	5	L-G	2°GTCS, AA	HIE	No	no change (0%)
6	11	4,5	CSWS	SPS, 2°GTCS	HIE	No	reduction (55%)
7	15	5	Part, Symt	SPS	HIE	No	reduction (50%)
8	9	0,5	L-G	2°GTCS	HIE	No	reduction (50%)
9	17	9	Part, Symt	CPS	CD	No	increase (16%)
10	6	0,75	Part, Symt	CPS, MS	Unknown	No	reduction (35%)
11	10	2	Part, Symt	2°GTCS	CD	L par-occ res	reduction (5%)
12	11	0,25	L-G	GTCS, AS, MS	CD	R F and occ res	reduction (25%)
13	16	7	Part, Symt	CPS	HIE	No	reduction (78%)
14	12	3	Part, Symt	CPS	Unknown	No	reduction (57%)
15	12	5	CSWS	CPS	Unknown	No	reduction (17%)

*Epilepsy and seizure types according to the International Classification of the International League Against Epilepsy AA, atypical absence; AS, atonic seizure; CD, cortical dysplasia; CPS, complex partial seizure; CSWS, continuous spike wave during slow sleep; Enc, encephalitis; F, frontal; GTCS, generalized tonic-clonic seizure; 2°GTCS, secondary generalized tonic-clonic seizure; HIE, Hypoxic ischemic encephalopathy; L, Left; L-G, Lennox-Gastaut; M, Myoclonic seizure; Occ, occipital; Par-, parieto-; Part, partial; Res, resection; R, right; SPS, simple partial seizure; Symt, symptomatic; TL, temporal lobe

The second study group (paper IV) comprises 18 children (nine boys and nine girls) aged 2-15 years (median 7.5 years) (Table 2). Epilepsy surgery had been performed in one patient (# 4) and found not applicable in the others. All patients had been on stable AED

medication for at least three months prior to the KD-initiation and during the 12 months follow up. Assessments were performed initially, before introduction of KD and after three and 12 months of KD-treatment.

Table 2 Demographics and clinical characteristics of the second study group

Pat No	Age at study onset (yr)	Age at epilepsy onset (yr)	AED	Epilepsy type/ syndrome*	Seizure type*	Etiology	Changes in seizure frequency at 3 months (%)	Changes in seizure frequency at 12 months (%)
1	7	3	SUX CLON	Gen	AD GTCS	Unknown	Decreased 99%	Decreased 99%
2	14	5	VPA LTG CLON	MAE	Tonic/Gen	Unknown	Decreased 90%	Decreased 40%
3	2	0,13	LTG Sulth CLOB Nitra	IS, L-G	AA GTCS	Unknown	Decreased 72%	Decreased 30%
4	11	0,25	LTG VPA CLON	IS, L-G	TC/2°GTCS	Asphyxia	Unchanged 0%	
5	5	2,5	OXC LTG	Gen L-G	AA AD TD	Enc	Decreased 90%	Decreased 89%
6	4	0,75	VPA CBZ	Part Crypt	Tonic/Gen	Unknown	Decreased 96%	Decreased 90%
7	8	5	AZT	Part Crypt	TC/2°GTCS	Unknown	Increased 50%	
8	4	Neonatal	LTG Nitra	Gen	TD MC	Asphyxia	Decreased 100%	Decreased 80%
9	5	2	VPA OXC	Gen	TC/2°GTCS	Enc	Decreased 22%	
10	9	Neonatal	LTG GBP CLOB	IS, Part Crypt	Tonic/Gen MC	Asphyxia	Decreased 72%	Decreased 85%
11	5	Neonatal	VGB VPA CLON	IS, Part Crypt	AA TD MC	Asphyxia	Decreased 40%	Decreased 88%
12	3	0,67	LTG Sulth CLOB	Part Crypt	Tonic/Gen	Unknown	Decreased 100%	Decreased 100%
13	9	Neonatal	VPA Nitra	IS, L-G	Tonic/Gen	Asphyxia	Decreased 30%	Decreased 37%
14	3	Neonatal	LTG TPM	Part Crypt	TC/2°GTCS	Unknown	Decreased 80%	
15	9	6	OXC CLON	Part Symt	TC/2°GTCS	Sp tumor, HC	Unchanged 0%	
16	13	2,5	TPM	Part Symt	GTCS	CMV	Decreased 67%	
17	6	1	LTG Sulth CLOB	L-G	TD MC	Asphyxia	Decreased 100%	Decreased 100%
18	15	0,5	LTG	Gen	AD	Glut-1- deficiency	Decreased 100%	

*Epilepsy and seizure types according to the International Classification of the International League Against Epilepsy AA, Atypical Absence; AD, Atonic Drop; AED, Anti Epileptic Drugs; AZT, Acetazolamide; CBZ; Carbamazepine; CLOB, Clobazepam; CLON, Clonazepam; CMV, Cytomegalovirus; Crypt, Cryptogenic; GBP, Gabapentin; Gen, Generalized; GTCS, Generalized Tonic Clonic Seizures; HC, Hydrocephalus; IS, Infantile Spasms; L-G, Lennox-Gastaut; LTG, Lamotrigine; MAE, Myoclonic Astatic Epilepsy; MC, Myoclonic; Nitra, Nitrazepam; OXC, Oxcarbamazepine; Part, Partial; Sp, Spinal; Sulth, Sulthiame; SUX, Suxinutin; Symt, Symtomatic; TC, Tonic Clonic; TD, Tonic Drop; TPM, Topiramate; VPA, Valproate

METHODS

VAGUS NERVE STIMULATION

In all children in the first study group (paper I-III and V) a VNS was implanted subcutaneous below the clavicle on the left side according to the established guidelines [1, 88]. At the end of the surgical procedure the device was programmed with the following parameters: output current 0.25 mA; signal frequency 30 Hz; pulse-width 500 μ seconds; stimulation on-time 30 seconds; stimulation off-time five minutes. During four weeks the output current was increased in steps of 0.25 mA to 1-1.5 mA and was then kept stable during the nine months follow up. Patient number 12 was changed to rapid stimulation (stimulation on-time seven seconds; stimulation off-time 12 seconds) after six months.

KETOGENIC DIET

All children in the second study group (paper IV) were admitted to the hospital and started gradually on the diet following a 12-hour out patient fast. The children were started on the classical KD. Fifteen children received a 4:1 and three a 3.5:1 ratio implying four grams or 3.5 grams of fat to one gram of combined protein and carbohydrates. Sixteen children were kept stable and two more changed from ratio 4:1 to 3.5:1 during the first three months and were then kept stable. The children also received the recommended daily intake of vitamins and minerals and were supplemented with calcium, magnesium, phosphorous, potassium and carnitine. The children were closely monitored to exclude intake of extra carbohydrates. In two children the diet was introduced via a gastrostomy tube, using Ketocal and a soymilk based ketogenic formula [30].

SEIZURE FREQUENCY AND SEVERITY (Paper I-IV)

Initially and after three and nine months of VNS-treatment (three and 12 months of KD-treatment) the parents or caregiver filled in a protocol over seizure frequency and were questioned about the nature and timing of any seizure occurring during the previous three months. Information about adverse effects, compliance with medication over the same period was asked for and plasma concentrations of AED were measured. The seizure severity was scored with the National Hospital Seizure Severity Scale, a further development of the Chalfont Seizure Severity Scale described by O'Donoghe et al. [73].

Methodologic consideration

The seizure types, as well as the type of epileptic syndrome in the children were defined according to the classification of the International League Against Epilepsy (ILAE) [2, 3]. The parents or caregiver filled in a protocol over seizure frequency and were questioned about the nature and timing of any seizure occurring during the previous three months. Parents' seizure frequency reports might be uncertain measures with a high rate of missed subtle seizures and undetected seizures during night. Myoclonic seizures were not scored.

COGNITIVE FUNCTIONING (Paper I)

Three different tests depending on the child's level of functioning were used. BSID, Bayley Scales of Infant Development, American version [11], WPPSI-R, Wechsler Preschool and Primary Scale of Intelligence, Swedish version [107], and WISC-III, Wechsler Intelligence Scales for Children, Swedish version [106]. For children assessed with BSID the Mental Developmental Index (MDI) was used to express the cognitive functioning and for children assessed with WPPSI-R and WISC-III full scale IQ was used. Assessments were performed in 14 children. In one child with severe mental retardation the parents only wanted to perform one assessment.

Methodologic consideration

Aldenkamp described that cognitive and behavioral assessments are difficult to use in patients with epilepsy and developmental impairment. Both testing and interpretation are challenging. Motor-, visual- and communication impairments are only some of the problems the testing psychologist has to deal with [5, 6].

QUALITY OF LIFE, BEHAVIOUR, MOOD, DEPRESSION AND ATTENTIONAL BEHAVIOUR (Paper I-IV)

These parameters were assessed by questionnaires and visual analogue scales filled in by the parents, usually the mother (in Birleson, the child together with the mother). To describe QOL a visual analogue scale [105] was used with scores between -10 - +10. Zero in the middle was the parent's conception of the child's QOL immediately before VNS-initiation, -10 was 100% reduction and +10 was 100% improvement of QOL.

Parents' perception of the children's general behavioural problems was quantified by using the total score of the Child Behaviour Checklist (CBCL) [4]. The questionnaire comprises 115 items and the parent was asked to rate, on a three point scale, whether a

behaviour problem was present or not in the child and to what degree. The cut-off score for manifest behaviour problems is 30 according to Swedish norms for the scale [57].

Mood was assessed by using a visual analogue scale (VAS), which consists of 100 millimetres scales for 18 dimensions (e.g. alert-drowsy; tense-relaxed), commonly reported in the literature to be sensitive to drug effects [27, 28]. The scale was translated and retranslated into Swedish.

For measuring depression Birleson depression self-rating scale (DSRS) was used. The scale has been translated into Swedish and the wording of the translation has made it acceptable both to children [34] and adolescents [47]. It is an 18-item self-report questionnaire in which the child is asked to estimate his/her own situation during the last week on a three-point scale. Scores of two, one or zero, respectively, in the direction of disturbance, refer to "most of the time", "sometimes" or "never".

Ponsford and Kinsella's rating scale of attentional behaviour (PK) is an instrument for quantifying attention. Each of fourteen selected items was rated by the parent on a scale from 0 to 4, representing the frequency with which the problem was apparent (0=not at all; 1=occasionally; 2=sometimes; 3=almost always; 4=always) [79].

Methodologic considerations

Even though major concerns have been raised regarding the accuracy and acceptability of parent rating of children's QOL we used the parent's conception of the child's QOL. Ronen et al demonstrated a tendency for parents to score lower than the child in QOL and performance status [83]. In very young children and in severely handicapped children measurements can be based only on parents report. Parent reports may be more reliable in long-term investigations because of rapid changes in children's attitudes, abilities and priorities as part of their developmental process. In the statistical analyse of QOL 0 was set as -10 or 100% reduction and 20 as 10 or 100% improvement. 10 was equal to zero, before VNS-initiation.

QUANTIFICATION OF EPILEPTIFORM ACTIVITY (Paper II, III and V)

Via the digital Embla A10 Flaga-Medcare system and a sampling rate of 200 Hz with 16 bits resolution, data were recorded on a PCMCIA memory flash card. The EEG data was recorded with 11 scalp electrodes and a referential electrode (F3, F4, C3, C4, T3, T4, P3, P4, O1, O2, CZ, Ref.) according to the international ten-twenty system of electrode placement. An additional electrode was applied to the left side of the patient's neck, over Erb's point, with a corresponding reference on the right side, to pick up the stimulus artefacts from the stimulation electrodes of the NCP device. The digitalized data were converted to Nervus

Tauragreining EEG format (Valor format). Twenty-four hour ambulatory EEG recordings, with the children in their natural surroundings were performed. Meals, naps, other activities, time of sleep and seizure events were registered in a diary. The epileptiform activity was counted in comparable assessment periods according to time of day and activity stage. Two hours of artefact-free EEG was selected from wake and one hour from REM sleep, non REM sleep stage two and slow wave sleep respectively, according to Rechtschaffen and Kales sleep criteria [82]. Periods of sleep during daytime, seizure events or disturbances in the recordings due to movement artefacts or technical problems were not selected. For three children, selected channels with continuous artefacts were excluded. The spike counting was based on the Persyst automatic spike detector system [110].

A **single blind pilot study** was performed comparing visual spike detection and the Persyst automatic spike detector system. In this study seven children encompassing altogether 21 hours of EEG were analysed. A common average montage was used. The automatic spike detection was performed in its most sensitive setting. All events were evaluated and edited for false detections. The visual identification of epileptiform activity was performed with a 5 Hz high pass filter and a 50 Hz low pass filter in consecutive 10 second periods. Each solitary spike or sharp wave with peak amplitude at least twice the local background activity was supplied with an event mark (Figure 7). No software for automated **electrographic seizure detection** was used. The 24 hour recordings were visually analysed and an electrographic seizure event was defined as an abrupt onset of rhythmic epileptiform activity of >10 seconds of duration.

Methodologic considerations

The incidence of interictal epileptiform discharges and seizures is modulated by unknown factors as well as known factors such as activity stage, REM - non REM sleep, sleep - waking cycle, real time of day, AED, time since last seizure and environmental factors. Although efforts are made to control for known influencing factors, the variability of the amount of interictal epileptiform discharges between consecutive days is considerable and larger in generalized than in focal epilepsies [20, 36, 63, 67]. In our study we used 24 hour recordings before initiation and at two consecutive occasions at three and nine months of VNS-treatment in order to minimize spontaneous variability. We selected long artefact-free recordings with comparable periods during the same real time of day. Over-night sleep recordings were done for quantification of sleep in order to get comparable periods in the different activity stages. AED were kept stable from three months before and through out the study, plasma concentrations were taken before initiation and at three and nine months of

VNS-treatment. The 24 hour EEG recordings were ambulatory, with the children in their natural surroundings.



Figure 7. Examples of event marks in an EEG recording. Comparison between the Persyst automatic spike detector system (above) and visual detection (below).

We based the identification of epileptiform discharges on the commonly used criteria [77]. But as pointed out by Gotman, the definition of a spike is not completely defined [38]. Automatic computerized spike detection methods have developed. Even though many improvements have been made the number of false negative or false positive detections are unknown. On the other hand electroencephalographers differs when asked to independently identify spikes of the same EEGs [44, 109].

SLEEP SCORING AND DELTA POWER ANALYSIS (Paper III and IV)

Somnopolygraphy, Delta power and Movement time

The 24 hour ambulatory EEG recordings (see quantification of epileptiform activity) was combined with a polysomnographic recording (PSG). In addition to the EEG, on the right side electro-oculogram (EOG) and sub-mental electro-myogram (EMG) were applied. The digitalized data were transferred to Somnologica 3.1 (Flaga hf. Medical Devices) for PSG analysis. Sleep parameters were scored according to Rechtschaffen and Kales sleep criteria [82]. We used the Somnologica automatic sleep scoring hypnogram with necessary corrections for overestimated slow wave sleep (SWS) and underestimated REM sleep. Sleep stages three and four were treated together as SWS.

Methodologic considerations

AED is known to influence sleep. Most AED cause sedation, this effect is usually transient. Sodium valproate increases total sleep, reduces sleep latency and reduces the number of sleep-stage shifts. In order to avoid these effects AED were kept stable from three months before and through out the study, plasma concentrations were taken before initiation and at three and nine months of VNS-treatment (three and 12 months of KD-treatment). The first night effect (FNE) is characterized by increased fragmentation of sleep architecture, increased sleep latency, decreased REM sleep and SWS. Very little data is available concerning FNE in patients with medically refractory epilepsy, a group of patients that are well experienced with EEG laboratory environment. Marzec et al reported in a study that the only parameter affected was SWS [64]. The 24 hour EEG recordings were ambulatory, with the children in their natural surroundings and not in sleep laboratory environment.

STATISTICAL METHODS

The data in this thesis was generally of non-normal distribution and was therefore analyzed with non-parametric tests, based on ranking. The patient groups were small and in

the evaluation of QOL and mood we used visual or linear analogue scales. Measures of location (variation) were consequently given as median (range or inter-quartile range).

Wilcoxon's signed rank test was used for comparison of the clinical data on seizure frequency, seizure severity, QOL, behaviour, mood, depression and attentional behaviour in paper I-IV. In paper II, Wilcoxon's signed rank test was used for comparisons of the total and mean number of IEDs and the median ISI in the different activity stages. It was also used for comparisons of total and mean number and duration of electrographic seizures during the 24 hour monitorings. In order to investigate possible changes in the variability of the ISI, the standard deviation of the ISI was calculated for each patient. In paper III and IV Wilcoxon's signed rank test was used for comparison of data from the hypnogram. Median time in minutes and percent of total night sleep (TNS) were analysed in REM sleep, sleep stage one, sleep stage two and SWS. In paper III, total number of movement times (MTs), MTs per hour TNS and number per sleep stage were analysed. Total delta-power during night-sleep, delta-power during SWS in the first and second sleep cycle, according to Rechtschaffen and Kales sleep criteria, were analysed.

The hypothesis of suppression of IEDs and absolute and relative spectral power in immediate correlation to the VNS epochs were investigated in 10 and 40 second intervals with Friedman's and Wilcoxon's signed rank tests. They were also performed to analyse the relation between MTs and the VNS epochs.

In paper II, the pilot study, i.e. the comparison between visual identification of epileptiform activity and Persyst automatic spike detector system, was single blinded, i.e. the scorer was kept blinded to the identity of the recorded subject and to the order of the recording. Correlation was measured with Pearson's linear correlation and Spearman's rank correlation. Wilcoxon's signed rank test was used for description of the difference.

In paper I, Kruskal-Wallis' test was used for comparison between three subgroups based on treatment effect (no, <50%, >50% seizure reduction), initially and after three and nine months of VNS-treatment.

A binomial test was used in order to check concordance in direction of changes between IEDs and electrographic seizures during the 24 hour EEG-monitorings in paper II and between increased SWS and MTs and reduction in epileptiform activity, seizure frequency, improvement in seizure severity and improvement in QOL and behaviour in paper III.

Spearman's rank correlation coefficient (r) was used to calculate the correlation in degree of improvement between QOL and seizure severity and seizure reduction in paper I, the extent of reduction between IEDs and seizure frequency in paper II, and degree of improvement between sleep parameters and clinical effects in paper III and IV. In general, significance was claimed when the p-value was less than or equal to 0.05.

RESULTS AND COMMENTS

VAGUS NERVE STIMULATION

Seizure frequency and severity

Six children had more than 50% seizure reduction. One of these became seizure-free. Two had between 25-50% seizure reduction and four had less than 25%. Seizure frequency increased in one and was unchanged in two. The median seizure reduction was 65% ($p=0,02$) at three months and 63% ($p=0,04$) at nine months. Considering seizure type, simple partial, complex partial and atonic seizures seemed to decrease more than other seizure types scored. Two children had myoclonic seizures that were not scored. In both, the myoclonic seizures ceased after three months of VNS-treatment. Seizure severity improved significantly both at three and nine months ($p<0,001$). The parents reported shorter seizure duration and recovery phase (Table 3).

Comments: These results are in accordance with earlier reports of a better and more rapid response in children compared with adults [41, 68, 75, 103, 108]. The improvement in seizure severity was significant. VNS is a palliative treatment and other parameters of efficacy than seizure frequency such as seizure severity must be considered. A child with milder seizures and shorter seizure duration and recovery may benefit more than a child who only shows a 50% reduction in seizure frequency. Parents' seizure frequency reports might be uncertain measures with a high rate of missed subtle seizures and undetected seizures during night. This could explain the lower concordance between interictal epileptiform discharges and clinical seizures compared to electrographic seizures during the 24 hour recordings (see below).

Table 3 Changes in clinical seizures, seizure severity, behaviour and QOL after 3 and 9 months of VNS-treatment

	Before VNS-initiation	3 months after VNS-initiation	9 months after VNS-initiation
	Median (range)	Median (range) p-value	Median (range) p-value
Clinical seizures	51 (2-200)	18 (2-141) $p=0.02$	19 (2-112) $p=0.04$
NHS3	12 (4-19)	9 (1-16) $p<0.001$	9 (1-16) $p<0.001$
QOL	10 (10-10)	15 (5-20) $p=0.04$	13 (2.5-17.5) $p=0.04$
CBCL	49 (19-94)	50 (19-102) $p=0.69$	43 (18-92) $p=0.10$

NHS3, National health seizure severity scale; QOL, Quality of life; CBCL, Child behaviour check list

Cognition, behaviour, mood and QOL and their association to seizure frequency and severity

Only two children improved in cognitive functioning. Behavioural changes did not show any significant improvement (Table 3). However, there seemed to be an improvement over time. A longer follow up might show additional improvement. The behaviour score was over the cut off score for manifest behaviour problems in 11/15 children. Seven of these improved. The four children with scores of manifest behaviour problems did not improve. Our results suggest an improvement in mood and some anti depressant effect. 80% of the children had an improvement in QOL (Table 3). This effect did not seem to be related to the anti seizure effects. Two children with improved QOL had increased seizure frequency and one of the three children with a worsening in QOL had unchanged seizure frequency. There seems to be a better correlation between improvement in QOL, mood and seizure severity. Of the 12 children with improvement in QOL, 11 also improved in mood and seizure severity.

Comments: Although caution must be taken when expressing absence of differences in a small group, we cannot find an association between anti seizure effect and improvement in QOL and behaviour [41, 75], not even when comparing between subgroups based on seizure reduction. However there seems to be a correlation between improvement in QOL, mood and seizure severity. Our results suggest an improvement in mood and some antidepressant effect. Studies in adults show a marked antidepressant effect in patients suffering from major depression [84]. No child had scores below the cut off for manifest depression at initiation of VNS in our study. Significant changes in depression parameters might be difficult to determine in patients not suffering from depression. We did not see any difference in cognitive functioning and there is a possibility that VNS does not affect cognitive functioning. The two children that improved in their IQ had the highest baseline IQ. This support previous findings of VNS on epileptiform activity that the treatment effect is related to the severity of the mental handicap with a better anti-epileptic effect in children with less severe impairment [6, 61, 75].

Interictal epileptiform discharges and electrographic seizures

In 14 children the epileptiform activity consisted of focal or multi-focal spike or sharp-wave complexes. One child had generalized spike-and-slow-waves. In eight children the epileptiform activity was infrequent and in three of these the epileptiform activity was sparse and appeared as solitary discharges. In seven children it was frequent. In two children more than 85% of non REM sleep consisted of continuous spike-wave discharges (CSWS).

After nine months of VNS-treatment the total number of epileptiform discharges was significantly reduced ($p=0,03$ in the 13 children without CSWS and $p=0,04$ in all 15 children).

When considering the four activity stages separately, there was a tendency towards reduction in all stages, significantly so in REM sleep ($p=0,03$) and slow wave sleep ($p=0,02$) in the 13 children without CSWS (Table 4). The total number of electrographic seizures was significantly reduced in the 24 hours EEG monitoring at both three and nine months ($p=0,03$, $0,05$) in the 13 children without CSWS. There was a significant concordance in direction of changes in IEDs and electrographic seizures at nine months in the 12 children with electrographic seizures ($p=0,04$). Three children did not have any electrographic seizures and could not contribute to the analysis.

Table 4 Changes in interictal epileptiform activity after 3 and 9 months of VNS-treatment in 15 children (bottom) and 13 children without CSWS (top)

Activity stage	Before initiation (baseline)	3 months after initiation	9 months after initiation
	Median (range)	Median (range) / p-value	Median (range) / p-value
wake	50.5 (0-2115)	49 (0-1999) / 0.64	39 (0-2182) / 0.67
stage 2	515 (0-3839)	189 (2-4827) / 0.17	463 (3-3330) / 0.3
REM	95 (1-2445)	75 (0-2216) / 0.08	46 (0-1688) / 0.03
sws	550 (0-3176)	209 (3-2174) / 0.10	155 (2-1295) / 0.02
total	968 (2-8133)	636 (8-6795) / 0.15	636 (9.5-4802) / 0.03

Activity stage	Before initiation (baseline)	3 months after initiation	9 months after initiation
	Median (range)	Median (range) / p-value	Median (range) / p-value
wake	91 (0-2115)	87 (0-1999) / 0.68	44 (0-2182) / 0.79
stage 2	515 (0-3839)	189 (2-4827) / 0.17	463 (3-3330) / 0.3
REM	215 (1-2445)	79 (0-2216) / 0.16	68 (0-2034) / 0.08
sws	599 (0-5634)	264 (3-5678) / 0.08	269 (2-4819) / 0.008
total	989 (2-10430)	643 (8-12795) / 0.23	809 (9-11923) / 0.04

CSWS, continuous spike-wave discharges during slow sleep; REM, rapid eye movement sleep; stage 2, sleep stage 2; sws, slow wave sleep

Comments: Although efforts are made to control for known influencing factors the variability in epileptiform activity between different recordings is well known. A larger variability is seen with generalized discharges [20, 36, 63, 67]. In our study, the epileptiform activity consisted of focal or multi-focal spike or sharp-wave complexes in 14 children and only one child had generalized spike-and-slow-waves. We used long-term 24 hour recordings and monitoring at the same real time of day in artefact free parts, AED plasma concentrations were monitored and found unchanged. The recordings were ambulatory, with the children in their natural surroundings. We saw a gradual decrease in epileptiform discharges in all activity stages and especially in REM sleep and slow wave sleep. This trend became significant at nine months. The total number of electrographic seizures was significantly

reduced in the 24 hours EEG monitoring at both three and nine months ($p=0,03, 0,05$). There was a significant concordance in direction of changes in IEDs and electrographic seizures at nine months in the 12 children with electrographic seizures ($p=0,04$). This gradual decrease in epileptiform activity together with the persistence of the anticonvulsant effects could suggest that VNS effects on epileptic pathophysiological processes work on different functional levels and can induce long-term neuron-modulating effects.

Pilot study – Correlation between visual inspection and Persyst Spike Detector System

This showed a high correlation between the visual and automatic spike detector system ($r=0.99$). Wilcoxon's signed rank test showed a systematic difference ($p=0,04$). The difference was never more than 78 spikes/h, and in 50% never more than 14 spikes/h (quartiles 0 and 14). In five of 21 analysed recordings the scores were identical and in 12 the visual inspection scored higher and in four lower.

Comments: A common average montage was used and each solitary spike or sharp wave with peak amplitude at least twice the local background activity was marked. With these simple and strict criteria we saw a high correlation between the visual and automatic spike detector system ($r=0.99$). Proportionally the automated spike detection never underestimated the visual inspection by more than 25%. This suggests a low rate of false positives in the visual inspection and that the automated spike detection never overestimated changes in number of spikes. The results indicate that our automatic spike detection in Persyst spike detector system is a simple and reliable tool for quantifying IEDs in longer EEG recordings.

Side effects

No severe side effects were seen either from the surgical procedure or from the VNS. Transient coughing and hoarseness after increasing the current was reported in four children. Weight loss was reported in one adolescent and a non-transient pain in the neck that was so disabling that QOL, behaviour and mood scores were affected. The stimulator was withdrawn after the study was finished. One child complained of breath shortness that did not improve completely until the pulse width was reduced from 500 to 250 μ seconds after the study was finished.

Comments: The incidence, severity and impact of induced adverse effects determine tolerability. Our study supports earlier findings that VNS has a good tolerability and is considered to have no severe intolerable adverse effects.

Sleep structure, delta power and movement times and the association to clinical effects on seizure frequency, seizure severity and QOL

Our findings show a VNS induced improvement of sleep quality with increased slow wave sleep in duration ($p=0,03$) and percentage ($p=0,04$), a tendency to decrease in sleep fragmentation and a tendency to reduction in daytime sleep. There was concordance in direction of changes between enhanced slow wave sleep and QOL in nine of 15 children.

There was significant increase in delta power in sleep cycle two after nine months ($p=0,05$) but only a tendency towards increase in the first sleep cycle and in over all night delta power.

We used movement times (MTs) as a sign of arousal. MTs increased in particular during sleep stage two ($p=0,12$, $0,02$) and slow wave sleep ($p=0,06$, $0,03$) and in immediate association to the VN stimulation epochs ($p=0,001$). This arousal effect might be one of several antiepileptic mechanisms in VNS and seems to be of minor consequence for QOL. Eleven of 15 children had both enhanced MTs and QOL.

Comments: Our findings indicate that VNS counteracts known epilepsy related sleep abnormalities such as altered sleep organization, increased awakenings, decreased sleep efficiency with increased daytime sleep and fragmented sleep. Cortesi showed in a study on 89 children with idiopathic epilepsy that they had more sleep problems and decreased QOL than controls [24]. There was a tendency towards decrease in daytime sleep, although we did not use an objective polysomnographic measure as multiple sleep latency tests (MSLT). We could not prove any direct quantitative correlation between enhanced slow wave sleep and QOL. This may be due to the small number of children and the fact that increased slow wave sleep is only one of several contributing factors to improved QOL together with decreased epileptiform activity, seizure frequency and severity and mood regulating factors. Despite the increase in slow wave sleep, delta power did not increase. This might be due to the small number of children with severe epileptic encephalopathy and enhanced background delta during wake, even though the two children with CSWS were excluded and artefacts were carefully provided for. Slow wave sleep is classified as sleep stage three and four according to Rechtschaffen and Kales criteria [82] and includes both theta and delta frequencies. The enhancement of slow wave sleep might be produced by other mechanisms than that produced by sleep deprivation. From animal studies and functional studies on VNS we know that VNS has direct projections via the nucleus of the solitary tract and the PB to the non REM sleep promoting GABA mediated VLPO in hypothalamus [21, 43, 49, 62, 104].

Table 5 Sleep Parameters and Delta Power Before and After 3 and 9 Months of Vagus Nerve Stimulation (VNS)

	Before VNS-initiation	3 months after VNS-initiation	9 months after VNS-initiation
	Median (range)	Median (range) p-value	Median (range) p-value
TS(min)	587.5 (503-781.5)	585 (443.5-739) p=0.6	603.5 (474-771.5) p=0.5
TNS (min)	522 (437.5-609.5)	547.5 (443.5-701.6) p=0.3	548.5 (467-701.6) p=0.15
TDS (min)	69.5 (0-202)	22.5 (0-180) p=0.07	0 (0-216.5) p=0.16
Stage 1 (min)	0 (0-14)	0 (0-22) p=0.4	0 (0-7.5) p=0.03
Stage 1 (% TNS)	0 (0-2.6)	0 (0-3.8) p=0.4	0 (0-1.4) p=0.03
Stage 2 (min)	275.5 (99-395.4)	239.5 (75.5-361.4) p=0.2	260.5 (105-472.5) p=0.3
Stage 2 (% TNS)	54.8 (18-77.9)	44.4 (13.4-70.5) p=0.08	43.8 (18.4-80.1) p=0.08
Stage 3+4 (min)	146.5 (32.5-370.5)	144 (38-426.5) p=0.1	180.5 (24.5-486) p=0.03
Stage 3+4 (% TNS)	26.1 (6.8-62.5)	25.8 (8.2-75.7) p=0.1	35.8 (4.1-78.3) p=0.04
REM (min)	81.5 (21-299)	93.5 (25-287.5) p=0.4	97.5 (17.5-266) p=0.7
REM (% TNS)	14.6 (4-55.2)	17.7 (4.1-49.6) p=0.5	20.4 (2,9-50.9) p=0.9
Delta Power night	120253 (9248 - 852468)	113607 (12823 - 140750) p=0.81	135321 (21251 - 616542) p=0.31
Delta Power sleep cycle I	12016 (180 - 85263)	5811 (365 - 63934) p=0.55	13222 (501 - 37498) p=0.65
Delta Power sleep cycle II	4697 (84 - 30321)	1400 (183 - 176100) p=0.5	7306 (643 - 1242687) p=0.05
MT (n/h TNS)	2.98 (0-12.71)	4.57 (0-9.82) p=0.09	4.52 (1.65-11.60) p=0.009
Stage shifts (n)	31 (11-68)	33 (17-58) p=0.75	25 (15-65) p=0.26
Sleep latency (min)	0 (0-15.5)	0 (0-26) p=0.57	0 (0-7.5) p=0.04

REM, Rapid eye movement sleep; Sleep latency, Time from lights-off to the first occurrence of stage 2; Stage 1/2/3+4, Sleep stage 1/2/3+4; TDS, Total daytime sleep; TNS, Total night sleep; TS, Total sleep

Immediate effects of VNS on interictal epileptiform discharges and spectral power

The 24 hour ambulatory EEG monitorings were also used to study immediate effects of VNS on IEDs and EEG spectral power. The findings lend no support to earlier studies suggesting immediate VNS related changes in IEDs. There were no immediate VNS related changes in EEG spectral power, confirming earlier findings from Salinsky and Burchiel. These findings indicate that the effects of VNS on seizures and total amount of IEDs cannot be explained by an immediate effect on arousal.

Comments: The expected arousal effects with decreased delta power in slow wave sleep and alpha power in wake immediately associated with the VNS was not seen. The absence of VN stimulation related findings support our long-term findings with gradual decrease in epileptiform activity and persistence of the anticonvulsant effects through out the nine months of follow-up. This could suggest that VNS effects on epileptic pathophysiological processes work on different functional levels and can induce long-term neuron-modulating effects as well as mood and sleep modifying effects.

KETOGENIC DIET

Sleep structure and clinical effects on seizure frequency, seizure severity, attentional behaviour and QOL and their correlation

KD decreases sleep ($p=0.05$) and total night sleep ($p=0.006$) and improves sleep quality and in particular increases REM sleep ($p=0.01$), in children with therapy resistant epilepsy. We also see an improvement in seizure frequency ($p=0.001$), seizure severity ($p<0.001$), attentional behaviour ($p=0.006$) and QOL ($p<0.001$) and a significant correlation between increased REM sleep and QOL at three months (Spearman $r= 0.6$, $p=0.01$). Eleven children continued with the KD and were also evaluated after 12 months. They showed a significant decrease in daytime sleep ($p=0.01$) and a further increase in REM sleep ($p=0.06$) (Table 6 and 7).

Eight children (44%) showed 90% or more reduction in seizure frequency, four (22%) became seizure free, four (22%) had a 50-90% seizure reduction, five (28%) less than 50% seizure reduction and one (6%) increased in seizure frequency. Eleven children (61%) continued with the diet. They were also evaluated after 12 months. They had a significant reduction in seizure frequency ($p=0.003$). Four (36%) had a 90% or more reduction of seizures, two (18%) were seizure free, four (36%) had a 50-90% seizure reduction and three (27%) less than 50% seizure reduction.

Comments: Initially, total sleep, total night sleep and daytime sleep were pathologically increased. REM sleep was decreased and sleep stage two and the number of sleep stage shifts were increased. The increase in REM sleep seems to be a normalization of the initially pathologically decreased duration and percentage of REM sleep. The decreased total sleep, total night sleep and daytime sleep seen in our study, are probably due to the improved sleep structure and sleep quality including increased REM sleep, decreased sleep stage two and preserved slow wave sleep, following KD. We infer that the increased REM sleep is an important marker for improved sleep quality. This was significantly correlated to the improved QOL. REM sleep is well documented to be associated with marked reduction, sometimes total absence of seizures and IEDs [94]. The neural generators of asynchronous neuronal discharge reduce electrographic seizure propagation during REM sleep. Together with other presumed antiepileptic effects of KD such as increased cerebral energy reserves, decreased ictal excitability, decreased rate of glutamate transamination to aspartate, enhancement in the rate of glutamate decarboxylation to GABA, the caloric restriction and direct anticonvulsant action of ketone bodies, polyunsaturated fatty acids, norepinephrine, galanine and neuropeptide Y (NPY), the normalization of REM sleep seems to be an important antiepileptic factor.

Table 6 and 7 Effects on sleep parameters, clinical seizures, seizure severity, quality of life, behaviour, attention and beta hydroxybutyrate initially and after 3 months of ketogenic diet

18 pat	Before KD Median (range)	After 3 months of KD Median (range) / p
TS (min)	675,75 (492,5 - 924)	589,25 (321,5 - 776) / 0,05
TNS (min)	612,10 (346,5 - 821)	546,55 (169 - 683) / 0,006
TDS (min)	53,75 (0 - 169,5)	53,75 (0 - 250) / 0,67
Stage 1 (min)	0 (0 - 8,5)	0,75 (0 - 5,5) / 0,48
Stage 1 (%TNS)	0 (0 - 1,4)	0,15 (0 - 1,6) / 0,38
Stage 2 (min)	195,25 (49 - 497)	141,75 (20 - 346) / 0,002
Stage 2 (%TNS)	36,3 (7,9 - 84,2)	26,5 (3,8 - 66) / 0,004
Stage 3+4 (min)	274,25 (27 - 613)	278 (25 - 463,5) / 0,5
Stage 3+4 (%TNS)	47,05 (4,6 - 77,9)	53,8 (7,5 - 82,7) / 0,29
REM (min)	86,5 (17,5 - 189,5)	97 (42 - 197,5) / 0,23
REM (%TNS)	14,15 (3,5 - 28,20)	19,55 (8 - 37,6) / 0,01
Stage shifts (n)	33 (12 - 44)	28 (16-44) / 0,59
Sleep latency (min)	0,5 (0 - 2)	0,05 (0 - 0,5) / 0,06
Clinical seizures	75,3 (1 - 21604)	15,8 (0 - 900) / 0,001
NHS3	12,5 (3 - 31)	6 (1 - 19) / <0,001
QOL	10 (10 - 10)	14 (10 - 18) / 0,001
CBCL	40 (13 - 19)	38 (6 - 73) / 0,08
PK	28 (7 - 21)	17 (3 - 35) / 0,006
Beta hydroxybutyrate	1 (0,1-3,2)	4,2 (2,6-7,7) / 0,003

11 pat	Before KD Median (range)	After 3 months of KD Median (range) / p	After 12 months of KD Median (range) / p
TS (min)	657 (492,5 - 924)	588,5 (321,5 - 766) / 0,08	573 (342 - 708,4) / 0,09
TNS (min)	600,40 (492 - 821)	546,55 (169 - 683) / 0,04	573 (342 - 708,4) / 0,5
TDS (min)	62,5 (0 - 118,5)	53,75 (0 - 250) / 0,58	0 (0 - 36) / 0,01
Stage 1 (min)	0 (0 - 8,5)	1 (0 - 2) / 1	0 (0 - 9) / 0,9
Stage 1 (% TNS)	0 (0 - 1,4)	0,2 (0 - 0,4) / 0,86	0 (0 - 1,3) / 0,83
Stage 2 (min)	188,5 (120 - 497)	141,75 (20 - 346) / 0,05	158 (70,9 - 388,4) / 0,1
Stage 2 (% TNS)	37,1 (14,7 - 84,2)	26,5 (3,8 - 66) / 0,05	30,1 (13,8 - 54,8) / 0,2
Stage 3+4 (min)	294 (27 - 613,5)	278 (25 - 463,5) / 0,37	215 (155 - 350,5) / 0,4
Stage 3+4 (% TNS)	54,1 (4,6 - 74,8)	53,8 (7,5 - 82,7) / 0,8	39,6 (21,9 - 67) / 0,5
REM min	69,5 (17,5 - 117)	97 (42 - 197,5) / 0,18	116 (44 - 194) / 0,04
REM %	11,2 (3,5 - 23,9)	19,55 (8 - 37,6) / 0,11	20,2 (9,9 - 36,9) / 0,06
Stage shifts (n)	28 (12 - 42)	28 (16 - 44) / 0,76	37 (24 - 50) / 0,3
Sleep latency (min)	0,5 (0 - 2)	0,1 (0 - 0,5) / 0,13	0 (0 - 116,5) / 0,2
Clinical seizures	122,6 (58 - 21604)	22 (0 - 900) / 0,002	49,6 (0 - 180) / 0,003
NHS3	12 (3 - 31)	5 (1 - 11) / 0,005	5 (1 - 14) / 0,005
QOL	10 (10 - 10)	15 (12 - 16,5) / 0,003	16 (12 - 20) / 0,005
CBCL	39 (13 - 61)	36 (6 - 67) / 0,18	34,5 (10 - 66) / 0,54
PK	27 (7 - 36)	17 (3 - 28) / 0,03	15 (0 - 38) / 0,08
Beta hydroxybutyrate	1 (0,1-3,2)	4,2 (2,6-7,7) / 0,003	5,2 (2,7-7,2) / 0,003

KD, Ketogenic diet; TS, Total sleep; TNS, Total night sleep; TDS, Total daytime sleep; Stage 1,2,3+4, Sleep stage 1,2,3+4; REM, Rapid eye movement; NHS3, National health seizure severity scale; QOL, Quality of life; CBCL, Child behaviour checklist; PK, Ponsford and Kinsella's rating scale of attentional behaviour

Side effects

One child discontinued the diet because of increased ataxia and lethargy. Three children had a mild increase in liver enzymes and two had a loss of hair in combination with Sodium valproate. One boy with mental retardation and autism had persistent acidosis and increased

outbursts of passion in combination with Sulthiame. There was a significantly increased carotid artery stiffness and although not significant changes in lipid and lipoprotein profile.

Comments: Adverse events in KD approach 10 %. Short-term side effects include hypoglycaemia, dehydration, vomiting, diarrhoea, lethargy and anorexia. Long-term side effects have not been thoroughly reported and include hyperlipidemia and or hypercholesterolemia, renal calculi, hyperuricemia, persistent acidosis, osteoporosis with hypocalcemia, neutrophilic dysfunction and recurrent infections, carnitine deficiency, hypo proteinemia and growth failure. Our study shows that a thoroughly monitoring and supplementation of vitamins and minerals can prevent and avoid most side effects. More data is needed to tell if these atherogenic changes in artery functioning stand for a correlation between atherosclerosis and KD.

GENERAL DISCUSSION

Today we know that therapy resistant epilepsy can be a progressive disease with cognitive and behavioural deficits. Both the occurrence of seizure and the interictal epileptiform discharges per se and the cerebral dysfunction and pathology underlying the liability to epilepsy may contribute to this. Subclinical interictal epileptiform discharges, causing transitory cognitive impairment, have become increasingly recognized and are probably one explanation to the progressivity in this disease [9, 14, 15]. The importance of accurate and fast interventions to treat, and in an increasing part of the patients via epilepsy surgery stop the seizures and IEDs, has become clear. Epilepsy surgery programs and other methods of treatment besides the anti epileptic drugs have developed during the last years. When antiepileptic drugs fail and epilepsy surgery is found unfeasible or ineffective, there remains a group of at least 25% in children with epilepsy in whom seizure control cannot be achieved. VNS and KD are two well-established methods of treatment in therapy resistant epilepsy. Still very little is known about the mechanisms of action of antiepileptic effects and other positive or negative side effects.

The core of this work was a prospective longitudinal study, in which the children were their own controls and compared initially and after three and nine months of VNS-treatment (three and 12 months of KD-treatment). These children have therapy resistant epilepsy with variable additional severe mental and motor impairments. Assessments that allow for different motor- visual- communication- behavioural- and cognitive impairments and the epilepsy syndrome per se are difficult to perform. Every child is unique in his own handicap-profile despite similar epilepsy syndrome. A matched control group had been preferable if there had been a larger amount of children, but there was not. For this reason we suggested that the children should be their own controls. A probable placebo effect is difficult to estimate and a randomized cross-over study could have been an alternative. Because of the possibility of long-term VNS effects and difficulties in choosing an accurate washout-period we decided that the children should be their own controls.

The general aim of this thesis was to evaluate effects of VNS on epileptiform activity, delta power and sleep characteristics and to correlate these to different clinical aspects in children with therapy resistant epilepsy. Sleep characteristics and clinical correlations were also evaluated in KD.

The findings in this thesis showed good antiepileptic effects of VNS (paper I, II). The improvement in clinical seizures is in accordance with earlier reports of a better and more rapid response in children compared with adults [41, 68, 75, 103, 108]. The tendency to reduction of IEDs in all activity stages, significantly so in REM sleep and slow wave sleep at

both three and nine months and the concordant reduction in electrographic seizures indicate an effect on both the generation and the spread of IEDs and that VNS affects epileptic pathophysiological processes. There were no concordant changes in clinical seizures and IEDs. One explanation could be that the parents' seizure frequency reports might be uncertain measures with a high rate of missed subtle seizures and undetected seizures during night. Today there is evidence that IEDs without clinical seizures may give rise to cognitive disturbances and affect short-time memory, perception and learning in children with epilepsy. Adequate assessments, in different activity stages such as the automatic spike detection described in paper II will probably become more important.

The improvement of QOL in our study is confirmed in earlier studies [28, 78, 108, 112]. In addition, we found, although not significant, a tendency of improvement in mood and behaviour. Results of the present study agree with other assessments on VNS that the antiepileptic effects do not correlate to clinical effects on QOL, mood and behaviour [25, 76]. On the other hand seizure severity improved significantly after VNS and showed a good concordance with QOL and mood. Seizure severity consequently might be an important parameter of effect in this group of children with therapy resistant epilepsy and cognitive impairment where seizure freedom is unexpected. In our study seizure severity showed a better concordance with QOL than clinical seizures, electrographic seizures and IEDs.

Cognitive functioning has an important impact on behaviour and it is important to find accurate assessments to be able to learn and understand the needs of this group of children with therapy resistant epilepsy and cognitive impairment. We did not see any differences in cognitive functioning before and after VNS. There is a possibility that VNS does not affect cognitive functioning. The two children that improved their IQ had the highest baseline IQ. In the 13 children without any changes in cognitive functioning four of the children had severe mental retardation with IQ below 30 and nine children had severe to moderate mental retardation. This support previous findings of VNS on epileptiform activity that the treatment effect is related to the severity of the mental handicap with a better anti-epileptic effect in children with less severe impairment [6, 61, 75].

In the third paper (paper III) we showed that VNS counteracts known adverse effects of epilepsy on sleep and increases slow wave sleep. Saper described a VNS induced stabilization of the reciprocal relationship between GABA mediated non REM sleep promoting hypothalamic VLPO activation and monoaminergic influence from LC and DR with slow wave sleep promoting, mood stabilizing and antiepileptic effects [86, 87]. Besides these plausible long-term modulating effects our sleep-studies show a VNS related arousal like effect that could be related to the antiepileptic mechanisms of VNS and does not seem to affect QOL [66]. Despite the arousal like effect of MTs no immediate effects on IEDs and

spectral power were seen (paper V). Quantitative techniques such as coherence analysis or nonlinear dynamic analysis of EEG have not been applied in the current study, and may provide evidence for more subtle changes in cortical dynamics during VNS [59, 72].

In paper four (paper IV), KD induced a significant decrease in total sleep and total night sleep, and at 12 months a decrease in total daytime sleep. Slow wave sleep was preserved, sleep stage two decreased and REM sleep was increased. Seizure frequency, seizure severity and QOL were significantly improved at three and twelve months. Attentional behaviour was also improved, significantly so at three months and there was a significant correlation between the increased REM sleep and improvement in QOL.

The sleep changes in KD differ from the sleep changes in VNS. We see a normalization of abnormal sleep patterns in most of the children with KD. The initially, pathologically increased total sleep, total night sleep and total daytime sleep decrease and the decreased REM sleep is normalized. In VNS we see a stabilization of total sleep with an increase of total night sleep in favour of a decreased total daytime sleep and an increase in slow wave sleep and REM sleep in favour of a decreased sleep stage two. Stage shifts and sleep latency are decreased towards normal. The two patient groups are compared in Table 8. In both KD and VNS the sleep changes develop gradually and seem to be long term modulating effects and as Saper indicated one could speculate that VNS, via the nucleus of the solitary tract, stabilizes the switch between VLPO promoted GABA-mediated slow wave sleep and LC and DR promoted norepinephrine- and serotonin- mediated wake, mood and antiepileptic effects [13, 49, 51, 62, 86, 90]. KD mimics starvation and the high fat intake decreases leptin and insulin levels and subsequently increases the expression of galanin and NPY. VLPO contains subregions that are specialized for the control of REM versus nonREM sleep. One could speculate that besides the anticonvulsant effects, the increase or normalization in REM sleep, of KD, is induced by changes in GABAergic and galaninergic functioning (Figure 5).

Table 8 Sleep changes in the VNS and KD group

	VNS	KD
Patients (n)	15	18
Age (y)	11 (4-17)	7,5 (2-15)
epilepsy onset (y)	3 (0,3-12)	0,7 (0-6)
partial epilepsy	9/15	8/18
AED	unchanged	unchanged
epilepsy surgery	4/15	1/18
Sleep		
TS	⇒	↓
TNS	(↑)	↓
TDS	↓	↓
sleep stage two	↓	↓
slow wave sleep	↑	↓
REM sleep	↑	↑
sleep stage shifts	↓	↑
sleep latency	↓	⇒
Comments	Stabilization of sleep	Normalization of sleep

AED, anti epileptic drug; KD, ketogenic diet; REM, rapid eye movement; TS, total sleep; TNS, total night sleep; TDS, total daytime sleep; VNS, vagus nerve stimulation

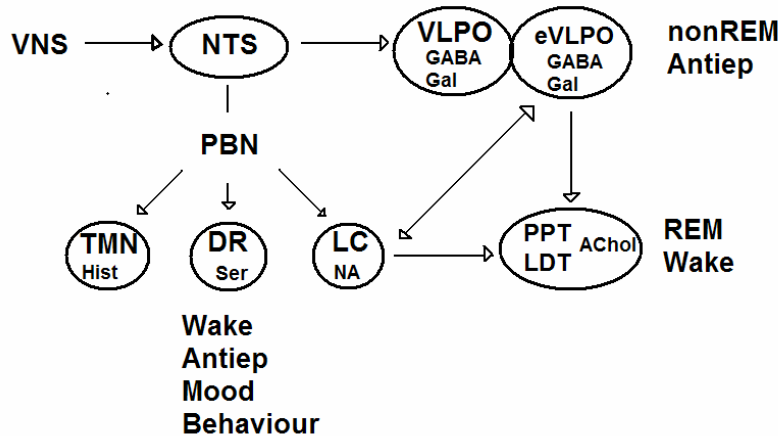

Figure 8. VNS induces GABAergic projection to the sleep and REM promoting ventrolateral preoptic nucleus (VLPO) and promotes wakefulness via the ascending arousal system. This includes monoaminergic cell-groups in the dorsal raphe nuclei (DR) and locus coeruleus (LC), histaminergic cell-groups in tuberomammillary nucleus (TMN), the cholinergic cell-groups in the laterodorsal and pedunculopontine tegmental nuclei (LDT, PPT). Via the nucleus of the solitary tract (NTS), VNS could stabilize the switch between VLPO promoted GABA-mediated slow wave sleep and LC and DR promoted norepinephrine- and serotonin- mediated wake, mood and antiepileptic effects. VLPO withhold sub-regions that are specialized for the control of REM versus nonREM sleep via LC, LDT and PPT. Since VLPO contains GABA and galanin (Gal), one could speculate that besides the anticonvulsant effects, the increase or normalization in REM sleep, of KD, is induced by changes in GABAergic and galaninergic functioning.

Future aspects

We have shown that KD improves sleep quality and in particular increases and normalizes REM sleep. We also see improvements in clinical parameters and a correlation between increased REM sleep and QOL. Today we know that cognitive and behavioural deficits in children with therapy resistant epilepsy might be related to subclinical interictal epileptiform discharges. We are planning to further investigate epileptiform activity, electrographic seizures and IEDs in different activity stages and to investigate cognitive changes in KD and correlate them to the changes in epileptiform activity. We also plan to further investigate hormonal and growth changes in ketogenic diet.

In our study we could see increased carotid artery stiffness, a subclinical marker of early atherosclerosis, although no significant changes in lipid and lipoprotein profile were observed (unpublished data). The use and popularity of KD is increasing rapidly although the mechanisms of action are unclear and further evaluation of effects and side effects is essential. Our findings together with other clinical studies have raised the hypothesis that KD might accelerate atherosclerosis. Inflammatory and lipid changes might underlie the putative atherogenic influences. KD might also increase the susceptibility to respiratory infection. The latter has in recent years been suggestive to additively interact with conventional cardiovascular risk factors in the development of atherosclerosis. In a mice study we plan to investigate eventual adverse influence of KD on systemic inflammation and lipid and lipoprotein profile and to study whether KD could promote arterial endothelial dysfunction and atherosclerotic lesions. We also plan to study eventual synergistic interaction between infection and KD in the development of endothelial dysfunction and atherosclerosis.

Despite the arousal like effect of MTs no immediate effects on IEDs and spectral power were seen. Quantitative techniques such as coherence analysis or nonlinear dynamic analysis of EEG have not been applied in the current study, and may provide evidence for more subtle changes in cortical dynamics during VNS.

CONCLUSIONS

- VNS is associated with a good antiepileptic effect, improvement in seizure severity and QOL and an improvement in behaviour over time. Therefore VNS can be recommended as a palliative treatment when epilepsy surgery is not eligible in children with therapy resistant epilepsy. This VNS antiseizure effect is not correlated to clinical effects on QOL, mood and behaviour.
- VNS is associated with reduction in interictal epileptiform discharges, especially in REM sleep and slow wave sleep and a reduction in the number of electrographic seizures. The effects on interictal epileptiform discharges as well as on seizures indicate that VNS affects the epileptic pathophysiological process on different functional levels.
- VNS increases slow wave sleep and counteracts known adverse effects of epilepsy on sleep. This possibly contributes to the improvement in wellbeing of VNS. VNS also increases movement times. This arousal effect seems to be of minor importance for QOL and could possibly be related to the antiepileptic mechanisms of VNS.
- KD decreases sleep and improves sleep quality and in particular increases REM sleep. KD also improves seizure frequency, seizure severity, attentional behaviour and QOL and there is a correlation between increased REM sleep and QOL. The increased REM sleep seems to be a normalization of a pathologically reduced REM sleep.
- The twenty-four hour ambulatory EEG monitorings were used to study immediate effects of VNS on interictal epileptiform discharges and EEG spectral power. The findings lend no support to earlier studies suggesting immediate VNS related changes in interictal epileptiform discharges. These findings indicate that the effects of VNS on seizures and interictal epileptiform discharges cannot be explained by an immediate effect on arousal. There were no immediate VNS related changes in EEG spectral power. These findings confirm earlier findings.

SUMMARY IN SWEDISH

SAMMANFATTNING PÅ SVENSKA

De flesta barn som insjuknar i epilepsi tillfrisknar eller blir anfallsfria med hjälp av antiepileptisk medicin. Hos drygt en fjärde del av barnen blir epilepsin svårbehandlad och anfallskontroll är svår att uppnå. Dessa barn ska i första hand erbjudas möjlighet till epilepsikirurgisk utredning och behandling. När epilepsikirurgisk behandling inte är möjlig att utföra eller inte gett förväntat resultat finns idag, förutom nya anti-epileptiska mediciner Vagus nerv stimulering och Ketogen kost.

Vagus nerv stimulering är en relativt ny behandlingmetod. En utifrån programmerbar generator levererar elektriska impulser via vagus nerven i syfte att reducera och lindra epileptiska anfall. Vagus nerven står i direkt förbindelse med områden i hjärnan som har betydelse för epilepsi utveckling och anfallsgenerering samt reglering av stämningsläge och sömn. Kost som behandling vid epilepsi är betydligt äldre, och finns beskrivet redan i bibeln. Raphaels målning the Transfiguration of God, är hämtad från Marcus evangeliet, och beskriver bl a hur Jesus botar ett epileptiskt anfall med fasta och böner. Ketogen kost är en fettrik, kolhydrat- och protein- fattig kost som utvecklades redan på 1920-talet till en behandlingsmetod som skulle ersätta fasta.

Målet med denna avhandling var att utvärdera effekter av vagus nerv stimulering på epileptisk aktivitet, elektrisk bakgrunds aktivitet och sömn samt att korrelera dessa med kliniska effekter på anfallsfrekvens, anfallsstyrka, beteende, stämningsläge, livskvalitet och kognition hos barn med svårbehandlad epilepsi, där epilepsikirurgisk behandling inte varit möjlig eller inte givit förväntad effekt. Utvärdering av effekt på sömn och korrelering med kliniska effekter gjordes även på ketogen kost behandling. Initialt och efter tre och nio månader (efter tre och tolv månader vid ketogen kost) undersöktes barnen med ambulatoriskt EEG under 24 timmar för detektion av epileptisk aktivitet och analys av sömn. Vidare undersöktes barnens kognitiva förmåga och föräldrarna fyllde i formulär avseende anfallsfrekvens, anfallsstyrka, beteende, stämningsläge och livskvalitet.

I den första artikeln visar vi att vagus nerv stimulering har god effekt både på anfallsfrekvens, anfallsstyrka och livskvalitet och att det finns en positiv effekt på beteende, stämningsläge och depressions parametrar som ökar med tiden. Effekten på anfallsstyrka och livskvalitet och den positiva effekten på beteende, stämningsläge och depressionsparametrar var inte relaterad till minskningen av epileptiska anfall.

I den andra artikeln utvärderar vi epileptisk aktivitet. Vi visar att den epileptiska aktiviteten minskar generellt och i synnerhet under REM sömn och djupsömn. Även antalet elektrografiska anfall minskar och vi kan visa att det finns en konkordans mellan minskningen

av antalet elektrografiska anfall och den totala minskningen av epileptisk aktivitet. Denna effekt på såväl epileptisk aktivitet som på anfallsaktivitet indikerar att vagus nerv stimulering påverkar den epileptiska processen på olika nivåer, dels i form av en antiepileptisk arousal effekt och dels i form av en mer långverkande, neuron modulerande effekt. I en pilotstudie utvärderade vi en automatisk metod att detektera epileptisk aktivitet. Denna visade sig ha en mycket god korrelation med den manuella och användes därför för detektion av epileptisk aktivitet.

I den tredje artikeln analyseras effekterna på sömn vid vagus nerv stimulering. Våra fynd indikerar att vagus nerv stimulering motverkar kända negativa effekter av epilepsi och epileptisk aktivitet på sömn. Dessutom ser vi en stabilisering av sömnarkitekturen med en ökning av djupsömnen, vilket skulle kunna bidra till den förbättrade livskvaliteten som beskrivs. Vi kan också visa att vagus nerv stimulering har en arousal liknande effekt. Denna effekt förefaller inte påverka välbefinnandet negativt utan istället vara relaterad till den antiepileptiska effekten vid vagus nerv stimulering. Vagus nerven har direkta förbindelser med centrala områden i hjärnan med betydelse för sömnreglering och antiepileptisk arousal effekt. Trots att vi ser omedelbara vagus nerv stimulerings relaterade effekter på arousal ser vi inga omedelbara stimulerings relaterade effekter på epileptisk aktivitet eller elektrisk bakgrunds aktivitet, analyserad med frekvensanalys.

Vid ketogen kost behandling ser vi en minskning av sömnen och en förbättring av sömnkvaliteten framför allt i form av en ökad REM sömn. Vi ser också en signifikant förbättring av anfallsfrekvens, anfallsstyrka, livskvalitet och uppmärksamhet samt en korrelation mellan den ökade REM sömnen och förbättrade livskvaliteten. Den ökade REM sömnen förefaller vara en normalisering av en tidigare onormalt reducerad REM sömn.

Genom att studera och kartlägga de neurofysiologiska effekterna på epileptisk aktivitet, sömn, elektrisk bakgrunds aktivitet samt att utvärdera och korrelera dessa med kliniska effekter på anfallsfrekvens, anfallsstyrka, beteende, stämningsläge, livskvalitet och kognition är det möjligt att få mer information om verkningsmekanismerna inte bara bakom den antiepileptiska effekten utan också bakom positiva och negativa sidoeffekter. Detta skulle kunna ha betydelse för ökade möjligheter att individualisera den antiepileptiska behandlingen.

ACKNOWLEDGEMENTS

This work was carried out at the Divisions of Paediatrics and Neurophysiology, Lund University Hospital

I wish to express my warm and sincere thanks to all the children and parents who participated in the study. You have learned me so much. Without you we would not have achieved the results. I hope our results will contribute to a better understanding of these treatments.

I also wish to express my sincere gratitude to

Ingmar Rosén. You have been my excellent chief supervisor and co-author. You guided me through the field of research and shared your deep knowledge. Thank you for sharp and fruitful discussions and for always being there with your never failing and warm support and for being my mentor. It has been a privilege to learn from you and to work with you. I hope this is only the beginning of our collaboration.

Johan Lundgren. You have been my co-supervisor and co-author and nearest colleague. You initiated and made this project possible despite a tight situation at the clinic. Thank you for your encouragement and enthusiasm.

Gösta Blennow, my co-supervisor. You gave me the opportunity to work with you in the interesting field of child neurology and epileptology. Thank you for your support and sharp scientific discussions.

Karin Stjernqvist, my co-supervisor and co-author. Thank you for good expert knowledge in the complicated field of neuropsychological and behavioural assessments.

Lars-Göran Strömblad, neurosurgeon in the VNS-study and *Anita Enbuske*, co-ordinating nurse at the Department of Neurosurgery. Thank you for excellent collaboration.

Inger Nordlund, *Eva-Karin Olsson* and *Melinda Vysehrad* for your great ability in taking care of and investigating the children in the EEG-laboratory. I also thank you for your patience and flexibility, and for teaching me ambulatory EEG and Polysomnography.

Colleagues and staff at the Division of Clinical Neurophysiology for introducing me in the fascinating world of Neurophysiology, especially the world of spikes and waves and for creating a stimulating and enjoyable atmosphere. *Marianne Ors* and *Douglas Hägerström*, for friendship. A special thank you to *Gert Andersson*, the head of the clinic for giving me a quiet place to finish my thesis.

Sven Köhler, my co-author. I hope this is only the beginning of our stimulating collaboration.

Jonas Björk, for enjoyable collaboration and for sharing your wide knowledge about statistics.

Petter Jarbo, for excellent knowledge in everything that has to do with computers, especially computer-programming.

Gunnar Gunnarsson, for being a "Mac-freak", for your kindness and for always being there to help with everything that has to do with computers.

Katarina Dykes, Kajsa Lönn, Jenny Svensson and *Ulla Berg*, for excellent collaboration and neuropsychological examination of the children.

Eva Dehlin, Ingrid Tønning-Olsson, Anna-Karin Undrén, Christina Axelsson and *Lisa Sjökvist* in the epilepsy and ketogenic diet teams, for taking so good care of our patients and for fun and pleasant collaboration. I hope there will be much more of this. Eva, thank you for sharing your wide experience and for all your help and support in my struggle in becoming an epileptologist.

Colleagues at the Division of Paediatrics and the Neuropaediatric team for friendship and support – *Gösta Blennow, Johan Lundgren, Lena Westbom, Vivian Nordin, Ulrika Uddenfeldt, Christina Peetre, Ingrid Sjöberg, Kristina Thorngren-Jerneck*.

All staff and secretaries at the *ward 62 and 63*, for always being kind and helpful.

Colleagues at the *Swedish Epilepsy Society Group*, the *Section of Inborn Errors of Metabolism of the Swedish Paediatric Society* and the *Scandinavian White Matter Group* for friendship, support and important scientific discussions.

My friends outside the research world: *Råå-vännerna*, the *After-Eight-choir* and especially *Mia Edström* for reminding me about the real world.

My family: My parents *Siv and Torgil*, for your endless love and support and my brothers, *Olof and Finn with their families*, for support.

And most of all: *Göran, Oskar and Frej*, for all your love, patience and support, and for being such a good team and such wonderful boys.

The research presented in this thesis was supported financially by grants from the Linnéa and Josef Carlsson Foundation, the Margarethahemmet Foundation, the Stiftelsen Samariten Foundation, the Segerfalk Foundation and the Swedish Medical Research Council (#084), the Skane county council's research and development foundation.

REFERENCES

1. (2000) Physician's Manual for the Neurocybernetic Prosthesis (Ncp) System Pulse Generator Models 100 and 101. In: Cyberonics, Inc. Houston, TX
2. (1989) Proposal for Revised Classification of Epilepsies and Epileptic Syndromes. Commission on Classification and Terminology of the International League against Epilepsy. *Epilepsia* 30:389-399
3. (1981) Proposal for Revised Clinical and Electroencephalographic Classification of Epileptic Seizures. From the Commission on Classification and Terminology of the International League against Epilepsy. *Epilepsia* 22:489-501
4. Achenbach T (1991) Manual for the Child Behaviour Checklist/4-8 and 1991 Profile. University of Vermont, Department of Psychiatry, Vermont
5. Aldenkamp AP, Majoie HJ, Berfelo MW, Evers SM, Kessels AG, Renier WO, Wilmink J (2002) Long-Term Effects of 24-Month Treatment with Vagus Nerve Stimulation on Behaviour in Children with Lennox-Gastaut Syndrome. *Epilepsy Behav* 3:475-479
6. Aldenkamp AP, Van de Veerdonk SH, Majoie HJ, Berfelo MW, Evers SM, Kessels AG, Renier WO, Wilmink J (2001) Effects of 6 Months of Treatment with Vagus Nerve Stimulation on Behavior in Children with Lennox-Gastaut Syndrome in an Open Clinical and Nonrandomized Study. *Epilepsy Behav* 2:343-350
7. Andersson T, Solders G (1996) Neurofysiologiska Mätmedtoder. In: *Neurofysiologi. Liber*, pp 215-222
8. Arts N (ed) (2001) *Epilepsy through the Ages, an Anthology of Classic Writings on Epilepsy*. Van Zuiden communications B.V., Alphen aan den Rijn
9. Baillet LL, Turk WR (2000) The Impact of Childhood Epilepsy on Neurocognitive and Behavioral Performance: A Prospective Longitudinal Study. *Epilepsia* 41:426-431
10. Bailey P, Bremer F (1938) A Sensory Cortical Representation of the Vagus Nerve. *J Neurophysiol* 1:405-412
11. Bayley N (1993) Manual for Bayley Scales of Infant Development. TX: Psychological Coep, San Antonio
12. Bazil CW, Walczak TS (1997) Effects of Sleep and Sleep Stage on Epileptic and Nonepileptic Seizures. *Epilepsia* 38:56-62

13. Ben-Menachem E, Hamberger A, Hedner T, Hammond EJ, Uthman BM, Slater J, Treig T, Stefan H, Ramsay RE, Wernicke JF, et al. (1995) Effects of Vagus Nerve Stimulation on Amino Acids and Other Metabolites in the Csf of Patients with Partial Seizures. *Epilepsy Res* 20:221-227
14. Binnie CD (1993) Significance and Management of Transitory Cognitive Impairment Due to Subclinical Eeg Discharges in Children. *Brain Dev* 15:23-30
15. Bjornaes H, Stabell K, Henriksen O, Loyning Y (2001) The Effects of Refractory Epilepsy on Intellectual Functioning in Children and Adults. A Longitudinal Study. *Seizure* 10:250-259
16. Bjornaes H, Stabell KE, Henriksen O, Roste G, Diep LM (2002) Surgical Versus Medical Treatment for Severe Epilepsy: Consequences for Intellectual Functioning in Children and Adults. A Follow-up Study. *Seizure* 11:473-482
17. Boon P, Vonck K, De Reuck J, Caemaert J (2001) Vagus Nerve Stimulation for Refractory Epilepsy. *Seizure* 10:448-455
18. Borbely AA, Achermann P (1999) Sleep Homeostasis and Models of Sleep Regulation. *J Biol Rhythms* 14:557-568
19. Broughton R (1999) Polysomnography: Principles and Applications in Sleep and Arousal Disorders. In: Niedermeyer E, Silva FLd (eds) *Electroencephalography Basic Principles, Clinical Applications, and Related Fields*. Williams & Wilkins, Baltimore, pp 858-896
20. Camfield P, Gordon K, Camfield C, Tibbles J, Dooley J, Smith B (1995) Eeg Results Are Rarely the Same If Repeated within Six Months in Childhood Epilepsy. *Can J Neurol Sci* 22:297-300
21. Chae JH, Nahas Z, Lomarev M, Denslow S, Lorberbaum JP, Bohning DE, George MS (2003) A Review of Functional Neuroimaging Studies of Vagus Nerve Stimulation (Vns). *J Psychiatr Res* 37:443-455
22. Chase MH, Nakamura Y, Clemente CD, Sterman MB (1967) Afferent Vagal Stimulation: Neurographic Correlates of Induced Eeg Synchronization and Desynchronization. *Brain Res* 5:236-249
23. Cipolli C, Bolzani R, Tuozzi G (1998) Story-Like Organization of Dream Experience in Different Periods of Rem Sleep. *J Sleep Res* 7:13-19
24. Cortesi F, Giannotti F, Ottaviano S (1999) Sleep Problems and Daytime Behavior in Childhood Idiopathic Epilepsy. *Epilepsia* 40:1557-1565
25. Cramer JA (2001) Exploration of Changes in Health-Related Quality of Life after 3 Months of Vagus Nerve Stimulation. *Epilepsy Behav* 2:460-465

26. Davies S, Heyman I, Goodman R (2003) A Population Survey of Mental Health Problems in Children with Epilepsy. *Dev Med Child Neurol* 45:292-295
27. Dodrill CB, Arnett JL, Sommerville KW, Sussman NM (1993) Evaluation of the Effects of Vigabatrin on Cognitive Abilities and Quality of Life in Epilepsy. *Neurology* 43:2501-2507
28. Dodrill CB, Morris GL (2001) Effects of Vagal Nerve Stimulation on Cognition and Quality of Life in Epilepsy. *Epilepsy Behav* 2:46-53
29. Forsgren L, Beghi E, Oun A, Sillanpaa M (2005) The Epidemiology of Epilepsy in Europe - a Systematic Review. *Eur J Neurol* 12:245-253
30. Freeman J, Kelly M, Freeman J (1994) *The Epilepsy Diet Treatment: An Introduction to the Ketogenic Diet*. Demos, New York
31. Freeman JM, Vining EP, Pillas DJ, Pyzik PL, Casey JC, Kelly LM (1998) The Efficacy of the Ketogenic Diet-1998: A Prospective Evaluation of Intervention in 150 Children. *Pediatrics* 102:1358-1363
32. Freitag H, Tuxhorn I (2005) Cognitive Function in Preschool Children after Epilepsy Surgery: Rationale for Early Intervention. *Epilepsia* 46:561-567
33. Galli R, Limbruno U, Pizzanelli C, Giorgi FS, Lutzemberger L, Strata G, Pataleo L, Mariani M, Iudice A, Murri L (2003) Analysis of Rr Variability in Drug-Resistant Epilepsy Patients Chronically Treated with Vagus Nerve Stimulation. *Auton Neurosci* 107:52-59
34. Gillberg IC, Gillberg C (1989) Children with Preschool Minor Neurodevelopmental Disorders. Iv: Behaviour and School Achievement at Age 13. *Dev Med Child Neurol* 31:3-13
35. Goldensohn E (1997) Historical Perspectives. In: Engel J, Pedley T (eds) *Epilepsy, a Comprehensive Textbook*. Lippincott-Raven, Philadelphia, pp 15-39
36. Gotman J (1991) Relationships between Interictal Spiking and Seizures: Human and Experimental Evidence. *Can J Neurol Sci* 18:573-576
37. Gotman J, Marciani MG (1985) Electroencephalographic Spiking Activity, Drug Levels, and Seizure Occurrence in Epileptic Patients. *Ann Neurol* 17:597-603
38. Gotman J, Yves J (1997) Computer-Assisted Data Collection and Analysis. In: Engel JJ, Pedley T (eds) *Epilepsy: A Comprehensive Textbook*. Lippincott-Raven, Philadelphia, New York, pp 1029-1044

39. Guilleminault C (ed) (1987) *Sleep and Its Disorders in Children*. Raven Press, New York
40. Heck C, Helmers SL, DeGiorgio CM (2002) Vagus Nerve Stimulation Therapy, Epilepsy, and Device Parameters: Scientific Basis and Recommendations for Use. *Neurology* 59:S31-37
41. Helmers SL, Wheless JW, Frost M, Gates J, Levisohn P, Tardo C, Conry JA, Yalnizoglu D, Madsen JR (2001) Vagus Nerve Stimulation Therapy in Pediatric Patients with Refractory Epilepsy: Retrospective Study. *J Child Neurol* 16:843-848
42. Henry TR (2002) Therapeutic Mechanisms of Vagus Nerve Stimulation. *Neurology* 59:S3-14
43. Henry TR, Bakay RA, Votaw JR, Pennell PB, Epstein CM, Faber TL, Grafton ST, Hoffman JM (1998) Brain Blood Flow Alterations Induced by Therapeutic Vagus Nerve Stimulation in Partial Epilepsy: I. Acute Effects at High and Low Levels of Stimulation. *Epilepsia* 39:983-990
44. Hostetler WE, Doller HJ, Homan RW (1992) Assessment of a Computer Program to Detect Epileptiform Spikes. *Electroencephalogr Clin Neurophysiol* 83:1-11
45. Hughes J (1994) *Eeg in Clinical Practice*. Butterworth-Heinemann, Newton, MA
46. Hume KI, Van F, Watson A (1998) A Field Study of Age and Gender Differences in Habitual Adult Sleep. *J Sleep Res* 7:85-94
47. Ivarsson T, Lidberg A, Gillberg C (1994) The Birleson Depression Self-Rating Scale (Dsrs). Clinical Evaluation in an Adolescent Inpatient Population. *J Affect Disord* 32:115-125
48. Jouvet M (1998) Paradoxical Sleep as a Programming System. *J Sleep Res* 7 Suppl 1:1-5
49. Krahl SE, Clark KB, Smith DC, Browning RA (1998) Locus Coeruleus Lesions Suppress the Seizure-Attenuating Effects of Vagus Nerve Stimulation. *Epilepsia* 39:709-714
50. Krahl SE, Senanayake SS, Handforth A (2001) Destruction of Peripheral C-Fibers Does Not Alter Subsequent Vagus Nerve Stimulation-Induced Seizure Suppression in Rats. *Epilepsia* 42:586-589
51. Kumar P, Raju TR (2001) Seizure Susceptibility Decreases with Enhancement of Rapid Eye Movement Sleep. *Brain Res* 922:299-304

52. Kwan P, Brodie MJ (2000) Early Identification of Refractory Epilepsy. *N Engl J Med* 342:314-319
53. Kwan P, Brodie MJ (2000) Epilepsy after the First Drug Fails: Substitution or Add-On? *Seizure* 9:464-468
54. Lah S (2004) Neuropsychological Outcome Following Focal Cortical Removal for Intractable Epilepsy in Children. *Epilepsy Behav* 5:804-817
55. Lanska DJ (2002) J.L. Corning and Vagal Nerve Stimulation for Seizures in the 1880s. *Neurology* 58:452-459
56. Laporte N, Sebire G, Gillerot Y, Guerrini R, Ghariani S (2002) Cognitive Epilepsy: Adhd Related to Focal Eeg Discharges. *Pediatr Neurol* 27:307-311
57. Larsson B, Frisk M (1999) Social Competence and Emotional/Behaviour Problems in 6-16 Year-Old Swedish School Children. *Eur Child Adolesc Psychiatry* 8:24-33
58. Lefevre F, Aronson N (2000) Ketogenic Diet for the Treatment of Refractory Epilepsy in Children: A Systematic Review of Efficacy. *Pediatrics* 105:E46
59. Lehnertz K, Andrzejak RG, Arnhold J, Kreuz T, Mormann F, Rieke C, Widman And G, Elger CE (2001) Nonlinear Eeg Analysis in Epilepsy: Its Possible Use for Interictal Focus Localization, Seizure Anticipation, and Prevention. *J Clin Neurophysiol* 18:209-222
60. Lundgren J, Ekberg O, Olsson R (1998) Aspiration: A Potential Complication to Vagus Nerve Stimulation. *Epilepsia* 39:998-1000
61. Majoie HJ, Berfelo MW, Aldenkamp AP, Evers SM, Kessels AG, Renier WO (2001) Vagus Nerve Stimulation in Children with Therapy-Resistant Epilepsy Diagnosed as Lennox-Gastaut Syndrome: Clinical Results, Neuropsychological Effects, and Cost-Effectiveness. *J Clin Neurophysiol* 18:419-428
62. Marrosu F, Serra A, Maleci A, Puligheddu M, Biggio G, Piga M (2003) Correlation between Gaba(a) Receptor Density and Vagus Nerve Stimulation in Individuals with Drug-Resistant Partial Epilepsy. *Epilepsy Res* 55:59-70
63. Martins da Silva A, Aarts JH, Binnie CD, Laxminarayan R, Lopes da Silva FH, Meijer JW, Nagelkerke N (1984) The Circadian Distribution of Interictal Epileptiform Eeg Activity. *Electroencephalogr Clin Neurophysiol* 58:1-13
64. Marzec ML, Selwa LM, Malow BA (2005) Analysis of the First Night Effect and Sleep Parameters in Medically Refractory Epilepsy Patients. *Sleep Med* 6:277-280

65. Mendez M, Radtke RA (2001) Interactions between Sleep and Epilepsy. *J Clin Neurophysiol* 18:106-127
66. Miller JW, Gray BC, Turner GM, Bardgett ME (1993) An Ascending Seizure-Controlling Pathway in the Medial Brainstem and Thalamus. *Exp Neurol* 121:106-112
67. Mizrahi EM (1996) Avoiding the Pitfalls of Eeg Interpretation in Childhood Epilepsy. *Epilepsia* 37 Suppl 1:S41-51
68. Murphy JV (1999) Left Vagal Nerve Stimulation in Children with Medically Refractory Epilepsy. The Pediatric Vns Study Group. *J Pediatr* 134:563-566
69. Mykityn IJ, Sajkov D, Neill AM, McEvoy RD (1999) Portable Computerized Polysomnography in Attended and Unattended Settings. *Chest* 115:114-122
70. Niedermeyer E (1999) Sleep and Eeg. In: Niedermeyer E, Silva FLd (eds) *Electroencephalography Basic Principles, Clinical Applications, and Related Fields*. Williams & Wilkins, Baltimore, pp 174-215
71. Nordli DR, Jr., Kuroda MM, Carroll J, Koenigsberger DY, Hirsch LJ, Bruner HJ, Seidel WT, De Vivo DC (2001) Experience with the Ketogenic Diet in Infants. *Pediatrics* 108:129-133
72. Nunez P (1995) Nonlinear Phenomena and Chaos. In: Nunez P (ed) *Neocortical Dynamics and Human Eeg Rhythms* Oxford University Press, New York, Oxford, pp 417-474
73. O'Donoghue MF, Duncan JS, Sander JW (1996) The National Hospital Seizure Severity Scale: A Further Development of the Chalfont Seizure Severity Scale. *Epilepsia* 37:563-571
74. Ohayon MM, Carskadon MA, Guilleminault C, Vitiello MV (2004) Meta-Analysis of Quantitative Sleep Parameters from Childhood to Old Age in Healthy Individuals: Developing Normative Sleep Values across the Human Lifespan. *Sleep* 27:1255-1273
75. Parker AP, Polkey CE, Binnie CD, Madigan C, Ferrie CD, Robinson RO (1999) Vagal Nerve Stimulation in Epileptic Encephalopathies. *Pediatrics* 103:778-782
76. Patwardhan RV, Stong B, Bebin EM, Mathisen J, Grabb PA (2000) Efficacy of Vagal Nerve Stimulation in Children with Medically Refractory Epilepsy. *Neurosurgery* 47:1353-1357; discussion 1357-1358
77. Pedley T (1980) Interictal Epileptiform Discharges: Discriminating Characteristics and Clinical Correlations. *Am J EEG Technol* 20:101-119

78. Polkey CE (2003) Alternative Surgical Procedures to Help Drug-Resistant Epilepsy - a Review. *Epileptic Disord* 5:63-75
79. Ponsford J, Kinsella G (1991) The Use of a Rating Scale of Attentional Behaviour. *Neuropsychological Rehabilitation* 1:241-257
80. Pulsifer MB, Gordon JM, Brandt J, Vining EP, Freeman JM (2001) Effects of Ketogenic Diet on Development and Behavior: Preliminary Report of a Prospective Study. *Dev Med Child Neurol* 43:301-306
81. Rajna P, Lona C (1989) Sensory Stimulation for Inhibition of Epileptic Seizures. *Epilepsia* 30:168-174
82. Rechtschaffen A, Kales A (1968) A Manual of Standardized Terminology, Techniques and Scoring System for Sleep Stage of Human Subjects. In: Service WDPH (ed)US Government Printing Office (National Institutes of Health Publication No.204)
83. Ronen GM, Streiner DL, Rosenbaum P (2003) Health-Related Quality of Life in Children with Epilepsy: Development and Validation of Self-Report and Parent Proxy Measures. *Epilepsia* 44:598-612
84. Rush AJ, George MS, Sackeim HA, Marangell LB, Husain MM, Giller C, Nahas Z, Haines S, Simpson RK, Jr., Goodman R (2000) Vagus Nerve Stimulation (Vns) for Treatment-Resistant Depressions: A Multicenter Study. *Biol Psychiatry* 47:276-286
85. Rutecki P (1990) Anatomical, Physiological, and Theoretical Basis for the Antiepileptic Effect of Vagus Nerve Stimulation. *Epilepsia* 31 Suppl 2:S1-6
86. Saper CB, Chou TC, Scammell TE (2001) The Sleep Switch: Hypothalamic Control of Sleep and Wakefulness. *Trends Neurosci* 24:726-731
87. Saper CB, Scammell TE, Lu J (2005) Hypothalamic Regulation of Sleep and Circadian Rhythms. *Nature* 437:1257-1263
88. Schachter SC, Saper CB (1998) Vagus Nerve Stimulation. *Epilepsia* 39:677-686
89. Schwartzkroin PA (1999) Mechanisms Underlying the Anti-Epileptic Efficacy of the Ketogenic Diet. *Epilepsy Res* 37:171-180
90. Sherin JE, Elmquist JK, Torrealba F, Saper CB (1998) Innervation of Histaminergic Tuberomammillary Neurons by Gabaergic and Galaninergic Neurons in the Ventrolateral Preoptic Nucleus of the Rat. *J Neurosci* 18:4705-4721
91. Sherin JE, Shiromani PJ, McCarley RW, Saper CB (1996) Activation of Ventrolateral Preoptic Neurons During Sleep. *Science* 271:216-219

92. Shinnar S, Berg AT, O'Dell C, Newstein D, Moshe SL, Hauser WA (2000) Predictors of Multiple Seizures in a Cohort of Children Prospectively Followed from the Time of Their First Unprovoked Seizure. *Ann Neurol* 48:140-147
93. Shneerson J (2000) *Handbook of Sleep Medicine*. Blackwell Science Ltd, Cambridge
94. Shouse MN, Farber PR, Staba RJ (2000) Physiological Basis: How Nrem Sleep Components Can Promote and Rem Sleep Components Can Suppress Seizure Discharge Propagation. *Clin Neurophysiol* 111 Suppl 2:S9-S18
95. Smith ML, Elliott IM, Lach L (2002) Cognitive Skills in Children with Intractable Epilepsy: Comparison of Surgical and Nonsurgical Candidates. *Epilepsia* 43:631-637
96. Smith ML, Elliott IM, Lach L (2004) Cognitive, Psychosocial, and Family Function One Year after Pediatric Epilepsy Surgery. *Epilepsia* 45:650-660
97. Stafstrom CE, Rho JM (eds) (2004) *Epilepsy and the Ketogenic Diet*. Humana Press, Totowa
98. Steffenburg S, Gillberg C, Steffenburg U (1996) Psychiatric Disorders in Children and Adolescents with Mental Retardation and Active Epilepsy. *Arch Neurol* 53:904-912
99. Steffenburg U, Hagberg G, Viggedal G, Kyllerman M (1995) Active Epilepsy in Mentally Retarded Children. I. Prevalence and Additional Neuro-Impairments. *Acta Paediatr* 84:1147-1152
100. Terry R, Tarver WB, Zabara J (1990) An Implantable Neurocybernetic Prosthesis System. *Epilepsia* 31 Suppl 2:S33-37
101. Touchon J, Baldy-Moulinier M, Billiard M, Besset A, Cadilhac J (1991) Sleep Organization and Epilepsy. *Epilepsy Res Suppl* 2:73-81
102. Tromp SC, Weber JW, Aldenkamp AP, Arends J, vander Linden I, Diepman L (2003) Relative Influence of Epileptic Seizures and of Epilepsy Syndrome on Cognitive Function. *J Child Neurol* 18:407-412
103. Wakai S, Kotagal P (2001) Vagus Nerve Stimulation for Children and Adolescents with Intractable Epilepsies. *Pediatr Int* 43:61-65
104. Van Laere K, Vonck K, Boon P, Versijpt J, Dierckx R (2002) Perfusion Spect Changes after Acute and Chronic Vagus Nerve Stimulation in Relation to Prestimulus Condition and Long-Term Clinical Efficacy. *J Nucl Med* 43:733-744
105. Vasconcellos E, Wyllie E, Sullivan S, Stanford L, Bulacio J, Kotagal P, Bingaman W (2001) Mental Retardation in Pediatric Candidates for Epilepsy Surgery: The Role of Early Seizure Onset. *Epilepsia* 42:268-274

106. Wechsler D (1999) Wechsler Intelligence Scales for Children. Swedish Version. Psykologiförlaget AB, Stockholm
107. Wechsler D (1999) Wechsler Preschool and Primary Scale of Intelligence-Revised. Swedish Version. Psykologiförlaget AB, Stockholm
108. Wheless JW, Maggio V (2002) Vagus Nerve Stimulation Therapy in Patients Younger Than 18 Years. *Neurology* 59:S21-25
109. Wilson SB, Harner RN, Duffy FH, Tharp BR, Nuwer MR, Sperling MR (1996) Spike Detection. I. Correlation and Reliability of Human Experts. *Electroencephalogr Clin Neurophysiol* 98:186-198
110. Wilson SB, Turner CA, Emerson RG, Scheuer ML (1999) Spike Detection II: Automatic, Perception-Based Detection and Clustering. *Clin Neurophysiol* 110:404-411
111. Zabara J, Chaffee RB, Jr., Tansy MF (1972) Neuroinhibition in the Regulation of Emesis. *Space Life Sci* 3:282-292
112. Zamponi N, Rychlicki F, Cardinali C, Luchetti A, Trignani R, Ducati A (2002) Intermittent Vagal Nerve Stimulation in Paediatric Patients: 1-Year Follow-Up. *Childs Nerv Syst* 18:61-66
113. Zanchetti A, Wang SC, Moruzzi G (1952) The Effect of Vagal Afferent Stimulation on the Eeg Pattern of the Cat. *Electroencephalogr Clin Neurophysiol* 4:357-361