



# LUND UNIVERSITY

## Atomic spectroscopy with violet laser diodes

Gustafsson, U; Alnis, J; Svanberg, Sune

*Published in:*  
American Journal of Physics

*DOI:*  
[10.1119/1.19505](https://doi.org/10.1119/1.19505)

2000

[Link to publication](#)

*Citation for published version (APA):*  
Gustafsson, U., Alnis, J., & Svanberg, S. (2000). Atomic spectroscopy with violet laser diodes. *American Journal of Physics*, 68(7), 660-664. <https://doi.org/10.1119/1.19505>

*Total number of authors:*  
3

### General rights

Unless other specific re-use rights are stated the following general rights apply:  
Copyright and moral rights for the publications made accessible in the public portal are retained by the authors and/or other copyright owners and it is a condition of accessing publications that users recognise and abide by the legal requirements associated with these rights.

- Users may download and print one copy of any publication from the public portal for the purpose of private study or research.
- You may not further distribute the material or use it for any profit-making activity or commercial gain
- You may freely distribute the URL identifying the publication in the public portal

Read more about Creative commons licenses: <https://creativecommons.org/licenses/>

### Take down policy

If you believe that this document breaches copyright please contact us providing details, and we will remove access to the work immediately and investigate your claim.

LUND UNIVERSITY

PO Box 117  
221 00 Lund  
+46 46-222 00 00

# Atomic spectroscopy with violet laser diodes

U. Gustafsson, J. Alnis, and S. Svanberg

*Department of Physics, Lund Institute of Technology, P.O. Box 118, S-221 00 Lund, Sweden*

(Received 28 June 1999; accepted 27 October 1999)

Laser spectroscopy with laser diodes can now also be performed in the violet/blue spectral region. A 5 mW commercially available CW laser diode operating at 404 nm was used to perform spectroscopy on potassium atoms with signal detection in absorption as well as fluorescence when operating on a potassium vapor cell and with optogalvanic detection on a potassium hollow cathode lamp. The  $4s\ ^2S_{1/2}-5p\ ^2P_{3/2,1/2}$  transitions were observed at 404.5 and 404.8 nm, respectively. The laser diode was operated with a standard laser diode driver, and with or without an external cavity. The  $4s\ ^2S_{1/2}-4p\ ^2P_{1/2}$  transition at 770.1 nm was also observed with a different laser diode. Here, Doppler-free saturated-absorption signals were also observed, enabling the evaluation of the ground-state hyperfine splitting of about 460 MHz. The data recorded allows an experimental verification of the theory for Doppler broadening at two widely separated wavelengths. © 2000 American Association of Physics Teachers.

## I. INTRODUCTION

The development of narrow-band tunable lasers, in particular dye lasers, has allowed the emergence of powerful spectroscopic techniques for atomic and molecular spectroscopy.<sup>1,2</sup> The Doppler width of the transitions is normally of the order of 1 GHz and is much larger than the laser linewidth, allowing an easy study of the Doppler-broadened transitions. Using Doppler-free techniques, a resolution limited only by the natural radiative linewidth (typically a few MHz) can be obtained for narrow-band lasers. Much data on atomic structure including hyperfine splittings and isotopic shifts have been obtained through the years.

The development of single-mode near-IR (infrared) laser diodes made the techniques of laser spectroscopy accessible for student laboratories also. The most readily available experiment was to induce the  $5s\ ^2S_{1/2}-5p\ ^2P_{3/2,1/2}$  transitions in rubidium atoms using easily available AlGaAs semiconductor lasers at 780.2 and 794.7 nm, respectively. Such experiments using free-running diode lasers on an atomic beam were described by Camparo and Klimac.<sup>3</sup> At our university, a laboratory session on rubidium laser diode spectroscopy has been offered for all physics students since 1990. Doppler-broadened transitions in an atomic vapor cell are observed, and by back-reflecting the laser diode beam, Doppler-free saturation signals are also recorded. We recently helped implement such experiments on isotopically enriched cells of <sup>85</sup>Rb and <sup>87</sup>Rb at four African universities, in Dakar (Senegal), Khartoum (Sudan), Nairobi (Kenya), and Cape Coast (Ghana) (see, e.g., Ref. 4). Laser diode spectroscopy for teaching purposes has also been demonstrated for Cs (852.3 nm)<sup>5,6</sup> and Li (671.0 nm).<sup>7,8</sup> Here, an improved laser performance (extended tuning range and narrow linewidth) was achieved by employing an external cavity including a Littrow grating.

The purpose of the present paper is to bring to the attention of the reader the fact that diode laser spectroscopy can now be extended to the violet/blue spectral region, due to the recent remarkable progress in GaN semiconductor lasers at Nichia Corporation by Nakamura and collaborators.<sup>9,10</sup> Blue diode laser spectroscopy is illustrated with experiments on the second resonance lines  $4s\ ^2S_{1/2}-5p\ ^2P_{3/2,1/2}$  of potassium at 404.5 and 404.8 nm. For reference and comparison, the

near-IR potassium line  $4s\ ^2S_{1/2}-4p\ ^2P_{1/2}$  at 770.1 nm was induced with a different semiconductor laser. With the near-IR laser diode used it was not possible to observe the  $4s\ ^2S_{1/2}-4p\ ^2P_{3/2}$  line at 766.7 nm.

Natural potassium consists of two isotopes, <sup>39</sup>K (93%) and <sup>41</sup>K (7%), both with a nuclear spin of  $\frac{3}{2}$ . Because of the dominance of <sup>39</sup>K we only need to consider this isotope. The structures of the near-IR and blue lines are given in Fig. 1, where the hyperfine structure splittings are obtained from Ref. 11. We note that, because of the small magnetic moment of the <sup>39</sup>K nucleus, the hyperfine structure splittings are small. The ground-state splitting is 462 MHz; for <sup>41</sup>K it is even smaller, 254 MHz. Thus, the Doppler-broadened line is not expected to show any structure, while a saturated absorption spectrum should be dominated by two peaks separated by about 460 MHz and broadened by upper-state unresolved hyperfine structure. Because of the fact that the excited state hyperfine structure is small and in the present context non-resolvable, while the ground-state splitting produces sharp separated peaks, it could be argued that potassium is pedagogically better suited than Li, Rb, and Cs for a student laboratory session at a particular level of atomic physics knowledge.

It is not our intention to record and evaluate high-resolution atomic spectra in the present work. Instead we would like to emphasize the use of free-running laser diodes and laser diode use in a simple feedback cavity, to demonstrate, evaluate, and experimentally verify the theory for Doppler broadening while also drawing attention to the phenomenon of hyperfine structure.

## II. EXPERIMENTAL SETUP

The experimental arrangements employed in the present experiments are shown in Fig. 2. Direct absorption monitoring, laser-induced fluorescence, and optogalvanic detection are indicated. The violet semiconductor laser enabling the experiments on the  $4s-5p$  transition was acquired from Nichia Corporation (Type NLHV500) and has a nominal wavelength at 25 °C of 404 nm and an output power of 5 mW. The near-IR  $4s-4p$  transition was induced by a more conventional AlGaAs semiconductor laser (Mitsubishi ML4102) with a nominal wavelength of 772 nm and output power of 5

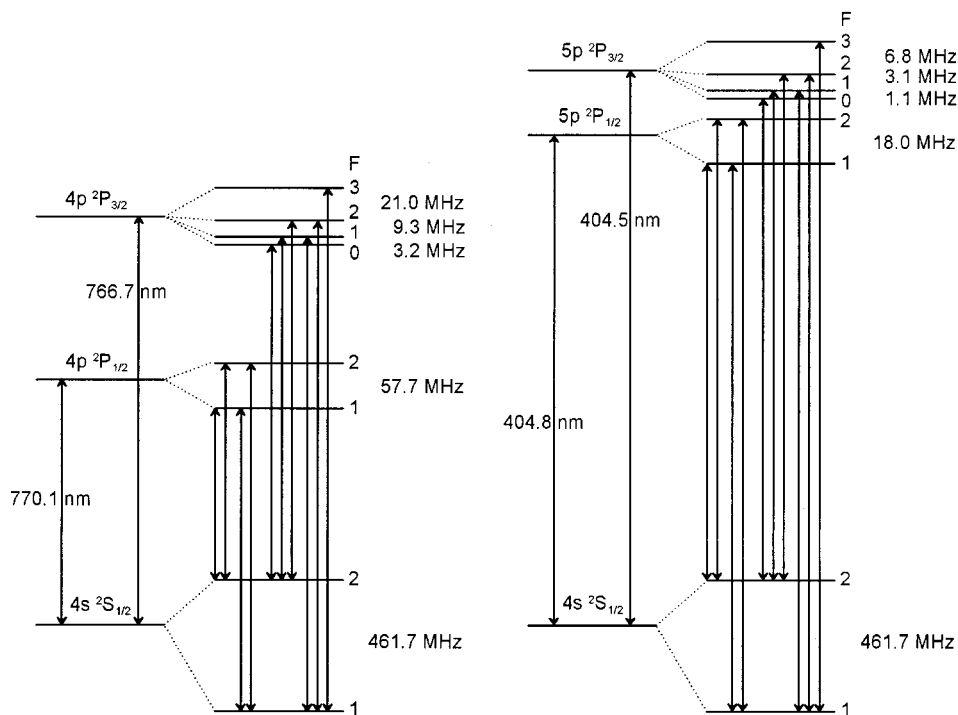

Fig. 1. Hyperfine structure diagrams of the  $4s^2S_{1/2}-5p^2P_{3/2,1/2}$  and the  $4s^2S_{1/2}-4p^2P_{3/2,1/2}$  transitions in  $^{39}\text{K}$ . The energy splittings are not given to scale.

mW. The laser diodes were placed in a thermo-electrically cooled mount (Thorlabs TCLDM9) and operated with a low-noise laser diode driver (Melles Griot 06DLD103). Typically, the operating currents of the two laser diodes were set to 40 and 59 mA, respectively. Wavelength tuning of the laser diodes was accomplished by changing the temperature of the laser capsule. Once the temperature was set, a current ramp with a frequency of 100 MHz or 100 Hz was added to the operating current by means of a function generator (Tektronix FG504), allowing us to record the whole line profile in a single scan. The lower frequency was used for the optogalvanic detection while the higher frequency was used for the absorption and fluorescence measurements. In some of the experiments with the violet diode laser, a simple external feedback cavity with a Littrow grating was used to ensure single-mode operation, since the free-running laser typically lased on a few modes, separated by about 0.05 nm. External cavity laser arrangements are commercially available from several suppliers, e.g., New Focus, Newport, Thorlabs, and Tui Optics, and we used the Thorlabs system based on the laser diode mount, a piezo-electric mirror mount (KC1-PZ), a piezo-electric driver (MDT-690), and a 2400 l/mm grating (Edmund Scientific 43224). A molded glass aspheric lens (Geltech C230TM-A) was used to collimate the output beam from the diode laser. Details for constructing a laser diode system, including external cavity and electronic control, from parts in the laboratory, are given in e.g. Ref. 5. The 4 cm long potassium cell, which was prepared on a vacuum station by distilling a small amount of the metal into the cell after thorough bake-out at elevated temperatures, was placed in a small electrically heated oven. The oven had small windows for transmitting the laser beam and a larger window for observing laser-induced fluorescence.

The transmitted laser beam was focused on a detector (Hamamatsu S1223 pin photo-diode in a home-made trans-impedance amplifier module) by an  $f=50$  mm lens (Thorlabs

BSX060-A). The detector output voltage was fed via a low noise amplifier (Stanford Research Systems SR560) to a signal averaging oscilloscope (Tektronix TDS520B). Finally, the recorded waveform could be transferred to a PC for processing and evaluation. A small part of the laser beam was split off by a beam splitter (neutral density filter) and sent to a low-finesse solid glass etalon with a free spectral range of 991 MHz in the near-IR region and 979 MHz in the violet. The generated fringes, which were detected by another detector, allow us to frequency calibrate each individual scan.

As an alternative detection method, the fluorescence induced by the violet transition could be monitored. The  $4p-4s$  near-IR transitions, isolated by a Schott interference filter ( $\lambda_{\text{peak}}=768$  nm), were used. By employing transitions from the  $4p$  state, populated in cascade decays via the  $5s$  and  $3d$  states, instead of the direct decays on the violet  $5p-4s$  transition, problems with background due to scattered light from cell windows and oven structures could be completely avoided. A photomultiplier tube (EMI 9558) was employed and the signal was fed via a current-to-voltage amplifier (Ithaco 1212) to the oscilloscope. We also tested a simple large-area photo-diode (Hamamatsu S-1226-8BK) for recording the fluorescence with quite satisfactory results.

The use of a hollow-cathode discharge lamp and optogalvanic detection is a further alternative for observing the blue potassium transitions. We used an Instrumentation Laboratory hollow-cathode lamp (Model 89227), intended for an atomic absorption spectrophotometer. A discharge current of 5 mA, also passing through a ballast resistor, was driven by an Oltronik photomultiplier supply (Model A2.5K-10HR), set for typically 300 V when the discharge was running. A rotating chopper (Stanford Research System SR540) was used for modulating the laser beam at 340 Hz, and the ac voltage across the ballast resistor occurring when atoms are excited was detected with a lock-in amplifier (EG&G 5209).

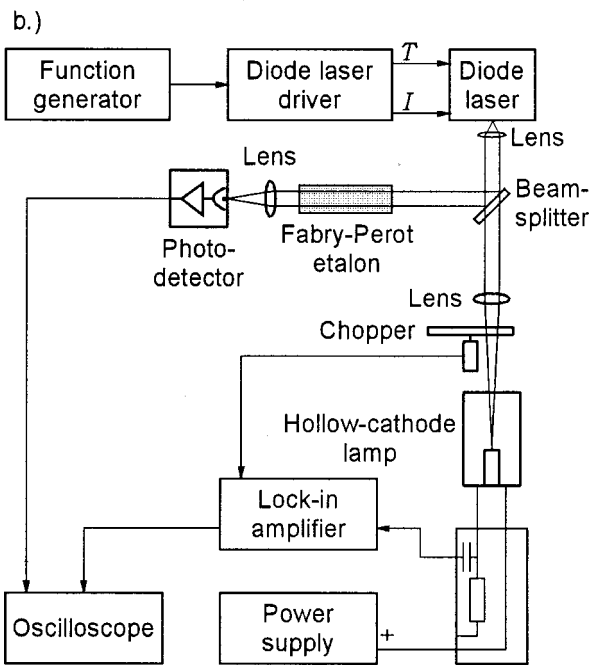
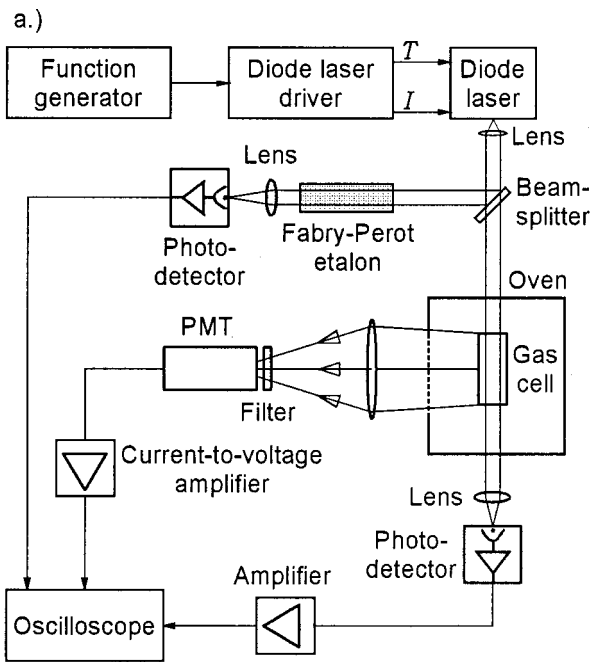

Fig. 2. Experimental setup for absorption, fluorescence (a) and optogalvanic spectroscopy (b) on potassium atoms.

### III. MEASUREMENTS

The experimental setup was first tested by inducing the  $4s^2S_{1/2}-4p^2P_{1/2}$  transition in the near-IR spectral region. This transition has, like the corresponding resonance lines in Rb and Cs,<sup>3-8</sup> high oscillator strengths, meaning a strong absorption already at atomic densities of  $10^{15}/\text{m}^3$ , corresponding to about  $50^\circ\text{C}$  for potassium. Thus, the transitions are easily observable in absorption measurements. The near-IR transition was induced with the Mitsubishi laser operated without an external cavity. Raw data for a potassium absorption measurement are shown in Fig. 3, where the low-finesse Fabry-Perot fringes are also displayed. It can be noted that the laser output power increases during the scan,

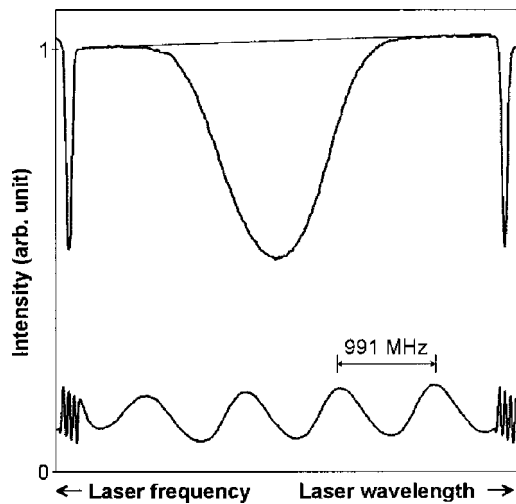

Fig. 3. Raw data obtained in an absorption recording of the  $4s^2S_{1/2}-4p^2P_{1/2}$  potassium transition. Note the increasing laser output over the scan, but the quasi-linear frequency sweep as evidenced by equidistant Fabry-Perot fringes. The signals associated with the retrace at the end of the saw-tooth sweep are also evident.

but that the frequency sweep is quite linear. Thus, no frequency scale rectification was employed in our experiments, but the recorded curves were normalized the case of a constant laser output by dividing the recorded curve by a curve without atomic absorption. This procedure, like all subsequent data processing, was readily performed within the Microsoft EXCEL data package. The data shown in the rest of this paper are all preprocessed in this way. Typical normalized recordings for different vapor cell temperatures are shown in Fig. 4(a). By reflecting the laser beam back onto itself, saturated absorption signals with increased transmission are seen separated by about 460 MHz as displayed in Fig. 4(b). The excited state hyperfine structure is not resolved. In between the two signals a strong cross-over signal<sup>1</sup> is observed. In these measurements, performed with a beam size of about  $1\text{ mm}\times 3\text{ mm}$ , care was exercised to avoid a direct feedback of the reflected beam into the diode laser which causes unstable oscillation. In the figure, an experimental curve recorded without beam reflection is superimposed, making an isolation of the nonlinear spectroscopic features easy.

Since the fluorescence is strong on the near-IR lines, the background due to scattering in cell windows, etc., is not severe, allowing the laser-induced fluorescence to be readily observed as shown in Fig. 5. Fitted curves, to be discussed later, are included in the figure. The lower trace shows the Doppler-free features due to the back-reflection of the beam into itself from the glass cell with normal-incidence windows.<sup>12</sup> The cross-over signal and one of the Doppler-free signals is clearly discernible. In the upper trace, we have misaligned the gas cell to only record the Doppler-broadened profile.

The  $4s-5p$  violet transitions in potassium have much smaller oscillator strength than the near-IR transitions. Thus, considerably higher temperatures are needed on the cell to observe line absorption. In contrast, fluorescence detection, which in this case is background free, is already possible at temperatures as low as  $30^\circ\text{C}$ . A transmission trace showing the violet line absorption on the  $4s^2S_{1/2}-5p^2P_{3/2}$  transition is displayed in Fig. 6(a). This recording is performed with

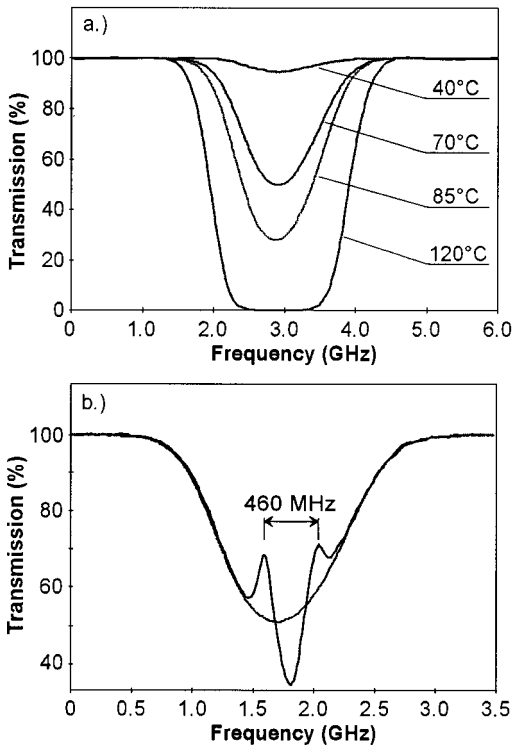

Fig. 4. Absorption recording on the  $4s^2S_{1/2}-4p^2P_{1/2}$  potassium transition recorded for (a) different cell temperatures and (b) saturated absorption signal when the laser beam is reflected back on itself for a cell temperature of 70 °C.

the violet laser operating in the external cavity. The  $4s^2S_{1/2}-5p^2P_{1/2}$  transition was observed in a separate scan. For the weak violet transitions it is more difficult to reach strong saturation conditions and the Doppler-free signals were not observed in our experiments. A fluorescence recording of the same transition is shown in Fig. 6(b), together with fitted curves to be discussed later.

Optogalvanic detection<sup>1,2</sup> in a discharge relies on the fact that excited atoms are more easily ionized by electronic impact than ground-state atoms. Thus, when chopping the excitation beam, a corresponding ac component occurs in the discharge current at resonance. An optogalvanic lock-in re-

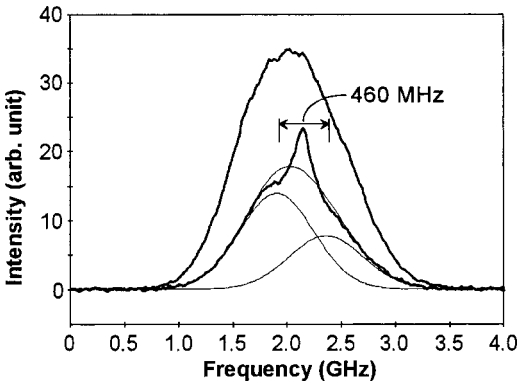

Fig. 5. Fluorescence recordings of the  $4s^2S_{1/2}-4p^2P_{1/2}$  transition using a single laser beam, crossing a potassium vapor cell. The lower trace (magnified 4×) shows Doppler-free features by a back-reflection from the cell windows. The cell temperature was 40 °C for the lower trace and 60 °C for the upper trace.

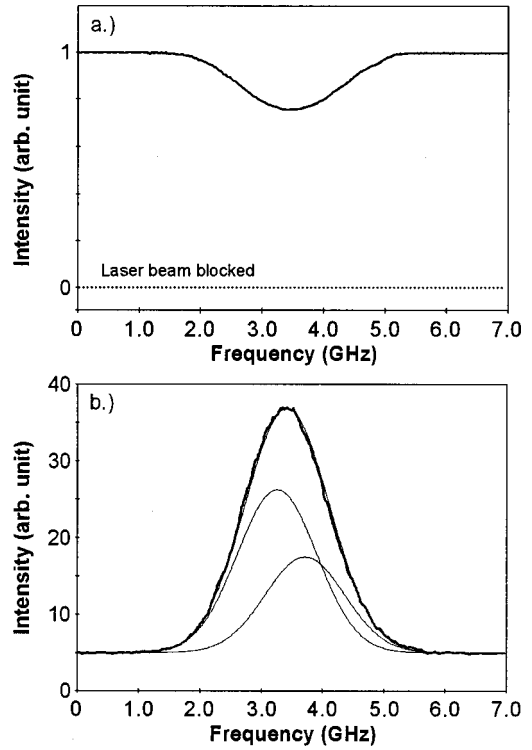

Fig. 6. Absorption (a) and fluorescence (b) recordings of the  $4s^2S_{1/2}-5p^2P_{3/2}$  transition in potassium. The cell temperature was about 130 °C for the absorption recording and 70 °C for the fluorescence recording.

ording of the  $4s^2S_{1/2}-5p^2P_{3/2}$  transition is shown in Fig. 7. Here the violet laser was operated in free-run without using an external cavity. As mentioned above, the laser was then not running in a single longitudinal mode, as evidenced in separate tests using a high-resolution spectrometer. Laser output spectra without and with an external cavity are given in the insert of the figure. Note that for free atoms with isolated spectral features as in our case, the general spectral appearance is not influenced since only one of the oscillating modes interacts with the atoms. However, some broadening of the individual mode linewidth in multi-mode operation make spectral recordings less suited for line-shape studies such as those in the present experiments. For molecules with

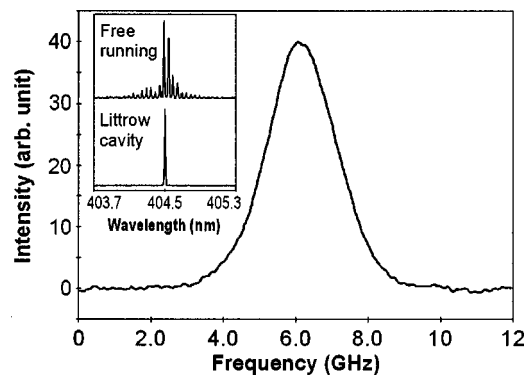

Fig. 7. Optogalvanic spectrum of the  $4p^2S_{1/2}-5p^2P_{3/2}$  transition in potassium. The insert shows the laser diode output spectra when the laser diode is operating without and with an external cavity.

a multitude of close-lying lines, multi-mode behavior is, of course, unacceptable.

#### IV. DISCUSSION

Diode laser spectroscopy for the violet and near-IR  $s-p$  transitions in potassium was demonstrated using simple equipment. Potassium has not previously been used in student laboratory work. With the very recent availability of violet semiconductor lasers, it became possible to directly excite, for the first time to our knowledge, a more highly excited state of an alkali atom with a laser diode. The outcome could then be compared with the results from experiments involving the first excited state, performed with the same simple setup.

The pedagogical value of a laboratory session along the lines discussed in this paper in part consists of running and scanning the diode lasers, and of adjusting the optical components and electronic devices for allowing the spectroscopic recordings, which could be demonstrated with three different detection methods. The other part is the atomic physics content. For this part, a useful approach is to record the near-IR  $4s^2S_{1/2}-4p^2P$  transition in fluorescence and absorption for single and double laser beam passage through the cell. Since the upper-state hyperfine structure for the present purpose could be considered to be absent, the two Doppler-free peaks directly allow the ground-state splitting to be evaluated. The fluorescence line-shape  $S(\nu)$  recorded for single-beam passage can then be fitted to a sum of two Gaussians with a half-width (FWHM) of  $\Delta\nu$ , separated by 460 MHz and having an intensity ratio of  $A:B$ ,

$$S(\nu) = A \exp(-4 \ln(2)(\nu/\Delta\nu)^2) + B \exp(-4 \ln(2)((\nu+460)/\Delta\nu)^2). \quad (1)$$

The value for  $\Delta\nu$  obtained is then compared with the theoretical value  $\Delta\nu_D$ :

$$\Delta\nu_D = \sqrt{\frac{(8 \ln 2) RT}{c^2 M}} \nu_0, \quad (2)$$

where  $\nu_0$  is the transition frequency at line center,  $R$  is the gas constant [8.3143 J/mol K],  $c$  is the speed of light,  $T$  is the cell temperature (in K), and  $M$  is the atomic mass number (39). The Doppler width for the near-IR transition is about 0.8 GHz for the temperatures discussed here (20 °C–120 °C).

With the violet laser a substantially broader fluorescence lineshape is then recorded and fitted to Eq. (1), and the Doppler width is extracted. Now the transition frequency is a factor of 1.90 higher and the violet theoretical Doppler width is correspondingly larger, typically 1.5 GHz using Eq. (2).

For both lines, good fits and experimental widths close to the calculated ones are obtained, e.g., the fits included in the fluorescence recordings in Figs. 5 and 6 yield 0.82 GHz (40 °C) and 1.55 GHz (70 °C), respectively, for the Doppler widths, to be compared with the theoretical values of 0.79 and 1.57 GHz, respectively. The good curve fits obtained using Gaussians and the experimental Doppler width values obtained in two widely separated wavelength ranges strongly support the theory for Doppler broadening. A discussion of the velocity Maxwellian distribution and Doppler broadening can be found, e.g., on p. 67 of Ref. 1 and p. 86 of Ref. 2.

The ratio of the statistical weights of the two hyperfine ground state levels ( $F=2$  and  $F=1$ ) is 5:3, which is also the

expected line intensity ratio ( $A/B$ ) for transitions to an unresolved excited state. The experimentally deduced intensity ratios, 1.80 and 1.71, respectively, for the curves in Figs. 5 and 6 are close to the theoretical ratio, 1.67.

A further suitable violet transition for a student laboratory session is the aluminum 397 nm line. The  $3p^2P_{1/2}-4s^2S_{1/2}$  transition at 396.2 nm for the single aluminum isotope  $^{27}\text{Al}$  with a 1.26 GHz  $S$ -state hyperfine splitting allows very pedagogical optogalvanic recordings from an aluminum hollow-cathode lamp. A calcium hollow-cathode lamp run at a somewhat higher discharge current than normal produces  $\text{Ca}^+$  ions with its potassium-like resonance transitions at 393.5 and 397.0 nm, respectively, which could be monitored by optogalvanic spectroscopy. An interesting pedagogical observation is, then, that the first excited state in potassium-like  $\text{Ca}^+$  is located at about the same energy as the second excited state in potassium, due to the excess charge of the calcium nucleus.

#### V. CONCLUSION

We have performed laser diode spectroscopy in the near-IR and violet spectral region on potassium. The experiments demonstrate the possibility to perform simple and inexpensive laser spectroscopy on Doppler-broadened profiles of the same atom in different spectral regions, allowing the experimental verification of the theory for Doppler broadening at two widely separated wavelengths.

#### ACKNOWLEDGMENTS

This work was supported by the Swedish Research Council for Engineering Sciences (TFR) and the Knut and Alice Wallenberg Foundation.

<sup>1</sup>W. Demtröder, *Laser Spectroscopy* (Springer Verlag, Heidelberg, 1996), 2nd ed.

<sup>2</sup>S. Svanberg, *Atomic and Molecular Spectroscopy—Basic Aspects and Practical Applications* (Springer Verlag, Heidelberg, 1997), 2nd ed.

<sup>3</sup>J. C. Camparo and C. M. Klimac, "Laser spectroscopy on a shoestring," *Am. J. Phys.* **51** (12), 1077–1081 (1983).

<sup>4</sup>S. Diop, "Utilisation des lasers a semi-conducteurs (AlGaAs) en spectroscopie d'absorption de saturation et de modulation de frequence dans le rubidium ( $^{85}\text{Rb}$  et  $^{87}\text{Rb}$ )," Thesis for Maitre es Science, Universite Cheikh Anta Diop de Dakar, 1997.

<sup>5</sup>K. B. MacAdam, A. Steinbach, and C. Wieman, "A narrow-band tunable diode laser system with grating feedback, and a saturated absorption spectrometer for Cs and Rb," *Am. J. Phys.* **60** (12), 1098–1111 (1992).

<sup>6</sup>C. Wieman and L. Hollberg, "Using diode lasers for atomic physics," *Rev. Sci. Instrum.* **62** (1), 1–20 (1991).

<sup>7</sup>K. G. Libbrecht, R. A. Boyd, P. A. Willems, T. L. Gustavson, and D. K. Kim, "Teaching physics with 670 nm diode lasers—construction of stabilized lasers and lithium cells," *Am. J. Phys.* **63** (8), 729–737 (1995).

<sup>8</sup>L. Ricci, M. Weidemüller, T. Esslinger, A. Hemmerich, C. Zimmermann, V. Vuletic, W. König, and T. W. Hänsch, "A compact grating-stabilized diode laser system for atomic physics," *Opt. Commun.* **117** (5–6), 541–549 (1995).

<sup>9</sup>S. Nakamura and G. Fasol, *The Blue Laser Diodes* (Springer Verlag, Heidelberg, 1997).

<sup>10</sup>S. Nakamura and W. Kaenders, "Market-ready blue diodes excite spectroscopists," *Laser Focus World* May 1999, 69–75.

<sup>11</sup>E. Arimondo, M. Inguscio, and P. Violino, "Experimental determinations of the hyperfine structure in the alkali atoms," *Rev. Mod. Phys.* **49** (1), 31–75 (1977).

<sup>12</sup>T. P. Duffey, D. Kammen, A. L. Schawlow, S. Svanberg, H. R. Xia, G. G. Xiao, and G. Y. Yan, "Laser spectroscopy using beam overlap modulation," *Opt. Lett.* **10** (12), 597–599 (1986).