



LUND UNIVERSITY

Aerosol characterization in real life and a methodology for human exposure studies in controlled chamber settings

Isaxon, Christina

2014

[Link to publication](#)

Citation for published version (APA):

Isaxon, C. (2014). *Aerosol characterization in real life and a methodology for human exposure studies in controlled chamber settings*. [Doctoral Thesis (compilation), Ergonomics and Aerosol Technology].

Total number of authors:

1

General rights

Unless other specific re-use rights are stated the following general rights apply:

Copyright and moral rights for the publications made accessible in the public portal are retained by the authors and/or other copyright owners and it is a condition of accessing publications that users recognise and abide by the legal requirements associated with these rights.

- Users may download and print one copy of any publication from the public portal for the purpose of private study or research.
- You may not further distribute the material or use it for any profit-making activity or commercial gain
- You may freely distribute the URL identifying the publication in the public portal

Read more about Creative commons licenses: <https://creativecommons.org/licenses/>

Take down policy

If you believe that this document breaches copyright please contact us providing details, and we will remove access to the work immediately and investigate your claim.

LUND UNIVERSITY

PO Box 117
221 00 Lund
+46 46-222 00 00

Aerosol characterizations in real life and a methodology for human exposure studies in controlled chamber settings

Christina Isaxon



LUND
UNIVERSITY

DOCTORAL DISSERTATION

by due permission of the Faculty of Technology, Lund University, Sweden.

To be defended at Stora Hörsalen, IKDC, Lund. Date 2014-02-21 and time 10:15

Faculty opponent

Tareq Hussein

Organization LUND UNIVERSITY	Document name Doctoral Thesis	
Department of Design Sciences Division of Ergonomics and Aerosol Technology	Date of issue 2014-01-17	
Author(s) Christina Isaxon	Sponsoring organization	
Title and subtitle Aerosol characterization in real life and a methodology for human exposure studies in controlled chamber settings		
<p>Abstract</p> <p>Airborne particles are everywhere around us, and have always been. Particles generated by human activities has increased drastically since industrialization, and several epidemiological studies have shown that inhaled particles can cause adverse health effects. The concern about health effects have during the last decade shifted towards fine and ultrafine particles, not least due to the emerging field of nanotechnology. Of special interest are the particles to which we are exposed indoors – in the industrialized part of the world we spend around 90% of our time indoors (at home and at workplaces/schools). Particles generated in these environments often cause intense peaks in concentration, and are often consequences of our own activities. Especially combustion/thermal processes (such as welding, frying, burning candles etc.) cause peaks in number concentration, often more than an order of magnitude higher than ambient concentrations.</p> <p>We have conducted time-resolved particle measurements in several homes which confirm this. From these measurements, we have been able to show just how much occupants' activities affect the indoor concentration of ultrafine particles compared to outdoor concentrations. We have also estimated e.g. total integrated daily exposure. Exposure and emission measurements have also been conducted at a carbon nanotube producing facility, and a method for counting particles containing carbon nanotubes has been suggested and validated.</p> <p>Why certain particles are more dangerous than others is often investigated in animal exposure studies, where exposure levels are unrealistically high. For several reasons, the results of such studies are not simple to translate to the human system. To increase our understanding of which particle properties can cause effects in humans, a methodology for conducting human exposure studies have been developed and validated. In a controlled chamber we have exposed human test subjects to normal concentrations of common particle types; candle smoke, particles from terpene–ozone reactions and welding fume. Together with medical expertise, we have been looking for effects of these exposures. By using non-invasive tests (e.g. urine and blood samples and ECG) biochemical markers of exposure, and changes in heart rate variability (HRV) have been studied. A significant increase in the high frequency domain of the HRV during exposure for candle smoke was found.</p>		
Key words: Aerosol, human exposure study, exposure, emission, ultrafine particles, aerosol generation, aerosol characterization, candle, terpene, welding, CNT, indoor		
Classification system and/or index terms (if any)		
Supplementary bibliographical information		Language: English
ISSN and key title: 1650-9773 Publication 47		ISBN: 978-91-7473-856-8
Recipient's notes	Number of pages: 228	Price
	Security classification	

I, the undersigned, being the copyright owner of the abstract of the above-mentioned dissertation, hereby grant to all reference sources permission to publish and disseminate the abstract of the above-mentioned dissertation.

Signature

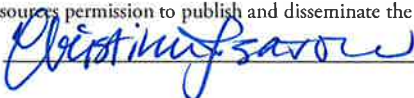

Date 2014-01-16

Aerosol characterizations in real life and a methodology for human exposure studies in controlled chamber settings

Christina Isaxon
Doctoral Thesis 2014



LUND
UNIVERSITY

Copyright © Christina Isaxon

Faculty of Engineering, Department of Design Sciences
www.design.lth.se

ISBN 978-91-7473-856-8 (Printed)

ISBN 978-91-7473-857-5 (Pdf)

ISSN 1650-9773 Publication 47

Printed in Sweden by Media-Tryck, Lund University
Lund 2014



*To my brother, Torbjörn,
who never got to attend my dissertation party.*

Acknowledgements

So many people have helped me during my years as a PhD student and contributed, in one way or the other, to this thesis. From the bottom of my heart, I want to thank you all. With the risk of forgetting someone, a number of people deserve special thanks:

First and foremost I want to express my warmest gratitude to my supervisor Mats Bohgard. You seem have a miraculous way of making people grow by trusting in their ability to do so. Thank you for giving me responsibilities, and freedom to pursue the ideas I come up with. Thank you for believing in me. Thank you for all scientific input, and for all feedback. A complete list of all reasons I have to thank you would be too long to be printed here.

Aneta Wierzbicka, thank you for always taking time to answer my questions and for all the time spent on my ridiculously-close-to-deadline contributions, for being a great travel companion, for introducing me to all your friends in the scientific community. You are so kind, wise, ambitious, caring, and humble – a role model for young females in the academy. When I grow up I want to be like you! 😊

Thank you, Anders Gudmundsson, for your unbelievable ability to see solutions where others see problems, for all your support and feedback, for your great attitude towards everyone, and for very interesting discussions, about science and other things.

Thanks also to Joakim Pagels, for always taking time to patiently share your profound knowledge, for teaching me the importance of critically analyze obtained results. Thank you also for being a great supervisor for my diploma work.

Jenny Rissler, thanks for being so inspirational, for all interesting discussions concerning those fascinating carbon nanotubes, our lungs, and everything else that matters.

Erik Nordin, thanks for all interesting discussions about everything from statistical analysis to political views, for being a really good office-room mate, and for helping out with the aerosol course every year, and this year in particular. I certainly owe you a favor or two!

Jakob Löndahl, thanks for, among other things, all the last minute help with instruments and software in general, and in particular for constructing the TEOM

Labview program, without which the exposure monitoring would have been a lot more difficult.

Andreas Dahl, thank you for all work you did in the residential measurement campaign, good laughs, helping me out in the aerosol laboratory, and much else.

Thanks to Christian Svensson for being a really good and supportive colleague, for your nice attitude towards everyone, and for being a good, and very funny, friend. Axel Eriksson and Patrik Nilsson, thanks for good cooperation, for many laughs and, not least, always answering my questions about the AMS.

I am very thankful for having such nice and brilliant colleagues. Erik Swietlicki, Birgitta Svenningsson, Adam Kristensson, Moa Sporre, Cerina Wittbom, Erik Ahlberg, Pontus Roldin, Johan Genberg, Emilie Hermansson and Jonas Jakobsson, thank you all for good support, interesting discussions and contributing to a splendid working environment.

Thank you, Karin Lundgren, for great travel companionship in India, and for involving me in your projects towards making this world a better place for people who do not have jobs as lovely as ours.

I want to thank everybody at the department of Occupational and Environmental Medicine, in particular Jörn Nielsen, Katrin Dierschke, Maria Hedmer, Maria Albin, Håkan Tinnerberg, Jan-Eric Karlsson, Eva Assarsson, Ulla-Britt Andersson, Else Åkerberg Krook and YiYi Xu for very good and fruitful cooperation and for teaching me so much about occupational medicine.

Inger Hagerman and Margareta Berglund, thank you for very good cooperation, for teaching me about the human nervous and cardiovascular system, and for always answering my many questions about HRV.

Gunilla Wieslander, thank you for good cooperation, long and fruitful conversations over the phone, and in real-life, and for helping me out with facts and figures on short notice whenever I have needed. Thanks also to Dan Norbäck.

Thanks to everybody at Solid State Physics, in particular Maria Messing, for always answering my questions without delay, for good times at conferences and for being very inspirational, Linus Ludvigsson for being a state-of-the-art diploma worker and for all beautiful SEM images, and Knut Deppert, for being so kind, nice and supportive, and, of course, for taking time to lecture at the aerosol course.

Göran Frank, thank you for keeping such good order in the aerosol lab, despite all the mess we create. What would we do without you?

Jessika Sellergren, thank you for all help with Typo3 and for interesting discussions about (among other things) layout and graphics.

Gerd Johansson, thank you so much for all your support and encouragement. Karin Öhrvik, Lena Leveen, Susann Nordbeck, Robert Olsson, without you I would get nothing done. You are the glue keeping this department of preoccupied scientists together.

Thanks also to Ylva Löfgren, Kristel Öhman, Kicki Ahlsén and Maria Ingloff for always providing quick help with everything practical. I cannot imagine how things here would work without your excellent abilities of problem solving.

A huge thank also to all people who have opened up their homes to us for the indoor measurement campaign, and to all volunteers in our exposure chamber. Without all of you, this thesis would not exist.

I want to thank those who are especially important to me: all my wonderful friends, no-one mentioned, no-one forgotten. I have been absent lately – and when present, absent-minded. Thanks for being supportive and for bearing with me. And for providing a world of other interesting things, apart from aerosols!

Barbro and Roland, my beloved parents: if it was not for your continuous love and support throughout my life I would be nowhere near where I now am. Thank you for everything!

Joachim Bielecki, I managed to take my master in engineering thanks to your support. Thanks also, to both you and Sara, for helping out and rearranging our schedule with the kids whenever I have needed.

Clea Bielecki Isaxon, Loke Bielecki Isaxon, and Loke Lönnblad Ohlin, sorry that I have been a bit preoccupied lately, and thanks for being understanding. You are great kids! I hope these last weeks of seeing me constantly in front of the computer frantically writing and covering furniture and floor with scientific articles has not discouraged you from further studies. Stay in school – you won't regret it!

Most importantly, Leif Lönnblad: I cannot even begin to thank you. You are always there for me. You have rearranged our home into a workspace for me these latest weeks, and completely selflessly provided me with everything I need to focus. You have been proof reading this manuscript over and over. And during all my time as a PhD student, you have taught me immensely much about how to look at things with a scientific eye, and a scientific mind. Thanks for all our interesting and inspiring discussions, for good laughs and a lot of love and caring. You mean the world to me!

Contents

Svensk sammanfattning	1
Aerosol science for the non-aerosol scientist	3
How should this thesis be read?	7
What will be going on during the defense?	7
1. Introduction	9
2. Studies of emissions and exposures	13
2.1 Indoor sources	14
2.1.1 Air measurements in residential dwellings	16
2.1.2 Candle smoke	18
2.1.3 Particles generated by terpene-ozone reactions	19
2.2 Workplace sources	20
2.2.1 Strategies for workplace measurements	21
2.2.2 Welding fume	22
2.2.3 Manufactured nano objects	25
3. Particle generation and characterization for exposure studies	30
3.1 Candle smoke generation	31
3.2 Generation of particles from terpene-ozone reactions	33
3.3 Welding fume generation	35
4. Human exposure studies	38
4.1 Exposure chamber	38
4.2 Study design	41
4.3 Medical examinations and biochemical markers	42
4.4 Heart Rate Variability	43
5. Instruments and analysis methods	46
6. Summary and outlook	50

Summary of the articles	53
Author's contribution to presented articles	58
Author's publications, not presented in this thesis	60
Referenses	65

Svensk sammanfattning

Ta ett djupt andetag och tänk på vad du nu har i lungorna!

Jo, det är luft, förstås, syre kväve och sådant. Men det är också något annat. I varje kubikcentimeter du andas in finns tusentals partiklar, alla för små för att kunna ses med blotta ögat. Om dessa partiklar handlar denna avhandling. Vi kallar luftburna partiklar för aerosoler, ett begrepp som innefattar allt från de minsta nanopartiklarna, som ofta skapas av det vi människor gör, som transport och industri, till de största, som ofta har naturliga källor. Om jag skulle förstora den minsta partikeln du just andades in till storleken av huvudet på en knappnål, skulle den största bli stor som Globen i Stockholm. Partiklar finns överallt, speciellt mycket i städer, men ingenstans på jorden är luften partikelfri eller har någonsin varit.

I genomsnitt andas du in ungefär 100 miljarder partiklar varje dag. En hel del av dem andas du ut igen, men de minsta partiklarna kan följa med luften ända ner till de känsligaste delarna av lungan och stanna kvar där. Vi vet, från flera epidemiologiska studier, att partiklar i luften orsakar en mängd sjukdomar i inte bara i andningsvägarna. Men epidemiologiska studier berättar ingenting om orsaken; om det är partiklarnas storlek, deras form, deras kemiska sammansättning, eller någon annan egenskap som orsakar sjukdomen. Denna avhandling förklarar hur vi har gått tillväga för att utarbeta en metod, som vi hoppas ska kunna bättra på vår kunskap om vad det är som gör att vissa partiklar är farliga och andra inte.

Metoden går ut på att placera frivilliga försökspersoner i en välkontrollerad kammare, där de sitter bekvämt och under 3-5 timmar blir exponerade för normala koncentrationer av vanliga aerosoltyper. Vi låter dem andas in en specifik aerosol per exponeringstillfälle, och vid ett tillfälle får de även andas in helt partikelfri, filtrerad luft. Egenskaperna hos aerosolen i fråga har vi innan undersökt noga, så vi känner till sådant som hur stora partiklarna är, hur de ser ut och vilken kemisk sammansättning de har. Tillsammans med medicinska forskare försöker vi, under tiden exponeringen pågår och efter, hitta någon effekt hos de här försökspersonerna, något som skiljer sig från då de bara andas in den filtrerade luften. Det kan röra sig om till exempel en liten förändring i mängden av ett visst protein, som tyder på en begynnande inflammation, eller att hjärtats rytm förändras. Med andra ord, något som berättar för oss att det finns något hos just den här aerosolen som får kroppen att reagera. Genom

att prova oss igenom flera olika aerosoler på det här sättet hoppas vi kunna komma ett steg närmare att förstå vilka egenskaper som gör vissa partiklar farligare än andra.

Vi har valt att titta på aerosoler från både arbetsmiljö (svetsrök) och inomhusmiljö (stearinljusrök samt de partiklar som bildas då flyktiga organiska kolväten – sådana som får våra rengöringsprodukter att lukta gott – reagerar med ozon). Avhandlingen förklarar hur vi gått till väga då vi bestämt oss för lämpliga koncentrationer att använda vid exponeringarna, och hur vi burit oss åt för att ta reda på de egenskaper hos dessa partiklar som forskarvärden tror kan vara av betydelse för vår hälsa. Vidare beskrivs hur vi har utvecklat system för att generera dessa aerosoler så att vi vid varje exponeringstillfälle har fått samma koncentration av partiklar i kammarluften.

Vi har till exempel fått resultat som indikerar att våra försökspersoners hjärtrytm påverkades olika av stearinljuspartiklar än av andra partiklar på ett sätt som inte var till stearinljuspartiklarnas nackdel, något som vi just nu studerar närmare. Den i avhandlingen beskrivna metodiken har senare även använts för dieselavgaser, och framöver ska vi titta på hur våra försökspersoner reagerar då de får andas in andra aerosoltyper, som matos eller de avhärdande partiklar som finns i vanliga tvättmedel.

Aerosol science for the non-aerosol scientist

This thesis will explain the work in which I have participated in during my PhD studies. As in most other sciences, research within the field of aerosol science is not a one-man-job, but rather the joint efforts of many people. I was recently challenged to in three minutes explain the work I do, for an audience who knows nothing about aerosols. This was what I said:

Before I start explaining, let's take a deep breath. Breathe in, think of what you now have in your lungs, and breathe out. Sure, it is air, of course. Oxygen, nitrogen and such. But there's also something else. In every cubic centimeter of air you just inhaled there were thousands of particles, all of them too small to be seen by the naked eye. This is my field of research. From the smallest nanoparticles, which often are caused by our own activities, such as transport or industry, to the largest ones, which often have natural sources. If I was to enlarge the smallest of the particles you just inhaled to the size of the head of a pin, the largest one would be seven times the volume of Royal Albert Hall. Particles are everywhere, especially in urban areas, but the air is not free from particles anywhere on earth, nor has it ever been.

So, if you again, breathe in ... and out, how many particles ended up in your lung? Well, on average you inhale some 100 billion particles every day! We actually exhale many of them again. But the smallest particles tend to follow the air stream all the way down to the most vulnerable parts of the lungs, and stay there. We know, from epidemiology, that airborne particles cause several diseases, not only in the respiratory tract. But these kinds of studies cannot tell us if it was the size of the particles, the shape, the chemical composition, or some other particle property which caused the harm. I try to figure out what makes some particles dangerous and some not.

I work with medical and biochemical scientists, and together we conduct human exposures. We place volunteers in a controlled chamber and let them

breathe in air with a normal level of a common particle type, about which we know every possible characteristic. We then look for effects in the humans – maybe only small changes in some protein related to inflammation, or in heart rate, which indicate that there is something about this particle type that makes the body react. By trying several different types of particles in this way, we hope to figure out what properties that makes some particles more dangerous than others. This knowledge can be very important, not least when governments need to set health limit values. Especially now, in the new age of engineered nanoparticles, we really need to think carefully about what we breathe.

Well, in three minutes, you do need to simplify things quite much. But I think it basically covers it pretty well. However, since I now have the opportunity, I can go into more detail.

When asked what I do for a living, I seldom answer that I deal with aerosols. After having explained that I do not produce spray cans too many times, I have refrained to say that I study airborne particles, and that I by that basically mean air pollution. Aerosol science is not the study of spray cans. Aerosol science is the study of particles suspended in a gas.

For a particle to actually be a particle, and not an unstable cluster of molecules, it needs to be at least one, or rather a couple of nanometers in diameter. A nanometer is one billionth of a meter (commonly written as 10^{-9} m). This is really, I mean *really*, small. One nanometer is the length your beard grows (if you're blessed with one) from the moment you pick up your razor from the washstand until you place it at your chin. On the other side of the size span, a particle which shall remain in suspension, at least for a reasonable amount of time, cannot be too large, otherwise it will fall down due to gravity. A particle which is 100 μm in diameter (approximately the diameter of a human hair) will fall 1 meter in 3 seconds, which is arguably the limit of what can be considered airborne. It is five orders of magnitude between 1 nanometer and 100 micrometers, which indeed is a huge span (see above about the pin needle and Royal Albert Hall).

That was the particle part of the aerosol. What about the gas? In almost all cases when we talk about aerosol, the gas is that mixture of 78% nitrogen and 16 % oxygen, water vapor, and some trace amounts of other gases, we know so well and inhale from birth to death.

So, the air we breathe is an aerosol. Everywhere on earth there are - more or less - airborne particles, and many types of them have always been around. Before humans started to add more, and often new, types of particles to the air, we had the natural particle sources. Of course, those we still have. For example, particles from volcano

eruptions, particles from mechanical disintegration of solid material (erosion), salt particles emitted from the oceans (the emission of salt particles from all the oceans put together amounts to the quite amazing number of 5.9 billion tons per year) or particles from wild fires. Also, pollen, spores, airborne viruses and bacteria are aerosol particles originating from natural sources. Alongside of the natural sources we have one other main type of particle source: you and me. We create particles both outdoors and indoors. Outdoors, the particles typically come from transport and industry. In our homes (where we on average spend 65% of our time) we generate particles by e.g. cooking, cleaning, doing the laundry, burning candles or incense - even when we peel an orange we create particles. At work we of course also generate particles; in industries such as welding or grinding we generate quite a lot. Sometimes, however, the particle generation is the purpose of the industry, such as in the case of engineered nanoparticles. In chapter 2, the particles we are exposed to in our homes and at some workplaces will be described in more detail.

Airborne particles do not remain airborne forever; they are deposited by different mechanisms. How a particle is affected by a deposition mechanism depends foremost on the size of the particle. Smaller particles – those “pin head” ones – are mainly deposited by a phenomenon called diffusion. A really small particle does not perceive the surrounding air in the same way as we do: as a continuum. The smallest particles are in the same size range as the gas molecules (oxygen, nitrogen and those) so the particles are continuously affected by collisions with these molecules. The particles will hence move about randomly in the air – this is called Brownian motion – until this journey takes them close to a surface, which could be the ground, the floor, a table or the inside of your lungs. The particles will stick quite firmly to this surface, due to a strong force called Van der Waals force. Larger, heavier particles, “Royal Albert Halls ones”, are not bothered by air molecules, instead their problems are with gravity. The heavier the particle the faster it will fall downwards due to this force. Particles of intermediate sizes, somewhere in between 100 and 500 nanometers, are too large to be affected by diffusing air molecules and too small to be noticeably affected by gravity. These can remain airborne for quite a long time. We call this size range of particles for the accumulation mode, since particles of these sizes tend to accumulate in the atmosphere.

Now, let's move along to what is likely the most important question: Are these particles dangerous? Can they affect our health? Well, it would be nice to have a straight forward answer to that. If there was one, this thesis would probably deal with something entirely different from what it does. And the question is relevant: we do on average inhale some 100 billion particles every day. Quite many of them are exhaled again, mainly those in the accumulation mode, which are not affected by the deposition mechanisms I just mentioned. The largest particles will, due to their inertia, have problems to follow the air stream when it changes direction (which it does often in the lung) and they will be deposited in the upper parts of the respiratory

system. The smaller particles are much better at following the air stream's twists and turns, and are quite likely to be able to reach the most vulnerable parts of the lung, the alveoli. This is the place where the blood gets rid of carbon dioxide and takes up oxygen, so the alveoli walls are very thin. These alveoli, of which we have 700 million, account for the major part of the area of the lung. Particles deposited in the branches of the bronchus are transported upwards by cilia hair, but in the alveoli we do not have any such mechanisms. Instead we have there a kind of white blood cells called macrophages, to take care of deposited particles. They engulf the particle, and use different enzymes to break it down and then transport themselves and what remains of the particle to a lymph node.

Since particles always have been present in the air, these defense mechanisms have been developed throughout times. But lately, especially since the industrialization era, the anthropogenic part of airborne particles has drastically increased. These particles are mainly in the smaller sizes. It seems as if our respiratory system is not totally prepared for this increased particle burden, and people do get sick because of these particles. It has been proven that airborne particles can cause several different diseases in the respiratory system – such as cough, increased risk of asthma, COPD¹ and infection – and in other parts of the body – such as cancer, cardiovascular problems, stroke and cardiac infarcts. But we do not exactly know why, and what properties of the particles cause these diseases. It may be shape, size, chemical composition, number- mass- or surface area concentration, solubility, you name it. This can be investigated in a couple of different ways. You can conduct in vitro exposure, animal exposure, or human exposure studies, for example. In vitro is when you expose cell cultures (for example human alveoli cells) to particles, and see to what degree they survive. This can teach us about what happens at cell level, but not really about how this would affect the whole complex system of the human body. In animal studies you can use high concentrations and/or toxic particle types and you can provoke the animals until they die. Then you can dissect them and find out what happened, for example, how many of the particles that ended up where. These kinds of studies, leaving the possible ethical dilemmas aside, are expensive and often only tell us things about the acute effects. They are also very difficult to translate to our human system. Animals are smaller, have different metabolism, different breathing patterns etc. These difficulties can be dealt with by using humans instead. Needless to say, you cannot provoke humans to the degree that they get sick or, god forbid, die. Nor can you dissect them. But what you can do is looking for so-called biomarkers of exposure. Long before we actually notice that we are sick, the body reacts. It may, for example, create more of a certain type of protein or enzyme, which can be seen in

¹ Chronic Obstructive Pulmonary Disease (KOL, in Swedish)

blood or urine samples, or in saliva. The ability to adjust the autonomous nerve system to changes may decrease, which can be shown as lowered heart rate variability by looking at a person's ECG (more about that in chapter 4.4). We have conducted these kinds of studies, where we have exposed people to different kinds of particles. Each person is his/her own control, in that everybody has been exposed twice, once to virtually particle free air and once to a well-defined type of particle. If something has changed, from the particle free exposure to the particle exposure, we can conclude that there was something about the particle type in question which made the body react. Since we beforehand know almost everything there is to know about the particles we use in the exposure studies (their shapes, sizes, concentrations, chemistry,...) we hope to be able to say which particle properties seem to be more responsible than others for affecting the human body. If we know this, we also will know how potentially dangerous a new particle type can be. This is indeed important knowledge, not least for the upcoming industry of engineered nanoparticles.

How should this thesis be read?

The thesis is basically divided into two parts. The first part is a summary of the current status within the field of research in which I have been working during my PhD studies. I will here also explain the background of what we have been doing, why it needed to be done, how we did it and what the main results were. I will also talk some about what more needs to be done. This part is divided into subchapters; each will start at "beginners' level" and proceed to be more advanced. The second part consists of some of the most relevant scientific articles which I have been involved in producing during my PhD studies.

What will be going on during the defense?

During the first part of a PhD defense, the defendant (in this case me) will give an overview of the work. The opponent will also give a presentation, which will put the work described in this thesis into context (meaning that he will explain where in the area of current aerosol science my work – hopefully - have contributed to increased knowledge). Then there will be an hour or so of discussion between the opponent and me about the work presented in this thesis. The general idea of this is that I need to show that I understand everything I have written about in the thesis. After that the committee will have the opportunity to raise additional discussion points, if they feel they have not already been covered. Last, there will be an opportunity for those still awake in the audience to ask questions.

If you are not an aerosol nerd, the defense may be quite tiring. After the defendant's presentation, the discussions are likely to be more and more detailed, but try to keep awake at least during this presentation, since this hopefully will clarify some of the things which will be discussed later on. Reading the first parts of the chapters will hopefully help you to follow the discussions. And make sure you have a large mug of coffee - there will be a short break between the presentations and the discussion, during which the toilet can be visited and the coffee mug refilled. If you, despite the immensely fascinating world of aerosols, eventually find yourself being a bit bored, you can try solving the Sudoku puzzles² in the very back of the thesis.

² Thanks to Simon Mitternacht for this idea!

1. Introduction

Particles are everywhere in the air around us, and have always been. Since the beginning of times, natural sources have generated particles. Examples of such sources are volcanos, wildlife fires, desert storms, erosion, vegetation, and the oceans. Evolution has equipped us with several ways of dealing with this exposure, mainly by the design of the interior of our noses, the development of cilia hairs and the macrophages in the respiratory tract, all of which have the purpose to remove particles which have been deposited in our lungs. How well a particle can follow the stream of inhaled air decides where in the lung it will be deposited. This is mainly a function of particle size; large particles get deposited quickly, due to their inertia, while a smaller particle can follow the air stream all the way down to the alveoli. The particle size distribution of an atmospheric (or indoor) aerosol generally has three size modes; the ultrafine mode, with particles smaller than 100 nm, the accumulation mode, with particles 100 nm to 1 μm , and the coarse mode, with particles larger than 1 μm . Particles that are generated by human activities – which are often combustion related – are generally ultrafine mode particles, smaller than those generated by nature – which often are created by disintegration of solid material and can be found in the coarse mode. Smaller particles are of special concern to human health since these, when inhaled, have a higher possibility than larger particles to follow the airstream and reach the alveoli tract of the respiratory system. During industrialization the anthropogenic contribution to the concentration of airborne particles increased significantly. In a report from the National Institute for Health and Welfare (THL) in Finland, particulate matter (PM) was estimated to be associated with the highest environmental burden of disease in Europe – 6000 to 10000 disability adjusted life years³ per million people – followed by second-hand smoke, traffic noise and radon [Hänninen et al., 2011].

Studies on health effects of air pollution indicate that airborne particles can cause a variety of diseases and are responsible for increased morbidity and mortality (e.g. respiratory and cardiovascular diseases) in polluted areas [Li et al., 2003; Dockery, 2009;

³ Disability adjusted life years (DALYs) is a burden of disease metric that combines years of life lost and years lived with disabilities.

Mills et al., 2009; Tainto M., 2010; Brook et al., 2010]. The same is true for airborne indoor particles, which have been associated with asthma, allergies, hypersensitivity and Sick Building Syndrome (SBS) [e.g. Richardson et al., 2005; McCormack et al., 2009; Norbäck, 2009]. The concern about the health impact has the last ten years been shifted towards smaller particles, not least due to the emerging field of nanotechnology. The mechanisms behind the health impact of fine (smaller than 2.5 μm , also called PM_{2.5}) and ultrafine particles (also called nano sized, having one dimension smaller than 100 nm) are not fully understood, although some examples of studies, mentioned below, provide a basis for increased theoretical understanding of exposure, uptake and kinetics. The relatively large particle number and surface area per unit mass of nano sized particles are likely to decrease the ability of the macrophages to “eat” (phagocytose) them, as well as increase their uptake by epithelial⁴ cells. Small particles can be translocated from the lungs into the blood stream or into the interstitium, i.e. the space surrounding the lung. Particles located in the interstitium may cause inflammation [Donaldson et al., 1998].

Correlation between smaller particle size and increased inflammagenicity was shown by Brown et al. [2000], who compared carbon black⁵ with ultrafine carbon black when instilled into rat lungs. It was found that the ultrafine carbon black particles induced more inflammation, probably due to increased surface area or particle number. Kreyling et al. [2002] showed translocation of radiolabeled iridium particles (15 and 80 nm) after inhalation into blood circulation, liver, spleen heart and brain in rats. The translocated fraction was one order of magnitude larger for 15 nm particles than for 80 nm particles. An inhalation study by Oberdorster et al. [2004] showed increasing particle levels of 36 nm ¹³C particles in the olfactory bulb in rats, indicating that uptake via sensory nerve endings constitutes a clearance pathway to the central nervous system. Oberdorster et al. [2011] also showed particle translocation to the cardiovascular system from the stomach and intestine of whole-body exposed rats. The cardiovascular effects of inhalation of nano-sized particles have been studied by e.g. Pekkanen et al. [2002], who could correlate exposure to ultrafine particles to ST segment depression (a feature which can be observed in the electrocardiogram (ECG) signal indicating myocardial ischemia i.e. heart attack) during exercise in human test subjects.

Indoor generated particles are of special interest since we spend a more than 85% of our lives indoors, both in our homes (65% of our time, if we live in the industrialized part of the world) and at our schools/workplaces [Leech et al., 2002; Brasche and Bischof,

⁴ Epithelium is the tissue which lines the inner surface of the trachea and bronchial parts of the lung.

⁵ Carbon black is a powder typically used as pigment in e.g. printers, or automobile tires.

2005]. Although fine particles penetrate into the interior of buildings [Morawska et al., 2001], several studies have shown that indoor generated particles often dominate the particle concentrations [Long et al., 2000; Matson, 2004; Afshari, 2005; Wallace et al., 2006]. Important indoor sources for fine and ultrafine particles include cooking, smoking, wood-combustion, heaters, burning candles, office equipment, building materials and chemical reactions in indoor air (e.g. organic vapors–ozone reactions). Several previous studies [e.g. Long et al., 2000; Wallace et al., 2006] on airborne particles of indoor origins have mainly focused on size distribution and concentration measurements, and have been performed in the field, where a number of sources are present simultaneously. Particles of outdoor and indoor origin can have significantly different physicochemical properties concerning particle diameter, solubility and chemical composition and therefore need to be considered separately. As the development of new measurement instruments is progressing, the understanding of which particle properties affect our health is increasing, and more extensive studies of aerosols and their health influence are motivated and needed.

To avoid potential risks of exposure, as well as anxiety for risks, it is of importance to develop methods and obtain data for risk assessment and for pro-active measures by engineers and designers of buildings, work environments and products.

To sum up, it is well known that airborne particles do affect our health. This is confirmed by several epidemiological studies. We also know many of the causes of elevated particle concentrations, reported in a large number of emission and exposure studies. On the basis of all this knowledge, we need to find ways of determine the links between what we inhale and how, and why, it affects us. This thesis deals with our contribution to how these questions can be dealt with.

In simple terms, we are trying to figure out what particles people really are exposed to, how much, and how we are affected by this exposure. What level of exposure occurs in real life can be assessed by studying literature and, of course, by measuring in these environments (described in Article III and Article IV). Based on this knowledge, particles of special interest can be identified. Particles can be of interest due to their size and morphology (since these are properties which influence where the particle will be deposited and how our body will take care of them) or due to that they occur in very high concentrations in environments where humans spend a large fraction of their time (at home or at workplaces). An example of morphologically interesting particles is those with a fibre structure. A very long and very thin particle can align with the airflow in the lung and be deposited in the alveoli tract. Macrophages cannot engulf such a particle because it is too long, and since it has a very small diameter, it can penetrate through the alveoli wall and end up in the interstitium of the lung and cause severe problems there. Asbestos is one example of such particle and carbon nanotubes is another. Exposure measurements of carbon nanotubes are described in Article IV. Examples of particles of special interest due to high concentrations are, in

home environments, candle smoke particles and particles generated by terpene-ozone reactions, and in work environments, welding fume particles. The former are described in Article I and the latter in Article II. All of these particles are also interesting due to their small size, they have at least one dimension which is smaller than 100 nm and can therefore be deposited deep in the lung.

To investigate if and how these particles affect us we have developed a methodology for studying health effects of airborne particles by conducting controlled human exposures. Candle smoke particles, particles generated by terpene-ozone reactions, and welding fume particles have been characterized in detail and generated in laboratory setting (described in Article I and II). Human volunteers have been exposed to these aerosols a controlled exposure chamber. The human test subjects are exposed twice, on one occasion to the aerosol in question and on another to particle free, filtered air. We work together with medical and biochemical researchers to identify physiological responses to the exposures. It can be a biochemical marker (such as an increased or decreased level of a certain protein or enzyme) or a change in heart rate variability (see Article V). The analysis of biochemical markers are best left to the medical experts, and are hence not part of this thesis. If a response is found, we could, based on the knowledge we have of the particle's properties, infer what could have caused the effect, and conduct new exposure studies using other particles which have that same property and see if the results are coherent. Eventually, this method could add to our knowledge of which types of particles are dangerous for us, and why.

In the following, before presenting the included articles, this thesis is divided into three main parts. The first part deals with how emissions and exposure have been studied, by others and by us, both in home environments and work environments. The second part deals with how particles, such as particles in candle smoke, particles from terpene-ozone reactions and particles from welding fume, can be generated in laboratory settings for being used in human exposure studies. The last part is about how these exposure studies were conducted.

2. Studies of emissions and exposures

A majority of particles in indoor and workplace environments are generated by human activities. Ambient particles generated outdoors are often assumed to be the background aerosol humans are exposed to indoors, when there is no active source present. In epidemiological studies, the outdoor particle mass concentration is often the only available exposure data.

It is well known that particles emitted from different indoor/workplace sources can have different characteristics (e.g. number concentration, size distribution, shape and chemical composition) and can be emitted at different rates. The particles generated indoors by human activities are of intermittent nature and can contribute to distinct number concentration peaks, up to more than an order of magnitude higher than the background concentration [Dennekamp et al., 2001; He et al., 2004; Wan et al., 2011]. In work place environments as well as in home environments [Hussein et al., 2006; Wallace et al., 2006; Turpin et al., 2007; Meng et al., 2009] it is foremost combustion related activities which generate high number concentrations of small (<300 nm) particles. This is a particle size range which can follow the stream of inhaled air all the way down to the alveoli tract. Therefore it is of special importance to identify and characterize those particles in indoor environments, which are not of ambient origin.

The most common metric in field studies of workplaces is mass concentration. In public environments this is often defined as mass concentration of PM₁₀, PM_{2.5} or PM₁ (particles smaller than 10 µm, 2.5 µm and 1µm, respectively). In occupational hygiene, other mass fractions defined by the American Conference of Governmental Industrial Hygienists (ACGIH), such as inhalable fraction, thoracic fraction and respirable fraction are used. It is relatively easy to measure mass concentration which is the reason for the tradition of setting health limit values in units of µg/m³. However, the smaller particles (100 or a couple of 100 nm), which are of special health interest simply due to their small size, have a small mass compared to larger particles and contribute very little to the mass concentration. Reducing the PM_{2.5} concentrations has, by the Environmental Protection Agency (USA), been demonstrated to dominate the benefits of air pollution control [Levy et al., 2012], but on the basis of both toxicologic and epidemiologic evidence, different constituents of PM_{2.5} may have different levels of toxicity [Reiss et al., 2007], which would contribute to biases in risk assessments simply based on PM_{2.5}. When measuring indoor aerosols

it is hence relevant to measure number concentration as a compliment to mass concentration.

2.1 Indoor sources

Studies conducted in USA, Canada, Finland and Germany have shown that we, in the industrialized part of the world, spend over 87 % of our time indoors, of which over 65 % is in our homes [Leech et al., 2002; Brasche and Bischof, 2005; Hussein et al., 2005]. Hereby we are, for a major part of our time, exposed to both background aerosols and aerosols emitted from indoor sources. Morawska et al. [2013] assessed that the burden of disease from indoor generated particles can reach 10-30 % of the total burden of disease from particulate matter exposure. WHO [2002] estimated that indoor air pollution causes 1.6 million premature deaths every year, worldwide, mainly due to indoor cooking (using biofuels and no active ventilation) occurring in the developing world.

Indoor environments are complex and the particle concentration is affected by several processes and factors. In absence of active indoor sources, particles indoors are the fraction of outdoor particles which have penetrated through the building envelope, or through an open window or door, and remained suspended. The outdoor contribution to the indoor aerosol size distribution is however modified compared to the distribution outdoors, due to size-specific differences in penetration efficiency [Thatcher et al., 2003; Liu and Nazaroff, 2003; Nazaroff, 2004]. Accumulation mode particles (0.1-2.5 μm) have the highest penetration [Nazaroff, 2004] since these particles are too large to be affected by diffusion and too small to be significantly affected by sedimentation or impaction. When indoor sources are present, the particle indoor/outdoor (I/O) ratio increases significantly. As an example, Morawska and Salthammer [2003] reported I/O ratios (in homes without indoor sources present) varying between 0.5 and 0.98 (for PM_{2.5}) and between 0.54 and 1.08 (for PM₁₀). With indoor sources present, the ratios were 1.14-3.91 and 1-2.4, respectively. Bhangar et al. [2011] measured I/O ratios of particle number concentration in seven homes in California, with results similar to those of Morawska and Salthammer; high I/O ratios (around 1 to up to 4) coincided with periods when the occupants were awake and at home. During non-occupancy time or when the occupants were asleep the I/O ratio was consistently below 1. As concluded by Hoek et al. [2007], and described by Wierzbicka [2008], I/O ratio also depends on the chemical composition of particles. Particles containing sulphate and soot, which are non-volatile, infiltrate to a higher degree than particles containing e.g. nitrate, which is a more volatile compound.

Indoor air particle concentration is affected by the Air Exchange Rate (AER). AER given in units of h^{-1} , and is a measurement of how many air volumes per hour by which a room, apartment, or building, is ventilated. In homes, AER can vary quite substantially, and in our work (described in detail in Article III) AER estimations based on 15 homes ranged between 0.3 and 2.9 h^{-1} . Bhangar et al. [2011] reported values between 0.18 and 1.1 h^{-1} in 7 homes, and in a more extensive study (2844 homes) a geometric mean AER of 0.5 h^{-1} with geometric standard deviation 2.1 h^{-1} was reported [Murray and Burmaster, 1995; Nazaroff, 2004]. The air exchange rate is associated with the ability of particles to infiltrate from outdoors and persist indoors, in that a higher AER increases the levels of outdoor particles present indoors [Bhangar et al., 2011]. The Swedish National Board of Health and Welfare recommends a minimum air exchange rate of 0.5 h^{-1} in residential dwellings. With a low air exchange rate, the impact of indoor sources on the total particle concentration will be more pronounced, and the prolonged residence time will also provide more time for processes such as coagulation (when particles, providing sufficiently high concentrations, collide due to Brownian motion, adhere to each other and form larger particles) and chemical reactions (such as the formation of secondary organic aerosols by reactions between organic gases and ozone).

Indoors, particles are being deposited on available surfaces by the same mechanisms that govern particle deposition outdoors; particles smaller than 100 nm are deposited by diffusion and particles larger than 1 μm mainly by sedimentation due to gravity. Particles in the accumulation mode have the lowest deposition, since they are not significantly affected by either of these two mechanisms. The deposition rate depends not only on particle size but also on factors such as surface area available for deposition and airflows.

Once deposited on a surface the particles can later be resuspended by activities such as walking, dusting or sweeping. This is particularly pronounced for the coarse mode particles (shown by e.g. Abt et al. [2000] and Long et al. [2000]). Particles deposited by diffusion tend to adhere strongly to the surface of deposition due to van der Waal⁶ forces.

⁶ The van der Waal force is caused by temporary electrical dipoles that emerge due to continuous variations in the electron configuration in all materials. It is strong, but have a very short range of action.

2.1.1 Air measurements in residential dwellings

Several studies have been conducted in residential dwellings. In an extensive review by Morawska et al. [2013] of such studies, it was concluded that indoor sources periodically generate particles that significantly exceed background number and mass concentrations [Abt et al., 2000; Long et al., 2000; He et al., 2004]. Indoor sources of ultrafine particles were e.g. tobacco smoking, cooking, candles, incense, photocopiers, printers and terpene containing products such as cleaning agents, air fresheners and furniture polish. Sources of larger particles were e.g. sweeping, dusting, human movement, resuspension from clothes, washing powder residue and resuspension from carpets (see references in Morawska et al. [2013]).

Monitoring of these particles in indoor environments is generally done either by online techniques (time-resolved instruments) or by off-line techniques (filter sampling and subsequent analysis), or by a combination of both. Particle concentration data can, together with information on the residents' activity time and time spent at home, give an estimation of the personal exposure. Bhangar et al. [2011], Mullen et al. [2011] and Wallace and Ott [2011] presented a normalized form of integrated exposure of ultrafine particles; residential daily integrated exposure, which is calculated in units of particles per $\text{cm}^3 \cdot \text{h/day}$. The average indoor residential daily integrated exposure from these three studies were $1.15 \cdot 10^5$ to $2.96 \cdot 10^5$ particles/ $\text{cm}^3 \cdot \text{h/day}$ [Morawska et al., 2013].

2.1.1.1 Indoor generated particles and residential exposure

Based on the abovementioned, we conducted a study (described in detail in Article III), where weeklong time-resolved particle concentration measurements were carried out in randomly selected homes in Lund, Sweden. From 22 of these homes, it was possible to estimate an average indoor residential daily integrated exposure of particles smaller than 300 nm of $4 \cdot 10^5$ particles/ $\text{cm}^3 \cdot \text{h/day}$, ranging between $8 \cdot 10^4$ and $1.5 \cdot 10^6$ particles/ $\text{cm}^3 \cdot \text{h/day}$. This is somewhat higher than the average of the three studies mentioned above, which could be related to that our measurements were conducted during wintertime, when it is common in Sweden to burn candles at home. The large variation of residential daily integrated exposure is in concordance with a study by Bekö et al. [2013] where the residential daily integrated exposure of particles smaller than 300 nm ranged between $3.7 \cdot 10^4$ and $6.0 \cdot 10^5$ particles/ $\text{cm}^3 \cdot \text{h/day}$. Of the residential daily integrated exposure calculated in our study, the

contribution from known activities was $2.7 \cdot 10^5$ particles/cm³ · h/day (66%), from unknown activities $1.1 \cdot 10^5$ particles/cm³ · h/d (20%), and from background/non-activity $0.4 \cdot 10^5$ particles/cm³ · h/day (14%).

That indoors generated particles periodically amount to concentrations significantly exceeding outdoor concentrations was also confirmed by our study. We studied the frequency at which a given concentration of particles smaller than 300 nm occur indoors as compared to outdoors by plotting the normalized (due to differences in time resolution between indoor instrument and outdoor instrument) frequency of a given concentration to occur (y-axis) as a function of concentrations (x-axis). In Figure 1 it is clearly shown that during periods of non-activity, the concentrations indoors are similar to those outdoors, and that concentrations above 10^4 almost exclusively is reached when residents are at home and active.

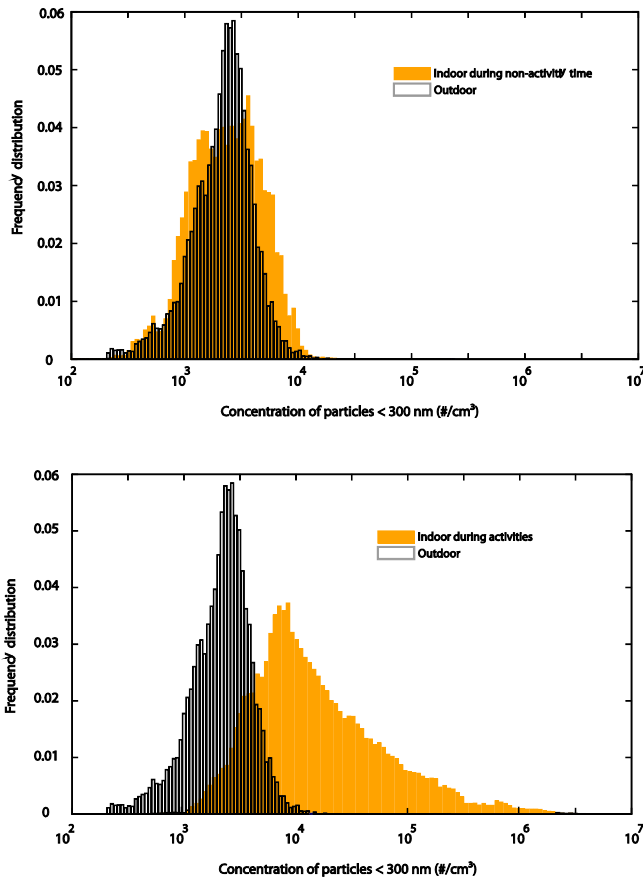

Figure 1. Occurrence of particle (<300 nm) number concentrations outdoor (transparent) and indoors (orange) during non-activity time (above) and activity time (below).

2.1.2 Candle smoke

Candles have been identified as significant sources of ultra-fine particles indoors [Matson, 2005; Hussein et al., 2006; Wierzbicka et al. 2008; Bekö et al., 2013] and a major contributor to indoor soot (elemental carbon (EC)) as well as to PM_{2.5} concentrations [Larosa et al., 2002; Sorensen et al., 2005].

A candle flame is approximately a diffusion flame, with the wax being the fuel, which is transported by the wick by capillary forces. The oxidant, air, is transported by convection vertically along the flame. Large quantities of soot particles can be formed in the flame regions where there is a lot of fuel. The yellow/orange light making up a majority of the flame is this soot oxidizing. During steady burn, in principle all of the soot will be oxidized, resulting in very low soot emissions. During this mode of burning, high number concentrations of ultrafine, around 20 nm [Zai et al., 2006] nucleation mode particles are formed. Pagels et al. [2009] showed that these particles mainly consist of soluble alkali phosphates and nitrates originating from flame retardant additives to the wick. If air in the vicinity of the flame is moving, e.g. due to an open window or people gesticulating, the flame will start to flicker and soot will be able to escape without being oxidized. These soot particles are of health interest due to their small size (100 -300 nm) and because of their active surface, which attracts gases and other particle phase toxins. An additional potential health problem related to candle burning is the occurrence and release of metal additives from the wick and color pigments from the wax.

Glytsos et al. [2010] studied how the size distribution of smoke from one candle (type not specified) changed with time when burning for an 80 minute period in a 60 m³ laboratory room (air exchange rate not specified). They found that the total particle number rose quickly and remained almost constant while the PM_{2.5} mass concentration continued to increase throughout the period. At the beginning of the period the emission of particles smaller than 50 nm represented more than 85% of the total particles. With time, the size distribution shifted from a unimodal to a bimodal distribution, which is explained by coagulation between the high amounts of very small particles. It is not discussed if the larger size mode (around 200-300 nm) could be due to soot as well.

There is difference in particle emissions between different types of candles. Pagels et al. [2009] showed that a paraffin/stearin candle had significantly higher soot emissions than a more expensive candle made of pure stearin. In that study, candles were burned in a well-controlled chamber and during sooting burn, when the flames were unshielded and made to flicker due to air movements from a fan, the concentration of soot in the chamber air increased by more than 5000%. In the chamber, which is similar to a small room with relatively low air exchange rate, mass concentrations up

to 2 mg/m³ were measured when four candles of the paraffin/stearin type were burned. The aerosol generated by the candles was bi-modal, consisting of a smaller, primary particle nucleation mode (particle diameter 25-30 nm) and a soot mode of particles around 270 nm. The nucleation mode particles make up the major part of the number concentration.

2.1.3 Particles generated by terpene-ozone reactions

Volatile organic compounds (VOCs) can react with indoor ozone and form secondary organic aerosols (SOAs). Several sources of unsaturated VOCs can be found indoors, for example woods, carpets, paints, cleaning products, polishes, air fresheners and perfumes [Liu et al., 2004; Weschler, 2006; Singer et al., 2006]. Terpenes, in particular limonene and pinene, are common constituents of commercial cleaning products and are among the unsaturated VOCs most frequently encountered in indoor environments [Fiedler et al., 2005; Youssefi and Waring, 2012]. For example limonene is often added to cleaning products in the form of lemon oil to give the room a fresh scent when cleaning, but can also, along with other VOCs, be emitted from paint [Lamorena et al., 2007].

Ozone is present in indoor air by infiltration from outdoors with ventilation air. Ozone levels indoors are typically 20-70% of concurrent outdoor levels [Weschler, 2000] Ozone is also generated by sources indoors, such as photocopiers and laser printers [Weschler, 2000; Lee et al., 2001] and certain air cleaners [Britigan et al., 2006]. Indoor ozone concentrations vary depending on several factors, e.g. outdoor levels, ventilation, time of day and time of year. Zhang and Lioy [1993] reported average concentrations of 28-60 ppb.

Ozone-terpene reaction dynamics are extremely complex [Carlaw et al., 2009], and a wide range of products are created. If these chemical reactions will occur or not is determined by the time available for reaction, which mainly depends on two factors: the ventilation rate and the dry deposition rate of the reactants [Langer et al., 2008]. Limonene, which possesses two unsaturated carbon-carbon bonds, is rapidly oxidized in the presence of ozone and forms stable, irritating end products. Among these are high vapor pressure products in the gas-phase such as formaldehyde [Atkinson and Arey, 2003; Weschler, 2011; Wolkoff et al., 2012] and lower vapor pressure products. The low vapor pressure products form SOAs, both by homogenous nucleation of ultrafine particles or through condensation on existing particles [Wainman et al., 2000; Destailats et al., 2006; Weschler, 2006; Wescher, 2011]. In addition to stable oxidation products, terpene ozonolysis is a major source of indoor radicals, including OH, Criegee Intermediates and other organic radicals [Weschler and Shields, 1997; Atkinson and Arey, 2003], which are suspected to cause eye and airway irritation [Klenø and Wolkoff, 2004].

The reaction of ozone with various terpenes in indoor settings has been showed to contribute tens of micrograms per cubic meter to the indoor concentration of submicrometer particles [Destailats et al., 2006]. Vartiainen et al. [2006] found limonene oxidation to be a strong source of indoor particles. They added limonene to a laboratory room by peeling two oranges, which resulted in a significant increase of number concentration of particles as small as 3 nm, quickly followed by condensational growth, with growth rates as high as several hundred nanometers per hour. The use of terpene containing cleaning products have been shown to result in peak particle mass concentrations of the magnitude of mg/m^3 in indoor air and levels up to tenths- to hundreds of $\mu\text{g}/\text{m}^3$ can be maintained for several hours after a cleaning event [Long et al., 2000; Singer et al., 2006].

The high amount of ultrafine particles which are formed during terpene-ozone reactions might pose a health problem in itself. Additionally, it is likely that these particles can serve as carriers for some of the more volatile reaction products, and exposure to such products may be of concern to human health [Weschler, 2004]. Several products of ozone-initiated chemistry are anticipated to exacerbate asthma [Leikauf, 2002], Limonene-ozone reaction products have been shown to be eye irritants [Klenø and Wolkoff, 2004; Klenø-Nøjgaard et al., 2005]. Sherriff et al. [2005] and Medina-Ramon et al. [2006] points to the reaction products of terpenes in cleaning products and ozone as a potential course of adverse health effects. A review about the health significance of terpene oxidation products [Rohr, 2013], it was concluded that high concentrations of the gas-phase oxidation products have a clear role in adverse airway effects, but that the evidence for toxicity of particle-phase oxidation products is less conclusive. Further studies of the toxicology and health effects of terpene-ozone reaction products are needed, as pointed out by Carslaw et al. [2009].

2.2 Workplace sources

The study of workplace exposure dates back to the 18th century and to Bernadino Ramazzini, called the father of occupational medicine. His book *De Morbis Artificum Diatriba* (Diseases of workers), first edition published 1700 and second 1713, defined the health hazards of dust, metals, chemicals and other harmful agents encountered by workers in over 50 occupations [Cockayne, 2007]. Today, it is in many ways more difficult to estimate the risk of different exposures, due to the increased number of potentially harmful agents and new materials and methods [Bohgard et al., 2008]. Clean air is one of the foundations of a healthy and productive work life, however, potentially harmful exposure to airborne particles is a reality in many professions. To create good existing working environments and prevent new

upcoming industries of being harmful for their employees, workplace air measurements can contribute with much needed knowledge.

2.2.1 Strategies for workplace measurements

The two main purposes of conducting workplace measurements are to assess what a worker is exposed to (exposure measurement) and to identify and quantify sources of emissions (emission measurement). Exposure measurements can be carried out with the purpose of comparison with occupational health limit values, but also for investigating relationships with various medical conditions in epidemiological studies. The sampling should be done in the breathing zone, i.e. within a distance of 0.3 m from mouth/nose [AFS 2011:18], a criteria which normally requires portable measurement equipment. It is common to use a combination of filter sampling equipment (for gravimetric and chemical analysis) and direct-reading instruments together with activity logs (for time resolution). The sampled amount on a filter for gravimetric analysis must be large enough for detection down to a value of one tenth of the health limits in question [Krook, 2006]. The measurement duration must be long enough so that comparisons can be made to the time weighted average threshold limit value of the substance/aerosol of interest. Emission measurements conducted in the direct vicinity of the source can reveal how much each process/activity contributes to the aerosol concentration, and can be used as a basis for elimination strategies in the workplace environment. The emission strength can be estimated from such measurements, if air movements are stable.

When it comes to particles smaller than, or around, 100 nm, such as welding fume or engineered nanoparticles, it can be a considerable problem to distinguish the nanoparticles of interest from the background aerosol. The two most common strategies to handle this are the time series approach and the spatial approach. The time series approach assumes that the concentration determined during no work activity is the background concentration and an increased concentration during activity can be attributed to particles from the work process. Monitoring is conducted before and after the activity at the location of the workstation/source [Brouwer et al., 2009]. The spatial approach assumes that a background measurement location is representative for the background. Any difference between this background and workplace concentrations is then linked to the work activity and the nanoparticles investigated. Often a combination of the two approaches is used. See Kuhlbusch et al. [2011] for an extensive account on the subject of background measurements.

2.2.2 Welding fume

The art of joining metals dates as far back as the Bronze Age, and throughout times a large variety of welding methods have been developed. Among the most common industrial methods today is GMAW (Gas Metal Arc Welding). The GMAW process uses automatized and continuous electrode wire feed and an inert or active shielding gas. The GMAW welding method is often referred to as MIG (Metal Inert Gas) or MAG (Metal Active Gas) depending on the composition of the shielding gas; carbon dioxide is an active gas, while e.g. argon and helium are inactive. The purpose of the shielding gas is to protect the molten metal from oxidation. The composition of the electrode is mainly determined by the composition of the substrate. Arc welding causes around 10 % of the consumable welding electrode to vaporize [Jenkins, 2003]. Most of the vapor will recondense in the weld pool, but approximately one tenth of it travels out of the high-temperature arc region and condenses into metal oxide nanoparticles that aggregate into submicron clusters [Jenkins, 2003], with mean size around 100-200 nm [Zimmer et al., 2002; Jenkins, 2003]. The agglomerates consist of a various number of primary particles, which are of different sizes (Figure 2) depending on at which temperature they were formed [Antonini, 2003]. The composition of the welding fume is reasonably independent of the welding substrate; almost all of the species found in the fume can be derived from the electrode material [Antonini et al., 2006]. The substrate only seems to influence the fume composition if it is covered with oil, paint or similar substances [Quimby & Ulrich, 1999].

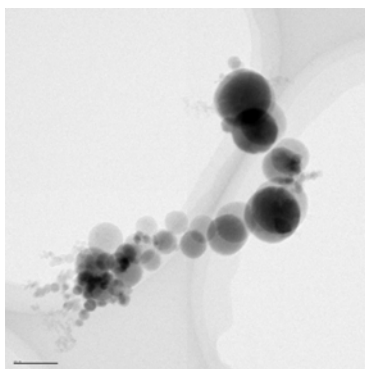

Figure 2. Transmission Electron Microscopy (TEM) image of welding fume particle generated by GMAW. Size-bar is 100 nm. Image by Maria Messing.

Welding is a major source of fine and ultrafine particles in working environments worldwide. In the United States alone, there are nearly 0.5 million people performing welding and cutting operations full-time, and an additional 1–2 million workers who weld intermittently [Jenkins, 2003]. In Europe, 0.8 million people work as full-time welders and 1 million more weld intermittently [Hedlund, 2011]. The total amount of fume emitted from the welding industry worldwide is estimated to 5000 tons/year [Redding 2002]. Directly above the arc, particle mass concentration is very high; 100–400 mg/m³. The concentration in the breathing zone varies, but levels as high as 5 mg/m³ are typical throughout the industry [Zimmer & Biswas, 2001]. Furthermore, particles from welding processes are enriched with metal oxides, which are potentially toxic.

2.2.2.1 Characteristics of welding fume aerosol investigated in three Swedish workshops

To study the emission and exposure characteristics of welding aerosols, with focus om GMAW welding in mild⁷ steel, three welding workshops in southern Sweden were visited [Isaxon et al., 2008]. This knowledge was used to generate relevant welding fume for controlled human exposures in our chamber (see chapter 3.3).

Background PM10 measurements were conducted at 2 m height, at least 5 m distant from the nearest known source of fine and ultrafine particles. The second sampling point was in a freshly generated welding plume at a distance 5–20 cm above the welding point using a sampling probe immediately connected to a two stage ejector dilution system. These emission measurements provided us with the signature size distribution and composition of welding fumes.

To estimate personal particle exposure, selected welders carried personal filter samplers incorporating respirable fraction cyclone pre-collectors. Relative humidity and temperature were also monitored.

The PM10 measurements in the background ranged from < 100 µg/m³ during longer breaks, up to 3000 µg/m³ during intense activities. Personal exposures ranged from 600–3400 µg/m³ respirable dust. The signature number size distributions from welding typically yielded a single mode with geometric mean aerodynamic diameter of 100–150 nm and a mass mean aerodynamic diameter of 200–300 nm.

⁷ Mild steel is steel containing less than 0.15% carbon. It is the most commonly used type of steel.

In Figure 3a, an example is given of the elemental composition (health relevant and major elements) for in-plume measurements of MAG-welding in mild steel. The particle composition is dominated by iron, with a manganese fraction which increases with size. As expected from mild-steel welding, the fraction of nickel and chromium is very low.

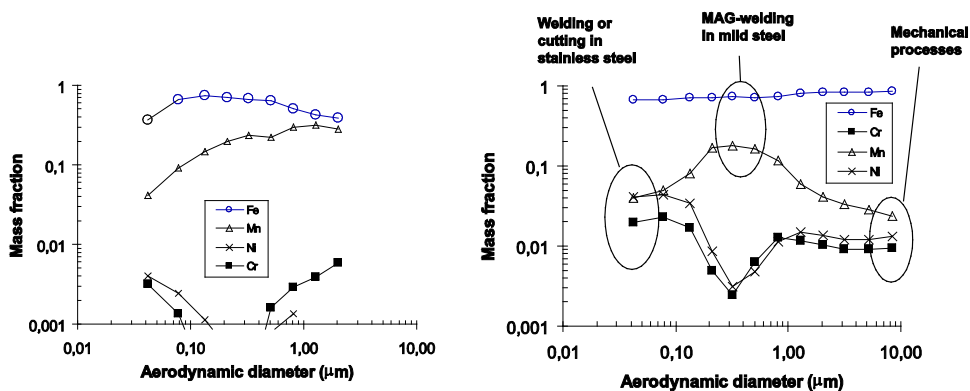

Figure 3. Elemental composition of welding fume in plume (3a) and of background air in welding workshop (3b).

In Figure 3b, an example of the background air chemical composition in the same workshop is given. The fraction of Ni and Cr is about an order of magnitude higher as compared to the elemental composition of mild steel welding in figure 3a. This is due to work in stainless steel elsewhere in the workshop. The fraction of these compounds is especially elevated for particles smaller than 150 nm, which either indicates that welding in stainless steel generates smaller particles, or that another operation in stainless steel, for example cutting, is dominating in this size range. Between 150 and 500 nm, the fractions of Fe and Mn are approximately the same, and the Ni and Cr concentrations are low. This suggests that MAG welding in mild steel is the main contributor for these sizes in the background aerosol. The fraction of Mn decreases towards a few percent for coarse particles, which is in the same fraction range as the raw material (mild steel), indicating an aerosol which is being generated by mechanical processes elsewhere in the workshop (as opposed to the evaporation-condensation processes which are responsible for the fine mode). Above 300 nm, the fractions of Ni and Cr increases with increasing particle size, which could indicate the presence of mechanical processes in stainless steel as well.

A representative example of the large time fluctuations of background particle number and mass concentrations can be seen in Figure 4. Activities, mainly welding, increase the exposure both in terms of number and mass by more than an order of magnitude, from less than $100 \mu\text{g}/\text{m}^3$ during longer breaks up to $3000 \mu\text{g}/\text{m}^3$ during intense periods.

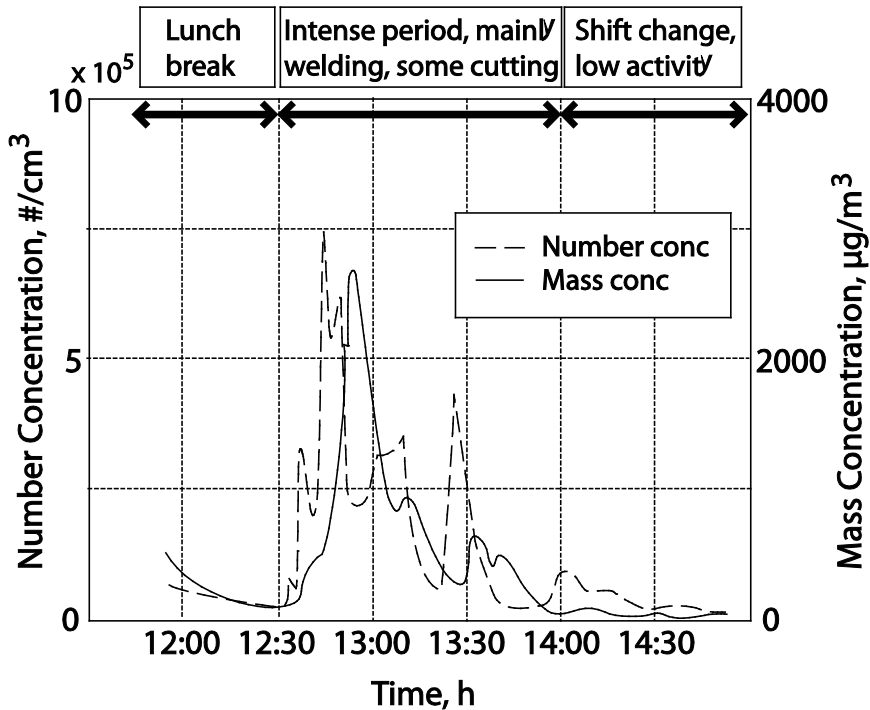

Figure 4. Number and mass concentrations during one afternoon at one of the three welding workshops.

2.2.3 Manufactured nano objects

The upcoming technology of Manufactured Nano Objects (MNOs) (also often referred to as Engineered Nano Particles, ENPs) is a field of research and production filled with visions and hopes of contributing to a better future. MNOs are not a specific type of compound, but rather a way to categorize a wide variety of

compounds based on size⁸. All MNOs have properties distinctly different from those of the bulk material due to that surface effects and quantum effect increases with decreasing size. The physical and chemical properties of a specific MNO can depend on a variety of factors, such as chemical composition, size, shape, surface-to-volume ratio, magnetic properties, surface charge, and coating. Also, the same type of MNO can often be produced in different processes, which can result in different physical and chemical, and potentially toxically, properties [Forsberg, 2013]. Today, a lot of knowledge is missing concerning both the possible toxicological effects of MNOs and the exposure for humans and environment. In the field of Nanosafety, researchers work on increasing our understanding on how MNOs affect humans and environment in production, handling, usage, disposal and recycling, so that tools for proactivity in the development of new MNOs can be provided.

One type of new MNO is nanofibers, for example carbon nanotubes, which are used for their good mechanical, electrical and chemical properties. Carbon nanotubes have nanoscaled size in two dimensions, i.e. they have structural similarities to asbestos fibres.

2.2.3.1 Carbon nanotubes

When Harald Kroto and his team at Rice University, Texas, discovered the spherical buckminsterfullerene carbon molecule in 1985, the interest in new forms of carbon, with unique properties, had its starting point and has increased dramatically since. Carbon nanotubes (CNTs) have gained a special interest, and today the fields of application are several. When incorporated in products, as composite materials and fabrics, CNTs can improve properties like durability, strength, flexibility, and conductivity. Today, the development of new technologies using CNTs is mainly restricted by the limited ability of manufacturers to produce large quantities of well characterized quality [Maynard et al., 2004]. The increasing demand of CNTs means increased handling and, inevitably, increased risk of exposure, both of workers and of the general public. CNTs are high aspect ratio particles (i.e. fibre-like) with low density, high surface-to-mass ratio and biopersistent, all of which are properties interesting from a health point-of-view. The similarities with asbestos are apparent, and against that background the need of a proactive approach to the potential risks is indisputable, as pointed out by e.g. Sanchez et al. [2009] and Donaldson et al. [2011].

⁸ There is yet no worldwide agreed on definition. EU-OSHA have suggested: An MNO (or ENP) is a particle with a nominal diameter - such as geometric, aerodynamic, mobility, projected-area or otherwise - smaller than 100 nm, intentionally engineered and produced with specific properties.

Considerable efforts have been, and are being, made to examining the potential occupational exposure by inhalation and toxicological effects of manufactured nano objects. No toxicological data for humans concerning CNTs, exist as of today, but animal inhalation studies have shown effects in the lungs, such as inflammation [Grecco et al., 2011; Tkach et al., 2011], granuloma⁹ formation and fibrosis¹⁰ [Pauluhn, 2010; Porter et al., 2012].

The major part of CNT emission and exposure measurements has been made in facilities where the nanotubes are produced by chemical vapor deposition (CVD) [Maynard et al., 2004; Moisala et al., 2005; Bello et al., 2008; Han et al., 2008; Methner et al., 2009; Lee et al., 2010]. The technique is based on thermal decomposition of a hydrocarbon vapor in presence of a metal catalyst. Because of its low set-up cost, high production yield, purity and scalability, this technique is the most widely used [Kumar and Ando, 2010]. Another method for CNT generation is the laser vaporization technique [Guo et al., 1995], where pulses from a high intensity laser are used for vaporization of a graphite target. Emissions from this technique have been studied by e.g. Methner et al. [2009] and Dewalle et al. [2010]. The technique first used when discovering CNTs [Iijima, 1991] was, however, the arc-discharge technique. This technique is based on two graphite electrodes in a reactor with an inert gas atmosphere, typically helium. When a voltage is applied over the electrodes, CNTs form on the cathode while the anode is consumed [Gamaly and Ebbesen, 1995]. This is a cheap way of producing high-quality CNTs without the use of metallic catalysts, the draw-back is a high amount of graphite impurities. The arc-discharge is the least studied CNT producing technique when it comes to emissions and exposure, and to our knowledge, there are no studies thereof. Yenageh et al. [2008] studied airborne particles when the arc-discharge technique was employed to produce fullerenes and found elevated carbonaceous particle number concentrations close to the reactor.

There is an ongoing debate considering what metric is most relevant for the exposure of manufactured nano objects. In addition to number concentration; mass, size, shape, surface area and composition are examples of parameters, which can be assumed to influence particle toxicity [Warheit, 2007; Trout and Schulte, 2010]. As long as the research society has not agreed upon what dose-metric best correlates with toxicological effects, it is of importance to use a study design that includes measuring several different characteristics, such as mass concentration, elemental carbon (EC) concentration and number concentration of CNT-containing particles [Dahm et al., 2012; Brouwer et al., 2012; Hedmer et al., 2013]. As of today, there exists no consensus

⁹ Granuloma is an organized collection of macrophages causing an inflammation.

¹⁰ Fibrosis is lung scarring; a formation of excess fibrous tissue in an organ.

concerning occupational exposure limits for CNTs. An exposure limit to high length-to-width ratio fibrous nanomaterials of 0.01 fibre/cm^3 have been proposed by the British Standards Institute and the Institute for Occupational Safety and Health of the German Social Accident Insurance [BSI, 2007; IFA, 2009]. The Japanese New Energy and Industrial Technology Department Organization has proposed a mass based exposure limit of $30 \mu\text{g/m}^3$ [Nakanishi et al., 2011]. Occupational exposure limits of CNTs could also be expressed as mass concentration of EC. The National Institute of Occupational Safety and Health (NIOSH) suggested $1 \mu\text{g EC/m}^3$ as a respirable 8-hour-time-weighted average concentration limit. It is also highly relevant to make both measurements during a full work-day, for comparison with suggested benchmark exposure limits, and task-based measurements, to identify in which process steps emissions, and hence exposure risk, occur. NIOSH has suggested a Nanoparticle Emission Assessment Technique (NEAT), based on a combination of direct-reading instrumentation and filter-based air samples, both source-specific and in the personal breathing zone [Methner et al., 2010]. By analyzing the filters using electron microscopy it is possible to access morphology, chemical composition, and number concentration of CNT-containing particles; information that cannot be obtained from particle number concentration or size distributions alone. This approach can make it possible to differentiate between ambient and process-related nanoparticles.

Based on the similarities between CNTs and asbestos fibres, some workplace exposure studies [Bello et al., 2009; Lee et al., 2010] have employed the WHO [1997] standard method for fibre counting (in which a fibre is counted if it has a minimum length of $5 \mu\text{m}$, a width less than $3 \mu\text{m}$, and a length-to-width ratio of more than 3:1). By this method, neither of these studies quantified any, or only a few, CNTs.

2.2.3.2 Exposure and emission measurements at a CNT producing facility

We performed exposure and emission measurements (described in detail in Article IV) at a small scale producer of multi-walled CNTs. In this facility, CNTs are produced by the arc-discharge method, and sold as either “as produced” or as purified and functionalized. Purification and functionalization was conducted at the same facility, but in a laboratory on a floor separate from that of the production. The exposure measurements were conducted in the worker’s breathing zone; with filter-based methods the respirable fractions of dust, EC concentrations and number concentrations of CNT containing particles were assessed. Portable, direct-reading instruments were used to measure respirable number- and mass concentrations of particles. Respirable dust (particles smaller than $4 \mu\text{m}$) was gravimetrically determined; EC was analyzed with thermal–optical analysis and the number of CNT-containing particles was analyzed with scanning electron microscopy. Since most airborne CNTs do not have the typical fibre dimensions defined by WHO [1997]

due to agglomeration [Schulte et al., 2012], we counted every CNT containing particle regardless of length. From a health perspective, this quantification is also justified, since it is not clarified what happens to agglomerated CNTs when deposited in lung lining fluid.

The respirable dust in this study ranged between less than 73 and up to 93 $\mu\text{g}/\text{m}^3$, EC ranged between less than 0.08 and up to 2.0 $\mu\text{g}/\text{m}^3$ and the number concentration of CNT containing particles ranged between 0.04 and 2.0 cm^{-3} . The highest exposures were measured during production, especially during sieving, mechanical work-up, pouring, weighing and packing. Furthermore was also found that the CNT-containing particles could be classified into four categories (examples shown in Figure 5). Type a consist of fibre shaped CNTs, with one or several tubes stuck in parallel to each other with no, or very low, amount of impurities. In the production room, on average 39% of the CNT containing particles were of this type. Type b contains one or more CNTs sticking out from a lump of impurities of which the diameter is smaller or roughly equal to the length of the tubes sticking out from it (22% in the production room). Type c particles are clusters with diameters 10-100 μm , containing a high amount of entangled CNTs (10% in the production room). Finally, type d have an amount of impurities which is high compared to the CNT content, with CNTs only visible embedded at the surface or slightly sticking out. On average, in the production lab, 29% was of this type.

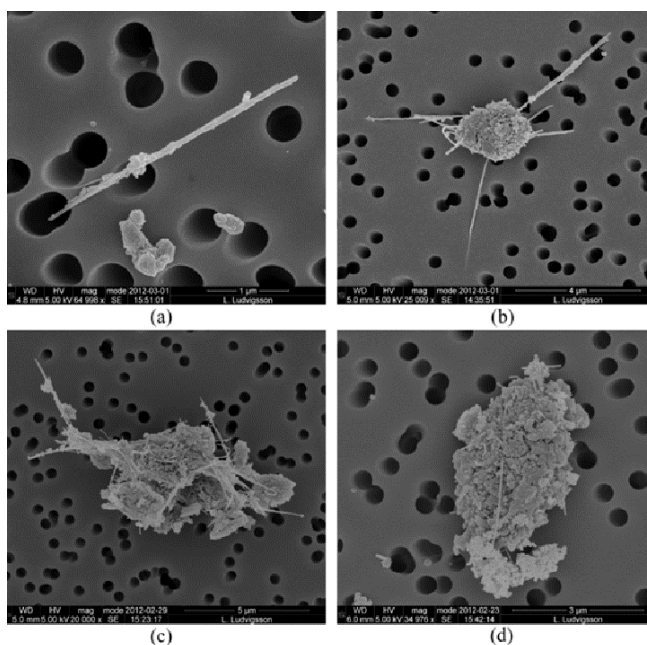

Figure 5. The four different types of CNT containing particles. TEM image by Linus Ludvigsson.

3. Particle generation and characterization for exposure studies

Achieving a well-controlled aerosol for exposure studies, with high demands of specific concentration and particle size distribution, require well planned generation systems. If the aim is to study health effects of exposure to particles sources in the surrounding air, these sources firstly need to be identified and characterized, in terms of e.g. concentration, size distribution and chemical composition. Furthermore, such a source needs to be generated in a laboratory setting, including more thorough characterization to ensure its resemblance to the real life aerosol. In our human exposure studies, we want to achieve concentrations high enough to ensure that if there is a physiological effect, its signal is seen, but low enough to not exceed a realistic concentration and to not make our human test subjects sick. Target concentrations can be higher than normal indoor concentrations, since the exposure time is relatively short (3 h or 5h in our exposure studies) compared to every day indoor exposure. Once this is achieved, reproducibility must be ensured. Finally, the aerosol must be delivered into the exposure chamber with a minimum of residence time in the system, to ensure that no undesired aerosol dynamic processes, such as coagulation, occur. Few studies have been published where the generation system is optimized for double blind¹¹ exposure of humans, and in most cases the generation is made for characterization purposes only, or for animal inhalation studies (where the double blind criteria as such does not apply). When the generated aerosol is to be used for human exposures, the generation system must be separate from the exposure chamber so that it is not visible for the subjects in the chamber, nor for the medical staff. The system delivering the aerosol from the generation chamber to the exposure chamber should not be noisy or in any other way revealing if an aerosol is being delivered or not.

Not many particle generations for human exposure studies are reported in the literature. A study similar to ours was reported by Salvi et al. [1999], Stenfors et al.

¹¹ In a double blind exposure study neither the human test subjects nor the medical staff is informed (or should be able to figure out) if the exposure consists of clean air or a particle source.

[2004], and Sehlstedt [2010a] where diesel exhaust generated using an idling engine and after dilution delivered the aerosol to human subjects in an exposure chamber. The exposure situation was blinded only to the test subjects. In other human exposure studies [Huang et al., 2003; Gong et al., 2003; Gong et al., 2005; Brook et al., 2009; Sivagangabalan et al., 2011], aerosols have been produced with a high-flow virtual impactor system, using concentrated ambient fine particles (CAP) from outside the laboratory building in question. Sehlstedt et al. [2010b] generated wood smoke for human exposures using a pellets burner and delivered the diluted aerosol to the exposure chamber in a double blind fashion.

In our studies, we have developed systems for generating candle smoke, particles from terpene-ozone reactions and welding fume.

3.1 Candle smoke generation

In the literature, generation of candle smoke has mainly been performed for aerosol characterization purposes, and some different approaches have been suggested. Shooto and Diko [2011] generated candle smoke and sampled it in a fume hood, Lee and Wang [2006] generated in an environmental chamber with well controlled ventilation, Orecchio [2011] generated in a real room and Glytsos et al. [2010] in a laboratory room. The generation volumes range from smaller/medium [Zai et al., 2006; Derudi et al., 2012 and 2013; Petry et al., 2013] to larger [Afshari et al., 2005; Lee and Wang, 2006; Pagels et al., 2009]. Common for the studies is that the candles were placed in the same volume as the aerosol sampling was conducted from, except for Stabile et al., [2012], who placed the candle on the floor of a room and channeled the smoke by natural convection through a vertical duct in a 0.25 m^3 chamber from where the sampling was done.

An issue in candle smoke generation is the simulation of realistic burning conditions, since the type, and size, of particles produced are inherently connected to burning mode (as discussed in chapter 2.1.2). From experience, it seems most likely that in the real world, a candle does not burn steady all the time, or flicker constantly, but rather a bit of both. Based on literature studies and laboratory experiments, we developed a generation system for human exposure studies of candle smoke, which is described in detail in Article I. By using a rotating fan in the generation volume the flame was made to alternate between flickering, hence producing soot particles, and burning in a steady mode, hence producing ultrafine nucleation particles. In comparison (Figure 6) to the size distributions presented by Pagels et al. [2009], from a steady burn event and of an event when a candle burned with a flickering flame, it can be verified that the candle smoke for exposure studies was generated by a mixture of both burning modes. The resulting aerosol was bimodal, with a mode of nucleation particles in the size range of 15 nm, and a soot mode with particles around 200 nm.

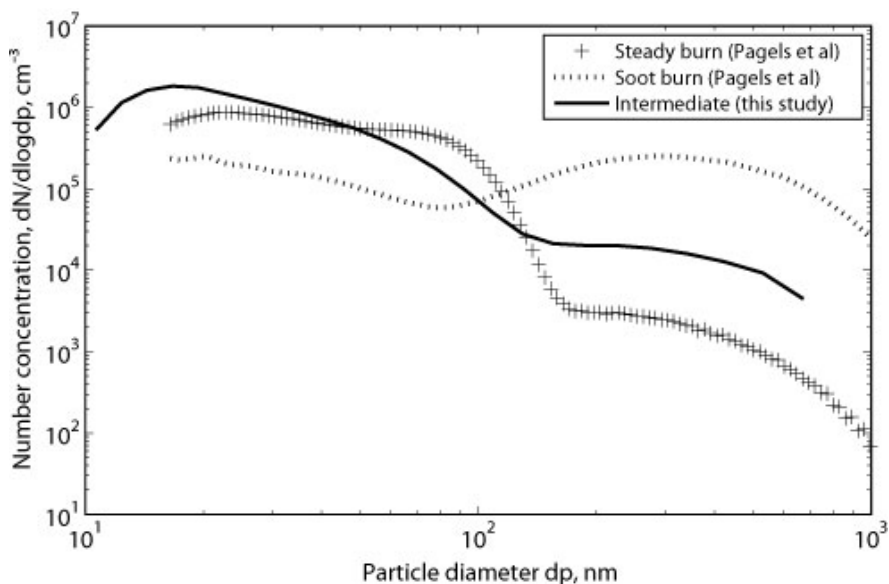

Figure 6. Size distribution of candle smoke aerosol generated for human exposure studies compared to size distribution from steady burn and sooting burn.

The mean mass concentration was $200 \mu\text{g}/\text{m}^3$, and the mean number concentration was $8 \cdot 10^5 \text{ cm}^{-3}$. To verify that this concentration is in agreement with real-life candle smoke exposure in home environment, a simple box model [Koutrakis et al., 1991] was applied for estimating the mass emission factor for the generated candle smoke. This result was then compared to mass emission factors calculated by Pagels et al. [2009] for steady and sooting burn respectively. It was found that our mass concentration during the exposure events corresponds to 2 hours steady burn of 12-18 candles or 2 hours sooting burn of 1-4 candles.

The reproducibility of the generation method can be verified by plotting the size distribution from all six candle exposure events in the same graph (Figure 7).

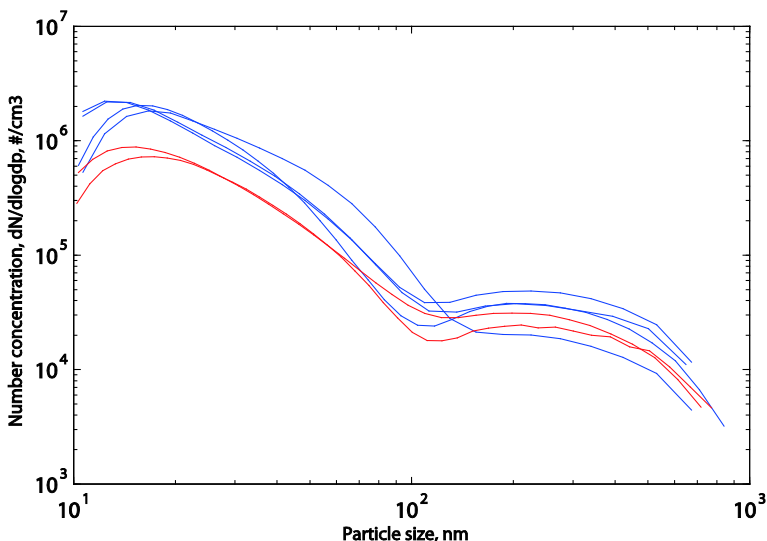

Figure 7. Size distributions from the six candle exposure events. During the events represented by the two red graphs, which slightly deviates from the rest, there were initial problems with the extractor hood in the generation volume.

3.2 Generation of particles from terpene-ozone reactions

Experimentally, terpene-ozone particles can be generated by reactions of ozone with either commercial products containing terpenes, or with pure terpenes (e.g. limonene or pinene). Singer et al. [2006] used commercially available cleaning products and generated particles by cleaning different surfaces in a controlled chamber. Cleaning products were applied realistically with quantities scaled to simulate residential use rates. Prior to application of the cleaning products, ozone concentration in the chamber was 60 ppb. Cleaning product used in the presence of ozone generated substantial fine particle concentrations, of more than $100 \mu\text{g}/\text{m}^3$. Liu et al. [2004] used a 30 m^3 stainless steel chamber in which air freshener emissions were allowed to react with ozone. Four pine-scented air fresheners were placed in the chamber for 24 h before ozone generation was turned on. After 72 or 120 h the fresheners were removed, and monitoring continued for another 24 h. Immediately after supplying of ozone, formation of ultrafine particles in high numbers was observed. During the time of the experiment, particle diameter increased and number concentrations decreased. The average mass concentration of particles was gravimetrically determined to $40\text{-}50 \mu\text{g}/\text{m}^3$.

Rohr et al. [2003] introduced ozone and different pure gas phase terpenes into a reaction flow tube. From this, the reaction products entered a plexiglass chamber from which particle measurements were made. The gas phase terpenes were generated by allowing compressed nitrogen pass through a bottle of terpene solution. Fan et al [2003] studied reaction products between ozone and a mixture of 23 VOCs in a 25 m³ controlled environmental chamber. Ozone was introduced into the chamber prior to the VOC mixture. A syringe pump was used to deliver the VOC mixture to a heated flask. The chemicals in the flask were then flash evaporated and delivered to the chamber by a clean airstream which was mixed with the main airstream before entering the chamber. Chen and Hopke [2010] used pure limonene delivered by a modified impinger to a 2.5 m³ stainless steel chamber where ozone had been introduced. Sarwar and Corsi [2007] conducted experiments with pure limonene in a 11 m³ stainless steel chamber. Ozone was first introduced, and when steady state was achieved, a vial with pure limonene was placed on the floor in the chamber.

For our human exposure studies, particles from terpene-ozone reactions were generated by passing pure nitrogen through a glass bottle containing limonene. The bottle was placed behind a screen in the immediate vicinity of the exposure chamber. Just prior to being delivered into the exposure chamber, ozone was added to the air-and-VOC flow. Ozone was the limiting agent, and very low ozone levels remained after reaction. The generation (described in detail in Article I) resulted in a single mode aerosol, with mean diameter 95-105 nm. The average number and mass concentrations were $3 \cdot 10^4 \text{ cm}^{-3}$ and $80 \text{ }\mu\text{g/m}^3$, respectively. During the 3 h generation, assuming a person breathes 8 l/min, a human test subject would be exposed to 100 mg of particles generated by terpene-ozone reactions. This should be compared to Nazaroff et al. [2006], where it was found that during moderate outdoor ozone levels, a person doing their normal day-to-day house cleaning will inhale an average of 35 mg/day of SOAs, mainly as ultrafine particles, as a consequence of ozone reacting with constituents of the cleaning agents.

With the described system, a reproducible aerosol could be generated (Figure 8) and used for human exposure studies.

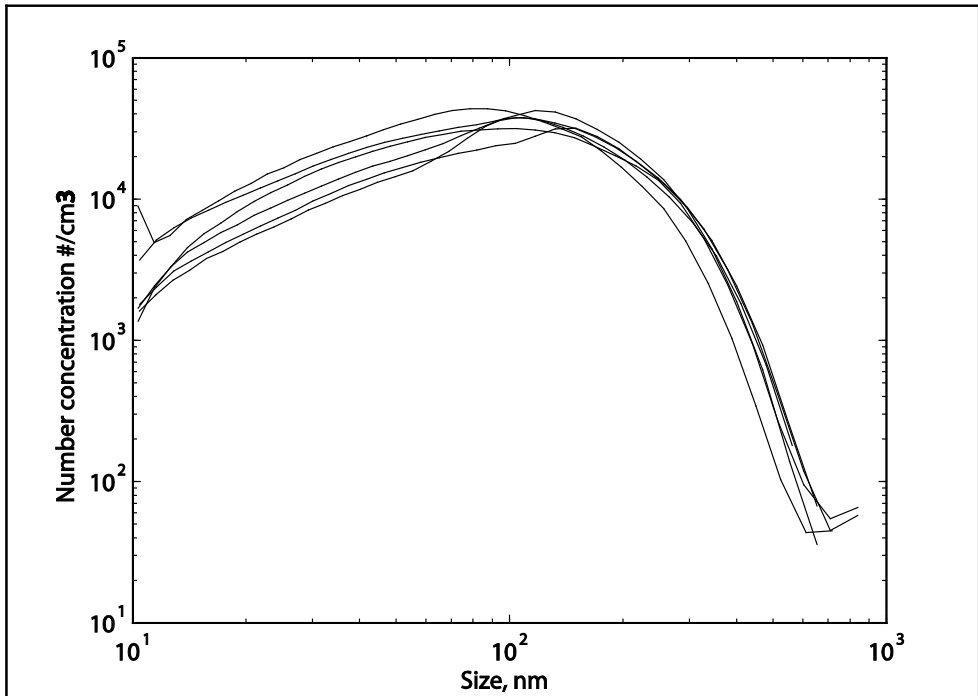

Figure 8. Size distributions from all six human exposure studies of particles generated by terpene-ozone reactions.

3.3 Welding fume generation

The toxicology of welding fume is often studied using animal models in specialized laboratories. In these cases it is common that the welding fume is generated by an automatized/robotic system, such as the semi-automatic rotating drum system described by Yu et al. [2000] and [2001] or the NIOSH welding fume generator described by for example Antonini et al. [2006]. By using an automatized welding system, reproducibility is ensured, and the welding will be carried out without unwanted variations. Welding fume can be generated at constant concentrations over extended periods of time. However, robotic welding systems are of course costly to develop and maintain, and if a realistic welding exposure is the aim, constant concentrations are not in agreement with reality. For human exposure studies disciplined welding conducted by a trained human may be more relevant.

In this work, welding for human exposure studies was performed on a substrate of mild steel moving the nozzle in straight lines at a steady speed, and care was taken not

to let a new welding joint cross an old one. A trained welder was present during the initial phase when the method was established and the welding equipment settings chosen. A welding pulse of 3 minutes was followed by a non-welding period of 10-15 minutes and constant monitoring with TEOM and SMPS ensured that the target exposure concentrations were reached. The generation system is described in detail in Article II. The generation resulted in a size distribution with a mean diameter of 160 nm, resembling the size distribution of MAG welding fume studied at the welding workshops (Figure 9).

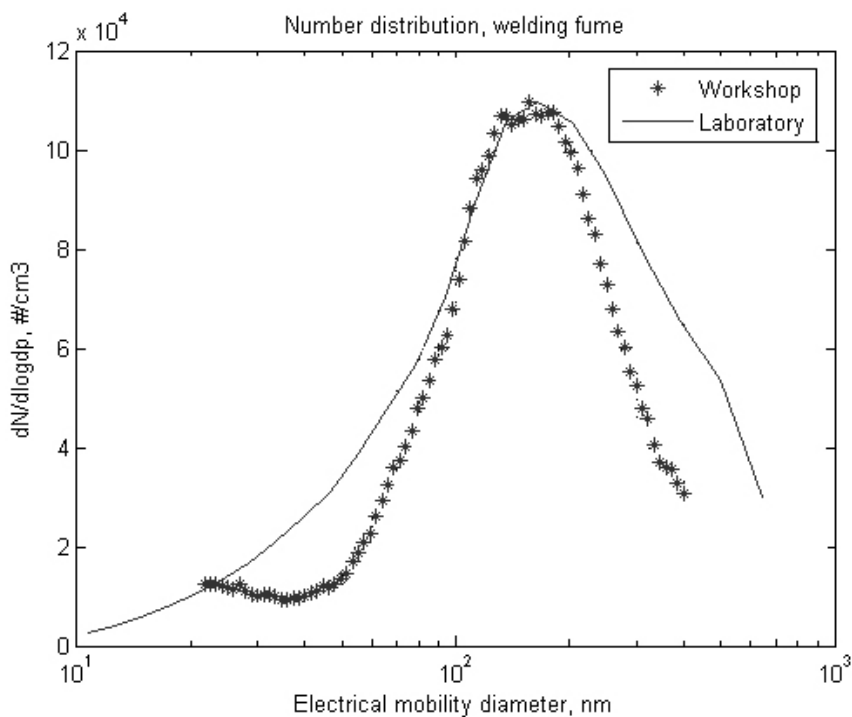

Figure 9. MAG welding number size distribution from laboratory and welding workshop. Workshop data has been normalized to fit the maximum value of the chamber concentration.

Based on the Swedish occupational health limit value of manganese ($100 \mu\text{g}/\text{m}^3$ for an 8 h period), the target concentration was set to $1000 \mu\text{g}/\text{m}^3$. The average mass and number concentrations during the 6 h exposure events were $1000 \pm 70 \mu\text{g}/\text{m}^3$ and $6.4 \cdot 10^4 \pm 1.5 \cdot 10^4 \text{ cm}^{-3}$, respectively. With this system, a reproducible welding fume could be generated in the human exposure events, as shown in Figure 10. The generation volume and system for delivering the welding fume to the exposure chamber was the same as for candle smoke.

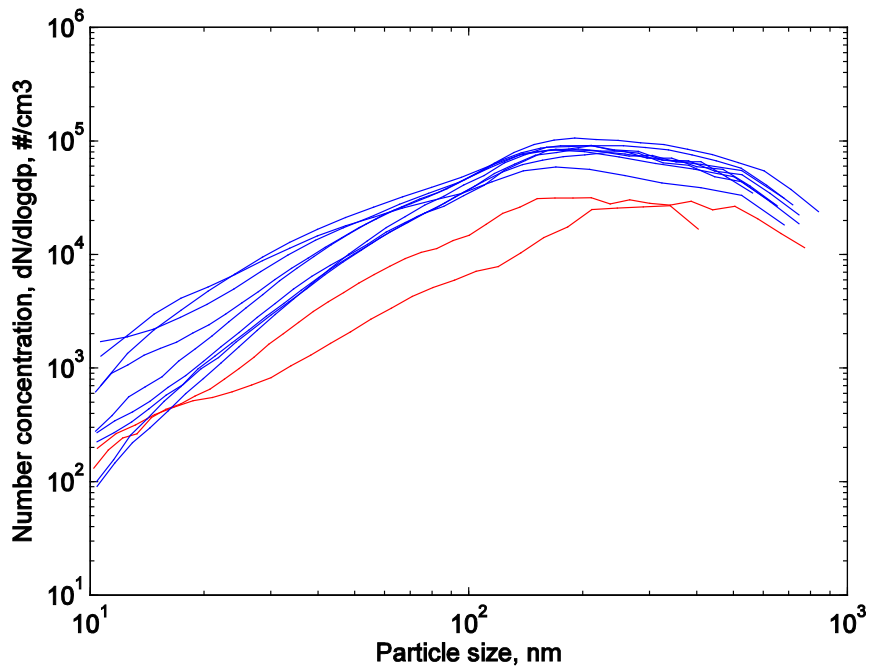

Figure 10. Size distributions for welding fume during the different exposure events. The two distributions marked in red are from exposure events when the welding system electrode feed malfunctioned in short periods. (Note, logarithmic scale compared to linear in figure 9.)

4. Human exposure studies

Most of our general knowledge of health impact of particles comes from toxicological studies (in animals and cells) and from epidemiological studies based on measurements of outdoor particles.

Using laboratory animals may initially be helpful in studies of acute effects of particle exposure. In this kind of studies, very high concentrations can be used to provoke effects, but due to differences in size, metabolism, breathing pattern etc. it is not straight forward to translate the results to the human physiology. It is therefore of interest to directly investigate how human health is affected by the surrounding air, using relevant particle concentrations and common particle types. Studies have shown inflammatory airway responses in healthy humans exposed to wood smoke and to diesel exhaust in exposure chamber settings [Salvi et al., 1999; Stenfors 2004; Sehlstedt et al., 2010]. By generating, in a controlled way, relevant concentrations of indoor and workplace aerosols for human exposure studies we aim to investigate a wider range of particle properties and search for markers of exposure, on DNA level, cell level, biochemically, and in heart rate variability. If such markers are identified, they can later be used for assessing human exposure in work (or other) environments.

4.1 Exposure chamber

The human exposure chamber (Figure 11), used in several articles in this thesis, is a 21.6 m³ room where all interior surfaces except for a single window of 0.8 m² are made out of stainless steel. No air can enter or leave the chamber except through its well-controlled ventilation system. The room is entered via an antechamber (3.1 m³) with air tight doors both to the chamber and to the surrounding laboratory. The seals of the inner door are expanded by pressurized air. The air supplied to the antechamber is exhaust air from the chamber itself, which minimizes contamination of the chamber air when entering or leaving. The exposure chamber is supplied with air through a separate, custom-built, conditioning system by which air flow, temperature and relative humidity is controlled and adjusted. After being filtered inside the conditioning system, the chamber air supply passes through an additional

set of filters: an activated carbon filter and an ULPA¹² filter, before entering the exposure chamber at roof level. The exposure aerosol, and (in the case of terpene-ozone) aerosol forming precursors, are pre-mixed with the supply air and passed into the clean air stream just above the chamber inlet at roof level. The air supply opening into the chamber is 250 mm in diameter. Two variable iris modules are used to determine the clean and the aerosol-laden flow rates, respectively, through pressure drop measurements.



Figure 11. The stainless steel exposure chamber at Lund University.

The chamber air exhaust is situated at 0.8 m height at the diagonally opposite corner of the air inlet. The exhaust flow is controlled using a variable exhaust fan. This fan is also utilized for achieving a desired slight over- or under-pressure inside the chamber compared to the surroundings. This is done to make sure no particles from the

¹² Ultra Low Penetration Air filter. Removes at least 99.999% of airborne particles 0.12 μm or larger.

surrounding air penetrate into the chamber (over pressure) or that no exposure aerosol leaks out (under pressure). This pressure difference is determined and monitored using a u-tube. An over-pressure in the chamber is typically set to 10 Pa or just below. The chamber can be quickly emptied of remaining aerosols after an experiment with the help of an express fan. In this case air is supplied from the surrounding room, passed through a filter with pelleted active carbon and through a HEPA¹³ filter before entering the chamber at high flow rate. The express system provides an air exchange rate of $\sim 15 \text{ h}^{-1}$, and in 15-20 min the particle concentration is down to 1 % of the initial concentration. The ventilation system on the chamber roof is shown in Figure 12.

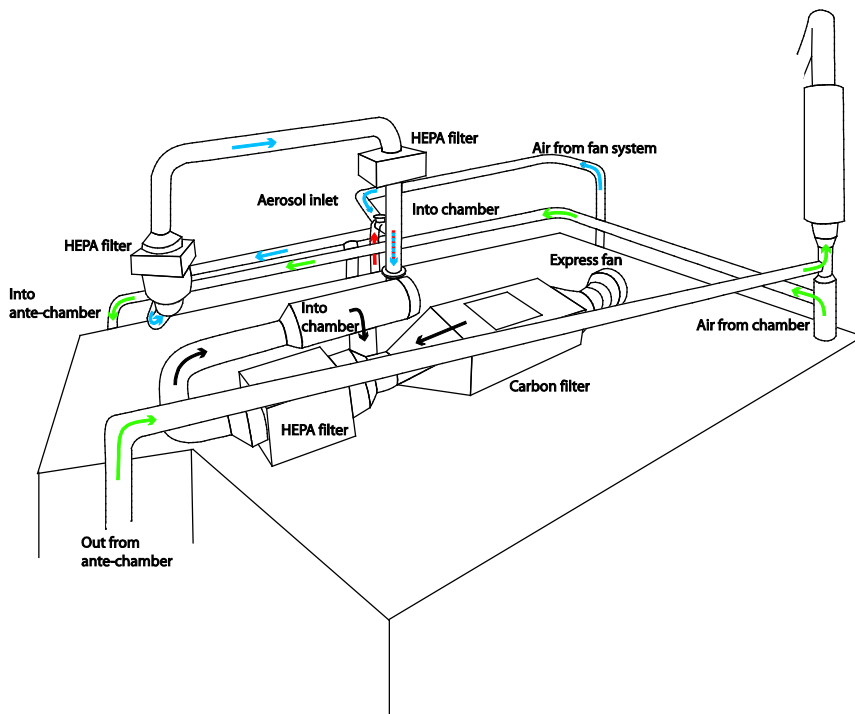

Figure 12. The chamber air supply system. Blue arrows denote supply air originating from the conditioning unit. Green arrows denote exhaust air originating from the chamber. Red arrow denotes generated aerosol, black arrows denote express fan air flow.

¹³ High-Efficiency Particulate Absorption filter. Removes at least 99.97% of airborne particles 0.3 μm or larger.

A series of experiments using trace gas measurements were conducted to calibrate the air exchange rates as a function of fan settings in the conditioning unit, and to investigate the degree of complete mixing in the chamber. With the conditioning system the exposure chamber can be set to air exchange rates up to 4.5 h^{-1} . In the case of candle smoke generation, the air amplifier adds 500 l/min to the air flow from the conditioning system, resulting in an air exchange rate of 5.8 h^{-1} . Inside the chamber it is possible to use a mobile rotating fan to quickly achieve complete mixing, preferentially when low air exchange rates are being employed. The trace gas measurements are used as reference to validate the variable iris modules, which are used to monitor the air exchange rate during the exposure events. The trace gas measurements showed that in the absence of test subjects, at air exchange rates of around 4 h^{-1} , concentration gradients are less than 15% throughout the chamber volume. In the presence of test subjects, the degree of mixing improves due to the thermal convection induced by the test subjects. An air exchange rate of 4.5 h^{-1} was found to be needed to maintain a comfortable CO_2 level when three test subjects at rest were in the chamber. Since the test subjects spent their time in the chamber sitting down and relaxing, a temperature of approximately $23 \text{ }^\circ\text{C}$ was needed for them to feel comfortable. The conditioning system was started well ahead of exposure starting time, to ensure steady state.

4.2 Study design

The indoor particle exposure study population consisted of 20 healthy adult females, aged between 18 and 62 years. Of the 20 participants, 13 were exposed to both candle smoke particles and particles from terpene-ozone reactions (at separate occasions), 4 only participated in candle smoke exposure and 3 only in exposure of particles generated by terpene-ozone reactions.

The welding exposure study population consisted of 11 male welders with work related symptoms from the lower airways, 10 male welders without symptoms and 11 male subjects without exposure to welding fume and without symptoms. Welders without symptoms were matched as well as possible the symptomatic ones with regard to company, total welding time, age and atopy¹⁴. The non-welding control subjects were employed in a storeroom in one of the welding factories and in another mechanical industry without exposure to welding.

¹⁴ Atopy is a genetic predisposition toward the development of immediate hypersensitivity reactions against common environmental antigens.

None of the participants had been smokers for at least five years, and they were not allowed to take medicines that affected the heart rhythm, anti-inflammatory drugs including steroids or antihistamines.

The participants of the welding study were exposed during two separate Mondays in the exposure chamber, to welding fume or to virtually particle free air in a double blind manner. The exposure time was 6 hours each time with a lunch break for 1 hour. The welders had not been exposed to welding fume for at least 48 hours prior to the challenge.

The female test subjects participating in the indoor particle exposure study were exposed during three separate Wednesdays in the exposure chamber, to candle smoke, to particles generated by terpene-ozone reactions or to virtually particle free air in a double blind manner. The indoor particle exposure duration was 3 hours.

4.3 Medical examinations and biochemical markers

Before the study all participants underwent a basic medical examination, to exclude test subjects with allergy or potential heart problems. The participants went through another medical examination including lung auscultation, spirometry and acoustic rhinometry just before and after the exposure. Symptoms, such as irritation in throat or dryness in eyes were reported by the test subjects during exposure, and Peak expiratory flow (PEF) were registered, before, during and after the exposure. To study biochemical markers, nasal lavage, urine and blood samples were obtained before and after the exposure and, if practically possible, also after 24 hours. Furthermore, exhaled air condensate was sampled before and after the exposure. Some of the biochemical markers investigated are albumin (a blood plasma protein), cytokines (a category of signaling molecules), and ICAM-1 (proteins that recruits white blood cells). All collection of substances for analysis of biochemical markers are non-invasive and easy to conduct.

The results of the medical examinations and biochemical markers analysis is not part of this thesis and will be presented elsewhere.

4.4 Heart Rate Variability

Several studies have shown correlation between exposure to airborne particles and cardiovascular problems [Brook et al., 2010; Nawroot et al., 2011; Weichenthal 2012]. Heart rate variability is a well-recognized noninvasive method for cardiovascular risk prediction [Malik, 1996]. The beat-to-beat variation of the heart is part of how the autonomous nerve system regulates the cardiovascular system, both when it comes to how often the sinoatrial node tells the hart to beat and how strong these beats should be. The autonomous nervous system is often talked about in terms of two components; Parasympaticus, which has a decelerating effect on the sinoatrial node, and sympaticus, which has an accelerating effect. The heart frequency is constituted by the balance between these two components. The parasympathic system, which is dominant when a person is in a state of rest, can make quick fine adjustments of the occurrence of the upcoming heartbeat, whilst the sympathetic system is slower in its actions [Hagerman et al., 1996]. The major part of the heart rate variability is constituted by how the respiratory system influences the parasympathic component of the autonomous nervous system.

The heart frequency variations in healthy individuals are not random, but consist of certain rhythms that reflect how the autonomous nerve system controls the blood circulation. In Heart Rate Variability (HRV) analysis, the variation in the RR-intervals (as shown in Figure 13) in a series of heart beats is studied.

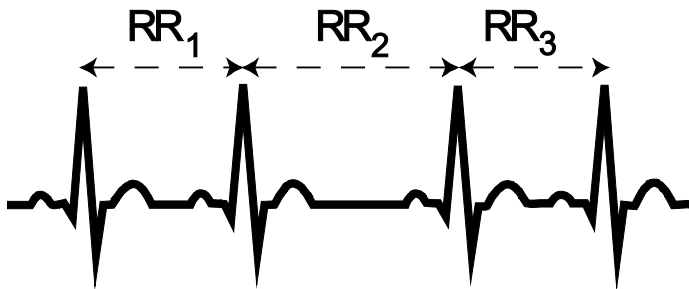

Figure 13. RR-intervals in a series of heart beats.

HRV analysis can be performed by a variety of methods; the most common is the frequency-domain, where the effect spectrum is calculated by fast Fourier Transform of the ECG signal. The frequency-domain method reveals how the variability effect is allocated to the different frequency components in the signal. The effect corresponds to the square of the component's amplitude. The effect spectrum is divided into different frequency domains, as shown in Figure 14, based on the rhythms the HRV signal is expected to reflect:

1) High frequency (HF) variations (0.15 – 0.50 Hz). These variations are connected with the breathing pattern and represent parasympathic modulation of the heart frequency.

2) Low frequency (LF) variations (0.05 – 0.15 Hz). The variations in this domain are connected with the blood pressure and represent a combination of parasympathic and sympathetic modulation.

Two more frequency components exist; very low frequency (VLF) and ultra-low frequency (ULF). These are less commonly used due to that the needed length of the time series is more than 10 minutes.

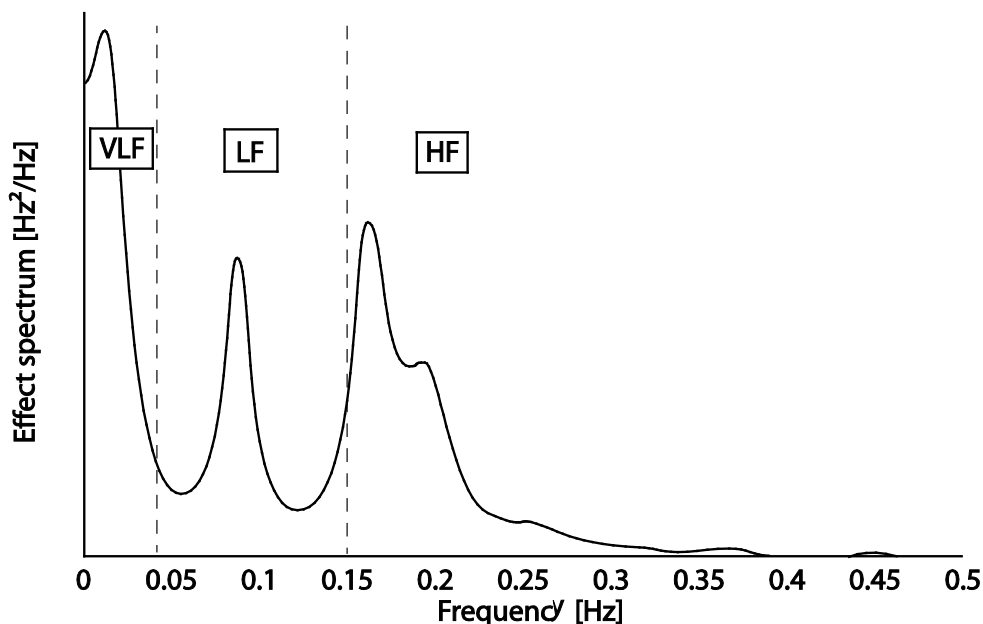

Figure 14. Effect spectrum, with very low frequency, low frequency and high frequency domains marked.

There is quite a large variation in HRV in between individuals, depending on factors such as age, breathing frequency, mean heart frequency and time of day. The heart

frequency variability decreases with increasing age. If a patient/test subject have a HRV much higher than expected it can be due to extra heart beats or other rhythm disorder, however it is generally “good” to have a high HRV, and it is when the variability is lower than expected various health disorders can be suspected. Examples of such disorders can be coronary disease, heart attack, cardiac insufficiency or diabetes, just to mention a few.

The fact that the respiratory system has a large influence on HRV, and that the autonomic nervous system has properties to detect inflammatory stimuli [Huston and Tracey, 2011], makes HRV interesting as a potential marker of exposure.

Prior to the ECG registration in our exposure studies, the human test subjects had to be at rest for 10 min, and were not allowed to have eaten a big meal, smoked or had coffee (which are factors that could have an influence on HRV) during a few hours before the event. 10 minute ECG series were collected at 3 occasions during the indoor particles exposure and at 5 occasions during the welding exposures. The first time series of each exposure were collected in the chamber before the actual exposure starts. This first time series serve as a baseline measurement, with which the following measurements were compared (each human test subject was hence his/her own control).

The HF was the primary endpoint for analysis, since the major part of HRV consists of alterations in this respiratory dependent frequency domain, but LF was also studied, and the LF/HF (autonomic balance) ratio. For these two domains, and for the LF/HF ratio, percentage changes from baseline were calculated for each individual and each exposure scenario. All results were statistically adjusted for age.

In our study (described in detail in Article V), exposure to candle smoke increased HF by 22% ($p=0.01$) compared to baseline exposure, which indicate a shift towards a more parasympathetic tone. Exposure to particles generated by terpene-ozone reactions, on the other hand, tended to decrease HF by 7%, but not significantly ($p=0.41$). The difference between the changes in HF during candle exposure and during exposure for particles generated by terpene-ozone reactions was 28.9% ($p=0.02$), which suggests that ultrafine particles with different characteristics affect the HRV differently. LF/HF tended to decrease during candle smoke exposure and increase during exposure to particles generated by terpene-ozone reactions. There was quite a large inter-individual variability in the HRV measurements, which may be explained by other factors influencing HRV, such as hormones and vascular endothelial function.

5. Instruments and analysis methods

Laboratory instruments

Scanning Mobility Particle Sizer (SMPS)

An SMPS (Scanning Mobility Particle Sizer) system measures the size distribution of sub micrometer aerosols using an electrical mobility separation technique, with optical particle detection. The main components of the systems are the DMA (Differential Mobility Analyzer) and the CPC (Condensation Particle Counter).

A bipolar charger – also called neutralizer – exposes the aerosol particles to high concentrations of bipolar ions, thus giving the particles a bipolar equilibrium charge distribution. The polydisperse, charged aerosol passes into an electrostatic classifier, which consists of two concentric metal cylinders over which an electric field is applied. Depending on the particle electrical mobility (and on flow rate and geometry of the construction) the particle will end up somewhere along the inner rod, or be just within that narrow range of electrical mobilities which exit through a small slit at the end of the inner rod. When the voltage of the electric field is varied, particles with different electrical mobility exit exactly at the slot, thus applying a voltage ramp from, for example, 20 to 10 000 volts, will render a size distribution covering the major part of most aerosols from combustion or other chemical processes. Once the particles are classified according to electrical mobility, their concentration is measured by a CPC. In the CPC, alcohol condensate onto the particles which makes them grow to a size large enough for optical detection with a diode laser.

Tapered Element Oscillating Microbalance (TEOM)

The TEOM (Rupprecht & Patashnick Co. Inc.) is a continuous, filter-based method for aerosol mass measurements. The tapered element is hollow, made of glass and oscillates at its eigenfrequency (figure 4.9). A filter is placed on top of the element. When the sample flow passes the filter, particulate matter is deposited, causing the weight of the filter to increase and hence the oscillation frequency to decrease proportionally to the increase of filter mass. The sample flow passes through the

hollow element to an active volumetric flow control and a vacuum pump, to maintain constant flow, making it possible to translate frequencies to particle mass concentrations.

Portable field instruments

Nanotracer and DiSCMini

These instruments are based on an electrical measurement technique, with a diffusion charger followed by electrometers that measure the current carried by charged particles. The current is converted to number concentration and the mean diameter is estimated. The accuracy of both the Nanotracer and DiSC are $\pm 30\%$ [Asbach et al., 2012].

Lighthouse

The Lighthouse is an optical particle counter, Indoor Air Quality monitor (IAQ3016, Lighthouse) and works on the principle that particles passing a laser beam inside the instrument scatter light. The scattered light is detected by a photo detector, which converts the light to an electrical pulse. For a single particle, the height of the generated pulse depends on the size, refractive index and color of the particle. According to a reference aerosol of monodisperse PSL particles, the pulse height is transferred to six particle size intervals. The particle number concentration is given for the particle size channels: 0.3, 0.5, 1.0, 2.5, 5.0 and 10 μm .

microAeth

The soot monitor measures the transmission of infrared (IR) light (880 nm) through a filter, which is continuously loaded with airborne particles by the suction of an internal pump. The accumulation of particles on the filter over time increases the absorbance, which is calculated relative to a reference cell. The attenuation IR is then transferred to mass concentration of black carbon (described in detail by Cheng and Lin [2013]).

Aerosol analysis methods

Particle Induced X-ray Emission (PIXE)

PIXE is a method for analyzing elemental composition, in which a focused proton beam of 2.55 MeV creates a vacancy in an inner electron shell of an atom, which put the atom in a state of high excitation. A transition to a state of lower energy quickly occurs when an electron from an outer shell falls into the vacancy to fill the hole. The electron hole can thus be seen as moving outwards to outer shells and a series of emission lines, corresponding to the successive atomic energy losses, is obtained. The cross section for the creation of an inner shell vacancy is very high using protons and therefore the sensitivity is high – most elements except the very light ones ($Z < 14$) can be detected in concentrations below 1 ppb.

Organic carbon / Elemental Carbon (OC/EC)

OC/EC is a method to determine the organic and inorganic carbon content of a sampled aerosol. The air is first led through a cyclone that removes particulate matter larger than 1 μm , (95 % of soot and welding fume particles are smaller than this) then led through two parallel lines whose flow rate are controlled by needle valves. In one of the lines a quartz filter is placed which collects carbon in both particle- and some gas phases. Since the purpose is to gain knowledge of the carbon contents of the particles, only the second line has a Teflon filter upstream of a quartz filter. The Teflon filter collects all particulate matter leaving only carbon in gas phase to be collected on the quartz filter. By subtracting the back-up quartz filter from the first quartz filter the total particulate carbon is obtained. In the analysis following the collection procedure, the elemental carbon in the particles is separated from the organic carbon.

High Resolution Time-of-Flight Aerosol Mass Spectrometer (HR-ToF-AMS)

The HR-ToF-AMS consists of three main parts: aerodynamic lens, sizing region and mass spectrometer. The inlet with the aerodynamic lens focuses particles over a wide size range (from around 50 nm to 1000 nm) to a narrow beam, here they will be accelerated due to vacuum and the velocity they gain is proportional to their vacuum aerodynamic diameter. A rotating chopper is placed at the entrance of the sizing region to modulate the particle beam by “chopping” it at a specific frequency. By detecting the time of flight of the particles from the chopper to a heated surface (at the end of the sizing region), the aerodynamic vacuum diameter can be determined. At the heated surface, the particles are vaporized and ionized before entering the mass spectrometer. The mass analysis is done by measuring the ion time of flight and detecting the ionized fragments by their mass-to-charge ratio.

Gas Chromatography – Mass spectrometry (GC-MS)

The GC-MS is composed by a gas chromatograph and a mass spectrometer. The gas chromatograph system uses a capillary column with a “stationary phase”, i.e. a microscopic layer of or polymer inside a glass or metal column. The difference in chemical properties between different molecules in the aerosol and the molecules’ relative affinity for the stationary phase of the column will promote separation of the molecules as the aerosol sample travels the length of the column. The result is that the molecules come off the column at different times, which allows for a mass spectrometer to capture, ionize, accelerate and detect the ionized molecules separately.

6. Summary and outlook

Epidemiology reveals connections between exposure and effects, but is a blunt instrument when it comes to clarify which particle properties (such as concentration, or the size, shape or chemical composition) causes these effects. Human exposure studies have the potential to relate observable effects to the characteristics of the aerosol. Only a few human exposure studies reported in the literature are performed under controlled forms, to one well-defined aerosol at a time. In this thesis a methodology for conducting such studies is presented. Advanced studies like these are expensive, logistically difficult and demand competence from several different fields of science, but they have potential of generating very interesting results.

Several decisions have to be made when designing such a study. A target particle concentration has to be set. It has to be realistic, but not too low, so that a potential effect is not missed, and not too high with respect to ethical considerations and occupational thresholds limits. In the case of candle smoke, it was decided on a concentration which would resemble realistic indoor conditions in Swedish homes, based on our measurements. In the case of welding fume, the concentrations were based on our measurements in welding workshops, and on the Swedish occupational health limit value for manganese. To optimize the chances of understanding the causality (what caused the effect), it is desirable to have few potential causes to deal with, meaning that in an ideal exposure situation as few parameters as possible are preferable. Take the case of candle smoke, for example. Probably you are more likely to see an effect if you use a candle which does not only contain pure stearin but is colored and scented and is burning fiercely, generating a lot of soot. However, if there then is an effect, it will be more difficult to know exactly what caused it. By studying people in a controlled environment, such as the exposure chamber, we minimize the number of parameters. If these kinds of studies were conducted in real world environments, the multitude of possible parameters would make the interpretation of results very complex, if not impossible.

HRV measurements can be used to obtain information of physiological responses of exposure to particles of different concentrations, sizes and chemical composition, and can contribute to the understanding of mechanisms behind health effects of airborne particles. The HRV methodology has the advantages of being non-invasive, and not expensive, exposure time can be short and can be performed at particle concentrations that are far below applicable hygienic thresholds limits.

Another limitation in epidemiology is the difficulty to assess the actual exposure. Exposure data in epidemiological studies is often collected from one single measurement point, outdoors. To assess the actual exposure, measurements have to be made in the breathing zone of every participant, which would be very costly in large epidemiological studies. Studies of emissions and exposure in different environments can contribute to the knowledge of what true personal exposure is, and this could later be used in epidemiology. Additionally, in such studies, a first characterization of particles can be made, which can serve as a decision basis for what further characterization needs to be made in laboratory settings. A detailed characterization will increase our knowledge of those particle properties that have potential to be health relevant. Thorough characterization of particle properties is necessary in order to be able to reproduce them later, to perform more adequate health-relevant measurement (e.g. human chamber exposures). Characterization is also necessary in order to assess particle health effects on the basis of toxicity, if known, or if human studies cannot be performed. As an example, detailed characterization of the properties of potentially hazardous particles (such as carbon nanotubes) can be a way to estimate toxicity, which is needed since that type of particles cannot, because of ethical considerations, be used for human studies.

In this thesis, a method is described for quantifying the number concentration of particles containing carbon nanotubes at a production facility. This method allows differentiation of these particles from a background containing a variety of particles. The method works well, but is still in its infancy, and further development of the method towards performing this kind of differentiation in a less time costly way is needed.

To widen the focus and make a difference where it is really needed, it should be investigated whether combination of indoor measurements, as those conducted in homes in the Lund area, and the medical methods of investigating effects of exposure used in the exposure studies could be employed in countries where indoor pollution is a serious health problem. 67 % of the premature deaths due to indoor air pollution occur in Asia. In a developing country there, such as, say, India, where the indoor exposure levels are drastically higher than in Sweden, the described non-invasive methods could be used in field, in combination with exposure assessments. This could also provide knowledge on which intervention studies could be based.

To summarize: I have in this thesis described methods of field measurements, in which exposures and emissions have been investigated in detail, and aerosol characterizations have been made. I have shown that it is possible to reproduce realistic and well-characterized particles for human exposure studies, in which we can study how different particle properties affect the human body and health. This methodology has a large potential when it comes to map different particle types,

originating from both indoors and outdoors, to effects on the human being. It could also be used to establish dose-response relationships by using different concentrations of the same particle types. Dose-response relationships are essential when establishing threshold limits and performing risk analysis. New studies, with other types of common particles, have already begun, and future focus will depend on medical results of these and of the studies already conducted.

Indeed it is not feasible to conduct these kinds of human exposure studies with every type of aerosol that exists. The overall aim with our exposure studies, and field measurements, is to increase the general knowledge concerning which particle properties cause health effects and by which mechanisms. In the future, such knowledge is needed to be able to take proactive measures when designing new materials and reducing exposure to particles that affect our health.

Summary of the articles

Article I

Realistic indoor nano-aerosols for a human exposure facility

Isaxon C., Dierschke K., Pagels J.H., Wierzbicka A., Gudmundsson A., Löndahl J., Hagerman I., Berglund M., Assarsson E., Andersson U.B., Jönsson B.A.G., Nøjgaard J.K., Eriksson A., Nielsen J., Bohgard M.

The aim of this study was to achieve realistic levels of well characterized candle smoke particles and particles from terpene-ozone reactions in an experimental chamber intended for human exposure studies and aerosol characterization. The aerosol generation and characterization system consisted of a controlled, air-tight, stainless steel 22 m³ chamber, to which the generation systems were connected. No air could enter or leave the chamber except through a conditioning system by which temperature, relative humidity and air exchange rate could be controlled. Candle smoke aerosol was generated from ten candles burning in a 1.33 m³ glass and stainless steel chamber with a rotating fan. The aerosol was transported through a copper pipe with a residence time of less than 1 second and diluted by clean air from the conditioning system before entering the chamber. Terpene vapor was generated by passing pure nitrogen through a glass bottle containing limonene oil. Ozone was generated by a spark discharge using pure O₂, and was added to the ventilation air flow downstream the inlet for terpene vapors and upstream the inlet to the chamber. Both aerosols were characterized with respect to number concentrations (SMPS) and mass concentrations (TEOM), size distribution (SMPS) and chemical composition (OC/EC and PIXE for candle smoke aerosol and GC-MS and HR-ToF-AMS for particles generated by terpene-ozone reactions). Particle number concentration in the size range 10–650 nm as measured by an SMPS system could be varied from <10 cm⁻³ to more than 900 000 cm⁻³ (for candle smoke) or to more than 30 000 cm⁻³ (for particles formed in a 160 ppb terpene/40 ppb ozone mixture). The candle smoke aerosol was bi-modal with a mode of small inorganic water soluble particles (approximately 15 nm) which dominated the aerosol particle number concentration and a mode of approximately 200 nm particles dominated mostly of elemental

carbon. The aerosol from ozone–terpene reactions was uni-modal with a peak diameter of approximately 100 nm and was dominated by organic particles. For both aerosols we achieved repeatable generations at pre-determined concentration levels, which were stable over time. The results show that realistic concentrations of aerosols from real-world environments could be reproduced in a well-controlled manner and that this set-up could be used both for aerosol characterization and for human exposures.

Article II

A Novel System for Source Characterization and Controlled Human Exposure to Nanoparticle Aggregates Generated During Gas–Metal Arc Welding

Isaxon C., Dierschke K., Pagels J., Löndahl J., Gudmundsson A., Hagerman I., Berglund M., Wierzbicka A., Assarsson E., Andersson U.B., Jönsson B.A.G., Messing M.E., Nielsen J., Bohgard M.

The aim of this study was to achieve a method to perform generation and detailed characterization of mild steel, active gas, arc welding fume aerosol to be used for human exposure studies of nano-sized and nano-structured aerosol particles. The setup consisted of a generation chamber, where welding can be performed, connected to an air-tight, stainless steel, 22 m³ exposure chamber. Instrumentation, consisting of a TEOM for mass concentrations, an SMPS for number concentration and particle size distribution, and a sampler for electron microscopy and PIXE analysis, was connected to the stainless steel chamber. The feasibility of the system for human exposure studies was evaluated by, in a randomized fashion, exposing 31 human volunteers, in groups of three, to a test aerosol containing 1mg/m³ welding fumes and to conditioned, filtered air.

The results show that an aerosol that accurately represents dilute welding fume exposures that occur in workplaces can be produced in a controlled manner, and that the experimental setup can be used for 6 hour, double-blind, exposures of human subjects. Particle mass concentration levels could be varied from <5 µg/ m³ to more than 1000 µg/ m³. Fumes from metal active gas welding showed a unimodal size distribution with a mean mobility diameter of 160 nm. Transmission electron microscopy showed aggregates with a clearly nano-sized structure and the elemental composition of the welding fume particles was 70 mass-% iron, 20 mass-% manganese and 10 mass-% other species.

Article III

Contribution of indoor-generated particles to residential exposure

Isaxon C., Wierzbicka A., Gudmundsson A., Nordin E., Lönnblad L., Dahl A., Wieslander G., Bohgard M.

The aim of this study was to investigate the differences between residential and outdoor number concentrations with focus on particles smaller than 300 nm, to estimate contribution of different indoor sources to integrated daily residential exposure. An additional aim was to check the correlation between soot and number concentration of particles <300nm in residences in general as well as during different activities.

For seven consecutive days, time resolved stationary particle measurements were conducted in 36 randomly selected homes in the area around Lund in southern Sweden. Number concentrations and mean particle diameters were monitored with DiSC and NanoTracer, larger particles by Lighthouse. Soot mass concentrations were measured by microAeth. Detailed activity log books filled in by the residents were used for explaining variations in particle concentration. CO₂ data was collected and used to estimate air exchange rate and temperature and relative humidity was logged. Outdoor number concentrations were measured by SMPS from a station in northern Lund.

Air exchange rates could be estimated in 15 of the homes, ranging from 0.3 to 2.9 h⁻¹.

After sorting the data into occupancy time (at least one person present in the home) and non-occupancy time, the average concentration of particles during occupancy time was 50 000 cm⁻¹ and during non-occupancy time 6 000 cm⁻¹. Levels of 10 000 cm⁻¹ and more only occurred during presence of residents. 13 different activities could be identified as contributing significantly to the indoor particle concentration, with candle burning being the most dominant one. The average total integrated daily exposure was 399000 ± 351000 particles/cm³ x h/d, of which 66 % was contribution from known activities, 20 % from unknown activities and 14 % from background particles during non-activity time.

The soot measurements (microAeth) correlated 56 % with the DiSC and Nanotracer measurements, with higher correlation during combustion related activities.

Article IV

Exposure and Emission Measurements During Production, Purification, and Functionalization of Arc-Discharge-Produced Multi-walled Carbon Nanotubes

Hedmer M., **Isaxon C.**, Nilsson P.T., Ludvigsson L., Messing M.E., Genberg J., Skaug V., Bohgard M., Tinnerberg H., Pagels J.H.

The objective of this study was to quantify the occupational exposures and emissions to carbon nanotubes (CNTs). Personal exposure measurements in the breathing zone of workers as well as emission measurements near the expected emission source were performed during production, purification and functionalization of arc discharge produced multi walled CNTs (MWCNTs).

Respirable fractions of dust concentrations, elemental carbon (EC) concentrations and number concentrations of CNT containing particles were measured in the workers breathing zones with filter-based methods during work. Additionally, emission measurements near the source were carried out during different work tasks. Respirable dust was gravimetrically determined; EC was analyzed with thermal-optical analysis and the number of CNT containing particles was analyzed with scanning electron microscopy.

For the personal exposure measurements, respirable dust ranged between $<73-93 \mu\text{g m}^{-3}$, EC ranged between $<0.08-7.4 \mu\text{g C m}^{-3}$, and number concentration of CNT containing particles ranged between $0.04-2.0 \text{ cm}^{-3}$. For the emission measurements respirable dust ranged between $<2800-6800 \mu\text{g m}^{-3}$, EC ranged between $0.05-550 \mu\text{g C m}^{-3}$, 50 and number concentration of CNT containing particles ranged between <0.20 and 11.51 cm^{-3} . The highest exposure to CNTs occurred during production of CNTs. The highest emitted number concentration of CNT containing particles occurred in the sieving, mechanical work-up, pouring, weighing and packaging of CNT powder during the production stage. To be able to quantify exposures and emissions of CNTs a selective and sensitive method is needed. Limitations with measuring EC and respirable dust are that these exposure metrics does not measure CNTs specifically. Only filter based methods with electron microscopy analysis are to date selective and sensitive enough. This study showed that counting of CNT containing particles is the method that fulfils those criteria and is therefore the method recommended for future quantification of CNT exposures.

Article V

Effects on Heart Rate Variability by Artificially Generated Indoor Nano-sized Particles in a Chamber Study

Hagerman I., **Isaxon C.**, Gudmundsson A., Wierzbicka A., Dierschke K, Berglund M., Pagels J.H., Nielsen J., Assarsson E, Andersson U.B., Xu Y., Jönsson B.A.G., Bohgard M.

The aim of this study was to design a feasible chamber study with laboratory generated common indoor air particles (candle smoke and particles generated by terpene-ozone reactions) and to evaluate the impact of these nano-sized particles on noninvasive markers of cardiovascular reactivity such as heart rate and its variability. The hypothesis (H0) was defined as no observed changes in the high frequency band (HF) of HRV during exposure and if changes proven, resulting in rejection of H0.

Thirteen healthy female test subjects were exposed at three occasions by a randomized protocol, once for candle smoke, once for particles generated by terpene-ozone reactions and once to filtered air. Three 10 minute ECG recordings were made at each occasion in the exposure chamber. The first was made as a baseline, before exposures started. The ECG recordings were preceded by a 10 minute steady state (total rest) period.

The high frequency (HF) band was the primary endpoint for HRV analysis, since this is respiratory dependent. Low frequency (LF) was also studied, as well as LF/HF ratio. Percentage changes from baseline were calculated for each individual. All results were adjusted for age.

Exposure to candle smoke increased HF by 23.3 % ($p=0.01$), while exposure to particles generated by terpene-ozone reactions tended to decrease (however not significantly) HF by 7.2 % ($p=0.41$). The LF/HF ratio tended to decrease during exposure to candle smoke and increase during exposure to particles generated by terpene-ozone reactions.

The design of the chamber study together with the HRV method was shown to be a useful combination to get information on physiological response of exposure to particles of different concentrations, sizes and characteristics, which may contribute to the knowledge of health effects of airborne particles.

Author's contribution to presented articles

Article I

For studies as advanced as the one presented in this article (and in Article II and V), a large crew is needed. Many of the different parts of this study are the results of cooperation between many persons across different fields of science.

I designed and developed the generation and exposure system for an existing chamber. The exposure chamber had been evaluated beforehand, as a part of my diploma work.

I was part of designing the study and of analyzing the results.

I was responsible for generating the aerosols and monitoring the chamber air during the exposures.

I wrote the article.

Article II

I designed and developed the generation (partly based on a literature study by me and partly on an extensive welding workplace field study in which I partook) and exposure system.

I was part of designing the study and of analyzing the results.

I was responsible for generating the welding aerosol and monitoring the chamber air during the exposures.

I wrote the article.

Article III

I helped planning the study.

I had the main responsibility for the measurements and contacts with the residents.

I did the data analysis.

I wrote the article.

Article IV

I was part of planning the study.

Together with the main author I designed the measurement strategy.

I participated in the field measurements, where my main responsibilities were the emission and background measurements.

I helped evaluate and interpret the data.

I did parts of the writing.

Article V

I participated the planning and the conducting of the study.

I was responsible for the particle generation and the exposure chamber air monitoring.

I partook in the collecting of HRV data.

I wrote parts of the article and contributed to discussions about the results.

Author's publications, not presented in this thesis

Articles

Nilsson, P., Isaxon, C., Eriksson, A., Messing, M., Ludvigsson, L., Rissler, J., Hedmer, M., Tinnerberg, H., Gudmundsson, A., Deppert, K., Bohgard, M. & Pagels, J. (2013). Nano-objects emitted during maintenance of common particle generators: direct chemical characterization with aerosol mass spectrometry and implications for risk assessments. *Journal of Nanoparticle Research* 15(11).

Morawska L., Afshari A., Bae G.N., Buonanno G., Chao C. Y. H., Hänninen O., Hofmann W., Isaxon C., Jayaratne E. R., Pasanen P., Salthammer T., Waring M, Wierzbicka A. (2013). Indoor aerosols: from personal exposure to risk assessment. *Indoor Air* 23(6): 467-487.

Pagels J., Wierzbicka, A., Nilsson, E., Isaxon, C., Dahl, A., Gudmundsson, A., Swietlicki, E. & Bohgard, M. (2009). Chemical composition and mass emission factors of candle smoke particles. *Journal of Aerosol Science* 40(3) 193-208.

Reports

Gudmundsson A., Dahl A., Isaxon C., Wierzbicka A., Bohgard M. (2011). Kvantifiering av luftkvalitet i byggnader - Slutrapport från SBUF-projekt Dnr 12042. ISRN LUNDD/TMAT-3039-SE.

Conference proceedings

Isaxon C., Wieslande, G., Nordin E., Dahl A., Bohgard M. (2012). Feeling homesick? Time resolved air quality measurements in residential dwellings correlated to indoor activities. In: *Healthy Buildings 2012*, Brisbane, Australia, 2012-07-08.

Isaxon C., Dierschke K., Pagels J., Gudmundsson A., Hagerman I., Berglund M., Wierzbicka A., Assarsson E., Andersson U.B., Jönsson B.A.G., Bohgard M., Nielsen, J. (2012). Set-up for Human Chamber Exposure Studies of Airborne Particles. In: *Workplace and Indoor Aerosols Conference*, Lund University, Lund, Sweden, 2012-04-19 - 2012-04-20.

Isaxon C., Ludvigsson L., Nilsson P., Hedmer M., Tinnerberg H., Messing M., Rissler J., Skaug V., Bohgard M., Pagels J. (2012). Detection and identification of airborne multiwalled carbon nanotubes in arc discharge production. In: *Nanosafe 2012*, Grenoble, France, 2012-11-13.

Hedmer M., Isaxon C., Nilsson P., Ludvigsson L., Messing M., Skaug V., Tinnerberg H., Pagels, J. (2012). Measurements of exposure and emission of arc discharge produced multi-walled carbon nanotubes in a small scale facility. In: *International Congress on Safety of Engineered Nanoparticles and Nanotechnology*, Helsingfors, Finland, 2012-10-28.

Ludvigsson L., Isaxon C., Nilsson P., Messing M., Tinnerberg H., Hedmer M., Pagels J. (2012). Emissions of Arc Discharge Produced Multi-walled Carbon Nanotubes in an Industrial Environment. In: *Workplace and Indoor Aerosols Conference*, Lund University, Lund; Sweden, 2012-04-19 - 2012-04-20. 37.

Hedmer M., Isaxon C., Nilsson P., Eriksson A., Messing M., Tinnerberg H., Pagels J. (2012). Occupational hygiene and stationary emission measurements of engineered nanoparticles during cleaning operations in a clean room laboratory. In: *7th International Conference on the Science of Exposure Assessment*, Edinburg, Scotland, 2012-07-02.

Ludvigsson, L., Isaxon, C., Nilsson, P., Hedmer, M., Tinnerberg, H., Messing, M., Rissler, J., Skaug, V., Bohgard, M. & Pagels, J. (2012). Emission measurements of multi-walled carbon nanotube release during production. In: *NOSA Aerosol Symposium 2012*, Helsingör, 2012-11-15.

Nilsson P., Eriksson A., Messing M., Isaxon C., Hedmer M., Tinnerberg H., Meuller B., Deppert K., Bohgard M., Pagels J. (2012). Laser Vaporizer Aerosol Mass Spectrometry for Analysis of Particle Emissions During Maintenance of Aerosol ENP Generators. In: *Workplace and Indoor Aerosols Conference*, Lund University, Lund, Sweden, 2012-04-19 - 2012-04-20. 43.

Nilsson P., Eriksson A., Messing M., Isaxon C., Hedmer M., Tinnerberg H., Meuller B., Svensson C., Deppert K., Bohgard M., Pagels J. (2012). Laser Vaporizer-AMS for exposure assessment and detection of airborne engineered metal nanoparticles. In: *European Aerosol Conference 2012*, Granada.

Isaxon C., Dahl A., Nordin E., Wieslander G., Norbäck D., Gudmundsson A., Wierzbicka A., Bohgard M. (2011). Particles in Indoor Air – results from residential dwellings. In: *European Aerosol Conference 2011*, Manchester, UK, 2011-09-05.

Isaxon C., Hagerman I., Andersson U.B., Assarsson E., Berglund M., Broberg Palmgren K., Dahl A., Dierschke K., Gudmundsson A., Karlsson J.E., Kåredal M., Jönsson, B.A.G., Jönsson L.S., Pagels J., Swietlicki E., Tinnerberg H., Wierzbicka A., Nielsen J., Bohgard, M. (2011). Workplace Measurements and Studies of Physiological Responses of Welding Fume Exposure. In: *55th Nordic Work Environment Meeting* (Nordiska Arbetsmiljömötet), Lund, Sweden, 2011-10-17 - 2011-10-19.

Isaxon C., Dahl A., Nordin E., Wieslander G., Norbäck D., Gudmundsson A., Wierzbicka A., Bohgard, M. (2011). Particles in Indoor Air – measurements in residential dwellings. In: *Indoor Air 2011*, Austin, Texas, USA, 2011-06-05 - 2011-06-10.

Löndahl J., Isaxon C., Pagels J., Dierschke K., Wierzbicka A., Assarsson E., Gudmundsson A., Nielsen J., Bohgard, M. (2011). Measurements of Deposition of Inhaled Welding Fume Particles in the Human Lung. In: *55th Nordic Work Environment Meeting* (Nordiska Arbetsmiljömötet), Lund, Sweden, 2011-10-17 - 2011-10-19.

Bohgard M., Nielsen J., Hagerman I., Dierschke K., Isaxon C., Andersson U.B., Assarsson E., Berglund M., Gudmundsson A., Jönsson B.A.G., Pagels J., Wierzbicka, A. (2011). Physiological effects on humans when exposed to nanometer sized airborne particles in well controlled chamber studies. In: *Indoor Air 2011*, Austin, Texas, USA, 2011-06-05 - 2011-06-10.

Nilsson P., Eriksson A., Messing M., Isaxon C., Hedmer M., Tinnerberg H., Meuller B., Svensson C., Deppert K., Bohgard M., Pagels, J. (2011). Soot Particle-AMS for time and composition resolved detection of engineered metal particles. In: *NOSA*, Tampere, Finland.

Isaxon C., Wieslander G., Nordin E., Dahl A., Gudmundsson A., Bohgard, M. (2010). Methodology for Assessing Associations Between Exposure to Indoor Generated Airborne Particles and Health Effects in Residential Habitants. In: *International Aerosol Conference*, Helsinki, Finland, 2010-08-29 - 2010-09-03.

Dahl A., Isaxon C., Nordin E., Gudmundsson A., Wieslander G., Bohgard M. (2010). Use of Miniaturized Aerosol Instruments on Indoor Air. In: *International Aerosol Conference*, Helsinki, Finland, 2010-09-29 - 2010-09-30.

Hagerman I., Berglund M., Nielsen J., Andersson U.B., Assarsson E., Dierschke K., Gudmundsson A., Isaxon C., Pagels J., Wierzbicka A., Bohgard M. (2010). Effects on

heart rate variability of exposure to nano-sized airborne particles. In: *International Aerosol Conference*, Helsinki, Finland, 2010-09-29 .2010-10-03.

Isaxon C., Wierzbicka A., Eriksson A., Gudmundsson A., Nielsen J., Dierschke K., Assarsson E., Andersson U.B., Nøjgaard J.K., Bohgard, M. (2009). Generation of Nano Size Particles from Limonene/Ozone Reactions for Controlled Human Exposures in a Chamber. In: *European Aerosol Conference 2009*, Karlsruhe, Germany, 2009-09-06 - 2009-09-11.

Isaxon C., Pagels J., Gudmundsson A., Asbach C., John A.C., Kuhlbusch T.A.J., Karlsson J.E., Kammer R., Tinnerberg H., Nielsen J., Bohgard, M. (2008). Characteristics of Welding Fume Aerosol Investigated in Three Swedish Workshops. In: *10th International Symposium on Inhaled Particles*, Sheffield, England, Sep 23-25, 2008.

Isaxon C., Pagels J., Gudmundsson A., Löndahl J., Asbach C., John A., Kuhlbusch T.A.J., Karlsson J.E., Tinnerberg H., Kammer R., Nielsen J., Bohgard, M. (2008). Welding Fume Generation for Controlled Human Exposures Studies in Chamber - Comparison with Detailed Work Place Measurements. In: *European Aerosol Conference 2008*, Thessaloniki, Greece, 2008-08-24 - 2008-08-28.

Bohgard M., Nielsen J., Andersson U.B., Assarsson E., Berglund M., Broberg K., Dahl A., Dierschke K., Gudmundsson A., Hagerman I., Isaxon C., Kristiansson M., Jönsson B.A., Löndahl J., Pagels J., Swietlicki E., Tinnerberg H., Szpila, A. (2008). Methodology for Examination of Respiratory and Cardiovascular Effects of Airborne Nanoparticles Abundant in Indoor Environments. In: *Indoor Air 2008*, Copenhagen, Denmark, 2008-08-17 - 2008-08-22.

Bohgard M., Nielsen J., Andersson U.B., Assarsson E., Berglund M., Broberg K., Dahl A., Dierschke K., Gudmundsson A., Hagerman I., Isaxon C., Karlsson J.E., Kristiansson M., Jönsson B.A., Jönsson L.S., Löndahl J., Pagels J., Swietlicki E., Tinnerberg H., Wierzbicka, A. (2008). Method for exposure chamber studies to examine effects on humans of airborne nanoparticles from welding and burning candles. In: *European Aerosol Conference 2008*, Thessaloniki, Greece, 2008-08-24 - 2008-08-29.

Asbach C., John A.C., Pagels J., Isaxon C., Gudmundsson A., Karlsson J.E., Kammer R., Tinnerberg H., Nielsen J., Kuhlbusch T.A.J., Bohgard, M. (2008). Particle Size Distribution and Lung Deposited Surface Area Concentration in Welding Fumes Measured in Real Workplaces with High Time Resolution. In: *European Aerosol Conference 2008*, Thessaloniki, Greece, 2008-08-24 - 2008-08-28.

Löndahl J., Swietlicki E., Pagels J., Isaxon C., Gudmundsson A., Wierzbicka A., Nilsson E., Assarsson E., Dierschke K., Nielsen J., Bohgard, M. (2008). Improvement of a Method to Measure Respiratory Tract Deposition of Ambient Aerosol on

Humans - Application on Agglomerated Candle Smoke Particles. In: *European Aerosol Conference 2008*, Thessaloniki, Greece, 2008-08-24 - 2008-08-28.

Pagels J., Wierzbicka A., Nilsson E., Isaxon C., Dahl A., Löndahl J., Gudmundsson A., Swietlicki E., Bohgard, M. (2008). Indoor Sources of Fine and Ultrafine Particles - Detailed Particle Characterisation in an Indoor Chamber Setting. In: *Indoor Air 2008*, Copenhagen, Denmark, 2008-08-17 - 2008-08-22.

Asbach C., John A.C., Pagels J., Isaxon C., Gudmundsson A., Karlsson J.E., Ronny K., Tinnerberg H., Nielsen J., Thomas A.J.K., Bohgard M. (2008). Lung deposited surface area concentration and particle size distribution in welding fumes measured in real workplaces with high time resolution. In: *AAAR 27th Annual Conference*, Rosen Shingle Creek, Orlando, Florida, US, 2008-10-20 -2008-10-24.

Other

Isaxon C., Johansson E., Lidgard C., Nordin E., Rissler, J. (2010). Gränsdragningen för Universitetslärare i Relationen gentemot Studenterna – en analys av det egna förhållningssättet till yrkesmässighet och det privata. Lärande i LTH, 2010-12-01.

Isaxon C., Johansson E., Lidgard C., Nordin E., Rissler, J. (2010). Gränsdragningen för Universitetslärare i Relationen gentemot Studenterna – en analys av det egna förhållningssättet till yrkesmässighet och det privata. In: LTHs 6e Pedagogiska Inspirationskonferens, 2010-12-15.

References

- Abt E., Suh H.H., Allen G., Koutrakis P. (2000). Characterization of indoor particle sources: A study conducted in the metropolitan Boston area. *Environmental Health Perspectives*. 108: 35-44.
- AFS 211:18. Arbetsmiljöverkets föreskrift (Swedish Work Environment Authority).
- Afshari A., Matson U., and Ekberg L. E. (2005). Characterization of indoor sources of fine and ultrafine particles: a study conducted in a full-scale chamber. *Indoor Air* 15, 141-150.
- Anderson, Benedict, 1991. *Den föreställda gemenskapen. Reflexioner kring nationalismens ursprung och spridning*. Göteborg: Bokförlaget Daidalos.
- Antonini J.M., Health Effects of Welding (2003). *Critical Reviews in Toxicology*, 33(1): 61-103
- Antonini J.M., O'Callagan J.P., Miller D.B. (2006) Development of an animal model to study the potential neurotoxic effects associated with welding fume inhalation. *NeuroToxicology* 27: 745-751.
- Asbach, C., Kaminski, H., Von Barany, D. Kuhlbusch, T.A.J., Monz, C., Dziurowitz, N., Pelzer, J., Vossen, K., Berlin, K., Dietrich, S., Gotz, U., Kiesling, H.J., Schierl, R., Dahmann, D. (2012). Comparability of Portable Nanoparticle Exposure Monitors. *Annals of Occupational Hygiene*, 56: 606-621.
- Atkinson R., Arey J. (2003) Gas-phase tropospheric chemistry of biogenic volatile organic compounds: a review. *Atmospheric Environment* 37: 197-S219.
- Ball, William L., 1995. "The theoretical Analysis of Policy Arguments". <http://www.trenton.edul-ball/personal/polarg.html>. 18 augusti 1996. (Paper presented at Midwestern Political Science Association, 1992.).
- Bello D, Hart AJ, Ahn K., Hallock M., Yamamoto N., Garcia E.J., Ellenbecker M.J. Wardle B.L. (2008) Particle exposure levels during CVD growth and subsequent handling of vertically aligned carbon nanotube films. *Carbon*; 46: 974-7.
- Bello D, Wardle BL, Yamamoto N., deVilloria R.G., Garcia E.J., Hart A.J., Ahn K., Ellenbecker M.J., Hallock M. (2009) Exposure to nanoscale particles and fibers during machining of hybrid advanced composites containing carbon nanotubes. *Journal of Nanoparticle Research*; 11: 231-49.

- Bhangar S., Mullen N.A., Hering S.V., Kreisberg N.M., Nazaroff W.W. (2011). Ultrafine particle concentrations and exposures in seven residences in northern California. *Indoor Air* 21: 132-144
- Bekö G., Weschler C.J., Wierzbicka A., Karottki D.G., Toftum J., Loft S., Clausen G. (2013). Ultrafine particles: Exposure and source apportionment in 56 Danish homes. *Environmental Science and Technology* 47(18): 10240-10248.
- Bohgard M., Albin M. (2008). *Kemiska Hälsorisker*. In *Arbete och teknik på människans villkor*. Editors: Bohgard M., Karlsson S., Lovén E., Mikaelsson L-Å., Mårtensson L., Osvalder A-L., Rose L., Ulfvengren P. ISBN: 978-91-7365-037-3.
- Brasche S. and Bischof W. (2005). Daily time spent indoors in German homes – baseline data for the assessment of indoor exposure of German occupants. *International Journal of Hygiene and Environmental Health* 208: 247-253.
- Britigan N., Alshawa A., Nizkorodov S.A. (2006). Quantification of ozone levels in indoor environments generated by ionization and ozonolysis air purifiers. *Journal of the Air and Waste Management Association* 56(5): 601-610.
- Brook RD, Rajagopalan S, Pope CA, III, Brook JR, Bhatnagar A, Diez-Roux AV, Holguin F, Hong Y, Luepker RV, Mittleman MA, Peters A, Siscovick D, Smith SC, JR, Whitsel L, Kaufman JD,. (2010) Particulate Matter Air Pollution and Cardiovascular Disease: An Update to the Scientific Statement from the American Heart Association. *Circulation* 121: 2331-2378.
- Brook R.D., Urch B., Dvonch J.T., Bard R.L., Speck M., Keeler G., Morishita M., Marsik F.J., Kamal A.S., Kaciroti N., Harkema J., Corey P., Silverman F., Gold D.R., Wellenius G., Mittleman M.A., Rajagopalan S., Brook J.R. (2009). Insights Into the Mechanisms and Mediators of the Effects of Air Pollution Exposure on Blood Pressure and Vascular Function in Healthy Humans. *Hypertension* 54: 659-667.
- Brouwer D., van Duuren-Stuurman B., Berges M., Jankowska E., Bard D., Mark D. (2009). From workplace air measurement results toward estimates of exposure? Development of a strategy to assess exposure to manufactured nano-objects. *Journal of Nanoparticle Research* 11: 1867-1881.
- Brouwer D, Berges M, Virji MA et al. (2012) Harmonization of measurement strategies for exposure to manufactured nanoobjects; report of a workshop. *Annals of Occupational Hygiene* 56: 1–9.
- Brown D.M., Stone V., Findlay P., MacNee W. & Donaldson K. (2000) Increased inflammation and intracellular calcium caused by ultrafine carbon black is independent of transition metals or other soluble components. *Occupational and Environmental Medicine* 57:685-691.
- BSI. (2007) *Nanotechnologies - part 2: guide to safe handling and disposal of manufactured nanomaterials*, London: British Standards. PD 6699-2: 2007.
- Carslaw N., Langer S., Wolkoff P. (2009). New directions: where is the link between reactive indoor air chemistry and health effects? *Atmospheric Environment* 43: 3808-3809.

- Chen X., Hopke P.K. (2010). A chamber study of secondary organic aerosol formation by limonene ozonolysis. *Indoor Air* 20: 320–328.
- Cheng Y-H, Lin M-H. (2013). Real-Time Performance of the microAeth® AE51 and the Effects of Aerosol Loading on Its Measurement Results at a Traffic Site. *Aerosol and Air Quality Research*, 13: 1853–1863.
- Cockayne, Emily (2007). *Hubbub: Filth Noise & Stench in England*. Yale University Press. p. 61. ISBN 978-0-300-13756-9.
- Dahm MM, Evans DE, Schubauer-Berigan MK et al. (2012). Occupational exposure assessment in carbon nanotube and nanofiber primary and secondary manufacturers. *Annals of Occupational Hygiene* 56: 542–56.
- Dennekamp M., Howarth S., Dick C. A. J., Cherrie J. W., Donaldson K., Seaton A. (2001). Ultrafine particles and nitrogen oxides generated by gas and electric cooking. *Occupational and Environmental Medicine* 58: 511–516
- Derudi M., Gelosa S., Sliepecevic A., Cattaneo A., Rota R., Cavallo D, Nano G. (2012). Emissions of air pollutants from scented candles burning in a test chamber. *Atmospheric Environment* 55: 257-262.
- Derudi M., Gelosa S., Sliepecevic A., Cattaneo A., Cavallo D, Rota R., Nano G. (2013). Emission of air pollutants from burning candles with different composition in indoor environments. *Environmental Science and Pollution Research*. DOI 10.1007/s11356-013-2394-2.
- Destailats H., Lunden M.M., Singer B.C., Coleman B.K., Hodgson A.T., Weschler C.J., Nazaroff W.W. (2006). Indoor secondary pollutants from household product emissions in the presence of ozone: a bench-scale chamber study. *Environmental Science and Technology* 40: 4421-4428.
- Dewalle P., Vendel J., Weulersse J-M., Hevré P., Decobert G. (2010). Characterization of aerosols generated by nanosecond laser ablation of an acrylic paint. *Aerosol Science and Technology* 44(10): 902-915.
- Dockery, D. W. (2009). Health Effects of Particulate Air Pollution. *Annals of Epidemiology* 19(4): 257-263.
- Donaldson K., Murphy F., Schinwald A., Duffin R., Poland C.A., (2011). Identifying the pulmonary hazard of high aspect ratio nanoparticles to enable their safety-by-design. *Nanomedicine* 6(1):143-156.
- Fiedler N., Laumbach R., Kelly-McNeil K., Liroy P., Fan Z-H., Zhang J., Ottenweller J., Ohman-Strickland P., Kipen H. (2005). Health Effects of a Mixture of Indoor Air Volatile Organics, Their Ozone Oxidation Products and Stress. *Environmental Health Perspectives* 113(11): 1542-1548.
- Forsberg E. (2013). *Säker utveckling! Nationell handlingsplan för säker användning och hantering av nanomaterial*. SOU 2013:70.
- Gamaly E.G., Ebbesen T.W. (1995). Mechanism of carbon nanotube formation in the arc discharge. *Physical Review B* 52(3): 2083-2089.

- Glytsos T., Ondráček J, Dzumbová L., Kopanakis I., Lazaridis M. (2010). Characterization of particulate matter during controlled indoor environments. *Atmospheric Environment* 44: 1539-1549.
- Gong H., Linn W.S., Sioutas C., Terrell S.L., Clark K.W., Anderson K.R., Terrell L.L. (2003). Controlled Exposures of Healthy and Asthmatic Volunteers to Concentrated Ambient Fine Particles in Los Angeles. *Inhalation Toxicology* 15(4): 305-325.
- Gong H., Linn W.S., Clark K.W., Anderson K.R., Geller M.D., Sioutas C. (2006). Respiratory Responses to Exposures with Fine Particulates and Nitrogen Dioxide in the Elderly With and Without COPD. *Inhalation Toxicology* 17(3): 123-132.
- Grecco A.C.P., Paula R.F.O., Mizutani E., Sartorelli J.C., Milani A.M., Longhini A.L.F., Oliviera E.C., Pradella F., Silva V.D.R., Moraes A.S., Peterlevitz A.C., Farias A.S., Ceragioli H.J., Santos L.M.B., Baranauskas V. (2011). Up-regulation of T lymphocyte and antibody production by inflammatory cytokines released by macrophage exposure to multi-walled carbon nanotubes. *Nanotechnology* 22: 265103.
- Guo T., Nikolaev P., Thess A., Colbert D.T., Smalley R.E. (1995). Catalytic growth of single-walled nanotubes by laser vaporization. *Chemical Physics Letters* 243: 49-54.
- Hagerman I., Berglund M., Lorin M., Nowak J., Sylvén C. (1996). Chaos-related deterministic regulation of heart rate variability in time-and frequency domains: effects of autonomic blockade and exercise. *Cardiovascular Research* 31(3): 410-418.
- Han J.H., Lee E.J., Lee J.H., So K.P., Lee Y.H., Bae G.N., Lee S-B., Ji J.H., Cho M.H. Yu I.J. (2008) Monitoring multiwalled carbon nanotube exposure in carbon nanotube research facility. *Inhalation Toxicology* 20: 741-9.
- He C., Morawska L., Hitchins J., Gilbert D. (2004). Contribution from indoor sources to particle number and mass concentrations in residential houses. *Atmospheric Environment*, 38(21): 3405-3415.
- Hedlund, B. (2011). General Manager of the European Welding Association (EWA), private communication.
- Hedmer M., Kåredal M., Gustavsson P., Rissler J. (2013) The Nordic Expert Group for criteria documentation of health risks from chemicals. 148. Carbon nanotubes. *Arbete och Hälsa*; 47(5): 1-238. ISBN 978-91-85971-46-6, University of Gothenburg, Sweden.
- Hoek G., Kos G., Harrison R., de Hartog J, Meliefste K., ten Brink H., Katsouyanni K., Karakatsani A., Lianou M., Kotronarou A., Kavouras I., Pekkanen J., Vallius M., Kulmala M., Puustinen A., Thomas S., Meddings C., Ayres J., van Wijnen J., Hameri K. (2007). Indoor-outdoor relationships of particle number and mass in four European cities. *Atmospheric Environment* 42: 156-169.
- Huang YC, Ghio AJ, Stonehuerner J, McGee J, Carter JD, Grambow SC, Devlin R.B. (2003). The role of soluble components in ambient fine particles-induced changes in human lungs and blood. *Inhalation Toxicology* 15:327-342.

- Huston J.M., Tracey K.J. (2011). The pulse of inflammation: heart rate variability, the cholinergic anti-inflammatory pathway and implications for therapy. *Journal of Internal Medicine* 269: 45-53.
- Hussein T., Glytsos T., Ondráček J., Dohányosová P., Zdimál V., Hämeri K., Lazaridis M., Smolik J., Kulmala M. (2006) Particle size characterization and emission rates during indoor activities in a house. *Atmospheric Environment* 40: 4285-4307.
- Hussein T., Korhonen H., Herrmann E., Hämeri K., Lethinen K., Kulmala M. (2005). Emission rates due to indoor activities: Indoor aerosol model development, evaluation, and applications. *Aerosol Science and Technology* 39: 1111-1127.
- Hänninen, O., Knol, A. (Ed.), Jantunen, M., Kollanus, V., Leino, O., Happonen, E., Lim, T-A., Conrad, A., Rappolder, M., Carrer, P., Fanetti, A-C., Kim, R., Prüss-Üstün, A., Buekers, J., Torfs, R., Iavarone, I., Comba, P., Classen, T., Hornberg, C. and Mekel, O. (2011) European perspectives on Environmental Burden of Disease: Estimates for nine stressors in six countries. *THL Reports 1/2011*, Helsinki, Finland.
- IFA. (2009). Criteria for assessment of the effectiveness of protective measures. Available at: <http://www.dguv.de/ifa/Fachinfos/Nanopartikel-am-Arbeitsplatz/Beurteilung-von-Schutzma%C3%9Fnahmen/index-2.jsp>. Assessed 16 January 2014.
- Iijima S. (1991) Helical microtubules of graphitic carbon. *Nature*; 354: 56–8.
- Isaxon C., Pagels J., Gudmundsson A., Asbach C., John A. C., Kuhlbusch T. A. J., Karlsson J. E., Kammer R., Tinnerberg H., Nielsen J., Bohgard M. (2008). Characteristics of Welding Fume Aerosol Investigated in Three Swedish Workshops. *IPX*.
- Jenkins, N. T. (2003). *Chemistry of Airborne Particles from Metallurgical Processing*. Doctoral thesis, Massachusetts Institute of Technology, Cambridge, MA.
- Klenö-Nöjgaard J., Christensen K.B., Wolkoff P. (2005). The effect on human eye blink frequency of exposure to limonene oxidation products and methacrolein. *Toxicology Letters* 156(2): 241-251.
- Klenö J., Wolkoff P. (2004) Changes in eye blink frequency as a measure of trigeminal stimulation by exposure to limonene oxidation products, isoprene oxidation products and nitrate radicals. *International Archives of Occupational and Environmental Health* 77: 235-243.
- Koutrakis P., Brauer M., Briggs S.L.K., Leaderer B.P. (1991). Indoor exposures to fine aerosols and acid gases. *Environmental Health Perspectives*, 95: 23–28.
- Kreyling, W.G., Semmler, M., Erbe, F., Mayer, P., Takenaka, S., Schulz, H., Oberdorster, G., Ziesenis, A. (2002) Translocation of ultrafine insoluble iridium particles from lung epithelium to extrapulmonary organs is size dependent but very low, *Journal of Toxicology and Environmental Health Part A* 65:1513-1530.
- Krook, K. (2006). *Kemisk yrkes- och miljöhygien*. Arbetslivsinstitutet ISBN: 9789175229881.

- Kuhlbusch T.A.J., Asbach C., Fissan H., Göhler D., Stintz M. (2011). Nanoparticle exposure at nanotechnology workplaces: A review. *Particle and Fibre Toxicology* 8:22
- Kumar M., Ando Y. (2010). Chemical Vapor Deposition of Carbon Nanotubes: A Review on Growth Mechanism and Mass Production. *Journal of Nanoscience and Nanotechnology* 10(6): 3739-3758.
- Lamorena R. B., Jung S-G., Bae G-N., Lee W. (2007) The formation of ultra-fine particles during ozone-initiated oxidations with terpenes emitted from natural paint. *Journal of Hazardous Materials* 141: 245-251.
- Langer S., Moldanova J., Arrhenius K., Ljungström E., Ekberg L. (2008). Ultrafine particles produced by ozone/limonene reactions in indoor air under low/closed ventilation conditions. *Atmospheric Environment* 42: 4149-4159.
- Lee J.H., Lee S.B., Bae G.N., Jeon K.S., Yoon J.U., Ji J.H., Sung J.H., Lee B.G., Lee J.H., Yang J.S., Kim H.Y., Kang C.S., Yu I.L. (2010) Exposure assessment of carbon nanotube manufacturing workplaces. *Inhalation Toxicology* 22: 369–81.
- Lee S.C., Wang B. (2006). Characteristics of emissions of air pollutants from mosquito coils and candles burning in a large environmental chamber. *Atmospheric Environment* 40: 2128-2138.
- Leech J., Nelson W., Burnett R., Aaron S., Raizenne M (2002). It's about time: A comparison of Canadian and American time-activity patterns. *Journal of Exposure Analysis and Environmental Epidemiology* 12: 427-432.
- Leikauf G.D. (2002). Hazardous air pollutants and asthma. *Environmental Health Perspectives* 110(4): 505-526.
- Levy J., Diez D., Dou Y., Barr C., Dominici F. (2012) Systematic Reviews and Meta- and Pooled Analyses A Meta-Analysis and Multisite Time-Series Analysis of the Differential Toxicity of Major Fine Particulate Matter Constituents. *American Journal of Epidemiology* 175(11): 1091-1099.
- Li, N., Sioutas, C., Cho, A., Schmitz, D., Misra, C., Sempf, J., Wang, M.Y., Oberley, T., Froines, J., Nel, A. (2003) Ultrafine particulate pollutants induce oxidative stress and mitochondrial damage, *Environmental Health Perspectives* 111:455-460.
- Liu D.L., Nazaroff W.W. (2003). Particle penetration through building cracks. *Aerosol Science and Technology* 37(7): 565-573.
- Liu Y., Chen R., Shen X., Mao X. (2004). Wintertime indoor air levels of PM₁₀, PM_{2.5} and PM₁ at public places and their contributions to TSP. *Environment International* 30: 189-197.
- Larosa L.B., Buckley T.J., Wallace L.A. (2002). Real-time indoor and outdoor measurements of black carbon in an occupied house: an examination of sources. *Journal of the Air and Waste Management Association* 52: 41-49.
- Long C.M., Suh H.H., Koutrakis P. (2000). Characterization of indoor particle sources using continuous mass and size monitors. *Journal of the Air & Waste Management Association* 50: 1236-1250.

- Malik M. (1996). Heart Rate Variability. Standards of Measurement, Physiological Interpretation and Clinical Use. Task Force of the European Society of Cardiology and the North American Society of Pacing and Electrophysiology. *Circulation* 93: 1043-1065.
- Matson U. (2004). Indoor and outdoor concentrations of ultrafine particles in some Scandinavian rural and urban areas. *Science of the Total Environment* 343: 169-176.
- Maynard AD, Baron PA, Foley M et al. (2004) Exposure to carbon nanotube material: aerosol release during the handling of unrefined single walled carbon nanotube. *Journal of Toxicology and Environmental Health A*; 67: 87–107.
- McCormack, M.C., Breyse, P.N., Matsui, E.C. , Hansel, N.N. , Williams, D. , Curtin-Brosnan, J. , Eggleston, P. , Diette, G.B (2009) In-home particle concentrations and childhood asthma morbidity. *Environmental Health Perspectives* 117(2): 294-298.
- Medina-Ramon M., Zock J.P., Kogevinas M., Sunyer J., Torralba Y., Borrell A., Burgos F., Anto J.M. (2006). Asthma, cronic bronchitis, and exposure to irritant agents in occupational domestic cleaning: a nested case-control study. *Occupational and Environmental Medicine* 62: 598-606.
- Methner M., Hodson L. , Dames A., Geraci C. (2009). Measuring particle size-dependent physicochemical structure in airborne single walled carbon nanotube agglomerates. *Journal of Occupational and Environmental Hygiene* 7:127-132.
- Methner M., Hodson L., Gercai C. (2010). Nanoparticle Emission Assessment Technique (NEAT) for the identification and measurement of potential inhalation exposure to engineered nanomaterials – Part A. *Journal of Occupational and Environmental Hygiene* 7: 127-132.
- Mills NL, Donaldson K, Hadoke PW, Boon NA, Macnee W, Cassee FR, Sandstrom T, Blomberg A, Newby DE. (2009). Adverse cardiovascular effects of air pollution. *Nature Clinical Practice Cardiovascular Medicine* 6:36-4.
- Moisala A., Nasibulin, A.g., Shandakov S.D., Jiang H., Kauppinen E.I. (2005). On-line detection of single-walled carbon nanotube formation during aerosol synthesis methods. *Carbon* 43(10): 2066-2074.
- Morawska L., Afshari A., Bae G.N., Buonanno G., Chao C. Y. H., Hänninen O., Hofmann W., Isaxon C., Jayaratne E. R., Pasanen P., Salthammer T., Waring M, Wierzbicka A. (2013). Indoor aerosols: from personal exposure to risk assessment. *Indoor Air* 23(6): 467-487.
- Morawska L, He C, Hitchins J, Gilbert D, Parappukkaran S. (2001). The relationship between indoor and outdoor airborne particles in the residential environment. *Atmospheric Environment* 35:3463-3473.
- Morawska L. and Salthammer T., 2003. *Indoor Environment. Airborne Particles and Settled Dust*. WILEY-VCH, Weinheim.

- Mullen N.A., Liu C., Zhang Y., Wang S., Nazaroff W.W. (2011). Ultrafine particle concentrations and exposures in four high-rise Beijing apartments. *Atmospheric Environment* 45: 7574-7582.
- Murray D.M., Burmaster D.E. (1995). Residential air exchange rates in the United States: empirical and estimated parametric distributions by season and climatic region. *Risk Analysis* 15: 459-465.
- Nakanishi J, editor. (2011) Risk assessment of manufactured nanomaterials: carbon nanotubes (CNT). NEDO project (P06041) Research and development of nanoparticle characterization methods. Final report issued on 17 August 2011.
- Nawrot T.S., Perez L., Künzli N., Munters E., Nemery B. (2011). Public health importance of triggers of myocardial infarction: a comparative risk assessment. *The Lancet* 377(9767): 732-740.
- Nazaroff W.W. (2004). Indoor particle dynamics. *Indoor Air* 14: 175-183.
- Norbäck D. (2009) An update on sick building syndrome. *Current opinion in allergy and clinical immunology* 9(1): 55-59.
- Oberdorster G., Sharp Z., Atudorei V., Elder A., Gelein R., Kreyling W. & Cox C. (2004) Translocation of inhaled ultrafine particles to the brain. *Inhalation Toxicology* 16:437-445.
- Oberdorster, G., Sharp, Z., Atudorei, V., Elder, A., Gelein, R., Lunts, A., Kreyling, W., Cox, C. (2011). Extrapulmonary translocation of ultrafine carbon particles following whole-body inhalation exposure of rats. *Journal of Toxicology and Environmental Health Part A* 65:1531-1543.
- Orecchio S (2011) Polycyclic aromatic hydrocarbons (PAHs) in indoor emission from decorative candles. *Atmos Environ* 45:1888–1895.
- Pagels, J., Wierzbicka, A., Nilsson, E., Isaxon, C., Dahl, A., Gudmundsson, A., Swietlicki, E. & Bohgard, M. (2009). Chemical composition and mass emission factors of candle smoke particles. *Journal of Aerosol Science*, 40(3) 193-208.
- Pauluhn J. (2010) Subchronic 13-week inhalation exposure of rats to multiwalled carbon nanotubes: toxic effects are determined by density of agglomerate structures, not fibrillar structures. *Toxicological Sciences* 113: 226–42.
- Pekkanen J., Peters A., Hoek G., Tiittanen P., Brunekreef B., de Hartog J., Heinrich J., Ibaldo-Mulli A., Kreyling W.G., Lanki T., Timonen K.L. & Vanninen E. (2002) Particulate air pollution and risk of ST-segment depression during repeated submaximal exercise tests among subjects with coronary heart disease – The exposure and risk assessment for fine and ultrafine particles in ambient air (ULTRA) study. *Circulation* 106:933-938.
- Petry T., Cazelle E., Lloyd P., Mascarenhas R., Stijntjese G. (2013). A standard method for measuring benzene and formaldehyde emissions from candles in emission test chambers for human health risk assessment purposes. *Environmental Science Processes & Impacts* 15: 1369.

- Porter D.W., Hubbs A.F., Chen B.T. McKinney W., Mercer R.R., Wolfarth M.G., Batelli L., Wu N., Sriam K., Leonard S., Andrew M., Willard P., Tsuruoka S., Endo M., Tsukada T., Munekane F., Frazer D.G., Castranova V. (2013). Acute pulmonary dose-responses to inhaled multi-walled carbon nanotubes. *Nanotoxicology* 7: 1179–94.
- Quimby, B. J., and Ulrich, G. D. (1999). Fume Formation Rates in Gas Metal Arc Welding. *Welding Journal* 78(4):142–149.
- Redding, C. J. (2002). Fume Model for Gas Metal Arc Welding. *Welding Journal* June, 95–103.
- Reiss R, Anderson EL, Cross CE, Hidy G., Hoel D., McClellan R., Moolgavkar S. (2007). Evidence of health impacts of sulfate-and nitrate-containing particles in ambient air. *Inhalation Toxicology* 19(5): 419–449.
- Richardson G., Eick S., Jones R. (2005) How is the indoor environment related to asthma? Literature review. *Journal of Advanced Nursing* 52(3): 328-339.
- Rohr A.C. (2013). The health significance of gas- and particle-phase terpene oxidation products: A review. *Environment International* 60: 145-162.
- Rohr A.C., Weschler C.J., Koutrakis P., Spengler J.D. (2003). Generation and Quantification of Ultrafine Particles through Terpene/Ozone Reaction in a Chamber Setting. *Aerosol Science and Technology* 37: 65-78.
- Salvi S, Blomberg A, Rudell B, Kelly F, Sandström T, Holgate ST, Frew A. (1999). Acute inflammatory responses in the airways and peripheral blood after short-term exposure to diesel exhaust in healthy human volunteers. *American Journal of Respiratory and Critical Care Medicine* 159(3): 702-709.
- Sanchez V.C., Pietruska J.R., Miselis N.R., Hurt R.H., Kane A.B. (2009). Biopersistence and potential adverse health impacts of fibrous nanomaterials: what have we learned from asbestos? *Nanomedicine and Nanobiotechnology* 1(5): 511-529.
- Sarwar G., Corsi R. (2007). The effects of ozone/limonene reactions on indoor secondary organic aerosols. *Atmospheric Environment* 41: 959-973.
- Sehlfstedt M., Behndig A.F., Boman C., Blomberg A., Sandström T., Pourazar J. (2010a). Airway inflammatory response to diesel exhaust generated at urban cycle running conditions. *Inhalation Toxicology* 24(14): 1144-1150.
- Sehlfstedt M., Dove R., Boman C., Pagels J., Swietlicki E., Löndahl J., Westerholm R., Bosson J., Barath S., Behndig A. F., Pourazar J., Sandström T., Mudway I. S., Blomberg A. (2010b). Antioxidant airway responses following experimental exposure to wood smoke in man. *Particle and Fibre Toxicology* 7:21.
- Sherriff A., Farrow A., Golding J., the ALSPAC Study Team, Henderson J. (2005). Frequent use of chemical household products is associated with persistent wheezing in pre-school age children. *Thorax* 60: 45-49.
- Shooto DN, Dikio ED (2011) Morphological characterization of soot from the combustion of candle wax. *Int J Electrochem Soc* 6:1269–1276.

- Singer B. C., Destaillets H., Hodgson A. T., Nazaroff W. W. (2006) Cleaning products and air fresheners: emissions and resulting concentrations of glycol ethers and terpenoids, *Indoor Air* 16: 179-191.
- Sivagangabalan G., Spears D., Masse S., Urch B., Brook R.D., Silverman F., Diane Gold R., Lukic K.Z., Speck M., Kusha M., Farid T., Poku K., Shi E., Floras J., Nanthakumar K. (2011). The effect of air pollution on spatial dispersion of myocardial repolarization in healthy human volunteers. *Journal of American College of Cardiology* 57(2): 198-206.
- Sorensen M., Loft S., Andersen H.V., Nielsen O.R., Skovgaard L.T., Knudsen L.E. (2005). Personal exposure to PM_{2.5}, black smoke and NO₂ in Copenhagen: relationship to bedroom and outdoor concentrations covering seasonal variation. *Journal of Exposure Analysis and Environmental Epidemiology*. 15: 413-422.
- Stabile L., Fuoco F.C., Buonanno G. (2012). Characteristics of particles and black carbon emitted by combustion of incenses, candles and anti-mosquito products. *Building and Environment* 56: 184-191.
- Stenfors N, Nordenhäll C, Salvi SS, Mudway I, Söderberg M, Blomberg A, Helleday R, Levin JO, Holgate ST, Kelly FJ, Frew AJ, Sandström T. (2004). Different airway inflammatory responses in asthmatic and healthy humans exposed to diesel. *European Respiratory Journal* 23(1):82-86.
- Tainto M., Tuomisto J.T., Pekkanen J., Karvosenoja N., Kupiainen K., Porvari P., Sofiev M., Karppinen A., Kangas :, Kukkonen J. (2010). Uncertainty in health risks due to anthropogenic primary fine particulate matter from different source types in Finland. *Atmospheric Environment* 44(17):2125-2132.
- Thatcher T., Lunden M., Revzan K., Sextro R., Brown N. (2003). A concentration rebound method for measuring particle penetration and deposition in the indoor environment. *Aerosol Science and Technology* 37: 847-864.
- Tkach A.V., Shurin G.V., Shurin M.R., Kisin E.R., Murray A.R., Young S-H., Star A., Fadeel B., Kagan V.E., Shvedova A.A. (2011). Direct Effects of Carbon Nanotubes on Dendritic Cells Induce Immune Suppression Upon Pulmonary Exposure. *ACS Nano* 5(7): 5755-5762.
- Trout D.B., Schulte P.A. (2010). Medical surveillance, exposure registries, and epidemiologic research for workers exposed to nanomaterials. *Toxicology* 269(2-3): 128-135.
- Turpin, B.J., Weisel, C.P., Morandi, M., Colome, S. and Stock, T. (2007) Relationships of Indoor, Outdoor, and Personal Air (RIOPA): Part II. Analyses of Concentrations of Particulate Matter species, Health Effects Institute, Report 130, Part II (Available at www.healtheffects.org).
- Yu IJ, Kim KJ, Chang HK, Song KS, Han KT, Han JH, et al. Pattern of deposition of stainless steel welding fume particles inhaled into the respiratory systems of Sprague–Dawley rats exposed to a novel welding fume generating system. *Toxicol Lett* 2000;116:103–11.

- Yu IJ, Song KS, Chang HK, Han JH, Kim KJ, Chung YH, et al. Lung fibrosis in Sprague–Dawley rats induced by exposure to manual metal arc-stainless steel welding fumes. *Toxicol Sci* 2001;63:99–106.
- Wainman T., Zhang J. F., Weschler C. J., and Liyo P. J. (2000). Ozone and limonene in indoor air: A source of submicron particle exposure. *Environmental Health Perspectives*, 108: 1139-1145.
- Wallace L. and Ott W. (2011). Personal exposure to ultrafine particles. *Journal of Exposure Science and Environmental Epidemiology* 21: 20-30.
- Wallace L., Williams R., Rea A., Croghan C. (2006). Continuous weeklong measurements of personal exposures and indoor concentrations of fine particles for 37 health-impaired North Carolina residents for up to four seasons. *Atmospheric Environment* 40(3): 399-414.
- Wan, M-P., Wu, C-L., Sze To, G-N., Chan, T-C. and Chao, C.Y.H. (2011) Ultrafine particles and PM_{2.5} generated from cooking in homes, *Atmospheric Environment*, 45(34): 6141-6148.
- Warheit D.B., Webb K.L., Reed S.F., Sayes C.M. (2007). Pulmonary toxicity study in rats with three forms of ultrafine-TiO₂ particles. *Toxicology* 230: 90-104.
- Vartiainen E., Kulmala M., Ruuskanen T.M., Taipale R., Rinne J., Vehkamäki H. (2006). Formation of indoor air aerosol particles as a result of D.limonene oxidation. *Atmospheric Environment* 40: 7882-7892.
- Weichenthal S. (2012). Selected physiological effects of ultrafine particles in acute cardiovascular morbidity. *Environmental Research* 115: 26-36.
- Weschler C.J. (2000). Ozone in indoor environments: concentration and chemistry. *Indoor Air* 10: 269-288.
- Weschler C.J. (2004). New directions: ozone-initiated reaction products indoors may be more harmful than ozone itself. *Atmospheric Environment* 38: 5715-5716.
- Weschler C. J. (2006) Ozone's Impact on Public Health: Contributions from Indoor Exposures to Ozone and Products of Ozone-Initiated Chemistry. *Environmental Health Perspectives* 114(10): 1489-1496.
- Weschler C.J. (2011). Chemistry in indoor environments: 20 years of research. *Indoor Air* 21: 205-218.
- Weschler C.J., Shields H.C. (1997). Potential reactions among indoor pollutants. *Atmospheric Environment* 31(21): 3487-3495.
- WHO (2002). *World Health Report – reducing risks, promoting healthy life*. Geneva: World Health Organization. ISBN 92 4 156207
- WHO. (1997) Determination of airborne fibre number concentrations: a recommended method, by phasecontrast optical microscopy (membrane filter method). Geneva: World Health Organization. ISBN 92 4154496 1.

- Wierzbicka A. (2008). What are the characteristics of airborne particles that we are exposed to? Focus on indoor environments and emissions from biomass fired district heating. Doctoral thesis. Lund University, Sweden.
- Wolkoff P, Clausen P.A., Larsen S.T., Hammer M., Damgård-Nielsen G. (2012). Airway effects of repeated exposures to ozone-initiated limonene oxidation products as model of indoor air mixtures. *Toxicology Letters* 209(2): 166-72.
- Yeganeh B., Kull C.M., Hull M.S., Marr L.C. (2008). Characterization of airborne particles during production of carbonaceous nanomaterials. *Environmental Science and Technology* 42: 4600-4606.
- Youssefi S., Waring M.S. (2012). Predicting secondary organic aerosol information from terpenoid ozonolysis with varying yields in indoor environments. *Indoor Air* 22(5): 415-426.
- Zai S., Zhen H., Jia-song W. (2006). Studies on size distribution, number and mass emission factors of candle particles characterized by modes of burning. *Journal of Aerosol Science* 37: 1484-1496.
- Zang J., Liou P.J. (1994). Ozone in residential air: Concentrations, I/O ratios, indoor chemistry, and exposures. *Indoor Air* 4:95-105.
- Zimmer A. T., Baron P. A., Biswas P. (2002). The influence of operating parameters on number-weighted aerosol size distribution generated from a gas metal arc welding process, *Journal of Aerosol Science* 33: 519-531.
- Zimmer, A. T., and Biswas, P. (2001). Characterization of the Aerosols Resulting from Arc Welding Processes. *Journal of Aerosol Science* 32:993–1008.

Article I



Contents lists available at SciVerse ScienceDirect

Journal of Aerosol Science

journal homepage: www.elsevier.com/locate/jaerosci

Realistic indoor nano-aerosols for a human exposure facility



C. Isaxon^{a,*}, K. Dierschke^b, J.H. Pagels^a, A. Wierzbicka^a, A. Gudmundsson^a,
J. Löndahl^a, I. Hagerman^c, M. Berglund^c, E. Assarsson^b, U.B. Andersson^b,
B.A.G. Jönsson^b, J.K. Nøjgaard^d, A. Eriksson^a, J. Nielsen^b, M. Bohgard^a

^a Department of Design Sciences, Ergonomics and Aerosol Technology, Lund University, Box 118, SE-221 00 Lund, Sweden

^b Department of Medicine, Occupational and Environmental Medicine, Lund University, SUS, SE-221 85 Lund, Sweden

^c Department of Medicine, Huddinge, Karolinska Institutet, M52, SE-141 86 Stockholm, Sweden

^d Department of Environmental Science, Aarhus University, DK-4000 Roskilde, Denmark

ARTICLE INFO

Article history:

Received 12 June 2012

Received in revised form

5 February 2013

Accepted 5 February 2013

Available online 19 February 2013

Keywords:

Indoor aerosol

Exposure

Generation

Characterization

Candle smoke

SOA

ABSTRACT

The aim of this study was to achieve realistic levels of two different types of aerosols commonly abundant in indoor environments in an experimental chamber intended for human exposure studies and aerosol characterization. The aerosols chosen were particles from candle lights (in particle number dominated by inorganic water soluble particles) and from ozone–terpene reactions (organic particles). The aerosol generation and characterization system consisted of a controlled air tight stainless steel 22 m³ chamber, to which the generation set-ups were connected. No air could enter or leave the chamber except through a conditioning system by which temperature, relative humidity and air exchange rate could be controlled. Candle smoke aerosol was generated from ten candles burning in a 1.33 m³ glass and stainless steel chamber. The aerosol was diluted by clean air from the conditioning system before entering the chamber. Terpene vapor was generated by passing pure nitrogen through a glass bottle containing limonene oil. Ozone was generated by a spark discharge using pure O₂, and was added to the ventilation air flow downstream the inlet for terpene vapors and upstream the inlet to the chamber. Both aerosols were characterized with respect to number and mass concentrations, size distribution and chemical composition. Particle number concentration in the size range 10–650 nm could be varied from < 10 cm⁻³ to more than 900,000 cm⁻³ (for candle smoke) or to more than 30,000 cm⁻³ (for particles formed in a 160 ppb terpene/40 ppb ozone mixture). Furthermore, the set-ups were evaluated by, for each source, repeating the generation at six three-hour long events. For both aerosols repeatable generations at pre-determined concentration levels, that were stable over time, could be achieved. The results show that realistic concentrations of aerosols from real-world environments could be reproduced in a well-controlled manner and that this set-up could be used both for aerosol characterization and for human exposures.

© 2013 Elsevier Ltd. All rights reserved.

1. Introduction

The scientific literature has given us a lot of epidemiological significant relations between particle exposure and mortality/morbidity. In indoor air, these relations have been well recognized for more than ten years (Schneider et al., 2003). Most of our general knowledge of particle health impact is derived from toxicological studies (in animals and cells)

* Corresponding author. Tel.: +46 462 223 935; fax: +46 462 224 431.

E-mail address: christina.isaxon@design.lth.se (C. Isaxon).

and from epidemiological studies based on measurements of outdoor particles and large populations. However, there is a fundamental lack when it comes to solid experimental studies on physiological effects on humans exposed to these particles. This lack is particularly evident when it comes to engineered nanoparticles (ENPs). These particles have high surface-to-mass ratio and are often chemically functionalized. ENPs, if they are airborne, are likely to affect occupational health and the health of consumers handling the products (Savolainen et al., 2010a, b), for example by penetration to the blood stream if deposited in the alveoli. Since the production of ENPs is increasing, and is very likely to do so even more in the future, the exposure to these particles will also increase.

We are already today surrounded by many different types of airborne particles in the nanometer size range, and by learning how to generate these in laboratory setting and use them for human exposure studies, we can gain knowledge which could be applied also to the risk assessment of airborne ENPs.

It is therefore of interest to use exposure studies to investigate how human health is affected by particle sources in the surrounding air, using realistic particle concentrations and common particle types. Well designed, reproducible human exposure studies cannot be performed without well designed and well controlled exposure facilities. Such a facility generally consists of two major parts: an exposure chamber and an aerosol generation system. In the chamber, parameters such as temperature, relative humidity, complete mixture of the air volume, wall deposition and air exchange rate need to be controlled. The subjects of exposure should be able to rest comfortably. A chamber with substantial space also provides the possibility to have the subjects perform lighter, or heavier, exercise. No matter how advanced, an exposure chamber is not useful without a well-functioning system by which relevant aerosols can be generated. There are several challenges involved in the creation of such a system. The first is deciding what a “realistic aerosol” is. If the aim is to study health effects of exposure to particles sources in the surrounding air, these sources need to be identified and characterized, both when it comes to concentration and chemical composition. Then, such a source needs to be generated in a laboratory setting, including thorough characterization to ensure its resemblance to the real life aerosol. It is desired to achieve concentrations high enough to ensure that if there is a physiological effect, its signal is seen. Target concentrations can be higher than normal indoor concentrations, since the exposure time is relatively short (3 h in this case) compared to everyday indoor exposure, but low enough to be realistic and ethically defensible. Once this is achieved, reproducibility must be ensured. Finally, the aerosol must be delivered into the exposure chamber with a minimum of residence time in the delivery system, to ensure that no undesired aerosol dynamic processes, such as coagulation, occur.

The objectives of this work were to develop generation systems for two different types of aerosols containing nanosized particles, commonly abundant in indoor air, which can be ethically justified for human exposure. Furthermore, the objective was to achieve realistic concentration levels, i.e. high enough for meaningful studies of physiological responses on humans, but not so high that it may cause unrealistic and unethical exposures.

2. Choice of aerosol sources and concentrations

Two commonly abundant indoor particle types were chosen for this study: candle smoke particles and particles from terpene–ozone reactions.

In several field studies in homes, candles have been identified as significant sources of ultra-fine particles (Hussein et al., 2006; Matson, 2005; Wierzbicka, 2008) and a major contributor to indoor elemental carbon (EC) and PM_{2.5} concentrations (Larosa et al., 2002; Sorensen et al., 2005). The candle flame can be approximated as a diffusion flame, with the wax serving as fuel and the wick serving as transport mode of the fuel by capillary forces. Air is the oxidant, transported by convection vertically along the flame. In fuel rich regions of the flame, large quantities of soot particles form. The yellow incandescent light making up a majority of the flame is the result of soot oxidation. During steady burn, in principle all soot formed in the flame can be oxidized, resulting in very low EC (soot) emissions. However high number concentrations of ultrafine, nucleation mode particles form even during steady burn. These have been shown to consist of soluble alkali phosphates and nitrates originating from flame retardant additives to the wick (Pagels et al., 2009). During horizontal air movements in the vicinity of the flame, e.g. due to an open window, a flickering flame will result, and soot will be able to escape without being oxidized. An additional potential health problem related to candle burning is the occurrence and release of metal additives from the wick and color pigments from the wax.

Pagels et al. (2009) conducted a set of experiments in which four candles made of paraffin/stearin were burned in a well-controlled chamber (the same chamber described below). During sooting burn, when the flames were unshielded and made to flicker due to air movements from a fan, the concentration of soot in the chamber air increased by more than one and a half orders of magnitude. The paraffin/stearin candle had significantly higher soot emissions than a more expensive candle made by pure stearin. Pagels et al. found that the average diameter of the nucleation mode candle smoke primary particle diameter was 25–30 nm (these make up the majority of the number concentration), and that the mean mobility diameter of the agglomerated larger soot particle mode were in the order of 270 nm, which is significantly larger than that for diesel exhaust (Maricq, 2007). However, the primary particle size and structure is similar for candle and diesel soot (Pagels et al., 2009).

Several sources of unsaturated volatile organic compounds (VOCs) can be found indoors, released from for example woods, carpets, paints, cleaning products, polishes, air fresheners and perfumes (Weschler, 2006). Terpenes, in particular *d*-limonene and α -pinene, are common constituents of commercial cleaning products and are among the volatile unsaturated organic compounds most frequently encountered in indoor environments (Fiedler et al., 2005). For example *d*-limonene is often added to cleaning products in the form of lemon oil to give the room a fresh scent when cleaning, but can also, along with other VOCs,

be emitted for example from paint (Lamorena et al., 2007). When ozone is present, *d*-limonene is rapidly oxidized and forms both relatively short lived products (of which many however exists long enough to be inhaled and transported into the respiratory tract) and stable, irritating end products including high vapor pressure compounds in the gas-phase such as formaldehyde (Atkinson & Arey, 2003; Wolkoff et al., 2012) and lower vapor pressure products that form secondary organic aerosol (SOA) either through nucleation of new ultrafine particles or through condensation on existing particles (Wainman et al., 2000; Weschler, 2006). In addition to stable oxidation products, terpene ozonolysis is a major source of indoor radicals, such as OH, Criegee Intermediates and other organic radicals (Atkinson & Arey, 2003), which are suspected to cause eye and airway irritation (Kleno & Wolkoff, 2004).

The reaction of ozone with various terpenes in indoor settings has been showed to contribute tens of micrograms per cubic meter to the indoor concentration of submicrometer particles (Destailats et al., 2006). The use of terpene containing cleaning products can result in peak particle mass concentrations in the magnitude of mg/m^3 in indoor air and levels up to tenths to hundreds of $\mu\text{g}/\text{m}^3$ can be maintained for several hours after a cleaning event (Singer et al., 2006).

The two chosen types of aerosols contain two different types of particles; the candle aerosol is dominated by water soluble inorganic salts (which will create electrolytic ions when dissolved) and soot, whereas the terpene–ozone particles contain organic particles. From our own studies and from literature we conclude that realistic concentrations suitable for exposure studies should for candle particles be in the range 5×10^5 to $1 \times 10^6 \text{ cm}^{-3}$, $200 \mu\text{g}/\text{m}^3$ and for particles generated by terpene–ozone reactions 10^4 – 10^5 cm^{-3} , 80 – $100 \mu\text{g}/\text{m}^3$.

3. Method

3.1. Description of the exposure facility and its operation

The exposure chamber is a 21.6 m^3 room where all interior surfaces are made out of stainless steel, except for a window of 0.8 m^2 (Figs. 1 and 2). No air can enter or leave the chamber except through its well-controlled ventilation system.

The exposure room is entered via an antechamber (3.1 m^3) through air tight doors, the seals of the inner door are expanded by pressurized air, both to the chamber and to the surrounding laboratory. The air supplied to the antechamber is exhaust air from the chamber itself, which minimizes contamination of the chamber air when entering or leaving. The exposure chamber is supplied with air through a separate custom-built conditioning system by which air flow, temperature and relative humidity are controlled and adjusted. After being filtered inside the conditioning system, the chamber air supply passes through an additional set of filters: an activated carbon filter and an ultra-low penetration air (ULPA) filter, before entering the exposure chamber at roof level. The generated aerosol and aerosol forming precursors are pre-mixed with the supply air and passed into the clean air stream just above the chamber inlet at roof level. With the conditioning system the exposure chamber can be set to air exchange rates up to 4.5 h^{-1} . The aerosol generation flow can add to the air flow from the conditioning system, resulting in an air exchange rate of up to 5.8 h^{-1} .

The chamber air exhaust is situated at 0.8 m height at the diagonally opposite corner of the air inlet. The exhaust flow is controlled using a variable exhaust fan. This fan is also utilized for achieving a desired slight over-pressure or under-pressure inside the chamber compared to the surroundings. This is done to make sure no particles from the surrounding air penetrate into the chamber (over-pressure) or that no exposure aerosol leaks out (under-pressure). The chamber can quickly be emptied of remaining aerosols after an experiment with the help of an express fan. Then air is supplied from the surrounding room, passed through a filter with pelleted active carbon and through a HEPA filter before entering the chamber at high flow rate. The express system provides an air exchange rate of $\sim 15 \text{ h}^{-1}$, and in 15–20 min the particle concentration is down to 1% of the initial concentration.



Fig. 1. The stainless steel exposure chamber at Lund University.

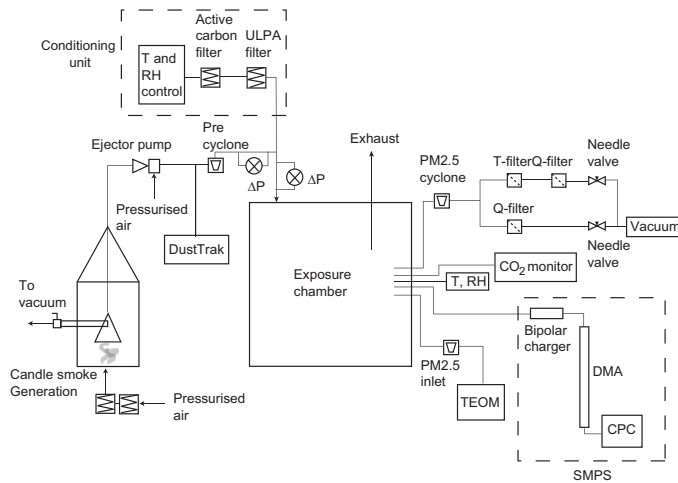

Fig. 2. Schematic view of the complete candle aerosol generation/exposure system.

At air exchange rates of around 4 h^{-1} , concentration gradients are less than 15% throughout the chamber volume. In the presence of test subjects, the degree of mixing improves further due to the thermal convection induced by the test subjects.

3.2. Methods of aerosol generation

For candle smoke generation blue tapered candles consisting of a mixture of stearine and paraffin (extensively characterized by Pagels et al., 2009) was used, manufactured by a market leading company in Sweden. Ten candles were lit 10 min prior to experiment start and placed under the extractor hood. A fan (Model AFT-25, Appliance, Helsingborg, Sweden, set at 140 V) was set to rotate from side to side, sweeping over the set of candles creating a temporary turbulence in the flames but leaving the candles in a steady burn the majority of the time, hence the candles were made to produce both small nucleation mode particles consisting of alkali salts (Pagels et al., 2009) and larger sized agglomerated soot particles. This resembles a real indoor setting, where candles burning on a table often flicker and emit soot when persons move about or when a door or window is opened, but will burn steadily otherwise.

The candle smoke aerosol was generated in a 1.33 m^3 glass and stainless steel chamber (bottom surface area 0.81 m^2). Clean (filtered by a high efficiency HEPA particle filter and an active carbon filter) pressurized air was introduced in the bottom of the generation chamber. This provided a steady, controlled flow of fresh air through the generation chamber. The generated aerosol was captured by an extractor hood with an inlet area of $0.39 \text{ m} \times 0.16 \text{ m}$, placed 0.3 m above the burning candles. The extractor hood was connected to an 8.25 m long copper tube, 3 cm in diameter, through which the aerosol was transported with the help of an air amplifier (Coval, model M10C, Raleigh, NC, USA) into the exposure chamber. When pressurized air is injected perpendicular to the aerosol flow in the amplifier a low pressure area is created, which entrains aerosol from the generation volume and produces high velocity outlet flows. 400 lpm of aerosol was entrained by the amplifier when operated with filtered pressurized air at 4 bar (400 kPa), resulting in an outlet flow of 500 lpm . Flow-rates could be varied by adjusting the operating pressure of the air amplifier. By using the extractor hood and air amplifier the residence time of the aerosol in the generation system could be kept at a minimum (approximately 2 s until dilution in the exposure chamber) and hence aerosol dynamic processes, mainly from coagulation, could be reduced. Coagulation easily occurs with high number concentrations and long residence time, and changes the number size distribution towards larger and fewer particles, neither of which is desired in these experiments.

A cyclone was placed downstream the air amplifier to avoid particles larger than $2\text{--}3 \mu\text{m}$, which could have been deposited in pipe bends and in the amplifier to reach the exposure chamber. Such mechanically generated particles are not desirable, as exposure of candle smoke occur mainly as fine and ultra-fine particles. The relative changes in concentration upstream the air amplifier was assessed using a photometer (TSI, DustTrak Model 8520, Shoreview, MN, USA). The concentration of aerosol transported out of the generation chamber could be varied by opening a valve in the extractor hood, which lets a desired amount of the aerosol be vented away. When the mass concentration was kept at $200 \mu\text{g}/\text{m}^3$ the number concentration was around $800,000 \text{ cm}^{-3}$, with the described generation method. A simple box model (Koutrakis et al., 1991) was used to verify that this mass concentration was realistic compared to indoor settings. Parameters used in the model was a 75 m^3 room, with complete mixture of the air, an air exchange rate of 0.5 h^{-1} , a wall deposition of 1.9 h^{-1}

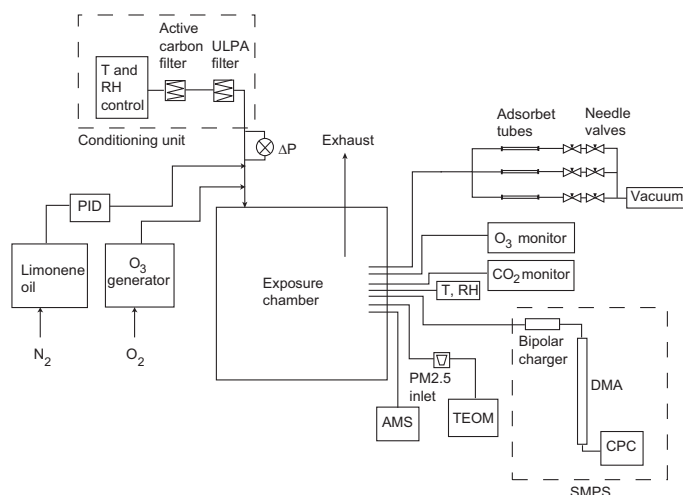

Fig. 3. Schematic view of the complete terpene–ozone generation/exposure system.

(mean value from studies made by He et al. (2005)) and emission factors from Pagels et al. (2009) of steady burn candles and sooting burn candles, respectively. The calculations confirmed that $200 \mu\text{g}/\text{m}^3$ corresponded to 2h steady burn of 12–18 candles or 2 h sooting burn of 1–4 candles. The described generation method aimed for an intermediate mode of burning, which, based on these calculations, would correspond to for example a couple of hour's dinner event with burning candles and people moving about.

Terpene vapor was generated just outside the exposure chamber (Fig. 3) by passing pure nitrogen (2 lpm) at room temperature ($20 \pm 2 \text{ }^\circ\text{C}$) through a glass bottle containing 6.7 ml of limonene in form of commercial essential oil (lemon oil, oleum citri, Interlam AB, Malmö, Sweden). The obtained limonene vapors were supplied to the chamber and the equilibrium level corresponded to 160 ppb (in the chamber) in the absence of ozone. The concentration of limonene and trace amounts of other VOCs emitted to the chamber were analyzed with adsorbent tubes and GC–MS as described below in absence and presence of ozone in the chamber. The VOC level was monitored with a photoionization detector (Photovac 2020, Photovac Inc., Waltham, MA 02451 USA) at the outlet of the glass bottle. Ozone was generated by a modified spark discharge generator (model AM 3000-2, Ozone Technology AB, Stockholm, Sweden) using pure O_2 , and was added to the ventilation air flow just downstream the inlet for terpene vapors and just upstream the inlet to the chamber. The added ozone concentration in the chamber was 40 ppb in the absence of terpene. In this way most of the reactions occurred inside the exposure chamber to ensure a fresh mixture of particles and gas-phase reaction products.

The aerosol generation was conducted in three-hour periods, repeated six times in the same way for both candle smoke and particles from terpene–ozone reactions, respectively, to ensure stability and reproducibility.

3.3. Methods of aerosol characterization

During the generation events, the particle mass concentration in the chamber was monitored with a Tapered Element Oscillating Microbalance (TEOM, Rupprecht & Patashnic Co Inc., Albany, NY, USA). A PM2.5 pre collector was used and the TEOM temperature was $50 \text{ }^\circ\text{C}$ for the candle smoke particle collection. For particles created by the terpene–ozone reactions, a naftion drier and a TEOM temperature of $30 \text{ }^\circ\text{C}$ was used due to the higher volatility of the particles. A Scanning Mobility Particle Sizer (SMPS, consisting of a ^{63}Ni bipolar charger, a CPC 3010, (TSI Inc, Shoreview, MN, USA) and a 28 cm Vienna type DMA) was used to measure particle number concentration and size distribution (10–650 nm). The aerosol flow rate in the SMPS was 0.5 lpm and sheath flow rate 5.0 lpm. Diffusion driers were installed in the sheath flow loop enabling measurements of the dry size distribution. The candle smoke aerosol composition was characterized for elements by PIXE (Particle Induced X-ray Emission Analysis), major ions by Ion-Chromatography and OC/EC (Organic Carbon/Elemental Carbon) analysis. PIXE samples were collected for 260 min on 47 mm nuclepore filters, pore size $0.4 \mu\text{m}$, at 4 lpm. OC/EC samples were collected for 180 min on 47 mm nuclepore filters, pore size $0.4 \mu\text{m}$, at 1.8 lpm. Two separate lines were used for the OC/EC analysis (Wierzbicka et al., 2005). One line consisting of a single Quartz filter (QF), and one line consisting of a Teflon filter followed by a Quartz filter (QB). The organic carbon found on the QB filter was subtracted from the OC found on the QF filter to correct for gas-phase adsorption of organics on the filter. The particles collected on Teflon filter was analyzed using ion chromatography.

Limonene was added to the chamber as described above for one hour in the absence of ozone. After this, samples of the VOCs in the chamber were collected as triplicates on adsorbent tubes packed with Carboxen 1000 for 3 min at a flow rate of 100 ml/min. The samples were analyzed using Thermal Desorption (Markes Unity, UK)–Gas Chromatography (Agilent 6890N, CA)–Mass Spectrometry (Agilent 5973, CA) (TD–GC–MS). The adsorbent tubes were desorbed at 300 °C for 10 min onto a coldtrap packed with Carboxen 1000 and held at –10 °C. During sample introduction to the column, the cold trap was heated for 2 minutes from –10 to 320 °C with a split ratio of 1.7:1. The GC was equipped with a 50 m, 0.32 mm inner diameter column (1.20 µm film thickness) and the GC oven conditions were 40 °C for 2 min; 5 °C/min up to 90 °C and hold 3 min; 10 °C/min up to 150 °C and hold 3 min; and finally 10 °C/min up to 300 °C and hold 5 min. The mass selective detector was operated in scan-mode from m/z 40–400. Mass spectra and retention times of the monoterpenes were confirmed with authentic standards. The limonene–ozone reaction was modeled in a simple chemical box model based on 200 gas-phase reactions as described in (Leunsaikul et al., 2005). The differential equations were solved numerically using Facsimile 4.0 (MCPA software, UK).

The chemical composition of particles created by terpene–ozone reactions was measured during one of the generation events by means of a High-Resolution Time of Flight Aerosol Mass Spectrometer (HR-ToF-AMS), (DeCarlo et al., 2006). The instrument was operated in V-mode. The data acquired were analyzed with IGOR pro 6.22 (Wavemetrics, Lake Oswego, OR), SQUIRREL 1.51 and PIKA 1.1. Elemental analysis was performed according to the algorithm described by Aiken et al. (2007).

The temperature, relative humidity, carbon dioxide levels and, in the case of terpene generation, ozone levels, were monitored on-line from the chamber.

4. Aerosol properties

4.1. Candle smoke

The candle smoke was generated using 6–10 candles, which gave a mean mass concentration in the exposure chamber of about 200 µg/m³ and a mean number concentration of about 800,000 cm⁻³. The mass and number concentration fluctuations during a typical 5 h generation event are shown in Fig. 4.

During any given candle smoke generation event, the chamber mass concentrations fluctuated ± 25–30%, reflecting the complex transient nature of the combustion process and soot formation. The almost inverse relationship between mass concentration and number concentration seen in Fig. 4 suggests that the chamber air was dominated by small, steady burn particles at some points in time and by soot particles at other. When the concentration of soot particles was increased at times of higher mass concentrations, the small nucleation mode particles that were dominating the number concentration (Fig. 5) were most likely lost to the larger soot agglomerates at a higher rate by coagulation. By carefully and continuously monitoring the chamber concentrations, the inlet flow rate of aerosol could be varied to adjust the chamber concentration towards the desired mean concentration. This was achieved by continuous monitoring and averaging of the mass concentration from start of the generation with a custom-built computer program (written in Labview, version 8.2, National Instruments, Austin, Texas, USA).

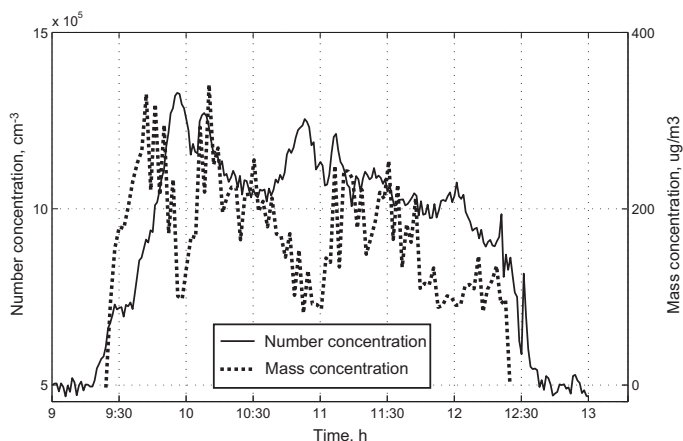

Fig. 4. The variation of candle smoke mass concentration and number concentration during a typical generation event. The event starts at 09:30 and finishes at 12:30.

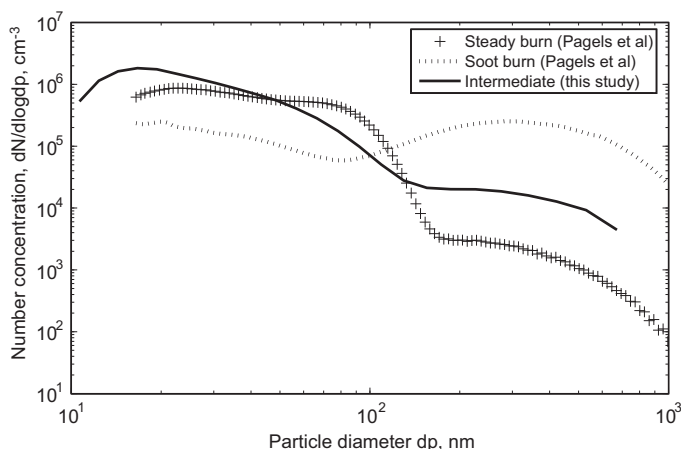

Fig. 5. Size distributions for candle smoke as a function burning mode. The continuous line shows a mean size distribution of the typical intermediate emission mode during a generation event, which here is compared to steady burn and soot burn from Pagels et al. (2009).

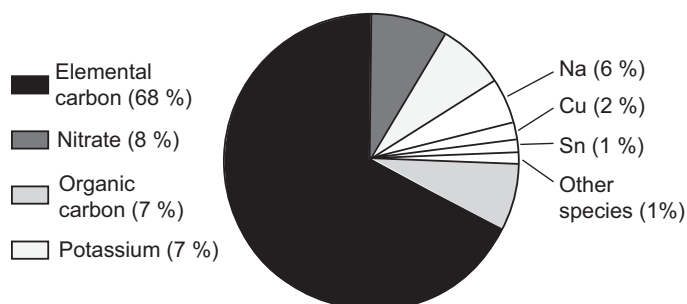

Fig. 6. Elemental composition (mass %) of the generated candle smoke.

In Fig. 5, the number size distribution during a typical generation event is compared to size distributions from the Pagels et al. (2009) study. It can be seen that in the present study we have an intermediate mode of burning during the candle smoke generation. The size distribution from this study, labeled “intermediate”, lies between that of a steady burn and a sooting burn in the experiments by Pagels et al. (2009). This intermediate emission mode is expected to be of high relevance to exposure to candle soot in indoor air as it resembles real conditions.

Reported emission factors from chamber studies by Fine et al. (1999), Zai et al. (2006) and Pagels et al. (2009) range from 0.3 to 2.4 mg/h for steady burn (0.9 mg/h for the candle type used here) and from 7.6 to 26 mg/h for sooting burn. By using the same box model (Koutrakis et al., 1991) as Pagels et al., the emission factor in this study was 2–3 mg/h per candle, which confirms an intermediate mode of burning, with smoke containing both small nucleation mode alkali salt particles and larger sized aggregated soot particles.

Chemical analysis by OC/EC, ion chromatography and PIXE shows that 68% of the generated candle aerosol mass consists of elemental carbon (soot), 7% of organic carbon (Fig. 6) and about 25% water-soluble salts and metals. The alkali salts (K- and Na-nitrates) most likely originates from additives to the wick. Cu most likely originates from blue color pigments vaporized in the combustion process, which condenses onto the fine particles. This is consistent with the bimodal candle smoke size distribution, with one peak at approximately 15 nm (consisting of inorganic material and metals) and one at approximately 200 nm, consisting mostly of elemental carbon.

4.2. Particles generated by terpene–ozone reactions

Upon limonene vapor reaction with ozone there is, as can be seen in Fig. 7, an immediate burst of nucleation mode particles (5–25 nm), which, due to condensation and coagulation processes, grow in size to 150 nm. In 0.5–1 h the system

reaches steady state when the coagulation rate equals the source rate, as described by Seipenbusch et al. (2008), with mainly a single mode of particles in the mean diameter range of 95–105 nm, as shown in Fig. 8.

After reaching steady state, the generation system delivers a stable aerosol regarding particle size, number and mass concentration. The average number and mass concentration during the generation events were $29500 \pm 3900 \text{ cm}^{-3}$ and $76 \pm 10 \mu\text{g}/\text{m}^3$.

GC–MS analysis showed that the limonene concentration reached in the chamber after one hour without addition of ozone was 160 ppb. After addition of ozone at steady state 33 ppb of limonene has reacted. With a formed SOA concentration of $76 \mu\text{g}/\text{m}^3$ this corresponds to an aerosol mass yield for limonene of about 0.5. Thus a significant fraction of the reacted limonene forms secondary organic aerosol but another significant part of the reacted species forms gas-phase species such as formaldehyde which also contributes to the resulting aerosol.

In the absence of limonene vapor the concentration of ozone was 40 ppb. A large fraction of the ozone is consumed by the terpenes, leaving a residual ozone level in the exposure chamber of around 18 ppb. Since ozone itself is an airway irritant, a low ozone level inside the chamber is of importance if the generated aerosol is to be used for exposure studies. The chamber ozone level is low compared to average indoor ozone concentrations in the US, 30–60 ppb, as reported by Zang and Liou (1994) and Rohr et al. (2003). However it should be noted that ozone concentrations indoors can be close to zero in some cases, because of the large surfaces area with high deposition velocities, and low air exchange rates for naturally ventilated buildings. Weschler (2006) found that typical indoor concentrations are 10–50% of outdoor levels.

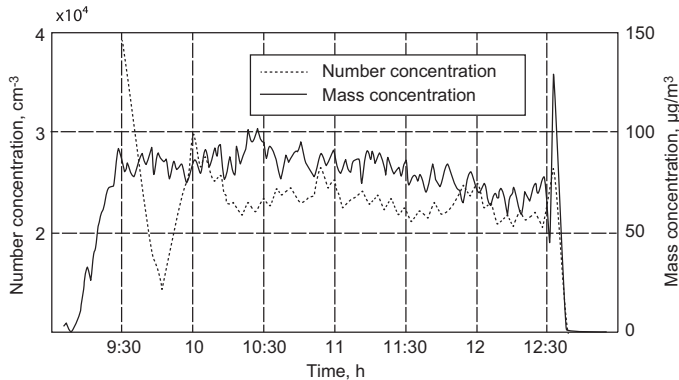

Fig. 7. The variation of terpene–ozone particle mass concentration and number concentration during a typical generation event. Ozone and aerosol generation starts at 9:00. The event starts at 09:30 and finishes at 12:30.

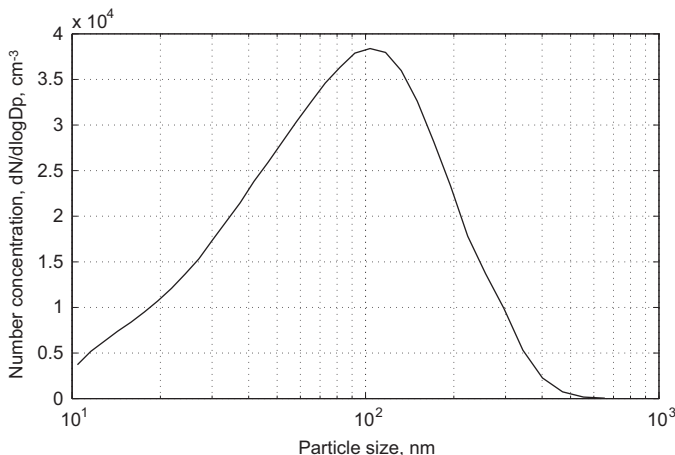

Fig. 8. Mean size distribution of the particles generated by terpene–ozone reactions.

Chemical analysis (GC–MS) of the adsorbent tubes showed that limonene accounts for more than 90% (volume) of the detected VOCs in the absence of ozone. Three other monoterpenes, i.e. camphene, α -pinene and β -pinene, were present in minor amounts. In terms of GC–MS peak area the generation events were 92% limonene, 4% α -pinene, 2% camphene and 2% β -pinene. Since limonene is much faster reacting with ozone than the other compounds, the aerosol was clearly dominated by limonene- O_3 and limonene-OH reaction products (Atkinson & Arey, 2003). By use of the model, we estimate the OH radical concentration in the chamber to be $3 \times 10^9 \text{ cm}^{-3}$ for the conditions described below when the reaction is in steady-state. According to the model, the most abundant gas-phase species were formaldehyde (5 ppb), keto-limonene (4-acetyl-1-methyl-cyclohexene; 2 ppb), and limononaldehyde (3-isopropyl-6-oxo-heptanal; 3 ppb). The low concentrations of these products are not expected to cause any health effect themselves.

The composition of the secondary organic aerosol from terpene–ozone reactions is complex. With the HR-ToF-AMS we quantified the sum of essentially all organic particle phase compounds. Due to fragmentation during ionization, single organic compounds cannot be quantified with this technique. A high resolution aerosol mass spectrum, where the organic fragments have been divided into categories dependent on their composition, is given in Fig. 9. The major categories were CH (fragment containing just C and H), CHO1 (containing C, H and one O atom), CHOgt1 (greater than) 1 (containing C, H and > 1 O) and OH (containing just O and H). By adding up all detected fragments in the high resolved aerosol mass spectra quantitative elemental analysis can be obtained (Aiken et al., 2007). The results show that on a molar basis the aerosol consists of 52% hydrogen, 36% carbon and 12% oxygen. The O:C ratio is 0.33 which is significantly higher than that found in fresh diesel exhaust primary organic aerosol, but lower than that commonly found for secondary organic aerosol in ambient air (Ng et al., 2011). The common AMS fragments CO_2^+ ($m/z=44$) and $\text{C}_2\text{H}_3\text{O}^+$ ($m/z=43$) are markers of carboxylic acid and other carbonyl groups (e.g. aldehydes) respectively. In the terpene–ozone generated aerosol the relative fraction of $\text{C}_2\text{H}_3\text{O}^+$ is more than double the fraction of CO_2^+ and thus the fraction of carboxylic acid groups in the aerosol is relatively low which is also reflected by the moderate O:C ratio. The mass spectra found in this study is similar to that found by Zang et al. (2006) who use a unity resolution Q-AMS to investigate limonene oxidation by ozone in a smog chamber in the presence and absence of NO_x . These elemental analysis results are plotted on a mass basis in Fig. 10 for comparison with the composition of the candle smoke.

The resulting particle mass concentration in the exposure chamber was approximately $75 \mu\text{g}/\text{m}^3$. During the 3 h generation, assuming a person breathes 8 lpm, a human test subject would be exposed to $100 \mu\text{g}$ of particles generated by terpene–ozone reactions. Nazaroff et al. (2006) found that, during moderate outdoor ozone levels, a person doing their normal day-to-day house cleaning will inhale an average of $35 \mu\text{g}/\text{day}$ of SOAs, mainly as ultrafine particles, as a consequence of ozone reacting with constituents of the cleaning agents.

The TEOM temperature is important for the vaporization of water and semi-volatile species from the particles collected on the TEOM filter. Ultimately water should be evaporated and the organics kept on the TEOM filter. To minimize these potential artifacts we used different measurement strategies dependent on particle characteristics. For the terpene–ozone reaction products which is an organic dominated semi-volatile aerosol with low water uptake we used a reduced TEOM

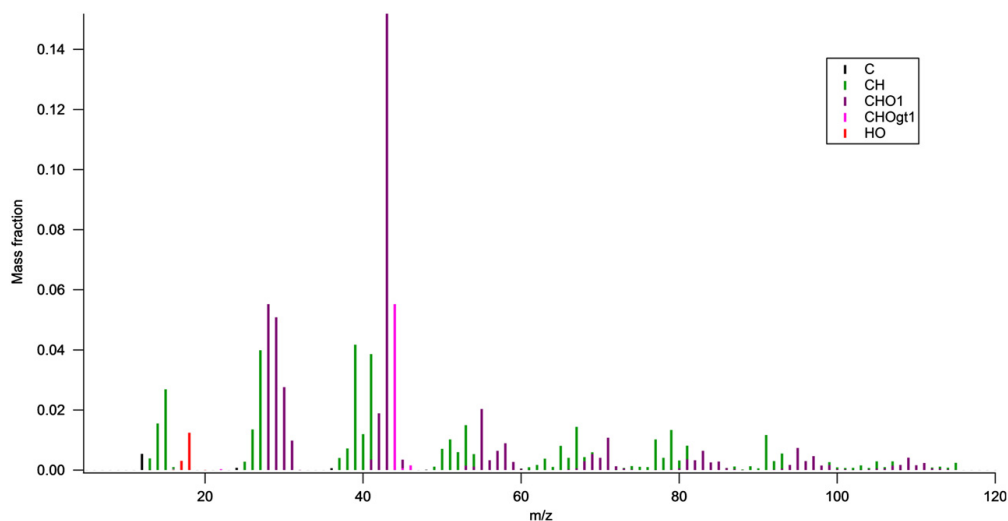

Fig. 9. High resolution mass spectra of the organic aerosol formed by terpene–ozone reactions recorded with the HR-ToF-AMS. The detected fragments have been divided into a set of families dependent on their elemental composition.

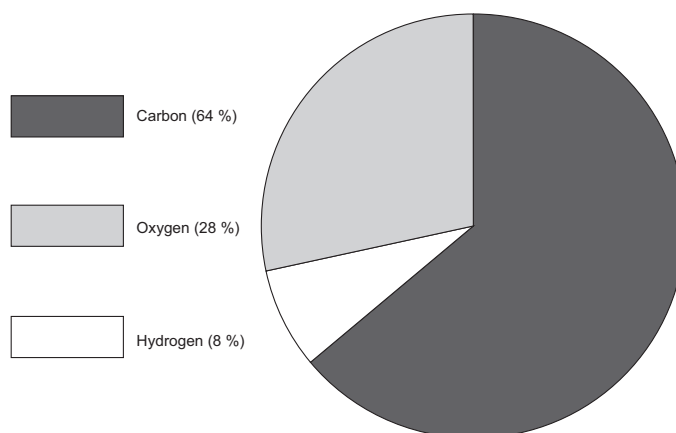

Fig. 10. Elemental composition (mass %) of the particles generated by terpene-ozone reactions.

Table 1

Concentration and air quality in chamber during generation events. Standard deviations are given for the inter-experiment variation, i.e. standard deviation of means.

	Number of 3 h generation events	Number concentration \pm Std (cm^{-3})	Mass concentration \pm Std ($\mu\text{g}/\text{m}^3$)	Relative humidity \pm Std (%)	Temperature \pm Std ($^{\circ}\text{C}$)	AER (h^{-1})	$\text{O}_3 \pm$ Std (ppb)
Candle smoke	6	$8 \times 10^5 \pm 2 \times 10^5$	200 ± 30	33 ± 1.6	23 ± 0.3	5.8	–
Limonene + ozone	6	$3 \times 10^4 \pm 4 \times 10^3$	80 ± 10	33 ± 1.5	23 ± 0.6	4.5	18 ± 4.6

temperature of 30°C , while for the candle smoke particles for which the semi-volatile organic fraction was small while a major fraction consisted of alkali salts with a high water affinity we chose to use the standard TEOM temperature of 50°C . The constant RH conditions ensured that measured differences in PM are not attributed to water evaporation from the filter or collected particles.

A summary of the environment in the chamber during the 3 h long generation events is shown in Table 1.

5. Summary and conclusions

Well controlled aerosol generation and detailed aerosol characterization are cornerstones in performing human (or animal) exposure studies. We have shown that aerosols in home environments could be reproduced with a particle concentration, size distribution and composition that compares well to those of field studies and of calculations. The aerosols could be generated and delivered to the exposure chamber in a well-controlled and stable manner, indicating that the system is suitable for both for aerosol characterization and for human exposure studies.

One of the main issues when creating generation systems for human exposure of common indoor aerosols is to decide what a “realistic aerosol” is. Many studies have been made in laboratory settings, characterizing single aerosol sources, such as the work of Afshari et al. (2005) and Wallace (2006). Studies like these can be used to compare chemical composition, size distribution and emission factors, for example. An estimate of what concentration levels of a particular source that can occur in a home is needed, to be able to decide the target level of the laboratory generated aerosol. If the generated aerosol is to be used for human exposure studies, which occurs during a limited amount of time (normally a couple of hours) it is desired to achieve levels higher than everyday exposure, but not so high that they are unrealistic or unethical. However, when it comes to deciding what source concentrations are realistic in real life, one faces the challenge of measuring a single source against the background of both ambient particles and particles created by other human activities. Candle burning, for example, is often done in combination with cooking, which makes it very difficult to appportion the measured aerosol concentration to the relevant source. One way of at least get an estimation, is to conduct continuous measurements with high time resolution in combination with activity logs, preferably in several homes, and simply hope to catch one or several occasions where the source in question is the single present. The more such studies are conducted, the more data will be available for generation and exposure purposes. In this work, there was access to such

measurements made in homes (e.g. Wierzbicka, 2008) which were partially used when deciding on target concentrations. As shown, a mass balance model can, together with emission factors, also be a tool for setting realistic concentration levels.

The results show that realistic concentrations suitable for human exposure studies of two different types of commonly abundant aerosols could be obtained.

The flexibility of the generation and chamber system and the ability of monitoring several exposure parameters indicate that it can be also used for generating and characterizing aerosols other than those described (e.g. Isaxon et al., 2013; Nordin et al., 2012).

Acknowledgments

This research was funded by FAS (Swedish Council for Working Life and Social Research), FORMAS (the Swedish Research Council for Environment, Agricultural Sciences and Spatial Planning), and METALUND (Centre for Medicine and Technology for Working Life and Society). PIXE analysis was performed at Division of Nuclear Physics, Lund University, by Ms Britt Jönsson, and results communicated by Professor Jan Pallon.

References

- Afshari, A., Matson, U., & Ekberg, L.E. (2005). Characterization of indoor sources of fine and ultrafine particles: a study conducted in a full-scale chamber. *Indoor Air*, 15, 141–150.
- Aiken, A.C., DeCarlo, P.F., & Jimenez, J.L. (2007). Elemental analysis of organic species with electron ionization high-resolution mass spectrometry. *Analytical Chemistry*, 79, 8350–8358.
- Atkinson, R., & Arey, J. (2003). Gas-phase tropospheric chemistry of biogenic volatile organic compounds: a review. *Atmospheric Environment*, 37, 197–S219.
- DeCarlo, P.F., Kimmel, J.R., Trimborn, A., Northway, M.J., Jayne, J.T., Aiken, A.C., Gonin, M., Fuhrer, K., Horvath, T., Docherty, K., Worsnop, D.R., & Jimenez, J.L. (2006). Field-deployable, high-resolution, time-of-flight aerosol mass spectrometer. *Analytical Chemistry*, 78, 8281–8289.
- Destailhats, H., Lunden, M.M., Singer, B.C., Coleman, B.K., Hodgson, A.T., Weschler, C.J., & Nazaroff, W.W. (2006). Indoor secondary pollutants from household product emissions in the presence of ozone: a bench-scale chamber study. *Environmental Science and Technology*, 40(14), 4421–4428.
- Fiedler, N., Laumbach, R., Kelly-McNeil, K., Lioy, P., Fan, Z.-H., Zhang, J., Ottenweller, J., Ohman-Strickland, P., & Kipen, H. (2005). Health effects of a mixture of indoor air volatile organics, their ozone oxidation products and stress. *Environmental Health Perspectives*, 113(11), 1542–1548.
- Fine, P.M., Cass, G.R., & Simoneit, B.R.T. (1999). Characterization of fine particle emissions from burning church candles. *Environmental Science and Technology*, 33, 2352–2362.
- He, C., Morawska, L., & Gilbert, D. (2005). Particle deposition rates in residential houses. *Atmospheric Environment*, 39, 3891–3899.
- Hussein, T., Glytsos, T., Ondracek, J., Dohanyosova, P., Zdimal, V., Hameri, K., Lazaridis, M., Smolik, J., & Kumala, M. (2006). Particle size characterization and emission rates during indoor activities in a house. *Atmospheric Environment*, 40, 4285–4307.
- Isaxon, C., Dierschke, K., Pagels, J., Löndahl, J., Gudmundsson, A., Hagerman, I., Berglund, M., Wierzbicka, A., Assarsson, E., Andersson, U.B., Jönsson, B.A.G., Messing, M.E., Nielsen, J., & Bohgard, M. (2013). A novel system for source characterization and controlled human exposure to nanoparticle aggregates generated during gas-metal arc welding. *Aerosol Science and Technology*, 47(1), 52–59.
- Kleno, J., & Wolkoff, P. (2004). Changes in eye blink frequency as a measure of trigeminal stimulation by exposure to limonene oxidation products, isoprene oxidation products and nitrate radicals. *International Archives of Occupational and Environmental Health*, 77, 235–243.
- Koutrakis, P., Brauer, M., Briggs, S.L.K., & Leaderer, B.P. (1991). Indoor exposures to fine aerosols and acid gases. *Environmental Health Perspectives*, 95, 23–28.
- Lamarena, R.B., Jung, S.-G., Bae, G.-N., & Lee, W. (2007). The formation of ultra-fine particles during ozone-initiated oxidations with terpenes emitted from natural paint. *Journal of Hazardous Materials*, 141, 245–251.
- Larosa, L.B., Buckley, T.J., & Wallace, L.A. (2002). Real-time indoor and outdoor measurements of black carbon in an occupied house: an examination of sources. *Journal of the Air and Waste Management Association*, 52, 41–49.
- Leunsakul, S., Jeffries, H.E., & Kamens, R.M. (2005). A kinetic mechanism for predicting secondary aerosol formation from the reactions of D-limonene in the presence of oxides of nitrogen and natural sunlight. *Atmospheric Environment*, 39, 7063–7082.
- Maricq, M.M. (2007). Chemical characterization of particulate emissions from diesel engines: a review. *Journal of Aerosol Science*, 38(11), 1079–1118.
- Matson, U. (2005). Indoor and outdoor concentrations of ultra fine particles in some Scandinavian rural and urban areas. *Science of the Total Environment*, 343, 169–176.
- Nazaroff, W.W., Coleman, B.K., Destailhats, H., Hodgson, A.T., Liu, D.-L., Lunden, M.M. (2006). *Indoor Air Chemistry: Cleaning Agents, Ozone and Toxic Air Contaminants*. Report 01-336. Sacramento, CA: California Air Resources Board, pp. 145–156.
- Ng, N.L., Canagaratna, M.R., Jimenez, J.L., Chhabra, P.S., Seinfeld, J.H., & Worsnop, D.R. (2011). Changes in organic aerosol composition with aging inferred from aerosol mass spectra. *Atmospheric Chemistry and Physics*, 11, 6465–6474.
- Nordin, E.Z., Eriksson, A.C., Roldin, P., Nilsson, P.T., Carlsson, J.E., Kajos, M.K., Hellén, H., Wittbom, C., Rissler, J., Löndahl, J., Swietlicki, E., Svenningsson, B., Bohgard, M., Kulmala, M., Hallquist, M., & Pagels, J. (2012). Secondary organic aerosol formation from gasoline passenger vehicle emissions investigated in a smog chamber. *ACP Discussions*, 12, 31725–31765. <http://dx.doi.org/10.5194/acpd-12-31725-2012>.
- Pagels, J., Wierzbicka, A., Nilsson, E., Isaxon, C., Dahl, A., Gudmundsson, A., Swietlicki, E., & Bohgard, M. (2009). Chemical composition and mass emission factors of candle smoke particles. *Journal of Aerosol Science*, 40, 193–208.
- Rohr, A.C., Weschler, C.J., Koutrakis, P., & Spengler, J.D. (2003). Generation and quantification of ultrafine particles through terpene/ozone reaction in a chamber setting. *Aerosol Science and Technology*, 37, 65–78.
- Salvolainen, K., Alenius, H., Norppa, H., Pylkkänen, L., Tuomi, T., & Kasper, G. (2010b). Risk assessment of engineered nanomaterials and nanotechnologies—a review. *Toxicology*, 269, 92–104.
- Savolainen, K., Pylkkänen, L., Norppa, H., Falk, G., Lindberg, H., Tuomi, T., Vippola, M., Alenius, H., Hämeri, K., Koivisto, J., Brouwer, D., Mark, D., Bard, D., Berges, M., Jankowska, E., Posniak, M., Farmer, P., Singh, R., Krombach, F., Bihari, P., Kasper, G., & Siepenbusch, M. (2010a). Nanotechnologies, engineered nanomaterials and occupational health and safety—a review. *Safety Science*, 48, 957–963.
- Schneider, T., Sundell, J., Bischof, W., Bohgard, M., Cherrie, J.W., Clausen, P.A., Dreborg, S., Kildesø, J., Kjærsgaard, S.K., Løvik, M., Pasanen, P., & Skyberg, K. (2003). 'EUROPART'. Airborne particles in the indoor environment. A European interdisciplinary review of scientific evidence on associations between exposure to particles in buildings and health effects. *Indoor Air*, 13, 38–48.
- Seipenbusch, M., Binder, A., & Kasper, G. (2008). Temporal evaluation of nanoparticle aerosols in workplace exposure. *Annals of Occupational Hygiene*, 52(8), 707–716.
- Singer, B.C., Destailhats, H., Hodgson, A.T., & Nazaroff, W.W. (2006). Cleaning products and air fresheners: emissions and resulting concentrations of glycol ethers and terpenoids. *Indoor Air*, 16, 179–191.

- Sorensen, M., Loft, S., Andersen, H.V., Nielsen, O.R., Skovgaard, L.T., & Knudsen, L.E. (2005). Personal exposure to PM 2.5, black smoke and NO₂ in Copenhagen: relationship to bedroom and outdoor concentrations covering seasonal variation. *Journal of Exposure Analysis and Environmental Epidemiology*, 15, 413–422.
- Wainman, T., Zhang, J.F., Weschler, C.J., & Liyo, P.J. (2000). Ozone and limonene in indoor air: a source of submicron particle exposure. *Environmental Health Perspectives*, 108, 1139–1145.
- Wallace, L. (2006). Indoor sources of ultrafine and accumulation mode particles: Size distributions, size-resolved concentrations, and source strengths. *Aerosol Science and Technology*, 40, 348–360.
- Weschler, C.J. (2006). Ozone's impact on public health: contributions from indoor exposures to ozone and products of ozone-initiated chemistry. *Environmental Health Perspectives*, 114(10), 1489–1496.
- Wierzbicka, A. (2008). What are the characteristics of airborne particles that we are exposed to? Ph.D. Thesis, ISBN 978-91-628-7443-8.
- Wierzbicka, A., Lillieblad, L., Pagels, J., Strand, M., Gudmundsson, A., Gharibi, A., Swietlicki, E., Santani, M., & Bohgard, M. (2005). Particle emissions from district heating units operating on three commonly used biofuels. *Atmospheric Environment*, 39, 139–150.
- Wolkoff, P., Clausen, P.A., Larsen, S.T., Hammer, M., & Damgård-Nielsen, G. (2012). Airway effects of repeated exposures to ozone-initiated limonene oxidation products as model of indoor air mixtures. *Toxicology Letters*, 209(2), 166–172.
- Zai, S., Huang, Z., & Wang, J.S. (2006). Studies on the size distribution, number and mass emission factors of candle particles characterized by modes of burning. *Journal of Aerosol Science*, 37, 1484–1496.
- Zang, J., Huff Hartz, K.E., Pandis, S.N., & Donahue, N.M. (2006). Secondary organic aerosol formation from limonene ozonolysis: homogeneous and heterogeneous influences as a function of NO_x. *Journal of Physical Chemistry A*, 110(38), 11053–11063.
- Zang, J., & Liyo, P.J. (1994). Ozone in residential air: concentrations, I/O ratios, indoor chemistry, and exposures. *Indoor Air*, 4, 95–105.

Article II



A Novel System for Source Characterization and Controlled Human Exposure to Nanoparticle Aggregates Generated During Gas–Metal Arc Welding

C. Isaxon,¹ K. Dierschke,² J. Pagels,¹ J. Löndahl,¹ A. Gudmundsson,¹
I. Hagerman,³ M. Berglund,³ A. Wierzbicka,¹ E. Assarsson,² U. B. Andersson,²
B. A. G. Jönsson,² M. E. Messing,⁴ J. Nielsen,² and M. Bohgard¹

¹*Department of Design Sciences, Ergonomics and Aerosol Technology, Lund University, Lund, Sweden*

²*Department of Medicine, Occupational and Environmental Medicine, Lund University, Lund, Sweden*

³*Department of Medicine, Huddinge, Karolinska Institutet, Stockholm, Sweden*

⁴*Department of Physics, Solid State Physics, Lund University, Lund, Sweden*

The aim of this study was to achieve a method to perform detailed characterization and human exposure studies of nanosized and nanostructured aerosol particles. The source chosen was mild steel, active gas, arc welding fume. The setup consisted of a generation chamber, where welding can be performed, connected to an airtight stainless steel 22 m³ exposure chamber. Instrumentation, consisting of a tapered element oscillating microbalance, a scanning mobility particle sizer, and a sampler for electron microscopy and particle-induced X-ray emission analysis was connected to the stainless steel chamber. The feasibility of the system for human exposure studies was evaluated by exposing 31 human volunteers, in groups of three, to a test aerosol containing 1 mg/m³ welding fumes and to conditioned, filtered air. The results show that an aerosol that accurately represents dilute welding fume exposures that occur in workplaces can be produced in a controlled manner, and that the experimental setup can be used for 6 h, double-blind, exposures of human subjects. Particle mass concentration levels could be varied from <5 μg/m³ to more than 1000 μg/m³. Fumes from metal active gas welding showed a unimodal size distribution with a mean mobility diameter of 160 nm, transmission electron microscopy showed aggregates with a clearly nanosized structure.

1. INTRODUCTION

The objectives of this research were to design a system for controlled characterization and human exposure studies of nanosized/nanostructured airborne particles from thermal processes, occurring in industrial workplaces, and to validate the system by comparison to real workplaces where welding occurs.

Numerous studies indicate that there is a correlation between exposure to airborne particles and health problems (Pope et al. 2002; Li et al. 2003; Brook and Rajagopalan 2010). People spend a major part of their time in the workplace, so the health effects of particle exposures in these environments are of special interest. Airborne nanosized (having one dimension <100 nm) and nanostructured particles are of particular concern, since their health effects and the mechanisms driving these effects are not fully understood (Gil et al. 2010). Some studies, though, provide a basis for better theoretical understanding of their exposure, uptake, and kinetics. A strong hypothesis is that the relatively large particle number and surface area per unit mass of these particles are likely to decrease the ability of the macrophages to phagocytose them, and increase their uptake by epithelial cells. The particles can, hence, end up in the interstitium and cause inflammation there (Donaldson et al. 1998). Comparing the inflammogenicity of carbon black with ultrafine carbon black when instilled into rat lungs, Brown et al. (2000) found that the ultrafine carbon black particles induced more inflammation and suggested that the difference may be accounted for by increased surface area or particle number. Kreyling et al. (2002) showed translocation of radiolabeled iridium particles (15 and 80 nm) within a week after inhalation to systemic circulation and liver, spleen heart, and brain in rats. The translocated fraction was one order of magnitude larger for the 15 nm particles than for the 80 nm particles. An inhalation study, using rats, by Oberdorster et al. (2004) showed increasing particle levels of 36 nm ¹³C

Received 22 March 2012; accepted 18 July 2012.

The authors thank Swedish Council for Working Life and Social Research (FAS), Swedish Research Council for Environment, Agricultural Sciences and Spatial Planning (FORMAS), and Centre for Medicine and Technology for Working Life and Society (METALUND) for their support.

Address correspondence to C. Isaxon, Department of Design Sciences, Ergonomics and Aerosol Technology, Lund University, Sölvegatan 26, Lund 22362, Sweden. E-mail: christina.isaxon@design.lth.se

particles in the olfactory bulb throughout a 7-day postexposure period indicating that uptake via sensory nerve endings constitutes a clearance pathway to the central nervous system. Oberdorster et al. (2011) also showed particle translocation to the blood compartment from the GI-tract of whole-body exposed rats. The cardiovascular effects of inhalation of nanosized particles have been studied by Pekkanen et al. (2002), this study found a correlation between ultrafine particulate air pollution and ST segment depression during exercise (indicating increased risk of myocardial ischemia) in human test subjects.

There is a long tradition of exploring the health effects of dusts and fumes in industrial environments. Most exposure measurements in these studies, as well as threshold limit values, have been based on mass concentrations. Very often the mass of nanoparticles is insignificant compared to the mass of coarse particles in industrial workplaces, yet there can be very high number concentrations of nanosized and nanostructured particles present. There is an ongoing debate on what metric is most relevant for assessment of exposure risk. In addition to number concentration, size, shape, surface area, and composition are examples of measurable parameters which can be assumed to influence particle toxicity (Warheit et al. 2007; Trout and Schulte 2010). As the development of new instruments to analyze nanoparticles progresses, more extensive studies of nanoparticles in the workplace are becoming possible. Renewed study of these environments and exposures, using modern instrumentation, can give us better knowledge of the health effects of specific aerosol properties and characteristics. There is a need for well-designed toxicological studies of fine ($<2.5 \mu\text{m}$) and ultrafine ($<100 \text{ nm}$) particle exposure in humans.

Welding is a major source of fine and ultrafine particles in working environments worldwide. In the United States, alone there are nearly 0.5 million people performing welding and cutting operations full-time, and an additional 1–2 million workers who weld intermittently (Jenkins 2003). In Europe 837,000 people work as full-time welders and 1 million more weld intermittently (Björn Hedlund 2011, General Manager of European Welding Association (EWA), personal communication). The total amount of smoke emitted from the welding industry worldwide is estimated to 5000 tons/year (Redding 2002). Very high exposure concentrations can be obtained when welding; levels of several mg/m^3 are not uncommon as averages for personal exposures over a workday. Furthermore, particles from welding processes are enriched with metal oxides, which are potentially toxic. The significance of welding particles as examples of large-scale exposure to nanosized particles has previously been demonstrated by Bohgard et al. (1979) where clear indications of particles from shielded metal arc welding washed with buffered water solution show disintegration of the agglomerates into numerous metal-containing “free” nanoparticles.

Welding fume particles are formed when molten metal at the end of an electrode emits vapor that mixes with the shield gas and is transported from the arc temperature of well above 3000 K (boiling point of iron) to room temperature (Jenkins 2003).

Particles nucleate and grow by condensation to form primary particles (0.01–0.10 μm) followed by growth through coagulation. As the temperature of the plume decreases, the welding fume particles quickly form complex, chain, aggregates between 100 and 300 nm in length. The variations in both primary particle size and aggregate size can be large (Jenkins 2003).

The most frequently used welding methods are shielded metal arc welding (SMAW) and gas metal arc welding (GMAW). The latter can be divided in metal inert gas (MIG) and metal active gas (MAG), depending on the composition of the shielding gas. By creating a microclimate around the welding point, a flux or gas protects the molten metal from oxidation, thus shielding it from the oxygen in the surrounding atmosphere. The type of shielding gas depends on the substrate. However, a welding process is often optimized by using a mixture of the two types of gases (active and inert). The composition of the electrode is matched to that of the substrate, so that a welding joint with mechanical properties similar to the substrate is obtained. It has been shown that fume composition is reasonably independent of the substrate material itself and that the welding fumes are mainly composed of species from the electrode material (Antonini et al. 2006). The substrate seems to influence the fume composition only if covered with oil, paint, or any similar substance (Quimby and Ulrich 1999).

The emerging applications of nanotechnology require precautions with respect to inhalable nanosized and nanostructured particles. Some industrial processes, including welding, create air borne nanoparticles (Tabrizi et al. 2010). Particles from industrial environments like welding workplaces can be used to increase the understanding of toxicological mechanisms and in risk analysis.

2. THE METHODOLOGY

The methodology developed for this study can be divided into three parts: (i) measurement of welding fume aerosol in real world workplace environments and literature review, (ii) generation of an aerosol with similar properties in controlled laboratory settings, and (iii) creation of a chamber environment suitable for controlled characterizations and human exposure studies.

The study was approved by the local ethics committee according to the declarations of Helsinki and an informed consent was obtained from all subjects prior to exposure.

2.1. Aerosol Characterization in Workplaces

Welding aerosols were characterized by conducting extensive measurements in three welding workshops in the south of Sweden. A wide range of measurement instruments were used, described in detail in Isaxon et al. (2009). Samples were taken at two different points in each of the workshops. The first sampling point was at a 2 m height, at least 5 m distance from the nearest known source of fine and ultrafine particles, using a PM10 inlet. The purpose of this was to sample the workshop background air.

The second sampling point was in a freshly generated welding plume at a distance of 5–20 cm above the welding point using a sampling probe immediately connected to a two-stage ejector dilution system. These in-plume measurements provided the signature size distribution and composition of GMAW fumes. With these measurements, the mass and number concentrations, size distribution, and chemical composition in both the welding plume and in the background air were defined.

From the workplace measurements, it was found that welding and other activities were executed for periods of nonuniform length and frequency; hence, background concentrations fluctuated considerably during a workday. PM10 mass concentration in the background zone during working hours could typically vary throughout the day between 100 $\mu\text{g}/\text{m}^3$ during periods of low activity to 3000 $\mu\text{g}/\text{m}^3$ or above during intense periods. Average mass concentrations of 1–3 mg/m^3 were common. The respirable dust, measured for selected welders by personal filter samplers (with a 50% cut-off at 4 μm) placed in the breathing zone, varied between 0.6 and 3.4 mg/m^3 . In particle-induced X-ray emission (PIXE) analysis of impactor samples, MAG welding typically showed a unimodal size distribution with a mass median aerodynamic diameter of around 200 nm (Isaxon et al. 2009). Chemical analysis showed that the elemental particle composition was dominated by iron, while the manganese fraction increased with size, suggesting that manganese condenses onto existing particles at lower temperatures in the formation process (Isaxon et al. 2009). Further, the fraction of nickel and chromium were very low, as expected for welding in mild steel.

2.2. Choice of Particle Concentrations for Controlled Exposure Studies

The welding fume generated by MAG welding in mild steel consists, in the size range between 150 and 500 nm, of approximately 20% (mass) of manganese (Isaxon et al. 2009). Manganese is toxic and has been linked to impaired motor skills and cognitive disorders. High exposure to airborne manganese has been shown to cause a form of neurodegeneration similar to Parkinson's disease called "manganism" among people working with metallurgical processes (Crossgrove and Zheng 2004). In Sweden, the 8 h occupational threshold limit value for manganese is 100 $\mu\text{g}/\text{m}^3$. The target welding fume mass concentration for the human exposure study was set to 1000 $\mu\text{g}/\text{m}^3$ as a mean which is equivalent to a manganese concentration of 85 $\mu\text{g}/\text{m}^3$ for the selected electrode and welding technique.

2.3. Aerosol Generation for Human Exposure Studies

A laboratory generation system for welding fumes was developed using a welding system frequently utilized in the welding industry (Kemppi, Kempomig 350, Lahti, Finland) with a 1 mm electrode (ESAB, Aristorod 12.50, Gothenburg, Sweden), which is one of the most commonly used electrodes from this manufacturer for mild steel welding. The nozzle feeding rate was 3 cm/s. This electrode has relatively high levels of manganese and silicon (1.2% and 0.7%, respectively), making it useful for

welding on clean mild steel but also for welding over moderate to high levels of rust and mill scale. As shielding gas an Ar/CO₂ mixture (82% Ar, 18% CO₂) (Air Liquide, Arcal MAG, Paris, France) at a flow rate of 12 lpm was used. Mild steel was chosen as the welding substrate because it is commonly used in the industry. Welding was performed at 125 A, 5.5 V. To create an average fume particle concentration of 1000 mg/m^3 , a welding pulse of 3 min was generated followed by a nonwelding period of 20 min. This kind of nonuniform exposure resembles real-life work situations. Continuous monitoring and averaging of the mass concentration with a custom-built computer program (written in Labview, version 8.2, National instruments, Austin, TX, USA) made it possible to increase or decrease the welding time of each welding pulse, and the pulse frequency, toward the desired mean concentration. The person performing the welding was trained by a professional welder. Welding was conducted in straight lines at a uniform pace. Care was taken not to let the welding joints cross each other, so that welding was always carried out on a clean mild steel surface.

The aerosol was generated in a 1.33 m³ chamber made of glass and stainless steel (bottom surface area 0.81 m²) placed in an adjacent room. An inlet for clean pressurized air, filtered by a high efficiency particle arrester (HEPA) filter and an active carbon filter was placed in the bottom to provide a steady controlled flow through the generation volume. Welding fumes were captured by an extractor hood placed directly above (0.3 m) the aerosol source with an inlet area of 0.39 m × 0.16 m. The hood was connected to a copper pipe, 3 cm in diameter and 8.25 m in length, through which the aerosol by means of an air amplifier (Coval, M10C, Raleigh, NC, USA) was transported into the chamber. Pressurized air was injected in the amplifier, perpendicular to the aerosol flow. An air amplifier is constructed such that the pressurized airflow bends 90° to follow the interior surface of the amplifier (due to the Coanda effect), and thus creates a low pressure area in the amplifier volume. The low pressure entrains the aerosol and produces high velocity outlet flows. The amplifier drew 400 lpm of aerosol from the generation volume and delivered 500 lpm after dilution with filtered pressurized air at 4 Bar (400 kPa) of operating pressure. These flow rates could be varied by adjusting the operating pressure of the air amplifier. A muffler was placed after the air amplifier, just prior to the chamber inlet, so that the sound of the amplifier would not reveal if it was particle exposure or blank at a given exposure event. The welding fume was further diluted by air from the conditioning system (described in the next section) before entering the exposure chamber. The extractor hood and air amplifier were used to keep the residence time of the aerosol in the generation system at a minimum (approximately 2 s). By this, aerosol dynamic processes, mainly coagulation that easily occurs with high number concentrations and long residence time, could be avoided. Coagulation alters the number size distribution toward larger and fewer particles, neither of which is desired in these exposure experiments. In principle, efforts were made to achieve a dilution process (residence time and dilution

ratio) relevant for that occurring in realistic industrial environments when the fume travels from generation point to breathing zone. A cyclone was placed just prior to the dilution of welding fume with air from the air conditioning unit, downstream the air amplifier, in order to avoid release of particles deposited in pipe bends and in the amplifier itself into the chamber. Such mechanically generated particles would mostly be larger than $2\text{--}3\ \mu\text{m}$, and are not desirable in the exposure chamber. The initial relative concentration fluctuations extracted from the hood could be monitored with an optical aerosol instrument (TSI, Dust-Trak 8520, Shoreview, MN, USA). By opening a valve in the extractor hood, the concentration of aerosol transported out of the generation volume could be varied. The generation volume was protected from contamination from the surrounding air by a hatch, which was kept closed at all times, except when welding was conducted. Calculations show that particles from ambient air that may leak into the generation volume during welding contributed to the exposure chamber particle concentration by less than $0.2\ \mu\text{g}/\text{m}^3$.

The mean residence time of the diluted fume in the exposure chamber was 10 min (due to an air exchange rate of 5.8/h) and, therefore, the exposure is most relevant for relatively fresh background aerosol at a workplace.

2.4. The Exposure Chamber

The human exposure chamber (Figure 1) is a $21.6\ \text{m}^3$ room where all interior surfaces except for a window of $0.8\ \text{m}^2$ are

made out of stainless steel. When the doors are closed, the system is under a slight positive pressure.

The room is entered via an antechamber ($3.1\ \text{m}^3$) with airtight doors. The chamber is supplied with air through a separate, custom-built air conditioning system by which airflow, temperature, and relative humidity are controlled. After being filtered inside the conditioning system, the chamber air supply passes through an additional activated carbon filter and an ultra-low penetration air filter, before entering the exposure chamber at roof level. The exposure aerosol is premixed with the supply air and diluted into the clean air stream just above the chamber inlet at roof level. The chamber air exhaust flow is controlled using a variable fan which is also used for achieving a desired slight overpressure (typically 10 Pa or just below) inside the chamber, to make sure no particles from the surrounding air penetrate into the chamber. When the chamber was validated (Isaxon 2008), in the absence of test subjects and at air exchange rates of approximately 4/h, trace gas measurements showed that spatial concentration gradients are less than 15% throughout the chamber volume. In the presence of test subjects, the degree of mixing improves due to thermal convection induced by the test subjects.

The chamber is suited for human exposures as well as for source characterization (Pagels et al. 2009) and aerosol transformation studies.

The conditioning system was started well before the human exposures to ensure that the chamber was filled with fresh clean air at the start of the experiment. The air exchange rate of 5.8/h was necessary to keep the CO_2 level at comfortable values (not exceeding 1000 ppm) for human test subjects. The target chamber temperature was 23°C , since pilot tests with human volunteers showed that this was the temperature of highest comfort. The target RH was 25–30%, which was the range observed at the welding workplaces. Both the workplace measurements and the human exposure study took place during wintertime. Three human test subjects were in the chamber during each exposure event. The subjects were exposed while seated. The test subjects were visually monitored all the time by a medical doctor sitting outside the chamber by the window.

3. PARTICLE CHARACTERIZATION AND AIR MONITORING

During the exposures, $\text{PM}_{2.5}$ particle mass concentration in the chamber was monitored with a Tapered Element Oscillating Microbalance (TEOM, Rupprecht & Patashnic Co. Inc., Albany, NY, USA), calibrated by the manufacturer, at 50°C and with a cyclone as a precollector for particles larger than $2.5\ \mu\text{m}$. The particle number concentration and mobility size distribution (10–650 nm) were measured using a Scanning Mobility Particle Sizer (SMPS) system, calibrated by polystyrene latex spheres and a reference condensation particle counter, consisting of a long column Hauke type differential mobility analyzer (DMA), with an aerosol flow rate of 0.5 lpm and a sheath airflow rate of 5 lpm and a CPC 3010 (TSI, Shoreview, MN, USA).



FIG. 1. (above) The stainless steel chamber at the University of Lund. (below) The arrangement of test subjects (in this case female volunteers) inside the chamber.

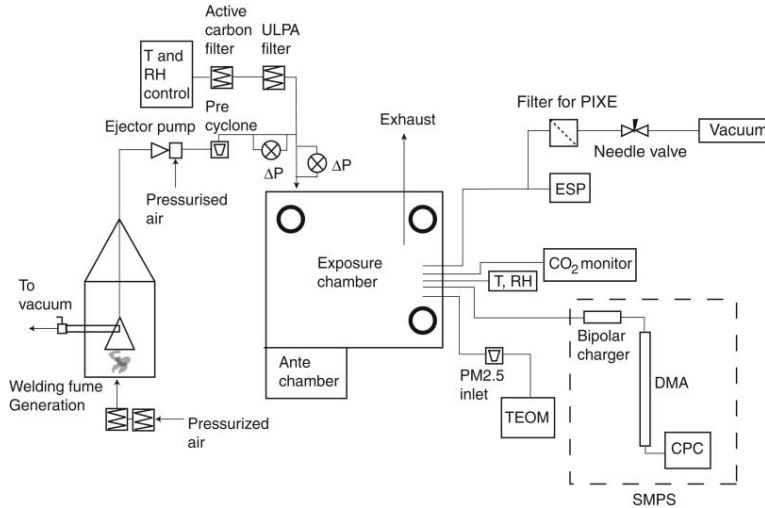

FIG. 2. Schematic view of the complete generation/exposure system. The rings show where the three test subjects are placed.

Diffusion driers were installed in the sheath flow loop. The welding aerosol chemical composition was characterized by PIXE and X-ray energy dispersive spectroscopy (XEDS). Using a stacked filter unit (SFU), samples for PIXE analysis were collected for 260 min on 54 mm capillary pore (Nuclepore) filters at 4 lpm, with a PM2.5 cut-off. The SFU consists of two capillary pore filters connected in series, as described by Heidam (1981). The pore size in the first filter is $8\ \mu\text{m}$ with high transmission of fine particles. The second filter has a pore size of $0.4\ \mu\text{m}$ ensuring an effective collection of the fine particles (Pagels et al. 2003). At PIXE analysis, a proton beam of 2.55 MeV is focused on the $0.4\ \mu\text{m}$ filter specimen, causing a vacancy in the inner shell of an atom, which put the atom in a state of high excitation. A transition to a state of lower energy quickly occurs, and a series of characteristic X-ray emission lines is obtained (Johansson 1989). The cross-section for the creation of an inner shell vacancy is very high using protons, and therefore the sensitivity is high—most elements except the very light ones ($Z < 14$) can be detected in concentrations below 1 ppb. Using an electrostatic precipitator, samples were collected for transmission electron microscopy (TEM) and XEDS onto carbon coated Cu TEM grids. The XEDS method detects characteristic X-rays, in ways similar to the PIXE method, with the difference that XEDS uses a high-energy electron beam to excite the atom. The detection limit of XEDS is around 1 atomic%, and the lightest detectable element is Be ($Z = 4$) (Messing 2011). Temperature, relative humidity (Swema Air 300, Swema, Stockholm, Sweden), and carbon dioxide levels (RI-411A, RKI Instruments, Union City, CA, USA) were monitored online in the chamber

during the human exposures. The complete exposure system including welding fume generation is shown in Figure 2.

4. RESULTS

Figure 3 illustrates how the number and mass concentrations in the chamber typically varied with time during an exposure event. The exposures started at 09:30 and finished at 16:00. The welding pulses resulted in rapid increases in particle concentration, which quickly declined, mostly due to the relatively high air exchange rate. It can be seen that the precision in peak mass and number concentration after each welding episode was within a factor of two, which illustrates a reasonable repeatability in the manual welding procedure. These concentration fluctuations are similar to what was noticed in the welding workshops.

The aim to generate a mean mass concentration realistic for a workday, $1000\ \mu\text{g}/\text{m}^3$, was achieved. The procedure proved to deliver reproducible results throughout the number of exposure events, as can be seen in Table 1, where the mean values are given with standard deviation showing the variations between the different exposure events. It was possible to vary the length of the pulses and their frequency so that a mean mass concentration of $1000 \pm 70\ \mu\text{g}/\text{m}^3$ could be maintained at every event. The number and mass concentrations as well as carbon dioxide, relative humidity, and temperature during the exposure events are shown in Table 1.

In Figure 4, number size distribution of generated welding fume in the chamber and measured in the workplace is presented. The size distribution of the generated welding fume is typically

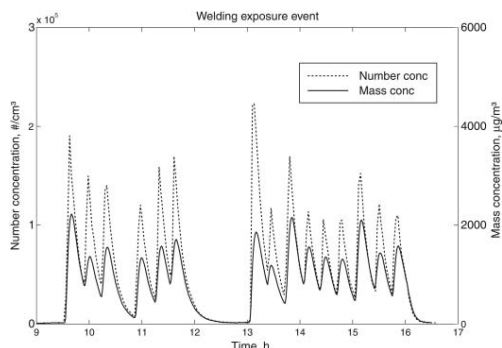

FIG. 3. Temporal variations of number and mass concentrations in the chamber during a typical welding exposure event. During human exposures, the test subjects had lunch between 12:00 and 13:00 and no activities took place in the exposure chamber at this time.

a single mode with a geometric mean diameter of 160 nm. This corresponds well to what was seen at the in-plume measurements in the welding workshops (measured in a MAG welding plume) (Figure 4) and with what others have observed (Zimmer and Biswas 2001). The workshop size distribution is narrower partly because it was sampled closer to the welding point.

The geometric mean diameter did not vary by more than ± 10 nm in-between exposure events.

Figure 5 shows the chemical composition of the generated welding fume compared to that measured in the plume in a welding workshop when MAG welding in mild steel was being conducted.

The major metal in the generated welding fume is iron. A fume fraction of 1/5 of manganese was seen in both the workshop measurements and during exposure events, and considerably larger in the fume than in the welding electrode (1.5% Mn in the Aristorod 12.50 used in the laboratory). This was likely due to the higher volatility of manganese compared to iron. In contact with the surrounding air, both iron and manganese form oxides. One can expect to find manganese in the oxidation

TABLE 1
Mean levels during the 13 welding exposure events

	Mean exposure	SDOM
Number concentration ($/\text{cm}^3$)	64,300	15,000
PM2.5 mass concentration ($\mu\text{g}/\text{m}^3$)	1000	70
CO ₂ (ppm)	670	134
RH (%)	26.9	1.7
T (°C)	23.3	1.0

SDOM = standard deviation of means (shows the variation between the different exposure events).

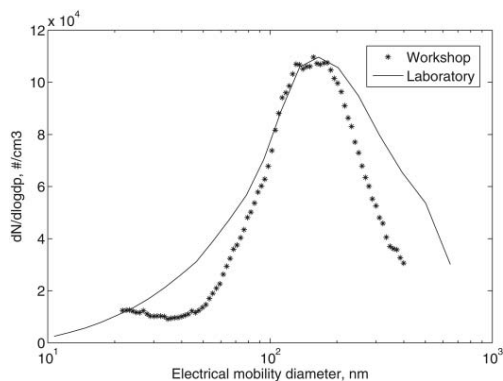

FIG. 4. MAG welding number distributions from laboratory and workshops. Workshop data have been normalized to fit the maximum value of the chamber number concentration. The number concentration is given as $dN/d\log D_p$, indicating that the concentration in each size bin of the instrument has been normalized to the width of the bin.

states Mn^{2+} and Mn^{3+} and ferrous oxides such as FeO , Fe_2O_3 , and Fe_3O_4 in the welding fume. The compounds among "other species" in the generated fume are summarized in Table 2.

Compounds with concentrations below the PIXE detection limit were arsenic, bromine, chromium, nickel, phosphorus, rubidium, selenium, strontium, titanium, vanadium, and yttrium.

TEM images showed aggregates of varying size, composed of a few to several hundred primary particles (Figure 6). The primary particle size was in the size range between 2 and 70 nm, depending on where along the temperature gradient from welding point to surrounding air they had been formed.

Figure 7 shows an example of the results from XEDS. In this specific image, three primary particles of different size were analyzed and found to be composed of similar proportions of oxygen, manganese, and iron.

The results of the particle characterizations also show that, despite the fact that the majority of the emitted particles are larger than 100 nm (Figure 4), welding particles are agglomerates consisting of nanosize primary particles (Figures 6 and 7).

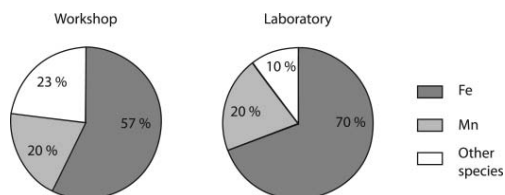

FIG. 5. The elemental composition in mass% measured with PIXE (elements heavier than aluminum) of welding smoke as measured in the welding workshop and during the exposure studies.

TABLE 2
Amount of species, detectable with PIXE, other than iron and manganese in the generated welding fume

Specie	Si	Cu	Zn	Cl	Pb	S	Ca	K	Co
% Mass	4.5	1.4	1.4	0.9	0.9	0.3	0.2	0.2	0.1

5. SUMMARY AND DISCUSSION

A method to perform detailed characterization and human exposure studies of nanosized and nanostructured welding fume has been developed and validated. The laboratory generated welding fumes were similar in composition and particle size distribution to the fumes measured in welding workshops. The generation method was reproducible at all exposure events throughout the duration of the study. The aimed target exposure mean concentration was obtained in each exposure event, ensuring that test subjects would be exposed to a manganese level well below the 8 h health limit value of $100 \mu\text{g}/\text{m}^3$.

The real-time instrumentation used for chamber air monitoring can give a clear overview of what the test subjects were exposed to at any given time. The SMPS system, which uses a DMA to sort particles into size bins based on their mobility in an electric field, was used primarily because there was a need for online number concentration and size distribution measurements during the human exposures. Welding fume particles are aggregated, however, sizing of particles according to their mobility diameter is expected to describe the deposition probability in the respiratory tract for the size fraction $<0.5 \mu\text{m}$, where diffusion is the dominating deposition mechanism (Rissler et al. 2012), which proposes an additional argument for using SMPS in human exposure studies. The SMPS data from the human exposures could, together with information of shape and primary particle size from TEM analysis and particle density, later on be used for calculating parameters other than mobility equivalent size distribution and number concentration if needed. For example, calculation of surface area of the agglomerates/aggregates as a function of mobility diameter can be done if additional characterization with an aerosol particle mass analyzer (APM) is done (as suggested by Rissler et al. 2012). The SMPS is fre-

quently used in emission and exposure studies and, hence, the data from this system are valuable for comparison of results.

It is instructive to compare the mass concentration from the TEOM with the effective volume concentration from the SMPS (using the mobility size as diameter measure). From this the apparent density was found to be $1 \text{ g}/\text{cm}^3$ for the welding aggregates, which is about half an order of magnitude lower than that of the bulk density of the expected iron oxides ($5\text{--}6 \text{ g}/\text{cm}^3$) present in the welding fume particles. Thus, a density much lower than the bulk density must be used if estimating the mass concentration from SMPS measurements of welding fumes. A similar argument holds when calculating aerodynamic diameters of the welding fume aggregates, as a density much lower than the bulk density of the material needs to be used. This effect could be seen in the workplace measurements where the mass median aerodynamic diameter (200 nm) was only marginally larger than the count median diameter of the SMPS (160 nm). The small aerodynamic diameter of the agglomerates also may have important implications for the respiratory tract deposition due to sedimentation of such larger particles.

Detailed characterization of welding fume particles in this study showed that the majority of emitted particles are larger than 100 nm but are agglomerates of primary nanosize particles. These, upon contact with airway tissue, may disintegrate into numerous metal-containing particles (Bohgard et al. 1979). This suggests that particles from thermal processes in industrial workplaces could be used as reference or model particles in studies assessing potential health effects of nanosized particles from emerging applications of nanotechnology. The aim of this study was to examine the nanostructure of welding fume which have similarities (in generation mechanism—arc discharge, in structure/morphology, in size) with a variety of engineered

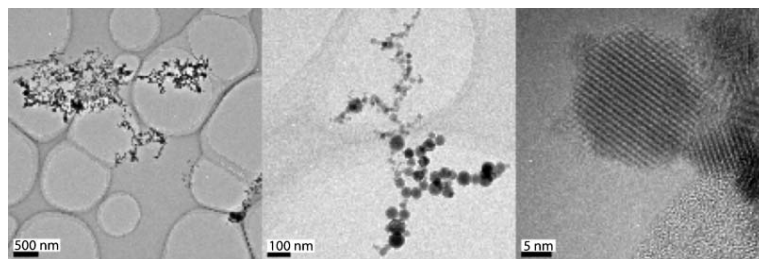

FIG. 6. Welding fume aggregates in three different magnifications.

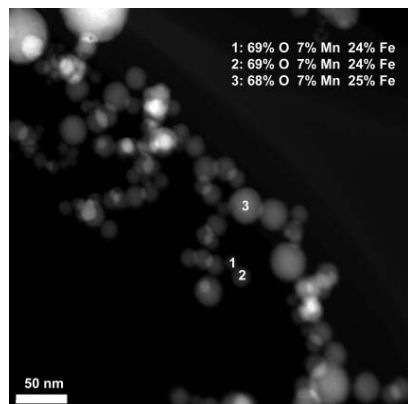

FIG. 7. XEDS analysis of welding fume particles, showing the atomic percent of oxygen, manganese, and iron in three primary particles of different size.

nanoparticles. A large population of welders has been, and is being, exposed to these types of particles. Occupational exposure to engineered nanoparticles is expected to increase. The developed methodology can be used for studying the health effects of nanostructured particles from welding. This will also increase our understanding on how nanoparticles affect humans.

Human exposure studies can serve to bridge the gap between epidemiology and toxicology, and help in extrapolating the results from animal studies to the human system. The developed methodology described in this article is safe and efficient enough to be used for future human exposure studies. In the future, human exposure studies based on this protocol in principle can be carried out for engineered nanoparticles, such as carbon nanotubes, as well as other indoor sources. The generation chamber and the aerosol transport/dilution system into the exposure chamber are suitable for combustion-generated aerosols in general (e.g., candle smoke). When using the exposure chamber and monitoring/characterization instruments for other aerosols, the generation part of the system may need to be modified depending on type of aerosol and generation method.

REFERENCES

- Antonini, J. M., Afshari, A. A., Stone, S., Chen, B., Schwegler-Berry, D., Fletcher, W. G., et al. (2006). Design, Construction and Characterization of a Novel Robotic Welding Fume Generator and Inhalation Exposure System for Laboratory Animals. *J. Occup. Environ. Hyg.*, 3(4):194–203.
- Bohgard, M., Jangida, B. L., and Akesson, R. (1979). An Analytical Procedure for Determining Chromium in Samples of Airborne Dust. *Ann. Occup. Hyg.*, 22:241–251.
- Brook, R. D., and Rajagopalan, S. (2010). Particulate Matter Air Pollution and Atherosclerosis. *Curr. Atheroscler. Rep.*, 12(5):291–300.
- Brown, D. M., Stone, V., Findlay, P., MacNee, W., and Donaldson, K. (2000). Increased Inflammation and Intracellular Calcium Caused by Ultrafine Carbon Black is Independent of Transition Metals or Other Soluble Components. *Occup. Environ. Med.*, 57:685–691.
- Crossgrove, J., and Zheng, W. (2004). Manganese Toxicity upon Overexposure. *NMR Biomed.*, 17:544–553.
- Donaldson, K., Li, X. Y., and MacNee, W. (1998). Ultrafine (Nanometre) Particle Mediated Lung Injury. *J. Aerosol. Sci.*, 29:553–560.
- Gil, P. R., Oberdorster, G., Elder, A., Puentes, V., and Parak, W. J. (2010). Correlating Physico-Chemical with Toxicological Properties of Nanoparticles: The Present and the Future. *ACS Nano.*, 4(10):5527–5531.
- Heidam, N. C. (1981). Review: Aerosol Fractionation by Sequential Filtration with Nuclepore Filters. *Atmos. Environ.*, 15(6):891–904.
- Isaxon, C. (2008). Controlled Human Exposures to Aerosol Particles. MSc thesis ISRN LUTMDN/TMAT-5118-SE, Lund University, Lund, Sweden.
- Isaxon, C., Pagels, J., Gudmundsson, A., Asbach, C., John, A. C., Kuhlbusch, T. A. J., et al. (2009). Characteristics of Welding Fume Aerosol Investigated in Three Swedish Workshops, Conference Proceeding for Inhaled Particles X. *J. Phys. Conf. Ser.*, 151(1).
- Jenkins, N. T. (2003). Chemistry of Airborne Particles from Metallurgical Processing. Doctoral thesis, Massachusetts Institute of Technology, Cambridge, MA.
- Johansson, S. A. E. (1989). PIXE: A Novel Technique for Elemental Analysis. *Endeavour, New series*, 13(2):48–53.
- Kreyling, W. G., Semmler, M., Erbe, F., Mayer, P., Takenaka, S., Schulz, H., et al. (2002). Translocation of Ultrafine Insoluble Iridium Particles from Lung Epithelium to Extrapulmonary Organs is Size Dependent but Very Low. *J. Toxicol. Environ. Health Part A*, 65:1513–1530.
- Li, N., Sioutas, C., Cho, A., Schmitz, D., Misra, C., Sempf, J., et al. (2003). Ultrafine Particulate Pollutants Induce Oxidative Stress and Mitochondrial Damage. *Environ. Health Perspect.*, 111:455–460.
- Messing, M. (2011). Engineered Nanoparticles Generation, Characterization and Applications. Doctoral thesis, Lund University, Lund, Sweden.
- Oberdorster, G., Sharp, Z., Atudorei, V., Elder, A., Gelein, R., Kreyling, W., et al. (2004). Translocation of Inhaled Ultrafine Particles to the Brain. *Inhal. Toxicol.*, 16:437–445.
- Oberdorster, G., Sharp, Z., Atudorei, V., Elder, A., Gelein, R., Lunts, A., et al. (2011). Extrapulmonary Translocation of Ultrafine Carbon Particles Following Whole-Body Inhalation Exposure of Rats. *J. Toxicol. Environ. Health Part A*, 65:1531–1543.
- Pagels, J., Strand, M., Rissler, J., Szpila, A., Gudmundsson, A., Bohgard, M., et al. (2003). Characteristics of Aerosol Particles Formed during Grate Combustion of Moist Forest Residue. *J. Aerosol. Sci.*, 34:1043–1059.
- Pekkanen, J., Peters, A., Hoek, G., Tiittanen, P., Brunekreef, B., de Hartog, J., et al. (2002). Particulate Air Pollution and Risk of ST-Segment Depression during Repeated Submaximal Exercise Tests among Subjects with Coronary Heart Disease - The Exposure and Risk Assessment for Fine and Ultrafine Particles in Ambient Air (ULTRA) Study. *Circulation*, 106:933–938.
- Pope, C. A., Burnett, R. T., Thun, M. J., Calle, E. E., Krewski, D., Ito, K., et al. (2002). Lung Cancer, Cardiopulmonary Mortality, and Long-Term Exposure to Fine Particulate Air Pollution. *J. Am. Med. Assoc.*, 287:1132–1141.
- Quimby, B. J., and Ulrich, G. D. (1999). Fume Formation Rates in Gas Metal Arc Welding. *Weld. J.*, 78(4):142–149.
- Redding, C. J. (2002). Fume Model for Gas Metal Arc Welding. *Weld. J.*, June, 95–103.
- Rissler, J., Swietlicki, E., Bengtsson, A., Boman, C., Pagels, J., Sandström, T., et al. (2012). Experimental Determination of Deposition of Diesel Exhaust Particles in the Human Respiratory Tract. *J. Aerosol. Sci.*, 48:18–33.
- Tabrizi, N. S., Xu, Q., van der Pers, N. M., and Schmidt-Ott, A. (2010). Generation of Mixed Metallic Nanoparticles from Immiscible Metals by Spark Discharge. *J. Nanopart. Res.*, 12(1):247–259.
- Trout, D. B., and Schulte, P. A. (2010). Medical Surveillance, Exposure Registries, and Epidemiologic Research for Workers Exposed to Nanomaterials. *Toxicology*, 269:128–135.
- Warheit, D. B., Borm, P. J. A., Hennes, C., and Lademann, J. (2007). Testing Strategies to Establish the Safety of Nanomaterials: Conclusions of an ECETOC Workshop. *Inhal. Toxicol.*, 19:631–643.
- Zimmer, A. T., and Biswas, P. (2001). Characterization of the Aerosols Resulting from Arc Welding Processes. *J. Aerosol. Sci.*, 32:993–1008.

Article III

Contribution of indoor-generated particles to residential exposure

Isaxon C¹., Gudmundsson A¹., Nordin E.Z¹., Lönnblad L²., Dahl A., Wieslander G³., Bohgard M¹., Wierzbicka A¹.

¹ Ergonomics and Aerosol Technology, Lund University, Sweden,

² Astronomy and Theoretical Physics, Lund University, Sweden,

³ Occupational and Environmental Medicine, Uppsala University, Uppsala, Sweden

*Corresponding author: christina.isaxon@design.lth.se

Abstract

In residences the majority of airborne particles, when expressed as number concentrations, are generated by the residents, mainly by combustion/thermal related activities, and are considerably smaller than 2.5 µm. For several reasons, these particles may cause adverse health effects, likely due to the combination of their small size, their chemical composition (e.g. soot) and their intermittently very high concentrations.

In this study, time resolved stationary air measurements were conducted for seven consecutive days in 39 randomly selected homes in the urban area of Lund in southern Sweden. The main purpose of this research was to analyze the influence of human activities on the concentration of fine and ultrafine particles in indoor air. Focus was on number concentrations of particles < 300 nm generated by indoor activities, and how these contribute to the integrated daily residential exposure. Correlations between these particles and soot mass concentration in total dust were also investigated.

It was found that candle burning and activities related to cooking (using a frying pan, oven, microwave oven, toaster, and their combinations) were the major particle sources.

The frequency of occurrence of a given concentration indoors and outdoors were compared for particles < 300 nm. Indoor data was sorted into non-occupancy and occupancy time, and the occupancy time was further divided into non-activity and activity time. It was found that high levels (above 10⁴ cm⁻³) indoors mainly occur during active periods of occupancy, while the concentration during non-activity time differs very little from non-occupancy time.

Total integrated daily exposure of particles < 300 nm was calculated for 22 homes, and was on average 4.0·10⁵ ± 3.5·10⁵ cm⁻³·h/d. Of this, the contribution from known activities was 2.7·10⁵ ± 2.6·10⁵ cm⁻³·h/d (66 %), from unknown activities 1.1·10⁵ ± 1.9·10⁵ cm⁻³·h/d (20 %), and from background/non-activity 3.6·10⁴ ± 1.9·10⁴ cm⁻³·h/d (14 %).

The collected data also allowed for estimates of particle source strengths for some specific activities, and for some activities it was possible to estimate correlations between the number concentration of particles smaller than 300 nm and the mass concentration of soot in total dust in 10 homes.

Particle source strengths were estimated for 7 specific activities, and ranged from 1.6·10¹² to 4.5·10¹² min⁻¹.

The correlation between particles <300 nm and mass concentration of soot in total dust in the 10 homes varied between 37 and 85 %, with an average of 56 %.

This study clearly shows that due to the importance of indoor sources, residential exposure to particles smaller than 300 nm cannot be characterized by ambient measurements alone.

Introduction

The main aims of this study were to analyze the influence of human activities on fine and ultrafine particles in indoor air, with focus on determining the differences between residential and outdoor number concentrations of particles smaller than 300 nm; to estimate contribution of indoor sources to integrated daily residential exposure; and to check correlation between mass concentration of soot in total dust and number concentration of particles smaller than 300 nm in residences in general as well as during different activities.

In the industrialized part of the world, we spend approximately 65 % of our lives in our homes (Brasche and Bischof, 2005; Leech et al., 2002). Hereby we are subjected to various indoor-generated airborne particles as well as the background particles originating from outdoors. It is widely known that outdoor particles contribute to the indoor aerosol concentration levels, and in epidemiology exposure is often determined based on the outdoor particle concentration. However the outdoor contribution to the indoor aerosol size distribution is modified compared to the distribution outdoors, due to size-specific differences in penetration efficiency (Thatcher et al., 2003; Liu and Nazaroff, 2003; Nazaroff, 2004). Accumulation mode particles have the highest penetration (Nazaroff, 2004) since these particles have a rather low diffusivity and are too small to be significantly affected by sedimentation or impaction. But to a far greater extent than outdoor generated particles, the particle concentration and size distribution in homes are dominated by aerosols generated by the residents' activities. For naturally ventilated buildings, Morawska and Salthammer (2003) found indoor/outdoor ratios (I/O) for PM₁₀ and PM_{2.5} (particulate matter smaller than 10 µm and 2.5 µm, respectively) from 0.5 to 0.98 and 0.54 to 1.08, respectively, in the absence of indoor sources. However, when indoor sources were present, I/O ratios for PM₁₀ and PM_{2.5} ranged from 1.14 to 3.91 and 1 to 2.4, respectively, which stress the significance of indoor source contributions (Morawska et al., 2013).

It has been shown (Hussein et al., 2006; Wallace et al., 2006; Turpin et al., 2007; Wierzbicka, 2008) that the major sources contributing to indoor air concentrations are combustion related or related to thermal processes (e.g. cooking, smoking and candle burning). Peak number concentrations from cooking have been found to be higher than reported outdoor peak concentrations (Dennekamp et al., 2001; He et al., 2004; Wan et al., 2011), by an order of magnitude and sometimes more. It is well known that combustion generated particles generally are considerably smaller than 2.5 µm, often smaller than 300 nm (Géhin et al., 2008), which justifies that number the concentration of ultrafine particles would be a more relevant metric to capture/determine residential exposure to combustion-related particles. Ultrafine particles are of special interest from a health perspective, since they, due to their small aerodynamic diameter, can penetrate deeper into the respiratory system and cause inflammatory effects. The ultrafine particles also have a higher deposition rate, which in itself can cause adverse effects (Hirano et al., 2009; Araujo et al., 2008, Oberdörster et al., 2005). Studies (Wang et al., 2009; Kennedy, 2007; WHO 2005) have shown that the number concentration of ultrafine particles induce more adverse health effects than the mass concentrations of PM₁₀ and PM_{2.5} (to which the ultrafine particles are a poor contributor).

Soot (elemental carbon), which can infiltrate the building from outdoors, is a primary component in several emissions known to affect human health indoors, such as wood burning, cigarette smoke, cooking with poor ventilation but also e.g. diesel exhaust. Soot particles often contain elements such as polycyclic aromatic hydrocarbons (PAH), but are of health interest also due to their small size and because of their active surface which attracts gases and other particle phase toxins. Since the major sources of ultrafine particles indoors have been shown to be combustion/thermal related, it is likely that soot is a major component of this aerosol and it is therefore of interest to monitor the soot

concentration indoors. Monitoring soot concentrations in parallel to fine and ultrafine particle number concentrations could also give an indication of how much combustion contribute to the concentration of ultrafine particles.

Methods

For seven consecutive day, time resolved stationary air measurements were conducted in randomly selected homes (N=39) in the urban area of Lund in southern Sweden. The measurements were conducted during wintertime. Number concentrations, and mean diameter, of particles <300nm were monitored with Mini Diffusion Size Classifier (DiSC) (University of Applied Sciences, Windisch, CH) or Nanotracer (Philips Aerasense). These instruments are based on an electrical measurement technique, with a diffusion charger followed by electrometers that measure the current carried by charged particles. Since a majority of particles generated by indoor activities are smaller than 300 nm, results from the Nanotracer and DiSC can be considered as good approximations of ultrafine particles. The accuracy of both the Nanotracer and DiSC are $\pm 30\%$ (Asbach et al., 2012).

The measurements of particles larger than 0.3 μm were performed by an optical particle counter, Indoor Air Quality monitor (IAQ3016, Lighthouse). Particles passing a laser beam inside the instrument scatter light. The scattered light is detected by a photo detector, which converts the light to an electrical pulse. For a single particle, the height of the generated pulse depends on the size, refractive index and color of the particle. According to a reference aerosol of monodisperse PSL particles, the pulse height is transferred to six particle size intervals. The pulse height thresholds in the IAQ3016 correspond to particle sizes of 0.3, 0.5, 1.0, 2.5, 5.0 and 10 μm . Black carbon (soot) levels were monitored by microAeth (AE51, Magee Scientific) in 10 of the homes, to investigate the correlation between soot measurements and indoor (particularly combustion related) activities. The soot monitor measures the transmission of infrared (IR) light (880 nm) through a filter, which is continuously loaded with airborne particles by the suction of an internal pump. The accumulation of particles on the filter over time increases the absorbance, which is calculated relative to a reference cell. The attenuation IR is then transferred to mass concentration of black carbon (described in detail by Cheng and Lin (2013)). Temperature and relative humidity were logged (USB-500, Measurement Computing). All measurements were made during off-pollen season (October-April). The instruments were zero-calibrated before each home, and placed between 1 and 1.5 m above the floor centrally in the dwelling, but not in, or in direct connection to, the kitchen, on a shelf as shown in Figure 1. The shelf was constructed for occupying a minimum amount of space so that the instruments could be placed at a central spot and yet not be in the way of daily living.



Figure 1. Instrument set-up.

CO₂ data was collected in one bedroom in each residence. CO₂ concentration was measured with CARBOCAP CO₂ monitors (GMW22, Vaisala, Finland) connected to a HOBOU12-012 data loggers (Onset Computer Corp., USA) to record the measured values. CO₂ levels were used for estimation of air exchange rates on the basis of occupant-generated CO₂ mass balance method as described by Bekö et al. (2010). The method is based on analyzing steady state concentrations or buildups and decays of CO₂ in bed rooms.

The inhabitants filled in detailed activity log books, and made notes of when they were present or absent in the dwelling.

A thorough examination of each home – e.g. construction year, floor and wall materials, and ventilation system – was conducted according to a structured protocol. In addition, the participants filled in a translated and modified version of the IUATLD (International Union Against Tuberculosis and Lung Disease) questionnaire (Burney and Chinn, 1987; Burney et al., 1989) covering both the characteristics of the dwelling and the residents and their everyday habits. The results of these examinations will be presented elsewhere.

Ambient (outdoor) number concentrations were monitored constantly by a scanning mobility particle sizer (SMPS, consisting of a TSI 3071 Differential Mobility Analyzer, DMA and a TSI 3010 Condensation Particle Counter, CPC) from a station in northern Lund. The station was located within a radius of 5 km from the majority of the homes.

Data processing

Three of the 39 residences were student dormitories, which were not considered representative of common home settings and will be presented elsewhere. In this article, measurements from 22 homes, where Nanotracer or DiSC collected data without reporting any problems, were analyzed.

A classification of the number concentration measurements (<300 nm) was carried out by sorting the data into two categories: occupancy time (at least one person present in the home) and non-occupancy time. The decay of a peak caused by an activity during occupancy time had a negligible effect on concentrations during non-occupancy time.

From the particle number concentration data, the integrated exposure was calculated by integrating the concentration over time (particles/cm³·h). The total integrated daily exposure was calculated by dividing the integrated exposure by the measurement period (in days) resulting in units of particles per cm³·h/day. The total daily integrated exposure was calculated for periods of activities and periods of non-activities. The known and unknown activities are identified as apparent concentration elevations from baseline concentration, which could, respectively could not, be identified by the residents' notes in the activity logs. The activity period was defined as starting at the time when concentrations started to increase and end at the time when concentrations had returned to baseline, thus it does not represent the duration of given activity but rather elevated concentrations being the effect of it. During non-activity, it was assumed that the particles indoors originate mainly from outdoor sources.

Due to that the Indoor Air Quality monitor reported flow problems in several cases, data from only 9 homes (of which 7 matched the abovementioned 22 homes), where the instrument ran without complications for the whole measurement duration, could be evaluated. This data was sorted into occupancy time and non-occupancy time and transferred to particle mass concentration using the density of carbon (2500 kg/m³), which is recommended by the manufacturer as a suitable density for arbitrary ambient particles. The six channels were then compressed to PM_{1-0.3} and PM₁₀₋₁, since these fractions match the accumulation mode and the coarse mode fairly well (Lundgren and Burton, 1995; Morawska et al., 2008).

In 10 of the 22 houses mentioned above, soot data from microAeth was analyzed. When the sampling time is short and/or the soot concentration is low, noise from the instrument can cause attenuation values to be unchanged or even decline, from one period to the next. This may result in an erroneously low value at one time followed by an erroneously high value at the next (Cheng and Lin, 2013). Noise obstructs the actual variations in soot concentrations and makes comparison of the two datasets impossible.

A noise-reduction averaging (ONA) algorithm developed by Hagler et al. (2011) and evaluated by Cheng and Lin (2013) was used to eliminate the negative values and reduce the noise, while maintaining high time resolution.

Results and discussion

Ultrafine particles and residents' activities

The data analysis was focused on the results from the ultrafine particle measurements by the Nanotracer and DiSCmini. In Table 1, the characteristics of the homes, in which data from these measurements were used, are summarized. In some cases the bedroom design was such that no obvious build-up occurred (e.g. no door, open window, bed placed in living room), and in a few cases

it was not possible to estimate the bedroom volume (open space apartment). In total, it was possible to estimate air exchange rates in 15 homes.

Table 1. Homes in which full-time measurements with Nanotracer or DiSC were conducted without reported instrument problems, and activity logs were considered readable and reliable.

Home	Type of home	Measurement duration [days]	AER [h^{-1}]	Ventilation type	Volume [m^3]	Temp ($^{\circ}\text{C}$) mean (std)	RH (%) mean (std)
02	House	6.12	0.4	a	293	22.0 (0.4)	47 (3)
03	House	6.10	0.7	c	350	22.0 (0.4)	47 (3)
04	Apartment	7.26	0.4	d	250	23.6 (0.6)	35 (3)
05	House	6.95	N/A	a		22.4 (0.4)	47 (3)
07	Apartment	2.42	1.6	b	168	21.9 (1.5)	37 (3)
08	Apartment	7.14	1.5	a	96	21.8 (0.9)	38 (4)
10	Apartment	6.59	1.4	c	227	23.4 (0.6)	36 (4)
15	House	6.50	2.3	c	327	23.5 (0.5)	37 (2)
16	Apartment	6.30	1.0	b	202	22.9 (0.3)	34 (4)
17	Apartment	6.64	2.9	a		N/A	N/A
18	Apartment	6.82	1.1	d	118	20.7 (0.4)	43 (4)
19	House	6.61	1.0	c	288	22.8 (0.7)	35 (2)
20	House	6.55	1.0	N/A		22.3 (0.6)	43 (2)
21	Apartment	7.10	0.3	a	195	22.3 (0.4)	38 (3)
23	Apartment	5.69	0.4	b	132	N/A	N/A
24	Apartment	8.95	1.4	a	208	23.4 (1.4)	25 (2)
28	House	6.33	N/A	a	442	23.3 (0.9)	26 (2)
29	House	6.25	N/A	c		22.3 (1.0)	26(2)
32	Apartment,	6.92	N/A	a		25.2 (1.6)	28 (5)
33	Apartment	7.01	N/A	c		23.0 (1.3)	30(5)
34	House	7.00	N/A	a	328	21.8 (1.3)	35 (4)
38	House	6.62	N/A	N/A		N/A	N/A

- a) Additional exhaust mechanical ventilation in kitchen only (kitchen exhaust hood)
- b) Additional exhaust mechanical ventilation in kitchen and bathroom(s)
- c) Mechanical exhaust air in kitchen and bathroom(s) and fresh air supply valve ventilation in other rooms
- d) Natural ventilation

Occupancy time, in homes where full-time measurements with Nanotracer or DiSC were conducted without reported instrument problems, occurred during an average of 77 % of the measurement period. The geometric mean of the concentration of particles (<300 nm) during occupancy time was 4500, ranging from 1200 to 17000) cm^{-3} , and during non-occupancy time 2400 [1200, 4800] cm^{-3} . The origins of elevated concentrations were identified using the activity logs from the 22 homes in Table 1. Times with elevated concentrations (above background) due to activities occurred on average 33 % of the occupancy time.

Several of the concentration peaks were results of a combination of two or more particle generating activities. 13 different single activities, shown in Figure 2, could however be identified as contributing significantly to the indoor air particle concentration.

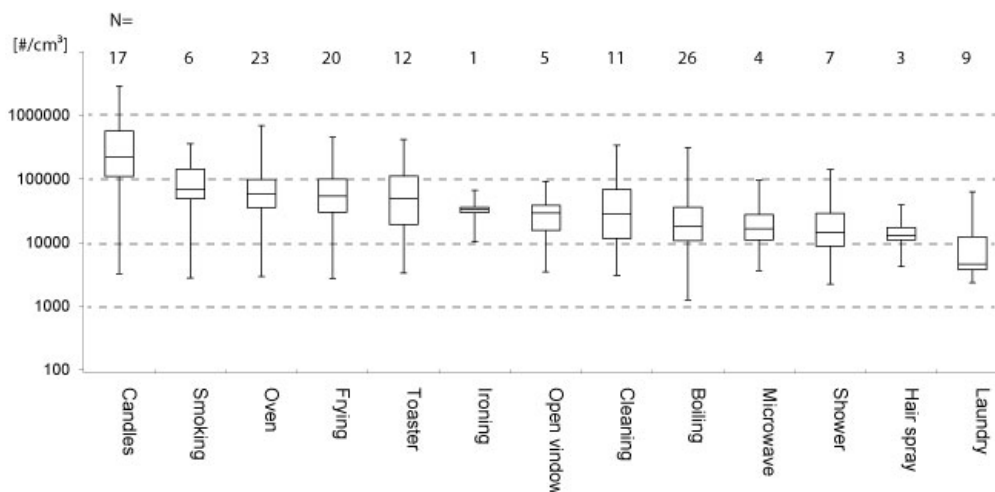

Figure 2. Summary of particle (<300 nm) number concentrations from various indoor activities in 22 residences. Box plots denote minimum values, 1st quartile, median, 3rd quartile and maximum values. N is the number of identified events the calculations are based on.

Candle burning and activities related to cooking (using a frying pan, oven, microwave oven, toaster, and their combinations) were the major particle sources. The elevated concentrations of ultrafine particles when cleaning are likely to be originating from the motor of the vacuum cleaner (Lioy et al., 1999; Afshari et al., 2005). Increased indoor concentration due to opening a window cannot be considered as an indoor source, but is in this case classified as an indoor activity.

The contribution of ultrafine particles due to activities was further studied by comparing the activity time data to the outdoor (ambient) concentrations of particles < 300 nm as given by the SMPS measurements. Data was sorted into concentration bins and the frequency of a given concentration was studied. Due to different time resolutions of the Nanotracer/DiSC and the SMPS, the measurement data was unit normalized (divided by the length of the measurement vector) which resulted in the normalized frequency of a given concentration to occur (y-axis) as a function of concentrations (x-axis). From Figure 3a and b it is obvious that levels of 10^4 cm^{-3} indoors almost only occur during human presence, which illustrates the huge influence residents have on the air at home. Based on the activity logs, occupancy periods can be divided into activity and non-activity time. Non-activity time was defined as the time when the particle concentration was not under influence of a defined activity. When number concentration data is plotted separately for non-activity and activity time (Figure 4a and b) the impact of the residents' activities on number concentration of ultrafine particles becomes even more apparent. The indoor air particle concentration during non-activity time differs very little from non-occupancy time.

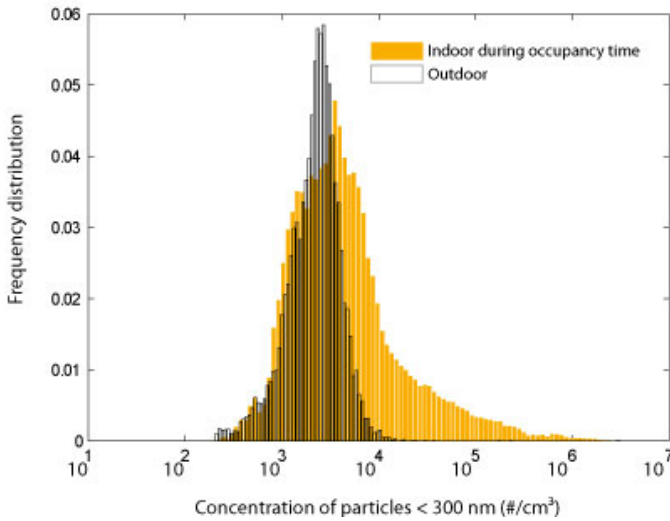
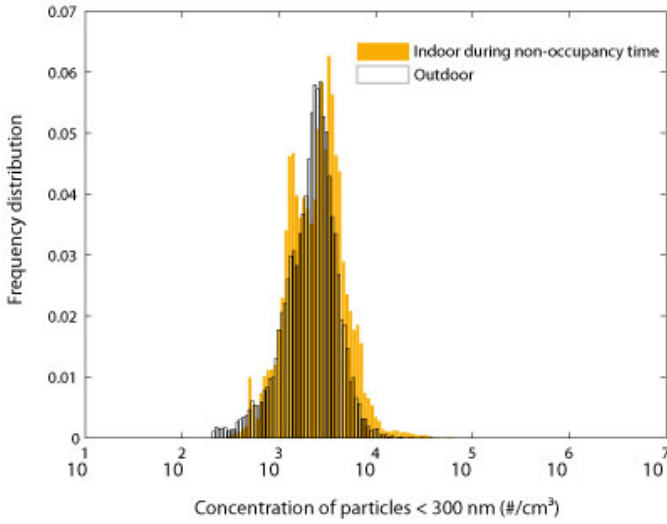

Figure 3a and b. Occurrence of particle (<300 nm) number concentrations outdoor (transparent) and indoors (orange) when no one is present in the residences (a) and when at least one person is present (b). Measurement data are unit normalized.

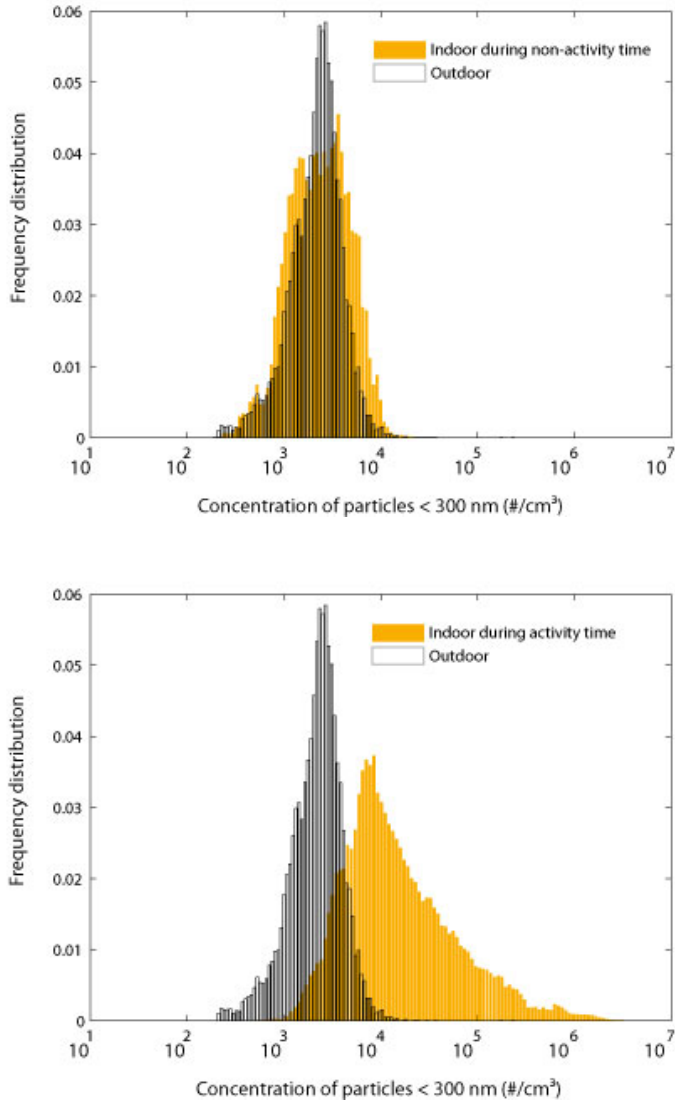

Figure 4a and b. Occurrence of particle (<300 nm) number concentrations outdoor (transparent) and indoors (orange) during non-activity time and activity time (i.e. times with elevated concentrations including decay of peaks after the activity ceased). Measurement data are unit normalized.

Source strengths, S , of particles <300 nm were estimated (Table 2) for 7 of the 13 activities in Figure 2, using a method described by Wallace and Ott (2011):

$$S = \frac{C_{max} V}{t}$$

Where S is the source strength or emission rate (particles/min), C_{\max} is the maximum concentration (cm^{-3}), V is the mixing volume (cm^3) and t is the time (min) during which a source is on.

The particle source strengths ranged from $1.6 \cdot 10^{12}$ to $4.5 \cdot 10^{12} \text{ min}^{-1}$.

Table 2. Source strengths, S , for 7 activities.

Activity	Number of peaks	Peak concentration [$\#/\text{cm}^3$] (std)	S , [$\#/\text{min}$] (std)
Boiling	11	$5.6 \cdot 10^4$ ($3.5 \cdot 10^4$)	$1.7 \cdot 10^{12}$ ($1.4 \cdot 10^{12}$)
Frying	8	$1.4 \cdot 10^4$ ($1.3 \cdot 10^4$)	$1.6 \cdot 10^{12}$ ($1.7 \cdot 10^{12}$)
Oven	10	$2.3 \cdot 10^5$ ($1.2 \cdot 10^5$)	$2.4 \cdot 10^{12}$ ($2.6 \cdot 10^{12}$)
Hairspray	3	$2.4 \cdot 10^4$ ($1.3 \cdot 10^4$)	$3.1 \cdot 10^{12}$ ($1.4 \cdot 10^{12}$)
Cleaning	3	$2.8 \cdot 10^5$ ($9.3 \cdot 10^4$)	$2.4 \cdot 10^{12}$ ($1.7 \cdot 10^{12}$)
Laundry	1	$2.5 \cdot 10^4$	$4.5 \cdot 10^{12}$
Toaster	3	$1.6 \cdot 10^5$ ($1.2 \cdot 10^5$)	$1.9 \cdot 10^{12}$ ($1.3 \cdot 10^{11}$)

Particle mass concentration

The results of the measurements using the Indoor Air Quality monitor for estimation of the particle mass concentration together with the particle number concentrations measured with Nanotracer or DiSCmini devices are shown in Figure 5. Median PM_{10-1} (corresponding to coarse mode) mass concentration was 17.9 [4.8, 49.9] $\mu\text{g}/\text{m}^3$ during occupancy time and 3.3 [2.0, 9.2] $\mu\text{g}/\text{m}^3$ during non-occupancy time. The median $\text{PM}_{1-0.3}$ (accumulation mode) mass concentration showed less differences: 8.0 [4.3, 14.3] $\mu\text{g}/\text{m}^3$ during occupancy time and 5.2 [2.9, 9.0] $\mu\text{g}/\text{m}^3$ during non-occupancy time.

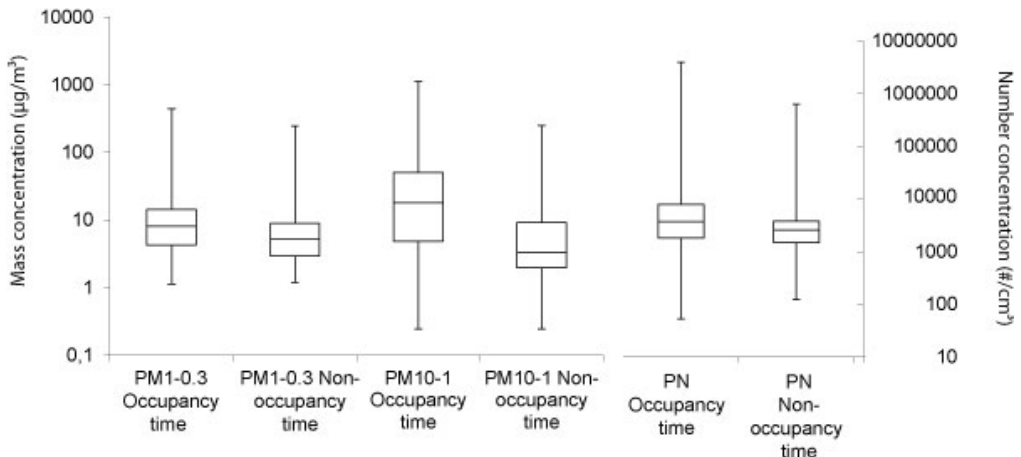

Figure 5. Boxplots of particle mass concentrations ($\text{PM}_{1-0.3}$ and PM_{10-1}) (left) and particle < 300 nm number concentration (right) during occupancy and non-occupancy time. The boxes denote the quartiles, the horizontal line the medians and the whiskers maximum and minimum concentrations.

Generally concentrations during occupancy time for both coarse mode and < 300 nm were higher in comparison to non-occupancy time. Higher concentrations of coarse mode during occupancy time may

reflect resuspension of settled dust indoors, while higher number concentrations of particles < 300 nm reflect the (mainly combustion related) activities of the residents.

Integrated daily residential exposure

Figure 6 shows contribution of known and unknown activities and background/non-activity to the average total integrated daily exposure for 22 residences. The average total integrated daily exposure was $4.0 \cdot 10^5 \pm 3.5 \cdot 10^5 \text{ cm}^{-3} \cdot \text{h/d}$. Of this, the contribution from known activities was $2.7 \cdot 10^5 \pm 2.6 \cdot 10^5 \text{ cm}^{-3} \cdot \text{h/d}$ (66 %), from unknown activities $1.1 \cdot 10^5 \pm 1.9 \cdot 10^5 \text{ cm}^{-3} \cdot \text{h/d}$ (20 %), and from background/non-activity $3.6 \cdot 10^4 \pm 1.9 \cdot 10^4 \text{ cm}^{-3} \cdot \text{h/d}$ (14 %).

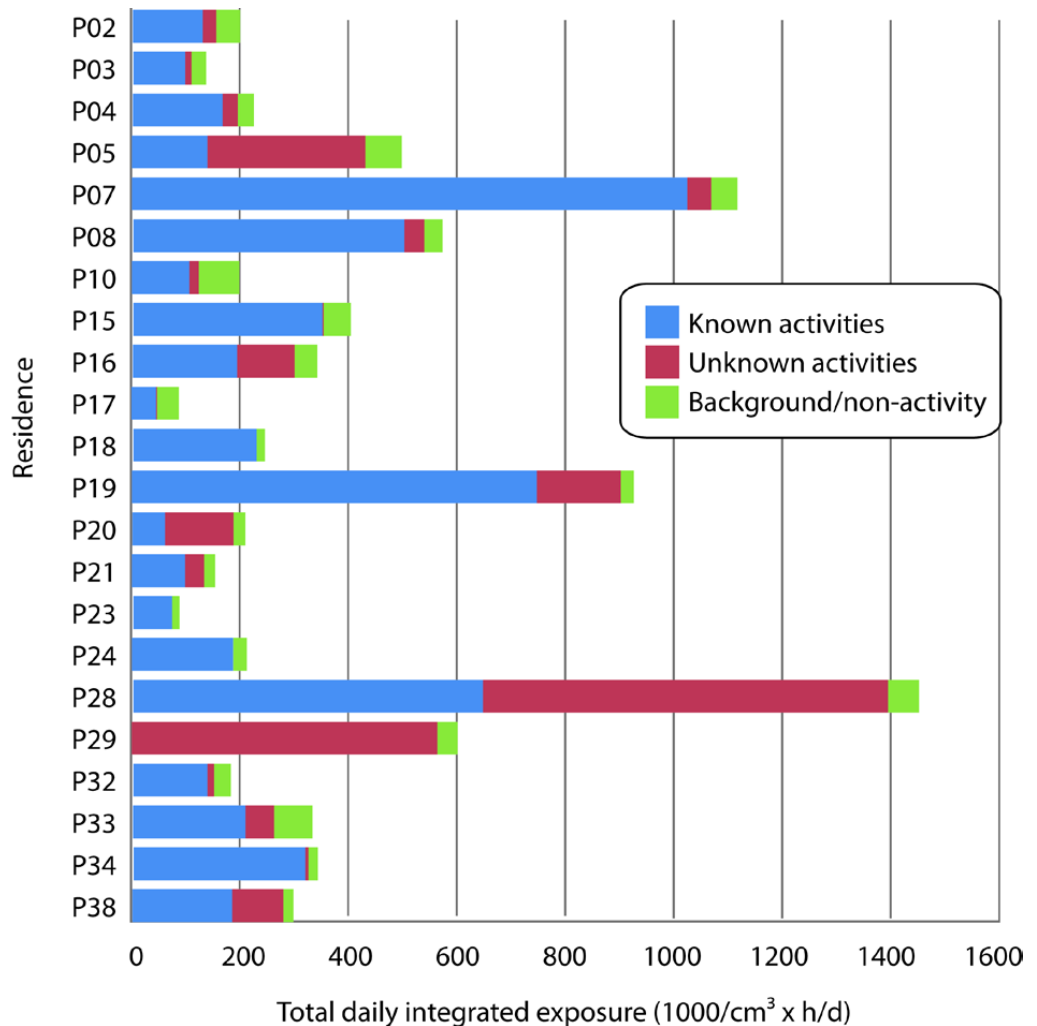
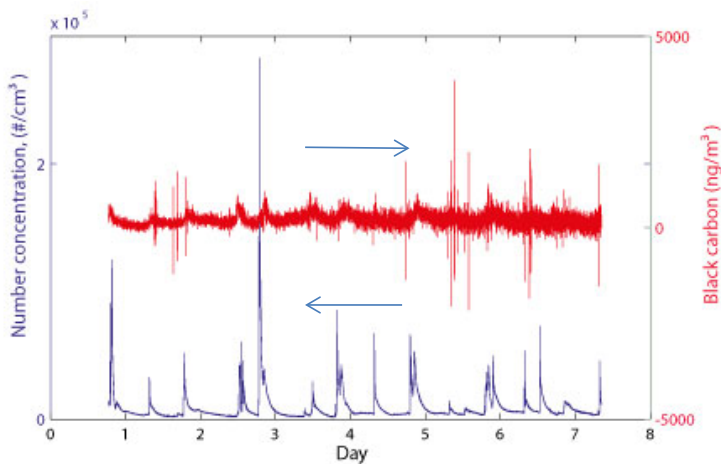

Figure 6. Total daily integrated exposure for 22 residences and the contribution of known and unknown activities and background/non-activity.

Total daily integrated exposure was calculated for the different known activities, to determine their specific contribution in each home (see supplementary material). In the 22 homes overall, cooking related activities (using a frying pan, boiling oven, micro, toaster and their combinations) contributed to the total daily integrated exposure with 31 % and candles with 26 %. In 6 of the homes, candles contributed with more than 60 %, and in two cases candles contribution reached 80 %. Candles have been reported earlier as significant contributors to high particle levels indoors, in this study we see the extent to which they contribute to daily integrated exposure during winter time in Sweden where candles are burned frequently.

Correlation between soot concentration and number concentration of particles < 300 nm

Soot indoors may originate from outdoors and/or from combustion related activities indoors. Contribution of indoor sources to soot levels indoors remains not fully understood. This was investigated by correlating data from microAeth (measures mass concentration of soot in total dust) and data from Nanotracer and DiSC (measures number concentration of particles < 300 nm). Using the ONA algorithm (Hagler et al., 2011) on soot data shown in Figure 9a makes comparison between the two instruments possible, as seen in Figure 9b.



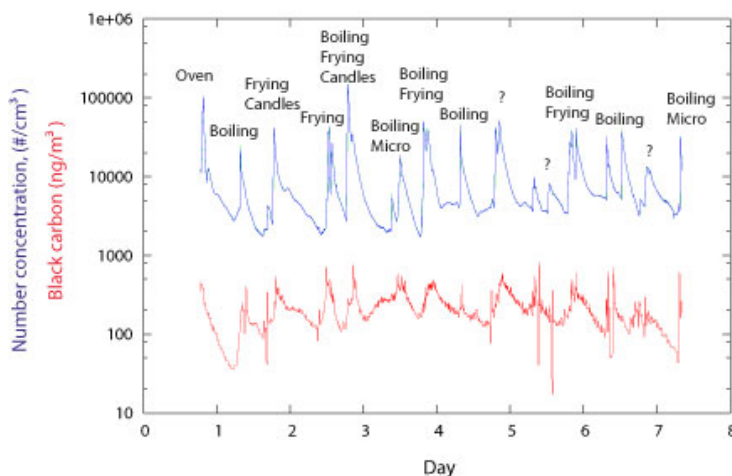

Figure 9a and b. Non-post-processed microAeth data (red) and Nanotracer data (blue) from one of the studied residences (a). Post-processed microAeth data (red) and Nanotracer data (blue) from the same residence (b).

As shown in Figure 9b, a majority of the peaks identified in the Nanotracer data could be identified also in the microAeth data, suggesting that the soot indoors, in this home, was actually generated indoors. Correlation factors were calculated for 10 homes by first calculating averages of the Nanotracer /DiSC data (data sampled every 16 s) to match the data of the microAeth (data sampled every 60 s). Correlation coefficients, r , between the two data sets were then calculated as:

$$r = \frac{1}{n-1} \sum_{i=1}^n \left(\frac{X_i - \bar{X}}{s_X} \right) \left(\frac{Y_i - \bar{Y}}{s_Y} \right)$$

where X_i and Y_i are the logarithms of the values from the Nanotracer/DiSC and microAeth respectively, n is the number of data points in one set, and \bar{X} and \bar{Y} (s_X and s_Y) are the corresponding means (standard deviations).

The correlation between particles <300 nm and mass concentration of soot in total dust in the 10 homes varied between 37 and 85 %, with an average of 56 %. In 3 homes, the correlations were higher than 60 %, in these homes activities consisted of cooking, candle burning (in two of them) and cigarette smoking (in one).

The correlations for given activities measured in 10 homes were checked and are summarized in Table 3. Correlation above 60 % was observed for smoking cigarettes, burning candles, cleaning and using microwave. Cleaning here relates to vacuuming, and soot content can be most probably explained as a result of emissions from the motor.

Table 3. Correlation between number concentrations of particles <300 nm and mass concentration of soot in total dust during specific activities.

Activity	Number of events	Correlation \pm Standard deviation (%)
Cigarettes	2	74 \pm 9
Candles	13	64 \pm 26
Cleaning	6	64 \pm 27
Microwave	2	61 \pm 11
Toaster	1	56
Frying	7	49 \pm 49
Oven	6	46 \pm 36
Laundry	1	46
Open window	4	44 \pm 38
Printer	1	38
Boiling	14	36 \pm 35

Discussion and Conclusions

Due to the importance of indoor sources, residential exposure to ultrafine particles cannot be characterized by ambient measurements alone, which has been clearly showed in this study. Comparison of number concentration frequency distributions (<300 nm) for 22 studied homes showed that outdoor concentrations can be used to describe concentrations in residences only during the time when occupants are not at home (which is not interesting from the exposure assessment perspective) or when they are not involved in any activities. Concentrations indoors during activities, which comprise 33 % of time spent at home, are significantly different and influenced by indoor sources. In epidemiological studies, it is not uncommon to estimate the exposure of a population based on measurements from one outdoor station. If this approach would be used in the case of the homes studied here, the exposure estimation would only be approximately relevant when no activities at all are conducted at home (see Figure 4a), i. e. mainly when people are asleep.

Integrated daily residential exposure of particles < 300 nm was on average $4.0 \cdot 10^5 \pm 3.5 \cdot 10^5 \text{ cm}^{-3} \cdot \text{h/d}$, where known indoor activities contributed to 66 % of integrated daily residential exposure (which agrees well with results published by Bekö et al (2013), Bhangar et al (2011), Mullen et al (2011) and Wallace and Ott (2011)), unknown activities 20 % and outdoor particles 14 %. It has to be noted that the study was performed in Northern Europe where outdoor air pollution is relatively low, and during winter time, when it is common to burn candles (which contribute significantly to the particle number concentration).

Emission factors ranged from $1.6 \cdot 10^{12}$ to $4.5 \cdot 10^{12} \text{ min}^{-1}$, which is in accordance with results reported by e.g. Wallace and Ott (2011).

Soot mass concentration measurements correlate well to measurements of particles < 300 nm in the case of cooking related activities (except for boiling), candle burning and cigarette smoking. The relatively high correlation in the case of cleaning (64 %) is most likely due to the particles emitted from the engine of the vacuum cleaner. The activities for which the correlation is the highest coincide with the activities which generate the highest number concentrations of particles < 300 nm (Figure 2).

Indoor sources are of a transient nature. They quickly generate high peaks in concentration which decay at a rate mainly determined by the air exchange rate and deposition mechanisms. It is not clarified whether it is the long term mean exposure or the events with elevated concentrations that has the greatest impact on human health. Until this has been further investigated and determined, it is of importance to gather exposure data based on high time resolution instruments. It is also crucial to be able to identify and characterize the sources. In this study, this has been done by asking the residents to fill in detailed activity log books. These documents are not fully reliable (difficult to interpret, lack of consistency, parts not filled in etc.) thus they are rather a blunt means of gathering important information, and probably the major limitation of this study. For future studies, use of some other way of source identification, such as sensors giving information about operation of stove, oven, toaster, window, door opening, maybe in combination with GPS equipment worn by occupants allowing accurate location determination (occupancy/non-occupancy time), could be recommended. If all activities (or at least the major part) could be known (see Figure 6) the exposure could be estimated based on information of the resident's living habits.

Another limitation of the study is the accuracy of used instruments. Asbach et al. reported that the Nanotracer overestimated particle number concentrations by a factor of ~ 7 for di(2-ethylhexyl) sebacate particles with a modal diameter of 180 nm, which is above the instrument's upper range for the mean diameter (120 nm). However, chamber experiments with candle smoke (resulting in the highest concentrations measured in this study) proved the opposite i.e. underestimation of measured concentration by Nanotracer for the sizes between 20 and 120 nm (Bekö et al., 2013). Only 20 % of measurement points in this study showed measured average diameter above 120 nm (mainly occurring during non-activity time), thus it is believed that presented results are not overestimated more than the assessed instrumental accuracy i.e. 30%.

Strictly speaking, the results of this study can only represent the 22 households studied during the time period in the winter when the measurements were conducted. The households were chosen from randomly selected addresses. However, only households where inhabitants accepted to be included in the studies became objects of measurements. The results may be regarded as representative for a community in Southern Scandinavia with around 100 000 inhabitants. There are, however, other studies that supports the general conclusion that periods of various activities in dwellings dominate the sources which cause the major exposures to the inhabitants. More studies are needed in order to be able to generalize on a national, continental or global scale. This study can together with many other studies contribute to such a generalized knowledge.

References

- Afshari A., Matson U., Ekberg L.E., (2005) Characterization of indoor sources of fine and ultrafine particles: a study conducted in a full-scale chamber. *Indoor Air* 15: 141-150.
- Araujo J.A., Baraja B., Kleinman M., Wang X.P., Bennett B.J., Gong K.W., Navab M., Harkema J., Sioutas C., Lulis A.J. and Nel A (2008) Small ambient particulate pollutants in the ultrafine range promote atherosclerosis and systemic oxidative stress. *Circulation*, 102: 589-596.

Asbach, C., Kaminski, H., Von Barany, D. Kuhlbusch, T.A.J., Monz, C., Dziurawitz, N., Pelzer, J., Vossen, K., Berlin, K., Dietrich, S., Gotz, U., Kiesling, H.J., Schierl, R., Dahmann, D. (2012). Comparability of Portable Nanoparticle Exposure Monitors. *Annals of Occupational Hygiene*, 56: 606-621.

Bekö G., Lund T., Nors F., Toftum J., Clausen G (2010). Ventilation rates in the bedrooms of 500 Danish children. *Building and Environment* 45: 2289-2295

Bekö G., Weschler C.J., Wierzbicka A., Karotki D.G., Toftum J., Loft S., Clausen G. (2013). Ultrafine particles: Exposure and source apportionment in 56 Danish homes. *Environmental Science and Technology* 47(18): 10240-10248.

Bhangar S., Mullen N.A., Hering S.V., Kreisberg N.M., Nazaroff W.W. (2011). Ultrafine particle concentrations and exposures in seven residences in northern California. *Indoor Air* 21: 132-144

Brasche S. and Bischof W. (2005). Daily time spent indoors in German homes – baseline data for the assessment of indoor exposure of German occupants. *International Journal of Hygiene and Environmental Health* 208: 247-253

Burney P.G., Chinn S. (1987). Developing a New Questionnaire for Measuring the Prevalence and Distribution of Asthma. *Chest Journal* 91(6): 79S-83S

Burney P.G., Laitinen L.A., Perdrizet S., Huckauf H., Tattersfield A.E., Chinn S., Poisson N., Heeren A., Britton J.R., Jones T. (1989). Validity and repeatability of the IUATLD (1984) Bronchial Symptoms Questionnaire: an international comparison. *European Respiratory Journal* 2(10): 940-945

Cheng Y-H., Lin M-H. (2013) Real-time performance of the microAeth AE51 and the aerosol loading effects on its measurement results at a traffic site. *Aerosol Air Quality Research* 13: 1853–1863

Dennekamp M., Howarth S., Dick C. A. J., Cherrie J. W., Donaldson K., Seaton A. (2001). Ultrafine particles and nitrogen oxides generated by gas and electric cooking. *Occupational and Environmental Medicine* 58: 511–516

Géhin E., Ramalho O., Kirchner S. (2008) Size distribution and emission rate measurement of fine and ultrafine particle from indoor human activities. *Atmospheric Environment* 42: 8341-8352

Hagler G.S.W., Yelverton T.L.B., Vedantham R., Hansen A.D.A., Turner J.R. (2011). Post-processing method to reduce noise while preserving high time resolution in Aethalometer real-time black carbon data. *Aerosol Air Quality Research* 11: 539-546.

He C., Morawska L., Hitchins J., Gilbert D. (2004). Contribution from indoor sources to particle number and mass concentrations in residential houses. *Atmospheric Environment*, 38(21): 3405-3415.

Hirano S. (2009). A current overview of health effect research on nanoparticles. *Environment of Health and Preventive Medicine* 14: 223-225.

Hussein T., Glytsos T., Ondráček J., Dohányosová P., Zdimal V., Hämeri K., Lazaridis M., Smolik J., Kulmala M. (2006) Particle size characterization and emission rates during indoor activities in a house. *Atmospheric Environment* 40: 4285-4307.

Kennedy I.M. (2007). The health effects of combustion-generated aerosols. *Proceedings of the Combustion Institute*, 31, 2757-2770.

Leech J., Nelson W., Burnett R., Aaron S., Raizenne M (2002). It's about time: A comparison of Canadian and American time-activity patterns. *Journal of Exposure Analysis and Environmental Epidemiology* 12: 427-432.

Lioy, P.J., Wainman, T., Zhang, J.J. (1999). Typical household vacuum cleaners: the collection efficiency and emissions characteristics for fine particles. *Journal of Air Waste Management Association* 49:200-206.

Liu D.L., Nazaroff W.W. (2003). Particle penetration through building cracks. *Aerosol Science and Technology* 37(7): 565-573.

Lundgren D.A. and Burton R.M. (1995). Effect of particle size distribution on the cut point between fine and coarse ambient mass fractions. *Inhalation Toxicology* 7: 131-148.

Morawska L. and Salthammer T., 2003. *Indoor Environment. Airborne Particles and Settled Dust.* WILEY-VCH, Weinheim.

Morawska L., Keogh D.U., Thomas S.B., Mengersen K. (2008). Modality in ambient particle size distributions and its potential as a basis for developing air quality regulation. *Atmospheric Environment* 42: 1617-1628.

Morawska L., Afshari A., Bae G.N., Buonanno G., Chao C. Y. H., Hänninen O., Hofmann W., Isaxon C., Jayaratne E. R., Pasanen P., Salthammer T., Waring M, Wierzbicka A. (2013). Indoor aerosols: from personal exposure to risk assessment. *Indoor Air* 23(6): 467-487. Nazaroff W.W. (2004): Indoor particle dynamics. *Indoor Air* 14(s7): 175-183.

Mullen N.A., Liu C., Zhang Y., Wang S., Nazaroff W.W. (2011). Ultrafine particle concentrations and exposures in four high-rise Beijing apartments. *Atmospheric Environment* 45: 7574-7582.

Nazaroff W.W. (2004). Indoor particle dynamics. *Indoor Air* 14: 175-183.

Oberdörster G., Oberdörster E. and Oberdörster J. (2005). Nanotoxicology: an emerging discipline evolving from studies of ultrafine particles. *Environmental Health Perspectives* 113: 823-839.

Thatcher T., Lunden M., Revzan K., Sextro R., Brown N. (2003). A concentration rebound method for measuring particle penetration and deposition in the indoor environment. *Aerosol Science and Technology* 37: 847-864.

Tracy L. Thatcher T.L., Lunden M.M., Revzan K.L., Sextro R.G., Brown N.J. (2003). A Concentration Rebound Method For Measuring Particle Penetration And Deposition In The Indoor Environment. *Aerosol Science and Technology* 37(11): 847-864

Turpin, B.J., Weisel, C.P., Morandi, M., Colome, S. and Stock, T. (2007) Relationships of Indoor, Outdoor, and Personal Air (RIOPA): Part II. Analyses of Concentrations of Particulate Matter species, Health Effects Institute, Report 130, Part II (Available at www.healtheffects.org)

Wallace L. (2006). Indoor sources of ultrafine and accumulation mode particles: size distributions, size-resolved concentrations, and source strengths. *Aerosol Science and Technology* 40: 348-360.

Wallace L. and Ott W. (2011). Personal exposure to ultrafine particles. *Journal of Exposure Science and Environmental Epidemiology* 21: 20-30.

Wan, M-P., Wu, C-L., Sze To, G-N., Chan, T-C. and Chao, C.Y.H. (2011) Ultrafine particles and PM_{2.5} generated from cooking in homes, *Atmospheric Environment*, 45(34): 6141-6148.

Wang S.M., Inthavog K., Wen J., Tu J.Y., Xue C.L. (2009). Comparison of micron- and nanoparticle deposition patterns in a realistic human nasal cavity. *Respiratory Physiology & Neurobiology*. 166: 142-151.

WHO (2005) Air Quality Guidelines Global Update 2005: Particulate matter, ozone, nitrogen dioxide and sulfur dioxide, Bonn, Germany.

Wierzbicka A. (2008). What are the characteristics of airborne particles that we are exposed to? Focus on indoor environments and emissions from biomass fired district heating. Doctoral thesis. Lund University, Sweden.

Article IV



Exposure and Emission Measurements During Production, Purification, and Functionalization of Arc-Discharge-Produced Multi-walled Carbon Nanotubes

Maria Hedmer^{1*}, Christina Isaxon², Patrik T. Nilsson²,
Linus Ludvigsson^{2,3}, Maria E. Messing^{3,4},
Johan Genberg⁵, Vidar Skaug⁶, Mats Bohgard²,
Håkan Tinnerberg¹ and Joakim H. Pagels²

1.Division of Occupational and Environmental Medicine, Department of Laboratory Medicine, Lund University, PO Box 118, SE-22100 Lund, Sweden

2.Ergonomics and Aerosol Technology, Lund University, PO Box 118, SE-22100 Lund, Sweden

3.Solid State Physics, Lund University, PO Box 118, SE-22100 Lund, Sweden

4.Synchrotron Radiation Research, Lund University, PO Box 118, SE-22100 Lund, Sweden

5.Nuclear Physics, Lund University, PO Box 118, SE-22100 Lund, Sweden

6.National Institute of Occupational Health, PO Box 8149, Dep 0033 Oslo, Norway

*Author to whom correspondence should be addressed. Tel: +4646173193; fax: +4646173180; e-mail: maria.hedmer@med.lu.se

Submitted 4 February 2013; revised version 29 October 2013; accepted 31 October 2013.

ABSTRACT

Background: The production and use of carbon nanotubes (CNTs) is rapidly growing. With increased production, there is potential that the number of occupational exposed workers will rapidly increase. Toxicological studies on rats have shown effects in the lungs, e.g. inflammation, granuloma formation, and fibrosis after repeated inhalation exposure to some forms of multi-walled CNTs (MWCNTs). Still, when it comes to health effects, it is unknown which dose metric is most relevant. Limited exposure data for CNTs exist today and no legally enforced occupational exposure limits are yet established. The aim of this work was to quantify the occupational exposures and emissions during arc discharge production, purification, and functionalization of MWCNTs. The CNT material handled typically had a mean length <5 µm. Since most of the collected airborne CNTs did not fulfil the World Health Organization fibre dimensions (79% of the counted CNT-containing particles) and since no microscopy-based method for counting of CNTs exists, we decided to count all particle that contained CNTs. To investigate correlations between the used exposure metrics, Pearson correlation coefficient was used.

Methods: Exposure measurements were performed at a small-scale producer of MWCNTs and respirable fractions of dust concentrations, elemental carbon (EC) concentrations, and number concentrations of CNT-containing particles were measured in the workers' breathing zones with filter-based methods during work. Additionally, emission measurements near the source were carried out during different work tasks. Respirable dust was gravimetrically determined; EC was analysed with

thermal–optical analysis and the number of CNT-containing particles was analysed with scanning electron microscopy.

Results: For the personal exposure measurements, respirable dust ranged between <73 and $93 \mu\text{g m}^{-3}$, EC ranged between <0.08 and $7.4 \mu\text{g C m}^{-3}$, and number concentration of CNT-containing particles ranged between 0.04 and 2.0cm^{-3} . For the emission measurements, respirable dust ranged between <2800 and $6800 \mu\text{g m}^{-3}$, EC ranged between 0.05 and $550 \mu\text{g C m}^{-3}$, and number concentration of CNT-containing particles ranged between <0.20 and 11cm^{-3} .

Conclusions: The highest exposure to CNTs occurred during production of CNTs. The highest emitted number concentration of CNT-containing particles occurred in the sieving, mechanical work-up, pouring, weighing, and packaging of CNT powder during the production stage. To be able to quantify exposures and emissions of CNTs, a selective and sensitive method is needed. Limitations with measuring EC and respirable dust are that these exposure metrics do not measure CNTs specifically. Only filter-based methods with electron microscopy analysis are, to date, selective and sensitive enough. This study showed that counting of CNT-containing particles is the method that fulfils those criteria and is therefore the method recommended for future quantification of CNT exposures. However, CNTs could be highly toxic not only because of their length but also because they could contain, for example transition metals and polycyclic aromatic hydrocarbons, or have surface defects. Lack of standardized counting criteria for CNTs to be applied at the electron microscopy analysis is a limiting factor, which makes it difficult to compare exposure data from different studies.

KEYWORDS: carbon nanotube; electron microscopy; elemental carbon; emission; exposure metric; manufactured nanoobject; nanoparticle; occupational exposure

INTRODUCTION

The global production and use of the carbon nanotubes (CNTs) into different products and materials is rapidly growing (Dahm *et al.*, 2012; Gasser *et al.*, 2012; Ono-Ogasawara and Myojo, 2013). CNT is in the paper used as a synonym for multi-walled CNTs. CNTs were discovered in 1991 by Iijima (1991) and are a heterogeneous group of tubes at the nanometre scale consisting of pure graphene layers rolled to form cylinders with high aspect ratios. If the CNT structure consists of one cylinder, it is denoted single-walled carbon nanotube (SWCNT) and if it consists of several cylinders stacked inside each other, they are referred to as multi-walled carbon nanotube (MWCNT).

Use and commercial application

CNTs are usually manufactured by three different methods, which are chemical vapour deposition (CVD), laser ablation, and arc discharge. CVD is the most common and widely used method for CNT production while the arc discharge method is lesser used. However, since arc-discharge-produced MWCNTs with a mean length $<5 \mu\text{m}$ are commercially available, occupational exposure during production with this method also need to be quantified.

CNTs have desirable properties in terms of mechanical strength, chemical inertness, electrical conductivity, optical properties, and thermal properties, and these truly unique properties may make a breakthrough in many vital industries (Barkauskas *et al.*, 2010). Therefore, wide application areas are expected for CNTs in the future in industry sectors such as materials and chemistry, medicine and life science, electronics, information and communication technology, and energy (Köhler *et al.*, 2008; Barkauskas *et al.*, 2010; McIntyre, 2012). Today, CNTs are incorporated into existing materials such as plastics, rubbers, composite materials, textiles, and concrete to make them more durable (strength), lightweight, or more wear-resistant (Schneider *et al.*, 2007; Köhler *et al.*, 2008; Wohlleben *et al.*, 2011). Products on the market today containing CNTs are, e.g. sport equipments, composites for car parts, aircrafts and wind power plants, and solar cells (Hussain *et al.*, 2006; Köhler *et al.*, 2008; Thomas *et al.*, 2009; Tan *et al.*, 2012). Workers exposed to CNTs may be at the highest risks while consumers are unlikely to be exposed to CNTs.

Toxicology and exposure metrics

The properties of CNTs differ depending on, e.g. number of walls, diameter, length, chiral angles, chemical

functionalization, purity, stiffness, and bulk density. CNT materials consist of a complex mixture of different transition metal catalysts, e.g. iron and cobalt, inorganic carbon impurities, and organic impurities, e.g. polycyclic aromatic hydrocarbons, which all could have a critical role in oxidative stress and the toxicology of CNTs (Plata *et al.*, 2008; Hsieh *et al.*, 2012). CNTs have nanoscaled size in two dimensions resulting in fibre-like characteristics and could be referred to as high aspect ratio nanoparticles (Donaldson *et al.*, 2011). The fibre shapes and the small dimensions result in very high surface to mass ratios. The structures of MWCNTs are stiffer compared with the SWCNTs. Membrane piercing of cells is mainly described for long and stiff CNTs with a length >15–20 μm (Nagai *et al.*, 2011; Gasser *et al.*, 2012). Since CNTs are fibre-like in their characteristics, there are structural similarity between them and asbestos fibres. Thus, concern has been raised if some forms of CNTs could induce similar adverse biological effects as asbestos, e.g. mesothelioma (Poland *et al.*, 2008; Donaldson and Poland, 2009; Donaldson *et al.*, 2011; Palomäki *et al.*, 2011). Animal studies have shown serious effects in the lungs, i.e. inflammation, granuloma formation, and fibrosis, after repeated inhalation exposure to MWCNTs (Ma-Hock *et al.*, 2009; Ryman-Rasmussen *et al.*, 2009; Pauluhn 2010; Porter *et al.*, 2013), even at realistic exposures and doses. Studies exposing the abdominal cavity in animals to MWCNTs indicated a certain carcinogenic potential (Poland *et al.*, 2008; Takagi *et al.*, 2008). Furthermore, recent studies clearly demonstrated threshold effects of the fibre length. Silver nanofibres with a length >4 μm were pathogenic and caused acute inflammation when the nanofibres were injected into the pleura (Schinwald *et al.*, 2012b). But if the silver nanofibres instead were administered by pharyngeal aspiration, the threshold fibre length for acute pulmonary inflammation was between 10 and 14 μm (Schinwald *et al.*, 2012a). Shorter CNTs entangle and coil and are preferentially enclosed by the cells (Nagai *et al.*, 2011). But shorter MWCNTs, for example with a median length of 3.9 μm , have in several studies shown to both penetrate alveolar macrophages, the alveolar wall, and visceral pleura (Mercer *et al.*, 2010) and cause pulmonary inflammatory effects and fibrosis (Mercer *et al.*, 2011; Porter *et al.*, 2013). Also, repeated exposure to very short MWCNTs (0.2–0.3 μm) has in rats shown to cause bronchoalveolar inflammation and thickening

of the alveolus septum indicative of interstitial fibrosis (Pauluhn, 2010). In the future, measurements of biological oxidative damage might be used as a biomarker for CNT exposure (Hsieh *et al.*, 2012). To date, no toxicological data for humans exist. Thus, exposure to all types of CNTs must be avoided as long as the adverse biological effects are not fully understood. Until the relevant dose metrics of CNTs are known, exposure to CNTs should be measured with multiple exposure metrics, for example mass concentration, elemental carbon (EC) mass concentration, and particle number concentration of CNT-containing particles (Brouwer *et al.*, 2012; Dahm *et al.*, 2012; Hedmer *et al.*, 2013).

Methods for measuring CNTs

How to collect and count CNTs on filters with electron microscopy is not obvious today due to a lack of standardized protocols. Based on the similarities between CNTs and asbestos, the method for standard fibre counting from World Health Organization (WHO, 1997) has been applied in a few previous studies of workplace exposure of CNTs (Bello *et al.*, 2009; Lee *et al.*, 2010). According to the WHO method, a fibre is counted if it has a minimum length of 5 μm , a width <3 μm , and length:width ratio >3:1 (WHO, 1997; OH Learning, 2010). Furthermore, if the fibre is attached to a non-CNT carrier particle, the carrier particle is neglected and the fibre is counted if the visible part of the fibre meets the above definition. Also, split fibres, fibre bundles, and ends of fibres partially within imaged area are counted. If >1/8th of the imaged area is covered with dust or particles, the area is rejected for counting and another area is chosen. The workplace studies that follow this method quantified no or few CNTs (Bello *et al.*, 2009; Lee *et al.*, 2010). Most airborne CNTs do not have these typical fibre dimensions due to agglomeration (Schulte *et al.*, 2012). Therefore, we decided to not apply the WHO standard fibre counting criteria and instead we counted every CNT-containing particle regardless of length. Furthermore, it is not clarified what will happen with the agglomerated CNTs that are deposited in the surfactant lining fluid in the lungs.

Workplace exposure

Since the use of CNTs is increasing and is predicted to do so even more strongly in the future, occupational exposure to CNTs can occur during the whole life cycle: production, purification, functionalization, incorporation in

different materials/products, use, repair, disposal, and end of life. Both the occupational exposure in terms of number of exposed workers and airborne concentrations of CNTs may increase if market expands and goes from small-scale production to mass production. Exposure through inhalation has been identified to be the dominating exposure route and potentially entailing the highest risk (Ma-Hock *et al.*, 2009; Pauluhn 2010; Gustavsson *et al.*, 2011; Porter *et al.*, 2013; Hedmer *et al.*, 2013). Thus, airborne exposures of CNTs need to be quantified and controlled, especially in open and manual handling of CNT powder.

Up to now, a limited number of studies have been carried out on workplace exposure to CNTs during production (Maynard *et al.*, 2004; Bello *et al.*, 2008; Han *et al.*, 2008; Lee *et al.*, 2010; Dahm *et al.*, 2012) and even fewer during specific steps in laboratory work such as purification and functionalization (Dahm *et al.*, 2012). Moreover, there are also very limited exposure data on machining of CNT composites (Bello *et al.*, 2009, 2010). To our knowledge, to date, no exposure data for arc-discharge-produced CNTs exist. Thus, the exposure data for airborne CNTs are still limited. In some studies, personal exposure measurements were performed during specific work tasks, e.g. during CVD production of CNTs, harvesting of CNTs, or weighing of CNT powder, and the sampling times were therefore short (Maynard *et al.*, 2004; Bello *et al.*, 2008; Dahm *et al.*, 2012).

Exposure limits

Today, no consensus occupational exposure limits for CNTs exist. The British Standards Institute (BSI) and the Institute for Occupational Safety and Health of the German Social Accident Insurance (IFA) have proposed benchmark exposure limits for fibrous nanomaterials with high aspect ratios ($>3:1$ and length $>5 \mu\text{m}$) set at $0.01 \text{ fibre cm}^{-3}$ (BSI, 2007; IFA, 2009). In Japan, a mass-based occupational exposure limit of $30 \mu\text{g m}^{-3}$ was proposed by the Japanese New Energy and Industrial Technology Department Organization (Nakanishi, 2011). The National Institute for Occupational Safety and Health (NIOSH, 2013) has recently proposed a recommended exposure limit for CNTs based on EC of $1 \mu\text{g C m}^{-3}$ as a respirable mass 8-hr-time-weighted average (TWA-8) concentration.

EC is typically measured with a thermal-optical method to divide the amount of carbonaceous material in a sample into organic carbon and EC. During

the EC analysis, a temperature program is used, where the carbonaceous material is oxidized in several temperature steps in the presence of a controlled amount of oxygen (e.g. 2% O_2). The amount of EC oxidized at each temperature step is then added together and reported as EC (Birch and Cary, 1996). According to Ono-Ogasawara and Myojo (2013), MWCNTs are mainly oxidized at temperatures $>700^\circ\text{C}$. They also suggested that EC in the two highest temperature classes (700 and 920°C) in their study can be used as qualitative indices of MWCNTs. Furthermore, if the MWCNTs have diameters $>20 \text{ nm}$, they were mainly measured in the highest temperature class (920°C). So far, only one study has used EC (inhalable fraction) as an exposure metric for CNTs during personal exposure measurements in production of CNTs (with CVD; Dahm *et al.*, 2012). However, the recommended exposure limit for EC proposed by NIOSH is based on the respirable mass (NIOSH, 2013). No exposure data based on single oxidation temperature classes are available today. In summary, very little information is available for occupational exposure to CNTs, and exposure and emission data from production of CNTs with the arc discharge technique are still missing.

Aim

The objective of this study was to quantify the occupational exposures and emissions to CNTs with a mean length $<5 \mu\text{m}$ and therefore, personal exposure measurements in the breathing zone of workers as well as emission measurements near the expected emission source were performed during production, purification, and functionalization of arc-discharge-produced MWCNTs. Respirable fractions of dust, EC, and number concentrations of CNT-containing particles were measured to obtain multiple exposure metrics for the CNT exposure. An evaluation of the used exposure metrics was also performed by studying the correlations between the investigated metrics.

METHODS

MWCNT producer

In this study, we had the opportunity to investigate occupational exposures and emissions of one of the few small-scale facilities producing MWCNTs using the arc discharge method. Also, other carbonaceous

nanoparticles such as cones and discs were occasionally produced by the company. In the company, three workers were involved in the production, purification, and functionalization work of MWCNTs. Schematic drawings of the production laboratory, sieving laboratory, and purification laboratory can be seen in Fig. 1. A description of the production methods and the work tasks in the production laboratory, sieving laboratory, and purification laboratory is given below.

Production

The production of MWCNTs took place in the production laboratory and sieving laboratory. The company had an arc discharge reactor for the MWCNT production. The arc discharge method is based on application of a high-voltage field over two rods composed of high-purity graphite. The rods serve as electrodes, an anode and a cathode, and a stable arc discharge is formed between them. The MWCNTs grow on the cathode while the anode is consumed. With this production method, no metal catalysts are

required and the metal impurities can therefore be very low. However, non-CNT-containing impurities (e.g. graphite and soot) are produced by this method, so purification steps are challenge when scaling up the production. According to the manufacturer, the produced MWCNTs consisted of 55 wt% CNTs and 45 wt% graphite nanoparticles and other graphitic structures. The produced MWCNTs had diameters between 2 and 50 nm and a typical length of $>2 \mu\text{m}$ according to the producer. According to scanning electron microscopy (SEM) analysis on bulk material obtained from the company during the sampling campaign, the mean length of the individual MWCNTs was $1.7 \mu\text{m}$ with a distribution ranging from 0.3 to $6.1 \mu\text{m}$. Compared with the critical dimensions of fibres, the majority of produced MWCNTs in the studied company had a length $<5 \mu\text{m}$. The production included the following work tasks: synthesizing of MWCNTs with the enclosed arc discharge reactor, opening of reactor, and collection of reacted graphite deposit (No. 3 in Fig. 1), dry cutting of reacted graphite deposit with a band saw (No. 1 in Fig. 1), manual

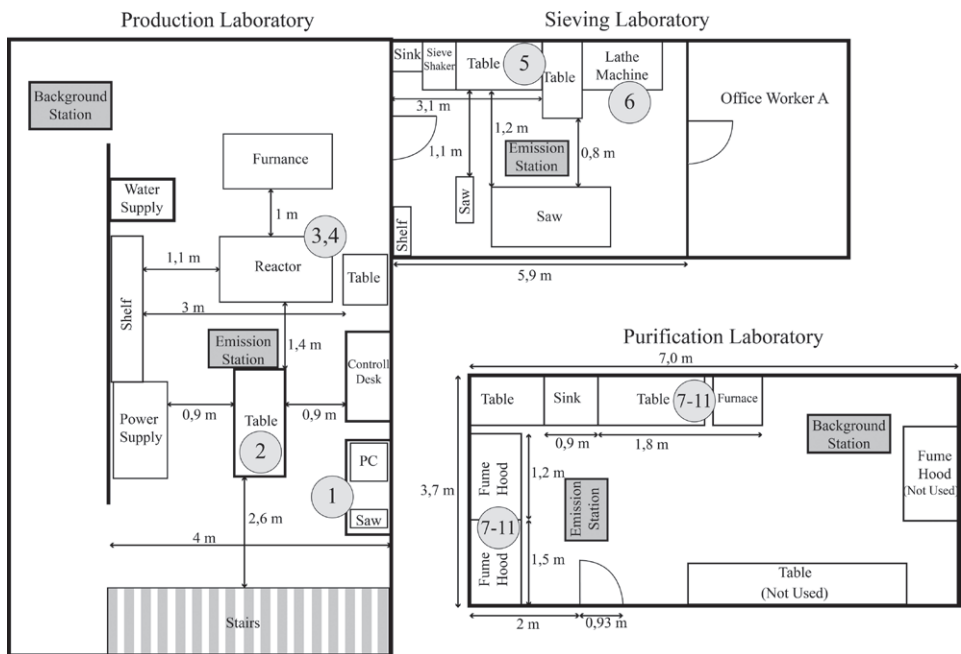

1 Schematic drawing of the facility. The numbers in grey circles correspond to activities in Table 4. The production laboratory and sieving laboratory were located on a different floor than the purification laboratory.

harvesting of produced MWCNTs (No. 2 in Fig. 1), mechanical work-up, sieving, weighing, pouring, and packaging (No. 5 in Fig. 1), lathe machining of graphite rods for the reactor (No. 6 in Fig. 1), and reactor clean out with compressed air and a vacuum cleaner with high efficiency particulate absorption (HEPA) filter (No. 4 in Fig. 1). Worker A was responsible for the above-described work tasks of which several of these included open handling of MWCNT powder.

Purification and functionalization

In the purification laboratory, the produced MWCNTs were purified to remove carbonaceous structures, e.g. graphite and soot. According to the company, the purified MWCNTs consisted of 80 wt% CNTs and 20 wt% graphite nanoparticles and other graphitic structures. Functionalization of purified MWCNTs also took place there. Workers B and C were responsible for the work tasks performed in the purification laboratory. Most work tasks were defined as laboratory work and were performed inside the two fume hoods (No. 7–11 in Fig. 1). Work tasks performed inside the fume hoods were, for example pouring of MWCNT powder, dispersion of MWCNT powder, filtration of MWCNT dispersion, grinding of CNTs (No. 11 in Fig. 1). The workers poured and weighed MWCNT powder, packed MWCNT powder into containers, and dried MWCNT powder in a furnace and these work tasks were performed outside the fume hoods.

Workplace monitoring

Strategy for air sampling

The personal exposure measurements and emission measurements of workplace air were performed in the facility during two consecutive work days, and an overview of the sampling strategy can be seen in Table 1. Three different exposure metrics (respirable fractions of mass concentration, EC, and number concentration of CNT-containing particles) were used.

Personal exposure measurements

Time-integrated sampling with filter-based methods was performed on Workers A–C. The respirable fraction of dust samples (50% cut-off at an aerodynamic equivalent particle diameter of 4 µm), EC samples, and SEM samples were collected in the breathing zone of the workers. Also, sampling with direct-reading personal aerosol monitors was carried out to be able to assess respirable mass concentrations and particle number concentrations. The direct-reading instruments and the EC sampling were used at one department per day (Table 1). Respiratory protection was used by Worker A in the production laboratory and sieving laboratory. Thus, the sampling was performed outside the half-face respirator equipped with particulate filter of Grade P3.

Table 1. The sampling strategy for the exposure and emission measurements at the small-scale producer of MWCNTs

Sampling day	Production laboratory and sieving laboratory		Purification laboratory	
	Personal exposure measurement during the work day	Short-term emission measurement	Personal exposure measurement during the work day	Short-term emission measurement
1	Sampling of: R1, R2, SP, NT	Sampling of: R1, R2 for each work task; EC for select work tasks	Sampling of: R1, R2, EC	—
2	Sampling of: R1, R2, EC	—	Sampling of: R1, R2, SP, NT	Sampling of: R1, R2 for each work task; EC for select work tasks

R1, respirable dust mass concentration by gravimetric analysis; R2, respirable CNT-containing particles by SEM analysis; SP, Sidepak (Photometer), assessment of respirable mass concentration; NT, Nanotracer, assessment of particle number concentration and mean size; EC, respirable elemental carbon by thermal-optical analysis; —, not measured.

Emission measurements

Emission measurements of released MWCNTs at the specific work tasks previously described during production, purification, and functionalization work were conducted in the emission zone. The inlet of the sampling line of stainless steel was placed as close as possible to the expected emission source, typically at a few centimetre distance. The sampling line had a diameter of 6 mm and a total length of 1 m. The sampling line was split into three lines and these were connected to three filter cassettes for sampling of respirable dust, EC, and SEM, respectively. This we refer to as the emission station, which was moved for each work task.

Respirable dust samples

Personal samples and static emission samples of respirable dust were collected using cyclones (BGI4L, BGI Inc., Waltham, MA, USA) on 37-mm cellulose fibre filters with a pore size of 0.45 μm (SKC Inc., Eighty Four, PA, USA) mounted in plastic three-piece filter cassettes. An Escort ELF pump (MSA, Pittsburgh, PA, USA) set at 2.2 l min^{-1} provided sample flow. The air flow rate was before, during, and after the sampling regularly checked with a primary calibrator (TSI Model 4199, TSI Inc., Shoreview, MN, USA). The filters were preweighed and postweighed using an analytical balance (XP105 DeltaRange Excellence Plus, Mettler Toledo, Greifensee, Switzerland). The balance was located in a temperature- and humidity-controlled room. A 24-h equilibration period was applied before weighting. The limit of detection (LOD) of the gravimetric analysis was determined to 50 μg collected material per sample.

EC samples

Personal samples and static emission samples of respirable EC were collected according to the same procedure as described for respirable dust samples. However, preheated (at 800°C) 37-mm quartz filters (SKC Inc., Eighty Four, PA, USA) were used. Flow control and checks were carried out in the same way as described for respirable dust samples. Bulk samples of purified MWCNTs and the filters from the air sampling were analysed according to the NIOSH NMAM 5040 protocol with thermal-optical analysis (DRI Model 2001 OC/EC Carbon Analyzer from Atmoslytic Inc., Calabasas, CA, USA) (Birch and Cary, 1996). The

following temperature steps were used: 680°C (EC1), 750°C (EC2), and 900°C (EC3). However, the method was modified with a prolonged oxidation time, 150 s instead of 30 s, at the highest reached temperature, 900°C, to strive for complete oxidation of all carbonaceous compounds. The carbon mass detected in each temperature step was denoted EC1–EC3 as described above. Typical thermograms for the bulk material and a filter sample are shown in [Supplementary Figure S1](#) (available at *Annals of Occupational Hygiene* online). Since the emitted MWCNTs mainly had diameters >20 nm and thereby could be expected to be mainly measured as EC3, we also chose to report the measured EC3 values (900°C). For the bulk samples, on average, 57% of the EC was measured as part of EC3. The LOD for EC was determined to be 0.06 $\mu\text{g C sample}^{-1}$ (about 0.08 $\mu\text{g C m}^{-3}$ for a 6-h sample)

Electron microscopy samples

Personal samples and static emission samples of respirable dust were collected on 37-mm non-fibrous polycarbonate membrane filters with a pore size of 0.4 μm (SKC Inc., Eighty Four, PA, USA) mounted in plastic three-piece filter cassettes. The same sampling procedure as described above was used. Analysis was performed with SEM (FEI Nova Nanolab 600, FEI Company, Hillsboro, OR, USA). With the used SEM method, a piece corresponding to approximately a quarter of the polycarbonate filter was mounted on a silicon wafer and coated with platinum. The visible LOD was >35 nm (1 pixel) but during the SEM analysis, it was possible to see particles with sizes >10 nm if a higher magnification was used, and this will be discussed further on. The SEM analysis was done at images with a standard resolution of 3584 × 3301 pixels. At least five but up to 29 areas per filter were randomly chosen for image acquisition. Each imaged area was 9050 μm^2 . The standard deviation of the derived concentrations of CNT-containing particles varied between ± 10 and $\pm 50\%$ for the reported samples. All CNT-containing particles imaged by the SEM were manually counted and defined as any particle with visible CNT content. In comparison with SEM analysis of asbestos according to the WHO method, we counted both fibres that fulfilled the asbestos counting criteria (length of >5 μm , width <3 μm , and length:width ratio >3:1) and those which did not

(WHO, 1997). If several fibres were attached to a particle, it was counted as one CNT-containing particle. This differs to how asbestos is counted; if the asbestos fibre is attached to a particle, it is then assessed as if the particle does not exist and is counted if the visible part of the fibre meet the above definition (OH Learning, 2010). Based on the sampled air volume, the number of CNT-containing particle cm^{-3} could be calculated. Analysis of blank filters as well as of field blanks showed that the used polycarbonate filters did not contribute with matrix particles/fibres. The calculation of the 95% confidence limits was based on ISO 10312 (1995). The elemental composition of the CNTs was analysed using an transmission electron microscopy with energy dispersive X-ray analyser (TEM/EDX; Jeol 3000F, Tokyo, Japan, and SDD XEDS, Oxford Instruments, Oxfordshire, UK).

Direct-reading instruments

Two direct-reading instruments commonly used in occupational hygiene were used for personal monitoring in the workers' breathing zone. A Nanotracer (Philips Aerasense, Eindhoven, The Netherlands) that was based on detection of electrical charges carried by particles, which have passed a unipolar corona charger in the device was used to monitor particle number concentrations. From this, the particle number concentration (10–300 nm) and mean particle (mobility) diameters were derived. The sampling flow rate was 0.24 l min^{-1} . A 0.51-m tubing was applied to be able to place the inlet of the Nanotracer in the breathing zone. Data were logged every 16 s. Additionally, a Photometer (model SidePak Model AM510, TSI Inc., Shoreview, MN, USA) equipped with a 0.91-m tubing connected to a 10-mm Dorr-Oliver cyclone (50% cut-off of $4 \mu\text{m}$) was used to assess the respirable mass concentration by illuminating a particle containing space and detect the light scattered against the particles. The SidePak used in the study was calibrated by the manufacturer using the respirable size fraction of Arizona test dust. Thus, the mass concentrations from measurements of non-spherical particles with unknown refractory index should be considered as indicative only. The air flow rate was set to 1.7 l min^{-1} with a primary calibrator (Model 4199, TSI Inc., Shoreview, MN, USA) and the instrument was set to log data every 1 s. Moreover, a condensation particle counter (Model CPC 3022, TSI Inc., Shoreview, MN, USA)

also simultaneously monitored the particle number concentration in the size range 0.01 and $>3 \mu\text{m}$ in the emission zone ($<10 \text{ cm}$ from the source).

Statistics

The correlation between the different exposure metrics was evaluated. The correlations were described with the Pearson correlation coefficient, r . Values below the LOD were given the value of half the LOD. The correlation between direct-reading instruments in the breathing zone (Nanotracer) and in the emission zone (CPC) was investigated. The sampling line residence time, which is not the same for the two instruments, was corrected for, and averages were calculated for the CPC data (data sampled every 1 s) to match the sampling time of the Nanotracer (every 16 s). Pearson correlation coefficients between the two data sets were calculated on log-transformed data as:

$$r = \frac{1}{n-1} \sum_{i=1}^n \left(\frac{X_i - \bar{X}}{s_X} \right) \left(\frac{Y_i - \bar{Y}}{s_Y} \right)$$

where X and Y are the data set from the Nanotracer and CPC, respectively, n is the number of data points in one set, \bar{X} and \bar{Y} are the sample means, and s_X and s_Y are the sample standard deviations.

RESULTS

Personal exposure measurements

Personal exposure measurements during production and laboratory work with MWCNTs were conducted, and the mean sampling time was 5.7 h (range 5.2–6.7 h). The measured concentrations of respirable dust, respirable EC, and number concentrations of CNT-containing particles (respirable fractions) are presented in Table 2. Arithmetic means of the respirable dust concentrations during the production of MWCNTs were $86 \mu\text{g m}^{-3}$ (range 93 and $79 \mu\text{g m}^{-3}$) and $<73 \mu\text{g m}^{-3}$ during purification and functionalization work, respectively. Respirable EC was measured during one of the two sampling days and EC was only quantified during work in the production and sieving laboratory ($7.4 \mu\text{g C m}^{-3}$).

The personal exposure measurements showed that both workers in the production laboratory and sieving laboratory as well as in the purification laboratory were

Table 2. Results from the personal sampling in the breathing zone of respirable dust, EC, and number concentration of CNT-containing particles. The sampled air volumes ranged between 680 and 890 l. EC is the actual concentration and EC3 is the amount found for the highest oxidation temperature step (900°C)

Worker	Location	Sampling day	Sampling time (min)	Respirable dust concentration ($\mu\text{g m}^{-3}$)	Respirable EC concentration ($\mu\text{g C m}^{-3}$)		CNT-containing particles ($\# \text{cm}^{-3}$)
					EC	EC3	
A	Production laboratory and sieving laboratory	1	341	93	—	—	0.6
A	Production laboratory and sieving laboratory	2	405	79	7.4	6.3	2.0
B + C ^a	Purification laboratory	1	324	<71 ^b	<0.08	<0.08	0.04
B + C	Purification laboratory	2	313	<73 ^b	—	—	0.1

—, not sampled.

^aThe two workers in the purification laboratory worked there only partly during a shift. They did only occasionally work there at the same time. Therefore, one sampler was used and swapped between Workers B and C.

^bLOD.

exposed to MWCNTs. The worker in production was exposed to the highest number concentration of CNT-containing particles, in mean 1.3 cm^{-3} CNT-containing particles (range 0.6–2.0). The workers in the purification laboratory work had a mean exposure of 0.07 cm^{-3} CNT-containing particles (range 0.04–0.1). Thus, the MWCNT exposure during production was about an order of magnitude higher in comparison with the laboratory work. In Fig. 2, two types of common airborne CNT-containing particles are shown.

The highest personal respirable dust concentration ($93 \mu\text{g m}^{-3}$) was not measured during the same day as the highest number concentration of CNT-containing particles. Thus, emission sources releasing other types of particles than CNTs contribute with particle mass. SEM analysis of the polycarbonate filters showed that airborne particles other than CNT-containing ones dominated by number in the respirable size range. The sampled particles consisted of pure soot agglomerates, raw production materials (graphite), particles from the sieve (containing CNTs), and a large amount of small particles ($<0.3 \mu\text{m}$) that may be partly infiltrated from ambient air. Unfortunately, no EC sample was collected parallel to this SEM sample. EDX analysis of the CNT material in this study showed that the material did not contained any transition metal catalysts.

A summary of the respirable mass concentrations, particle number concentration, and mean particle size obtained from the personal exposure measurements with the direct-reading instruments can be seen in Table 3. A time series from the measurement of assessed respirable mass concentration in the production laboratory is shown in Fig. 3. The direct-reading instrument (Sidepak) showed the highest peak exposure during the reactor clean out Part I. However, the filter-based SEM sample collected during this specific work task showed no presence of CNT-containing particles, indicating that the emitted particles from the clean out consisted of other carbonaceous particles, such as soot and graphite. The direct-reading instrument used for personal exposure measurements of particle number concentration (Nanotracer) measured the highest peak concentration during lathe machining of graphite rods, up to $34\,000 \text{ particles cm}^{-3}$ (Fig. 4a). The mean diameter of the particles released during lathe machining was small, $\sim 30\text{--}40 \text{ nm}$. Sampling in the purification laboratory during Day 2 showed a much higher background concentration, on average $11\,000 \text{ particles cm}^{-3}$ a.m., compared with the average concentrations between 1800 and $2500 \text{ particles cm}^{-3}$ in the production laboratory and sieving laboratory (Table 3). It is possible that thermal sources such as a furnace that was

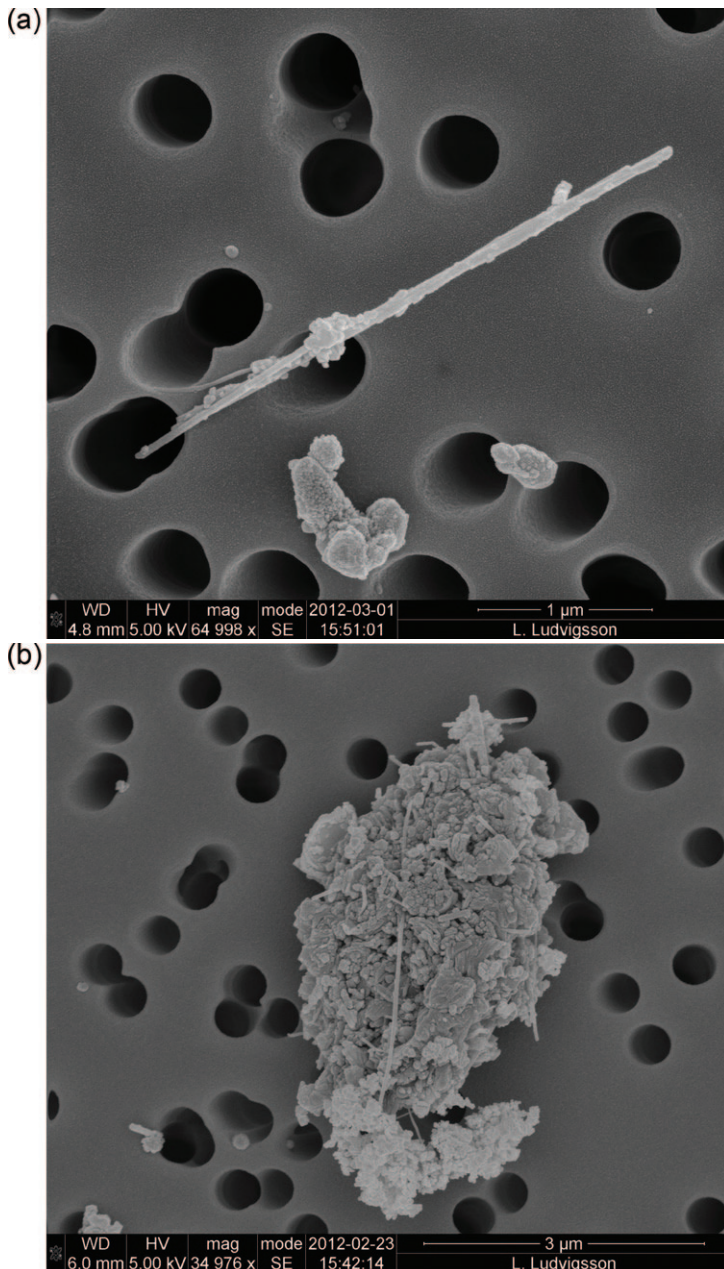

2 Two different types of airborne CNT-containing particles in the collected respirable dust fractions. (a) Individual CNTs were found in 21% of the counted particles. (b) The most frequent counted type of CNT-containing particles; large agglomerates (59%).

Table 3. Summary of the personal sampling with direct-reading instruments

Sampling day	Location	Respirable mass concentration ^a (arbitrary units)			Particle number concentration ^b (# cm ⁻³)			Average particle size ^b (nm)		
		Arithmetic mean	Min	Max	Arithmetic mean	Min	Max	Arithmetic mean	Min	Max
1 (a.m.)	Production laboratory and sieving laboratory	0.04	ND	1.7	1800	500	12 000	59	40	86
1 (p.m.)	Production laboratory and sieving laboratory	0.23	ND	5.6	2500	500	34 000	65	32	92
2 (a.m.)	Purification laboratory	0.10	ND	3.2	11 000	2400	280 000	50	22	70
2 (p.m.)	Purification laboratory	0.06	ND	2.8	3800	1700	3800	64	42	86

ND, not detected.

^aSidepak (Photometer); the reported concentration is the respirable mass concentration assuming that the workplace aerosol has the same instrument response as the calibration aerosol (Arizona test dust).

^bNanotracer (based on unipolar electrical charging and size classification by electrical mobility, 10–300 nm).

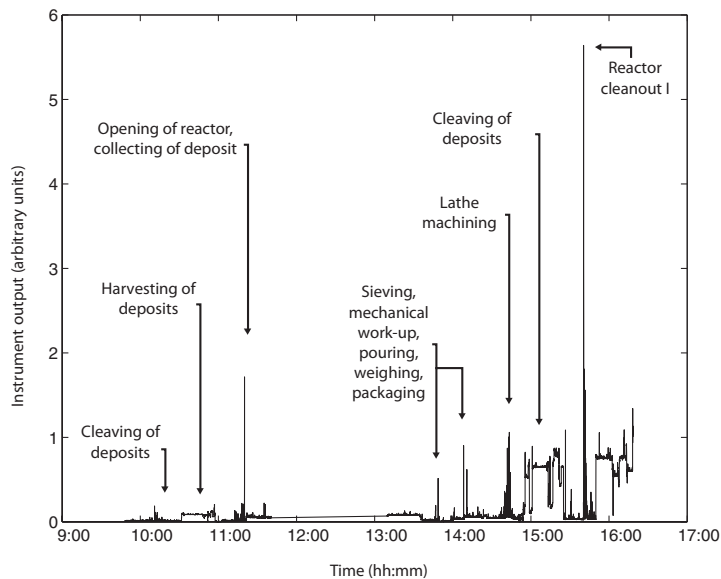

3 Personal sampling of respirable dust with direct-reading instrument (Sidepak) on Worker A during production of MWCNTs.

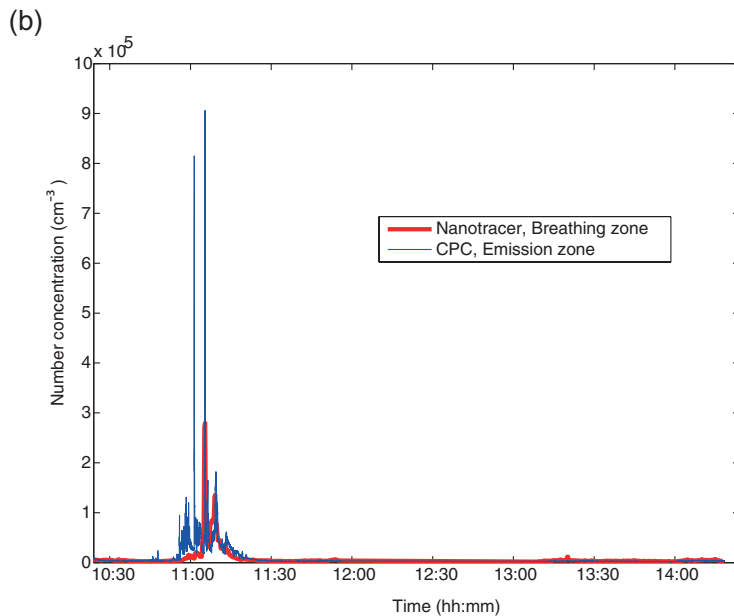
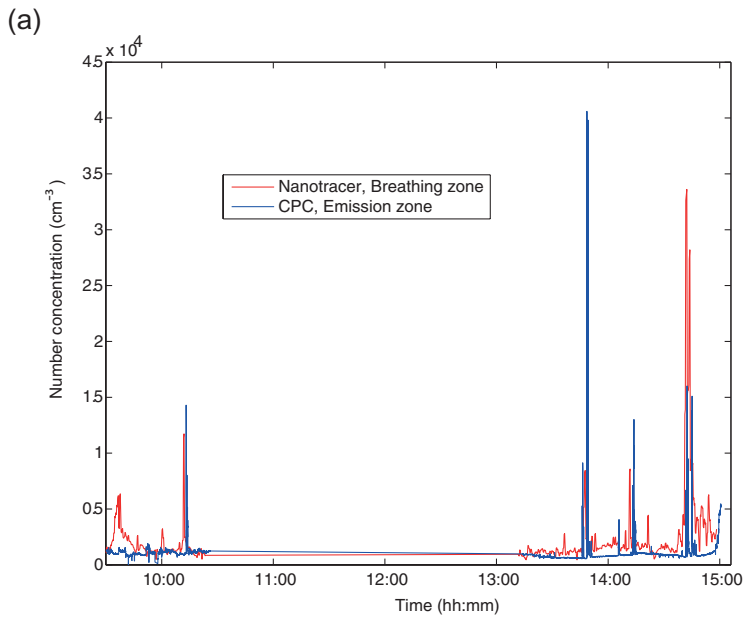

4 Personal sampling with direct-reading instrument (Nanotracer) and emission sampling with CPC during (a) production work and (b) purification and functionalization work of MWCNTs. (c) The distribution of the real-time data from the Nanotracer and CPC (reference instrument) shows that the correlation between the two instruments is higher for higher number concentrations. Nanotracer assesses the particle number concentration using a diffusion charging technique while the CPC allows a direct counting of individual particles (up to $10\,000\text{ cm}^{-3}$).

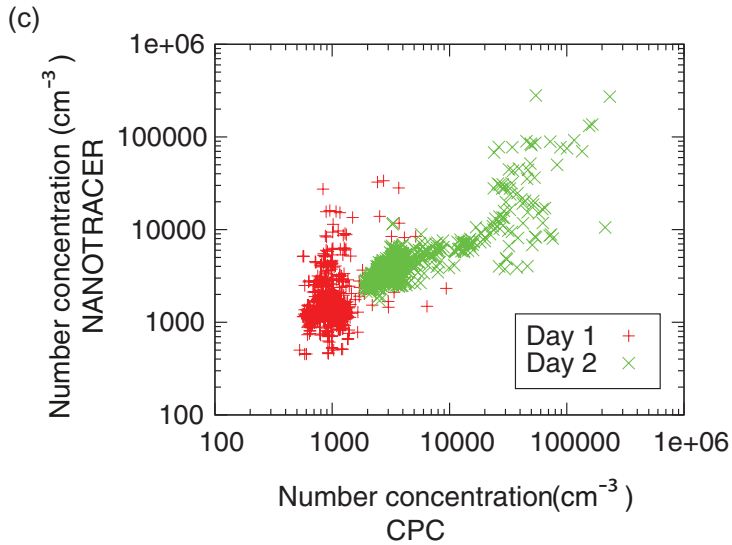

4 Continued

continuously forming non-CNT-containing particles from, for example heating of insulation etc. contributes to the high background in the purification laboratory. The highest release of nanometre-sized particles in the purification laboratory was measured during weighing of MWCNTs followed by opening of the furnace (Fig. 4b). The arithmetic mean diameter of these particles was ~20–30 nm. The measured particle number concentration from the personal exposure sampling (Nanotracer) was compared with emission data from a stationary CPC in the emission zone and the Pearson correlation coefficient was $r = 0.30$ for the measurements performed in the production laboratory and sieving laboratory (Fig. 4a). The corresponding value in the purification laboratory was 0.84 (Fig. 4b). The correlation of the real-time data from the Nanotracer (breathing zone) and CPC (emission zone) can be seen in Fig. 4c. With increased particle number concentrations, a stronger correlation between the instruments can be seen. A personal instrument (Nanotracer) could be used if the expected particle number concentrations in the work environment are not too low. But particle number concentrations measured by the CPC in the emission zone could also work as a proxy for the personal exposure.

Emission measurements

Emission measurements were performed at 12 different work tasks during production, purification, and functionalization work in the facility (Table 4). The sampling time ranged between 4 and 70 min. By sampling close to the emission source during different work tasks, important information of the emitted concentrations of each work task was obtained. In only one out of 12 emission samples from the emission zone could the respirable dust concentration be quantified above LOD. This was during a 4-min clean out of the arc discharge reactor with compressed air and vacuum cleaning (use of a vacuum cleaner equipped with HEPA filter) and a dust concentration of $6800 \mu\text{g m}^{-3}$ was measured. Also, the highest concentration of EC was measured during the clean out of the reactor. However, the SEM analysis showed no emission of CNT-containing particles during this work task. Most likely, the emitted particles consisted of other carbonaceous materials such as soot and amorphous carbon. The EC concentration measured at different work tasks ranged between 0.05 and $550 \mu\text{g C m}^{-3}$. The number concentration of CNT-containing particles released during production ranged between 0 and 11 CNT-containing particles cm^{-3} . The highest emission concentrations of CNT-containing

Table 4. Results from the emission measurements of respirable fractions of dust, EC, and number concentration of CNT-containing particles during different work tasks. EC is the total elemental carbon concentration and EC3 is the EC concentration found at the highest oxidation temperature step (900°C)

Work tasks	Location number in Fig. 1	Use of engineering controls/personal protective equipment	Respirable dust samples			Respirable EC samples			Microscopy samples		
			Air volume sampled ^a (l)	Mass concentration (1) ($\mu\text{g m}^{-3}$)	Air volume sampled ^a (l)	Mass concentration (1) ($\mu\text{g C m}^{-3}$)	Air volume sampled ^a (l)	Mass concentration (1) ($\mu\text{g C m}^{-3}$)	Air volume sampled ^a (l)	CNT-containing particles ^b (1) (# cm^{-3})	Calculated TWA (# cm^{-3})
			EC		EC3						
Production laboratory and sieving laboratory											
Opening of reactor, collecting the deposits	3	Local exhaust/half-face respirator ^c , nitrile gloves, protecting overall	24	<2100	18	140	91	18	ND (<1.0)	—	—
Cleaving of deposits	1	None/half-face respirator, nitrile gloves, protecting overall	26	<1900	20	470	460	24	1.6	—	—
Harvesting of MWCNTs from deposits	2	Local exhaust/half-face respirator, nitrile gloves, protecting overall	40	<1300	42	<1.4	<1.4	37	ND (<1.8)	—	—
Sieving, mechanical work-up, pouring, weighing, packaging	5	None/half-face respirator, nitrile gloves, protecting overall	117	<430	196 ^d	250 ^d	240 ^d	117	1.1	8.2 ^d	8.2 ^d

Table 4. Continued

Work tasks	Location number in Fig. 1	Use of engineering controls/personal protective equipment	Respirable dust samples		Respirable EC samples		Microscopy samples			
			Air volume sampled ^a (l) ($\mu\text{g m}^{-3}$)	Mass concentration (1) ($\mu\text{g m}^{-3}$)	Air volume sampled ^a (l)	Mass concentration (1) ($\mu\text{g C m}^{-3}$)	Air volume sampled ^a (l)	CNT-containing particles ^b (l) particles ^b ($\# \text{ cm}^{-3}$)	Calculated TWA ($\# \text{ cm}^{-3}$)	
			EC		EC3					
Lathe machining of graphite electrode	6	Local exhaust/half-face respirator, nitrile gloves, protecting overall	29	<1700	29		29		1.2	
Reactor clean out Part I	4	Local exhaust/half-face respirator, nitrile gloves, protecting overall	18	<2800	18		18		ND (<0.20)	
Reactor clean out Part II	4	Local exhaust/half-face respirator, nitrile gloves, protecting overall	9	6800	9	550	190	9	ND (<2.1)	—
Purification laboratory										
Purification Part I	7	Fume hood/nitrile gloves, protecting overall	139	<360	464 ^c	0.05 ^e	0.05 ^e	139	ND (<0.28)	0.2 ^e
Purification Part II	8	Fume hood/nitrile gloves, protecting overall	154	<320				154	0.46	

Table 4. Continued

Work tasks	Location number in Fig. 1	Use of engineering controls/personal protective equipment	Respirable dust samples		Respirable EC samples		Microscopy samples		
			Air volume sampled ^a (l) ($\mu\text{g m}^{-3}$)	Mass concentration (l) ($\mu\text{g C m}^{-3}$)	Air volume sampled ^a (l) ($\mu\text{g C m}^{-3}$)	Mass concentration (l) ($\mu\text{g C m}^{-3}$)	Air volume sampled ^a (l) particles (l) particles ^b ($\# \text{ cm}^{-3}$)	CNT-containing particles (l) particles ^b ($\# \text{ cm}^{-3}$)	Calculated TWA ($\# \text{ cm}^{-3}$)
Functionalization Part I	9	Fume hood/nitrile gloves, protecting overall	29	<1700	29		29	1.0	
			55	<910	53		53	ND (<0.34)	
Functionalization Part II	10	Fume hood/nitrile gloves, protecting overall	81	<620	77		77	ND (<0.23)	
Grinding	11	Fume hood/nitrile gloves, protecting overall							

ND, not detected; —, not calculated.

^aThe used airflow was 2.2 l min⁻¹.

^bThe upper 95% one-sided confidence limits (95% CLs) of the number concentrations of CNT clusters in the air were calculated by assuming that the number of CNT-containing particles on the filter could be described using the Poisson distribution. The CL where the observed CNT cluster count was zero could be considered to be the LOD. The method for calculating the 95% CL was based on ISO 10312 (1995).

^cEquipped with filter Type P3.

^dInclude sieving, weighing, pouring, packaging, lathe machining, and reactor clean out Part I.

^eInclude all purification and functionalization parts and grinding.

particles occurred during sieving, mechanical work-up, weighing, pouring, and packaging. These were the work steps where MWCNT powder was openly handled. For example, MWCNT powder was poured from a container into the sieve or from a beaker into a small glass container with plastic lid. On the contrary only, a low concentration of EC and EC₃ could be measured during the work tasks in the purification laboratory ($0.05 \mu\text{g C m}^{-3}$).

The correlation between respirable EC and number concentration of CNT-containing particles had a Pearson correlation coefficient of 0.088 (Fig. 5). The correlation between respirable EC₃ and number concentration of CNT-containing particles had a Pearson correlation coefficient of 0.33 (Fig. 6).

DISCUSSION

This study investigated the feasibility and relative performance of three exposure metrics for exposure and emission to short CNTs ($<5 \mu\text{m}$) during arc discharge production, purification, and functionalization of MWCNTs. Parallel measurements of respirable dust,

respirable EC, and number concentration of CNT-containing particles were performed during both personal exposure measurements and emission measurements for each work task. Thus, we have valuable exposure data and can thereby assess the occupational exposure as well as evaluate the used exposure metrics. Based on the exposure data in this study, we consider the exposure metric number concentration of CNT-containing particles to be the best marker for occupational exposure to CNTs since it was the only exposure metric that was selective and could specifically quantify the exposure to CNTs.

Analysis of CNT-containing particles with SEM

To date, there is no standardized method for sampling of airborne CNT-containing particles. In this study, we collected MWCNTs on polycarbonate membrane filters in combination with SEM analysis, and particles with a size $>35 \text{ nm}$ were visible and thus counted. Similar methods were utilized by [Ogura et al. \(2011\)](#) and [Takaya et al. \(2012\)](#). But other studies have instead used methods developed for asbestos for

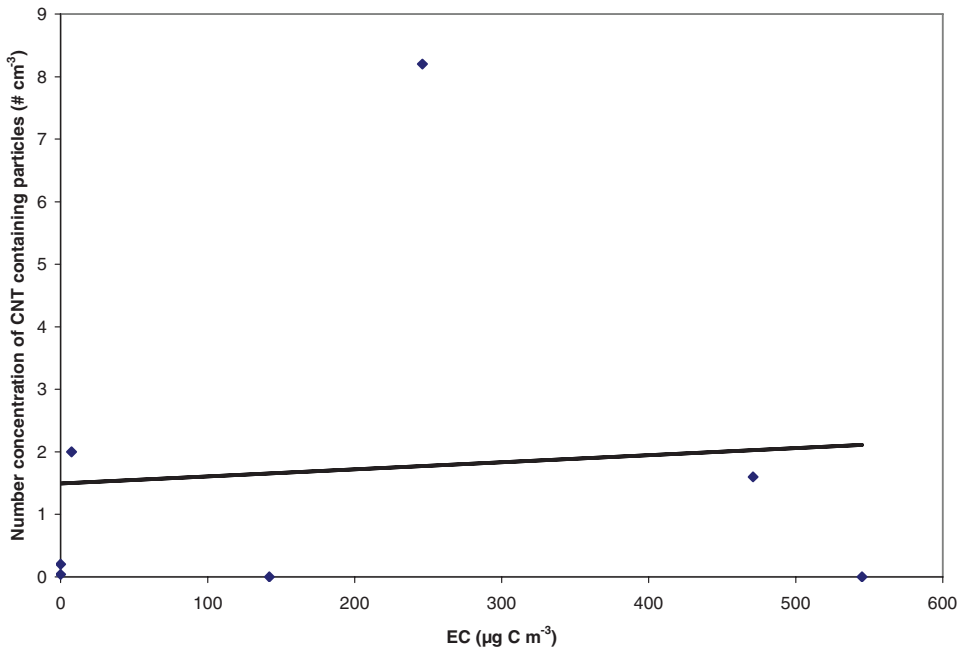

5 Correlation of number concentration of CNT-containing particles and EC (respirable fractions). The Pearson correlation coefficient was 0.088 with linear regression. Non-detect samples were given the value of half the LOD.

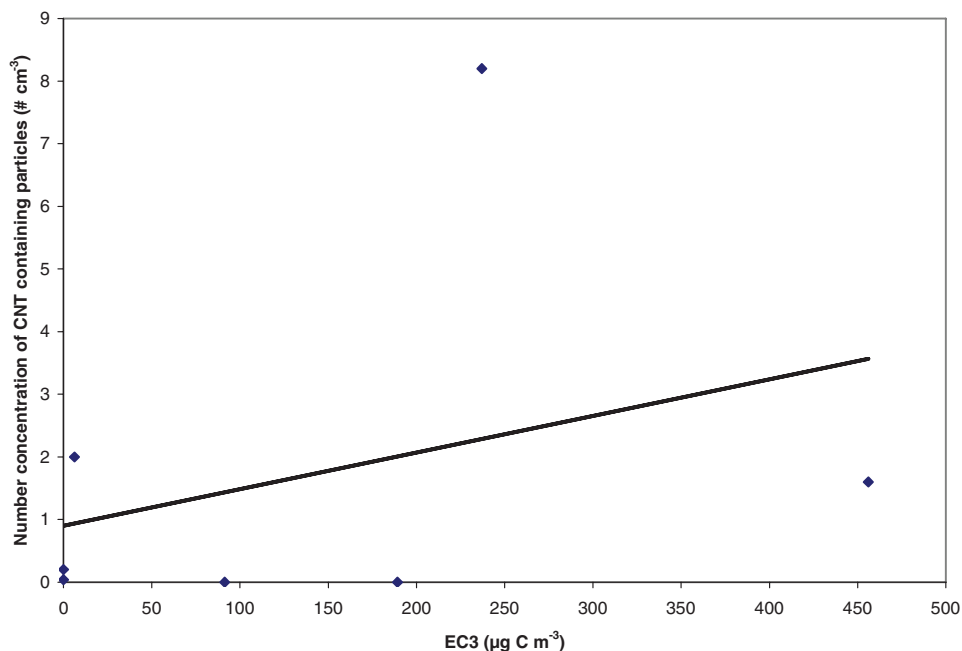

6 Correlation of number concentration of CNT-containing particles and EC3 (respirable fractions). The Pearson correlation coefficient was 0.33 with linear regression. Non-detect samples were given the value of half the LOD.

sampling of CNTs, where CNTs were collected on cellulose fibre filters in combination with TEM analysis (Bello *et al.*, 2008, 2009, 2010; Han *et al.*, 2008; Lee *et al.*, 2010; Dahm *et al.*, 2012). However, it is not only the sampling methods that contribute to difficulties to quantify CNT exposures, but it is also the absence of counting rules for CNTs at the electron microscopy analysis. So far, no standardized electron microscopy-based method for counting CNTs has been developed. Thus, to date, it is not clear how CNTs on filter samples should be counted (Brouwer *et al.*, 2012; Schulte *et al.*, 2012). A harmonization of the counting of CNTs in electron microscopy analysis will make it possible to compare exposure data for different workplace measurements.

According to the standard fibre counting criteria by the WHO (1986, 1997), a particle is defined as a fibre if it has a length of $>5 \mu\text{m}$, a width $<3 \mu\text{m}$, and $>3:1$ aspect ratio. These criteria are applied, for example in asbestos exposure quantification. Airborne CNTs appear to be heterogeneous in their shapes and structures as well as they more often are agglomerated

compared with asbestos. Since CNTs often not have the typical fibre dimensions, the standard fibre counting criteria cannot be applied (Schulte *et al.*, 2012). Our collected CNT-containing particles had often not the fibre dimensions and the length of the particles was commonly $<5 \mu\text{m}$. If we had followed the standard fibre counting criteria by WHO during the CNT counting, very few CNTs would then have been counted. Thus, the standard fibre counting criteria could not be followed, and instead, we chose to count every CNT-containing particle that was imaged with SEM. This is in accordance with how Dahm *et al.* (2012) counted CNTs who also found that their airborne CNT-containing particles were heterogeneous in their shapes and structures ranging from single CNTs to large agglomerates. Most of the counted CNT-containing particles in our study did not consist of individual tubes (79%). The CNTs were instead entangled or embedded in impurities and were thus larger in size compared with the individual tubes (Fig. 2b) but were nevertheless in the respirable size range. Thus, the detected airborne

CNT-containing particles could be classified into different particle types.

There is very limited knowledge of how the different types of CNT-containing particles will act after deposition in the lungs. For example, de-agglomeration of fibre bundles or fibres and carrier particles may take place (Wong *et al.*, 2009). Thus, we find it is important to report all detected airborne CNT-containing particles. With the SEM method, distinction was made between CNT structures and other types of particles, e.g. impurities and background particles. One limitation with SEM analysis is a potential high particle load on the filter if the exposure concentration is high when personal exposure measurements are conducted over extended time (for example full shift measurements). Overlap of deposited particles complicates the manual counting of CNT-containing particles with SEM. Furthermore, it was not straight forward to automatize the counting of particles with SEM due to interference of the pores in the membrane filters, and thereby the SEM analysis was time consuming and expensive. In one study, CNT clusters $> \sim 3$ and $0.3 \mu\text{m}$ were counted at the 1000 and 10 000 magnification, respectively (Ogura *et al.*, 2011). With our SEM method, we could identify and measure individual and small bundles of CNTs down to the nanometre size range (Fig. 2a,b). We also noted that particles with diameters $< 35 \text{ nm}$ were present in our samples. During the SEM analysis, it was possible to use higher magnification and thus, smaller particles down to $\sim 10 \text{ nm}$ could be identified and it could be investigated if these particles contained CNTs or not. However, this was only performed on a small number of particles with diameters $< 35 \text{ nm}$.

Toxicological effects of CNTs have mainly been discussed for CNTs with a length $10\text{--}20 \mu\text{m}$ due to frustrated phagocytosis (Brown *et al.*, 2007; Donaldson *et al.*, 2010; Murphy *et al.*, 2012). However, CNTs with $< 5 \mu\text{m}$ have also shown to have effects *in vivo* (Pauluhn, 2010). It is not clarified how small bundles of CNTs or CNT-containing particles as shown in Fig. 2b will act when deposited in the surfactant lining fluid in the lungs. For example, the worst-case scenario for shorter CNTs ($< 5 \mu\text{m}$) would be if the CNTs attached to particles dissolved and detached from the particles and became free individual CNTs inside cells in the respiratory tract. Shorter CNTs will not behave like longer CNTs ($> 14 \mu\text{m}$) *in vivo* and

cause frustrated phagocytosis. Shorter CNTs have in animal studies shown to cause adverse effects such as pulmonary inflammation and fibrosis (Mercer *et al.*, 2010, 2011; Pauluhn, 2010; Porter *et al.*, 2013). Based on the fact that longer CNTs could cause frustrated phagocytosis, the nanotechnology industry may design safer materials by using shorter CNTs to avoid critical human effects, and the production of CNTs might then change towards production of shorter CNTs. Thus, it is very important to know how to best measure occupational exposures and emissions of shorter CNTs.

Respirable dust

From the exposure data in Tables 2 and 4, it is obvious that respirable dust is not suitable as an exposure metric for CNT exposure. For the majority of the measurements of respirable dust, the mass concentrations were below the detection limit, while SEM analysis detected a significant number of airborne CNT-containing particles. Similar results have also been reported previously (Johnson *et al.*, 2010; Methner *et al.*, 2012). Also the opposite result was obtained when the respirable dust measurement indicated a high mass concentration during reactor clean out Part II, and the SEM analysis showed no exposure to airborne CNT-containing particles. Thus, the exposure metric respirable dust had low sensitivity and specificity to measure and quantify exposures to CNTs. With this method, no distinction could be made between CNT structures and other types of particles, e.g. impurities and background particles.

Elemental carbon

EC is a selective exposure metric for carbonaceous compounds including CNTs, amorphous carbon, graphite, and soot, but it does not specifically measure CNT exposure. NIOSH has recommended that occupational exposures to all types of CNTs should be monitored by a mass-based airborne concentration until additional data are available to determine if other exposure metrics or techniques would be more effective in protecting workers health (NIOSH, 2010). Furthermore, exposure measurements of CNT exposure should according to NIOSH include measurements of EC and a recommended exposure limit of $1 \mu\text{g m}^{-3}$ has been proposed (NIOSH, 2013). From the parallel measurements in this study, it was shown

that EC does not correlate with the number concentration of CNT-containing particles (Fig. 5). The correlation between EC3 and number concentration of CNT-containing particles was higher but still low. A correlation between EC and number concentration of CNT structures counted by TEM was shown by Dahm *et al.* (2012). The correlation coefficient was reported to be 0.44, which corresponds to a R^2 of 0.19. This means that only 19% of the variability in the CNT exposure could be explained by the EC measurements. Also, some of the EC values in that study showed no or very low mass concentrations, while a significant number of CNT structures were counted by TEM analysis, thus indicating false negative values and that EC had low sensitivity for CNT exposures.

Furthermore, from the parallel personal exposure measurements of the workers in the purification laboratory, EC was not detected while a TWA of 0.04–0.1 CNT-containing particles cm^{-3} could be measured. Thus, it was clearly shown that also purification laboratory work with CNTs causes occupational exposure. We considered the exposure metric EC to be both too insensitive and unspecific to be used as a generic exposure metric for CNT exposures during arc discharge production. SEM analysis is time consuming, expensive, and not at all as commercially available as EC analysis, but it is very important that the analytical method used to quantify exposures to CNTs has high selectivity and sensitivity to CNTs.

In this study, the emission measurements were performed for work tasks handling carbonaceous material with different CNT content. If measurements were performed repeatedly for the same work task, it would probably give high correlation between CNT and EC given that the same type of CNT material was used. With material dependence, EC could be used as a proxy for CNTs for the specific work task if the correlation is known. However, the correlation between EC or EC3 and CNTs would differ significantly between different tasks due to variations in the CNT matrix composition. This assumption is based on a specific CNT material's ability to agglomerate as well as the purity of the material, and the correlation is expected to be better between the same manufacturer of MWCNT as opposed to a different manufacturer of MWCNT. Finally, it should be pointed out that manufacturing of CNTs with the arc discharge method may represent a worst case scenario as large amounts of non-CNT carbonaceous by-products

may be emitted, a substantial fraction of which is classified as EC with the thermal–optical method.

According to Ono-Ogasawara and Myojo (2013), EC3 (carbon mass oxidized at 920°C) could be a more selective exposure metric to CNT exposure than EC since the MWCNTs thereby could be separated from other carbonaceous substances with smaller geometrical dimensions that oxidize at lower temperatures in the EC method. From the parallel samples collected during reactor clean out Part II, no CNT structures were detected but the highest EC concentration was measured indicating release of other carbonaceous compounds than CNTs. EC analysis showed that the EC3 fraction of total EC was only 35% for this task, while it was up to 96% of total EC for work tasks where the emitted concentrations of CNTs were high. This indicates that oxidation of other carbonaceous compounds than CNTs preferentially occurs at lower temperatures. The correlation between EC3 and the number concentration of CNT-containing particles was low and only 6% of the variability in CNT exposure could be explained by the EC3 measure. Thus, our limited data do to some extent support the results presented by Ono-Ogasawara and Myojo (2013), but the explained part of the variability by the EC3 measurement is still very small.

The EC method does not distinguish between CNT structures and other types of carbonaceous particles, e.g. impurities and background particles. One limitation with the EC measurements was that we used 37-mm filters instead of 25-mm filters, which caused a slightly higher LOD. Another limitation in the EC sampling in our study was the lack of sampling outdoors to be able to assess the extent of anthropogenic sources of infiltrated EC contamination inside the facility. However, in the nearby rural background site 65 km to the east of the location of the company, the 1-week average concentration of EC was $0.32 \pm 0.03 \mu\text{g C m}^{-3}$ at the time of the exposure measurements. Further, three out of the eight analysed EC samples were below the detection limit; this suggests that infiltrated EC from ambient air was only very weakly affecting our results.

Another more general problem with EC analysis is that there are several different EC protocols available (with large variations in oxidation temperatures used, oxidation time at each step, different strategies to correct for positive or negative artefacts from organic

carbon etc.). So, there is a need for a standardized and specific 'CNT protocol' for EC analysis of CNT material to be set up as soon as possible. A harmonization of the EC analysis of CNTs will make it possible to compare exposure data for different workplace measurements. Based on our data, it is clear that the CNT-specific protocol needs to include temperatures with prolonged oxidation time up to at least 900°C, as CNTs may require higher oxidation temperatures compared with most other carbonaceous materials.

Occupational exposure to CNTs

The personal exposure measurements were performed during both production and laboratory work. The highest exposure was measured during production work with sieving, mechanical work-up, pouring, weighing, and packaging of CNT powder in the sieving laboratory; unfortunately, we could not with the used sampling strategy estimate the different emissions for these different tasks because they were integrated with each other and the sampling time would otherwise have been too short. However, Worker A in the production laboratory and sieving laboratory used a negative-pressure half-face respirator with particulate filter of Class P3 at the different work tasks, but Worker A did not use the half-face respirator between the work tasks. For practical reasons, the personal exposure measurements were performed outside the half-face respirator. However, Workers B and C in the purification laboratory were also exposed to CNTs and they did not use any respiratory personal protective equipment (PPE). Their exposures were 6–50 times lower in comparison with the worker in production.

The proposed benchmark exposure limits for fibrous nanomaterials with high aspect ratios ($>3:1$ and length $>5 \mu\text{m}$) of $0.01 \text{ fibre cm}^{-3}$ (BSI, 2007; IFA, 2009) cannot be used for CNT exposures as described here due to the heterogeneous structures of CNTs, their agglomeration and CNTs not having the typical fibre dimensions (aspect ratio). Thus, it is difficult to compare our number concentrations from the SEM analysis with other studies due to differences in how the CNTs were counted. For example, two previous studies followed the WHO counting criteria for asbestos in combination with analysis with phase contrast microscopy (NIOSH Method 7400, 1994) with a visible LOD $>250 \text{ nm}$ and reported no or few CNT fibres (Bello *et al.*, 2009; Lee *et al.*, 2010). In the study by

Dahm *et al.* (2012), a method for asbestos was used for quantification (NIOSH Method 7402) but the method was modified and the steps required for asbestos identification were eliminated. The personal exposure measurements ($N = 7$) in that study performed at different work tasks during CNT production and laboratory work, ranged from 0.003 to $0.4 \text{ CNT structures cm}^{-3}$ and $\text{ND}-1.6 \text{ CNT structures cm}^{-3}$, respectively (Dahm *et al.*, 2012). Furthermore, one of our two personal exposure measurements exceeded the proposed recommended exposure limit of EC ($1 \mu\text{g C m}^{-3}$). Dahm *et al.* (2012) also measured levels of EC ($0.68\text{--}5.25 \mu\text{g C m}^{-3}$) at different work tasks during CNT production exceeding the recommended exposure limit for EC. Thus, the measured number and EC concentrations in our study are in the same order as reported by Dahm *et al.* (2012). The exposure sources differ in the studies. We measured exposure to arc-discharge-produced MWCNTs while Dahm *et al.* (2012) measured exposure to both SWCNTs and MWCNTs mainly from the CVD method. Both types of production methods produce CNTs that can have a high content of carbonaceous impurities, 40–45% (Popov 2004; Köhler *et al.*, 2008). Thus, production of MWCNTs with arc discharge and CVD seems to cause occupational exposure within the same range, but of course, other parameters in the workplaces, e.g. protective measures also have influence on the exposure. During the arc discharge production in the studied facility, no metal catalysts were used. Thus, surrogates for CNT exposure based on metal content cannot be used in this case. Metal surrogates such as Fe and Ni have been reported for CNT production with CVD and laser ablation (Maynard *et al.*, 2004).

In this study, the measured personal respirable dust concentrations were up to almost $100 \mu\text{g m}^{-3}$. Thus, it is in the same concentration range as reported by Ma-Hock *et al.* (2009) to cause mild granulomatous inflammation in the lung and in lung-associated lymph nodes in rats. It is therefore possible that unprotected work during production could cause similar adverse health effects to the worker. However, the properties of the CNT materials differ, for example in terms of tube length and purity, and as previously discussed, total dust is not at all a specific exposure metric for CNTs.

In the fields of occupational hygiene, direct-reading instruments to measure, e.g. mass concentration or particle number concentration are often used to

monitor exposure. This type of direct-reading instrument is often pre-calibrated against a specific type of particles by the manufacturer and thus, the measured concentrations should only be used as indicative. To the Nanotracer monitor, we applied 0.51-m tubing and the measured average particle sizes ranged between ~50 and 65 nm. We calculated the diffusion losses in the tubing with the used flow rate of 0.24 l min^{-1} , and for 50-nm-sized particles, 99.8% of the sampled particles reached the instrument and the corresponding value for 100-nm-sized particles was 99.9%. Thus, diffusion losses in the tubing during the samplings were very low. As long as the particles are not too small in size (e.g. $<10 \text{ nm}$), the deposition in the tubing can be neglected in relation to the accuracy of the instrument (Asbach *et al.*, 2012). In this study, it was shown that the usefulness of the direct-reading instruments was limited because they were too unspecific to measure exposures to CNTs, which is in accordance with what Dahm *et al.* (2013) also reported. For CNT exposures, selective and sensitive methods must be used to quantify exposures. The results from more sophisticated stationary direct-reading instruments and the comparison of size distributions determined by these devices (for example an Aerodynamic Particle Sizer) and the size distribution of both CNT containing and 'total' concentration of particles detected by SEM will be presented elsewhere. A comparison between personal sampling (Nanotracer) and sampling in the emission zone (CPC) of particle number concentrations showed a correlation in the purification laboratory although that the measurement points had different distance to the emission source ($r = 0.84$). The particle number concentration data from the two direct-reading approaches in the production laboratory and sieving laboratory did not correlate that well, which might be due to that the worker was more mobile in his work than the workers in the purification laboratory ($r = 0.30$).

Clearly, a direct-reading instrument that shows a reasonable degree of specificity for CNTs would be highly desirable to use in the future, particularly in research-oriented emission studies of CNTs. This would complement the SEM analysis that is per default offline and has limited time resolution. Highly time-resolved instruments give strongly superior possibilities both to identify sources and effectively mitigate emissions.

Candidates to be investigated include filter-based direct-reading instruments such as Aethalometers or Particle Soot Absorption Photometers that measure black carbon based on the wavelength-dependent light-absorption properties and more sophisticated direct-reading aerosol mass spectrometers (Onasch *et al.*, 2012, Nilsson *et al.*, 2013)

It is noteworthy that some non-authority institutions have proposed mass-based occupational exposure limits for CNTs, for example NIOSH and Bayer, but up to now, no country has adopted occupational exposure limits for CNTs. This study gives support to the complexity authorities are facing when discussing occupational exposure limits for CNTs.

PPE and engineering controls

The used PPE and engineering controls in the facility can be seen in Table 4. The worker in the production laboratory and sieving laboratory used a half-face respirator with particulate filter of Grade P3 as PPE during the different work tasks. The workers in the purification laboratory did not use any respiratory protection at all. To protect the workers from dermal exposure to CNTs, protection gloves made of nitrile and laboratory coats were used. The handling of CNTs in the facility was open both during work in the production laboratory and sieving laboratory as well as in the purification laboratory. The open handling of CNT powder contributed to increased airborne exposure but also to dermal exposure due to surface contamination with dust on different surfaces in the workplace. For CNT exposures, the precautionary principle must be applied until the toxicological effects of CNT exposure have been evaluated. In practice, this means closed handling in combination with a high level of control measures and a high degree of use of PPE. Thus, the workers in the facility were assessed to have higher exposure than necessary due to lack in the PPE as well as in the engineering controls. Dry CNT powder should not be openly handled in the facility without any engineering controls, e.g. ventilated enclosures (Schulte *et al.*, 2012). During all open handling of CNTs in the facility, respiratory protection must be used. To protect the workers more efficiently, PPEs such as coveralls, hoods, and shoe protection were needed especially in the production laboratory to prevent dermal exposure and to inhibit the CNT dust to be spread in the workplace. Furthermore, the

used engineering controls were assessed to not be enough for controlling the CNT exposure. For example, the production laboratory was not located in a closed area since it was part of a larger room that was used for other purposes such as storing; see Fig. 1 for the layout of the facility. The production laboratory was connected via stairs to other rooms in the building without any airtight sluice. This means that airborne CNT-containing particles could be present in other rooms in the building and thereby cause exposure to other unprotected workers. Also, the office used by production workers was located next to the sieving laboratory, and since the same shoes were used in both the production laboratory and sieving laboratory as in the office, there might be a high risk that the floor in the office was contaminated with CNT dust.

CONCLUSIONS

The occupational exposures as well as the emissions during specific work tasks, performed in a small-scale factory producing MWCNTs by arc discharge, have been quantified. The highest exposure to CNTs occurred during work with producing CNTs. The highest measured concentration in the emission zone, 11 CNT-containing particles cm^{-3} , was measured at open handling of CNT powder during work tasks as sieving, mechanical work-up, pouring, weighing, and packaging. To be able to quantify exposures and emissions of shorter as well as longer CNTs, a selective and sensitive method is needed. To date, only filter-based methods in combination with SEM/TEM analysis can be selective and sensitive enough. Furthermore, a standardized protocol for counting criteria of CNTs must be set up as soon as possible. A harmonization of the electron microscopy analysis will make it possible to compare exposure data for different workplace measurements.

SUPPLEMENTARY DATA

Supplementary data can be found at <http://annhyg.oxfordjournals.org/>.

FUNDING

Swedish Research Council for Health, Working Life and Welfare (FAS/FORTE Grant number 2009-1291); Nanometer Structure Consortium at Lund University.

ACKNOWLEDGEMENTS

The authors thank Karl Espen Yttri at the Norwegian Institute for Air Research (NILU). The study was carried out within the competence centres METALUND and nmC@LU at Lund University.

REFERENCES

- Asbach C, Kaminski H, Von Barany D *et al.* (2012) Comparability of portable nanoparticle exposure monitors. *Ann Occup Hyg*; 56: 606–21.
- Barkauskas J, Stankeviciene J, Selskis A. (2010) A novel purification method of carbon nanotubes by high-temperature treatment with tetrachloromethane. *Separ Purif Technol*; 71: 331–6.
- Bello D, Hart AJ, Ahn K *et al.* (2008) Particle exposure levels during CVD growth and subsequent handling of vertically-aligned carbon nanotube films. *Carbon*; 46: 974–7.
- Bello D, Wardle BL, Yamamoto N *et al.* (2009) Exposure to nanoscale particles and fibers during machining of hybrid advanced composites containing carbon nanotubes. *J Nanopart Res*; 11: 231–49.
- Bello D, Wardle BL, Zhang J *et al.* (2010) Characterization of exposures to nanoscale particles and fibers during solid core drilling of hybrid carbon nanotube advanced composites. *Int J Occup Environ Health*; 16: 434–50.
- Birch ME, Cary RA. (1996) Elemental carbon-based method for monitoring occupational exposures to particulate diesel exhaust. *Aerosol Sci Technol*; 25: 221–41.
- Brouwer D, Berges M, Virji MA *et al.* (2012) Harmonization of measurement strategies for exposure to manufactured nano-objects; report of a workshop. *Ann Occup Hyg*; 56: 1–9.
- Brown DM, Kinloch IA, Bangert U *et al.* (2007) An in vitro study of the potential of carbon nanotubes and nanofibres to induce inflammatory mediators and frustrated phagocytosis. *Carbon*; 45: 1743–56.
- BSI. (2007) Nanotechnologies – part 2: guide to safe handling and disposal of manufactured nanomaterials, London: British Standards. PD 6699-2:2007.
- Dahm MM, Evans DE, Schubauer-Berigan MK *et al.* (2012) Occupational exposure assessment in carbon nanotube and nanofiber primary and secondary manufacturers. *Ann Occup Hyg*; 56: 542–56.
- Dahm MM, Evans DE, Schubauer-Berigan MK *et al.* (2013) Occupational exposure assessment in carbon nanotube and nanofiber primary and secondary manufacturers: mobile direct-reading sampling. *Ann Occup Hyg*; 57: 328–44.
- Donaldson K, Murphy FA, Duffin R *et al.* (2010) Asbestos, carbon nanotubes and the pleural mesothelium: a review of the hypothesis regarding the role of long fibre retention in the parietal pleura, inflammation and mesothelioma. *Part Fibre Toxicol*; 7: 5.
- Donaldson K, Murphy F, Schinwald A *et al.* (2011) Review: identifying the pulmonary hazard of high aspect ratio nanoparticles to enable their safety-by-design. *Nanomedicine*; 6: 143–56.

- Donaldson K, Poland CA. (2009) Nanotoxicology: new insights into nanotubes. *Nat Nanotechnol*; 4: 708–10.
- Gasser M, Wick P, Clift MJD *et al.* (2012) Pulmonary surfactant coating of multi-walled carbon nanotubes (MWCNTs) influences their oxidative and pro-inflammatory potential in vitro. *Part Fibre Toxicol*; 9: 17
- Gustavsson P, Hedmer M, Rissler J. (2011) Carbon nanotubes – exposure, toxicology and protective measures in the work environment. Report 2011:1. Stockholm, Sweden: Swedish Work Environment Authority.
- Han JH, Lee EJ, Lee JH *et al.* (2008) Monitoring multiwalled carbon nanotube exposure in carbon nanotube research facility. *Inhal Toxicol*; 20: 741–9.
- Hedmer M, Käredal M, Gustavsson P *et al.* (2013) The Nordic Expert Group for criteria documentation of health risks from chemicals. 148. Carbon nanotubes. *Arbete och Hälsa*; 47(5): 1-238. ISBN 978-91-85971-46-6, University of Gothenburg, Sweden. Available at: <http://hdl.handle.net/2077/34499>. Accessed 28 November 2013.
- Hsieh SF, Bello D, Schmidt DF *et al.* (2012) Biological oxidative damage by carbon nanotubes: fingerprint or footprint? *Nanotoxicology*; 6: 61–76.
- Hussain F, Hojjati M, Okamoto M *et al.* (2006) Polymer-matrix nanocomposites, processing, manufacturing, and application. *J Compos Mater*; 40: 1511–75.
- IFA. Criteria for assessment of the effectiveness of protective measures. Available at: <http://www.dguv.de/ifa/Fachinfos/Nanopartikel-am-Arbeitsplatz/Beurteilung-von-Schutzma%C3%9Fnahmen/index-2.jsp>. Accessed 12 June 2013.
- Iijima S. (1991) Helical microtubules of graphitic carbon. *Nature*; 354: 56–8.
- ISO 10312. (1995) Ambient air—determination of asbestos fibres—direct transfer transmission electron microscopy method.
- Johnson DR, Methner MM, Kennedy AJ *et al.* (2010) Potential for occupational exposure to engineered carbon-based nanomaterials in environmental laboratory studies. *Environ Health Perspect*; 118: 49–54.
- Köhler AR, Som C, Helland A *et al.* (2008) Studying the potential release of carbon nanotubes through the application life cycle. *J Clean Prod*; 16: 927–37.
- Lee JH, Lee SB, Bae GN *et al.* (2010) Exposure assessment of carbon nanotube manufacturing workplaces. *Inhal Toxicol*; 22: 369–81.
- Ma-Hock L, Treumann S, Strauss V *et al.* (2009) Inhalation toxicity of multiwall carbon nanotubes in rats exposed for 3 months. *Toxicol Sci*; 112: 468–81.
- Maynard AD, Baron PA, Foley M *et al.* (2004) Exposure to carbon nanotube material: aerosol release during the handling of unrefined single walled carbon nanotube. *J Toxicol Environ Health A*; 67: 87–107.
- McIntyre RA. (2012) Common nano-materials and their use in real world applications. *Sci Prog*; 95 (Pt. 1): 1–22.
- Mercer RR, Hubbs AF, Scabilloni JF *et al.* (2010) Distribution and persistence of pleural penetrations by multi-walled carbon nanotubes. *Part Fibre Toxicol*; 7: 28.
- Mercer RR, Hubbs AF, Scabilloni JF *et al.* (2011) Pulmonary fibrotic response to aspiration of multi-walled carbon nanotubes. *Part Fibre Toxicol*; 8: 21.
- Methner M, Crawford C, Geraci C. (2012) Evaluation of the potential airborne release of carbon nanofibers during the preparation, grinding, and cutting of epoxy-based nanocomposite material. *J Occup Environ Hyg*; 9: 308–18.
- Murphy FA, Schinwald A, Poland CA *et al.* (2012) The mechanism of pleural inflammation by long carbon nanotubes: interaction of long fibres with macrophages stimulates them to amplify pro-inflammatory responses in mesothelial cells. *Part Fibre Toxicol*; 9: 8.
- Nagai H, Okazaki Y, Chew SH *et al.* (2011) Diameter and rigidity of multiwalled carbon nanotubes are critical factors in mesothelial injury and carcinogenesis. *Proc Natl Acad Sci USA*; 108: E1330–8.
- Nakanishi J, editor. (2011) Risk assessment of manufactured nanomaterials: carbon nanotubes (CNT). NEDO project (P06041) Research and development of nanoparticle characterization methods. Final report issued on 17 August 2011.
- Nilsson PT, Isaxon C, Eriksson AC *et al.* (2013) Manufactured nano objects emitted during maintenance of common particle generators. *J Nanopart Res*; 15: 2052.
- NIOSH. (2010) Draft current intelligence bulletin occupational exposure to carbon nanotubes and nanofibers. Cincinnati, OH: US Department of Health and Human Services, Centers for Disease Control, National Institute for Occupational safety and Health. DHHS (NIOSH), NIOSH Docket Number: NIOSH 161-A. Available at <http://www.cdc.gov/niosh/docket/review/docket161A/>. Accessed 21 June 2011.
- NIOSH. (2013) Occupational exposure to carbon nanotubes and nanofibers. Current intelligence bulletin 65, publication no. 2013-145. Available at <http://www.cdc.gov/niosh/docs/2013-145/pdfs/2013-145.pdf>. Accessed 24 May 2013.
- Ogura I, Sakurai H, Mizuno K *et al.* (2011) Release potential of single-wall carbon nanotubes produced by super-growth method during manufacturing and handling. *J Nanopart Res*; 13: 1265–80.
- OH Learning. (2010) W504 – fibre counting. Available at http://www.ohlearning.com/Files/Extracted_Files/38/W504coursematerial/JD33%20v1-0%2010Apr10%20W504%20Fibre%20counting.ppt#385,1,W504-fibre counting. Accessed 15 October 2013.
- Onasch TB, Trimborn A, Fortner EC *et al.* (2012) Soot particle aerosol mass spectrometer: development, validation, and initial application. *Aerosol Sci Technol*; 46: 804–17.
- Ono-Ogasawara M, Myojo T. (2013) Characteristics of multi-walled carbon nanotubes and background aerosols by carbon analysis; particle size and oxidation temperature. *Adv Powder Technol*; 24: 263–9.

- Palomäki J, Välimäki E, Sund J *et al.* (2011) Long, needle-like carbon nanotubes and asbestos activate the NLRP3 inflammasome through a similar mechanism. *ACS Nano*; 5: 6861–70.
- Pauluhn J. (2010) Subchronic 13-week inhalation exposure of rats to multiwalled carbon nanotubes: toxic effects are determined by density of agglomerate structures, not fibrillar structures. *Toxicol Sci*; 113: 226–42.
- Plata DL, Gschwend PM, Reddy CM. (2008) Industrially synthesized single-walled carbon nanotubes: compositional data for users, environmental risk assessments, and source apportionment. *Nanotechnology*; 19: 185706.
- Poland CA, Duffin R, Kinloch I *et al.* (2008) Carbon nanotubes introduced into the abdominal cavity of mice show asbestos-like pathogenicity in a pilot study. *Nature Nanotechnol*; 3: 423–28.
- Popov VN. (2004) Carbon nanotubes: properties and application. *Materials Sci Eng Rep*; 43: 61–102.
- Porter, DW, Hubbs AF, Chen BT *et al.* (2013) Acute pulmonary dose-responses to inhaled multi-walled carbon nanotubes. *Nanotoxicology*; 7: 1179–94.
- Ryman-Rasmussen JP, Tewksbury EW, Moss OR *et al.* (2009) Inhaled multiwalled carbon nanotubes potentiate airway fibrosis in murine allergic asthma. *Am J Respir Cell Mol Biol*; 40: 349–58.
- Schinwald A, Chernova T, Donaldson K. (2012a) Use of silver nanowires to determine thresholds for fibre length-dependent pulmonary inflammation and inhibition of macrophage migration in vitro. Part *Fibre Toxicol*; 9: 47.
- Schinwald A, Murphy FA, Prina-Mello A *et al.* (2012b) The threshold length for fiber-induced acute pleural inflammation: shedding light on the early events in asbestos-induced mesothelioma. *Toxicol Sci*; 128: 461–70.
- Schneider T *et al.* (2007) Evaluation and control of occupational health risks from nanoparticles. *TemaNord 2007:581*. Copenhagen: Nordic Council of Ministers.
- Schulte PA, Kuempel ED, Zumwalde RD *et al.* (2012) Focused actions to protect carbon nanotube workers. *Am J Industr Med*; 55: 395–411.
- Takagi A, Hirose A, Nishimura T *et al.* (2008) Induction of mesothelioma in p53+/- mouse by intraperitoneal application of multi-wall carbon nanotube. *J Toxicol Sci*; 33: 105–16.
- Takaya M, Ono-Ogasawara M, Shinohara Y *et al.* (2012) Evaluation of exposure risk in the weaving process of MWCNT-coated yarn with real-time particle concentration measurements and characterization of dust particles. *Ind Health*; 50: 147–55.
- Tan CW, Tan KH, Ong YT *et al.* (2012) Carbon nanotubes applications: solar and fuel cells, hydrogen storage, lithium batteries, supercapacitors, nanocomposites, gas, pathogens, dyes, heavy metals and pesticides, Chapter 1. In Lichtfouse E, Schwarzbauer J, Robert D, editors. *Environmental chemistry for a sustainable world: Volume 1: Nanotechnology and health risk*. Netherlands: Springer. pp. 3–46.
- Thomas T, Bahadori T, Savage N *et al.* (2009) Moving toward exposure and risk evaluation of nanomaterials: challenges and future directions. *Wiley Interdiscip Rev Nanomed Nanotechnol*; 1: 426–33.
- WHO. (1986) *Asbestos and other natural mineral fibres*. Environmental health criteria, no. 53. Geneva: World Health Organization.
- WHO. (1997) *Determination of airborne fibre number concentrations: a recommended method, by phase-contrast optical microscopy (membrane filter method)*. Geneva: World Health Organization. ISBN 92 4 154496 1.
- Wohlleben W, Brill S, Meier MW *et al.* (2011) On the lifecycle of nanocomposites: comparing released fragments and their in-vivo hazards from three release mechanisms and four nanocomposites. *Small*; 7: 2384–95.
- Wong BA, Nash DG, Moss OR. (2009) Generation of nanoparticle agglomerates and their dispersion in lung serum simulant or water. *J Phys Conf Ser*; 151:012036. doi:10.1088/1742-6596/151/1/012036

Article V

Effects on Heart Rate Variability by Artificially Generated Indoor Nano-sized Particles in a Chamber Study

To be published in **Atmospheric Environment** 2013 (Ref. No.: ATMENV-D-13-01515R1)

Inger Hagerman¹, Christina Isaxon², Anders Gudmundsson², Aneta Wierzbicka², Katrin Dierschke³, Margareta Berglund¹, Joakim Pagels², Jörn Nielsen³, Eva Assarsson³, Ulla BK Andersson³, Yiyi Xu³, Bo A.G. Jönsson³, Mats Bohgard²

¹Department of Cardiology, Karolinska Institute, Karolinska University Hospital, Huddinge, Sweden, ²Ergonomics and Aerosol Technology, Lund University, Sweden, ³Division of Occupational and Environmental Medicine, Lund University, Sweden

Corresponding author: Inger.hagerman@karolinska.se
Department of Cardiology, Karolinska University Hospital, Huddinge
M52, 141 Stockholm
Tel: +46858581749, mobile: +46706841163
Fax: +4685856710

1.1 Introduction

An increasing number of studies show correlation between chronic exposure to airborne particles and health problems, for instance from the cardiovascular system, by promoting inflammation and atherosclerosis (Ezzati et al., 2002; Brook et al., 2010; Nawrot et al., 2011; Weichenthal, 2012). Since humans, at least in the industrialized parts of the world, tend to spend more than 85% of their life indoors (Klepeis et al., 2001) particles in these environments are of special interest from a health perspective. As the development of new measurement instruments is progressing, the understanding for which particle properties affect our health is increasing, and more extensive studies of aerosols and their health influence are motivated and needed.

Particularly the health impact of airborne nano-sized particles with a dimension <100 nm is of increasing concern, not least as a consequence of the growing industry of engineered nano materials. However, humans are already today frequently exposed to high concentrations of nano-sized particles, in general indoor environments as well as in workplaces. Several indoor activities generate particles in the nano-size range. Recent studies indicate that about 60% of integrated daily residential exposure to nano-size particles by number can be attributed to indoor sources (Bekö et al., 2013; Bhangar et al., 2011; Mullen et al., 2011; Wallace and Ott, 2011). Burning candles have previously been identified as a significant source of nano-sized particles (Stabile et al, 2012; Hussein et al., 2006; Pagels et al., 2009) and other examples of nano-size particle generating sources are heat related activities such as cooking, frying, toasting and laser printing but also cleaning products and furniture polish containing terpenes, which in presence of ozone form particles (Brook et al., 2010).

The mechanisms behind the health impact of fine and nano-sized particles are not fully understood, although some studies in recent years provide a basis for better theoretical

understanding of exposure, uptake and kinetics (Brown et al., 2000; Koch and Stöber, 2001; Kreyling et al., 2002; Oberdorster et al., 2004). Most of today's knowledge about airborne particle's health impact is the result of epidemiological studies based on measurements of outdoor particles. Sun et al. (2010) pointed out the need to acquire knowledge about the specific combination of airborne particles which can be blamed for health concerns. A need for toxicological studies exists, as well as means to assess health effects of exposure to indoor particles in humans (Morawska et al., 2013).

Heart rate variability (HRV) is, since long a well-recognized, noninvasive, independent method, for cardiovascular risk prediction in high prevalent groups (Malik, 1996). Influence of the sympathetic and parasympathetic branches of autonomic nervous system regulates heart rate and its variability. The major part of this variability is constituted by alterations in respiratory mediated influence on the parasympathetic load. Further, a link between inflammatory mediators and autonomic cardiac control has been shown (Czura and Tracey 2005; Sloan et al., 2007; Luttmann-Gibson 2010) and an association between low grade inflammation and cardiovascular disease has been reported (Ridker and Morrow, 2003; Celik et al., 2011). In this work, a methodology has been developed with the purpose of exploring the effects on heart rate variability in healthy humans exposed to indoor generated candle particles and particles from terpene-ozone reactions.

1.1.1 Aim

The aim of this study was to design a feasible chamber study with laboratory generated common indoor air particles and to evaluate the impact of these nano-sized particles on noninvasive markers of cardiovascular reactivity such as heart rate and its variability. The

hypothesis (H0) was defined as no observed changes in the high frequency band (HF) of HRV during exposure and if changes proven, resulting in rejection of H0.

1.1.2 Methods

The experimental chamber

The exposure chamber is a 22 m³ room where all interior surfaces (except for a window 0.8 m²) are covered with a layer of stainless steel, see Figure 1. No air can enter or leave the chamber except through a well-controlled ventilation system. The chamber is supplied with air through a separate conditioning system by which air flow, temperature and relative humidity can be controlled and adjusted. The air passes through an activated carbon filter and an Ultra-Low Penetration Air (ULPA) filter before entering the chamber at roof level. An over-pressure in the chamber is typically maintained at 10 Pa or just below, to avoid undesired penetration of particles from the surrounding laboratory. The chamber can be used for human exposure as well as for source characterization and aerosol transformation studies and is previously described in detail (Isaxon et al., 2013).

1.1.3 Particle generation system

The generation system for candle smoke consisted of a glass and stainless steel chamber with a total volume of 1.3 m³. An inlet for filtered and pressurized air was placed in the bottom of the chamber to provide a steady controlled flow through the generation volume. Ten blue paraffin/stearine candles of a common commercial brand were lit inside the generation volume. A mobile fan was used to make the flames flicker and hence produce soot particles in a way similar to the air streams which are created when there is movement in the vicinity of a candle in a normal indoor setting. The generation chamber was protected from contamination

from the surrounding air by a hatch in front of the chamber opening. This hatch was kept closed at all times except for when the generation was initiated (Pagels et al., 2009).

Terpene vapor was generated continuously by passing pure nitrogen through a glass bottle of commercial essential oil (lemon oil, *oleum citri*, Interlam AB), consisting of 60-95 % *d*-limonene. Ozone was generated by a spark discharge generator (Ozone Technology AB, model AM 3000-2) using filtered dry air, and was added to the ventilation air flow before this flow entered the exposure chamber, just downstream the inlet for addition of terpene vapours. The terpene vapour reacts with ozone in the gas phase before entering the exposure chamber which initiates a cascade of chemical reactions generating reaction products distributed between the gas and particle phase.

During the exposures, particle mass concentration was monitored with a Tapered Element Oscillating Microbalance (TEOM, Rupprecht & Patashnic Co Inc.) and particle number concentration and size distribution by a Scanning Mobility Particle Sizer system (consisting of a CPC 3010, TSI Inc and a long column Hauke DMA), all on-line techniques with a time-resolution of minutes. The candle smoke particle chemical composition was characterized by PIXE (Particle Induced X-ray Emission Analysis) and OC/EC (Organic Carbon/Elemental Carbon) analysis. In the terpene-ozone case, Gas Chromatography – Mass Spectrometry (GC-MS) was used to determine the terpene concentration, aerosol mass spectrometry (AMS) to assess chemical composition of particles, while the ozone concentration was measured with a spectrophotometric ozone monitor (Thermo model 92). The temperature, relative humidity, carbon dioxide levels and (in the case of terpene particles) ozone levels were monitored

during the exposures to secure steady state conditions. The methodology and technical details of the particle generation and chamber air monitoring is given by Isaxon et al. (2013).

1.1.4 Subjects and study design

The study group consisted of 22 healthy adult female test subjects (mean age 32, 19-62) who on different occasions were exposed to: candle particles; particles generated by terpene-ozone reactions or filtered air. At each session a group of 3 test subjects spent 4 hours together in the chamber. Thirteen test subjects (out of 22) were exposed to all three exposure conditions, while remaining 9 to two conditions, i.e. to particle laden air (either candle particles or particles generated by terpene-ozone reactions) and to filtered air. The exposures were conducted according to a double blind protocol, hence the particle levels were blinded both to the volunteers and to the medical investigators. Prior to the commencement of the study, test subjects underwent a physical examination including heart and lung status and skin prick test to assess the atopic status. Medical and work history was registered, from personal communication between medical staff and test persons, according to a structured protocol. They were all found to be healthy without medication.

The study design is illustrated in Figure 2. Venous blood samples and nasal lavage during the experiments were secured for a separate study. Registration of heart rate variability started around 8:00 in the morning and ended around 12:00. Three HRV recordings were made inside the chamber. The 1st recording was made as a baseline, before exposure commencement i.e. without particle exposure at filtered air condition, where the following two recordings were taken in equal time intervals during the exposure. In the study a 4th recording was also made although later it was excluded from the analysis since the conditions in the chamber were

significantly changed i.e. it was made after particle evacuation from the chamber and additionally the noise from the express fan (evacuating the particles) was likely to cause disturbance in these measurements. In the chamber the volunteers were placed in a comfortable reclining chair with feet support which allowed a half-lying position with feet elevated. After a steady state period of 10 minutes, time series of heart beats were collected during 10 minutes (sampling frequency 200 Hz) at 3 occasions evenly distributed in time. During the steady state period and the measurement period the lights were shut down and no talking or moving was allowed, as all stimuli that increases sympathetic nervous outflow may affect HRV. Based on previous experience (Hagerman 1996) a steady state period of 10 minutes were considered sufficient to exclude influence of external stimuli. All recordings were manually edited by an experienced and blinded member of the staff, excluding artifacts ($\pm 25\%$ of median heartbeat interval in ms) and ectopic beats ($\pm 10\%$ of median heartbeat interval in ms). HRV was analyzed for various spectral components using the Power Lab system (AD Instruments Pty, Ltd. U-PL/QS-05XB, 2006). Times series of minimum 600 heart beats allowed analysis of total variability (TP), power in high frequency band (HF) (0.15-0.4 Hz) and low frequency (LF) band (0.04-0.15 Hz). The autonomic balance expressed by LF/HF was computed.

1.1.5 Statistical analysis

As the major part of HRV consists of alterations in respiratory dependent HF band, this parameter was used as primary endpoint for analysis, but low frequency (LF) was also studied as well as the LF/HF ratio. Percentage changes from baseline were calculated for each individual and each exposure scenario to reduce the influence of inter-individual variation for the data from HF and LF/HF. The changes in the selected outcome measures at candle

particles or particles generated by terpene-ozone reactions vs. changes at zero exposure were analyzed with repeated-measures analysis of variance using a linear model type of the generalized estimating equation in SPSS 20.0 (SPSS Inc., Chicago, IL, USA). Subject identification, the three exposure scenarios, and the time point of measurements were used to indicate the repeated measurements. All the results were adjusted by age. The 4th recordings (after exposure values) were excluded from analysis since they were performed when the chamber had been evacuated and filled with clean air, which otherwise might have diluted the results from the provocations. Two subjects were excluded from the HF analysis since they were absent from particle free air exposure. Another one subject was excluded from LF/HF analysis since she showed an extreme low LF at baseline. In the analysis comparing only candle and particles generated by terpene-ozone reactions, nine subjects were excluded since they were absent from either of these two exposure scenarios. Statistical significance refers to $p < 0.05$ (two-tailed).

1.1.6 Ethics

The study was approved by the Ethical Committee, Lund University, Dnr 160/207

1.1.7 Results

The typical particle size distributions during exposure are shown in Figure 3. Mean particle concentrations in number and mass as well as exposure characteristics as air temperature, relative humidity, carbon dioxide and ozone concentrations are given in Table 1. The concentrations were similar of what can be observed in normal indoor settings when for instance having a dinner (candle smoke particles) (Wierzbicka, 2008; Stabile et al., 2012; Bekö et al., 2013) or cleaning (particles generated from terpene-ozone reactions) (Wierzbicka,

2008). The candle combustion resulted in bi-modal size distribution (Figure 3) consisting of: an ultrafine mode of particles (count mean diameter of 23 ± 2 nm and mass mean diameter of 59 ± 4 nm) and a soot mode of particles (count mean diameter of 270 ± 14 nm, mass mean diameter of 477 ± 23 nm). Bi-modal size distribution agrees well with previously reported characteristics of particles due to candle burning (Stabile et al., 2012; Pagels et al., 2009; Wallace, 2006) The particles generated by terpene-ozone reactions displayed single mode size distribution (Figure 3) with a count mean diameter of 98 ± 7 nm and a mass mean diameter of 258 ± 17 nm. Both aerosol sources hence result in particles of the fine and ultrafine type, which have the potential to be inhaled and deposited in the alveolar tract of the respiratory system. As previously reported (Isaxon et al., 2013) the candle particles consisted of 68% elemental carbon (soot), 8% nitrates, 7% of organic carbon, 7% potassium, 6% sodium and minor traces of metals (Cu, Sn) (mass percentages). The particles from the terpene-ozone reactions consisted of 64% carbon, 28% oxygen and 8% hydrogen (mass percentages). The ozone levels in the exposure chamber were low (10 ± 4) ppb compared to average indoor ozone concentrations, which are 28-60 ppb (Rohr et al 2003), and which can exceed 120 ppb during summertime in urban areas (Singer et al 2006).

Original data from HF and LF are presented in Table 2 and 3. We found a mild but significant effect of age, indicating ten years older is related to 8.3% decrement of HF ($p=0.04$). Exposure to the particles from burning candle increased HF by 22.3% ($p=0.01$, CI 5.6, 39.1) compared to zero exposure and adjustment for age (Table 4), while exposure to particles generated by terpene-ozone reactions tended to decrease HF by 7.2% ($p=0.41$, CI -24.5, 10.0) with adjustment of age (Table 4). The LF/HF tended to decrease during exposure for burning of candle and increase during exposure to particles generated by terpene-ozone reactions (Table 4). The changes in HF during candle exposure and particles generated by terpene-

ozone reactions exposure were in the different directions, and the difference was 28.9% and was significant ($p=0.02$, CI 5.4, 52.5.) (Table 5). Heart rate (beats/min) was unchanged in all groups during all experimental settings (data not shown).

1.1.8 Discussion

Firstly, the aim of this study was to establish a model with chamber exposures together with online registration of time series of ECG in order to explore the effects of common nano-sized indoor particles on HRV in healthy individuals. The two aerosols used contain nano-sized particles and are common in indoor air, thus ethically justified for human exposure and in realistic concentration levels high enough for studies of physiological responses and at the same time avoiding unrealistic and unethical exposures. The experimental chamber design and model system for particle generation used in this study have been evaluated by Isaxon et al. (2013) who demonstrated that aerosols in home environments could be reproduced in this chamber experimental setting with a particle concentration, size distribution and composition comparable to those in field studies. We found that time series of ECG signals could easily be collected with sufficient sampling frequency, from the inside of the chamber, on line from 3 individuals at the same time.

This study shows that candle particle exposure increase HF power ($p=0.01$) and tends to decrease LF/HF indicating a shift in the autonomic balance to a more parasympathetic tone. For particles from terpene-ozone reactions the HF was not changed ($p>0.4$), but tended to shift LF/HF to a less parasympathetic tone. The hypothesis H_0 that the chosen provocations not would affect HF could therefore be rejected. It can also be concluded that the difference of change in HF for candle exposure compared to exposure of particles generated by terpene-

ozone reactions was significant ($p=0.02$). It can also be concluded that with high significance that candle particles did not decrease the variability in HF spectral band.

HF is reported to reflect the influence of respiration and vagal tone in the autonomic modulation of heart rate variability (Malik 1996; Hagerman et al., 1996; Yasuma and Hayano 2004; Grossman and Taylor, 2006). The autonomic nervous system has properties to detect inflammatory stimuli. Afferent signals via nervous vagus results in efferent nervous vagus signaling. This cholinergic anti-inflammatory pathway is reported to modulate cytokine production (Czura and Tracey, 2005; Sloan et al., 2007; Huston and Tracey, 2011) and such a mechanism could contribute to changes in HRV during states of inflammation. Various tests for inflammatory parameters were taken during and after the exposure and will be reported in a separate study. Previous field studies of HRV and exposure to fine airborne particles mostly demonstrate reduced HRV and HF. Increased HF associated with increase in inflammatory blood parameters during exposure were presented by Riediker et al (Riediker 2004). The results of Wu et al (Wu 2010) were more consistent with previous results with decreased HRV and HF during traffic-related PM exposure although there were a heterogeneity on the individual level. This illustrates the difficulties in HRV measurements and interpretation, with a large interindividual variability and underlines the need of structured experiments during steady state conditions. Nevertheless, the association between inflammation and effects on vagal tone and possible importance in cardiovascular diseases needs to be studied in different settings.

In several field studies in homes, candles have been identified as sources of ultra-fine particles (Hussein et al., 2006; Matson 2004; Wierzbicka 2008). During normal steady burn, in

principle all soot formed in the flame can be oxidized, resulting in very low elementary carbon (EC) emissions. Elemental carbon concentrations emitted from candles can be very high as shown in various experiments by Pagels et al. (2009), and a potential health hazard related to candle burning is the occurrence and release of metal additives from the wick and color pigments

It is likely that particles from indoor sources can cause health effects (Schneider et al., 2003, Eriksson and Stenberg, 2006). For example, Li et al., (2003) demonstrated that ultrafine particulate pollutants induced oxidative stress on a cellular level with mitochondrial damage. In this study with adult and healthy female volunteers direct health effects are unlikely. Heart rate variability was chosen as being potential pre-cursors of health effects at exposures of particles from different sources which emit particles of different characteristics. In a review on relations between particles and health effects (Schneider et al., 2003) it was pinpointed that in order to draw conclusions about potential health-effects of indoor particles, several properties of the particles has to be known. These were particle concentrations (number, surface area and mass), chemical composition, solubility, hygroscopicity and biological constituents. In our study, characteristics of the two types of particles used for exposures i.e. from candle burning and from terpene-ozone reactions, varied considerably. The levels of particles were generated to reflect real concentrations encountered in indoor environments and the differences are seen in: mass concentrations ($200 \mu\text{g}/\text{m}^3$ versus $80 \mu\text{g}/\text{m}^3$ for candles and terpenes/ozone, respectively), number concentration ($8 \cdot 10^5 \text{ \#/cm}^3$ versus $3 \cdot 10^4 \text{ \#/cm}^3$, for candles and terpenes/ozone, respectively), size distribution (bi-modal versus single mode size distribution for candles and terpenes/ozone, respectively) and chemical composition (elemental carbon dominated candle particles [68% by mass] versus solely soluble organics in terpenes/ozone particles). All these listed characteristics are determinant for the fraction that

deposits in respiratory tract and causes given effect. The candle particles consisted of a mixture of elemental carbon (68% by mass) and water soluble salts (such as phosphates and alkali nitrates), while the secondary organic aerosol particles from terpene-ozone reaction products consisted of highly oxidised water soluble organics and no elemental carbon at all. Controlled human exposure to ozone is reported to increase markers of inflammation and markers that affect autonomic control of heart rate (Devlin et al., 2012). In our experiments efforts were made to keep the ozone concentration (see Table 1) as low as possible to avoid potential adverse health effects. As compared with Devlin study of 0.3 ppm ozone concentration our levels were 30 times lower.

A limitation of our study is the lack of controlled respiration but all tests were performed during carefully observed steady state conditions at the same time point of the day and with no intake of coffee, tea or other substances, factors that could have an impact on HRV. Heart rate response to a change in parasympathetic efferent activity is extremely rapid, occurring on a beat-to-beat basis while the change due to sympathetic outflow is a slower process (Hagerman et al., 1996). This, together with other influences on HRV for example hormones, pre- and afterload of the heart, vascular endothelial function results in a signal which is composed of several oscillators with overlapping time scales. The HRV signal is therefore complex and sensitive to both internal and external influences. This could contribute to the large inter-individual variability in heart rate variability measurements and in part explain the heterogeneity and conflicting results between studies of HRV and air pollution (Mills et al., 2011). As the major part of HRV is constituted by respiratory mediated alterations in the HF band and the results of our study, where different kinds of nano-sized particles seem to affect HF in different ways support the very idea that the airway is important for modulation of the autonomic nervous system. The effects on HRV would then depend on to what extent and

where particles are deposited together with their biochemical properties mediating inflammatory responses. Further studies on the effects of various particles on HRV are therefore needed.

1.1.9 Conclusions

Exposure to nano-sized particles of burning candles and terpene-ozone reactions seem to have an impact on heart rate variability in healthy individuals, although significant statistical correlations only were demonstrated in part. The highly significant difference in HF between the two aerosols with significantly different characteristics in: particle mass and number concentration, size distribution and chemical composition strengthens these results. Future work will include particles of various characteristics in order to get information on how particle characteristics may influence HRV and studies of different cohorts with increased risk for cardiovascular health problems. The design of the chamber study together with the HRV method may be used to get information on physiological response of exposure to particles of different concentration, sizes and characteristics which may contribute to the understanding of mechanisms behind health effects of particle exposures.

1.1.10 Acknowledgments

This study was financed by the Swedish Research Council FORMAS and performed within the framework of Metalund, the Centre for Medicine and Technology for Working Life and Society, a competence centre at Lund University, Sweden, supported by FORTE, the Swedish Research Council for Health, Working Life and Welfare .

References

- Bhangar S., Mullen N.A., Hering S.V., Kreisberg N.M. and Nazaroff W.W., 2011. Ultrafine particle concentrations and exposures in seven residences in northern California, *Indoor Air*, 21, 132-144.
- Bekö G., Weschler C., Wierzbicka A., Karotki D. G., Toftum J, Loft S., Clausen G., 2013. Ultrafine particles: Exposure and source apportionment in 56 Danish homes. *Environmental Science and technology*, 47, 10240–10248
- Brook R.D., Rajagopalan S., Pope III, A.C., Brook J.R., Bhatnagar A., et al., 2010. Particulate Matter Air Pollution and Cardiovascular Disease. Un Update to the Scientific Statement from the American Heart Association. *Circulation* 121, 2331-2378.
- Brown D.M., Stone V., Findlay P., MacNee W., Donaldson K., 2000. Increased inflammation and intracellular calcium caused by ultrafine carbon black is independent of transition metals or other soluble components. *Occupational and Environmental Medicine* 57, 685-691.
- Celik T., Yuksel U.C., Demirkol S., Bugan B., Lyisol A., Kabul H.K., Kilic S., Fici F., Yaman H., 2011. Relationship between increased systemic inflammation and impaired aortic elasticity in young patients with prehypertension. *Blood Press Monit.* 16(2), 55-61.
- Czura C.J., Traycey K.J., 2005. Autonomic neural regulation of immunity. *Journal of Internal Medicine*, 257, 156-166.
- Devlin R.B., Duncan K.E., Jardim M., Schmitt M.T., Rappold A.G., Diaz-Sanchez, D., 2012. Controlled Exposure of Healthy Young Volunteers to Ozone Causes Cardiovascular Effects. *Circulation*, 126, 104-111.
- Eriksson N.M., Stenberg B.G., 2006. Baseline prevalence of symptoms related to indoor environment. *Scand J Public Health* 34(4), 387-396.
- Ezzati M., Lopez A.D., Rodgers A., Vander Hoorn S., Murray C.J.L., 2002. Selected major risk factors and global and regional burden of disease. *Lancet* 360, 1347-1360.
- Grossman P., Taylor E.W., 2006. Toward understanding of respiratory sinus arrhythmia: relations to cardiac vagal tone; evolution and bio behavioural functions. *Biological Psychology*, 74, 263-285.
- Hagerman I., Berglund M., Lorin M., Nowak J., Sylvén C., 1996. Chaos-related deterministic regulation of heart rate variability in time-and frequency domains: effects of autonomic blockade and exercise. *Cardiovasc Res*, 31(3), 410-418.
- Huston J.M., Tracey K.J., 2011. The pulse of inflammation: heart rate variability, the cholinergic anti-inflammatory pathway and implications for therapy. *J Intern Med*. 269,45-53.
- Hussein T., Glytsos K., Ondracek J., Dohanyosova P., Zdimal V., Hameri K., 2006. Particle size characterization and emission rates during indoor activities in a house. *Atmospheric Environment*, 40, 4285-4307.
- Isaxon C., Dierschke K., Pagels J., Wierzbicka A., Gudmundsson A., Löndahl J., Hagerman I., Berglund M., Assarsson E., Andersson U.B., Jönsson B.A.G., Nojgaard J.K., Eriksson A., Nielsen J., Bohgard M., 2013. Realistic indoor nano-aerosols for a human exposure facility. *Journal of Aerosol Science*, 60, 55-66.
- Klepeis N.E., Nelson W.C., Ott W.R., Robinson J.P., Tsang A.M., Switzer P., Behar J.V., Hern S.C., Engelmann W.H., 2001. The National Human Activity Pattern Survey (NHAPS): a resource for assessing exposure to environmental pollutants. *J Expo Anal Environ Epidemiol*, May-Jun; 11(3), 231-252.

- Koch W., Stöber W., 2001. A Simple Pulmonary Retention Model for Inhaled Particles Accounting for Dissolution and Macrophage-mediated Removal. *Inhalation Toxicology* 13, 129.
- Kreyling W.G., Semmler M., Erbe F., Mayer P., Takenaka S., Schulz H., Oberdorster G., Ziesenis A., 2002. Translocation of ultrafine insoluble iridium particles from lung epithelium to extrapulmonary organs is size dependent but very low. *Journal of Toxicology and Environmental Health-Part A* 65, 1513-1530.
- Li N., Sioutas C., Cho A., Schmitz D., Misra C., Sempf J., Wang M.Y., Oberley T., Froines J., Nel A., 2003. Ultrafine particulate pollutants induce oxidative stress and mitochondrial damage. *Environmental Health Perspectives* 111, 455-460.
- Luttman-Gibson H, Suh HH, Coull BA, Dockery DW, Samat SE, Schwartz J, Stone PH, Gold D., 2010. Systemic inflammation, heart rate variability and air pollution in a cohort of senior adults. *Occup Environ Med* 67, 625-630.
- Malik M., 1996. Heart Rate Variability. Standards of Measurement, Physiological Interpretation and Clinical Use. Task Force of the European Society of Cardiology and the North American Society of Pacing and Electrophysiology. *Circulation* 93, 1043-1065.
- Matson U., 2004. Ultrafine Particles in Indoor Air. Doctoral thesis, Chalmers University of Technology, Sweden.
- Mills N.L., Finlayson A.E., Gonzalez M.C., Törnqvist H., Barath S., Vink E., Goudie C., Langrish J.P. et al., 2011. Diesel exhaust inhalation does not affect heart rhythm or heart rate variability. *Heart* 97, 544-550.
- Morawska, L., Afshari, A., Bae, G.N., Buonanno, G., Chao, C.Y.H., Hänninen, O., Hofmann, W., Isaxon, C., Jayaratne, E.R., Pasanen, P., Salthammer, T., Waring, M., Wierzbicka, A., 2013. Indoor Aerosols: From Personal Exposure to Risk Assessment. *Indoor Air*, 23(6), 462-487,
- Mullen, N.A., Liu, C., Zhang, Y., Wang, S. and Nazaroff, W.W., 2011. Ultrafine particle concentrations and exposures in four high-rise Beijing apartments, *Atmospheric Environment*, 45, 7574-7582.
- Nawrot T.S., Perez L., Künzli N., Munters E., Nemery B., 2011. Public health importance of triggers of myocardial infarction: a comparative risk assessment. *The Lancet* 377(9767), 732-740.
- Oberdorster G., Sharp Z., Atudorei V., Elder A., Gelein R., Kreyling W., Cox C., 2004. Translocation of inhaled ultrafine particles to the brain. *Inhalation Toxicology* 16, 437-445.
- Pagels J., Wierzbicka, A., Nilsson E., Isaxon C., Dahl A., Gudmundsson A., Swietlicki E., Bohgard M., 2009. Chemical Composition and Mass Emission Factors of Candle Smoke Particles; *Aerosol Science* 40, 191-208.
- Ridker P.M., Morrow D.A., 2003. C-reactive protein, inflammation and coronary risk. *Cardiol Clin*, 21(3), 315-325.
- Rohr A. C., Weschler C. J., Koutrakis P., Spengler J.D., 2003. Generation and quantification of Ultrafine Particles through Terpene/Ozone Reaction in a Chamber setting. *Aerosol Science and Technology* 37:65-78.
- Schneider T., Sundell J., Bischof W., Bohgard M., Cherie J.W., Clausen P.A., Dreborg S., Kildesø J., Kaergaard S.K., Løvik M., Pasanen P., Skyberg K., 2003. EUROPART. Airborne particles in the indoor environment. A European interdisciplinary review of scientific evidence on associations between exposure to particles in buildings and health effects. *Indoor Air* 13(1), 38-48.
- Singer B. C., Coleman B. K., Destailhats H., Hodgson A. T., Lunden M. M., Weschler C. J., Nazaroff W. W., 2006. Indoor Secondary Pollutants from Cleaning Product and Air

- Freshener use in the presence of Ozone. *Atmospheric Environment* Vol 40, 35:6696-6710.
- Sloan R.P., McCreath H., Tracey K.J., Sidney S., Liu K., Seeman T., 2007. RR interval variability is inversely related to inflammatory markers: The CARDIA study. *Mol Med*, 13(3-4), 78-184.
- Stabile L.; Fuoco F.C.; Buonanno G., 2012. Characteristics of particles and black carbon emitted by combustion of incenses, candles and anti-mosquito products. *Building and Environment*. 56, 184-191.
- Sun Q., Honh X. and Wold L.E., 2010. Cardiovascular effects of ambient particulate air pollution exposure. *Circulation* 121, 2755-65.
- Wallace, L. and Ott W., 2011 Personal exposure to ultrafine particles, *Journal of Exposure Science and Environmental Epidemiology*. 21, 20-30.
- Wallace L. 2006. Indoor sources of ultrafine and accumulation mode particles: Size distributions, size-resolved concentrations, and source strengths. *Aerosol Science and Technology*. 40, 348-360.
- Weichenthal S., 2012. Selected physiological effects of ultrafine particles in acute cardiovascular morbidity. *Environmental Research* 115, 26-36.
- Wierzbicka A., 2008. What are the characteristics of airborne particles that we are exposed to? – Focus on Indoor Environments and Emissions from Biomass Fires District Heating, Doctoral thesis, Lund University. ISBN 978-91-628-7443-8; LUTMDN/TMAT – 1019 – SE, EAT 2008; ISSN 1650 – 9773 Publication 30. KFS AB, Lund
- Yasuma F., Hayano J., 2004. Respiratory sinus arrhythmia: why does the heartbeat synchronize with respiratory rhythm? *Chest* 125(2), 683-90.

Figures

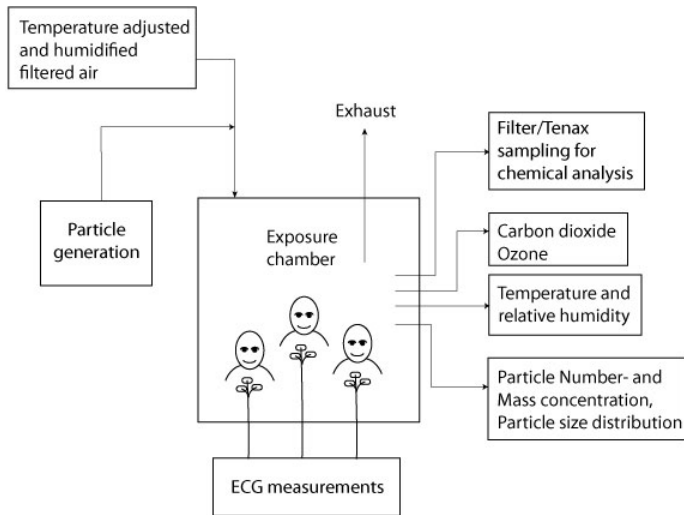

Figure 1. The experimental set-up for the chamber exposure studies

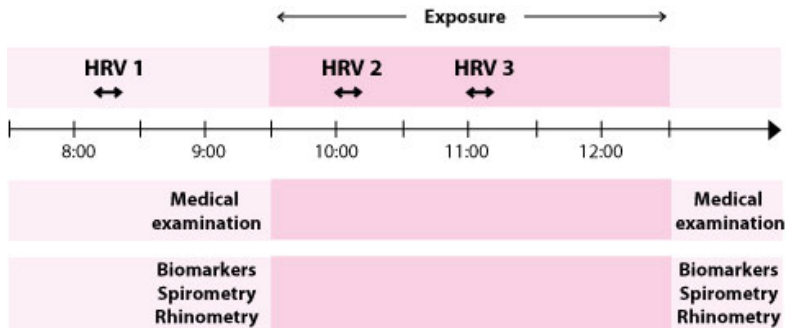

Figure 2. The experimental study design

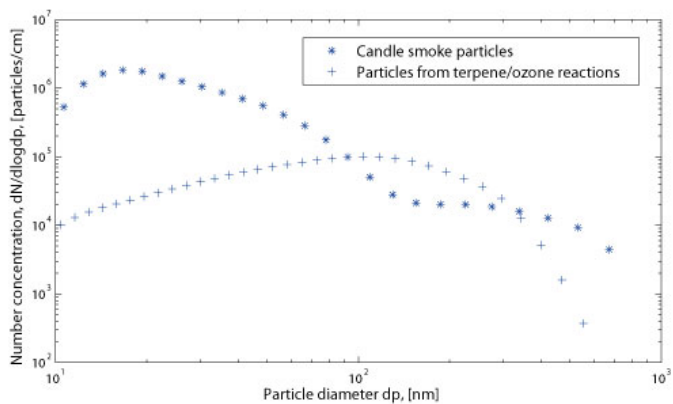

Figure 3. Typical size distributions from candle smoke exposure and from exposure for particles generated by terpene-ozone reactions.

Tables

Table 1. Exposure conditions of candle and terpene/ozone experiments, respectively

		Mean exposure ± Std	Median exposure	Min exposure	Max exposure
Number concentration (#/cm ³)	Candle	8·10 ⁵ ± 2·10 ⁵	9·10 ⁵	4.9·10 ⁵	9.1·10 ⁵
	Terpene	3·10 ⁴ ± 4·10 ³	3·10 ⁴	2.3·10 ⁴	3.3·10 ⁴
Mass Concentration (µg/m ³)	Candle	200 ± 30	200	170	240
	Terpene	80 ± 10	80	60	90
CO ₂ (ppm)	Candle	930 ± 60	920	780	1100
	Terpene	770 ± 50	760	650	970
RH (%)	Candle	33 ± 1.6	33	31	35
	Terpene	33 ± 1.5	32	31	35
Temperature (°C)	Candle	23 ± 0.6	23	22	24
	Terpene	23 ± 0.6	23	22	24
O ₃ (ppb)	Terpene	10 ± 4	7.5	7	18

Table 2. Recorded values from measurements of power in high frequency band (HF) of HRV during different exposures. Index 1 refers to before exposure, 2 refers to 30 minutes of exposure and 3 refers to 90 minutes of exposure.

Subject	Zero exposure			Candle particles			Terpene-ozone particles		
	Z ₁	Z ₂	Z ₃	C ₁	C ₂	C ₃	T ₁	T ₂	T ₃
1	611.6	1285.2	605.2	572.1	112.9	694.2	811.4	1509.0	1245.4
2	80.5	120.8	225.1	47.5	60.4	194.2	147.4	230.4	248.3
3	183.9	135.9	89.0	384.1	651.6	315.5			
4	177.1	291.4	180.4	150.5	239.9	106.6	267.7	269.3	305.6
5	631.0	621.5	737.7	420.5	1038.4	702.6			
6	1298.7	915.7	1097.3	1153.2	1288.6	730.1	1300.2	1584.6	2070.6
7	560.0	687.1	404.2	565.5	1277.1	197.9	751.8	267.4	142.4
8	221.9	199.1	175.2	342.1	285.9	485.1			
9	51.3	88.8	98.2	87.5	105.2	184.9	121.4	105.6	61.2

10	477.9	395.3	273.8	482.7	392.8	424.7	216.3	178.0	109.9
11	600.1	410.5	712.8	408.7	723.1	542.8			
12	264.4	154.5	163.2	189.1	368.0	449.9	477.3	451.5	330.8
13	150.7	150.2	179.5	178.0	89.2	221.8	558.6	316.6	446.1
14	1076.4	1236.0	1361.0	737.1	848.3	1226.4	1205.0	759.8	912.8
15	362.5	607.9	208.5	242.3	499.6	357.1	313.3	241.0	321.2
16				212.1	207.9	174.7	328.1	270.1	262.6
17	1384.3	1155.5	877.4	515.6	1068.6	553.4	1023.6	753.0	1159.2
18	1494.4	1511.3	836.6	1291.0	1815.5	1373.9			
19	1070.3	758.0	698.8				798.4	549.4	1326.3
20	2076.9	1793.0	1759.2				1694.5	2360.7	1691.2
21							945.2	625.8	767.8
22	381.1	733.9	764.2				307.9	231.5	209.8

Table 3. Recorded values from measurements of power in low frequency band (LF) of HRV during different exposures. Index 1 refers to before exposure, 2 refers to 30 minutes of exposure and 3 refers to 90 minutes of exposure.

Subject	Zero exposure			Candle particles			Terpene-ozone particles		
	Z ₁	Z ₂	Z ₃	C ₁	C ₂	C ₃	T ₁	T ₂	T ₃
1	604.4	725.6	426.6	609.1	224.5	764.7	507.0	649.8	651.0
2	204.8	229.4	289.5	88.9	102.9	431.7	138.8	395.0	273.9
3	274.5	184.1	82.4	230.5	276.1	191.7			
4	183.8	238.1	230.3	292.0	435.8	87.9	264.0	388.1	315.4
5	268.3	266.9	374.9	280.4	245.1	304.4			
6	586.3	442.0	324.1	652.6	682.3	649.4	506.6	483.5	441.9
7	323.2	463.5	362.3	393.1	474.4	447.0	409.1	390.3	452.3
8	65.7	136.2	71.7	45.3	336.2	394.4			

9	139.1	146.6	314.5	118.4	133.0	198.5	194.7	164.9	127.2
10	267.4	318.2	398.7	554.8	38.9	369.4	276.7	234.1	317.1
11	388.1	210.9	669.5	204.2	525.4	686.1			
12	330.3	276.5	133.5	214.2	440.4	439.8	386.5	468.5	596.0
13	176.5	351.6	353.8	394.9	135.7	212.4	459.6	187.6	268.1
14	269.7	388.3	614.2	322.0	499.1	468.0	310.7	306.1	427.4
15	224.2	331.4	201.9	614.5	357.5	295.7	260.2	233.0	231.2
16				288.1	119.8	96.2	192.3	112.2	178.8
17	461.5	327.6	262.6	822.6	459.5	349.0	164.4	219.4	214.5
18	426.5	522.5	739.9	292.7	486.3	623.1			
19	668.2	408.3	456.3				401.2	221.1	239.2
20	735.4	605.8	551.0				657.6	671.5	781.8
21							919.4	738.1	1025.5
22	155.0	412.9	218.5				174.6	159.9	439.8

Table 4. Percentage changes in the High Frequency (HF)^a and the Low Frequency/High Frequency (HF/LF)^b ratio values at particle exposures compared to zero exposure.

Exposure		% changes compared to base-line (mean)	% changes compared to zero exposure (mean)	% changes compared to zero exposure (95% CI)	P values (compared to zero exposure)
Zero exposure	HF	5.7	--	--	--
	HF/LF	9.8			
Candle	HF	28.0	22.3	(5.6, 39.1)	0.01
	HF/LF	-1.0	-10.8	(-31.2, 9.5)	0.30
Terpene+ozone	HF	-1.5	-7.2	(-24.5, 10.0)	0.41
	HF/LF	32.1	22.2	(-7.8, 52.3)	0.15

^a Statistic is based on 20 subjects and with adjustment for age.

^b Statistic is based on 19 subjects and with adjustment for age.

Table 5 Percentage changes in High Frequency (HF) values^a

Exposure	Percentage changes compare to base-line (mean)	Difference of percentage changes (mean)	Difference of percentage changes (95% CI)	P value
Candle	25.2	--	--	0.02
Terpene+ozone	-3.8	-28.9	(-52.5, 5.4)	

^a Statistic is based on 13 subjects and with adjustment for age.

	4		9		2		8	
1		7						
9	8				6			4
4	3			9				
2				5				9
				1			2	8
8			3				9	2
						5		1
	9		5		4		3	

College level

		7	5					4	
4						3			
		8						3	
8	3			7	1				6
					4				
1					3	6		5	4
		2						4	
				8					5
			9					1	2

Candidate level

		4			5	2		8
					1		9	4
	1							
	5			6		1		
	4						2	
		9		3			8	
							3	
7	2		5					
8		1	9			4		

PhD level

		7						
		2			6	8		
9				4	8			
5			3		9		2	
2								1
	9		8		5			4
			1	6				3
		1	5			7		
							5	

Professor level

