



# LUND UNIVERSITY

## Moisture in Self-levelling Flooring Compounds. Part I. Water Vapour Diffusion Coefficients

Anderberg, Anders; Wadsö, Lars

*Published in:*  
Nordic Concrete Research

2004

[Link to publication](#)

*Citation for published version (APA):*

Anderberg, A., & Wadsö, L. (2004). Moisture in Self-levelling Flooring Compounds. Part I. Water Vapour Diffusion Coefficients. *Nordic Concrete Research, Publication 32(2/2004)*, 3-15.

*Total number of authors:*  
2

### General rights

Unless other specific re-use rights are stated the following general rights apply:  
Copyright and moral rights for the publications made accessible in the public portal are retained by the authors and/or other copyright owners and it is a condition of accessing publications that users recognise and abide by the legal requirements associated with these rights.

- Users may download and print one copy of any publication from the public portal for the purpose of private study or research.
- You may not further distribute the material or use it for any profit-making activity or commercial gain
- You may freely distribute the URL identifying the publication in the public portal

Read more about Creative commons licenses: <https://creativecommons.org/licenses/>

### Take down policy

If you believe that this document breaches copyright please contact us providing details, and we will remove access to the work immediately and investigate your claim.

LUND UNIVERSITY

PO Box 117  
221 00 Lund  
+46 46-222 00 00

## Moisture in Self-levelling Flooring Compounds. Part I. Water Vapour Diffusion Coefficients



Anders Anderberg  
M.Sc., Dr.-student  
Div. Building Materials, Lund University  
P.O. Box 118, 221 00 Lund, Sweden  
E-mail: anders.anderberg@byggtek.lth.se

Lars Wadsö  
Dr., Senior researcher  
Div. Building Materials, Lund University  
P.O. Box 118, 221 00 Lund, Sweden  
E-mail: lars.wadso@byggtek.lth.se



### ABSTRACT

Diffusion coefficients of three self-levelling flooring compounds (SLC) and water vapour resistance of a primer have been measured with the cup method. The results show that the diffusion coefficient is dependent not only on the vapour content (relative humidity), but also on the absolute moisture content, i.e., there is a hysteresis effect on moisture transport. At RH lower than approximately 90 %, SLC have higher diffusion coefficients than a standard concrete (w/c 0.7 OPC), but the opposite is true at higher RH. This can be explained by the fact that SLC have different pore structure than concrete. The latter may also be an effect of the high amount of polymer in SLC that form a film throughout the material and thereby limits capillary moisture transport.

**Key words:** moisture transport, water vapour, self-levelling flooring compound, cup method, diffusion coefficient.

### 1. INTRODUCTION

During the last decades there has been an increasing interest in the possible connections between indoor air quality and health, and it has been found that dampness is a risk factor for health effects in the airways, as well as tiredness and headache [1]. This seems to be true irrespectively of whether the dampness is measured as condensation on windowpanes, water damage or smell/odour. However, the connection between dampness and health effects is not known. Two discussed possibilities are emissions from degraded building materials and emissions from microbiological growth. Both chemical degradation processes and microbiological growth increase with increasing moisture content (or relative humidity) as the molecular mobility of chemical reactants and microbial nutrients then increases [2].

Cementitious materials are often considered to contribute to healthy indoor environments, as they are stable inorganic materials. However, their very alkaline nature can give rise to problems as many other modern building materials, like adhesives, sealants, flooring materials and paints, are based on polymers, some of which are not stable under alkaline conditions. A common problem in Sweden is PVC flooring bonded to concrete floors with a water-based adhesive. As long as the concrete is dry the construction works well, but if the moisture level becomes too high the alkaline pore solution will come in contact with the adhesive, possibly degrading it by hydrolysis [3]. The degradation products are often strongly odorous alcohols like 2-ethylhexanol and butanol that diffuse through the PVC flooring into the indoor environment.

The above-mentioned problems can occur in older buildings if the moisture level in a concrete floor increases, for example because of leakage. It can also occur in new buildings if the concrete has not been dried enough before flooring materials are laid. Different solutions have been proposed to make it possible to build the above type of constructions without risk of degradation:

- The use of alkali resistant polymers in adhesives.
- The placement of a thin low-alkali flooring compound between the concrete and the adhesive.
- The use of self-desiccating concrete and flooring compounds.

These solutions and combinations of them have been tested with good results, both in laboratories and in buildings [3-6].

Self-levelling flooring compounds (SLC) are normally laid in 1-30 mm layers on concrete or other substrates to give a horizontal and smooth surface for flooring materials. When used on concrete they may also act as a barrier to alkalis between the concrete and the flooring, thus giving the flooring and adhesive a less aggressive environment. Usually a polymer primer is applied on the substrate before the SLC is laid. The primer gives a better and more uniform bonding between substrate and SLC, prevents air from the concrete to give rise to bubbles on the SLC surface and also prevents excessive amounts of water from the fresh SLC to be absorbed by the substrate.

This paper reports a study of water vapour diffusion coefficients of three commercial SLC measured with the cup method. Although several workers have measured diffusion coefficients of concrete and mortars, we know of only one previous study on a flooring compound (non self-levelling) [7]. The present study, together with measurements of sorption isotherms and scanning curves [8], can be used to predict the moisture state of flooring constructions. This is of interest, e.g., for prediction of:

- The long-term moisture state of the flooring adhesive.
- The distribution of the water from a water based adhesive applied on an SLC.
- The transport of hydroxide ions ( $\text{OH}^-$ ) from the usually more alkaline concrete to the flooring adhesive and other sensitive materials.

SLC consist of binder, filling materials, polymer and admixtures. The binders are normally a mixture of calcium aluminate cement (CAC), Portland cement (PC) and calcium sulphate in the forms of anhydrite and hemihydrate. Filling materials are sand and finely ground mineral materials like limestone. A polymer powder is added to improve abrasion resistance and the flexural and tensile strength of the otherwise brittle cement matrix. The polymer particles

coalesce and form a film [9] throughout the material that can be described as an interspersed secondary binder system [10]. The admixtures control for example setting time, curing time, flowing characteristics, air entrainment and separation. A more detailed description of SLC is given by Harbron [10].

The moisture state of a material can be presented in different ways. In this paper we have chosen to work with vapour content  $v$  (g vapour per  $m^3$  air). This can be seen as the vapour state in the pores of the material and is convenient as the same potential can also be used in the gas phase outside the material. The vapour content is the product of the relative humidity (expressed as a fraction) and the saturation vapour content, which can be found tabulated as a function of temperature.

Moisture can be transported by vapour diffusion, surface flow and capillary flow. Since it normally is of no interest to separate the effects of different kinds of transport processes, the total moisture flow is usually determined. The moisture transport properties of a material are then described with one coefficient, the diffusion coefficient  $D$ . For most materials the diffusion coefficient is a function of the vapour content (or, at isothermal conditions, the relative humidity, RH).

## 2. MATERIALS AND METHOD

### 2.1 Materials

The three tested commercial products were based on Portland cement, calcium aluminate cement, calcium sulphate and small amounts of silica fume. A typical composition of the mineral part of an SLC is shown in Table 1.

*Table 1 – Typical composition of the mineral part (excluding admixtures) of an SLC, partly adapted from [11].*

Portland cement	around 3 %
Calcium aluminate cement	around 17 %
Calcium sulphate	around 7 %
Limestone filler (calcite)	around 30 %
Sand (siliceous)	40-50 %
Silica fume	less than 3 %

The three tested products were:

- A. Normal SLC with water to binder ratio of about 1.0. This product is generally used in non-industrial constructions.
- B. Rapid-drying SLC, which is similar to the above product, but is used with lower water to binder ratio (about 0.7) to give the product a higher degree of self-desiccation. This product is mainly used in renovation as one can walk on it in 1-2 hours and apply final covering in 1 day.
- C. SLC for industrial floors, containing slag as a binder and a larger amount of polymer to increase the abrasion resistance [9]. The water to binder ratio is about 0.6. The final product allows medium heavy rolling equipment.

The products were mixed according to the manufacturers guidelines and left to hydrate, the first 24 hours in open air, approximately 20 °C and 50 % RH, and after that in sealed plastic bags. Measurements were made when the specimens were 2-6 months old, except the dried and resaturated specimens for hysteresis measurements that were 8-11 months old.

Influence of the amount of mixing water was tested in flooring compound A by using 10 % more and 20 % less mixing water than required by the manufacturer's guideline. The effects of hysteresis on the diffusion coefficient due to desorption or absorption was also tested by drying and wetting test specimens of flooring compound A before testing. These dried and wetted specimens had been used in the main measurement series. While still attached to the cups, they were either dried at 25 % RH and 30 °C, or resaturated with liquid deionised water.

The diffusion resistance of a primer was measured by applying it on test specimens of product A. The primer was a dispersion consisting of styrene acrylate in water. The fraction of styrene acrylate used in the dispersion depends on the substrate. In these tests the primer contained about 12 % styrene acrylate.

## 2.2 Cup method

The cup method was used to determine diffusion coefficients. In this method two different constant humidity levels are created at each side of a test specimen. Normally the specimen is placed as a lid on a cup containing a saturated salt-solution. The internal RH is controlled by the salt solution and the external RH is that of the room where the cup is placed. The mass flow rate is measured by weighing the cup regularly, thus registering the weight change of the cup.

Fick's law of diffusion is:

$$q = -D \frac{dv}{dx} \quad (1)$$

where  $q$  (g/(m<sup>2</sup>s)) is the moisture flow,  $D$  (m<sup>2</sup>/s) the diffusion coefficient and  $dv$  (g/m<sup>3</sup>) the difference in vapour content over the distance  $dx$  (m). An integrated form of Fick's law can then be used to calculate the diffusion coefficient:

$$q = \bar{D} \frac{v_2 - v_1}{L} \quad (2)$$

Here,  $\bar{D}$  (m<sup>2</sup>/s) is the average diffusion coefficient in the interval  $v_1$  to  $v_2$  and  $L$  (m) is the thickness of the specimen. A complication for a cup measurement is that the measured flow rate is not only a function of the diffusion resistance within the material, but also depends on external mass transfer resistances at both sides of the specimen,  $Z_i$  and  $Z_e$  (s/m). Inside the cup  $Z_i$  is normally equal to the diffusion resistance of the stagnant air in the gap between the salt solution and the specimen. Outside the cup, where there always are air movements,  $Z_e$  is a boundary layer mass transfer resistance. The total flow can thus be described as follows:

$$q = \frac{1}{L/\bar{D} + Z_i + Z_e} (v_2 - v_1) \quad (3)$$

The diffusion cups (Fig. 1) used in this study, were designed and previously used by Hedenblad [12]. The cups were made of polypropylene and the sealing was made with a polyurethane sealant (Marine Adhesive Sealant 5200, 3M, St Paul MI, USA). The tightness of the cups was validated with aluminium specimens. The leakage was 0.5 mg per day over a 300-day period with an internal RH of 100 % and an external RH of 55 % at 20 °C. This leakage corresponds to less than 1 % of the moisture flow in all present measurements.

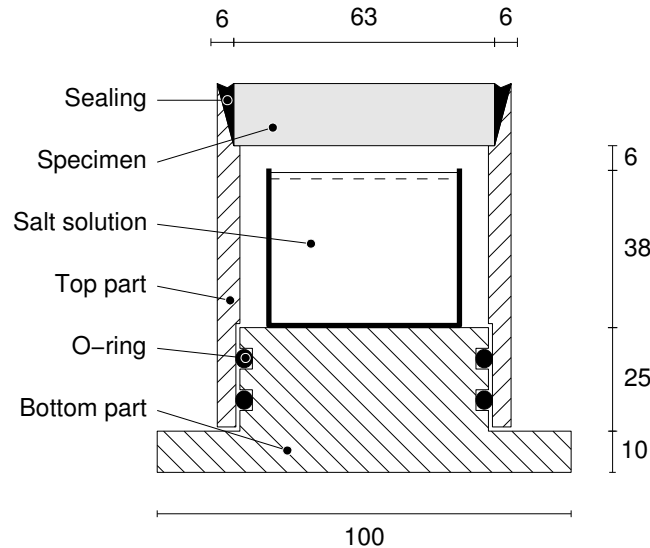

Figure 1– Schematic picture of the cup used.

The experiments were carried out with focus on higher RH, as this is the most interesting area related to indoor environment. The diffusion coefficients were mainly determined at  $20 \pm 1$  °C with an outer climate of  $55 \pm 2$  % RH. The RH inside the cups were as follows [13]:

75.5 % (NaCl)	85.1 % (KCl)	94.6 % (KNO <sub>3</sub> )
97.6 % (K <sub>2</sub> SO <sub>4</sub> )	100 % (H <sub>2</sub> O)	

Tests were also performed at  $5 \pm 1$  °C in a climate box. The outer climate had an RH of 63.5 %, (NaBr) and the RH inside the cups were as follows [13]:

75.6 % (NaCl)	87.7 % (KCl)	96.3 % (KNO <sub>3</sub> )
98.5 % (K <sub>2</sub> SO <sub>4</sub> )	100 % (H <sub>2</sub> O)	

Measurements were started with specimens standing in a climate room with low air velocity, approx. 0.05 m/s. To minimise the influence of the external mass transfer resistances, the air velocity above the specimens was increased with a fan to about 2 m/s. This gave a slightly higher flow rate for specimens with the highest diffusion rate, but did not influence the results of the other specimens.

All tests were performed with triple or quadruple specimens of  $8 \pm 1$  mm thickness and  $63 \pm 1$  mm diameter. Individually measured values of thickness and diameter were used in the evaluation. An analytical method [14] for correction of edge effects has been used in these evaluations, as the moisture flow is not perfectly one-dimensional at the edges of our specimens.

### 3. EVALUATION

The isothermal cup measurements have been made with one external climate and five different internal climates. The aim of the evaluation is to calculate the diffusion coefficient as a function of the moisture state. We have assumed that the internal mass transfer resistance,  $Z_i$ , is equal to the resistance of stagnant air in the air gap between the salt solution and the specimen and that the external mass transfer resistance is negligible. In the present evaluations the vapour content at the internal side of the specimen was calculated as the vapour content of the salt solution minus the vapour content difference over the air gap. The external vapour content used was that of the ambient climate. Constant condition on one side of the specimen is a prerequisite for the evaluation method outlined below.

Equation 2 can be rewritten:

$$qL = \bar{D}(v_2 - v_1) \quad (4)$$

All cup measurements of a certain material and in a certain vapour content range will have the same product of mass flow rate and specimen thickness. Rewriting Eq. 1 and integrating gives:

$$\int_0^L q dx = - \int_{v_1}^{v_2} D(v) dv \quad (5)$$

The left hand side integral is  $qL$  (Eq. 4). Therefore:

$$\bar{D} = \frac{\int_{v_1}^{v_2} D(v) dv}{v_2 - v_1} \quad (6)$$

If two cup measurements are made with the same external climate  $v_0$ , but with two different internal climates  $v_1$  and  $v_2$ , it is possible to calculate the mean diffusion coefficients in two intervals:  $D_{01}$  and  $D_{02}$ . Here, Eq. 4 is written for these two measurements and for a hypothetical measurement in the interval  $v_1$  to  $v_2$ , see Fig. 2:

$$q_m L_a = \bar{D}_{02}(v_2 - v_0) \quad (7)$$

$$q_m L_b = \bar{D}_{01}(v_1 - v_0) \quad (8)$$

$$q_m L_c = \bar{D}_{12}(v_2 - v_1) \quad (9)$$

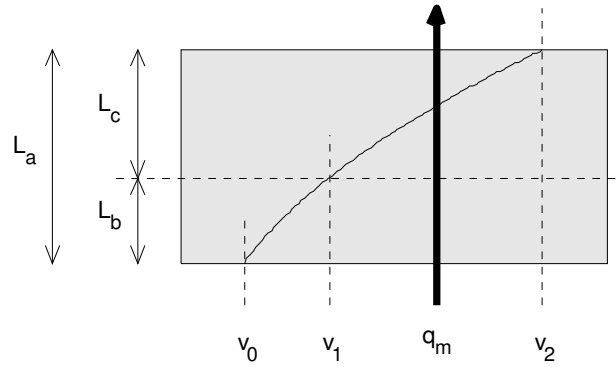

Figure 2 – A schematic drawing of a cup measurement made with a specimen of thickness  $L_a$  between vapour contents  $v_0$  and  $v_2$ . Also shown is the division of the specimen into two specimens of thickness  $L_b$  and  $L_c$  and how one will get the same flow as with the thicker specimen by making measurements in the interval  $v_0$  to  $v_1$  and  $v_1$  to  $v_2$ , respectively.

Note that these three measurements have the same flow rate and that  $L_a=L_b+L_c$ . From Eqs. 7-9 one can write the following expression for  $D_{12}$ :

$$\bar{D}_{12} = \frac{\bar{D}_{02}(v_2 - v_0) - \bar{D}_{01}(v_1 - v_0)}{v_2 - v_1} \quad (10)$$

As this equation does not include  $q$  or  $L$ , it is a general expression valid also for specimens that do not conform to the limitations of Fig. 2 (same  $q$  and  $L_a=L_b+L_c$ ). Equation 10 can thus be used to calculate mean diffusion coefficients in difference-intervals not directly measured.

Measurements were made with one external climate  $v_0$  and five different internal climates  $v_1-v_5$ .  $D_{01}, D_{02}, \dots, D_{05}$  can directly be calculated with Eq. 4 and  $D_{12}, \dots, D_{45}$  can be calculated with Eq. 10, i.e., the diffusion coefficient is obtained as a function of the moisture state. Other similar methods for evaluation have been proposed, e.g., by Chang et al. [15] and Bažant et al. [16].

## 4. RESULTS AND DISCUSSION

### 4.1 Diffusion coefficients

The results are presented in Figs. 3-5. As can be seen in Figs. 3 and 4, the rapid drying SLC B with lower water to binder ratio has a slightly lower diffusion coefficient than SLC A. When compared with normal concrete, w/c 0.7 [7], SLC A and B both have higher diffusion coefficients up to about 90 % RH. At higher RH, diffusion coefficients for concrete are significantly higher. A possible explanation of these differences may be the different pore structures of concrete and SLC. Other influential factors may be the higher aggregate content of concrete and the polymer in the SLC that forms an interspersed secondary binder system in the hydrated product (which may limit the capillary flow that dominates the moisture transport at high RH). The influence from the transition zone between aggregate and paste may also differ between concrete and SLC.



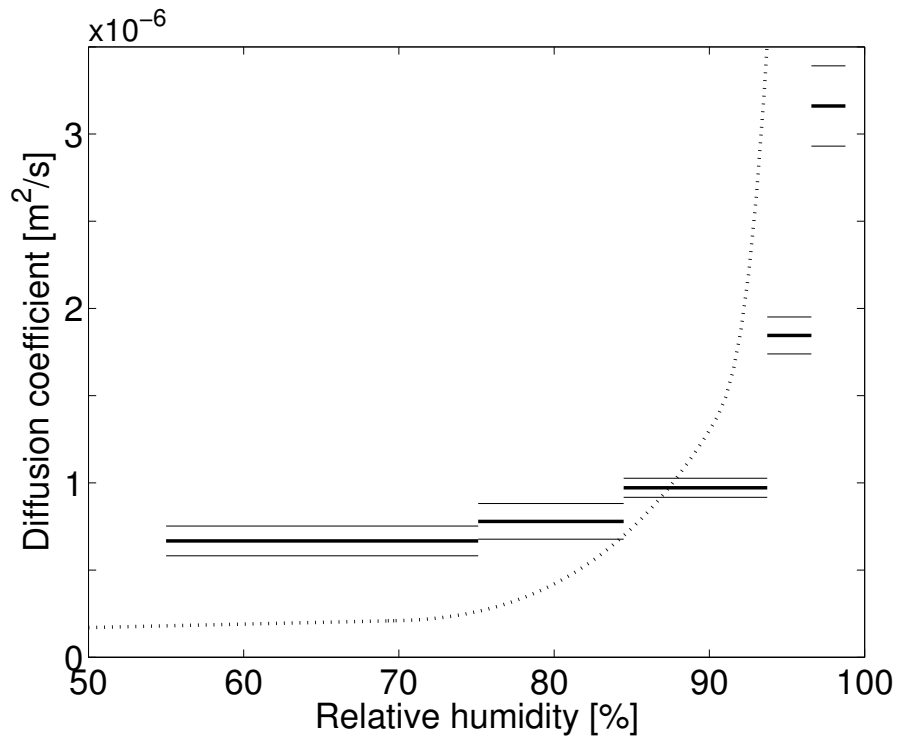

Figure 3 – Diffusion coefficient for SLC A. Thick line is the mean value in the shown interval. Thin lines indicate one standard deviation. As a comparison, a curve fit of a diffusion coefficient for concrete with water to cement ratio 0.7 [7] is given as a dotted line.

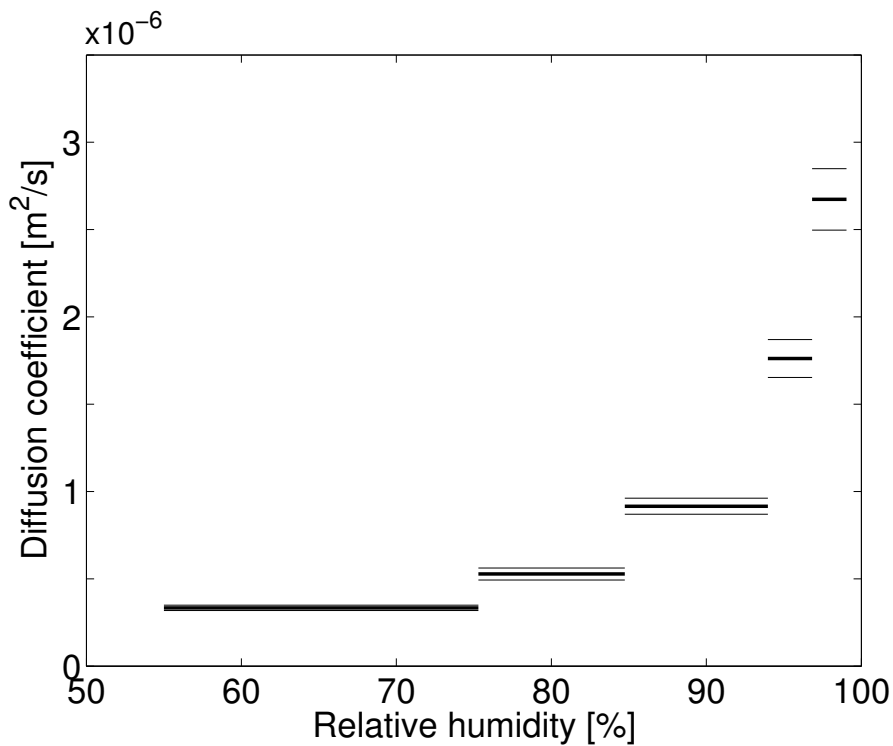

Figure 4 – Diffusion coefficient for SLC B. Thick line is the mean value in the shown interval. Thin lines indicate one standard deviation.

SLC C (Fig. 5) for industrial floors has a lower diffusion coefficient than the other two SLC (note the different scale on the y-axis in Fig. 5). This may be an effect of the higher polymer content in the industrial flooring material, the lower water to binder ratio and the slag content. Although microstructures of slag cement pastes are similar to those of Portland cement, the permeability is normally lower in slag cement pastes [18].

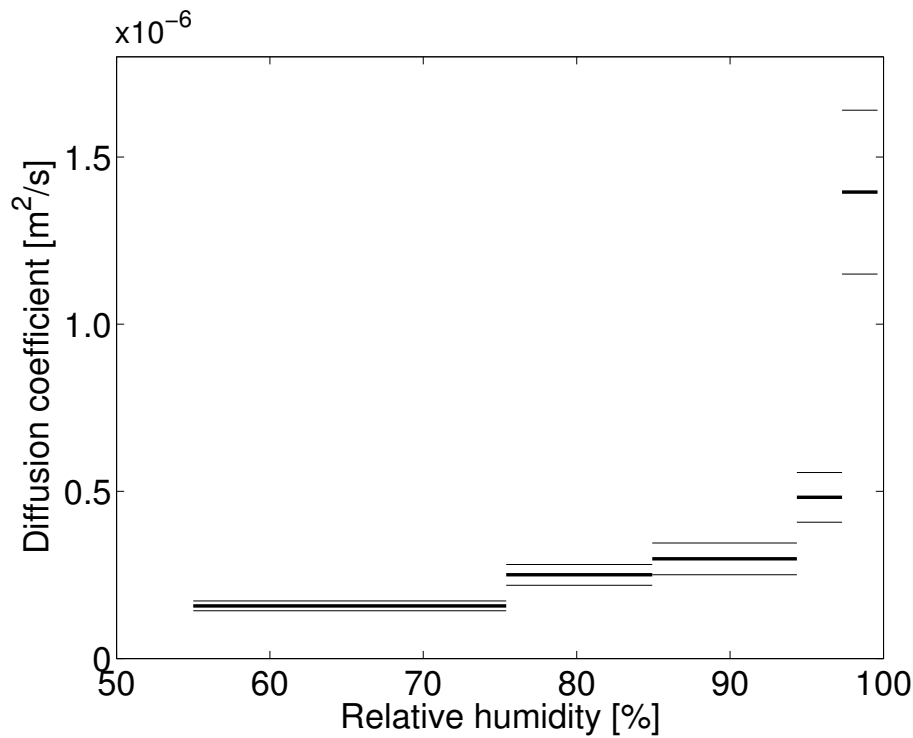

Figure 5 – Diffusion coefficient for SLC C. Thick line is the mean value in the shown interval. Thin lines indicate one standard deviation.

#### 4.2 Influence of water/binder ratio

As can be seen in Table 2, the diffusion increases with increasing water to binder ratio.

Table 2 – Mean diffusion coefficients and standard deviations for samples of product A made with different amounts of mixing water. Four replicates were measured in each sample.

Sample	RH-interval %	Diffusion coefficient $10^{-6} \text{ m}^2/\text{s}$
Normal	55-85.1	$0.70 \pm 0.02$
	55-97.6	$0.84 \pm 0.03$
+ 10 % mixing water	55-85.1	$0.85 \pm 0.03$
	55-97.6	$0.93 \pm 0.02$
- 20 % mixing water	55-85.1	$0.47 \pm 0.03$
	55-97.6	$0.59 \pm 0.03$

### 4.3 Influence of hysteresis

Most materials have sorption hysteresis as they have different isotherms for desorption (drying) and absorption (humidification). At a certain RH a drying specimen contains more water than a specimen absorbing water vapour. The influence of this on the diffusion rate has been studied by measurements of diffusion coefficients with specimens in absorption and desorption mode, respectively, Table 3. The results indicate that specimens undergoing desorption, i.e., contains more water, have higher diffusion coefficients.

*Table 3 – Mean diffusion coefficients and standard deviations for samples of product A in absorption and desorption mode. Each sample included three replicates. Note that these test specimens were older than the other test specimens and the results can therefore not directly be compared with the other results in this article.*

Sample (Product A)	RH-interval %	Diffusion coefficient $10^{-6} \text{ m}^2/\text{s}$
Absorption	55-75.5	$0.59 \pm 0.05$
Desorption	55-75.5	$0.78 \pm 0.01$
Absorption	55-97.6	$0.71 \pm 0.05$
Desorption	55-97.6	$0.90 \pm 0.05$

### 4.4 Influence of temperature

A direct comparison between measurements at 20 and 5 °C was not possible to make, as the saturated salt solutions used do not generate the same RH at different temperatures. An estimation is however possible to make and this shows that the diffusion coefficient at 5 °C is about 60 % of the diffusion coefficient at 20 °C, see Table 4.

*Table 4 – Mean diffusion coefficients and standard deviations at 20 and 5 °C for product A. Samples measured at 20 °C included four replicates and samples measured at 5 °C included three replicates.*

Temperature °C	RH-interval %	Diffusion coefficient $10^{-6} \text{ m}^2/\text{s}$
20	55-75.5	$0.67 \pm 0.09$
20	55-94.6	$0.77 \pm 0.04$
20	75.5-94.6	$0.97 \pm 0.13$
5	63.5-75.6	$0.40 \pm 0.07$
5	63.5-96.3	$0.47 \pm 0.05$
5	75.6-96.3	$0.58 \pm 0.11$

### 4.5 Influence of polymer primer

Results of measurements with and without primer (not given here) show that the resistance of the primer was in the order of 5000 s/m at 75 % RH. This corresponds to the resistance of about

4 mm of SLC A at 75 % RH. The amount of applied primer was 0.4 kg solution per m<sup>2</sup>, i.e., 0.05 kg (solid)/m<sup>2</sup>. A dependence of thickness could also be seen, where an increased amount of primer applied gave a higher resistance.

#### 4.6 General discussion

A survey of sources of uncertainty and errors in the cup method was done by Hansen and Lund [19]. The main sources of uncertainty described were surface and air space resistances, changes in barometric pressures, RH oscillations and boundary effects. In the present study, long-term measurements minimised the influence of barometric pressure changes and RH oscillations. Surface and air space resistances and boundary effects are described earlier in this paper.

When evaluating diffusion coefficients with Eq. 10, values from measurements are used both when evaluating diffusion coefficients in the measured interval and in the next interval with higher RH. This means that measurement errors in one interval also influence the calculated diffusion coefficients of the next higher interval and that the uncertainty for these calculated values increases. This can be seen in Table 4, where the last diffusion coefficients are calculated from the first two values.

Carbonation occurs in all cement-based materials. Carbonation in ettringite systems [20] and calcium aluminate cement [21] leads to a slightly more open material. Consequently, materials exposed to air should have higher diffusion coefficients than less carbonated materials. Materials in these experiments were hydrated in sealed plastic bags, but exposed to air when measurements were performed.

Evaluation of measurements with Eq. 10 requires that the material is homogeneous. Carbonation, as discussed above, can give the material slightly different properties, as the carbonation front moves from the surface and inwards into the specimen. There may also be a higher concentration of polymer in the surface region as a consequence of bleeding in the fresh mortar. Water transported from the fresh mortar to the surface may carry polymers, which then accumulates in the surface region, while the water evaporates. This higher concentration of polymers in the surface may influence the moisture transport properties and therefore give a slightly inhomogeneous material.

Measurements of moisture transport properties together with measurements of moisture storage capacities (sorption isotherms) [8] makes it possible to calculate and predict drying times, moisture loads, ion transport etc. This is important because it is well known that other materials may take harm in contact with cementitious materials under high moisture loads.

## 5. CONCLUSIONS

This study reports moisture diffusion coefficients of self-levelling flooring compounds (SLC). Moisture diffusion in SLC was found to be higher than in normal concrete at RH lower than approximately 90 %, but lower than normal concrete (w/c 0.7) at higher RH. A temperature dependence on moisture diffusion was found where the moisture diffusion coefficient at 5 °C was about 60 % of the moisture diffusion coefficient at 20 °C. Sorption hysteresis influences the moisture diffusion so that, at the same RH, a drying material has higher moisture diffusion coefficient than a material absorbing water vapour.

## 6. ACKNOWLEDGEMENTS

We thank Bo Johansson for helping us with the measurements.

## REFERENCES

1. Bornehag, C-G., et al., "Dampness in Building and Health Nordic Interdisciplinary Review of the Scientific Evidence on Associations between Exposure to "Dampness" in Buildings and Health Effects (NORDDAMP)." *Indoor Air*, Vol. 11, 2001, pp. 72-86.
2. Fennema, O.R., "*Water and Ice*", in *Food Chemistry*, O.R. Fennema, Editor. 1985, Marcel Dekker Inc. New York and Basel. pp. 23-67.
3. Sjöberg, A., "*Secondary emissions from concrete floors with bonded flooring materials - effects of alkaline hydrolysis and stored decomposition products*" P-01:2, Department of Building Materials. Chalmers University of Technology: Göteborg. 2001, 188 pp.
4. Wengholt Johnsson, H., "Flooring materials on concrete substrate - Field measurement of drying times and emissions in Gärdsrådet, Umeå (In Swedish)". NCC Teknik Göteborg. 1998, 27 pp.
5. Björk, F., et al., "Degradation of Components in Flooring Systems in Humid and Alkaline Environments." *Construction and Building Materials*, Vol. 17, 2003, pp. 213-221.
6. Alexanderson, J., "Emissions from alkali attack on adhesives and floor coverings." *Concrete*, Vol., 2001, pp. 18-19.
7. Hedenblad, G., "Material data for moisture transport calculations (In Swedish)". Byggeforskningsrådet: Stockholm. 1996, 53 pp.
8. Anderberg, A. and Wadsö, L., "Moisture in Self-levelling Flooring Compounds. Part II. Sorption Isotherms." *Nordic Concrete Research*, No. 32, 2004
9. Hoffman, A., "Effect of Redispersible Powders on the Properties of Self-Levelling Compounds". Technical paper, Wacker Polymer Systems, 20 pp.
10. Harbron, R. "*A General Description of Flow-Applied Floor Screeds-An Important Application for Complex Formulations Based on CAC*". *Proceedings*, International Conference on Calcium Aluminate Cements. Edinburgh, Scotland 2001. pp. 597-604.
11. Scrivener, K.L., et al. "*Effect of CO<sub>2</sub> and humidity on the Mechanical Properties of a Formulated Product Containing Calcium Aluminate Cement*". *Proceedings*, Ibausil. Weimar, Germany 1997, vol. 1. pp. 745-752.
12. Hedenblad, G., "Moisture permeability of some porous materials". *Report TVBM-7068*, Building Materials, Lund Technical University. 1993, 5 pp.
13. Greenspan, L., "Humidity Fixed Points of Binary Saturated Aqueous Solutions." *Journal of Research of the National bureau of Standards-A. Physics and Chemistry*, Vol. 81A, No. 1, 1976, pp. 89-96.
14. Claesson, J., Hagentoft, C.-E., and Wadsö, L., "Masked Edge Effects When Measuring Diffusion Coefficients With the Cup Method." *Polymer Engineering and Science*, Vol. 34, 1994, pp. 821-826.
15. Chang, S.C. and Hutcheon, N.B., "*Dependence of Water Vapor Permeability on Temperature and Humidity*". 1956, Trans. ASHRAE, 62. p. 437-450.
16. Bažant, Z.P. and Najjar, L.J., "Nonlinear water diffusion in nonsaturated concrete." *Materials and Structures*, Vol. 5No 25, 1972, pp. 3-20.

17. Nilsson, L.-O., "Long-term moisture transport in high performance concrete." *Materials and Structures*, Vol. 35, 2002, pp. 641-649.
18. Taylor, H.F.W., "Cement Chemistry". 2nd edition. Thomas Telford, London, 1997, 437 pp.
19. Kielsgaard Hansen, K. and Lund, H.B. "*Cup method for determination of water vapour transmission properties of building materials. Sources of uncertainty in the method*". *Proceedings*, Proceedings of the 2nd symposium "Building Physics in the Nordic Countries"1990. pp. 291-298.
20. Scrivener, K.L. "*Historical and Present Day Applications of Calcium Aluminate Cements*". *Proceedings*, International Conference on Calcium Aluminate Cements. Edinburgh, Scotland 2001. pp. 3-23.
21. Gaztañaga, M.T., Gonñi, S., and Guerrero, A. "*Accelerated Carbonation of Calcium Aluminate Cement Paste*". *Proceedings*, Calcium Aluminate Cements. Edinburgh, Scotland 2001. pp. 349-358.