



LUND UNIVERSITY

Improving Efficiency, Extending the Maximum Load Limit and Characterizing the Control-related Problems Associated with Higher Loads in a 6-Cylinder Heavy-duty Natural gas Engine

Kaiadi, Mehrzad; Tunestål, Per; Johansson, Bengt

Published in:

Proceedings of the ASME 2010 Internal Combustion Engine Division Fall Technical Conference

DOI:

[10.1115/ICEF2010-35012](https://doi.org/10.1115/ICEF2010-35012)

2010

[Link to publication](#)

Citation for published version (APA):

Kaiadi, M., Tunestål, P., & Johansson, B. (2010). Improving Efficiency, Extending the Maximum Load Limit and Characterizing the Control-related Problems Associated with Higher Loads in a 6-Cylinder Heavy-duty Natural gas Engine. In *Proceedings of the ASME 2010 Internal Combustion Engine Division Fall Technical Conference* (pp. 885-892). Article ICEF2010-35012 American Society Of Mechanical Engineers (ASME).
<https://doi.org/10.1115/ICEF2010-35012>

Total number of authors:

3

General rights

Unless other specific re-use rights are stated the following general rights apply:

Copyright and moral rights for the publications made accessible in the public portal are retained by the authors and/or other copyright owners and it is a condition of accessing publications that users recognise and abide by the legal requirements associated with these rights.

- Users may download and print one copy of any publication from the public portal for the purpose of private study or research.
- You may not further distribute the material or use it for any profit-making activity or commercial gain
- You may freely distribute the URL identifying the publication in the public portal

Read more about Creative commons licenses: <https://creativecommons.org/licenses/>

Take down policy

If you believe that this document breaches copyright please contact us providing details, and we will remove access to the work immediately and investigate your claim.

LUND UNIVERSITY

PO Box 117
221 00 Lund
+46 46-222 00 00

September 12-15, 2010, San Antonio, Texas, USA

ICEF2010-35012

Improving Efficiency, Extending the Maximum Load Limit and Characterizing the Control-related Problems Associated with Higher Loads in a 6-Cylinder Heavy-duty Natural gas Engine

Mehrzad Kaiadi

Division of Combustion Engines
Department of Energy Science
Faculty of Engineering
Lund University, Sweden

Email: mehrzad.kaiadi@energy.lth.se

Per Tunestal

Bengt Johansson

Division of Combustion Engines
Department of Energy Science
Faculty of Engineering
Lund University, Sweden

Email: per.tunestal@energy.lth.se

Email: bengt.johansson@energy.lth.se

ABSTRACT

High EGR rates combined with turbocharging has been identified as a promising way to increase the maximum load and efficiency of heavy duty spark ignition Natural Gas engines. With stoichiometric conditions a three way catalyst can be used which means that regulated emissions can be kept at very low levels. Most of the heavy duty NG engines are diesel engines which are converted for SI operation. These engine's components are in common with the diesel-engine which put limits on higher exhaust gas temperature. The engines have lower maximum load level than the corresponding diesel engines. This is mainly due to the lower density of NG, lower compression ratio and limits on knocking and also high exhaust gas temperature. They also have lower efficiency due to mainly the lower compression ratio and the throttling losses. However performing some modifications on the engines such as redesigning the engine's piston in a way to achieve higher compression ratio and more turbulence, modifying EGR system and optimizing the turbocharging system will result in

improving the overall efficiency and the maximum load limit of the engine.

This paper presents the detailed information about the engine modifications which result in improving the overall efficiency and extending the maximum load of the engine. Control-related problems associated with the higher loads are also identified and appropriate solutions are suggested.

INTRODUCTION

Most of the existing heavy duty engines are run on diesel. The overall engine efficiency and the maximum load of diesel engines are good however they suffer from high levels of emissions mainly NOX and soot. Natural Gas (NG) is an alternative to Diesel due to the lower emissions level, lower cost and vast available resources [1]. Two main concepts for operating heavy duty NG engines exists namely Stoichiometric or Lean operation. Recent studies at department of energy science at Lund University has shown good potentials with stoichiometric operation since stoichiometric

operation with a three way catalyst results in very low emissions while keeping efficiency at a reasonable level [2]. Still the heavy duty NG engines have lower overall efficiency and lower maximum load in compare with diesel engines. The lower overall efficiency is due to three reasons. First the lower compression ratio used with NG engines due to knocking phenomena results in higher heat losses in form of exhaust energy and thereby lower efficiency. Second, the use of throttle results in throttling losses and thereby higher pumping losses. Finally, due to the stoichiometric operation of the engine somewhat lower combustion efficiency is achieved in compare with diesel engines [2]. Normally heavy duty diesel engines are converted to NG engines. Diesel engines have lower exhaust gas temperature due to their higher expansion and also lean operating conditions. The NG engine operates stoichiometric, with lower compression ratio which results in higher exhaust gas temperature. These limitations on the exhaust gas temperature level together with knocking and lower density of NG limits the maximum load level of the engine.

There exist big potentials to improve the overall efficiency and extend the maximum load level of the engine. Increasing compression ratio and extending the dilution limit can be good strategies to improve the engine efficiency. At low and part loads the throttling losses are high. Using EGR minimizes throttling losses at lower loads and results in higher Gas-Exchange efficiency however the amount of EGR and the gain is limited due to longer combustion duration which results in increasing cyclic variation [3]. The benefits of running the engine on the maximum dilution limit are reported in [4], [5] and [6]. The dilution limit can be extended by increasing the turbulence level in the engine. Higher turbulence level results in faster combustion which consequently extends the dilution limit. The shape of pistons can affect the turbulence level in internal combustion engines. In [7], [8] and [9] the effect of different combustion chambers shape on gas flow, combustion and emissions have been studied.

The main objective of this paper is to improve the overall engine efficiency and also extend the maximum load level of the engine. It is also desired to characterize the control-related problems associated with higher loads at higher engine speeds. Some modifications are performed on the engine to approach this target. The compression ratio of the engine was increased from 10.5 to 12 and the piston shape was designed in away to reduce the combustion duration. The chosen piston shape is based on the results reported in [7]. The new piston modification resulted in some changes in the exhaust gas characteristics. This was the reason to replace the turbocharger with a Variable Geometry Turbocharger (VGT) for adjusting the boost pressure level and thereby the maximum load. The engine's EGR system is also modified in a way to

deliver more EGR rate into the engine and also to enable us to control it in a faster and more robust way.

The results showed good improvements in engine efficiency and also significant extending in the maximum load level of the engine.

EXPERIMENTAL SETUP

In this section the specification of the experimental engine and its control system, new modification on the engine, measurement system and gas data are described.

The experimental engine

The experimental engine was originally a diesel engine from Volvo which has been converted to a NG engine, see Table 1 for specification. The engine is equipped with a short route cooled EGR system and also turbocharger with wastegate.

Number of Cylinder	6
Displacement	9,4 Liter
Bore	120 mm
Stroke	138 mm
Compression ratio	10,5 :1
Fuel	Natural gas
Injection System	Multi-port

Table 1: Specification of the engine

Engine Control System

A master PC based on GNU/Linux operating system is used to operate the engine and data acquisition. It communicates with three cylinder-control-modules (CCM) for cylinder-individual control of ignition and fuel injection via CAN communication. Crank and cam information are used to synchronize the CCMs with the crank rotation. Flexible controller implementation is achieved using Simulink and C-code is generated using the automatic code generation tool of Real Time Workshop (RTW). The C-code is then compiled to an executable program which communicates with the main control program.

New modifications on the engine

Some modifications have been performed on the engine in order to improve the overall efficiency and extend the maximum load limit of the engine. The main modifications were performed on the pistons and the EGR system. In the following subsections these modifications are described in details.

Combustion chamber

As it is described in the introduction section, in order to approach the objectives of this project the original pistons were replaced by new ones. Figure 1

shows the original combustion chamber which has 10.5 in compression ratio. New pistons called *Quartette* was designed mainly based on the results presented in [7] (see Figure 2). *Quartette* has shown good ability to generate high turbulence level and it is pointed out as fast combustion chamber in [7].

The differences between the design of the piston shown in Figure 2 and the combustion chamber design in [7] are two points. The existing pistons have oil galleries and in order to not machine them some fillets are designed. In the bed of the piston bowl reported in [7] the form is completely flat but this piston has a conical form. The compression volume of the combustion chamber is decreased in order to increase the compression ratio from 10.5 to 12.



Figure 1: The original piston of the engine



Figure 2: The new piston of the engine (*Quartette*)

EGR System

The engine is equipped originally with a short route EGR system. This EGR system is also called High Pressure (HP) EGR system. In order to increase the ability for delivering more EGR and also controlling the EGR rate in a faster and more robust way a long route EGR system so called Low Pressure (LP) is added to

the engine. Figure 3 shows the long route EGR system added to the engine. Moreover a back pressure valve was installed after the catalyst for increasing the exhaust pressure and delivering more EGR. This type of EGR system (HP + LP) is previously presented in [10].

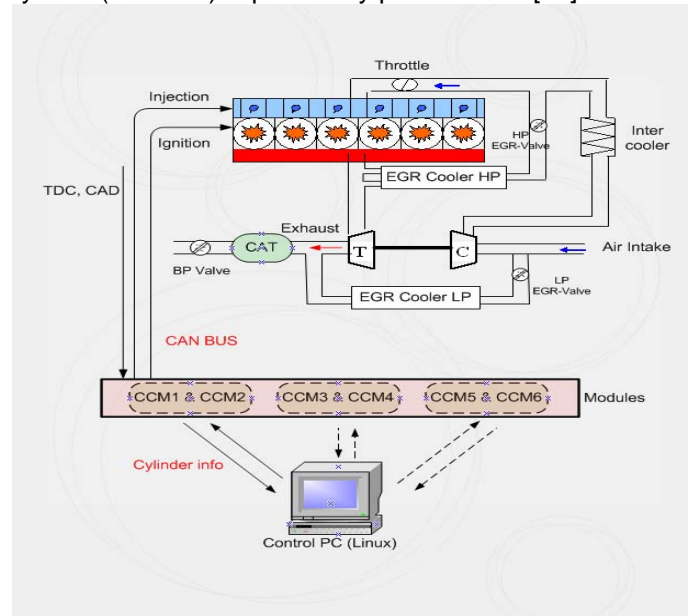

Figure 3: The engine setup with both short and long route EGR system

Measurement System

Each cylinder head is equipped with a piezo-electric pressure transducer of type Kistler 7061B to monitor cylinder pressures for heat release calculations. Cylinder pressure data are sampled by a Microstar 5400A data acquisition processor. EGR was calculated by measuring CO₂ at inlet and exhaust. Emissions (HC, CO, NO, NO₂, CO₂, O₂) are measured before and after catalyst. Also, temperatures at inlet/exhaust, pressures at inlet/exhaust, fuel and air flow, lambda, torque and engine speed are measured.

Gas Data

The composition of the NG, is shown in Table 2. The lower heating value of the NG is 48,4 MJ/kg.

Composition	%	Structure
Methane	89,84	CH ₄
Ethane	5,82	C ₂ H ₆
Propane	2,33	C ₃ H ₈
I-Butane	0,38	C ₄ H ₁₀
N-Butane	0,52	C ₄ H ₁₀
I-Pentane	0,11	C ₅ H ₁₂
N-Pentane	0,07	C ₅ H ₁₂
Hexane	0,05	C ₆ H ₁₄
Nitrogen	0,27	N ₂
CO ₂	0,6	CO ₂

Table 2: The natural gas composition

EXPERIMENTS

To investigate and quantify the effects resulted from the modifications on the engine; different experiments were designed and performed. The experiments were performed in three stages as follow:

1. To quantify the effects of the combustion chamber modifications, the engine was operated at different load and engine speeds. Since it was desired to quantify the impacts especially at higher loads, and also to identify the control-related problems at higher loads extra focus was done on engine operation with Wide Open Throttle (WOT) at different engine speed.
2. An EGR sweep was performed in order to quantify the extension of the dilution limit. The engine was operated at 1000 RPM and 10 bar Brake Mean Effective Pressure (BMEP).
3. Based on the results from experiment 1 it was decided to change the turbocharger. The turbocharger was replaced by a VGT and new experiments were performed mainly to investigate how the maximum load limit can be extended and also to identify the possible problem associated with the higher loads operation.

Lambda is kept equal to one and the start of injection is fixed for all operating points. The ignition timing is set at the Maximum Brake Torque (MBT) until knock was observed. When observing knock, EGR is added and ignition timing is adjusted based on that. The inlet temperature was maintained constant at 313 K. For each operating point 300 cycles data were sampled and a mean value of them are presented in the plots.

RESULTS

The results of the experiments are evaluated in form of combustion duration, efficiency, maximum load level, emissions and other important parameters.

Combustion Duration

As it was discussed in the previous section the main feature of the Quartette combustion chamber is its high ability to generate turbulence. Figure 4 shows the combustion duration comparison for the two piston configurations. The Quartette piston speeds up the combustion due to its high turbulence level and thereby it shortens the combustion duration by almost 40%. Combustion duration is calculated in the period of 10% to 90% mass burned fraction.

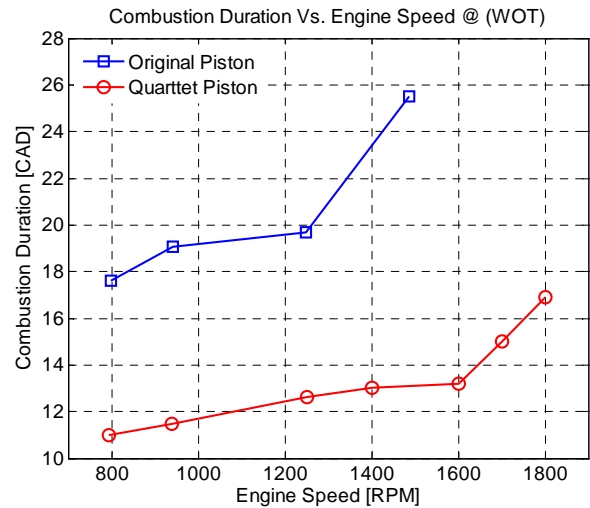

Figure 4: Combustion duration (CA10-CA90) @ different engine speed (WOT)

Efficiency

A fast combustion chamber shortens the combustion duration which consequently reduces the heating losses and also extends the dilution limit of an engine. Gross indicated efficiency is an indication of how good the combustion is and also how big the heat losses are. It is defined as

$$\eta_{GI} = \left(\frac{IMEP_{gross}}{\left(\frac{m_f Q_{LHV}}{V_D} \right)} \right) \quad \text{Where}$$

$IMEP_{gross}$ = Gross Indicated Mean Effective Pressure

m_f = fuel mass per cycle

Q_{LHV} = lower heating value of the fuel

V_D = displacement volume

Gross indicated efficiency was plotted versus different engine speeds when the throttle is fully open. Figure 5 shows that gross indicated efficiency is improved by at least two percent unit. This improvement was expected since the heat losses was expected to be lower with the new combustion chambers due to two main reasons. Two major modifications were performed on the combustion chambers namely their shape and the compression ratio. The modifications on the pistons shape minimize the heating losses in form of wall heat losses since the combustion is much faster. Increasing in the compression ratio increases the expansion ratio which results in lower exhaust losses.

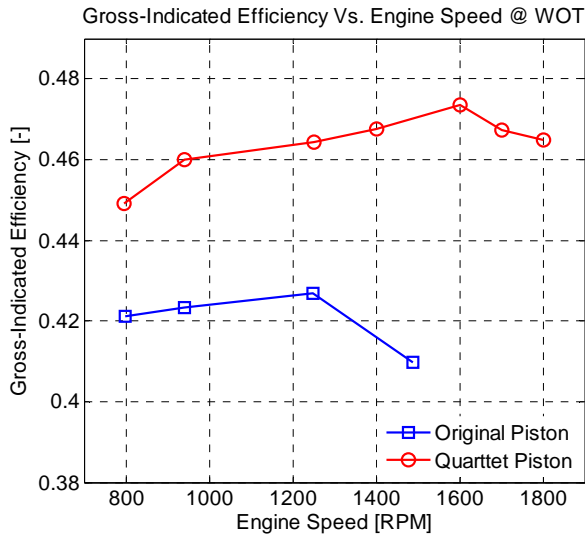

Figure 5: Gross indicated efficiency @ different engine speed (WOT)

Gross indicated efficiency is a product of combustion efficiency and thermodynamic efficiency. The combustion efficiency is an indication to how good the fuel burns in the cylinder. Thermodynamic efficiency is an indication of the amount of heat losses in form of wall, blow-by and Crevices heating losses and also exhausts energy.

Figure 6 show that the Quartette piston offers higher Thermodynamic efficiency due to partly its higher compression and partly due to the faster combustion chamber.

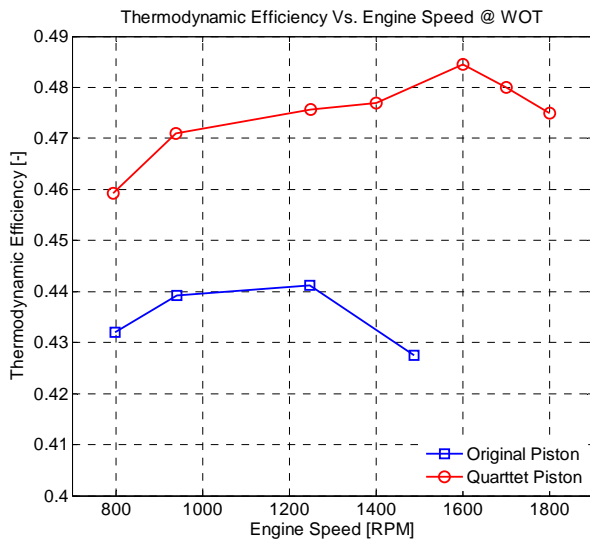

Figure 6: Thermodynamic efficiency @ different engine speed (WOT)

Dilution Limit

As it is mentioned in the introduction and experimental setup sections, some modifications have been performed on the EGR system. The engine was only equipped with a short rout EGR system and the

amount of deliverable EGR was limited to only 20%. A long rout EGR system and a back pressure valve were added to the engine. The main reason for this modification was to increase the EGR rate and also to control the amount of EGR in a faster and more robust way.

An EGR sweep was made basically for two reasons. First, to investigate the maximum level of EGR rate that can be delivered by the new EGR configuration and second, to find out how much the dilution limit is extended since a faster combustion chamber is also used. The engine was able to deliver about 20% EGR with the original short rout system but by the new system this amount is only limited to the dilution tolerance of the engine. Figure 7 and Figure 8 show how cyclic variation of each cylinder for the original and the Quartette piston looks like by increasing EGR rate. They show that the dilution limit is extended from about 18% EGR to about 24 % EGR with the Quartette piston.

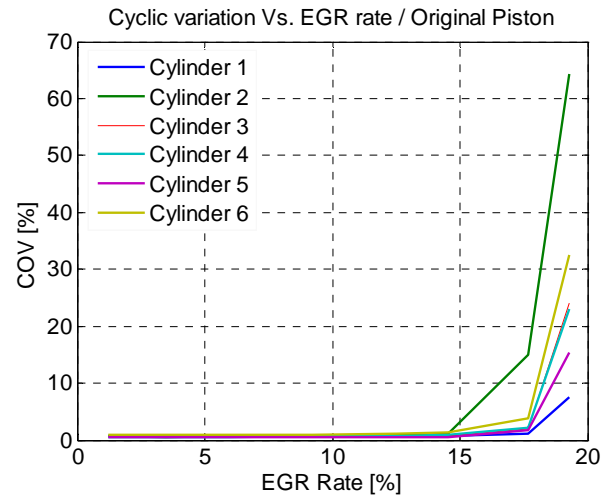

Figure 7: Cyclic variation Vs. EGR rate for the original piston

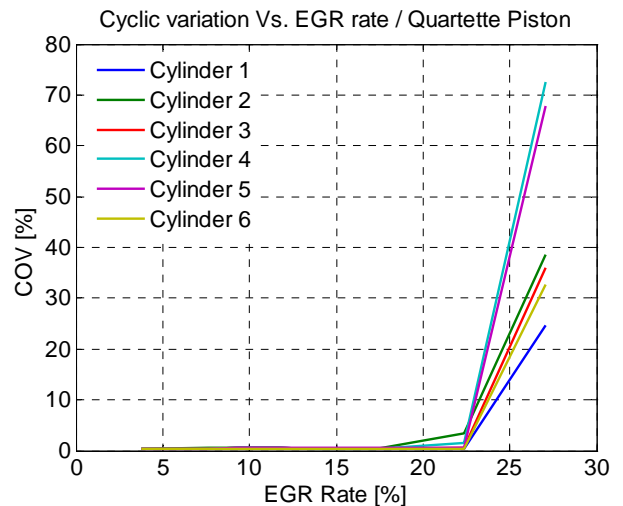

Figure 8: Cyclic variation Vs. EGR rate for the Quartette piston

The Maximum Load Limit

Since one of the objectives of this project is to extend the maximum load level of the engine, the maximum load for both pistons was compared. Figure 9 shows BMEP versus different engine speeds at WOT. By using Quartette pistons the maximum achieved loads are somewhat lower than the loads achieved by the original pistons. To investigate the reason, the pressure after the compressor for the corresponding operating points are plotted and compared in Figure 10.

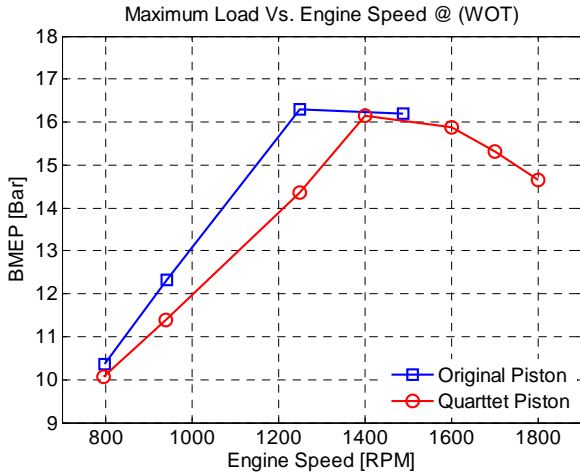

Figure 9: Maximum Load @ different engine speed (WOT)

The pressure after the compressor is higher with the original pistons which mean that the work delivered by the turbocharger is more. Work is done by the flow to turn the turbine and the shaft. From the conservation of energy, the turbine work per mass of airflow (W) is equal to the change in the specific enthalpy (h) of the flow from the entrance to the exit of the turbine. By specific enthalpy means the enthalpy per mass of airflow.

$$W = h_{in} - h_{out}$$

The enthalpy at the entrance and exit of the turbine is related to the total temperature T at those points.

$$W = c_p (T_{in} - T_{out})$$

This equation can be rewritten to [11]

$$W = (c_p \times \eta \times T_{in}) \times \left[1 - P_r^{\left(\frac{\gamma-1}{\gamma}\right)} \right]$$

From this equation it is clear that the inlet temperature of the turbine will affect the amount of work done by the turbine. Figure 11 shows the exhaust gas temperature which is same as inlet temperature of the turbine versus the different engine speed for the experimented operating points. With the Quartette pistons exhaust gas temperature is lower than the original pistons. This is due to the higher compression ratio of the Quartette which results in more expansion. More expansion means that more heat converted into mechanical work in the cylinder and less energy in form of exhaust gas are available. The lower exhaust

temperature means lower exhaust energy and thereby less charging from turbocharger.

As it is mentioned in the introduction section, the exhaust gas temperature from these types of NG engines must be kept at low levels. According to the manufacturer the exhaust gas temperature should be lower than 760°C with this engine. The lower exhaust gas temperature is beneficial in two ways. First, the higher margin is available to the highest allowable exhaust gas temperature and second, there exists potential that by replacing the turbocharger by a better matched turbocharger, the maximum load limit will be extended.

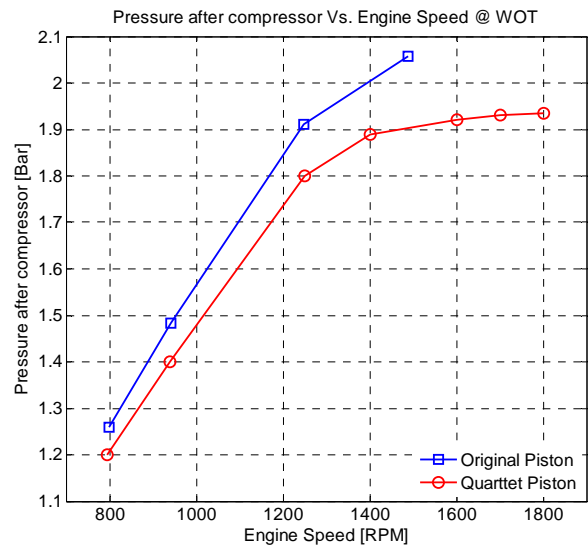

Figure 10: Pressure after compressor @ different engine speed (WOT)

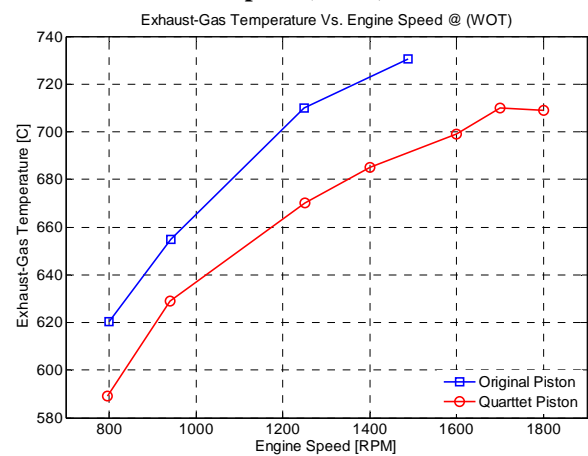

Figure 11: Exhaust gas temperature @ different engine speed (WOT)

Extending the Maximum Load Limit

It was showed and discussed in the results section that the lower exhaust gas temperature with the Quartette pistons results in lower boost pressure from the turbocharger. This fact plus the need to extend the

maximum load limit of the engine (one of the objectives of this work) points out the need for more boost pressure.

A well matched VGT is a good alternative to be used instead of the existing turbocharger with wastegate for achieving the right amount of boost pressure. VGT is a good choice since compare with the bypass control turbocharger it offers the flexibility to adjust the required boost pressure. Moreover, There is also potential to reduce the throttling losses by means of VGT. This will be investigated in the next paper.

VGT is used widely in turbo diesel engines. Traditionally turbochargers with wastegate have been used on SI engines. VGT is not used on SI petrol engines. This is because petrol engine exhaust gases are a lot hotter than diesel engine exhaust gas, so generally the material used to make VTG turbo could not stand this heat [12]. The heavy duty SI NG engines have higher exhaust gas temperature than the diesel engines but it is still much lower than the exhaust gas temperature from the petrol engines. So there is no limitation to use VGT on the NG engine.

After consulting with the R&D group from engine contractor Company a VGT was delivered and mounted on the engine. The engine is operated at the same engine speeds at WOT and the boost increased until the knock occurs. EGR is added to suppress the knocking. The black line in Figure 12 shows the maximum load when the engine was operated on VGT. In the same plot it is compared with the two previous experiments. The peak BMEP is increased by at least 3 bar from 16 to 19 which is a significant improvement.

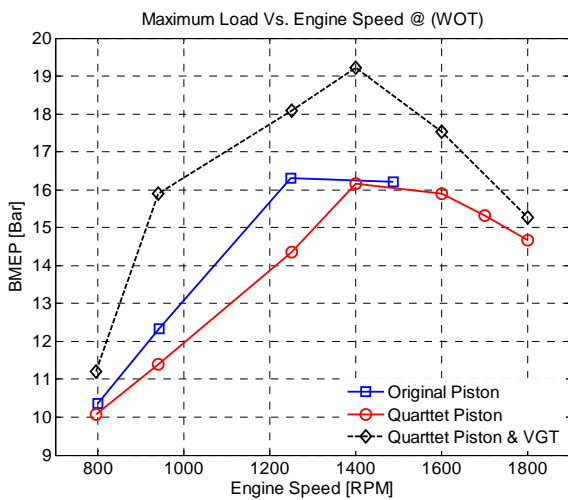

Figure 12: Maximum load after replacing the turbocharger to a VGT in compare with the other configurations

Control-related problems associated with the higher loads and suggested solution

Higher boost pressure and higher loads in the engine is limited to knock phenomena. A very sophisticated control strategy should be designed to control the knock at the higher loads. To suppress knock at the higher loads, right amounts of EGR have to be added and the ignition timing should to be adjusted based on that. The new configuration of the EGR system (LP+HP) plus fast measurements of the EGR rate are the right tools to control that in a fast and robust way. Measurements of EGR have to be done in a very fast way to delete the measurement lag.

Midrange control of EGR is an appropriate option for controlling the 2 EGR valves. Mid-range control structure is used for processes with two inputs and only one output [13]. A classical application of this type of controllers is valve position control. Figure 13 demonstrate a mid-range control strategy. The faster process input u_1 should be used for a small range valve and then the slower process input u_2 should be used for the large range valve. The controllers should have separate time scales to avoid interactions.

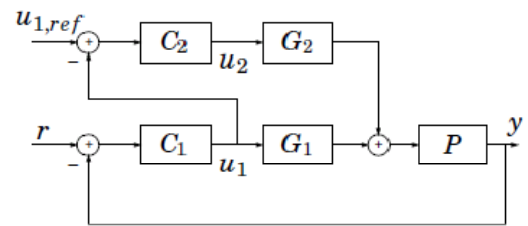

Figure 13: Mid-range control strategy

SUMMARY / CONCLUSION

The main objective of this work was to improve the overall efficiency and extend the maximum load level. It was also desired to identify and characterize the problems associated with higher loads. Some modifications were performed on the combustion chambers, EGR system and the turbocharging system. The pistons shapes were modified in away to increase the turbulence level and also the compression ratio. A LP EGR route and a back pressure valve were also added to the engine to increase the EGR deliverability of the engine and also to control the EGR rate in a faster and robust way. The turbocharger was also replaced by a VGT in order to adjust the boost pressure at higher loads.

The achieved results are evaluated in terms of combustion duration, efficiency, dilution limit and the maximum load limit. The Following conclusions obtained after this study:

- **Improving Engine Efficiency**
 - Gross indicated efficiency was increased with the new combustion chambers due to the lower heating losses

- The higher compression ratio results in more expansion and thereby lower heat losses in form of exhaust energy
- The shape of the combustion chamber results in more turbulence and thereby much faster combustion. This fact results in lower heating losses to the walls and Crevices
- Extending the Dilution Limit
 - By the new EGR system higher EGR rate can be achieved and for controlling the EGR rate more freedom of degree are available.
 - Dilution limit is extended from about 18% EGR to 24% EGR due to the faster combustion chamber
 - Extending the dilution limit means reducing the pumping losses at lower load and thereby improving efficiency
- **Extending Load Limit**
 - Somewhat lower Maximum load level achieved with the new combustion chambers due to the lower exhaust gas temperature. The higher compression ratio resulted in more expansion and thereby lower exhaust temperature. This resulted in lower boost from turbocharger and lower inlet pressure.
 - Better matched turbocharger was needed, so the turbocharger with bypass was replaced by a VGT
 - The heavy duty SI NG engines have higher exhaust gas temperature than the diesel engines but it is still much lower than the exhaust gas temperature from the petrol engines. So there is no limitation to use VGT on the NG engine.
 - Using VGT resulted in significant improvement in maximum achievable load
- **Higher load Problems**
 - In this type of NG engines, exhaust gases temperatures are limited to 760°C. By the Quartette pistons since the compression ratio is higher that results in more expansion and thereby lower exhaust temperature. This means that higher compression ratio is a remedy to this problem
 - Knocking seems to be a limit for more boost pressure and higher BMEP level
 - Sophisticated controllers should be developed to suppress the knock at higher loads.
 - HP+LP EGR configuration combined with Mid-range control strategy seems to be a promising concept to be used in controlling the EGR rate

In the next work it will be tried to implement the Mid-range control of EGR. The EGR controller can be used to suppress knock at higher loads and reducing throttle

losses at lower loads. Minimizing the throttling losses by means of VGT will also be studied.

REFERENCES

- [1] Energy Information Administration (EIA), International Energy Annual 2005 (June-October 2007), web site www.eia.doe.gov/iea. Projections: EIA, World Energy Projections Plus (2008)
- [2] P. Einewall, P. Tunestål, B. Johansson "Lean Burn Natural Gas Operation vs. Stoichiometric Operation with EGR and a Three Way Catalyst" SAE Technical Paper 2005-01-0250
- [3] J.B. Heywood "Internal Combustion Engine Fundamentals", International edition, McGraw-Hill, New York, 1988
- [4] G. Zhu, C. Daniels, J. Winkelman, I. Haskara "Closed Loop Maximum Dilution Limit Control using In-Cylinder Ionization Signal" SAE Technical Paper 2005-01-3751
- [5] M Kaiadi, P Tunestål, B Johansson: "Closed-Loop Combustion Control for a 6-Cylinder Port-Injected Natural Gas Engine" SAE Technical Paper 2008-01-1722
- [6] M Kaiadi, P Tunestål, B Johansson: "Closed-Loop Combustion Control Using Ion-Current Signals in a 6-Cylinder Port-Injected Natural Gas Engine" SAE Technical Paper 2008-01-2453
- [7] P. Einewall, B. Johansson "Combustion Chambers for Supercharged Natural Gas Engine" SAE Technical Paper 970221
- [8] B. Johansson, K. Olsson "Combustion Chambers for Natural Gas SI Engines Part 1: Fluid Flow and combustion" SAE Technical Paper 950469
- [9] K. Olsson, B. Johansson "Combustion Chambers for Natural Gas SI Engines Part 2: Combustion and Emissions" SAE Technical Paper 950517
- [10] M. Kobayashi, Y. Aoyagi, T. Adachi, T. Murayama, A. Noda, Y. Goto, H. Suzuki "Effect of High Boost and High EGR on the Super Clean Diesel Engine" COMODIA 2008, OS-A1
- [11] HIH. Saravanamuttoo, GFC. Rogers, H. Cohen "Gas Turbine Theory" Book, 5th edition, 2001
- [12] R. Bosch GmbH "Automotive Handbook" Book, 6th edition, 2004
- [13] T. Glade, L. Ljung "Control Theory — Multivariable and Nonlinear Methods" Book, English edition, 2000