



LUND UNIVERSITY

A comparison of DFT and SVD based channel estimation in MIMO OFDM systems

Hammarberg, Peter; Edfors, Ove

Published in:

2006 IEEE 17th International Symposium on Personal, Indoor and Mobile Radio Communications (IEEE Cat. No. 06TH8881)

DOI:

[10.1109/PIMRC.2006.253938](https://doi.org/10.1109/PIMRC.2006.253938)

2006

[Link to publication](#)

Citation for published version (APA):

Hammarberg, P., & Edfors, O. (2006). A comparison of DFT and SVD based channel estimation in MIMO OFDM systems. In *2006 IEEE 17th International Symposium on Personal, Indoor and Mobile Radio Communications (IEEE Cat. No. 06TH8881)* IEEE - Institute of Electrical and Electronics Engineers Inc.. <https://doi.org/10.1109/PIMRC.2006.253938>

Total number of authors:

2

General rights

Unless other specific re-use rights are stated the following general rights apply:

Copyright and moral rights for the publications made accessible in the public portal are retained by the authors and/or other copyright owners and it is a condition of accessing publications that users recognise and abide by the legal requirements associated with these rights.

- Users may download and print one copy of any publication from the public portal for the purpose of private study or research.
- You may not further distribute the material or use it for any profit-making activity or commercial gain
- You may freely distribute the URL identifying the publication in the public portal

Read more about Creative commons licenses: <https://creativecommons.org/licenses/>

Take down policy

If you believe that this document breaches copyright please contact us providing details, and we will remove access to the work immediately and investigate your claim.

LUND UNIVERSITY

PO Box 117
221 00 Lund
+46 46-222 00 00

A COMPARISON OF DFT AND SVD BASED CHANNEL ESTIMATION IN MIMO OFDM SYSTEMS

Peter Hammarberg
Lund University
Lund, Sweden

Ove Edfors
Lund University
Lund, Sweden

ABSTRACT

In this paper two simplified transform based estimators for MIMO OFDM systems using the DFT and an SVD based transform are compared over a tapped delay line channel model. In the resulting symbol error rate plots it is seen that the DFT based estimator will experience an error floor caused by the mismatch between the discrete time model and a continuous time reality. This error floor becomes a problem at high SNR levels where high data-rate systems can be expected to operate. When using an SVD based estimator it is seen that this error floor is reduced at the cost of a somewhat increased estimator complexity.

I. INTRODUCTION

As wireless services become more and more advanced, higher data rates need to be achieved in the communication systems. To overcome the limiting factor of the available bandwidth, multiple-input – multiple-output (MIMO) antenna systems have been proposed to increase channel capacity over a fixed spectrum [1]. To tackle another large problem in wireless communication, the problem caused by multipath fading channels, orthogonal frequency division multiplexing (OFDM) has been proposed. The technique simplifies the channel equalisation process [2]. By using MIMO systems in combination with OFDM an efficient communication system can be formed with high spectral efficiency and low sensitivity to multipath fading.

To get these systems to work and to further increase the spectral efficiency by introducing coherent modulation, efficient techniques for channel estimation have to be used. By performing the estimation in an appropriate transform domain, efficient low-rank estimators can be found. This is achieved by using the fact that for a well-designed OFDM system the energy of the impulse response will be concentrated to a fraction of the symbol length. A number of different algorithms have been presented for transform based channel estimation in MIMO OFDM systems. Discrete Fourier transform (DFT) has been used to perform simplified channel estimation in the cyclic time domain [3]. An alternative transform obtained from a singular value decomposition (SVD) of the channel auto correlation matrix has also been used [4]. Both these approaches stem from channel estimators for traditional OFDM systems [5,6].

In this paper a comparison of a DFT based estimator and an estimator using an SVD based transform for MIMO OFDM systems is performed using a tapped delay line channel model. The performance of the two estimators is evaluated for both sample-spaced channels and non-sample spaced channels, which better match the behaviour of real wireless chan-

nels. The results show that the performance gain at high SNRs obtained by using a SVD based transform is significant if the channel is non-sample spaced.

II. CHANNEL MODEL

Assuming the channel to be wide sense stationary with uncorrelated scatters, a tapped delay line model is formed for the impulse response [5]

$$g(\tau, t) = \sum_{n=1}^R \alpha_n(t) \cdot \delta(t - \tau_n(t)) \quad (1)$$

where $\alpha_k(t)$ are independent zero mean complex Gaussian processes, with Rayleigh distributed amplitudes, power delay profile $\theta(\tau_n)$. The delays are $\tau_n(t)$, where $n=1, \dots, R$ and t is the absolute time. The power delay profile is treated as either uniform, $\theta(\tau_n) = C$, or exponentially decaying, $\theta(\tau_n) = C \cdot e^{-\tau_n/\tau_{rms}}$, over the interval $[0, L \cdot T_s]$ where L is the channel length in samples, T_s is the sampling period and τ_{rms} is the root-mean squared delay factor. The R delays are considered to be uniformly distributed within the length of the cyclic prefix (CP).

The impulse response is assumed to be constant over the duration of one OFDM symbol. (1) can therefore be written, without time dependence, as

$$g(\tau) = \sum_{n=1}^R \alpha_n \cdot \delta(\tau - \tau_n) \quad (2)$$

For an OFDM system with N carriers, the frequency response on sub-carrier k , $h[k]$, is found by calculating the Fourier transform of (2) at normalized frequency $f = f_k = k/N$ [8]

$$h[k] = \sum_{l=0}^{N-1} \sum_{n=1}^M \alpha_n e^{-j2\pi l \frac{k}{N} \tau_n} \quad (3)$$

III. SYSTEM

The system used here is a 2×2 antenna system using OFDM. Each OFDM symbol consists of N samples and the length of the CP is set to L samples. The system thus consists of four different antenna-to-antenna channels, all treated as independent and linear. The received signal at antenna j $r_j[k]$, where $k=1, \dots, N$, is a linear combination of the transmitted signals. In the frequency domain this can be expressed as

$$r_j[k] = \sum_{i=1}^{N_T} h_{ij}[k] \cdot s_i[k] + w_j[k] \quad (4)$$

where N_T is the number of transmit antennas, $h_{ij}[k]$ the channel frequency response of the k^{th} sub-channel between the i^{th} transmitter and j^{th} receiver antenna, $s_i[k]$ is the signal from the i^{th} transmitting antenna and $w_j[k]$ is the noise on the j^{th} receiver branch, which here will be treated as complex white Gaussian noise with zero mean and variance σ_n^2 .

IV. ESTIMATORS

The first estimator presented is a simplified version of the DFT based estimator described in [3]. The simplification lies in that the time-domain filtering is removed. This will not affect the general conclusions, since the impairments studied are due to a mismatch in the frequency-domain filtering only. For a well-designed OFDM system the channel energy is focused to the first taps of the impulse response $g[l]$. Ignoring the channel energy outside the first M taps, the frequency response, $h_i[k]$, for the k^{th} sub-channel corresponding to the i^{th} transmitting antenna, is given by the N point Fourier transform of the first M values

$$h_i[k] = \sum_{l=0}^{M-1} g_i[l] W_N^{kl} \quad (5)$$

where $W_N = e^{-j2\pi l/N}$ and N is the number of sub-channels. Using (4) the received signal at the j^{th} receiver is given by

$$r_j[k] = \sum_{i=1}^{N_T} \left(\sum_{l=0}^{M-1} g_{ij}[l] W_N^{kl} \right) \cdot s_i[k] + w_j[k] \quad (6)$$

where $g_{ij}[l]$, $l=0, \dots, M-1$, is the channel impulse response between the i^{th} transmitter and j^{th} receiver antenna.

If the transmitted signals are known through the use of training symbols, an LMMSE estimation of the impulse response at the j^{th} antenna can be derived. The estimator can be written in matrix form as [3]

$$\begin{bmatrix} \tilde{g}_1 \\ \vdots \\ \tilde{g}_{N_T} \end{bmatrix} = \begin{bmatrix} \mathbf{Q}_{11} & \cdots & \mathbf{Q}_{1N_T} \\ \vdots & \ddots & \vdots \\ \mathbf{Q}_{N_T1} & \cdots & \mathbf{Q}_{N_TN_T} \end{bmatrix}^{-1} \begin{bmatrix} \mathbf{p}_1 \\ \vdots \\ \mathbf{p}_{N_T} \end{bmatrix} \quad (7)$$

with

$$\tilde{\mathbf{g}}_i = (\tilde{g}_i[0], \dots, \tilde{g}_i[M-1])^T \quad (8)$$

$$\mathbf{p}_i = (p_i[0], \dots, p_i[M-1])^T$$

and

$$\mathbf{Q}_{ii'} = \begin{bmatrix} q_{ii'}[0] & \cdots & q_{ii'}[-(M-1)] \\ \vdots & \ddots & \vdots \\ q_{ii'}[M-1] & \cdots & q_{ii'}[0] \end{bmatrix} \quad (9)$$

where \tilde{g}_i is the estimated frequency response between the receiving antenna and the i^{th} transmitting antenna. The matrix elements $q_{ii'}[l]$ and $p_i[l]$ are defined as

$$p_i[l] = \sum_{k=0}^{N-1} r[k] s_i^*[k] W_N^{-kl} \quad (10)$$

and

$$q_{ii'}[l] = \sum_{k=0}^{N-1} s_i[k] s_{i'}^*[k] W_N^{-kl} \quad (11)$$

where “*” denotes complex conjugation. The number of samples, M , used in the estimation is chosen to be equal to, or larger than, the length of the impulse response. Figure 1 gives a schematic view of the estimator.

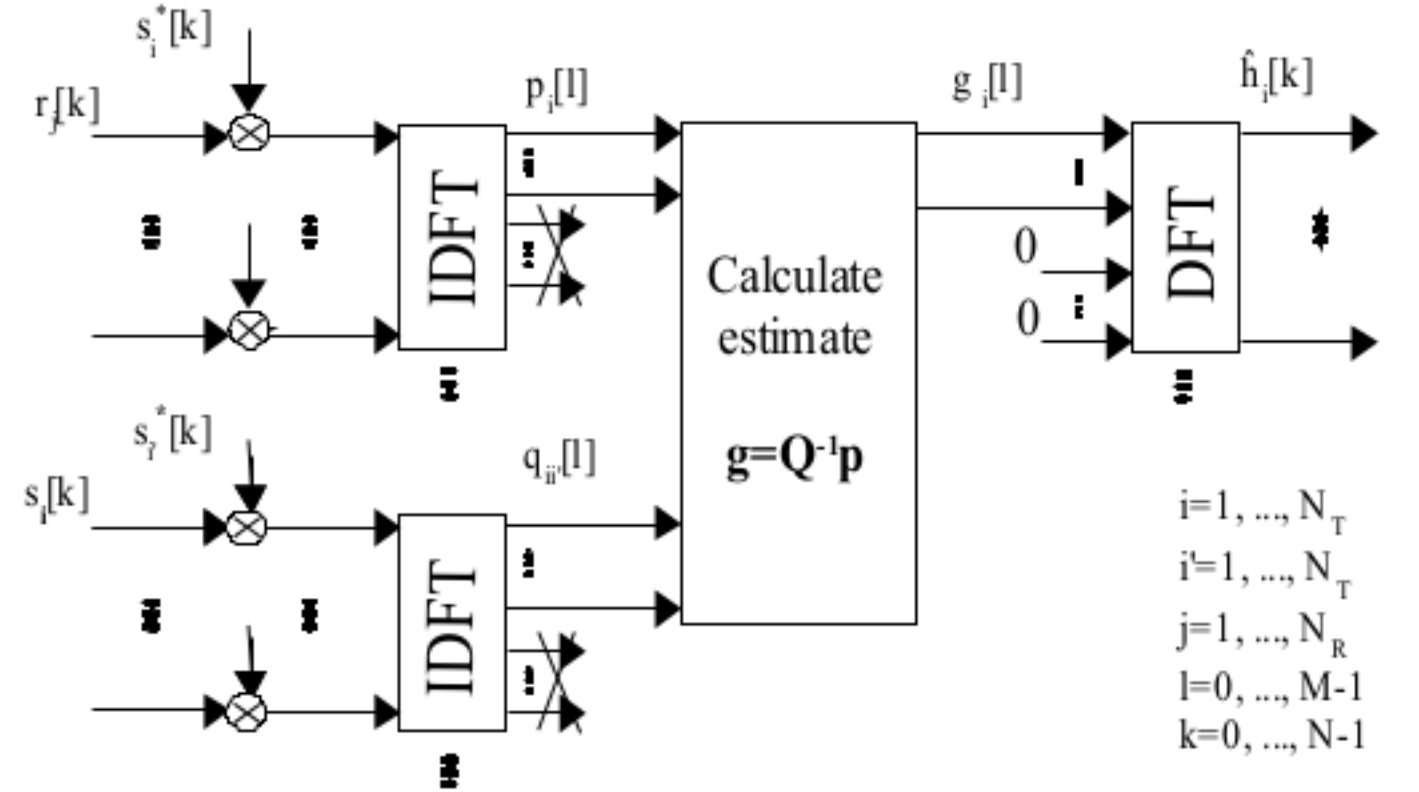

Figure 1: Schematic view of the simplified DFT based LMMSE estimator for MIMO systems.

If training symbols are used the matrix \mathbf{Q} can be computed beforehand and the complexity of the estimator will be $N_R \cdot (2 \cdot \log_2 N + N_T \cdot M^2 / N + 1)$ multiplication's/tone, where N_R and N_T are the number of receiver and transmitter antennas respectively.

Because of the properties of the DFT, there are a few things that need to be emphasized. If the channel is sample spaced (that is, the distance between two multipath components are spaced with integer multiples of the sampling time) the estimator will work perfectly since the DFT will give optimal power concentration [6]. Consequently, the channel energy will be concentrated to the first few samples of the impulse response. If the channel is non-sample spaced, which is more realistic, this will no longer be the case. The IDFT of the sampled frequency response will not be equal to the sampled continuous impulse response, as is the case with a sample spaced channel. This is illustrated in Figure 2 where the channel power of the impulse responses, attained from $\text{IDFT}(h)$ where h is the sampled frequency response, of a sample and non-sample spaced channel are plotted. As can be seen, the energy for the non-sample spaced channel impulse response is not restricted to the first few samples. Instead there is a clearly visible “leakage” of energy to the whole cyclic impulse response. If only the first few samples are used for estimation, the energy in the discarded samples will give rise to an irreducible estimation error.

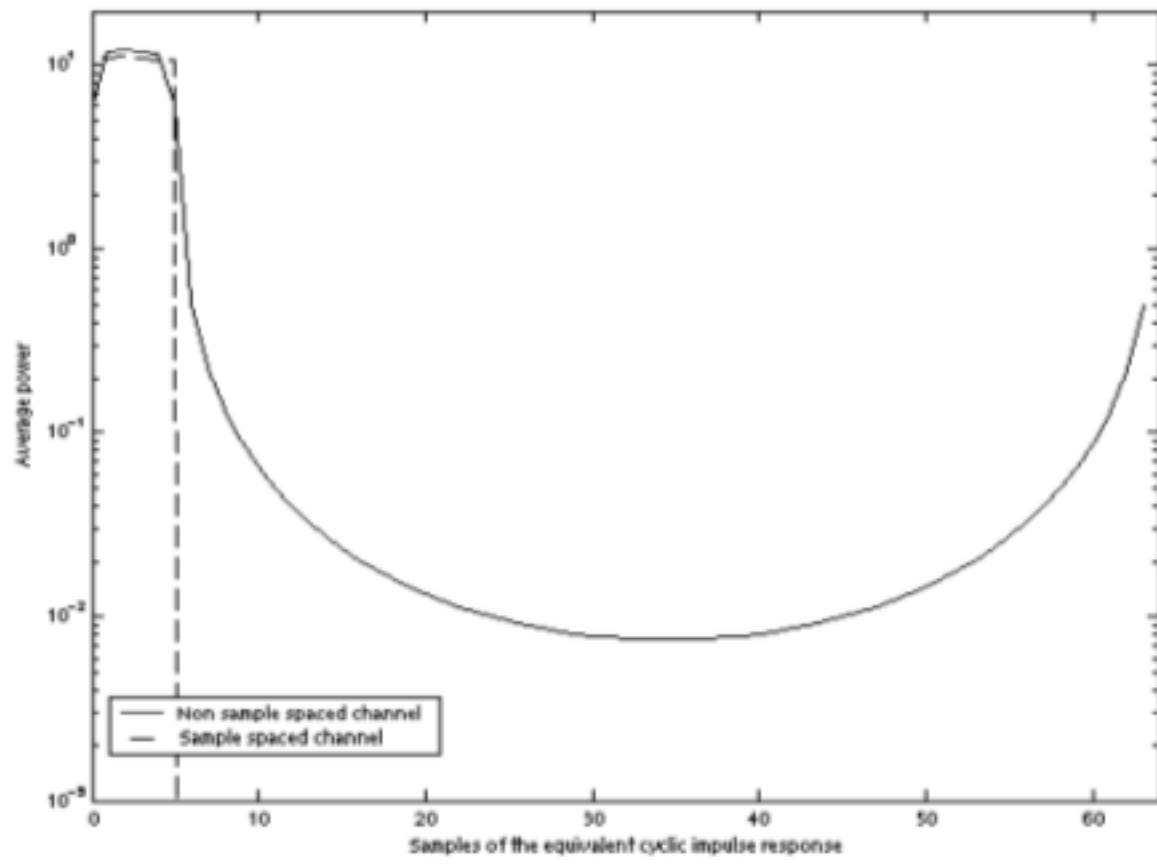

Figure 2: Average power for uniform impulse response for sample spaced and non sample spaced channels.

An alternative estimator based on the one above, which is better suited for non-sample spaced channels, can be derived using channel statistics. This estimator has been presented in [7]. By using the SVD of the auto-correlation of the frequency response, $\mathbf{R}_{hh} = \mathbf{U} \mathbf{\Sigma} \mathbf{U}^H$, an optimal low-rank estimator can be achieved [5]. $\mathbf{\Sigma} = \text{diag}(\lambda_1, \dots, \lambda_N)$, where λ_i are the singular values¹ of \mathbf{R}_{hh} . The matrix \mathbf{U} containing the eigen-vectors, can be used to transform a pre-estimate of the frequency response, e.g. a LS-estimate, to a transform domain where the channel energy is concentrated to the first few samples. In this transform domain a simplified estimator of lower dimension can be used. A nominal \mathbf{R}_{hh} representing the "worst case" uniform power delay profile can be used when designing the estimator, resulting in only a minor mismatch degradation when applying the estimator to channels with other power delay profiles [5]. This allows the transform matrix \mathbf{U} to be pre-calculated.

The simplified SVD based LMMSE estimator is achieved by substituting the Fourier transform, used in the estimator above, with the matrix \mathbf{U} received from the SVD of \mathbf{R}_{hh} . Due to the independent transform coefficients of the new transform, the LMMSE estimation in the transform domain can be done independently on each coefficient by using a weighing factor $\delta_i = \lambda_i / (\lambda_i + \beta / \text{SNR})$. These will compensate for the fact that for small SNR values samples corresponding to small eigen-values will contain more noise than channel energy. The compensation is done by suppressing these samples in the estimation.

By using the transform matrix \mathbf{U} , the matrix elements $q_{ii}[l]$ and $p_i[l]$ in (10) and (11) can be written as

$$p_i[l] = \sum_{k=0}^{N-1} r[k] s_i^*[k] U^*[k, l] \quad (12)$$

and

$$q_{ii}[l] = \sum_{k=0}^{N-1} s_i[k] s_i^*[l] U^*[k, l] \quad (13)$$

¹ Since \mathbf{R}_{hh} is a (square) autocorrelation matrix, the SVD is also an eigen-decomposition.

The estimator, which is presented schematically in Figure 3, is then derived as in the previous section using (7)-(9).

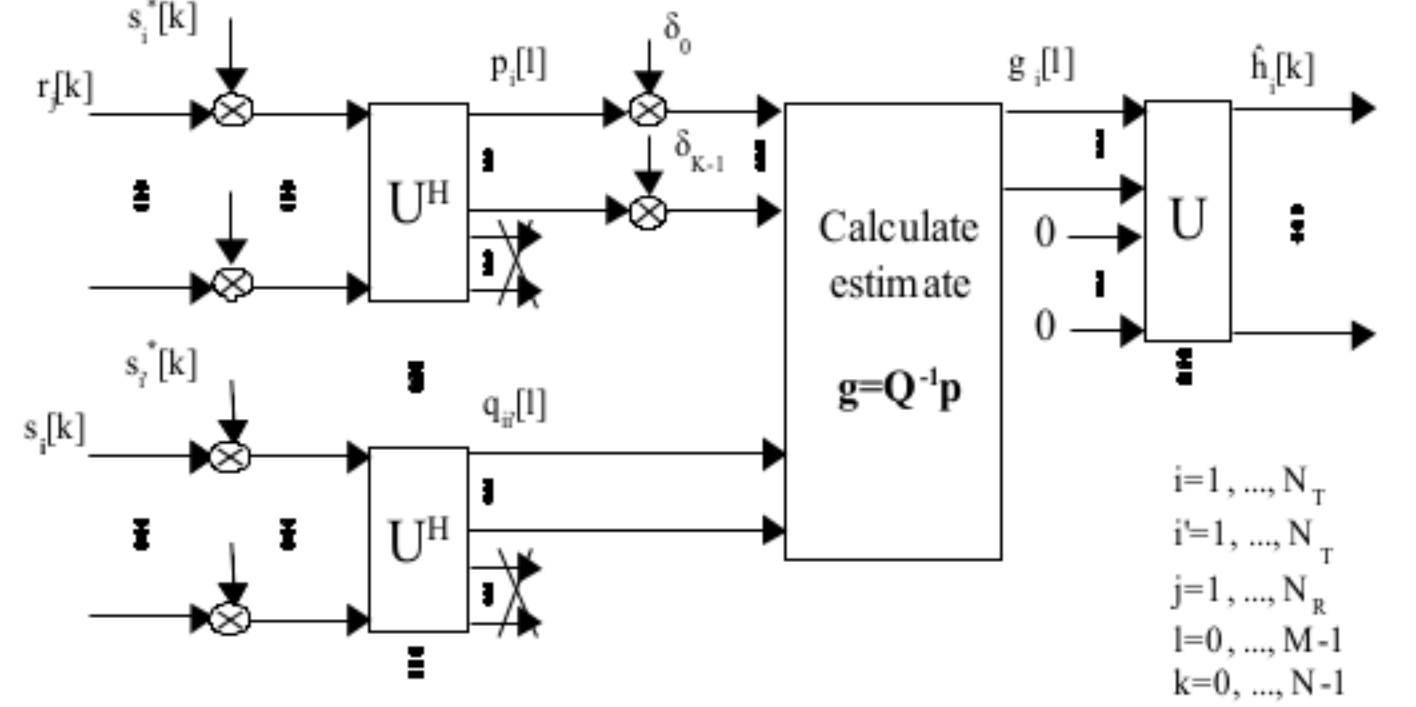

Figure 3: Schematic model of the simplified SVD based LMMSE estimator for MIMO OFDM systems.

The value for the number of channel taps M used in the estimator should be chosen as $M \geq L + 1$, where L the length of the CP [5].

By substituting the DFT by the transform matrix \mathbf{U} , an estimator that is better suited for non-sample spaced channels is achieved. With a better power concentration, less channel energy will be lost when only the first M samples are used in the estimation. The estimation error caused by the discarded channel taps is therefore lowered.

The complexity of the estimator can be expressed as $N_R \cdot (2 \cdot M + N_T \cdot M^2 / N + 1)$ multiplications/tone, where N_R and N_T are the number of receiver and transmitter antennas respectively.

V. SIMULATION RESULTS

The two transform based estimators for MIMO OFDM are studied for a 2×2 antenna system. The number of OFDM sub-channels are set to $N=64$ and the length of the cyclic prefix to $L=6$, equal to the lengths of the impulse response. Both uniform and exponentially decaying power delay profiles are used. The number of channel taps are set to $R=100$ for the case of non-sample spaced channel and to $R=L$ for the case of sample spaced channel². BPSK is used as the modulation format.

The two estimators are studied for a few different cases, starting with an evaluation of the DFT based estimator in a sample spaced and a non-sample spaced uniform channel using, $M=L$ samples in the estimation.

² For the sample spaced case, there are only L sample spaced delay positions within the cyclic prefix and it is therefore not necessary to use more than L taps in the model.

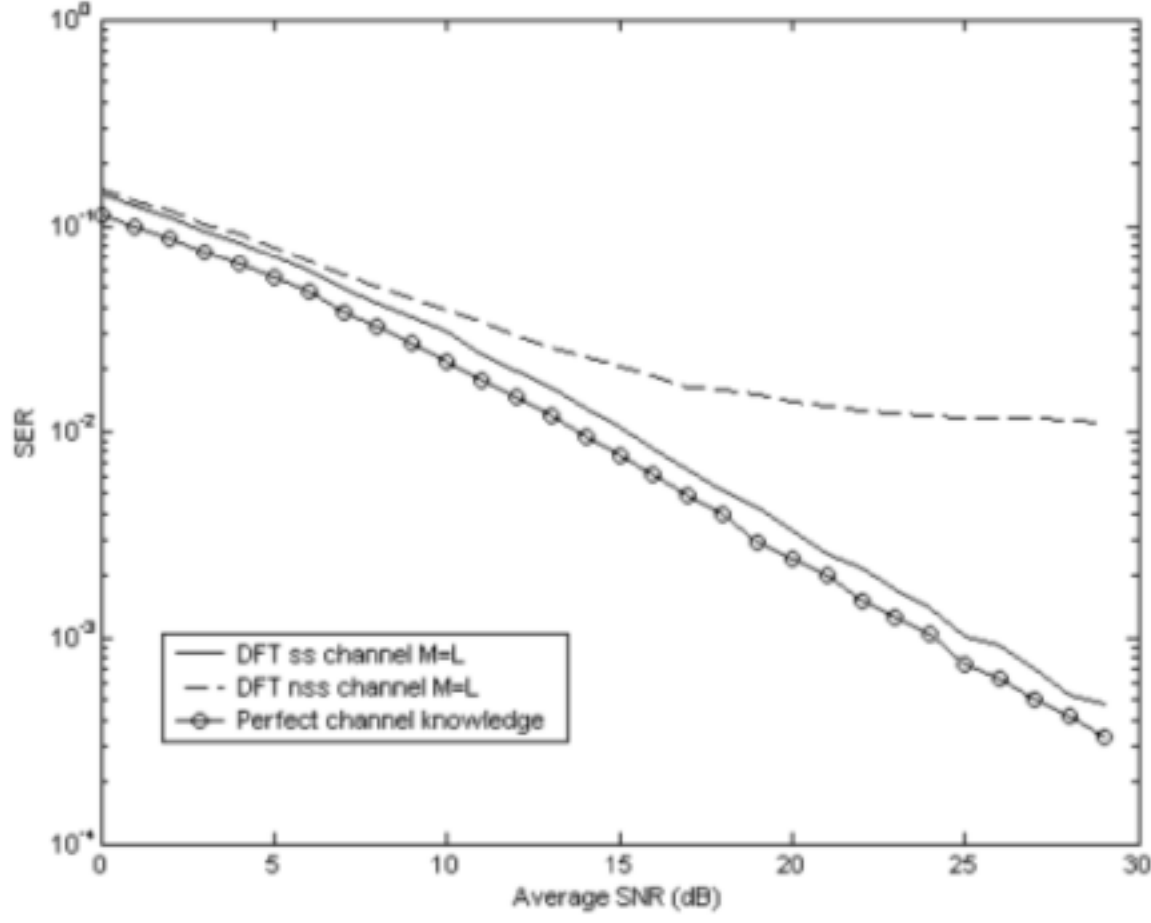

Figure 4: Comparison between the performance of the DFT based estimator in sample spaced channel and non sample spaced channels.

As can be seen in Figure 4, where the symbol error rate (SER) is plotted, the DFT estimator performs perfectly in the case of a simple sample spaced channel. But when used in a non-sample spaced channel it experiences a quite severe error floor. This floor is caused by the energy that is lost in the $N-M$ excluded coefficients.

Next the DFT and SVD based estimators are compared. To illustrate the performance of the estimators for different number of channel taps used in the estimation two different values of M were used. $M=L$ and $M=L+3$. In Figure 5 the SERs of the two estimators are presented for the case of a uniform power delay profile.

As expected, the DFT based estimators experience an error floor caused by the channel energy in the excluded coefficients. By adding more channel taps in the estimation process the error floor is slightly lowered, but the improvement is not that large.

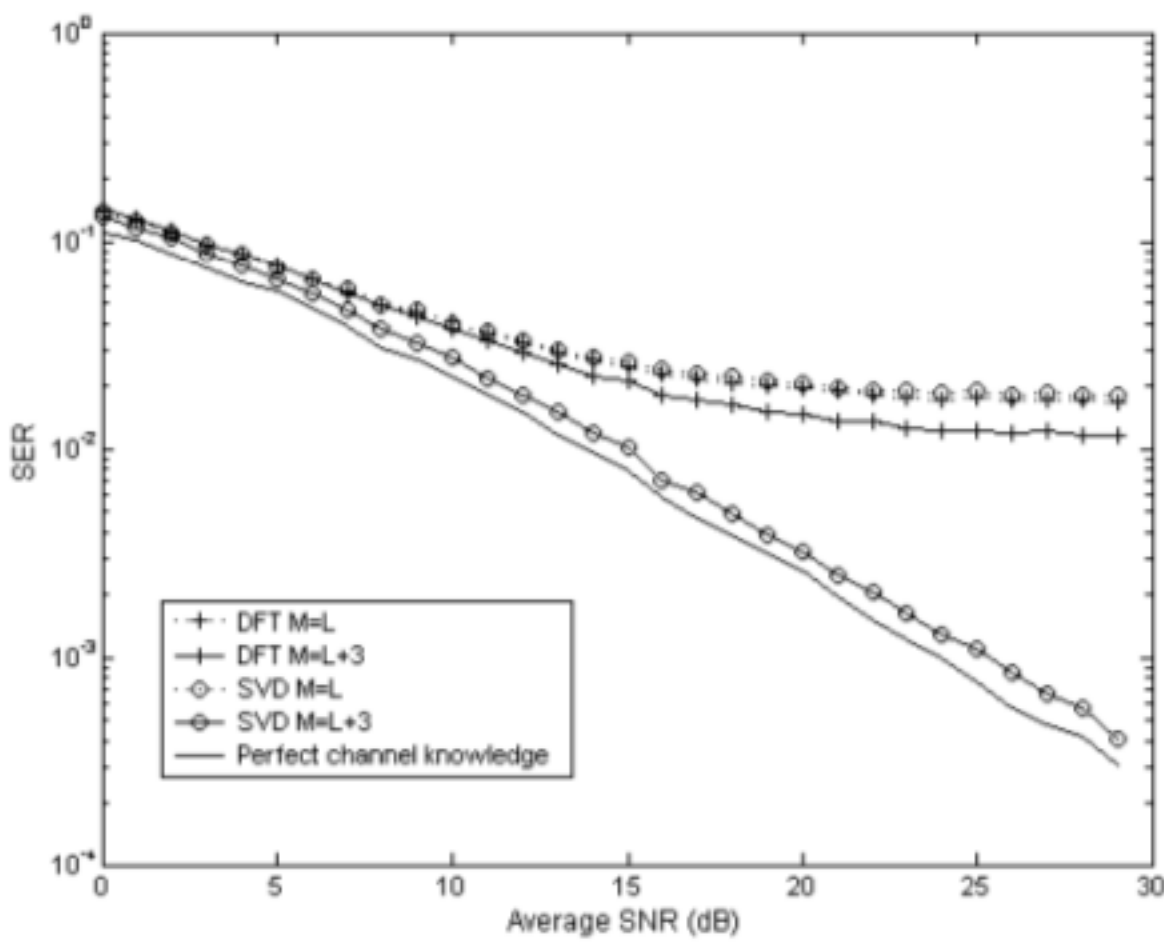

Figure 5: Comparison between DFT and SVD based estimators in a non sample spaced channel with uniform power delay profile

If the attention is turned over to the SVD based estimator it is seen that the performance is much better. An error floor is present for the SVD based estimator using $M=L$ coefficients,

much similar to the one experienced with the DFT based estimator, but by adding a few more coefficients in the estimation the performance is greatly improved. For $M=L+3$ there is no error floor present below SNR levels of 30 dB.

In Figure 6 the SER of the two estimators are presented for the case of an exponentially decaying power delay profile. The decay factor was set to 25% of the length of the impulse response, i.e. $\tau_{rms}=0.25 \cdot L \cdot T_s$.

The performance of the SVD based estimator is in this case much better than for the DFT based. Both the two DFT based estimators, along with the SVD based estimator using $M=L$ coefficients in the estimation, will have an error floor visible from about 10-15 dB SNR. But since the SVD based transform gives a better power concentration than the DFT, the performance of this estimator is better.

By using more coefficients in the estimation the performance gain is negligible for the DFT based estimator, while it is significant for the SVD based estimator. Because of the cyclic property of the DFT, most of the channel energy leakage will in this case be "around the corner" to the end of the cyclic impulse response [6]. By including these coefficients the performance can be improved, but this is beyond the scope of

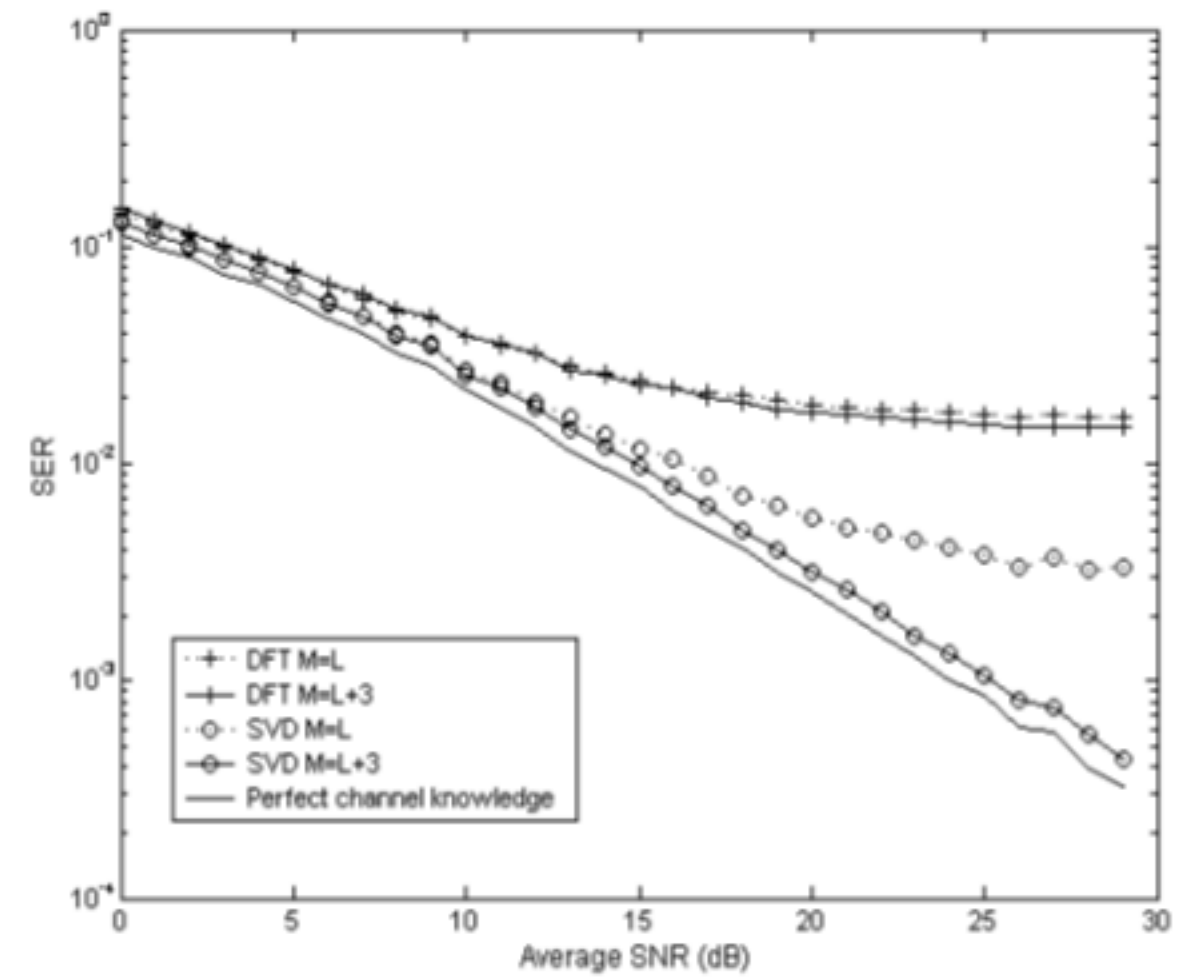

Figure 6: Comparison between DFT and SVD based estimators in a non sample spaced channel with exponentially decaying power delay profile

VI. CONCLUSIONS

A comparison between two transform based estimators for MIMO OFDM has been performed. One using a DFT and one using an SVD based transform. It has been shown that the SVD based estimator will perform better due to better power concentration of the impulse response. It has also been shown that the performance of the DFT based estimator is dependent of the channel model used. For a simple sample spaced model the DFT will give perfect power concentration and excellent performance. However, in more realistic channels there will be an error floor present at high SNR levels. For systems designed to work at these levels this is of special concern since it will have a big impact on the overall system performance. It is therefore important that an appropriate channel model is used in computer simulations.

The number of channel taps used in the estimators will have a direct impact on the size of the estimation error. For the DFT based estimator the minimum number of taps used should be the same as the length of the impulse response. Using more taps in the estimation will only cause a small reduction of the estimation error. Since the complexity of the DFT based estimator only grows slowly with the number of taps used, it could be worth adding a few extra taps.

For the SVD based estimator it is shown that by using a few extra taps in the estimation, the estimation error will be greatly reduced. Since the complexity of the estimator grows linearly with the number of channel taps used, it is important to keep the number down. The simulations verified the result from [5], stating that the number of taps that should be used in the SVD based estimator is at least one more than the length of the impulse response (measured in samples).

REFERENCES

- [1] G.L. Stuber, J.R. Barry, S.W. Mclaughlin, Y.G. Li, M.A. Ingram, T.G. Pratt, "Broadband MIMO-OFDM Wireless Communications," *Proceedings of the IEEE*, vol. 92, 2, pp. 271-294, Feb. 2004.
- [2] A. Molisch, *Wireless Communications*, Wiley, 2005.
- [3] Y. (G.) Li, N. Seshadri, and S. Ariyavisitakul, "Channel Estimation for OFDM Systems with Transmitter Diversity in Mobile Wireless Channels", *IEEE Journals on Selected Areas in Communication*, vol. 17, 3, pp. 461-471, March 1999.
- [4] Y. Gong, K. B. Letaief, "Low Complexity Channel Estimation for Space-Time Coded Wideband OFDM Systems", *IEEE Transactions on Wireless Communications*, vol. 2, 5, pp. 876-882, Sept 2003.
- [5] O. Edfors, M. Sandell, J.-J. van de Beek, S. K. Wilson and P.O. Börjesson, "OFDM Channel Estimation by Singular Value Decomposition", *IEEE Transactions on Communications*, vol. 47, 7, pp. 931-939, July 1998.
- [6] O. Edfors, M. Sandell, J.-J. van de Beek, S. K. Wilson, P.O. Börjesson, "Analysis of DFT-based Channel Estimators for OFDM", *Wireless Personal Communications*, vol. 12, 1, pp. 55-70, 2000.
- [7] P. Hammarberg, "Transform Based Channel Estimation for MIMO OFDM Systems", Masters thesis, Lund University, 2005.
- [8] O. Edfors, M. Sandell, J.-J. van de Beek, D. Landström, and F. Sjöberg. "An introduction to Orthogonal Frequency-Division Multiplexing", *Research Report TULEA 1996:16*, Div. of Signal Processing, Luleå University of Technology, Luleå, Sept. 1996.