



# LUND UNIVERSITY

## Algorithm and Hardware Aspects of Pre-coding in Massive MIMO Systems

Prabhu, Hemanth; Rodrigues, Joachim; Liu, Liang; Edfors, Ove

*Published in:*

2015 49th Asilomar Conference on Signals, Systems and Computers

*DOI:*

[10.1109/ACSSC.2015.7421319](https://doi.org/10.1109/ACSSC.2015.7421319)

2015

[Link to publication](#)

*Citation for published version (APA):*

Prabhu, H., Rodrigues, J., Liu, L., & Edfors, O. (2015). Algorithm and Hardware Aspects of Pre-coding in Massive MIMO Systems. In *2015 49th Asilomar Conference on Signals, Systems and Computers* (pp. 1144-1148). IEEE - Institute of Electrical and Electronics Engineers Inc..  
<https://doi.org/10.1109/ACSSC.2015.7421319>

*Total number of authors:*

4

### General rights

Unless other specific re-use rights are stated the following general rights apply:

Copyright and moral rights for the publications made accessible in the public portal are retained by the authors and/or other copyright owners and it is a condition of accessing publications that users recognise and abide by the legal requirements associated with these rights.

- Users may download and print one copy of any publication from the public portal for the purpose of private study or research.
- You may not further distribute the material or use it for any profit-making activity or commercial gain
- You may freely distribute the URL identifying the publication in the public portal

Read more about Creative commons licenses: <https://creativecommons.org/licenses/>

### Take down policy

If you believe that this document breaches copyright please contact us providing details, and we will remove access to the work immediately and investigate your claim.

LUND UNIVERSITY

PO Box 117  
221 00 Lund  
+46 46-222 00 00



# Algorithm and Hardware Aspects of Pre-coding in Massive MIMO Systems

Hemanth Prabhu, Joachim Rodrigues, Liang Liu, and Ove Edfors  
Department of Electrical and Information Technology, Lund University, Sweden  
{Hemanth.Prabhu, Joachim.Rodrigues, Liang.Liu, Ove.Edfors,}@eit.lth.se

**Abstract**—Massive Multiple-Input Multiple-Output (MIMO) systems have been shown to improve both spectral and energy efficiency one or more orders of magnitude by efficiently exploiting the spatial domain. Low-cost RF chains can be employed to reduce the Base Station (BS) cost, however this may require additional baseband processing to handle induced distortions due to the hardware impairments. In this article the reduction of Peak-to-Average power Ratio (PAR) of the transmitted signals and IQ imbalance in the mixer are analyzed for the down-link. We analyze various pre-coding schemes and estimate the required processing energy per transmitted information bit. Simulation on gate-level show that the energy cost of performing pre-coding and tackling of hardware impairments range from very low to reasonable, compared to the processing necessary in a system without impairments.

## I. INTRODUCTION

Massive Multiple-Input Multiple-Output (MIMO) is a promising technology to meet the ever increasing data-rate demand in the next-generation wireless communication systems. Massive MIMO are systems wherein the Base Stations (BSs) are equipped with a very large number of antennas, compared to previously considered systems, simultaneously serving a relatively low number of users in the same frequency and time resource. The advantages of massive numbers of antennas at the BS is well studied in literature [1] and also backed by measurement campaigns [2].

With a massive number of antennas, low-cost Radio Frequency (RF) chains are needed to reduce the BS cost. Fortunately, to achieve massive MIMO gains we do not require high precision hardware. In fact, much lower hardware precision is required than in traditional systems. In [3], most of the hardware impairments are shown to cause an additive distortion that is substantially uncorrelated with the desired signals and, hence, vanish asymptotically with an increasing number of antennas. For a practical massive MIMO system with a limited number of antennas, effects of hardware impairments like IQ imbalance will not completely disappear. Also, highly linear Power Amplifiers (PAs) are inefficient and consume more power than those with lower requirements on linearity. It is therefore of interest to reduce the Peak-to-Average power Ratio (PAR) of transmitted signals to be able to use more efficient PAs without causing in-band and out-of-band distortions.

In this study two approaches of tackling PAR are compared *i.e.*, a single-carrier discrete-time constant envelope (CE) modulation and an OFDM-based antenna reservation

technique. The CE pre-coding has stringent constraints on amplitude and utilizes the high degree-of-freedom available in massive MIMO systems to provide 0dB PAR in the discrete-time domain. Conversion to continuous-time will increase the PAR, but leave it at a tolerable level. The antenna reservation technique is based on Zero-Forcing (ZF) and OFDM modulation, and adds a 15% complexity overhead. Also, in this paper the effects of IQ imbalance in massive MIMO and its pre-compensation are described. To compare these different techniques we have implemented and estimated their energy consumption per information bit. In the next section, the massive MIMO system model is described followed by a description of a QR-Decomposition based ZF pre-coder. In Sec.IV analysis of PAR aware pre-coding schemes are described. Followed by description of effects of IQ imbalance and corresponding low cost pre-compensation technique. Finally in Sec.VI a comparison of all the aforementioned schemes are performed in-terms of energy-per-(information)-bit.

## II. SYSTEM MODEL

The system model and the pre-coding in this section is in line with the corresponding description in [1]. Let  $M$  be the number of antennas at the BS and  $K$  the number of single antenna users. The channel matrix to all users at the  $n$ -th tone is denoted as  $\mathbf{H}_n \in \mathbb{C}^{K \times M}$ , and the subscript is dropped when a single-carrier system is considered. Let  $\mathbf{x}_n = [x_{1,n}, x_{2,n}, \dots, x_{M,n}]^T$  denote the transmitted vector from the  $M$  BS antennas, which is normalized to satisfy  $\mathbb{E}[\mathbf{x}_n^H \mathbf{x}_n] = 1$ , and  $()^H$  is the Hermitian transpose. The overall symbol vector received by the  $K$  autonomous users is

$$\mathbf{y}_n = \sqrt{\frac{P_T}{M}} \mathbf{H}_n \mathbf{x}_n + \mathbf{w}_n, \quad (1)$$

where  $P_T$  is the total transmit power, and  $\mathbf{w}_n$  is a  $K \times 1$  vector i.i.d complex Gaussian variables with variance  $\sigma^2 \mathbf{I}_{K \times K}$ .

To fully exploit a large antenna array, the user symbols/information at the BS needs to be translated or mapped to correct signals in the antennas, so that each user receives the information with low (zero) interference from signals intended for other users. For linear precoding schemes, this mapping is expressed as

$$\mathbf{x}_n = \mathbf{F}_n \mathbf{s}_n, \quad (2)$$

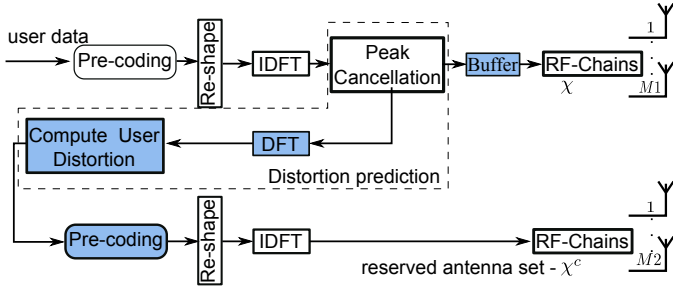

Figure 1. Data-flow illustration of the low complexity PAR reduction approach, where the dedicated set of compensation antennas  $\chi^c$  counteracts the clipping based distortion.

where  $s_n$  is a  $K \times 1$  vector containing the symbols intended for the  $K$  users on  $n$ -th tone, and  $F_n$  is the  $M \times K$  pre-coding matrix mapping user symbols to antenna signals  $x_n$ . Two well known linear pre-coding schemes in massive MIMO are, Matched Filter (MF) and ZF, with  $F_{MF} \propto H^H$  and  $F_{ZF} \propto H^H(HH^H)^{-1}$ , respectively [4]. The ZF pre-coder is basically a constrained least-squares solution for an under-determined system, *i.e.*, ZF cancels all inter-user interference with least transmit energy ( $\min \|x\|_2$ , subject to  $s = Hx$ ).

### III. QRD BASED ZF PRE-CODER

The processing of the QR based ZF pre-coder is split into four parts, namely, matrix multiplication ( $H^H$  same as in MF), generation of a Gram matrix ( $HH^H$ ), performing a QR-decomposition, and applying the corresponding solver. The Hermitian matrix multiplication is processed per-antenna, and each instance implements a simple vector-dot-product based on Multiply-Accumulate (MAC) units. For the Gram matrix generation the computational complexity is  $\mathcal{O}(\frac{1}{2}MK^2)$ , and implemented using a triangular systolic array [5].

There are plethora of highly optimized QR decomposition implementations in traditional MIMO systems. Unfortunately, scaling-up these implementations for massive MIMO is quite expensive in terms of hardware. However, under favourable conditions and high ratios between antennas at BS and Mobile Station (MS) ( $\beta$ ),  $Z$  becomes diagonally dominant. This property is also extensively used in [4] as an initial condition for Neumann series. In case of a QR decomposition the diagonal dominance eases the computations resulting in a complexity  $\mathcal{O}(K^2(K-1) + 3K)$ , around 50% lower than for traditional QR algorithms.

After the QR decomposition, the user data is precoded by performing  $R^{-1}Q^H$  implicitly. This computation is performed to reduce hardware cost, and also compared to an explicit computation requires lower latency. The hardware for the pre-coder is implemented in 28 nm FD-SOI technology, and in this paper we use this technology as a reference for power consumption. The power consumption for performing the QR decomposition and running the solver are 29 mW and 26 mW, respectively. In the next section some approaches to lower PAR of transmitted signal and tackling the IQ imbalance in massive MIMO is briefly described. First-off the issue of PAR

is described, which is in-line with previously published articles [6], [7].

### IV. PAR AWARE PRE-CODING

Firstly, the antenna reservation technique based on ZF and Orthogonal Frequency-Division Multiplexing (OFDM) modulation is described. This is followed by narrow band discrete-time constant envelope pre-coder.

#### A. Antenna Reservation based on ZF

Clipping in the digital domain is a very simple technique to reduce PAR, but suffers from in-band distortion. An approach to compensate this in-band (not including the guard-band) distortion is to dedicate a subset of the antennas which transmits signals used to mitigate the resulting distortion. This technique adheres with the availability of large number of antennas in massive MIMO, and is coined as "antennas reservation" similar to the "tone-reservation" in an OFDM system. Unlike reserving tones in OFDM, which lowers capacity linearly, reserving antennas reduces capacity logarithmically.

Fig. 1 describes the top-level data flow, with additional modules (shaded) required to perform distortion mitigation. For a system with  $M = 100$  antennas, where  $M2 = 20$  are reserved, about 4 dB of PAR improvement is achieved, with about 15% complexity overhead compared to a system without antenna reservation [6].

#### B. Discrete-Time Constant Envelope pre-coder

To employ a highly efficient non-linear PA, a very strict constraint on the amplitude of the transmitted signal is enforced, resulting in nearly 0 dB PAR. This strict amplitude constraint downlink transmission scheme is known as "discrete-time constant envelope". The information is carried on the phase and exploits the large degree of freedom available in massive MIMO to provide high sum-rates [8].

The CE pre-coder can be viewed similar to ZF [7], *i.e.*, suppression of inter-user interference, but with an additional constraint on the amplitude as

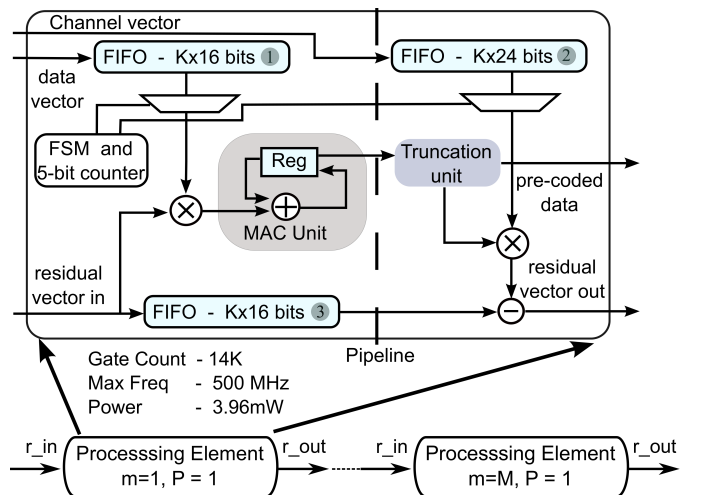

Figure 2. Systolic array for CE pre-coder based on coordinate-descent algorithm, where each processing element solves phase for an antenna.

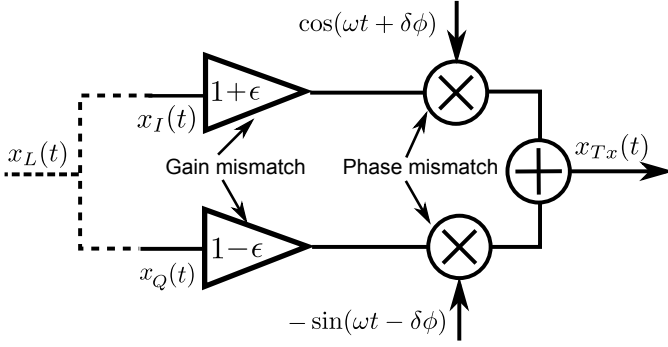

Figure 3. Transmitter IQ imbalance model, with  $\epsilon$  and  $\delta\phi$  the physical mismatch parameters,  $x_L(t)$  time domain baseband IQ signal and  $x_{Tx}(t)$  is transmitted signal.

$$\begin{aligned} & \underset{\mathbf{x}}{\text{minimize}} \quad \|\mathbf{s} - \mathbf{H}\mathbf{x}\|_2 \\ & \text{subject to} \quad |x_m|^2 = 1, \text{ where } m = 1, \dots, M. \end{aligned} \quad (3)$$

The solution of (3) has multiple local-minima, but in a massive MIMO system, even the local minima tend to be close to optimal. To solve the CE pre-coder the coordinate-descent algorithm is employed, which is similar to gradient-descent, barring that the optimization is performed on one coordinate (variable) at a time. The complexity is  $\mathcal{O}((9K + 5)MP)$ , where  $P$  is the number of iterations. It should be noted that this is valid for a single tap (narrow-band) channel. For wide-band channels we expect the complexity to scale linearly with the number of channel taps.

The proposed optimization is very suitable for a systolic array implementation, where each processing element computes the phase for an antenna see Fig. 2. The processing element needs to store the channel vector of the corresponding antenna. After computing the phase the residual vector is streamed to the next processing element for computation. Each element takes 14.1 K gates and the hardware cost scales linearly with the number of antennas and iterations.

## V. IQ IMBALANCE PRE-COMPENSATION

Direct-conversion transceivers have an in-phase (I branch) and quadrature (Q-branch) which are passed through two mixers with a phase difference of  $90^\circ$ . IQ imbalance arises when there is a mismatch in amplitude or phase between the mixers. This effect can be modeled by two parameters, *i.e.*,  $\epsilon$  amplitude and  $\delta\phi$  phase mismatch, as shown in Fig. 3. The effects and compensation of IQ imbalance is well studied [9], [10]. In-line with these works, we define two variables,  $a$  and  $b$ , which are calculated from the physical parameters as

$$\begin{aligned} a &= \cos(\delta\phi) + j\epsilon \sin(\delta\phi) \\ b &= \epsilon \cos(\delta\phi) + j \sin(\delta\phi), \end{aligned} \quad (4)$$

where  $a \rightarrow 1$  and  $b \rightarrow 0$  with decreasing  $\epsilon$  and  $\delta\phi$ . The signal received at a perfect receiver when there is frequency independent IQ imbalance at a transmitter, becomes

$$x_{Rx}(t) = ax_{Tx}(t) + bx_{Tx}^*(t), \quad (5)$$

which, in the corresponding frequency domain is expressed as

$$X_{Rx}(f) = ax_{Tx}(f) + bx_{Tx}^*(-f), \quad (6)$$

indicating a dual effect. There is both an attenuation of the correct signal and interference from a frequency mirrored copy of the signal.

Various studies on the effects of hardware impairments for massive MIMO systems were performed [3], [10], however, these do not consider any hardware cost. In the following section an analysis of IQ imbalance in the downlink is performed, which show that there is a need for pre-compensation.

### A. Effects of IQ imbalance in massive MIMO

To evaluate the effects of IQ imbalance, we look at the Signal-to-noise-plus-distortion ratio (SNDR) at the user terminals

$$\text{SNDR} = 10 \log_{10} \left( \frac{P_s}{P_d + \sigma_w^2} \right), \quad (7)$$

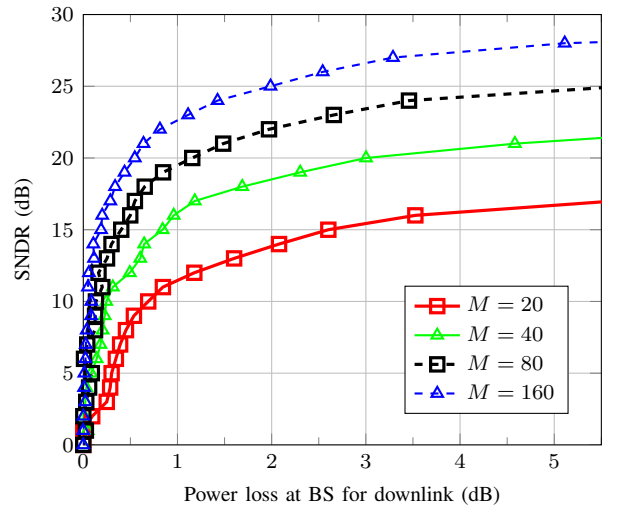

Figure 4. Simulated IQ imbalance for  $K = 10$  users massive MIMO system with 6% amplitude and  $6^\circ$  degree phase mismatch.

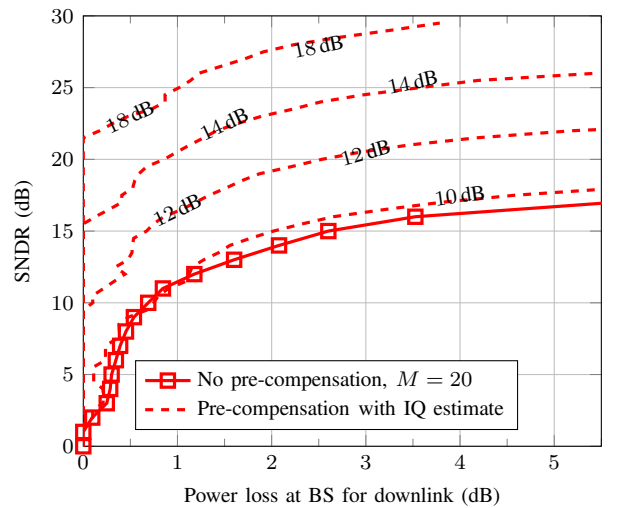

Figure 5. Pre-compensation for  $M = 20$ ,  $K = 10$  system, with different IQ imbalance estimation accuracy.

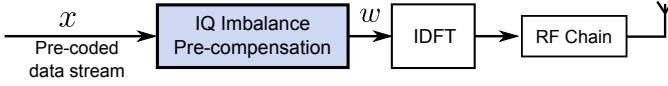

Figure 6. IQ imbalance pre-compensation top level data flow.

where  $P_s$  is the signal strength,  $P_d$  is the distortion due to IQ imbalance at the transmitter and  $\sigma_w^2$  is the additive noise variance at the receiver. For a fixed transmission power budget, signal power increases linearly with the number of antennas, due to the array gain. However, the IQ distortion increases at a much slower rate, mainly due the fact that the phase of distortion is negated ( $x_{Tx}^*$  in (5)), and rotated (multiplying by  $b$ ). Hence, the IQ distortion is unlikely to add-up constructively at the receiver. This effect can be seen in Fig. 4, where the x-axis is the loss in power compared to a system with no IQ imbalance. For a fixed configuration, the SNDR will saturate if the distortion dominates over noise, and further increasing transmission power has very little effect on the SNDR. One way to improve the SNDR is to increase the number of antennas, as seen in Fig. 4. The improvement is, however, rather limited and digital pre-compensation may be a better option to limit this particular effect.

### B. Pre-compensation architecture

Increasing the number of antennas is a robust approach to tackle IQ imbalance, since no knowledge of the IQ imbalance parameters is required. However, increasing the number of antennas only for this purpose may not be the most cost effective. In Fig. 5 we show how the achieved SNDR of  $M = 20$  antennas system increases with digital pre-compensation and different quality of the estimated IQ imbalance parameters. Drastic improvements are achieved for fairly low estimation accuracies and low-energy digital pre-compensation can be a very viable alternative.

The IQ imbalance pre-compensation is performed after pre-

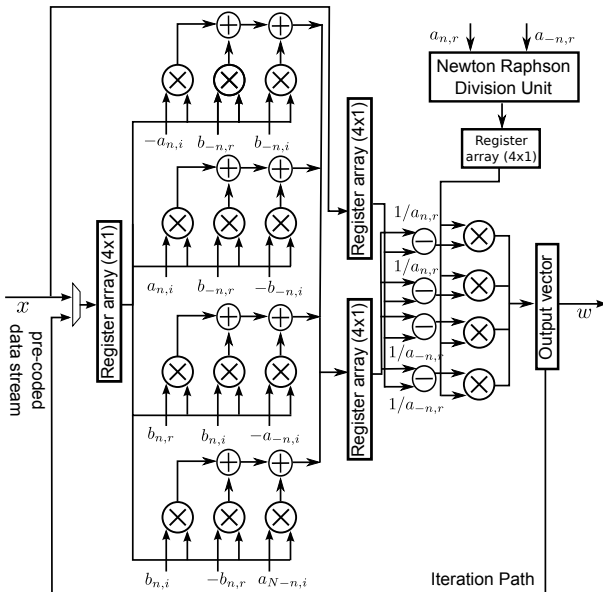

Figure 7. Hardware architecture of pre-compensation based on Jacobi solver.

Table I  
HARDWARE RESULTS FOR IQ IMBALANCE PRE-COMPENSATION IN 28 NM FD-SOI TECHNOLOGY.

	Per Instance	For $M = 100$
Area [mm <sup>2</sup> ] <sup>#</sup>	.008	0.8
Gate Count [10 <sup>3</sup> ]	27	2700
Max. Clock [MHz]	200	200
Latency <sup>*</sup> [cycles]	2	2
Power [mW]	0.6	60

<sup>#</sup> Only synthesis

<sup>\*</sup> Latency is for 1 pair of tones per iteration.

coding as shown in Fig. 6. The main idea of pre-compensation is to transmit the signal  $w$  such that after the mixer with IQ imbalance the transmitted signal is the desired signal  $x$ . As described in (6), mirroring effects the  $n$ -th and  $-n$ -th tone, which needs to be considered during pre-compensation. We therefore group the two sets of linear equations, and express them in the real domain as

$$\begin{pmatrix} a_r^n & -a_i^n & b_r^{-n} & b_i^{-n} \\ a_i^n & a_r^n & b_i^{-n} & -b_r^{-n} \\ b_r^n & b_i^n & a_r^{-n} & -a_i^{-n} \\ b_i^n & -b_r^n & a_i^{-n} & a_r^{-n} \end{pmatrix} \begin{pmatrix} w_r^n \\ w_i^n \\ w_r^{-n} \\ w_i^{-n} \end{pmatrix} = \begin{pmatrix} x_r^n \\ x_i^n \\ x_r^{-n} \\ x_i^{-n} \end{pmatrix}, \quad (8)$$

where the subscripts  $r, i$  indicate real and imaginary parts of complex signals.

The pre-compensation scheme basically involves solving (8). One technique is to perform a brute force inversion and a matrix vector multiplication. However, since  $a$  and  $b$  are close to 1 and 0, respectively, an iterative method of solving linear equations is favorable. This approach is more hardware friendly and Fig. 7 shows a Jacobi iterative approach [11]. To illustrate Fig. 7, we define the  $4 \times 4$  matrix in (8) as  $A$ , the  $4 \times 1$  vectors  $w$  and  $x$ . The matrix  $A$  is split into two matrices  $A = D + R$ , where  $D$  contains only diagonal elements of  $A$ . The initial value of  $w$  is set with values of  $x$ . The 12 multipliers in Fig. 7 are used to perform matrix vector ( $Rw$ ) multiplications. The resulting vector is subtracted with input vector using 4 subtracters ( $x - Rw$ ). The residual vector is then divided by the diagonal elements *i.e.*,  $D^{-1}(x - Rw)$ . Division is performed when updating the estimates by using Newton-Raphson method [13] and 4 multipliers. The hardware has a flexible iterative path, and the input vector are loaded with the residual vector for the next iterations. For a low IQ mismatch parameters, the numerical accuracy of the solver is around 27 dB and 38 dB with just one and two iteration respectively. The pre-compensation was implemented in 28nm FD-SOI technology and the power simulations are performed on a gate level netlist with back annotated timing and toggle information. The corresponding hardware results are shown in Table I. In the next section a comparison of all the aforementioned techniques to perform pre-coding and tackling of hardware impairment are compared.

### VI. ANALYSIS OF PROCESSING ENERGY-PER-BIT

To perform a fair comparison of all the different techniques we estimate the required processing energy per transmitted

Table II  
ENERGY-PER-BIT COMPARISON FOR DIFFERENT PRE-CODING TECHNIQUES TO TACKLE VARIOUS HARDWARE ASPECTS.

	Gate count [K] <sup>1</sup>	Throughput [MSamples/sec]	Power [mW]	Technology	Energy-per-bit [pJ/bit]@28 nm <sup>3</sup>
Matched Filter pre-coding	3.9	25	0.42	28nm	50
Zero Forcing (regularized) pre-coding	400	31.25	29	28nm	338 <sup>4</sup>
Single-carrier (Narrow band) constant envelope	14.1 <sup>2</sup>	50	3.96	65nm	175
Antenna reservation PAR aware pre-coding based on Zero forcing	-	-	-	-	+15% <sup>5</sup>
IQ imbalance pre-compensation	24	100	0.61	28nm	9
OFDM modulation 2048-FFT [12]	180		117	90nm	243

<sup>1</sup> Per instance cost, depending on throughput rates and implementation, multiple instances will be required.

<sup>2</sup> Require one instance per antenna and iteration.

<sup>3</sup> Energy-per-bit = (Power) \* (28 nm/Tech) \* (1/V<sub>DD</sub>)<sup>2</sup>/(data-rate)

<sup>4</sup> Includes Gram matrix generation and matrix inversion and matched filter, however, updated once every 10 sub-carrier and symbols.

<sup>5</sup> Antenna reservation has 15% more computational complexity compared to OFDM based ZF.

information bit, normalized to 28 nm FD-SOI technology, as shown in Table II. The metric is evaluated for an LTE like 100×10 massive MIMO system with 16-QAM modulation.

The energy-per-bit for matched filtering is around 50pJ/bits, which is the lowest energy consumption among the investigated pre-coding schemes. This is in-line with the computational complexity, since matched filtering only requires one matrix-vector multiplication. Furthermore, the operations are distributed per-antenna, reducing data-shuffling and power consumption of the system bus. Compared to MF, the ZF pre-coding is more complex and has a higher energy consumption. However, the performance of ZF is superior to that of MF for the same number of antennas, due to better inter-user interference suppression.

The discrete-time constant envelope pre-coding has lower energy requirements than ZF. Furthermore, since the PAR is low, extremely efficient PAs can be used. However, the implemented CE is for single-carrier narrow band system. For wideband systems, the computational complexity and energy consumption is expected to increase linearly with the number of taps in the channel. As an example, a LTE like system with FFTs required for OFDM modulation along with ZF, requires a total energy-per-bit of 580pJ (FFT 180pJ/bit + ZF 400pJ/bit). Such an OFDM-based system can handle up to 144 taps, which would result in very high energy consumption for a corresponding single-carrier system with CE pre-coding. An alternative low complexity approach to tackle the PAR issue is to use "antenna reservation" techniques. It is based on ZF in a OFDM system, with a complexity overhead of 15% of the total complexity, which when translated to estimated energy is 667pJ/bit (1.15\*580pJ). This is a reasonable overhead considering that it provides around 4 dB of PAR improvement. The performance improvement due to pre-compensation of IQ imbalance is very high with a relatively low energy consumption.

## VII. CONCLUSION

This paper shows various implementations and estimated energy consumption of key processing blocks for massive MIMO. Several linear and non-linear precoding schemes, with and without reduction of PAR to allow energy efficient PAs,

have been compared. A scheme for IQ imbalance compensation is also analyzed. All comparisons show that digital baseband processing in a 100-antenna massive MIMO system can be done at reasonable energy consumption levels.

## ACKNOWLEDGEMENT

We thank Lund University, DISTRANT funded by SSF and MAMMOET funded by EU's 7-th Framework Programme for providing the opportunity to work on this project.

## REFERENCES

- [1] F. Rusek, D. Persson, B. Lau, E. Larsson, T. Marzetta, O. Edfors, and F. Tufvesson, "Scaling up MIMO: Opportunities and challenges with very large arrays," *IEEE Signal Proc.*, vol. 30, pp. 40–60, Jan. 2013.
- [2] X. Gao, F. Tufvesson, and O. Edfors, "Massive MIMO channels : Measurements and models," in *Asilomar Conference on Signals Systems and Computers*, Nov 2013, pp. 280–284.
- [3] E. Bjornson, J. Hoydis, M. Kountouris, and M. Debbah, "Massive MIMO systems with non-ideal hardware: Energy efficiency, estimation, and capacity limits," *Information Theory, IEEE Transactions on*, vol. 60, no. 11, pp. 7112–7139, Nov 2014.
- [4] H. Prabhu, O. Edfors, J. Rodrigues, L. Liu, and F. Rusek, "Hardware efficient approximative matrix inversion for linear pre-coding in massive MIMO," in *IEEE ISCAS*, June 2014, pp. 1700–1703.
- [5] H. Jagadish and T. Kailath, "A family of new efficient arrays for matrix multiplication," *Computers, IEEE Transactions on*, vol. 38, no. 1, pp. 149–155, Jan 1989.
- [6] H. Prabhu, O. Edfors, J. Rodrigues, L. Liu, and F. Rusek, "A low-complex peak-to-average power reduction scheme for OFDM based massive MIMO systems," in *ISCCSP*, May 2014, pp. 114–117.
- [7] H. Prabhu, F. Rusek, J. Rodrigues, and O. Edfors, "High throughput constant envelope pre-coder for massive MIMO systems," in *IEEE ISCAS*, May 2015, pp. 1502–1505.
- [8] S. Mohammed and E. Larsson, "Constant-envelope multi-user precoding for frequency-selective massive MIMO systems," *Wireless Communications Letters, IEEE*, vol. 2, no. 5, pp. 547–550, Oct 2013.
- [9] J. Tubbx, B. Come, L. Van der Perre, L. Deneire, S. Donnay, and M. Engels, "Compensation of IQ imbalance in OFDM systems," in *IEEE ICC*, vol. 5, May 2003, pp. 3403–3407 vol.5.
- [10] N. Kolomvakis, M. Matthaiou, J. Li, M. Coldrey, and T. Svensson, "Massive MIMO with IQ imbalance: Performance analysis and compensation," in *IEEE ICC*, June 2015, pp. 1703–1709.
- [11] G. Golub and C. Van Loan, *Matrix Computations*. Johns Hopkins University Press, 1996.
- [12] Y. Chen, Y.-C. Tsao, Y.-W. Lin, C.-H. Lin, and C.-Y. Lee, "An indexed-scaling pipelined FFT processor for OFDM-based WPAN applications," *Circuits and Systems II: Express Briefs, IEEE Transactions on*, vol. 55, no. 2, pp. 146–150, Feb 2008.
- [13] I. Koren, *Computer Arithmetic Algorithms, Second Edition: Second Edition*, ser. Ak Peters Series. Peters, 2002.