



# LUND UNIVERSITY

## Carbon Fiber Composite Materials in Modern Day Automotive Production Lines – A Case Study

Petersson, Håkan; Motte, Damien; Bjärnemo, Robert

*Published in:*

Proceedings of the International Mechanical Engineering Congress & Exposition - IMECE'13

*DOI:*

[10.1115/IMECE2013-62272](https://doi.org/10.1115/IMECE2013-62272)

2013

*Document Version:*

Publisher's PDF, also known as Version of record

[Link to publication](#)

*Citation for published version (APA):*

Petersson, H., Motte, D., & Bjärnemo, R. (2013). Carbon Fiber Composite Materials in Modern Day Automotive Production Lines – A Case Study. In *Proceedings of the International Mechanical Engineering Congress & Exposition - IMECE'13* (Vol. 2A, pp. V02AT02A037). Article IMECE2013-62272 American Society Of Mechanical Engineers (ASME). <https://doi.org/10.1115/IMECE2013-62272>

*Total number of authors:*

3

### General rights

Unless other specific re-use rights are stated the following general rights apply:

Copyright and moral rights for the publications made accessible in the public portal are retained by the authors and/or other copyright owners and it is a condition of accessing publications that users recognise and abide by the legal requirements associated with these rights.

- Users may download and print one copy of any publication from the public portal for the purpose of private study or research.
- You may not further distribute the material or use it for any profit-making activity or commercial gain
- You may freely distribute the URL identifying the publication in the public portal

Read more about Creative commons licenses: <https://creativecommons.org/licenses/>

### Take down policy

If you believe that this document breaches copyright please contact us providing details, and we will remove access to the work immediately and investigate your claim.

LUND UNIVERSITY

PO Box 117  
221 00 Lund  
+46 46-222 00 00

**IMECE2013-62272**

## **Carbon Fiber Composite Materials in Modern Day Automotive Production Lines – A Case Study**

**Håkan Petersson**

School of Business and Engineering  
Halmstad University  
P.O. Box 823, SE-301 18 Halmstad  
Sweden  
hakan.petersson@hh.se

**Damien Motte, Robert Bjärnemo**

Division of Machine Design  
Department of Design Sciences LTH  
Lund University  
P.O. Box 118, SE-221 00 Lund  
Sweden

damien.motte@mkon.lth.se, robert.bjarnemo@mkon.lth.se

### **ABSTRACT**

New and innovative production equipment can be developed by introducing lightweight materials in modern day automotive industry production lines. The properties of these new materials are expected to result in improved ergonomics, energy savings, increased flexibility and more robust equipment, which in the end will result in enhanced productivity. Carbon composite materials are one such alternative that has excellent material properties. These properties are well documented, and the market for carbon composite materials is growing in many areas such as commercial aircrafts, sporting goods and wind turbines. However, when studying the use of carbon composite materials for production equipment in the automotive industry, it was found that there were few, if any, such examples.

This paper focuses on innovative ways of making carbon composite materials available for designing automotive industry production equipment by introducing a design and material concept that combines flexibility, relatively low costs and high functionality. By reducing the weight by 60%, it was obvious that the operators were very positive to the new design. But just as important as the improvement of the ergonomic feature, the combination of low weight and material properties resulted in a more robust design and a more stable process of operation. The two main designs (two versions of the steel-based design were constructed) were developed sequentially, making it difficult to compare development costs since knowledge migrated from one project to the next. In this study, the gripper was manufactured in both carbon composite material and steel. The different designs were compared with reference to design costs, functionality, robustness, product costs and ergonomics. The study clearly shows that the

composite material represents a favorable alternative to conventional materials, as the system combines superior properties without significantly increasing the cost of the equipment. This paper describes the approach in detail.

## INTRODUCTION

To meet new demands from industry and from customers, the manufacturer of gripper and lifting device is facing new challenges. Traditionally all grippers and fixture devices for transporting and fixing geometry in Body-in-White (BiW) are made of steel or aluminum or combinations of both, resulting in equipment that is too heavy. A second problem is that when using grippers or fixture devices in production, it occurs that they collide or fall to the ground, which results in time consuming and expensive repairs in the workshop. New and higher tolerances and lighter equipment are desired and this calls for new and lighter materials and a new way of designing them.

This paper therefore focuses on innovative ways of making carbon composite materials available for designing automotive industry production equipment by introducing a design and material concept that combines flexibility, relatively low costs and high functionality.

Traditional materials are easy to use and there is good knowledge about how to build and maintain them. Problems that we are facing with new materials are mainly how to design and to assemble them. Non-metal material cannot be welded together, and bolts require that we have to drill holes in the material. If we use carbon fiber composite, drilling will cut the carbon fiber and weaken the design. Gluing is an alternative for composite materials, but leads in turn to new challenges. For example, delamination after gluing to pieces of composites is a major problem, and tests have shown that delamination is the first and most serious problem to handle. After some tensile tests, it was clear that the glue was stronger than the composite itself. This demands a new design of the joints. To be able to glue composite plates together we had to choose a different path of the assembly, mechanical locking turned out to be best solution.

The paper is outlined as follows. The next section describes some of the mechanical properties of the composite materials that are necessary for the understanding of the industrial case. Next, the development of an enhanced nozzle for injecting glue, as well as the testing and validation of glued joints are presented. This is followed by the industrial case where the development and analysis of the gripper is described and illustrated.

## BACKGROUND (COMPOSITE)

Composite materials, often shortened to composites, are engineered or naturally occurring materials made from two or more constituent materials with significantly different physical

or chemical properties that remain separate and distinct within the finished structure. The most common fiber material is glass fiber. Glass fiber has good mechanical properties (strength and stiffness) and low price. Typical products are recreational boats, tanks, bodies, tubes, etc. For more advanced applications glass fiber is often replaced by the more expensive carbon or aramid fiber. These provide increased stiffness and strength, and with aramid an increased affect strength. Some mechanical properties of the carbon fiber material are specified in Table 1. Typical products of these fibers are applications in defense, aerospace (aircraft, satellites), and various types of sports equipment [1].

Normally aluminum and steel are used as materials for building grippers. Employing carbon fiber composites provides two major advantages: 1) The thermal expansion is much lower than that of metals; 2) Carbon fiber composites have great stiffness and do not have any residual deformation as do metals. This is a major advantage because grippers can collide with objects in their surroundings; when they are made of metal, they must undergo calibration before they can be used. Carbon fiber is linear to failure, and if it does not fail, it can be used without any calibrations.

Carbon fiber composites are built up by using a thin carbon fiber. The fiber is woven into a mat with the pattern of fibers and directions of fibers according to the application in which it is to be used; a completed woven fiber mat is illustrated in Figure 1 [2]. When using it as a composite material it has to be used together with an epoxy-based component (matrix) that is vacuum injected into the fiber mat.

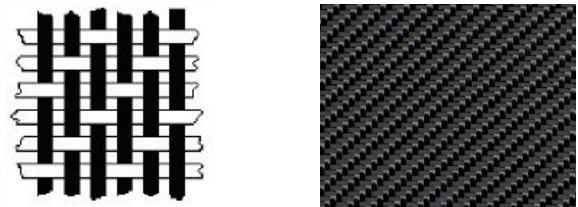

Figure 1. Carbon fiber composite structure. Left: Woven fiber [3, p. 23]. Right: Carbon fiber mat, <https://carbonsales.com>.

Material selection has become more important in many applications. New requirements (low weight, costs, performance etc.) are placed on new material. Fiber composite is not a new material, but applications have changed during the last 10 years. Carbon fiber composite is a further development. It provides enhanced capabilities, it is light, strong and can be built to be strong in the desired direction.

One challenge when using fiber composite in an application is making connections to other materials without damaging the fiber, as the fiber is the core of the composite's strength. For example, cutting the fiber by drilling a hole without securing the fiber results in shearing in the matrix and

the composite loses its mechanical properties. Comparing with [4, pp. 185-88], tests were made with plates [5, pp. 48-59] that showed nearly the same results as the theoretical thesis.

Results from [5, pp. 53-54], show among other things that tensions around the hole can be as high as the unaffected composite plate. For securing the fiber [6], argues that it is preferable to use molded holes, but this requires that the design of the product allow for predefined molded holes. This illustrates the difficulty of using composite materials in products.

Analysis of composite material is difficult for several reasons. First, the structure of the material is complex. Computer based analysis of composites demands both a composite modeler where fiber orientation and properties can be set and tensile tests for verification. Fiber composites are called orthotropic; their behavior lies between isotropic and anisotropic materials, and differences between these materials can be best explained through their responses to tensile and shear load [1, pp. 158-159]. Second, the properties of the material vary greatly with the configuration of the matrix, the composition and proportion of the two included materials and the manufacturing process where the composite material is made under vacuum and there is little control of the composite plate's thickness [7]. It is therefore difficult to achieve an accurate result without performing a tensile test of both the composite plate itself and its connections with the other details of the product.

Such a material model is complex, and it takes experience to interpret the results because stresses in the individual layers with different orientations are generally different in a laminate [3]. It is therefore possible that one layer reaches its limiting stresses before the other layers, resulting in a failure in that layer, generally referred to as first-ply failure. Regarding [3], when analyzing laminates, prediction of the laminate strength is based on classical lamination theory. Today commercial FE software is used for numerical simulation, and special post-processors have been developed and implemented in software; Abaqus© and ANSYS© are two of the most commonly used.

Finally, such a detailed modeling of fiber behavior is very time-consuming. It is even more problematic when such analysis must be performed repeatedly in an optimization setup.

### JOINING COMPOSITE MATERIALS

Joining of composite structures is a complex task, and, for example, in a T-joint, joining two composite panels at right angle to each other with continuous fiber reinforcement at the corners is quite difficult [8]. Continuous fiber reinforcement facilitates efficient load transfer between the two composite parts and increases the joint strength substantially.

A typical design of this type of joint consists of panels joined by fillet and over laminates, and as there is increasing interest in the use of lightweight fiber-reinforced composite structures for a variety of applications in different industries, the technique of adhesive bonding has to be examined further. It is also important to choose suitable surface treatments and adhesives for the given application. The choice of which adhesive is best is usually dictated by the type of composite to be bonded, the application, the service environment, and cost.

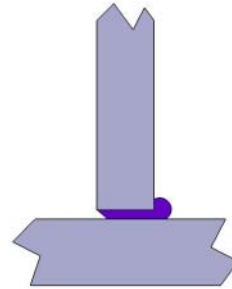

Figure 2. Not symmetric.

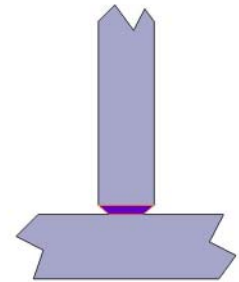

Figure 3. Not enough material.

Verification of joints with carbon fiber composites demands the use of a tensile machine. In our case we tested different types of glued joints to see if there were any differences between them. Often when gluing two composite plates together you cannot see the result as the glued joint may be hidden after the two plates are joined together, for example reinforcement walls that are hidden with a lock after the final assembly. Figures 2 and 3 are examples of glue joints that do not qualify as good glue line.

A standard nozzle for glue injection and another enhanced and specially developed nozzle were used in the first test. Figure 4 is the joint that is going to be glued together. Figure 4 shows the result of using the standard nozzle with perfectly executed glue, and Figure 4 the result of using the enhanced nozzle. One important feature of the enhanced nozzle is that the glue is applied on both sides of the edge to be glued. First, the total area that is treated with glue is larger as we are now able to apply glue on both sides of the vertical plate; see Figure 4. Secondly, the glue line has the same amount of glue regardless of where on the glue line you measure.

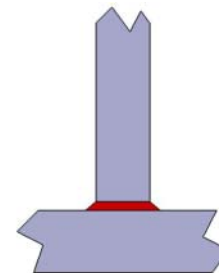

Figure 4. Gluing by using standard nozzle

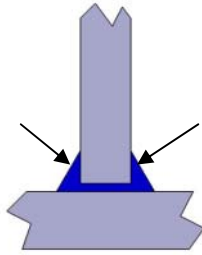

Figure 5. Gluing by using enhanced nozzle.

### Tensile test

As most of the glue lines are hidden after the final assembly, it is difficult to verify the glued composite plates after the assembly. Tensile tests were performed with the glue lines described in Figures 4 and 5. Results showed that an increased force could be used with the enhanced nozzle. In Tables 1 and 2 a comparison between the two nozzles is made. Five different specimens were used for each nozzle.

Table 1. Standard nozzle.

Type	Force	Mpa	Calculated cross section area mm <sup>2</sup>
Std.1	2725	3,3	908
Std.2	2718	3,1	876
Std.3	2013	2,6	774
Std.4	2992	3,5	854
Std.5	2442	2,9	842
<b>Average</b>	<b>2628</b>	<b>3,1</b>	<b>851</b>

Table 2. Enhanced nozzle.

Type	Force	Mpa	Calculated cross section area mm <sup>2</sup>
Enh.1	3068	6,3	487
Enh.2	3333	7,1	469
Enh.3	3478	6,3	552
Enh.4	3452	6,6	523
Enh.5	2240	4,6	487
<b>Average</b>	<b>3284</b>	<b>6,6</b>	<b>504</b>

The tensile tests show that using the enhanced nozzle yields a result that is about 2 times higher as compared with the standard nozzle. The smaller value of the cross-section area results from using the enhanced nozzle, yielding an optimized glue line where glue is applied as it should be. Even though we have a perfect glue line, we still have problems with the delamination; see Figure 6. The overall advantage of using the new and advanced nozzle is that we can be sure that the glue is applied as it is meant to and not as it was with the standard nozzle, Figures 2, 3.

From the tests, it was clear that it is the top surface of the composite plate that delaminates.

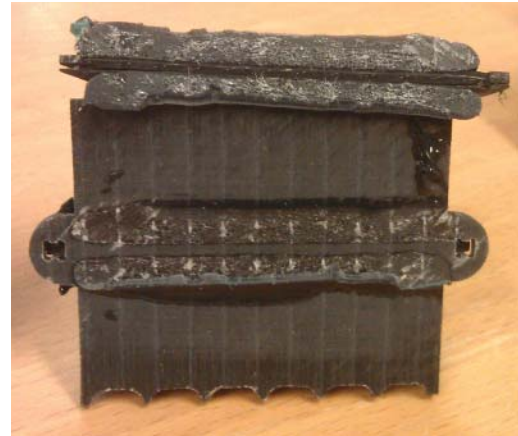

Figure 6. Delimitation of the composite plate.

All tensile tests were performed in the same manner; see Figure 7.



Figure 7. Specimens attached to the tensile machine.

### INDUSTRIAL CASE

During assembly, it is necessary to adjust the locking of the truck driver's storage lids, placed on the cab side of the truck. This is done with help of a gripper that ensures that the locking mechanism is correctly aligned, see Figure 8. As mentioned in the introduction the current gripper was too heavy, therefore difficult to handle for the worker. A second problem was that it often required re-calibration. New and higher tolerances were also desired and this called for new and lighter materials and a new way of designing them. Otherwise, standard components should be the same as for the old gripper and the force (pressure) when using the gripper was set to 350N.

To make a fair assessment between conventional technology and composite technology, we must take into account the experience acquired during the initial development work that utilized conventional technology, experience that then laid the foundation for the new composite design.

We have chosen to normalize the results of composite construction with the exception of weight and maintenance

costs, where we present absolute numbers. A limitation of the study is that the tool has so far only been used for 5 weeks.

One demand expressed at startup of the project was to avoid the many calibrations that the conventional geogripper needs. One of the reasons for this is that when the geogripper is moved from one installation to the next, the user puts it on a moving track. It often happens that the user forgets the gripper, and in that case it continues towards the runway end, which means that the geogripper falls to the ground. If that happens, it requires a new calibration in the workshop. This problem does not exist with the new generation of geogripper, as carbon fiber composite does not have residual deformation. The material returns completely to its original position. If the material is overloaded, it will crack and then the gripper has to be discarded.

### Ergonomics

In a workshop, there are many different handheld grippers, and as the users employ these kinds of grippers several times a day there was a desire to reduce the weight without any loss in performances or tolerances. When employing these handheld grippers, the user's body can be in many different positions.

Several authors have published results from many different tests regarding how to lift equipment ergonomically. People who regularly lift heavy boxes of supplies and equipment require larger muscle forces to be able to perform such lift. Especially the soft tissues of the spine and shoulder joint are vulnerable [9]. Even though lifting devices included in this paper are not particularly heavy, the people that use them on a daily basis will be affected. Reducing weight of grippers, within a reasonable cost, is positive for the users. Users of this specific gripper expressed their wish for lighter grippers, and it was suggested that new grippers made of a material that requires less time for adjustment would make their work smoother as they do not have to replace grippers so often. This results in a more relaxed pace on the assembly line.

### DEVELOPMENT OF GRIPPER

During the project start, the existing geogripper worked but, from the ergonomic point of view, it was too heavy. The criteria that emerged were that the weight was the most important requirement. We would also ensure that the cost could be on a reasonable level. Another criterion was that the equipment mounted on geogrippers would be unchanged, see Figure 8, as they control the reference points against a global coordinate system.

There was also a demand that all equipment that has to be mounted on the new gripper should be standard components and the same as used for the old gripper. Referring to the section about joints, it was decided to use a different approach when putting the different composite plates together. It is clear that glued joints are a weakness when working with composites

and therefore another assembly technique, compared with metal material, must be used. Traditional grippers, made by aluminum or steel, are normally welded or bolted together. To avoid stresses in the glued joint and make sure that the glued joint is not a weakness in the design, the principle of mechanical locking was used on all parts using carbon fiber composite as material. Mechanical locking means that the composite plates are locked to each other along a predetermined direction. Figure 9 shows how the composite plates are locked together. This technique also has an advantage when the composite plates are fixed. The gripper becomes more stable during assembly and the glue can harden easier; a special fixture for the assembly operation is not necessary.

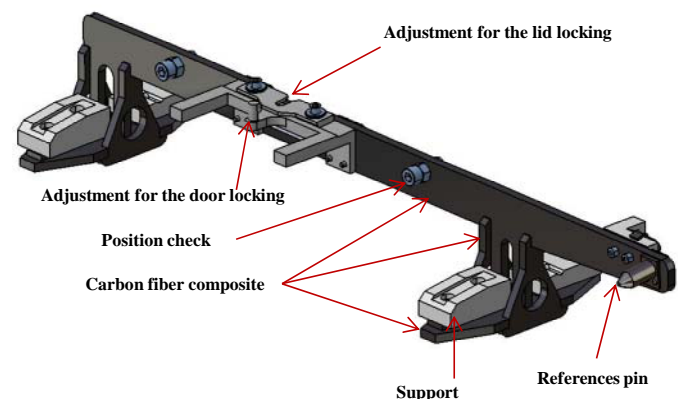

Figure 8. Equipment mounted on the gripper.

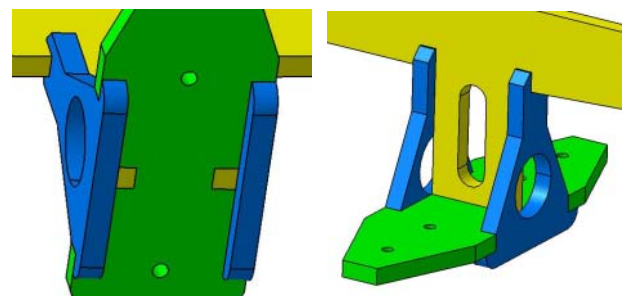

Figure 9. Mechanical locking of composite plates.

When the gripper was modeled in the CAD software, it was easy to see that the new weight was reduced from 4.2 kg down to 1.8 kg by using carbon fiber composite. See Table 3 for a comparison between materials used for manufacturing grippers. This new type of structure can also be used on other types of grippers [10].

It is now possible to easily use the modular approach, which then facilitates the removal of unique features of the product and replaces them with details that can be used in a variety of geogrippers. Another advantage is that this technique involves the use of prefabricated elements, which will mean that, in addition to the weight, the cost will be reduced.

Table 3. Material comparison.

Material	Density kg/m <sup>3</sup>	Tensile value MPa	E-modulus Gpa
Aluminum	2870	100 – 370	69
Steel	7840	320-590	210
Carbon Fiber Composite* *Linear to failure	1800	1200* * Value from tensile tests	230–377

### DESIGN ANALYSIS OF THE GRIPPER CONCEPT

In next two sections an analysis of the gripper has been done. First, it was necessary to establish an analysis model for the carbon fiber composite. After the tensile test and the validation of the analysis model, the analysis of the gripper could be done.

#### Analysis model for Carbon Fiber Composite.

An analytical model for carbon fiber laminates was developed; the missing information was the fiber and the matrix of individual material properties to determine the elastic modulus of the lamina. To be able to trust that laminate theory is implemented correctly, it was decided that the analysis model would be compared with a number of tensile tests. The laminate tensile test was not on what the current product is made of, but one produced by Carbonia Composites AB. This laminate is a woven carbon fiber reinforced thermosetting resin with fiber directions 0-90 °.

The tensile tests were conducted as uniaxial tensile tests on a 150x13x3 mm rod with strain gauges positioned in the drawing direction and across the center of the rod; see Figure 8. The strain gauges were type 3/120LY11 from HBM with donor factor 2.03 and cross-sensitivity 0.2%. Calibration of the sensors was made before the tensile tests, and a dummy sensor was coupled in to compensate for temperature variations. Tensile samples were clamped into the machine and pulled in the longitudinal direction with a gradually increasing force up to 12 kN; data from the strain gauges were logged continuously. The strain gauge as set across the direction of pull on the rod must also be corrected for cross-sensitivity. The strain gauges are exposed for a significant stretch in their own transverse direction, unlike the other sensors; see Figure 10.

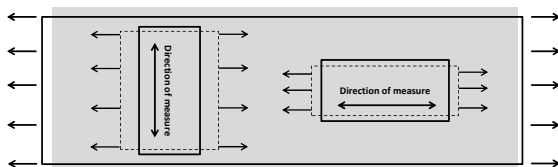

Figure 10. Schematic of the sensors on the rod

The tensile test on the rod exhibited a linear-elastic behavior during the whole load.

### Design analysis of the gripper

In order to do optimizations of fiber direction in the laminate, laminate theory must be applied. The material goes from being orthotropic to being anisotropic, i.e. different properties in all directions. It is possible to apply the laminate theory in a number of ways. ANSYS was used for this analysis of the carbon fiber composite. To be able to do the analysis with ANSYS, a macro was used for importing the analysis model, as ANSYS lacks a composite modeler. A consulting company develops the macro used for the analysis, and they do not want to make this public. A brief description of the macro:

- Model, boundary conditions and load case are loaded.
- Defining elements and how many layers to be used.
- Thickness of layers.
- Material properties for the matrix and carbon fiber.
- Material properties for the layers.
- Solving and post-processing.

By describing fiber direction and the layer properties for each layer, ANSYS is able to analyze the model according to laminate theory. Table 4 lists material properties used for the analysis. Compared with the tensile tests on the rod, computer-based structural analysis provides an equivalent answer, with deviations of 2-3%.

Table 4. Material data for fiber and matrix

Fiber Toray T700		Matrix, Standard epoxy	
$E_{fx}$	230GPa	$E_m$	4,4 GPa
$E_{fr}$	23 GPa	$V_f$	50 %
$V_f$	50 %		

Even though we have a good result, there can be inaccuracies in the test data. Incorrectly installed strain gauges and/or calibrated amplifier can produce deviations. From this analysis with carbon fiber composites and tensile tests, an equivalent analysis material has been developed and used in this case, as we want to be able to perform all analysis inside the CAD software. In order to ensure the composite material mechanical properties compared with steel, an FE analysis where performed. From the users we estimated that the force to be used should be 350N.

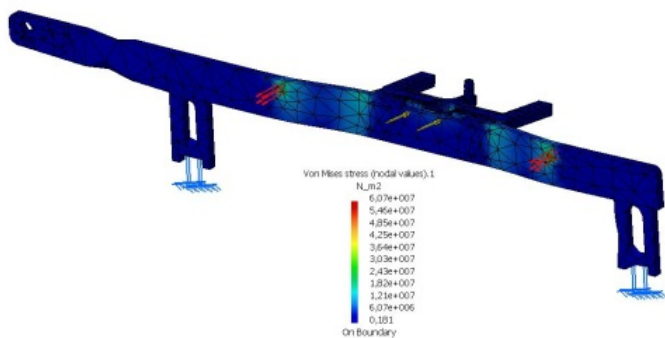

Figure 11. Stresses in the gripper.

The same force was used in the analysis of both materials. As a result, the composite was given a deformation that is 5 times greater. Total deformation of stated force was 0.16 mm; see Figures 11 (Stresses) and 12 (Deformation). We expected that this deformation did not matter because of its small size. This new type of structure also opens up possibilities for other types of geogripper that can use the same technology.

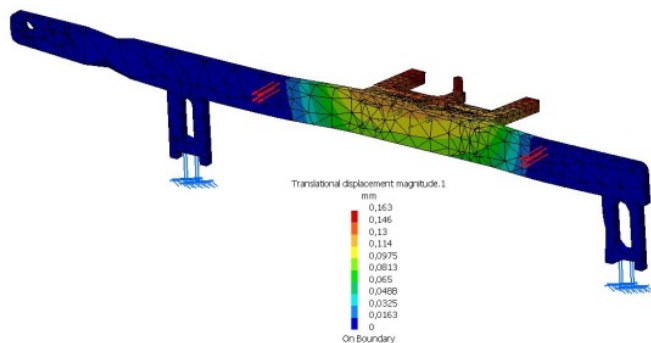

Figure 12. Deformation of the gripper.

It is now possible to use the modular approach, which then causes the removal of unique features of the product and replaces them with details that can be used in a variety of geogrippers.



## CONCLUSION

Using advanced materials is a challenge in an area where steel has been used for many different applications. Carbon composite materials are one such alternative that has excellent material properties. This paper shows that it is possible by changing material to achieve both lighter automotive industry production equipment and enhanced performance at the same time, which in the end will result in enhanced productivity. The lighter equipment also has the advantage of the ergonomic benefits for those who use the gripper, in this case, a gripper that is 60% lighter. Table 5 lists three different grippers and their specific costs. Users in the workshop responded that it is easier to use this new carbon fiber gripper, and they can feel less tension in their body. After 5 weeks of testing, a request was made for the gripper to be stiffer when used, as it felt a little weaker than the old gripper did. We decided to make a new gripper with a thicker carbon fiber plate. The first tests with this reinforced gripper were that it felt stiffer. The new weight of this reinforced gripper was only 0.2 kg heavier than the first one.

By using mechanical locking, the problem of using glued joints with composites has been solved.

The study clearly shows that the composite material represents a favorable alternative to conventional materials for automotive industry production equipment, as the system combines superior properties without significantly increasing the cost of the equipment.

Table 5. Specific cost of different type of grippers.

			
Material	Mild Steel	Mild Steel	Carbon composite
Weight	4.2 kg	3.34 kg	1.8 kg
Design cost	1.0	1.5	1.0
Prototype cost	1.2	5.0	1.0
Manufacturing cost	0.5	0.7	1.0
Maintenance cost, hour/ week	0.0	2.0	0.0
Function	Unacceptable	Acceptable	Preferred solution



## ACKNOWLEDGMENTS

This work was partly supported by the Swedish Governmental Agency for Innovation Systems, VINNOVA, through the Manufacturing Engineering Research Area (MERA) program (project L-FAM II, #2006-00129 [11]).

The author of this paper would like send his gratitude to the students, Shemsedin Ibraimi and Niklas Börjesson, for their work in investigating glued lines as a joint for composite plates and the developing of the enhanced nozzle.

## REFERENCES

- [1] Agarwal, B. D., Broutman, L. J. and Chandrashekhara, K., 2006, *Analysis and Performance of Fiber Composites*, 3<sup>rd</sup> Edition, Wiley, Hoboken, NJ.
- [2] Damberg, H., 2001, *The Composite Handbook: Polymer-Based Fiber Composites (In Swedish. Original title: Komposithandboken : polymerbaserade fiberkompositer)*, New, Rev. Edition, Sveriges verkstadsindustrier (VI), Stockholm.
- [3] Kormaníková, E., Riecky, D. and Žmindák, M., 2011, "Strength of composites with fibres", in Murín J., Kompís V. and Kutíš V. (Eds), *Computational Modelling and Advanced Simulations*, 2011, Springer, Dordrecht, pp. 167-183.
- [4] Lekhnitskii, S. G., 1981, *Theory of Elasticity of an Anisotropic Body [Translated from Russian]*, Mir Publisher, Moscow.
- [5] Werius, P., 2008, *Modelling of Carbon Fiber Structures to a Design System for Production Equipment (In Swedish. Original title: Modellering av kolfiberstrukturer till konstruktionssystem för produktionsutrustning)*, Master Thesis, Division of Machine Design, Department of Design Sciences LTH, Lund University, Lund.
- [6] Zitoune, R., Crouzeix, L., Collombet, F., Tamine, T. and Grunevald, Y. H., 2011, "Behaviour of composite plates with drilled and moulded hole under tensile load", *Composite Structures*, **93**(9), pp. 2384-2391.
- [7] Holloway, C. L., Sarto, M. S. and Johansson, M., 2005, "Analyzing carbon-fiber composite materials with equivalent-Layer models", *IEEE Transactions on Electromagnetic Compatibility*, **47**(4), pp. 833-844.
- [8] Banea, M. D. and da Silva, L. F. M., 2009, "Adhesively bonded joints in composite materials: An overview", *Proceedings of the Institution of Mechanical Engineers.Part L: Journal of Materials Design and Applications*, **223**(1), pp. 1-18.
- [9] Waters, T., Baptiste, A., Short, M., Plante-Mallon, L. and Nelson, A., 2011, "AORN ergonomic tool 6: Lifting and carrying supplies and equipment in the perioperative setting", *AORN journal*, **94**(2), pp. 173-179.
- [10] Petersson, H., Motte, D., Eriksson, M. and Bjärnemo, R., 2012, "A computer-based design system for lightweight grippers in the automotive industry", *International Mechanical Engineering Congress & Exposition - IMECE2012*, Houston, TX.
- [11] Vinnova, 2006, *Manufacturing Engineering Research Area (MERA) Program (project L-FAM II, #2006-00129)*, Vinnova.