



# LUND UNIVERSITY

## Current fire research and design - Particularly in view of mathematical modelling

Pettersson, Ove

1983

[Link to publication](#)

*Citation for published version (APA):*

Pettersson, O. (1983). *Current fire research and design - Particularly in view of mathematical modelling*. (LUTVDG/TVBB--3018--SE; Vol. 3018). Division of Building Fire Safety and Technology, Lund Institute of Technology.

*Total number of authors:*

1

### General rights

Unless other specific re-use rights are stated the following general rights apply:

Copyright and moral rights for the publications made accessible in the public portal are retained by the authors and/or other copyright owners and it is a condition of accessing publications that users recognise and abide by the legal requirements associated with these rights.

- Users may download and print one copy of any publication from the public portal for the purpose of private study or research.
- You may not further distribute the material or use it for any profit-making activity or commercial gain
- You may freely distribute the URL identifying the publication in the public portal

Read more about Creative commons licenses: <https://creativecommons.org/licenses/>

### Take down policy

If you believe that this document breaches copyright please contact us providing details, and we will remove access to the work immediately and investigate your claim.

LUND UNIVERSITY

PO Box 117  
221 00 Lund  
+46 46-222 00 00

LUND INSTITUTE OF TECHNOLOGY · LUND · SWEDEN  
DIVISION OF BUILDING FIRE SAFETY AND TECHNOLOGY  
REPORT LUTVDG/(TVBB - 3018)

OVE PETTERSSON

CURRENT FIRE RESEARCH AND DESIGN –  
PARTICULARLY IN VIEW OF MATHEMATICAL  
MODELLING

LUND 1983

LUND INSTITUTE OF TECHNOLOGY  
DIVISION OF BUILDING FIRE SAFETY AND TECHNOLOGY  
P.O.Box 725  
S-220 07 LUND, Sweden

REPORT LUTVDG/(TVBB-3018)

OVE PETTERSSON

CURRENT FIRE RESEARCH AND DESIGN - PARTICULARLY IN VIEW OF  
MATHEMATICAL MODELLING

LUND 1983 (1984)

Presented at the CIB 9th Congress in Stockholm, 15-19 August,  
1983 and slightly modified in connection with an open lecture  
at Science University of Tokyo, 20 April, 1984

Title\_of\_the\_paper

CURRENT FIRE RESEARCH AND DESIGN - PARTICULARLY IN VIEW OF  
MATHEMATICAL MODELLING

Author

Prof., Dr. Ove Pettersson

Organization/Enterprise

Division of Building Fire Safety and Technology,  
Lund Institute of Technology, Sweden

Key\_words

Fire research/Fire design/Mathematical modelling/Fire growth/  
Flashover/Fully developed fires/Reaction of materials/Fire  
spread between buildings/Structural fire safety

Summary

With the general trends of the international development of codes, specifications and recommendations for a fire engineering design as a background, the rapidly expanding modelling capabilities are demonstrated and exemplified with respect to the fire growth in a compartment, the fully developed compartment fire, the reaction to fire of materials, the fire spread between buildings, and the fire behaviour of building structures. The progress within the field of fire research and design is now characterized by a real breakthrough towards an increasing application of analytical methods with an improved connection to real fire conditions and based on well-defined functional requirements and performance criteria.



CURRENT FIRE RESEARCH AND DESIGN - PARTICULARLY IN VIEW OF  
MATHEMATICAL MODELLING

Ove Pettersson

Division of Building Fire Safety and Technology

Lund Institute of Technology, Sweden

During the last decade, the knowledge of fire characteristics and related effects on materials, building components and structures has increased considerably. In consequence, a rapid development now occurs internationally in the field of codes, specifications and recommendations for a fire engineering design in a broad sense. Some typical trends in this development are:

- \* An improved connection to real fire conditions,
- \* an increasing extent of design, based on functional requirements and performance criteria,
- \* a development of new test methods, which are, as far as possible, material independent and directly related to well-defined properties and phenomena,
- \* an increasing application of analytical design - reliability-based in its most advanced form,
- \* an extended use of integrated assessments, and
- \* an introduction of goal-oriented systems of analysis of the total, active and passive fire protection for a building.

Some of these trends will be illustrated below with particular reference to the reaction to fire of materials, the fire spread between buildings and fire behaviour of building structures. Mathematical modelling as a tool in fire research and design then will be the main theme in the discussion. As a background, the presentation starts by a brief review of the state of the art regarding compartment fires.

## 1. Compartment Fires

A fire starts in a compartment when sufficient energy is supplied to combustible material through, for instance, a burning cigarette or an electrical short-circuit, for the material to ignite or when the material generates this energy by itself (self-ignition). Decisive influences for the process of ignition are (Fig. 1):

- \* The characteristics of the source of energy,
- \* the type and geometrical properties of the material exposed, and
- \* the time of thermal exposure.

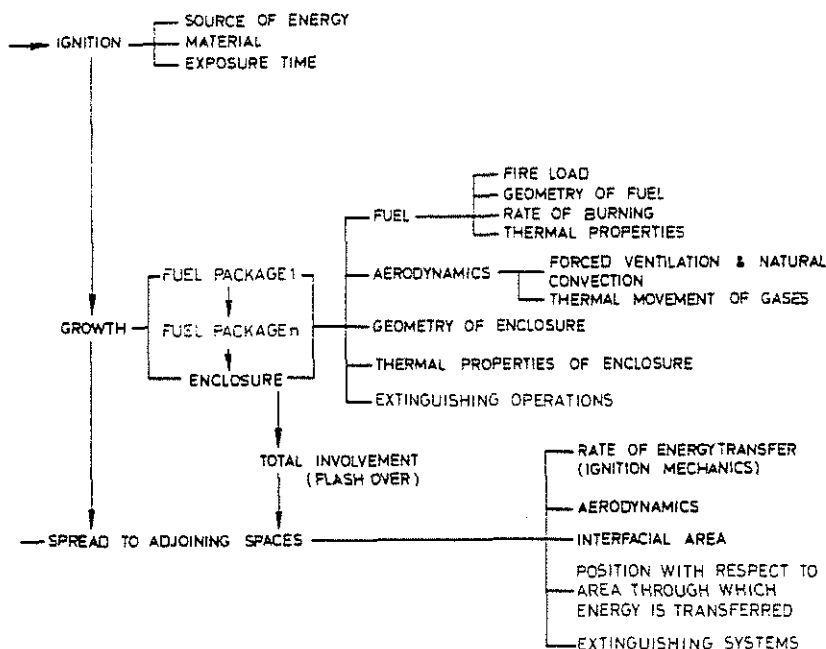

Fig. 1 Factors affecting ignition, growth and spread of fire in a building. A fuel package is a fire load component, e.g. a curtain, a piece of furniture or a group of furniture in an office landscape

After ignition, the fire produces thermal energy. Some of this is used as feedback to maintain the combustion. Some of it is transferred via radiation and convection to other materials in the compartment which are then heated and may ignite and contribute to the spread of fire - Fig. 2. Once an initial fire has occurred in a compartment, its process of growth and spread is determined by (Fig. 1)

- \* the size, volume and arrangement of the fuel or fire load, its distribution in the compartment, and its continuity, porosity and combustion properties,
- \* the aerodynamic conditions of the compartment,
- \* the shape and size of the compartment, and
- \* the thermal properties of the compartment.

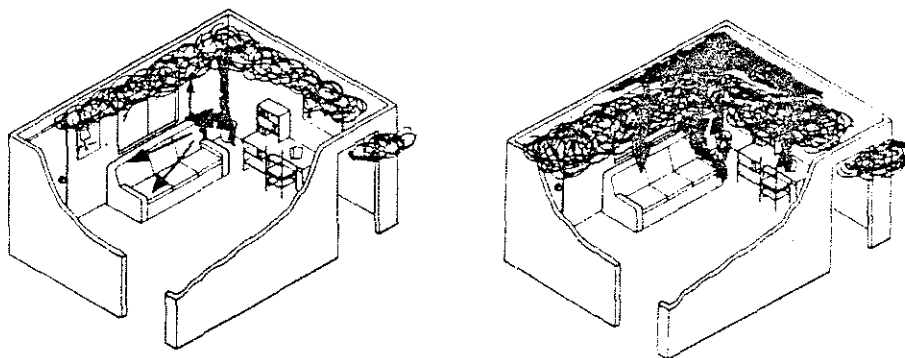

Fig. 2 Fire occurrence and spread in a compartment

If extinguishing systems are installed, the fire growth process is influenced further by

- \* the design and workability of these systems, for instance, a sprinkler system.

The development of the fire generally comprises thermal, aerodynamic and chemical processes, governed by a complex interaction between several mechanisms. As a rule radiation, convection and flame spread are the dominant physical factors - Fig. 3.

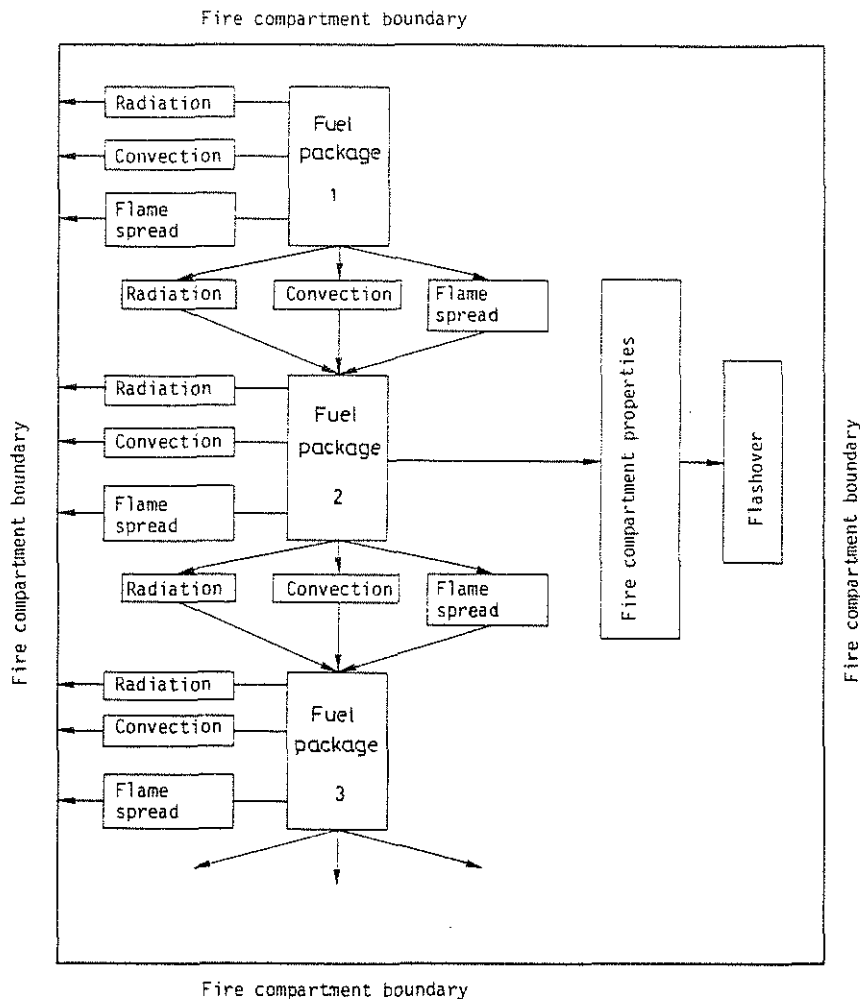

Fig. 3 Fire growth in a compartment through radiation, convection and spread of flame

During the fire growth, a hot gas layer is built up under the ceiling of the fire compartment (Fig. 2). Under certain conditions, this gas layer can cause a rapid spread of fire over the entire ceiling which then can lead to an inclusion of large parts of the total fire load in the fire - flashover occurs.

A summary analysis of the more general concept of flashover and the processes involved has been given by Thomas et al and reference is made to [1-3] in this connection.



To predict flashover, different criteria have been introduced. One refers to flames reaching the ceiling of the compartment. Another defines flashover as the time when flames just begin to emerge from the openings of the compartment, which correlates with a temperature of 500-600°C in the upper gas layer [4]. A third criterion relates to a critical resulting radiation at the floor level of the room or compartment of  $2 \text{ W cm}^{-2}$  [5]. The criteria are all different and correspond to different physical circumstances.

Based on the resulting correlation observed in over 100 experiments and on a supplementary study of the approximate energy and mass balances, the following equation

$$\dot{h}_{c,perm} = 610 (\alpha_k A_t A \sqrt{h})^{\frac{1}{2}} \quad (\text{kW}) \quad (1)$$

is derived in [6] to provide guidance in determining the maximum heat release rate  $\dot{h}_c$  permissible in order to prevent flashover for a given room or fire compartment with non combustible wall linings. In the equation,  $\alpha_k$  = an effective heat transfer coefficient of the structures surrounding the room or compartment ( $\text{kW m}^{-2} \text{K}^{-1}$ ),  $A_t$  = total interior area of the surfaces, surrounding the room or compartment, opening area included ( $\text{m}^2$ ),  $A$  = total opening area ( $\text{m}^2$ ), and  $h$  = height of openings (m).

The equation clearly shows the influence of the ventilation of the room or compartment ( $A\sqrt{h}$ ) and the size and thermal properties of the enclosure ( $\alpha_k A_t$ ) on the likelihood of flashover. The formula correlates with a temperature of 500°C of the upper gas layer in the compartment. The experiments behind the formula apply to enclosures of moderate size with most of the fire load located near the centre of the room, i.e. there were no wall or corner fires.

Flashover marks the transition from the growing fire (pre-flashover) to the fully developed fire (postflashover).

The preflashover fire is of decisive significance with regard to the level of safety required for the escape or rescue of people. The response of detectors, alarm systems and sprinklers belongs to this period of the fire.

The postflashover fire is significant with respect to the fire behaviour of the load bearing structures, the spread of a fire from one fire compartment to another via partitions and ventilation systems (Fig. 1), the external spread of fire from one storey to another in a multi-storey building and the spread of fire from one building to another. With respect to life safety, the postflashover fire is important by the effect of the combustion products on people in remote parts of the building. The entire fire process - the preflashover as well as the postflashover fire - is of primary concern for the fire brigade people. Finally, a qualified knowledge of the postflashover fire is a prerequisite for assessing the safety of the clearance squad and for an analysis of the residual state and the possibilities of reusing a building after fire.

### 1.1 The Preflashover Fire

The fundamental characteristics for a description of the preflashover fire are:

- (1) The ignition properties of exposed materials as a function of the heat supplied, the exposure time, the presence or not of flames, the geometrical location and thermal data,

and the time variations of the

- (2) rate of heat release, RHR,
- (3) rate of flame spread,
- (4) gas temperature,
- (5) smoke and its optical properties, and

- (6) composition of the combustion products, particularly toxic and corrosive gases.

Friedman identifies seven components of the preflashover compartment fire which are relevant in the fire growth to flash-over [7]: The burning object, the flame, the hot gas layer, the cold gas layer, the vents, the target objects not yet ignited and the inert surfaces, e.g. the ceiling. Fig. 4 shows 20 interaction vectors between these components. Several of these interactions have multiple elements - for instance, the heat transfer from the hot layer to the ceiling involves convection, radiation, and conduction within the ceiling material.

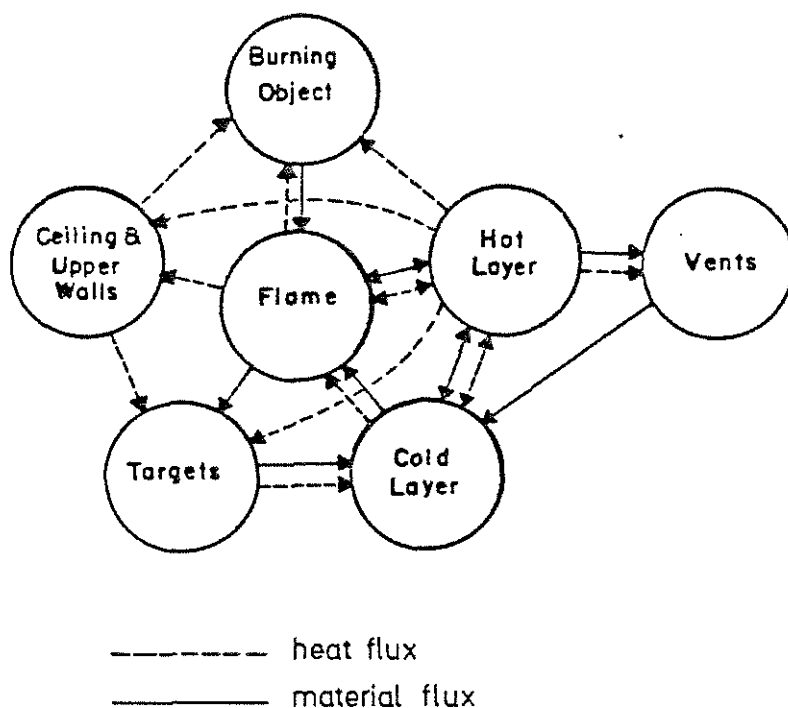

Fig. 4 Components and their interactions in a preflashover room fire model [7]

In the figure, special attention should be paid to the feedback loops, since positive feedback is a decisive part of the fire growth. As an example, it can be noted that heat is

transferred from the flame to the hot layer to the ceiling. After a time lag, the ceiling gets hot enough to radiate to the burning object, increasing its rate of pyrolysis and making the flame larger.

The components have direct relevance for that group of preflash-over compartment fire models, comprising the zone models - alternatively called modular or control volume models. The models have recently been reviewed in [2, 7, 8], cf. also [9].

In a zone model, a number of zones or control volumes are defined in the compartment with different processes dominating in each zone. The self-contained zones are then dealt with as thermodynamic control volumes, tied together by energy and mass transfer conservation equations. Generally, each zone as well as the interchanges between the zones are described by relatively simple equations.

Over the last ten years, several zone models have been constructed with varying degree of detailing and range of application. Among the first models to appear was the one constructed by Quintiere in 1976 [10] - Fig. 5. The model embraces three control volumes (CV). The fuel CV<sub>I</sub> is considered

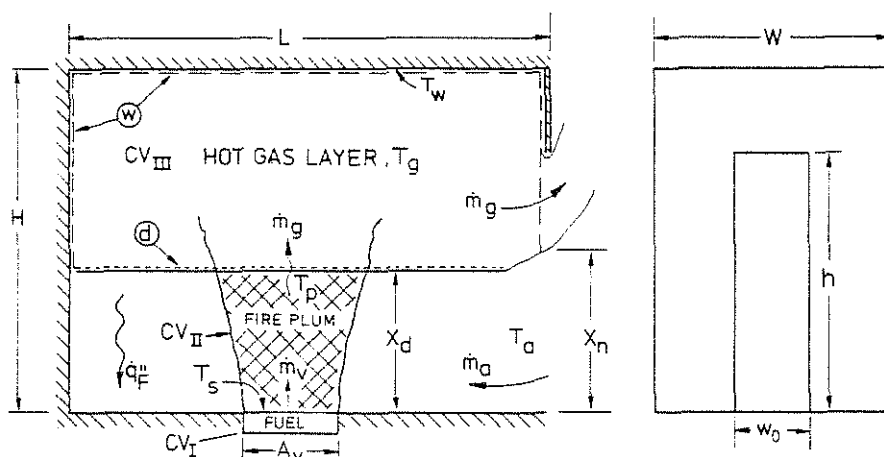
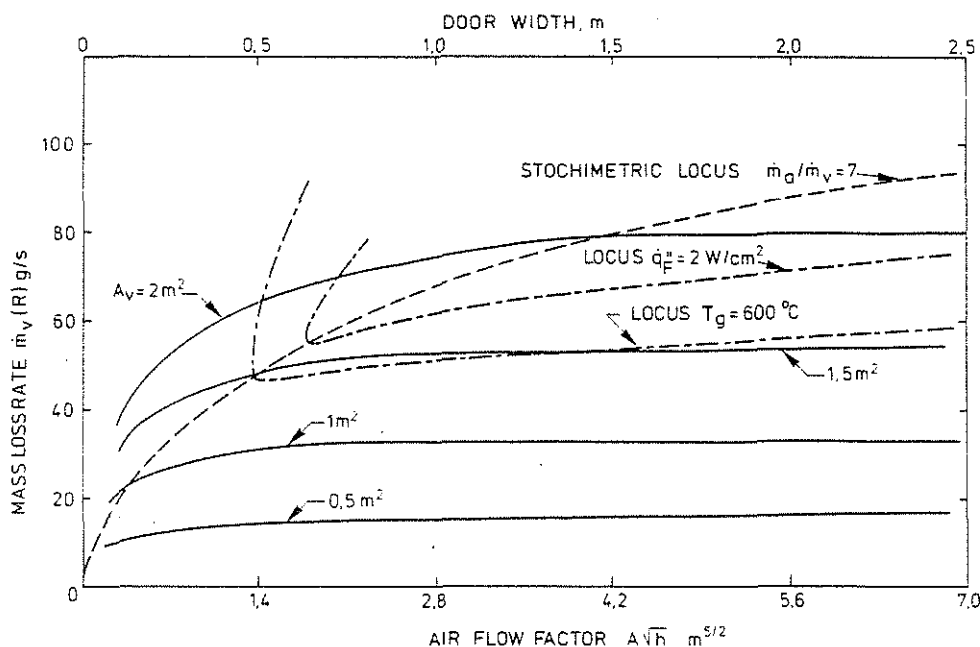

Fig. 5 Zone model, constructed by Quintiere in 1976, for the preflashover compartment fire [10]

to be a vaporizing solid. A flame and a plume  $CV_{II}$  rises above the fuel and is assumed to be the region where all combustion occurs. The hot combustion products and entrained air then collect in the upper part of the compartment - the hot gas layer  $CV_{III}$ . The interface between  $CV_{III}$  and the lower region of the enclosure defines a thermal discontinuity plan  $X_d$ . The original model is quasi-stationary. For given fire compartment characteristics, an iterative calculation procedure gives the equilibrium values of fuel surface area, mass burning rate and temperature of the hot gas layer  $CV_{III}$ .

The ability of the model is illustrated in Fig. 6 [10], which shows the calculated relationship for a defined compartment between the mass burning rate  $\dot{m}_v(R)$  and the air flow factor  $A\sqrt{h}$  for varying fuel areas  $A_v$ .  $A$  is the opening area and  $h$  the opening height. The heat of combustion of the



**Fig. 6** Relationship, calculated by the zone model according to Fig. 5, between the rate of burning  $\dot{m}_v$  and the air flow factor  $A\sqrt{h}$  for varying fuel areas  $A_v$ . Curves are also given, corresponding to the temperature  $T_g = 600^\circ\text{C}$  of the hot gas layer and the radiation  $\dot{q}_F'' = 2 \text{ W cm}^{-2}$  towards the floor [10]

fuel is assumed to  $20 \text{ MJ kg}^{-1}$ . Calculated curves are further given, corresponding to the temperature  $T_g = 600^\circ\text{C}$  of the hot gas layer and the radiation towards the floor  $q_F'' = 2 \text{ W cm}^{-2}$ . These values represent applied criteria for flashover and consequently, the respective areas, enclosed by these two curves, can be seen as areas for occurrence of flashover. The results are roughly in agreement with experiments.

The original Quintiere model has served as a basis for further development work. A generalization of the model to a transient version was presented by Hägglund [11]. The model has later been modified by Quintiere et al - [12, 13], cf. also the discussion in [2] - to include the effect of that part of the hot gas  $\dot{m}_e$  being brought down into the incoming cold air  $\dot{m}_a$  - Fig. 7. The heated mixed stream  $\dot{m}_p = \dot{m}_a + \dot{m}_e$  then is entrained into the fire plume up to the thermal discontinuity plan  $X_d$ .

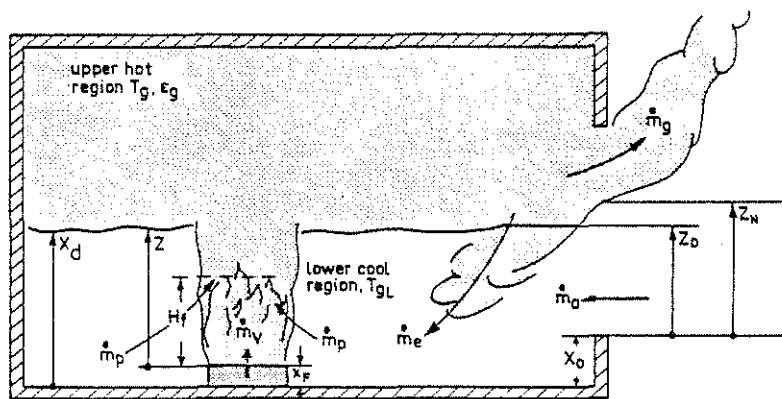

Fig. 7 Zone model according to Fig. 5, modified to include the effect of that part of the hot gas  $\dot{m}_e$  being brought down into the incoming cold air  $\dot{m}_a$  [2, 12, 13]

In a recent paper by Cooper [14], the significance of a wall effect is studied, consisting of a near-wall downward injection of hot upper layer gases  $\dot{m}_w$  into the relatively cool uncontaminated lower gas layer - Fig. 8. The wall flow is



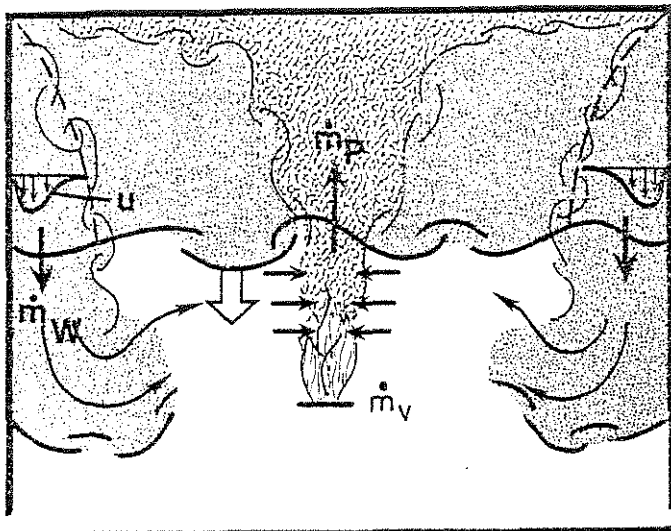

Fig. 8 Influence of a downward injection of hot upper layer gases  $\dot{m}_w$  into the relatively cool uncontaminated lower gas layer in a preflashover room fire [14]

described as buoyancy driven, developing because of the temperature difference between the upper wall surfaces and the hot upper gas layer. In [15], Sundström and Wickström discuss an inverse wall flow effect, characterized by an upward current which is caused by the warming of the lower wall surfaces by radiation from above and is added to the current of the main fire plume.

The described models are by their very nature built for the specific purpose to analyse the preflashover fire, particularly the upper layer depth and gas temperature, for a one-room configuration. However, as pointed out in [7], principally no new physical phenomena appear to be involved in developing a model which is not limited to a single compartment, but predicts the spread of fire from one compartment to a second and to a third. Such a model extension, nevertheless, embraces a series of problems to be solved due to the complex flow pattern in the openings and the difficulties to calculate the air entrainment in the fire plume from one storey to another, among other things.

During the last few years, a number of zone models of more global nature have been developed. In the Tanaka model [16], the equations have explicitly been written to describe the flow in a multi-room situation, even flow from one floor to another. The model includes a comprehensive sub-model for the pyrolysis of wood fuel and smoke density calculations, based on small scale optical smoke density measurements. The model has recently been further improved in several respects [17]. A model on excess fuel burning in arbitrary room has been introduced; a model for prediction of gas concentrations has been added; a subroutine has been included to predict the upper layer emissivity; the code has been revised so that it can deal with tall buildings with less computer memory size, among other things. The ability of the model is illustrated by Fig. 9, showing a sample calculation for a five-storey building. The numbers under the ceiling are giving the temperature rise of the upper gas layer, the numbers at the openings and doorways the flow rate of hot gas or air, and the arrows the flow direction.

The most detailed zone model is the Harvard University Computer Fire Code, developed by Emmons and Mitler [18]. In the version V, the simulation represents fire in a single room with vents opening directly to an infinite plenum and allows up to five objects per room with the possibility of one object igniting another. The simulation provides algorithms for three types of fire, all assuming a smooth, horizontal fuel surface, viz. a gas burner, a fire of fixed area (a pool fire), and a growing fire whose area is a function of time. The input routines allow for entering a large number of room and fuel data. The output from the calculations comprises up to sixty quantities. Fig. 10 [19] exemplifies the ability of the model, comparing measured and calculated heat flux in a specified point, referred to a mattress test carried out at NBS in a room 3.4 m wide, 3.5 m deep and 2.44 m high, ventilated by a single door opening and having walls and ceiling of cement-asbestos board. The model is continuously being improved.

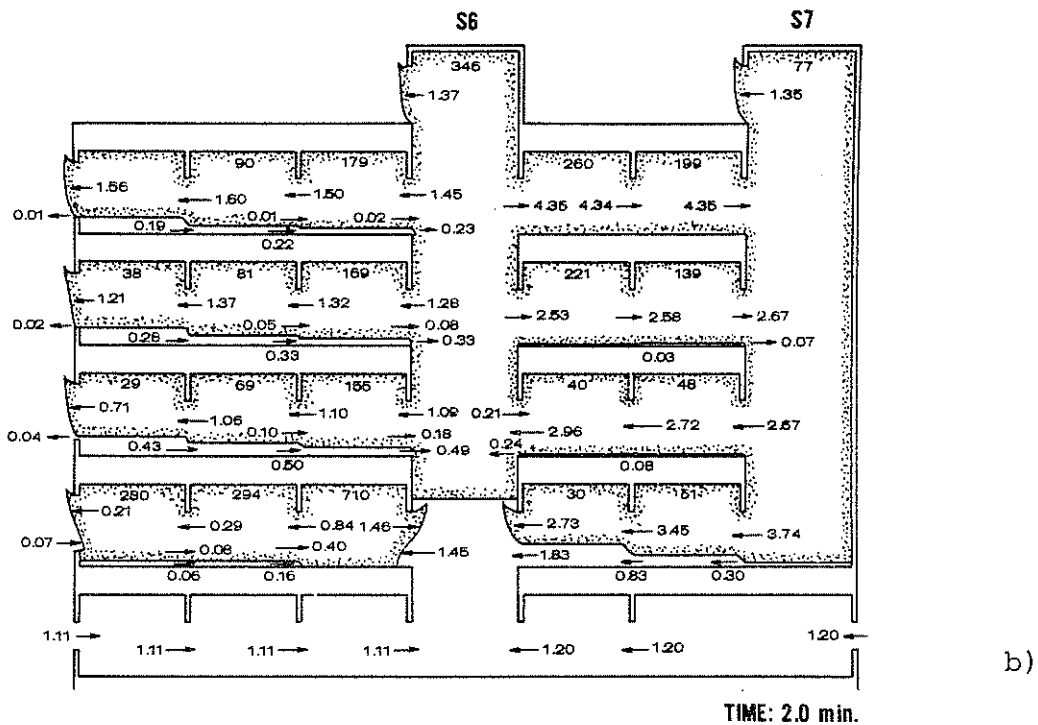
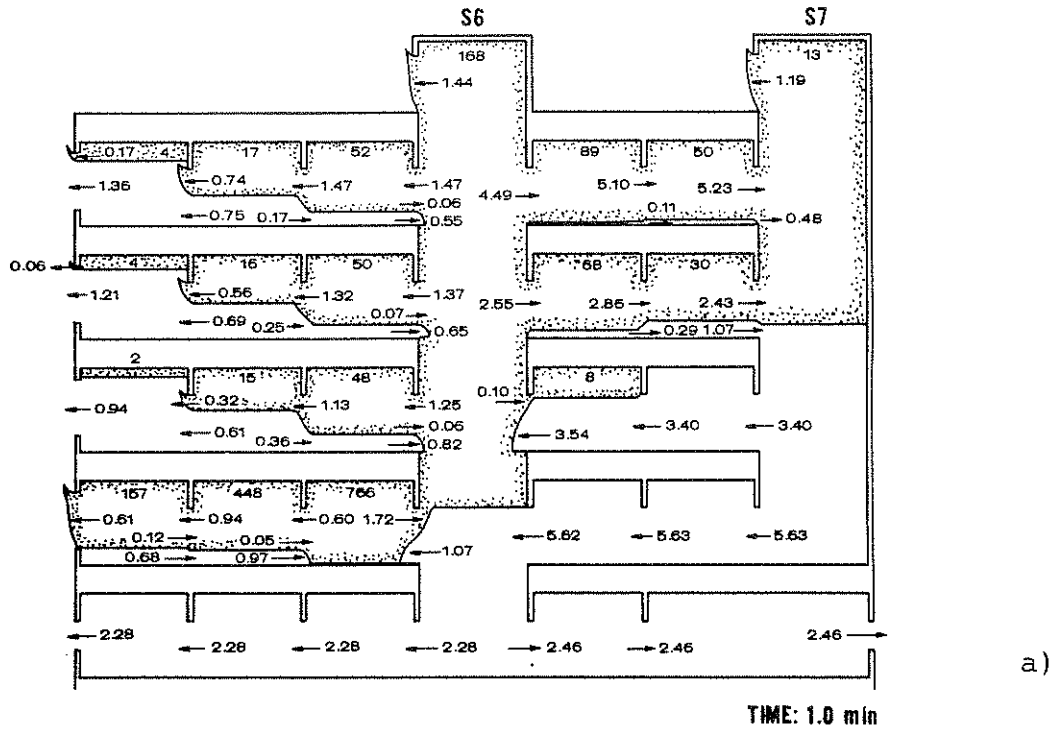

Fig. 9 Multiroom fire spread in a five-storey building after 1 minute (a) and 2 minutes (b) at a fuel rich fire, computed by the Tanaka model [17]. Numbers under ceiling are giving the temperature rise in K, numbers with arrows at openings the flow rate in  $\text{kg}\cdot\text{s}^{-1}$

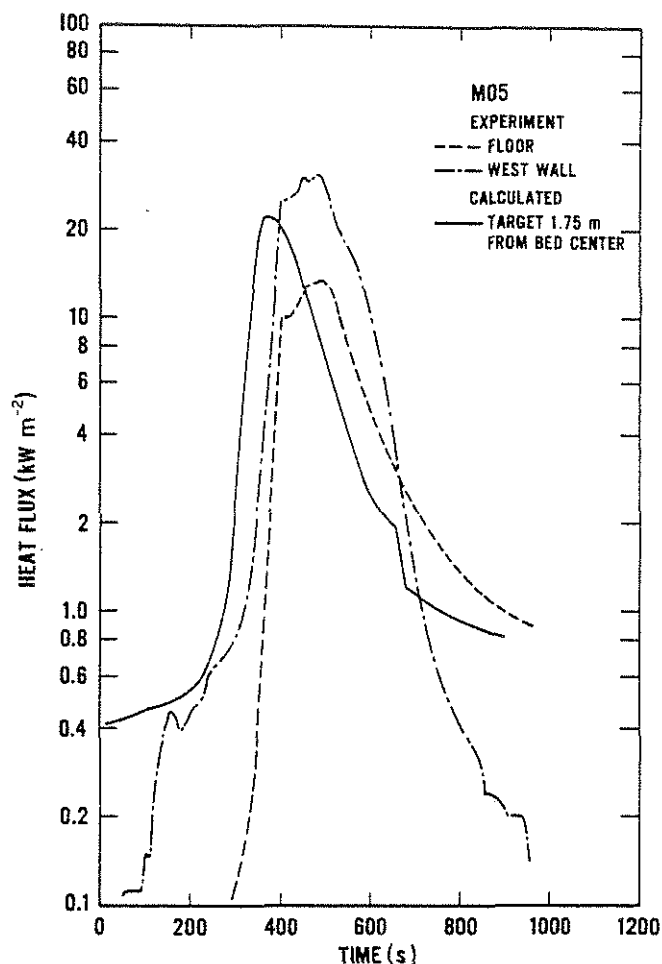

Fig. 10 Comparison of measured and calculated heat flux in a specified point of a room for a mattress fire test [19]

The models reviewed up to now assume ceiling and wall linings of incombustible material. The first attempt to develop a framework for predicting wall flame spread in a room was presented by Quintiere in 1980 [20]. The problem dealt with is wall fire spread in a room following ignition in a corner - Fig. 11. The basis for the analysis is the zone modeling technique, described above. A key element in the approach is a simplified theoretical model of surface spread of flame test apparatus, such as the one being developed by ISO. The goal of the model is to assess the risk of rapid fire growth in a room (flashover) relative to wall property data found through fundamental principles and empirical fire test methods.

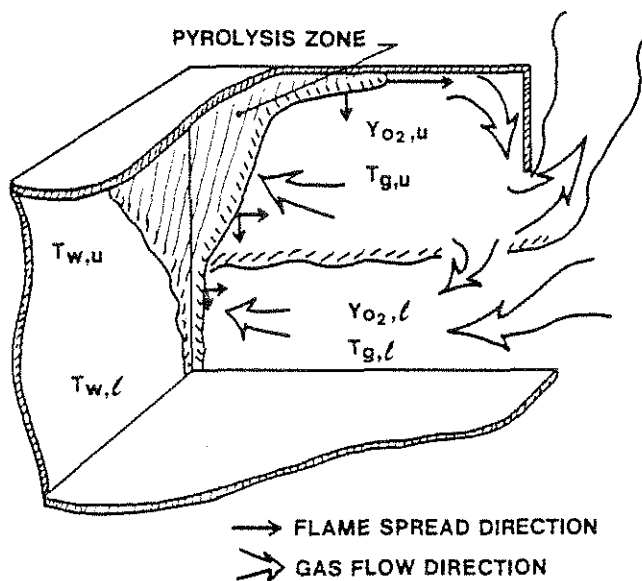

Fig. 11 Wall fire spread in a room following ignition in a corner [20]

The zone models are trying to predict the input and output of the particular zones without giving the details within the zones. The approach provides relative computational simplicity. In a field model of a compartment fire, the space is divided into small volume elements and differential forms of the conservation equations of mass and energy transfer are applied to each element and solved numerically along with the boundary conditions. Accordingly, the field models can potentially provide the most accurate and detailed results. Fig. 12 exemplifies this showing a perspective view of calculated temperature contours, corresponding to 320 and 835 K, respectively, for a fire source in a compartment [21]. A successful application of field models to problems with multiple parameters requires extreme computer capacity. At present, there are limitations of the applicability due to insufficient quality of some of the input data required. The main difficulties then are in the description of turbulence and of radiation.

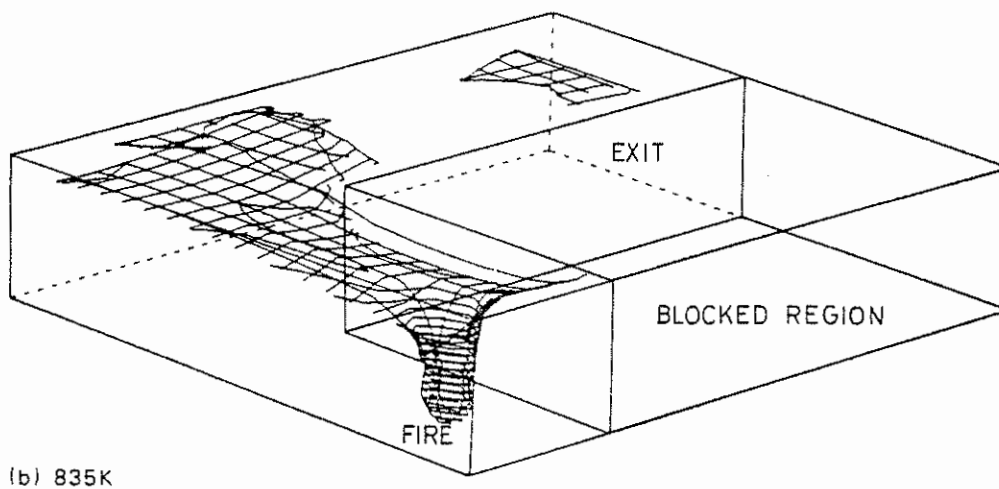
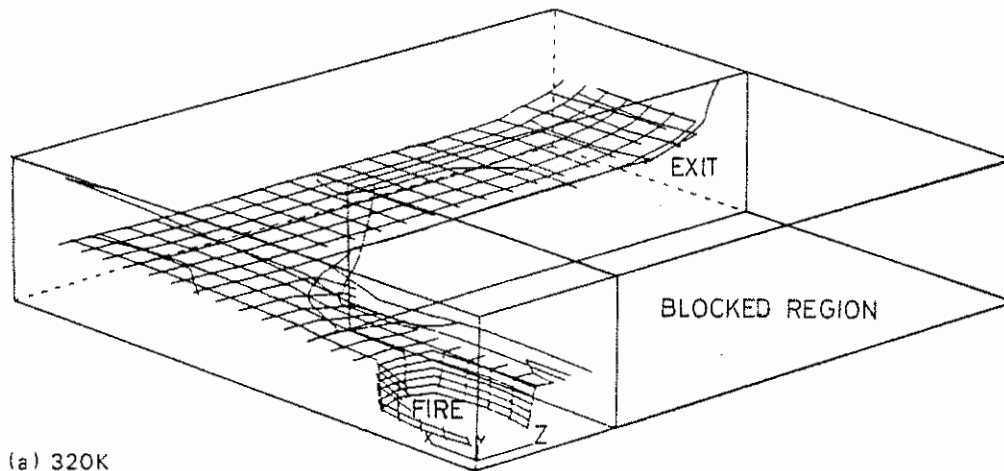

Fig. 12 Perspective view of calculated temperature contours for a fire source in a compartment [21]

The hazard of fires in non-ventilated or closed compartments are well documented by fire statistics. More than 25% of the deaths due to fire in the United States have been attributed to residential fires involving mattresses or upholstered furniture, initiated by smoking materials [22]. The characteristic fire scenario starts with a smoldering fire propagation which may go through a transition to flaming fire spread. This fire scenario is many times as common as any other.

In recent years, work has been initiated on zone modelling of environmental conditions, which develop at a flaming fire in a



compartment, assumed to be closed - except for leaks near the floor or the ceiling - Fig. 13. Contributions by Zukoski [23], Cooper [24] and Hägglund [25], [26] may be referred to as examples. A major goal of the modelling is to provide a tool for estimating the time when the heat and smoke conditions are getting untenable for human life.

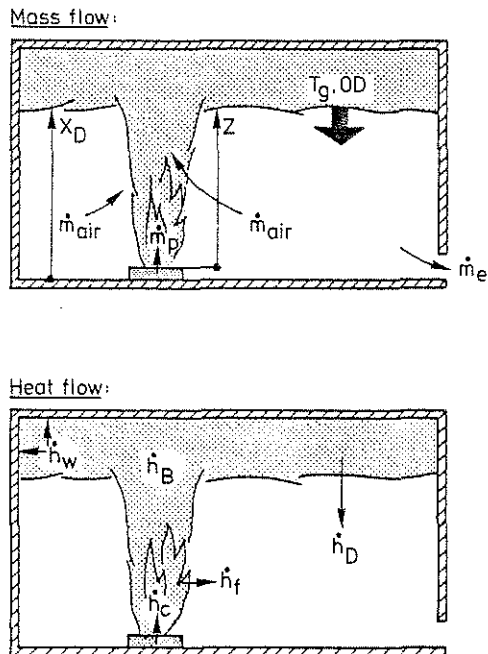

Fig. 13 Mass and heat flow at a flaming fire in a compartment, assumed to be closed - except for leaks near the floor [26]

The modelling predicts the growth of the ceiling layer and the heat and smoke conditions as a function of the fire size, room geometry and leak positions. The interface between the hot ceiling layer and the lower layer of fresh air moves down at a velocity determined by the rate of air entrained into the fire plume  $\dot{m}_{air}$  and by the rate of mass flow through the leaks  $\dot{m}_e$ .  $\dot{m}_p$  denotes the rate of fuel pyrolysis. By means of a mass balance for the lower region it is possible to calculate this drop velocity.

The burning item releases heat at a rate  $\dot{h}_c$ . The heat is lost by radiation and convection to the enclosing structures of the upper gas layer  $\dot{h}_w$ . The upper layer also loses heat by radiation to lower cool region of the compartment  $\dot{h}_D$ . Other loss terms are the radiant heat from the fire plume  $\dot{h}_f$  and the heat to rise the temperature of the upper layer  $\dot{h}_B$ .

Results of the models have shown a reasonable agreement between measured and calculated data.

A computer model of this type has recently been used by Hägglund [26] for a parameter study of the hazardous conditions at a growing fire within non-ventilated compartments of various size (NON-VENT) - Fig. 14. The study also comprises a comparison with the corresponding conditions - as concerns the time to flashover - for compartments, ventilated by vents in the roof to exhaust the hot gases and smoke produced by the fire (VENT).

In the study, the floor area ranges from 500 to 2000 m<sup>2</sup> and the ceiling height from 4 to 10 meters.

The diagram in Fig. 14 a applies to a fire defined by an exponential fire growth rate with a doubling time of 3 minutes. The doubling time then is the time for the fire to double its area. The diagram presents calculated times when critical events - smoke-logging and flashover - occur in the compartment. Smoke-logging is defined by the time when the smoke layer has dropped to the level of 1.5 meter above the floor. The compartment is then assumed to be untenable for safe evacuation and the fighting of the fire becomes hazardous and difficult. The diagram is also giving the calculated times when specified sprinklers and heat and smoke detectors operate.

The diagram in Fig. 14 b gives the corresponding results for a fire with a smaller value of the doubling time,  $d = 2$  minutes. As expected, the times of critical events will be shorter with a decreasing doubling time of the fire growth.

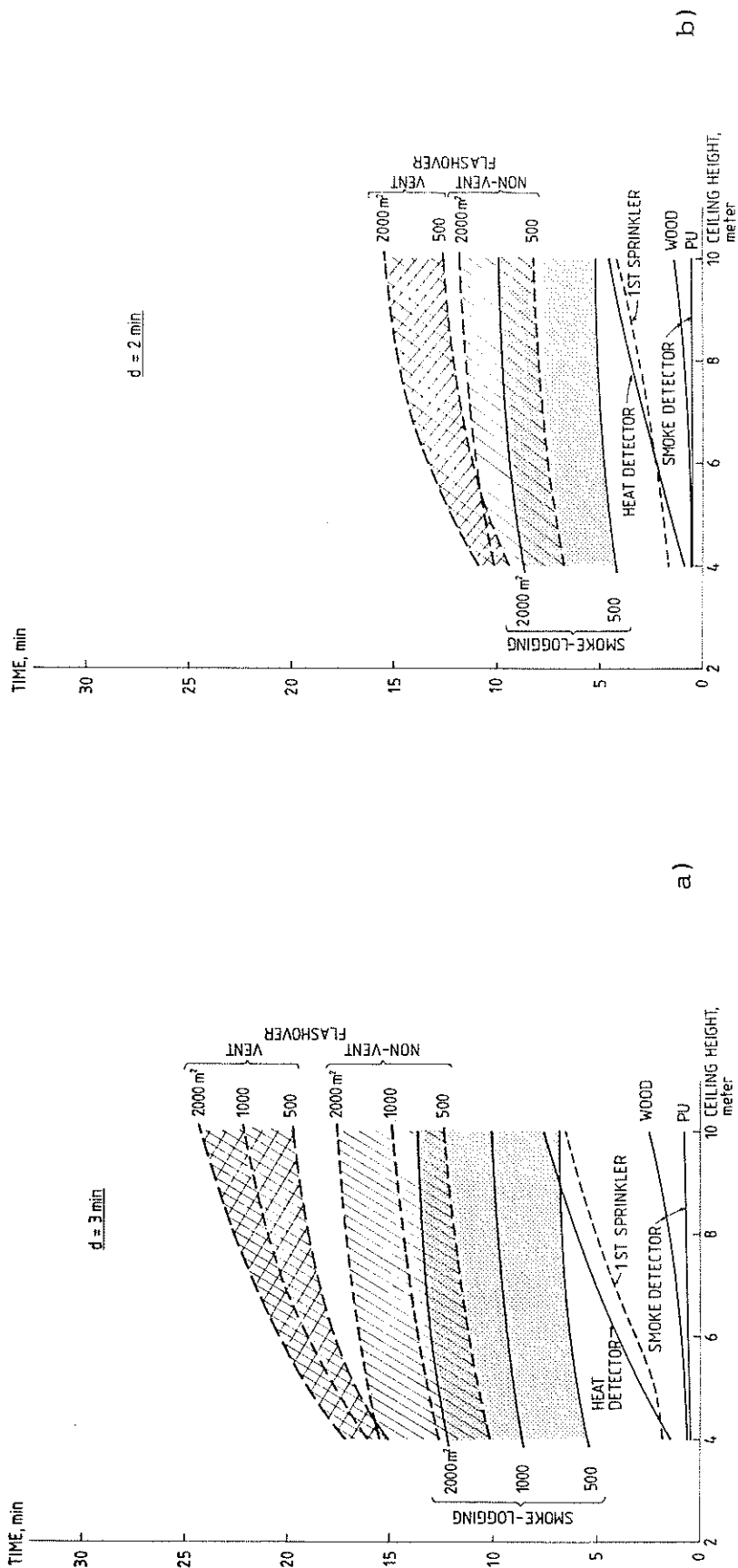

**Fig. 14** Time for the detection and critical events as a function of compartment floor area and ceiling height. Fire with an exponential fire growth rate with a doubling time of 3 minutes (Fig. a) and 2 minutes (Fig. b), respectively [26]

Passing over to non-ventilated fires of the smoldering type, there are only a few experimental studies reported to document the general behaviour of smoldering propagation and its transition to flaming. The first theoretical analysis of the scenario was recently presented by Quintiere et al [27]. The study includes a review of smoldering fire experiments, conducted in closed rooms and buildings, and a theoretical model which requires inputs of the rates of carbon monoxide production and energy release and which can be used for extrapolating test data to compartments of various size. An example of such an extrapolation is referred in Fig. 15 [27], showing the calculated time variation of the CO concentration caused by a chair smoldering in rooms with the height 2.4 m and various

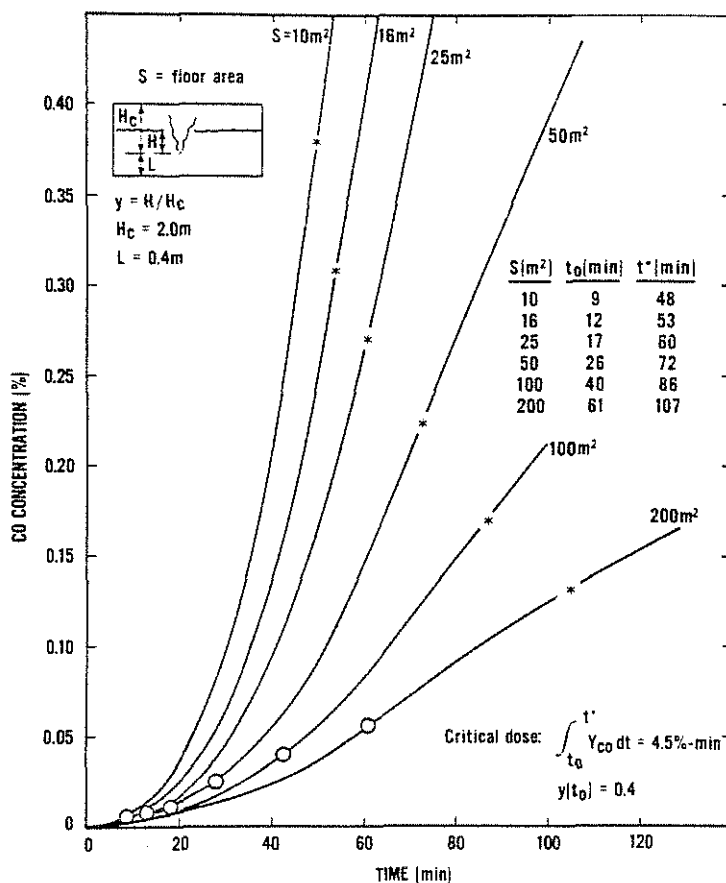

Fig. 15 Calculated CO concentration versus time caused by a chair smoldering in a room with the height 2.4 m and varying floor area  $S$ .  $t_0$  is the time for the layer interface to descend to the reference point, located at the mid-height of the room, and  $t^*$  the time when a critical dose would be exceeded [27]

floor areas  $S$ . The values relate to a hypothetical sensor at the mid-height of the room. The time  $t_0$  for the layer interface to descend to this point and the time  $t^*$ , when a critical dose would be exceeded, are listed on the figure and also marked on the curves.

## 1.2 The Postflashover Fire

The fully developed or postflashover compartment fire is the one most widely studied and during the past 20 years several analytical simulation models have been presented, primarily developed for the application to problems of structural safety. In a review paper [28], recently published, Harmathy and Mehaffey have classified 14 mathematical models of the postflashover compartment fire on the basis of 14 principal modelling aspects. The models included have been judged either to represent important steps in the evolution of knowledge or to offer unique concepts.

The fundamental characteristics for a full description of the postflashover fire are the time variations of the

- (1) rate of heat release, RHR,
- (2) gas temperature,
- (3) geometrical and thermal data for external flames,
- (4) smoke and its optical properties, and
- (5) composition of the combustion products, particularly toxic and corrosive gases.

The simulation models, developed for structural safety purposes, then concentrate on the characteristics (1)-(3). Most models are partly theoretical and partly empirical with the empirical part focusing on data on the rate at which the fuel is consumed. The models generally appear to be based on the approximation that the temperature is uniform within the fire compartment.

For known combustion characteristics of the fire load, the gas temperature-time curve of the postflashover compartment fire can be calculated for a particular compartment from the energy and mass balance equations with regard to the size, geometry and ventilation, and to the thermal properties of the structures enclosing the compartment - Fig. 16 [29-39].

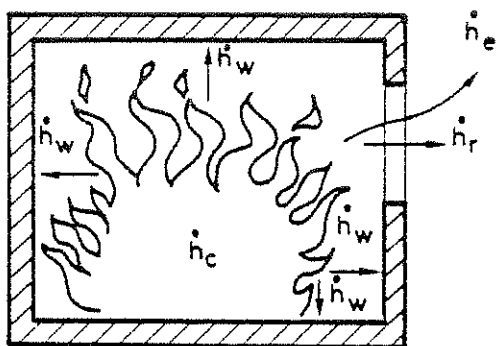

Fig. 16 Energy balance of a compartment fire

The energy balance equation of a fire compartment reads

$$\dot{h}_c = \dot{h}_e + \dot{h}_r + \dot{h}_w + \dot{h}_g \quad (2)$$

where  $\dot{h}_c$  = rate of heat release due to the combustion of the fuel (fire load),  $\dot{h}_e$  = energy removed per unit time by change of hot gases against cold air,  $\dot{h}_r$  = energy removed per unit time by radiation through the openings,  $\dot{h}_w$  = energy removed per unit time by heat transfer to the surrounding structures, and  $\dot{h}_g$  = energy stored per unit time within the fire compartment - usually negligible. The corresponding mass balance of the fire compartment is described by the equation

$$\dot{m}_f = \dot{m}_{air} + \dot{m}_p \quad (3)$$

where  $\dot{m}_f$  = mass outflow of hot gases,  $\dot{m}_{air}$  = mass inflow of air, and  $\dot{m}_p$  = rate of fuel pyrolysis.

As a simplification, postflashover compartment fires can be described by two types of behaviour - ventilation controlled



or fuel bed controlled [40]. For the first type, the combustion during the active stage of the fire is controlled by the ventilation of the compartment with the burning rate approximately proportional to the air supply through the openings and does not depend on the amount, porosity and particle shape of the fuel in any decisive way. For the second type, the combustion is mainly controlled by the properties of the fuel and is fairly independent of the air supply through the openings. The boundary between the two types of fire behaviour is not clearly defined.

Fig. 17 illustrates the two types of compartment fires in a diagram, giving the rate of enthalpy release during the fire process versus time for two types of fuel [34]. In the figure,  $\dot{h}_p$  denotes the potential rate of change of enthalpy of the gas, pyrolyzed from the fuel, i.e. the maximum fuel enthalpy release rate that would occur under ideal burning conditions. The term  $\dot{h}_s$  denotes the rate of heat release for stoichiometric combustion. For given compartment,  $\dot{h}_s$  is primarily a function of the ventilation factor  $A\sqrt{h}$  and the gas temperature and only slightly dependent on the type of fuel. The actual enthalpy release rate  $\dot{h}_c$  will be the lesser of  $\dot{h}_p$  and  $\dot{h}_s$ , reduced by a factor of maximum combustion efficiency  $b_p$ , which corrects for incomplete mixing, i.e.

$$\dot{h}_c = \text{lesser of } \begin{cases} \dot{h}_p b_p \\ \dot{h}_s b_p \end{cases} \quad (4)$$

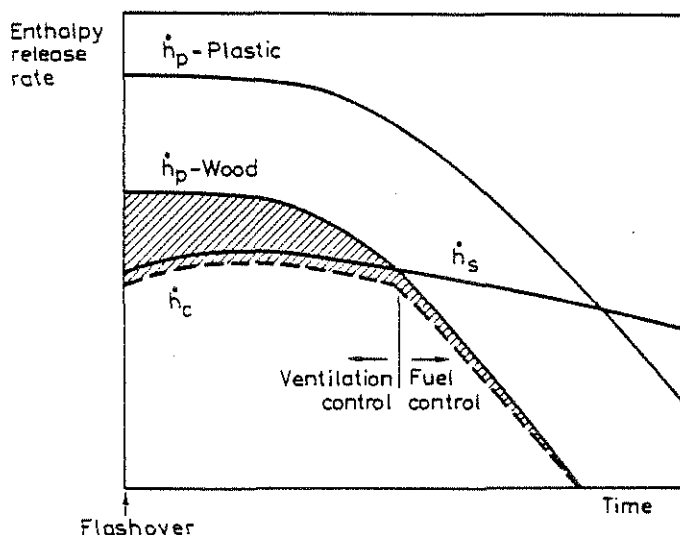

Fig. 17 Possible rates of enthalpy release in a postflashover compartment fire versus time for two types of fuel [34]

Fig. 17 shows two compartment fires with  $\dot{h}_p > \dot{h}_s$  at flashover which means that the fires start as ventilation controlled. At a decreasing rate of pyrolysis during the fire, the  $\dot{h}_p$  curve may cross the  $\dot{h}_s$  curve after some time. At this point, the fire changes to be fuel controlled from then on. For  $\dot{h}_p > \dot{h}_s$ , more fuel is pyrolyzed within the fire compartment than can be burnt inside it. The difference  $(\dot{h}_p - \dot{h}_s)$ , shown hatched in the figure for the wood fuel fire, represents the excess pyrolysates, released from the compartment. For fuels with a high rate of pyrolysis, which is typical for flammable liquids and many plastic fuels, these excess pyrolysates can give rise to a considerable fire hazard outside the fire compartment, for instance, in corridors or at facades - Fig. 18.



Fig. 18 Fire hazard outside a facade at a compartment fire in a multi-storey building

The practical use of the energy and mass balance equations of the postflashover compartment fire is facilitated by access to well-documented computer programmes, e.g., see [37]. A closed-form approximation, arranged to suit hand calculations, is presented in [38].

The available methods can be used for preparation of design aids for practical application. The gas temperature-time curves in Fig. 19 - cf. [31, 41-43] - exemplify such design

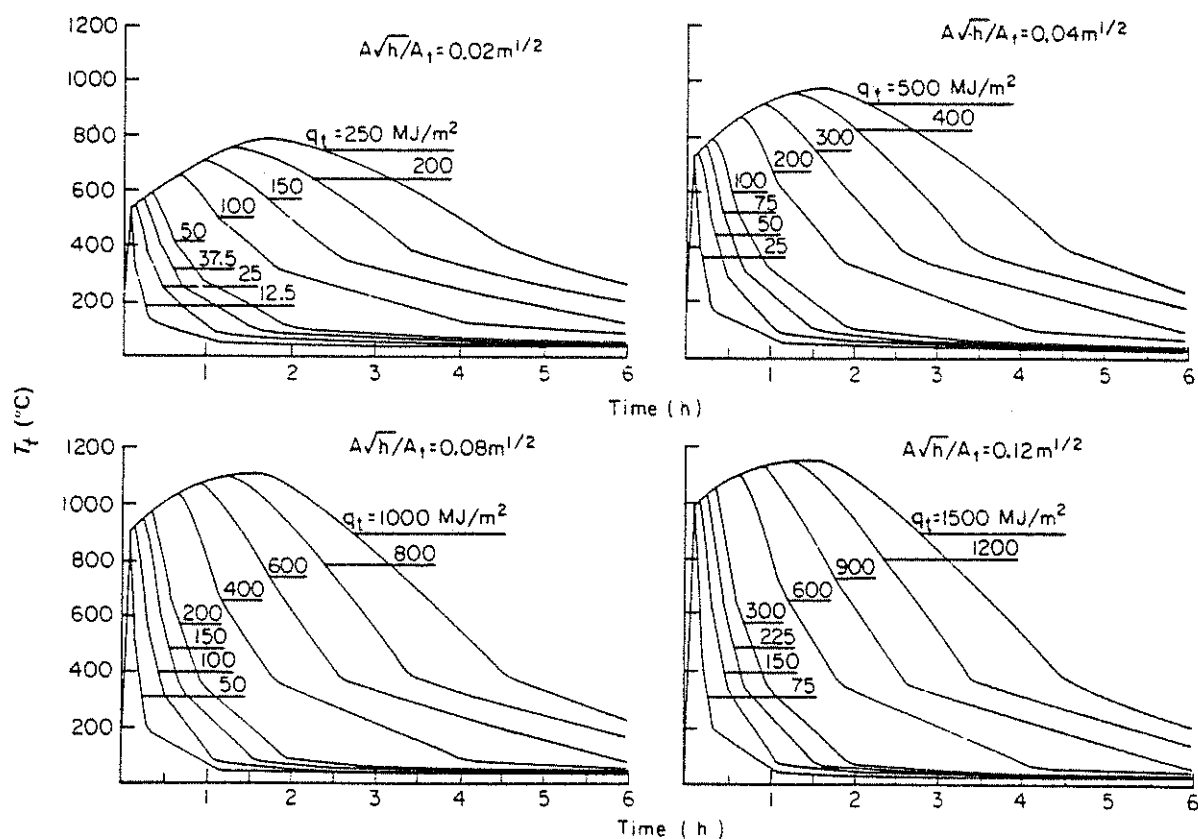

Fig. 19 Example of gas temperature-time curves  $T_t$ - $t$  of postflashover compartment fires for different values of the fire load density  $q_t$  and the opening factor  $A\sqrt{h}/A_t$ . Fire compartment, type A - from authorized Swedish Standard Specifications [31, 41-43]

aids for an analytical design of load bearing structures and partitions, exposed to a natural compartment fire. The curves are approved by the National Swedish Board of Physical Planning and Building for a general practical application.

Variables for the diagrams are the fire load density  $q_t$  per unit area of bounding surfaces of the compartment ( $\text{MJ m}^{-2}$ ), and the ventilation characteristics of the compartment, expressed by the opening factor  $A\sqrt{h}/A_t$  ( $\text{m}^{\frac{1}{2}}$ ), where  $A$  = total area of window and door openings ( $\text{m}^2$ ),  $h$  = mean value of the height of window and door openings, weighted with respect to

each individual opening area (m), and  $A_t$  = total interior area of the surfaces, bounding the compartment, opening area included ( $m^2$ ). The diagrams apply to a fire compartment with specified thermal data for the bounding structures - fire compartment type A. Fire compartments with deviating thermal data approximately can be transferred to the fire compartment type A by using modified values of the fire load density and the opening factor [41-43].

The models available are applicable to fire compartments of a size representative of dwellings, ordinary offices, schools, hospitals, hotels and libraries. For fire compartments with very large volumes, e.g., industrial buildings and sports halls, the curves give an unsatisfactory description of the real fire exposure. For such compartments, a preflashover fire may locally expose a structural member - for instance, a beam, a column or a frame - more or less severely than would be the case, if the design is based on available models of the postflashover compartment fire. At present, no validated models are available for a phenomenologically correct representation of the fire exposure, as concerns fire compartments with a very large volume. In [44], a preliminary investigation is presented which includes a non-uniform model of the postflashover compartment fire - in its present version consisting of 29 subvolumes and 60 surface elements on the boundary of the compartment. For a practical application to fire compartments of a very large volume, the model has to be supplemented by a model, describing the fire growth and the related energy release in the subvolumes, as well as by an internal flow model.

The internationally prevailing fire design of load bearing structural elements and partitions relates to national classification systems with direct application of results of standard fire resistance tests. In such a test, the specimen is exposed in a furnace to a temperature rise according to the relationship

$$T - T_0 = 345 \log_{10} (8t + 1) \quad (5)$$

where  $t$  = time (minutes),  $T$  = furnace temperature at time  $t$  ( $^{\circ}\text{C}$ ), and  $T_0$  = furnace temperature at time  $t = 0$  ( $^{\circ}\text{C}$ ). When applying results of standard fire resistance tests in a practical design, it is important to consider that the test does not represent the real fire exposure in a building, nor does it model the behaviour of the structural element as a part of an assembly in a building. Standard fire resistance tests only grade structural members, and the building codes and regulations then require different grades of members according to the circumstances.

In order to utilize the results of fire resistance tests in a structural design, based on actual compartment fire characteristics, the concept equivalent time of fire exposure was introduced. The concept can be described as a means of directly transforming heating by exposure in a natural compartment fire to heating by exposure according to the standard fire resistance test - Fig. 20. The equivalent time of fire exposure  $t_e$  then is defined as that length of the heating period in a standard fire resistance test which gives the same decisive effect on the structural member with respect to failure as the complete process of a natural fire. For a load bearing structural element then the minimum load bearing capacity  $R_{\min}$  is the decisive factor, defined alternatively as a critical value of a maximum deflection, a maximum rate of deflection or a maximum temperature for the structural element.

At present, a validated information is available for a theoretical determination of the equivalent time of fire exposure for unprotected and protected steel structures and for reinforced concrete beams with a bending failure, introduced by yielding in the reinforcement [42, 43, 45-47]. For other types of load bearing structural elements and for partitions, there are very few studies reported on the concept.

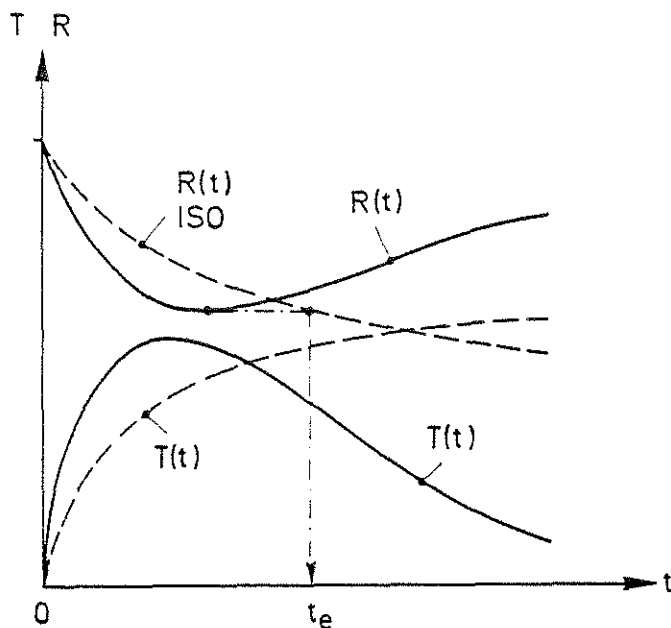

Fig. 20 Definition of equivalent time of fire exposure  $t_e$ . Full-line curves apply to a natural fire exposure, dash-line curves to a thermal exposure according to the standard fire resistance test, Eq. (5). T = temperature, R = load bearing capacity, t = time

## 2. Reaction to Fire of Materials

Traditionally, efforts to increase the fire safety in buildings have been directed towards requirements on structural components and - to a lesser extent - also to building materials. Furnishings and other non-structural features of buildings have until recent time remained essentially non-regulated. It is now widely recognized that an increase in human fire safety levels requires an assessment of the role of furnishings and other building contents. Consumer demands in a number of countries have resulted in efforts to control the flammability of furnishing by statutory or non-statutory requirements.

Especially important are those products which are capable on their own of converting a fire in one part of a room into a



general flashover - either because of their high thermal energy contents (upholstered furniture, large pieces of furniture made of plastics, mattresses), or because of their large surface areas (wall and ceiling decorations, large curtains).

In [48], the following possible requirements are formulated for the flammability and heat release of furniture and single objects in a compartment:

- \* A product should not be ignitable by an ignition source deemed to correspond to accidental sources common to a particular occupancy.
- \* The rate of heat release by a burning object should be assessed in relation to the rate causing flashover.
- \* If flashover cannot be prevented, the time to flashover should be long enough for people to escape.

Analogous requirements are given for linings and other materials of large area.

The fire hazard of a preflashover situation may be considered in terms of a series of probabilities which depend on

- \* presence of ignition sources,
- \* presence of products,
- \* product fire performance properties,
- \* environmental factors,
- \* presence of people,
- \* presence/operation of detection and suppression devices, and
- \* availability of escape.

In the area of internal linings, laboratory fire test methods are now actively being designed which measure the quantitative response of a material to specified fire exposure situations. Examples are the "reaction to fire" tests being developed within ISO/TC92. By operating at a number of exposure levels,

these tests will provide a comprehensive, quantitative description of basic fire performance characteristics - ignitability, surface spread of flame, rate of heat release, smoke density.

In a long time view, the practical use of the results of such small scale tests to predict the fire hazard should be based on a fundamental and scientific approach. Fig. 21 outlines the general structure of such an approach [49].

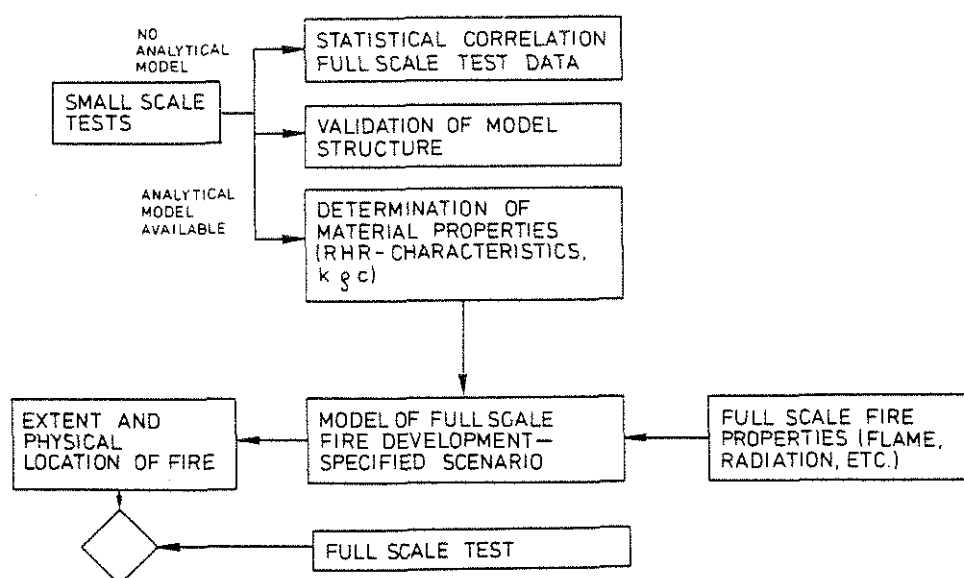

Fig. 21 Combination of basic property tests and mathematical models for assessing the contribution of a tested product to the overall fire safety [49]

If no analytical model of a small scale test is available, the test results have to be directly statistically correlated to full scale test data. If a validated analytical model of a small scale test exists, important material characteristics controlling the fire growth can be given quantitative values, which then can be used as input data in analytical models of the full scale preflashover compartment fire for specified scenarios. With such preflashover models at hand, supported and validated by full scale tests, it should be possible to

predict the time variation of the extent and physical location of a compartment fire at different environmental conditions.

The related life safety problem then must be approached by methodologies now being used within a number of other sectors for assessing efficiency, sensitivity to disturbance and reliability in complicated systems. Examples of analytical tools are probability theory, variance analysis, mathematical programming (linear, dynamic), decision analysis, systems simulation.

Mathematical modelling as a tool for practical application of results of small scale reaction to fire tests are now being subjected to a study within ISO/TC92. The ISO Technical Report TR 6585 "Fire Hazard and Design and Use of Fire Tests", October 1979 then is an introductory guidance document. Other important basic documents within the area are [48] by Thomas and a series of review papers on correlation studies, recently published by Quintiere [50]. One of the major problems in the study probably will be to strike a proper balance between the need for reasonably quick answers and the need for modelling accuracy. A short term goal may be a predictive model of whether or not flashover will occur for a given set of initial conditions, and, if so, how long after ignition it will occur.

In a recent paper [51], Magnusson and Sundström present a computational procedure to correlate the process of a full scale room fire test for combustible linings and the results from small scale reaction to fire tests with respect to ignitability and rate of heat release. The procedure requires that the heat release measurement response time of the full scale test room is evaluated and for a specific material linked to results from the ignitability test. From the same test, a value of the thermal inertia of the material must be calculated. Results of a small scale rate of heat release test can then be used as input data to an uncomplicated mathematical expression, essentially describing the full scale test fire as a concurrent

flame spread phenomenon. The expression was derived by a statistical modelling of the full scale test process using regression analysis.

An illustration of the ability of the procedure is shown by Fig. 22. It applies to a wall and ceiling lining and gives for three different types of board an experimental rate of heat release curve, obtained at a full scale room fire test (cross-marked values), compared with a calculated curve (point-marked curve), based on results of a small scale rate of heat release test.

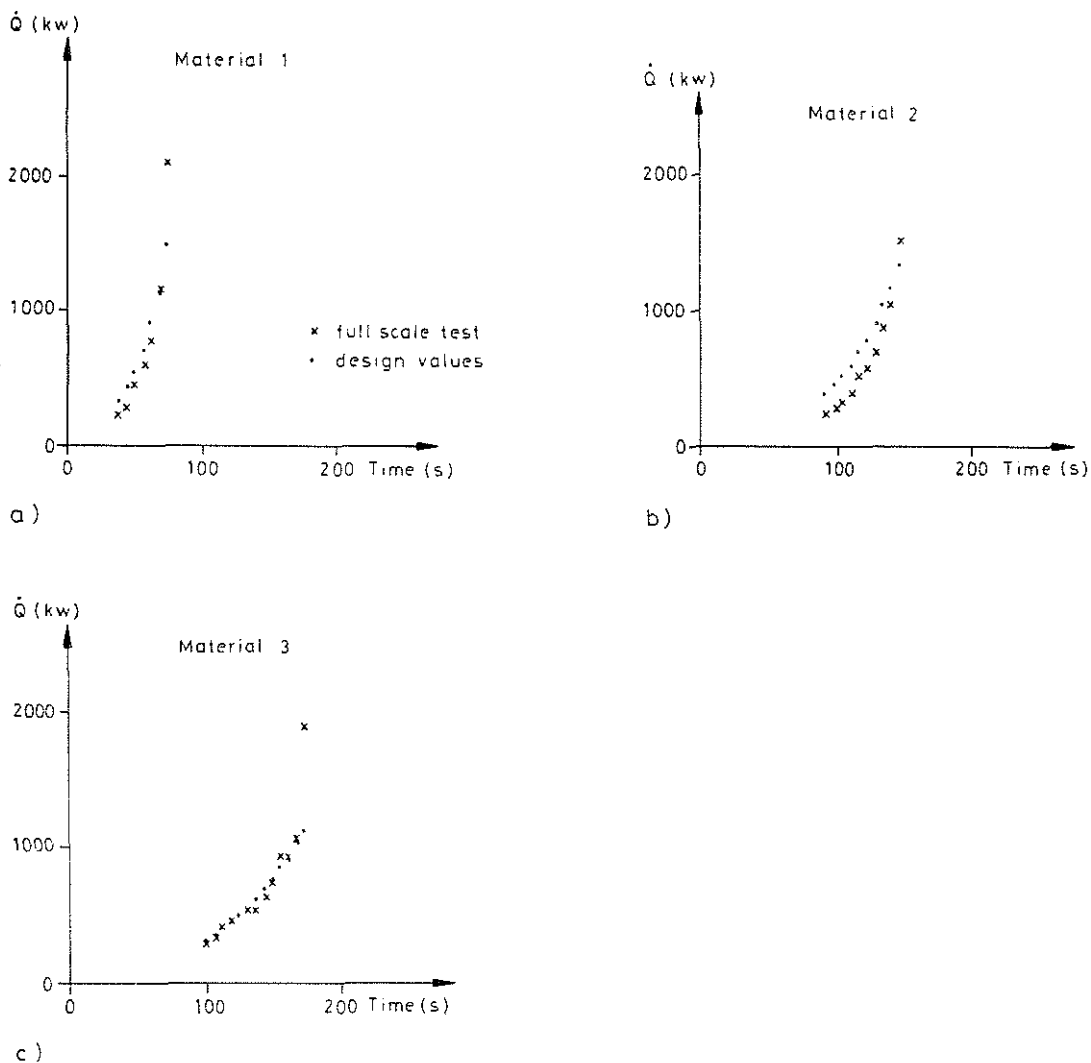

**Fig. 22** Experimental rate of heat release curves ( $\dot{Q}$ ) from full scale room fire test (x), compared with corresponding curves calculated from results of a small scale rate of heat release test (.). a) Insulating fibreboard (density  $250 \text{ kg}\cdot\text{m}^{-3}$ ), b) medium density fibreboard (density  $600 \text{ kg}\cdot\text{m}^{-3}$ ), c) particle board (density  $750 \text{ kg}\cdot\text{m}^{-3}$ ) [51]

### 3. Fire Spread Between Buildings

The fire spread between spatially separated buildings may result from one or more of the following [52]:

- \* Flying brands,
- \* convective heat transfer, and
- \* radiative heat transfer.

Flying brands may initiate secondary fire at substantial distances from the primary fire - up to 500 m. This type of fire spread can be minimized by proper roof construction, based on results of a relevant flying brand small scale test. Fire spread by convective heat transfer is likely only where windows overlook a non-fire-resistive roof of an adjacent building. The risk of fire spread by thermal radiation can be limited by sufficient distance between neighbouring buildings.

Analytical models are available for a calculation of the minimum distance between houses which, under different conditions, can be judged safe with respect to prevention of fire spread from house to house either by thermal radiation alone or by thermal radiation in combination with flame [49, 52 - 57].

At a fully developed fire in a house within, for instance, a small house area, an adjacent house will be exposed to a thermal radiation consisting of one part  $P_1$ , given by the radiation through the window openings from the fire within the fire compartment, and of one part  $P_2$ , given by the flames emerging through the windows - Fig. 23. Ordinarily, then the first type of radiation predominates.

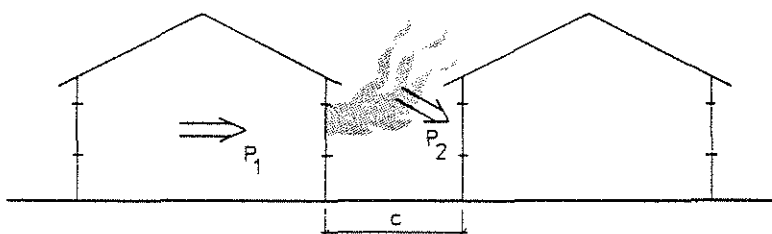

Fig. 23 Radiation from a building in fire to an adjacent building

Somewhat simplified, the total radiation  $P_1 + P_2$  is a function of

- \* the fire load density  $q_t$  of the house in fire (the fire compartment),
- \* the opening factor  $A\sqrt{h}/A_t$  of the fire compartment,
- \* the thermal properties of the structures surrounding the fire compartment,
- \* that part  $\gamma_p$  of the total opening area, from which radiation is emitted towards the adjacent house, and
- \* the distance  $c$  between the house in fire and the adjacent house.

If the exterior walls of the fire compartment are made of combustible material - wood - the fire behaviour and contribution of these structures has to be included as an additional important influence.

In a more accurate design, the detailed characteristics of the window openings (number, height, width, location), the geometry in plane and elevation, and the relative site of the houses must be considered, too.

A complete analytical model for a determination of the spatial separation of buildings to prevent fire spread includes three sub-models, viz.

- \* a model for the postflashover compartment fire, giving the gas temperature-time curve and the geometry and temperature of the external flames,
- \* a model, describing the radiation within an area of buildings at a fire in a single building, and
- \* a model, evaluating the time curve of the radiation on the adjacent building with respect to ignition of decisive combustible materials.

Fig. 24 shows a flow diagram, describing the complete design procedure. The ability of available design models is illustrated by Fig. 25, giving the calculated maximum radiation at a specified level of the exposed facade of house II at a defined fire in house I [55]. The total radiation then is composed of the individual contributions from the three window openings a, b and c, as demonstrated in the figure.

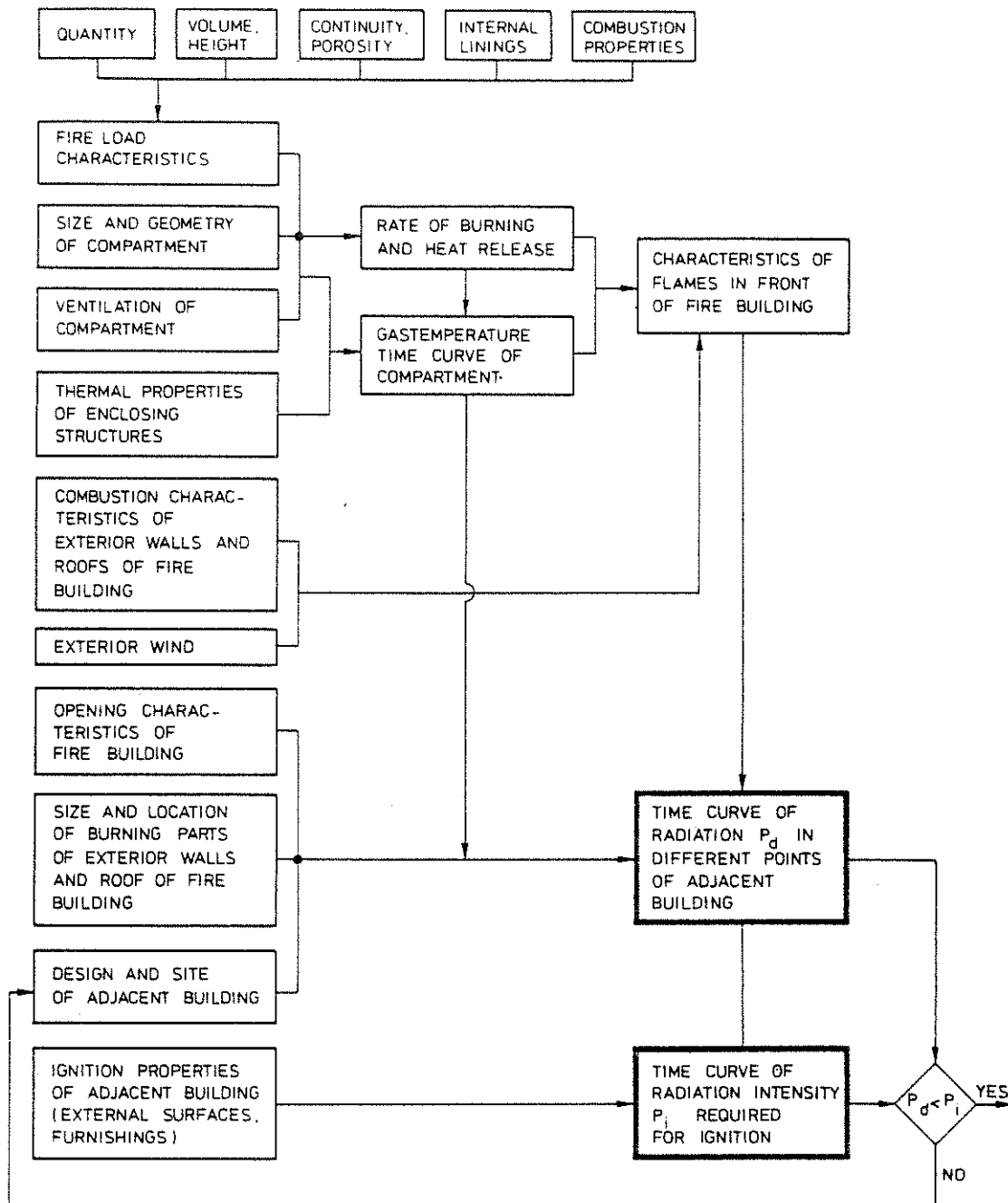
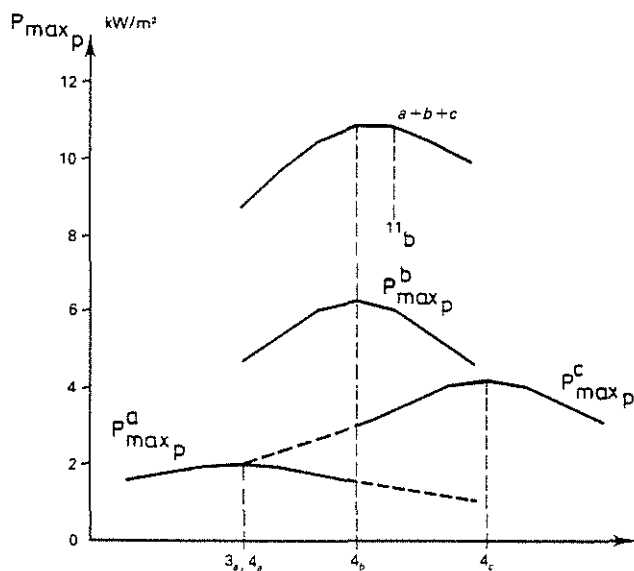
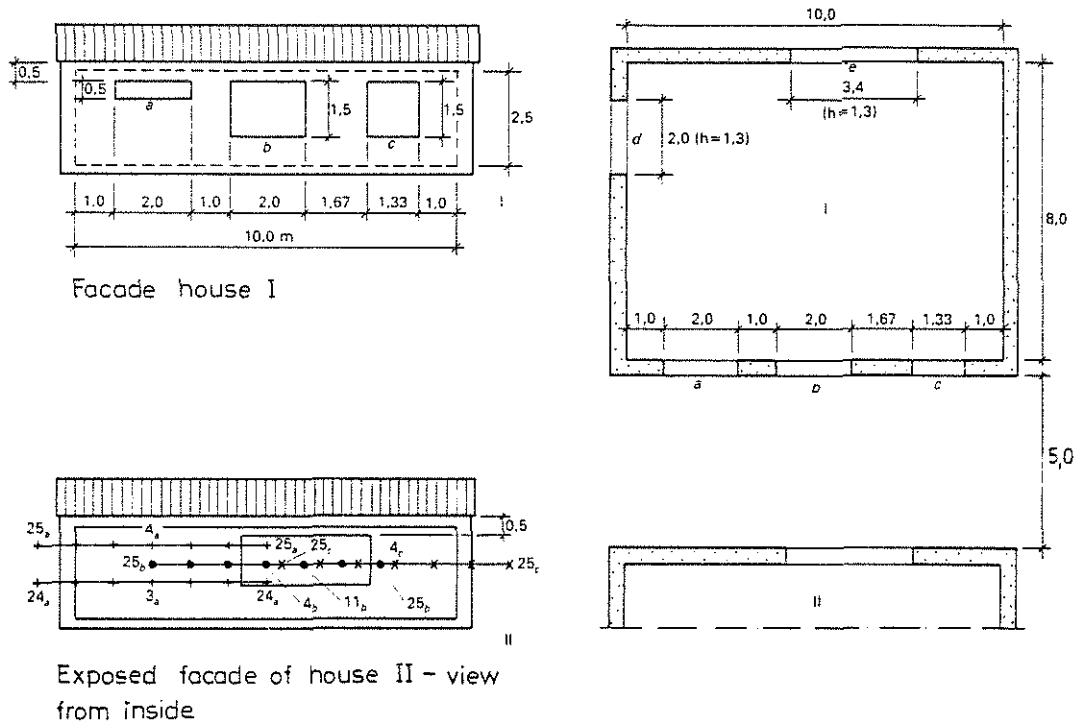

Fig. 24 Procedure of an analytical design of a small house area with respect to the risk of fire spread from one house to another [49]



**Fig. 25** Calculated maximum radiation  $P_{\max p}$  at a specified level  $25_b \dots 4_b \dots 25_b$ ,  $25_c \dots 4_c \dots 25_c$  of the exposed facade of house II at a defined fire in house I. Fire load density  $q_t = 125 \text{ MJ} \cdot \text{m}^{-2}$ . Enclosing structures of aerated concrete. The curves  $P_{\max p}^a$ ,  $P_{\max p}^b$  and  $P_{\max p}^c$  are giving the radiation from the window openings a, b and c, respectively, and the curve a+b+c the total radiation from all window openings [55]



The available analytical models also can be used for a calculation of simplified design diagrams. Fig. 26 exemplifies this by a set of diagrams for a quick determination of the

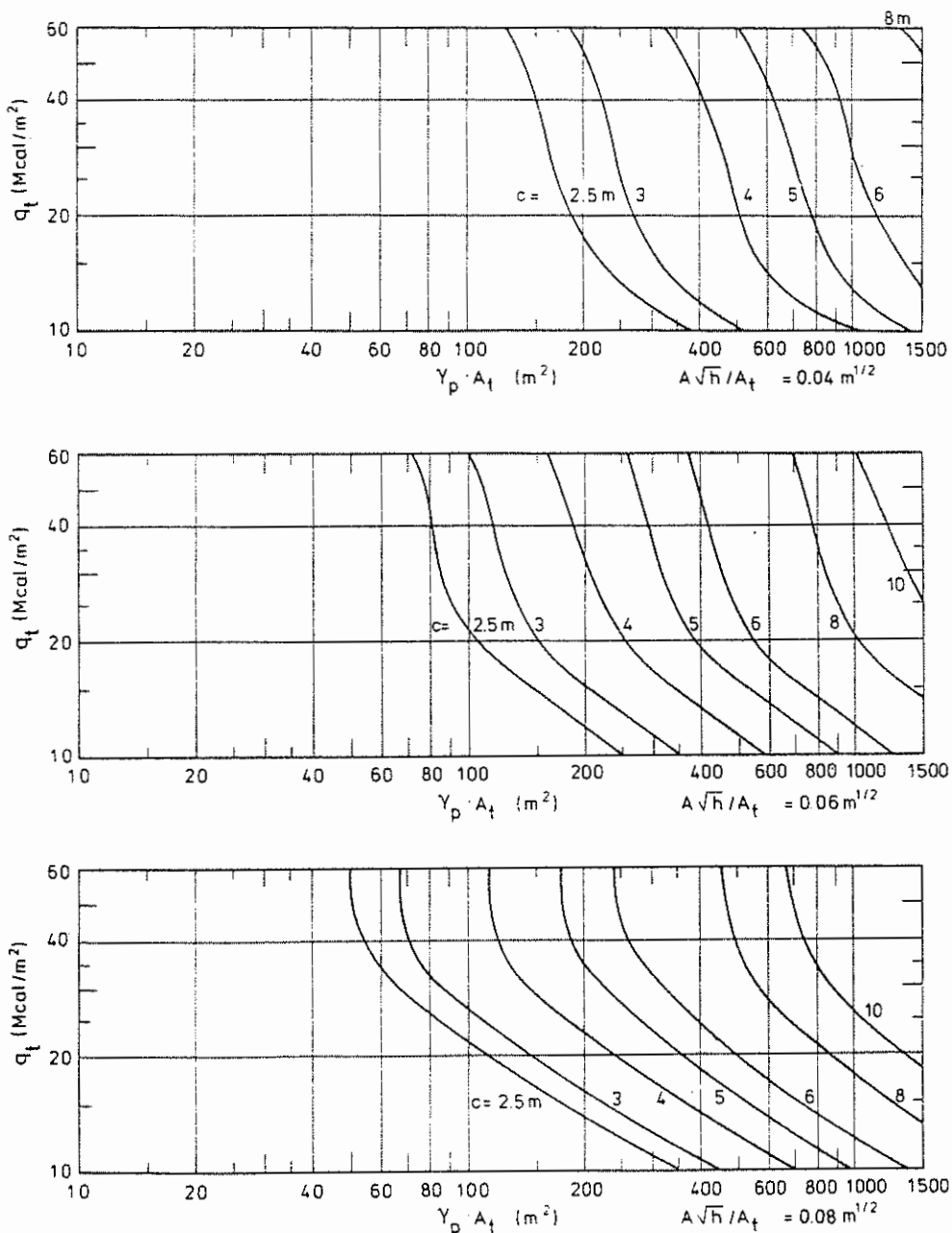

**Fig. 26** Minimum distance  $c$  between parallel small houses as a function of the fire load density  $q_t$  (Mcal per m<sup>2</sup> surrounding surface), opening factor  $A\sqrt{h}/A_t$  (m<sup>1/2</sup>) and the parameter  $\gamma_p$ , defining the ratio between the radiation opening area and the total opening area of the house in fire. Enclosing structures of ordinary concrete [57]

required minimum distance  $c$  between parallel small houses as a function of the fire load density  $q_t$ , the opening factor  $A\sqrt{h}/A_t$  and the parameter  $\gamma_p$ , defining the radiation area of the window openings of the house in fire [57]. The diagrams apply to small houses with surrounding structures of concrete.

#### 4. Fire Behaviour of Building Structures

During the last ten years, important progress has been made in the development of analytical and computation methods for the determination of the behaviour and load bearing capacity of building structures and structural members exposed to fire. Today, an analytical design can be completed for most cases, as concerns fire exposed steel structures. Validated material models for the mechanical behaviour of concrete under transient high-temperature conditions [58, 59] and thermal models for a calculation of the charring rate in wood exposed to fire [60-62], derived during recent years, have significantly enlarged the area of application of analytical design. To aid this application, design diagrams and tables have been computed and published, giving directly, on the one hand, the temperature state of the fire exposed structure, and on the other, a transfer of this information to the corresponding load bearing capacity of the structure - cf., for instance, [42, 43, 53, 63-75].

A fragmentary illustration of the ability of available models and connected computer programmes for a calculation of the thermal and mechanical behaviour of fire exposed structures is presented in Fig. 27 and 28. Fig. 27 then shows computed temperature-time curves for two points on void surface and for the void air in a hollow concrete slab, thermally exposed from below according to the standard fire resistance test [76]. The full-line curves are the result of an accurate determination with the heat transfer in the void taken into consideration. The dash-line curves give the corresponding temperature history, if the void is assumed to be a perfect insulator - an approximation, sometimes applied in the literature. The

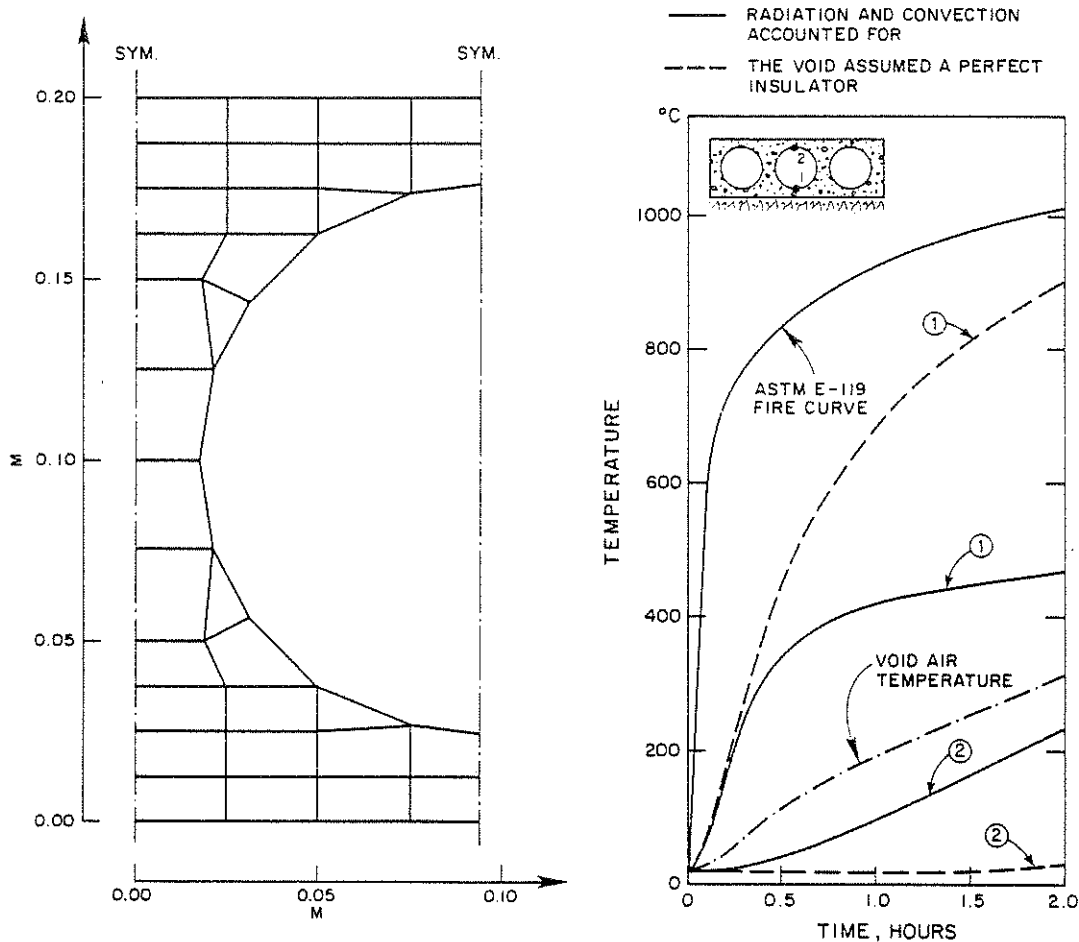

Fig. 27 Calculated temperature histories for two points of void surface, 1 and 2, and for void air in a hollow concrete slab, thermally exposed from below according to the standard fire resistance test [76]

predicted response for the two cases differs considerably, particularly at high temperatures. The curves have been computed by the finite element computer programme TASEF-2 [77] and the finite element mesh used is shown in the figure.

Fig. 28 presents the time curves of the restraint force, calculated by the computer programme CONFIRE [78] for a simply supported, concrete plate strip at different permissible, axial expansions  $\Delta L = 0, 2, 4$  and  $6$  mm, followed by a complete restraint. The plate strip is thermally exposed from below

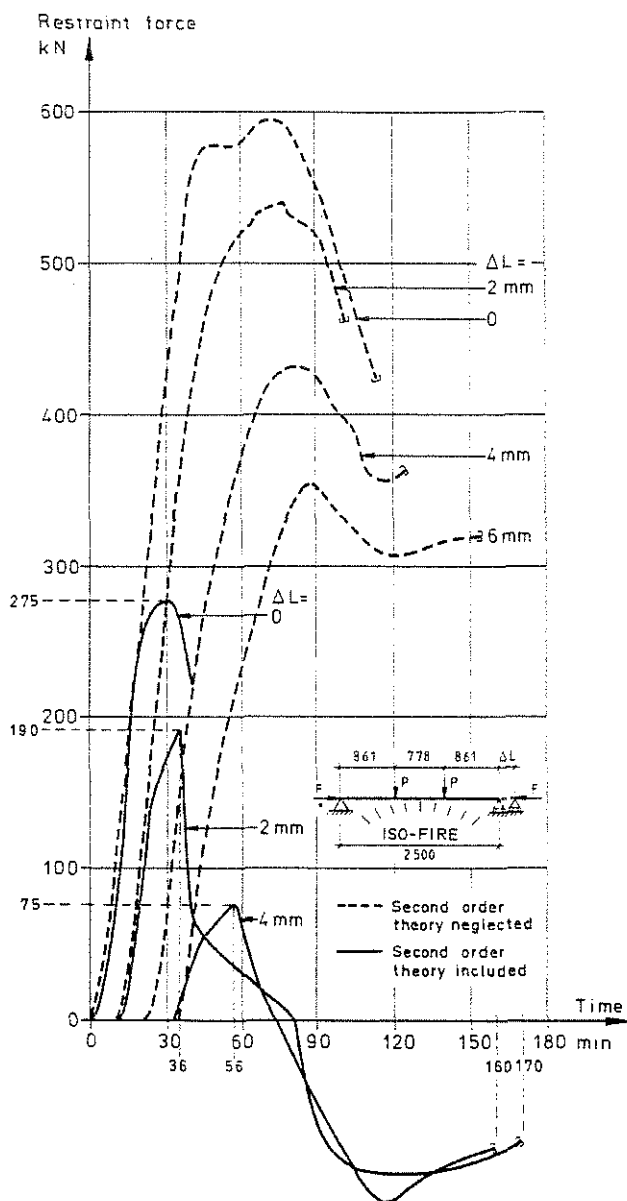

Fig. 28 Calculated restraint force  $F$  for a simply supported, concrete plate strip at different permissible, axial expansion  $\Delta L$ , followed by a complete restraint. Thermal exposure from below according to the standard fire resistance test [78, 79]

according to the standard fire resistance test. The second order effects are included in the full-line curves but neglected in the dash-line curves. The great difference between the two sets of curves emphasizes the necessity of including these effects for a structure with this kind of fire behaviour.

The most recent trend in the development of the structural fire design is to adopt the modern loading and safety philosophy and include a probabilistic approach, based on either a system of partial safety coefficients (practical design format) or the safety index concept [49, 75, 80-87]. For an everyday design, a direct application of the safety index concept then is too cumbersome and the more simplified practical design formats have to be used.

The fundamental components of such a reliability based structural fire design are

- \* the limit state conditions,
- \* the physical model,
- \* the practical design format, and
- \* deriving the safety elements.

Depending on the type of practical application, one, two or all of the following limit state conditions apply:

- \* Limit state with respect to load bearing capacity,
- \* limit state with respect to insulation,
- \* limit state with respect to integrity.

For a load bearing structure, the design criterion implies that the minimum value of the load bearing capacity  $R(t)$  during the fire exposure shall meet the load effect on the structure  $S$ , i.e.

$$\min\{R(t)\} - S \geq 0 \quad (6)$$

The criterion must be fulfilled for all relevant types of failure. The requirements with respect to insulation and integrity apply to separating structures. The design criterion regarding insulation implies that the highest temperature on the unexposed side of the structure -  $\max\{T_g(t)\}$  - shall meet the temperature  $T_{cr}$ , acceptable with regard to the require-

ment to prevent a fire spread from the fire compartment to an adjacent compartment, i.e.

$$T_{cr} - \max\{T_s(t)\} \geq 0 \quad (7)$$

For the integrity requirement, there is no analytically expressed design criterion available at present. Consequently, this limit state condition has to be proved experimentally, when required, in either a fire resistance test or a simplified small scale test.

The physical model comprises the deterministic model, describing the relevant physical processes of the thermal and mechanical behaviour of the structure at specified fire and loading conditions. Fig. 29 presents the physical model for an analytical fire design of load bearing structures, based on the natural compartment fire concept. The design starts by a determination of the fire exposure, using the characteristics

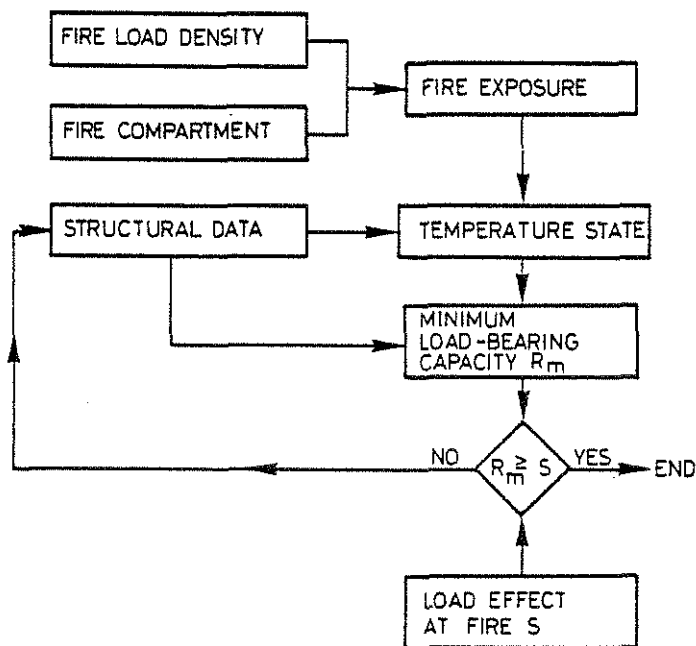

Fig. 29 Physical model for a structural fire engineering design

of the fire load density and the fire compartment as input data. In the next step, the fire exposure is transferred analytically to transient temperature fields in the exposed structure and then a determination is carried out of the time variation of the load bearing capacity  $R(t)$ . A comparison between the minimum value  $R_m$  of the load bearing capacity  $R(t)$  during the relevant fire process and the load effect  $S$  decides whether the structure can fulfil its required function or not during the fire exposure, as specified by the limit state condition according to Eq. (6).

Fig. 30 summarizes the corresponding practical design format calculation, based on partial safety factors, for a fire exposed load bearing structure. From the design fire load density  $q_d$  and the geometrical, ventilation and thermal characteristics of the fire compartment, the design fire exposure is determined either by energy and mass balance calculations or from a systematized design basis. Together with the structural design data, the design thermal properties and the de-

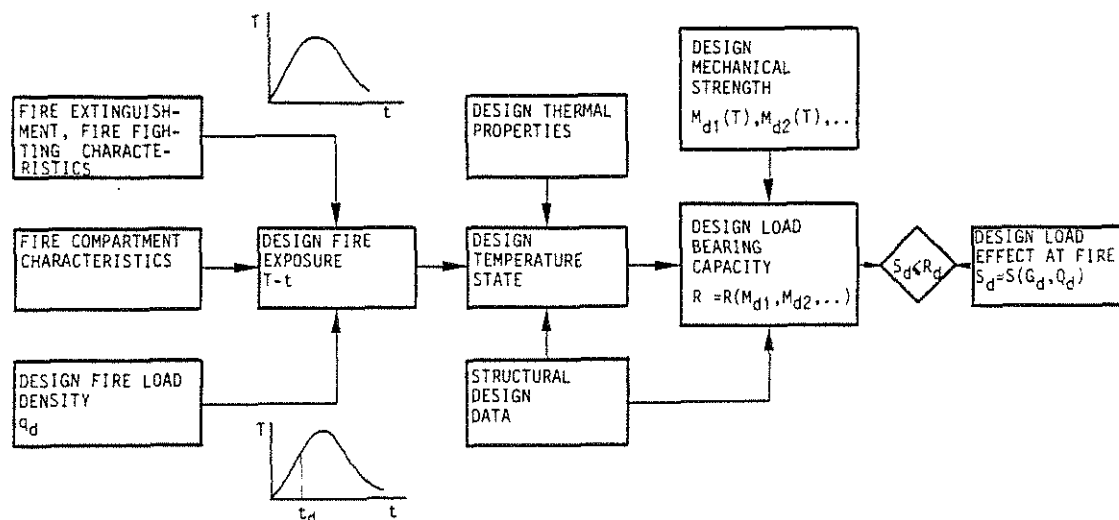

Fig. 30 Procedure for a practical design format calculation of a load bearing structure, exposed to a natural compartment fire

design mechanical strength of the structural materials, the design fire exposure provides the design temperature state and the related design load bearing capacity  $R_d$  for the lowest value of the load bearing capacity during the relevant fire process.

The design format condition to be proved is

$$R_d - S_d \geq 0 \quad (8)$$

where  $S_d$  is the design load effect at fire. Depending on the type of practical application, the condition has to be verified for either the complete fire process or a limited part of it, determined by the time necessary for the fire brigade to attack the fire under the most severe conditions or by the design evacuation time for the building.

The probabilistic influences are considered by specifying characteristic values and related partial safety factors for the fire load density, such structural design data as imperfections, the thermal properties, the mechanical strength and the loading. The partial safety factors then are to be derived by a probabilistic analysis, based on a first order reliability method, with the following probabilistic effects taken into account:

- \* The uncertainty in specifying the loads and of the model, describing the load effect on the structure,
- \* the uncertainty in specifying the fire load and the characteristics of the fire compartment,
- \* the uncertainty in specifying the design data of the structure and the thermal and mechanical properties of the structural materials,
- \* the uncertainty of the analytical models for the calculation of the compartment fire, the heat transfer to and within the structure and its ultimate load bearing capacity,
- \* the probability of occurrence of a fully developed compartment fire,



- \* the efficiency of the fire brigade actions,
- \* the effect of an installed extinction system, and
- \* the consequences of a structural failure.

The functional requirements to be laid down for the fire design should be differentiated with respect to such aspects as the occupancy, the height and volume of the building, and the importance of the structure or structural member to the overall stability of the building. This can be done by, for instance, a system of safety classes with allocated failure probabilities, affecting the design strength. The effect of the probability of occurrence of a postflashover compartment fire, the fire brigade actions and an installed fire extinguishment system, if any, can be accounted for principally in the same way. An alternative solution is to include these influences in the determination of the design fire load density and the design fire exposure, as indicated in Fig. 30.

#### 5. Concluding Remarks

With the general trends of development, specified in the introduction, as a background, the primary aim for the presentation has been to demonstrate the rapidly expanding modelling capabilities within the field of fire research and design. The presentation has been limited to only a few problems, viz. the fire growth in a compartment, the fully developed compartment fire, the reaction to fire of materials, the fire spread between buildings, and the fire behaviour of building structures. There are many other problems or systems now being amenable to computer modelling, for instance, smoke movement in escape routes and multi-storey buildings, the interaction of sprinklers and a fire, the process of escape, and the systems approach to the overall fire safety of a building, in its most general form comprising human response models interacting with fire development models.

Mathematical modelling is a prerequisite for understanding the physical processes of fires and fire tests. In a long time view, the practical use of results of small scale fire tests to predict the fire hazard should be based on a fundamental and scientific approach, in which mathematical modelling is an important and decisive component. Mathematical models, of course, can be directly used in the practical design. Mathematical models can be applied to reconstruct the sequence of events in a disastrous fire. Another essential use is as an educational tool. Combined with sensitivity studies, mathematical models can be very helpful for an optimum choice of projects within a defined field of research at a given level of resources.

As a general summing up: With expanding modelling capabilities, the potential for a rational, reliability based fire design will increase in proportion.

#### References

- [1] P.H. Thomas, M.L. Bullen, J.G. Quintiere and B.J. McCaffrey, Flashover and Instabilities in Fire Behaviour. *Combustion and Flame* 38:159-171 (1980).
- [2] P.H. Thomas, Modelling of Compartment Fires. *Fire Safety Journal* 5:181-190 (1983).
- [3] T.E. Waterman, Room Flashover - Scaling of Fire Conditions. *Fire Technology* 5:52-58 (1969).
- [4] B. Hägglund, R. Jansson and B. Onnermark, Fire Development in Residential Rooms after Ignition from Nuclear Explosions. Report C 20016-D6(A3), National Defence Research Institute (FOA), Stockholm (1974).
- [5] T.E. Waterman, Room Flashover - Model Studies. *Fire Technology* 8:316-325 (1972).
- [6] B.J. McCaffrey, J.G. Quintiere and M.F. Harkleroad, Estimating Room Temperatures and the Likelihood of Flashover Using Fire Data Correlations. *Fire Technology* 17:98-119 (1981).
- [7] R. Friedman, Status of Mathematical Modelling of Fires. First Specialists Meeting of the Combustion Institute, University of Bordeaux (1981).

- [8] W.W. Jones, A Review of Compartment Fire Models. NBSIR 83-2684, National Bureau of Standards, Washington (1983).
- [9] S.E. Magnusson, Recent Developments in Mathematical Modeling of Fire Growth. Notes for a summary report to the CIB W14 meeting in Athens (1980).
- [10] J.G. Quintiere, Growth of Fire in Building Compartments. ASTM Symposium "Fire Standards and Safety", held at National Bureau of Standards, Gaithersburg, 5-6 April 1976. ASTM Special Technical Publication STP614, Washington (1977):131-167.
- [11] B. Hägglund, Simulating the Early Fire Growth in Residential Rooms. Report C 20352-A3, National Defence Research Institute (FOA), Stockholm (1980).
- [12] J.G. Quintiere, B.J. McCaffrey and M.F. Harkleroad, The Burning of Wood and Plastic Cribs in an Enclosure. NBSIR 80-2054, National Bureau of Standards, Washington (1980).
- [13] B. Hägglund, A Room Fire Simulation Model. Report C 20501-D6, National Defence Research Institute (FOA), Stockholm (1983).
- [14] L.Y. Cooper, On the Significance of a Wall Effect in Enclosures with Growing Fires. NBSIR 83-2730, National Bureau of Standards, Washington (1983).
- [15] B. Sundström and U. Wickström, Fire: Full Scale Tests. Technical Report SP-RAPP 1981:48, National Testing Institute, Borås (1981).
- [16] T. Tanaka, A Model of Fire Spread in Small Scale Buildings. Research Paper No. 84, Building Research Institute, Tokyo (1980).
- [17] T. Tanaka, A Model of Multiroom Fire Spread. NBSIR 83-2718, National Bureau of Standards, Washington (1983).
- [18] H.E. Mitler and H.W. Emmons, Computer Fire Code V. Home Fire Project, Technical Report No. 45, Harvard University, Cambridge, MA (1981).
- [19] J.A. Rockett, Modeling of NBS Mattress Tests with the Harvard Mark V Fire Simulation. Fire and Materials 6: 80-95 (1982).
- [20] J.G. Quintiere, An Approach to Modeling Wall Fire Spread in a Room. Fire Safety Journal 3:201-214 (1981).
- [21] G. Cox and N.C. Markatos, Turbulent Buoyant Heat Transfer in Enclosures Containing a Fire Source. Proceedings of the Seventh International Heat Transfer Conference in Munich, Vol. 6:373 (1982).
- [22] F.B. Clarke and J. Ottoson, Fire Death Scenarios and Fire Safety Planning. Fire Journal 70:20 (1976).

- [23] E.E. Zukoski, Development of a Stratified Ceiling Layer in the Early Stages of a Closed-room Fire. *Fire and Materials* 2:54-62 (1978).
- [24] L.Y. Cooper, A Mathematical Model for Estimating Available Safe Egress Time in Fires. *Fire and Materials* 6: 135-144 (1982).
- [25] B. Hägglund, Simulating the Smoke Filling in Single Enclosures. Report C 20513-D6, National Defence Research Institute (FOA), Stockholm (1983).
- [26] B. Hägglund, Hazardous Conditions in Single Enclosures Subjected to Fire - A Parameter Study. Report C 20524-D6, National Defence Research Institute (FOA), Stockholm (1983).
- [27] J.G. Quintiere, M. Birky, F. Macdonald and G. Smith, An Analysis of Smoldering Fires in Closed Compartments and Their Hazard Due to Carbon Monoxide. NBSIR 82-2556, National Bureau of Standards, Washington (1982).
- [28] T.Z. Harmathy and J.R. Mehaffey, Post-flashover Compartment Fires: A Review. *Fire and Materials* 7:49-61 (1983).
- [29] K. Kawagoe and T. Sekine, Estimation of Fire Temperature-Time Curve in Rooms. Occasional Report No. 11, Building Research Institute, Tokyo (1963) - K. Kawagoe, Estimation of Fire Temperature-Time Curve in Rooms. Research Paper No. 29, Building Research Institute, Tokyo (1967).
- [30] K. Ödeen, Theoretical Study of Fire Characteristics in Enclosed Spaces. Bulletin 19, Division of Building Construction, Royal Institute of Technology, Stockholm (1963).
- [31] S.E. Magnusson and S. Thelandersson, Temperature-Time Curves for the Complete Process of Fire Development - A Theoretical Study of Wood Fuel Fires in Enclosed Spaces. *Acta Polytechnica Scandinavica*, Ci 65, Stockholm (1970).
- [32] T.Z. Harmathy, A New Look at Compartment Fires. Part I, *Fire Technology* 8:196-217 (1972); Part II, *Fire Technology* 8:326-351 (1972).
- [33] S.E. Magnusson and S. Thelandersson, A Discussion of Compartment Fires. *Fire Technology* 10:228-246 (1974).
- [34] V. Babrauskas and R.B. Williamson, Post-flashover Compartment Fires. Report No. UCB FRG 75-1, Fire Research Group, University of California, Berkeley (1975) - Post-flashover Compartment Fires: Basis of a Theoretical Model. *Fire and Materials* 2:39-53 (1978).
- [35] P.H. Thomas, Some Problem Aspects of Fully Developed Room Fires. ASTM Symposium "Fire Standards and Safety", held at National Bureau of Standards, Gaithersburg, 5-6 April 1976. ASTM Special Technical Publication STP614, Washington (1977):112-130

- [36] B. Bøhm, Fully Developed Polyethylene and Wood Compartment Fires with Application to Structural Design. Technical University of Denmark, Copenhagen (1977) (with data supplement).
- [37] V. Babrauskas, COMPF2 - A Program for Calculating Post-flashover Fire Temperatures. Technical Note 991, National Bureau of Standards, Washington (1979).
- [38] V. Babrauskas, A Closed-form Approximation for Post-flashover Compartment Fire Temperatures. Fire Safety Journal 4:63-73 (1981).
- [39] B. Bøhm and S. Hadvig, Nonconventional Fully Developed Polyethylene and Wood Compartment Fires. Combustion and Flame 44:201-222 (1982).
- [40] P.H. Thomas, A.J.M. Heselden and M. Law, Fully-developed Compartment Fires - Two Kinds of Behaviour. Fire Research Technical Paper No. 18, Ministry of Technology and Fire Offices Committee, Joint Fire Research Organization, HMSO, London (1967).
- [41] National Swedish Board of Physical Planning and Building, Brandteknisk dimensionering (Fire Engineering Design). Comments on SBN (Swedish Building Code), No. 1, Stockholm (1976).
- [42] O. Pettersson, S.E. Magnusson and J. Thor, Fire Engineering Design of Steel Structures. Swedish Institute of Steel Construction. Publication No. 50, Stockholm (1976) (Swedish edition 1974).
- [43] O. Pettersson and K. Ödeen, Brandteknisk dimensionering - principer, underlag, exempel (Fire Engineering Design of Building Structures - Principles, Design Basis, Examples). Liber förlag, Stockholm (1978).
- [44] B. Bøhm, Non-uniform Compartment Fires. Report No. 1, Preliminary investigation of fully developed fires. Laboratory of Heating and Air Conditioning, Technical University of Denmark, Copenhagen (1983).
- [45] M. Law, A Relationship between Fire Grading and Building Design and Contents. Fire Research Note 877, Joint Fire Research Organization, Borehamwood, Herts. (1971).
- [46] P.H. Thomas and A.J.M. Heselden, Fully-Developed Fires in Single Compartments. A Co-Operative Research Programme of the Conseil International du Bâtiment, CIB Report No. 20, Fire Research Note 923, Fire Research Station, Borehamwood, Herts. (1972).
- [47] U. Schneider and A. Haksever, Bestimmung der äquivalenten Branddauer von statisch bestimmt gelagerten Stahlbetonbalken bei natürlichen Bränden. Institut für Baustoffkunde und Stahlbetonbau, Technische Universität, Braunschweig (1976).

- [48] P.H. Thomas, Testing Products and Materials for their Contribution to Flashover in Rooms. *Fire and Materials* 5:103-111 (1981).
- [49] S.E. Magnusson and O. Pettersson, Functional Approaches - An Outline. CIB Symposium "Fire Safety in Buildings: Needs and Criteria", held in Amsterdam 1977-06-02/03, CIB Proceedings, Publication 48:120-145 (1978).
- [50] J. Quintiere, An Assessment of Correlations Between Laboratory and Full-Scale Experiments for the FAA Aircraft Fire Safety Program - Part 1: Smoke, NBSIR 82-2508; Part 2: Rate of Energy Release in Fire, NBSIR 82-2536; Part 4: Flammability Tests, NBSIR 82-2525 (1982).
- [51] S.E. Magnusson and B. Sundström, Modeling of Room Fire Growth - Combustible Lining Materials. Submitted to the ASTM/SFPE Symposium on Application of Fire Science to Fire Engineering, Denver, Colorado, June (1984).
- [52] J.H. McGuire and G. Williams-Leir, Spread of Fire between Buildings. *Canadian Building Digest* 216, Division of Building Research, National Research Council of Canada, Ottawa (1981).
- [53] T.T. Lie, *Fire and Buildings*. Applied Science Publishers, London (1972).
- [54] B. Fredlund, S.E. Magnusson, L. Nilsson, O. Pettersson, S. Strandberg and S. Thelandersson, Fire Spread in Low Rise, High Density Areas of Small Houses. *Fire Research and Development News (FoU-brand)* 1:7-12 (1974).
- [55] B. Fredlund, S.E. Magnusson, L. Nilsson, O. Pettersson, S. Strandberg and S. Thelandersson, Skydd mot brandspridning inom småhusbebyggelse av lättbetong (Protection Against Fire Spread Within Dense Areas of Small Houses, Built of Aerated Concrete). Manual, Swedish Fire Protection Association, Stockholm (1977).
- [56] G. Williams-Leir, Program for Pocket Calculator to Derive Spatial Separations to Deter Fire Spread. Computer Program 44, Division of Building Research, National Research Council of Canada, Ottawa (1978).
- [57] B. Fredlund, O. Pettersson and S. Strandberg, Skydd mot brandspridning inom småhusbebyggelse i betong (Protection Against Fire Spread Within Dense Areas of Small Houses, Built of Ordinary Concrete). Report No. R80-1, Department of Structural Mechanics, Lund Institute of Technology (1980).
- [58] Y. Anderberg and S. Thelandersson, Stress and Deformation Characteristics of Concrete at High Temperatures. 2. Experimental Investigation and Material Behaviour Model. Bulletin 54, Division of Structural Mechanics and Concrete Construction, Lund Institute of Technology, Lund (1976).

- [59] U. Schneider, Ein Beitrag zur Frage des Kriechens und der Relaxation von Beton unter hohen Temperaturen. Institut für Baustoffe, Massivbau und Brandschutz der Technischen Universität Braunschweig, Heft 42, Braunschweig (1979).
- [60] B. Fredlund, Modell för beräkning av temperatur och fuktfördelning samt reducerat tvärsnitt i brandpåverkade träkonstruktioner (Mathematical Model of Wood Pyrolysis, Including Internal Moisture Transfer). Internal Report IR 79-2, Division of Structural Mechanics, Lund (1977, 1979).
- [61] R.H. White and E.L. Schaffer, Application of CMA Program to Wood Charring. Fire Technology 14:279-291 (1978).
- [62] S. Hadvig, Charring of Wood in Building Fires - Practice, Theory, Instrumentation, Measurements. Laboratory of Heating and Air-Conditioning, Technical University of Denmark, Copenhagen (1981).
- [63] O. Pettersson, Theoretical Design of Fire Exposed Structures. Bulletin 51, Division of Structural Mechanics and Concrete Construction, Lund Institute of Technology, Lund (1976).
- [64] The Institution of Structural Engineers, Design and Detailing of Concrete Structures for Fire Resistance. Interim Guidance by a Joint Committee of the Institution of Structural Engineers, The Concrete Society, London (1978).
- [65] B. Barthélémy and J. Kruppa, Résistance au Feu des Structures - Béton, Acier, Bois. Édition Eyrolles, Paris (1978).
- [66] P.L. Fruitet, Guide pour la Conception des Bâtiments à Structures en Acier. Office Technique pour l'Utilisation de l'Acier (OTUA), Paris (1978).
- [67] T.Z. Harmathy, Design to Cope with Fully Developed Fires. ASTM Symposium "Design of Buildings for Fire Safety". ASTM Special Technical Publication STP 685: 198-276, Washington (1979).
- [68] CSTB (Centre Scientifique et Technique du Bâtiment), Méthode de Prévision par le Calcul du Comportement au Feu des Structures en Béton. Document Technique Unifié, Paris (1980).
- [69] L. Twilt and J. Witteveen, Brandveiligheid Staalconstructies (Fire Resistance of Steel Structures). Staalcentrum Nederland (1980).
- [70] ACI (American Concrete Institute), Guide for Determining the Fire Endurance of Concrete Elements. Reported by ACI Committee 216, ACI 216R-81 (1981).
- [71] E.J. Thrane, Brandteknisk dimensjonering av bygningskonstruksjoner (Fire Engineering Design of Building Structures). Tapir forlag, Oslo (1981).

- [72] CEB (Comité Euro-International du Béton), Design of Concrete Structures for Fire Resistance. Appendix to the CEB Model Code, Bulletin d'Information N° 145, Paris (1982).
- [73] CTICM (Centre Technique Industriel de la Construction Métallique), Méthode de Prévission par le Calcul du Comportement au Feu des Structures en Acier. Revue Construction Métallique, N° 3, Paris (1982).
- [74] ECCS (European Convention for Constructional Steelwork), European Redommendations for the Fire Safety of Steel Structures - Level 1: Calculation of the Fire Resistance of Load Bearing Elements and Structural Assemblies Exposed to the Standard Fire. Technical Committee 3, Fire Safety of Steel Structures, Elsevier (1983).
- [75] Y. Anderberg, O. Pettersson, S Thelandersson and U. Wickström, Brandteknisk dimensionering av betongkonstruktioner (Fire Engineering Design of Concrete Structures). Manual (in preparation).
- [76] U. Wickström, A Numerical Procedure for Calculating Temperature in Hollow Structures Exposed to Fire. Report No. 79-3, Department of Structural Mechanics, Lund Institute of Technology (1979).
- [77] U. Wickström, TASEF-2, A Computer Program for Temperature Analysis of Structures Exposed to Fire. Report No. 79-2, Department of Structural Mechanics, Lund Institute of Technology (1979).
- [78] N.E. Forsén, A Theoretical Study on the Fire Resistance of Concrete Structures. FCB-SINTEF, Report STF65 A82062, Trondheim (1982).
- [79] Y. Anderberg and N.E. Forsén, Fire Resistance of Concrete Structures. Nordic Concrete Research, Publication No. 1:1.1-17 (1982).
- [80] S.E. Magnusson, Probabilistic Analysis of Fire Exposed Steel Structures. Bulletin 27, Division of Structural Mechanics and Concrete Construction, Lund Institute of Technology (1974).
- [81] U. Schneider, H. Bub and M. Kersken-Bradley, Structural Fire Protection Levels for Industrial Buildings. Presented at the 1980 Fall Convention, American Concrete Institute, San Juan, Puerto Rico (1980).
- [82] D. Hosser and U. Schneider, Sicherheitskonzept für brandschutztechnische Nachweise von Stahlbetonbauteilen nach der Wärmebilanztheorie. Institut für Bautechnik, Berlin (1980).
- [83] S.E. Magnusson and O. Pettersson, Rational Design Methodology for Fire Exposed Load Bearing Structures. Fire Safety Journal 3:227-241 (1980/81).



- [84] O. Pettersson, Reliability Based Design of Fire Exposed Concrete Structures. Contemporary European Concrete Research, Stockholm (1981).
- [85] DIN 18230, Baulicher Brandschutz im Industriebau. Vornorm, Teil 1 und 2, Berlin (1982).
- [86] CIB W14, A Conceptual Approach Towards a Probability Based Design Guide on Structural Fire Safety. Report of CIB W14 Workshop "Structural Fire Safety", Fire Safety Journal, in publication (1983).
- [87] D. Gross, Aspects of Stochastic Modeling for Structural Firesafety. Fire Technology 19:103-114 (1983).