



LUND UNIVERSITY

A complex multiplier with low logic depth

Berkeman, Anders; Öwall, Viktor; Torkelson, Mats

Published in:

[Host publication title missing]

DOI:

[10.1109/ICECS.1998.813933](https://doi.org/10.1109/ICECS.1998.813933)

1998

[Link to publication](#)

Citation for published version (APA):

Berkeman, A., Öwall, V., & Torkelson, M. (1998). A complex multiplier with low logic depth. In *[Host publication title missing]* (Vol. 3, pp. 47-50) <https://doi.org/10.1109/ICECS.1998.813933>

Total number of authors:

3

General rights

Unless other specific re-use rights are stated the following general rights apply:

Copyright and moral rights for the publications made accessible in the public portal are retained by the authors and/or other copyright owners and it is a condition of accessing publications that users recognise and abide by the legal requirements associated with these rights.

- Users may download and print one copy of any publication from the public portal for the purpose of private study or research.
- You may not further distribute the material or use it for any profit-making activity or commercial gain
- You may freely distribute the URL identifying the publication in the public portal

Read more about Creative commons licenses: <https://creativecommons.org/licenses/>

Take down policy

If you believe that this document breaches copyright please contact us providing details, and we will remove access to the work immediately and investigate your claim.

LUND UNIVERSITY

PO Box 117
221 00 Lund
+46 46-222 00 00

A Complex Multiplier with Low Logic Depth

Anders Berkeman, Viktor Öwall and Mats Torkelson

Department of Applied Electronics, Lund University

Box 118, SE-221 00 Lund, Sweden

Tel. +46 46 2229377, Fax. +46 46 129948

E-mail: Anders.Berkeman@tde.lth.se

Abstract

A complex multiplier has been designed for use in a pipelined fast fourier transform processor. The performance in terms of throughput of the processor is limited by the multiplication. Therefore, the multiplier is optimized to make the input to output delay as short as possible. A new architecture based on distributed arithmetic and Wallace-trees has been developed and is compared to a previous multiplier realized as a regular distributed arithmetic array. The simulated gain in speed for the presented multiplier is approximately 100%. For verification, the multiplier is currently under fabrication in a three metal-layer 0.5 μ CMOS process using a standard cell library.

1. Introduction

A pipelined Fast Fourier Transform (FFT) processor has been designed for use in an Orthogonal Frequency Division Multiplex (OFDM) system. Multiplication is often the most time-critical and area consuming operation in a digital signal processor. Therefore, effort has to be made to decrease the number of multipliers and to increase their speed. In the designed FFT processor the critical path consists of a complex multiplier in series with a butterfly performing addition and subtraction. A part of the FFT pipeline is shown in figure 1. Since the butterfly processors are much faster than the complex multiplier, the maximum clock frequency of the processor strongly depends of the multiplier delay.

This paper present a novel multiplier architecture based on distributed arithmetic and Wallace trees. The new architecture is compared to a multiplier realized as a regular array and the speed improvement is 100% while power consumption is decreased. The multiplier is fully parameterized, so any configuration of input and output wordlengths could be elaborated. Both the array and the tree multiplier are under fabrication on the same die and will be evaluated for speed and power consumption on return.

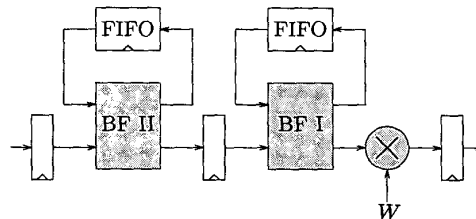

Figure 1: Part of the FFT processor pipeline. The butterfly processors are named "BF I" and "BF II". Shaded boxes are combinatorial logic.

2. The FFT processor

In the early versions of the FFT-processor, a complex array multiplier was used [2]. The array multiplier is a highly regular structure resulting in a minimal wire-length, which is important for high-speed design in sub-micron processes where wiring delay gives a significant contribution to the overall delay. However, in a process where cell delay dominates wire delay, the logic depth of the design is more important than regularity. In the complex array multiplier the logic depth is proportional to the input wordlength N . In the adder tree multiplier, on the other hand, the depth is proportional to $\log N$ [3]. Even for a small wordlength, this is a significant improvement. This also affects the amount of energy per operation for the multiplier. A lower logic depth will lead to a lower power consumption since the unnecessary switching activity is reduced.

A way to decrease the critical path of the FFT processor would be to pipeline the multiplier in two or more stages. However, due to the pipelined structure of the FFT processor, complexity of the controlling hardware would increase [1]. Furthermore, the word lengths of the data paths are wide due to the application of the processor and the usage of complex arithmetic. A multiplier in this application has between 44 and 52 inputs, and a pipeline register inserted somewhere in the middle of the multiplier would need a word length of more than a hundred bits. This would increase area, routing and clock

load and is not a preferable solution. Instead, the multiply operation is entirely combinatorial.

The FFT processor is implemented using the R2²DIF FFT-algorithm [1]. In this algorithm, every second multiplication can be exchanged to a multiply by $-j$, which for an 8192-point FFT leaves only six complex multipliers. This is to be compared to thirteen using a straightforward implementation. The multiplication by $-j$ is realized without a multiply by real-imaginary swap and negation of the imaginary part. This is the reason for two different butterfly processors, “BF I” and “BF II” in figure 1. By using this algorithm, the number of instantiated multipliers is minimized compared to an ordinary radix-2 FFT without any loss in throughput.

3. Multiplier algorithm

A complex multiplier calculates two inner products,

$$\begin{cases} Z_R = A_R W_R - A_I W_I \\ Z_I = A_R W_I + A_I W_R. \end{cases} \quad (1)$$

In the case of the FFT-processor, $W = W_R + jW_I$ are the twiddle-factors stored in a ROM. The wordlength of W_R and W_I is denoted M . According to equation (1), four real multiplications and two additions are needed.

There are two methods to decrease multiplication delay if it is assumed that multiplication is performed by summation of partial products, with the exception of logic minimization. The first is to reduce the number of partial products, and the second is to use a faster adder strategy to sum all the partial products together [3]. Both methods have been combined in the presented architecture.

Distributed arithmetic [4] was chosen as a means to reduce the number of partial products, and a Wallace tree adder was selected for adding the partial products together. By using distributed arithmetic, the complex multiplication is treated as two independent inner products Z_R and Z_I . Each of the inner products will be calculated using one distributed arithmetic multiplier, as explained in section 3. This should be compared to a multiplier realized using equation (1), in which case four real multipliers are needed.

As an alternative to distributed arithmetic, modified Booth-encoding was considered. However, as the number of partial products are about the same for both methods, modified Booth-encoding requires more logic gates to implement. This is due to that in the modified Booth algorithm, three variables have to be decoded to select the proper partial product. In a complex multiplier based on distributed arithmetic, a simple two-input xor-gate does the selection.

When using distributed arithmetic, the twiddle-factors have to be transformed from W_R and W_I to W_S and W_D , where

$$\begin{cases} W_S = W_R + W_I \\ W_D = W_R - W_I \end{cases} \quad (2)$$

This transformation does not cause any problems in the implementation, since the twiddle-factors are pre-calculated in the W_S and W_D format before realization. However, it is important that W_S and W_D are calculated using floating-point arithmetic before they are converted to fixed point. Otherwise, accuracy is reduced.

4. Mathematical background

This section gives a mathematical background to the operation of the multiplier. In the equations that follow a bit-variable is treated as a variable holding the arithmetic value 0 or 1. In this way bits can be used together with arithmetic variables and operators. If A is an N -bit fractional number in two’s complement, the value of A is calculated as

$$A = -a_0 + \sum_{i=1}^{N-1} a_i 2^{-i}. \quad (3)$$

By using the identity

$$A = \frac{1}{2} [A - (-A)] \quad (4)$$

and the rule for negating a two’s complement number

$$-A = \bar{A} + 2^{-(N-1)}, \quad (5)$$

equation (3) can be written as

$$A = -(a_0 - \bar{a}_0) 2^{-1} + \sum_{i=1}^{N-1} (a_i - \bar{a}_i) 2^{-i-1} - 2^{-N}. \quad (6)$$

Introduce $\alpha_0 = (\bar{a}_0 - a_0)$, and for $k \neq 0$, $\alpha_k = (a_k - \bar{a}_k)$. Note that all $\alpha_k \in \{-1, +1\}$. Using this notation, A can be written as

$$A = A' - 2^{-N}, \quad (7)$$

where

$$A' = \sum_{i=0}^{N-1} \alpha_i 2^{-i-1}. \quad (8)$$

The relationship between a_i and α_i is

$$\alpha_i = \begin{cases} +1, & \text{if } a_{i \neq 0} = 1 \text{ or } a_0 = 0 \\ -1, & \text{if } a_{i \neq 0} = 0 \text{ or } a_0 = 1 \end{cases} \quad (9)$$

Using this encoding the complex product can be written as

$$Z_R = \sum_{i=0}^{N-1} (W_R \alpha_{Ri} - W_I \alpha_{Ii}) 2^{-i-1} - (W_R - W_I) 2^{-N} \quad (10)$$

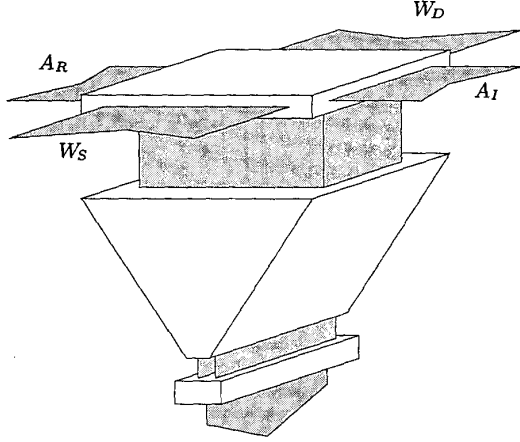

Figure 2: The multiplier for Z_R or Z_I . The complete complex multiplier consists of two of these. Partial inner product generator at top, adder tree in the middle and fast carry-lookahead adder at the bottom.

$$Z_I = \sum_{i=0}^{N-1} (W_I \alpha_{Ri} + W_R \alpha_{Ii}) 2^{-i-1} - (W_I + W_R) 2^{-N}. \quad (11)$$

The expression $W_I \alpha_{Ri} + W_R \alpha_{Ii}$ is for $i \neq 0$ examined in the following table.

α_{Ri}	α_{Ii}	a_{Ri}	a_{Ii}	$W_I \alpha_{Ri} + W_R \alpha_{Ii}$
-1	-1	0	0	$-W_S$
-1	1	0	1	W_D
1	-1	1	0	$-W_D$
1	1	1	1	W_S

Where W_S and W_D were introduced in equation 2. From the table it is clear that $p = (a_{Ri} \oplus a_{Ii})$ can be used to select W_S or W_D . Using p , W_S and W_D , equation (10) and (11) can be written as

$$Z_R = \sum_{i=0}^{N-1} (-1)^{\overline{a_{Ii}}} [pW_S \vee \overline{p}W_D] 2^{-i-1} - W_D 2^{-N} =$$

$$\sum_{i=0}^{N-1} (\overline{a_{Ii}} \oplus [pW_S \vee \overline{p}W_D] + \overline{a_{Ii}}) 2^{-i-1} - W_D 2^{-N} \quad (12)$$

$$Z_I = \sum_{i=0}^{N-1} (-1)^{\overline{a_{Ri}}} [pW_D \vee \overline{p}W_S] 2^{-i-1} - W_S 2^{-N} =$$

$$\sum_{i=0}^{N-1} (\overline{a_{Ri}} \oplus [pW_D \vee \overline{p}W_S] + \overline{a_{Ri}}) 2^{-i-1} - W_S 2^{-N}. \quad (13)$$

When evaluating the sum, the powers $\overline{a_{Ri}}$ and $\overline{a_{Ii}}$ should be replaced with a_{Ri} and a_{Ii} for the case $i = 0$, since these bits represent the sign in two's complement representation. The partial inner product

$$\overline{a_{Ri}} \oplus [pW_D \vee \overline{p}W_S] + \overline{a_{Ri}} \quad (14)$$

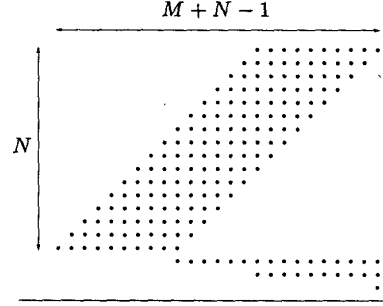

Figure 3: All partial product bits by significance for Z_R or Z_I . Input wordlength is N and coefficient wordlength is M .

is suitable for hardware mapping. It is realized as a multiplexer selecting $\pm W_S$ or $\pm W_D$, depending on the value of $p = (a_{Ri} \oplus a_{Ii})$. If $a_{Ri} \neq 0$ (or $a_{R0} = 1$), an inverted version of the coefficients is chosen, and a '1' in the least significant position is added, corresponding to a two's complement negation. The expression

$$\overline{a_{Ii}} \oplus [pW_S \vee \overline{p}W_D] + \overline{a_{Ii}} \quad (15)$$

is treated similarly. Figure 3 shows all the partial product bits that has to be added to generate Z_R or Z_I . The wordlength for the twiddle factor, W , is M bits and for the data, A , it is N bits, in this case 10 and 16 bits respectively. The top sixteen lines in the figure is the partial products generated inside the sum of equation (12) or (13), and the third line from bottom is the ones that form the corresponding two's complement of these products. The last two lines is the $-W_S|D 2^{-N}$ term.

5. Implementation

The proposed multiplier consists of two distributed arithmetic blocks, one calculating Z_R , and the other Z_I . The two blocks are similar and the difference is basically the sign in equation (1). Each block is divided into three parts, partial inner product generator, adder tree and carry lookahead adder, see figure 2.

The multiplier is synthesized to a 0.5μ cell library that does not contain any dedicated half or full adder cells. Estimated delay for a 10+10 by 16+16 multiplier using a worst case industrial environment is about 16 nanoseconds, compared to 34 nanoseconds for the array multiplier. About 55% of this delay is due to the adder tree. The partial inner-product generator takes 20% and the carry-lookahead adder uses 25% of the total delay. Most of the delay is spent in the adder tree, and by using dedicated adder cells

this delay could be decreased. However, the target cell-library does not contain any such cells and such improvements have not been made.

When designing the adder tree, a generic tree generator was used. This generator produces a tree with y inputs of wordlength x , that is a rectangle of x by y input bits. This rectangle has to be large enough to cover all the partial product bits of figure 3, i.e. $x = M + N - 1$ and $y = N + 3$. For certain sizes of N and M , the two last lines in figure 3 can be joined with two of the N first lines, minimizing y to $N + 1$. Unfortunately a lot of inputs to the adder tree are unused, and extra logic will be generated. Therefore, the area for the tree multiplier is about 75% larger than for the array multiplier. The number of gates for the array multiplier is 3000, while the tree multiplier uses 6200 gates, of which 4400 belongs to the two adder trees. Theoretically for a dedicated tree generator, the area should be only slightly larger than for the array multiplier. Both multipliers are currently under fabrication and the layout plots are shown in figure 4.

When data flows through the pipeline of the FFT processor, the wordlength has to increase to keep accuracy in the calculations. For the current application the input wordlength is 12+12 bits (real + imaginary) and the output wordlength is 16+16 bits. The twiddle-factors are kept constant at 10+10 bits at all stages of the pipeline. Different wordlengths in the datapath means that a set of multipliers of different wordlengths has to be instantiated if the longest wordlength is not to be used for all multipliers with a corresponding increase in area. Also, as FFT processors will be built for different applications the wordlength is subject to change. Therefore, the multiplier is fully parameterized and a multiplier of specific wordlength can be elaborated when needed.

For our application, the output wordlength should equal the input wordlength, that is, some of the least significant bits of the result are cut away. A simple rounding scheme is applied to lower the distortion when the output is truncated. A rounding bit is added to the right of the rightmost bit to be kept after truncation, causing a carry to propagate when the most significant position of the bits cut away is a one. A feature of the adder tree is that this bit can be inserted together with the partial inner products at the top of the tree, see figure 3. In the array multiplier, an additional row of half-adders had to be included to handle rounding. As rounding includes addition of a one with the product, arithmetic overflow at the output is possible. Therefore, a saturation unit is placed at the output of the carry-lookahead adder. This unit checks the most significant bits of

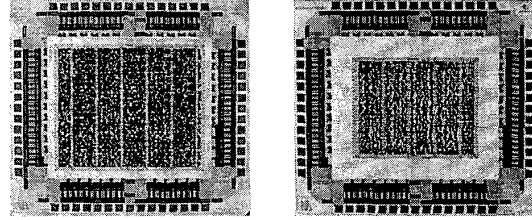

Figure 4: Plots of the two multipliers. Tree multiplier to the left and array multiplier to the right. The pad-frames are $3.2 \times 2.9 \text{ mm}^2$ and equal for both designs.

the result and modifies the output if an overflow has occurred.

5. Conclusion

A Wallace-tree based complex multiplier has been designed and simulated with a speed improvement of approximately 100% compared to a previously designed array multiplier. In a worst case industrial environment, the delay of a 10+10 by 16+16 multiplier is about 16 nanoseconds. This is when synthesized to a three metal-layer 0.5μ process with a standard cell library that does not contain any dedicated half- or full-adder cells. The figure is an estimation without post-layout delay information. Under equal conditions the complex array multiplier currently being used has a delay of 34 nanoseconds.

Since the multiplier together with an adder/subtractor is located in the critical path of the FFT-processor, throughput is expected to increase with approximately 80% while energy per operation is decreased. The multiplier is fully parameterized so any configuration of input and output wordlengths can be elaborated and synthesized. Both the array and the tree multiplier are currently under fabrication on the same die.

References

- [1] S. He and M. Torkelson. "A New Approach to Pipeline FFT Processor". In *Proc. of IEEE International Parallel Processing Symposium*, 1996.
- [2] S. He and M. Torkelson. "A Complex Array Multiplier Using Distributed Arithmetic". In *Proc. of IEEE Custom Integrated Circuits Conference*, 1991.
- [3] C.S. Wallace. "A Suggestion for a Fast Multiplier". *IEEE Transactions on Electronic Components*, Vol. EC-13, Feb 1964.
- [4] S.G. Smith and P.B. Denyer. "Efficient Bit-Serial Complex Multiplication and Sum-Of Products Computation Using Distributed Arithmetic". In *Proc. of IEEE ICASSP*, 1986.