



LUND UNIVERSITY

A 25-GHz Differential LC-VCO in 90-nm CMOS

Törmänen, Markus; Sjöland, Henrik

Published in:

Proc. 2008 IEEE Asia Pacific Conference on Circuits and Systems

2008

[Link to publication](#)

Citation for published version (APA):

Törmänen, M., & Sjöland, H. (2008). A 25-GHz Differential LC-VCO in 90-nm CMOS. In *Proc. 2008 IEEE Asia Pacific Conference on Circuits and Systems* (pp. 554-557)

Total number of authors:

2

General rights

Unless other specific re-use rights are stated the following general rights apply:

Copyright and moral rights for the publications made accessible in the public portal are retained by the authors and/or other copyright owners and it is a condition of accessing publications that users recognise and abide by the legal requirements associated with these rights.

- Users may download and print one copy of any publication from the public portal for the purpose of private study or research.
- You may not further distribute the material or use it for any profit-making activity or commercial gain
- You may freely distribute the URL identifying the publication in the public portal

Read more about Creative commons licenses: <https://creativecommons.org/licenses/>

Take down policy

If you believe that this document breaches copyright please contact us providing details, and we will remove access to the work immediately and investigate your claim.

LUND UNIVERSITY

PO Box 117
221 00 Lund
+46 46-222 00 00

A 25-GHz Differential LC-VCO in 90-nm CMOS

Markus Törmänen

Department of Electrical and Information Technology
Lund University, Box 118, 221 00 Lund Sweden
Email: Markus.Tormanen@eit.lth.se

Henrik Sjöland

Department of Electrical and Information Technology
Lund University, Box 118, 221 00 Lund Sweden
Email: Henrik.Sjoland@eit.lth.se

Abstract—A 25 GHz 90-nm CMOS differential voltage controlled oscillator is presented. Filtering is used at the common source node of the cross-coupled transistors to lower the phase noise. The frequency tuning is accomplished by a continuously tuned accumulation-mode MOS varactor. The oscillator measures a frequency tuning range of 8.7%, and a worst case phase noise over the tuning range of -106 dBc/Hz at 1 MHz offset, with a 1.1 V supply and a power consumption of 6.6 mW. The phase noise figure of merit, FOM, is between 185 dB and 187 dB over the tuning range.

I. INTRODUCTION

Local oscillator signals with low phase noise are needed in radio frequency (RF) transceivers, and the development of the complementary metal oxide semiconductor (CMOS) technology in the past decade has made it a viable technology for high frequency applications. The differential cross-coupled LC oscillator is well known for its good phase noise performance and ease of implementation [1]. This work presents measurement results of such an oscillator operating at 25 GHz, implemented in 90-nm CMOS, featuring a continuously tuned accumulation-mode varactor [2]. According to the measurements, the circuit is capable of generating low phase noise signals that could be used in e.g. a fully integrated 25 GHz CMOS wireless transceiver.

II. CIRCUIT DESIGN

The schematic of the voltage controlled oscillator (VCO) is shown in Fig. 1. It consists of two cross-coupled transistors that realize a negative resistance to compensate for the resonator losses, a source inductor, a FET current source, and a capacitor in parallel with the current source. The three latter components form a filtered current source [3], which improves the phase noise performance of the oscillator. The FET current source is used because the best phase noise performance is achieved when the amplitude in the resonance tank is on the limit of being current limited. The current source should ideally be noiseless, and have a high impedance at $2f_0$ to prevent the cross-coupled pairs triode resistance from loading the resonator in the switched state, i.e. when one transistor is off and the other one is in the triode region. A source inductor is therefore used to resonate the parasitics of the source node at $2f_0$. Also, a capaci-

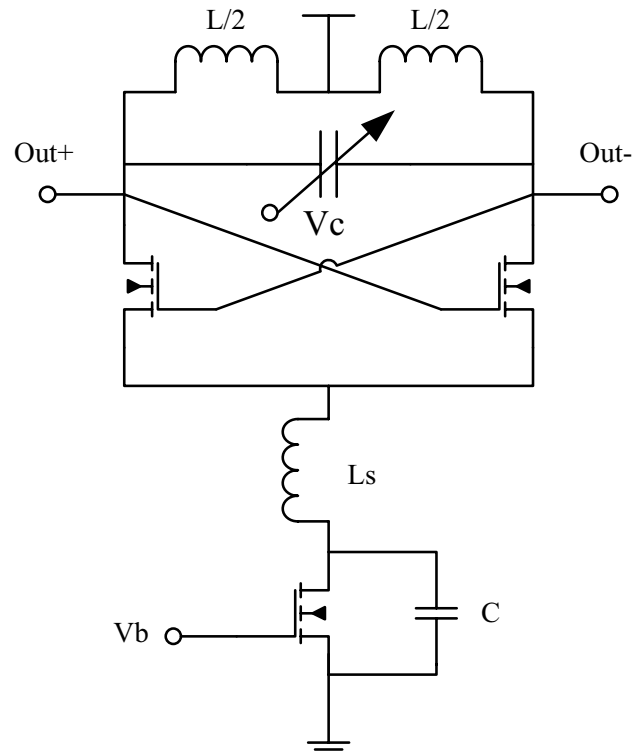

Fig. 1. VCO Schematic

tor in parallel with the current source shunts the high frequency noise from the current source to ground. The filtering technique thereby prevents tail current noise at $2f_0$ from creating phase noise, but low frequency tail current noise will still cause amplitude noise, which can be converted to phase noise by the nonlinearities of the varactor [4].

A major challenge in oscillator design is to simultaneously achieve a low phase noise and a wide frequency tuning range. In oscillators using continuous frequency tuning, a wide tuning range is obtained using a large varactor with a high C_{max}/C_{min} ratio. Unfortunately the losses of such a varactor will degrade the quality factor of the resonator, resulting in increased phase noise.

TABLE I
SIMULATED INDUCTOR DATA

| Inductor | Turns | Inductance (pH) | Q | fs (GHz) |
|-------------|-------|-----------------|----|----------|
| L @ f_0 | 2 | 315 | 26 | 82 |
| Ls @ $2f_0$ | 1 | 90 | 18 | 157 |

An accumulation-mode varactor [2], [5] was used in this work since it offers low losses. It operates in the accumulation and depletion regions, and has a non-minimum channel length, L , of 110 nm. A compromise was made not to use minimum channel length (90 nm), since although it would have given the varactor a slightly larger quality factor, Q , it would also have resulted in a smaller tuning range. It can be shown that the Q of the varactor is proportional to L^{-2} in the accumulation region [6], and to L^{-1} in the depletion region [7]. Since the losses of the varactor are dominated by series resistance, Q is inversely proportional to frequency, and the varactor will limit the total Q of the resonator at high frequencies and tuning ranges. There are no extra process steps used in the fabrication of the accumulation-mode varactor, but its generally not supported by the foundries. An inversion-mode varactor was used during the simulation phase, since no model of a high frequency accumulation-mode varactor with short channel length was available.

The inductor geometries were found by using FastHenry in combination with the in-house inductor optimization tool, Indentro [8]. The tank inductor was realized as a two turn differential inductor, and the source node inductor as a single turn spiral. The simulated inductor data is shown in Table I. The capacitively coupled substrate losses are blocked by patterned ground shields in metal 1 used beneath the inductors.

To enable measurements the oscillator was connected to open drain buffers designed to drive 50Ω loads, Fig. 2, which were implemented on the same chip.

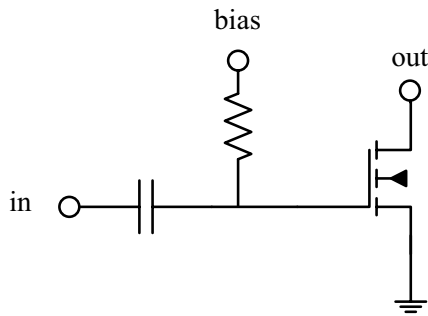

Fig. 2. Open drain buffer

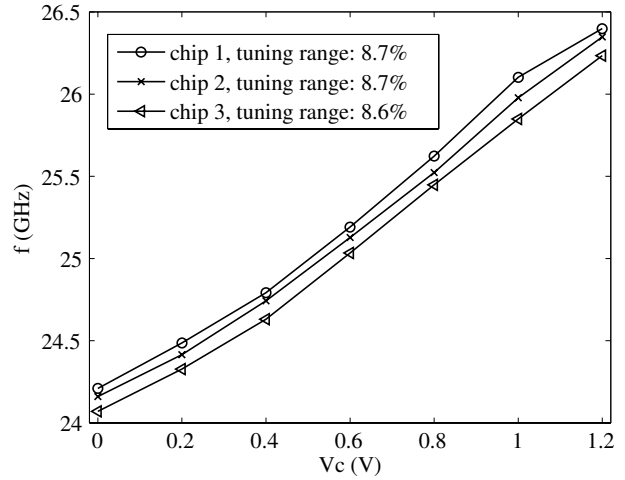

Fig. 3. Frequency vs. control voltage

III. LAYOUT

The die photo of the oscillator is shown in Fig. 8, where the padframe area measures $600 \mu\text{m} \times 600 \mu\text{m}$. The core area of the VCO measures just $120 \mu\text{m} \times 310 \mu\text{m}$, and is dominated by the two inductors. The entire layout was designed as symmetric as possible to minimize amplitude and phase errors. The pads on the top side are the RF-output signals (G-S-G-S-G) from the open-drain buffers. The pads on the bottom side are used for supply and bias voltages. The parasitic inductances of the wires to the inductors have been taken into account by adjusting the value of the tank inductor, L , and the source inductor, L_s , respectively. Also, all pads, except for the two RF outputs, are ESD protected. The ESD protection is realized using pn diodes for the pads, and multiple distributed clamps between the supply voltage and ground.

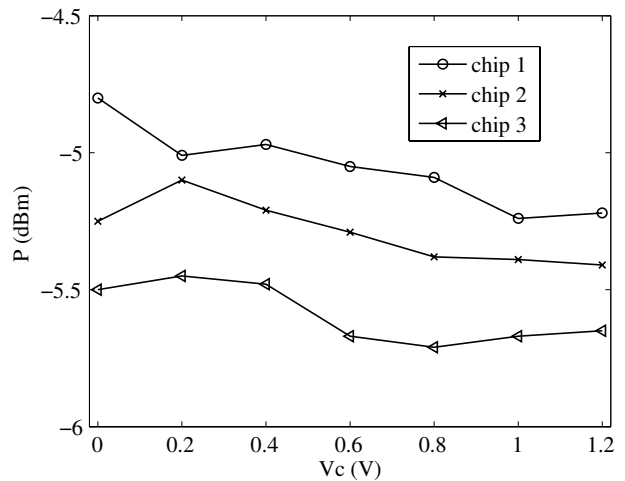

Fig. 4. Output power vs. control voltage

TABLE II
PERFORMANCE OF SOME PREVIOUSLY REPORTED CMOS VCOS AND THIS WORK

| Ref. | Process | f_0 (GHz) | Tuning (%) | P_{DC} (mW) | PN @ 1 MHz (dBc/Hz) | FOM (dB) | FOM_T (dB) |
|-----------|-------------------|-------------|------------|---------------|---------------------|----------|--------------|
| This work | 90nm CMOS | 25.3 | 8.7 | 6.6 | -105.8* | 185 | 184 |
| [9] | 90nm CMOS | 18 | 8.3 | 4.2 | -116* | 195 | 194 |
| [10] | 0.13 μ m CMOS | 18 | 5.6 | 17.3 | -117 | 190 | 185 |
| [11] | 0.13 μ m CMOS | 11.55 | 5.5 | 8.1 | -110.8 | 183 | 178 |
| [12] | 0.18 μ m CMOS | 16 | 5.6 | 8.1 | -111 | 186 | 181 |

*worst case phase noise over the tuning range

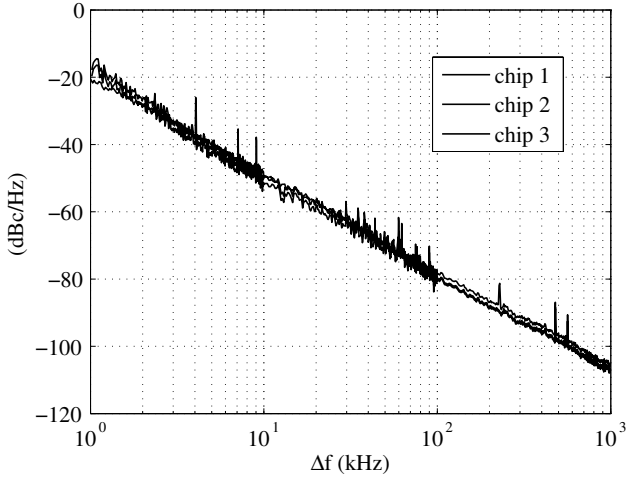

Fig. 5. Phase Noise vs. offset frequency, $V_c=0.6$ V

IV. EXPERIMENTAL RESULTS

Three different samples of the oscillator have been measured. The measurements were performed with a probe station using on-wafer probing with Infinity RF and Quadrant DC probes from Cascade Microtech. The best performance of the oscillator was found at 1.1 V supply and 6 mA current. This gives a power consumption of 6.6 mW for the oscillator core. The open-drain buffers were biased to a drain voltage of 1 V and a drain current of 6.5 mA per buffer. The following results were measured at this bias point.

A spectrum analyzer, Rhode & Schwarz FSU50, was used to measure the frequency tuning characteristic and the buffer output power. The results for the three different samples are shown in Fig. 3 and Fig. 4. As can be seen the tuning range measures 8.7%.

The phase noise of the three chips was measured using a Europtest PN9000 phase noise measurement system together with an external downconversion mixer, Marki M90765. A signal generator, Agilent E8257D, was used to generate the LO signal for the mixer.

The phase noise was measured versus offset frequency (Δf) for a varactor control voltage (V_c) of 0.6 V, see Fig. 5. The phase noise was also measured versus the var-

actor control voltage, Fig. 6. As can be seen in the figure, there is a phase noise variation of about 3 dB over the tuning range. Also shown in the legend of Fig. 6 is the phase noise figure of merit, FOM, which is between 185 dB and 188 dB for the measured samples, calculated at 1 MHz offset frequency using

$$FOM = 10 \log_{10} \left(\left(\frac{f_0}{\Delta f} \right)^2 \cdot \frac{1}{10^{\frac{L(\Delta f)}{10}} P} \right) \quad (1)$$

,where P is the power consumption of the oscillator in mW, f_0 the oscillation frequency, Δf the offset frequency, and $L(\Delta f)$ the phase noise at Δf . To take also the tuning range into account, the expression (1) can be modified [13] to

$$FOM_T = 10 \log_{10} \left(\left(\frac{f_0 \cdot \text{tuning}(\%)}{10 \cdot \Delta f} \right)^2 \cdot \frac{1}{10^{\frac{L(\Delta f)}{10}} P} \right) \quad (2)$$

,which is between 184 dB and 187 dB for the measured samples at 1 MHz offset.

A performance comparison of some published state-of-the-art CMOS VCOS above 11 GHz and this work is shown in Table II. Some of the references in the table report only the best case value for the phase noise figure of merit, but to avoid sweet spots it is the worst case value over the tuning range that should be used for comparison. As can be seen in Table II the oscillator presented in this work compares well both in FOM and FOM_T . However, excellent performance is reported by Jacobsson et. al. [9], using post-processed high-Q inductors. This work instead uses standard CMOS without post processing or extra thick top metal options.

The oscillator pushing has also been measured and is shown in Fig. 7. As can be seen in the figure, there is approximately a 270 MHz frequency increase for a supply voltage change from 1.2 V to 0.9 V.

V. CONCLUSION

A differential 25 GHz LC VCO using an accumulation-mode varactor has been implemented in a 90-nm CMOS process. The oscillator measures a frequency tuning range of 8.7%. A good phase noise performance is measured over the entire tuning range, at worst -106 dBc/Hz at 1 MHz offset, with a power consumption of 6.6 mW for the oscillator core. This gives a phase noise figure of merit, FOM, of

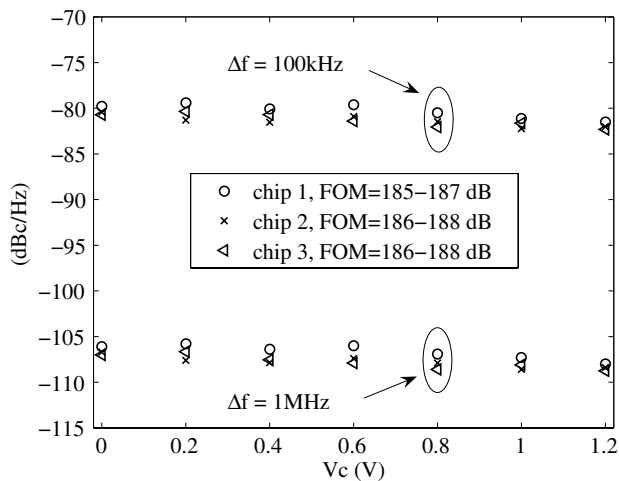

Fig. 6. Phase noise vs. control voltage

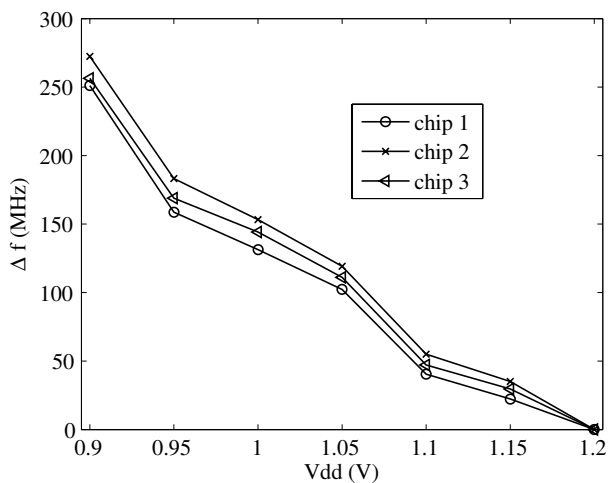

Fig. 7. Oscillator frequency pushing, $V_c=0.6$ V

185 dB. Taking also the tuning range into account gives a figure of merit, FOM_T , of 184 dB.

VI. ACKNOWLEDGMENT

The authors would like to thank UMC (United Microelectronics Corporation) for access to the state-of-the-art CMOS technology. They would also like to thank the Knut and Alice Wallenberg foundation for financial support in building up the high frequency measurement laboratory.

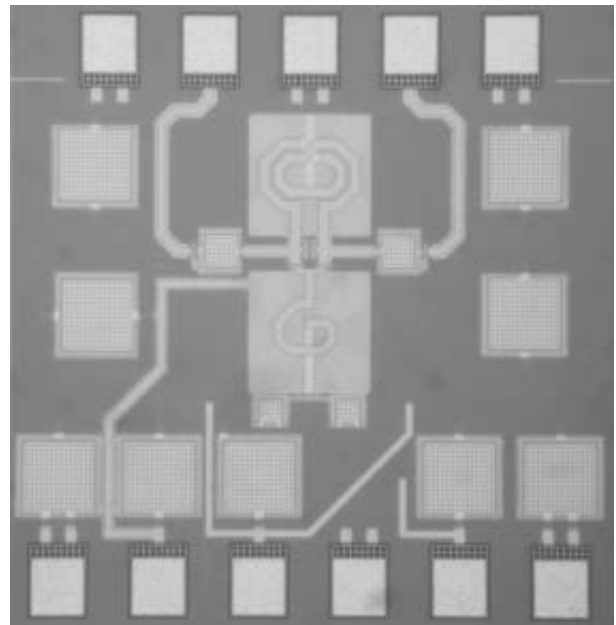

Fig. 8. Die photograph of the VCO ($600 \mu\text{m} \times 600 \mu\text{m}$).

REFERENCES

- [1] A. Hajimiri and T. H. Lee, "Design Issues in CMOS Differential LC Oscillators," *IEEE JSSC*, vol. 34, no. 5, pp. 717–724, May 1999.
- [2] P. Andreani and S. Mattisson, "On the Use of MOS Varactors in RF VCO's," *IEEE JSSC*, vol. 35, no. 6, pp. 905–910, June 2000.
- [3] E. Hegazi, H. Sjöland, and A. Abidi, "A Filtering Technique to Lower LC Oscillator Phase Noise," *IEEE JSSC*, vol. 36, no. 12, pp. 1921–1930, Dec. 2001.
- [4] C. Samori, A. L. Lacaita, A. Zanchi, S. Levantino, and F. Torrisi, "Impact of indirect stability on phase noise performance of fully-integrated LC tuned VCOs," in *Proc. ESSCIRC*, Sep. 1999, pp. 202–205.
- [5] R. Castello, P. Erratico, S. Manzini, and F. Svelto, "A $\pm 30\%$ Tuning Range Varactor Compatible with future Scaled Technologies," in *Symp. VLSI Circuit Dig. Tech. Papers*, June 1998, pp. 34–35.
- [6] T. Soorapanth, C. P. Yue, D. K. Shaeffer, T. H. Lee, and S. S. Wong, "Analysis and Optimization of Accumulation-Mode Varactor for RF ICs," in *Symp. VLSI Circuit Dig. Tech. Papers*, June 1998, pp. 32–33.
- [7] F. Svelto, P. Erratico, S. Manzini, and R. Castello, "A Metal-Oxide-Semiconductor Varactor," *IEEE Electron Device Letters*, vol. 20, pp. 164–166, Apr. 1999.
- [8] N. Troedsson, <http://www.indentro.com>, 2008.
- [9] H. Jacobsson, M. Bao, L. Aspemyr, A. Mercha, and G. Carcho, "Low Phase Noise sub-1 V Supply 12 and 18 GHz VCOs in 90-nm CMOS," in *Proc. IEEE MIT-S*, June 2006, pp. 573–576.
- [10] G. Le Grand de Mercey, "A 18GHz Rotary Traveling Wave VCO in CMOS with I/Q outputs," in *Proc. ESSCIRC*, Sep. 2003, pp. 489–492.
- [11] B. Park, S. Lee, S. Choi, and S. Hong, "A 12-GHz Fully Integrated Cascade CMOS LC VCO With Q-Enhancement Circuit," *IEEE Microwave and Wireless Components Letters*, vol. 18, no. 2, pp. 133–135, Feb. 2008.
- [12] C. L. Yang and Y. C. Chiang, "Low Phase-Noise and Low-Power CMOS VCO Constructed in Current-Reused Configuration," *IEEE Microwave and Wireless Components Letters*, vol. 18, no. 2, pp. 136–138, Feb. 2008.
- [13] J. Kim *et al.*, "A Power-Optimized Widely-Tunable 5-GHz Monolithic VCO in a Digital SOI CMOS Technology on High Resistivity Substrate," in *Proc. ISLPED*, Aug. 2003, pp. 434–439.