



LUND UNIVERSITY

Production of poly(3-hydroxybutyrate) and ectoines using a halophilic bacterium

Doan Van, Thuoc

2009

[Link to publication](#)

Citation for published version (APA):

Doan Van, T. (2009). *Production of poly(3-hydroxybutyrate) and ectoines using a halophilic bacterium*. [Doctoral Thesis (compilation), Biotechnology].

Total number of authors:

1

General rights

Unless other specific re-use rights are stated the following general rights apply:

Copyright and moral rights for the publications made accessible in the public portal are retained by the authors and/or other copyright owners and it is a condition of accessing publications that users recognise and abide by the legal requirements associated with these rights.

- Users may download and print one copy of any publication from the public portal for the purpose of private study or research.
- You may not further distribute the material or use it for any profit-making activity or commercial gain
- You may freely distribute the URL identifying the publication in the public portal

Read more about Creative commons licenses: <https://creativecommons.org/licenses/>

Take down policy

If you believe that this document breaches copyright please contact us providing details, and we will remove access to the work immediately and investigate your claim.

LUND UNIVERSITY

PO Box 117
221 00 Lund
+46 46-222 00 00

Production of poly(3-hydroxybutyrate) and ectoines using a halophilic bacterium

Thuoc Doan Van
(Đoàn Văn Thuộc)



LUND
UNIVERSITY

Department of Biotechnology
Doctoral Thesis
December 2009

Academic thesis which, by due permission of the Faculty of Engineering of Lund University will be publicly defended on Thursday December 10, 2009 at 10:30 a.m. in Lecture Hall B, at the Center for Chemistry and Chemical Engineering, Sölvegatan 39, Lund, for the degree of Doctor of Philosophy in Engineering.

Faculty opponent is Dr. T. Ramachandriah Shamala, Department of Food Microbiology, Central Food Technological Research Institute, Mysore, India

© 2009 **Thuoc Doan Van**
(Đoàn Văn Thược)

Doctoral thesis
December 2009

Department of Biotechnology
Center for Chemistry and Chemical Engineering
Lund University
P.O.Box 124
SE-221 00
Sweden

ISBN 978-91-89627-64-2
ISRN LUTKDH/TKBT—09/1118—SE
Printed by Media-Tryck, Lund University, Sweden, 2009

Abstract

Halomonas boliviensis is a moderate halophilic bacterium, isolated from a soil sample around a hypersaline lake Laguna Colorada in the Andean region of Bolivia. The organism is capable of growing over a wide range of NaCl concentration (0-25 %, w/v), however with an optimum of about 4.5 % (w/v) NaCl. It is able to accumulate two useful products: poly(3-hydroxybutyrate) (PHB) and ectoines (ectoine and hydroxyectoine).

H. boliviensis can accumulate PHB from several different carbon sources, e.g., glucose, xylose, sucrose, maltooligosaccharides, sodium acetate and butyric acid, as well as from cheap substrate sources such as wheat bran hydrolysate and digested potato waste. A PHB content of 50-90 % of cell dry weight (wt%) can be reached depending on the carbon source and cultivation conditions used. Under nitrogen limitation, a maximum PHB content of 81 wt%, cell dry weight (CDW) of 44 g/L, and PHB volumetric productivity of 1.1 g/L/h were obtained in fed-batch culture with glucose as the carbon source. The PHB content reached by *H. boliviensis* was comparable to that of some of the known high-PHA producers.

The organism accumulates ectoines in response to high salt concentrations in the surrounding medium. Ectoine has been detected at and above sodium chloride concentration of 5 % (w/v) while the presence of hydroxyectoine was observed from 10 % (w/v) NaCl. The content of the ectoines increased on raising the salt concentration. In order to improve the ectoine productivity, a mathematical method was applied with the aim of determining optimal conditions for ectoine production. The optimized conditions were then used for a two-step fed-batch culture, and it was found that the ectoine concentration and productivity were significantly increased, reaching maximum values of 9.2 g/L and 6.3 g/L/d, respectively. A two-step fed-batch culture was also applied for the co-production of ectoine and hydroxyectoine. By increasing the NaCl concentration to 18.5% (w/v) in the second step, the content of ectoines was augmented to a maximum level of about 27.8 wt% with the relative proportion of hydroxyectoine at 57 %. The productivity of ectoines was also raised to 10 g/L/d, which is among the highest reported so far.

Co-production of ectoine and PHB could be achieved by *H. boliviensis* in a two-step fed-batch culture. *H. boliviensis* was first grown under optimal conditions in order to achieve a high cell mass. The bacterial cells were then grown in a second fed-batch system at higher salt concentration and under nitrogen limitation for inducing ectoine and PHB accumulations. This process resulted in an ectoine content of 6.1 wt% and a productivity of 2.8 g/L/d, as well as a maximum PHB content of 68.5 wt% and a productivity of 1.06 g/L/h after an overall production

time of 40 h. The PHB productivity was similar to that found during the production of PHB alone by *H. boliviensis*.

The present study has demonstrated the protective effect of ectoine and hydroxyectoine on enzymes with respect to pH stress. A xylanase from *Bacillus halodurans* retained a significantly higher activity in the presence of ectoine and hydroxyectoine, during incubation at low pH (4.5) as well as at high pH (11, 12). It is suggested that the presence of ectoines results in reduced conformational flexibility of the biomolecules.

List of Papers

This thesis is based on the following papers, referred to in the text by their Roman numerals. The papers are attached as appendices at the end of the thesis.

I. Utilization of agricultural residues for poly(3-hydroxybutyrate) production

by *Halomonas boliviensis* LC1. Van-Thuoc D, Quillaguamán J, Mamo G, Mattiasson B. *Journal of Applied Microbiology* 2008, 104, p. 420-428

II. Poly(3-hydroxybutyrate) production by *Halomonas boliviensis* in fed-batch culture.

Quillaguamán J, Van-Thuoc D, Guzmán H, Guzmán D, Martín J, Everest A, Hatti-Kaul R. *Applied Microbiology and Biotechnology* 2008, 78, p. 227-232

III. A process for the production of ectoine and poly(3-hydroxybutyrate) by

Halomonas boliviensis. Guzmán H, Van-Thuoc D, Martín J, Hatti-Kaul R, Quillaguamán J. *Applied Microbiology and Biotechnology* 2009, 84, p. 1069-1077

IV. Ectoine production by *Halomonas boliviensis*: optimization using response surface methodology.

Van-Thuoc D, Guzmán H, Thi-Hang M, Hatti-Kaul R. *Marine Biotechnology* (Accepted for publication).

V. High productivity of ectoines by *Halomonas boliviensis* using a combined

two-step fed-batch culture and milking process. Van-Thuoc D, Guzmán H, Quillaguamán J, Hatti-Kaul R. Manuscript, 2009

VI. Enzyme stabilization by ectoine and hydroxyectoine at high pH.

Van-Thuoc D, Hashim S, Hatti-Kaul R, Mamo G. Manuscript, 2009.

Not included in this thesis (mini-review):

Synthesis and production of polyhydroxyalkanoates by halophiles: current potential and future prospects. Quillaguamán J, Guzmán H, Van-Thuoc D, Hatti-Kaul R. *Applied Microbiology and Biotechnology* (Accepted for publication).

My contribution to the papers

All the work described in this thesis was performed under the supervision of Professor Rajni Hatti-Kaul together with Professor Bo Mattiasson and Dr. Jorge Quillaguamán.

Paper I: I performed all the experimental work, I wrote the paper together with Jorge Quillaguamán.

Paper II: I performed certain parts of the experimental work and I assisted in the writing of the paper.

Paper III. I performed certain parts of the experimental work and I wrote the related parts of the paper.

Paper IV. I performed all the experimental work and I wrote the paper with some help from Hector Guzmán and Mai Thi-Hang.

Paper V. I performed approximately half of the experimental work and I wrote the paper together with Jorge Quillaguamán and Hector Guzmán.

Paper VI. I performed the main parts of the experimental work, and I wrote the paper together with Gashaw Mamo and Suhaila Hashim.

Abbreviations

ABC transporter	ATP binding cassette transporter
AsD	Aspartate semialdehyde dehydrogenase
AsK	Aspartate kinase
AsT	Aspartate transaminase
CDW	Cell dry weight
DA	Diaminobutyric acid
EctA	Diaminobutyric acid acetyltransferase
EctB	Diaminobutyric acid transaminase
EctC	Ectoine synthase
EctD	Ectoine hydroxylase
LDH	Lactate dehydrogenase
mcl	Medium-chain-length
MS channel	Mechanosensitive channel
MSG	Monosodium glutamate
NADA	N γ -acetyl -L-2,4-diaminobutyric acid
PFK	Phosphofructokinase
PHA	Polyhydroxyalkanoate
PhaC	PHA synthase
PhaP	Phasin protein
PhaR	PHA regulatory protein
PhaZ	PHA depolymerase
PHB	Poly(3-hydroxybutyrate)
<i>phbA</i>	β -ketoacyl-CoA thiolase gene
<i>phbB</i>	acetoacetyl-CoA reductase gene
<i>phbC</i>	PHB polymerase gene
P(3HB-co-3HA)	Poly(3-hydroxybutyrate-co-3-hydroxyalkanoate)
P(3HB-co-3HHx)	Poly(3-hydroxybutyrate-co-3-hydroxyhexanoate)
P(3HB-co-3HV)	Poly(3-hydroxybutyrate-co-3-hydroxyvalerate)
P(3HB-co-3HV-co-4HB)	Poly(3-hydroxybutyrate-co-3-hydroxyvalerate-co-4-hydroxybutyrate)
P(3HB-co-4HB)	Poly(3-hydroxybutyrate-co-4-hydroxybutyrate)
P(3HHx-co-3HO)	Poly(3-hydroxyhexanoate-co-3-hydroxyoctanoate)
P(3HV)	Poly(3-hydroxyvalerate)
P(4HB)	Poly(4-hydroxybutyrate)
P(4HV)	Poly(4-hydroxyvalerate)
PLA	Poly(lactic acid)
scl	Short-chain-length
TeaABC	Transporter for ectoine accumulation
wt%	Percent of cell dry weight

Contents

1. Introduction.....	1
1.1. Scope of the thesis.....	2
2. Halophilic microorganisms: diversity and applications.....	3
2.1. Hypersaline environments.....	3
2.2. Adaptation of microorganisms to saline environments.....	4
2.3. Diversity of halophiles.....	7
2.3.1. Halophilic <i>Archaea</i>	7
2.3.2. Halophilic <i>Bacteria</i>	8
A moderate halophilic bacterium <i>Halomonas boliviensis</i> LC1 ...	10
2.3.3. Halophilic <i>Eucarya</i>	10
3. Biopolyesters: synthesis, properties, and applications.....	13
3.1. Polyhydroxyalkanoates.....	13
3.2. Polyhydroxyalkanoates in halophiles.....	16
3.2.1. PHA accumulation in halophilic <i>Archaea</i>	16
3.2.2. PHA accumulation in halophilic bacteria of the family <i>Halomonadaceae</i>	16
3.3. PHA biosynthesis.....	18
3.4. Properties and applications of PHA.....	21
4. Compatible solutes and their applications.....	23
4.1. Uptake of compatible solutes in bacteria.....	25
4.2. Synthesis of compatible solutes (ectoines).....	26
4.3. Release of compatible solutes.....	27
4.4. Applications of ectoines.....	28
5. Biotechnological production of polyhydroxyalkanoates and ectoines...	31
5.1. Cell cultivation technologies.....	31
5.1.1. Fed-batch cultivation.....	31
5.1.2. Fed-batch cultivation with medium exchange.....	32
5.1.3. Continuous cultivation.....	32
5.2. Genetic technologies to facilitate production.....	32
5.2.1. Genetic engineering.....	32
5.2.2. Metabolic engineering.....	33
5.3. Polyhydroxyalkanoate production.....	34
5.3.1. PHA production by wild type strains.....	34
5.3.2. PHA production by <i>Halomonas boliviensis</i>	37

5.3.3. PHA production using recombinant <i>E. coli</i>	38
5.4. Ectoines production.....	39
5.4.1. Ectoines production by <i>H. boliviensis</i>	41
5.5. Co-production of PHA and ectoines.....	42
6. Concluding remarks and future perspectives.....	45
Acknowledgements.....	47
References.....	49

1. Introduction

Industrial biotechnology is gaining in importance with an increasing interest in sustainable means of production and in shifting the raw material base from fossil to renewable resources as well as from non-biodegradable to biodegradable products. Industrial biotechnology involves the use of microorganisms and their enzymes for the production of energy, chemicals and materials. The natural microbial diversity is enormous and it is claimed that only a small fraction of the total microbial population has been isolated and characterized. Various environments with extreme conditions, such as high/low temperature, high/low pH, high salinity and high pressure, provide unique microorganisms with great potential for applications in food, chemicals, pharmaceuticals and environmental sectors.

The microorganisms inhabiting saline environments – halophiles - can be envisioned to possess a number of interesting applications in biotechnology. Some of these are unique and found nowhere else in the living world, while others can be found in non-halophiles. Nevertheless, halophiles present certain advantages for the development of biotechnological production processes (Oren 2002b). Polyhydroxyalkanoates (PHAs) and compatible solutes are two products that can be found in both halophiles and non-halophiles.

PHAs are a group of biodegradable polymers of biological origin. They are attractive substitutes for conventional petrochemical plastics as a result of having material properties similar to various thermoplastics and elastomers, as well as being completely biodegradable upon disposal under specific environmental conditions (Sudesh et al. 2000). PHAs are currently industrially produced by recombinant *Escherichia coli* strains (Philip et al. 2007). Nevertheless, the production cost of PHA is high as compared to that of the non-biodegradable plastics of fossil origin. A great deal of effort has been devoted to reducing the production cost by developing more efficient bacterial strains and fermentation/recovery processes, and utilizing cheap carbon sources (Choi and Lee 1999).

Compatible solutes or osmolytes are low molecular weight organic compounds that accumulate to a high concentration inside the cells. Osmolytes are polar, highly soluble molecules, most of which are either uncharged or

zwitterionic at physiological pH. The osmolytes help to maintain the turgor pressure, cell volume, and concentration of electrolytes in the cells. Ectoines (ectoine and its hydroxyl derivative, hydroxyectoine) are well known as the most abundant compatible solutes, accumulated intracellularly by many halotolerant and halophilic bacteria for osmotic stress protection (Roberts 2005). In addition to their role as osmotic balancing agents, ectoines have gained much attention in biotechnology as protective agents for enzymes, DNA, membranes and even entire cells against stress conditions (Welsh 2000).

Halomonas boliviensis is a moderately halophilic bacterium, isolated from hypersaline lakes in the Bolivian Andean region. The organism displays an optimum growth at 4.5 % (w/v) of NaCl and can accumulate poly(3-hydroxybutyrate) (PHB) when grown on various renewable carbon sources (Quillaguamán et al 2005; 2006). PHB is the most widespread and best-characterized member of the PHAs, with material properties similar to those of polypropylene. It has moreover been used in the fabrication of various products such as coated paper, compost bags, films, bottles. *H. boliviensis* can also accumulate ectoines (ectoine and hydroxyectoine) and the extent of accumulation depends on the salt concentration in the surrounding medium. Only ectoine has been detected at lower salt concentrations (5-7.5 % NaCl), and has been found to increase in concentration with higher salt concentrations. At an elevated salt concentration range (i.e., 10-18 %, w/v), the presence of hydroxyectoine has also been detected.

1.1. Scope of the thesis

The work presented in this thesis has been focused on the production of PHB and ectoines by *Halomonas boliviensis*.

The production cost is one of the most important factors limiting the application of PHB, and three different strategies were thus investigated to reduce the polymer production cost: the use of cheap substrates such as wheat bran hydrolysate and digested potato waste (**Paper I**), the design of a defined medium and the development of a cultivation strategy in order to achieve a high PHB volumetric productivity (**Paper II**), and the design of a process for the co-production of PHB and ectoine (**Paper III**)

In the second part of the study, a process for the production of ectoines was developed by optimizing the medium components using a mathematical method combined with medium exchange (two-step fed-batch cultivation) (**Paper IV**), and two-step fed-batch cultivation combined with “bacterial milking” (**Paper V**). The ability of ectoines (ectoine and hydroxyectoine) as protective agents for an enzyme – xylanase – against pH stress was also investigated (**Paper VI**).

2. Halophilic microorganisms: diversity and applications

Microbial life can be found over an extremely wide range of salt concentrations; from that of fresh water (containing less than 0.5 g dissolved salt per liter), through sea water (around 35 g dissolved salts per liter) to hypersaline environments with salt concentrations exceeding 350 g/L (Oren 1999). The diversity in the properties of saline and hypersaline habitats on Earth is reflected in the great diversity within the microbial communities adapted to life under the prevailing conditions (Oren 2002a; 2002b; 2006).

2.1. Hypersaline environments

Hypersaline waters are those containing salt concentrations notably higher than those of seawater (Rodriguez-Valera 1993). The properties of hypersaline environments are primarily defined according to the total salt concentration and the ionic composition. Many hypersaline environments have originated by evaporation of seawater, encouraged by a restricted flow, high temperature, low rainfall, low humidity and high wind speed. Such aquatic environments are referred to as thalassohaline (from the Greek *thalasso*, the sea) (McGenity et al. 2000; Oren 2002a; 2006; Rodriguez-Valera 1993). Their salt composition is similar to that of seawater: sodium and chloride are the dominating ions, and the pH is near neutral or slightly alkaline (Oren 2002a; 2006). The Great Salt Lake is an example of a thalassohaline environment.

In other hypersaline environments, the ionic composition may greatly differ from that of seawater. Many of these environments lack certain of the components found in seawater salt, or contain other predominant ions. These are called athalassohaline environments (Rodriguez-Valera 1993; Oren 2002a; 2006). An example is the Dead Sea; a lake in which divalent cations dominate, with concentration of Mg^{2+} (around 1.9 M) and Ca^{2+} (around 0.45 M) exceeding those of Na^+ (around 1.6 M) and K^+ (around 0.2 M). As a result of the high Ca^{2+} concentration, the solubility of sulfate is low and monovalent anions such as Cl^- and Br^- dominate (> 99.9 % of the total anion). The pH of the Dead Sea brine is around 5.8-6.0 (Oren 2002a; 2006).

Alkaline athalassohaline brines are the most abundant. Alkaline soda lakes are present in diverse geographic locations such as Lake Magadi (Kenya) (Eugster 1980), and other lakes in the East African Rift Valley (Grant and Tindall 1986; Grant et al. 1990), the shallow lakes of the Wadi Natrun (Egypt) (Imhoff et al. 1979), soda lakes in China (Wang and Tang 1989; Xu et al. 1999; Zheng et al. 1993) and India (Jakher et al. 1990; Upasani and Desai 1990), as well as Mono Lake, California, and Big Soda Lake, Nevada, USA (Oren 2002b). Na^+ , Cl^- , HCO_3^- , and CO_3^{2-} are the major ions in the brines. The pH of such brines may reach 10-11 or even higher (Grant and Tindall 1986). Because of the high pH, the solubility of the divalent cations Mg^{2+} and Ca^{2+} is very low, and the concentrations of these ions may be below the detection limit (Oren 2006).

The Bolivian Andean region of Bolivia, the Altiplano – 200 000 km² closed basin, is located at an altitude of 4000-4500 m above sea level. There are a large number of isolated brines and saline lakes at the southern end of Altiplano formed as a result of evaporation exceeding the rainfall (Risacher 1992). A halophilic microorganism from one hypersaline lake from that region, Laguna Colorada (Spanish for red colored lake), located at an altitude of 4278 m above the sea level, was used for the work done in this thesis. The lake's name comes from the bright red coloration, which is caused by dense population of algae such as *Dunaliella salina* and several bacterial strains with pink, orange and red pigments (Hurlbert and Chang 1984; Quillaguamán et al. 2004; Servant-Vildary and Roux 1990; Sylvestre et al. 2000). According to earlier reports (Hurlbert and Chang 1984), large ice islands reaching up to 7 m above water surface characterized this lake. The salinity in water varies between 6-12 % NaCl, pH is about 8.5, and the water temperature is around 0 °C in midwinter and around 15 °C in midsummer.

Based on their salt tolerance/requirement, microorganisms can be divided into two main groups: those capable of growing in the presence and absence of salt, denoted halotolerant microorganisms (optimum growth below 0.2 M NaCl), and those for which the presence of salt is essential, referred to as halophiles (Kushner, 1978). Four categories of halophiles can be recognized: slight halophiles (many marine microorganisms, optimum growth between 0.2 and 0.5 M NaCl), moderate halophiles (optimum growth between 0.5 and 2.0 M NaCl), borderline extreme halophiles (optimum growth between 2.0 and 3.0 M NaCl), and extreme halophiles (optimum growth between 3.0 and 5.0 M NaCl) (Gilmour 1990; Grant et al. 1998).

2.2. Adaptation of microorganisms to saline environments

Microorganisms that live at high salt concentrations are exposed to media of low water activity, and must have mechanisms to avoid water loss by osmosis. Since

water is freely permeable across the cytoplasmic membrane, osmotic adaptation demands a cytoplasm of similar osmotic potential to the surrounding environment (Grant et al. 1998). There are two basic strategies within the microbial world which enable microorganisms to cope with the osmotic stress inherent to the presence of high salt concentrations: (i) the “salt-in” strategy in which the microorganisms may maintain high intracellular salt concentrations, at least osmotically equivalent to the external concentration. In this case, all intracellular systems should be adapted to the presence of the high salt concentration, and (ii) the “compatible solute” strategy or the low “salt in” strategy in which the microorganisms may maintain low salt concentrations within their cytoplasm. The osmotic pressure of the medium is then balanced by organic osmolytes, also called compatible solutes. In this case, no special adaptation of the intracellular systems is required (Oren 2002a; 2002b; 2006; 2008).

Only a few groups of halophiles use salt (mainly KCl) to provide the osmotic balance with the outside medium. These include the aerobic *Archaea* of the *Halobacteriaceae* family, the anaerobic *Bacteria* of the order *Haloanaerobiales*, and the recently discovered red, extremely halophilic, aerobic bacterial genus *Salinibacter* (Oren 2008). Potassium is the main intracellular cation in all cases, and chloride is used as the dominant intracellular anion (Gochbauer and Kushner 1971; Pérez-Fillol and Rodríguez-Vela 1986; Oren et al. 1997; Oren et al. 2002).

The presence of high intracellular salt concentrations thus requires a special adaptation of the proteins and other macromolecules of the cells in order for it to function in the presence of large amounts of salt. However, these adaptations render the cells significantly dependent on the continuous presence of high salt concentrations for maintaining their structural integrity and viability. Most of the enzymes and other proteins of *Halobacteriales* become denatured when suspended in solutions containing less than 1-2 M salt. Several enzymes are more active in the presence of KCl than NaCl, a fact that agrees well with the finding that K⁺ is intracellularly the dominant cation (Eisenberg and Wachtel 1987; Lanyi 1974). Similarly, the intracellular enzymes from the fermentative anaerobic *Bacteria* belonging to the order *Haloanaerobiales* generally functions better in the presence of molar concentrations of salt than in salt-free media, and they can be expected to be fully active at the actual salt concentration in the cytoplasm (Oren 2006).

The second strategy involving a “compatible solute” is used in most halophilic and halotolerant representatives of the *Bacteria*, in the halophilic methanogenic *Archaea*, and in eucaryal halophilic microorganisms. The term “compatible solute” was originally coined by Brown and Simpson (1972) to describe a low molecular weight solute that accumulates to a high intracellular concentration and that, by virtue of being a very poor enzyme inhibitor, protects enzymes against the

inhibition that would otherwise occur in solutions of low water availability (Oren 2002b).

The use of organic solutes as osmotic stabilizers was first recognized in the early 1970s for the eukaryotic alga *Dunaliella*, which can maintain extremely high intracellular glycerol concentrations (Ben-Amotz and Avron 1973). *Dunaliella salina* grown at 1.5 M NaCl was shown to possess an intracellular glycerol concentration of about 1.9 M, which is osmotically equivalent to 1.25 M NaCl (Degani et al. 1985). Cells grown in 4 M NaCl contain approximately 7.8 M glycerol inside, which is equivalent to a solution of 718 g/L glycerol in water (Brown 1990).

The accumulation of such compatible organic solutes may provide osmotic equilibrium while still enabling an activity of "conventional", non-salt-adapted enzymes (Galinski 1993; 1995). The concentrations of such osmotic solutes are regulated according to the salt concentration in which the cells live (Galinski and Louis 1999), and they can often be rapidly adjusted as required when the outside salinity is changed. Osmoadaptation, i.e., the physiological and genetic alterations that take place in the cell as the level of environmental water changes (Reed 1984), may involve *de novo* synthesis and/or uptake of suitable compounds from the medium upon salt upshock, as well as degradation, transformation into osmotically inactive forms, or excretion to the outer medium following dilution stress (Trüper and Galinski 1990).

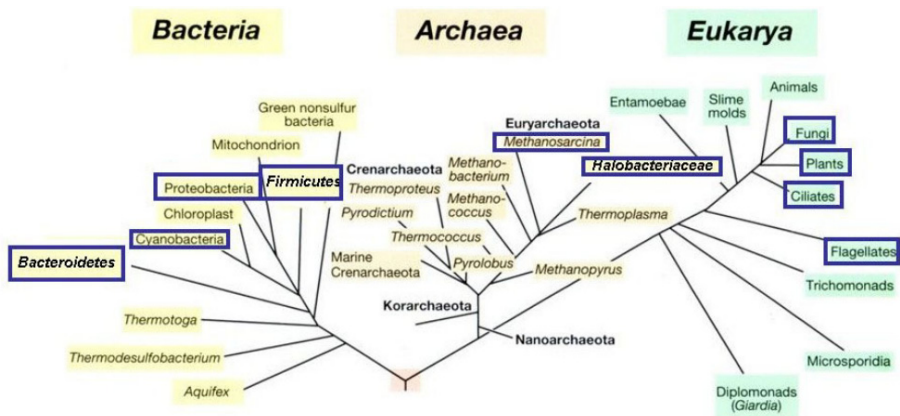

Figure 1. The universal phylogenetic tree of life as based on small subunit ribosomal RNA gene sequences, and the distribution of halophilic microorganisms within the tree. The groups marked with blue boxes contain at least one halophilic representative (Oren 2008)

2.3. Diversity of halophiles

Halophilic microorganisms from three domains of life, i.e., *Archaea*, *Bacteria*, and *Eucarya*, have been found to grow in high-salt environments (Figure 1). With an increasing salt concentration, the overall diversity of physiological groups decreases. Most microbial processes that occur in low-salinity environments are also found to take place at high salinities with exception of some processes (e.g. oxidation of ammonia to nitrite and oxidation of nitrite to nitrate, methanogenesis from acetate, and oxidation of acetate by sulfate-reducing bacteria) that have a certain salinity limit. The higher salinity limit at which each metabolic process takes place is correlated with the amount of energy demand and the energetic cost of osmotic adaptation (Oren 2002a).

2.3.1. Halophilic *Archaea*

Within the domain *Archaea*, halophilic microorganisms can be found in three families, i.e., *Halobacteriaceae*, *Methanospirillaceae*, and *Methanosarcinaceae*, all of which belong to the phylum *Euryarchaeota*. No halophilic representatives have yet been identified within the *Crenarchaeota*. The *Methanospirillaceae* and the *Methanosarcinaceae* contain halotolerant specimens as well as organisms that are adapted to seawater salinity and to hypersaline conditions. Some of these can grow at salt concentrations up to 300 g/L (Oren 2002b).

Most studies have been performed on the *Halobacteriaceae* family, which contains the extreme halophiles. These are strictly dependent on high salt concentrations for growth and structural stability. Most of them will not grow if the total salt concentration is below 2.5-3 M, and many species become damaged when suspended in solutions containing less than 1-2 M salt. The members of this family constitute the main components of the microbial biomass of such environments as the Dead Sea, hypersaline soda lakes, e.g., Lake Magadi, Kenya, and saltern crystallizer ponds. Most or all of the red colorations of such lakes are due to the C-50 carotenoid pigments (α -bacterioruberin and derivatives), found in large concentrations in the membranes of most members of the family (Oren 1994)

The understanding of the phylogenetic and physiological diversity within halophilic *Archaea* has greatly increased in recent times. For example, the 1974 edition of “Bergey’s Manual of Determinative Bacteriology” listed 2 genera and 3 species within the *Halobacteriaceae* family (Gibbons 1974). The numbers of genera and species increased to 14 and 34, respectively in 2001, and to date (March 2008) the names of no less than 26 genera and 91 different species of *Halobacteriaceae* have been validly published under the rules of the International Code of nomenclature of Prokaryotes (Oren 2008).

Halophilic *Archaea* have found a number of interesting applications in biotechnology, e.g., in the production of fermented foods in the Far East, degradation of toxic agents, and production of potentially useful products such as bacteriorhodopsin, biopolymers, and enzymes (Table 1) (Margesin and Schinner 2001; Oren 2002b; Ventosa and Nieto 1995).

Table 1. Applications of halophilic *Archaea* in biotechnology

Applications	<i>Archaea</i> strains	References
Fermented foods	Different halophilic <i>Archaea</i> (e.g. <i>Halobacterium</i> , <i>Halococcus</i>)	Thongthai and Suntinanalert 1991 Thongthai et al. 1992
Degradation of toxic agents	A strain designated EH4, <i>Haloferax</i> strain D1227, halophilic <i>Archaea</i> belonging to the genera <i>Haloarcula</i> , <i>Halobacterium</i> , and <i>Haloferax</i>	Bertrand et al. 1990 Oesterhelt et al. 1998 Oriel et al. 1997
Production of bacteriorhodopsin	<i>Halobacterium salinarum</i>	Margesin and Schinner 2001 Oren 2002b
Production of carotenoid pigments	Different members of the <i>Halobacteriaceae</i>	Javor 2002 Oren 2002b
Production of exopolysaccharides	<i>Haloferax mediterranei</i> <i>Haloferax volcanii</i> <i>Haloferax gibbonsii</i>	Paramonov et al. 1996 Rodriguez-Valera et al. 1991 Severina et al. 1989
Production of polyhydroxyalkanoate	<i>Haloferax mediterranei</i> <i>Haloarcula marismortui</i> <i>Natrialba</i> strain 56	Fernandez-Castillo et al. 1986 Hezayen et al. 2000 Kirk and Ginzburg 1972 Rodriguez-Valera et al. 1991
Production of poly(γ -D-glutamic acid)	<i>Natrialba aegyptiaca</i>	Hezayen et al. 2000
Production of enzymes	<i>Halobacterium salinarum</i> <i>Halobacterium sodomense</i> <i>Natronomonas pharaonis</i>	Bagai and Madamwar 1997 Chaga et al. 1993 Stan-Lotter et al. 1999 Oren 2002b

2.3.2. Halophilic *Bacteria*

Most characterized halophilic *Bacteria* belong to the γ -subdivision of the Proteobacteria, but moderate halophiles can be found in other subgroups.

Halophiles are also present among the cyanobacteria, the *Flavobacterium*, the spirochetes, the actinomycetes, as well as the low G+C and the high G+C Gram-positive *Bacteria* (Oren 2006).

Table 2. Biotechnological applications of halophilic *Bacteria*

Applications	<i>Bacteria</i> strains	References
Fermented foods	<i>Bacillus</i> sp. <i>Lactobacillus lactis</i> <i>Lactobacillus plantarum</i> <i>Pediococcus halophilus</i> <i>Tetragenococcus halophila</i> Moderately halophilic <i>Bacteria</i>	Araki et al. 1997 Röling and van Verseveld 1996 Thongthai and Suntinanalert 1991 Vilhelmsson et al. 1996 Villar et al. 1985
Degradation of toxic agents	<i>Bacillus cereus</i> <i>Halomonas halodurans</i> <i>Marinobacter hydrocarbonoclasticus</i> <i>Pseudomonas halodurans</i> <i>Staphylococcus</i> sp. Some strains belonging to the family <i>Halomonadaceae</i>	Azachi et al. 1995 Gauthier et al. 1992 Hinteregger and Streichsbier 1997 Maltseva et al. 1996 McMeekin et al. 1993 Oren et al. 1992 Rosenberg 1983 Ward and Brock 1978 Woolard and Irvine 1994
Production of compatible solutes	<i>Actinopolyspora halophila</i> <i>Ectothiorhodospira halochloris</i> <i>Halomonas elongata</i> <i>Marinococcus</i> M52	Frings et al. 1995 Galinski et al. 1985 Margesin and Schinner 2001 Sauer and Galinski 1998 Ventosa and Nieto 1995
Production of exopolysaccharides	Some bacteria of the genus <i>Halomonas</i> Some cyanobacteria	Bejar et al. 1998 Bouchotroch et al. 2000 Martínez-Cánovas et al. 2004 Matsunaga et al. 1996 Moreno et al. 1998 Shah et al. 1999
Production of polyhydroxyalkanoate	Most of bacteria of the genus <i>Halomonas</i>	Mata et al., 2002 Quillaguamán et al. 2005
Production of biosurfactants	<i>Bacillus licheniformis</i> JF-2 <i>Bacillus licheniformis</i> BAS50	Margesin and Schinner 2001 Thomas et al. 1993 Yakimov et al. 1995
Production of enzymes	Many halophilic <i>Bacteria</i>	Kamekura 1986 Onishi 1972 Onishi and Hidaka 1978 Onishi et al. 1983 Onishi and Sonoda 1979 Van Qua et al. 1981

In general, most halophiles within the domain *Bacteria* are moderate rather than extreme halophiles. A majority of halophilic bacteria adapt to high salt concentrations by accumulating organic compounds, i.e., using the “compatible solute” strategy (Oren 2008). The “salt-in” strategy can also be found in certain special groups. The low G+C branch of the Gram-positive *Bacteria*, the *Halanaerobiales*, encompass two families - the *Halanaerobiaceae* and the *Halobacteroidaceae* - consisting solely or mainly of halophilic anaerobic microorganisms, and the Gram-negative, extremely halophilic, aerobic bacterium *Salinibacter ruber* (Oren 1986; 2008).

The metabolic diversity of halophilic *Bacteria* is very wide: aerobic and anaerobic chemoheterotrophs, photoautotrophic and photoheterotrophic species, as well as the chemolithotrophs (Oren 2002b). Halophilic *Bacteria* have also played an important role in biotechnology as shown in Table 2 (Margesin and Schinner 2001; Oren 2002b; Ventosa and Nieto 1995).

A moderate halophilic bacterium *Halomonas boliviensis* LC1

Halomonas boliviensis LC1 (=DSM 15516^T) is an aerobic bacterium, motile, Gram-negative, with rod-shaped cells, which has been isolated from a sample of soil from around a hypersaline lake Laguna Colorada (Bolivia) (Quillaguamán et al. 2004). The colonies are circular with undulate margins, convex and have a cream pigmentation that becomes enhanced in old cultures. *H. boliviensis* belongs to genus *Halomonas*, family *Halomonadaceae*, order *Oceanospirillales*, and class *Gammaproteobacteria*. This strain is able to utilize various carbohydrates as carbon sources (fructose, glucose, mannose, sucrose, maltose, trehalose, L-arabinose, D-xylose). *H. boliviensis* can grow over a wide range of NaCl concentrations (0-25 %, w/v) in complex media, with an optimum of about 4.5 % (w/v) NaCl. Growth occurs at pH 6–11, with an optimum between 7.5 and 8. The temperature range for growth is 0–45 °C, with an optimum between 25 and 30 °C (Quillaguamán et al. 2004).

H. boliviensis grows on a variety of carbon sources and accumulates poly(3-hydroxybutyrate) under conditions of nitrogen limitation (Quillaguamán et al. 2005; 2006; 2007; **Paper I; II; III**). The organism adapts to the saline environment by accumulation of ectoine and hydroxyectoine (**Paper III; IV; V**).

2.3.3. Halophilic *Eucarya*

The diversity of eukaryotic microorganisms, capable of growing at elevated salinities, is relatively restricted. However, *Eucarya* contribute significantly to the biota of hypersaline environments. Green algae of the genus *Dunaliella* are the

main or sole primary producers in environments that are too salty for even the best salt-adapted among the cyanobacteria. *Dunaliella* accumulate large amounts of glycerol as a compatible solute in response to osmotic stress (Ben-Amotz and Avron 1973). Some *Dunaliella* species can also accumulate large amounts of β -carotene (up to 10 % or more of the total cell dry weight) (Borowitzka, 1986).

The presence of fungal life in hypersaline environments has recently been demonstrated. Three species of filamentous fungi from surface water samples of Dead Sea were isolated. They did not grow on agar media without salt, but grew on agar prepared with up to 50% Dead Sea water (Buchalo et al. 1998). Black yeasts such as *Hortaea werneckii*, *Phaeotheca triangularis*, *Trimmatostroma salinum*, and *Aureobasidium pullulans* were isolated from hypersaline waters (3-30 % NaCl), *H. werneckii*, *P. triangularis* and *T. salinum* are not found outside saline environments (Gunde-Cimerman et al. 2000; Zalar et al. 1999). The survival of filamentous fungi such as *Cladosporium*, *Aspergillus*, and *Penicillium* spp. in hypersaline environments has recently been reported (Gunde-Cimerman et al. 2000; 2005; Kis-Papo et al. 2003)

Protozoa have also been reported from hypersaline lakes. Ten zooflagellates and four sarcodines were frequently observed in brines (Hutt Lagoon, Western Australia) with > 150 g/L salt (Post et al. 1983).

Examples on the industrial applications of halophilic *Eucarya* are scarce - perhaps due to the restriction of their recent discovery. Only the halophilic unicellular green alga *Dunaliella* is grown worldwide as a source of valuable products such as β -carotene, glycerol, and oil (by pyrolysis of *Dunaliella* biomass) (Oren 2002b).

3. Biopolyesters: synthesis, properties, and applications of polyhydroxyalkanoates

Plastics, for which the current global consumption is more than 200 million tonnes (approx. 40 million tonnes in the European Union) and the annual growth is approximately 5 %, represent the largest field of application for crude oil outside the energy and transport sectors (<http://www.european-bioplastics.org>). Polyethylene, polypropylene, and polyvinylchloride are some of the most used materials because of their low cost (c.a. 1\$ per kg) (Panda et al. 2006). However, it is well known that these polymers are not biologically degradable, and thus cause an increase in the solid waste stream with negative environmental effects. For instance, about forty percent of plastics produced are discarded into landfills and several hundred thousands of tonnes of plastics are discarded each year into marine environments, accumulating in oceanic regions (Reddy et al. 2003). In order to overcome the problem of pollution caused by non-degradable plastics, there is considerable interest in the development of biodegradable polymers (Salehizadeh and Van Loosdrecht 2004). There are currently a few such materials on the market: starch-based plastics, polylactic acid (PLA), polyhydroxyalkanoates (PHAs), and cellulose derivatives (<http://www.european-bioplastics.org>).

3.1. Polyhydroxyalkanoates

Among the various biodegradable polymer materials, polyhydroxyalkanoates (PHAs) provide a good fully degradable alternative to petrochemical plastics. PHA is a polyester of hydroxyalkanoates (Figure 2) that accumulates intracellularly as carbon and energy storage materials in numerous microorganisms, usually when grown under the limitation of a nutrient such as oxygen, nitrogen, phosphate, sulphur, or magnesium and in the presence of excess carbon (Anderson and Dawes 1990; Valappil et al. 2007). PHA is typically produced as a polymer of 10^3 to 10^4 monomers (Suriyamongkol et al. 2007), which exists as discrete granules, with about 5 to 13 granules per cell and with diameters of 0.2 to 0.5 μm (Lee 1996a; Sudesh et al. 2000). The properties of PHAs are similar to those of common petrochemical-based synthetic thermoplastics and can hence potentially replace them. Furthermore, they become completely degraded to carbon dioxide and water under aerobic conditions and to methane and carbon dioxide under anaerobic

conditions by microorganisms in the environment (Anderson and Dawes 1990; Lee 1996b).

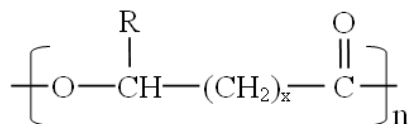

Figure 2. The general structure of polyhydroxyalkanoates.
R = H or alkyl groups C₁-C₁₃, x = 1-4, and n = 100-30 000

Since PHB was first discovered in 1926 (Lemoigne 1926), about 150 different constituents have been observed in PHAs isolated from more than 300 microorganisms (Salehizadeh and Van Loosdrecht 2004; Steinbüchel and Valentin 1995; Valappil et al. 2007). PHA can be polymerized from a single monomer or represent a co-polymer of two or more different monomers. PHAs can be divided into two groups depending on the number of carbon atoms in the monomer units: short-chain-length (scl) PHAs with C₃-C₅ hydroxyacids as monomers and medium-chain-length (mcl) PHAs with C₆-C₁₆ hydroxyacids as monomers. The scl-PHAs have properties close to the conventional plastics (stiff and brittle) while mcl-PHAs are flexible, present low crystallinities, tensile strengths and melting points (Philip et al. 2007). Certain bacteria are able to synthesize PHAs containing both scl- and mcl-monomer units (Philip et al. 2007). The molecular weight of PHA generally varies between 2×10^5 and 3×10^6 Daltons. The composition and molecular weight of the synthesized polymer are governed by two factors: the microbial strains and the provided substrate (mainly the carbon source) (Valappil et al. 2007).

Previous studies have shown that several bacteria can accumulate high levels of PHA per cell dry weight (Kim et al. 1994a; 1994b; Wang and Lee 1997). They can be divided into two groups, of which the first includes *Alcaligenes eutrophus* (now renamed, *Cupriavidus necator*), *Protomonas extorquens*, and *Pseudomonas oleovorans*. These bacteria require limitations of essential nutrients (such as nitrogen, magnesium, phosphorous or sulphur) while those of the second group, i.e., *Alcaligenes latus* and *Azotobacter vinelandii*, require no such nutrient limitations (Lee 1996b). Nonetheless, the PHA content can be increased if a nutrient limitation is applied (Wang and Lee 1997).

Poly(3-hydroxybutyrate) (PHB) is a homopolymer of 3-hydroxybutyrate and represents the most widespread and best characterized member of the PHAs. PHB has attracted much interest due to its material properties being comparable to those of polypropylene (Table 3), and because of its potential ecological advantages with regards to production from renewable resources, e.g., sugars, fatty acids,

starch, cellulose, and plant oil (Reddy et al. 2003; Tokiwa and Ugwu 2007) and in undergoing rapid degradation on disposal in the environment.

Table 3. A comparison of the physical properties of various PHAs and polypropylene. Data were obtained from Doi 1997; Khanna and Srivastava 2005; Tsuge 2002

Polymer	T _m ¹ (°C)	T _g ² (°C)	Crystallinity ³ (%)	Tensile strength ⁴ (MPa)	Extension to break ⁵ (%)
P(3HB)	175-179	4	60-80	40	5-6
P(4HB)	53	-48	34	104	1000
P(3HB-co-3 mol% 3HV)	169-170	-1	69	38	-
P(3HB-co-14 mol% 3HV)	150	-	56	35	-
P(3HB-co-20 mol% 3HV)	145	-1	50	32	50
P(3HB-co-25 mol% 3HV)	137	-1	40	30	-
P(3HB-co-16 mol% 4HB)	150	-7	45	26	444
P(3HB-co-64 mol% 4HB)	50	-35	15	17	591
P(3HB-co-90 mol% 4HB)	50	-42	28	65	1080
P(3HB-co-6 mol% 3HA)	133	-8	45	17	680
P(3HB-co-10 mol% 3HHx)	127	-1	34	21	400
P(3HO-co-11 mol% 3HHx)	61	-36	30	10	300
Polypropylene	176	-10	50-70	34.5-38	400

¹Melting temperature is the temperature at which a polymer changes from solid to liquid state

²Glass-transition temperature is the temperature at which the amorphous phase of the polymer is converted between rubbery and glassy states.

³Percent crystallinity is the ratio of crystalline material to total material (crystalline + amorphous)

⁴Tensile strength is the maximum stress a material subjected to the stretching load can withstand without tearing

⁵Extension to break represents the percent change in length at the material failure

There are two major drawbacks to the commercial use of PHB. First, PHB has a poor thermal stability since it starts to degrade at approximately 185 °C (Tokiwa and Ugwu 2007), which is close to its melting temperature (175-179 °C). Second, PHB becomes stiff and brittle over a period of several days upon storage under ambient conditions. To improve the physical properties of microbially produced PHB, several attempts have been made to synthesize copolymers of 3HB. For instance, poly(3-hydroxybutyrate-co-3-hydroxyvalerate) (P[3HB-3HV]) was successfully produced on a commercial basis under the trade name of BIOPOL® (now produced by Metabolix) (Philip et al. 2007; Tokiwa and Ugwu 2007). The copolymer is a thermoplastic and has a melting point in the range of 140-170 °C. With an increase in the amount of 3HV in the copolymer, the crystallinity decreases and the polymer becomes more elastic (Table 3). BIOPOL® can be used to coat paper and paperboards. In addition to being suitable for injection, blow

molding and film production, BIOPOL® has antistatic properties that can be exploited for electric and electronic packaging (Philip et al. 2007). The first commercial plant with a capacity to produce 50 000 tonnes of PHA per year was planned to be set up by Metabolix and ADM (Archer Daniels Midland Company, Decatur, IL, USA) (Philip et al. 2007).

3.2. Polyhydroxyalkanoates in halophiles

3.2.1. PHA accumulation in halophilic *Archaea*

PHA accumulation in *Archaea* was first reported during the characterization of halophilic strains, *Haloarcula marismortui* and *Haloferax mediterranei* (Fernandez-Castillo et al. 1986; Kirk and Ginzburg 1972). Recently, taxonomic studies on haloarchaea have revealed that certain species are able to synthesize PHA, e.g., *Haloterrigena hispanica*, *Haloquadratum walsbyi*, *Halorhabdus tiamatea*, *Halorhabdus utahensis*, and *Natrinema altinense* (Antunes et al. 2008; Burns et al. 2007; Romano et al. 2007; Waino et al. 2000; Xu et al. 2005). Among them, the archaeon *Hfx. mediterranei* is so far the best PHA producer of the *Halobacteriaceae* family. *Hfx. mediterranei* accumulates large amounts of PHA (up to 65 % of the cell dry weight), when using starch or glucose as the carbon source, in batch cultures grown under conditions of phosphorous limitation (Rodriguez-Valera and Lillo 1992). *Hfx. mediterranei* can produce the co-polymer poly(3-hydroxybutyrate-co-3-hydroxyvalerate) P(3HB-co-3HV), containing 10.7 % of 3HV when cultured by fed-batch fermentation with glucose as the carbon source (Don et al. 2006). A maximum PHA content of 48.6 % and a volumetric productivity of about 0.36 g/L/h were reached under these conditions. Another co-polymer poly(3-hydroxybutyrate-co-3-hydroxyvalerate-co-4-hydroxybutyrate) P(3HB-co-3HV-co-4HB) can be accumulated by *Hfx. mediterranei* when the medium was supplemented with a combination of carbon sources (hydrolyzed whey, γ -butyrolactone, and valerate) (Koller et al. 2007). A high PHA content of 87.5 % and a PHA productivity of 0.14 g/L/h were obtained, as described in this work.

3.2.2. PHA accumulation in halophilic bacteria of the family *Halomonadaceae*

The *Halomonadaceae* family is currently composed of seven genera and more than sixty-five different species (as of July 2009). PHA accumulation in these microorganisms has been recognized as a useful phenotypic marker that can be of aid for distinguishing between species (Mata et al. 2002). Figure 3 depicts the phylogenetic relationship of the species in the *Halomonadaceae* which are capable

of accumulating PHA. Thirty-two species are known to synthesize PHA (Figure 3), although the capability of storing PHA has not been determined for several of them. The ability of these strains to use various cheap substrates has been exploited for the production of PHB by *Halomonas boliviensis*, the most extensively studied species of the *Halomonadaceae* family regarding polyester production (Section 5). Recently, *Cobetia marina* was also found to accumulate large amounts of PHA, reaching 81 wt% in a two-step cultivation system with glucose and valerate as carbon sources. The synthesized co-polymer contains 88.1 mol% 3HB and 12.8 mol% 3HV monomers respectively (Biwas et al. 2009).

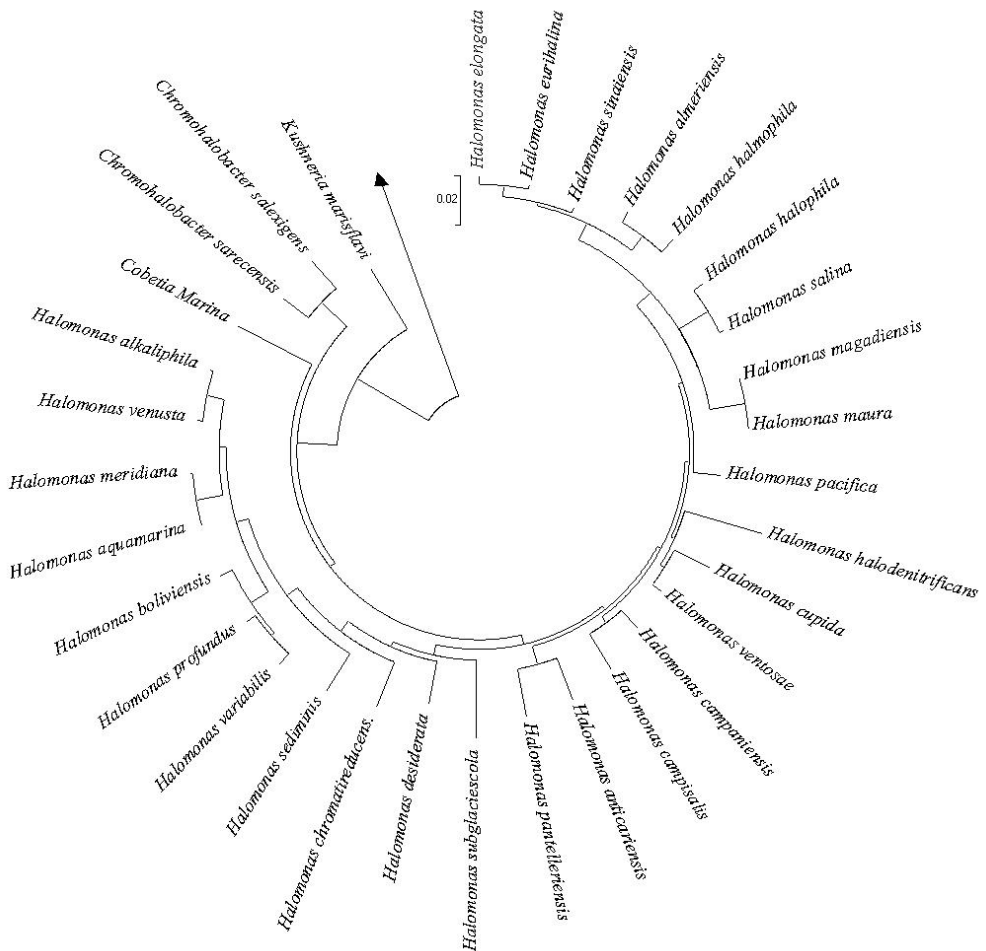

Figure 3. The phylogenetic tree of microorganisms of the *Halomonadaceae* family, capable of synthesizing PHA. The tree was constructed using the neighbor-joining method with the MEGA 4.0 software package. Bar 0.02 substitutions per site. *Escherichia coli* was the outgroup bacterium taken to root the tree (Modified from Quillaguamán et al. 2009)

3.3. PHA biosynthesis

PHA can be produced from a wide variety of renewable resources, including pure sugars (glucose, xylose, sucrose) (Bertrand et al. 1990; Quillaguamán et al. 2006; 2007; **Paper II**), biomacromolecules (starch, cellulose) (Halami 2008; Thomas et al. 2006), and byproducts (molasses, whey, wheat bran, corn steep liquor) (Ahn et al. 2000; Vijayendra et al. 2007; **Paper I**), as well as fossil resources (methane, mineral oil, lignite, hard coal) (Mothes et al. 2007; Reddy et al. 2003), chemicals (acetate, propionic acid, butyric acid) (Shi et al. 1997; **Paper I**) and carbon dioxide (Ishizaki et al. 2001). The metabolic pathway of PHA synthesis in bacteria from different carbon sources is summarized in Figure 4. The carbon source is first transferred from the extracellular environment into the cells by a specific transport system or diffusion. The carbon source is then converted into an (R)-hydroxyacyl-CoA thioesters (a substrate of the PHA synthase) by anabolic or catabolic reactions, or both. Finally, PHA synthase, which is the key enzyme of PHA synthesis, uses (R)-hydroxyacyl-CoA thioesters as the substrate and catalyzes the formation of PHA inclusions with a concomitant release of coenzyme A (Steinbüchel and Valentin 1995).

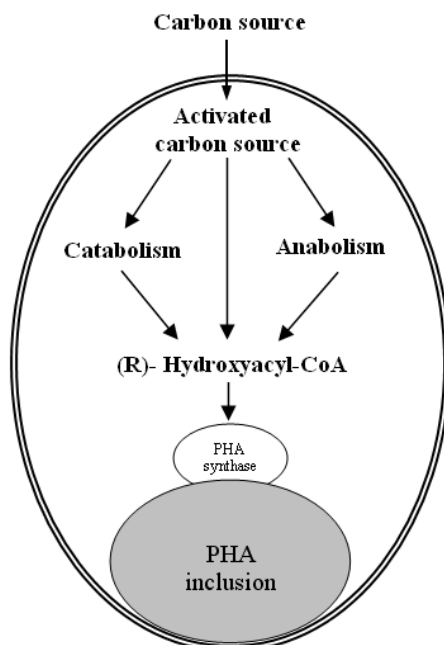









Figure 4. A schematic representation of the biosynthesis of PHA in bacteria (modified from Steinbüchel and Valentin 1995)

Recently, the nucleotide sequences of at least 88 PHA synthase genes from at least 68 bacteria have been investigated (Rehm 2007). Depending on the enzyme composition and the substrate specificity of the enzymes, PHA synthases can be divided into four major classes. Class I and class II PHA synthases consist of only one type of subunit (PhaC). PHA synthases belonging to class I (e.g., in *Cupriavidus necator*) utilize CoA thioesters of 3-HAs, 4-HAs, and 5-HAs comprising 3 to 5 carbon atoms as substrates in order to synthesize short-chain-length PHA, whereas class II PHA synthases (e.g., in *Pseudomonas aeruginosa*) preferentially utilize the CoA thioester of 3-HAs comprising 6 to 14 carbon atoms (for the synthesis of medium-chain-length PHA). PHA synthases in class III are composed of two types of subunits (PhaC and PhaE) possessing substrate specificities similar to those of class I, and can also polymerize 3-HAs with 6 to 8 carbon atoms. Also the PHA synthases of class IV are composed of two subunits (PhaC and PhaR) that utilize 3-HAs with 3-5 carbon atoms as the substrate (Table 4) (Rehm 2003; 2007).

Table 4. The four classes of PHA synthases (modified from Rehm 2003)

Class	PHA synthase genes	Subunits	Species	Substrate
I		 ~60-73 kDa	<i>Cupriavidus necator</i>	3HA _{SCL} -CoA (~C3-C5) 4HA _{SCL} -CoA, 5HA _{SCL} -CoA, 3MA _{SCL} -CoA
II		 ~60-65 kDa	<i>Pseudomonas aeruginosa</i>	3HA _{MCL} -CoA (~≥C5)
III		 ~40 kDa ~40 kDa	<i>Allochrotaium vinosum</i>	3HA _{SCL} -CoA (3HA _{MCL} -CoA [-C6-C8], 4HA-CoA, 5HA-CoA)
IV		 ~40 kDa ~22 kDa	<i>Bacillus megaterium</i>	3HA _{SCL} -CoA

In general, the PHA synthase genes, as well as those for other proteins related to the metabolism of PHA, are clustered in the bacterial genomes. For instance, in *C. necator*, which has been extensively studied (Reddy et al. 2003), the three PHB biosynthesis genes are clustered in one operon, denoted as the *phbCAB* operon, and encode for three enzymes catalyzing three consecutive reactions (Figure 5). The first reaction consists of the condensation of two acetyl coenzyme A (Acetyl-CoA) molecules into acetoacetyl-CoA by β -ketoacyl-CoA thiolase (encoded by *phbA*). The second reaction is the reduction of acetoacetyl-CoA to (*R*)-3-hydroxybutyryl-CoA by NADP-dependent acetoacetyl-CoA reductase (encoded by *phbB*). Lastly, the (*R*)-3-hydroxybutyryl-CoA monomers are polymerized into poly(3-hydroxybutyrate) (PHB) by PHB polymerase (encoded by *phbC*) (Madison and Huisman 1999). PHB accumulates as a granule but can be degraded by

intracellular PHB depolymerase and oligomer hydrolase to form 3-HB and oligomers of 3-HB (Tokiwa and Ugwu 2007).

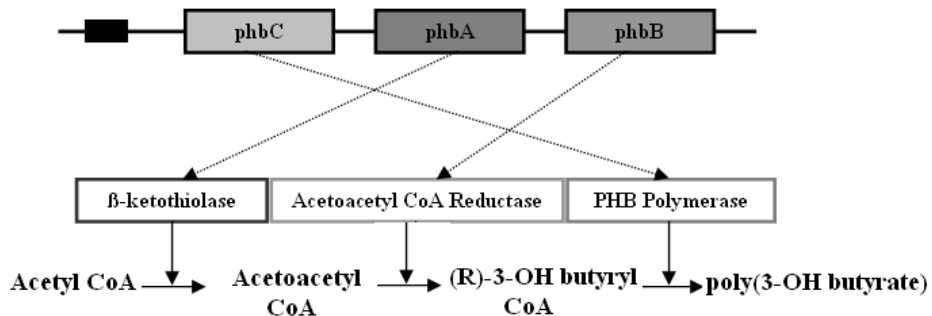

Figure 5. The biosynthetic pathway of PHB consisting of three steps with the successive action of three enzymes: β -ketoacyl-CoA thiolase (*phbA*), acetoacetyl-CoA reductase (*phbB*), and PHB polymerase (*phbC*), which is encoded by the genes of the *phbCAB* operon. A promoter upstream of *phbC* transcribes the complete operon (modified from Madison and Huisman 1999)

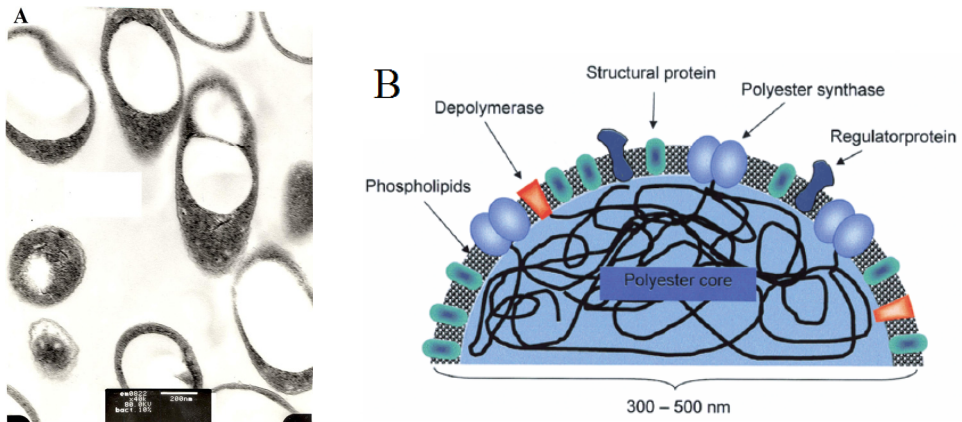

Figure 6. Different representations of PHA granules. (A) A Transmission Electron Microscopy image of *H. boliviensis* cells filled with PHA granules (Quillaguamán et al. 2006). (B) A schematic representation of a PHA granule with associated proteins (Rehm 2003)

Within the cells, PHAs exist as insoluble spherical inclusions or PHA granules made up of a polyester core, surrounded by a boundary layer (phospholipids membrane) with embedded or attached proteins that include the PHA synthase (PhaC), phasin protein (PhaP), PHA depolymerase (PhaZ), regulatory protein (PhaR), and additional proteins with, as of yet, unknown functions (Figure 6) (Rehm 2003; Grage et al. 2009). PHA granules increase in size while the attached

PHA synthases continuously incorporate precursor from the cytosol into the growing polyester chain. PHA granules are deposited intracellularly, filling almost the entire cell volume, when maximum PHA accumulation is achieved (Rehm 2003).

3.4. Properties and applications of PHA

After extraction from the cells, PHAs possess the common features of non-toxic, biocompatible, biodegradable and recyclable thermoplastics. They are thus highly crystalline, optically active, piezoelectric and insoluble in water. In addition, the large diversity of monomers found in PHAs provides a wide spectrum of polymers with varying physical properties. These features render them highly competitive with polypropylene or other petroleum-derived plastics (Madison and Huisman 1999; Reddy et al. 2003).

The main applications of PHAs include replacing petrochemical polymers currently in use for packaging and coating, as well as disposable items such as razors, utensils, diapers, feminine hygiene products, and cosmetic containers such as shampoo bottles and cups. In addition to their potential use as plastic materials, PHAs are also useful as stereoregular compounds that can serve as chiral precursors for the chemical synthesis of optically active compounds. Such compounds are particularly used as biodegradable carriers for long-term dosage of drugs, medicines, hormones, insecticides and herbicides. They are also widely employed as bone plates, osteosynthetic materials, surgical sutures, vascular grafts and heart valves (Philip et al. 2007; Reddy et al. 2003).

The large molecular weight of the spherical structure of PHA granules with surface-associated proteins as well as their low-cost production render these granules useful tools for protein immobilization and purification (Grage et al. 2009). For example, Banki et al. (2005) developed a protein purification system, in which the protein of interest was produced fused to the C terminus of PhaP which acted as an affinity tag. The tagged protein and the PHA granules were coproduced in *E. coli*, and the granules behaved as affinity matrix for the protein. After cell disruption, granules with bound protein can be separated from other cellular components by centrifugation. Following an appropriate washing, the product protein is self-cleaved from the granules and released into solution in a substantially purified form. In addition, Peters and Rehm (2005) demonstrated that the fusion of green fluorescent protein (GFP) to the N terminus of the PHA synthase did not affect PHA granule formation. Further studies with regard to engineering the PHA synthase in order to enable an immobilization of β -galactosidase demonstrated that the immobilized *enzyme* was stable for several months under various storage conditions. This study suggested that protein

engineering of the PHA synthase in order to produce functionalized PHA granules could be a useful tool for developing biological nano-/micro-beads for a variety of applications (Grage et al. 2009).

4. Compatible solutes and their applications

In general, microorganisms can accumulate osmolytes by *de novo* synthesis or/and by uptake from the medium without interfering with vital cellular processes (Poolman and Glaasker 1998; Roberts 2005). Accumulation of osmolytes helps to maintain the turgor pressure, cell volume, and electrolyte concentration, which are all important conditions for cell proliferation (Roberts 2005). The concentration of osmolytes in the cells can range from millimolar to 1-2 M in response to the extracellular osmolarity (Lentzen and Schwarz 2006). The organic osmolytes include sugars, polyols, phosphodiesteres, glyceric acid derivatives, amino acids and their respective derivatives, ectoines and betaines (Figure 7) (Roberts 2005). Organic compatible solutes make up the major part of the osmotically active compounds in the cells' cytoplasm. Compatible solutes are polar, highly soluble molecules, most of which are either uncharged or zwitterionic at physiological pH (Roberts 2005).

It is very interesting to note that most archaeal compatible solutes resemble their bacterial counterparts in structure, with the difference that the majority of them carry a negative charge (Martins et al. 1999). This anionic character is conferred to the solutes by the addition of a carboxylic, phosphate or sulphate group. A conceivable explanation for this preference for anionic solutes is that it contributes to equilibrate the high intracellular concentration of inorganic cations, primarily K^+ , found in most archaea.

Halotolerant and halophilic organisms accumulate a few different molecules for osmotic balance; a typical bacterial or archaeal cell accumulates several molecules (cocktail of organic solutes) that together contribute to osmotic balance. Sometimes this corresponds to a combination of anions and zwitterions, but it is often represented by several solutes with the same net charge (Roberts 2005).

The present studies have been focused on ectoines [1,4,5,6-tetrahydro-2-methyl-4-pyrimidinecarboxylic acid (ectoine) and 1,4,5,6-tetrahydro-2-methyl-5-hydroxy-4-pyrimidinecarboxylic acid (hydroxyectoine)], which is well known as the most abundant compatible solute, accumulated intracellularly by many halotolerant and halophilic bacteria for osmotic stress protection (Roberts 2005; Lentzen and Schwarz 2006).

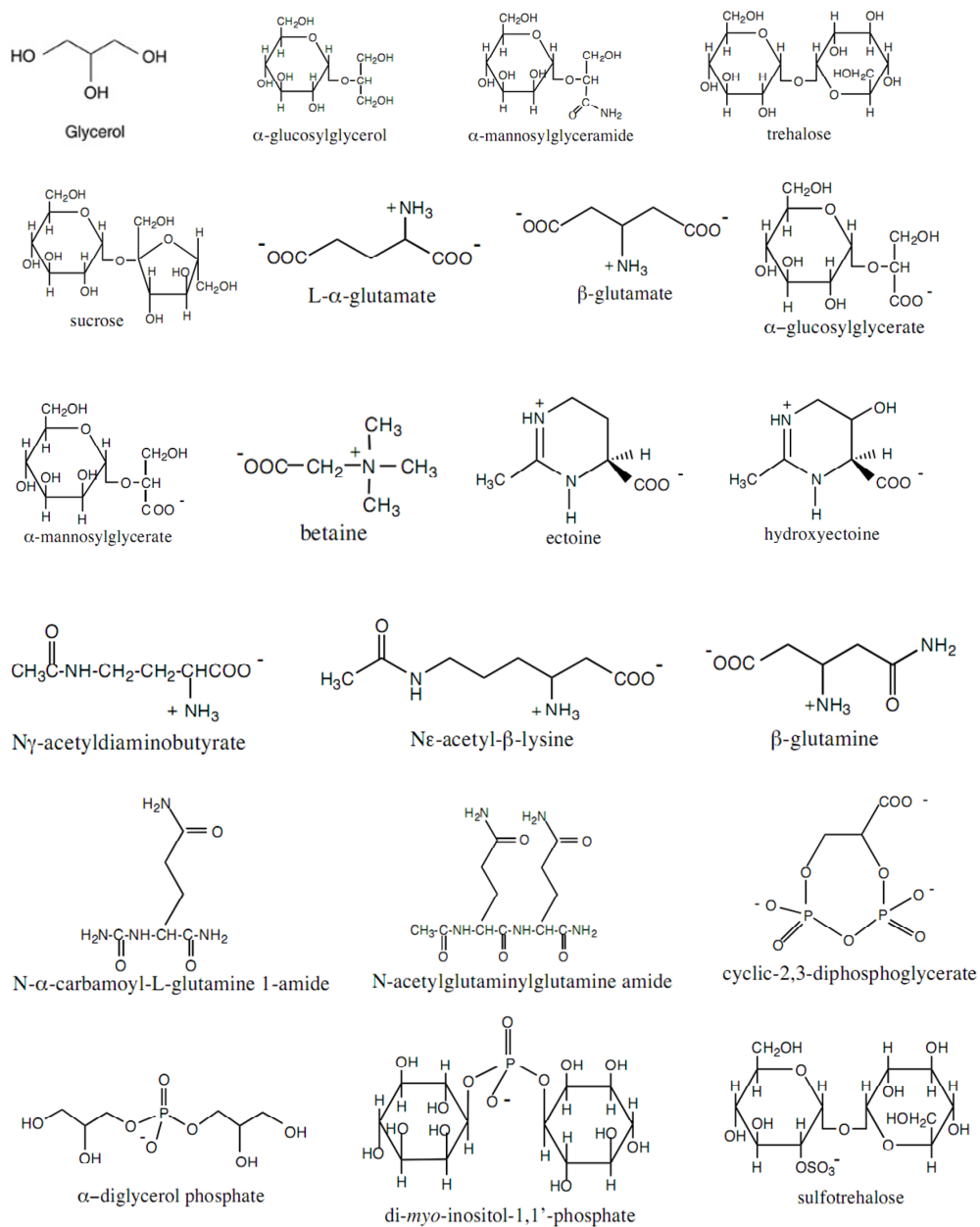

Figure 7. Important compatible solutes synthesized by halophilic and/or halotolerant microorganisms

4.1. Uptake of compatible solutes in bacteria

The cells may synthesize some of the compatible solutes after osmotic upshock and degrade and/or release them after an osmotic downshock, but the initial response is much more rapid if compatible solutes can be absorbed from the surrounding medium (Poolman and Glaasker 1998). These compounds are released into ecosystems by primary microbial producers from osmotically downshocked cells: by decaying microbial, plant, and animal cells; by root exudates; and by the excretion fluids of mammals (Bremer and Kraemer 2000). The accumulation of compatible solutes from exogenous sources generally inhibits endogenous synthesis, at least over a certain range of osmolarities (Sleator and Hill 2001).

In natural ecosystems, the supply of osmoprotectants and their biosynthetic precursors is generally very low, with concentrations that are usually in the nanomolar to micromolar range (Bremer and Kraemer 2000). Therefore, osmoprotectant transporters commonly exhibit very high affinities for their major substrates, and their capacity is geared to permit accumulation of compatible solutes to molar concentrations. In addition, to take advantage of the spectrum of osmoprotectants available in the ecosystem, microorganisms often possess several transport systems, some of which exhibit broad substrate specificities (Bremer and Kraemer 2000). There are basically two transport systems that catalyze uptake of compatible solutes: secondary transporters that use either the proton motive force or sodium motive force to drive the accumulation of compatible solutes, and ATP binding cassette (ABC) transporters that couple ATP hydrolysis to uptake (Pflüger and Müller 2004; Roberts 2005).

Earlier studies have demonstrated that ectoine can be internalized by certain microorganisms when it is provided in the medium (Grammann et al. 2002; Jebbar et al. 2005). In *Halomonas elongata*, the transporter for ectoine accumulation (TeaABC) was identified (Grammann et al. 2002). This transporter is similar to members of the tripartite ATP-independent periplasmic transporter family (TRAP-T), which consist of three nonhomologous proteins: a large transmembrane protein, a small transmembrane protein, and a periplasmic substrate-binding protein. The transport activity is not linked to ATP hydrolysis but is coupled to the co-transport of protons or Na⁺ (Grammann et al. 2002). A proteomic analysis of *Sinorhizobium meliloti* in a medium supplemented with ectoine detected an increased synthesis of ten proteins. Five of these genes, with four other genes whose products were not detected on two-dimensional gels, belong to the same gene cluster, which is localized on the pSymB megaplasmid. Four of the nine genes were found to encode the characteristic components of an ATP-binding cassette transporter named ehu, for ectoine/hydroxyectoine uptake (Jebbar et al. 2005).

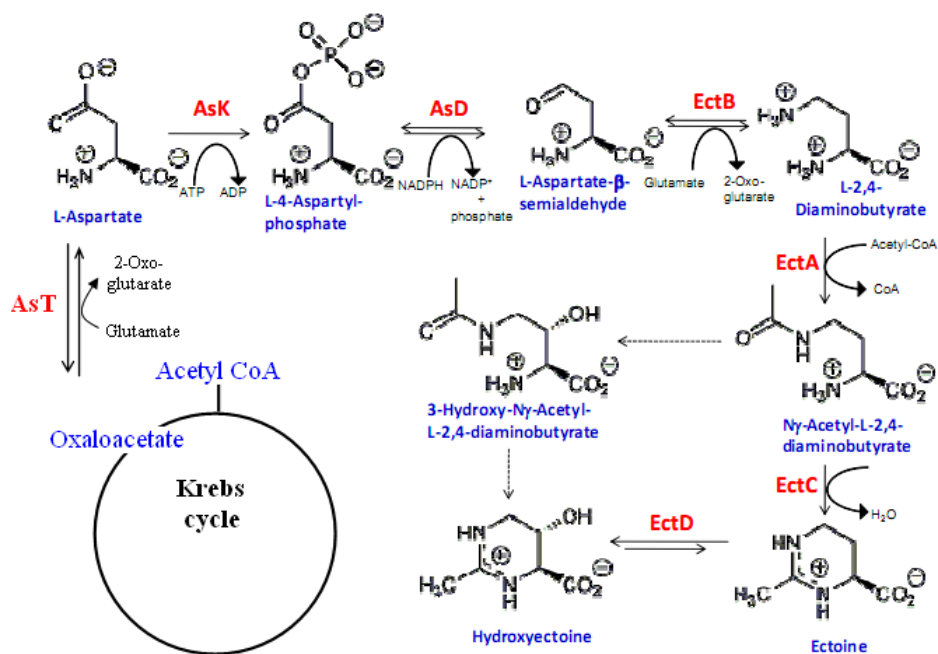

Figure 8. The biosynthetic pathway of ectoines in bacteria. The solid and dashed lines indicate established and proposed steps. The enzymes involved are Aspartate transaminase (AsT), Aspartate kinase (AsK), Aspartate semialdehyde dehydrogenase (AsD), L-diaminobutyric acid transaminase (EctB), L-diaminobutyric acid acetyltransferase (EctA), ectoine synthase (EctC), and ectoine hydroxylase (EctD) (Modified from Vargas et al. 2008)

4.2. Synthesis of compatible solutes (ectoines)

Ectoine and hydroxyectoine are the most widespread compatible solutes synthesized *de novo* by aerobic heterotrophic bacteria (Lentzen and Schwarz 2006; Oren 2002). Ectoine was originally discovered in the extremely halophilic phototrophic sulfobacterium *Ectothiorhodospira halochloris* (Galinski et al. 1985), whereas hydroxyectoine was first discovered in the actinomycin D producer *Streptomyces parvulus* (Inbar and Lapidot 1988).

Ectoine is synthesized from aspartate semialdehyde. As shown in Figure 8, the aldehyde is converted to L-2,4-diaminobutyrate (DA) by L-2,4-diaminobutyric acid transaminase (EctB), after which DA is acetylated to form N γ -acetyl-L-2,4-diaminobutyrate (NADA) by L-2,4-diaminobutyric acid acetyltransferase (EctA). The final step is the cyclization of NADA to form ectoine by the action of L-ectoine synthase (EctC). The *ectABC* gene cluster involved in the synthesis of

ectoine has been isolated from *Chromohalobacter salexigens* (Cánovas et al. 1997), from *Marinococcus halophilus* (Louis and Galinski 1997), and from *Halomonas elongata* (Göller et al. 1998).

Two biosynthesis pathways have been proposed for the formation of hydroxyectoine, either directly from ectoine or via an alternative pathway that converts N γ -acetyldiaminobutyric acid to hydroxyectoine without the involvement of ectoine (Figure 8) (Cánovas et al. 1999; García-Esteba et al. 2006; Göller et al. 1998; Louis and Galinski 1997; Vargas et al. 2008). The ectoine hydroxylase gene (*ectD*) responsible for the conversion of ectoine to hydroxyectoine in *C. salexigens* has been isolated and characterized (García-Esteba et al. 2006). However, the gene responsible for hydroxyectoine biosynthesis from NADA has not been isolated. The formation of hydroxyectoine from NADA is evident from the results of previous studies performed with *H. elongata* (Cánovas et al. 1999). The mutant strain, which is affected in diaminobutyric acid acetyltransferase gene (*ectA*), cannot synthesize ectoine or hydroxyectoine, whereas another mutant strain, which is affected in the ectoine synthase gene (*ectC*), can synthesize both of them (Cánovas et al. 1999). These results suggest that hydroxyectoine may be synthesized via a two-step pathway involving hydroxylation of NADA to produce 3-hydroxyl-N γ -acetyldiaminobutyrate, which is subsequently converted to hydroxyectoine by the action of a putative hydroxyectoine synthase (Figure 8). In addition, the results indicate not only that hydroxyectoine can be synthesized directly from ectoine but also that a reversible reaction can convert hydroxyectoine into ectoine (Figure 8).

4.3. Release of compatible solutes

The survival and growth of microorganisms in high-osmolality environments lead to the massive intracellular accumulation of compatible solutes and ions. In their natural ecosystems, microorganisms are likely to experience osmotic downshocks caused by rain, flooding, and washout into freshwater sources (Kempf and Bremer 1998). Such conditions result in a rapid movement of water into the cells. To avoid cell lysis, microorganisms must immediately eliminate the accumulated organic osmolytes and ions to reduce the driving force of water entry. A simple and easy way that has been found for a number of microorganisms involves the rapid release of the organic osmolytes and other solutes from the cells into the surrounding medium through membrane-tension-gated channels (Bremer and Krämer 2000). For instance, in *E. coli*, a rapid release of K⁺, glutamate and trehalose is observed upon an osmotic downshock, whereas the levels of solutes such as alanine, lysine and arginine remain approximately constant in the cells (Schleyer et al. 1993). When *Lactobacillus plantarum* is subjected to an osmotic downshock, a rapid efflux of accumulated glycine betaine, proline, and alanine

occurs, whereas the pools of other amino acids remain unaffected (Glaasker et al. 1996). *H. elongata* and *Brevibacterium epidermis* rapidly release ectoine to achieve osmotic equilibrium under hypo-osmotic shock conditions (Onraedt et al. 2005; Sauer and Galinski 1998).

Electrophysiological studies with the patch-clamp technique have revealed that the cytoplasmic membranes of both *Bacteria* and *Archaea* contain gated channels with various levels of conductances (Berrier et al. 1996; Le Dain et al. 1998). Since their discovery in bacteria, mechanosensitive (MS) channels have been proposed to play a role in the sensing of and response to osmotic changes. They also serve as safety valves for the release of solutes when the environmental osmolality suddenly drops (Blount et al. 1997; Sukharev et al. 1997). Three channel activities have been found in *E. coli*: MscL (MS channel of large conductance), MscS (smaller conductance), and MscM (mini conductance). These channels are usually closed, but can open upon changes in membrane tension to allow solute efflux (Blount and Moe 1999).

4.4. Applications of ectoines

Apart from osmotic function, ectoines have gained much attention in biotechnology as protective agents for enzymes, DNA, membranes and even entire cells against stress conditions such as heating, drying and freezing (Lippert and Galinski 1992; Louis et al. 1994; Welsh 2000).

Many publications have shown the superior ability of ectoines as protective agents for enzymes against stress conditions, thereby increasing the shelf life and activity of enzyme preparation (Andersson et al. 2000; Borges et al. 2002; Kolp et al. 2006; Lippert and Galinski 1992). For that reason they are sometimes termed “molecular chaperones”. In a study on the effect of the protective effects of various compatible solutes (glycine betaine, trehalose, maltose, sucrose, ectoine, and hydroxyectoine) on the model enzymes lactic dehydrogenase (LDH) and phosphofructokinase (PFK), the results indicated that all compatible solutes tested were able to protect the enzymes against the stresses of freezing, heating and drying (Lippert and Galinski 1992). Hydroxyectoine showed the highest efficacy for the protection of LDH against a freeze-thaw treatment and heat stress, whereas ectoine was the most effective freeze-stabilizing agent for PFK (Lippert and Galinski 1992). A comparative investigation of the thermostabilizing properties of some compatible solutes (mannosylglycerate, trehalose, ectoine, hydroxyectoine, di-*myo*-inositol phosphate, diglycerol phosphate, and mannosylglyceramide) on the model enzyme LDH showed that hydroxyectoine was the best stabilizer, whereas ectoine protected the enzyme to a lower extent (Borges et al. 2002). Ectoine and hydroxyectoine were also shown to protect the zymogens against

activation, and ectoine was the most potent solute in reducing the formation of trypsin and chymotrypsin (Kolp et al. 2006). Hydroxyectoine has been seen to be able to protect LDH from metal-catalyzed oxidation as well as from oxidation by hydrogen peroxide (Andersson et al. 2000). As described in Paper VI, ectoine and hydroxyectoine have also been shown to provide protection against pH stress. For example, the alkaline active xylanase from *Bacillus halodurans* retained a significantly higher activity in the presence of ectoine and hydroxyectoine during incubation at pH 4.5 as well as at pH 12. Furthermore, hydroxyectoine provided a higher stabilizing effect as opposed to ectoine (**Paper VI**).

Beside acting as protective agents for enzymes against stress conditions, some osmolytes can be used for PCR amplification of DNA with a high G+C content and therefore with a high melting temperature. Ectoine and betaine, for example, have been shown to decrease the melting temperature of double-stranded DNA (Lapidot et al. 1999; Schnoor et al. 2004). Ectoine and hydroxyectoine also increase the thermal stability of DNA polymerases at elevated temperatures, thereby demonstrating that they could be used to improve primer extension and polymerase chain reactions (Lapidot et al. 1999).

Ectoines do not only stabilize proteins and other macromolecules, they are also potent cell protectants. Louis et al. (1994) showed that the addition of ectoine and hydroxyectoine prior to freeze-drying increased the survival rate of the two *E. coli* strains tested. Ectoine can be used in fermentation technology to increase the osmotolerance and yield in the production of amino acids by coryneform bacteria (Yasuhiko et al. 1997). Manzanera et al. (2004) showed that *E. coli* dried in hydroxyectoine exhibited a high degree of desiccation tolerance, similar to that achieved when using trehalose as an extracellular protectant. In addition, the results obtained for the gram-negative soil bacterium *Pseudomonas putida* suggested that hydroxyectoine was superior to trehalose as a desiccation protectant, thus offering a significant potential as a drying excipient for live microorganisms (Manzanera et al. 2002).

Cytoprotection by ectoines is however not limited to bacteria: it can also be applied to eukaryotic cells. The effect of ectoine on membranes was tested with a red blood cell (RBC) assay, and the results suggested that damage of the cell membrane by surface active substances was significantly reduced or prevented by a pre-treatment with ectoine (Bünger et al. 2001). Ectoine has also been found to protect human skin against harmful ultraviolet irradiation (Bünger and Driller 2004). The introduction of ectoine or its derivatives into cosmetic preparations increases their humidifying activity and provides a stabilization of the skin (Bünger et al. 2003). For these reasons, a major application area for extremolytes established today is in cosmetics where ectoine (Ectoine™) is now used in a growing range of skin care products (Lentzen and Schwarz 2006).

5. Biotechnological production of polyhydroxyalkanoates and ectoines

5.1. Cell cultivation technologies

Both PHA and ectoines are intracellular products, and their yield is thus closely related to the biomass concentration. A high cell concentration results in an increased productivity and reduces the cost of the downstream processing. This should be considered when developing cultivation methods for the efficient production of such bioproducts. In a conventional batch cultivation, the growth of an organism becomes restricted with time due to lack of some substrate component such as oxygen or accumulation of an inhibitory metabolic product, hence resulting in low cell densities. Fed-batch cultivation and continuous cultivation are the most popular culture systems (Figure 9), and have been used in biotechnology to achieve high cell densities and high productivities (Lee 1996b).

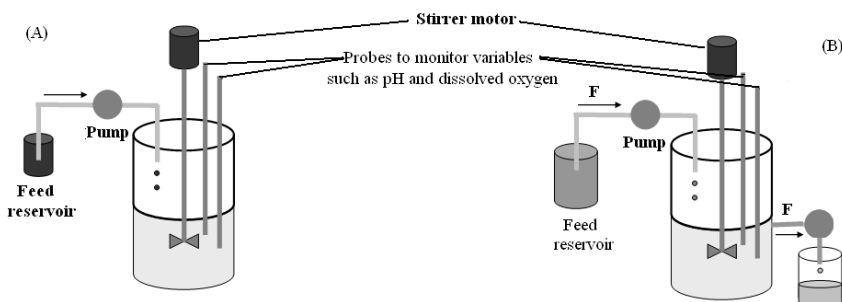

Figure 9. Diagrammatic representation of fed-batch (A) and continuous (B) cultivation

5.1.1. Fed-batch cultivation

In fed-batch cultures, a fresh medium (feed solution) is supplied either continuously or in batches to the bioreactor. The feed of the required components for growth and/or other substrates required for the accumulation of the product can never be depleted and the nutritional environment can be maintained approximately constant during the course of the batch. The feed solution is usually prepared at high concentration to avoid dilution of the production medium in the bioreactor (Figure 9) (Enfors and Haggström 2000). The fed-batch strategy is typically used in bio-industrial processes as it permits reaching a high cell density in the bioreactor.

5.1.2. Fed-batch culture with medium exchange

Fed-batch cultivation combined with medium exchange has been used for the production of ectoines (Frings et al. 1995; Krahe et al. 1996). This method helps to reduce the inhibitory effect of the metabolic by-products formed during high cell-density fermentation, resulting in elevated concentrations of both biomass and ectoines. The metabolic by-products can be partly removed from the culture broth by using cross flow filtration or centrifugation after the culture has entered the stationary phase (Frings et al. 1995). Dialysis cultivation is a superior method that can give higher biomass concentrations by continuously exchanging the nutrient broth to prevent accumulation of inhibitory substances (Krahe et al. 1996). However, dialysis cultivation is limited by its restricted scale-up capacity.

5.1.3. Continuous cultivation

A system is referred to as continuous or chemostat cultivation when the feed and product streams are continuously fed and withdrawn, respectively, from the system. Here, the influx of a sterile medium from a reservoir is balanced by the efflux of the spent medium. The advantage of this system is that the microbial population within the vessel grows at a constant rate in a constant environment and assumes a “steady state”. Environmental factors (e.g., pH, temperature), the nutrient concentration and metabolic products can be varied and controlled during the cultivation (Figure 9) (Hoskisson and Hobbs 2005).

5.2. Genetic technologies to facilitate production

5.2.1. Genetic engineering

Cloning and expression of genes in a heterologous microbial host is currently a standard practice for biotechnological production. Besides allowing much higher levels of production than in the wild type host, it provides the possibility to manipulate the gene sequence by mutagenesis (protein engineering) and to perform structure-function studies and to vary the product features. Recently, the nucleotide sequences of at least 88 polyester synthase genes and numerous genes encoding for enzymes catalyzing the formation of hydroxyacyl-coenzyme A thioesters have been obtained (Rehm 2007). Many of these genes have been successfully expressed in *E. coli* (Ahn et al. 2000; Choi et al. 1998; Kahar et al. 2005), in *Saccharomyces cerevisiae* (Leaf et al. 1996), in insect (Williams et al. 1996) and in plant cells (Hahn et al. 1997). Several quite different PHAs can be obtained from recombinant *E. coli*. They are homopolymers [PHB, P(4HB), and P(4HV)], copolymers consisting of 3HB plus 3HV, 4HB or 4HV, terpolymer

consisting of 3HB, 3HV plus 3HHx and also PHAs consisting of various 3HA_{MCL} (Ahn et al. 2000; Choi et al. 1998; Davis et al. 2008; Kahar et al. 2005; Kim et al. 1992; Park et al. 2001; Valentin and Dennis 1997; Wong and Lee 1998).

For ectoine production, the *ectABC* gene cluster involved in the ectoine biosynthesis has been isolated from many halophilic bacteria and expressed in *E. coli* (Louis and Galinski 1997; Rajan et al. 2008; Schubert et al. 2007). The recombinant *E. coli* strain is promising for large-scale production since it produces ectoine at a high rate and excretes the product into the medium (easy to separate) (Schubert et al. 2007).

5.2.2. Metabolic engineering

Metabolic engineering is a novel field and has become a new approach for the more efficient production of desired bioproducts. A whole metabolic pathway is cloned and expressed and allows directed improvement of the product formation by changing the selectivity of a pathway to favor one product and/or eliminate undesirable metabolic routes to enrich the desired product (Aldor and Keasling 2003; Steinbüchel 2001).

Recently, several strategies for the metabolic engineering of bacteria for PHA production have been proposed and applied. The simplest strategy is the addition of PHA precursor substrates to the medium under conditions permitting the synthesis and accumulation of PHA. *Cupriavidus necator* produced a copolymer of 3-hydroxybutyrate and 3-hydroxyvalerate, poly(3HB-co-3HV), when propionic acid or pentanoic acid was provided as a carbon source, in addition to glucose under nitrogen limitation (Kim et al 1994b). The second strategy is to add inhibitors to the medium. Normally, *C. necator* accumulates PHAs with only short chain length monomers (3-hydroxypropionate and 3-hydroxybutyrate). When acrylate was used to inhibit β -oxidation during growth on octanoate, this organism accumulated a copolymer containing both short (3-hydroxypropionate and 3-hydroxybutyrate) and medium (3-hydroxyhexanoate and 3-hydroxyoctanoate) chain length monomers (Green et al. 2002). Host cell genome manipulation and protein engineering of PHA biosynthetic enzymes are two other metabolic engineering strategies that can also be employed to improve PHA production (Aldor and Keasling 2003; Steinbüchel 2001). Host cell genome manipulation can eliminate competing pathways or modify native regulation for an improved function of a desirable pathway. Protein engineering can be further applied to optimize enzyme activity in order to obtain desirable polymer properties and yields (Aldor and Keasling 2003; Steinbüchel 2001).

5.3. Polyhydroxyalkanoate production

One of the major bottlenecks in the commercial application of PHAs is their high price as compared to the conventional petroleum-based plastic materials. The selection of a microorganism for the industrial production of PHA should be based on several factors including the cells' ability to utilize an inexpensive carbon source, the growth rate, the polymer synthesis rate, and the extent of polymer accumulation (Lee 1996a). An elevated productivity is one of the most important factors for the economical production of these biodegradable polymers. The carbon source should be inexpensive since it is the major contributor to the total substrate cost. The yield of PHA with respect to the carbon source should be high so as not to waste substrate for making non-PHA materials. The PHA content can be considered as a measurement of the cell's ability to accumulate PHA under a given condition, and a high PHA content is desirable for obtaining high yields and is also beneficial for the recovery process (Lee 1996b).

Recently, for an improved production of PHA, various fermentative and metabolic engineering approaches have been established in certain bacterial strains (Lee 1996b). Thus, by using different fermentation processes and/or employing recombinant *E. coli*-harboring PHA biosynthesis genes (e.g., harboring *C. necator* PHA genes), various PHAs have been produced at elevated cell densities and high contents of intracellular polymer from a range of renewable raw materials (Tokiwa and Ugwu 2007).

5.3.1 PHA production by wild type strains

Both fed-batch and continuous cultivation techniques can be used for the production of PHA with high productivity (Lee 1996b). For PHA producers belonging to the first group (bacteria requiring the limitation of an essential nutrient - **Section 3**), a two-step fed-batch cultivation method is most often used (**Papers II, III**). The first step is carried out under optimal conditions in order to achieve high cell concentrations, while in the second step, the nutrient limitation is applied so as to induce PHA synthesis. *C. necator* is the most widely studied organism for the production of PHA by a two-step fed-batch culture. It can accumulate large amounts of polymer (up to 80 % of cell dry weight) when nitrogen or phosphorus is completely depleted (Table 5) (Kahar et al. 2004; Kim et al. 1994a; Kim et al. 1994b; Kim et al. 1995). Depending on the carbon sources provided, *C. necator* can produce PHB or poly(3-hydroxybutyrate-co-3-hydroxyvalerate) [P(3HB-co-3HV)]. Maximum PHB concentrations of 121 g/L and PHB productivities of 2.42 g/L/d were obtained when *C. necator* was grown in a fed-batch culture with glucose as the carbon source under nitrogen limitation (Kim et al. 1994a). By using glucose and propionic acid as carbon sources,

P(3HB-co-3HV) was synthesized at a final concentration of 117 g/L and a final productivity of 2.55 g/L/h (Table 5) (Kim et al. 1994b). The other bacteria belonging to the first group, such as *Protomonas extorquens* and *Pseudomonas oleovorans*, also require nutrient limitation to induce PHA synthesis, however the nutrient in question does not have to be completely depleted. *P. extorquens* can accumulate 149 g/L of PHB after 170 h of cultivation when the ratio of carbon/nitrogen feeding was controlled (Suzuki et al. 1986). The limiting nutrient ammonium was applied for the production of poly(3-hydroxyhexanoate-co-3-hydroxyoctanoate) [P(3HH-co-3HO)] by *P. oleovorans*, giving a final PHA concentration of 12.1 g/L and an overall productivity of 0.25 g/L/h (Preusting 1993) (Table 5).

Table 5. PHA production in fed-batch cultivation reported for wild-type strains

Strain	PHAs	Carbon substrate	Culture time (h)	CDW (g/L)	PHA content (wt%)	PHA conc. (g/L)	PHA prod. (g/L/d)	Reference
<i>P. extorquens</i>	PHB	Methanol	170	233	64	149	0.88	Suzuki et al. 1986
<i>P. oleovorans</i>	P(3HHx-co-3HO)	n-Octane	38	37.1	33	12.1	0.32	Preusting et al. 1993
<i>C. necator</i>	PHB	Glucose	50	164	76	121	2.42	Kim et al. 1994a
<i>C. necator</i>	P(3HB-co-3HV)	Glucose + propionic acid	46	158	74	117	2.55	Kim et al 1994b
<i>C. necator</i>	PHB	Tapioca	59	106	58	61.5	1.04	Kim et al. 1995
<i>C. necator</i>	PHB	Soybean oil	96	126	76	95.8	1	Kahar et al. 2004
<i>A. latus</i>	PHB	Sucrose	18	143	50	71.5	3.97	Yamane et al. 1996
<i>A. latus</i>	PHB	Sucrose	20	112	88	98.7	4.94	Wang and Lee 1997
<i>H. boliviensis</i>	PHB	Glucose	33	44	81	35.4	1.1	Paper II
<i>H. boliviensis</i>	PHB	Glucose	40	62	68.5	42.5	1.06	Paper III

The bacteria belonging to the second group such as *Alcaligenes latus*, and *Azotobacter vinelandii*, do not require nutrient limitation or two-step fermentation for inducing PHA synthesis since they can accumulate the polymer during growth. For this group, complex substrates such as corn steep liquor, yeast extract or fish peptone can be supplemented to enhance cell growth and PHA synthesis (Lee 1996b). *A. latus* has also been well studied in this group; it grows fast and accumulates PHA up to 80 % of dry cell weight without limitation of any nutrient. A pH-stat fed-batch culture of *A. latus* on sucrose was designed by Yamane et al. (1996). In this process, high concentrations of cells (142 g/L) and PHB (68.4 g/L) were obtained in a short culture time (18 h) with an inoculum size of 13.7 g/L (Table 5). However, only a low PHB content (50 % of the cell dry weight) was found, classifying the recovery process as inefficient. To enhance the PHB

biosynthesis capacity of *A. latus*, a fed-batch culture for which a nitrogen limitation was applied on the production of PHB by *A. latus* was investigated (Wang and Lee 1997). The cells were first cultured by the DO-stat feeding strategy without applying the nitrogen limitation. Rather, the nitrogen limitation was applied when a biomass concentration of 76 g/L was reached. A maximum biomass concentration of 117 g/L, a PHB content of 88 wt%, and a PHB concentration of 98.7 g/L were obtained after 8 h of cultivation under nitrogen limitation, resulting in the high productivity of 4.94 g/L/h (Table 5).

Two strategies of continuous cultivation have been suggested for the production of PHA. For most of the bacteria belonging to the first group, a two-stage chemostat should be used. For the bacteria belonging to the second group as well as for some of those belonging to the first group, but which do not require a great change in concentration of a limiting nutrient between the growth phase and the polymer accumulation phase (c.a. *P. oleovorans*), a one-stage chemostat could be used (Lee 1996b).

One-stage chemostat was employed for the production of PHA by *P. oleovorans* and *C. necator* (Ramsay et al. 1991; Koyama and Doi 1995). Growing *P. oleovorans* in chemostat with 2 g/L of ammonium sulphate and 8 g/L of octanoate in the feed, a maximum specific growth rate of 0.51/h, and the PHA production rate of 0.074 g PHA/g of the cellular protein/h were obtained at a dilution rate (D) of 0.25/h. When the dilution rate was 0.24/h, the percentage of PHA in the biomass was relatively constant at 13 % of cell dry weight at all C/N ratios (Ramsay et al. 1991). P(3HB-co-3HV) was produced by *C. necator* in a continuous culture with 17.5 g/L of fructose and 2.5 g/L of pentanoic acid in the feed. The maximum P(3HB-co-3HV) productivity of 0.31 g/L/h was reached under nitrogen limitation at a dilution rate of 0.17/h (Koyama and Doi 1995).

Currently, two-stage chemostat is often employed for the production of PHA by *P. oleovorans* and *C. necator* (Du et al. 2001; Lee et al. 1995; Preusting et al. 1991; 1993). *P. oleovorans* was cultivated in a two-phase medium containing about 15 % (v/v) octane with nitrogen as the limiting nutrient. The biomass concentration and PHA content decreased from 2.25 and 46.7 to 1.32 mg/ml and 8.3% when the dilution rate increased from 0.09 to 0.46/h, respectively (Preusting et al. 1991). In another system, a biomass concentration of 11.6 g/L with a PHA productivity of 0.58 g/L/h was obtained by optimizing the feeding strategy and increasing the oxygen transfer rate (Preusting et al. 1993).

An optimization of the two-stage continuous culture system for PHB production by *C. necator* was investigated. When the fermentor volume ratio (V_2/V_1) was 0.5, a maximum PHB productivity of 2.86 g/L/h with a biomass concentration of 75 g/L and a PHB content of 59.8 g/L was obtained (Lee et al. 1995). A higher PHB content of 72 wt% was reached when growing *C. necator*

under nitrogen-limited conditions in the second stage at a dilution rate of 0.075/h (Du et al. 2001).

5.3.2. PHB production by *Halomonas boliviensis*

Halomonas species are able to grow over a wide range of NaCl concentrations; the optimal concentration is 4.5 % (w/v) NaCl. The moderate salt concentration required for the optimal growth of these microorganisms is enough to inhibit the growth of non-halophiles, thus rendering it possible to perform cultivations under relatively non-sterile conditions (Quillaguamán et al. 2005). Furthermore, the ability of these species to grow on different carbon sources originating from agricultural residues or by-products of the food industry is evident (**Paper I**). These substrates can potentially serve as raw materials for PHA production.

The production of PHA has been extensively studied in *H. boliviensis*. The organism only produces PHB in response to nitrogen limitation in the medium (**Paper II**). A PHB content of 50-90 wt% could be reached depending on the carbon source and the cultivation conditions used (Quillaguamán et al. 2005; Quillaguamán et al. 2006; Quillaguamán et al. 2007; **Paper I**; **Paper II**; **Paper III**). The variation in NaCl concentration in the medium was found not to have any appreciable effect on the PHB. However, at higher concentrations (10-15% w/v) the initiation of PHB synthesis was delayed and cell growth was drastically affected (Quillaguamán et al. 2006).

H. boliviensis is unable to grow with starch as the sole carbon source. However, this strain was grown and could accumulate PHB (to about 56 wt%) in a medium containing hydrolyzed starch (starch was partially hydrolyzed by a recombinant maltooligosaccharide-forming amylase from an alkaliphilic bacterium *Bacillus halodurans* LBK 34) as the carbon source and with a limited nitrogen content (Quillaguamán et al. 2005). The use of such a hydrolysate demonstrated that the organism preferentially utilized maltose for PHB accumulation. Also higher sugars can be employed if simpler carbon sources are unavailable, however this leads to a significantly lower PHB content (Quillaguamán et al. 2005). Other cheap substrate sources, such as wheat bran hydrolysate and digested potato waste, can also be utilized for PHB production by *H. boliviensis* (**Paper I**). A maximum PHB content of 50 wt% and a PHB concentration of 4 g/L were obtained after 20 h of cultivation in a batch fermentor with wheat bran hydrolysate, sodium acetate, and butyric acid. The replacement of sodium acetate and butyric acid (expensive substrates) with digested potato extract (cheap substrate) resulted in a decrease in the PHB content and concentration to 43 wt% and 2.8 g/L, respectively (**Paper I**).

The use of waste agricultural residues has been found to substantially reduce the substrate cost (and in turn, even provide value to the waste). Consequently, it becomes possible to downsize the production costs. However, the use of complex substrate sources, such as wheat bran hydrolysate, digested potato extract, and yeast extract, renders it difficult to control the supply of nutrients for achieving high cell densities as well as optimal PHB productivities. In order to improve the PHB productivity, a defined medium was designed and used for PHB production through fed-batch cultures by *H. boliviensis* (**Paper II**). During the fermentation, concentrations of certain nutrients, such as glucose, mono-sodium glutamate (MSG), and NH_4^+ , were controlled in the feed. PHB synthesis was initiated when both MSG and NH_4^+ were being depleted from the medium. A maximum PHB content of 81 wt% and a CDW of 44 g/L were reached after 33 h of cultivation (Table 5). The PHB content obtained by *H. boliviensis* was comparable to values reported for some of the known high-PHA producers so far (Table 5).

5.3.3. PHA production using recombinant *E. coli*

For an improved production of PHA, recombinant DNA techniques have been used to introduce the PHA biosynthesis genes from wild type strains into *E. coli*. Many recombinant *E. coli* strains harboring the PHA biosynthesis genes in a stable high-copy-number plasmid have been developed and were used for producing the polymer at high productivity (Ahn et al. 2000; Choi et al. 1998; Kahar et al. 2005; Kim et al. 1992; Wong and Lee 1998). A comparative evaluation of various strategies for the production of PHA has demonstrated that recombinant *E. coli* gave a higher PHA concentration and PHA productivity as opposed to wild-type strains (Table 6). For instance, recombinant *E. coli* (XLI-blue) harboring *C. necator* PHB biosynthesis genes can accumulate PHB concentrations up to 161 g/L and PHB productivities of 2.98 g/L/d in fed-batch cultures with glucose (Kahar et al. 2005). A highest PHB productivity of 4.63 g/L/d with a PHB concentration of 142 g/L was achieved by another recombinant *E. coli* (XLI-blue) harboring the *A. latus* PHB biosynthesis genes (Choi et al. 1998).

The analysis and economic evaluation of the process for the production of PHA suggested that the cost of the substrate (mainly the carbon source) contributed most significantly (up to 50%) to the overall production cost (Choi and Lee 1999). The use of recombinant *E. coli* as the PHA producer can also help to reduce the PHA production cost since *E. coli* can utilize a wide range of carbon sources, including lactose, xylose, sucrose, and cheap agricultural waste or byproducts such as whey, hemicellulose hydrolysate, and molasses (Lee 1996b). The cultivation of recombinant *E. coli* harboring a plasmid containing the PHB biosynthesis genes and using whey as the substrate resulted in a PHB content as

high as 80 % of the cell dry weight and a PHB productivity of 2.57 g/L/h (Ahn et al. 2000; Wong and Lee 1998) (Table 6).

Besides the possibility of growth on a wide range of inexpensive renewable raw materials, the use of recombinant *E. coli* as a PHA producer provides other advantages. It is easier and less costly to purify polymers from recombinant *E. coli* as opposed to from wild-type strains due to *E. coli* cells accumulating a large amount of polymer (up to 90 % of the cell dry weight), and thus becoming extremely fragile. Moreover, PHAs synthesized in *E. coli* are not degraded during fermentation due to the lack of intracellular depolymerases. Finally, *E. coli* can produce high cell densities in shorter times, which can also help to reduce the production cost of PHA.

Table 6. PHB production in fed-batch cultivation reported for recombinant *E. coli*

Recombinant strain	PHB biosynthesis genes from	Carbon substrate	Culture time (h)	CDW (g/L)	PHB content (wt%)	PHB conc. (g/L)	PHB prod. (g/L/d)	Reference
<i>E. coli</i> (XL1-Blue)	<i>C. necator</i>	Glucose	42	117	76	88.8	2.12	Kim et al. 1992
<i>E. coli</i> (XL1-Blue)	<i>A. latus</i>	Glucose	31	194	73	142	4.63	Choi et al. 1998
<i>E. coli</i> (GCSC 7576)	<i>C. necator</i>	Whey	49	87	80	69	1.42	Wong and Lee 1998
<i>E. coli</i> (CGSC 4401)	<i>A. latus</i>	Whey	37.5	119.5	81	96.8	2.57	Ahn et al. 2000
<i>E. coli</i> (XL1-Blue)	<i>C. necator</i>	Glucose	54	201	80	161	2.98	Kahar et al. 2005

5.4. Ectoine production

The first biotechnological process for producing ectoines, termed “bacterial milking”, was designed by Sauer and Galinski (1998). It involved the use of a moderately halophilic bacterium *Halomonas elongata*. In this process, *H. elongata* was first grown by fed-batch cultivation at a high salt concentration [15 % (w/v) NaCl] to induce the accumulation of ectoine. After a high cell density fermentation (to obtain about 48 g/L cell dry weight), bacterial cells were concentrated using crossflow filtration. When transferred to a medium of low salinity [hypo-osmotic shock from 15 % to 3 % (w/v) NaCl], the cells rapidly released their accumulated solutes to achieve osmotic equilibrium. The product solution was separated from the cells by applying a second crossflow filtration, and further purification by chromatography, filtration, evaporation, and crystallization was carried out on the excreted ectoine. The biomass was returned to the medium with its original salinity (hyper-osmotic upshock, back to 15 % NaCl), which led to a renewed synthesis of osmotic solutes (Figure 10). After a generation time of 1 day, this procedure could be repeated, and following nine cycles, an average of about 155 mg ectoine/g cell dry weight per cycle was produced.

Another ectoine bioprocess, with an even higher productivity, was recently developed by Lentzen and Schwarz, based on the continuous fermentation of *H. elongata*. This continuous “permanent milking” process is now used by bitop AG for the production of ectoines in metric ton scale (Lentzen and Schwarz 2006). In this process, *H. elongata* is cultivated in a continuous fermentation and the culture broth is separated from the biomass by microfiltration. The concentrated biomass is exposed to an osmotic downshock and again concentrated by microfiltration. The solution containing excreted ectoine is the starting material for the purification process consisting of the following key steps: electro dialysis, chromatography, and crystallization (Figure 11).

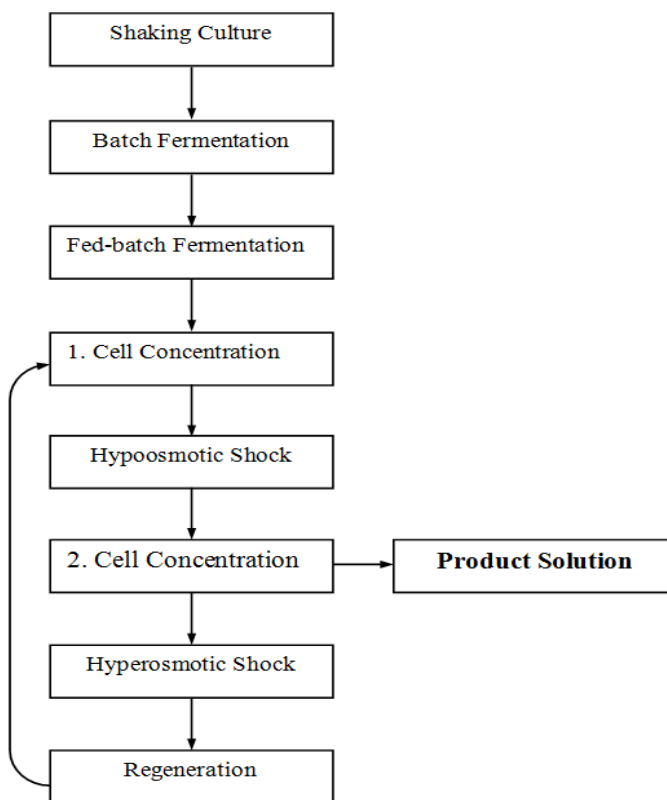

Figure 10. The process diagram for “bacterial milking” (Sauer and Galinski 1998)

For the production of hydroxyectoine, a bioprocess using the *Marinococcus* strain M52 was designed by Frings and coworkers (Frings et al. 1995). An exponential fed-batch strategy with medium exchange was applied for the cultivation of *Marinococcus* strain. The application of this technique is one of the most promising methods for increasing final cell densities, due to its effect on

reducing the inhibitory effect of metabolic by-products on the growth of *Marinococcus*. A maximum cell dry weight concentration of 56 g/L and a hydroxyectoine content of 13.5 wt% were obtained after approximately 120 h of cultivation. Hydroxyectoine was extracted from the washed and “desalted” cell material by Soxhlet extraction with methanol.

Hydroxyectoine has also been produced by *H. elongata* by changing the fermentation conditions in the bacterial milking process. The relative proportion of ectoine and hydroxyectoine in *H. elongata* depended on the salinity and temperature of the medium (Sauer and Galinski 1998). At salinities up to 15% (w/v) NaCl and temperatures below 25 °C, only ectoine was produced. However, the hydroxyectoine content increased with higher salinities and temperatures. The relative proportion of hydroxyectoine could reach 50 % when *H. elongata* was grown at 20 % (w/v) NaCl and 40 °C.

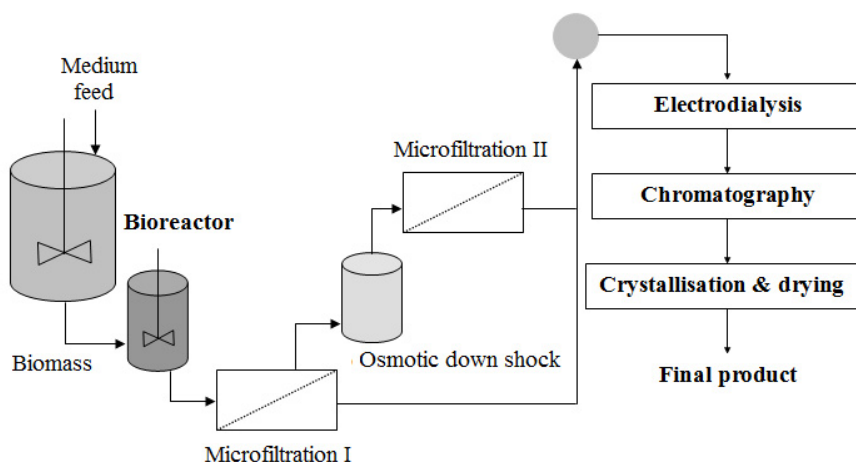

Figure 11. A process diagram for “permanent milking” (Modified from Lentzen and Schwarz 2006)

5.4.1. Ectoines production by *H. boliviensis*

In order to adapt to the high salt concentration in the surrounding medium, *H. boliviensis* accumulates compatible solutes - ectoines (ectoine and hydroxyectoine). Similarly to other halophilic microorganisms, the accumulation of ectoines by *H. boliviensis* is strictly dependant on the salt concentration in the surrounding medium (**Paper III**). Only ectoine has been detected at lower salt concentration (5-7.5 % NaCl) and was found to increase for an increasing salt concentration. Over a range of higher salt concentrations (10-15 % w/v), the presence of hydroxyectoine has also been seen. A two-step process for the co-

production of ectoine and poly(3-hydroxybutyrate) has been designed. A maximum biomass concentration of 62 g/L, an ectoine content of 7-14 wt%, and a volumetric productivity of 2.8 g/L/d have been obtained after 40 h of cultivation (**Paper III**).

In order to improve the ectoine yield, a central composite experimental design was applied to optimize media constituents for biomass and ectoine production (**Paper IV**). The optimized conditions were then used for two-step fed-batch cultivation (Figure 12). A maximum biomass and ectoine concentration of 63 g/L and 9.2 g/L, respectively, were obtained, resulting in a high ectoine productivity of 6.3 g/L/h (**Paper IV**).

Two-step fed-batch cultivations were also employed for the co-production of ectoine and hydroxyectoine (Figure 12). By increasing the NaCl concentration to 18.5% (w/v) in the second step, the ectoine content increased and reached a maximum value of 27.8 wt% with the relative proportion of hydroxyectoine of 57%. The productivity of ectoines was also increased to 10 g/L/d with an ectoine concentration of 6 g/L and a hydroxyectoine concentration of 8 g/L after 9 h of cultivation. These concentrations of the ectoines are among the highest reported so far. “Bacterial milking” process for the production of ectoines *H. boliviensis* was also investigated. The cells rapidly released their solutes when subjected to a hypoosmotic solution containing 1.5% (w/v) NaCl; about 75% of the total ectoines was released after 30 minutes of permeabilization. Subsequent reincubation in a hyperosmotic medium containing 15% (w/v) NaCl the cells were able to resynthesize the compatible solutes, and the procedure could be repeated after 12 h (**Paper V**).

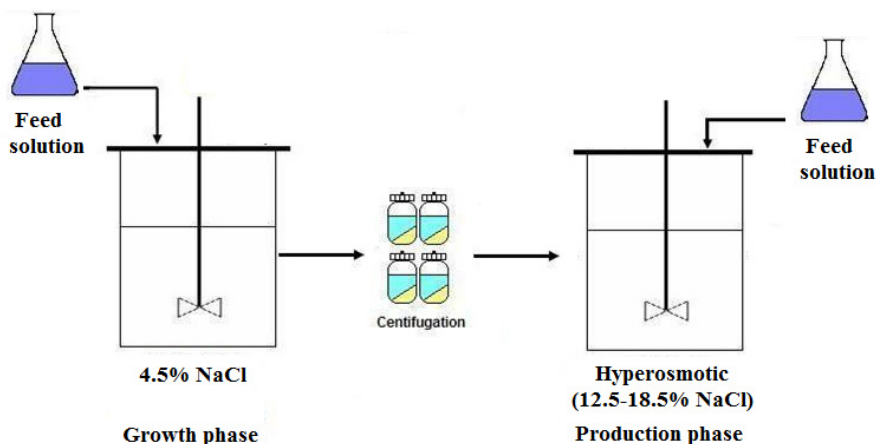

Figure 12. A two-step fed-batch system for the production of ectoines by *H. boliviensis*

5.5. Co-production of PHA and ectoines

Many halophilic strains have been found to accumulate both PHA and compatible solutes. A halophilic phototrophic bacterium *Ectothiorhodospira halochloris*, isolated from an extremely saline and alkaline soda lake in Egypt, can accumulate betaine, ectoine and trehalose as compatible solutes. PHB was also synthesized and reached a maximum value of 70 mg/L wet weight (about 9 % of cell dry weight) (Galinski and Herzog 1990). Two moderately halophilic facultatively methylotrophic bacteria, isolated from coastal saline habitats, i.e., *Methyloarcula marina* and *Methyloarcula terricola*, can also intracellularly accumulate PHB and the compatible solutes (ectoine and glutamate). Ectoine was the major cytosolic constituent (concentration of 18 % cell dry weight at 6-10 % NaCl), whereas glutamate was a minor one (Doronina et al. 2000). Some halophilic bacteria belonging to the *Halomonas* genus were also reported to produce PHA and compatible solutes (mainly ectoine). For instance, two alkaliphilic Gram-negative bacteria were isolated from Campania (Italy), *Halomonas campaniensis* (strain 5AG^T) and *Halomonas alkaliphila* (strain 18bAG^T) (Romano et al. 2005; 2006). *Halomonas campaniensis* can accumulate PHB of about 0.11 to 12.4 % (w/w) of the cell wet weight and varying compatible solute contents from 0.007 (mmol/g of wet cells) up to 0.72 depending on the growth conditions (Strazzullo et al. 2008).

Co-production of ectoines and PHB was achieved by *Halomonas elongata* in a fed-batch culture using a medium containing 10 % (w/v) NaCl and N-limited or P-limited conditions (Mothes et al. 2008). This work led to the observation that the intracellular ectoine content remained approximately constant when the deficiency of P-source limited the *H. elongata* growth. However, it decreased slightly when the depletion of the N-source restricted the cellular growth (Mothes et al. 2008). After N-source exhaustion, the PHB yield by *H. elongata* reached a maximum of 55 % (w/v) within 120 h, whereas the ectoine content was about 6 % of the cell dry mass. The maximum ectoine content (ca 12.5 %) was reached after 45 hours of growth. *Halomonas halodenitrificans*, *Halomonas haloneurihalina*, and *Halomonas salina* exhibited similar behaviors when grown under these conditions, producing 40 wt% PHB and 8-12 % ectoine. An optimized process for the coproduction of ectoine and PHB by *H. elongata* is currently under investigation (Mothes et al. 2008).

The possibility of co-production of PHB and ectoine by *H. boliviensis* has been explored (**Paper III**). A two-step fed-batch system was designed. During the first step, *H. boliviensis* was grown under optimal conditions in order to achieve a high cell mass. The bacterial cells were then grown in a second fed-batch system containing a higher salt concentration [e.g., 7.5 % (w/v) NaCl]. In this step,

nutrients (NH_4Cl , K_2HPO_4 and sodium glutamate) were first fed to allow cell growth and synthesis of ectoines, and the addition of the nitrogen sources was subsequently suspended to induce PHB accumulation. This process resulted in an ectoine content of 13.2 % and a volumetric productivity of 4 g/L/d after an overall production time of 22 h. This was reduced to a content of 6.1 wt% and a productivity of 2.8 g/L/d after 40 h when a maximum PHB accumulation of 68.5 wt% and a productivity of 1.06 g/L/h were reached. These results were similar to those found during the production of PHB alone by *H. boliviensis* (Table 5) (**Paper III**).

6. Concluding remarks and future perspectives

The work done in this thesis builds on the ability of a salt-loving organism isolated from nature to accumulate two classes of products – biodegradable plastic formed as an energy reserve, and compatible solutes formed to counter the effects of high salinity in the environment.

The first part of the thesis has dealt with various solutions for reducing the cost of PHB production by *Halomonas boliviensis*: the use of cheap substrate sources, improvement of the fermentation process, and the co-production of PHB and ectoine. The results demonstrate that *H. boliviensis* can accumulate high PHB contents from cheap and readily available agricultural residues such as wheat bran hydrolysate and anaerobic digestion of solid potato waste. Moreover, the results also indicated that a suitable energy balance for PHB accumulation could be achieved by using adequate ratios of different carbon sources, from cheap chemical or agricultural remnants.

Developing new culture media and cultivation strategies with the aim of achieving high volumetric productivities is the second solution to reduce the PHB production cost. A defined medium using monosodium glutamate and NH_4Cl as nitrogen sources and the optimization of PHB production through fed-batch fermentations were investigated. A high cell density was obtained by means of off-line analysis and addition of the feed solution at an early stage. The PHB accumulation was then promoted by depleting the nitrogen sources. The volumetric productivity and PHB yield obtained by *H. boliviensis* were improved and were found to be comparable to the highest values reported thus far. There is however further scope for improvement.

The co-production of PHB and ectoine by *H. boliviensis* is another potential solution for reducing the production cost. A two-step fed-batch system was designed; cells were first grown under optimal conditions so as to achieve high cell mass values, after which they were transferred to a second medium containing high salt concentrations and with a limitation of an essential nutrient (nitrogen) to permit an efficient PHB and ectoine synthesis. However, PHB has a potential to be a large volume-low cost product in contrast to ectoines that are low volume-high cost products, and co-production may not be a general solution.

The second part of this thesis was focused on improving ectoine production by *H. boliviensis* and investigating the ability of ectoines as protective agents for enzymes against pH stress. Under optimal conditions, a maximum ectoine content of 27.8 wt% and an ectoine productivity of 10 g/L/d were obtained, which are among the highest reported so far. The results show the market competitiveness and place this organism as a new and attractive option for the production of ectoines. It was further demonstrated that using ectoine and hydroxyectoine as additives can help to significantly improve the enzyme stability under alkaline and acidic conditions.

With the increasing demand for bioplastics in future as a replacement for fossil based plastics, there is need to make the processes more cost-effective. On the other hand, ectoines are likely to find increasing use as additives in biotech products such as biopharmaceuticals and in cosmetic preparations. The use of varying carbon sources as well as the online monitoring and control of nutrient sources during the fermentation process is an option for future work on improving PHB and ectoine production by *H. boliviensis*. Another alternative consists in the isolation and expression of the ectoine and PHB synthesis genes in new host cells.

Acknowledgements

I would like to express my sincere gratitude to all of you, who, in one way or another, have supported me during my PhD studies.

My supervisors:

Professor Rajni Hatti-Kaul, for your guidance, dedication, patience, motivation and support throughout my work. Thank you for all that you have done for me!

Professor Bo Mattiasson, for accepting me as a PhD student at the department, for your guidance, support and encouragement.

Dr. Jorge Quillaguamán, for your friendship, guidance, help and for all exciting discussions.

My teacher in Vietnam, Dr. Mai Thi Hang, for your confidence, for your support throughout my undergraduate and postgraduate training.

My co-authors, with whom it has been a great pleasure working:

Dr. Gashaw Mamo, for your guidance, support and scientific advice.

Hector Guzmán, for your friendship, support and encouragement.

Javier Martin, for your friendship and enthusiasm.

The department's two wonderful secretaries, Siv and Kersti, for your kindness, patience and unreserved help since the first day I arrived in Lund.

Frans-Peder Nilson, for your help with computer-related problems and interesting discussions.

The members at the Department of Biotechnology, and in particular the DSP group, for making the past 4 years enjoyable, for the good work environment, and for all the fun moments we have had in the lab, during fikas, parties and traveling. Special thanks to Thuy, Daniel, Marlene, Suhaila, Victor, Deepti, Georgina, Laura, Tarek, Ravi, and Cecilia.

My Vietnamese friends in Lund, for helping me, and for encouraging me during difficult moments. Special thanks to Thuy, Hoan, Nam, Tu, Toan, Hoa, Tinh, Tuyet, and Nhi.

My family, con cảm ơn bố mẹ, các anh chị, mẹ Giá và bà đã yêu thương và giúp đỡ chúng con.

My wife Dinh, for your patience, love, understanding and continuous encouragement. My daughter Thien Huong, “Con chính là nguồn động lực để bố đã và sẽ tiếp tục phấn đấu đẩy con gái yêu ạ”.

The Swedish International Development Agency (Sida) for financial support, and for giving me the opportunity to do my PhD both in Sweden and in Vietnam.

References

- Ahn WS, Park SJ, Lee SY (2000) Production of poly(3-hydroxybutyrate) by fed-batch culture of recombinant *Escherichia coli* with a highly concentrated whey solution. *Appl Environ Microbiol* 66:3624-3627
- Aldor IS, Keasling JD (2003) Process design for microbial plastic factories: metabolic engineering of polyhydroxyalkanoates. *Curr Opin Biotechnol* 14:475-483
- Anderson AJ, Dawes EA (1990) Occurrence, metabolism, metabolic role, and industrial uses of bacterial polyhydroxyalkanoates. *Microbiol Rev* 54:450-472
- Anderson MM, Breccia JD, Hatti-Kaul R (2000) Stabilizing effect of chemical additives against oxidation of lactate dehydrogenase. *Biotechnol Appl Biochem* 32:145-153
- Antunes A, Taborda M, Huber R, Moissl C, Nobre MF, da Costa MS (2008) *Halorhabdus tiamatea* sp. nov., a non-pigmented extremely halophilic archaeon from deep-sea, hypersaline anoxic basin of the Red Sea, and emended description of the genus *Halorhabdus*. *Int J Syst Evol Microbiol* 58:215-220
- Araki A, Yamaguchi N, Hayashi H, Nakadai T, Yuasa K (1997) Production of soy sauce. Patent JP9056360. 1997 March 4
- Azachi M, Oren A, Gurevich P, Sarig S, Henis Y (1995) Transformation of formaldehyde by a *Halomonas* sp. *Can J Microbiol* 41:548-553
- Bagai R, Madamwar D (1997) Continuous production of halophilic α -amylase through whole-cell immobilization of *Halobacterium salinarium*. *Appl Biochem Biotechnol* 621:213-218
- Banki MR, Gerngross TU, Wood DW (2005) Novel and economical purification of recombinant proteins: Intein-mediated protein purification using in vivo polyhydroxybutyrate (PHB) matrix association. *Protein Sci* 14:1387-1395
- Bejar V, Llamas I, Calvo C, Quesada E (1998) Characterization of exopolysaccharides produced by 19 halophilic strains of the species *Halomonas eurihalina*. *J Biotechnol* 61:135-141
- Ben-Amotz A, Avron M (1973) The role of glycerol in the osmotic regulation of the halophilic alga *Dunaliella parva*. *Plant Physiol* 51:875-878
- Bertrand JC, Almallah M, Acquaviva M, Mille G (1990) Biodegradation of hydrocarbons by an extremely halophilic archaeobacterium. *Lett Appl Microbiol* 11:260-263
- Bertrand JL, Ramsay BA, Ramsay JA, Chavarie C (1990) Biosynthesis of poly- β -hydroxyalkanoates from pentoses by *Pseudomonas pseudoflava*. *Appl Environ Microbiol* 56:3133-3138
- Berrier C, Besnard M, Ajouz B, Coulombe A, Ghazi A (1996) Multiple mechanosensitive ion channels from *Escherichia coli*, activated at different thresholds and applied pressure. *J Membr Biol* 151:175-187

- Biwas A, Patra A, Paul AK (2009) Production of poly-3-hydroxyalkanoic acids by a moderate halophilic bacterium *Halomonas marina* HMA 103 isolated from solar saltern of Orissa, India. *Acta Microbiol Immunol Hung* 56:125-143
- Blount P, Moe PC (1999) Bacterial mechanosensitive channels: integrating physiology, structure and function. *Trends Microbiol* 7:420-424
- Blount P, Schroeder MJ, Kung C (1997) Mutations in a bacterial mechanosensitive channel change the cellular response to osmotic stress. *J Biol Chem.* 272:32150-32157
- Borges N, Ramos A, Raven NDH, Sharp RJ, Santos H (2002) Comparative study of the thermostabilizing properties of mannosylglycerate and other compatible solutes on model enzymes. *Extremophiles* 6:209-216
- Borowitzka MA (1986) Micro-algae as sources of fine chemicals. *Microbiol Sci* 3:372-375
- Bouchotroch S, Quesada E, Izquierdo I, Rodríguez M, Béjar V (2000) Bacterial exopolysaccharides by newly discovered bacteria belonging to the genus *Halomonas*, isolated from hypersaline habitats in Morocco. *J Ind Microbiol Biotechnol* 24:374-378
- Bremer E, Krämer R (2000) Coping with osmotic challenges: osmoregulation through accumulation and release of compatible solutes in bacteria. In: Storz G, Hengge-Aronis R (eds) *Bacteria Stress Responses*. ASM Press. Washington, DC. pp 79-97
- Brown AD (1990) *Microbial water stress physiology. Principles and perspectives*. John Wiley & Sons, Chichester.
- Brown AD, Simpson JR (1972) Water relations of sugar-tolerant yeasts: the role of intracellular polyols. *J Gen Microbiol* 72:589-591
- Buchalo AS, Nevo E, Wasser SP, Oren A, Molitoris HP (1998) Fungal life in the extremely hypersaline water of the Dead Sea: first records. *Proc R Soc Lond B* 265:1461-1465
- Bünger J, Degwert J, Driller H (2001) The protective function of compatible solute ectoine on the skin cells and its biomolecules with respect to UV-radiation, immunosuppression and membrane damage. *IFSCC Mag* 4:1-6
- Bünger J, Driller H (2004) Ectoine: an effective natural substance to prevent UVA-induced premature photoaging. *Skin Pharmacol Physiol* 17:232-237
- Bünger J, Driller H, Martin R (2003) Use of ectoine or ectoine derivatives in cosmetic formulations. US Patent 6602514. 2003 August 5
- Burns DG, Janssen PH, Itoh T, Kamekura M, Li Zhuo, Jensen G, Rodríguez-Valera F, Bolhuis H, Dyall-Smith ML (2007) *Haloquadratum walsby* gen. nov., sp. nov., the square haloarchaeon of Walsby, isolated from saltern crystallizers in Australia and Spain. *Int J Syst Evol Microbiol* 57:387-392
- Cánovas D, Borges N, Vargas C, Ventosa A, Nieto JJ, Santos H (1999) Role of *N* γ -acetyldiaminobutyrate as an enzyme stabilizer and an intermediate in the biosynthesis of hydroxyectoine. *Appl Environ Microbiol* 65:3774-3779

- Cánovas D, Vargas C, Iglesias-Guerra F, Csonka LN, Rhodes D, Ventosa A, Nieto JJ (1997) Isolation and characterization of salt-sensitive mutants of the moderate halophile *Halomonas elongata* and cloning of the ectoine synthesis genes. *J Biol Chem* 272: 25794-25801
- Chaga G, Porath J, Illíni T (1993) Isolation and purification of amyloglucosidase from *Halobacterium sodomense*. *Biomed Chromatogr* 7:256-261
- Choi JI, Lee SY, Han K (1998) Cloning of the *Alcaligenes latus* polyhydroxyalkanoate biosynthesis genes and the use of these genes for enhanced production of poly(3-hydroxybutyrate) in *Escherichia coli*. *Appl Environ Microbiol* 64:4897-4903
- Choi J, Lee SY (1999) Factors affecting the economics of polyhydroxyalkanoate production by bacterial fermentation. *Appl Microbiol Biotechnol* 51:13-21
- Davis R, Anilkumar PK, Chandrashekar A, Shamala TR (2008) Biosynthesis of polyhydroxyalkanoates co-polymer in *E. coli* using genes from *Pseudomonas* and *Bacillus*. *Antonie van Leeuwenhoek* 94:207-216
- Degani H, Sussman I, Peschek GA, Avron M (1985) ¹³C- and ¹H-NMR studies of osmoregulation in *Dunaliella*. *Biochim Biophys Acta* 846:313-323
- Doi Y (1997) Polyhydroxyalkanoates. In: Domb AJ, Kost J, Wiseman DM (eds) *Handbook of Biodegradable Polymers*. Harwood Academic Publishers, Amsterdam. pp 79-86
- Don TM, Chen CW, Chan TH (2006) Preparation and characterization of poly(hydroxyalkanoate) from the fermentation of *Haloferax mediterranei*. *J Biomater Sci Polymer Edn* 17:1425-1438
- Doronia NV, Trotsenko YA, Tourova TP (2000) *Methyloarcula marine* gen. nov., sp. nov. and *Methyloarcula terricola* sp. nov.: novel aerobic, moderately halophilic, facultatively methylotrophic bacteria from coastal saline environments. *Int J Syst Evol Microbiol* 50:1849-1859
- Du G, Chen J, Yu J, Lun S (2001) Continuous production of poly-3-hydroxybutyrate by *Ralstonia eutropha* in a two-stage culture system. *J Biotechnol* 88:59-65
- Eisenberg H, Wachtel EJ (1987) Structural studies of halophilic proteins, ribosomes, and organelles of bacteria adapted to extreme salt concentrations. *Ann Rev Biophys Biophys Chem* 16:69-92
- Enfors S-O, Häggström L (2000) *Bioprocess Technology Fundamentals and Applications*. Royal Institute of Technology, Stockholm. pp 105-155
- Eugster HP (1980) Lake Magadi, Kenya, and its Pleistocene precursors. In: Nissenbaum A (ed) *Hypersaline Brines and Evaporitic Environments*. Elsevier, Amsterdam, pp 195-232
- Fernandez-Castillo R, Rodriguez-Valera F, Gonzalez-Ramos J, Ruiz-Berraquero F (1986) Accumulation of poly(β -hydroxybutyrate) by halobacteria. *Appl Environ Microbiol* 51:214-216

- Frings E, Sauer T, Galinski EA (1995) Production of hydroxyectoine: high cell-density cultivation and osmotic downshock of *Marinococcus* strain M52. *J Biotechnol* 43:53-61
- Galinski EA (1993) Compatible solutes of halophilic eubacteria: molecular principles, water-solute interactions, stress protection. *Experientia* 49:487-496
- Galinski EA (1995) Osmoadaptation in bacteria. *Adv Microb Physiol* 37:273-328
- Galinski EA, Herzog RM (1990) The role of trehalose as a substitute for nitrogen-containing compatible solutes (*Ectothiorhodospira halochloris*). *Arch Microbiol* 153:607-613
- Galinski EA, Louis P (1999) Compatible solute: ectoine production and gene expression. In: Oren A (ed) *Microbiology and Biogeochemistry of Hypersaline Environments*. CRC Press, Boca Raton. pp 187-202
- Galinski EA, Pfeiffer HP, Trüper HG (1985) 1,4,5,6-Tetrahydro-2-methyl-4-pyrimidinecarboxylic acid. A novel cyclic amino acid from halophilic phototrophic bacteria of the genus *Ectothiorhodospira*. *Eur J Biochem* 149:135-139
- García-Estapa R, Argandoña M, Reina-Bueno M, Capote N, Iglesias-Guerra F, Nieto JJ, Vargas C (2006) The ectD gene, which is involved in the synthesis of the compatible solute hydroxyectoine, is essential for thermoprotection of the halophilic bacterium *Chromohalobacter salexigens*. *J Bacteriol* 188:3774-3784
- Gauthier MJ, Lafay B, Christen R, Fernandez L, Acquaviva M, Bonin P, Bertrand JC (1992) *Marinobacter hydrocarbonclasticus* gen. nov., sp. nov., a new, extremely halotolerant, hydrocarbon-degrading marine bacterium. *Int J Syst Bacteriol* 42:568-576
- Gibbons NE (1974) Family V. *Halobacteriaceae*. In: Buchanan RE, Gibbons NE (eds) *Bergey's Manual of Determinative Bacteriology*. Baltimore: Williams & Wilkins. pp 269-273
- Gilmour D (1990) Halotolerant and halophilic microorganisms. In: Edwards C (ed) *Microbiology of Extreme Environments*. McGraw Hill Publishing Co, New York. pp 147-177
- Glaasker E, Konings WN, Poolman B (1996) Osmotic regulation of intracellular solute pools in *Lactobacillus plantarum*. *J Bacteriol* 178:575-582
- Gochnauer MB, Kushner DJ (1971) Potassium binding, growth, and survival of an extremely halophilic bacterium. *Can J Microbiol* 17:17-23
- Göller K, Ofer A, Galinski EA (1998) Construction and characterization of a NaCl-sensitive mutant of *Halomonas elongata* impaired in ectoine biosynthesis. *FEMS Microbiol Lett* 161:293-300
- Grammann K, Volke A, Kunte HJ (2002) New type of osmoregulated solute transporter identified in halophilic members of the bacteria domain: TRAP transporter TeaABC mediates uptake of ectoine and hydroxyectoine in *Halomonas elongata* DSM 2581^T. *J Bacteriol* 184:3078-3085

- Grage K, Jahns AC, Parlane N, Palanisamy R, Rasiah IA, Atwood JA, Rehm BHA (2009) Bacterial polyhydroxyalkanoate granules: biogenesis, structure, and potential use as nano-/micro-beads in biotechnological and biomedical applications. *Biomacromolecules* 10:660-669
- Grant WD, Gemmell RT, McGenity TJ (1998) Halophiles. In:Horikoshi K, Grant WD (eds) *Extremophiles: Microbial Life in Extreme Environments*. Wiley-Liss, Inc. pp 93-132
- Grant WD, Tindall BJ (1986) The alkaline saline environment. In:Herbert RA, Codd GA (eds) *Microbes in Extreme Environments*. Academic Press, London. pp 25-54
- Grant WD, Mwatha AA, Jones BE (1990) Alkaliphiles: ecology, diversity and applications. *FEMS Microbiol Rev* 75:255-270
- Green PR, Kemper J, Schechtman L, Guo L, Satkowski M, Fiedler S, Steinbüchel A, Rehm BHA (2002) Formation of short chain length/medium chain length polyhydroxyalkanoate copolymers by fatty acid β -oxidation inhibited *Ralstonia eutropha*. *Biomacromolecules* 3:298-213
- Gunde-Cimerman N, Butinar L, Sonjak S, Turk M, Uršič V, Zalar P, Plemenitaš A (2005) Halotolerant and halophilic fungi from coastal environments in the arctics. In:Gunde-Cimerman N, Oren A, Plemenitaš A (eds) *Adaptation of Life at High Salt Concentrations in Archaea, Bacteria, and Eukarya*. Springer, Dordrecht. pp 397-423
- Gunde-Cimerman N, Zalar P, de Hoog S, Plemenitas A (2000) Hypersaline waters in salterns – natural ecological niches for halophilic black yeasts. *FEMS Microbiol Ecol* 32:235-240
- Hahn JJ, Eschenlauer AC, Narrol MH, Somers DA, Srienc F (1997) Growth kinetics, nutrient uptake, and expression of the *Alcaligenes eutrophus* poly(β -hydroxybutyrate) synthesis pathway in transgenic maize cell suspension cultures. *Biotechnol Prog* 13:347-354
- Halami PM (2008) Production of polyhydroxyalkanoate from starch by the native isolate *Bacillus cereus* CFR06. *World J Microbiol Biotechnol* 24:805-812
- Hezayen FF, Rehm BHA, Eberhardt R, Steinbüchel A (2000) Polymer production by two newly isolated extremely halophilic archaea: application of a novel corrosion-resistant bioreactor. *Appl Microbiol Biotechnol* 54:319-325
- Hinteregger C, Streichsbier F (1997) *Halomonas* sp., a moderately halophilic strain, for biotreatment of saline phenolic waste-water. *Biotechnol Lett* 19:1099-1102
- Hoskisson PA, Hobbs G (2005) Continuous culture – making a comeback? *Micobiology* 151:3153-3159
- Hurlbert SH, Chang CCY (1984) Ancient ice islands in salt lakes of the Central Andes. *Science* 224:299-302

- Imhoff JF, Sahl HG, Soliman GSH, Trüper HG (1979) The Wadi Natrun: chemical composition and microbial mass developments in alkaline brines of eutrophic desert lakes. *Geomicrobiol J* 1:219-234
- Inbar L, Lapidot A (1988) The structure and biosynthesis of new tetrahydropyrimidine derivatives in actinomycin D producer *Streptomyces parvulus*. *J Biol Chem* 263:16014-16022
- Ishizaki A, Tanaka K, Taga N (2001) Microbial production of poly-D-3-hydroxybutyrate from CO₂. *Appl Microbiol Biotechnol* 57:6-12
- Javor BJ (2002) Industrial microbiology of solar salt production. *J Ind Microbiol Biotechnol* 28:42-47
- Jakher GR, Bhargava SC, Sinha RK (1990) Comparative limnology of Sambhar and Didwana lakes (Rajasthan, NW India). *Hydrobiologia* 197:245-256
- Jebbar M, Sohn-Bösser L, Bremer E, Bernard T, Blanco C (2005) Ectoine-induced proteins in *Sinorhizobium meliloti* include an ectoine ABC-type transporter involved in osmoprotection and ectoine catabolism. *J Bacteriol* 187:1293-1304
- Kahar P, Agus J, Kikkawa Y, Taguchi K, Doi Y, Tsuge T (2005) Effective production and kinetic characterization of ultra-high-molecular-weight poly[(R)-3-hydroxybutyrate] in recombinant *Escherichia coli*. *Polym Degrad Stabil* 87:161-169
- Kahar P, Tsuge T, Taguchi K, Doi Y (2004) High yield production of polyhydroxyalkanoates from soybean oil by *Ralstonia eutropha* and its recombinant strain. *Polym Degrad Stabil* 83:79-86
- Kamekura M (1986) Production and function of enzymes from eubacterial halophiles. *FEMS Microbiol Rev* 39:145-150
- Kempf B, Bremer E (1998) Uptake and synthesis of compatible solutes as microbial stress responses to high-osmolality environments. *Arch Microbiol* 170:319-330
- Khanna S, Srivastava AK (2005) Recent advances in microbial polyhydroxyalkanoates. *Process Biochem* 40:607-619
- Kim BS, Lee SC, Lee SY, Chang HN, Chang YK, Woo SI (1994a) Production of poly(3-hydroxybutyric acid) by fed-batch culture of *Alcaligenes eutrophus* with glucose concentration control. *Biotechnol Bioeng* 43:892-898
- Kim BS, Lee SC, Lee SY, Chang HN, Chang YK, Woo SI (1994b) Production of poly(3-hydroxybutyric-co-hydroxyvaleric acid) by fed-batch culture of *Alcaligenes eutrophus* with substrate control using on-line glucose analyzer. *Enzyme Microb Technol* 16:556-561
- Kim BS, Lee SY, Chang HN (1992) Production of poly- β -hydroxybutyrate by fed-batch culture of recombinant *Escherichia coli*. *Biotechnol Lett* 14:811-816
- Kim BS, Lee SY, Chang HN (1995) Control of glucose feeding using exit gas data and its application to the production of PHB from tapioca hydrolysate by *Alcaligenes eutrophus*. *Biotechnol Tech* 9:311-314

- Kirk RG, Ginzburg M (1972) Ultrastructure of two species of halobacterium. *J Ultrastr Res* 41:80-94
- Kis-Papo T, Oren A, Wasser SP, Nevo E (2003) Survival of filamentous fungi in hypersaline Dead Sea water. *Microb Ecol* 45:183-190
- Krahe M, Antranikian G, Märkl H (1996) Fermentation of extremophilic microorganisms. *FEMS Microbiol Rev* 18:271-285
- Koller M, Hesse P, Bona R, Kutschera C, Atlic A, Braunegg G (2007) Biosynthesis of high quality polyhydroxyalkanoate co- and terpolyesters for potential medical application by the archaeon *Haloferax mediterranei*. *Macromol Symp* 253:33-39
- Kolp S, Pietsch M, Galinski EA, Gütschow M (2006) Compatible solutes as protectants for zymogens against proteolysis. *Biochim Biophys Acta* 1764:1234-1242
- Koyama N, Doi Y (1995) Continuous production of poly(3-hydroxybutyrate-co-3-hydroxyvalerate) by *Alcaligenes eutrophus*. *Biotechnol Lett* 17:281-284
- Kushner DJ (1978) Life in high salt and solute concentrations. In: Kushner DJ (ed) *Microbial Life in Extreme Environments*. Academic Press, London. pp 317-368
- Lanyi JK (1974) Salt-dependent properties of proteins from extremely halophilic bacteria. *Bacteriol Rev* 38:272-290
- Lapidot A, Iakobashvili R, Malin G (1999) Methods for DNA amplification and sequencing. Patent WO1999041410. 1999 August 19
- Leaf TA, Peterson MS, Stoup SK, Somers D, Srienc F (1996) *Saccharomyces cerevisiae* expressing bacterial polyhydroxybutyrate synthase produces poly-3-hydroxybutyrate. *Microbiology* 142:1169-1180
- Le Dain AC, Saint N, Kloda A, Ghazi A, Martinac B (1998) Mechanosensitive ion channels of the archaeon *Haloferax volcanii*. *J Biol Chem* 273:12116-12119
- Lee SY (1996a) Bacterial polyhydroxyalkanoates. *Biotechnol Bioeng* 49:1-14
- Lee SY (1996b) Plastic bacteria? Progress and prospects for polyhydroxyalkanoate production in bacteria. *Trends Biotechnol* 14:431-438
- Lee YW, Yoo YJ, Yang JW (1995) Optimization of two-stage continuous culture system for production of poly- β -hydroxybutyrate. *Korean J Chem Eng* 12:481-484
- Lemoigne M (1926) Produit de déshydratation et de polymérisation de l'acide β -oxybutyrique. *Bull Soc Chim Biol* 8:770-782
- Lentzen G, Schwarz T (2006) Extremolytes: natural compounds from extremophiles for versatile applications. *Appl Microbiol Biotechnol* 72:623-634
- Lippert G, Galinski EA (1992) Enzyme stabilization by ectoine-type compatible solutes: protection against heating, freezing and drying. *Appl Microbiol Biotechnol* 37:61-65

- Louis P, Galinski EA (1997) Characterization of genes for the biosynthesis of the compatible solute ectoine from *Marinococcus halophilus* and osmoregulated expression in *Escherichia coli*. *Microbiology* 143:1141-1149
- Louis P, Trüper HG, Galinski EA (1994) Survival of *Escherichia coli* during drying and storage in the presence of compatible solutes. *Appl Microbiol Biotechnol* 41:684-688
- Madison LL, Huisman GW (1999) Metabolic engineering of poly(3-hydroxyalkanoates): from DNA to plastic. *Microbiol Mol Biol Rev* 63:21-53
- Maltseva O, McGowan C, Fulthorpe R, Oriel P (1996) Degradation of 2,4-dichlorophenoxyacetic acid by haloalkaliphilic bacteria. *Microbiology* 142:1115-1122
- Manzanera M, García de Castro A, Tøndervik A, Rayner-Brandes M, Strøm AR, Tunnacliffe A (2002) Hydroxyectoine is superior to trehalose for anhydrobiotic engineering of *Pseudomonas putida* KT2440. *Appl Environ Microbiol* 68:4328-4333
- Manzanera M, Vilchez S, Tunnacliffe A (2004) High survival and stability rates of *Escherichia coli* dried in hydroxyectoine. *FEMS Microbiol Lett* 233:347-352
- Margesin R, Schinner F (2001) Potential of halotolerant and halophilic microorganisms for biotechnology. *Extremophiles* 5:73-83
- Martin DD, Cuilla RA, Roberts MF (1999) Osmoadaptation in Archaea. *Appl Environ Microbiol* 65:1815-1825
- Martínez-Cánovas J, Quesada E, Llamas I, Béjar V (2004) *Halomonas ventosae* sp. nov., a moderately halophilic, denitrifying, exopolysaccharide-producing bacterium. *Int J Syst Evol Microbiol* 54:733-737
- Mata JA, Martínez-Cánovas J, Quesada E, Béjar V (2002) A detailed phenotypic characterization of the type strains of *Halomonas* species. *System Appl Microbiol* 25:360-375
- Matsunaga T, Sudo H, Takemasa H, Wachi Y (1996) Sulfated extracellular polysaccharide production by the halophilic cyanobacterium *Aphanocapsa halophytica* immobilized on light-diffusing optical fibers. *Appl Microbiol Biotechnol* 45:24-27
- McGenity TJ, Gemmell RT, Grant WD, Stan-Lotter H (2000) Origins of halophilic microorganisms in ancient salt deposits. *Environ Microbiol* 2:243-250
- McMeekin TA, Nichols PA, Nichols SD, Juhasz A, Franzmann PD (1993) Biology and biotechnological potential of halotolerant bacteria from Antarctic saline lakes. *Experientia* 49:1042-1046
- Moreno J, Angeles VM, Olivares H, Rivas J, Guerrero M (1998) Exopolysaccharide production by the cyanobacterium *Anabaena* sp. ATCC 33047 in batch and continuous culture. *J Biotechnol* 60:175-182
- Mothes G, Schnorpfeil C, Ackermann JU (2007) Production of PHB from crude glycerol. *Eng Life Sci* 7:475-479

- Mothes G, Schubert T, Harms H, Mawkow T (2008) Biotechnological coproduction of compatible solutes and polyhydroxyalkanoates using the genus *Halomonas*. *Eng Life Sci* 8:658-662
- Oesterhelt D, Patzelt H, Kesler B (1998) Decomposition of halogenated hydrocarbons by halophilic bacteria. Patent WO1998013105. 1998 April 9
- Onishi H (1972) Halophilic amylase from a moderately halophilic *Micrococcus*. *J Bacteriol* 109:570-574
- Onishi H, Hidaka O (1978) Purification and properties of amylase produced by a moderately halophilic *Acinetobacter* sp. *Can J Microbiol* 24:1017-1023
- Onishi H, Mori T, Takeuchi S, Tani K, Kobayashi T, Kamekura M (1983) Halophilic nuclease of a moderately halophilic *Bacillus* sp.: production, purification and characteristics. *Appl Environ Microbiol* 45:24-30
- Onishi H, Sonoda K (1979) Purification and some properties of an extracellular amylase from a moderate halophile, *Micrococcus halobius*. *Appl Environ Microbiol* 38:616-620
- Onraedt AE, Walcarius BA, Soetaert WK, Wandamme EJ (2005) Optimization of ectoine synthesis through fed-batch fermentation of *Brevibacterium epidermis*. *Biotechnol Prog* 21:1206-1212
- Oren A (1986) Intracellular salt concentrations of the anaerobic halophilic eubacteria *Haloanaerobium praevalens* and *Halobacteroides halobius*. *Can J Microbiol* 32:4-9
- Oren A (1994) The ecology of extremely halophilic archaea. *FEMS Microbiol Rev* 13:415-440
- Oren A (1999) Bioenergetic aspects of halophilism. *Microbiol Mol Biol Rev* 63:334-348
- Oren A (2002a) Diversity of halophilic microorganisms: environments phylogeny, physiology, and applications. *J Ind Microbiol Biotechnol* 28:56-63
- Oren A (2002b) Halophilic microorganisms and their environments. In: Seckbach J (ed) *Cellular Origin and Life in Extreme Habitats*. Kluwer Academic, Dordrecht.
- Oren A (2006) Life at high salt concentrations. In: Dworkin M, Falkow S, Rosenberg E, Schleifer K-H, Stackebrandt E (eds) *The Prokaryotes. A Handbook on the Biology of Bacteria: Ecophysiology and Biochemistry*. Springer, New York. 2:263-282.
- Oren A (2008) Microbial life at high salt concentrations: phylogenetic and metabolic diversity. *Saline Systems (On-line Journal)* 4:2 DOI: 10.1186/1746-1448-4-2
- Oren A, Gurevich P, Azachi M, Henis Y (1992) Microbial degradation of pollutants at high salt concentrations. *Biodegradation* 3:387-398
- Oren A, Heldal M, Norland S (1997) X-ray microanalysis of intracellular ions in the anaerobic halophilic eubacterium *Haloanaerobium praevalens*. *Can J Microbiol* 43:588-592

- Oren A, Heldal M, Norland S, Galinski EA (2002) Intracellular ion and organic solute concentrations of the extremely halophilic bacterium *Salinibacter ruber*. *Extremophiles* 6:491-498
- Oriel P, Chauhan S, Maltseva O, Fu W (1997) Degradation of aromatics and haloaromatics by halophilic bacteria. In: Horikoshi K, Fukuda M, Kudo T (eds) *Microbial Diversity and Genetics of Biodegradation*. Japan Scientific Societies Press, Tokyo. pp 123-130
- Panda B, Jain P, Sharma L, Mallick N (2006) Optimization of cultural and nutritional conditions for accumulation of poly- β -hydroxybutyrate in *Synechocystis* sp. PCC 6803. *Bioresour Technol* 97:1296-1301
- Paramonov NA, Parolis LAS, Parolis H, Boán IF, Antón J, Rodríguez-Valera F (1998) The structure of the exocellular polysaccharide produced by the archaeon *Haloferax gibbonsii* (ATCC 33959). *Carbohydr Res* 309:89-94
- Park SJ, Ahn WS, Green PR, Lee SY (2001) Biosynthesis of poly(3-hydroxybutyrate-co-3-hydroxyvalerate-co-3-hydroxyhexanoate) by metabolically engineered *Escherichia coli*. *Biotechnol Bioeng* 74:81-86
- Pérez-Fillol M, Rodríguez-Valera F (1986) Potassium ion accumulation in cells of different halobacteria. *Microbiologia* 2:73-80
- Peter V, Rehm BHA (2005) In vivo monitoring of PHA granule formation using GFP-labeled PHA synthases. *FEMS Microbiol Lett* 248:93-100
- Pflüger K, Müller V (2004) Transport of compatible solutes in extremophiles. *J Bioenerg Biomembr* 36:17-24
- Philip S, Keshavarz T, Roy I (2007) Polyhydroxyalkanoates: biodegradable polymers with a range of applications. *J Chem Technol Biotechnol* 82:233-247
- Poolman B, Glaesker E (1998) Regulation of compatible solute accumulation in bacteria. *Mol Microbiol* 29:397-407
- Post FJ, Borowitzka LJ, Borowitzka MA, MacKay B, Moulton T (1983) The protozoa of a Western Australian hypersaline lagoon. *Hydrobiologia* 105:95-113
- Preusting H, Hazenberg W, Witholt B (1993) Continuous production of poly(3-hydroxyalkanoates) by *Pseudomonas oleovorans* in a high-cell-density, two-liquid-phase chemostat. *Enzyme Microbiol Technol* 15:311-316
- Preusting H, Kingma J, Witholt B (1991) Physiology and polyester formation of *Pseudomonas oleovorans* in continuous two-liquid-phase cultures. *Enzyme Microbiol Technol* 13:770-780
- Preusting H, van Houten R, Hoefs A, van Langenberghe EK, Favre-Bulle O, Witholt B (1993) High cell density cultivation of *Pseudomonas oleovorans*: growth and production of poly(3-hydroxyalkanoates) in two-liquid phase batch and fed-batch systems. *Biotechnol Bioeng* 41:550-556

- Quillaguamán J, Delgado O, Mattiasson B, Hatti-Kaul R (2006) Poly(β -hydroxybutyrate) production by a moderate halophile, *Halomonas boliviensis* LC1. *Enz Microb Technol* 38:148-154
- Quillaguamán J, Guzmán H, Van-Thuoc D, Hatti-Kaul R (2009) Synthesis and production of polyhydroxyalkanoates by halophiles: current potential and future prospects. *Appl Microbiol Biotechnol* (Accepted for publication).
- Quillaguamán J, Hashim S, Bento F, Mattiasson B, Hatti-Kaul R (2005) Poly(β -hydroxybutyrate) production by a moderate halophile, *Halomonas boliviensis* LC1 using starch hydrolysate as substrate. *J Appl Microbiol* 99:151-157
- Quillaguamán J, Hatti-Kaul R, Mattiasson B, Alvarez MT, Delgado O (2004) *Halomonas boliviensis* sp. nov., an alkalitolerant, moderate halophile bacterium isolated from soil around a Bolivian hypersaline lake. *Int J Syst Evol Microbiol* 54:721-725
- Quillaguamán J, Muñoz M, Mattiasson B, Hatti-Kaul R (2007) Optimizing conditions for poly(β -hydroxybutyrate) production by *Halomonas boliviensis* LC1 in batch culture with sucrose as carbon source. *Appl Microbiol Biotechnol* 74:981-986
- Raja LA, Joseph TC, Thampuran N, James R, Kumar KA, Viswanathan C, Bansal KC (2008) Cloning and heterologous expression of ectoine biosynthesis genes from *Bacillus halodurans* in *Escherichia coli*. *Biotechnol Lett* 30:1403-1407
- Ramsay BA, Saracovan I, Ramsay JA, Marchessault RH (1991) Continuous production of long-side-chain poly- β -hydroxyalkanoates by *Pseudomonas oleovorans*. *Appl Environ Microbiol* 57:625-629
- Reddy CSK, Ghai R, Rashmi, Lalia VC (2003) Polyhydroxyalkanoates: an overview. *Bioresour Technol* 87:137-146
- Reed RH (1984) Use and abuse of osmo-terminology. *Plant Cell Environ* 7:165-170
- Rehm BHA (2003) Polyester synthases: natural catalysts for plastics. *Biochem J* 376:15-33
- Rehm BHA (2007) Biogenesis of microbial polyhydroxyalkanoate granules: a platform technology for the production of tailor-made bioparticles. *Curr Issues Mol Biol* 9:41-62
- Risacher F (1992) Geochemistry of saline lakes and salt crusts of the Bolivian Altiplano. *Sci Geol Bulletin* 45:214
- Roberts MF (2005) Organic compatible solutes of halotolerant and halophilic microorganism. *Saline Systems (On-line Journal)* 1:5 DOI: 10.1186/1746-1448-1-5
- Rodriguez-Valera F (1993) Introduction to saline environments. In: Vreeland RH, Hochstein LI (eds) *The biology of halophilic bacteria*. CRC Press, Boca Raton, FL. pp. 1-23
- Rodriguez-Valera F, Lillo JAG (1992) Halobacteria as producers of polyhydroxyalkanoates. *FEMS Microbiol Rev* 103:181-186

- Rodriguez-Valera F, Lillo JAG, Antón J, Meseguer I (1991) Biopolymer production by *Haloferax mediterranei*. In: Rodriguez-Valera F (ed) General and Applied Aspects of Halophilic Microorganisms. Plenum Press, New York. pp 373-380
- Röling WFM, van Verseveld HW (1996) Characterization of *Tetragenococcus halophila* populations in Indonesian soy mash (kecap) fermentation. Appl Environ Microbiol 62:1203-1207
- Romano I, Giordano A, Lama L, Nicolaus B, Gambacorta A (2005) *Halomonas campaniensis* sp. nov., a haloalkaliphilic bacterium isolated from a mineral pool of Campania region, Italy. Syst Appl Microbiol 28:610-618
- Romano I, Lama L, Nicolaus B, Poli A, Gambacorta A, Giordano A (2006) *Halomonas alkaliphila* sp. nov., a novel halotolerant alkaliphilic bacterium isolated from a salt pool in Campania (Italy). J Gen Appl Microbiol 52:339-348
- Romano I, Poli A, Finore I, Huertas J, Gambacorta A, Pelliccione S, Nicolaus G, Lama L, Nicolaus B (2007) *Haloterrigena hispanica* sp. nov., an extremely halophilic archaeon from Fuente de Piedra, southern Spain. Int J Syst Evol Microbiol 57:1499-1503
- Rosenberg A (1983) *Pseudomonas halodurans* sp. nov., a halotolerant bacterium. Arch Microbiol 136:117-123
- Salehizadeh H, Van Loosdrecht MCM (2004) Production of polyhydroxyalkanoates by mixed culture: recent trends and biotechnological importance. Biotechnol Adv 22:261-279
- Sauer T, Galinski EA (1998) Bacterial milking: a novel bioprocess for production of compatible solutes. Biotechnol Bioeng 57: 306-313
- Schleyer M, Schmid R, Bakker EP (1993) Transient, specific and extremely rapid release of osmolytes from growing cells of *Escherichia coli* K-12 exposed to hypoosmotic shock. Arch Microbiol 160:424-431
- Schnoor M, Voß P, Cullen P, Böking T, Galla HJ, Galinski EA, Lorkowski S (2004) Characterization of the synthetic compatible solute homoectoine as a potent PCR enhancer. Biochem Biophys Res Commun 322:867-872
- Schubert T, Maskow T, Benndorf D, Harms H, Breuer U (2007) Continuous synthesis and excretion of the compatible solute ectoine by a transgenic, nonhalophilic bacterium. Appl Environ Microbiol. 73:3343-3347
- Servant-Vildary S, Roux M (1990) Multivariate analysis of diatoms and water chemistry in Bolivian saline lakes. Hydrobiologia 197:267-290
- Severina LO, Usenko IA, Plakunov VK (1989) Biosynthesis of an exopolysaccharide by the extreme halophilic archaebacterium *Halobacterium mediterranei*. Microbiology 58:441-445
- Shah V, Garg N, Madamwar D (1999) Exopolysaccharide production by a marine cyanobacterium *Cyanothece* sp.: application in dye removal by its gelation phenomenon. Appl Biochem Biotechnol 82:81-90

- Shi H, Shiraishi M, Shimizu K (1997) Metabolic flux analysis for biosynthesis of poly(β -hydroxybutyric acid) in *Alcaligenes eutrophus* from various carbon sources. *J Ferment Bioeng* 84:579-587
- Sleator RD, Hill C (2001) Bacterial osmoadaptation: the role of osmolytes in bacterial stress and virulence. *FEMS Microbiol Rev* 26:49-71
- Stan-Lotter H, Doppler E, Jarosch M, Radax C, Gruber C, Inatomi K (1999) Isolation of a chymotrypsinogen B-like enzyme from the archaeon *Natronomonas pharaonis* and other halobacteria. *Extremophiles* 3:153-161
- Steinbüchel A (2001) Perspectives for biotechnological production and utilization of biopolymers: metabolic engineering of polyhydroxyalkanoate biosynthesis pathways as a successful example. *Macromol Biosci* 1:1-24
- Steinbüchel A, Valentin HE (1995) Diversity of bacterial polyhydroxyalkanoic acids. *FEMS Microbiol Lett* 128:219-228
- Strazzullo G, Gambacorta A, Vella FM, Immirzi B, Romano I, Calandrelli V, Nicolaus B, Lama L (2008) Chemical-physical characterization of polyhydroxyalkanoates recovered by means of a simplified method from cultures of *Halomonas campaniensis*. *World J Microbiol Biotechnol* 24:1513-1519
- Sudesh K, Abe H, Doi Y (2000) Synthesis, structure and properties of polyhydroxyalkanoates: biological polyesters. *Prog Polym Sci* 25:1503-1555
- Sukharev SI, Blount P, Martinac B, Kung C (1997) Mechanosensitive channels of *Escherichia coli*: the MscL gene, protein, and activities. *Annu Rev Physiol* 59:633-657
- Suriyamongkol P, Weselake R, Narine S, Moloney M, Shah S (2007) Biotechnological approaches for the production of polyhydroxyalkanoates in microorganisms and plants – a review. *Biotechnol Adv* 25:148-175
- Suzuki T, Yamane T, Shimizu S (1986) Mass production of poly- β -hydroxybutyric acid by fed-batch culture with controlled carbon/nitrogen feeding. *Appl Microbiol Biotechnol* 24:370-374
- Sylvestre F, Servant-Vildary S, Roux M (2001) Diatom-based ionic concentration and salinity models from the south Bolivian Altiplano. *J Paleolimn* 25:279-295
- Thomas CP, Duvall ML, Robertson EP, Barrett KB, Bala GA (1993) Surfactant-based EOR mediated by naturally occurring microorganisms. *Soc Petrol Eng Reservoir Eng* 11:285-291
- Thomas MK, Nakas JP, Tanenbaum SW (2006) Polyhydroxyalkanoate copolymers from forest biomass. *J Ind Microbiol Biotechnol* 33:616-626
- Thongthai C, Suntinanalert P (1991) Halophiles in Thai fish sauce (nam pla). In: Rodriguez-Valera F (ed) *General and Applied Aspects of Halophilic Microorganisms*. Plenum Press, New York. pp 381-388
- Thongthai C, McGenity TJ, Suntinanalert P, Grant WD (1992) Isolation and characterization of an extremely halophilic archaeobacterium from

- traditionally fermented Thai fish sauce (nam pla). *Lett Appl Microbiol* 14:111-114
- Tokiwa Y, Ugwu CU (2007) Biotechnological production of (*R*)-3-hydroxybutyric acid monomer. *J Biotechnol* 132:264-272
- Trüper HG, Galinski EA (1990) Biosynthesis and fate of compatible solutes in extremely halophilic phototrophic eubacteria. *FEMS Microbiol Rev* 75:247-254
- Tsuge T (2002) Metabolic improvements and use of inexpensive carbon sources in microbial production of polyhydroxyalkanoates. *J Biosci Bioeng* 94:579-584
- Upasani V, Desai S (1990) Sambhar Salt Lake. Chemical composition of the brines and studies on haloalkaliphilic archaebacteria. *Arch Microbiol* 154:589-593
- Valappil SP, Boccaccini AR, Bucke C, Roy I (2007) Polyhydroxyalkanoates in Gram-positive bacteria: insights from the genera *Bacillus* and *Streptomyces*. *Antonie van Leeuwenhoek* 91:1-17
- Valentin HE, Dennis D (1997) Production of poly(3-hydroxybutyrate-co-4-hydroxybutyrate) in recombinant *Escherichia coli* grown on glucose. *J Biotechnol* 58:33-38
- Van Qua D, Simidu U, Taga N (1981) Purification and some properties of halophilic protease produced by a moderately halophilic marine *Pseudomonas* sp. *Can J Microbiol* 27:505-510
- Vargas C, Argandoña M, Reina-Bueno M, Rodríguez-Moya J, Fernández-Aunión C, Nieto JJ (2008) Unravelling the adaptation responses to osmotic and temperature stress in *Chromohalobacter salexigens*, a bacterium with broad salinity tolerance. *Saline Systems (On-line Journal)* 4:14 DOI: 10.1186/1746-1448-4-14
- Ventosa A, Nieto JJ (1995) Biotechnological applications and potentialities of halophilic microorganisms. *World J Microbiol Biotechnol* 11:85-94
- Vijayendra SVN, Rastogi NK, Shamala TR, Anil Kumar PK, Kshama L, Joshi GJ (2007) Optimization of polyhydroxybutyrate production by *Bacillus* sp. CFR 256 with corn steep liquor as a nitrogen source. *Indian J Microbiol* 47:170-175
- Vilhelmsson O, Hafsteinsson H, Kristjánsson JK (1996) Isolation and characterization of moderately halophilic bacteria from fully cured salted cod (bachalao). *J Appl Bacteriol* 81:95-103
- Villar M, de Ruiz Holgado AP, Sanchez JJ, Trucco RE, Oliver G (1985) Isolation and characterization of *Pediococcus halophilus* from salted anchovies (*Engraulis anchoita*). *Appl Environ Microbiol* 49:664-666
- Waino M, Tindall BJ, Ingvorsen K (2000) *Halorhabdus utahensis* gen. nov., sp. nov., an aeobic, extremely halophilic member of the archaea from Great Salt Lake, Utah. *Int J Syst Evol Microbiol* 50:183-190

- Wang D, Tang Q (1989) *Natronobacterium* from soda lakes of China. In: Hattori T, Ishida Y, Maruyama Y, Morita RY, Uchida A (eds) *Recent Advances in Microbial Ecology*. Japan Scientific Societies Press, Tokyo. pp 68-72
- Wang F, Lee SY (1997) Poly(3-hydroxybutyrate) production with high productivity and high polymer content by a fed-batch culture of *Alcaligenes latus* under nitrogen limitation. *Appl Environ Microbiol* 63:3703-3706
- Ward DM, Brock TD (1978) Hydrocarbon biodegradation in hypersaline environments. *Appl Environ Microbiol* 35:353-359
- Welsh DT (2000) Ecological significance of compatible solute accumulation by micro-organisms: from single cells to global climate. *FEMS Microbiol Rev* 24:263-290
- Williams MD, Fieno AM, Grant RA, Sherman DH (1996) Expression and analysis of a bacterial poly(3-hydroxyalkanoate) synthase in insect cells using baculovirus system. *Protein Expression Purif* 7:203-211
- Wong HH, Lee SY (1998) Poly-(3-hydroxybutyrate) production from whey by high-density cultivation of recombinant *Escherichia coli*. *Appl Microbiol Biotechnol* 50:30-33
- Woolard CR, Irvine RL (1994) Biological treatment of hypersaline waste-water by a biofilm of halophilic bacteria. *Water Environ Res* 66:230-235
- Xu X-W, Ren P-G, Liu S-J, Wu M, Zhou P-J (2005) *Natrianema altunense* sp. nov., an extremely halophilic archaeon isolated from a salt lake in Altun Mountain in Xinjiang, China. *Int J Syst Evol Microbiol* 55:1311-1314
- Xu Y, Zhou P, Tian X (1999) Characterization of two novel haloalkaliphilic archaea *Natronorubrum bangense* gen. nov., sp. nov. and *Natronorubrum tibetense* gen. nov., sp. nov. *Int J Syst Bacteriol* 49:261-266
- Yakimov MM, Timmis KN, Wray V, Fredrickson HL (1995) Characterization of a new lipopeptide surfactant produced by thermotolerant and halotolerant subsurface *Bacillus licheniformis* BAS50. *Appl Environ Microbiol* 61:1706-1713
- Yamane T, Fukunaga M, Lee YW (1996) Increased PHB productivity by high-cell-density fed-batch culture of *Alcaligenes latus*, a growth-associated PHB producer. *Biotechnol Bioeng* 50:197-202
- Yasuhiko Y, Yoshio K, Eiichiro K, Yasuhiro T, Seichi S (1997) Production of L-amino acid by fermentation method using ectoine. Japanese Patent JP9271382. 1997 October 21
- Zalar P, de Hoog GS, Gunde-Cimerman N (1999) *Trimmatostroma salinum*, a new species from hypersaline water. *Studies Mycol* 43:57-62
- Zheng MP, Tang JY, Liu JY, Zhang FS (1993) Chinese saline lakes. *Hydrobiologia* 267:23-36

ORIGINAL ARTICLE

Utilization of agricultural residues for poly(3-hydroxybutyrate) production by *Halomonas boliviensis* LC1

D. Van-Thuoc^{1,2}, J. Quillaguamán¹, G. Mamo¹ and B. Mattiasson¹

1 Department of Biotechnology, Centre for Chemistry and Chemical Engineering, Lund University, Lund, Sweden

2 Department of Micro-biotechnology, Faculty of Agro-Biology, Hanoi University of Education, Hanoi, Viet Nam

Keywords

anaerobic digestion, *Halomonas boliviensis*, moderate halophile, poly(3-hydroxybutyrate), potato waste, wheat bran hydrolysate.

Correspondence

Jorge Quillaguamán, Department of Biotechnology, Centre for Chemistry and Chemical Engineering, Lund University, PO Box 124, Lund SE-221 00, Sweden.
E-mail: jorge.quillaguaman@biotek.lu.se

2007/0161: received 19 July 2006, revised 28 June 2007 and accepted 3 July 2007

doi:10.1111/j.1365-2672.2007.03553.x

Abstract

Aims: Utilization of cheap and readily available agricultural residues as cheap carbon sources for poly(3-hydroxybutyrate) (PHB) production by *Halomonas boliviensis*.

Methods and Results: Wheat bran was hydrolysed by a crude enzyme preparation from *Aspergillus oryzae* NMI to provide a mixture of reducing sugars composed mainly of glucose, mannose, xylose and arabinose. Growth of *H. boliviensis* using a mixture of glucose (0.75% w/v) and xylose (0.25% w/v) in the medium led to a PHB content and concentration of 45 wt% and 1 g l⁻¹, respectively, after 30 h. A similar PHB concentration was attained when *H. boliviensis* was grown on wheat bran hydrolysate but with a lower PHB content, 34 wt%. In a batch cultivation mode in a fermentor, using 1.8% (w/v) reducing sugars, the maximum PHB accumulation by *H. boliviensis* was attained in 20 h, but was reduced to about 30 wt%. By adding butyric acid (0.8% v/v), sodium acetate (0.8% w/v) and decreasing the reducing sugars concentration to 1.0% w/v in the medium, PHB accumulation and concentration were increased to 50 wt% and 4 g l⁻¹, respectively, after 20 h. Butyric acid and sodium acetate for PHB production could also be provided by anaerobic digestion of solid potato waste.

Conclusions: Cheap and readily available agricultural residues can be used as substrates to produce PHB. The production of PHB by *H. boliviensis* using wheat bran hydrolysate as source of carbon is expected to reduce the production cost and motivates further studies.

Significance and Impact of the Study: Large-scale commercial utilization of PHB is mainly hampered by its high production cost. Carbon source for PHB production accounts up to 50% of the total production costs. Thus, the use of waste agricultural residues can substantially reduce the substrate cost (and in turn even provide value to the waste), and can downsize the production costs. This improves the market competitiveness. Studies on PHB production by moderate halophiles were recently initiated with *H. boliviensis* and findings show that it has potential for commercial exploitation. PHB production by *H. boliviensis* using wheat bran and potato waste is hence interesting.

Introduction

Petrochemical-based plastics such as polyethylene and polypropylene are amongst the most used materials because of their physicochemical properties and low cost

(c. 1\$ per kg) (Panda *et al.* 2006). However, it is well known that these materials are not biologically degradable, causing an increasing solid waste stream with negative environmental effects. Biodegradability of plastics has been proposed as a solution to overcome this

problem. Interest in biodegradable plastics for packaging, medical, agricultural and fisheries applications has increased in recent years (Palmisano and Pettigrew 1992; Rehm 2006).

Polyhydroxyalkanoates (PHAs), a group of biodegradable polymers of biological origin, have attracted considerable industrial interest. PHAs are accumulated intracellularly as reserves of carbon and energy by a wide variety of bacteria (Anderson and Dawes 1990; Bertrand *et al.* 1990; Sudesh *et al.* 2000), usually when grown under limitation of a nutrient such as O, N, P, S, or trace elements like Mg, Ca, Fe and in the presence of excess carbon (Lee 1996b; Sudesh *et al.* 2000; Kessler and Witholt 2001). Of the large family of PHAs, the homopolymer poly(3-hydroxybutyrate) (PHB) is the most extensively studied. It possesses mechanical properties similar to the common petrochemical-based synthetic thermoplastics, and has been used to make various products, including films, coated paper, compost bags, disposable food service-ware, and moulded products such as bottles and razors. After use, it can be degraded to carbon dioxide and water (or methane under anaerobic conditions) by micro-organisms in the environment (Mas-Castella *et al.* 1995; Lee 1996b; Du *et al.* 2001; Nonato *et al.* 2001; Tokiwa and Calabia 2004).

Nevertheless, the production cost of PHB (c. 4–6\$ per kg) is high compared with that of chemical synthetic nonbiodegradable plastics (Choi and Lee 1999). The efficiency and economics of the manufacturing process of PHB is determined by the price of the carbon source by the fermentation process and the downstream processing of the polymer. About 40–50% of the total production cost is attributed to the carbon source – often refined substrates, e.g. glucose and sucrose are supplemented in the medium to produce the polymer (Bertrand *et al.* 1990; Lee 1996a; Choi and Lee 1999). Hence, the development of fermentation strategies that allow high PHB content and productivity from cheap carbon sources is important.

Recently, PHB production by *Halomonas boliviensis* LC1, a moderately halophilic bacterium, has been reported (Quillaguamán *et al.* 2005, 2006, 2007). This bacterium is able to produce high PHB content (50–80 wt%) from various carbon sources including volatile fatty acids (VFAs), mono- and disaccharides and starch hydrolysate. In the present work, we studied the production of PHB by *H. boliviensis* from wheat bran hydrolysate (obtained by treatment with hydrolytic enzymes from *Aspergillus oryzae* NM1) and potato residuals (obtained after anaerobic digestion). Such hydrolysates are inexpensive carbon and nitrogen sources (Choi and Lee 1999), and may be readily available for polyester

production when utilized under optimum fermentation conditions.

Materials and methods

Microbial strains and maintenance

Halomonas boliviensis LC1^T (=DSM 15516^T) was maintained at 4°C on solid HM medium (Quillaguamán *et al.* 2004), containing (% w/v): NaCl, 4.5; MgSO₄·7H₂O, 0.025; CaCl₂·2H₂O, 0.009; KCl, 0.05; NaBr, 0.006; peptone, 0.5; yeast extract, 1.0; glucose, 0.1; and granulated agar, 2.0. The pH of the medium was adjusted to 7.5 using 5 mol l⁻¹ NaOH solution.

Aspergillus oryzae NM1 was maintained by monthly subculture on solid medium containing (% w/v): KNO₃, 0.3; MgSO₄·7H₂O, 0.05; KH₂PO₄, 0.1; KCl, 0.05; NaCl, 0.05; starch, 2.0 and agar, 2.0, pH 5.5.

Production and recovery of polysaccharide hydrolysing enzymes

Aspergillus oryzae NM1 was grown in a medium using wheat bran (Cerealía, Järna, Sweden) as the main carbon source. Wheat bran composition is shown in Table 1. The strain was grown at 30°C in 1 l flasks with shaking at 200 rev min⁻¹ in 200 ml liquid medium containing (% w/v): KNO₃, 0.3; KH₂PO₄, 0.1; MgSO₄·7H₂O, 0.05; KCl, 0.05; NaCl, 0.05; rice bran, 0.5 for 72 h. The fungus was separated by centrifugation at 8000 g for 20 min at 4°C; then the clarified supernatant was concentrated 10 times by ammonium sulfate precipitation, sterilized by filtering through a 0.2 µm membrane, and stored at -20°C until

Table 1 Wheat bran composition per 100 g as described by the supplier Cerealía (Järna, Sweden)

Component	Amount
Fibre	50 g
Carbohydrates	15 g
free sugars	1.5 g
Protein	14 g
Fats	6 g
Sodium	0.003 g
Thiamine	0.66 mg
Riboflavin	0.32 mg
Niacin	26 mg
Vitamin B ₆	1.4 mg
Folacin	0.26 mg
Potassium	1100 mg
Iron	11 mg
Magnesium	480 mg
Zinc	7.3 mg

required. The concentrate was used as a source of polysaccharide hydrolysing enzymes.

Wheat bran hydrolysis by *Aspergillus oryzae* NM1 enzyme concentrate

Different amounts of the enzyme concentrate, as obtained above, were mixed with 30 g of wheat bran and 150 ml of a phosphate buffer solution at pH 6 in 1 l flasks. The mixture was incubated at 50°C and the stirrer speed was set at 160 rev min⁻¹. The mixture was centrifuged and filtered through a Munktell analytical filter paper (Grycksbo, Sweden), and the filtrate containing the reducing sugars was used as carbon source for polyester production by *H. boliviensis*.

Hydrolysis of potato waste

The hydrolysis was achieved in cylindro-conical anaerobic reactors with 2 dm³ working capacity as previously described (Parawira *et al.* 2004). Subsequently, the hydrolysate was adjusted to pH 9, heated for 5 min in a boiling water bath and filtered through a Munktell analytical filter paper to eliminate suspended solids.

Poly(3-hydroxybutyrate) production in flasks

Seed culture of *H. boliviensis* was grown in a modified HM medium, HM-I (Quillaguamán *et al.* 2005) containing (% w/v): glucose, 1.0; yeast extract, 0.2; NaCl, 4.5; MgSO₄·7H₂O, 0.038; CaCl₂·2H₂O, 0.013; KCl, 0.075; NaBr, 0.02. *Halomonas boliviensis* was grown in 30 ml of HM-I medium in 100 ml flasks with shaking at 200 rev min⁻¹ at 30°C until the culture broth reached an optical density (OD₆₀₀) of 0.50–0.55. Subsequently, 2 ml of this culture was inoculated in 1 l flasks containing 100 ml HM-II medium (having the same composition as HM-I medium but without glucose) with different carbon sources. The cultures were incubated at 35°C with shaking at 200 rev min⁻¹.

Poly(3-hydroxybutyrate) production in a fermentor

Halomonas boliviensis was first grown at 30°C in 150 ml HM-I medium in 1 l flasks, with shaking at 200 rev min⁻¹, for about 13 h until the cell density of 1 g l⁻¹ (OD₆₀₀ about 0.48–0.50) was reached. This culture medium was used to inoculate a 2-l fermentor vessel (Voyager, Luton, UK) containing 1.35 l of cultivation medium. Temperature was kept at 35°C during the process, antifoam was added when needed and the pH of the medium was maintained at 7.7 by using 5 mol l⁻¹ NaOH/HCl. The air inflow rate and agitation speed were

initially set to 1.0 l min⁻¹ and 700 rev min⁻¹ for all fermentations, and were increased up to 4.0 l min⁻¹ and 900 rev min⁻¹ after 2 h when a decrease from the initial dissolved oxygen concentration was detected. The effect of various nutrients such as yeast extract, wheat bran hydrolysate and organic acids was studied under these conditions.

Poly(3-hydroxybutyrate) isolation for nuclear magnetic resonance-spectroscopic analysis

PHB chemical structure was determined as reported previously (Quillaguamán *et al.* 2006). *Halomonas boliviensis* cells containing the polymer, were harvested from 500 ml of culture broth by centrifugation at 10 000 g for 10 min, washed once with water and finally resuspended in water and lyophilized. PHB was recovered from lyophilized cells by extraction for 30 h with chloroform in a Soxhlet apparatus (Duran, Germany), and concentrated by evaporating the solvent under vacuum. The polymer was precipitated from the concentrated solution with 10 volumes of ethanol and the resulting PHB granulates were filtered twice. The ¹H nuclear magnetic resonance (NMR) spectrum was recorded at 500 MHz with a Bruker ARX500 Spectrometer (Bruker, Sikerstrifen, Germany) at room temperature using deuterated chloroform as internal reference solvent. The spectrum was evaluated using standard Bruker UxNMR software.

Quantitative analysis

Samples were withdrawn at defined time intervals during the cultivation of *H. boliviensis* and were analysed for cell dry weight (CDW), PHB content and residual cell mass (RCM).

CDW was determined by centrifuging 3 ml of the culture samples at 2000 g for 15 min in a preweighed centrifuge tube, the pellet washed twice with 3 ml distilled water, and dried at 75°C until constant weight was obtained.

PHB quantification was performed according to the method of Law and Slepecky (1961). The dried pellets containing intracellular PHB were hydrolysed using 10 ml of concentrated sulfuric acid for 1 h to obtain crotonic acid, and the mixture was then cooled to room temperature and quantified by measuring absorbance at 235 nm. Analysis was performed in triplicates for all samples.

RCM was defined as the CDW minus PHB concentration, while PHB content (wt%) was obtained as the percentage of the ratio of PHB concentration to CDW (Lee *et al.* 2000).

Wheat bran hydrolysate composition was analysed by HPLC using an Aminex HPX-87P column (Bio-Rad, Hercules, CA, USA) and refractive index detector. The

chromatography was performed at 85°C using deionized water as mobile phase at a flow rate of 0.6 ml min⁻¹.

Reducing sugars concentration was determined by the dinitrosalicylic acid (DNS) method (Miller 1959).

Total protein concentration in the hydrolysate was quantified using the BCA (Bicinchoninic Acid)-method (Stoscheck 1990).

VFAs in the potato hydrolysate were determined using HPLC with a Bio-Rad column 125-0115. The column temperature was 65°C. Sulfuric acid (1 mmol l⁻¹) was used as mobile phase and the liquid flow rate was 0.8 ml min⁻¹. The fatty acids were monitored by UV absorption at 208 nm (Parawira *et al.* 2004).

Enzyme assay

Enzyme activities were determined from the amount of reducing sugar formed using the DNS method (Miller 1959).

Amylase activity

The crude enzyme preparation (50 µl) was incubated with 450 µl of 3 g l⁻¹ starch solution in 50 mmol l⁻¹ phosphate buffer (pH 6.0) at 50°C for 5 min.

Xylanase activity

The crude enzyme preparation (50 µl) was incubated with 450 µl of 10 g l⁻¹ xylane solution in 50 mmol l⁻¹ phosphate buffer (pH 6.0) at 50°C for 5 min.

The reactions were stopped by the addition of DNS reagent, after which the samples were placed in a boiling water bath for 10 min. The samples were cooled in the water for 10 min and then absorbance read at 540 nm. Glucose was used as the calibration standard for amylase activity and xylose was used as the calibration standard for xylanase activity. One unit of enzyme was defined as the amount of enzyme releasing 1 µmol reducing sugar per minute under the standard assay conditions.

Results

Effect of enzyme concentration on total reducing sugar

Aspergillus oryzae produced 15 U ml⁻¹ xylanase and 11 U ml⁻¹ amylase activities under the culture conditions provided and using wheat bran as the main carbon source. The enzymes were concentrated by ammonium sulfate precipitation to reach activity levels of 110 U ml⁻¹ xylanase and 80 U ml⁻¹ amylase activities. Wheat bran hydrolysis was studied using enzymes concentration up to 7.4 U ml⁻¹ amylase and 9.8 U ml⁻¹ xylanase at 50°C. In all cases, the reducing sugars concentration reached constant levels after 5 h of treatment (data not shown).

In all subsequent experiments, the wheat bran was treated with the enzyme solution containing 5.1 U ml⁻¹ amylase and 6.8 U ml⁻¹ xylanase for 5 h, which was enough to yield the maximal amount of reducing sugar. The wheat bran hydrolysate had a final concentration of 32 g l⁻¹ reducing sugars, which was mainly composed of 52.8% glucose, 17.2% xylose, 17.4% mannose and 12.6% arabinose. The total protein concentration in the hydrolysate was 15.6 g l⁻¹.

Effect of carbon source on PHB accumulation in shake flasks

Wheat bran hydrolysate, composed of a complex mixture of hexoses and pentoses, was used as C-source for PHB production. PHB chemical structure was determined by NMR-spectroscopic analysis (Fig. 1). Substrate uptake and metabolic assimilation of both kinds of sugars are different, and hence should have different effects on cell concentration and PHB accumulation by *H. boliviensis*. PHB production was first studied using mixtures of glucose and xylose at varying ratios as carbon source, and was compared with the production obtained with wheat bran hydrolysate (Table 2). At two different concentrations, glucose showed to be a better substrate for PHB accumulation with respect to xylose when supplemented in the medium. Increasing glucose : xylose ratio was

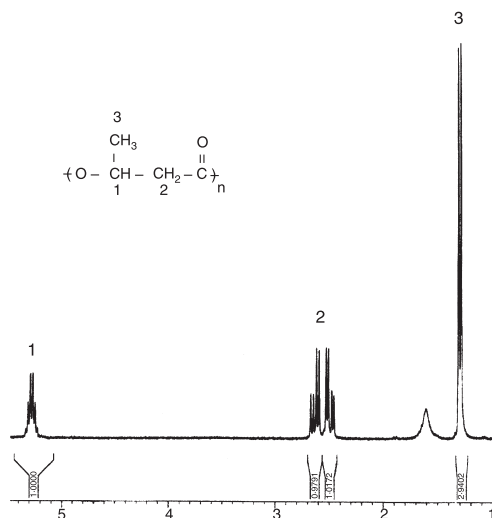

Figure 1 ¹H-nuclear magnetic resonance spectrum showing the carbon composition of the monomers belonging to the polymer extracted and purified from *Halomonas boliviensis* cells. Deuterated chloroform was used as internal reference solvent.

Carbon source		CDW (g l ⁻¹)	PHB content (wt%)	PHB conc. (g l ⁻¹)	Residual cell mass (g l ⁻¹)
Glucose % (w/v)	Xylose % (w/v)				
1	–	2.1 (±0.04)	39.3 (±1.11)	0.83	1.29
0.5	–	1.7 (±0.13)	32.4 (±1.07)	0.60	1.24
0.75	0.25	2.2 (±0.07)	44.9 (±0.41)	1.00	1.23
0.5	0.5	2.2 (±0.02)	43.3 (±0.83)	0.96	1.26
0.25	0.75	2.0 (±0.09)	29.3 (±0.52)	0.6	1.43
–	0.5	1.4 (±0.02)	13.9 (±0.50)	0.19	1.17
–	1	1.5 (±0.10)	23.1 (±1.83)	0.35	1.17
Wheat bran hydrolysate (1% w/v reducing sugars)		3.19 (±0.09)	33.8 (±2.17)	1.08	2.11

Experiments were performed in 1 l flasks containing 200 ml of HM-I medium at 35°C and 200 rev min⁻¹ for 30 h. Between 5 and 7 mg of dried cells were used to determine the PHB content. The numbers in brackets represent the SD of the average values.

found to be favourable for PHB accumulation (Table 2). Highest PHB concentration of 1.0 g l⁻¹ was obtained when cells were grown with 0.75% (w/v) glucose and 0.25% (w/v) xylose in the HM-II medium (Table 2). A similar PHB concentration (1.08 g l⁻¹) was reached when wheat bran hydrolysate was supplied as C-source; though PHB content was lower and the RCM generated was higher (Table 2).

Effect of N- and C-sources on PHB production by *Halomonas boliviensis* in a fermentor

We have previously determined that yeast extract can enhance both cell mass and PHB content even at concentrations as high as 1.5% (w/v) when sucrose is used as sole carbon source and under controlled conditions in a fermentor (Quillaguamán *et al.* 2007). For this work, the influence of yeast extract concentration on PHB production was also studied. HM-II medium was supplemented with the wheat bran hydrolysate to reach a reducing sugar concentration of 1.8% (w/v) (found to be optimum in shake flask experiments). As depicted in Fig. 2, increase in yeast extract concentration from 0.8 to 1.5% (w/v) led to an increase in cell dry weight but the PHB content decreased from 30 to 18 wt%.

While maintaining the yeast extract concentration at 0.5% (w/v) in HM-II medium, the effect of mixing wheat bran hydrolysate with other carbon sources on PHB production was studied. PHB accumulation was improved, reaching a maximum value of 50 wt% and a PHB concentration of 4 g l⁻¹ using 1% (w/v) hydrolysate, 0.8% (w/v) sodium acetate and 0.8% (w/v) butyric acid in the medium (Fig. 3). Furthermore, the cell mass concentration was 8.0 g l⁻¹ after 20 h (Fig. 3). In order to obtain VFAs from a cheap source, potato residue was subjected

Table 2 Influence of carbon source on poly(3-hydroxybutyrate) (PHB) accumulation and cell mass concentration by *Halomonas boliviensis*

to partial anaerobic digestion. The hydrolysate contained mainly acetic and butyric acids in a solution. *Halomonas boliviensis* was grown in HM-II medium with 1% (w/v) wheat bran hydrolysate and 1% (w/v) digested potato extract as C-source. The digested potato extract added to the medium led to a final concentration of 0.56% (w/v) acetic acid and 0.4% (w/v) butyric acid. Under these conditions, cell mass concentration obtained was 6.6 g l⁻¹ and maximum PHB content was 43 wt% after 20 h of growth (Fig. 3).

Discussion

The carbon source contributes most significantly to the substrate costs in PHA production by bacteria (Bertrand *et al.* 1990; Lee 1996a; Choi and Lee 1999). The use of cheap and readily available agricultural residues is expected to substantially reduce the cost of the carbon source that can be used in fermentation (Choi and Lee 1999). The use of agricultural residues as fermentation substrates involves a hydrolysis step that releases easily metabolizable sugars. Nevertheless, the hydrolysis step should be straightforward and inexpensive to not affect negatively the overall economics. Moreover, the hydrolysis process should not result in compounds that inhibit the fermentation process. In this regard, the biocompatibility of enzymatically hydrolysed agricultural residues to fermentation process makes it interesting. However, in large-scale applications the enzyme cost can be a bottleneck. Alternative ways of reducing the enzyme cost includes the use of cheap production substrate and using crude enzyme preparation for the target application. In this study, the hydrolytic enzymes were produced cheaply using wheat bran as carbon source and used as a crude concentrate.

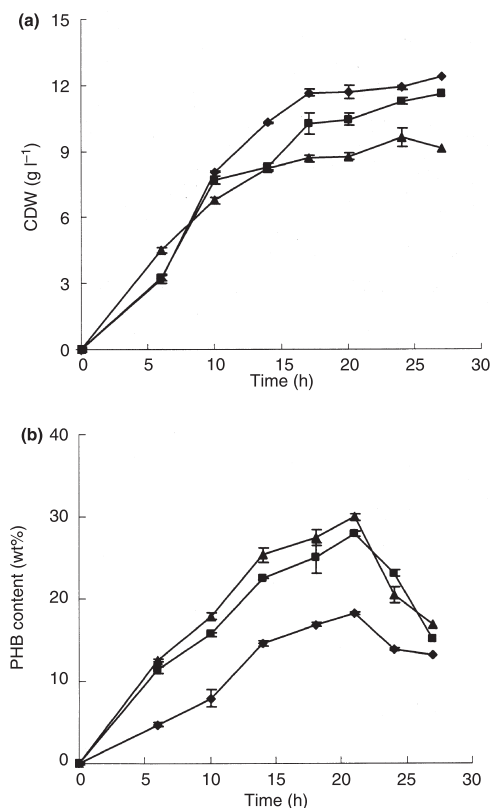

Figure 2 Influence of yeast extract concentration on poly(3-hydroxybutyrate) (PHB) production: (a) CDW and (b) PHB accumulation by *Halomonas boliviensis*. HM-II medium containing 1.8% (w/v) reducing sugars of wheat bran hydrolysate was supplemented with different concentrations of yeast extract % (w/v): ▲, 0.8; ■, 1.2; ◆, 1.5. All experiments were performed in a fermentor maintaining constant pH (7.5), temperature (35°C) and avoiding oxygen limitation by the cells. The error bars refer to the SD of the average values.

The hydrolysis of wheat bran by *A. oryzae* NM1 resulted in a reducing sugar mixture suitable for PHB production by *H. boliviensis*. Reducing sugars composition in the hydrolysate was composed mainly of hexoses (glucose and mannose) and pentoses (xylose and arabinose). Glucose was the preferred substrate for PHB synthesis (Table 2). Pentose catabolism affects the growth kinetics of various Gram-negative bacteria (Wood 1966; Shamanna and Sanderson 1979), e.g. *Escherichia coli* and *Salmonella typhimorium* generation times increase twofold when glucose is replaced by xylose under otherwise similar culture conditions

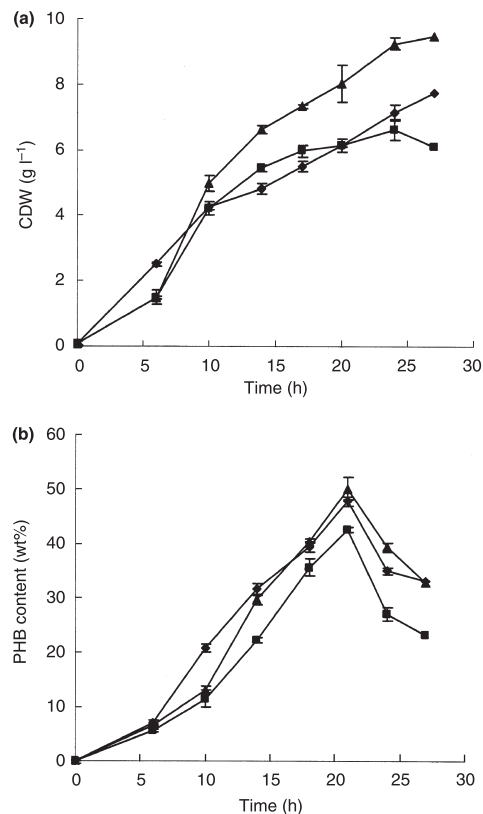

Figure 3 Influence of the carbon sources on cell dry weight (a) and poly(3-hydroxybutyrate) accumulation (b) by *Halomonas boliviensis*. Symbols used refer to different combinations of C-sources: (◆), 1% (w/v) wheat bran hydrolysate + 0.5% (w/v) sodium acetate + 0.5% (w/v) butyric acid; (▲), 1% (w/v) wheat bran hydrolysate + 0.8% (w/v) sodium acetate + 0.8% (w/v) butyric acid; (■), 1% (w/v) wheat bran hydrolysate + 1% (w/v) waste potato hydrolysate. In all cases, 0.5% (w/v) yeast extract was added to H-II medium. The error bars refer to the SD of the average values.

(Shamanna and Sanderson 1979). As shown in Table 2, the mixture of xylose and glucose provided the best conditions for cell growth and PHB accumulation by *H. boliviensis* in shake flasks.

In the fermentor, maximum PHB content in *H. boliviensis* cells was attained in 20 h, a reduction of 10 h in the production process with respect to shake flasks, although with low intracellular amounts of PHB (up to 30 wt%) (Fig. 2). Previous studies, using sucrose as C-source, showed that a high yeast extract concentration (up to 1.5% w/v) in the medium provides favourable conditions

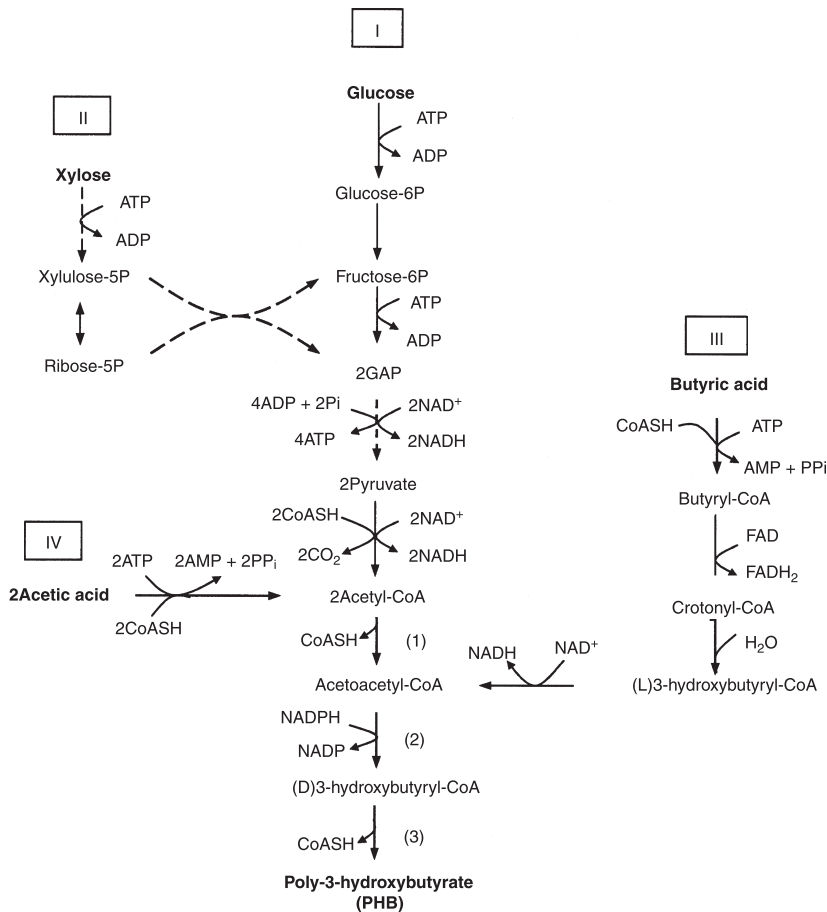

Figure 4 Pathways for the biosynthesis of poly(3-hydroxybutyrate) (PHB) from different carbon sources: (I) Glucose Embden–Meyerhof pathway; (II) Xylose via pentose-P pathway; (III) Butyric acid via acetoacetyl CoA and (IV) acetic acid. GAP refers to glyceraldehyde-3-phosphate. Pathway for the biosynthesis of PHB from acetyl CoA involves three enzymes: (i) 3-keto-thiolase, (ii) acetoacetyl-CoA reductase and (iii) PHB synthase. The scheme was adapted from previous reports (Braunegg *et al.* 1998; Steinbüchel and Fuchtenbush 1998).

for both growth and PHB production by *H. boliviensis* but excess of a complex N-source hinders PHB synthesis (Quillaguamán *et al.* 2007). PHB accumulation by this organism using wheat bran hydrolysate was improved by reducing the amount of yeast extract in the medium (Fig. 2), implying that there was an excess of N-source in HM-II medium. This is most likely related to the high protein concentration found in the hydrolysate, which provided, besides carbon, also nitrogen for the cells.

The accelerated cell growth observed in *H. boliviensis* (Fig. 2) is to be accompanied by a high concentration of

NAD(P)H that inhibits citrate synthase within the TCA, and allows PHB synthesis. Furthermore, this process results in a decrease in concentration of acetyl-CoA, hence increasing the concentration of free CoASH. High concentration of CoASH is known to inhibit the 3-keto-thiolase condensation reaction in the PHB synthesis (Jackson and Dawes 1976; Anderson and Dawes 1990; Koyama and Doi 1993; Du *et al.* 2001; Kessler and Witholt 2001). In general, PHB synthesis depends upon intracellular NADPH concentration and/or NAD(P)H/NADP ratio (Dawes and Senior 1973; Shi *et al.* 1997).

Different substrates lead to characteristic amounts of the reducing power, whereas mixtures of substrates such as fructose and methanol have demonstrated to influence significantly the synthesis of PHB (Ackermann and Babel 1997), hence utilization of different other substrates that lead to distinct amounts of NAD(P)H were thought to provide appropriate balances for the polymer production (Babel *et al.* 2001). Figure 4 provides scheme of PHB production from different carbon sources through different metabolisms. Following these metabolisms, the amount of reducing sugars in the medium was reduced (they produce elevated amounts of NAD(P)H) in the medium, and was replaced by butyric acid and sodium acetate, NAD(P)H-poor substrates (Babel *et al.* 2001). Appropriate concentrations of sodium acetate and butyric acid led to an increment in the PHB content to 50 wt% (Fig. 3) and resulted in a PHB concentration of 4 g l⁻¹, similar to those found in other bacterial species considered to hold promise in the utilization of pentoses or organic residues as PHB precursors in batch systems (Lee 1998; Nonato *et al.* 2001; Silva *et al.* 2004). Potato waste subjected to anaerobic digestion constitutes an inexpensive source of butyric acid and acetic acid amongst other VFAs. Such VFAs were also utilized by *H. boliviensis* but with a decrease in the PHB yield to 43 wt%, most probably because of the high concentration of total protein of the digested potato waste. Early studies on PHB production by *H. boliviensis* using a mixture of butyric acid and sodium acetate as carbon sources and a reduced amount of yeast extract (0.1% w/v) as nitrogen source resulted in a PHB yield of up to 88 wt% but with a low CDW (up to 2 g l⁻¹) (Quillaguamán *et al.* 2006). The results obtained in this work show that a suitable energy balance for PHB production is to be achieved by using adequate ratios of different carbon sources, as hypostasized previously (Babel *et al.* 2001), from cheap chemicals or agricultural remnants.

An integrated cheap hydrolysis and PHB production process is a prerequisite for sustainable bioplastic production. The ability of the moderate halophile *H. boliviensis* to produce PHB from several substrates found in organic residues makes this organism a very attractive option for further research.

Acknowledgements

This study was supported by the Swedish International Development Cooperation Agency (SIDA).

References

- Ackermann, J.U. and Babel, W. (1997) Growth-associated synthesis of poly(hydroxybutyric acid) in *Methylobacterium rhodesianum* as an expression for an internal bottleneck. *Appl Microbiol Biotechnol* **47**, 144–149.
- Anderson, A.J. and Dawes, E.A. (1990) Occurrence, metabolism role, and industrial uses of bacterial polyhydroxyalkanoates. *Microbiol Rev* **54**, 450–472.
- Babel, W., Ackermann, J.U. and Breuer, U. (2001) Physiology, regulation, and limits of the synthesis of poly(3HB). In *Advances in Biochemical Engineering Biotechnology: Biopolyesters*, Vol. **71** ed. Scheper, T., Babel, W. and Steinbüchel, A. pp. 125–157. Berlin Heidelberg: Springer Press.
- Bertrand, J.-L., Ramsay, B.A., Ramsay, J.A. and Chavarie, C. (1990) Biosynthesis of poly-β-polyhydroxyalkanoates from pentoses by *Pseudomonas pseudoflava*. *Appl Environ Microbiol* **56**, 3133–3138.
- Braunegg, G., Lefebvre, G. and Genser, K.F. (1998) Polyhydroxyalkanoates, biopolyesters from renewable resources: physiological and engineering aspects. *J Biotechnol* **65**, 127–161.
- Choi, J. and Lee, S.Y. (1999) Factors affecting the economics of polyhydroxyalkanoate production by bacterial fermentation. *Appl Microbiol Biotechnol* **51**, 13–21.
- Dawes, E.A. and Senior, P.J. (1973) The role and regulation of energy reserve polymers in micro-organisms. *Adv Microbiol Physiol* **10**, 135–266.
- Du, G.C., Chen, J., Yu, J. and Lun, S.Y. (2001) Continuous production of poly-3-hydroxybutyrate by *Ralstonia eutropha* in a two-stage culture system. *J Biotechnol* **88**, 59–65.
- Jackson, F.A. and Dawes, E.A. (1976) Regulation of the tricarboxylic acid cycle and poly-β-polyhydroxyalkanoate metabolism in *Azotobacter beijerinckii* grown under nitrogen or oxygen limitation. *J Gen Microbiol* **97**, 303–312.
- Kessler, B. and Witholt, B. (2001) Factors involved in the regulatory network of polyhydroxyalkanoate metabolism. *J Biotechnol* **86**, 97–104.
- Koyama, N. and Doi, Y. (1993) Production of poly(3-hydroxybutyrate-co-3-hydroxyvalerate) from various carbon sources by batch-fed cultures of *Alcaligenes eutrophus*. *J Environ Polym Degrad* **1**, 235–240.
- Law, J.H. and Slepecky, R.A. (1961) Assay of poly-β-hydroxybutyric acid. *J Bacteriol* **82**, 33–36.
- Lee, S.Y. (1996a) Bacterial polyhydroxyalkanoates. *Biotechnol Bioeng* **49**, 1–14.
- Lee, S.Y. (1996b) Plastic bacteria? Progress and prospects for polyhydroxyalkanoate production in bacteria. *Trends Biotechnol* **14**, 431–438.
- Lee, S.Y. (1998) Poly(3-hydroxybutyrate) production from xylose by recombinant *Escherichia coli*. *Bioprocess Eng* **18**, 297–399.
- Lee, S.Y., Wong, H.H., Choi, J., Lee, S.H., Lee, S.C. and Han, C.S. (2000) Production of medium-chain-length polyhydroxyalkanoates by high-cell-density cultivation of *Pseudomonas putida* under phosphorus limitation. *Biotechnol Bioeng* **68**, 466–470.
- Mas-Castella, J., Urmeneta, J., Lafuente, R., Navarrete, A. and Guerrero, R. (1995) Biodegradation of poly-β-hydroxyalk-

- anoates in anaerobic sediments. *Int Biodet Biodeg* **35**, 155–174.
- Miller, G.R. (1959) Use of dinitrosalicylic acid reagent for determination of reducing sugar. *Anal Chem* **31**, 426–428.
- Nonato, R.V., Mantelatto, P.E. and Rossell, C.E.V. (2001) Integrated production of biodegradable plastic, sugar and ethanol. *Appl Microbiol Biotechnol* **57**, 1–5.
- Palmisano, A.C. and Pettigrew, C.A. (1992) Biodegradability of plastics. *BioScience* **42**, 680–685.
- Panda, B., Jain, P., Sharma, L. and Mallick, N. (2006) Optimization of cultural and nutritional conditions for accumulation of poly- β -hydroxyalkanoate in *Synechocystis* sp. PCC 6803. *Bioresour Technol* **97**, 1296–1301.
- Parawira, W., Murto, M., Read, J.S. and Mattiasson, B. (2004) Volatile fatty acid production during anaerobic mesophilic digestion of solid potato waste. *J Chem Technol Biotechnol* **79**, 673–677.
- Quillaguamán, J., Hatti-Kaul, R., Mattiasson, B., Alvarez, M.T. and Delgado, O. (2004) *Halomonas boliviensis* sp. nov., an alkalitolerant, moderate halophile bacterium isolated from soil around Bolivian hypersaline lake. *Int J Syst Evol Microbiol* **54**, 721–725.
- Quillaguamán, J., Hashim, S., Bento, F., Mattiasson, B. and Hatti-Kaul, R. (2005) Poly(β -hydroxybutyrate) production by a moderate halophile, *Halomonas boliviensis* LC1 using starch hydrolysate as substrate. *J Appl Microbiol* **99**, 151–157.
- Quillaguamán, J., Delgado, O., Mattiasson, B. and Hatti-Kaul, R. (2006) Poly(β -hydroxybutyrate) production by a moderate halophile, *Halomonas boliviensis* LC1. *Enz Microb Technol* **38**, 148–154.
- Quillaguamán, J., Muñoz, M., Mattiasson, B. and Hatti-Kaul, R. (2007) Optimizing conditions for poly(β -hydroxybutyrate) production by *Halomonas boliviensis* LC1 in batch culture with sucrose as carbon source. *Appl Microbiol Biotechnol* **74**, 981–986.
- Rehm, B.H.A. (2006) Genetics and biochemistry of polyhydroxyalkanoate granule self-assembly: the key role of polyester synthases. *Biotechnol Lett* **28**, 207–213.
- Shamanna, D.K. and Sanderson, K.E. (1979) Uptake and catabolism of D-xylose in *Salmonella typhimurium* LT2. *J Bacteriol* **139**, 64–70.
- Shi, H.D., Shiraishi, M. and Shimizu, K. (1997) Metabolic flux analysis for biosynthesis of Poly(β -hydroxybutyric acid) in *Alcaligenes eutrophus* from various carbon-sources. *J Ferm Bioeng* **84**, 579–587.
- Silva, L.F., Taciro, M.K., Michelin Ramos, M.E., Carter, J.M., Pradella, J.G.C. and Gomez, J.G.C. (2004) Poly(3-hydroxybutyrate) (P3HB) production by bacteria from xylose, glucose and sugarcane bagasse hydrolysate. *J Ind Microbiol Biotechnol* **31**, 245–254.
- Steinbüchel, A. and Fuchtenbush, B. (1998) Bacterial and other biological systems for polyester production. *Trends Biotechnol* **16**, 419–427.
- Stoscheck, C.M. (1990) Quantitation of protein. *Methods Enzymol* **182**, 50–69.
- Sudesh, K., Abe, H. and Doi, Y. (2000) Synthesis, structure and properties of polyhydroxyalkanoates: biological polyesters. *Prog Polym Sci* **25**, 1503–1555.
- Tokiwa, Y. and Calabia, B.P. (2004) Degradation of microbial polyesters. *Biotechnol Lett* **26**, 1181–1189.
- Wood, W.A. (1966) Carbohydrate metabolism. *Annu Rev Biochem* **35**, 521–553.

II

Poly(3-hydroxybutyrate) production by *Halomonas boliviensis* in fed-batch culture

Jorge Quillaguamán · Thuoc Doan-Van ·
Héctor Guzmán · Daniel Guzmán · Javier Martín ·
Akaraonye Everest · Rajni Hatti-Kaul

Received: 28 September 2007 / Revised: 20 November 2007 / Accepted: 21 November 2007 / Published online: 21 December 2007
© Springer-Verlag 2007

Abstract High poly(3-hydroxybutyrate) (PHB) content and volumetric productivity were achieved by fed-batch culture of *Halomonas boliviensis* using a defined medium. Initial shake flask cultivations in a minimal medium revealed that the growth of *H. boliviensis* was supported only when the medium was supplemented with aspartic acid, glycine, or glutamine. Addition of 0.1% (w/v) glutamine in the medium resulted in the highest cell dry weight (CDW; 3.9 g l⁻¹). Glutamine was replaced by the less expensive monosodium glutamate (MSG) in the medium without any notable change in the final cell density. Effect of initial concentrations of NH₄Cl and K₂HPO₄ on cell growth and PHB accumulation by *H. boliviensis* was then analyzed using a fed-batch fermentation system. The best conditions for PHB production by *H. boliviensis* were attained using 0.4% (w/v) NH₄Cl and 0.22% (w/v) K₂HPO₄ and adding MSG intermittently to the fermentor. Poly(3-hydroxybutyrate) content and CDW reached 90 wt.% and 23 g l⁻¹, respectively, after 18 h of cultivation. In order to increase CDW and PHB content, MSG, NH₄Cl, and K₂HPO₄ were initially fed to the

fermentor to maintain their concentrations at 2%, 0.4%, and 0.22% (w/v), respectively, and subsequently their feed was suppressed. This resulted in a CDW of 44 g l⁻¹, PHB content of 81 wt.%, and PHB volumetric productivity of 1.1 g l⁻¹ h⁻¹.

Keywords *Halomonas boliviensis* · Moderate halophile · Fed-batch cultivation · PHB production · Glutamate

Introduction

Since its discovery in 1925 (Lemoigne 1926), poly(3-hydroxybutyrate) (PHB), a biopolyester, has been reported in several bacterial and archaeal species (Rodriguez-Valera and Lillo 1992; Lee 1996; Steinbüchel and Fuchtenbush 1998). Poly(3-hydroxybutyrate) is stored as carbon and energy reservoir in the organisms. Being biodegradable, biocompatible, and non-toxic, the polymer has received much attention because of its potential utilization as disposable plastic-like material in several areas ranging from packing commodities to medical devices (Reddy et al. 2003; Freier et al. 2005; Williams and Martin 2005). It is currently being commercially produced by a US-based company, Metabolix, which has further plans of expansion to produce various biopolyesters by microbial fermentation processes at an annual capacity of 50,000 tonnes (Philip et al. 2007).

A suitable production system resulting in high volumetric productivities and polymer yields by the organisms is an important factor to allow an economically feasible production of PHB (Lee 1996; Choi and Lee 1999). In this respect, although a large number of organisms accumulate the polymer, only a limited number are considered as good candidates for industrial production of PHB. Among them, *Cupriavidus necator* (formerly called *Ralstonia eutropha*), *Alcaligenes latus*, *Azotobacter vinelandii*, and recombinant

J. Quillaguamán (✉) · T. Doan-Van · H. Guzmán · D. Guzmán ·
J. Martín · A. Everest · R. Hatti-Kaul
Department of Biotechnology, Center for Chemistry and Chemical
Engineering, Lund University,
P.O. Box 124, SE-221 00 Lund, Sweden
e-mail: Jorge.Quillaguaman@biotek.lu.se

T. Doan-Van
Department of Micro-biotechnology, Faculty of Agro-Biology,
Hanoi University of Education,
136 Xuan Thuy, Cau Giay,
Hanoi, Vietnam

H. Guzmán · D. Guzmán
Centro de Biotecnología, Facultad de Ciencias y Tecnología,
Universidad Mayor de San Simón,
Cochabamba, Bolivia

Escherichia coli have shown the highest polyester accumulation (ca. 70–90 wt.%) and concentrations using fed-batch systems (Lee 1996; Reddy et al. 2003). *Cupriavidus necator* requires nutrient limitation in the production medium to trigger PHB synthesis and to reach optimum polymer yields. This organism accumulates most PHB during stationary phase of growth (Kim et al. 1994). Hence, *C. necator* cells are first grown to a desired concentration without nutrient limitation and, subsequently, a nutrient is removed from the feed to begin PHB production (Kim et al. 1994; Lee 1996). The other three bacteria do not require nutrient limitation to initiate PHB synthesis, although the limitation of a nutrient in the culture medium favors high PHB accumulation by the cells. In some of these cases, complex nitrogen sources such as yeast extract or fish peptone may be used to enhance cell growth and, in turn, the volumetric productivity (Page and Cornish 1993; Lee 1996).

Halomonas boliviensis is a moderate halophile isolated from Bolivian highlands (Quillaguamán et al. 2004), which produces PHB during stationary phase of growth. High PHB yields (50–88 wt.%) have been obtained in batch cultivations from glucose, sucrose, volatile fatty acids, and hydrolyzed starch (Quillaguamán et al. 2005, 2006), which are regarded as the cheapest carbon sources for the polymer production (Choi and Lee 1999). However, the cell density reached in batch culture was low (2–3 g l⁻¹; Quillaguamán et al. 2005, 2006). Optimization of the cultivation conditions with respect to the nitrogen source, phosphate, and oxygen resulted in some improvement in cell density to 14 g l⁻¹ albeit with a relatively low PHB yield (55 wt.%). In the study, it was noted that yeast extract stimulated the cell growth of *H. boliviensis*, but when used at a high concentration, reduced the PHB yield (Quillaguamán et al. 2007). This would suggest that certain nutrient(s) provided in the yeast extract supported the cell growth, and upon depletion of such nutrient(s) PHB accumulation was triggered.

The present study was undertaken to find strategies for improving the volumetric productivity of PHB by *H. boliviensis* using glucose as the carbon source. For this, it was considered important to determine the essential nitrogen source for the organism that would allow a better control of the supply of nutrients for optimal PHB production. Eventually, a fed-batch strategy was used to attain both high cell density and a suitable nutrient limitation mode that led to high polymer production.

Materials and methods

Bacterial strain and maintenance

H. boliviensis LC1^T (= DSM 15516^T) was maintained at 4°C on solid HM medium (Quillaguamán et al. 2004),

containing (% w/v) NaCl, 4.5; MgSO₄·7H₂O, 0.025; CaCl₂·2H₂O, 0.009; KCl, 0.05; NaBr, 0.006; peptone, 0.5; yeast extract, 1.0; glucose, 0.1; and granulated agar, 2.0. The pH of the medium was adjusted to 7.5 using 3 M NaOH.

Culture medium for PHB production

The culture medium used for PHB production by *H. boliviensis* was based on that reported previously for *Halomonas elongata* (Table 1; Sauer and Galinski 1998). Some components of the medium were varied in different experiments.

H. boliviensis growth and PHB production in flasks

H. boliviensis was grown in 10 ml of seed culture medium in 100-ml flasks with rotary shaking at 200 rpm, 30°C for 13 h. The medium was supplemented with 0.1% (w/v) of an amino acid, e.g., aspartic acid, glutamine, alanine, arginine, cysteine, tryptophan, or glycine. The pH of the medium was adjusted to 7.5 using concentrated HCl. Subsequently, 0.25 ml of each culture was inoculated in 250-ml Erlenmeyer flasks containing 25 ml of batch culture medium with 0.1% (w/v) of the corresponding amino acid (Table 1). The pH of this medium was initially adjusted to 7.5 using 5 M NaOH. The cultures were incubated at 30°C with shaking at 200 rpm, and samples were withdrawn at 30 h of cultivation.

The effect of different concentrations of NH₄Cl on induction of PHB synthesis was tested under similar conditions as above in a medium containing 0.1% (w/v) glutamine.

PHB production by fed-batch culture

H. boliviensis was first grown in 150 ml of seed culture medium (Table 1) supplemented with 0.3% (w/v) glutamine in 1,000-ml flasks incubated at 30°C with shaking at

Table 1 Media composition for PHB production by *H. boliviensis*

Component	Seed culture (g)	Batch (g)	Feed (g)
Glucose	10	20	700
NaCl	45	45	45
MgSO ₄ ·7H ₂ O	2.5	5	5
K ₂ HPO ₄	0.55	V	–
NH ₄ Cl	2.3	V	–
FeSO ₄ ·7H ₂ O	0.005	0.005	0.125
Amino acid	V	V	–
Tris	15	–	–

All components were dissolved in 1,000 ml water.

V: Component concentration was varied in different experiments

200 rpm for 15 h when the culture broth reached an optical density (OD_{600}) of 2.5–2.8. The culture broth was used to inoculate a 2-l fermentor vessel (Voyage, Luton, UK) containing 1.35 l of cultivation medium. In all cultivations, the medium was supplemented with 20 g l^{-1} monosodium glutamate (MSG) as the amino acid (Table 1). The pH of the medium was maintained at 7.5 using 5 M HCl/NaOH. Glucose concentration was monitored using off-line analysis and maintained at $20 (\pm 4) \text{ g l}^{-1}$ by adding the feed solution (Table 1) when a decrease in the glucose concentration was detected. The air inflow rate and agitation speed were initially adjusted to 0.8 l min^{-1} and 700 rpm and were increased when a decrease in the initial concentration of oxygen (i.e., 85%) was detected. The highest air inflow rate and agitation attained were 5 l min^{-1} and 1,100 rpm, respectively. Antifoam was added to the fermentor when needed. The effects of varying NH_4Cl , K_2HPO_4 , and MSG concentrations on cell dry weight (CDW) and PHB yield during fed-batch cultivation were studied.

Quantitative analyses

Cell dry weight and PHB content in *H. boliviensis* were determined as reported previously (Quillaguamán et al. 2007). All analyses were performed in triplicate.

Glucose concentration was analyzed by Accu-Chek sensors (Roche, Mannheim, Germany). Ammonium and phosphate concentrations were quantified using LCK-303 and LCK-349 Lange kits (Düsseldorf, Germany), respectively, according to the instructions given by the suppliers.

Glutamate concentration was determined by high-performance liquid chromatography (HPLC) analysis, as described previously (Onraedt et al. 2005), using a Perkin-Elmer HPLC system with an Aminex HPX-87C column (Biorad) and a UV detector at 65°C . Calcium chloride solution (5 mM) was used as mobile phase at a flow rate of 0.3 ml min^{-1} . The glutamate was monitored at 210 nm.

Results

H. boliviensis growth and PHB production in a defined medium

A preliminary study was initially done to determine the essential nitrogen source required for *H. boliviensis* growth. For this, the organism was grown by supplying individual amino acids to a minimal medium designed earlier for *H. elongata* (Table 1). Only three amino acids, i.e., aspartic acid, glycine, and glutamine, were found to induce *H. boliviensis* growth. As shown in Fig. 1a, addition of glutamine resulted in the highest CDW. At glutamine

concentration of 0.2% (w/v), CDW of 5.3 g l^{-1} was obtained, which was significantly higher than that (3.4 g l^{-1}) reached using 0.3% (w/v) yeast extract (Fig. 1a).

Subsequently, the effect of varying the initial NH_4Cl concentration on inducing PHB production was investigated using the medium containing 0.1% (w/v) glutamine. A maximum PHB content of 62 wt.% was attained using 0.15% (w/v) NH_4Cl , while further increase in NH_4Cl concentration of up to 0.3% (w/v) resulted in the lowering of the PHB content to 50 wt.% (Fig. 1b). The CDW in these cultivations was in the range of $2.6\text{--}4 \text{ g l}^{-1}$ after 30 h of growth (data not shown).

PHB production by *H. boliviensis* by cultivation in fed-batch mode

H. boliviensis was then cultivated in a fed-batch fermentation mode, and influence of NH_4Cl and K_2HPO_4 concentrations on cell growth and PHB production was analyzed. Glutamine was replaced by glutamate in the batch medium for these experiments. In all cases, the initial concentration of glutamate in the batch medium was 20 g l^{-1} and glucose concentration in the fermentor was kept approximately

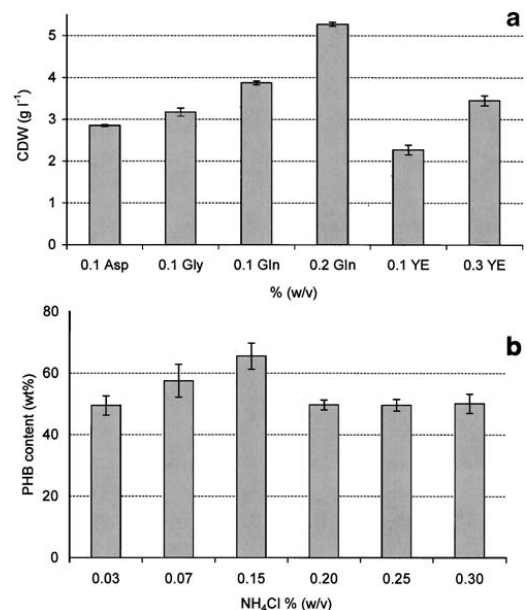

Fig. 1 Cell growth and PHB accumulation in *H. boliviensis* in batch culture (see Table 1 for medium composition). **a** Cell dry weight in batch supplemented with aspartic acid (*Asp*), glycine (*Gly*), glutamine (*Gln*), and yeast extract (*YE*). **b** Poly(3-hydroxybutyrate) production with 0.1% (w/v) glutamine and different concentrations of NH_4Cl . All cultivations were performed in shake flasks for 30 h at 30°C

constant at 20 g l^{-1} during the cultivation. At an initial concentration of 0.2% (w/v) NH_4Cl and 0.11% (w/v) K_2HPO_4 , increasing accumulation of PHB was noted after about 18 h of cultivation, and a maximum PHB content and CDW of $82 \text{ wt.}\%$ and 22 g l^{-1} , respectively, were reached after 28 h (Fig. 2a,b). On increasing the NH_4Cl concentration to 0.6% (w/v) while keeping K_2HPO_4 at 0.11% (w/v ; Fig. 2a,b), the rate of cell growth was seen to decrease and gave a CDW of 34 g l^{-1} after 35 h while the PHB content was decreased to $57 \text{ wt.}\%$. The latter experiment was repeated but now MSG was intermittently added to the fermentor at 6 and 9 h of cultivation (Fig. 2a,b). In this case, the rate of PHB accumulation was significantly improved and resulted in a maximal polymer content of $89 \text{ wt.}\%$ after 24 h of cultivation at which time the CDW obtained was 23 g l^{-1} . An additional experiment was performed using 0.4% (w/v) NH_4Cl and 0.22% (w/v) K_2HPO_4 and adding MSG intermittently as before. The maximum PHB content and CDW were similar to the last experiment (i.e., $90 \text{ wt.}\%$ and 23 g l^{-1} , respectively) but were achieved in a cultivation time of only 18 h (Fig. 2a,b).

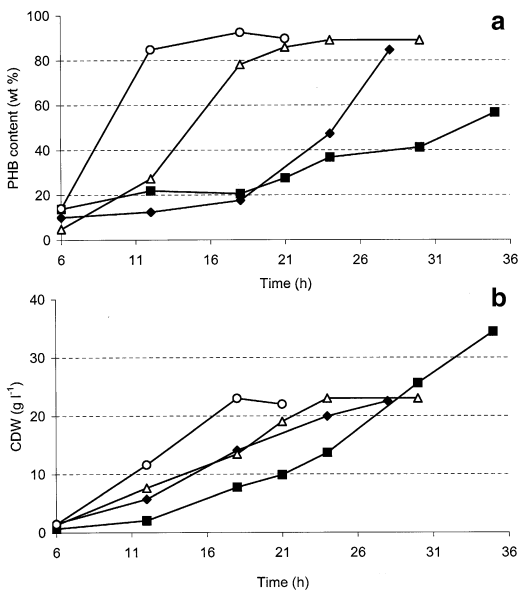

Fig. 2 Effect of addition of MSG and other nutrients on (a) PHB accumulation and (b) CDW of *H. boliviensis* in batch culture with glucose as carbon source. Symbols refer to the medium containing NH_4Cl and K_2HPO_4 at initial concentrations of 0.2% and 0.11% (w/v ; rhombuses), 0.6% and 0.11% (w/v ; squares), 0.6% and 0.11% (w/v ; triangles), and 0.4% and 0.22% (circles). Open symbols indicate that 10 ml MSG (250 g l^{-1}) was added after 6 and 9 h, respectively, whereas closed symbols indicate that MSG was not added during the cultivation

Optimizing conditions for PHB production by *H. boliviensis*

In order to increase the cell density further and, hence, the volumetric productivity of the polymer by *H. boliviensis* in the medium using 0.4% (w/v) NH_4Cl and 0.22% (w/v) K_2HPO_4 , the two salts were added to the fermentor to avoid an early nutrient limitation. For this, a solution containing 12.2% (w/v) NH_4Cl and 27% (w/v) K_2HPO_4 was fed to the fermentor at 3rd (4 ml), 6th (1 ml), 9th (1 ml), and 12th (3 ml) hours of cultivation. Furthermore, 25% (w/v) MSG was intermittently added to maintain the initial concentration (20% (w/v)) constant during the first 9 h with the help of an HPLC off-line analysis. The CDW was improved about twofold to 44 g l^{-1} , and a maximum PHB content of $81 \text{ wt.}\%$ was reached after 33 h of cultivation (Fig. 3). Poly (3-hydroxybutyrate) synthesis was initiated when both MSG and NH_4^+ were being depleted from the medium. Moreover, PO_4^{3-} concentration decreased slightly during the first 6 h and increased again to its initial concentration after 9 h of cultivation (data not shown). It was also observed that excess of glutamate or NH_4^+ during the PHB synthesis increases the CDW but reduces the PHB content and prolongs the production time (data not shown).

Discussion

Earlier studies on PHB production by *H. boliviensis* suggested the need for developing a new culture medium and cultivation strategy in order to achieve increased volumetric productivity (Quillaguamán et al. 2007). The use of a complex nitrogen source such as yeast extract

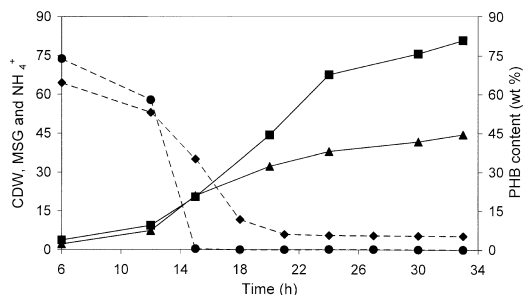

Fig. 3 Fed-batch culture of *H. boliviensis* with glucose as carbon source. The different symbols refer to MSG concentration (10 l^{-1} ; circles), ammonium concentration (50 l^{-1} ; rhombuses), PHB content (squares), and CDW (g l^{-1} ; triangles). Initial glucose concentration (20 g l^{-1}) was kept constant during the cultivation. Monosodium glutamate (250 g l^{-1}) was added intermittently to keep its concentration constant during the first 9 h. The results shown are the average of the samples taken from three experiments. The samples for each experiment were analyzed in duplicates

Table 2 PHB production in fed-batch cultivation of *H. boliviensis* and other bacterial species regarded to hold potential for industrial application

Organism	Carbon source	PHB content (wt.%)	CDW (g l^{-1})	PHB concentration (g l^{-1})	Volumetric productivity ($\text{g l}^{-1} \text{h}^{-1}$)	Reference
<i>Halomonas boliviensis</i>	Glucose	81.0	44.0	35.4	1.10	This work
<i>Alcaligenes latus</i>	Sucrose	88.0	111.7	98.7	4.94	Wang and Lee (1997)
<i>Escherichia coli</i>	Glucose	73.0	194.1	141.7	4.63	Choi et al. (1998)
<i>Cupriavidus necator</i>	Glucose	76.0	164.0	121.0	2.42	Kim et al. (1994)
<i>C. necator</i>	CO ₂	67.8	91.3	61.9	1.55	Tanaka et al. (1995)
<i>Azotobacter vinelandii</i>	Glucose	79.8	40.1	32.0	0.68	Page and Cornish (1993)
<i>Pseudomonas extorquens</i>	Methanol	64.0	233.0	149.0	0.88	Suzuki et al. (1986)

makes it difficult to control the supply of nutrients for achieving high cell density as well as optimal PHB productivity. In this work, a defined medium was formulated and sequentially optimized for PHB production through fed-batch cultures by *H. boliviensis*.

The growth of *H. boliviensis* was observed only when aspartic acid, glycine, or glutamine were supplied to a minimum medium (Fig. 1a). These amino acids are essential cell components and are precursors for the synthesis of other amino acids (i.e., glutamine and aspartic acid) and DNA components (i.e., glycine) in bacteria. Although glutamine led to the highest cell growth (Fig. 1a), its use as a nutrient would have limitations because of its poor aqueous solubility and high costs. Hence, it was subsequently replaced by MSG without showing any difference in the final cell concentration. Glutamine can be synthesized from glutamate in one step by the action of glutamine synthase. Monosodium glutamate is obtained in large amounts from renewable sources, e.g., from crops or by fermentation of starch, sugar beets, sugar cane, or molasses (Ault 2004). Pure MSG is at least five times cheaper than yeast extract and much cheaper when distributed as bulk chemical. Replacing yeast extract with MSG in the medium will thus lead to a drastic reduction in the medium costs.

Limitation of a nitrogen or a phosphorous source is required to achieve the maximum volumetric productivities by the best bacterial PHB producers in fed-batch systems (Kim et al. 1994; Wang and Lee 1997; Choi et al. 1998). *H. boliviensis* produces the PHB during its stationary phase of growth, hence denoting that depletion of an essential nutrient in the culture medium would initiate the polymer accumulation in the cells (Quillaguamán et al. 2006). In this respect, limitation of the nitrogen source (NH₄Cl) was first examined in shake flasks (Fig. 2b). Use of an appropriate concentration of NH₄Cl led to a maximum PHB content of 62 wt.% that was higher than that (55 wt.%) obtained using yeast extract as the nitrogen source (Quillaguamán et al. 2006).

The effect of NH₄Cl was analyzed using a fed-batch cultivation mode as well. Thus, starting from an initial

concentration of 0.2% (w/v) NH₄Cl, the PHB yield attained was improved to 82 wt.%. Increasing the concentration of NH₄Cl to 0.6% (w/v) resulted in inhibition of cell growth (Fig. 2b) and also a drastic decrease in PHB implying that excess of the salt was not suitable for PHB accumulation (Fig. 2a). Nevertheless, a step-wise addition of MSG during the cultivation enhanced cell growth, which in turn led to a faster consumption of NH₄Cl and hence increased PHB production rate and yield (89 wt.%). Reducing the initial NH₄Cl concentration to 0.4% (w/v) increased further the rate of PHB production (Fig. 2a). This indicated that a combined effect of NH₄Cl and MSG was to be considered for obtaining high cell density and an efficient PHB production by *H. boliviensis*.

In subsequent experiments, *H. boliviensis* cell growth was favored during the first hours of cultivation by adding solutions of NH₄Cl, K₂HPO₄, and MSG to the fermentor in order to avoid early nutrient depletion. Poly(3-hydroxybutyrate) accumulation was then promoted by suppressing the feed of these salts. It was observed that high PHB synthesis was accelerated when lack of both MSG and NH₄Cl in the medium limited the cell growth (Fig. 3). The phosphate levels, on the other hand, did not show much variation (except for a slight decrease during the initial hours of cultivation because of consumption by the growing cells), indicating that this salt does not have a determining role in the PHB accumulation.

The volumetric productivity and PHB yield obtained under the above conditions by *H. boliviensis* are comparable to that of the highest producers reported so far (Table 2). They are in the same range as that reached by *A. vinelandii*, albeit further improvements in cell density and productivity are still needed to achieve the PHB production levels reported with *A. latus* and recombinant *E. coli* (Table 2). Nonetheless, this work places *H. boliviensis* as a new and attractive option for production of the polyester, which is gaining a considerable relevance in the market of biomaterials.

Further work on improving PHB production by *H. boliviensis* is being performed by using online monitoring and control of carbon and nitrogen sources during the fermentation process.

Acknowledgement The authors would like to thank the Swedish International Development Cooperation Agency (Sida) for supporting this work.

References

- Ault A (2004) The monosodium glutamate story: the commercial production of MSG and other amino acids. *J Chem Educ* 81:347–355
- Choi J, Lee SY (1999) Factors affecting the economics of polyhydroxyalkanoate production by bacterial fermentation. *Appl Microbiol Biotechnol* 51:13–21
- Choi J, Lee SY, Han K (1998) Cloning of the *Alcaligenes latus* polyhydroxyalkanoate biosynthesis genes and use of these genes for enhanced production of poly(3-hydroxybutyrate) in *Escherichia coli*. *Appl Microbiol Biotechnol* 64:4897–4903
- Freier T, Sternberg K, Behrend D, Schmitz KP (2005) Health issues of biopolymers: polyhydroxybutyrate. In: Steinbüchel A, Marchessault RH (eds) *Biopolymers for medical and pharmaceutical applications*. Wiley, Weinheim, pp 1049–1082
- Kim BS, Lee SC, Lee SY, Chang HN, Chang YK, Woo SI (1994) Production of poly(3-hydroxybutyric acid) by fed-batch culture of *Alcaligenes eutrophus* with glucose concentration control. *Biotechnol Bioeng* 43:892–898
- Lee SY (1996) Plastic bacteria? Progress and prospects for polyhydroxyalkanoate production in bacteria. *Trends Biotechnol* 14:431–438
- Lemoigne M (1926) Products of dehydration and of polymerization of b-hydroxybutyric acid. *Bull Soc Chim Biol* 8:770–782
- Onraedt AE, Wlarius BA, Soetaert WK, Vandamme EJ (2005) Optimization of ectoine synthesis through fed-batch fermentation of *Brevibacterium epidermis*. *Biotechnol Prog* 21:1206–1212
- Page WJ, Cornish A (1993) Growth of *Azotobacter vinelandii* UWD in fish peptone medium and simplified extraction of poly-b-hydroxybutyrate. *Appl Environ Microbiol* 59:4236–4244
- Philip S, Keshaverz T, Roy I (2007) Polyhydroxyalkanoates: biodegradable polymers with a range of applications. *J Chem Technol Biotechnol* 82:233–247
- Quillaguamán J, Delgado O, Mattiasson B, Hatti-Kaul R (2006) Poly(b-hydroxybutyrate) production by a moderate halophile, *Halomonas boliviensis* LC1. *Enzyme Microb Technol* 38:148–154
- Quillaguamán J, Hashim S, Bento F, Mattiasson B, Hatti-Kaul R (2005) Poly(b-hydroxybutyrate) production by a moderate halophile, *Halomonas boliviensis* LC1 using starch hydrolysate as substrate. *J Appl Microbiol* 99:151–157
- Quillaguamán J, Hatti-Kaul R, Mattiasson B, Alvarez MT, Delgado O (2004) *Halomonas boliviensis* sp. nov., an alkalitolerant, moderate halophile bacterium isolated from soil around a Bolivian hypersaline lake. *Int J Syst Evol Microbiol* 54:721–725
- Quillaguamán J, Muñoz M, Mattiasson B, Hatti-Kaul R (2007) Optimising conditions for poly(b-hydroxybutyrate) production by *Halomonas boliviensis* LC1 in batch culture with sucrose as carbon source. *Appl Microbiol Biotechnol* 74:981–986
- Reddy CSK, Ghai R, Kalia V (2003) Polyhydroxyalkanoates: an overview. *Bioresour Technol* 87:137–146
- Rodriguez-Valera F, Lillo JAG (1992) Halobacteria as producers of polyhydroxyalkanoates. *FEMS Microbiol Rev* 103:181–186
- Sauer T, Galinski EA (1998) Bacterial milking: a novel bioprocess for production of compatible solutes. *Biotechnol Bioeng* 57:306–313
- Steinbüchel A, Fuchtenbush B (1998) Bacterial and other biological systems for polyester production. *Trends Biotechnol* 16:419–427
- Suzuki T, Yamane T, Shimizu S (1986) Mass production of poly-b-hydroxybutyric acid by fed-batch culture with controlled carbon/nitrogen feeding. *Appl Microbiol Biotechnol* 24:370–374
- Tanaka K, Ishizaki A, Kanamaru T, Kawano T (1995) Production of poly(D-3-hydroxybutyrate) from CO₂, H₂ and O₂ by high cell density autotrophic cultivation of *Alcaligenes eutrophus*. *Biotechnol Bioeng* 45:268–275
- Wang F, Lee SY (1997) Poly(3-hydroxybutyrate) production with high productivity and high polymer content by a fed-batch culture of *Alcaligenes latus* under nitrogen limitation. *Appl Environ Microbiol* 63:3703–3706
- Williams SF, Martin DP (2005) Applications of PHAs in medicine and pharmacy. In: Steinbüchel A, Marchessault RH (eds) *Biopolymers for medical and pharmaceutical applications*. Wiley, Weinheim, pp 89–125

III

A process for the production of ectoine and poly(3-hydroxybutyrate) by *Halomonas boliviensis*

Héctor Guzmán · Doan Van-Thuoc · Javier Martín ·
Rajni Hatti-Kaul · Jorge Quillaguamán

Received: 14 January 2009 / Revised: 23 April 2009 / Accepted: 4 May 2009 / Published online: 23 May 2009
© Springer-Verlag 2009

Abstract The paper reports a study involving the use of *Halomonas boliviensis*, a moderate halophile, for co-production of compatible solute ectoine and biopolyester poly(3-hydroxybutyrate) (PHB) in a process comprising two fed-batch cultures. Initial investigations on the growth of the organism in a medium with varying NaCl concentrations showed the highest level of intracellular accumulation of ectoine (0.74 g L^{-1}) at 10–15% (*w/v*) NaCl, while at 15% (*w/v*) NaCl, the presence of hydroxyectoine (50 mg L^{-1}) was also noted. On the other hand, the maximum cell dry weight and PHB concentration of 10 and 5.8 g L^{-1} , respectively, were obtained at 5–7.5% (*w/v*) NaCl. A process comprising two fed-batch cultivations was developed—the first culture aimed at obtaining high cell mass and the second for achieving high yields of ectoine and PHB. In the first fed-batch culture, *H. boliviensis* was grown in a medium with 4.5% (*w/v*) NaCl and sufficient levels of monosodium glutamate, NH_4^+ , and PO_4^{3-} . In the second fed-batch culture, the NaCl concentration was increased to 7.5% (*w/v*) to trigger ectoine synthesis, while nitrogen and phosphorus sources were fed only during the first 3 h and

then stopped to favor PHB accumulation. The process resulted in PHB yield of 68.5 wt.% of cell dry weight and volumetric productivity of about $1 \text{ g L}^{-1} \text{ h}^{-1}$ and ectoine concentration, content, and volumetric productivity of 4.3 g L^{-1} , 7.2 wt.%, and $2.8 \text{ g L}^{-1} \text{ day}^{-1}$, respectively. At salt concentration of 12.5% (*w/v*) during the second cultivation, the ectoine content was increased to 17 wt.% and productivity to $3.4 \text{ g L}^{-1} \text{ day}^{-1}$.

Keywords Moderate halophile · *Halomonas boliviensis* · Compatible solutes · Poly(3-hydroxybutyrate) · Fed-batch cultivation

Introduction

Microorganisms that grow in environments with moderate or high salt concentrations are known to produce a variety of metabolites primarily as a means of adaptation to their environment (Oren 2002). Moderate halophilic and halotolerant microorganisms are able to grow at high salt concentrations (15–30% *w/v*) by counteracting the salt stress through intracellular accumulation of osmolytes, also called “compatible solutes”, to achieve osmotic equilibrium with respect to the salts in the surrounding environment (Kunte et al. 1993; Roberts 2005; Lentzen and Schwarz 2006).

Compatible solutes can be zwitterionic, noncharged, or anionic and are represented by various classes of organic compounds including polyols, sugars, amino acids, betaines, ectoines and their derivatives, among others (Roberts 2005; Lentzen and Schwarz 2006). In general, they are usually low molecular weight compounds and are highly water-soluble allowing their accumulation in high concentrations in the cytoplasm. Zero net charge of the compounds is an

H. Guzmán · D. Van-Thuoc · J. Martín · R. Hatti-Kaul ·
J. Quillaguamán
Department of Biotechnology, Lund University,
P.O. Box 124, 221 00 Lund, Sweden

H. Guzmán · J. Quillaguamán (✉)
Centro de Biotecnología, Facultad de Ciencias y Tecnología,
Universidad Mayor de San Simón,
Cochabamba, Bolivia
e-mail: jorgeqs@supernet.com.bo

D. Van-Thuoc
Department of Micro-biotechnology, Faculty of Agro-Biology,
Hanoi National University of Education,
136 Xuan Thuy, Cau Giay,
Hanoi, Vietnam

advantage as they can be accumulated without a counterion (Galinski 1993). Among the zwitterionic osmolytes, ectoines (ectoine and its hydroxy derivative, hydroxyectoine) have gained much attention in biotechnology as protective agents for enzymes, DNA, and whole cells against stresses such as freezing, drying, and heating (Lippert and Galinski 1992; Louis et al. 1994; Welsh 2000). The cryoprotective properties of these compounds make them interesting for increasing the stability and freshness of foods by stabilizing food components with potential health benefits (Lentzen and Schwarz 2006). Ectoines also find applications as moisturizers in cosmetics or skin care products (Sauer and Galinski 1998; Lentzen and Schwarz 2006; Vargas et al. 2006).

Ectoines are currently produced on a large scale using the moderate halophilic bacterium *Halomonas elongata* (=DSM 142^T) in a process called bacterial milking, which consists of fed-batch cultivation of the organism at 15% (w/v) NaCl for accumulation of ectoines, followed by concentration of cell broth by membrane filtration, and ectoines release from the cells by hypoosmotic shock (Sauer and Galinski 1998). The cells are then re-suspended in a new culture medium to start a new process cycle. Fed-batch cultures of *Brevibacterium epidermis* (=DSM 20659) and transgenic *Escherichia coli* (containing ectoine genes of the halophilic bacterium *Chromohalobacter salexigens*) have also resulted in high ectoine productivity and yields (Onraedt et al. 2005; Schubert et al. 2007). In the latter case, most of the ectoine is excreted into the medium.

In our earlier reports, we have demonstrated the potential of a moderate halophile, *Halomonas boliviensis*, for the production of biopolyester, poly(3-hydroxybutyrate) (PHB; Quillaguamán et al. 2005, 2008). PHB resembles the common petrochemical-based synthetic thermoplastics, polyethylene and polypropylene, with respect to mechanical properties, but differs in being biodegradable, biocompatible, and nontoxic (Reddy et al. 2003). PHB has found applications as disposable plastic for bottles, containers, packing materials, adhesives, and also for medical and pharmaceutical devices (Lee 1996; Philip et al. 2007). High PHB yields up to 81 wt.% were achieved by cultivating

H. boliviensis in a fed-batch mode and under conditions of nitrogen limitation (Quillaguamán et al. 2008). Our earlier studies indicated that the yield of the polymer was not affected by the salt concentration in the medium up to at least 15% (w/v) NaCl; however, the synthesis was significantly delayed at NaCl concentrations of $\geq 9\%$ (w/v), which was suggested to be due to the synthesis of osmolytes, an energetically expensive metabolic pathway for cells (Quillaguamán et al. 2006).

This report presents an investigation on the nature of compatible solutes accumulated by *H. boliviensis*, culture conditions required for their optimal production, and further describes a strategy used for the combined production of PHB and the osmolytes. A study on the co-production of the biopolyester and ectoine by *H. elongata* has been published very recently (Mothes et al. 2008).

Materials and methods

Bacterial strain and maintenance

H. boliviensis LC1^T (=DSM 15516^T) was maintained at 4°C on solid HM medium (Quillaguamán et al. 2004), containing (per liter): 45 g NaCl, 0.25 g MgSO₄·7H₂O, 0.09 g CaCl₂·2H₂O, 0.5 g KCl, 0.06 g NaBr, 5 g peptone, 10 g yeast extract, 1 g glucose, and 20 g granulated agar. The pH of the medium was adjusted to 7.5 using 3 M NaOH.

Shake flask cultivations of *H. boliviensis* for production of compatible solute and biopolyester

The composition of the culture media used in this study is described in Table 1 and was based on a medium designed for *H. elongata* (Sauer and Galinski 1998). Glucose and monosodium glutamate were sterilized separately. The pH of the medium was adjusted to 7.5 using concentrated HCl or 5 M NaOH.

H. boliviensis was grown in 100 mL seed culture medium (Table 1) in 1 L Erlenmeyer flasks at 30°C and 200 rpm in a

Table 1 Composition of the culture media used for production of ectoines and PHB by *H. boliviensis*

Component	Seed culture (g L ⁻¹)	Batch (g L ⁻¹)	Feed (g L ⁻¹)
Glucose	10	20	700
NaCl	45	V	V
MgSO ₄ ·7H ₂ O	2.5	5	5
NH ₄ Cl	2.3	4.5	4.5
K ₂ HPO ₄	0.55	1.1	1.1
FeSO ₄ ·7H ₂ O	0.005	0.01	0.01
Tris	15	–	–
Glutamine	1	–	–
Monosodium glutamate	–	20	–

V variable concentration

rotary shaker incubator (New Brunswick Scientific, NJ, USA) for 13 h. Subsequently, 1 mL of the culture was inoculated in 1 L Erlenmeyer flasks containing 100 mL of batch culture medium with 45 g L⁻¹ NaCl and 20 g L⁻¹ glutamate (instead of glutamine; Table 1), and cultivation was performed under similar conditions as stated above. After 13 h of growth, cells were centrifuged at 6,000×g for 15 min, suspended in 100 mL batch medium with varying NaCl concentrations, and transferred to 1 L Erlenmeyer flasks for further cultivation. Samples were withdrawn every 12 h for analyses.

Production of compatible solute by two-step fed-batch cultures

H. boliviensis was first grown in 100 mL of seed culture medium in a 1-L flask at 30°C and 200 rpm for 13 h. The culture broth was used to inoculate 1.4 L of batch cultivation medium with 45 g L⁻¹ NaCl in a 2-L bioreactor (Voyager, Luton, UK). A feed with glucose concentration of 700 g L⁻¹ was used (Table 1) for maintaining the concentration of carbon source at 20 g L⁻¹ in the bioreactor. After 21 h, cells were harvested from the culture medium by centrifugation at 6,000×g for 10 min and used to inoculate a batch medium for the second fed-batch culture, containing higher NaCl concentrations (either 75 or 125 g L⁻¹ NaCl), in order to trigger the synthesis of compatible solutes. The concentration of NaCl in the feed solution was modified accordingly.

Temperature during the cultivations was maintained at 35°C while pH was kept constant at 7.5 using 5 M HCl/NaOH. Stirring velocity and aeration were initially set at 700 rpm and 1 L min⁻¹ and increased when a decrease in the initial concentration of oxygen (i.e., 80%) was detected. The highest agitation and air inflow rate used were 1,100 rpm and 5 L min⁻¹, respectively. Glucose concentration in the medium was monitored by off-line analysis and maintained at about 20 g L⁻¹ by adding the feed solution when a decrease in the glucose concentration was detected. Polypropylene glycol 2025 was added as antifoam when required.

Combined production of compatible solute and biopolyester in a two-step fed-batch culture

The composition of the culture media used for cultivation of *H. boliviensis* was modified to obtain high cell density and to promote PHB synthesis. Glutamine concentration in the seed culture medium was increased to 3 g L⁻¹. The first fed-batch cultivation was run for 15 h using a glucose feed. NH₄Cl and K₂HPO₄ were not included in the feed; instead, a solution of 390 g L⁻¹ NH₄Cl and 500 g L⁻¹ K₂HPO₄ was added every 3 h to the bioreactor to maintain NH₄⁺

and PO₄³⁻ at the initial concentrations in the fermentor. Glucose concentration in the bioreactor was kept constant as indicated above. Glutamate concentration in the medium was followed by off-line analysis on high-performance liquid chromatography (HPLC) and maintained at 20 g L⁻¹ by adding a 250 g L⁻¹ monosodium glutamate solution when a decrease in the concentration was noted.

After the first fed-batch culture, cells were harvested as above and were transferred to a bioreactor containing the batch medium with 75 g L⁻¹ NaCl. For the second fed-batch culture, monosodium glutamate, NH₄Cl, and K₂HPO₄ were added to the bioreactor until the third hour of cultivation in order to reconstitute the initial concentrations so as to avoid nutrient limitation at an early stage. Thereafter, the addition of these nutrients was stopped.

Settings for both fed-batch cultures were adjusted as described above. Samples for determination of PHB and compatible solutes were taken every 3 h until optical density at 600 nm (OD₆₀₀) was approximately constant.

Extraction of compatible solutes

H. boliviensis cells were permeabilized by hypoosmotic shock using water for extraction of compatible solutes (Schiraldi et al. 2006). Cells from 0.5 to 1 mL of fermentation broth were harvested by centrifugation (10,000×g, 5 min) and re-suspended in 1 mL of H₂O. The suspension was allowed to stand for 0.5–2 h at room temperature prior to centrifugation and analysis of the osmolyte concentration in the cell-free supernatant.

Analytical methods

All analyses were performed in triplicates. The cell dry weight (CDW) and PHB concentration of *H. boliviensis* were determined as reported previously (Quillaguamán et al. 2007). PHB content (weight percent) was obtained as the percentage of the ratio of PHB concentration to cell dry weight, while residual cell mass (RCM) was calculated as the difference between CDW and PHB concentration as defined by Lee et al. (2000).

Glucose concentration was analyzed by Accu-Chek sensors (Roche, Mannheim, Germany). Ammonium and phosphate concentrations were quantified using LCK-303 and LCK-349 Lange kits (Düsseldorf, Germany), respectively, according to the instructions provided by the suppliers.

The concentrations of the compatible solutes and monosodium glutamate were determined by HPLC analysis (Onraedt et al. 2005), using a Perkin-Elmer HPLC system with an Aminex HPX-87C column (Biorad) and a UV detector at 65°C. Calcium chloride (5 mM) was used as mobile phase at a flow rate of 0.3 mL min⁻¹. The compounds were monitored at 210 nm. The compatible solutes were

extracted from the cells according to a procedure reported earlier (Kunte et al. 1993). Ectoine content (weight percent) was calculated as the ratio of ectoine concentration to cell dry weight.

The chemical structure of the compatible solutes accumulated in *H. boliviensis* was determined by proton nuclear magnetic resonance ($^1\text{H-NMR}$) analysis. For this, *H. boliviensis* was grown in shake flasks at different NaCl concentrations for 48 h. Cells were harvested by centrifugation ($10,000\times g$, 10 min) and lyophilized. The compatible solutes were extracted from the lyophilized cells as reported previously (Kunte et al. 1993) and were also lyophilized.

Fifteen milligrams of the freeze-dried sample was dissolved in 0.75 ml of D_2O for $^1\text{H-NMR}$ analysis on a Bruker DRX-400 NMR spectrometer (^1H 400 MHz).

Results

Effect of salt concentration on accumulation of compatible solutes and PHB by *H. boliviensis*

H. boliviensis was grown at different NaCl concentrations (5–15% w/v) in shake flasks to investigate the effect of the

Fig. 1 $^1\text{H-NMR}$ spectra of whole-cell compatible solute extracts of *H. boliviensis* grown at: **a** 7.5% (w/v) NaCl and **b** 15% (w/v) NaCl, with signals from ectoine (*E*) and hydroxyectoine (*EOH*)

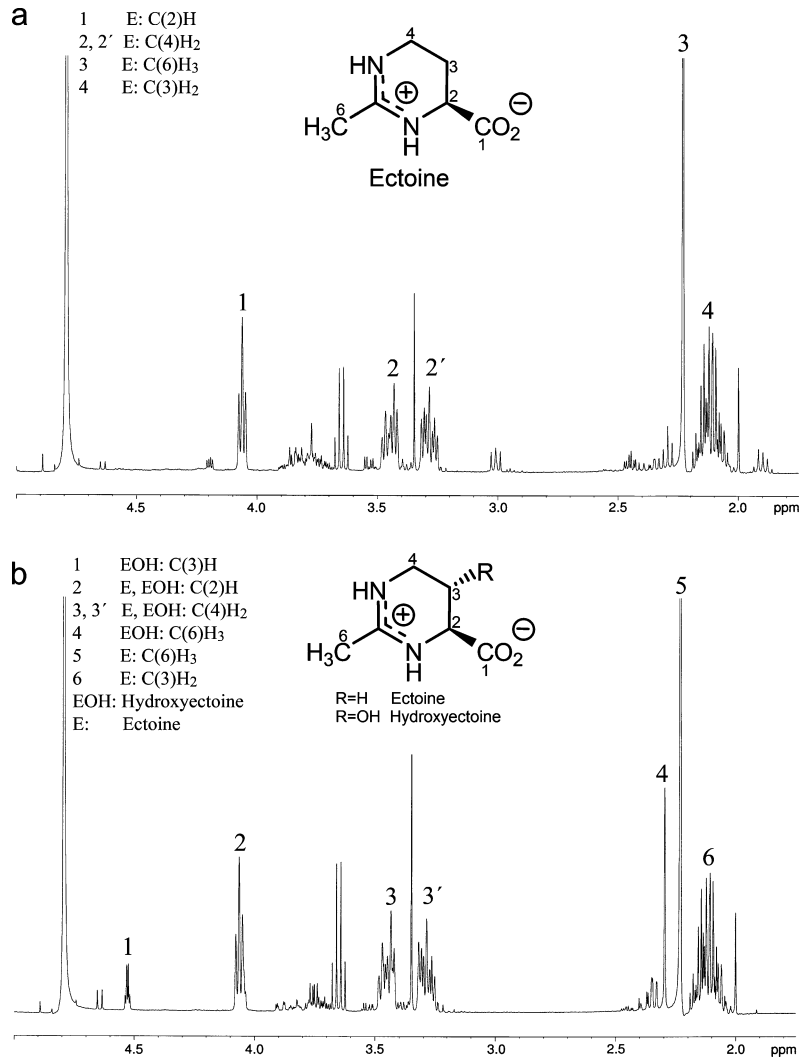

salt on accumulation of compatible solutes and PHB. The chemical structure of the osmolytes accumulated by the cells was determined by $^1\text{H-NMR}$ analysis (Fig. 1a). The proton signals and chemical shifts of the molecules formed in all salt concentrations corresponded to those for ectoine (Motta et al. 2004; Xu et al. 2001), while at NaCl concentrations $\geq 10\%$ (w/v), the presence of hydroxyectoine was also detected (Fig. 1a, b). The maximum ectoine concentration of 0.74 g L^{-1} was achieved after 36 h of cultivation at NaCl concentration of 10–15% (w/v; Fig. 2a). Hydroxyectoine reached a maximum concentration of 50 mg L^{-1} at 15% (w/v) NaCl (Fig. 2b).

In contrast, lower (5–7.5% w/v) concentrations of NaCl favored cell growth and biopolyester accumulation; the highest cell dry weight and PHB concentration obtained were 10 and 5.8 g L^{-1} , respectively (Fig. 2c, d).

Production of ectoine by two-step fed-batch system

The production of ectoine was then studied by fed-batch cultivation, and the process was divided into two cultivation stages for production of biomass and ectoine synthesis, respectively. The first cultivation at 4.5% (w/v) NaCl was stopped after 21 h when the cell dry weight reached was

$10.7 \pm 0.5 \text{ g L}^{-1}$. Subsequently, the cells were transferred to a fresh batch medium containing 7.5% and 12.5% (w/v) NaCl, respectively, for further growth in a second fed-batch culture. The cell dry weight obtained after 24 h of growth was 61.1 g L^{-1} at 7.5% (w/v) NaCl and 34.4 g L^{-1} at 12.5% NaCl. Ectoine concentration of about $5.5\text{--}5.7 \text{ g L}^{-1}$ was reached after 18 h of growth at both salt concentrations. The intracellular ectoine content showed only a slight increase from 9 to 10.6 wt.% cell dry weight within 6 h at 7.5% NaCl followed by a decrease to 8.4 wt.% until 24 h, while at 12.5% (w/v) NaCl, the ectoine content increased from 9.9 wt.% to a maximum of 17.0 wt.% cell dry weight after 18 h of cultivation, giving a total volumetric productivity of $3.4 \text{ g L}^{-1} \text{ day}^{-1}$ (Fig. 3a). Furthermore, 870 mg L^{-1} hydroxyectoine was obtained after 24 h at 12.5% (w/v) NaCl, while no hydroxyectoine was detected at 7.5% (w/v) NaCl in the medium (data not shown).

The cells grown for 24 h in the medium with 7.5% (w/v) NaCl were harvested and suspended in water for 30, 60, and 90 min, respectively, for testing extraction of the ectoines. Incubation for 30 min was found to be sufficient to release 95% of the ectoine from the cells.

PHB accumulation in the cells was also followed during the cultivations. The amount of PHB accumulated after the

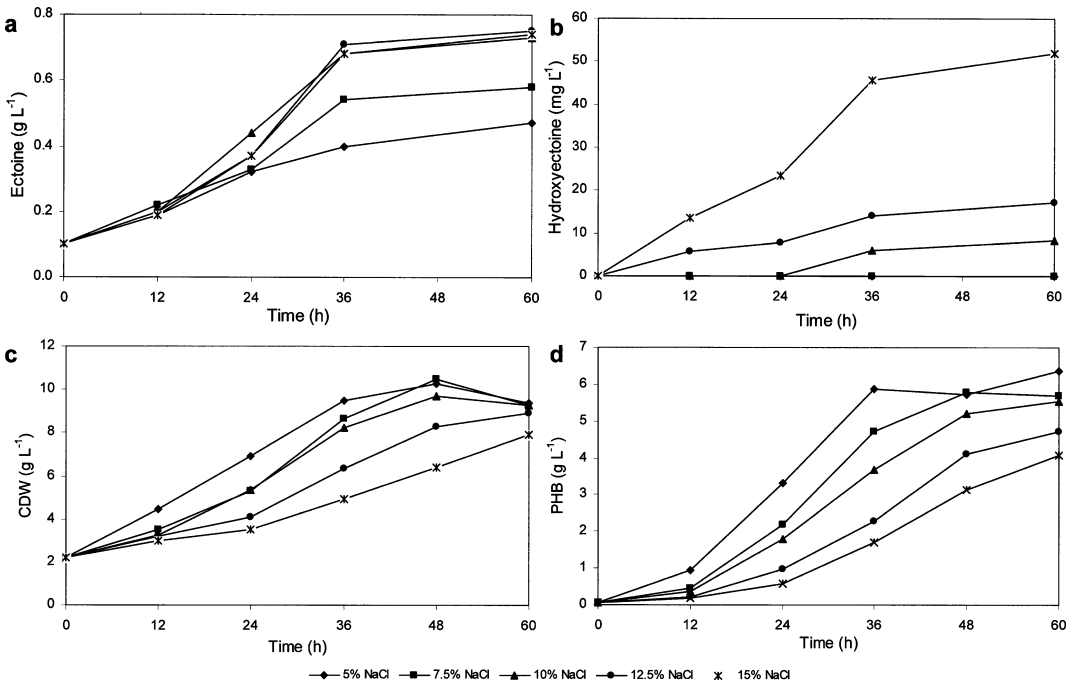

Fig. 2 Effect of sodium chloride concentration on **a** ectoine concentration, **b** hydroxyectoine concentration, **c** cell dry weight (CDW), and **d** PHB concentration in *H. boliviensis* grown in shake flasks at 200 rpm and 30°C

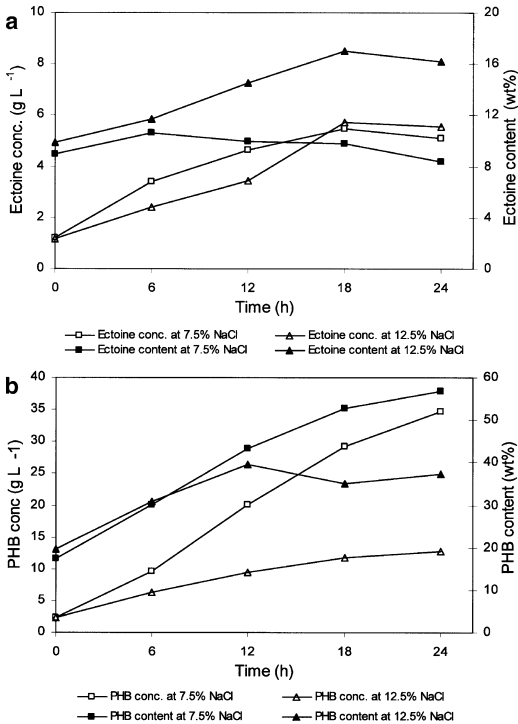

Fig. 3 Effect of NaCl concentration on **a** ectoine content and ectoine concentration and **b** PHB content and PHB concentration, by *H. boliviensis* during the second step fed-batch fermentation. The culture medium was inoculated with cells obtained from a previous fed-batch culture grown at 4.5% (*w/v*) NaCl for 21 h

first fed-batch cultivation was about 17–20 wt.% cell dry weight. During the second fed-batch culture, PHB synthesis continued for 24 h in the medium with 7.5% (*w/v*) to reach maximum polymer content of 56.7 wt.% and concentration of 34.7 g L⁻¹. At 12.5% (*w/v*) NaCl, the maximum PHB content obtained was 39.6 wt.% after 12 h of cultivation (Fig. 3b).

Combining the ectoine and PHB production

The first fed-batch cultivation was modified to avoid any limitation of the nitrogen source to investigate if the cell density could be further improved. Monosodium glutamate, NH₄Cl, and K₂HPO₄ were supplied to the bioreactor to maintain their concentrations at initial values during the first 15 h of cultivation. Under these conditions, the cell dry weight attained was 11.7 g L⁻¹ which accumulated 8.9 wt.% PHB and 8.4 wt.% ectoine.

During the second fed-batch step with 7.5% (*w/v*) NaCl in the medium, glutamate, NH₄Cl, and K₂HPO₄ were

maintained at constant levels during the first 3 h of cultivation to avoid nutrient limitation at an early stage. Subsequently, the supply of these nutrients was stopped. As shown in Fig. 4a, glutamate and NH₄Cl were totally consumed within 12 h. The phosphate level did not show much variation except for a slight decrease during the early phase of cultivation (not shown). PHB and ectoine production rates increased for 21–24 h and then decreased gradually (Fig. 4a, b). The cell density increased to 62 g L⁻¹ and PHB content to 68.5 wt.% in 24 h (Fig. 4a). The maximum ectoine content obtained was 13.2 wt.% within 6 h of cultivation and subsequently decreased to 6.1 wt.% in 24 h (data not shown). However, the maximum concentration of ectoine reached was 4.3 g L⁻¹ after 24 h (Fig. 4b), which was slightly reduced with respect to the previous fed-batch cultivations (Fig. 3b). Figure 4b further shows that production of ectoine is accompanied by an increase in the residual cell mass of *H. boliviensis*. In contrast, most PHB is synthesized when the residual cell mass is constant (Fig. 4b).

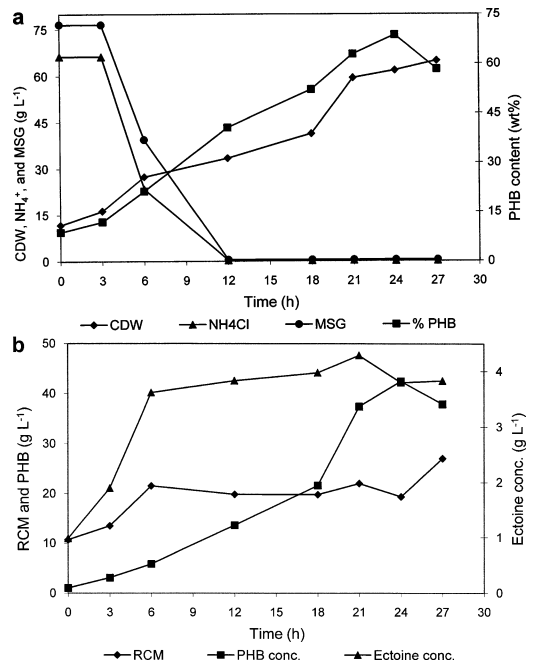

Fig. 4 Combined production of PHB and ectoine by *H. boliviensis* during the second step fed-batch fermentation. **a** CDW (gram per liter), NH₄⁺ (40 g L⁻¹), and glutamate (4 g L⁻¹); **b** RCM and PHB and ectoine concentrations (g L⁻¹). The culture medium was inoculated with cells obtained from the first fed-batch culture grown for 15 h at 4.5% (*w/v*) NaCl and maintaining the levels of monosodium glutamate, NH₄⁺, and PO₄³⁻ constant to avoid nutrient limitation

Taking into account the total production time of 15 h for the first fed-batch, 1 h for harvesting and re-suspending the cells, and 24 h for the second fed-batch culture, the PHB volumetric productivity was $1.06 \text{ g L}^{-1} \text{ h}^{-1}$. On the other hand, the maximum ectoine productivity of about $4 \text{ g L}^{-1} \text{ day}^{-1}$ was reached after 6 h which decreased to $2.8 \text{ g L}^{-1} \text{ day}^{-1}$ after 21 h.

Discussion

H. boliviensis is able to grow at a wide range of salt concentration (up to 25% NaCl); however, the cell growth is negatively influenced with increase in NaCl concentration beyond 4.5% w/v (Quillaguamán et al. 2004). Initial experiments performed in shake flasks showed that ectoine and hydroxyectoine are synthesized by the organism, with increase in salinity of the medium (Fig. 2). Such osmolytes are common among *Halomonas* spp. and are also found in other halophilic and halotolerant bacterial species (Lentzen and Schwarz 2006; Ono et al. 1998; Roberts 2005). Ectoine is produced at a wide range of NaCl concentrations and reached maximum production at $\geq 10\%$ NaCl (Figs. 1a and 2a), while hydroxyectoine is present only when minimum NaCl concentration in the medium is 10% w/v (Figs. 1b and 2b). These features are in accordance with earlier observations made for other *Halomonas* spp. (Ono et al. 1998).

As both ectoine and PHB are intracellular compounds, their yields are linked to the amount of cell mass obtained; however, conditions for optimal production of these components are not the same. The high salt concentration needed for ectoine production affects the rate of PHB accumulation besides cell growth, which is optimal at 4.5% (w/v) NaCl (Quillaguamán et al. 2006). PHB accumulation is favored under nitrogen limitation, which is a sub-optimal condition for cell growth and metabolism (Quillaguamán et al. 2007, 2008). Hence, in order to obtain high cell mass

as well as high productivity of ectoine and PHB, the production was divided into two stages—one favoring the production of cell mass and the other was conducive for the synthesis of the two products.

Fed-batch mode of cultivation was adopted as it has provided a significant increase in cell mass than batch cultivation (Quillaguamán et al. 2008). Our earlier studies have also shown glutamine or glutamate together with NH_4Cl to constitute the best nitrogen source for the growth of *H. boliviensis* (Quillaguamán et al. 2008). Glutamate has been used as a carbon source for the production of ectoine by *B. epidermis* (Onraedt et al. 2005). Glutamate is in fact produced as a compatible solute by several halotolerant bacteria (Roberts 2005). The first fed-batch cultivation was performed in a medium with 4.5% NaCl, and the cells were harvested during exponential phase and transferred to a medium with higher NaCl concentration for the production of ectoine. Analysis of the 0-h samples showed accumulation of both ectoine and PHB to a significant extent (9–10% and 17–20% of cell dry weight, respectively; Fig. 3a). The increase in ectoine content during the second cultivation at 7.5% NaCl was marginal but was nearly doubled 18 h at 12.5% NaCl to 17 wt.%, which is comparable to the ectoine content obtained in *H. elongata* and *B. epidermis*, respectively. However, the maximum ectoine concentration reached at both salt concentrations was similar (about $5.5\text{--}5.7 \text{ g L}^{-1}$) due to differences in the cell growth. This concentration is lower than that reported for *H. elongata* and *B. epidermis* (Sauer and Galinski 1998; Onraedt et al. 2005). The increase in PHB content, on the other hand, was more significant at lower salt concentration. Formation of PHB in *H. boliviensis* has earlier been reported during the late exponential phase but is mainly triggered by depletion of the nitrogen source as the cell number increases (Quillaguamán et al. 2006, 2008).

In order to reduce an early accumulation of PHB in *H. boliviensis* cells, the concentration of the nitrogen source,

Table 2 Comparison of ectoine production by fed-batch cultivation of *Halomonas boliviensis* with other bacterial species regarded as holding potential for industrial application

Organisms	NaCl (g L^{-1})	Ectoine content (wt.%)	CDW (g L^{-1})	Ectoine concentration (g L^{-1})	Volumetric productivity ^a ($\text{g L}^{-1} \text{ day}^{-1}$)	Reference
<i>Halomonas boliviensis</i>	125	17	33.5	5.7	3.4	This work
<i>Halomonas boliviensis</i>	75	7.2	61.9	4.3	2.8	This work
<i>Halomonas elongata</i> ^b	150	15.5	40.0	6.2	1.3	Sauer and Galinski (1998)
<i>Halomonas elongata</i> ^c	150	15.5	48.0	7.4	5.3	Sauer and Galinski (1998)
<i>Brevibacterium epidermis</i>	58.5	16.0	49.0	8.0	2.0	Onraedt et al. (2005)
<i>Escherichia coli</i>	0	27.0	22.0	6.0	0.8	Schubert et al. (2007)

^a Calculated based on entire production time including growth and ectoine synthesis

^b Calculated after 1 cycle of the “bacterial milking” process

^c Calculated after 9 cycles of the “bacterial milking” process

glutamate and NH_4^+ , and phosphate were maintained during the first-stage cultivation and also during the initial hours of the second stage. The cells from the first cultivation had a PHB content of 8.9 wt.%, which is nearly half of that obtained in the earlier experiment. PHB accumulation was triggered in the second cultivation by limiting the addition of the N and P sources in the culture medium. As noted in the previous report, phosphate consumption by *H. boliviensis* cells was not significant, and its limitation did not influence PHB production (Quillaguamán et al. 2008). The salt concentration was increased only to 7.5% (w/v) to provide favorable conditions for both the polymer and the compatible solute (Fig. 4a, b). PHB accumulation rate and yield were significantly improved (Fig. 4a) and were in the same range as reported earlier by us when ectoine production was not considered (Quillaguamán et al. 2008) and as reported for *A. vinelandii* (Page and Cornish 1993) and *P. extrorquens* (Suzuki et al. 1986)—the microorganisms regarded to have potential for industrial exploitation (Lee 1996). The polymer yield was, however, lower than that of *A. latus* (Wang and Lee 1997) and recombinant *E. coli* (Choi et al. 1998).

The final ectoine volumetric productivity ($2.8 \text{ g L}^{-1} \text{ day}^{-1}$) was lower than that ($3.4 \text{ g L}^{-1} \text{ day}^{-1}$) obtained at higher salt concentration where the PHB formation was restricted (Table 2). Comparison with the earlier reports on ectoine production showed the productivity to be higher than that reported for *B. epidermis* and recombinant *E. coli* (Table 2). The productivity was also higher than that of the industrial production strain *H. elongata* if calculated based on one production cycle but was lower when nine production cycles are considered (Sauer and Galinski 1998). Recently, coupled production of polyhydroxyalkanoates and ectoine at levels of 50% and 14 wt.%, respectively, by *H. elongata* grown at 100 g L^{-1} NaCl in fed-batch culture has been reported (Mothes et al. 2008). Owing to the low cell density (6 g L^{-1}) attained and long cultivation time required, the ectoine productivity was significantly low (i.e., $0.28\text{--}0.42 \text{ g L}^{-1} \text{ day}^{-1}$).

The observation that ectoine production is accompanied by an increase in the residual cell mass of *H. boliviensis* and PHB is mainly accumulated when the RCM is constant (Fig. 4b) confirms that ectoine is synthesized during the exponential phase of cell growth, as commonly observed in other *Halomonas* spp. (Ono et al. 1998; Sauer and Galinski 1998), while PHB production starts during the late exponential phase and continues during the stationary phase. Acetyl-CoA is a common precursor for the synthesis of both PHB and ectoine (Cánovas et al. 1999; Reddy et al. 2003; Mothes et al. 2008); hence, metabolic flux to either of these products would have an influence on the production of the other. This may explain the reduction in

the PHB production rate and yield when ectoine synthesis is promoted with increasing salt concentration (Fig. 2b) and the reduction in ectoine production when PHB accumulation is favored (Figs. 3a and 4b).

The study presented in this paper shows the moderate halophile, *H. boliviensis*, to be yet another potential candidate for production of ectoine. The organism has an advantage in that comparably high levels of ectoine are produced at a relatively lower concentration of NaCl (7.5% (w/v)) as compared to that used for *H. elongata* (10–15% w/v NaCl). At this salt concentration, hydroxyectoine is not formed, which simplifies the downstream processing of ectoine. The study further shows the possibility of combining the production of ectoine with that of PHB—products gaining increasing importance for various applications. Co-production of ectoine with PHB by the organism in a process as described here may result in lowered production costs of the respective molecules. On the other hand, using the cells for ectoine production at higher salt concentration and by applying the concept of bacterial milking can significantly improve the productivity of the compatible solute including also hydroxyectoine.

Acknowledgments The authors would like to thank the Swedish International Development Cooperation Agency (Sida) and Swedish Research Council through the Swedish Research Link program for supporting this work. JM was supported by Erasmus fellowship from the European Commission.

References

- Cánovas D, Borges N, Vargas C, Ventosa A, Nieto JJ, Santos H (1999) Role of N- γ -acetyldiaminobutyrate as an enzyme stabilizer and an intermediate in the biosynthesis of hydroxyectoine. *Appl Environ Microbiol* 65:3774–3779
- Choi J, Lee SY, Han K (1998) Cloning of the *Alcaligenes latus* polyhydroxyalkanoate biosynthesis genes and use of these genes for enhanced production of poly(3-hydroxybutyrate) in *Escherichia coli*. *Appl Microbiol Biotechnol* 64:4897–4903
- Galinski EA (1993) Compatible solutes of halophilic eubacteria: molecular principles, water–solute interaction, stress protection. *Experientia* 49:487–496
- Kunte HJ, Galinski EA, Trüper HG (1993) A modified FMOC-method for the detection of amino acid type osmolytes and tetrahydropyrimidines (ectoines). *J Microbiol Methods* 17:129–136
- Lee SY (1996) Plastic bacteria? Progress and prospects for polyhydroxyalkanoate production in bacteria. *Trends Biotechnol* 14:431–438
- Lee SY, Wong HH, Choi J, Lee SH, Lee SC, Han CS (2000) Production of medium-chain-length polyhydroxyalkanoates by high-cell-density cultivation of *Pseudomonas putida* under phosphorus limitation. *Biotechnol Bioeng* 68:466–470
- Lentzen G, Schwarz T (2006) Extremolytes: natural compounds from extremophiles for versatile applications. *Appl Microbiol Biotechnol* 72:623–634
- Lippert K, Galinski EA (1992) Enzyme stabilization by ectoine-type compatible solutes: protection against heating, freezing and drying. *Appl Microbiol Biotechnol* 37:61–65

- Louis P, Trüper HG, Galinski EA (1994) Survival of *Escherichia coli* during drying and storage in the presence of compatible solutes. *Appl Microbiol Biotechnol* 41:684–688
- Motta A, Romano I, Gambacorta A (2004) Rapid and sensitive NMR method for osmolyte determination. *J Microbiol Methods* 58:289–294
- Mothes G, Schubert T, Harms H, Maskow T (2008) Biotechnological coproduction of compatible solutes and polyhydroxyalkanoates using the genus *Halomonas*. *Eng Life Sci* 8:658–662
- Ono H, Okuda M, Tongpim S, Imai K, Shinmyo A, Sakuda S, Kaneko Y, Murooka Y, Takano M (1998) Accumulation of compatible solute, ectoine and hydroxyectoine, in a moderate halophile, *Halomonas elongata* KS3 isolated from dry salty land in Thailand. *J Ferment Bioeng* 85:362–368
- Onraedt AE, Wlaciarius BA, Soetaert WK, Vandamme EJ (2005) Optimization of ectoine synthesis through fed-batch fermentation of *Brevibacterium epidermis*. *Biotechnol Prog* 21:1206–1212
- Oren A (2002) Diversity of halophilic microorganisms: environments, phylogeny, physiology, and applications. *J Ind Microbiol Biotechnol* 28:56–63
- Page WJ, Cornish A (1993) Growth of *Azotobacter vinelandii* UWD in fish peptone medium and simplified extraction of poly- β -hydroxybutyrate. *Appl Environ Microbiol* 59:4236–4244
- Philip S, Keshavarz T, Roy I (2007) Polyhydroxyalkanoates: biodegradable polymers with a range of applications. *J Chem Technol Biotechnol* 82:233–247
- Quillaguamán J, Hatti-Kaul R, Mattiasson B, Alvarez MT, Delgado O (2004) *Halomonas boliviensis* sp. nov., an alkalitolerant, moderate halophile bacterium isolated from soil around a Bolivian hypersaline lake. *Int J Syst Evol Microbiol* 54:721–725
- Quillaguamán J, Hashim S, Bento F, Mattiasson B, Hatti-Kaul R (2005) Poly(β -hydroxybutyrate) production by a moderate halophile, *Halomonas boliviensis* LC1 using starch hydrolysate as substrate. *J Appl Microbiol* 99:151–157
- Quillaguamán J, Delgado O, Mattiasson B, Hatti-Kaul R (2006) Poly(β -hydroxybutyrate) production by a moderate halophile, *Halomonas boliviensis* LC1. *Enzyme Microb Technol* 38:148–154
- Quillaguamán J, Muñoz M, Mattiasson B, Hatti-Kaul R (2007) Optimising conditions for poly(β -hydroxybutyrate) production by *Halomonas boliviensis* LC1 in batch culture with sucrose as carbon source. *Appl Microbiol Biotechnol* 74:981–986
- Quillaguamán J, Doan-Van T, Guzmán H, Guzmán D, Martín J, Everest A, Hatti-Kaul R (2008) Poly(3-hydroxybutyrate) production by *Halomonas boliviensis* in fed-batch culture. *Appl Microbiol Biotechnol* 78:227–232
- Reddy CSK, Ghai R, Kalia V (2003) Polyhydroxyalkanoates: an overview. *Bioresour Technol* 87:137–146
- Roberts MF (2005) Organic compatible solutes of halotolerant and halophilic microorganism. *Saline Systems* 1:5. doi:10.1186/1746-1448-1-5
- Sauer T, Galinski EA (1998) Bacterial milking: a novel bioprocess for production of compatible solutes. *Biotechnol Bioeng* 57:306–313
- Schiraldi C, Maresca C, Catapano A, Galinski EA, De Rosa M (2006) High-yield cultivation of *Marinococcus* M52 for production and recovery of hydroxyectoine. *Res Microbiol* 157:693–699
- Schubert T, Maskow T, Benndorf D, Harms H, Breuer U (2007) Continuous synthesis and excretion of the compatible solute ectoine by a transgenic, nonhalophilic bacterium. *Appl Environ Microbiol* 73:3343–3347
- Suzuki T, Yamane T, Shimizu S (1986) Mass production of poly- β -hydroxybutyric acid by fed-batch culture with controlled carbon/nitrogen feeding. *Appl Microbiol Biotechnol* 24:370–374
- Vargas C, Jebbar M, Carrasco R, Blanco C, Calderón MI, Iglesias-Guerra F, Nieto JJ (2006) Ectoines as compatible solutes and carbon and energy sources for the halophilic bacterium *Chromohalobacter salexigens*. *J Appl Microbiol* 100:98–107
- Wang F, Lee SY (1997) Poly(3-hydroxybutyrate) production with high productivity and high polymer content by a fed-batch culture of *Alcaligenes latus* under nitrogen limitation. *Appl Environ Microbiol* 63:3703–3706
- Welsh DT (2000) Ecological significance of compatible solute accumulation by micro-organisms: from single cells to global climate. *FEMS Microbiol Rev* 24:263–290
- Xu X, Matsuo C, Abo M, Okubo A, Yamazaki S (2001) Identification of osmotic regulators in halophilic photosynthetic bacteria by NMR and capillary electrophoresis. *Anal Sci* 17:601–604

Ectoine production by *Halomonas boliviensis*: optimization using response surface methodology

Doan Van-Thuoc · Héctor Guzmán · Mai Thi-Hang · Rajni Hatti-Kaul

D. Van-Thuoc · H. Guzmán · R. Hatti-Kaul

Department of Biotechnology, Center for Chemistry and Chemical Engineering, Lund University, P.O. Box 124, SE-221 00 Lund, Sweden

D. Van-Thuoc · M. Thi-Hang

Department of Micro-biotechnology, Faculty of Biology, Hanoi National University of Education, 136 Xuan Thuy, Cau Giay, Hanoi, Viet Nam

H. Guzmán

Centro de Biotecnología, Facultad de Ciencias y Tecnología, Universidad Mayor de San Simón, Cochabamba, Bolivia.

Corresponding author: E-mail: Thuoc.Doan_Van@biotek.lu.se

Phone: +46 46 222 4948

Fax: + 46 46 222 4713

Abstract Two cultivation steps were used for production of biomass and ectoine by *Halomonas boliviensis*, respectively. The optimization of some nutrient parameters in each step was investigated by using response surface methodology. 20 and 12 experiments were performed to attain optimal conditions for biomass and ectoine production, respectively. The model predicted a maximum biomass concentration of 3.34 g/L on optimization of NH_4Cl , K_2HPO_4 , and $\text{MgSO}_4 \cdot 7\text{H}_2\text{O}$ concentrations during the first cultivation, while a maximum ectoine concentration of 1.27 g/L was predicted on optimizing NaCl and monosodium glutamate concentrations in the second cultivation. The experimental values obtained (3.36 g biomass/L and 1.25 g ectoine/L) were in good agreement with the predicted values. The optimized conditions were also used for two-step 1.5 L fed-batch fermentations. In the first step, biomass concentration of 28.7 g/L was obtained while in the second step biomass concentration increased to 63 g/L. Ectoine concentration of 9.2 g/L was obtained and the overall ectoine productivity was 6.3 g/L/d, is among the highest reported so far.

Keywords *Halomonas boliviensis* · Two cultivation steps · Biomass · Ectoine · Response surface methodology

Introduction

Microorganisms that are capable of growing at high salt concentrations achieve osmotic balance across the cell membrane in two ways: one that is typical for the archaeal *Halobacteriaceae*, involves accumulation of inorganic solutes (potassium and chloride ions) (Galinski 1993; Galinski and Trüper 1994; Roberts 2005; Oren 2002), and the other, widely used by bacterial halophilic/halotolerant organisms, is the accumulation of low molecular mass organic compounds called compatible solutes (Galinski 1993; Roberts 2005; Lentzen and Schwarz 2006; Oren 2008). Ectoine is the most abundant compatible solute produced intracellularly in high concentrations by halophilic/halotolerant bacteria (Roberts 2005; Oren 2008). Apart from the purely osmotic function, ectoine has recently gained increasing interest in biotechnology, for protection of enzymes, DNA, and whole cells against stresses such as freezing, drying, and heating (Lippert and Galinski, 1992; Louis *et al.*, 1994; Welsh, 2000). Moreover, ectoine can be used as moisturizer in cosmetics or skin care products, as chiral building block and possibly also as protecting agent for healthy cells during chemotherapy (Lentzen and Schwarz, 2006).

Production of ectoine has been reported earlier in a process called “bacterial milking” using the moderate halophilic strain *Halomonas elongata* (Sauer and Galinski 1998). The organism produces compatible solutes in response to the salinity of the medium and rapidly releases them when subjected to an osmotic downshock. It has been shown that on re-incubation in a medium of high salt concentration the cells are able to synthesise again the compatible solute, and the procedure could be repeated for a number of cycles. By repeatedly performing the “bacterial milking”

process, maximum yield of ectoine achieved was about 155 mg per cycle per gram cell dry weight (CDW), and the volume productivity was approximately 5.3 g/L/d (calculated for nine cycles).

We have recently investigated production of ectoine by *Halomonas boliviensis* (Guzmán *et al.* 2009). The organism is a moderate halophile isolated by us and that is able to grow at NaCl concentration of 0-25 % (w/v) (Quillaguamán *et al.* 2004). Our earlier studies have also shown the potential of *H. boliviensis* for production of polyhydroxybutyrate (PHB), a biodegradable polymer (Van-Thuoc *et al.* 2008; Quillaguamán *et al.* 2006, 2007, 2008). Maximum PHB content of 81% of CDW (44 g/L) and –volumetric productivity of 1.1 g/L/h have been achieved using fed-batch mode of cultivation (Quillaguamán *et al.* 2008). Production of PHB occurs optimally at the medium salt concentration of 4.5 % (w/v), while the accumulation of ectoine increases on increasing the salt concentration up to 10-15 % (w/v). At a higher range of salt concentration (10-15 %, w/v), even hydroxyectoine was detected in small amounts (Guzmán *et al.* 2009). We have further developed a process for the co-production of ectoine and PHB, providing ectoine content and volumetric productivity of 7% of CDW (62 g/L) and 2.8 g/L/d, respectively, and PHB content and volumetric productivity of 68.5% of CDW and 1.06 g/L/h, respectively (Guzmán *et al.* 2009).

Being an intracellular product, ectoine yield is related to that of the biomass. However the conditions of optimal production of ectoine and the cell mass are different with respect to the salinity of the culture medium. Although ectoine production may be induced by addition of salt to the medium after the cells have been grown, it has been noted earlier that concentrations of both biomass and ectoine are

improved by medium exchange that helps to reduce the inhibitory effect of the metabolic by-products formed during high cell-density fermentation (Frings et al. 1995; Sauer and Galinski 1998). A two-step process is hence used, the first for achieving high cell mass and the second for inducing high ectoine accumulation. Optimization of the cultivation conditions is required to obtain high productivity in the respective steps.

Recently many statistical experimental design methods have been successfully employed in the bioprocess optimization. Among them, response surface methodology (RSM) has been widely applied to many biotechnological areas (Bali 2004; Barrington and Kim 2008; Huang et al. 2007; Soni et al. 2007). It involves a set of designed experiments to determine the optimum operating conditions for the process or to determine a region of the factor space in which operating specifications are satisfied (Montgomery 2001).

In the present study, optimization of culture medium components has been performed for the two-step cultivation of *Halomonas boliviensis* for production of biomass and

ectoine, respectively, by application of the RSM using the Box-Wilson design method (Box and Wilson 1951).

Materials and methods

Bacterial strain and maintenance

Halomonas boliviensis LC1^T (=DSM 15516^T) was maintained at 4 °C on solid HM medium (Quillaguamán et al. 2004), containing (% w/v): NaCl, 4.5; MgSO₄·7H₂O, 0.025; CaCl₂·2H₂O, 0.009; KCl, 0.05; NaBr, 0.006; peptone, 0.5; yeast extract, 1.0; glucose, 0.1; and granulated agar, 2.0. The pH of the medium was adjusted to 7.5 using 1 M NaOH.

Media and culture conditions

The culture medium used in this study was based on a medium designed for *H. elongata* (Table 1) (Sauer and Galinski 1998). Glucose and monosodium glutamate were sterilized separately. The pH was adjusted to 7.5 using 5M HCl solution.

Biomass production in shake flask

H. boliviensis was grown in 100 mL of seed culture medium (Table 1) in 500 mL

Table 1 Media composition for biomass and ectoines production by *H. boliviensis* in shake flasks and fermentor, respectively

Component	Seed culture	Biomass production	Ectoine production	Fermentor medium	Feed solution
	g/L	g/L	g/L	g/L	g/L
Glucose	10	20	20	20	500
NaCl	45	45	V	V	V
NH ₄ Cl	2.3	V	2.0	4.0	40
MgSO ₄ ·7H ₂ O	2.5	V	3.47	6.94	69.4
K ₂ HPO ₄	0.55	V	1.77	3.54	35.4
FeSO ₄ ·7H ₂ O	0.005	0.005	0.005	0.01	0.02
Tris	15	2	2	-	-
Glutamine	2	-	-	-	-
Monosodium glutamate	-	10	V	20	-

V: Component concentration was varied in different experiments

Erlenmeyer flasks on a rotary shaker (New Brunswick Scientific Co., NJ, USA) at 30 °C and 200 rpm for 13 h ($OD_{620} = 2.5 \pm 0.1$). Subsequently, 1 mL of the culture was inoculated in 500 mL Erlenmeyer flask containing 100 mL of medium for biomass production (Table 1). The culture was incubated at 30 °C with shaking at 200 rpm, and samples were withdrawn at 15 h of cultivation for biomass analysis.

Ectoine production in shake flask

H. boliviensis was grown as described above. After 15 h of growth to generate the cell mass, the bacterial cells were harvested from the culture broth by centrifugation at 5500 g for 10 min. The cells were then suspended in 100 mL medium with varying concentrations of NaCl and monosodium glutamate (MSG), respectively, in 500 mL Erlenmeyer flasks for ectoine production (Table 1). The culture was incubated for 30 h under similar conditions as above and samples were taken for biomass and ectoine analysis.

Two cultivation steps in fermentor

H. boliviensis was first grown in 150 mL of seed culture medium in 1 L flask, with shaking at 200 rpm and 30 °C for 13 h ($OD_{620} = 2.5 \pm$

0.1). The medium was then used to inoculate 1.35 L of medium with 45 g/L NaCl (Table 1) in a 2-L fermentor (Voyager, Luton, UK). After 16 hours, cells were harvested from the culture broth by centrifugation at 5500 g for 10 min, and used to inoculate 1.4 L of medium with 155 g/L NaCl (Table 1). The samples were taken every 3 h for biomass and ectoine analysis.

Fed-batch fermentation was performed at 30 °C, pH 7.5. The agitation speed was initially set at 700 rpm and increased to 800, 900, 1000, and 1100 rpm after 6, 9, 12, and 15 h of cultivation, respectively. The initial air inflow rate of 1 L/min was increased up to 5 L/min during the fermentation to maintain the dissolved oxygen concentration above 40%. A feed solution (Table 1) and 50 % (w/v) MSG solution were pumped into the fermentor to maintain the concentration of glucose at 20 g/L and glutamate at 10 g/L with the help of off-line analysis.

Analytical methods

Biomass concentration was determined by centrifuging 3 mL of the culture samples at 2 000 g for 15 min in a pre-weighed centrifuge tube, the pellet washed quickly once with 3 mL distilled water, centrifuged and dried at 70 °C

Table 2 The parameter values and their levels used for central composite design for biomass and ectoine production

Variable	Parameter	Level				
Equation 3		-1.682	-1	0	1	1.682
x_1	NH ₄ Cl (g/L)	1.36	1.7	2.2	2.7	3.04
x_2	MgSO ₄ ·7H ₂ O (g/L)	1.65	2.2	3.0	3.8	4.35
x_3	K ₂ HPO ₄ (g/L)	0.53	0.8	1.2	1.6	1.87
Equation 4		-1.414	-1	0	1	1.414
x_1	MSG (g/L)	2.93	5	10	15	17.07
x_2	NaCl (g/L)	63.4	80	120	160	176.6

until constant weight was obtained. The centrifuge tube was weighed again to calculate the biomass concentration.

Glucose concentration was analyzed by Accu-Chek sensors (Roche, Mannheim, Germany).

Extraction of ectoine for its analysis was performed as reported previously (Kunte et al. 1993). Ectoine and MSG concentration were determined by HPLC analysis (Onraedt et al. 2005), using a Perkin-Elmer HPLC system with an Aminex HPX-87C column (Biorad) and a UV detector at 65 °C. Calcium chloride (5 mM) was used as mobile phase at a flow rate of 0.3 mL/min. The compounds were monitored at 210 nm.

The intracellular ectoine content per g biomass and the total ectoine concentration per litre culture broth were determined.

All experiments and analyses were performed in duplicates.

Table 3 Experiment design with experimental and predicted values of biomass concentration

Run	x ₁	x ₂	x ₃	Biomass conc. (g/L)	
	NH ₄ Cl	MgSO ₄ ·7H ₂ O	K ₂ HPO ₄	Experimental	Predicted
1	1	1	1	3.23	3.22
2	1	1	-1	2.83	2.87
3	1	-1	1	3.10	3.05
4	1	-1	-1	2.73	2.74
5	-1	1	1	3.33	3.31
6	-1	1	-1	3.00	3.04
7	-1	-1	1	3.10	3.05
8	-1	-1	-1	2.83	2.83
9	1.682	0	0	3.03	3.03
10	-1.682	0	0	3.17	3.18
11	0	1.682	0	3.10	3.07
12	0	-1.682	0	2.70	2.75
13	0	0	1.682	3.23	3.30
14	0	0	-1.682	2.87	2.81
15	0	0	0	3.20	3.20
16	0	0	0	3.26	3.20
17	0	0	0	3.23	3.20
18	0	0	0	3.14	3.20
19	0	0	0	3.17	3.20
20	0	0	0	3.20	3.20

Table 4 Experiment design with experimental and predicted values of ectoine production

Run	x ₁	x ₂	Ectoine conc. (g/L)	
	MSG	NaCl	Experimental	Predicted
1	1	1	1.11	1.14
2	1	-1	0.95	0.99
3	-1	1	1.08	1.06
4	-1	-1	0.73	0.72
5	1.414	0	1.03	0.99
6	-1.414	0	0.73	0.75
7	0	1.414	1.26	1.26
8	0	-1.414	0.93	0.91
9	0	0	1.23	1.21
10	0	0	1.18	1.21
11	0	0	1.21	1.21
12	0	0	1.22	1.21

Experimental design and statistical analysis

After approximate estimation of the best medium composition by using the “one variable at a time” method, the central composite experimental design (CCED) (Box and Wilson 1951) was applied to optimize media constituents for biomass and ectoine production. The variables X_i were coded as x_i according to the equation 1 (Eq.1)

$$x_i = (X_i - X_0)/\Delta X_i, \quad i=1,2,3,\dots,k. \quad (1)$$

where x_i is the coded value of the ith test variable, X_i is the real value of ith test variable, X₀ is the real value of ith test variable at center point, and ΔX_i is the step change value.

The design matrix and levels of independent variables chosen for biomass and ectoine production are shown in Tables 2, 3, and 4, respectively.

Regression analysis and analysis of variance (ANOVA) were performed on the data obtained using MINITAB 14 software. A second order polynomial used to fit the response to independent variable is shown in Eq. 2:

$$Y = \beta_o + \sum_{i=1}^k \beta_i x_i + \sum_{i=1}^k \beta_{ii} x_i^2 + \sum_{i < j}^k \beta_{ij} x_i x_j \quad (2)$$

where Y is the response variable, x_i and x_j ($i=1,k; j=1,k; i \neq j$) are the input variables that influence the response variable Y , β_o is the intercept, β_i represents the linear effect of x_i , β_{ij} represents the interaction between x_i and x_j , while β_{ii} represents the quadratic effect of x_i . Optimum combinations of independent variables were determined by optimizing the second order polynomial equation (Eq.2) using MATLAB 7.0.4 software. Response surface and contour plot showing the effect of the variables on biomass and ectoine concentrations were also obtained with the aid of the same software.

Results and discussion

Optimization of media constituents for biomass production

Based on preliminary experiments conducted earlier (Quillaguamán et al. 2007, 2008), and the approximate estimation of the best medium composition by using the “one variable at a time” method, initial NH_4Cl , MgSO_4 , and K_2HPO_4 were chosen as important process parameters in order to optimize biomass production. Using the CCED method for three-factor and five-coded levels, the range of the variables was determined (Table 2). A total of 20 experiments with different combinations of nutrient concentrations were performed and the results obtained for biomass production are

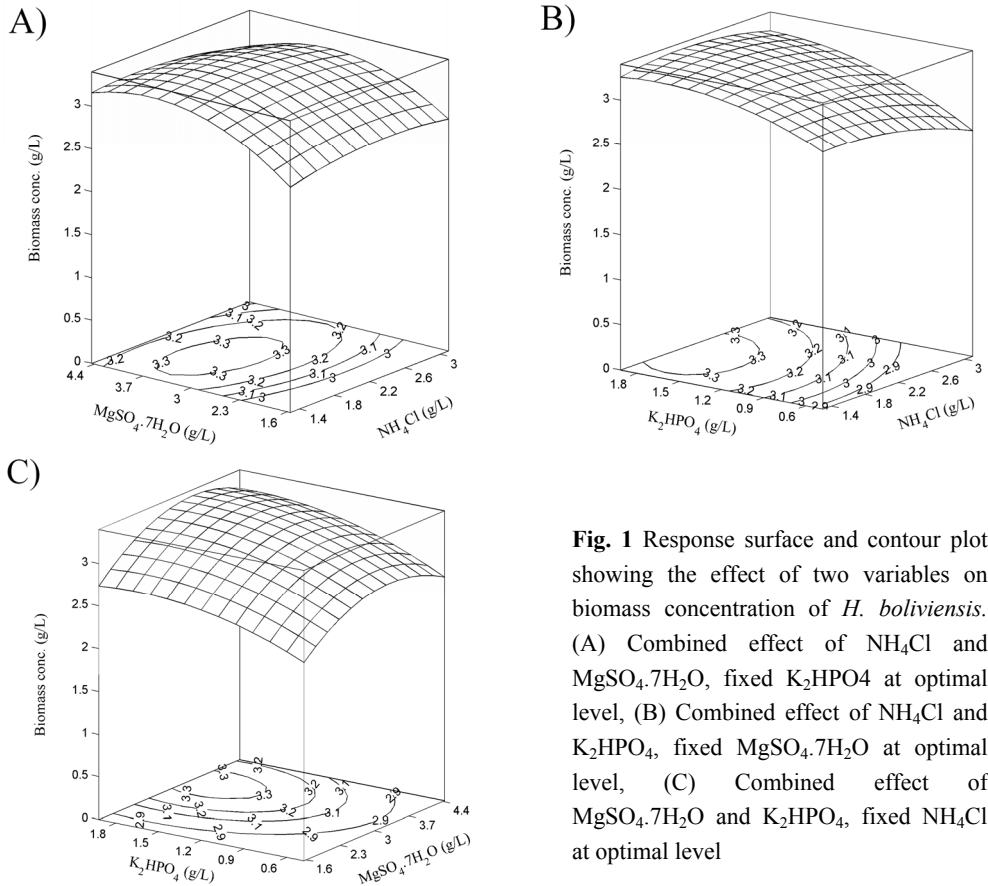

Fig. 1 Response surface and contour plot showing the effect of two variables on biomass concentration of *H. boliviensis*. (A) Combined effect of NH_4Cl and $\text{MgSO}_4 \cdot 7\text{H}_2\text{O}$, fixed K_2HPO_4 at optimal level, (B) Combined effect of NH_4Cl and K_2HPO_4 , fixed $\text{MgSO}_4 \cdot 7\text{H}_2\text{O}$ at optimal level, (C) Combined effect of $\text{MgSO}_4 \cdot 7\text{H}_2\text{O}$ and K_2HPO_4 , fixed NH_4Cl at optimal level

presented in Table 3. The analysis of experimental results was carried out using MINITAB 14 software. The calculated coefficients are shown in Supplementary Table 1. The coefficient of determination (R^2) for biomass production was 0.956, which showed a good agreement between experimental observation and predicted value, and 95.6 % of the variability in the response could be explained by the model. A following second-order equation model was found to explain the biomass production by *H. boliviensis*.

$$Y_{\text{biomass conc.}} = 3.1996 - 0.0443x_1 + 0.0954x_2 + 0.1446x_3 - 0.0326x_1^2 - 0.1033x_2^2 - 0.0502x_3^2 - 0.0213x_1x_2 + 0.0213x_1x_3 + 0.0113x_2x_3 \quad (3)$$

The Student's *t*-test was used to determine the significance of the regression coefficients of the variables. The test parameter is significant at 5% level if *P* value is below 0.05. The data showed that in both linear and quadratic terms NH_4Cl was significant at 5% level (given by *P* value below 0.05), and had a negative effect, while $\text{MgSO}_4 \cdot 7\text{H}_2\text{O}$ and K_2HPO_4 had positive linear and negative quadratic effects on biomass production (all terms are significant at 1% level, given by *P* value below 0.01). Among the three nutrients, K_2HPO_4 had highest linear coefficient (0.1446), followed by $\text{MgSO}_4 \cdot 7\text{H}_2\text{O}$ (0.0954) and NH_4Cl (-0.0443), suggesting that the phosphate salt has higher influence than the other two on biomass production. K_2HPO_4 is important for providing elements for biomass, and also K^+ ions for intracellular accumulation of salt in the organism to maintain turgor pressure and cell volume.

The statistical significance of the model was carried out using Fisher's test for ANOVA (Supplementary Table 2). The model *F* value of 24.24 and *P* value below 0.0001 were

determined, which supported that the model is very fit and can adequately explain the variation observed (significant at 1% level). The *P* value for lack of fit was 0.204 (insignificant at 5% level), indicating that the experimental data obtained fitted well with the model.

Fig. 1 shows the response surface and contour plot of biomass production, fixing one variable at optimal level, while varying the other two within their experimental range. From the figure, it is clear that biomass concentration increases with the decrease in NH_4Cl concentration from 3 to 1.8 g/L (Figs 1A, and 1B), whereas high biomass concentration was reached at increased levels of K_2HPO_4 from 0.6 to 1.8 g/L and $\text{MgSO}_4 \cdot 7\text{H}_2\text{O}$ from 1.6 to 3.7 g/L (Figs 1A, 1B, and 1C). The best concentrations of NH_4Cl , K_2HPO_4 , and $\text{MgSO}_4 \cdot 7\text{H}_2\text{O}$ for biomass production were around 1.8-2.2 g/L, 1.5-1.8 g/L, and 3.3-3.7 g/L, respectively. The model predicted the maximum biomass concentration of 3.34 g/L, corresponding to the coded values of the independent variables: $x_1 = -0.407$, $x_2 = 0.5811$, and $x_3 = 1.4181$. In decoding the factors, the optimum levels in real value were determined, which were 2 g/L NH_4Cl , 3.47 g/L $\text{MgSO}_4 \cdot 7\text{H}_2\text{O}$, and 1.77 g/L K_2HPO_4 . The second-order model was confirmed experimentally using a medium representing the maximum point. An average biomass concentration of 3.36 g/L was obtained, which was in good agreement with the predicted value (3.34 g/L), demonstrating the accuracy of experimental data and the applicability of RSM.

Optimization of media constituents for ectoine production

Previous studies have shown that sodium chloride and monosodium glutamate are the key factors having extreme influence on cell growth and intracellular ectoine synthesis by halotolerant and halophilic microorganisms (Onraedt et al. 2005; Roberts 2005; Saum and Müller 2008). Based on the data of the approximate estimation of the best medium composition by using the “one variable at a time” method, a central composite experimental design leading to a set of 12 experiments containing 4 center points with different combinations of NaCl and MSG was carried out to attain the optimal conditions for ectoine production by *H. boliviensis*. The range of the variables is listed in Table 2, while experimental design and results obtained for ectoine concentration are summarized in Table 4. Based on these data the regression coefficients, *t* and *P* values for all linear, quadratic and interaction effect of the variables are calculated using MINITAB 14 software and presented in Supplementary Table 3. The results show that NaCl and MSG had positive linear and negative quadratic effects on ectoine concentration (significant at 1% level). The interaction between NaCl and MSG was significant at 5% level, and had negative effect on ectoine concentration. The coefficient of determination (R^2) for ectoine concentration was 0.984 (Supplementary Table 3), which indicated that 98.4 % of the variability in the response could be explained by the model. Moreover, the adjusted coefficient of determination ($R^2_{adj} = 0.97$) was also very high implying high degree of correlation between the observed and predicted values. As a result the fitted second-order model equation for ectoine production was:

$$Y_{\text{ectoine conc.}} = 1.21 + 0.0843x_1 + 0.1221x_2 - 0.17x_1^2 - 0.0625x_2^2 - 0.0475x_1x_2 \quad (4)$$

On the basis of the experimental and predicted values, statistical testing was carried out using Fisher’s test in form of ANOVA (Supplementary Table 4). The results showed that the model was statistically significant at 99%, as is evident from the calculated *F* value (72.37) and a very low *P* value (<0.0001). The *P* value for lack of fit (0.168) was statistically insignificant at 5% level. Hence, statistical analysis demonstrated that the experimental data obtained fitted well with the model and the model can explain the effect of NaCl and MSG on ectoine production by *H. boliviensis* within tested ranges.

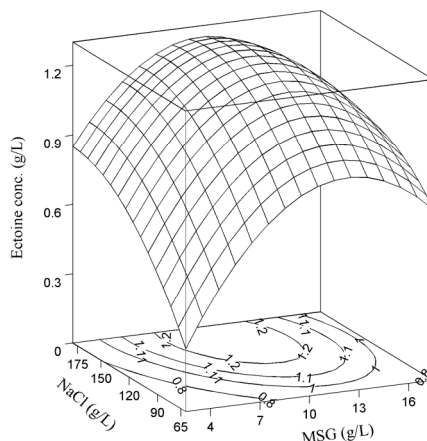

Fig. 2 Response surface and contour plot showing the effect of NaCl and MSG on ectoine concentration

A three-dimensional graph for response surface/contour plot model shows the combined effect of NaCl and MSG on ectoine concentration (Fig. 2). It is evident that increase in NaCl and MSG concentrations results initially in enhancement of ectoine production followed by a decrease in production. As increase in NaCl concentration has different effects on the intracellular ectoine accumulation and growth rate of bacterial cells,

an optimum salt concentration, leading to the highest total ectoine concentration, is observed around 150 to 160 g/L (Fig. 2). Increasing MSG concentration was found to be good for the biomass production as well as ectoine synthesis by *H. boliviensis*. The optimum concentration of MSG for ectoine synthesis was around 10-11 g/L (Fig. 2). To find the predicted response at the stationary point the canonical analysis was performed, which gave optimum values of NaCl and MSG as 157.3 g/L and 10.6 g/L, respectively. The predicted optimal ectoine concentration corresponding to these values is 1.27 g/L. Experiments done to validate the optimized values of NaCl and MSG gave an average of 1.25 g/L ectoine concentration, suggesting that the model was also valid for ectoine production.

Two-step fed-batch fermentation

The optimized conditions were then tested under fed-batch conditions for production of biomass and ectoine. Nutrients were maintained at a constant level during the fermentation by using off-line analysis, and adding feed solution and 50 % MSG solution as reported earlier (Guzmán et al. 2009).

During the first cultivation, a cell mass concentration of 28.7 g/L was reached after 16 h of cultivation. The cells were then transferred to the second fed-batch cultivation for ectoine production. Figure 3 shows that biomass concentration increased to 63 g/L and the ectoine concentration of 9.2 g/L was obtained after 18 h of cultivation in the second step. The significant increase in biomass concentration was most likely due to the removal of inhibitory by-products formed during the first cultivation and is in accordance with the report on increase in cell density obtained for *Marinococcus* M52 during cultivation with

medium exchange (Frings et al. 1995). Taking into account the total production time of 16 h for the first fed-batch, 1 h for harvesting and resuspending the cells and the time for the second fed-batch, the overall ectoine volumetric productivity was about 6.3 g/L/d, i.e. 2.3 times higher compared to the previous study (Guzmán et al. 2009).

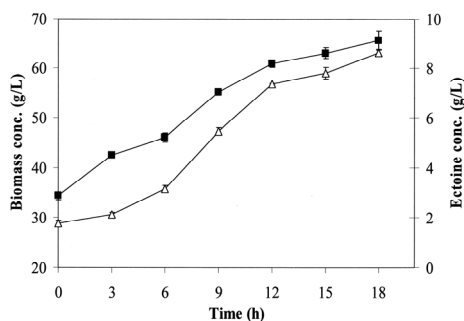

Fig. 3 Ectoine production during the second-step fed-batch cultivation under optimized conditions by *H. boliviensis*. The symbols represent Biomass concentration (Δ), ectoine concentration (\blacksquare)

The results obtained here are comparable to that of the highest reported so far for *H. elongata* (Sauer and Galinski 1998), and *Brevibacterium epidermis* (Onraedt et al. 2005). Ectoine content (g ectoine/g biomass) is in the same range: *H. boliviensis* (0.145) (data not shown), *H. elongata* (0.155), and *B. epidermis* (0.16). On the other hand, the highest biomass concentration (63 g/L) in case of *H. boliviensis* was achieved in a significantly shorter time of growth (35 h) as compared to that for *H. elongata* (40 g/L after 110 h growth) and *B. epidermis* (50 g/L after 96 h of growth). If calculated for one cycle, the overall ectoine volumetric productivity obtained by *H. boliviensis* (6.3 g/L/d) is much higher than that

obtained by *H. elongata* (1.3 g/L/d) and *B. epidermis* (2 g/L/d).

Conclusion

The application of RSM allowed a quick optimization of medium components for ectoine production by *Halomonas boliviensis*. The good fitting between experimental and predicted values reflected the accuracy and the applicability of RSM. The optimized medium also showed improvement in ectoine productivity when used in fed-batch fermentation. The study establishes *H. boliviensis* and the cultivation conditions to be an attractive choice for ectoine production. The overall ectoine volumetric productivity of 6.3 g/L/d, was higher than that reported in our previous study and also compared to other organisms based on one production cycle. It would be interesting to evaluate the production by the organism using the bacterial milking concept. Further work will also involve the production of hydroxyectoine by *H. boliviensis*.

Acknowledgement The authors would like to thank the Swedish International Development Cooperation Agency (Sida) for supporting this work.

References

- Bali U (2004) Application of Box-Wilson experimental design method for the photodegradation of textile dyestuff with UV/H₂O₂ process. *Dyes and Pigments* 60:187-195
- Barrington S, Kim JW (2008) Response surface optimization of medium components for citric acid production by *Aspergillus niger* NRRL 567 grown in peat moss. *Bioresource Technol* 99:368-377
- Box GEP, Wilson KB (1951) On the experimental attainment of optimum condition. *J Royal Stat Soc B13*:1-45
- Frings E, Sauer T, Galinski EA (1995) Production of hydroxyectoine: high cell-density cultivation and osmotic downshock of *Marinococcus* strain M52. *J Biotechnol* 43:53-61.
- Galinski EA (1993) Compatible solutes of halophilic eubacteria: molecular principles, water-solute interaction, stress protection. *Experientia* 49:487-96
- Galinski EA, Trüper HG (1994) Microbial behaviour in salt-stressed ecosystems. *FEMS Microbiol Rev* 15:95-108
- Guzmán H, Van-Thuoc D, Martín J, Hatti-Kaul R, Quillaguamán J (2009) A process for the production of ectoine and poly(3-hydroxybutyrate) by *Halomonas boliviensis*. *Appl Microbiol Biotechnol* DOI 10.1007/s00253-009-2036-2.
- Huang X, Lu Z, Bie X, Lü FX, Zhao H, Yang S (2007) Optimization of inactivation of endospores of *Bacillus cereus* by antimicrobial lipopeptides from *Bacillus subtilis* fmbj strains using a response surface method. *Appl Microbiol Biotechnol* 74:454-461
- Kunte HJ, Galinski EA, Trüper HG (1993) A modified FMOC-method for the detection of aminoacid type osmolytes and tetrahydropyrimidines (ectoines). *J Microbiol Meth* 17:129-136
- Lentzen G, Schwarz T (2006) Extremolytes: natural compounds from extremophiles for versatile applications. *Appl Microbiol Biotechnol* 72:623-634
- Lippert K, Galinski EA (1992) Enzyme stabilization by ectoine-type compatible solutes: protection against heating, freezing and drying. *Appl Microbiol Biotechnol* 37:61-65

- Louis P, Trüper HG, Galinski EA (1994) Survival of *Escherichia coli* during drying and storage in the presence of compatible solutes. *Appl Microbiol Biotechnol* 41:684-688
- Montgomery DC (2001) Design and Analysis of Experiments 5th edn. John Wiley and Sons:New York
- Onraedt AE, Wlcarius BA, Soetaert WK, Vandamme E.J (2005) Optimization of ectoine synthesis through fed-batch fermentation of *Brevibacterium epidermis*. *Biotechnol Prog* 21:1206-1212
- Oren A (2002) Diversity of halophilic microorganisms: Environments, phylogeny, physiology, and applications. *J Ind Microbiol Biotechnol* 28:56-63
- Oren A (2008) Microbial life at high salt concentrations: phylogenetic and metabolic diversity. *Saline Systems (On-line Journal)* 4:2 DOI: 10.1186/1746-1448-4-2
- Quillaguamán J, Hatti-Kaul R, Mattiasson B, Alvarez MT, Delgado O (2004) *Halomonas boliviensis* sp. nov., an alkalitolerant, moderate halophile bacterium isolated from soil around a Bolivian hypersaline lake. *Int J Syst Evol Microbiol* 54:721-725
- Quillaguamán J, Delgado O, Mattiasson B, Hatti-Kaul R (2006) Poly(β -hydroxybutyrate) production by a moderate halophile, *Halomonas boliviensis* LC1. *Enz Microb Technol* 38:148-154
- Quillaguamán J, Muñoz M, Mattiasson B, Hatti-Kaul R (2007) Optimising conditions for poly(β -hydroxybutyrate) production by *Halomonas boliviensis* LC1 in batch culture with sucrose as carbon source. *Appl Microbiol Biotechnol* 74:981-986
- Quillaguamán J, Doan-Van T, Guzmán H, Guzmán D, Martín J, Everest A, Hatti-Kaul R (2008) Poly(3-hydroxybutyrate) production by *Halomonas boliviensis* in fed-batch culture. *Appl Microbiol Biotechnol* 78:227-232
- Roberts MF (2005) Organic compatible solutes of halotolerant and halophilic microorganism. *Saline Systems (On-line Journal)* 1:5 DOI: 10.1186/1746-1448-1-5
- Sauer T, Galinski EA (1998) Bacterial milking: A novel bioprocess for production of compatible solutes. *Biotechnol Bioeng* 57:306-313
- Saum SH, Müller V (2008) Regulation of osmoadaptation in the moderate halophile *Halobacillus halophilus*: chloride, glutamate and switching osmolyte strategies. *Saline Systems (On-line Journal)* 4:4 DOI: 10.1186/1746-1448-4-4
- Soni P, Singh M, Kamble AL, Banerjee UC (2007) Response surface optimization of the critical medium components for carbonyl reductase production by *Candida viswanathii* MTCC 5158. *Bioresource Technol* 98:829-833
- Van-Thuoc D, Quillaguamán J, Mamo G, Mattiasson B (2008) Utilization of agricultural residues for poly(3-hydroxybutyrate) production by *Halomonas boliviensis* LC1. *J Appl Microbiol* 104:420-428
- Welsh DT (2002) Ecological significance of compatible solute accumulation by microorganisms: from single cells to global climate. *FEMS Microbiol Rev* 24:263-290

Supplementary Tables

Table 1 Regression coefficients for biomass production by *H. boliviensis*

Term	Coef.	SE coef.	<i>t</i> value	<i>P</i> value
Constant	3.19958	0.02187	146.295	<0.0001
x_1	-0.04433	0.01451	-3.055	0.012
x_2	0.09539	0.01451	6.574	<0.0001
x_3	0.14464	0.01451	9.968	<0.0001
$x_1 * x_1$	-0.03257	0.01412	-2.306	0.044
$x_2 * x_2$	-0.10326	0.01412	-7.312	<0.0001
$x_3 * x_3$	-0.05024	0.01412	-3.558	0.005
$x_1 * x_2$	-0.02125	0.01896	-1.121	0.289
$x_1 * x_3$	0.02125	0.01896	1.121	0.289
$x_2 * x_3$	0.01125	0.01896	0.593	0.566
$R^2 = 0.956$ $R^2(adj) = 0.917$				

Table 2 Analysis of variance (ANOVA) for biomass production by *H. boliviensis*

Source of Variation	Sum of Squares	Degrees of Freedom	Mean Square	<i>F</i> value	<i>P</i> value
Regression	0.627220	9	0.069691	24.24	<0.0001
Linear	0.436848	3	0.145616	50.64	<0.0001
Square	0.182135	3	0.060712	21.11	<0.0001
Interaction	0.008237	3	0.002746	0.95	0.451
Residual Error	0.028755	10	0.002876		
Lack of fit	0.019755	5	0.003951	2.20	0.204
Pure error	0.009000	5	0.001800		
Total	0.655975	19			

Table 3 Regression coefficients for ectoine production by *H. boliviensis*

Term	Coef.	SE coef.	<i>t</i> value	<i>P</i> value
Constant	1.21	0.01611	75.124	<0.0001
x_1	0.08429	0.01139	7.400	<0.0001
x_2	0.12210	0.01139	10.72	<0.0001
$x_1 * x_1$	-0.17004	0.01274	-13.351	<0.0001
$x_2 * x_2$	-0.0625	0.01274	-4.908	0.003
$x_1 * x_2$	-0.04750	0.01611	-2.949	0.026
$R^2 = 0.984, R^2(adj) = 0.97$				

Table 4 Analysis of variance (ANOVA) for ectoine production by *H. boliviensis*

Source of Variation	Sum of Squares	Degrees of Freedom	Mean Square	<i>F</i> value	<i>P</i> value
Regression	0.375474	5	0.075095	72.37	<0.0001
Linear	0.176068	2	0.088034	84.83	<0.0001
Square	0.190381	2	0.095190	91.73	<0.0001
Interaction	0.009025	1	0.009025	8.70	0.026
Residual Error	0.006226	6	0.001038		
Lack of fit	0.004826	3	0.001609	3.45	0.168
Pure error	0.001400	3	0.000467		
Total	0.381700	11			

V

High productivity of ectoines by *Halomonas boliviensis* using a combined two-step fed-batch culture and milking process

Doan Van- Thuoc^{a,b}, Héctor Guzmán^{a,c}, Jorge Quillaguamán^c, Rajni Hatti-Kaul^{a,*}

^a*Department of Biotechnology, Center for Chemistry and Chemical Engineering, Lund University, P.O. Box 124, SE-221 00 Lund, Sweden.*

^b*Department of Micro-biotechnology, Faculty of Biology, Hanoi National University of Education, 136 Xuan Thuy, Cau Giay, Hanoi, Viet Nam.*

^c*Centro de Biotecnología, Facultad de Ciencias y Tecnología, Universidad Mayor de San Simón, Cochabamba, Bolivia.*

*Corresponding author: E-mail: : Rajni.Hatti-Kaul@biotek.lu.se

Phone: +46 46 222 4840

Fax: + 46 46 222 4713

Abstract

A process comprising two-step fed-batch cultivation has been investigated for the production of ectoines using the moderate halophile *Halomonas boliviensis* DSM 15516. The first cultivation was performed under optimal condition for cell growth and resulted in cell mass concentration of $41 \pm 2 \text{ g l}^{-1}$ after 24 h of cultivation. During the second cultivation at higher salt concentration, accumulation of ectoines increased while cell mass decreased with increasing salt concentration. Maximum productivity of total ectoines reached was $10 \text{ g l}^{-1} \text{ d}^{-1}$ with ectoine concentration of 6 g l^{-1} and hydroxyectoine concentration of 8 g l^{-1} after 9 h of cultivation at 18.5 % NaCl, which is among the highest reported so far. *H. boliviensis* cells were further recycled for the production process after releasing the ectoines. About 75% of the accumulated ectoines were released by subjecting the cells to hypoosmotic shock. On subsequent, reincubation in a medium containing higher salt concentration the cells were able to resynthesize the ectoines resulting in a global productivity of $11.1 \text{ g l}^{-1} \text{ d}^{-1}$, and ectoine and hydroxyectoine productivities of $9.1 \text{ g l}^{-1} \text{ d}^{-1}$ and $2.0 \text{ g l}^{-1} \text{ d}^{-1}$, respectively.

Keywords: fed-batch cultivation; ectoine; hydroxyectoine; *Halomonas boliviensis*

Introduction

Halophilic microorganisms grow optimally at NaCl concentrations of 5 % (w/v) or higher in the environment (Oren 2008). Halophiles have evolved certain metabolic strategies to withstand these high salt concentrations. Most haloarchaea collect cations such as K^+ in concentrations equivalent to the extracellular Na^+ , whilst most halophilic eukaryotes and bacteria store organic compounds such as amino acids, amino acid derivatives, sugars or other polyols, that do not interfere significantly with the regular metabolism of the cells, and that help to counteract the osmotic stress caused by NaCl to the cells, thus behaving as osmolytes (Roberts 2005; Oren 2008). The osmolytes contribute to maintain turgor pressure, cell volume, and concentration of electrolytes in the cells (Roberts 2005). Bacterial species within the family *Halomonadaceae* survive at extraordinarily high NaCl concentration (up to 32 % w/v) by synthesizing mainly ectoine and hydroxyectoine – also called ectoines - as osmolytes. However ectoines are also found in many other halotolerant and halophilic bacterial groups (Roberts 2005). The ectoines also protect the cells against heating, desiccation and freezing (Kuhlmann et al. 2008; Roberts 2005; Vargas et al. 2008). The amount of osmolytes stored in the cells increases as the stresses enhance, and diminishes by release of the osmolytes from the cells when the environment conditions are optimal for cell growth (Kuhlmann et al. 2008; Roberts 2005; Vargas et al. 2008).

The protective action of ectoines on biological compounds (e.g. enzymes, DNA, cell membranes, antibodies and whole cells) highlights their commercialization potential in fields related to molecular biology, agriculture,

food processing, biotechnology, pharmacy and medicine (Lippert and Galinski 1992; Louis et al. 1994; Göller and Galinski 1999; Knapp et al. 1999). Currently, production of ectoine is performed by a process named “bacterial milking”, involving repetitive cycles of a fed-batch fermentation of *Halomonas elongata* at 15% (w/v) NaCl to allow ectoine accumulation in the cells followed by osmotic downshock at 3% (w/v) to release and collect the osmolyte from the cells (Sauer and Galinski 1998). Some other alternative processes for production of osmolytes are based on fed-batch fermentation of *Brevibacterium epidermis* (Onraedt et al. 2005), and continuous synthesis and excretion of osmolytes by recombinant *E. coli* strains (Schubert et al. 2007; Bestvater et al. 2008) or the wild type strain of *Halomonas salina* (Zhang et al. 2009). The latter system has resulted in the highest volumetric productivities of ectoine. On the other hand, a fed-batch-microfiltration system employing *Marinococcus* M52 provided elevated concentrations of hydroxyectoine after transforming the ectoine synthesized by the organism to hydroxyectoine during its stationary phase of growth (Schiraldi et al. 2006).

Recent studies on members of the family *Halomonadaceae*, i.e. *Halomonas halodenitrificans*, *Halomonas halodeneurihalina*, *H. salina*, *H. elongata* (Mothes et al. 2008) and *Halomonas boliviensis* (Guzmán et al. 2009) have demonstrated the ability to synthesize ectoine and poly(3-hydroxybutyrate) (PHB), a polyester in the same process. The process designed for *H. boliviensis* comprises a two-step fed-batch culture in which the first fed-batch step is used to attain high cell densities, whereas the second to induce the accumulation of the products in

the cells (Guzmán et al. 2009). This procedure led to high productivities of ectoine (up to 3.4 g l⁻¹ d⁻¹), similar to those described for *H. elongata* and *B. epidermis* (Guzmán et al. 2009). Nevertheless, the entire potential of *H. boliviensis* as ectoines producer was not utilized since the synthesis of ectoine and PHB require acetyl-CoA as intermediate, hence the catabolic routes to these products may influence each other (Guzmán et al. 2009).

The present work involves a study on increasing the production of ectoine and hydroxyectoine by *H. boliviensis* using the two-step fed-batch cultivation system coupled with bacterial milking.

Materials and methods

Bacterial strain, maintenance- and cultivation media

Halomonas boliviensis LC1^T (=DSM 15516^T) was maintained on HM (medium for moderate halophiles) agar plates at 4 °C (Quillaguamán et al. 2004), containing (% w/v): NaCl, 4.5; MgSO₄·7H₂O, 0.025; CaCl₂·2H₂O, 0.009; KCl, 0.05; NaBr, 0.006; peptone, 0.5; yeast extract, 1.0; glucose, 0.1; and granulated agar, 2.0. The pH of the medium was adjusted to 7.5 with 3 M NaOH.

The culture media for production of osmolytes used in this study are shown in Table 1. Glucose, KH₂PO₄ and monosodium glutamate were sterilized separately. The pH of the media was adjusted to 7.5 using 5M HCl or 5M NaOH solutions.

Determination of ectoines release and cell survival after osmotic downshock

H. boliviensis was grown in batch medium containing 15 % (w/v) NaCl at 30 °C for 30 hours (Guzmán et al. 2009). Thirty milligrams biomass was collected from the culture broth (3

ml) by centrifugation at 6000 g for 10 min. The cells were suspended in 1 ml distilled water and in 1 ml of solutions containing 1.5 and 3 % (w/v) NaCl, respectively and incubated at 25 °C with shaking at 200 rpm for 30 min for ectoines release. The suspensions were then centrifuged at 6000 g for 10 min. The supernatants containing osmolytes were analyzed by HPLC. Release of ectoines was calculated as the percentage of the ectoine amount released from the cells with respect to that stored in the cells before the osmotic downshock. The cell pellet obtained after centrifugation was suspended in a 15 % (w/v) NaCl sterile solution, serially diluted in the same solution and subsequently plated on solid HM medium. Cells obtained from the culture broth without being subjected to osmotic downshock were similarly suspended, diluted and plated on HM medium. *H. boliviensis* colonies on the plates were counted after 2 days of cultivation at 30 °C. The percentage of cell survival was calculated based on the ratio of the number of colonies found after the osmotic downshock with respect to the number of colonies formed from the cells that did not experience the downshock.

Ectoines production by two-step fed-batch cultivations

H. boliviensis was first grown in 150 ml of seed culture medium (Table 1) in 1 l shake-flask, on a rotary shaker (New Brunswick Scientific, NJ, USA) at 30 °C and 200 rpm for 13 h (OD₆₀₀ = 2.5 ± 0.1). The medium was then used to inoculate 1.35 l of fed-batch medium with 45 g l⁻¹ NaCl (Table 1) in a 2-L bioreactor (Voyager, Luton, UK) as first fed-batch step of cultivation. Cells were cultivated for 24 h and subsequently harvested from the culture broth by centrifugation at 5 500 g for 10 min at 4 °C, and used to inoculate 1.4 l of fed-batch medium

with a higher NaCl concentrations (12.5 %, 15.5 %, and 18.5 % w/v, respectively) to initiate a second fed-batch culture in which production of ectoines was triggered. The samples were taken every 3 h for biomass and ectoines analysis.

Fed-batch cultivations were performed under the following conditions: temperature was kept constant during the cultivation at 35 °C and the pH was maintained between 7.5-7.8 by adding 5 M HCl/NaOH. Stirring velocity and aeration were initially set at 700 rpm and 1 l min⁻¹, and were increased during the fermentation to maintain the dissolved oxygen concentration above 20 %. The highest speed for agitation and air inflow used were 1100 rpm and 5 l min⁻¹, respectively. Glucose concentration was maintained at about 20 g l⁻¹ by adjusting the feed solution (Table 1) when a decrease in the glucose concentration was detected by off-line analysis. Monosodium glutamate (MSG) was also kept at 20 (± 2) g l⁻¹ by using an HPLC off-line analysis and adding a 500 g l⁻¹ MSG solution during the first fed-batch fermentation. For the second fed-batch step, MSG was kept constant only for 6 h. Polypropylene glycol 2025 or pure silicon oil was added as antifoam when required.

Two-step fed-batch culture coupled to bacterial milking

H. boliviensis was grown in two-step fed-batch system as described above. After 12 h of the second fed-batch, using a medium with 15 % (w/v) NaCl, cells were harvested by centrifugation at 5000 g for 10 min at 4 °C and the pellet was re-suspended in a 1.5 liters of a 1.5 % (w/v) NaCl solution (1.5 l) to induce the release of ectoines. The cells were allowed to stand for 30 min at 25 °C with agitation at 200 rpm, and subsequently harvested by centrifugation (5 500 g, 10 min, 4 °C). The supernatant containing ectoines was analyzed by HPLC, the pellet was transferred to the fed-batch medium containing 15 % (w/v) NaCl and incubated again for further 15 h under the same conditions used for the second fed-batch step. In all cultures, samples were taken every 3 h for biomass and ectoines analysis.

Analytical methods

Cell dry weight (CDW) was determined as the biomass obtained after centrifuging 3 ml of the culture broth at 2000 g for 15 min, washing the cell pellet once with 3 ml of a solution with the same NaCl concentration as the one employed for the production of ectoines, and drying the pellet at 70 °C until constant weight was obtained. All analyses were performed in

Table 1. Media composition for ectoines production by *H. boliviensis* in bioreactor

Component	Seed culture g l ⁻¹	Fed-batch medium g l ⁻¹	Feed solution (first step) g l ⁻¹	Feed solution (second step) g l ⁻¹
Glucose	10	20	500	500
NaCl	45	V	45	V
NH ₄ Cl	2.3	4.0	40	10
MgSO ₄ •7H ₂ O	2.5	6.94	69.4	17.35
K ₂ HPO ₄	0.55	3.54	35.4	8.85
FeSO ₄ •7H ₂ O	0.005	0.01	0.1	0.025
Tris	15	-	-	-
Glutamine	3	-	-	-
Monosodium glutamate	-	20	-	-

V: Component concentration was varied in different experiments

triplicate.

Glucose concentration was analyzed by Accu-Chek sensors (Roche, Mannheim, Germany).

Extraction of compatible solutes for ectoine analysis was performed as described previously (Kunte et al., 1993). Concentrations of ectoines and MSG were determined by HPLC analysis (Onraedt et al. 2005), using a Perkin-Elmer HPLC system with an Aminex HPX-87C column (Biorad) and a UV detector at 70 °C, and monitoring the compounds at 210 nm. Calcium chloride (5 mM) was used as mobile phase at a flow rate of 0.3 ml min⁻¹. The intracellular ectoines content (ectoines per biomass, g g⁻¹ of CDW) and the total ectoines concentration (ectoines per liter culture broth, g l⁻¹) were calculated according to standard procedures (Kunte et al. 1993).

Results and discussion

Osmotic downshock effect on the release of ectoines by H. boliviensis and survival rates of the cells

H. boliviensis synthesises ectoine and hydroxyectoine as osmolytes as NaCl concentration increases in the cells' environment (Guzmán et al. 2009). To design a process for osmolytes production by *H. boliviensis*, it was considered that the strain should release the intracellularly accumulated ectoines efficiently when subjected to a hypoosmotic shock and should be able to re-synthesize the osmolytes once the cells are transferred back to a hyperosmotic medium (Sauer and Galinski 1998, Nagata et al. 2008). Therefore the amount of released ectoines and the survival of *H. boliviensis* cells after osmotic downshock were investigated (Fig. 1a,b). As shown in Fig. 1a, about 90 % of the ectoines

was released after 30 min when the cells were suspended in distilled water after being cultured at 15 % (w/v) NaCl. As NaCl concentration increased in the osmotic downshock solution to 1.5 and 3 % (w/v) the amount of ectoines liberated from the cells diminished to 76 and 64 %, respectively. A similar result was found when *H. elongata* was taken from 15 % to 3 % NaCl in the bacterial milking process (Sauer and Galinski 1998). On the other hand, viability of the cells at 3 % (w/v) NaCl is higher - 80 % with respect to that in the culture broth at 15 % (w/v) NaCl, while the cell survival decreased to 62 % at 1.5 % (w/v) NaCl and 50 % in distilled water (Fig 1b).

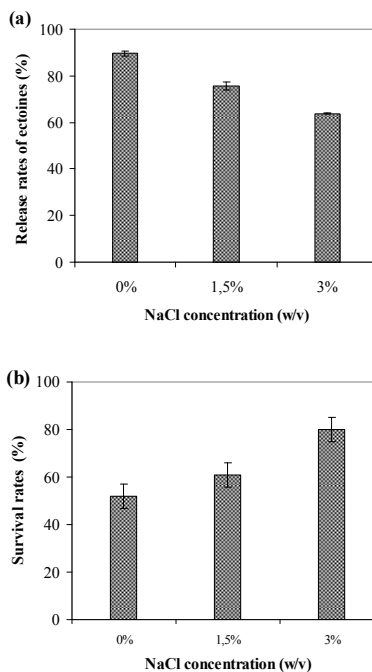

Fig. 1 Effect of NaCl concentration in the downshock medium on release rates of (a) ectoine and (b) survival rates of *H. boliviensis*. Experimental details are stated in the text

A solution of 1.5 % (w/v) NaCl was selected to continue the process in fermentors since high release of intracellular ectoines enhances the productivity of osmolytes in the process, and high cell density could be obtained by multiplication of the viable cells under optimal growth conditions.

Production of ectoines by two-step fed-batch culture at different NaCl concentrations

In order to get high productivity of ectoines, fed-batch cultivations were performed in two steps. The first fed-batch culture was performed under optimal conditions for the growth of *H. boliviensis* and yielded $41 (\pm 2) \text{ g l}^{-1}$ biomass (dry weight) after 24 h. The biomass was harvested by centrifugation and transferred to a second fed-batch culture with fresh medium containing a higher salt concentration (12.5 %, 15.5 %, and 18.5 %, respectively) to induce the accumulation of ectoines. As shown in Fig. 2, *H. boliviensis* rapidly synthesized ectoines to counteract the lower water activity caused by high salt concentration in the medium. At NaCl concentrations of 12.5 % and 15.5 % NaCl, the total ectoines content in the cells increased from about $9.5 \pm 0.5 \text{ wt}\%$ to $14.5 \text{ wt}\%$ and $19.8 \text{ wt}\%$, respectively, until 6 h of cultivation after which it remained constant until 12 h and then decreased (Fig. 2a,b). At 18 % (w/v) NaCl, *H. boliviensis* accumulated much higher amount of ectoines (27.8 %); the increase was attributed to the increase in hydroxyectoine content. The maximum ectoine content (14.8 %) was similar to that found at 12.5 % (w/v) NaCl after 3 h of cultivation which coincided with the onset of hydroxyectoine accumulation until 6 h (Fig. 2c). This observation suggests that the synthesis of hydroxyectoine by *H. boliviensis* was regulated by amount of ectoine. As proposed in previous reports, the synthesis of hydroxyectoine may occur directly from

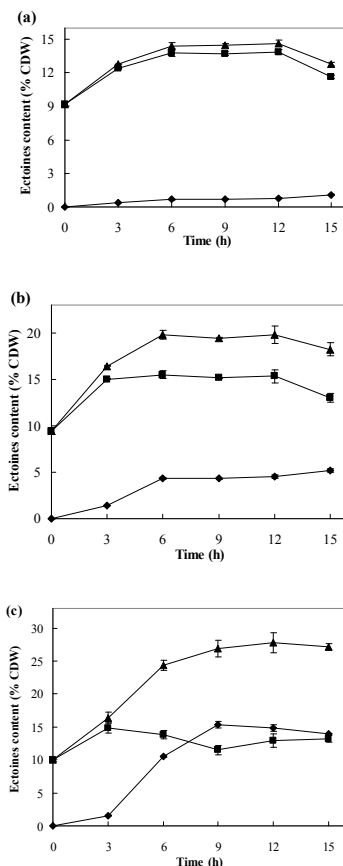

Fig. 2 Production of compatible solute during the second-step fed-batch cultivation at NaCl concentrations of (a) 12.5% NaCl, (b) 15.5% NaCl, and (c) 18.5% NaCl. The symbols denote (■) ectoine, (◆) hydroxyectoine, and (▲) total ectoines content, respectively. Cell mass concentration of $41 \pm 2 \text{ g l}^{-1}$ obtained from a previous fed-batch culture grown at 4.5 % (w/v) NaCl was used to initiate this culture

ectoine or from one of its biosynthetic intermediates, N γ -acetyl-L-2,4-diaminobutyrate (NADA) (Louis and Galinski 1997; Göller et al. 1998; Cánovas et al. 1999; García-Esteba et al. 2006). If ectoine is used as a precursor for the synthesis of hydroxyectoine, the presence

of high ectoine level would lead to an activation of the ectoine hydroxylase, the enzyme catalysing the conversion of ectoine to hydroxyectoine. If the synthesis of hydroxyectoine occurs via the intermediate, the high ectoine level may result in an inhibition of ectoine synthase, the enzyme catalysing the synthesis of ectoine from NADA and the latter may be metabolised further to hydroxyectoine via 3-hydroxy-N γ -acetyl-L-2,4-diaminobutyrate.

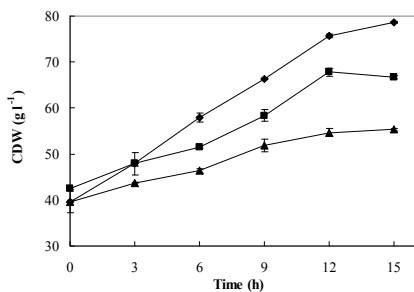

Fig. 3 Effect of NaCl concentration on cell mass concentration during the second fed-batch cultivation. Cell mass concentration of $41 \pm 2 \text{ g l}^{-1}$ obtained from a previous fed-batch culture grown at 4.5 % (w/v) NaCl was used to initiate this culture. Symbols: (◆) 12.5% NaCl, (■) 15.5% NaCl, (▲) 18.5% NaCl

As expected, high salt concentration in the medium inhibited *H. boliviensis* cell growth. The maximum cell dry weight was 78.6 g l^{-1} at 12.5 % NaCl after 15 h of cultivation, and decreased to 68 and 55 g l^{-1} at 15.5 % and 18.5 % (w/v) NaCl, respectively (Fig. 3). *H. boliviensis* reached higher CDW in shorter time (36.5-39.5 h) than that reported for *H. elongata* (40 g l^{-1} after 110 h at 15 % NaCl), *B. epidermis* (50 g l^{-1} after 90 h at 5.8 % NaCl), and *Marinococcus* strain M52 (56 g l^{-1} after 120 h at 10 % NaCl) (Sauer and Galinski 1998; Onraedt et al. 2005; Frings et al. 1995).

For calculating the ectoines maximum productivity, a total production time of 24 h for the first fed-batch step, 0.5 h for harvesting and re-suspending the cells in the medium with higher NaCl concentration, and the culture time for the second fed-batch were considered. The maximum ectoine productivity of $6.9 \text{ g l}^{-1} \text{ d}^{-1}$ was obtained for cultivation at 12.5% NaCl, whilst the maximum hydroxyectoine productivity was $5.7 \text{ g l}^{-1} \text{ d}^{-1}$ at 18.5 % NaCl. The maximum total ectoines productivity of $10 \text{ g l}^{-1} \text{ d}^{-1}$ was attained at 18.5 % NaCl with a final concentration of ectoine and hydroxyectoine at 6 g l^{-1} and 8 g l^{-1} , respectively (data not shown). The results obtained from these experiments are comparable with those of the highest reported so far for ectoine production (Sauer and Galinski 1998; Onraedt et al. 2005; Zhang et al. 2009) and for hydroxyectoine production (Frings et al. 1995). The ectoine productivity obtained by *H. boliviensis* ($6.9 \text{ g l}^{-1} \text{ d}^{-1}$) is much higher than that obtained by *B. epidermis* ($2 \text{ g l}^{-1} \text{ d}^{-1}$) and *H. elongata* ($5.3 \text{ g l}^{-1} \text{ d}^{-1}$ -calculated for nine cycles) and lower than that reported for *H. salina* DSM 5928 ($7.9 \text{ g l}^{-1} \text{ d}^{-1}$). On the other hand, the productivity of hydroxyectoine by *H. boliviensis* ($5.7 \text{ g l}^{-1} \text{ d}^{-1}$) is about four fold of highest reported so far for *Marinococcus* M52 ($1.5 \text{ g l}^{-1} \text{ d}^{-1}$).

Two-step fed-batch culture coupled to milking cycles for production of the ectoines

The ability of halophilic microorganism to accumulate osmolytes at high salt concentrations and release them when transferred to medium with lower content of salt ions has been exploited in industrial production using the bacterial milking process (Sauer and Galinski 1998). Therefore, we decided to link the two-step fed-batch culture to a cycle of extraction of

ectoines and regeneration of *H. boliviensis* cells for further induction of ectoines synthesis. After 12 h of cultivation in the second fed-batch medium containing 15 % (w/v) NaCl (cycle 1), the cells (62.4 g l^{-1}) accumulated 19 wt% ectoines, composed of 15.4 wt% ectoine and 3.6 wt% hydroxyectoine. The concentration of ectoines was 11.9 g l^{-1} , (with 9.6 g l^{-1} ectoine and 2.3 g l^{-1} hydroxyectoine) (Fig 4a,b). The cells were collected and re-suspended in 1.5 litres of 1.5 % (w/v) NaCl to induce the efflux of ectoines from the cells. After 30 min of osmotic downshock, 7.7 g l^{-1} of ectoine and 1.2 g l^{-1} of hydroxyectoine were released (data not shown). Subsequently, the cells were harvested and re-suspended in the fed-batch medium containing 15% NaCl for further growth (cycle 2). The total ectoines content reached after 12 h was 17.2 wt% with ectoine content of 14.3 wt% and hydroxyectoine content of 2.9 wt%, and the concentration of total ectoines was 10.7 g l^{-1} with ectoine at 8.9 g l^{-1} and hydroxyectoine at 1.8 g l^{-1} (Fig. 4a,b). Furthermore, the cell density recovered was 62.1 g l^{-1} , which was similar to the previous cycle (data not shown). The lower ectoines content and -concentration in the second cycle could be explained by a relatively higher PHB content (30.6 wt% as compared to 23 wt% for the first cycle) accumulated by the cells (data not shown).

The time required to perform one cycle at 15% NaCl was only 12 - 15 h with recovery of about 75 % of the ectoines after osmotic downshock, as compared to 22 h cycle time and 67 % ectoine recovery reported for *H. elongata* (Sauer and Galinski 1998). The global ectoines productivity for the process was $11.1 \text{ g l}^{-1} \text{ d}^{-1}$, while productivities of ectoine and hydroxyectoine were $9.1 \text{ g l}^{-1} \text{ d}^{-1}$

and $2.0 \text{ g l}^{-1} \text{ d}^{-1}$, respectively. These productivities are the highest reported so far.

This work demonstrates *Halomonas boliviensis* to be a promising alternative for the production of osmolytes. The organism showed the ability to revive and continue the synthesis of ectoines after being subjected to hypo-osmotic shock. Research on improvements of the cycling process and culture conditions is on going.

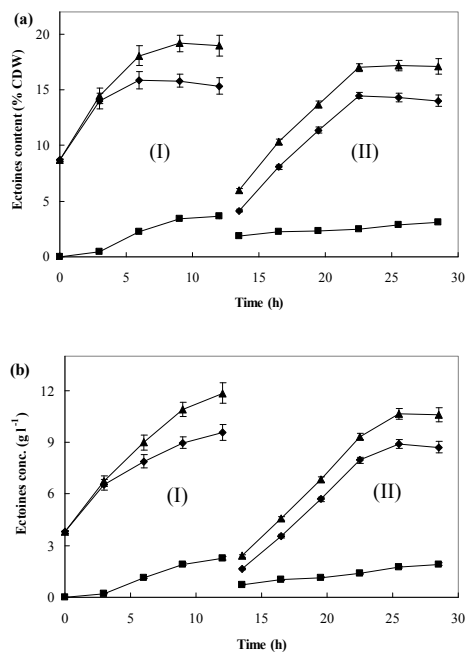

Fig. 4 Ectoines content (a) and -concentration (b) during first (I) and second (II) production cycles using *H. boliviensis* cells. The cells to initiate the first cycle were obtained from a previous fed-batch culture grown at 4.5 % (w/v) NaCl for 24 h. In between cycle I and II, the cells were subjected to osmotic downshock by suspending in 1.5 % NaCl solution for the recovery of the ectoines. Symbols: (\blacklozenge)ectoine, (\blacksquare) hydroxyectoine, (\blacktriangle) ectoines

Acknowledgement

The authors would like to thank the Swedish International Development Cooperation Agency (Sida) for supporting this work.

References

- Bestvater, T., Louis, P., Galinski, E. A., 2008. Heterologous production in *Escherichia coli*: By-passing the metabolic bottle-neck. *Saline Systems* 4:12 doi:10.1186/1746-1448-4-12.
- Göller, K., Galinski, E.A., 1998. Protection of a model enzyme (lactate dehydrogenase) against heat, urea and freeze-thaw treatment by compatible solutes additives. *J. Mol. Catal B: Enzymatic* 7, 37-45.
- Guzmán, H., Van-Thuoc, D., Martín, J., Hatti-Kaul, R., Quillaguamán, J., 2009. A process for the production of ectoine and poly(3-hydroxybutyrate) by *Halomonas boliviensis*. *Appl. Microbiol. Biotechnol.* 84, 1069-1077.
- Kuhlmann, A.U., Bursy, J., Gimpel, S., Hoffmann, T., Bremer, E., 2008. Synthesis of the compatible solute ectoine in *Virgibacillus pantothenicus* is triggered by high salinity and low growth temperature. *Appl. Environ. Microbiol.* 74, 4560-4563.
- Kunte, H.J., Galinski, E.A., Trüper, H.G., 1993. A modified FMOC-method for the detection of aminoacid type osmolytes and tetrahydropyrimidines (ectoines). *J. Microbiol. Meth.* 17, 129-136.
- Lippert, K., Galinski, E.A., 1992. Enzyme stabilization by ectoine-type compatible solutes: protection against heating, freezing and drying. *Appl. Microbiol. Biotechnol.* 37, 61-65.
- Louis, P., Trüper, H.G., Galinski, E.A., 1994. Survival of *Escherichia coli* during drying and storage in the presence of compatible solutes. *Appl. Microbiol. Biotechnol.* 41, 684-688.
- Mothes, G., Schubert, T., Harms, H., Mawkow, T., 2008. Biotechnological coproduction of compatible solutes and polyhydroxyalkanoates using the genus *Halomonas*. *Eng. Life Sci.* 8, 658-662.
- Onraedt, A.E., Wlcarius, B.A., Soetaert, W.K., Vandamme, E.J., 2005. Optimization of ectoine synthesis through fed-batch fermentation of *Brevibacterium epidermis*. *Biotechnol. Prog.* 21, 1206-1212.
- Oren, A., 2008. Microbial life at high salt concentrations: phylogenetic and metabolic diversity. *Saline Systems* 4:2. doi:10.1186/1746-1448-4-2
- Quillaguamán, J., Hatti-Kaul, R., Mattiasson, B., Alvarez, M.T., Delgado, O., 2004. *Halomonas boliviensis* sp. nov., an alkalitolerant, moderate halophile bacterium isolated from soil around a Bolivian hypersaline lake. *Int. J. Syst. Evol. Microbiol.* 54, 721-725.
- Roberts, M.F., 2005. Organic compatible solutes of halotolerant and halophilic microorganism. *Saline Systems (On-line Journal)*. 1:5 DOI: 10.1186/1746-1448-1-5.
- Sauer, T., Galinski, E.A., 1998. Bacterial milking: A novel bioprocess for production of compatible solutes. *Biotechnol. Bioeng.* 57, 306-313.
- Schiraldi, C., Maresca, C., Catapano, A., Galinski, E.A., De Rosa, M., 2006. High yield cultivation of *Marinococcus* M52 for production and recovery of hydroxyectoine. *Res. Microbiol.* 157, 693-699.
- Schubert, T., Maskow, T., Benndorf, D., Harms, H., Breuer, U. 2007. Continuous synthesis and excretion of the compatible solute ectoine by a transgenic, nonhalophilic bacterium. *Appl. Environ. Microbiol.* 73, 3343-3347.
- Vargas, C., Argandoña, M., Reina-Bueno, M. et al., 2008. Unravelling the adaptation

responses to osmotic and temperature stress in *Chromohalobacter salexigens*, a bacterium with broad salinity tolerance. Saline Systems 4:14 doi:10.1186/1746-1448-4-14.

Zhang, L., Lang, Y., Nagata, S., 2009. Efficient production of ectoine using ectoine-excreting strain. Extremophiles 13, 717-724.

Enzyme stabilization by ectoine and hydroxyectoine at high pH

Doan Van-Thuoc^{a,b}, Suhaila Hashim^a, Rajni Hatti-Kaul^a, Gashaw Mamo^{a*}

^a Department of Biotechnology, Center for Chemistry and Chemical Engineering, Lund University, P.O. Box 124, SE-221 00 Lund, Sweden.

^b Department of Micro-biotechnology, Faculty of Biology, Hanoi National University of Education, 136 Xuan Thuy, Cau Giay, Hanoi, Viet Nam.

*Corresponding author: E-mail: gashaw.mamo@biotek.lu.se

Telephone: +46 46 2224741

Fax: +46 46 2224713

Abstract

Compatible solutes are small, soluble organic compounds that have the ability to stabilize proteins against various stress conditions. In this study, the protective effect of ectoines against pH stress is examined using a recombinant xylanase from *Bacillus halodurans* as a model. Ectoines improved the enzyme stability at low (4.5 and 5.0) and high pH (11 and 12); stabilization effect of hydroxyectoine was superior to that of ectoine and trehalose. In the presence of hydroxyectoine, residual activity increased from about 45 % to 86 % at pH 5 and from 33 % to 89 % at pH 12. When the xylanase was incubated at 65 °C for 5 hours with 50 mM hydroxyectoine at pH 10, about 40 % of the original activity was maintained while no residual activity was detected in the absence of additives or in the presence of ectoine or trehalose. The xylanase activity was stimulated in the presence of 25 mM ectoines and a gradual decrease with increase in concentration was observed reaching 85 % and 90 % with 100 mM hydroxyectoine and ectoine, respectively. The thermal unfolding of the enzyme in the presence of the compatible solutes has shown a modest increase in T_m (0.5 - 0.9 °C) but a larger increase in calorimetric enthalpy.

Keywords: compatible solutes; ectoine; hydroxyectoine; xylanase; protein stabilization; differential scanning calorimetry

1. Introduction

Organisms adapted to thrive in extreme environments have evolved strategies that allow them to survive and flourish in the harsh ecology they inhabit. Halophiles, a group of extremophiles growing in high salt environment have two adaptive strategies to cope with high external salt concentration. One of the strategies, accumulation of inorganic ions, is used by members of the extremely halophilic *Archaea* of family *Halobacteriaceae* and the *Bacteria* order *Haloanaerobiales* (Oren

2002; Empadinhas and da Costa 2008). The other strategy of osmoadaptation involves the accumulation of small, highly soluble organic compounds known as compatible solutes or extremolytes or osmolytes and found in the vast majority of microorganisms (Oren 1999; 2006; 2008; Roberts 2005). Today, several organisms belonging to different taxonomic groups of *Archaea*, *Bacteria* and *Eukarya* are known to produce and/or accumulate one or more types of compatible solutes. These compounds are zwitterionic, noncharged or anionic and are represented by various classes of organic

compounds including polyols, sugars, amino acids, betaines, ectoines and their derivatives (Roberts 2005; Lentzen and Schwarz 2006). The diversity of these compounds has been increasing as more organisms, especially thermophilic and hyperthermophilic *Bacteria* and *Archaea*, have been examined (Empadinhas and da Costa 2006).

Compatible solutes are not only protecting cells but also proteins and other labile molecules from the deleterious effects of environmental stresses. Protection of cells, enzymes and DNA by compatible solutes against the effect of heat, freezing and desiccation has been proven (Lippert and Galinski 1992; Louis et al. 1994; Welsh 2000) and this has promoted a growing interest in using these solutes in various biotechnological applications. Particularly, ectoines (ectoine and its hydroxy derivative, hydroxyectoine) have attracted a great deal of attention and have been studied extensively.

So far, many studies have demonstrated the remarkable ability of ectoines as protective agents for enzymes against some stress conditions. Lactate dehydrogenase and phosphofructokinase are protected from the denaturing effects of heating, freezing, freeze-thawing and drying (Lippert and Galinski 1992; Göller and Galinski 1999). Compatible solutes have also been reported to protect proteins against oxidative damage (Andersson et al. 2000) and proteolysis (Kolp et al. 2006).

pH is a very important factor in biological systems. It affects the biochemical reaction rates and stability of biological machineries like proteins and other macromolecular structures having profound importance to the very existence of life. Particularly, enzymes, the biological catalysts in myriad biochemical

reactions of life are known to be active and stable only within a range of pH, often around neutrality. The great majority of enzymes are neither active nor stable at 'extreme' pH conditions. On the other hand, a variety of biotechnological applications require the use of enzymes that are operationally stable at extreme pH. For example, kraft pulping requires xylanases that are active and stable under the pulping condition, i.e. high pH and high temperature (Kulkarni et al. 1999). Similarly, enzymes for detergent formulation and leather tanning should be active and stable at high pH (Horikoshi 1999). In this work, the protective effect of ectoines against the effect of high pH stress is reported using an alkaline active xylanase from *Bacillus halodurans* as a model.

2. Materials and methods

2.1. Materials

Ectoine and hydroxyectoine were purchased from Fluka (Buchs, Switzerland). Birchwood xylan and trehalose were obtained from Sigma (Sigma GmbH, Germany). A recombinant xylanase from an alkaliphilic *Bacillus halodurans* S7 was purified following the procedure described in a previous report to a preparation with a specific activity of 342 U/mg (Mamo et al. 2006).

2.2. Assay of xylanase activity

The xylanase activity was determined based on the release of reducing sugar from xylan using the dinitrosalicylic acid (DNS) method (Miller 1959). A mixture of appropriately diluted enzyme and 1 % (w/v) birchwood xylan dissolved in 50 mM glycine-NaOH buffer, pH 9 was incubated at 70 °C for 10 minutes, and the reaction was stopped by adding DNS reagent and placing the tubes in a boiling water

bath for 5 min. Subsequently, the tubes were cooled in cold water for 10 min and absorbance of the samples read at 540 nm. A calibration curve was made using xylose as the standard. One unit of xylanase activity was defined as the amount of enzyme releasing 1 μmol reducing sugar per min under the standard assay conditions.

2.3. Effect of compatible solutes on the pH and thermal stability of xylanase

The enzyme (2.2 $\mu\text{g/ml}$) was incubated in 50 mM sodium acetate buffer (pH 4.5 and 5) or with 50 mM glycine-NaOH buffer (pH 11 and 12) with 50 mM ectoine, hydroxyectoine, or trehalose, respectively, at 50 $^{\circ}\text{C}$ for 10 h followed by determination of residual activity.

The enzyme (2.2 $\mu\text{g/ml}$) was also incubated in 50 mM glycine-NaOH buffer, pH 10 with 50 mM ectoine, hydroxyectoine or trehalose at 65 $^{\circ}\text{C}$. Samples were taken at different time intervals and residual xylanase activity was determined. All analyses were performed in triplicate.

2.4. Differential scanning calorimetry

The effect of ectoine and hydroxyectoine (200 mM), respectively, on the thermal stability of the *B. halodurans* S7 xylanase (13.5 μM) was investigated at pH 9 and 10 using a Microcal VP-DSC instrument (Northampton, MA). All solutions were degassed prior to scanning and scans were performed from 20 $^{\circ}\text{C}$ to 100 $^{\circ}\text{C}$ at a rate of 1 $^{\circ}\text{C}/\text{min}$. The data generated was analysed using OriginTM software. Appropriate buffer scans were subtracted from sample scans prior to determination of molar excess heat capacities, C_p , by normalising the experimental thermograms with enzyme concentration and volume of the calorimeter cell. The apparent denaturation temperature, T_m , was determined

as the temperature corresponding to maximum C_p , (C_{pmax}) and the calorimetric enthalpy, ΔH_{cal} , was calculated by integrating the area under the peak. A cubic baseline was subtracted prior to the determination of thermodynamic parameters.

3. Results

3.1. Stabilization of xylanase against the effect of pH and temperature

Both low pH (4.5 and 5) and high pH (11 and 12) conditions at which there is a clear denaturing effect of pH on the enzyme (Mamo et al. 2006), were selected to test the stabilizing effect of the compatible solutes on *B. halodurans* xylanase. After 10 h incubation at 50 $^{\circ}\text{C}$, the enzyme in the absence of additives had completely lost its activity at pH 4.5 while about 30 % of the original was maintained at pH 12, but the enzyme retained higher activity in the presence of the compatible solutes (Fig. 1). Hydroxyectoine provided the highest stability - the residual activity increased from

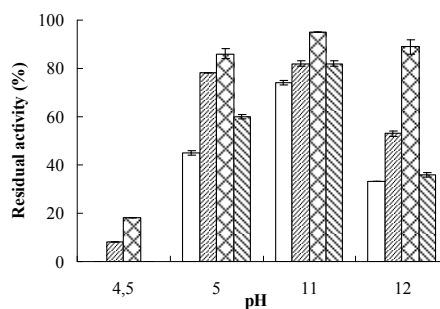

Fig. 1 Protective effect of compatible solutes on *B. halodurans* xylanase at low and high pH values. The enzyme (2.2 $\mu\text{g/ml}$) was incubated in the absence (□), and presence of 50 mM ectoine (▨), hydroxyectoine (▩) and trehalose (▧), respectively, at 50 $^{\circ}\text{C}$ for 10 h and the xylanase residual activity determined. The buffers used were sodium acetate (pH 4.5 and 5), and glycine-NaOH (pH 11 and 12)

about 45 % to 86 % when incubated at pH 5, and 33 % to 89 % at pH 12. In the presence of the ectoines, the enzyme retained 8-18 % of its original activity at pH 4.5. Trehalose provided a little stabilization effect at pH 5 and 11 but not at pH 4.5 and 12.

The effect of the solutes on the stability of the xylanase was also followed at a higher temperature, 65 °C and pH 10. As shown in Fig. 2, only the enzyme sample with 50 mM hydroxyectoine retained 40% of the original activity after 5 h incubation while there was no detectable activity in the other samples.

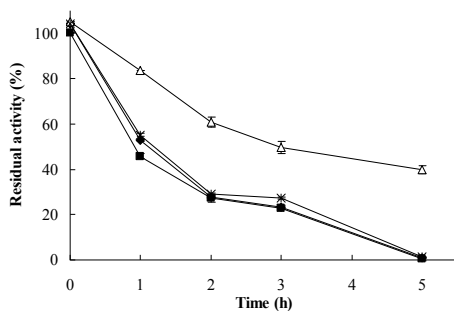

Fig. 2 Effect of the compatible solutes on thermal stability of *B. halodurans* xylanase at pH 10. The enzyme (2.2 µg/ml) was incubated in 50 mM glycine-NaOH buffer, pH 10 with in the absence (■), and presence of 50 mM ectoine (◆), hydroxyectoine (Δ) and trehalose (*), respectively, at 65°C. Samples were withdrawn after every hour and the residual activity of the enzyme was determined

Subsequently, the concentration of the ectoines was varied. As shown in Fig. 3, increased stability of the xylanase was observed right from very low concentration of hydroxyectoine. The residual activity increased to 60 % of the original activity with increasing hydroxyectoine concentration to 300 mM. Ectoine did not provide any stabilizing effect up to a concentration of 150 mM and further

increase in the concentration resulted in a maximum of only about 10 % of the original enzyme activity.

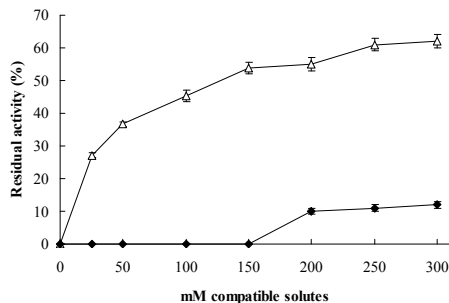

Fig. 3 Effect of the concentration of compatible solutes on the xylanase thermostability. The enzyme (2.2 µg/ml) was incubated in 50 mM glycine-NaOH buffer, pH 10 in the presence of varying concentrations of ectoine (◆) or hydroxyectoine (Δ) at 65 °C for 5 h and the residual activity of the enzyme was measured

3.2. Ectoines' effect on the xylanase activity

The xylanase activity was subsequently determined in the presence of 25 mM compatible solutes at different pH values. There was no apparent effect on the activity when assayed in the presence of ectoines at pH 4.5, while the enzyme activity was found to be stimulated to different degrees in a pH range of 5-12. The maximum increase in activity (44 %) was observed at pH 12 in the presence of hydroxyectoine and trehalose.

The effect of varying concentration of ectoines on the xylanase activity at 70 °C and pH 9 was also investigated. Maximal activity was observed in the presence of 25 mM ectoines, and with increase in concentration there was a gradual decrease in activity reaching 85 % and 90 % of the original activity with 100 mM hydroxyectoine and ectoine, respectively (Fig. 5).

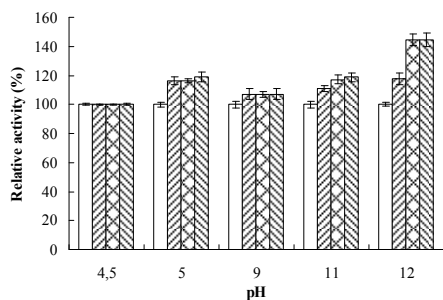

Fig. 4 Effect of compatible solutes on the activity of *B. halodurans* xylanase. The enzyme (2.2 µg/ml) was incubated at 70 °C with 1% (w/v) birchwood xylan dissolved in 50 mM buffer in the absence (□) and presence of 25 mM ectoine (▨), hydroxyectoine (▩) or trehalose (▧), respectively. The buffers used were sodium acetate (pH 4.5 and 5) and glycine-NaOH (pH 9, 11 and 12). For each pH, the enzyme activity without compatible solute is considered as 100 %

3.3. Effect of ectoines on the thermodynamic properties of the xylanase

The presence of ectoines during the thermal unfolding of *B. halodurans* S7 xylanase at pH 9 and 10 resulted in a modest increase in T_m (0.5 - 0.9 °C, Table 1). However, the ectoines led to an increase in ΔH_{cal} - more than two fold increase was seen in the presence of hydroxyectoine at pH 9 and 10 (Table 1). The thermograms generated under these conditions were also significantly broader as compared to the control without hydroxyectoine (Fig. 6).

4. Discussion

Stability of proteins at high pH is of interest both from fundamental and applied perspectives. Protein engineering (Gulich et al. 2002) and immobilization (Mateo et al. 2007; Bhandari et al. 2008) have been used to improve enzyme stabilities at high pH. In a previous study, we suggested that alkaline active enzymes having acidic surfaces as one way of stability at high pH may be surrounded

by a water shield that possibly protects the enzymes from the effects of high pH (Mamo et al. 2009). Ectoines are known stabilizers of proteins against several stress factors such as salinity, heat, freezing and desiccation (Lippert and Galinski 1992; Göller and Galinski 1999). Exclusion of ectoines from the protein surface is the mechanism that results in a preferential hydration of the protein and hence its stabilization (Galinski 1993; Street et al. 2006). The compatible solutes are believed to increase the surface tension of water that disfavors the increase in surface area of the protein and consequently results in a compact folding state. Hence, the native state of the protein is favored by preferential hydration that makes unfolding more unfavorable in the presence of these solutes (Ratnaparkhi and Varadarajan 2001). This mechanism of preferential hydration of proteins is expected to improve the enzyme stabilization against the effect of high pH by decreasing the conformational entropy of the unfolded state.

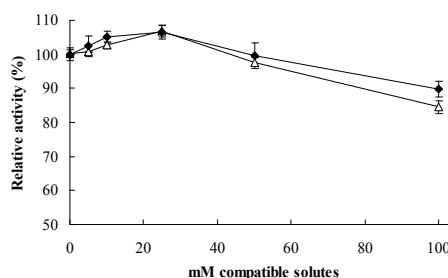

Fig. 5 Xylanase activity in the presence of varying concentrations of compatible solutes. The enzyme (2.2 µg/ml) was incubated at 70 °C with 1% (w/v) birchwood xylan dissolved in 50 mM glycine-NaOH buffer, pH 9 in the presence of varying ectoine (◆) and hydroxyectoine (Δ) concentrations

According to our earlier studies, the endoxylanase from *B. halodurans* has good stability in the pH range of 5.5-10.5 at 50 °C

Table 1. Effect of ectoine and hydroxyectoine on thermal stability of *B. halodurans* S7 xylanase at pH 9 and 10. The enzyme concentration used for the calorimetric experiments was 13.5 μ M in glycine-NaOH buffers (pH 9 and 10)

pH	xylanase		xylanase + ectoine		xylanase + hydroxyectoine	
	T_m (°C)	ΔH_{cal} (kcal/mol)	T_m (°C)	ΔH_{cal} (kcal/mol)	T_m (°C)	ΔH_{cal} (kcal/mol)
9	76.5	258.4	77.0	287.2	77.2	599.3
10	71.6	215.4	72.1	320.0	72.5	434.2

(Mamo et al. 2006). The enzyme is optimally active at pH 9 and 70 °C, and although the xylanase has some activity even at pH 12, its stability decreases sharply above 50 °C (Mamo et al. 2006). Ectoine and hydroxyectoine provided significant protection to the enzyme at low- as well as high pH (Fig. 1). Although they are closely related in structure (differing by a hydroxyl group), *in vitro* studies have shown that hydroxyectoine often has superior protein-stabilizing properties than ectoine and other compatible solutes (Lippert and Galinski 1992; Knapp et al. 1999; Borges et al. 2002), and the results in this study support these observations. Even *in vivo*, organisms tend to produce more hydroxyectoine than ectoine when the stress condition is more severe (Guzman et al. 2009), which may be due to its better protection efficiency than ectoine. How the hydroxyl group of hydroxyectoine makes it an efficient protein stabilizer remains to be elucidated. Trehalose is known to be an excellent protein stabilizer as compared to other disaccharides, polyols, proline and betaine (Borges et al. 2002). In this study, the ectoines were found to provide a better stabilizing effect than trehalose.

A very significant increase in melting temperatures of proteins in the presence of high concentrations of different compatible solutes has been reported (Santoro et al. 1992). However, melting temperatures of the xylanase

in this study were determined at a much lower concentration of ectoines (200 mM) and hence the change in the melting temperatures was not high (Table 1). On the other hand, more than two-fold increase in the calorimetric enthalpy (ΔH_{cal}) was achieved in the presence of hydroxyectoine. A similar observation is made for an α -amylase by D'Amico et al. (2001) who discussed that the increase in calorimetric enthalpy is due to the stabilizing effect of the additive. The stabilizing effect of hydroxyectoine is enthalpic in nature (Knapp et al. 1999), which is also clearly demonstrated for the xylanase at high pH.

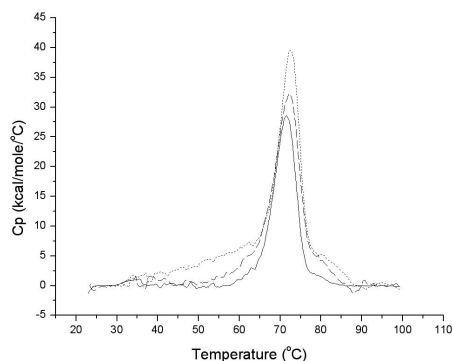

Fig. 6 Differential scanning calorimetry thermograms of *B. halodurans* xylanase with and without ectoines at pH 10. The graphs show the thermal unfolding behavior of the xylanase (solid), and of the enzyme in the presence of 200 mM ectoine (dashed) or hydroxyectoine (dotted)

There is a general notion that compatible solutes do not affect the physiology of organisms even at Molar concentrations, nevertheless the presence of these compounds above certain concentrations is known to decrease the activity of enzymes (Schnoor et al. 2004; Kolp et al. 2006; Kurz 2008). The activity of the *B. halodurans* xylanase was lowered in the presence of even 100 mM ectoines (Fig. 5). It seems the effect of compatible solutes on the activity of enzymes is not universal and varies with the enzyme and nature of the solute.

How do compatible solutes decrease the activity of enzymes? So far, few possible hypotheses have been forwarded for explaining this. The inhibition of DNA polymerase activity at high concentrations of compatible solutes has been attributed to their effect on primer annealing and on the formation of synthesis complex containing DNA, oligonucleotide and polymerase (Schnoor et al. 2004). There have also been reports on low water activity caused by compatible solutes that drastically reduce the dissociation of the *EcoRI* DNA complex and concomitantly impair the endonuclease activity (Kurz 2008). Although the mechanism may vary from protein to protein and solute to solute, molecular crowding in the vicinity of protein surfaces (especially around the catalytic sites) may to some extent hinder the binding between substrate and enzyme. Enzymes are evolved to be flexible to some degree, which is important for their activity but also makes them sensitive to environmental changes. However, the presence of compatible solutes may reduce enzymes' conformational flexibility and hence its catalytic efficiency while increasing stability.

Acknowledgement

The authors would like to thank the Swedish International Development Cooperation Agency (Sida) for supporting this work.

References

- Anderson, M.M., Breccia, J.D., Hatti-Kaul, R., 2000. Stabilizing effect of chemical additives against oxidation of lactate dehydrogenase. *Biotechnol. Appl. Biochem.* 32: 145-153
- Bhandari, S., Gupta, V. K., Singh, H., 2008. Enhanced stabilization of mungbean thiol protease immobilized on glutaraldehyde-activated chitosan beads. *Biocatal. Biotransform.* 27: 71-77
- Borges, N., Ramos, A., Raven, N.D.H., Sharp, R.J., Santos, H., 2002. Comparative study of the thermostabilizing properties of mannosylglycerate and other compatible solutes on model enzymes. *Extremophiles* 6: 209-216
- Bursy, J., Kuhlmann, A.U., Pittelkow, M., Hartmann, H., Jebbar, M., Pierik, A.J., Bremer, E., 2008. Synthesis and uptake of the compatible solutes ectoine and 5-hydroxyectoine by *Streptomyces coelicolor* A3(2) in response to salt and heat stress. *Appl. Environ. Microbiol.* 74: 7286-7296
- Empadinhas, N., da Costa, M.S., 2006. Diversity and biosynthesis of compatible solutes in hyper/thermophiles. *Int. Microbiol.* 9: 199-206
- Galinski, E.A., 1993. Compatible solutes of halophilic eubacteria: molecular principles, water-solute interaction, stress protection. *Experientia* 49: 487-496
- Guzmán, H., Van-Thuoc, D., Martín, J., Hatti-Kaul, R., Quillaguamán, J., 2009. A process for the production of ectoine and poly(3-hydroxybutyrate) by *Halomonas boliviensis*. *Appl. Microbiol. Biotechnol.* 84: 1069–1077

- Göller, K., Galinski, E.A., 1999. Protection of a model enzyme (lactate dehydrogenase) against heat, urea and freeze-thaw treatment by compatible solute additives. *J. Mol. Catal. B: Enzym.* 7: 37-45
- Horikoshi, K., 1999. Alkaliphiles: Some applications of their products for biotechnology. *Microbiol. Mol. Biol. Rev.* 63: 735-750.
- Kempf, B., E. Bremer., 1998. Uptake and synthesis of compatible solutes as microbial stress responses to high osmolality environments. *Arch. Microbiol.* 170: 319-330.
- Kolp, S., Pietsch, M., Galinski, E.A., Gütschow, M., 2006. Compatible solutes as protectants for zymogens against proteolysis. *Biochim. Biophys. Acta.* 1764: 1234-1242
- Kuhlmann, A.U., Bursy, J., Gimpel, S., Hoffmann, T., Bremer., 2008. Synthesis of the compatible solute ectoine in *Virgibacillus pantothenicus* is triggered by high salinity and low growth temperature. *Appl. Environ. Microbiol.* 74: 4560-4563
- Kulkarni, N., Shendye, A., Rao, M., 1999. Molecular and biotechnological aspects of xylanases. *FEMS Microbiol. Rev.* 23: 411-456
- Lentzen, G., Schwarz, T., 2006. Extremolytes: natural compounds from extremophiles for versatile applications. *Appl. Microbiol. Biotechnol.* 72: 623-634.
- Lippert, K., Galinski, E.A., 1992. Enzyme stabilization by ectoine-type compatible solutes: protection against heating, freezing and drying. *Appl. Microbiol. Biotechnol.* 37: 61-65.
- Louis, P., Trüper, H.G., Galinski, E.A., 1994. Survival of *Escherichia coli* during drying and storage in the presence of compatible solutes. *Appl. Microbiol. Biotechnol.* 41: 684-688.
- Mamo, G., Delgado, O., Martinez, A., Hatti-Kaul, R., Mattiasson, B., 2006. Cloning, sequence analysis and expression of a gene encoding an endoxylanase from *Bacillus halodurans* S7. *Mol. Biotechnol.* 33: 149-160.
- Mamo, G., Thunnissen, M., Hatti-Kaul, R., Mattiasson, B. 2009. An alkaline active xylanase: insights into mechanisms of high pH catalytic adaptation. *Biochimie* 91: 1187-96
- Mateo, C., Grazú, V., Pessela, B.C.C., Montes, T., Palomo, J.M., Torres, R. Lopez-Gallego, F., Fernandez-Lafuente, R., Guisa, J.M. 2007. Advances in the design of new epoxy supports for enzyme immobilization-stabilization. *Biochem. Soc. Trans.* 35: 1593-1601.
- Miller, G.R., 1959. Use of dinitrosalicylic acid reagent for determination of reducing sugar. *Anal. Chem.* 31: 426-428.
- Oren, A., 1999. Bioenergetic aspects of halophilism. *Microbiol. Mol. Biol. Rev.* 63: 334-348
- Oren, A., 2002. Unexpected diversity of heterotrophic prokaryotes living at highest salt concentrations. *Proceedings of the First European Workshop on Exo-Astrobiology*, 16 - 19 September, Graz, Austria
- Oren, A., 2006. Life at high salt concentrations. In: Dworkin M., Falkow S., Rosenberg E., Schleifer K-H., Stackebrandt E. (eds), *The Prokaryotes. A Handbook on the Biology of Bacteria: Ecophysiology and Biochemistry.* Springer, New York, 2: 263-282.
- Oren, A., 2008. Microbial life at high salt concentrations: phylogenetic and metabolic diversity. *Saline Systems (On-line Journal)*. 4:2 DOI: 10.1186/1746-1448-4-2.
- Poolman, B., Glaasker, E., 1998. Regulation of compatible solute accumulation in bacteria. *Mol. Microbiol.* 29: 397-407.

- Ratnaparkhi, G.S., Varadarajan, R., 2001. Osmolytes stabilize ribonuclease S by stabilizing its fragments S protein and S peptide to compact folding-competent states. *J. Biol. Chem.* 276: 28789-28798.
- Roberts, M.F., 2005. Organic compatible solutes of halotolerant and halophilic microorganism. *Saline Systems*. 1:5 DOI: 10.1186/1746-1448-1-5.
- Santoro, M.M., Liu, Y., Khan, S.M., Hou, L.X. and Bolen, D.W., 1992. Increased thermal stability of proteins in the presence of naturally occurring osmolytes. *Biochemistry* 31: 5278-5283.
- Street, T.M., Bolen, D.W., Rose, G.D., 2006. A molecular mechanism for osmolyte-induced protein stability. *PNAS* 103: 13997-14002.
- Welsh, D.T., 2000. Ecological significance of compatible solute accumulation by microorganisms: from single cells to global climate. *FEMS Microbiol. Rev.* 24: 263-290.