



LUND UNIVERSITY

Climate Change Effects on Rainfall and Management of Urban Flooding

Rana, Arun

2013

[Link to publication](#)

Citation for published version (APA):

Rana, A. (2013). *Climate Change Effects on Rainfall and Management of Urban Flooding*. [Doctoral Thesis (compilation), Division of Water Resources Engineering].

Total number of authors:

1

General rights

Unless other specific re-use rights are stated the following general rights apply:

Copyright and moral rights for the publications made accessible in the public portal are retained by the authors and/or other copyright owners and it is a condition of accessing publications that users recognise and abide by the legal requirements associated with these rights.

- Users may download and print one copy of any publication from the public portal for the purpose of private study or research.
- You may not further distribute the material or use it for any profit-making activity or commercial gain
- You may freely distribute the URL identifying the publication in the public portal

Read more about Creative commons licenses: <https://creativecommons.org/licenses/>

Take down policy

If you believe that this document breaches copyright please contact us providing details, and we will remove access to the work immediately and investigate your claim.

LUND UNIVERSITY

PO Box 117
221 00 Lund
+46 46-222 00 00

Climate change effects on rainfall and management of urban flooding

by

Arun Rana



LUND
UNIVERSITY

Akademisk avhandling för avläggande av teknologie doktorsexamen vid tekniska fakulteten vid Lunds Universitet kommer att offentligens försvaras vid Institutionen för Bygg- och Miljöteknologi, John Ericssons väg 1, Lund, hörsal V:C, fredagen den 27 september 2013, kl. 10:15.

Academic thesis submitted to Lund University in partial fulfilment of the requirements for the degree of Doctor of Philosophy (Ph.D. Engineering) and will be publically defended at the Department of Building and Environmental Technology, John Ericssons väg 1, lecture hall V:C Friday, September 27, 2013, at 10:15 a.m.

Fakultetsopponent/Faculty opponent: Dr Karsten Arnbjerg-Nielsen, Urban Water Engineering (UWE) - DTU Environment, Department of Environmental Engineering, Technical University of Denmark.

Organisation LUND UNIVERSITY Water Resources Engineering Box 118 SE-221 00 LUND Sweden	Document name Doctoral thesis
	Date of issue September 27, 2013
	Coden: LUTVDG/TVVR-1060 (2013)
Author: Arun Rana	
Title and subtitle: Climate change effects on rainfall and management of urban flooding	
Abstract Flooding in urban basins is intensifying due to increasing urbanization and climate change and variability. This thesis presents how the effects of climate change and high-intensive rainfall on the urban drainage system and management of flooding in urban areas of were studied in Mumbai, India and Southern Sweden, including Skåne and Gothenburg. Various statistical and analytical tools were applied to study trends and extreme events in two study areas. The impact of climate change on Mumbai was studied using nine GCM simulations with bias correction using DBS methodology. For Gothenburg, RCM output and observations were used to predict the characteristics of rainfall. Through use of transient DBS processed projection data, an impact analysis (climate and extreme value statistics) was performed for the future period of the years 2010 to 2099. Trend analysis using the student t-test and the Mann-Kendall test was also performed. Further, Random Cascade modelling was applied on daily rainfall data to reproduce high temporal resolution data for Mumbai. The method can be used for development of IDF curves. The generated data were used for flood modelling in the area and the generation of flood maps. Trends for monthly, seasonal, and annual precipitation were studied for Mumbai (1951-2004). For Southern Sweden, daily and multi-day precipitation trends were studied. Long-term precipitation trends were determined using the Mann-Kendall test, the student t-test, and linear regression. The trends for rainfall in Mumbai were corroborated with climatic indices using multivariate statistical tools, namely PCA and SVD. PCA was also used for explaining variability in RCM-generated precipitation in Gothenburg. Analytical analyses were made of the drainage systems in Mumbai and Gothenburg. Finally, an integrated two-dimensional (2D) hydrodynamic runoff model was used to simulate storm-water flooding and related processes in the metropolitan areas of Mumbai, India. The analysis revealed a high degree of variability in rainfall over Mumbai. A significant decreasing trend for long-term southwest monsoon rainfall was found. Also, a decrease in average maximum daily rainfall was indicated. The southwest monsoon rainfall over Mumbai was found to be inversely related to the Indian Ocean dipole, the El Niño-Southern Oscillation, and the East Atlantic Pattern. In Southern Sweden, however, annual precipitation has increased significantly due to increasing winter precipitation. There is an increasing trend for maximum annual daily precipitation at one location where the annual maximum often occurs in winter. The number of events with short return periods is increasing, but the number of other extreme events has not increased. Evaluation of the baseline period using the DBS bias correction method showed that observed and scaled rainfall data are strongly correlated and that these can represent various key statistics including mean, variance, and extreme values. The analysis of future long-term climate projections revealed a positive significant trend for 4 out of 9 model simulations for daily extreme rainfall during the period 2010-2099. In the case of Gothenburg, the results obtained pointed towards the usefulness of high resolution RCMs for impact studies. In random cascade modelling, very good agreement between modelled and observed disaggregation rainfall series was found for time scales larger than 1/2 h when short-term data were available. Established IDF-curves showed that the current design standard for Mumbai City has a return period of less than one year. Thus, annual recurring flooding problems in Mumbai appear evident. This was further emphasized in results from flood modelling and analytical studies.	
Key words: Climate Change, Extreme Events, Intensive Rainfall, Urban Drainage, Intensity-Duration-Frequency, Statistical analysis, Flood Management	
Classification system and/or index terms (if any)	
Supplementary bibliographic information	Language: English
ISSN and key title: 1101-9824	ISBN: 978-91-7473-636-6
Recipient notes	Number of pages: 216 Price:
	Security classification:

Distribution by the Division of Water Resources Engineering, Lund University, Box 118, 221 00 Lund, Sweden

I, the undersigned, being the copyright owner of the abstract of the above-mentioned thesis, hereby grant to all reference sources permission to publish and disseminate the abstract of the above-mentioned thesis.

Signature 

Date 2013-08-16

WATER RESOURCES ENGINEERING
DEPARTMENT OF BUILDING AND ENVIRONMENTAL TECHNOLOGY
FACULTY OF ENGINEERING, LUND UNIVERSITY
CODEN: LUTVDG/TVVR-1060 (2013)

Doctoral Thesis

Climate change effects on rainfall and management of urban flooding

by

Arun Rana



LUND
UNIVERSITY

September 2013

Climate change effects on rainfall and management of urban flooding

© Arun Rana, 2013, unless otherwise stated

Doktorsavhandling
Teknisk Vattenresurslära
Institutionen för Bygg- och Miljöteknologi
Tekniska Fakultetet
Lunds Universitet

Doctoral Thesis
Water Resources Engineering
Department of Building & Environmental Technology
Faculty of Engineering
Lund University

Box 118
221 00 LUND
Sweden

<http://www.tvrl.lth.se>

Cover: A picture of lake with thunder clouds in India (left) and Sunset over a storm water collection pond in Southern Sweden (right). Photo Credits: Arun Rana

CODEN: LUTVDG/ (TVVR-1060) (2013)

ISBN: 978-91-7473-636-6

ISSN: 1101-9824

Report 1060

Printed in Sweden by Media-Tryck, Lund 2013



ACKNOWLEDGEMENTS

I would first of all like to thank my supervisor, Prof. Lars Bengtsson, for convincing me to become involved in the exciting field of extreme events and climate change, for helping me to build a professional network, and for always encouraging me. I also wish to thank my co-supervisors, Prof. Ronny Berndtsson and Prof. Arun Kansal. I am also thankful to Prof. Cintia Bertacchi Uvo for her constant support and advice all throughout the work.

I want to thank my fellow present and former doctoral students and colleagues at the Department of Water Resources Engineering (TVRL). Especially I would like to mention Prof. Rolf Larsson, Prof. Kenneth M Persson, Dr. Hanna Modin, Dr. Raed Bashitialshaer, Dr. Mohammad Aljaradin, Feifei Yuan, Lena Flyborg, Kean Foster, Hossein Hashemi, Angelica Liden, Shuang Liu, Fabio Pareira, Johanna Sorensen, Rodrigo Villegas, and Sofia Westergren. I want to express my appreciation to all of you who have co-authored papers with me as well as to those who proofread (parts of) this thesis and supplied many valuable comments.

My research was funded by the Erasmus-Mundus scholarship from European Union for 36 months and further by FORMAS and Svenskt Vatten Utveckling/Swedish Water Research and Development Project. This support is gratefully acknowledged. Scholarship awards for various activities from Ångpanneföreningens Forskningsstiftelse Foundation, Hörjels (Stiftelsen Landshövding Nils HörjelsForskningnsfond vid Lunds Tekniska Högskola), Stiftelsen Margit Stiernswärds Fond för Miljövårdsforskning, and Stiftelsen Lars Hiertas Minne are also highly acknowledged.

The support from my parents, Kamlesh and Vijay Rana, has been invaluable. It is fantastic to feel that, no matter what, you are always on my side. I also want to send my love to my grandmother Chandrika who took such a proud interest in my studies. Last but not least I would like to acknowledge the support from my brother, sister, and friends back home and in Sweden.

POPULÄRVETENSKAPLIG SAMMANFATTNING

Översvämningar i städer ökar på grund av ökad urbanisering samt klimatförändringar och klimatvariabilitet. Denna avhandling presenterar effekterna av klimatförändringar och intensiv nederbörd i städer samt handhavandet av översvämning i urbana områden i Mumbai, Indien och i Skåne samt Göteborg. En rad statistiska och analytiska verktyg har tillämpats för att studera nederbördstrender och extrema nederbördshändelser i två områden. I Mumbai har effekten av klimatförändringar studerats med hjälp av nio GCM-simuleringar (General Circulation Model) med bias-korrektur genom distributionsbaserad skalering (DBS) och för Göteborg har GCM-utdata och observationer använts för att karakterisera nederbörd. Genom att använda en DBS-processad projektion av högupplöst data har en konsekvensanalys (klimat- och extremvärdesstatistik) genomförts för den framtida perioden 2010–2099. Det har också gjorts en trendanalys med Students t-test och Mann-Kendall-testet. Vidare har Random Cascade-modellering tillämpats på nederbördsdata för att skapa högupplöst data för Mumbai. Metoden kan användas för att utarbeta IDF-kurvor. Samma skapade data har använts i översvämningssmodellering och på så vis har översvämningsskartor utarbetats. Nederbördstrender för månad, säsong och år har studerats för Mumbai (1951–2004). För Skåne och Göteborg har trender för dygns- och flerdygnsnederbörd studerats. Långsiktiga trender har framställts med Mann-Kendall-testet, Students t-test och linjär regression. Nederbördstrenderna för Mumbai har kunnat styrkas med klimatindicer genom multivariabla, statistiska verktyg: PCA och SVD. PCA har även använts för att beskriva variation i RCM-genererad nederbörd i Göteborg. Dagvattensystemet i Mumbai respektive Göteborg har analyserats analytiskt. Slutligen har en integrerad tvådimensionell (2D) hydrodynamisk avrinningsmodell använts för att simulera översvämning från dagvatten i de metropolitiska områdena av Mumbai, Indien. Resultaten visar på stor variation i nederbörd i Mumbai. Det ses en signifikant, nedåtgående trend för långsiktiga, sydvästliga monsunregn. Dessutom ses en minskad genomsnittlig, maximal dygnsnederbörd. Det ses att sydvästliga monsunregn i Mumbai är negativt korrelerade med Indiska oceanens dipol, El Niño–sydlig oscillation och East Atlantic Pattern. I Skåne och Göteborg har däremot den årliga nederbörden ökat signifikant på grund av ökande nederbördsmängder om vintern. Det ses en ökning av årshögsta dygnsnederbörden på en plats, där har det högsta värdet ofta uppmätts om vintern. Antalet kraftiga nederbördshändelser med korta återkomstperioder har ökat, men antalet av de extrema händelserna har inte ökat. Utvärderingen av jämförelseperioden med hjälp av DBS-biaskorrektur visade att mätt och skalerad nederbördsdata är starkt korrelerade och att skalerad data kan användas för att representera olika statistiska värden såsom medel, varians och extremvärden. Analysen av framtida långsiktiga klimatförutsägelser visar en signifikant, positiv trend för fyra av de nio modeller som använts för att studera extrem dygnsnederbörd för perioden 2010–2099. När det gäller Göteborg pekar resultaten på att högupplösta RCM-modeller kan användas för studier av klimatpåverkan. För en halvårsperiod kunde det konstateras en mycket god överensstämmelse mellan modellerade och observerade tidsserier vid Random Cascade-modellering för tidsperioder som var längre än en halvtimme när högupplöst data fanns att tillgå. IDF-kurvorna som utarbetats visade att den gällande dimensioneringsstandarden för Mumbai har en

återkomstperiod på under ett år. Därmed står det klart att årliga översvämningsproblem i Mumbai är att förvänta. Detta understryks av resultaten från översvämningsmodelleringen och de analytiska studierna.

ABSTRACT

Flooding in urban basins is intensifying due to increasing urbanization and climate change and variability. This thesis presents how the effects of climate change and high-intensive rainfall on the urban drainage system and management of flooding in urban areas were studied in Mumbai, India and Southern Sweden, including Skåne and Gothenburg. Various statistical and analytical tools were applied to study trends and extreme events in two study areas. The impact of climate change on Mumbai was studied using nine GCM simulations with bias correction using DBS methodology. For Gothenburg, RCM output and observations were used to predict the characteristics of rainfall. Through use of transient DBS processed projection data, an impact analysis (climate and extreme value statistics) was performed for the future period of the years 2010 to 2099. Trend analysis using the student t-test and the Mann-Kendall test was also performed. Further, Random Cascade modelling was applied on daily rainfall data to reproduce high temporal resolution data for Mumbai. The method can be used for development of IDF curves. The generated data were used for flood modelling in the area and the generation of flood maps. Trends for monthly, seasonal, and annual precipitation were studied for Mumbai (1951-2004). For Southern Sweden, daily and multi-day precipitation trends were studied. Long-term precipitation trends were determined using the Mann-Kendall test, the student t-test, and linear regression. The trends for rainfall in Mumbai were corroborated with climatic indices using multivariate statistical tools, namely PCA and SVD. PCA was also used for explaining variability in RCM-generated precipitation in Gothenburg. Analytical analyses were made of the drainage systems in Mumbai and Gothenburg. Finally, an integrated two-dimensional (2D) hydrodynamic runoff model was used to simulate storm-water flooding and related processes in the metropolitan areas of Mumbai, India. The analysis revealed a high degree of variability in rainfall over Mumbai. A significant decreasing trend for long-term southwest monsoon rainfall was found. Also, a decrease in average maximum daily rainfall was indicated. The southwest monsoon rainfall over Mumbai was found to be inversely related to the Indian Ocean dipole, the El Niño-Southern Oscillation, and the East Atlantic Pattern. In Southern Sweden, however, annual precipitation has increased significantly due to increasing winter precipitation. There is an increasing trend for maximum annual daily precipitation at one location where the annual maximum often occurs in winter. The number of events with short return periods is increasing, but the number of other extreme events has not increased. Evaluation of the baseline period using the DBS bias correction method showed that observed and scaled rainfall data are strongly correlated and that these can represent various key statistics including mean, variance, and extreme values. The analysis of future long-term climate projections revealed a positive significant trend for 4 out of 9 model simulations for daily extreme rainfall during the period 2010-2099. In the case of Gothenburg, the results obtained pointed towards the usefulness of high resolution RCMs for impact studies. In random cascade modelling, very good agreement between modelled and observed disaggregation rainfall series was found for time scales larger than 1/2 h when short-term data were available. Established IDF-curves showed that the current design standard for Mumbai City has a return period of less than one year. Thus, annual recurring

flooding problems in Mumbai appear evident. This was further emphasized in results from flood modelling and analytical studies.

PAPERS

Appended papers

This thesis is based on the following papers, which will be referred to in the text by their Roman numerals. The papers are appended at the end of the thesis.

- I. **Rana, A.** (2011) Avoiding natural disaster in megacities – Case study for urban drainage of Mumbai. *Vatten* 67:55–59.
- II. **Rana, A., Uvo, C. Bengtsson, L. and Sarthi P.P.** (2012) Trend analysis of rainfall for Delhi and Mumbai, India. *Climate Dynamics* 38 (1):45-56. Doi: 10.1007/s00382-011-1083-4.
- III. Bengtsson, L. and **Rana, A.** (2013) Long-term change of daily and multi-daily precipitation in southern Sweden. *Hydrological Processes*. DOI: 10.1002/hyp.9774
- IV. **Rana, A., Foster, K., Bosshard, T., Olsson, J. and Bengtsson, L.** (2013) Impact of climate change on rainfall over Mumbai using Distribution Based Scaling (DBS) of Global Climate Model (GCM) projections. (Manuscript)
- V. **Rana, A., Madan, S. and Bengtsson, L.** (2012) Performance evaluation of Regional Climate Models (RCMs) in determining precipitation characteristics for Göteborg, Sweden. *Hydrology Research*. doi:10.2166/nh.2013.160
- VI. **Rana, A., Bengtsson, L., Olsson, J. and Jothiprakash, V.** (2013) Development of IDF-Curves for Tropical India by Random Cascade Modeling. *Hydrol. Earth Syst. Sci. Discuss.*, 10, 4709–4738, doi:10.5194/hessd-10-4709-2013
- VII. Sörensen, J. and **Rana, A.** (2013) Comparative analysis of flooding in Gothenburg, Sweden and Mumbai, India: A review, CORFU, International Conference on Flood Resilience: Experiences in Asia and Europe, 5-7 September 2013, Exeter, United Kingdom.
- VIII. **Rana, A., Henonin, J., Bengtsson, L., and Mark, O.** (2013) An integrated modeling approach - Urban flooding inundation in Mumbai, CORFU, International Conference on Flood Resilience: Experiences in Asia and Europe, 5-7 September 2013, Exeter, United Kingdom.

Author's contributions to the appended papers

- I. The author planned the work, prepared and analysed the results, and wrote the paper.
- II. The author planned the study together with the co-authors, performed statistical analysis work, analysed the data together with the co-authors, and wrote the paper assisted by the co-authors.

- III. The author performed the work of data compilation from books not available in digital format, planned the statistical analysis with the co-authors, and analysed the results together with the co-authors.
- IV. The author planned the study together with the co-authors, performed analysis of data with co-authors, analysed the data together with the co-authors, and wrote the paper assisted by the co-authors.
- V. The author planned the statistical analysis together with the co-authors, performed the statistical analysis, analysed the results together with the co-authors, and wrote the paper together with the co-authors.
- VI. The author planned the study together with the co-authors, performed the experimental work, interpreted the results together with the co-authors, and wrote the paper assisted by the co-authors.
- VII. The author planned the study together with the co-authors, performed the experimental work, interpreted the results together with the co-authors, and wrote the parts of paper associated with Mumbai along with the co-authors.
- VIII. The author planned the study together with the co-authors, performed the experimental work, interpreted the results together with the co-authors, and wrote the paper assisted by the co-authors.

Related publications not included in this thesis

Journals and Magazines

Singh, W. and **Rana, A.** (2012) Mapping and situation analysis of drinking water resources in India – A participatory approach. *Vatten - Journal of water management and research*, 68: 75-83.

Filipova, V., **Rana, A.** and Singh, P. (2012) Urban Flooding in Gothenburg - A MIKE 21 Study. *Vatten - Journal of water management and research*, 68: 175-184.

Conference papers

Rana, A. and Sinha, V. (2009) Wind Energy Estimation using Geoinformatics and SDSS for Feasibility Study. International Digital Governance and Hotspot Geoinformatics conference, June 1-3, 2009, TERI University, Delhi, India

Rana, A., Bengtsson, L., Jyothiprakash, and Singh, W. (2010) Rainfall and climatic scenarios for design of drainage system. Proc. XXVI Nordic Hydrological Conference, Aug 2010, Riga, Latvia

Rana, A., Madan, S. and Bengtsson, L. (2012) On Climate Prediction: Performance Evaluation of Regional Climate Models (RCMs). Proc. XXVII Nordic Hydrological Conference, Aug 2012, Oulu, Finland

Master theses supervised by the author

Filipova, V., 2012. Urban Flooding in Gothenburg - A MIKE 21 Study. Water Resources Engineering. Lund University, Lund, Sweden.

Madan, S., 2012. On Climate Prediction: Performance Evaluation of Regional Climate Models (RCMs), Department of Mathematical Statistics and Department of Water Resources Engineering, Lund University, Lund, Sweden. (In Swedish)

ABBREVIATIONS AND SYMBOLS

CDF	Cumulative Distribution Function
CV	Coefficient of Variation
DBS	Distribution Based Scaling
EA	East Atlantic
EA/WR	East Atlantic/West Russia
EP/NP	East Pacific/North Pacific
GEV	Generalised Extreme Value Distribution
IDF	Intensity-Duration-Frequency
IOD	Indian Ocean Dipole
IMD	Indian Meteorological Department
GCMs	Global Climate Models
MCGM	Municipal Corporation of Greater Mumbai
MOHC	Met Office Hadley Centre
NAO	North Atlantic Oscillations
NINO _{3,4}	El Nino- Southern-Oscillation
NOAA	National Weather Service, Climate Prediction Centre
PCA	Principal Component Analysis
PDO	Pacific Decadal Oscillations
PNA	Pacific/North American Oscillations
RC	Relative Change (%)
RCMs	Regional Climate Models
SD	Standard Deviation
SMHI	Swedish Meteorological and Hydrological Institute
SVD	Singular Value Decomposition
SWOT	Strength Weakness Opportunity and Threats analysis
SCA	Scandinavian Oscillations
T ₅₀	50 Year Return Period
T ₁₀₀	100 Year Return Period
WHO	World Health Organisation
WP	West Pacific

CONTENTS

1	Introduction	1
1.1	Background	1
1.2	Objective and scope	2
1.3	Thesis structure and appended papers	3
2	Review of Literature and Existing Knowledge within the field	7
2.1	Climate Change and its impact studies	7
2.2	GCM and RCMs for Impact studies	7
2.3	Trends, Extremes and Climate relations	8
2.4	Need for high resolution temporal data	10
2.5	Urban Flooding and its modelling	11
3	Study area, Data and methodology	13
3.1	Study Area	13
3.1.1	Mumbai, India	13
3.1.2	Southern Sweden and Gothenburg	14
3.2	Data Sets	14
3.3	Linear and Non Linear Data Analysis	15
3.3.1	Univariate and Multivariate statistical Analysis	15
3.3.2	Extreme events/Trend Analysis	16
3.4	Climate change analysis	17
3.4.1	Bias correction	17
3.4.2	Impact Analysis	17
3.5	Random Cascade modelling, disaggregation and IDF development	18
3.5.1	Disaggregation and cascade modelling	18
3.5.2	IDF development	19
3.6	Situation analysis	19
3.7	Flood modelling and analysis	20
4	Results	21
4.1	Linear and Non Linear Data Analysis	21
4.1.1	Univariate and Multivariate statistical Analysis	21
4.1.2	Extreme events/trend analysis	23
4.2	Climate change Analysis	26
4.2.1	Bias Correction	26
4.2.2	Impact Analysis	28
4.3	Random Cascade modelling, disaggregation and IDF development	29
4.3.1	Disaggregation and cascade modelling	29

4.3.2	IDF development	30
4.4	Situation analysis	32
4.5	Flood modelling and analysis	33
5	Discussion and concluding remarks	35
5.1	Mumbai, India	35
5.2	Southern Sweden and Gothenburg	36
5.3	Disaggregation of Rainfall	37
5.4	Outlook and Future Work	37
6	References	39
Appended papers		

1 INTRODUCTION

1.1 Background

Floods are among the most powerful forces on earth, causing enormous damage all over the world. During the last decade, floods have killed about 100,000 people and affected over 1.4 billion (OFDA/CRED, 2013). Statistics show that floods have a large impact on human well-being and economy. Economic damage, eco-system damage, and loss of historical and cultural values constitute direct consequences of flood. They lead to the loss of human life and cause negative human health effects (Hajat et al., 2005; WHO, 2002). Floods indirectly cause the loss of economic and agricultural production and decreases in socio-economic welfare (Appleton, 2002). Studies focusing on floods and their impact include, among others, Coates (1999) on the situation in Australia, and Mooney (1983) and French (1983) on the United States. Although every flood can be considered a unique event with unique characteristics, patterns may be observed when a large number of floods are studied, e.g., floods from rivers, precipitation, and tides.

From an urban area perspective, the prevention of flooding may be associated with adequate sewer systems. With increased property values of buildings and other structures, the potential damage from prolonged flooding can easily extend into millions of dollars. However, drainage systems designed to cope with the most extreme storms are too expensive to build and operate. In establishing tolerable flood frequencies, the safety of the residents and the protection of their property must be in balance with technical and economic restrictions. Knowledge of social systems and their vulnerabilities remain weak, even though the social system is a key element of the social response to flood and of urban dynamics more generally (Hall et al., 2003). The response of the drainage system to rain events in the urban environment is characterized by two main components: surface runoff on natural slopes and artificial drainage system including levelling of constructions in the city. In most cities, the artificial drainage system is controlled by a combined sewer network, which collects and sends both storm-water and wastewater to the treatment plant.

Urban areas are flooded by intense rain within the city, flooding from rivers or high sea levels, or failure of the drainage system itself. However, within the urban context, heavy and short-term rainfall produces the most relevant flooding. The distribution of rainfall in both space and time is, however, extremely variable. An increase in the intensity and/or frequency of extreme rainfall events may result in flooding of urban areas (Ashley et al., 2005; Mailhot et al., 2007).

Many researchers have described the possible impacts of climate change on urban drainage infrastructure and analysed the specific impacts on various urban areas, e.g., (Denault et al., 2006; Grum et al., 2006; Guo, 2006a; Guo, 2006b; Mailhot et al., 2007; Niemczynowicz, 1989; Niemczynowicz, 1999; Watt, 2003). Since flooding produced by storm-water is one of the most severe and frequent natural disasters in the world, the study of flood mitigation is very important. Thus, flood prevention and mitigation have long been researched in both hydrology and hydraulics.

Many urban locations around the globe are becoming increasingly vulnerable to natural hazards related to weather and climate (De and Dandekar, 2001). Thus, the study of trends in precipitation and their physical explanations are increasingly important. These trends should then be corroborated with detailed studies to find variation over long periods keeping in mind future expected changes. Dore (2005) has highlighted broad implications for future global precipitation, and suggests that several regional precipitation trends can already be detected and are likely to increase in the future.

In western Europe, mainly the daily winter precipitation has changed leading to increased annual precipitation as shown in Sweden (Busuioc et al., 2011). For Britain, which has a climate similar to western Sweden, Maraun et al. (2008) have shown that while the winter rains have become more intense, the daily summer storms have decreased in intensity or show inter-decadal variability. Using 600 gauges within the Rhine Basin, Hundsdoerfer and Bárdossy (2005) concluded that the daily precipitation showed an increasing trend over 50 years in all seasons except summer, where it showed the opposite trend.

Assessment of extreme precipitation events is an important part of hydrologic risk analysis and design. Evaluation of rainfall extremes, as embodied in the intensity-duration-frequency (IDF) relationship, has long been a major focus of both theoretical and applied hydrology (Langousis and Veneziano, 2007). Rainfall frequency analyses are used extensively in the design of systems to handle storm water runoff, including roads, culverts and drainage systems.

Extreme weather events have had severe consequences for human societies since time immemorial. In the context of hydrology, the changing climate is likely to accelerate the hydrological cycle on a global scale, and subsequently intensify the uneven spatial and temporal distribution of hydrological resources (Huntington, 2006; Trenberth, 1999). The intensity of extreme precipitation is projected to increase under global warming in many parts of the world, even in the regions where mean precipitation decreases, e.g. (Semenov and Bengtsson, 2002; Wilby and Wigley, 2002). Climate change is expected to alter the intensity and frequency of extreme rainfalls (Frei et al., 1998; Frei et al., 2006; Kharin et al., 2007; McKibben, 2007). Thus, climate adaptation strategies for emergency planning, the design of engineering structures, reservoir management, pollution control, risk calculations, etc., rely on knowledge of the frequency of these extreme events (Kumke, 2001). Assessment of extreme precipitation events is also important for hydrological risk analysis and the design of infrastructure of cities. The increasing trend for precipitation extremes has quantifiable impacts on intensity duration frequency relations (Kao and Ganguly, 2011).

1.2 Objective and scope

The objective of the research described in this thesis was to investigate changes (past and future) in urban precipitation and its impact on flooding. Detailed analysis included the effects of climate change on intensive or extreme rainfall and urban drainage systems, and consequently the management of floods. This focus was chosen

since: (i) the climate is expected to change in the near future due to increases in greenhouse gases; (ii) extreme and intensive rainfall patterns and trends are changing either due to climatic variability or climate change, and, finally, (iii) the management of floods is extremely important in view of the above. The research focused on urban areas metropolitan areas in Mumbai, India, southern Sweden (Skåne), and Gothenburg, Sweden. A detailed long-term analysis of rainfall trends was carried out for both Mumbai and the larger southern region of Sweden. Climate change effects were studied in these areas using fine scale resolution RCM data for Gothenburg, and relatively low resolution GCM data for Mumbai (due to lack of RCM data for developing countries). Analytical studies including SWOT (Strength Weakness Opportunity and Threat) analysis were carried out to find the main problems leading to severe flooding situations in both the study areas, and finally solutions for improvement were suggested. Flood maps for Mumbai were generated for future reference.

Modelling tools were employed along with statistical methods for data analysis to address the following questions and goals:

- How have different large and extreme rainfall events changed in Mumbai and southern Sweden?
- How are different large and extreme rainfall events expected to change in the future?
- Find methods to disaggregate daily rainfalls into short-term rains.
- Determine probability of low frequency events.
- Estimate consequences of and basic factors behind urban flooding in Mumbai and Gothenburg.
- Compare rainfall and their consequences in India and Sweden.
- What are the analytical and technical solutions that could be implemented for prevention of flood and related disasters in the study areas?

1.3 Thesis structure and appended papers

This thesis is based on the research presented in the eight appended papers. After the introduction in Chapter 1, the theoretical background of the appended papers is presented in Chapter 2 together with references to recent research in the field. An overview of the methods and data sets used and the study areas are presented in Chapter 3. In Chapter 4 the main results from the appended papers together with findings are summarised, discussed, evaluated, and related to state of art in the field of study. Finally, in Chapter 5, conclusions, implications, unresolved questions, and suggestions for future research are presented.

The main methods used and results arrived at are included in this thesis but a more detailed account can be found in the appended papers, referred to by bold Roman numerals. Here follows a short description of the papers.

Mumbai was hit by an extreme rainfall event on 26 July 2005 leading to massive floods. The unprecedented rainfall of almost 1300 mm in 48 hours paralysed the economy of the country. In **Paper I**, the grim situation after the rainfall havoc is explained along with plausible causes. The present situation of the city's drainage

system is outlined along with a description of the major and minor drains (details can be found in the Study Area and Methodology section). The rain is related to the flood using IDF curves (later developed in **Paper VI**) with possible explanations for the deteriorating situation of large floods (**Paper VII** and **Paper VIII**). Finally, future work is outlined.

Paper II describes a study on trend analysis of rainfall during the period 1951-2004 in major cities of Delhi and Mumbai, India using the Mann-Kendall trend analysis test for the detection of any seasonal and annual trends. Further seasonal trends during monsoon season (June-September) at these stations were compared to global climatic indices (including SCA, EA/WR, WP, NAO, EP/NP, IOD, NINO 3.4, PDO, EA, and PNA) using PCA and SVD.

Paper III deals with analysis of daily rain series from southern Sweden with records dating back to the 1870s. It shows how trends of daily and multi-day precipitation of different return periods were investigated, and how probabilities of extreme storms were determined as continuously changing values based on 25 years of data. It shows how an extra set of data was used to investigate changes in Skåne, the southernmost area of Sweden. Another 30-year data set from a dense gauge network of more than 200 stations in Skåne was used to investigate the relation between very large daily rainfall and annual precipitation, which is also explained in this paper.

The study described in **Paper IV** emphasises the role of climate change and its impacts on urban infrastructure in Mumbai. Nine GCM were used in the study to investigate the plausible role of climate change in the future long-term precipitation received by the city. GCM data were first treated with DBS methodology as a statistical bias correction step and then the precipitation data were analysed in three different future scenarios, i.e., near (years 2010-40), intermediate (years 2040-70), and distant (years 2070-99). Use of the Distribution Based Scaling (DBS) method for GCM bias correction was also tested and presented in the paper. Long-term trends were investigated with the Mann-Kendall test, and 50-year return period (T₅₀) and 100 year return period (T₁₀₀) precipitation was also analysed in all the scenarios. The results were compared to findings from **Paper II**.

The Regional Climate Model (RCM) was used in predicting future climate scenarios on a small scale. In **Paper V**, analysis of such models for prediction of regional scale precipitation using five different RCMs was carried out. Various statistical methods were used to determine trends, extreme values and inter-annual variations. The analysis was performed on observed and gridded data from Gothenburg, Sweden.

High temporal resolution (10 min) rainfall data are usually not available in developing countries. In the study presented in **Paper VI**, IDF curves with duration down to 10 min were developed for the city of Mumbai using data from years 1951-2004. Using 6 months of rainfall series with high time resolution, a random cascade model was developed and applied in the tropical climate. Further extreme events were compared with results from **Paper II** and other related studies.

Paper VII presents a critical review of the flooding situations in Gothenburg, Sweden, and Mumbai, India (comparative analysis). Analytical tools and a literature review were used to describe the flooding situation in the two cities. The results for

Mumbai were corroborated with results presented in **Paper I**. Situation analysis and future perspectives for both cities were discussed.

Flood maps are handy tools in the decision-making process. **Paper VIII** makes an attempt to prepare detailed flood maps using MIKE 21 as a modelling tool for precipitation-based modelling in Mumbai. Modelling results were compared to earlier reports of flooding and previous findings. A flood hazard map was presented in the results with discussions on data limitations in the study area.

2 REVIEW OF LITERATURE AND EXISTING KNOWLEDGE WITHIN THE FIELD

This chapter provides a review of the existing literature and knowledge in the field. It provides a basis for the discussions on climate change, extreme events and urban flood management in the following chapters. It is not intended to present a full account of the field of study, but rather the necessary facts to familiarise the reader with the context in which the investigations were performed.

2.1 Climate Change and its impact studies

Climate change is caused by factors that include oceanic processes (such as oceanic circulation), biotic processes, variations in solar radiation received by the Earth, plate tectonics and volcanic eruptions, and human-induced alterations of the natural world. The latter effects are currently causing global warming, and the phrase "climate change" is often used to describe the human-specific impacts (Smithson, 2002; Thornes, 2002). There are many ways of estimating the impacts of climate change such as using projections of climate models, e.g., (Mailhot et al., 2007), analog studies, (Smith and Pitts, 1997), trend analyses, (Pagliara et al., 1998) or by assuming a relative increase of rainfall intensity in a future climate, i.e. sensitivity analysis, e.g., (Semadeni-Davies, 2004). Results of these studies vary substantially from one study to another, reflecting the variability of urban response to a change in extremes.

2.2 GCM and RCMs for Impact studies

Global Climate Models (GCMs) are currently the best way to model the complex processes that occur at the Earth system's level (i.e., for studying possible future changes in climate mean, variability, and extremes) (Huntingford et al., 2005). In most climate change studies, GCMs have been used to project future climatic variables. However, due to limitations in GCMs' powers to incorporate local topography (spatial and temporal), coarse horizontal resolution and inaccuracy of describing rainfall extremes due to a poor description of the non-stationary phenomenon during a convective storm, the direct use of their outputs in impact studies on catchment scale is also limited. There is often a clear bias in the statistics of variables produced by GCMs such as rainfall and temperature (Kay et al., 2006; Kotlarski, 2005).

Some of the earliest studies of the potential impacts of global warming in Europe were based on idealized GCM simulations. Some studies used results from only one model to illustrate potential impacts, e.g., (Emanuel et al., 1985) and some used a range of models for impact studies to ensure consistency e.g. (Parry, 1989). Later studies recognized inter-model uncertainties and adopted outputs from several GCMs, for example (Rotmans et al., 1994). The precipitation characteristics vary so much from region to region and locally within regions that the precipitation pattern can only be caught when the scale in the climate models is reduced. Jones et al. (1997) among

others, has pointed out the advantages of using RCM data over GCM data for small scale spatial studies. RCMs represent an advantage over GCM data for representing small scale processes as pointed out by Durman et al. (2001), because RCM simulations are more realistic when scaled, in comparison to GCM simulation data.

To bridge the gaps between the climate model scales and the local scales, and to account for the inaccuracies in describing rainfall extremes, downscaling methods and bias-correction methods are commonly used. Dynamic downscaling and statistical downscaling are the most commonly used methods (Bergstrom, 2001; Fowler et al., 2007; Pinto et al., 2010; Schoof et al., 2009; Wilby et al., 1999). Dynamic downscaling includes nesting of high resolution Regional Climate Models (RCMs) with that of GCMs which ensures consistency between climatological variables. However, they are computationally expensive. Statistical downscaling models, on the other hand, are based on statistical relationships between large-scale climate variables (predictors) and local-scale climate variables (predictant) and hence require less computational time. Extensive research has been carried out with both approaches, e.g., (Chen et al., 2012; Maraun et al., 2010; Teutschbein et al., 2011; Willems and Vrac, 2011).

2.3 Trends, Extremes and Climate relations

As a consequence of the atmospheric temperature increase, the water holding capacity of the atmosphere is also increasing, which ought to result in more intense short term storms, e.g., (Trenberth, 2011; Trenberth et al., 2003). With more humidity in the atmosphere, there may be a shift creating the large rains by convective mechanisms. Analyses of changes in climate extremes with coupled atmosphere–ocean general circulation models have been performed in many studies. These experiments indicate larger changes in extreme precipitation compared with changes in mean precipitation, e.g., (Kharin and Zwiers, 2000; Semenov and Bengtsson, 2002).

The annual precipitation in southern Sweden has increased over the last 100 years because of increased winter precipitation, e.g., (Dahlström, 2006). Investigating 75 series of 100 years' data from Europe, Moberg et al. (2006) found that the total winter precipitation has increased along with the large daily winter rains. There have been many studies of British daily precipitation records from 1961 to 1995 (e.g. (Osborn et al., 2000)). They all show that the winter rains have become more intense but that the daily summer storms have decreased in intensity. Maraun et al. (2008) updated the results to 2006. The prolonged time series shows that the trend of increased winter rain intensity has not continued at the rate reported for 1961–1995. For summer, the intensities turned back towards the 1961–1995 reference being more consistent with inter-decadal variability than with an overall trend. For the German part of the Rhine basin, Hundecha and Bárdossy (2005) investigated the daily extreme precipitation measured, and observed increasing trends in magnitude and frequency in all seasons except summer, where they observed the opposite trend. In Switzerland, the winter rains have been found to have increased (Schmidli and Frei, 2005). Here, no trend of changed high summer storms was reported. Moberg et al. (2006) analysed full 20th Century trends of rather moderate precipitation extremes calculated from daily observational data for 80 central and western European stations. Significant increasing precipitation trends dominate in winter for moderately strong events.

Madsen et al. (2009) analysed short-term storms in Denmark in the period 1980–2005 and observed that storms with durations of minutes and hours had increased over the period, especially the storms of long return periods. The daily storms had, however, not increased. For Canada, with a similar climate from that of Sweden, Zhang et al. (2001) investigated daily rainfalls with a return period of 20 years for the entire 20th Century but found no long-term trend. In Sweden, annual precipitation or summer precipitation are often used in combination with short-term rain intensities from other sites for determining design storms of moderate return periods (Dahlström, 1979). Madsen et al. (2009) derived intensity–frequency–duration curves for Denmark. The new study supported the previous findings that the regional variability of large rainfalls is partly explained by the annual precipitation. However, the very extreme events in southern Sweden seem to be randomly distributed spatially, with little relation to annual mean precipitation.

Climate projections for Sweden indicate higher temperatures, especially during winter. The Commission on Climate and Vulnerability was appointed by the Swedish Government in June 2005 to assess regional and local impacts of global climate change on Swedish society. In the study it was resolved that “Sweden will become warmer and wetter”—precipitation is likely to increase in most parts of the country during the autumn, winter, and springtime. In summertime the climate will be warmer and drier, particularly in southern Sweden. Large storms are expected to increase in the future climate. Thus, it is becoming increasingly important to study trends and extreme events in southern Sweden within changing climate scenarios. Although any significant increase of the extreme daily storms has not yet been observed in Western Europe, these model simulations indicate that the daily storms are expected to increase in the future, as also found for north-western Europe by Raisanen and Joelsson (2001).

Generally, the return periods of rains of certain intensities are expected to become shorter, e.g. (Hennessy et al., 1997; McGuffie et al., 1999). For the countries around the Baltic, the modelling results of Semmler and Jacob (2004) point to a doubling of extreme rain intensities. With downscaling technique, Skaugen et al. (2004) computed the extreme daily precipitation to increase by 10–50% in large parts of Norway. Later, for northern Europe, Haugen and Iversen (2008) downscaled the rains simulated from eight different global circulation models (GCMs) and many greenhouse gas scenarios and estimated the annual maximum daily rainfall. Dahlström (2006) used expected temperature as a conceptual physical relationship to relate rain intensity to duration and return period. Kao and Ganguly (2011), in same way, used temperature from regional climate models as input to a conceptual physical relationship (basically Clausius–Clapeyron) to show how precipitation extremes will increase over time.

Several studies have addressed the important issue of trends in rainfall in India since the last century. Long term southwest monsoon/annual rainfall trends over India as a whole were previously studied by Parthasarathy et al. (1993), among others. Singh and Sontakke (1999) studied post-monsoon rainfall regionally from 1871 to 1980 as follows: northwest India, 1844–1996; north central India, 1842–1996; northeast India, 1829–1996; west peninsular India, 1841–1996; east peninsular India, 1848–1996; and south peninsular India, 1813–1996. They concluded that these areas do not

possess a significant long-term trend, and were weakly correlated. Recently, Goswami et al. (2006) indicated significant positive trends in the frequency and the magnitude of extreme rain events and a significant negative trend in the frequency of moderate events over central India during the monsoon seasons from 1951 to 2000. Long term trends for the last 50 years indicate a significant decrease in the frequency of moderate-to-heavy rainfall events over most parts of India e.g., (Naidu et al., 1999), (Dash et al., 2009). This was also corroborated by a significant rise in the frequency and duration of monsoon breaks over India during recent decades (Ramesh Kumar et al., 2009; Turner and Hannachi, 2010). The frequency of extreme rainfall events (100 mm/day) have increased in certain parts of the country (Goswami et al., 2006). Future climate studies based on climate model simulations suggest that greenhouse warming is likely to intensify the monsoon precipitation over a broad region encompassing South Asia, e.g., (Lal et al., 2000; May, 2002; May, 2004; May, 2011; Meehl and Arblaster, 2003; Rupakumar K, 2006). However, precise assessments of future changes in the regional monsoon rainfall have remained ambiguous due to wide variations among the model projections, e.g., (Annamalai et al., 2007; Fan et al., 2010; Kripalani et al., 2007; Kumar et al., 2011; Sabade et al., 2011). The simulated precipitation response to global warming by climate models is actually accompanied by a weakening of the large-scale southwest monsoon flow, e.g., among others (Kripalani et al., 2003; Krishnan et al., 2013; Stowasser et al., 2009; Ueda et al., 2006). However, (Rupakumar et al., 2006) studied the effect of climate change in India by evaluating the present day simulation (1961-1990) of PRECIS climate model and reported increase in extreme precipitation along west coast and west central India.

The relation between precipitations in India and global climate phenomena is well known. (Sen Roy, 2006) indicated that the Pacific Decadal Oscillation (PDO) and El Niño-Southern Oscillation (ENSO) have negative relationship with winter rainfall in almost all north and central parts of India whereas SST around the mainland has negative correlation with rainfall in peninsular India. (Singh, 2001) have also shown the negative relationship of pre-monsoon ENSO conditions to the amount of precipitation taking place in north-western and peninsular India. A major shift in total rainfall during recent years has been observed which shows that they might be following periodical cycles of PDO, ENSO and local SSTs, (Sen Roy, 2006). (Kumar and Dash, 2001) showed that the decadal frequency of number of depressions was decreasing in recent years.

2.4 Need for high resolution temporal data

Access to fine time scale rainfall data is of prime importance for IDF analysis among other hydrological applications. However, such data of considerable length are usually not available in most parts of the world. When short series of rainfall data with high time resolution are available stochastic simulation tools can be used to extend the series and generate new series. A possible way forward is to develop necessary rainfall information from the commonly available daily rainfall data. Stochastic simulation tools can be used to extend historical data and generate new fine time scale data, which possess similar statistical properties as the observed ones, (Gaume et al., 2007). Stochastic disaggregation provides possibility of generating fine time scale rainfall

data from coarser resolution. Traditionally there have been two approaches for this. One approach is based on fitting theoretical probability distribution functions to precipitation variables, e.g., (Connolly et al., 1998; Econopouly et al., 1990; Hershenhorn and Woolhiser, 1987). The other approach starts from rectangular pulse stochastic rainfall models and devise ways to use these for disaggregation, e.g., (Bo et al., 1994; Cowpertwait et al., 1996; Glasbey et al., 1995).

An approach to downscale rainfall by modelling the statistical distribution of rainfall in time and space has emerged during the latest decades, i.e., by random cascade processes, (Over and Gupta, 1994; Schertzer and Lovejoy, 1987) and many more. A cascade process repeatedly divides the available space into smaller regions, in each step redistributing some associated quantity according to rules specified by the cascade generator. A generic feature of random cascades is a scaling behaviour, which generally may be defined as a relationship between statistical moments of various orders and a scale parameter. The applicability of scaling and cascade models to temporal rainfall has been demonstrated in a number of empirical data analyses, e.g., (Harris et al., 1996; Hubert et al., 1993; Licznar et al., 2011; Menabde and Sivapalan, 2000; Molnar and Burlando, 2005; Olsson, 1995; Rupp et al., 2009; Svensson et al., 1996; Tessier et al., 1993). Encouraging results for spatio-temporal disaggregation of rainfall have been reported.

The disaggregation studies performed to date have generally concerned model development, calibration, application and evaluation using extensive, high-resolution (time and volume), high-quality precipitation databases. In practice however available high-resolution data for model calibration are often limited to data over short periods of data (e.g., from a measurement campaign) or data not always of the highest quality. Still, these kinds of data must be used in real-world applications supporting design of urban infrastructure. The random cascade model for disaggregation of daily rainfall to higher time resolution is well established and has been applied in varied conditions across the world e.g., in southern Sweden by (Olsson, 1998), British and Brazil stations, (Güntner et al., 2001) and in semiarid areas of Tunisia by (Jebari et al., 2012).

2.5 Urban Flooding and its modelling

Urban areas, where impervious materials cover much of the land surface, are characterized by reduced infiltration and accelerated runoff cause floods that are unrelated to a floodplain. Historically, riverine flooding and flash flooding along floodplains have received considerable attention, e.g., (Parker, 1980). Much effort has gone into proper design and not much has been done on analysing the hydraulic conditions when flooding occurs in the urban setting. Societal and financial consequences of urban flooding are inevitably large as half of the global population resides in urban areas. With increasing population and build up of urban areas, the hydrological and hydraulic properties of these areas are greatly changed, leading to increased flood hazard and damage, (Espey, 1966). Complexities in the urban environment and drainage infrastructure have an inherent influence on surface runoff. This runoff generates urban flooding which poses challenges to modelling urban flood hazard and risk. Accurate simulation requires detailed elevation data. However, high-resolution elevation data are costly and commonly unavailable, hence

only publicly available data sources, e.g., US Geological Survey (USGS) Digital Elevation Models (DEM) and contour maps and ASTER data are typically relied on. The urban flood hazard and inherent complexities associated with drainage infrastructure have in the last two decades received attention, e.g., (Djokic and Maidment, 1991; Djordjevic et al., 1999; Hsu et al., 2000; Mark et al., 2004; Schmitt et al., 2004).

One-dimensional hydraulic methods have been used to study floods in river valleys for a long time. For example, HEC-RAS has been widely used to delineate the regulatory flood plain zone of 100-year or 500-year flood around a river, (Roberson, 1998). Several 2-D hydraulic models were developed and used in shallow rivers and flood plains. Numerous studies have been published, e.g., (Chow, 1973; Jha et al., 2000; Katopodes and Strelkoff, 1997). It is usually caused by local high intensity rainfall and handicapped (e.g., low gradient) drainage systems. Besides using traditional hydrological methods as a primary tool, in recent years 2-D models have been employed to simulate some urban storm-water flood problems. (Iwasa, 1980) and (Toda K., 2001) applied a 2-D numerical model for urban flood simulation in Japan. (Cheng, 2001) summarized the urban flood simulation techniques in China when a 2-D model was used to simulate the storm-water produced floods in the Great Tianjing City in northeast China.

Urban storm-water models such as SWMM, MOUSE/MIKE URBAN, Hydroworks/Infoworks or STORM are widely used to model urban drainage system e.g. (Balmforth, 2006; Elliott and Trowsdale, 2007). Such models provide a good representation of the physical phenomena but, because of their complexity, they are usually not user friendly and are generally limited to technical issues, (Balmforth, 2006). Geographic Information Systems (GIS) is also commonly used to collect and manage the spatial data required as an input for models, (Heaney, 2001). Currently there are only a few examples of such dedicated tools which use post processed data from GIS with ease, (Makropoulos et al., 2001). One such modelling tool that can use data pre-treated with GIS interface is MIKE 21.

3 STUDY AREA, DATA AND METHODOLOGY

3.1 Study Area

The study in the present thesis focused on various aspects precipitation and flooding with respect to climate variability/climate change (detailed in the Methodology section below) in Mumbai, India and Southern Sweden including Skåne and the Gothenburg region.

3.1.1 Mumbai, India

The study was carried out for the city of Mumbai, formerly called Bombay (18°58'30"N 72°49'33"E) is the capital of Maharashtra state and it is located in the south-western part of India. Mumbai is located on the windward side of the Western Ghats of India and receives high rainfall, both in magnitude and intensity, owing to the orographic effect from strong westerly and south-westerly monsoon flows over the Arabian Sea. The average annual rainfall of Mumbai is 2140 mm with monsoon rainfall contributing 96% of the total annual rainfall (**Paper II**). During the monsoon, it usually rains uniformly over the city and severe flooding occurs in many parts of the city. Very heavy rains with intensity of 250 mm/day are not uncommon ($T \approx 2y$), leading to major problems of flooding in the area. The duration of a rainfall storm usually ranges from 30 min to 120 min or more; in some cases it is 3-4 hours. The hourly intensity of rainfall for return period of 20, 30 and 40 years is 60, 65, and 70 mm/hr, respectively (**Paper VI**).

The East India Company started development of Mumbai as a naval base, which subsequently metamorphosed as a large port with flourishing trade and commerce. The city has now developed into commercial capital of the country with 13 million inhabitants. The population density is about 50,000 persons/km². Mumbai is lined by the Arabian Sea on the western side and intercepted by creeks and rivers. The drainage system of Mumbai is a mix of simple drains (nallah) and a complicated network of rivers, creeks, drains and ponds built around 80 years back. At present, the storm-water drainage system consists of a hierarchical network of roadside surface drains (mainly in the suburbs), underground drains and laterals (in the island city area), major and minor nallahs and 186 outfalls. All surface runoff discharges into the rivers and the Arabian Sea. A network of closed drains below the roads has evolved in the city along with drains in the suburbs. Reference is made to **Paper I** for details on the Mumbai drainage system.

Greater Mumbai has witnessed rapid growth of built up areas in past four decades, i.e. 1971–2001. The built up areas has more than doubled from about 25% in 1971 to 52% in 2001. The shift is from coastal wetlands and agricultural/forestlands into urban areas. Coastal wetlands have experienced a substantial decrease from 29 to 19% and land under forests has reduced from 32 to 19%. The region as whole is a lowland, lying on the west of Sayhadri hill ranges. The step-like terraces and layered appearance is

characteristic of the Deccan lava country. The river system consists of five major rivers that drain into the Arabian Sea (**Paper VII**).

3.1.2 Southern Sweden and Gothenburg

Skåne is the southernmost area of Sweden. The biggest city in Skåne is Malmö situated, in the southwest. The other cities included in various studies in the thesis are Halmstad and Göteborg on the west coast north of Malmö, Borås, and Växjö on a 150–200 m high plateau, and Kalmar on the east coast. The annual precipitation is by far the largest in Borås, about 1000 mm, followed by that in Göteborg and Halmstad, which is about 750 mm (**Paper III**). The difference in annual precipitation is mostly due to different winter precipitation in the different cities. The frontal rains are usually coming from the west. The western frontal rains have lost much of their precipitation when reaching Kalmar on the east coast. The annual precipitation is the lowest there, about 500 mm. For all the nine stations of 50-year records in the Skåne area, the meteorological conditions are similar. The annual precipitation is 550 to 650 mm at all stations. All these stations are situated at a low level, below 40 m.

Further Gothenburg was studied in detail for analytical analysis of the situation of flooding and impact of climate change. Gothenburg is the second largest city in Sweden. Approximately 500,000 people inhabit it. It is situated on the west coast of Sweden at the mouth of the river Göta Älv. It lies at 57°42'N, 11°55'E on the longitude-latitude grid. The annual precipitation is about 700 mm; mean maximum annual precipitation is about 800 mm with 37% wet days. The Swedish Civil Contingencies Agency (MSB) has finished an assessment where Gothenburg is considered as one of the 5 Swedish cities at risk of flooding (**Paper VII**). The flooding in Gothenburg is due to the Göta River, the Mölndal River, and the sea.

3.2 Data Sets

The research presented in this thesis was based mainly on metrological data collected from IMD for Mumbai (**Paper II, IV, VI and VIII**), climatic indices data from the National Weather Service, Climate Prediction Centre (NOAA) (**Paper II**), SMHI for southern Sweden (**Paper III**) including Gothenburg (**Paper V**). For analytical review of situation in Mumbai data was also collected from MCGM (**Paper I and Paper VII**) and Göteborg Stad (**Paper VII**) for Gothenburg. Data was also acquired from the CMIP5 database, provided by MOHC (Met Office Hadley Centre) (<http://badc.nerc.ac.uk/home/>) for climate change analysis using GCMs for Mumbai (**Paper IV**) and the ENSEMBLES project coordinated by MOHC for climate analysis for Gothenburg using RCMs. Finally 25m DEM is obtained from ASTER Project (<http://www.ersdac.or.jp/GDEM/E/1.html>) for setting up the flood model (**Paper VIII**). The summary of data used is presented in Table 1. Readers are suggested to refer to different papers for details on the data.

Table 1. Summary of data used in research and presented in this thesis

Organisation /Institute	Data Period	Study Type/Comments	Included in papers
IMD	1951-2004	Daily data for trend analysis, disaggregation and flood modelling	Paper II, Paper IV, Paper VI and Paper VIII
NOAA	1951-2004	Monthly data for climate variability	Paper II
SMHI	1870/1880- 2010 ¹	Daily data for trend analysis	Paper III
MCGM	-	Analytical review of drainage and flood modelling	Paper I, Paper VII and Paper VIII
Göteborg Stad	-	Analytical review of drainage	Paper VII
CMIP 5 (MOHC)	1975-2099	Daily data for climate change studies	Paper IV
Ensembles (DHI)	1961–2009	Daily data for climate change studies	Paper V
ASTER DEM	-	Flood modelling	Paper VIII

3.3 Linear and Non Linear Data Analysis

3.3.1 Univariate and Multivariate statistical Analysis

The basic daily rainfall data for Mumbai (**Paper II**), monthly means, median, percentiles, seasonal totals, standard deviation (SD), and percentage contribution to annual rainfall were computed monthly and season-wise viz., pre-monsoon (March–May), southwest monsoon (June–September), post-monsoon (October–November) and winter (December– February). Descriptive statistics and rainfall distribution (CDF) were calculated for Gothenburg (**Paper V**) to be compared with RCM data of same time and spatial resolution. The daily rainfall frequency distributions of the observed data and the model simulations were determined and compared with focus on rare events, but also the number of wet days was considered. Descriptive statistics were calculated for observations and predicted data sets including mean, median, and standard deviation. This was then followed by calculation of coefficient of variation (CV) in monthly precipitation over a year and averaging over all years and seasonal events (winter and summer) to analyse variability in the annual and seasonal patterns. The fit to different theoretical distributions was investigated. Cumulative

¹ Various starting periods for different stations (some of the data was from reports published by SHMI and parts were available in digitized form).

distribution $F(x)$ can be defined as the proportion of observations lying below a certain value x . The cumulative distribution for all models simulation runs was compared with observed data.

Multivariate data analysis provides tools for handling complex data, such as climatological parameters. The research described in these thesis used two multivariate techniques namely, principal component analysis (PCA) and singular value decomposition (SVD). PCA is a multivariate technique that is widely used in various fields of research for noise reduction, data simplification and for multivariate visualisation and prediction. PCA transforms the data set in order to concentrate the *variance* in as few variables as possible. The lucid exposition of PCA by (Kutzbach, 1967) was instrumental in promoting the use of this technique in climate research. PCA was used to relate climatic indices with precipitation in Mumbai in **Paper II** and compare observed precipitation with different RCM output results in Gothenburg in **Paper V**.

SVD is a fundamental matrix operation, a generalization of the diagonalisation procedure that is performed in PCA to the matrices that are not squared or symmetric. SVD was first used in meteorological context by (Prohaska, 1976). As applied by (Bretherton et al., 1992), SVD is performed to the cross-covariance matrix of two fields and isolates the linear combinations of variables within the fields that tend to be linearly related to one another by maximizing the covariance between them. SVD is used in **Paper II** to determined relations between precipitation in Mumbai and climatic variability using climatic indices. Both the above methods isolated important coupled modes of variability between time series of two different fields.

3.3.2 Extreme events/Trend Analysis

The linear regression method is widely used to determine long-term trends seasonally, annually, and for daily maximum precipitation e.g. (Gadgil and Dhorde, 2005) among many others. The non-parametric Mann–Kendall test, is another popular statistical method used by contemporary climatologists e.g. (Gadgil and Dhorde, 2005; Tomozeiu et al., 2006). The major advantages of this test are that there is no assumptions about distribution are necessary and it is directly applicable to climate data for a given month or season. The procedure of carrying out this statistical test was outlined by (Mitchell et al., 1966). The data, for Mumbai, was subjected to Mann–Kendall test for trend analysis in different time periods from 1951 to 1980, 1981 to 2004 and also from 1951 to 2004 for all the seasons and annually so as to see changes in precipitation on decadal basis (**Paper II**). The data were also analysed for daily extreme/maximum precipitation events per year.

In **Paper III**, trends over time were analysed using Mann–Kendall test and linear regression with t-test. Trends were considered significant at the 2.5% level (5% double-sided) and weakly significant at the 5% level (10% double-sided). Trend tests were done on rain amounts and on the number of annual events exceeding certain values. For events with a frequency of less than one per year, the trend analysis was performed on the number of events per decade.

Extreme event analysis was performed using the annual maximum of each year by applying General Extreme Value (GEV) or Gumbel distribution and also using the

peak over threshold (POT) approach with Pareto distribution (**Paper III**). The relation between annual rainfall and daily rainfall was determined from simple linear regression followed by t-test. Tests for differences in means for different periods were performed with t-test, assuming two normal distributions. The samples were large, so the central limit theorem enabled the use of such tests also for non-normal samples. Account was taken of the different lengths of the observation data in different periods. In **Paper V** extreme events of precipitation were studied by determining annual-daily maximum, two-day, three-day, and seven-day annual maximum. Annual maxima were considered for fitting Generalized Extreme Value distribution and determining return periods.

3.4 Climate change analysis

3.4.1 Bias correction

In **Paper IV**, the GCM data were subjected to Distribution Based Scaling Method (DBS) (Yang et al., 2010) to downscale and bias-correct the climate model data for both historical and future projections. This was performed to study effects of climate change on precipitation in Mumbai. The DBS approach used two steps: (1) spurious drizzle generated by the GCM model was removed to obtain the correct percentage of wet days and (2) the remaining rainfall was transformed to match the observed cumulative probability distribution in the baseline period. In step 1, simulated and observed daily rainfall was sorted in descending order. The cut-off value was then defined as the threshold that reduced the percentage of wet days in the simulation to that of the observations. Days with rainfall amount larger than the threshold value were considered as wet days and all other days as dry days (Yang et al., 2010). In step 2, gamma distributions were fitted to the daily rainfall data on wet days, both for the observational and the climate model data. DBS applies a gamma distribution because of its ability to represent the typically asymmetrical and positively skewed distribution of daily rainfall intensities (Haylock et al., 2006). This was followed by evaluation of DBS scaling procedure by comparing different climate statistics generated including accumulated rainfall, mean, standard deviation, coefficient of variance (CV), and percentage to annual rainfall for observed, raw GCM and bias-corrected GCM data. A mean annual cycle curve using a 31-day moving average for the baseline period was plotted to evaluate the seasonal cycle in a continuous way. Extremes of rainfall were studied by one-day, two-day, three-day and seven-day annual maxima, for all years of a particular period individually and averaged over the whole analysis period using Lognormal and Gumbel distribution. Annual maxima were then fitted using log normal and Gumbel distribution function (Generalized Extreme Value distribution) and return periods were determined for 50 and 100 years. Percentage frequency of rainfall events in Observed, Raw GCM and GCM DBS corrected data were also calculated.

3.4.2 Impact Analysis

The analysis of the climate change signal in Mumbai was done for all the nine GCM projections and for the periods 2010-2040, 2041-2070, 2071-2099, and 2010-2099 for studying near, intermediate, distant, and long-term climate future using various

statistical means and relative change with respect to baseline projections (**Paper IV**). Extreme values statistics were calculated for all projection periods using Log normal and Gumbel distribution function for return periods of 50 and 100 years as suggested by (Majumdar and Sawhney, 1965). The average of all the projections was also studied to assess the most likely changes, based on the nine-member ensemble. The extreme value statistics in all projections and future periods were subjected to Mann–Kendall and student t test (linear regression) for trend analysis in only long-term (2010-2099) at 5% two-tailed test.

3.5 Random Cascade modelling, disaggregation and IDF development

3.5.1 Disaggregation and cascade modelling

As pointed out in section 2.4, a way of estimating short-term rainfall from observations over longer periods is by temporal disaggregation. One approach along this line is to fit theoretical probability distributions to different rain characteristics, e.g., (Schertzer and Lovejoy, 1987; Tessier et al., 1993). Another approach is cascade-based disaggregation, combining an underlying hypothesis of cascade-type scaling with empirically observed features of temporal rainfall. The cascade-based disaggregation model for continuous rainfall time series used in this study was based on the principles suggested by (Olsson, 1998). (Güntner et al., 2001), and (Jebari et al., 2012) showed that the approach is applicable for cascading from 24 hours to 1 hour duration in different climatic conditions. Constant, scale-invariant parameters were assumed, which, however, were found to be climate dependent. The approach was adopted in **Paper VI** for disaggregation of daily values to 10 minutes temporal resolution. The rationale behind the disaggregation approach is to split each time interval (box) at a given resolution (for example 1 day) into two halves of the original length ($1/2$ day). The procedure is continued as a cascade until the desired time resolution, i.e., first to $1/4$ day, then to $1/8$ of a day and so on (Figure 1). Each step is called a cascade step, with cascade level 0 as the longest time period with only one box (in the example a day). The rain volume of a box at an upper level can be distributed between the two lower boxes (probability $P_{x/x}$ or all the rain can go into either of the boxes (probability $P_{1/0}$ or $P_{0/1}$). The distribution of the volume between the two shorter intervals (boxes) is determined by multiplication with the cascade weights (W), the distribution of which is often termed the cascade generator, which fulfils the prescribed properties. The process is repeated for a number of levels, defined by the cascade step cs , until the rainfall is disaggregated into the desired resolution. The procedure was also tested for suitability in the study area, Mumbai, and then used for extreme event analysis.

Cascade Step:

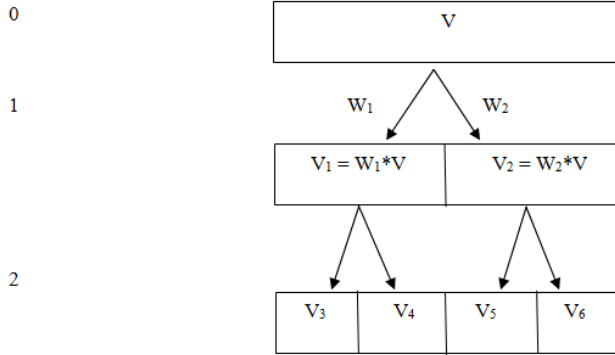

$$W_1, W_2 = \begin{cases} 0 \text{ and } 1 & \text{with probability } P(0/1) \\ 1 \text{ and } 0 & \text{with probability } P(1/0) \\ W_{X/X} \text{ and } 1 - W_{X/X} & \text{with probability } P(X/X) \end{cases}$$

where, $0 < W_{X/X} < 1$

$$\text{Volume} = V = V_1 + V_2 + V_3 + V_4 + V_5$$

$$P(0/1) + P(1/0) + P(X/X) = 1$$

Figure 1: Cascade process principle in one dimension. Between two cascade levels, each interval is divided into two halves. The volume in each half is obtained by multiplying the total interval mass by a weight W_i (adopted from **Paper VI**).

3.5.2 IDF development

Using long time series of rain observations that is used to compute rain volume over fixed durations can be calculated and then IDF curves can be calculated. In **Paper VI** the disaggregated data were used to compute IDF relations. Annual maxima were extracted from the records for all durations. The durations that were taken in consideration were 10, 20, 40, 80, 160, and 320 min. The annual extreme data were then fitted to a probability distribution in order to estimate rainfall quantities of very low frequencies. The fit of probability distribution was performed in order to standardize the character of rainfall. Gumbel's extreme value distribution was used for fitting the extremes, as is the standard procedure in governmental agencies in India. For not so extreme events, the return periods were simply estimated from the number of events in ~50 year data considered, for example the 5th largest value would correspond to 10 year return period.

3.6 Situation analysis

In the study described in **Paper I and VII**, data from different agencies were used to perform situation analysis in Mumbai and Gothenburg. Analysis was based on the current scenario for these cities and their drainage system along with policy analysis. A SWOT analysis for Mumbai was also performed in **Paper VII**.

3.7 Flood modelling and analysis

In **Paper VIII**, an attempt was made to model flood zones in event of heavy rainfall in Mumbai. Rainfall data for all the 8 scenarios (disaggregated values) were used to build a time series files. Then a bathymetry was created. The rainfall data used for modelling had 10min time step. Statistical analysis of different time series was also performed for all scenarios so that modelling results can also be compared in respect to data choice from the entire period. Boundary conditions in the model are programme detected and follow the natural course. All the model simulations were made with same input of DEM (resolution 30m). The simulations started with a dry surface with drying and flooding depth of 0.002 and 0.003m respectively. Different parameters were calculated for the whole area including maximum height of water depth, time of maximum height, maximum flux, time at maximum flux, H water depth, U velocity and V velocity. Effects from tides were not considered in the study due to lack of data.

4 RESULTS

4.1 Linear and Non Linear Data Analysis

4.1.1 Univariate and Multivariate statistical Analysis

In the research presented in this thesis univariate statistics were calculated to determine the characteristics of rainfall in Mumbai (**Paper II**) and usefulness of these methods in predicting future climate scenarios without bias correction (**Paper V**). It was evident from these procedures that the various statistics indeed present an overall picture of the situation in the area. Different applications of same climatological parameters were also presented through this work. Precipitation data is used to apply in various hydrological applications with or without post processing. From **Paper II**, it was concluded that most of the rainfall (96%) in Mumbai is during the monsoon season which then have greater implications in this case. Management strategies are ought to be made keeping the amount and duration of rainfall received. Whereas in case of Gothenburg, **Paper V**, univariate statistics proved valuable in comparing the output from climate models with that of observation data. It was concluded that these procedures could be used in conjunction with other methods for bias correction of data from climate models on finer spatial resolution. Mean and other statistics were also presented in **Paper III** for different stations in southern Sweden for determining precipitation characteristics.

In the present research, PCA and SVD were found to be valuable resources, which can be used for various applications and information extraction from datasets. In **Paper II**, it was observed that precipitation in Mumbai is closely related to EA, IOD, and NINO 3.4 climate indices (Figure 2). It can be easily observed that precipitation in Mumbai was in different quadrant that the related climatic indices. This was further supported by observations from SVD procedure where heterogeneous correlation supported the observations. The result of SVD confirmed the relationship between precipitation and climatic variables in the global scenario accounting for most of variability observed in precipitation in Mumbai. The aspects of variability of precipitation with climatic phenomena are useful to study. For example, results can be used in future models that can be developed for long term prediction of rainfall as the global climate phenomena seem to explain great part of variability in precipitation.

In case of Gothenburg, **Paper V**, PCA proved to be a valuable tool in predicting the nature of output from RCMs with respect to observations, in turn depicting the impact of particular RCM in predicting precipitation at the study area (Figure 3). The proximity of different RCM to that of observed data in different quadrant gives an idea of variability explained by them.

Results

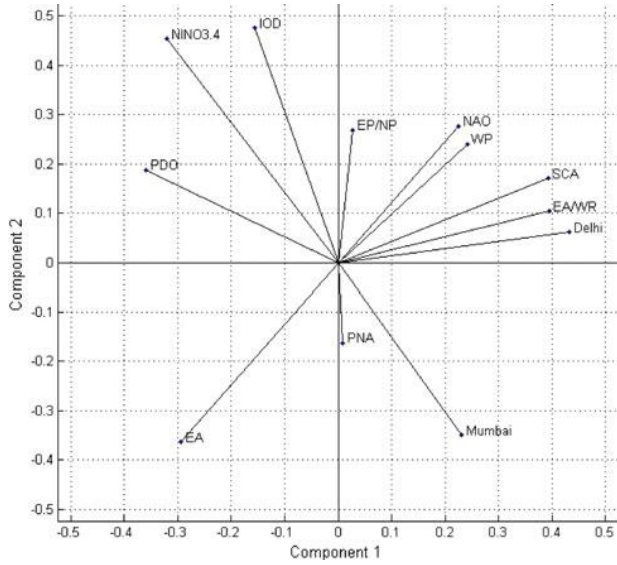

Figure 2: Bi-plot of first four modes of PCA showing component 1 and component 2 (adopted from **Paper II**).

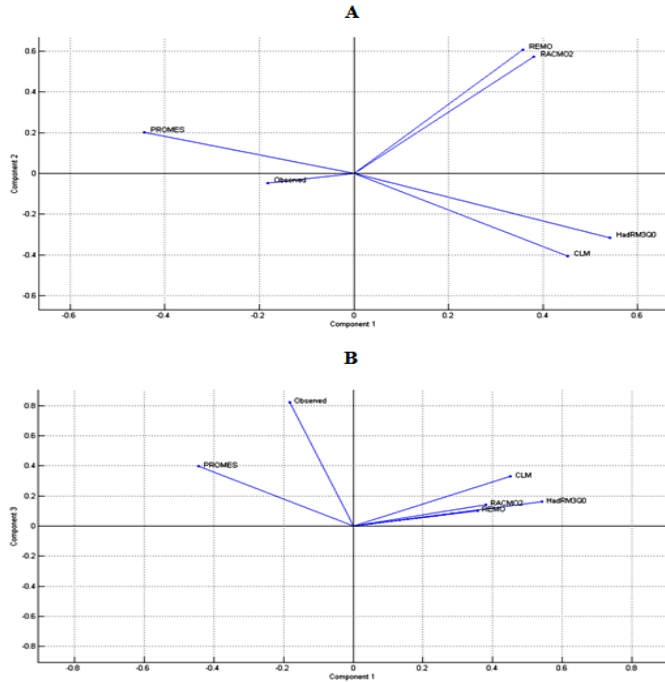

Figure 3: PCA using Component 1, Component 2 and Component 3. A represents plots of component 1 with that of component 2 and B represents component 1 with component 3 (adopted from **Paper V**).

4.1.2 Extreme events/trend analysis

This section presents the results of extreme event and trend analysis in Mumbai (**Paper II**), Southern Sweden (**Paper III**), and Gothenburg (**Paper V**). Mann-Kendall test was used as a significance test in all the cases. For Mumbai, **Paper II**, the data were divided into 3 parts to analyse the trends and significance in 1951–2004, 1951–1980, and 1980–2004, respectively. The mean annual rainfall over Mumbai showed a long-term significant negative trend that was statistically significant at the 0.05 levels. The negative trend in annual rainfall was statistically significant when considered the period of 1951–1980; however, the apparent positive trend during the 1981–2004 periods was not statistically significant. Mumbai also showed a significant negative trend for the southwest monsoon season. All trends in rainfall were tested for significance at 0.05 level using the Mann-Kendall test. As for seasonal precipitation, trends at Mumbai were significantly negative in southwest monsoon and annual seasons during 1951–1980 and 1951–2004. Pre-monsoon (March–May) rainfall showed statistically insignificant increasing trend in both periods. The increase was sharper during the later period of study. Southwest monsoon (June–September) rainfall was major part of rainfall in whole data period. There was a significant decreasing trend in rainfall during the 1951–1980 periods and an insignificant increasing trend during 1981–2004. Also, the monsoon rainfall decreased from 2,230 mm in 1951–1980 to 1,840 mm in 1981–2004. The decreasing trend during the 1951–2004 in monsoon rainfall is statistically significant at 0.05 levels. Post-monsoon (October–November) rainfall depicted decreasing trends in both data period with slight increase above the long-term mean in 1981–2004. Winter (December–February) rainfall had a slightly increasing tendency during both data periods, which was not statistically significant.

As for the extreme events, maximum daily rainfall per year showed a significant decreasing trend during 1951–1980 and then non-significant increasing trend after 1980–2004 (Figure 4) that correlated with the climatic indices presented above with PCA. The overall trend was significant and decreasing for the full 53 year period (**Paper II**).

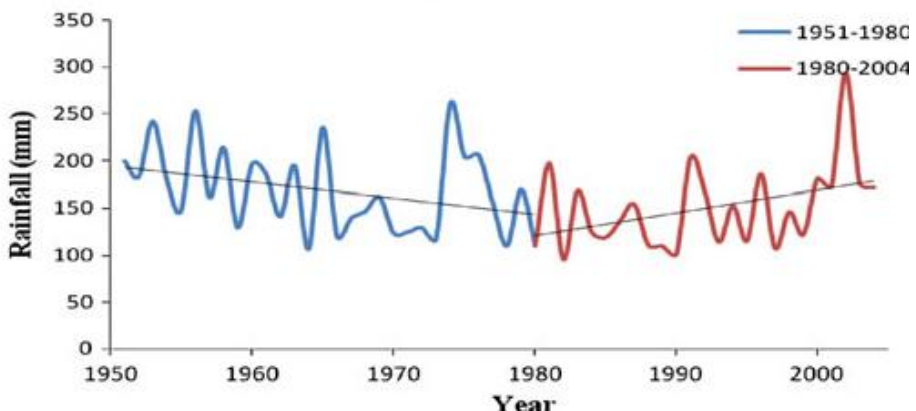

Figure 4: Maximum daily rainfall per year at Mumbai during 1951–1980, 1981–2004, and 1951–2004 (adopted from **Paper II**).

In Southern Sweden, Paper **III**, the annual precipitation was found to have increased over the last 100–135 years. The precipitation increased by about 20%. The increase was strongest for Borås, 1.8 mm/year, where the annual precipitation also was largest. The winter precipitation increased, but the summer precipitation did not increase. The annual increase was faster the last 50 years than the mean increase rate over the whole period. The focus of the Swedish study was on daily rains. In general it was found that the frequency of modest rains, 20 mm/day increased over the last 100 years, but that of the more intense rains, 40 mm/day or more, did not. While there is a relation between the number of modest rains and annual precipitation, there is not such a relation between annual precipitation and the more severe rains. Some statistics are shown in Table 2.

The extreme values with return period of at least 20 years were determined using the Gumbel distribution, the GEV, and the POT approach for the Swedish data, Paper **III** and Table 2, but only Gumbel for the Mumbai rains, Paper **VI**. The less extremes were determined simply from the ranking position. The 10-year storm in Sweden was in the range 45–55 mm, while in Mumbai it was 117 mm. In Sweden the lowest 100-year daily rain, about 60 mm, was found to be in Borås, Karlshamn, and Kalmar. It was noted that Borås had the largest annual precipitation and Kalmar shared the lowest. The highest daily rain observation at all the Swedish stations was from Växjö, 145 mm in 1945. Different distributions were used to find the probability of the most extreme rains. The 100-year rains determined by the GEV and Gumbel approaches were almost exactly as the POT-determined rains.

Usually a limited number of years with precipitation data were available for extreme value analysis. Using a fixed number of previous years the T-year storm can be determined as a moving value from year to year. To see how extreme value changes over time, 25 years of data were continuously used for evaluation of return periods of different rain intensities. For example in year 2005, the 25 years included data from 1980 to 2004 and in year 2006 data 1981 up to 2005. When one year was added another was dropped. An example is shown in Figure 5 for Lund. Gumbel distribution and the peak-over-threshold method were applied using the 10 largest values over the 25 years for the POT-approach. The magnitude of the 50-year storm varied much over the years. The highest 50-year storm was found around 1960 and the lowest at present. Using the whole data set the 50-year storm was about 65 mm/day.

Similar observations were made for Gothenburg, **Paper V**, when the extreme value analysis was done. The scope of **Paper V** included comparison of the extreme values at observation station to that of RCMs output and thus are not presented here. Readers are suggested to refer to the appended paper for details.

Results

Table 2: Annual daily maximum rainfall and frequency of daily storm exceeding 20 mm, 30 mm and 40 mm for the cities with long records (Adopted from Paper III)

	Lund	Malmö	Krist	Karlsh	Halm	Kalmar	Växjö	Gtbg	Borås
Start year	1873	1921	1878	1873	1873	1875	1920	1873	1884
Annual	630*	550*	560*	564*	752*	465*	650*	760*	940*
Daily max	32.4	32.4	33.4	30.8	35.0	29.2	33.3	34.6	36.2*
--1930	32*		31	30	34	29		35	34
1931-1960	35	30-0	36	31	37	29	36	33	36
1961-	32	33	33	31	36	290	32*	350	37
P>20 mm	2.6*	2.20	2.50	2.5	3.7*	2.0*	2.4	4.3*	6.4*
-1930	2.3		2.30	2.3	3.31	1.7*		4.2	5.40
1931-1960	2.3	2.2	2.9-0	2.8	3.45	1.9	2.4	3.6	5.5
1961-	3.00	2.2*	2.50	2.5	4.40	2.10	2.4*	5.0*	7.8*
1990-	3.4*	3.0	3.2	3.0	5.4	2.5	2.9	6.00	9.2
P>30	0.72*	0.60	0.67	0.55*	1.00	0.52	0.500	0.96*	1.43*
-1930	0.61		0.67	0.38	0.93	0.60		1.00	0.87
1931-1960	0.80	0.48	0.57	0.67	0.76	0.46	0.50	0.88	1.50
1961-	0.82	0.61	0.78	0.69	1.2	0.49	0.64	1.10	1.90
1990-	1.05	0.68	0.76	0.77	1.9	0.75	0.65	1.27	2.27
P>40	0.21	0.20	0.22	0.19	0.35	0.16	0.18	0.26	0.40
-1930	0.20		0.21	0.14	0.26	0.130		0.28	0.30
1931-1960	0.27	0.10-*	0.27	0.21	0.45	0.29	0.21	0.28	0.46
1961-	0.22	0.24	0.22	0.24	0.41	0.14	0.18	0.25	0.46
1990-	0.29	0.23	0.28	0.32	0.55	0.26	0.26	0.28	0.45

*indicates significance level 2.5% (5% double sided) or better and o better than 10% (double sided). The 40 mm events have not been analyzed for trend. The 30 mm events were analyzed for trend only for the full investigating period and with number of events per decade. Negative sign next to the trend mark denotes decreasing trend

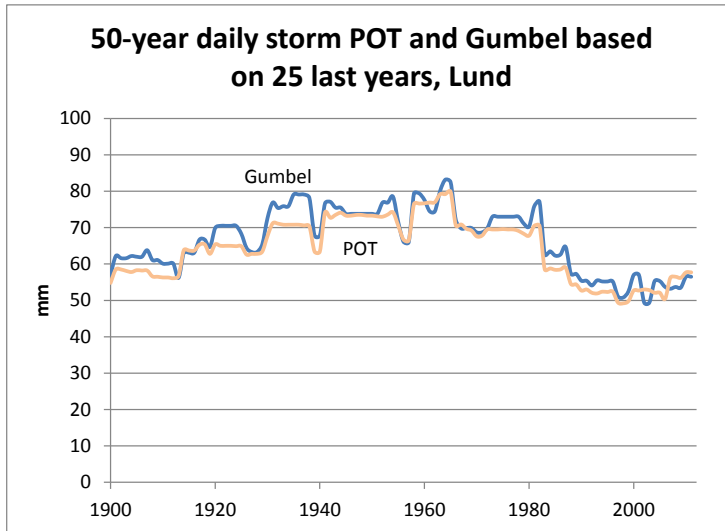

Figure 5: Fifty-year daily storm in Lund determined year-by-year using the 25 previous years: Gumbel distribution (dark color) and POT-approach (light colour) using the 10 highest values in the 25 years (adopted from **Paper III**).

4.2 Climate change Analysis

This section deals with changes in precipitation of Mumbai in future climate scenarios. We used 9 GCM model scenarios for assessment of future changes in precipitation over the study area. Since raw GCM data cannot be used directly for impact studies due to their limitations of representing local/regional characteristics a bias correction method was applied, as explained below in section 4.2.1. This was followed by investigation of future trends in section 4.2.2.

4.2.1 Bias Correction

The DBS bias correction method was adopted in **Paper IV** to scale the output from different GCMs used in the study. The method was further evaluated using varying statistical methods with observations in the baseline period 1975-2004. It was observed that there is marked improvement in the reproduction of climate statistics for both models after post-processing by DBS in comparison to the raw model and it can be inferred from Appendix 1 of **Paper IV**. Especially, the scaling procedure was able to reproduce the pattern of rainfall during different seasons. The monsoon season, which accounts for nearly 96% of rainfall (**Paper II**), was well represented in the scaled data, although it was observed that there was a slight overestimation of rainfall in the post monsoon season (especially for September), while rainfall in June is underestimated, indicating a delayed onset of the Monsoon season in the GCMs (see also Figure 6). It can also be inferred from Figure 6 that DBS methodology was not able to correct this late onset of monsoon in the GCMs, and the case have to be same when we are analyzing future projections. The systematic error in the monsoon onset can be attributed to bias in GCM data and not in DBS methodology. This can

also be observed for individual months in monsoon season where they show a slight shift in the amount of rainfall received compared to observed data.

Extreme value statistics were also improved in the DBS corrected data as compared to the raw GCM output and this can be observed from Figure 7 for 1 day, 2, 3, and 7 consecutive days. In case of raw GCM data the extremes were below the observed values, (Figure 7) considering the wide variety of scales. The figure represents the maximum precipitation observed in different time periods (1, 2, 3, and 7 consecutive days) for observed, raw and DBS corrected GCM data for 2 models. It was also inferred from statistics that the DBS methodology was able to reproduce the percentage frequency of high rainfall. The raw GCM data showed a lower number of dry days (i.e., days with no rainfall), and underestimated the frequency of intensities above 40 mm.

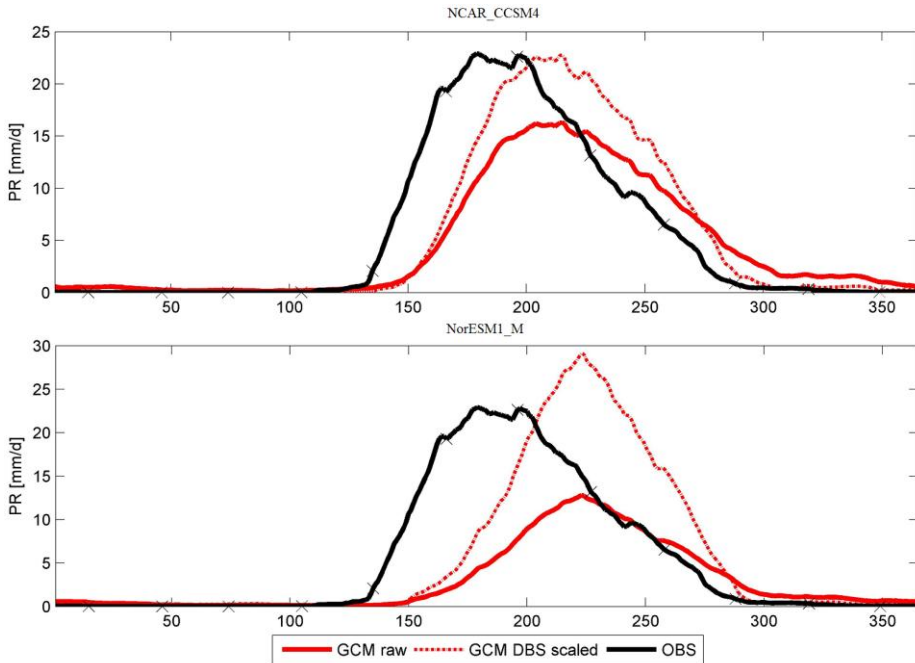

Figure 6: Mean annual cycle in the 30 year baseline (1975-2004) period by a 31 day moving average for Observed, Raw GCM and DBS corrected GCM data (adopted from **Paper IV**).

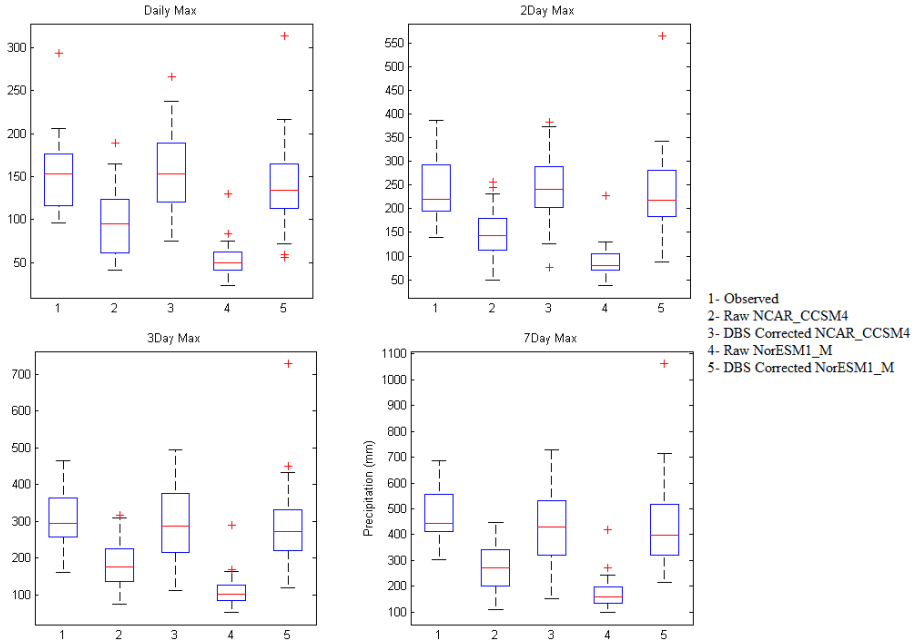

Figure 7: Box plots of extreme Value Statistics of Observed, GCM raw data and GCM DBS corrected data for 1, 2, 3, and 7-day Maximum values compared to observed baseline (Y axis presents precipitation in mm) (adopted from **Paper IV**).

4.2.2 Impact Analysis

The bias correction method was applied to the raw output data from GCMs for future projections. Impact analysis, in **Paper IV**, was done on 30-year basis, but in the present thesis only long-term future analysis is presented. Trend analysis for the entire future period is presented in Table 3. It can be observed from Table 3 that 4 out of 9 models were suggesting a significant positive trend in the extreme rainfall including the BCC_CSM1.1, the INM_CM4, the NCAR_CCSM4 and the NorESM1_M with total daily (one day) mean maximum up to 160 mm for all the models. Three out of nine projections show a decreasing trend but insignificant at 5%. It should also be noticed that the average of all the projections also points towards a positive trend in daily events for both student t-test and Mann-Kendall analysis. It should also be noted that six out of nine projections are indicating a positive trend in annual maximum daily rainfall. An average maximum for 50 year return period rainfall as 310 and 295 mm using log normal and Gumbel distribution whereas 340 and 325 mm for 100 year return period. The maxima (T50 and T100) range from 250-375 mm for different models. This is relatively higher than the observed values.

Table 3: Extreme events statistics and trend analysis, for annual daily maximum precipitation, using student t test and Mann Kendall test (Figures in bold are significant at 5% in two tailed test) during period 2010-2099 (adopted from **Paper IV**).

Model	Mean	Correlation Coefficient	Student t-test (t)	Mann-Kendall Test (Z)
BCC_CSM1.1	153.8	0.1	1.9	1.9
CanESM1.1	163.2	-0.1	-1.5	-1.2
INM_CM4	149.7	0.2	2.07	1.8
IPSL_CM5A_MR	158.2	0.06	0.01	0.3
NCAR_CCSM4	178.5	0.2	2.3	2.9
NorESM1_M	148.2	0.2	1.9	2.4
CERFACS_CNRM_CM5	163.5	-0.1	-0.9	-1.19
MPI_ESM_LR	169.3	-0.1	-1.5	-1.4
HadGEM2_ES	162.2	0.06	0.01	0.6
Average	160.7	0.06	0.4	0.6

4.3 Random Cascade modelling, disaggregation and IDF development

4.3.1 Disaggregation and cascade modelling

In **Paper VI**, a random cascade model for rainfall disaggregation in the study area was applied to estimate short-term rainfall from daily data, due to lack of high-resolution temporal data. It should be noted that the same data from IMD (Indian Meteorological Department) were used as in **Paper II** and **Paper IV**. The output from this study was then used for flood modelling in **Paper VIII**. Performance of the model was also tested in the study area at each cascade step and is compared in Table 4. The agreement was very good for the three lower cascade steps (larger durations ~24-6 hrs) as noticed in terms of zero values, number of events more than 25 mm and maximum rainfall, mean and standard deviation (Table 4). At higher cascade steps the number of zero events and the mean was well determined but not the high values. The computed maximum was too low (about 20%) for durations 80 and 160 min, and too high (around 40%) for durations 10 and 20 min. The fraction of no rainfall periods and the number of large events were very well described when the duration was 6 hours or more. Number of events more than 25 mm and percentage of zero rainfall were overestimated for 20 min and 10 min data. Mean and S.D. were well preserved in all the cascade steps. A difference of up to 10 mm was noticed in cascade step 7 when we had 10 min data. Overall the extreme values for 1 hr durations and above were well preserved and were well related to observations presented by (Deshpande et al., 2012), where the authors studied observations from the same station up to 1 hr of temporal resolution.

Table 4: Rainfall characteristics related to the observed and model generated series from data period July – Dec, 2006 (generated series data are mean of all 100 realizations) (adopted from **Paper VI**).

Scale	Time Series	Zero Values (%)	No. Of Events > 25 mm	Maximum (mm)
1280 min	Observed	44.6	18	265.6
	Modelled	44.6	18	265.5
640 min	Observed	51.2	19	188.6
	Modelled	51.4	22	173.6
320 min	Observed	58.3	22	125.7
	Modelled	57.9	21	117.0
160 min	Observed	68.1	19	102.8
	Modelled	65.1	16	86.0
80 min	Observed	77.1	11	82.1
	Modelled	72.9	11	62.7
40 min	Observed	84.0	7	41.6
	Modelled	80.1	7	48.3
20 min	Observed	88.8	0	24.1
	Modelled	86.0	4	36.2
10 min	Observed	92.1	0	18.2
	Modelled	90.4	2	27.4

The model thus overestimated the variability with longer duration's, i.e., lower cascade steps and equal in the higher cascade steps. It is seen that the model performed well in preserving extremes up to 5 cascade steps as shown in Table 4. The model overestimated daily maximum values at 6th and 7th cascade steps. (Güntner et al., 2001) reported overestimation of the extreme one hour rain intensities, more so for the British stations than for the Brazilian stations. The disaggregation of the Mumbai-data showed clear overestimation of the number of events and of the extremes only when durations 10 min and 20 min were considered. The intense storms were simulated well for time scale of 40 minutes.

4.3.2 IDF development

After the parameters were determined from the above procedure and the disaggregation was performed on the 1951-2004 daily rain data and the new computed rain series were used to determine IDF curves, **Paper VI**. The derived relations for Mumbai are shown in *Figure 8*. From the graph it is seen that intensity and frequency of extreme events in Mumbai were high compared to the current

design standards in the city. The intensity of 10 min duration rainfall was 125 mm/hr, 137 mm/hr and 150 mm/hr for return periods of 20, 30, and 40 years, respectively.

For the return period of 20, 30, and 40 years, 30 min duration rainfalls were 87, 95 and 102 mm/hr, respectively, and 60 min duration is 60, 65 and 70 mm/hr, respectively. 30 years are considered the life expectancy of urban infrastructure and recommended by Central Public Health and Environmental Engineering Organisation (CPHEEO), Ministry of Urban Development, Government of India. The current design standard for Mumbai city is only 25 mm/hr at low tide (City development plan 2005-2025, Municipal Corporation of Mumbai). According to Intensity-Frequency relation of *Figure 8* it corresponds to return period of less than a year. The established extreme values from the IDF curves are comparable to those of a study performed by (Deshpande et al., 2012) where the authors outlined the extreme events for 1, 3, 6, and 12 hrs for Mumbai station. It can also be noted that the 1 hr largest rainfall for Mumbai in the study is 113 mm, as observed from data period 1969-2004, this was comparable to the established IDF relations.

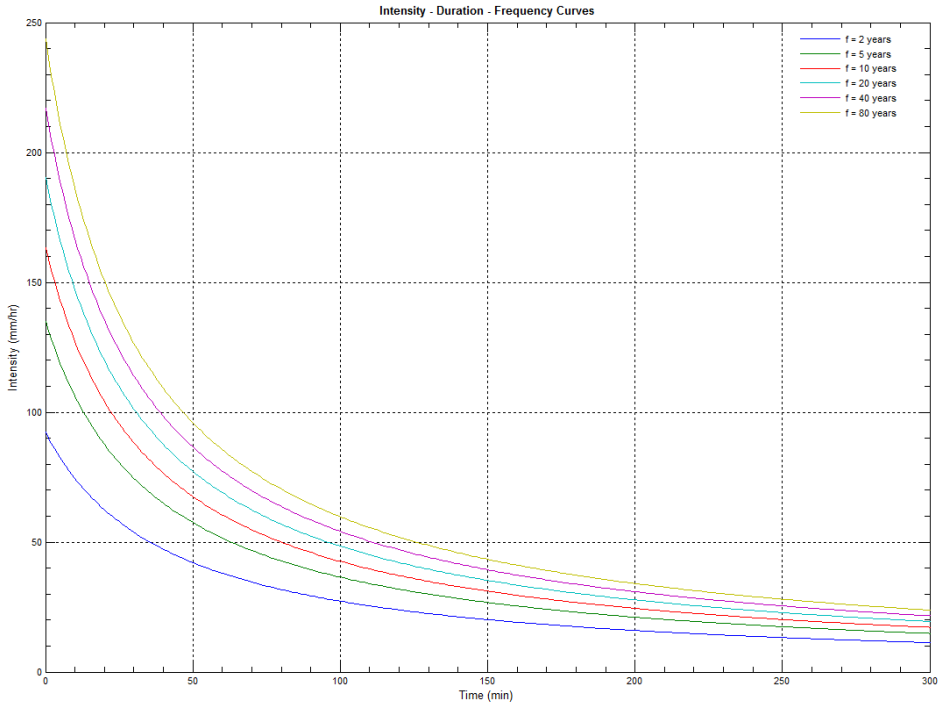

*Figure 8: Historical IDF curves for the city of Mumbai as represented by disaggregated data for the period 1951-2004 (adopted from **Paper VI**).*

4.4 Situation analysis

The situation for Mumbai was analysed in **Paper I** and **Paper VII** with special emphasis on drainage system and events of 26 and 27 July, 2005. The present storm water drainage system in the city, which was put in place at the beginning of the 20th Century, is 70 years old and about 480 km in length. It is capable of handling rain intensity of 25 mm per hour at low tide (can be derived from IDF curves developed in **Paper VI**). This amount is generally exceeded on a routine basis during the monsoon season in Mumbai (further exemplified in **Paper VIII**). The drainage system works with the aid of gravity. Parts of the city like the Bombay Central and Tardeo are below sea level. Along the shore fringe, extensive areas are flooded during high tide and during the heavy monsoon rains. Many low lying areas are flooded and do not get drained. Some of the main problems related to the storm water drainage system of Mumbai are elaborated on below:

- There are no maps of underground cables and pipes: Thousands of underground cables (telephone, water pipelines) need to be mapped, and in some cases, shifted to accommodate the restructured drains.
- Slums along drains: The large number of people living on the top of and adjacent to the existing drains needs to be displaced and rehabilitated.
- Lack of civic sense: This results in clogging of drains, due to debris and garbage being disposed of in them.
- Lack of proper maintenance: The Brihanmumbai Municipal Corporation (BMC) often does not complete cleaning the drains before the monsoon sets in. Work is also not done properly; garbage is left on the sides of the road and when it rains, it returns back to the drains, thereby choking the water passage.
- The gradient of drainage pipes is often too small and affected by tides.
- A large number of drains are of inadequate capacity.
- Poor workmanship and lack of attention to proper repairs when the drains have been punctured to construct utility services has left many of these locations in a poor state of structural repair.
- Interconnection of storm water and sewerage networks.

The situation was analysed using SWOT analysis in **Paper VII**, Table 5. Tidal variations have huge impact on flooding and the water logging situation as all the discharge from SWD and treated sewage is going into the Arabian Sea. Runoff from the city is retarded causing high water stage on the streets because of too small gradients, mud flats, manmade inappropriate levels of outfalls, poor placement of gullies, loss of holding ponds due to land development, new impermeable surfaces, encroachments on drains, enhanced silting and choking of drains due to sillage/sewage inflows and garbage dumping in drains, obstruction due to crossing utility lines, etc.

Table 5: Key issues and strategic plans for the city of Mumbai (adopted from **Paper VII**).

Key Issues	Strategy options/plans
Encroachments alongside drains, disturbing catchments runoff	Various recommendations suggested by the BRIMSTOWAD report 1993 and subsequent studies:
Adulteration of storm-water in drains by garbage and sewage infusions, which are in turn discharged into the environmentally sensitive creeks and the sea	Divert sullage water flow to sewage pumping station, improve flood gates at various places and increase the capacity of drains wherever necessary
Increase in overall runoff coefficient	Remove obstruction of water pipe lines, cables etc from SWD
Silting of drains and poaching of space by utility lines, reducing carrying capacity	Widen, deepen and extend the nallahs and outfalls, remove encroachments along the nallahs/drains and rehabilitate them
Structural deficiencies due to age and poor workmanship	Desilt and maintain storm-water drain during rainy season
Project implementation hurdles:	Formation of coordination committee comprising representatives from all associated stakeholder agencies to sort out institutional/procedural issues
Encroachment removal and relocation	Framing and implementation of slum rehabilitation plan to rehabilitate displaced families due to encroachment removal and land rehabilitation
Multiplicity of agencies associated with permissions, ownership of water channels/bodies	Generation of funds required through a combination of routine budgetary allocation, enhanced revenue through financial reforms, special levy for SWD improvement and additional grants from State/Central government
Shifting of utilities	
Lack of funding sources (projected cost is around 3 billion USD)	

4.5 Flood modelling and analysis

The data generated in **Paper VI** were used in the MIKE runoff model to describe the flooding situation in Mumbai and the flood maps were compared with two available sources (Fact Finding Committee 2005 Floods) and areas designated as flood prone by (Municipal Corporation of Greater Mumbai, 2005) in a 2005 report (Figure 9), **Paper VIII**. It was concluded that most of the areas, which have been flooded historically, were also simulated as flooded in the modelling results. Further, it was noted that the model predicted some areas with flooding more than 1m where flooding was not reported by the Fact Finding Committee 2005 Flood. One reason for such difference is related to the resolution of data used in the model. The source DEM data (finer resolution than 30 m is missing) used for modelling were s rough and only

for bare ground, information about the urban infrastructures is missing which could provide better information on flooding. This is preventing accurate reproduction of the flow through the city. Moreover the model showed less extended flood in some areas as the 290 mm scenario included less rain than the one observed during the 2005 flood event. However, no drainage network influence was included in the model, since such information was not available. Consequently, the model is also expected to overestimate the flood to a certain extent, as a small part of the rain will be drainage, before surface flooding begins.

Figure 9 represents the maximum water depth attained in the study area for different rainfall scenario simulations. Red colour in the figure signifies maximum water depth above 1 m in the study area after 1 day of model run. It can be easily observed that there is flooding in each and every part of the city. It was also visually observed by the authors by a site visit and using Google Earth, that there are very few infiltration surfaces in the city and the poor natural drainage of the city does not help water to discharge. The natural topography and location of the area do not help to evacuate the surface runoff (flat area by the sea, outlet of a river, reclaimed land, and swamp, whatever natural cause that made the area of Mumbai a natural floodplain).

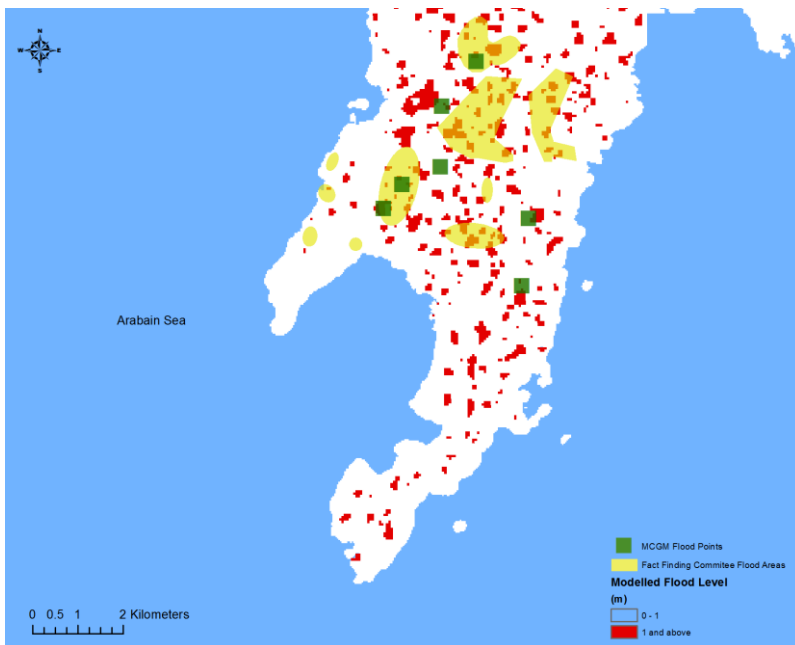

Figure 9: Comparative flood map of the study area with modelled flooded areas and those presented in earlier studies (adopted from **Paper VIII**).

5 DISCUSSION AND CONCLUDING REMARKS

5.1 Mumbai, India

It is evident from the above analysis of drainage systems that the infrastructure for the city of Mumbai is not able to cope with high-intensive rainfall. Clearly, the storm water system has inadequate capacity along with many other problems. Flood simulations for Mumbai also suggested that many areas are under constant threat during the monsoon season. The main problems in the Mumbai drainage system are clogging from solid waste, authorities with overlapping responsibilities, low level of awareness among citizens, and relocation of slum areas. The work for flood resilience and work against poverty must go hand in hand, as the areas along the open storm-water system (creeks and rivers) are needed as floodable land. These areas are today slum areas where people are in great need for better housing. Mumbai is struggling with severe flooding every monsoon season. There is huge loss of life and property due to floods. Large areas are under heavy stress, and the situation is especially hard to solve due to high population density and lack of land resources. The municipal corporation in Mumbai is working on all aspects of flood prevention and control, but economic instability is a huge drawback. Authorities are working mainly with flood forecasting and management systems, emergency response, de-silting of main drains before monsoon season, and redevelopment of drainage system according to the increased capacity along with education for awareness.

Measures of flood prevention, safe disposal of waste, and wastewater handling in slums must be addressed to cope with the increasing stress on resources. Some studies suggest that by the 2080s assuming a climate change scenario could mean the doubled probability for a 2005-like event. The estimated total losses (direct plus indirect) associated with a 1-in-100 year event could triple compared to the current situation (to \$690 – \$1890 million USD) (Hallegatte et al., 2010). Estimates have also suggested that improvement in the drainage system can reduce the losses of 100-year return period flood by almost 70%. Moreover, the variability of trends in precipitation that are observed at Mumbai also presents a challenging task for the management. A significant negative change for long-term rainfall was detected for different seasons and for the whole year in the 1951–2004 period. Trends in southwest monsoon precipitation for Mumbai were related to the variability of climatic indices that is oscillating on decadal or longer basis.

When comparing the future trends of precipitation over Mumbai using GCM output, it is interesting to note the significant positive trends shown by most of the models in different projections. Different models suggest different trends during the periods analysed including a positive trend in long-term projection where 2010-99 data is analysed. This calls for attention of planners and managers to make suitable adjustment in the collection and drainage system of Mumbai keeping in mind future projections in the area. It should be noted that while the projections presented in this study are indicative of the expected range of rainfall changes, the quantitative estimates still have uncertainties associated with them. The uncertainties associated may also be because of inability of DBS method to perfectly resolve bias with the onset

of monsoon season in the study area and high rainfall in September month. Improvements are still required in climate model post-processing methodologies to deal with substantial biases, e.g., related to inaccurate timing and location of stationary synoptic-scale rainfall fields such as the monsoon, which are then studied in different paper.

Comparison of modelled flood areas with the observations sheds light on the key aspects of flood modelling in the area including need for need and information for such a study. The maps presented in earlier studies are not providing information on key criteria's; such as spatial and temporal extent, flooding depth etc.; that can be compared with the present model. The presented model is able to cover all the areas (spatially) as presented/observed by other studies but the extent of flooding is less than the observations owing to lack of information and bare DEM without any urban infrastructure. The water depth in all the simulations under consideration is reaching height of more than 1m in each case and goes up to 6m of water for the most severe rainfall event. . The IDF curves derived for Mumbai indicates that the present design standard values are very low. The design is for a storm with less than annual return period. Thus, flooding is expected to occur several times in a year, which in fact also happens. Infrastructural planning of urban area should require careful attention to urban drainage characteristics. This high intensity/frequency of precipitation is alarming and main problem for Mumbai.

5.2 Southern Sweden and Gothenburg

Based on the present thesis results, it is clear that the annual precipitation has increased in southern Sweden. Univariate and multivariate analysis helped in pointing out trends and extreme events. The increase in precipitation was about 20%. The increase is attributed to increased winter precipitation. For most of the stations, the trend is the strongest after 1960. The winter precipitation in southern Sweden has increased much over the last 100+ years, which has resulted in more frequent daily and multi-daily storms shorter than 1 year return period. The extreme storms with long return periods have not changed.

A way of testing models is to compare their performance over time along with feasibility of the statistical methods for bias correction. PCA analysis on monthly precipitation data revealed that RCM-PROMES simulations lie in the same phase as the observed series, whereas, all other model simulations were found to lie in different phase. Mann Kendall test showed no significant trend in monthly precipitation over the years neither for observed nor model simulations. The observed data, RCM-PROMES, and CLM give similar parameter estimates of location, scale and shape parameters of the GEV-distribution and all estimated a return level of 40 mm every 10 years. Also, moderately large events as determined from the models could not be rejected for the Poisson distribution hypothesis except for RCM-HadRM3Qo. PROMES in accordance with the historic data predicts 4-5 events exceeding 20 mm in a year. Simulated annual precipitation autocorrelation agreed with autocorrelation for corresponding observed data.

In urban areas, it is very important to study the effects of urban conditions on rainfall-runoff relationships. Changes in the physical characteristics of urban areas change the runoff response of the area along with climatic effects. Thus, it is necessary

to evaluate the effects of changes in precipitation and human interference on the natural drainage patterns of the urban area. Gothenburg city wants to cope with climate change by being restrictive in building in low-lying areas, but the low-lying areas are close to the city centre and attractive for building. Important buildings and constructions in the city centre are at risk of flooding when the sea level rises. Thus, it appears the Gothenburg is more heading for flood resistance, building high floodwalls to prevent from flooding with a certain return period, instead of building a flood resilient city, with floodable areas in strategic places.

5.3 Disaggregation of Rainfall

In most cities there is a need of information about short-term rains for design of infrastructure. It was found that rainfall disaggregation could be used to derive short-term rain information for tropical rains with about 30 min resolution when only daily data are available. It can help in providing fine time scale precipitation data necessary for many engineering and environmental applications. It should be emphasized that this is intended as a real-world demonstration case with limited possibilities for proper validation and uncertainty assessment.

The multiplicative cascade based model for disaggregation of rainfall was found to be useful in the study area. For shorter time steps good agreement between model results and observations was found, when the parameters were allowed to vary with scale according to simple linear functions. The cascade weights' volume dependence was found to be significant. Although, the parameters were related to time scale, the maximum values were overestimated for time scales less than about 30 min.

Even though the fitted model seemed to overall reasonably well reproduce key statistics over the whole range of time scales considered, distinct deviations were found and further no cross-validation was attainable. Clearly the deviations can partly be attributed to imprecise parameter estimates from the limited amount of short-term data available, but also the model structure and scale-dependent relationships are likely not strictly following by the rainfall data. More in-depth analyses of the impact of high-resolution data availability on parameter estimation and model performance are clearly needed.

5.4 Outlook and Future Work

The present work can help achieve sustainable solutions for the city of Mumbai and can serve as a guideline for many other urban centres across the world dealing with similar problems. Although there are uncertainties about the magnitude and direction of future climate variations at various locations, measures must be initiated to minimize the adverse impacts of these changes on society and resources for a sustainable future. Trend relationships may prove useful in prediction of rainfall for these urban centres to improve planning and management. Finally, there is a need to incorporate climate variability in the planning and management of water resources of large urban centers. This study provides methods for sensitivity analysis of water management in the study area.

A recommendation, for both cities, is to develop the storm water systems further with sustainability and resilience perspectives in mind, including building flood plain areas

close to the city centre. We are concerned about the high risk for lives in Mumbai, and the willingness in Gothenburg to build in low-lying areas. The problems in Mumbai are more extensive because of the insufficient storm water system and the climatic conditions as the population density is very high. In Gothenburg, the low frequency of floods today might be a problem when it comes to local awareness. The flood risk of tomorrow seems to have been forgotten in the overall city development planning. In this perspective, building of a resilient system might be easier in Mumbai, as the annual monsoon season is a good reminder of the importance of good storm water management. It is important to educate leaders and practitioners in both cities about resilience and sustainability perspectives.

The projections can be used in management and planning of the city and formulating the policies accordingly. Planners now have a handy analysis of future projections for decision making, based on level of performance or acceptable level of risk, of the infrastructure system desired for. There are indeed developments in studying the impact of climate change on regional scale but options need to be explored further for reduction of uncertainties with GCM data and scaling procedures. Results of the present study should be seen as an improvement to impact studies, using scaling methodology on regional scale involving GCM projections. In urban areas, it is very important to study the effects of extreme events and increase in net rainfall and rainfall–runoff relationships. Changes in the physical characteristics of urban areas change the runoff response of the area along with climatic forces. Thus, it is necessary to evaluate the effect of changes in rainfall and human interference on the natural drainage patterns of the urban area. Infrastructural planning of urban areas requires careful attention to urban drainage characteristics. This study could be useful for adaptation studies in future for the study area.

Given the potential implications of regional climate changes towards documenting national policies, and building infrastructure that meets climate related extreme events such as droughts, floods, and hurricanes one needs to study how reliable projections are given by RCMs of future change. One can conclude that regional climate models are able to capture the character of daily precipitation on a rather local scale but there is a need to realize the bias correction methods used for impact studies. The presented statistical methods can be used for correcting raw RCM data in accordance to observed values. The improved RCM data can then be thoroughly used for impact studies. Among the five regional climate models considered, the RCM-PROMES simulation statistics were able to best define the patterns and occurrence of events. Results also indicate that although there are conceptual problems and practical limitations in using these high-resolution climate model output for predicting ecosystem responses, the mean statistics were well which should be sufficient for most ecosystem problems.

Future research should be concentrated on finding sustainable solution for the cities in consideration along with detailed emergency response system. Future projections for southern Sweden either using GCM or RCM projections along with Gothenburg form the next follow up research.

6 REFERENCES

- Annamalai, H., Hamilton, K., Sperber, K.R., 2007. The South Asian Summer Monsoon and Its Relationship with ENSO in the IPCC AR4 Simulations. *J. Clim.*, 20(6): 1071-1092.
- Appleton, B. (Ed.), 2002. *Climate Changes the Water Rules*, Dialogue on Water and Climate. Printfine Ltd., Liverpool, UK.
- Ashley, R.M., Balmforth, D.J., Saul, A.J., Blanskby, J.D., 2005. Flooding in the future - predicting climate change, risks and responses in urban areas. *Water Sci. Technol.*, 52(5): 265-273.
- Balmforth D., D.C.J., Butler D., Shaffer P., 2006. *Integrated Urban Drainage Pilots: Scoping Study*, DEFRA, London.
- Bergstrom, S., 2001. Climate change impacts on runoff in Sweden-assessments by global climate models, dynamical downscaling and hydrological modelling. *Clim. Res.*, 16(2): 101.
- Bo, Z.Q., Islam, S., Eltahir, E.A.B., 1994. Aggregation-Disaggregation Properties of a Stochastic Rainfall Model. *Water Resour Res*, 30(12): 3423-3435.
- Bretherton, C.S., Smith, C., Wallace, J.M., 1992. An Intercomparison of Methods for Finding Coupled Patterns in Climate Data. *J. Clim.*, 5(6): 541-560.
- Busuioc, A., Chen, D., Hellström, C., 2011. Temporal and spatial variability of precipitation in Sweden and its link with the large-scale atmospheric circulation, 53.
- Chen, H., Xu, C.-Y., Guo, S., 2012. Comparison and evaluation of multiple GCMs, statistical downscaling and hydrological models in the study of climate change impacts on runoff. *J. Hydrol.*, 434-435(0): 36-45.
- Cheng, X.T.a.Q., J.W., 2001. Development of Urban Flood Simulation Techniques in China. In: Theme C, Forecasting and Mitigation of Water-Related Disasters, XXIX International Association of Hydraulic Research Congress Proceedings. Tsinghua University Press, pp. 393-402.
- Chow, V.T.a.B., A.Z., 1973. Hydrodynamic Modeling of Two- Dimensional Watershed Flow. *Journal of Hydraulics Division. ASCE*, 99(11): 2023-2040.
- Coates, L., 1999. Flood fatalities in Australia, 1788-1996. *Aust. Geogr.*, 30(3): 391-408.
- Connolly, R.D., Schirmer, J., Dunn, P.K., 1998. A daily rainfall disaggregation model. *Agricultural and Forest Meteorology*, 92(2): 105-117.
- Cowpertwait, P.S.P., O'Connell, P.E., Metcalfe, A.V., Mawdsley, J.A., 1996. Stochastic point process modelling of rainfall. II. Regionalisation and disaggregation. *J. Hydrol.*, 175(1-4): 47-65.

References

- Dahlström, B., 1979. Regional fördelning av nederbördsintensitet – en klimatologisk analys (Regional distribution of storm intensities – a climatological analysis). Byggnadsforskningen, R18:1979(83).
- Dahlström, B., 2006. Regnintensitet i Sverige – en klimatologisk analys (Storm intensities in Sweden - a climatological analysis). VA-Forsk rapport Nr 2006-26, 69s.
- Dash, S.K., Kulkarni, M.A., Mohanty, U.C., Prasad, K., 2009. Changes in the characteristics of rain events in India. *Journal of Geophysical Research: Atmospheres*, 114(D10): D10109.
- De, U., Dandekar, M., 2001. Natural Disasters in Urban areas. *Deccan Geographer*, 39: 1-12.
- Denault, C., Millar, R.G., Lence, B.J., 2006. ASSESSMENT OF POSSIBLE IMPACTS OF CLIMATE CHANGE IN AN URBAN CATCHMENT1. *JAWRA Journal of the American Water Resources Association*, 42(3): 685-697.
- Deshpande, N.R., Kulkarni, A., Krishna Kumar, K., 2012. Characteristic features of hourly rainfall in India. *International Journal of Climatology*, 32(11): 1730-1744.
- Djokic, D., Maidment, D.R., 1991. Terrain analysis for urban stormwater modelling. *Hydrol Process*, 5(1): 115-124.
- Djordjevic, S., Prodanovic, D., Maksimovic, C., 1999. An approach to simulation of dual drainage. *Water Sci. Technol.*, 39(9): 95-103.
- Dore, M.H.I., 2005. Climate change and changes in global precipitation patterns: What do we know? *Environ Int*, 31(8): 1167-1181.
- Durman, C.F., Gregory, J.M., Hassell, D.C., Jones, R.G., Murphy, J.M., 2001. A comparison of extreme European daily precipitation simulated by a global and a regional climate model for present and future climates. *Quarterly Journal of the Royal Meteorological Society*, 127(573): 1005-1015.
- Econopouly, T.W., Davis, D.R., Woolhiser, D.A., 1990. Parameter transferability for a daily rainfall disaggregation model. *J. Hydrol.*, 118(1-4): 209-228.
- Elliott, A.H., Trowsdale, S.A., 2007. A review of models for low impact urban stormwater drainage. *Environmental Modelling & Software*, 22(3): 394-405.
- Emanuel, W.R., Shugart, H.H., Stevenson, M.P., 1985. Climatic change and the broad-scale distribution of terrestrial ecosystem complexes. *Clim. Change*, 7(1): 29-43.
- Espey, W.H., Jr., C.W. Morgan, and F.D. Masch., 1966. A Study of Some Effects of Urbanization on Storm Runoff From a Small Watershed. Report No. 3, Texas Water Development Board, Austin, Texas.
- Fan, F., Mann, M.E., Lee, S., Evans, J.L., 2010. Observed and Modeled Changes in the South Asian Summer Monsoon over the Historical Period*. *J. Clim.*, 23(19): 5193-5205.
- Fowler, H.J., Blenkinsop, S., Tebaldi, C., 2007. Linking climate change modelling to impacts studies: recent advances in downscaling techniques for hydrological modelling. *International Journal of Climatology*, 27(12): 1547-1578.

References

- Frei, C., Schär, C., Lüthi, D., Davies, H.C., 1998. Heavy precipitation processes in a warmer climate. *Geophys. Res. Lett.*, 25(9): 1431-1434.
- Frei, C., Schöll, R., Fukutome, S., Schmidli, J., Vidale, P.L., 2006. Future change of precipitation extremes in Europe: Intercomparison of scenarios from regional climate models. *J. Geophys. Res.*, 111(D6): D06105.
- French, J., Ing. R., von Allmen, S., and Wood, R., 1983. Mortality from flash floods: A review of the national weather service reports, 1969–1981. *Public Health Rep.*, 98(6): 584-588.
- Gadgil, A., Dhorde, A., 2005. Temperature trends in twentieth century at Pune, India. *Atmos. Environ.*, 39(35): 6550-6556.
- Gaume, E., Mouhous, N., Andrieu, H., 2007. Rainfall stochastic disaggregation models: Calibration and validation of a multiplicative cascade model. *Adv Water Resour.* 30(5): 1301-1319.
- Glasbey, C.A., Cooper, G., McGechan, M.B., 1995. Disaggregation of daily rainfall by conditional simulation from a point-process model. *J. Hydrol.*, 165(1-4): 1-9.
- Goswami, B.N., Venugopal, V., Sengupta, D., Madhusoodanan, M.S., Xavier, P.K., 2006. Increasing Trend of Extreme Rain Events Over India in a Warming Environment. *Science*, 314(5804): 1442-1445.
- Grum, M., Jorgensen, A.T., Johansen, R.M., Linde, J.J., 2006. The effect of climate change on urban drainage: an evaluation based on regional climates model simulations. *Water Sci. Technol.*, 54(6-7): 9-15.
- Güntner, A., Olsson, J., Calver, A., Gannon, B., 2001. Cascade-based disaggregation of continuous rainfall time series: the influence of climate. *Hydrol. Earth Syst. Sci.*, 5(2): 145-164.
- Guo, Y., 2006a. Updating Rainfall IDF Relationships to Maintain Urban Drainage Design Standards. *Journal of Hydrologic Engineering*, 11(5): 506-509.
- Guo, Y.P., 2006b. Updating rainfall IDF relationships to maintain urban drainage design standards. *Journal of Hydrologic Engineering*, 11(5): 506-509.
- Hajat, S. et al., 2005. The Human Health Consequences of Flooding in Europe: a Review. In: Kirch, W., Bertollini, R., Menne, B. (Eds.), *Extreme Weather Events and Public Health Responses*. Springer Berlin Heidelberg, pp. 185-196.
- Hall, J., Meadowcroft, I., Sayers, P., Bramley, M., 2003. Integrated Flood Risk Management in England and Wales. *Natural Hazards Review*, 4(3): 126-135.
- Hallegatte, S. et al., 2010. Flood Risks, Climate Change Impacts and Adaptation Benefits in Mumbai.
- Harris, D., Menabde, M., Seed, A., Austin, G., 1996. Multifractal characterization of rain fields with a strong orographic influence. *J. Geophys. Res.-Atmos.*, 101(D21): 26405-26414.

References

- Haugen, J.E., Iversen, T., 2008. Response in extremes of daily precipitation and wind from a downscaled multi-model ensemble of anthropogenic global climate change scenarios. *Tellus A*, 60(3): 411-426.
- Haylock, M.R. et al., 2006. Trends in total and extreme South American rainfall in 1960-2000 and links with sea surface temperature. *J. Clim.*, 19(8): 1490-1512.
- Heaney J.P., S.D., Wright L., 2001. Geographical Information Systems, Decision Support Systems, and Urban Management, US Environmental Protection Agency.
- Hennessy, K.J., Gregory, J.M., Mitchell, J.F.B., 1997. Changes in daily precipitation under enhanced greenhouse conditions. *Climate Dynamics*, 13(9): 667-680.
- Hershendorff, J., Woolhiser, D.A., 1987. Disaggregation of daily rainfall. *J. Hydrol.*, 95(3-4): 299-322.
- Hsu, M.H., Chen, S.H., Chang, T.J., 2000. Inundation simulation for urban drainage basin with storm sewer system. *J. Hydrol.*, 234(1-2): 21-37.
- Hubert, P. et al., 1993. Multifractals and Extreme Rainfall Events. *Geophys. Res. Lett.*, 20(10): 931-934.
- Hundecha, Y., Bárdossy, A., 2005. Trends in daily precipitation and temperature extremes across western Germany in the second half of the 20th Century. *International Journal of Climatology*, 25(9): 1189-1202.
- Huntingford, C., Hugo Lambert, F., Gash, J.H.C., Taylor, C.M., Challinor, A.J., 2005. Aspects of climate change prediction relevant to crop productivity. *Philosophical Transactions of the Royal Society B: Biological Sciences*, 360(1463): 1999-2009.
- Huntington, T.G., 2006. Evidence for intensification of the global water cycle: Review and synthesis. *J. Hydrol.*, 319(1-4): 83-95.
- Iwasa, Y.a.K.I., 1980. Numerical Method for Inundating Flood, Annuals of Disasters Prevention Research Institute of Kyoto University, No.23, B-2, Kyoto, Japan.
- Jebari, S., Berndtsson, R., Olsson, J., Bahri, A., 2012. Soil erosion estimation based on rainfall disaggregation. *J. Hydrol.*, 436-437(0): 102-110.
- Jha, A.K., Akiyama, J., Ura, M., 2000. Flux-difference splitting schemes for 2D flood flows. *J Hydraul Eng-Asce*, 126(1): 33-42.
- Jones, R.G., Murphy, J.M., Noguer, M., Keen, A.B., 1997. Simulation of climate change over Europe using a nested regional-climate model. II: Comparison of driving and regional model responses to a doubling of carbon dioxide. *Quarterly Journal of the Royal Meteorological Society*, 123(538): 265-292.
- Kao, S.-C., Ganguly, A.R., 2011. Intensity, duration, and frequency of precipitation extremes under 21st-century warming scenarios. *J. Geophys. Res.*, 116(D16): D16119.
- Katopodes, N., Strelkoff, T., 1997. Computing two-dimensional dam-break flood waves (vol 104, pg 1267, 1978). *J Hydraul Eng-Asce*, 123(10): 938-938.
- Kay, A.L., Reynard, N.S., Jones, R.G., 2006. RCM rainfall for UK flood frequency estimation. I. Method and validation. *J. Hydrol.*, 318(1-4): 151-162.

References

- Kharin, V.V., Zwiers, F.W., 2000. Changes in the extremes in an ensemble of transient climate simulations with a coupled atmosphere-ocean GCM. *J. Clim.*, 13(21): 3760-3788.
- Kharin, V.V., Zwiers, F.W., Zhang, X., Hegerl, G.C., 2007. Changes in Temperature and Precipitation Extremes in the IPCC Ensemble of Global Coupled Model Simulations. *J. Clim.*, 20(8): 1419-1444.
- Kotlarski, S., 2005. Regional climate model simulations as input for hydrological applications: evaluation of uncertainties. *Advances in geosciences*, 5: 119.
- Kripalani, R.H., Kulkarni, A., Sabade, S.S., Khandekar, M.L., 2003. Indian Monsoon Variability in a Global Warming Scenario. *Nat. Hazards*, 29(2): 189-206.
- Kripalani, R.H., Oh, J.H., Kulkarni, A., Sabade, S.S., Chaudhari, H.S., 2007. South Asian summer monsoon precipitation variability: Coupled climate model simulations and projections under IPCC AR4. *Theor. Appl. Climatol.*, 90(3-4): 133-159.
- Krishnan, R. et al., 2013. Will the South Asian monsoon overturning circulation stabilize any further? *Climate Dynamics*, 40(1-2): 187-211.
- Kumar, J.R., Dash, S.K., 2001. Interdecadal variations of characteristics of monsoon disturbances and their epochal relationships with rainfall and other tropical features. *International Journal of Climatology*, 21(6): 759-771.
- Kumar, K.K. et al., 2011. The once and future pulse of Indian monsoonal climate. *Climate Dynamics*, 36(11-12): 2159-2170.
- Kumke, T., 2001. Book Review: *Regional Frequency Analysis: An Approach Based on L-Moments* By J. R. M. Hosking and J. R. Wallis Cambridge University Press, Cambridge, UK, 1997, 224 p., \$69.95 (U.S.), ISBN 0-521-43045-3 hardback. *Mathematical Geology*, 33(4): 535-537.
- Kutzbach, J.E., 1967. Empirical Eigenvectors of Sea-Level Pressure, Surface Temperature and Precipitation Complexes over North America. *Journal of Applied Meteorology*, 6(5): 791-802.
- Lal, M., Meehl, G.A., Arblaster, J.M., 2000. Simulation of Indian summer monsoon rainfall and its intraseasonal variability in the NCAR climate system model. *Reg Environ Change*, 1(3-4): 163-179.
- Langousis, A., Veneziano, D., 2007. Intensity-duration-frequency curves from scaling representations of rainfall. *Water Resour Res*, 43(2): -.
- Licznar, P., Lomotoski, J., Rupp, D.E., 2011. Random cascade driven rainfall disaggregation for urban hydrology: An evaluation of six models and a new generator. *Atmos. Res.*, 99(3-4): 563-578.
- Madsen, H., Arnbjerg-Nielsen, K., Mikkelsen, P.S., 2009. Update of regional intensity-duration-frequency curves in Denmark: Tendency towards increased storm intensities. *Atmos. Res.*, 92(3): 343-349.

References

- Mailhot, A., Duchesne, S., Caya, D., Talbot, G., 2007. Assessment of future change in intensity-duration-frequency (IDF) curves for Southern Quebec using the Canadian Regional Climate Model (CRCM). *J. Hydrol.*, 347(1-2): 197-210.
- Majumdar, K.C., Sawhney, R.P., 1965. Estimates of extreme values by different distribution functions. *Water Resour Res*, 1(3): 429-434.
- Makropoulos, C., Butler, D., Maksimovic, C., 2001. Gis-supported stormwater source control implementation and urban flood risk mitigation. *Advances in Urban Stormwater and Agricultural Runoff Source Controls*, 6: 95-105.
- Maraun, D., Osborn, T.J., Gillett, N.P., 2008. United Kingdom daily precipitation intensity: improved early data, error estimates and an update from 2000 to 2006. *International Journal of Climatology*, 28(6): 833-842.
- Maraun, D. et al., 2010. Precipitation downscaling under climate change: Recent developments to bridge the gap between dynamical models and the end user. *Rev. Geophys.*, 48(3): RG3003.
- Mark, O., Weesakul, S., Apirumanekul, C., Aroonnet, S.B., Djordjevic, S., 2004. Potential and limitations of 1D modelling of urban flooding. *J. Hydrol.*, 299(3-4): 284-299.
- May, W., 2002. Simulated changes of the Indian summer monsoon under enhanced greenhouse gas conditions in a global time-slice experiment. *Geophys. Res. Lett.*, 29(7): 22-1-22-4.
- May, W., 2004. Simulation of the variability and extremes of daily rainfall during the Indian summer monsoon for present and future times in a global time-slice experiment. *Climate Dynamics*, 22(2-3): 183-204.
- May, W., 2011. The sensitivity of the Indian summer monsoon to a global warming of 2°C with respect to pre-industrial times. *Climate Dynamics*, 37(9-10): 1843-1868.
- McGuffie, K. et al., 1999. Assessing simulations of daily temperature and precipitation variability with global climate models for present and enhanced greenhouse climates. *International Journal of Climatology*, 19(1): 1-26.
- McKibben, B., 2007. *Climate change 2007: The physical science basis: Summary for policymakers* (vol 54, pg 44, 2007). *New York Rev Books*, 54(8): 58-58.
- Meehl, G.A., Arblaster, J.M., 2003. Mechanisms for projected future changes in south Asian monsoon precipitation. *Climate Dynamics*, 21(7-8): 659-675.
- Menabde, M., Sivapalan, M., 2000. Modeling of rainfall time series and extremes using bounded random cascades and levy-stable distributions. *Water Resour. Res.*, 36(11): 3293-3300.
- Mitchell, J.M.J. et al., 1966. *Climate Change*, World Meteorological Organisation, Geneva, Switzerland.
- Moberg, A. et al., 2006. Indices for daily temperature and precipitation extremes in Europe analyzed for the period 1901–2000. *Journal of Geophysical Research: Atmospheres*, 111(D22): D22106.

References

- Molnar, P., Burlando, P., 2005. Preservation of rainfall properties in stochastic disaggregation by a simple random cascade model. *Atmos. Res.*, 77(1-4): 137-151.
- Mooney, L.E., 1983. Applications and implications of fatality statistics to the flash flood problems, Proceedings of the 5th Conference on Hydrometeorology, Tulsa, USA.
- Municipal Corporation of Greater Mumbai, 2005. Greater Mumbai City Development Plan (2005 to 2025). Municipal Corporation of Greater Mumbai, Mumbai.
- Naidu, C.V., Rao, B.R.S., Rao, D.V.B., 1999. Climatic trends and periodicities of annual rainfall over India. *Meteorol. Appl.*, 6(4): 395-404.
- Niemczynowicz, J., 1989. Impact of the Greenhouse-Effect on Sewerage Systems - Lund Case-Study. *Hydrolog Sci J*, 34(6): 651-666.
- Niemczynowicz, J., 1999. Urban hydrology and water management - present and future challenges. *Urban Water*, 1(1): 1-14.
- OFDA/CRED, 2013. OFDA/CRED International Disaster Database.
- Olsson, J., 1995. Limits and characteristics of the multifractal behaviour of a high-resolution rainfall time series. *Nonlin. Processes Geophys.*, 2(1): 23-29.
- Olsson, J., 1998. Evaluation of a scaling cascade model for temporal rain- fall disaggregation. *Hydrol. Earth Syst. Sci.*, 2(1): 19-30.
- Osborn, T.J., Hulme, M., Jones, P.D., Basnett, T.A., 2000. Observed trends in the daily intensity of United Kingdom precipitation. *International Journal of Climatology*, 20(4): 347-364.
- Over, T.M., Gupta, V.K., 1994. Statistical Analysis of Mesoscale Rainfall: Dependence of a Random Cascade Generator on Large-Scale Forcing. *Journal of Applied Meteorology*, 33(12): 1526-1542.
- Pagliara, S., Viti, C., Gozzini, B., Meneguzzo, F., Crisci, A., 1998. Uncertainties and trends in extreme rainfall series in Tuscany, Italy: Effects on urban drainage networks design. *Water Sci. Technol.*, 37(11): 195-202.
- Parker, D., 1980. Floods - a Geographical Perspective - Ward,R. *Geography*, 65(287): 156-156.
- Parry, M., 1989. The Impact of Climatic Variations on Agriculture. *Bulletin of the American Academy of Arts and Sciences*, 42(8): 30-36.
- Parthasarathy, B., Kumar, K.R., Munot, A.A., 1993. HOMOGENEOUS INDIAN MONSOON RAINFALL - VARIABILITY AND PREDICTION. *Proc. Indian Acad. Sci.-Earth Planet. Sci*, 102(1): 121-155.
- Pinto, J.G., Neuhaus, C.P., Leckebusch, G.C., Reyers, M., Kerschgens, M., 2010. Estimation of wind storm impacts over Western Germany under future climate conditions using a statistical-dynamical downscaling approach. *Tellus A*, 62(2): 188-201.
- Prohaska, J.T., 1976. A Technique for Analyzing the Linear Relationships between Two Meteorological Fields. *Mon. Weather Rev.*, 104(11): 1345-1353.

References

- Raisanen, J., Joellsson, R., 2001. Changes in average and extreme precipitation in two regional climate model experiments. *Tellus A*, 53(5): 547-566.
- Ramesh Kumar, M.R., Krishnan, R., Sankar, S., Unnikrishnan, A.S., Pai, D.S., 2009. Increasing Trend of Break-Monsoon Conditions Over India; Role of Ocean-Atmosphere Processes in the Indian Ocean. *Geoscience and Remote Sensing Letters, IEEE*, 6(2): 332-336.
- Roberson, J.A., J.J. Cassidy, and M.H. Chaudhry, 1998. *Hydraulic Engineering* (2nd edition). John Wiley and Sons, Inc., New York.
- Rotmans, J., Hulme, M., Downing, T.E., 1994. Climate change implications for Europe: An application of the ESCAPE model. *Global Environmental Change*, 4(2): 97-124.
- Rupakumar K, S.A., Krishna Kumar K, Patwardhan SK, Mishra PK, Revadekar JV, Kamala K, Pant GB., 2006. High-resolution climate change scenarios for India for the 21st century. *Current Science*, 90: 334-345.
- Rupakumar, K. et al., 2006. High-resolution climate change scenarios for India for the 21st century. *Curr. Sci.*, 90: 334-345.
- Rupp, D.E., Keim, R.F., Ossiander, M., Brugnach, M., Selker, J.S., 2009. Time scale and intensity dependency in multiplicative cascades for temporal rainfall disaggregation. *Water Resour. Res.*, 45(7): W07409.
- Sabade, S.S., Kulkarni, A., Kripalani, R.H., 2011. Projected changes in South Asian summer monsoon by multi-model global warming experiments. *Theor. Appl. Climatol.*, 103(3-4): 543-565.
- Schertzer, D., Lovejoy, S., 1987. Physical Modeling and Analysis of Rain and Clouds by Anisotropic Scaling Multiplicative Processes. *J. Geophys. Res.-Atmos.*, 92(D8): 9693-9714.
- Schmidli, J., Frei, C., 2005. Trends of heavy precipitation and wet and dry spells in Switzerland during the 20th Century. *International Journal of Climatology*, 25(6): 753-771.
- Schmitt, T.G., Thomas, M., Ettrich, N., 2004. Analysis and modeling of flooding in urban drainage systems. *J. Hydrol.*, 299(3-4): 300-311.
- Schoof, J.T. et al., 2009. Dynamically and statistically downscaled seasonal temperature and precipitation hindcast ensembles for the southeastern USA. *International Journal of Climatology*, 29(2): 243-257.
- Semadeni-Davies, A., 2004. Urban Water Management vs. Climate Change: Impacts on Cold Region Waste Water Inflows. *Clim. Change*, 64(1): 103-126.
- Semenov, V.S., Bengtsson, L.B., 2002. Secular trends in daily precipitation characteristics: greenhouse gas simulation with a coupled AOGCM. *Climate Dynamics*, 19(2): 123-140.
- Semmler, T., Jacob, D., 2004. Modeling extreme precipitation events—a climate change simulation for Europe. *Global and Planetary Change*, 44(1-4): 119-127.

References

- Sen Roy, S., 2006. The impacts of ENSO, PDO, and local SSTs on winter precipitation in India. *Phys. Geogr.*, 27(5): 464-474.
- Singh, N., Sontakke, N.A., 1999. On the variability and prediction of rainfall in the post-monsoon season over India. *International Journal of Climatology*, 19(3): 309-339.
- Singh, O.P., 2001. Multivariate ENSO index and Indian monsoon rainfall: relationships on monthly and subdivisional scales. *Meteorol. Atmos. Phys.*, 78(1-2): 1-9.
- Skaugen, T., Alfnes, E., Langsholt, E.G., Udn, s, H.-C., 2004. Time-variant snow distribution for use in hydrological models. *Annals of Glaciology*, 38(1): 180-186.
- Smith, J., Pitts, G., 1997. REGIONAL CLIMATE CHANGE SCENARIOS FOR VULNERABILITY AND ADAPTATION ASSESSMENTS. *Clim. Change*, 36(1): 3-21.
- Smithson, P.A., 2002. IPCC, 2001: climate change 2001: the scientific basis. Contribution of Working Group 1 to the Third Assessment Report of the Intergovernmental Panel on Climate Change, edited by J. T. Houghton, Y. Ding, D. J. Griggs, M. Noguer, P. J. van der Linden, X. Dai, K. Maskell and C. A. Johnson (eds). Cambridge University Press, Cambridge, UK, and New York, USA, 2001. No. of pages: 881. Price £34.95, US\$ 49.95, ISBN 0-521-01495-6 (paperback). £90.00, US\$ 130.00, ISBN 0-521-80767-0 (hardback). *International Journal of Climatology*, 22(9): 1144-1144.
- Stowasser, M., Annamalai, H., Hafner, J., 2009. Response of the South Asian Summer Monsoon to Global Warming: Mean and Synoptic Systems*. *J. Clim.*, 22(4): 1014-1036.
- Svensson, C., Olsson, J., Berndtsson, R., 1996. Multifractal properties of daily rainfall in two different climates. *Water Resour Res*, 32(8): 2463-2472.
- Tessier, Y., Lovejoy, S., Schertzer, D., 1993. Universal multifractals: Theory and observations for rain and clouds. *Journal Name: Journal of Applied Meteorology; (United States); Journal Volume: 32:2: Medium: X; Size: Pages: 223-250.*
- Teutschbein, C., Wetterhall, F., Seibert, J., 2011. Evaluation of different downscaling techniques for hydrological climate-change impact studies at the catchment scale. *Climate Dynamics*, 37(9): 2087-2105.
- Thornes, J.E., 2002. IPCC, 2001: Climate change 2001: impacts, adaptation and vulnerability, Contribution of Working Group II to the Third Assessment Report of the Intergovernmental Panel on Climate Change, edited by J. J. McCarthy, O. F. Canziani, N. A. Leary, D. J. Dokken and K. S. White (eds). Cambridge University Press, Cambridge, UK, and New York, USA, 2001. No. of pages: 1032. Price: £34.95, ISBN 0-521-01500-6 (paperback), ISBN 0-521-80768-9 (hardback). *International Journal of Climatology*, 22(10): 1285-1286.
- Toda K., K.I., K. Kuriyama, and O. Maeda, 2001. Inundation Flow Analysis in Urban Areas Considering Streets and Underground Space Effects. In: Theme C. Forecasting and Mitigation of Water-Related Disasters., XXXIX International Association of Hydraulic Research Congress Proceedings. Tsinghua University Press, Beijing, China, pp. 416-423.

References

- Tomozeiu, R., Pavan, V., Cacciamani, C., Amici, M., 2006. Observed temperature changes in Emilia-Romagna: mean values and extremes. *Clim. Res.*, 31(2-3): 217-225.
- Trenberth, K., 2011. Changes in precipitation with climate change. *Clim. Res.*, 47(1-2): 123-138.
- Trenberth, K.E., 1999. Atmospheric Moisture Recycling: Role of Advection and Local Evaporation. *J. Clim.*, 12(5): 1368-1381.
- Trenberth, K.E., Dai, A., Rasmussen, R.M., Parsons, D.B., 2003. The changing character of precipitation. *B Am Meteorol Soc*, 84(9): 1205-1217.
- Turner, A.G., Hannachi, A., 2010. Is there regime behavior in monsoon convection in the late 20th Century? *Geophys. Res. Lett.*, 37(16): L16706.
- Ueda, H., Iwai, A., Kuwako, K., Hori, M.E., 2006. Impact of anthropogenic forcing on the Asian summer monsoon as simulated by eight GCMs. *Geophys. Res. Lett.*, 33(6): L06703.
- Watt, W.E., Waters, D., and McLean, R., 2003. Climate change and urban stormwater infrastructure in Canada: Context and case studies., Meteorological Service of Canada, Waterloo, Ontario.
- WHO, 2002. Floods: climate change and adaptation strategies for human health, WHO (World Health Organization – Regional office for Europe).
- Wilby, R.L., Hay, L.E., Leavesley, G.H., 1999. A comparison of downscaled and raw GCM output: implications for climate change scenarios in the San Juan River basin, Colorado. *J. Hydrol.*, 225(1-2): 67-91.
- Wilby, R.L., Wigley, T.M.L., 2002. Future changes in the distribution of daily precipitation totals across North America. *Geophys. Res. Lett.*, 29(7): 1135.
- Willems, P., Vrac, M., 2011. Statistical precipitation downscaling for small-scale hydrological impact investigations of climate change. *J. Hydrol.*, 402(3-4): 193-205.
- Yang, W. et al., 2010. Distribution-based scaling to improve usability of regional climate model projections for hydrological climate change impacts studies. *Hydrology Research*, 41(3/4): 211-229.
- Zhang, X.B., Hogg, W.D., Mekis, E., 2001. Spatial and temporal characteristics of heavy precipitation events over Canada. *J. Clim.*, 14(9): 1923-1936.

Appended paper

I

Rana, A. (2011) Avoiding natural disaster in megacities – Case study for Urban Drainage of Mumbai. *Vatten* 67:55–59.

AVOIDING NATURAL DISASTER IN MEGACITIES – CASE STUDY FOR URBAN DRAINAGE OF MUMBAI

Att undvika naturkatastrofer i megastäder
– Fallstudie av dagvattensystem i Mumbai

by ARUN RANA, Department of Water Resources Engineering, LTH, Lund University
Box 118, 221 00 Lund, Sweden
e-mail: Arun.Rana@tvr.lth.se, arunranain@gmail.com



Abstract

“Nature’s fury, Man’s folly!” As people of Mumbai were getting ready for work and children’s for school on morning of 26 July 2005, they had no idea what is coming for them in next 48 hours. It rained heavily leading to massive floods and other related damages to life and property. We still are helpless to the forces of nature when it comes to natural calamities. Can we mitigate the human catastrophe and loss of property with better management techniques? Can computerized models help us in predicting and managing/minimizing losses due to calamities? Could this disaster be prevented in future? This is indeed a hurdle to be tackled by researchers. The present study has shown that improvement in drainage system could help avoid such disasters in the future. Better management practices should be applied along with disaster management programmes. People should be made aware of the civic sense by imparting education and a detailed map of drainage system should be prepared for future studies.

Key words – Natural Disaster, Flooding, Sustainable development, Drainage System, Urbanization, Intensity-Duration-Frequency, Climate Indices, Flood mapping, Climate change, Mumbai

Sammanfattning

Föga anade invånarna i Mumbai som var på väg till arbetet och skolan morgonen den 26 juli 2005 vad som väntade dem de kommande 48 timmarna. Kraftigt regnande ledde till massiva översvämningar och medföljande skador på liv och egendom. Vi är fortfarande hjälplösa inför naturens krafter när det gäller naturkatastrofer. Kan vi mildra människors lidande och förlust av egendom med bättre ledningsmetoder? Kan datormodeller hjälpa oss att förutsäga och hantera/begränsa skador orsakade av naturkatastrofer? Kan liknande tragedier förhindras i framtiden? Detta är en riktig nöt att knäcka för forskarna. Denna studie har visat att förbättrade dagvattensystem kan bidra till att undvika liknande katastrofer i framtiden. Bättre medoder för ledning och katastrofhanterings bör införas. Utbildning om medborgaransvar bör genomföras och en detaljerad karta över dagvattensystem bör skapas för framtida studier.

Introduction

We are aiming for sustainable future but we have a big question to answer – how shall we deal with the effects of a changing climate? In recent times we have seen many examples of effects of a changing climate worldwide including floods, droughts and extremes of hot and cold temperatures. Global average precipitation is pro-

jected to increase, but both increases and decreases are expected at the regional and continental scales (IPCC, 2001 and 2007). Most part of the population is living in urban areas making them more vulnerable in situations of natural calamity. A major part of urban infrastructure deals with drainage system and its management which is rather poorly handled leading to floods. Here rises a question in our minds whether the severe consequences

of floods in Mumbai in 2005 were due to inadequate drainage, bad planning/management or it was natural calamity where one would feel helpless?

The megacity Mumbai after deluge in 2005

Mumbai serves as the economical hub of India. It is home to almost 14 million people with total area of 437 km² leading to population density of around 27 000 people per km². Life in Mumbai came to a standstill when it poured heavily on 26 and 27 July 2005 leading to massive floods. The unprecedented rainfall of 994 mm during the 24 hours resulted in that at least 419 people (and 16000 cattle) were killed (Gupta, 2007). It caused, as a result of the following flash floods and landslides in the Mumbai municipal area, death of another 216 from flood-related illnesses. Over 100 000 residential and commercial establishments and 30 000 vehicles were damaged, causing direct economic damages estimated at almost two billion USD and many more indirect monetary damages (Hallegatte et al., 2010). The extremely high rainfall resulted in overflows from the already inadequate drainage system. The storm water could not be drained out to the sea because of the simultaneous maximum high tide level of 4.5 m. There have been changes in trend of rainfall for both short and long period of time. Trends in rainfall for Mumbai are studied in detail by Rana et al. (2010), they presented evidences of a changing rainfall pattern related to global climatic phenomena. Also, the unprecedented rainfall in 2005 was extreme event with return period far more than 120 years which can be easily observed from IDF curves prepared by Rana et al., 2011.

Present Situation of Drainage System

The drainage system in any city depends on its topography. Mumbai is a cluster of seven islands, and the current system was built well before Independence on 15 August 1947. Mumbai is lined by the Arabian Sea on the western side, and also being intercepted by the Mahim, Mahul and Thane creeks, along with the Mithi, Dahisar, Poisar and Oshiwara rivers and their respective tributaries. The drainage system of Mumbai is a mix of simple drains (nallah) and a complicated network of rivers, creeks, drains and ponds but no natural drainage outlet. At present, the storm water drainage system consists of a hierarchical network of road side surface drains (about 2000 km mainly in the suburbs), underground drains and laterals (about 440 km in the island city area), major and minor nallahs (200 km and 87 km respec-

tively), and 186 outfalls, which discharge all the surface runoff into the rivers and the Arabian Sea. Table 1 represents the summary of storm water drains in Mumbai with their length in km (City Development Plan (CDP), Mumbai). A network of closed drains below the roads has evolved in the city along with drains in the suburbs (figure 1). The southern city area has long complex networks which drains relatively large low-lying areas, while short drains from small areas drain directly to the sea. The central area forms a depression, flanked by hills, and being on reclaimed grounds barely two to three meters above sea level. As in central Mumbai (island city), natural drainage has been visibly affected by urban building activity also in the suburbs.

Mumbai has a two-tier sewerage system. One is the underground sewerage system that discharges about 3.5 km into the sea. The other is storm water drains that carry surface and flood water during monsoon and discharges directly into the sea right at the sea shore. There is a large network of road side open drains in suburbs. The collection, conveyance and disposal of waste water and sewage in Mumbai is divided into seven zones, viz., Colaba, Worli, Bandra, Versova, Malad, Bhandup and

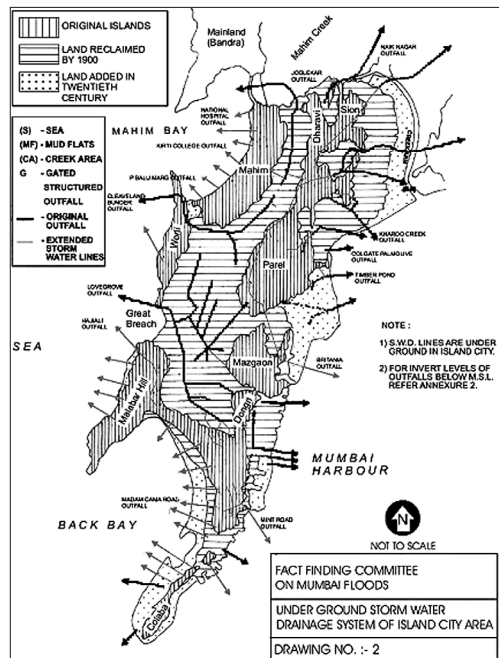

Figure 1. Drainage of Mumbai City area, Gazetteer of India, Maharashtra State, History of Bombay, Modern Period 1987 (Government of Maharashtra 2006).

Table 1. Summary of the Storm Water Drainage System of Mumbai (CDP, Mumbai).

S.No.	Drain Hierarchy/Type	Length (km)			
		Island city	Western suburbs	Eastern Suburbs	Total
1	Major Nallah (width>1.5 m)	9	90	102	200
2	Minor Nallah (width<1.5 m)		21	66	87
3	Arch/Box drains	59	40	52	151
4	Roadside open drains	20	669	1298	1987
5	Closed pipe or dhaka drains	443	36	86	565
6	Total SWD length	531	857	1603	2991
7	No. of water entrances	27893	609	1706	30208

Ghatkopar (figure 1). From each of these, sewage and waste water is conveyed to the respective final discharge points for disposal through marine outfalls, some three kilometres into the sea. Though sewerage lines are laid in zones, due to rapid expansion, development, dense population and non-accessibility in some of the parts particularly in extended suburbs and slums is connected to storm channels. Out of the 186 outfalls (i.e point where creek meets the sea), there are 107 major outfalls in the city, which drain directly into the Arabian sea (4 at Mahim creek and 4 at Mahul creek). There are 29 out-falls in the western suburbs draining directly in the sea, while 14 drain into the Mithi river, which ultimately joins the Mahim creek. In the eastern suburbs, 14 out-falls discharge in the Thane creek and 6 in the Mahul creek. Table 2 summarises the storm water discharge system of Mumbai (CDP, Mumbai).

The present storm water drainage system in the city, which was put in place at the beginning of the 20th century, is 70 years old and about 480 km in length. It is capable of handling rain intensity of 25 mm per hour at low tide. This amount is generally exceeded on a routine basis during the monsoon season in Mumbai. The drain system works with the aid of gravity, with no pumping stations to speed up the drainage. Parts of the city like the Bombay Central and Tardeo remain below sea level. All along the shore fringes, extensive areas are flooded during high tides, during the heavy monsoon rains, many low lying areas are flooded and do not readily get

drained. Some of the main problems related to the storm water drainage system of Mumbai are elaborated below:

- There is no map of underground cables and pipes: Thousands of underground cables (telephone, water pipelines) need to be mapped, and in some cases, shifted to accommodate the restructured/restructured drains.
- Slums on drains: The large number of people living on the top of and adjacent to the existing drains needs to be displaced and rehabilitated.
- Lack of civic sense: This results in clogging of drains, due to debris and garbage being disposed off in them, by the people.
- Lack of proper maintenance: The Brihanmumbai Municipal Corporation (BMC) often does not complete cleaning the drains before the monsoon sets. Work is also not done properly; garbage is left on the sides of the road and when it rains, it returns back to the drains, thereby choking the water passage.
- Many gradients are flat and the drains are affected by tides.
- A large number of drains are found to be of inadequate capacity.
- Poor workmanship and lack of attention to proper repairs when the drains have been punctured to construct utility services has left many of these locations in a poor state of structural repair.
- Interconnection of storm water and sewerage networks.

Table 2. Summary of the storm water discharge system in Mumbai (lengths in km) (CDP, Mumbai).

S.No.	Outfall discharging into	Length (km)			
		In island city area	In western suburbs	In eastern suburbs	Total
1	Arabian Sea	107	29	0	136
2	Mahim creek	4	14	8	264
3	Mahul creek	4	0	6	10
4	Thane creek	0	0	14	14
	Total	115	43	28	186

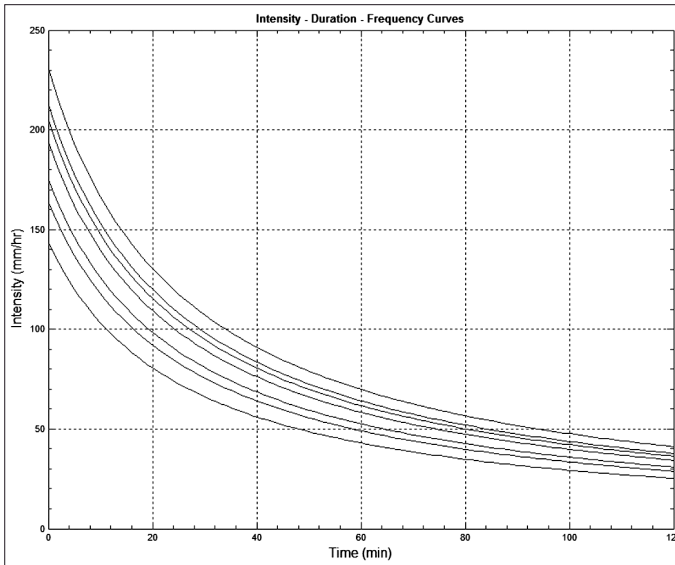

Figure 2. *IDF curves – Graphical representation of relationship of intensity duration and frequency of rainfall for Mumbai. (Return periods are 5, 10, 15, 30, 45, 60, 120 years respectively starting from below in the curves).*

Cause-Effect Relationship

At the Department of Water Resources Engineering, Lund University, the cause-effect relationship of the consequences of the storm in 2005 is analyzed. Historical rainfall data have been collected and statistical analysis is performed to establish a relation between rainfall and frequent flash floods in the city. The rainfall analysis revealed that there is fluctuation in the amount, duration and intensity of rainfall which was further related to climatic indices (Tele-connection patterns of trends/anomalies in atmospheric or hydrological parameters due to global circulation pattern) arising from different global circulation model (Rana et al., 2010). These fluctuations are on decadal basis and are expected to continue in near future in co-relation with climatic indices. The rainfall analysis was followed by analysis of the drainage system of the city which is in bad condition as the natural drains in the city are absent and man-made drains are either inadequate due to faulty design or clogged due to poor maintenance.

Urban drainage system: how and why?

Drainage system of any city is designed based on IDF Curves (Intensity Duration and Frequency) of rainfall. The IDF curves, used for designing drainage system in Mumbai, were poorly developed and have not been revised for a long time. We further proceeded with

development of fresh IDF curves based on long time historical data from Indian Metreological Department (IMD) for period 1951–2004 (figure 2) (Rana et al., 2011). While designing new IDF curves the future scenario/projections for rainfall over the grid point of Mumbai were taken into account. It was important to take this future scenario in consideration as experts have expected change in atmospheric phenomena’s owing to climate change.

The climate change scenario is further supported by different IPCC (Inter-governmental Panel on Climate Change) reports. When the statistical analysis was carried out it was revealed that there is some change in rainfall expected in near future in relation to climate indices. So, for development of historical and future IDF curves there were a need of high quality fine time resolution data of rainfall which is not available in case of Mumbai, as is the case in many developing countries. There are daily rainfall data for the city available from Indian metrological department. For the future climate projections, data was taken from two different climate models namely PCM1 (Parallel Climate Model) model output – SresB07.58 experiment for 1990 to 2099 and CMIP5 (5th coupled model inter-comparison project) model output – HadGEM2-ES model experiment rcp45 for 2005 to 2099 from National Centre for Atmospheric Research and British Atmospheric Data Centre respectively (accessed from ESG – Earth System Grid Gateway). This daily data was disaggregated into finer time scale using cascade based model for development of IDF

curves fitting Gumbel distribution to data. Readers can refer to Rana et. al. (2011) for detailed procedure on disaggregation of rainfall and development of IDF curves. The developed IDF curves for future scenario gives a clear idea of the rainfall intensity increasing in the study area. They can be very handy for planning and development of city in future infrastructure works. Once these curves were established it could be seen how frequent flooding could be expected and planning can be done accordingly. According to Rana et. al. (2011), where both historical and projected IDF curves have been developed, the intensity of rainfall is increasing in future climate scenario. They have provided a detailed account of different intensity v/s time scenario with different return period.

Future work and prospects

It is evident from the analysis of drainage system that the infrastructure for city of Mumbai is not able to cope with intensity of rainfall as they are found to be inadequate in capacity along with many other problems namely development of slums on drains leading to decrease in capacity, lack of civic sense resulting in clogging of drains due to debris and garbage, flat gradients and poor workmanship and lack of attention. These problems were also highlighted by other authors. Gupta (2007) discussed the inadequate capacity of drainage systems. He showed that by recent data analysis for the years 1999 to 2004, the peak rainfall intensity for a 15 min duration exceeds 72 mm/h which is over 80% of the times the drainage capacity of the city. There is a clear need for upgrading the drainage systems along with other soft skill measures to control the burden on city (Gupta, 2007).

The research presented here does not only include analysis of rainfall but also aims for looking at the consequences of flooding and finding solutions for mitigating flooding problems. Flood simulations are performed to prepare for better management of disasters. The synthesis of this modeling would be presented in form of flood hazard maps, which then can be used for management and finding system for controlling the storm water. A sustainable solution for drainage of city is sought for. Possibilities for rain water harvesting will be investigated with the intention to use rain water in the households, in industries and for groundwater recharge. Measures of flood prevention, safe disposal of waste and wastewater handling in slums forms a significant part of the work in urge for finding best possible solution. Soft skills development and education on the same issue by issuing guidelines, seminars and talks in society forms the final part of the work. Suggestions for development of permeable green zones and reduction of urban heat

island affect in the city forms a major part of the suggestions.

The case scenarios where sea level rise or failure of drains could lead to heavy damages of human life and property, will also focused in the study and emphasis would be laid on finding sustainable solution for Mumbai as an example of a megacity situated by sea. Some studies suggest that by the 2080s, in a climate change scenario could see the likelihood of a 2005-like event more than double. The estimated total losses (direct plus indirect) associated with a 1-in-100 year event could triple compared to current situation (to \$690 – \$1890 million USD) (Hallegatte et al., 2010). Estimates have also suggested that improvement in the drainage system can reduce the losses of 100 year return period flood by almost 70 percent. The present work would help achieve sustainable solution for the city of Mumbai and would serve as a guideline for many other urban centers across the world dealing with same problem. Although there are uncertainties about the magnitude and direction of future climate variations at various places, measures must be initiated to minimize the adverse impacts of these changes on society and resources for a sustainable future.

References

- Government of Maharashtra, Report of the Fact Finding Committee (FFC) on Mumbai Floods, 2006.
- Greater Mumbai City Development Plan. Storm Water Drainage. Available at: http://www.mcgm.gov.in/irj/portalapps/com.mcgm.ahome_keyprojects/docs/2-6%20Storm%20Water%20Drainage.pdf. (accessed on 27 September, 2010).
- Gupta, K. (2007) Urban flood resilience planning and management and lessons for the future: a case study of Mumbai, India. *Urban Water Journal* 4(3), 183–194.
- Hallegatte, S. et al. (2010), “Flood Risks, Climate Change Impacts and Adaptation Benefits in Mumbai: An Initial Assessment of Socio-Economic Consequences of Present and Climate Change Induced Flood Risks and of Possible Adaptation Options”, OECD Environment Working Papers, No. 27, OECD Publishing. doi: 10.1787/5km4hv6wb434-en
- Intergovernmental Panel on Climate Change (IPCC). 2007. “Climate change 2007: The physical science basis – Summary for policy makers.” Contribution of Working Group I to the Fourth Assessment Report of the Intergovernmental Panel on Climate Change, Intergovernmental Panel on Climate Change, Geneva.
- McCarthy JJ, Canziani OF, Leary NA, Dokken DJ, White KS, (Eds.) (2001) In: *Climate Change – Impacts, Adaptations and Vulnerability*. Intergovernmental Panel on Climate Change (IPCC) Report.
- Rana, A., Bengtsson, L., Jothiprakash, V., Olsson, J. and Singh, W. (2011) Establishment of rainfall Intensity-Duration-Frequency curves under changing climate scenario. *Hydrological Processes* (Submitted).
- Rana, A., Uvo, C. Bengtsson, L. and Sarthi P.P. (2010) Trend analysis of rainfall for Delhi and Mumbai, India. *Climate Dynamics*. DOI: 10.1007/s00382-011-1083-4.

Appended paper

II

Rana, A., Uvo, C. Bengtsson, L. and Sarthi P.P. (2012) Trend analysis of rainfall for Delhi and Mumbai, India. *Climate Dynamics* 38 (1):45-56. doi:10.1007/s00382-011-1083-4.

Trend analysis for rainfall in Delhi and Mumbai, India

Arun Rana · Cintia Bertacchi Uvo ·
Lars Bengtsson · P. Parth Sarthi

Received: 15 June 2010 / Accepted: 19 April 2011
© Springer-Verlag 2011

Abstract Urbanisation has burdened cities with many problems associated with growth and the physical environment. Some of the urban locations in India are becoming increasingly vulnerable to natural hazards related to precipitation and flooding. Thus it becomes increasingly important to study the characteristics of these events and their physical explanation. This work studies rainfall trends in Delhi and Mumbai, the two biggest Metropolitan cities of Republic of India, during the period from 1951 to 2004. Precipitation data was studied on basis of months, seasons and years, and the total period divided in the two different time periods of 1951–1980 and 1981–2004 for detailed analysis. Long-term trends in rainfall were determined by Man-Kendall rank statistics and linear regression. Further this study seeks for an explanation for precipitation trends during monsoon period by different global climate phenomena. Principal component analysis and Singular value decomposition were used to find relation between southwest monsoon precipitation and global climatic phenomena using climatic indices. Most of the rainfall at both the stations was found out to be taking place in Southwest monsoon season. The analysis revealed great degree of variability in precipitation at both stations. There is insignificant decrease in long term southwest monsoon rainfall over Delhi and slight significant decreasing trends for long term southwest monsoon

rainfall in Mumbai. Decrease in average maximum rainfall in a day was also indicated by statistical analysis for both stations. Southwest monsoon precipitation in Delhi was found directly related to Scandinavian Pattern and East Atlantic/West Russia and inversely related to Pacific Decadal Oscillation, whereas precipitation in Mumbai was found inversely related to Indian ocean dipole, El Niño-Southern Oscillation and East Atlantic Pattern.

Keywords Urbanization · India · Statistical analysis · Man-Kendall · Climate indices · Principal component analysis · Singular value decomposition

1 Introduction

Urbanization has established a network of competitive urban centres that set the physical reference points for today's globalization. Some of the urban locations in India are becoming increasingly vulnerable to natural hazards related to weather and climate (De and Dandekar 2001). Global averaged precipitation is projected to increase, but both increases and decreases are expected at the regional and continental scales (IPCC 2001). Information about the trends of rainfall are important as it is closely related to the practical water relates issues in the region especially flood related problems. Thus it becomes increasingly important to study the trends in precipitation and their physical explanation.

Several studies have addressed the important issue of trends in rainfall in India since last century. For example, Guhathakurta and Rajeevan (2006) have shown that there is no long term trend in the southwest monsoon seasonal rainfall over the country, when about 60–90% of the annual rainfall over India is received (Joshi and Rajeevan 2006),

A. Rana (✉) · C. B. Uvo · L. Bengtsson
Department of Water Resources Engineering, LTH,
Lund University, Box No. 118, 22100 Lund, Sweden
e-mail: Arun.Rana@tvrl.lth.se; arunranain@gmail.com

P. Parth Sarthi
Center for Environmental Sciences, Central University of Bihar,
Camp Office: BIT Campus-Patna, P.O.-B.V. College, Patna,
Bihar 800014, India

but there are significant regional variations. Long term southwest monsoon/annual rainfall trends over India as a whole were previously studied by Pramanik and Jagannathan (1954), a pioneer work in organizing series of annual rainfalls over 80–100 years ending in 1950, found systematic variations over certain regions in addition to random fluctuations. These findings were later corroborated by Mooley and Parthasarathy (1984) and by Parthasarathy et al. (1993). Rao and Jagannathan (1963), Thapliyal and Kulshrestha (1991) and Srivatsava et al. (1992) analyzed the data organized by Pramanik and Jagannathan (1954) and reported no trends for an average time series, for all India, of southwest monsoon/annual rainfall. Regionally Pant and Borgaonkar (1984) did not find any trend in rainfall over the hilly region of Uttar Pradesh. No trends were reported over western Himalaya on seasonal and annual rainfall during the period 1893–1990 by Pant et al. (1999). Singh and Sontakke (1999) studied Post monsoon rainfall from 1871 to 1980: northwest India, 1844–1996; North Central India, 1842–1996; northeast India, 1829–1996; West Peninsular India, 1841–1996; East Peninsular India, 1848–1996; and South Peninsular India, 1813–1996 and concluded that these areas do not possess a significant long-term trend, and were weakly correlated.

Long term trends in annual rainfall on small spatial scale were reported; among others, by Koteswaram and Alvi (1969) over west coast of India, by Jagannathan and Bhalme (1973), during the monsoon season for each of the years 1901–1951 for a network of 105 stations over India; by Parthasarathy (1984) over two subdivisions viz. sub-Himalayan West Bengal and Sikkim and the Bihar Plains that showed decreasing trends in monsoon rainfall, and for the four subdivisions viz. Punjab, Konkan and Goa, West Madhya Pradesh and Telangana that showed increasing trends; by Chhabra et al. (1997) that indicated a decrease in the precipitation in hilly stations and an increase in the precipitation in the urbanized/industrialized cities; and by Naidu et al. (1999) on annual rainfall for 29 sub-divisions of India by using the rainfall series for a period of 124 years (1871–1994). Recently, Goswami et al. (2006) indicated significant positive trends in the frequency and the magnitude of extreme rain events and a significant negative trend in the frequency of moderate events over central India during the monsoon seasons from 1951 to 2000.

The relation between precipitations in India and global climate phenomena is well known, however their association to precipitation trends is not as well explored. Roy (2006) has indicated that the Pacific Decadal Oscillation (PDO) and El Niño-Southern Oscillation (ENSO) have negative relationship with winter rainfall in almost all north and central parts of India whereas SST around the mainland have negative correlation with rainfall in peninsular

India. Singh (2001) have also shown the negative relationship of pre-monsoon ENSO conditions to the amount of precipitation taking place in north-western and peninsular India. A major shift in total rainfall during recent years has been observed which shows that they might be following periodical cycles of PDO, ENSO and local SSTs, (Roy 2006). Joseph and Xavier (1999) have reported a strong decreasing trend in the monsoon depression frequency during last 100 years. Kumar and Dash (2001) showed that the decadal frequency of number of depressions was decreasing in recent years.

The present research is aimed at analyzing trends in precipitation in the cities of Delhi and Mumbai and seeks for physical explanation to trends during southwest monsoon season on global climate phenomena as expressed by climatic indices. We aim to investigate the long term trend in southwest monsoon rainfall and the possible effect of global climatic phenomena. Statistical linear methods are used for recognizing trends and their physical explanation. Delhi is located at 28°37'N 77°14'E, and lies in northern India whereas Mumbai is located at 18°58'30"N 72°49'33"E in south western part of India. This study has been divided into three sections. Section 2 deals with data used and methodology, Sect. 3 deals with results and discussion where we presented analysis of monthly precipitation, analysis of annual and decadal precipitation, of seasonal precipitation, of maximum daily precipitation per year and climate relation of trends, finally in Sect. 4 conclusions are outlined.

2 Data used and methodology

For this study, daily accumulated rainfall data was obtained from India Meteorological Department (IMD) and monthly climatic indices data were obtained from the National Weather Service, Climate Prediction Centre (NOAA). Data for Delhi, Mumbai and climatic indices including Scandinavian Oscillations (SCA), East Atlantic/West Russia (EA/WR), West Pacific (WP), North Atlantic Oscillations (NAO), East Pacific/North Pacific (EP/NP), Indian Ocean Dipole (IOD), El Niño-Southern-Oscillation (NINO 3.4), Pacific Decadal Oscillation (PDO), East Atlantic (EA) and Pacific/North American Oscillations (PNA) considered in the study are from 1951 to 2004.

From the basic daily rainfall data, monthly means, median, percentiles, seasonal totals, Standard Deviation (SD) and percentage contribution to annual rainfall were computed monthly and season-wise viz., Pre-monsoon (March–May), Southwest monsoon (June–September), Post-monsoon (October–November) and Winter (December–February). A linear trend line was added to the series for identifying the trends. The data was subjected to Mann–

Kendall test for trend analysis in different time periods from 1951 to 1980, 1981 to 2004 and also from 1951 to 2004 for all the seasons and annually so as to see changes in precipitation on decadal basis. The data was also analyzed for daily extreme/Maximum precipitation events per year.

The linear regression method is widely used to determine long-term trends seasonally, annually, and for daily maximum precipitation (e.g. Gadgil and Dhorde 2005, among many others). The non-parametric Mann–Kendall test, which is another popular statistical method used by contemporary climatologists (e.g. Gadgil and Dhorde 2005; Tomozeiu et al. 2006 and many others) is used here as a significance test. The major advantages of this test highlighted by Rio et al. (2005) are: (1) No assumptions about distribution are necessary and (2) it is directly applicable to climate data for a given month or season. The procedure of carrying out this statistical test is outlined by Mitchell et al. (1966).

Further, trends in total precipitation during the southwest monsoon (June–September) at these stations were compared to climatic indices/tele-connection patterns in seeking for a physical explanation to observed trends. Principal component analysis (PCA) and Singular value decomposition (Bretherton et al. 1992) were used to investigate such relationship. Both methods isolate important coupled modes of variability between time series of two different fields.

PCA, which maximizes variance explained by weighted sum of elements in two or more fields, was first proposed by Pearson (1902). It identifies linear transformations of the dataset that concentrate as much of the variance as possible into a small number of variables. First applications to meteorology were by Fukoka (1951), Lorenz (1956), Holmstrom (1963) and Obukhov (1960). The lucid exposition of PCA by Katzbach (1967) was instrumental in promoting the use of this technique in climate research. Katzbach (1967) pointed out that two or more field variables can be combined in the same PCA to document the relationship between the fields. It isolates the modes of variability observed in time series of different fields and gives their relationships in separate modes.

SVD is a fundamental matrix operation, a generalization of the diagonalization procedure that is performed in PCA to the matrices that are not squared or symmetric. SVD was first used in meteorological context by Prohaska (1976), later by Lanzante (1984) and Dymnikov and Filin (1985). As applied by Bretherton et al. (1992), SVD is performed to the cross-covariance matrix of two fields and isolates the linear combinations of variables within the fields that tend to be linearly related to one another by maximizing the covariance between them. Here SVD is applied to the cross-covariance matrix of the $s(t, x)$ matrix of x climatic

indices (called as predictant) at t years and the $\mathbf{z}(t, y)$ matrix composed by total monsoon precipitation in Delhi and Mumbai at t years, this might be called as predictor. All time series are standardized to zero mean and unit standard deviation prior of use in the SVD. The data time series $s(t)$ and $\mathbf{z}(t)$ for each variable can be expanded in terms of a set of N vectors, called pattern (Bretherton et al. 1992). Here we try to estimate the predictor on basis of predictant.

$$s(t) \leftarrow \bar{s}(t) \equiv \sum_{k=1}^N a_k(t) p_k$$

$$z(t) \leftarrow \bar{z}(t) \equiv \sum_{k=1}^N b_k(t) q_k$$

The time series $a_k(t)$ and $b_k(t)$ are called expansion series; p_k and q_k are the patterns. The expansion coefficients are calculated as weighted linear combination of variables in data.

$$a_k(t) = \sum_{i=1}^{N_s} u_{ik} s_i(t) = u_k^T s(t)$$

$$b_k(t) = \sum_{j=1}^{N_z} u_{jk} z_j(t) = v_k^T z(t)$$

The vectors u_k and v_k are called weight vectors. Together, each pair of patterns, the corresponding pair of weight vectors and the pair of expansion coefficients defines a mode, which combines the variability observed in different fields. The variables in the s and z fields are subscripted by i and j , respectively, and individual modes by k . Further square covariance fractions were calculated to give the percentage of squared covariance fraction explained by predictor in the predictant field in particular mode. This can be used to compare the relative importance of particular mode in the expansion.

3 Results and discussion

3.1 Analysis of monthly precipitation

Rainfall characteristics of Delhi and Mumbai are represented in Fig. 1 in form of box plot and Tables 1, 2. The annual mean rainfall over Delhi and Mumbai from 1951 to 2004 is 715 and 2,142 mm with a standard deviation of 199 and 3,516 mm, respectively (Table 1). For Delhi, rainfall during August is the highest (234 mm) and contributes to 32% of annual rainfall (715 mm), followed by July (28%), September (16%) and June (8%) of the annual rainfall. Rainfall in November is the least (4 mm) and contributes only 0.6% to the annual rainfall. The coefficient of

variation is highest during April (284%), followed by November (240%) and December (203%) and the least during the high rainfall months of July (57%) and August (57%). Rainfall during the southwest monsoon (June–September) contributes 85.9% of the annual rainfall. The contribution of pre-monsoon (March–May), post-monsoon (October–November) and winter rainfall (December–February) to annual rainfall is 5, 3 and 5% respectively. Whereas for Mumbai, rainfall during July is the highest (777 mm) and contributes to 36% of annual rainfall (2,142 mm), followed by June (23%), August (23%) and September (13%) of the annual rainfall, respectively. Rainfall during the southwest monsoon (June–September) contributes 96% of the annual rainfall. The contribution of pre-monsoon (March–May), post-monsoon (October–November) and winter rainfall (December–February) to annual rainfall is 0.8, 3 and 0.1%, respectively.

3.2 Analysis of annual and decadal precipitation

The mean annual rainfall over Delhi showed no significant declining trend during the entire study period (Fig. 2a). However, the annual rainfall in the period 1981–2004 showed a relative decrease when compared to 1951–1980 (Fig. 3a; Table 2). These results are corroborated by the Man-Kendall Test (Table 3). The mean annual rainfall over Mumbai showed a long term significant negative trend that is statistically significant at the 0.05 significance level (Fig. 2a). The negative trend in annual rainfall is statistically significant when considered the period of 1951–1980; however, the apparent positive trend during the 1981–2004

periods is not statistically significant (Fig. 3a). Mumbai also showed a significant negative trend for the southwest monsoon season (Fig. 3c). All trends in rainfall are tested for significance at 0.05 level using the Man-Kendall Test and test results is presented in Table 3.

3.3 Analysis of seasonal precipitation

For Delhi, Pre-monsoon (March–May) rainfall showed insignificant decreasing trend in both data periods (Fig. 3b). As it rains very little during this season, no conclusion can be drawn about the changed precipitation. Southwest monsoon (June–September) rainfall (676 mm) was higher from 1951 to 1980 against the long term mean (614 mm) while lower (536 mm) from 1981 to 2004. The increasing trend of precipitation was not significant during both data periods (Fig. 3c). Post-monsoon (October–November) rainfall depicts the same pattern as pre-monsoon rainfall with decreasing trends in both data periods (Fig. 3d). Winter (December–February) rainfall had an increasing trend during 1981–2004 and decreasing trend during 1951–1980, which is, however, not statistically significant (Fig. 3e).

Seasonal rainfall trends at Mumbai are significant in some seasons during data period of 1951–1980 and 1951–2004 (Table 3). Pre-monsoon (March–May) rainfall showed statistically insignificant increasing trend in both data periods (Fig. 3b). The increase was sharper during the later period of study. Southwest monsoon (June–September) rainfall was major part of rainfall in whole data period. There was a significant decreasing trend in rainfall during

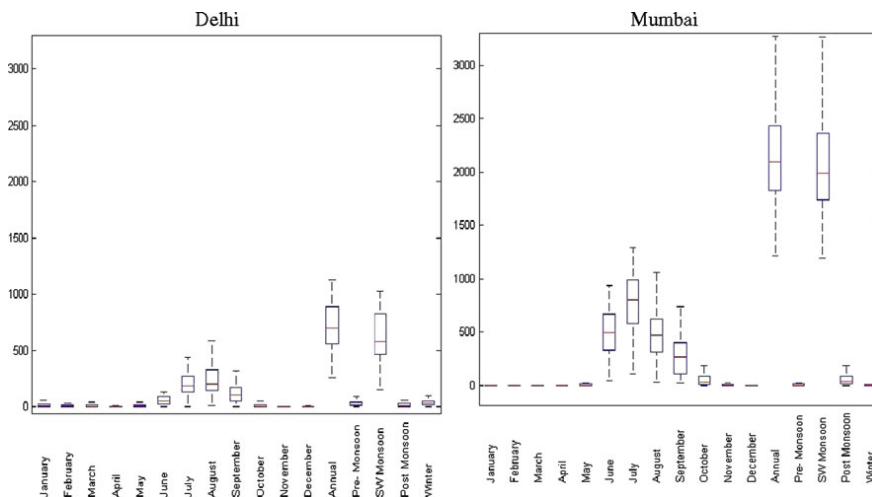

Fig. 1 Monthly and seasonal rainfall at Delhi and Mumbai during data period of 1951–2004

Table 1 Monthly (only those which contribute to % of annual rainfall) and seasonal rainfall at Delhi and Mumbai during data period of 1951–2004

Month	Delhi				Mumbai			
	Mean	SD	CV (%)	% to Annual	Mean	SD	CV (%)	% to Annual
June	58.1	40.3	69.4	8.1	504.1	218.6	43.4	23.5
July	204.7	117.1	57.2	28.6	777.5	269.3	34.6	36.3
August	234.5	135.6	57.8	32.8	493.5	247.5	50.2	23.0
September	116.9	89.4	76.5	16.3	282.3	200.0	70.8	13.2
Annual	715.5	199.6	27.9	100.0	2142	3516	164.2	100.0
Pre-monsoon	36.0	61.1	169.9	5.0	16.8	80.1	477.9	0.8
Southwest monsoon	614.2	493.3	80.3	85.9	2057	1170	56.9	96.0
Post monsoon	24.8	62.2	250.7	3.5	65.3	125.2	191.6	3.1
Winter	40.5	57.1	141.1	5.7	2.7	10.5	387.9	0.1

Table 2 Variation in seasonal rainfall at two stations during different data period of 1951–1980 and 1981–2004

Data period	Season	Delhi				Mumbai			
		Mean	SD	CV (%)	% to Annual	Mean	SD	CV (%)	% to Annual
1951–1980	Pre-monsoon	28.7	40.7	141.9	3.7	14.5	68.6	473.2	0.6
	Southwest monsoon	676.2	532	78.7	87.2	2232	1241	55.6	96.5
	Post monsoon	31.0	77.2	249.2	4.0	63.8	132	208.1	2.8
	Winter	39.5	26.1	66.1	5.1	2.8	11.7	422.1	0.1
	Annual	775.3	206	26.6	100.0	2314	3791	163.9	100.0
1981–2004	Pre-monsoon	45.1	79.0	175.2	7.0	19.6	93.0	474.3	1.0
	Southwest monsoon	536.8	430	80.2	83.8	1838	1041	56.7	95.4
	Post monsoon	17.0	34.6	203.1	2.7	67.2	116	173.1	3.5
	Winter	41.7	55.5	133.2	6.5	2.6	9.0	338.4	0.1
	Annual	640.6	166	25.9	100.0	1927	3133	162.5	100.0

the 1951–1980 periods and an insignificant increasing trend during 1981–2004 (Fig. 3). Also, the monsoon rainfall has decreased from 2,232 mm in 1951–1980 to 1,838 mm in 1981–2004. The decreasing trend during the 1951–2004 in monsoon rainfall is statistically significant at 0.05 levels. Post-monsoon (October–November) rainfall depicts decreasing trends in both data period with slight increase above the long-term mean in 1981–2004 (Fig. 3d). Winter (December–February) rainfall had a slightly increasing tendency during both data periods, which is not statistically significant (Fig. 3e).

3.4 Analysis of maximum daily precipitation per year

The Mann–Kendall test was applied to determine possible trends on maximum precipitation in a day per year and results are depicted in Table 4. It can be inferred from Table 4 that maximum precipitation in a day per year presents a significant ($P = 0.013$) negative trend for Delhi

during the period 1951–2004, in agreement with Fig. 3. In Mumbai, a significant ($P = 0.046$) negative trend is observed during 1951–1980 and ($P = 0.08$) during 1951–2004 (Fig. 4). Other detected trends were not statistically significant. Delhi and Mumbai generally have extreme precipitation events during southwest monsoon period which decrease, in number of occurrences, in the later data period.

3.5 Climatic relation of the trends

Monsoon rainfall data for Delhi and Mumbai were tested for relation against PDO, NINO3.4, IOD, EP/NP, NAO, WP, SCA, EA/WR, PNA and EA climatic indices using PCA and SVD. Average southwest monsoon rainfall (June–September) for both stations and average of climatic indices for the same season, for the whole data period, were used for analysis. PCA revealed a close relationship that is direct or inverse between some of these climatic indices

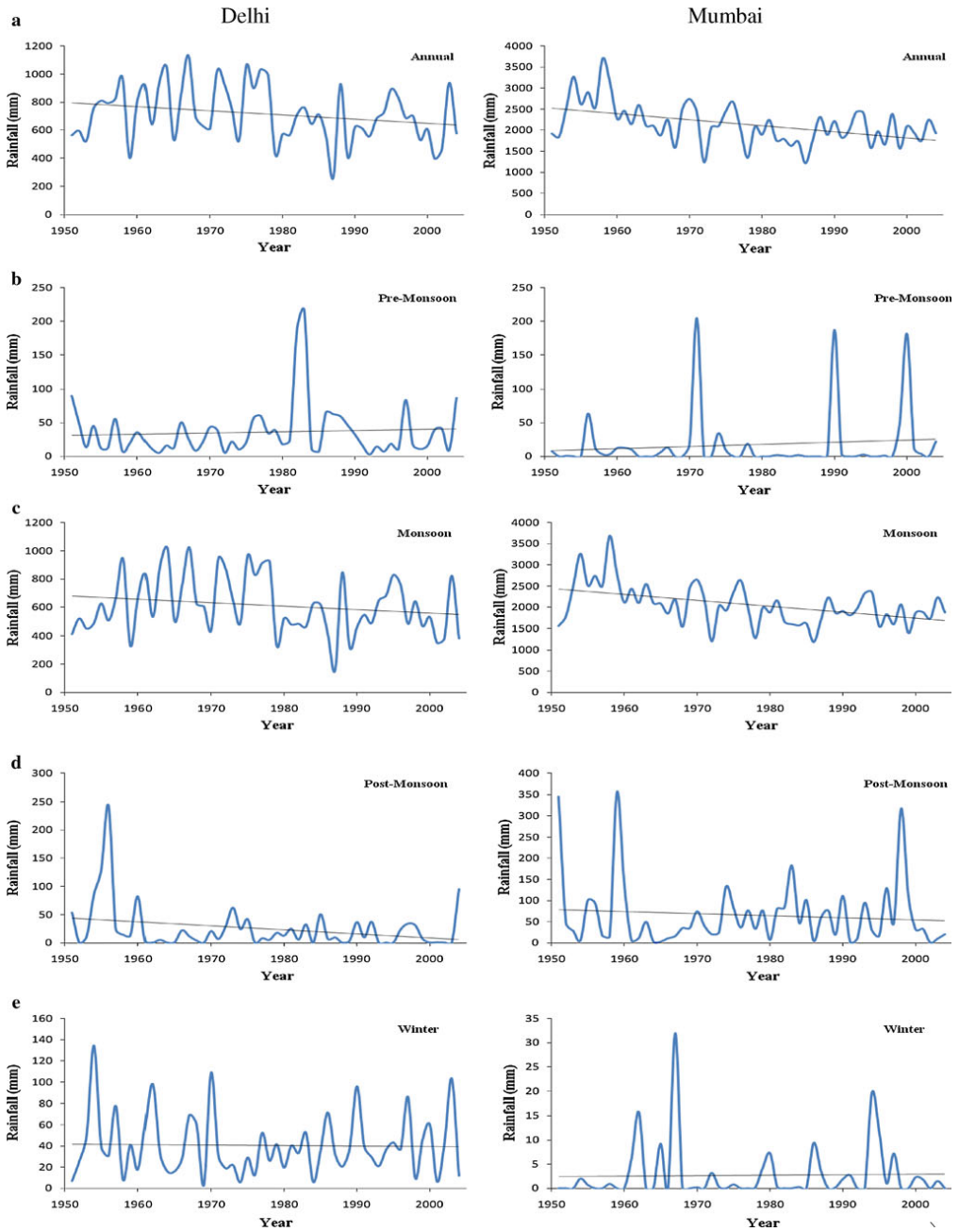

Fig. 2 Trends in seasonal and annual rainfall at the two stations during 1951–2004

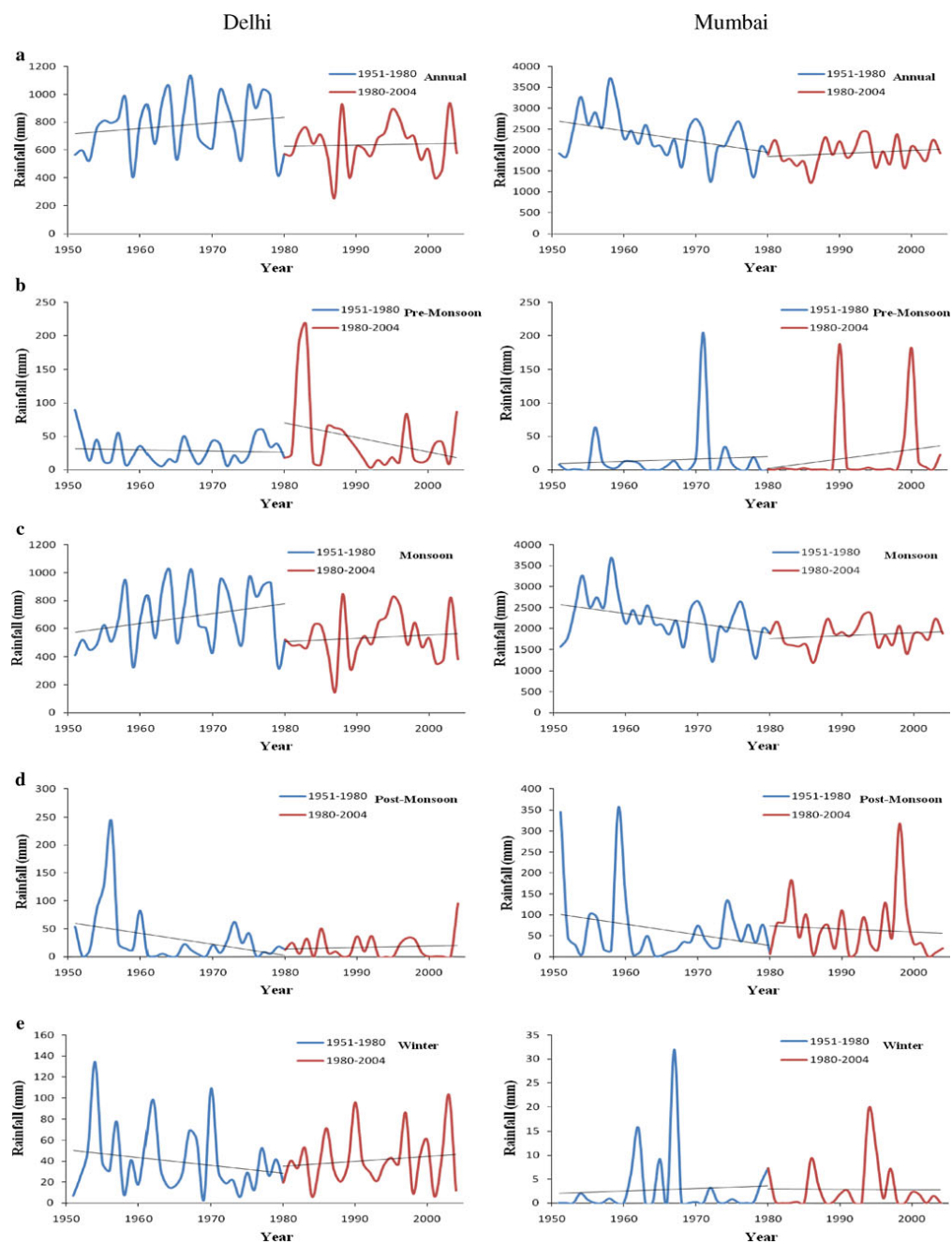

Fig. 3 Trends in seasonal and annual rainfall at the two stations during 1951–1980 and 1980–2004

Table 3 Man-Kendall statistics for annual and seasonal rainfall trends for the two stations

Data period	Season	Delhi		Mumbai	
		Z	P	Z	P
1951–1980	Pre-monsoon	0.0535	0.9573	-0.2855	0.7753
	Southwest monsoon	1.5700	0.1164	-2.2123	0.0269
	Post monsoon	-0.8385	0.4017	-0.0357	0.9715
	Winter	-0.7850	0.4325	1.0883	0.2765
	Annual	1.1775	0.2390	-2.3907	0.0168
1981–2004	Pre-monsoon	-1.0666	0.2862	1.6619	0.0965
	Southwest monsoon	0.1984	0.8427	1.0914	0.2751
	Post monsoon	-0.4961	0.6198	-1.2154	0.2242
	Winter	0.4217	0.6733	0.0744	0.9407
	Annual	-0.3225	0.7471	0.7193	0.4719
1951–2004	Pre-monsoon	0.0821	0.9346	-0.1343	0.8932
	Southwest monsoon	-1.3205	0.1867	-3.2751	0.0011
	Post monsoon	-1.3578	0.1745	0.0895	0.9287
	Winter	0.5222	0.6015	1.1265	0.2599
	Annual	-1.5070	0.1318	-3.4765	0.00050791

values in bold are statistically significant at the 0.05 level

Table 4 Man-Kendall statistics for maximum precipitation trends per year for the two stations and different time spans

Data period	Delhi		Mumbai	
	Z	P	Z	P
1951–1980	-0.5709	0.5681	-1.9982	0.0457
1981–2004	-0.9178	0.3587	1.4139	0.1574
1951–2004	-2.4619	0.0138	-1.7457	0.0809

values in bold are statistically significant at 0.05 level

and precipitation at these two stations. The first two modes of PCA are analyzed as they are the ones that can most easily be associated to physical phenomena. Figure 5 gives

the PCA bi-plot and Fig. 6 reveals the time series of these first two modes of PCA with explained variance of 20.41 and 16.85%, respectively.

The precipitation events at the two cities are seen in isolation due to two main factors namely: the geographic location of the cities, and difference in precipitation variability. As suggested by Goswami et al. (2006) the whole of India cannot be taken as one unit to investigate the trends due to large variability. A PCA analysis (Fig. 5) further clarify the differences between precipitation variability in the two sites. Precipitation variability for Delhi is almost totally represented in the first PCA mode (Fig. 5) while the precipitation variability for Mumbai is almost equally represented by the first and the second PCA modes (x and y axis values). Considering that the modes are orthogonal, there is a large part of the precipitation variability that is diverse in the two regions and that deserves to be analysed separately.

As it can be observed from Fig. 5 that rainfall variability in Delhi is closely related to SCA, EA/WR and PDO as they are mostly represented in the first mode of the PCA. It can also be observed that it has a direct relation to SCA and EA/WR and inverse with PDO as it is directly opposite to variability of rainfall in Delhi in the first mode. The variability in precipitation for Mumbai can be associated inversely with NINO3.4, IOD and EA in the second mode of PCA in agreement with some previous findings (Roy 2006). It can also be observed the clear difference in precipitation variability in these two cities, as precipitation in Delhi is mainly represented in the first mode and that of Mumbai, in the second mode of PCA. The time series of the first PCA mode (Fig. 6a) shows the typical phase change presented in Delhi’s precipitation during Southwest monsoon (Fig. 2c) as well as in the SCA, EA/WR and PDO time series (average values for the same season). Similar changes can be observed for Mumbai.

Figure 6a shows the time series of the first mode of PCA; climatic indices SCA, EA/WR and PDO (as in biplot for first mode) show a close relation to precipitation variability for Delhi as presented in Fig. 3c. Precipitation for

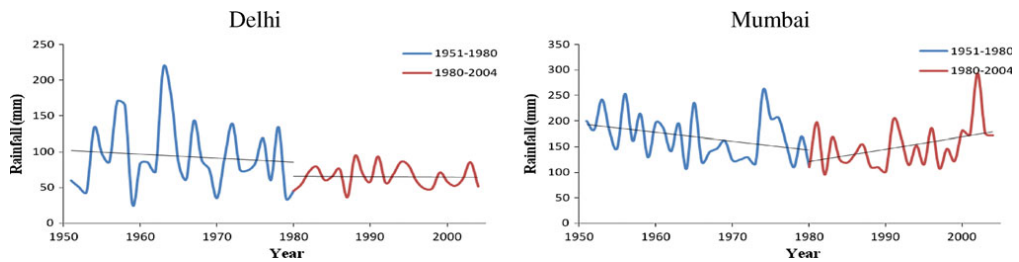

Fig. 4 Maximum daily rainfall per year at the two stations during 1951–1980, 1981–2004 and 1951–2004

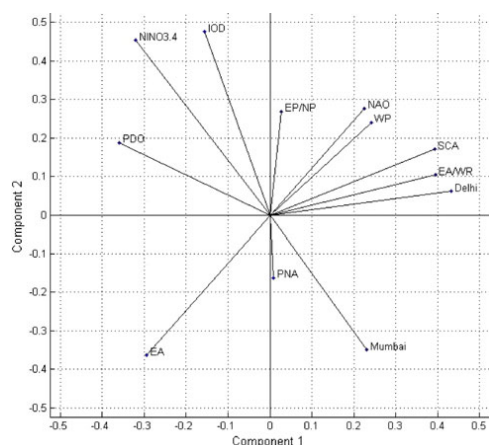

Fig. 5 Bi-Plot from the first four modes of PCA

Delhi in Southwest monsoon season follows the same trend as for the climatic indices. These climatic variables are changing phase of variability in around 25–30 years from starting data period i.e. 1975–1980 (climate shift phenomena) which is clearly indicated for southwest monsoon precipitation for Delhi (Fig. 3c) which is also changing phase in around that period. Also in Fig. 6b, that shows the time series of the second mode of PCA, a close relationship with precipitation for Mumbai is clear (in accordance to Fig. 3c). These indices are also experiencing climate shift

phenomena around 1975–1980 as for the variability for Mumbai precipitation (Fig. 3c). The PCA analysis performed provides strong evidences of the relationship between monsoon precipitation at these stations and climatic phenomena and it clearly shows that monsoon precipitation in Delhi and Mumbai are mainly related to the variability of different climate phenomena. To further strengthen the findings of PCA we plot the standardised data for these stations against the standardised data of related climatic indices in Fig. 7. This is done for visual interpretation of the results and similar findings can be observed in the figure. Visually, the relationship between precipitation and climatic indices is very clear. It can be observed from the figure that for Delhi the precipitation is in direct relation to EA/WR and SCA and inversely related to PDO, when during the period 1975–1980 the climatic indices experience climate shift phenomena; the effect for the same can be easily observed on the precipitation in accordance to the relation. The same can be said for Mumbai’s precipitation which is indirectly related to EA, IOD and NINO 3.4. The climate shift phenomenon is evident from the figure and has been documented by many authors namely Baines and Folland (2007); which has clear indications on the precipitation change during that period.

SVD was applied to the cross-covariance matrix between the average southwest monsoon precipitation per year (June to September) of Delhi and Mumbai and the average of climatic indices for the same season from 1951 to 2004. The two first modes of SVD were considered for

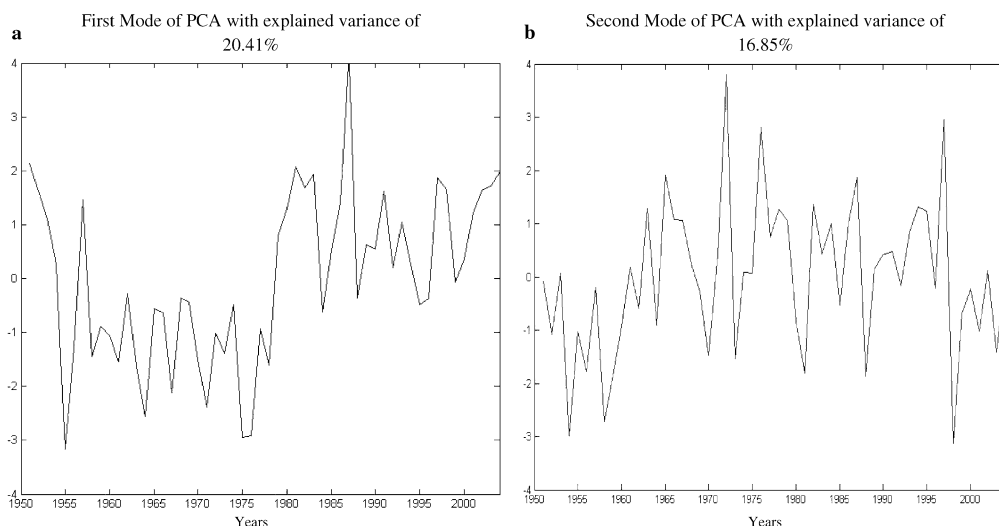
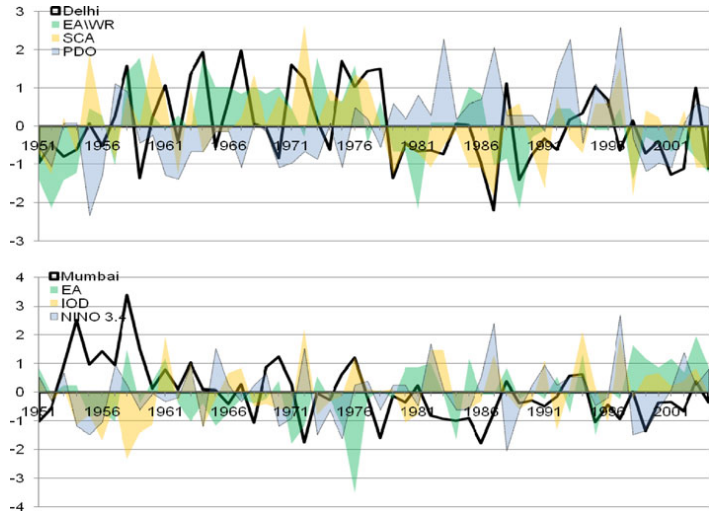

Fig. 6 Time series with explained variance in each mode of PCA analysis for monsoon rainfall and climatic indices

Fig. 7 Comparison of precipitation with related climatic indices



analysis as depicted in Fig. 8. It shows the time series of predictor and predictant over the period of time. They explain, respectively, 61% and 38% of the variance of the original data, which accounts for almost 99% of variability explained. So we can say that the variability in precipitation at these stations is mainly due to global climate phenomena and very less due to local factors as it accounts for 99% of it. Squared covariance fractions for these modes are 72.26 and 27.73%, respectively. Figure 8 depicts time series of the first two modes of the SVD. The correlation

between the time series for each field in the first and second mode is 0.52 and 0.41, respectively.

Heterogeneous correlation table (Table 5) was examined to seeking the relationship between different climate indices with rainfall at the two stations. It can be observed from Fig. 8a, where first mode of SVD is depicted, that the predictand field (precipitation for both stations) is closely related to predictor field (climate indices). From Table 5 it is noticeable that the precipitation in both stations is positively related to EA/WR, SCA, and negatively related to

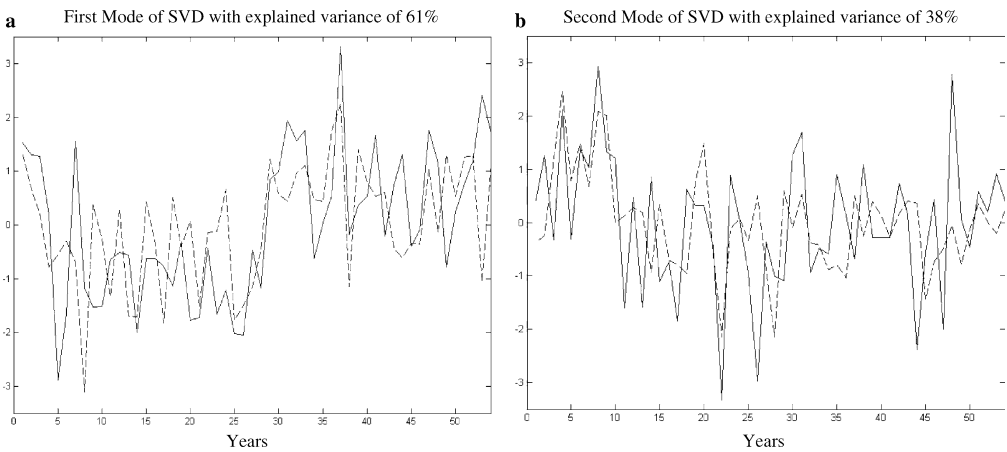

Fig. 8 Time series of predictor (monsoon rainfall) and predictant (climatic indices) in first two modes of SVD with correlation coefficients

Table 5 Heterogeneous correlation table of monsoon total rainfall and climatic indices

S. No.	Delhi	Mumbai	NAO	EA	WP	EP/NP	PNA	EA/WR	SCA	IOD	PDO	NINO3.4
Mode 1	-0.49	-0.29	0.01	0.20	-0.14	-0.05	-0.09	-0.35	-0.34	0.16	0.25	0.33
Mode 2	-0.19	0.32	-0.23	0.12	-0.12	-0.09	0.13	-0.05	-0.11	-0.39	0.00	-0.07

Values in bold are statistically significant at the 0.05 level

PDO and NINO3.4, of all the climatic indices, with Delhi having a dominating effect. The second mode in Table 5 evidences the negative relation of the precipitation in Mumbai with NINO3.4 and IOD.

The result of SVD confirms the relationship between precipitation and climatic variables in the global scenario accounting for most of variability observed in precipitation. There is marked effect of these variables in precipitation of these two cities and different variables have different effect on precipitation. Results from the SVD analysis strengthens and detailed the ones obtained from PCA.

These aspects of variability of precipitation with climatic phenomena are interesting to study the future models that can be developed for long term prediction of rainfall at these stations as the global climate phenomena seem to explain great part of variability in precipitation.

4 Conclusions

An important aspect of the present study is the variability of trends in precipitation that are observed at Delhi and Mumbai. The analysis revealed an insignificant decrease in southwest monsoon rainfall while increase in winter and pre-monsoon season over Delhi for the whole period. That suggests a tendency of a slight spread of the precipitation throughout the year during the period 1951–2004, however without statistical significance. For Mumbai, significant negative changes for long term rainfall were detected for different seasons and for the whole year in the 1951–2004 periods. Trends in southwest monsoon precipitation for both Delhi and Mumbai were shown to be related to the variability of climatic indices. Southwest monsoon precipitation at Delhi is related to SCA, EA/WR and PDO whereas at Mumbai is related to IOD, NINO 3.4 and EA. There is clear indication of decadal shift in precipitation pattern with climatic indices in these two cities.

In concern to daily rainfall, statistical analysis has revealed significant decrease in maximum daily rainfall per year at both the stations along with decrease in average maximum rainfall in a day. Most of the rainfall at both the stations was found to be taking place in southwest monsoon season with greater variability for Mumbai than Delhi. All trends identified in this work can be related to some findings by other authors namely Kumar et al. (1992) where they

have found significant increasing trend in monsoon seasonal rainfall along the west coast, north Andhra Pradesh and northwest India while significant decreasing trends over east Madhya Pradesh and adjoining areas, north-east India and parts of Gujarat and Kerala. Similar studies have been done by Goswami et al. (2006) for trend analysis on different areas in India than Delhi and Mumbai.

These relationships might prove useful in prediction of rainfall for these urban centres that will prove handy in planning and management. Finally there is a need to incorporate climate variability in the planning and management of water resources of these cities. This study provides subsidies, which may be used for sensitivity analysis of water availability in Delhi and Mumbai. Although there are uncertainties about the magnitude and direction of future climate variation at various places, measures must be initiated to minimize the adverse impacts of these changes on society and resources.

References

- Bainnes PG, Folland CK (2007) Evidence for a rapid climate shift across the late 1960s. *J Clim* 20:2721–2744
- Bretherton CS, Smith C, Wallace JM (1992) An intercomparison of methods for finding coupled patterns in climate data. *J Climate* 5:541–560
- Chhabra BM, Prakasa Rao GS, Joshi UR (1997) A comparative study of differences in the averages of temperatures and rainfall over the Indian stations during the periods 1931–1960 and 1961–1990. *Mausam* 48(1):65–70
- De US, Dandekar MM (2001) Natural disasters in urban areas. *Deccan Geographer* 39:1–12
- del Rio S, Penas A, Fraile R (2005) Analysis of recent climatic variations in Castile and Leon (Spain). *Atmos Res* 73:69–85
- Dymnikov VP, Filin SK (1985) A study of the correlations between sea-surface temperature anomalies in mid-latitudes and anomalies in heating, based on data from the first GARP Global Experiment. Reprint of the Department of Numerical Mathematics of the U.S.S.R Academy of Sciences
- Fukoka A (1951) A study on 10 day forecast (a synthetic report). *Geophys Mag* 22:117–208
- Gadgil A, Dhorde A (2005) Temperature trends in twentieth century at Pune, India. *Atmos Environ* 39:6550–6556
- Goswami BN et al (2006) Increasing trend of extreme rain events over India in a warming environment. *Science* 314(5804):1442–1445. doi:10.1126/science.1132027
- Guhathakurta P, Rajeevan M (2006) Trends in the rainfall pattern over India. NCC Research Report No 2/2006. *National Climate Centre*. India Meteorological Department, pp 23

- Holmstrom I (1963) On a method of parametric representation of the atmosphere. *Tellus* 15:127–149
- Jagannathan P, Bhalme HN (1973) Changes in pattern of distribution of southwest monsoon rainfall over India associated with sunspots. *Mon Weather Rev* 101:691–700
- Joseph PV, Xavier PK (1999) Monsoon rainfall and frequencies of monsoon depressions and tropical cyclones of recent 100 years and an outlook for the first decades of 21st Century. *Meteorology beyond 2000*. In: Proceedings of Indian Meteorological Society. TROPMET-99, pp 364–371
- Joshi UR, Rajeevan M (2006) Trends in precipitation extremes over India. Research report No 3/2006. National Climate Centre. Indian Meteorological Department
- Katzbach J (1967) Empirical eigenvectors of sea-level pressure, surface temperature and precipitation complexes over North America. *J Appl Meteor* 6:791–802
- Koteswaram P, Alvi SMA (1969) Secular trends and periodicities in rainfall at west coast stations in India. *Curr Sci* 101:371–375
- Kumar JR, Dash SK (2001) Interdecadal variations of characteristics of monsoon disturbances and their epochal relationships with rainfall and other tropical features. *Int J Climatol* 21:759–771
- Kumar K, Pant GB, Parthasarathy B, Sontakke N (1992) Spatial and sub-seasonal patterns of the long-term trends of Indian summer monsoon rainfall. *Int J Climatol* 12:257–268
- Lanzante JR (1984) A rotated eigen-analysis of the correlation between 700-mb heights and sea surface temperatures in the Pacific and Atlantic. *Mon Wea Rev* 112:2270–2280
- Lorenz EN (1956) Empirical orthogonal functions and statistical weather prediction. *Sci. Rep. No. 1*. Statistical Forecasting Project. Department of Meteorology. Massachusetts Institute of Technology
- McCarthy JJ, Canziani OF, Leary NA, Dokken DJ, White KS, (eds) (2001) In: Climate change- impacts, adaptations and vulnerability. Inter-governmental panel on climate change (IPCC) report
- Mitchell JM Jr, Dzerdzevskii B, Flohn H, Hofmeyr WL, Lamb HH, Rao KN, Wallen CC (1966) Climate change. World Meteorological Organisation. Technical note no 79. WMO 195. TP 100. Secretariat of WMO. Geneva, Switzerland
- Mooley DA, Parthasarathy B (1984) Variability of Indian summer monsoon rainfall and tropical circulation features. *Mon Weather Rev* 111:967–968
- Naidu CV, Rao BRS, Rao DVB (1999) Climatic trends and periodicities of annual rainfall over India. *Meteorol Appl* 6:395–404
- Obukhov AM (1960) On statistical orthogonal expansions in empirical functions. *Izvest Geophys Ser (Eng. Trans)* 5:288–291
- Pant GB, Bargaonkar HP (1984) Climate of the Hill regions of Uttar Pradesh. *Himal Res Dev* 3:13–20
- Pant GB, Rupa Kumar K, Bargaonkar HP (1999) Climate and its long-term variability over the Western Himalaya during the past two Centuries. In: Dash SK, Bahadur J (eds) *The Himalayan environment*. New Age International (P) Limited Publishers, New Delhi, pp 171–184
- Parthasarathy B (1984) Inter annual and long term variability of Indian summer monsoon rainfall. *Proc Indian Acad Sci (Earth Planet Sci)* 93:371–385
- Parthasarathy B, Kumar KR, Munot AA (1993) Homogeneous Indian monsoon rainfall—variability and prediction. *Proc Indian Acad Sci Earth Planet Sci* 102:121–155
- Pearson K (1902) On lines and planes of closest fit to system of points in space. *Philos Mag* 6:559–572
- Pramanik SK, Jagannathan P (1954) Climate change in India—1: rainfall. *Indian J Meteorol Geophys* 4:291–309
- Prohaska J (1976) A technique for analyzing the linear relationships between two meteorological fields. *Mon Wea Rev* 104:1345–1353
- Rao KN, Jagannathan P (1963) Climate change in India—1. In: Proceedings of symposium on changes in climate. UNESCO and WHO, Rome, pp 49–66
- Roy SS (2006) The impacts of ENSO, PDO, and local SSTs on winter precipitation in India. *Phys Geogr* 27:464–474
- Singh OP (2001) Multivariate ENSO index and Indian monsoon rainfall: relationships on monthly and subdivisional scales. *Meteorol Atmos Phys* 78:1–9
- Singh N, Sontakke NA (1999) On the variability and prediction of rainfall in the post-monsoon season over India. *Int J Climatol* 19:309–339
- Srivatsava HN, Dewan BN, Dikshit SK, Prakasa Rao GS, Singh SS, Rao KR (1992) Decadal trends in climate over India. *Mausam* 43:7–20
- Thapliyal V, Kulshrestha SM (1991) Climate changes and trends over India. *Mausam* 42:333–338
- Tomozeiu R, Pavan V, Cacciamani C, Amici M (2006) Observed temperature changes in Emilia-Romagna: mean values and extremes. *Clim Res* 31:217–225

Appended paper

III

Bengtsson, L. and Rana, A. (2013) Long-term change of daily and multi-daily precipitation in southern Sweden. *Hydrological Processes*. DOI: [10.1002/hyp.9774](https://doi.org/10.1002/hyp.9774)

Long-term change of daily and multi-daily precipitation in southern Sweden

Lars Bengtsson* and Arun Rana

Department of Water Resources Engineering, Lund University, Sweden

Abstract:

Daily rain series from southern Sweden with records dating back to the 1870s have been analysed to investigate the trends of daily and multi-day precipitation of different return periods with emphasis on the extremes. Probabilities of extreme storms were determined as continuously changing values based on 25 years of data. An extra set of data was used to investigate changes in Skåne, the southernmost peninsula of Sweden. Another 30-year data set of more than 200 stations of a dense gauge network in Skåne was used to investigate the relation between very large daily rainfall and annual precipitation.

The annual precipitation has increased significantly all over southern Sweden due to increased winter precipitation. There is a trend of increasing maximum annual daily precipitation at only one station, where the annual maximum often occurs in winter. The number of events with a short return period is increasing, but the number of more extreme events has not increased. Daily and multi-daily design storms of long return periods determined from extreme value analysis with updating year by year are not higher today than during the last 100 years. The largest daily storms are not related to stations with annual rainfall but seem to occur randomly. Copyright © 2013 John Wiley & Sons, Ltd.

KEY WORDS daily precipitation; multi-day rains; extreme events; annual events; long-term records; trends; southern Sweden

Received 27 April 2012; Accepted 7 February 2013

INTRODUCTION

The intention with the present paper is to investigate how the precipitation in the south of Sweden has varied over long periods and see whether trends are present when the studied period is extended over long times. Daily and multi-daily rains are investigated. Distinction is made between large events and extreme events. Using a large data set, relation between different large events and annual precipitation is sought. The daily precipitation data analysed in the paper are divided into three groups. The first group constitutes data from nine stations, with most of the records extending back to the 1870s. These stations are meant to represent different parts of southern Sweden. For the Skåne Peninsula, nine stations with data since 1961 are chosen, representing only the southernmost part of Sweden. The last selection of data is from more than 200 stations from Skåne, with records from 1961 to 1990,

which are used to relate large events to local annual precipitation. No attempt to forecast future precipitation intensities is made.

The annual precipitation in southern Sweden has increased over the last 100 years because of increased winter precipitation (e.g. Dahlström, 2006), which is also shown for the stations used in this study further down in the text. Investigating 75 series from Europe of 100 years' data, Moberg *et al.* (2006) found that the total winter precipitation has increased and also the large daily winter rains. Results from regional climate models point at a further increase in the annual as well as the extreme precipitation (Räisänen and Joëlsson, 2001). In many regions of the world with climate not so different from southern Sweden, there seems to have been an increase in the winter precipitation at least when considering only the last 50 years. Kveton and Zak (2008) report increased annual precipitation for the Czech Republic over the last 100 years, but when extending the data series for another 100 years, there is no trend. When analysing precipitation data for the entire 20th century, Trömel and Schönwiese (2007) found that the annual precipitation had increased in southern Germany and decreased in the east but showed no clear change in the west. However, they could conclude that the variation of annual precipitation between years had increased. It is clear that when trends are investigated, the choice of period is important. It may be

*Correspondence to: Lars Bengtsson, Department of Water Resources Engineering, Lund University, Sweden
Email: Lars.Bengtsson@TVRLLTH.se

*Correspondence to: Lars Bengtsson, Department of Water Resources Engineering, Lund University, Sweden
Email: Lars.Bengtsson@TVRLLTH.se

possible to find trends in different directions for different periods if the investigated period is short.

As a consequence of the atmospheric temperature increase, the water holding capacity of the atmosphere is also increasing, which ought to result in more intense short-term storms (e.g. Trenberth *et al.*, 2003; Trenberth, 2011), even when the annual precipitation does not increase. With more humidity in the atmosphere, there may be a shift so that more of the large rains are created by convective mechanisms than as today. Analyses of changes in climate extremes with coupled atmosphere–ocean general circulation models have been performed in many studies. These experiments indicate larger changes in extreme precipitation compared with changes in mean precipitation (e.g. Kharin and Zwiers, 2000; Semenov and Bengtsson, 2002). Generally, the return periods of rains of certain intensities are expected to become shorter (e.g. Hennessy *et al.*, 1997; McGuffie *et al.*, 1999). Hennessy *et al.* (1997) found that doubling the carbon dioxide in the atmosphere ought to increase the intensity of the one-year daily storm by 10–25%. For the countries around the Baltic, the modelling results of Semmler and Jacob (2004) point to a doubling of the extreme rain intensities. With downscaling technique, Skaugen *et al.* (2003) computed the extreme daily precipitation to increase by 10–50% in large parts of Norway. Later, for northern Europe, Haugen and Iversen (2008) downscaled the rains simulated from eight different global circulation models (GCMs) and many greenhouse gas scenarios and estimated the annual maximum daily rainfall. The result varied very much for the different combinations, but the conclusion was that the annual maximum daily rainfall will increase. Kao and Ganguly (2011) used temperature from regional climate models as input to a conceptual physical relationship (basically Clausius–Clapeyron) to show how precipitation extremes will increase over time. Dahlström (2006) used a similar but more analytical approach for Sweden to come to the same result and was even able to relate the storms to duration and return periods. However, these theories are best related to convective storms. The largest daily rains in Sweden most often extend over a large part of the day and are of frontal character even when they tend to occur in the summer.

Although GCMs and regional models are required in forecasting future conditions, ongoing changes are maybe better found from observational records. There are many daily precipitation series extending 100 years or even 200 years back in time. Many investigators have analysed these long data records. In that respect, it should be pointed out that it is difficult to find trends of the most extreme events, since there are only few of them. Therefore, events with a return period of several years are seldom looked for; attention is instead focused on moderate events with a return period of two to five times per year or on the annual daily

maximum intensity. Often if the data series are extended over a long time, different periods of high rain intensities and of low intensities can be detected, and trends over time may disappear.

Förland *et al.* (1998) found an upward trend over the 20th century in the annual maximum 1-day precipitation amounts over Nordic countries. There have been many studies of British daily precipitation records from 1961 to 1995 (e.g. Osborn and Hulme, 2002; Fowler and Kilsby, 2003). They all show that the winter rains have become more intense but that the daily summer storms have decreased in intensity. Maraun *et al.* (2008) updated the results up to 2006. From the prolonged time series, it is seen that the trend of increased winter rain intensity has not continued at the rate reported for 1961–1995. For summer, the intensities turned back towards the 1961–1995 reference being more consistent with interdecadal variability than with an overall trend. This shows the difficulties in interpreting trends.

For the German part of the Rhine basin, Hundecha and Bárdassy (2005) investigated the daily extreme precipitation measured in more than 600 gauges from 1958 to 2001. The daily heavy precipitation has showed increasing trends in magnitude and frequency in all seasons except summer, where it has showed the opposite trend. The 90th percentile of daily precipitation was used as an index, which is a modest rain. Also, in Switzerland, the winter rains have been found to have increased (Schmidli and Frei, 2005). Here, no trend of changed high summer storms was reported. When investigating Belgium records from 1910 and onwards, Gellens (2000) did not find any change of the daily intensities.

Moberg and Jones (2005) analysed full 20th century trends of rather moderate precipitation extremes calculated from daily observational data for 80 central and western European stations. Significant increasing precipitation trends dominate in winter for moderately strong events. The summer intensities did not seem to have changed through the 20th century. In a follow-up paper, Moberg *et al.* (2006) could not find any significant trends of increased intensities, but they found non-significant increasing trends in the 90th to 98th percentiles.

Further east in Europe, Kveton and Zak (2008) investigated extreme precipitation events in the Czech Republic from 1895. They found no increase in the single station country daily maximum or in the station mean daily maximum. The mean annual maximum daily rainfall is about 40 mm, which would correspond to maybe a 4-year storm in southern Sweden. Lupikasza (2009) investigated precipitation magnitudes in Poland for the period 1951–2006 using daily data from 48 stations. Decreasing trends in 5-day precipitation, precipitation intensity of the 90th and 95th percentile events and number of days with precipitation corresponding to these percentiles dominated in both winter and summer seasons.

Hägström (2001) investigated events in Sweden exceeding 40 mm/day, which are events of 2- to 5-year return period and thus a rare event compared with those of most other statistical studies. The part of stations in Sweden for which such high daily precipitation is observed is about 25% every year. There has been no change in the period from 1920 to 2000. Most of these large rainfall events occur during cyclonic weather conditions (Hellström, 2005).

Madsen *et al.* (2009) analysed short-term storms in Denmark in 1980–2005. They determined the storms of different return periods and found that storms with durations of minutes and hours had increased over the period, most so the storms of long return periods. The daily storms had, however, not increased. Although the statistically estimated storms of 1–2 h duration were shown to have increased as much as 20%, the change is not statistically significant.

For Canada, with a not so different climate from that of Sweden, Zhang *et al.* (2001) investigated daily rainfalls with a return period of 20 years for the entire 20th century but found no long-term trend. The observed increase in annual precipitation is due to an increase in the number of small and moderate rain events. There have been a number of studies investigating trends of heavy precipitation in the USA. These studies are well summarized in the many publications by Kunkel and co-workers (e.g. Kunkel *et al.*, 2003). The studies cover precipitation in many different climates. The studies show a trend of increasing number of extreme events for the period from 1920 onwards, but when Kunkel *et al.* (2003) included data for the late 1800s and early 1900s, the trend was not found to be significant. Later, looking at the data in more detail, accounting for the effects of missing data and the less dense station network in the early period, Kunkel *et al.* (2007) also found a trend for the full period. This example shows that trend analysis must be performed with care.

Not only the regional or local annual precipitation and the large rains may change, but the movement pattern of the frontal rains may also change so that the spatial distribution of the large rains will change. Mishra and Singh (2010) found when analysing extreme daily precipitation in Texas in the period 1925–1965 (which they call the pre-climate change period) and the period 1965–2005 (called the post-climate change period) that decreasing and increasing patterns appeared at different locations during the pre- and post-climate change periods.

In Sweden, annual precipitation or summer precipitation are often used in combination with short-term rain intensities from other sites for determining design storms of moderate return periods (Dahlström, 1979). For Denmark, Madsen *et al.* (1998) found that a large part of the variability of the number of large events at different stations could be explained by the mean annual rainfall. Recently, Madsen *et al.* (2009) updated this investigation using new data for the period 1997–2005, deriving new intensity–frequency–duration

curves for Denmark. The new study supported the previous findings that the regional variability of large rainfalls is partly explained by the annual precipitation. However, the very extreme events in southern Sweden seem to be spatially randomly distributed, with little relation to annual mean precipitation. Bengtsson (2011) showed using daily precipitation observations from a 200-station network, data that are also used in this study, that the most extreme events could not be related to annual precipitation.

DATABASE

As already mentioned, the precipitation data used in this paper are divided into three groups. In the first group, there are data from nine official Swedish Meteorological and Hydrological Institute (SMHI) stations. The stations are shown in Figure 1. For seven of these stations, the records extend back to the 1870s or 1880s; for two of them, the records go back only to 1920. The stations are meant to represent different parts of southern Sweden. The records are close to or, for most of the stations, considerably longer than 100 years. Data after 1961 are from the digital database of SMHI. Data prior to that have been digitalized from books. For some of the stations for the period 1931–1960, the new database derived from books includes monthly sums and all days with large rains (daily precipitation > 15 mm), but not days with only little precipitation.

The records in the second group from the nine SMHI stations (also shown in Figure 1) representing only the Skåne



Figure 1. Position of precipitation stations with long records. Stations with very long records are given with full names. Stations with 50-year records are shown as small circles and not with full names. Hbg denotes Helsingborg, Tbg is Trelleborg, Sjö is Skurup, T is Tomelilla and B is Brösarp

Peninsula are 50 years long. The last selection of data is from 229 stations from Skåne, with records from 1961 to 1990. The positions of the stations are shown in Figure 2. The Skåne precipitation network was established by Hon. Dr. Jan Ellesson and herein referred to as the Ellesson data (Ellesson and Persson, 1961). SMHI gauges were used also in this precipitation network. These data were digitalized from Ellesson's notes. The long-term data are used for trend analysis, while the data from the dense Ellesson network here are used to find relations between annual precipitation and rain events.

Skåne is the southernmost peninsula of Sweden. The biggest city in Skåne is Malmö situated, in the south-west. The stations outside Skåne are chosen to get a wider picture of the precipitation conditions of southern Sweden. These stations are Halmstad and Göteborg on the west coast north of Malmö, Borås and Växjö on a 150–200-m-high plateau, and Kalmar, which is on the east coast, all shown in Figure 1. The distance between Malmö in the south-west and Göteborg in the north-west is about 300 km. Borås is situated about 100 km east of Göteborg. In the easternmost part, Kalmar is 200 km east and 150 km north of Malmö. The annual precipitation is by far the largest in Borås, about 1000 mm, followed by that in Göteborg and Halmstad, which is about 750 mm. The difference in annual precipitation is mostly due to different winter precipitation in the different cities. The frontal rains are usually coming from the west. Only some tens of kilometres east of Halmstad, there is a high plateau. Växjö is situated on this plateau about 100 km east of Halmstad. The western frontal rains have lost much of their precipitation when reaching Kalmar in the east coast. The annual precipitation is the lowest there, about 500 mm.

For all the nine stations of 50-year records on the Skåne peninsula, the meteorological conditions are similar. The

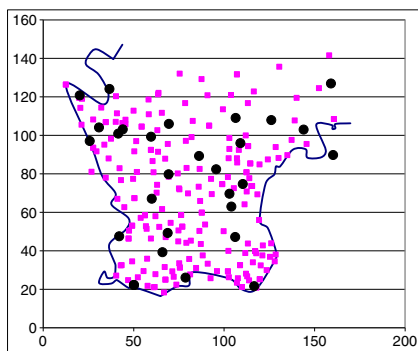

Figure 2. The Ellesson precipitation gauge network with observations from the period 1961–1990 (small squares) and stations where annual regional daily maximum was observed in that period. The coordinates (scale) are in kilometres

annual precipitation is 550 to 650 mm. All these stations are situated at a low level, below 40 m.

The Ellesson data from 229 stations cover an area of almost 10 000 km². The station density is about one station per 40 km². For 90 of the stations, the series are complete or almost complete, covering 28–30 years. Within the Skåne peninsula, there are five ridges with an elevation of 100–200 m. At these stations, the annual precipitation is much higher than at the lowland. The annual precipitation at the 229 Ellesson stations varies between 450 and 1000 mm. Figure 2 also shows where the maximum daily precipitation has been observed in the 30-year period. This is at 28 different stations. The annual precipitation is low at some of these stations. The Ellesson data network is described in more detail by Bengtsson (2011). The data are used to find relations between large daily rains and annual precipitation.

Daily rains are not intense in Sweden. There are only 30 official observations in the whole of Sweden, with daily precipitation exceeding 120 mm. The highest daily rain amount from the stations under investigation in this paper is close to 150 mm from Växjö in 1945. The second highest, including also the Ellesson station network, is less than 120 mm. From the official SMHI records, the second highest is 100 mm. The daily annual maximum precipitation is within a rather narrow range for most of the stations, about 30–35 mm. A daily storm of 40 mm/s is considered an extreme storm by SMHI. Such events are not common in southern Sweden, having a return period of 2–5 years. Since there seems to be a relation between the more common storms and annual precipitation but a less clear relation between the more extreme rains and annual precipitation, the statistics of the modest rains are treated separately from the extreme rains.

The paper is structured so that after a short section about the used statistics, trends of annual precipitation are first investigated, and then large daily rains with return period up to a year are analysed, followed by an analysis of the extreme daily rains of long return periods. Trends over more than 100 years are investigated. Comparison is also done between rains in different about-30-year-long periods. After the daily rains, multi-day rains are investigated. Finally, the Ellesson data is used to find relations between large and extreme rains and annual precipitation.

STATISTICS

Trends over time were analysed using the non-parametric Mann–Kendall test and also linear regression with *t*-test. Trends were considered significant at the 2.5% level (5% double-sided) and weakly significant at the 5% level (10% double-sided). The results from the trend tests are marked in the summarizing tables. Significance is

indicated with a * or ° in the tables. Most often, trends were found either for both the trend tests or not at all. When the two tests gave different results, it is indicated below the tables. Trend tests were done on rain amounts and also on the number of events exceeding certain values. For events with a frequency of less than one per year, a trend analysis was performed on the number of events per decade. The probability of the exceedance of a certain event was determined simply from the number of events in a given period.

The return period of events of low return period was simply found from the ranking position of that event (a procedure also used by Kunkel *et al.* (2003)). Thus, when 100 years of data was used, the 0.5-year return period was taken as the event with ranking number 200 (the mean of three numbers around rank 200 was taken). For the more extreme events, the annual maximum of each year was used in the statistical analysis applying General Extreme Value (GEV) or Gumbel distribution and also using the peak over threshold (POT) approach with Pareto distribution (e.g. Rosbjerg *et al.*, 1992), including n events in the whole period, with $n=0.4$ * number of years in the series. L-moments were used for parameter estimation. Thus, as an example, with 100 years of data, the 40 largest ones are included. The ranking position was as suggested by Rosbjerg (1988), chosen as $(i-a)/(N+b)$, where i is the position and N is the number of included observations, with $a=0.35$ and $b=0.4$.

The return periods were computed using the full data set at a station (from ranking position for not very long return periods and for long return periods from the probability distributions) but were also computed as moving (changing) values over time. Return periods were determined consecutively year after year, assuming that only the previous 25 years of data were available. For example, for 1990, values for 1966–1990 were used, and for 1991, values from 1967–1991. This is how return

periods would have been determined when only 25 years of observations were available.

The relation between annual rainfall and daily rainfall was determined from simple linear regression followed by t -test. Tests for differences in means for different periods were performed with t -test, assuming two normal distributions. The samples are large, so the central limit theorem enables the use of such tests also for non-normal samples. Account was taken of the different lengths of the observation data in different periods.

ANNUAL PRECIPITATION

Although the intention is to analyse large daily and multi-daily rains, it seems reasonable to start with a short analysis of the annual and seasonal precipitation and eventual trends. At all the nine stations with very long data records, the annual precipitation has increased over the last 100–135 years, which is clear from the trend values given in Table I. The trends are significant at the better-than-1% level. The precipitation has increased by about 20%. The increase is strongest for Borås, 1.8 mm/year, where the annual precipitation also is the largest. The increase corresponds to almost 25%. As shown later in the text, the winter precipitation has increased, but the summer precipitation has not. For all of the nine cities, the annual increase has been faster the last 50 years than the mean increase rate over the whole period. Comparisons between different periods are shown in the table. The increase over the last 50 years, since 1961, is especially strong in the two cities Halmstad and Göteborg on the west coast, where the increase of the precipitation is almost 5 mm/year, which is a 30% increase in 50 years. The variation of the annual precipitation, including the trend line, is shown for Göteborg in Figure 3. The trend since 1961 is also shown. The steep trend of increasing precipitation over these last 50 years is explained by low

Table I. Mean annual precipitation (in millimetres) and trend (in millimetres per year) for the major cities with long records for the whole observation periods and for different periods

	Lund	Malmö	Krist	Karlsk	Halm	Kalmar	Växjö	Gtbg	Borås
Start year	1873	1921	1878	1873	1873	1875	1920	1873	1884
Full period	630*	550*	560*	564*	752*	465*	650*	760*	940*
Start–1930	610 [†]		530*	535*	716	435*		745	894 [†]
1931–1960	597	535	575	558	756	465	650	670	897 [†]
1961–2011	670	580*	583*	597	796*	500*	675*	828*	1014*
Ann trend	0.66	1.2	0.8	0.8	1.0	0.9	0.8	1.0	1.8
Start–1930	0.78		2.0	2.1	–0.8	2.0		–0.7	2.6
1931–1960	1.25	–0.4	–0.75	–0.8	0.2	–1.4	2.9	1.2	6.0
1961–2011	0.25	2.2	1.78	1.0	4.5	1.8	2.3	4.9	3.8

*Significance level 2.5% (5% double-sided) or better.

[†] Weak significance better than 10% (double-sided).

Gtbg denotes Göteborg, and Krist is Kristanstad. Details about the methods are given in the Section on Statistics.

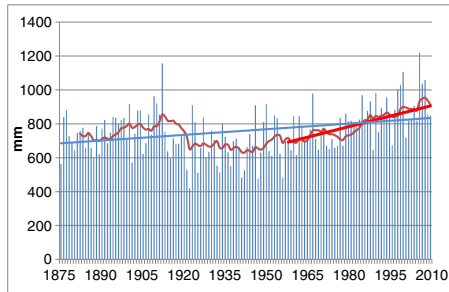

Figure 3. Annual precipitation in Göteborg with 10-year moving average, trend line for the whole period and the trend from 1961

annual precipitation in the mid-1900s. It is seen from the moving 10-year average that the annual precipitation is the highest at present, but that it was high also at the turn of the previous century. An old study by Ångström (1941) indicates that the precipitation was very high in the 1860s. Details about annual change of precipitation are shown for all the major cities in the study in Table I. In Lund, differently from the other cities, the increase of the annual precipitation has been minor over the last 50 years, only 2%.

Investigating only stations in the southernmost part of Sweden, the region Skåne, with data from 1961 including 2011, the increase of the annual precipitation over the last 50 years is significant at the 1% level for seven of the nine stations. For these seven stations, the increase is almost 20% over 50 years. For the other two stations, the increase is, although not significant, 1 mm/year. The data for the Skåne stations are synthesized and given in Table II. Helsingborg is, as Halmstad and Göteborg, situated at the west coast. In the last 50 years, the annual precipitation has increased by almost 30% in these three cities.

An increase of the annual precipitation is consistent with other studies, as was pointed out in the Introduction. It is usually considered that there is an ongoing slight decrease of the summer precipitation in southern Sweden (Dahlström, 2006), although observations show a clear decrease only for August. When analysing monthly precipitation for the nine cities with very long records, no decrease of the summer precipitation is found, nor for the Skåne stations with 50-year records. For all stations and all months, the trends for the

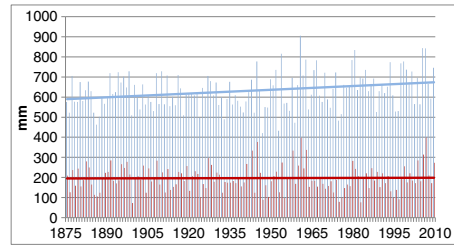

Figure 4. Annual (light coloured vertical bars and trend line) and summer precipitation (dark colour) in Lund with trend lines (no trend for the summer precipitation)

winter and autumn months are significantly positive. There are negative trends for Halmstad and Göteborg for August, but it is compensated for by increased June precipitation, so the total summer precipitation has not decreased. Considering only the period from 1961, there is for most of the Skåne stations a weak increase of the summer precipitation. Still, for the whole period of more than 100 years, it can be concluded that the increase of the annual precipitation can be attributed to the increase of the winter precipitation, as shown, for example, for Lund in Figure 4. While the annual precipitation has increased by about 100 mm over 100 years, the summer precipitation for June–August has been stable.

LARGE DAILY PRECIPITATION

In a warmer climate, it is expected that the convective storms will be more intense. Also, it can be expected that higher annual rainfall will lead to larger daily and multi-daily rains. Large daily storms may be from frontal rains or from convective storms of short duration. Bengtsson and Milotti (2010) have analysed short-term 1-min resolution rainfall in Malmö from data extending back to 1980 and compared with daily precipitation. During 30 years, there have only been 14 events of daily rains exceeding 40 mm. About 50% of these daily rains are attributed to storms of duration of less than 5 h. The daily rains, only four, exceeding 60 mm were all of durations of at least 9 h, indicating that the very large daily rains may be of frontal character. The large storms have all occurred in June through September. All storms of hourly depth exceeding 20 mm are of short duration. The maximum

Table II. Mean annual precipitation (in millimetres) and annual trend (in millimetres per year) at Skåne stations, 1961–2011

	Lund	Malmö	Krist	Karls	Hbg	Tbg	Skurup	Tom	Brsrp
Precip	670	580*	580*	600	650*	540*	680*	680*	630*
Trend	0.25	2.2	1.8	1.0	4.7	2.5	2.1	2.1	4.2

*Significance level 2.5% (5% double-sided).

Hbg denotes Helsingborg; Tbg, Trelleborg; Brsrp, Brösarp.

daily rain from these short events is 44 mm. The largest daily rains (> 40–50 mm) are frontal summer rains. The more modest rains (as accumulated daily volumes) may be of convective character.

If the mean annual maximum daily rain event is to increase proportionally to the increase of the annual rainfall, this maximum should have increased by at least 4–5 mm over 100 years. This is not so in southern Sweden. As briefly shown when the Elleson network was introduced and is treated in more detail later on in this paper, very extreme events cannot easily be related to mean statistics whereas it seems that more modest storms can. Therefore, large storms with a return period of less or slightly more than a year are treated first, followed by the more extreme storms. For all the investigated sites, the annual storm is slightly more than 30 mm/day, except on the ridges within the Elleson network, where there are some stations with an annual daily maximum exceeding 40 mm/day.

In this section, annual mean daily maximum rainfall is treated and also the number of events exceeding 20 mm/day and exceeding 30 mm/day. There is a short discussion about the difference between summer rains and winter rains. The observation data are treated for the full, >100-year-long

period but are also separated into either three periods from the late 1800s (varying between 1873 and 1884) until 1930, the period 1931–1960, and the last period 1961–2011, or divided into four periods, where the last period from 1961 onwards is divided into two periods, 1961–1990 and 1991–2011. As standard, SMHI compares the climate within 30-year periods. Summarized data for the nine stations with very long records are shown in Table III.

The annual daily storm is not very different at the different cities and not between different periods, although it is the highest in Borås, where the annual precipitation is the highest, and lowest in Kalmar, where the annual precipitation is the lowest. There is an increasing trend over the full 130-year-long period in Borås, but not at the other stations. For the shorter period from 1961 onwards, there is a significant trend of increasing annual maximum daily precipitation in Växjö (1.5 mm over the 50-year period). Still, the 1961–2011 mean is much lower, 31.9 mm (when decimals are included), than the mean for the period 1931–1960, 35.7 mm.

Most large events occur in the summer. The mean annual non-summer maximum daily rainfall for Lund is about 20 mm, and the summer mean is 31 mm/day. Since the mean

Table III. Annual daily maximum rainfall and frequency of daily storm exceeding 20 mm, 30 mm and 40 mm for the cities with long records

	Lund	Malmö	Krist	Karlsk	Halm	Kalmar	Växjö	Gtbg	Borås
Annual max									
Start year	1873	1921	1878	1873	1873	1875	1920	1873	1884
Full period	32.4	32.4	33.4	30.8	35.0	29.2	33.3	34.6	36.2*
Start–1930	32*		31	30	34	29		35	34
1931–1960	35	30 [†]	36	31	37	29	36	33	36
1961–2011	32	33	33	31	36	29 [†]	32*	35 [†]	37
<i>P</i> > 20 mm									
Full period	2.6*	2.2 [†]	2.5 [†]	2.5	3.7*	2.0*	2.4	4.3*	6.4*
Start–1930	2.3		2.3 [†]	2.3	3.31	1.7*		4.2	5.4 [†]
1931–1960	2.3	2.2	2.9 [†]	2.8	3.45	1.9	2.4	3.6	5.5
1961–2011	3.0* [†]	2.2*	2.5 [†]	2.5	4.4 [†]	2.1 [†]	2.4*	5.0*	7.8*
1990–2011	3.4*	3.0	3.2	3.0	5.4	2.5	2.9	6.0 [†]	9.2
<i>P</i> > 30 mm									
Full period	0.72*	0.60	0.67	0.55*	1.0 [†]	0.52	0.50 [†]	0.96*	1.43*
Start–1930	0.61		0.67	0.38	0.93	0.60		1.00	0.87
1931–1960	0.80	0.48	0.57	0.67	0.76	0.46	0.50	0.88	1.50
1961–2011	0.82	0.61	0.78	0.69	1.2	0.49	0.64	1.10	1.90
1990–2011	1.05	0.68	0.76	0.77	1.9	0.75	0.65	1.27	2.27
<i>P</i> > 40 mm									
Full period	0.21	0.20	0.22	0.19	0.35	0.16	0.18	0.26	0.40
Start–1930	0.20		0.21	0.14	0.26	0.13 [†]		0.28	0.30
1931–1960	0.27	0.12*	0.27	0.21	0.45	0.29	0.21	0.28	0.46
1961–2011	0.22	0.24	0.22	0.24	0.41	0.14	0.18	0.25	0.46
1990–2011	0.29	0.23	0.28	0.32	0.55	0.26	0.26	0.28	0.45

*Significance level 2.5% (5% double-sided) or better.

[†] Better than 10% (double-sided).

The 40-mm events have not been analysed for trend. The 30-mm events were analysed for trend only for the full investigating period and with number of events per decade. Negative sign next to the trend mark denotes decreasing trend. The sequence of the footnote citations ([†]) is explained in Table 4.

annual maximum is 32 mm/day, it is clear that most of the annual maxima occur in the summer. In Borås, there are more large frontal winter rains than in the other cities but not more very large summer rains. The annual daily maximum occurs almost as often in the winter as in the summer, as shown in Figure 5. The difference between the large daily summer rains and the winter rains is small. The summer mean annual maximum daily rainfall is 29 mm, and the winter mean maximum is 26 mm. In the figure, the trend of increasing daily winter storms is shown. It can also be seen that the mean annual maximum daily summer storm has not changed with time. The significant increase of the annual maximum daily rain in Borås can be attributed to changes in winter intensities. The daily winter rains in the other cities are small relative to the summer rains. The annual maximum occurs almost always in the summer. Since the summer maximum has not increased, there is no trend of increasing maximum annual daily rain, except in Borås.

Based on Table III, it seems that there has been an increase in the number of '20–30 mm/day' events at most of the stations. Such storms are considered large in the southern Swedish climate but still occur a couple of times every year. A storm of 20 mm/day occurs probably about two to four times per year at most of the stations. When comparing the last 20 years with the very early period from about 1880 up to 1930, it is seen that the number of annual events exceeding 20 mm/day is at least one event more for all the stations after 1990. For stations with few events, the increase is from about two to three events per year, and for Borås, from less than six events to nine events. Since there seems to be a relation between the number of moderate large daily storm events and annual precipitation, it can also be expected that the number of such events increases when the annual rainfall increases. This is investigated in more detail later in the paper. There is a significant increasing trend of events exceeding 20 mm/day for seven of the nine stations, although the significance is weak for two of the stations. The increase for Lund is shown in Figure 6. While

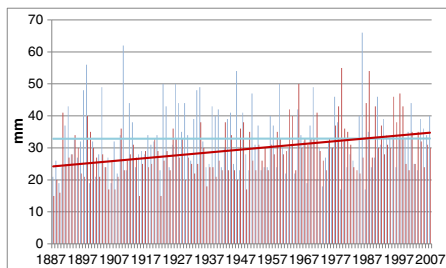

Figure 5. Annual maximum winter and summer daily precipitation with trend lines, Borås. Light colour denotes summer rain and dark winter rain

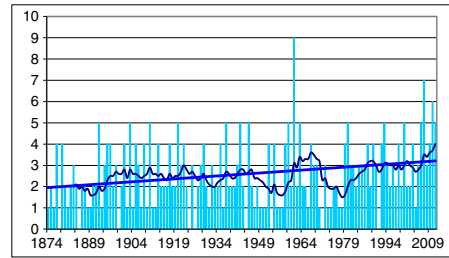

Figure 6. Number of annual events exceeding 20 mm/day in Lund showing trend and 10-year moving average

the mean number of events in a year was 2.3 in the period 1873–1930, it is 3.4 for the period 1990–2011. For all stations, the trends are stronger for the last 50 years than for the whole period. There is no trend of increasing number of 20 mm/day rains in Växjö or in Karlshamn for the long period. However, there is a significant increasing trend for Växjö after 1961. In Karlshamn, the number of '30 mm/day' events has increased significantly.

The increasing trend in the number of '20 mm/day' events is found also for the Skåne stations with records since 1961 (Table IV). This is consistent with what was found at the other stations. The mean annual maximum daily precipitation is about the same as for the nine stations with long records, in the range 31–34 mm, except at Brösarp almost at the east coast, where the annual maximum is 38 mm. The rain climate at Brösarp is rather special. The annual precipitation is almost exactly the same as the mean for Skåne (the southern region of Sweden), but there are some special weather conditions, when occasional south-easterly winds release rain when reaching the slopes of a <100-m-high ridge northwest of Brösarp. One of the largest non-official daily rain observations in Sweden (237 mm from 1959) is from a nearby area (Elleson and Persson, 1961).

The number of events of daily precipitation exceeding 30 mm/day has also increased. There is a considerable increase in the number of events that have occurred for all stations except Kalmar. The increase is one to two events in 10 years, but in Halmstad and Borås, the number of such events has doubled and increased by one event per year when comparing the years around 1900 (1880–1930) with the years around 2000 (1990–2011). All numbers are shown in Table III. Since the frequency of '30 mm/day' events is less than one per year, any form of trend analysis is doubtful. Therefore, the trend analysis was performed over decades instead of years. Significant increasing trends were then found for Borås, Lund and Karlshamn. Weak significance was found for Halmstad and Växjö. For all stations, although less clear in Kalmar, there is a considerable increase in the number of events that have occurred prior to 1930 and after 1960 and even more so

Table IV. Annual daily maximum rainfall and probability of large daily storm for the Skåne stations with records for 1961–2011

	Lund	Malmö	Krist	Karls	Hbg	Tbg	Skurup	Tom	Brsrp
Daily max	31.6	32.9	33.8	31.4	32.7	31.2* [†]	32.8	33.4	38.2
$P > 20$ mm	3.0* [†]	2.2*	2.5 [†]	2.5	3.0*	2.4*	3.5 [†]	3.2* [†]	3.7*
$P > 30$ mm	0.82	0.61	0.78	0.69	0.84*	0.51*	0.83*	0.86	1.11*
$P > 40$ mm	0.22	0.24	0.22	0.24	0.32	0.16*	0.28 [†]	0.29	0.32 [†]

*Significance level 2.5% (5% double-sided) or better.

[†] Better than 10% (double-sided).

Trend test is not attempted for the '30 mm/day' or the '40 mm/day' rains. The increase of the daily maximum is significant in Trelleborg with Mann-Kendall but only weakly significant with *t*-test (*[†]); the same is true for '20 mm/day' rain in Lund, while for Tomelilla, it is the other way (*[†]).

after 1990. The increase of the probability comparing the period prior to 1930 with the period after 1990 is typically from 0.7 to 0.9 per year. The increase of the frequency of '30 mm/day' events in Karlshamn, where the increase of 20 mm/day is not even weakly significant, may be noted.

Daily rains in the range of 20–30 mm represent rains with a return period of 0.5–2 years. The design storm of a certain return period is determined from statistics assuming certain probability distributions, or if the series is long and the return period short, directly from the ranking position in the observation series. 25 years ought to be long enough to directly determine the design storm of return periods of less than a few years. To see changes over time (from one given year to another) of the daily rains of different return periods, the rain intensities were computed year by year from the data of the 25 years previous to the given year (as would have been the only way if only 25 years of data were available). The intensity was determined from the rank position of the event. For the one-year storm, the intensity was determined as the mean of the three storms with ranking number 25, 26, and 27 and for the 0.5-year storm from ranking numbers 50, 51 and 52. In Figure 7, for Lund, it is seen that there is no trend in the intensity of these events with a low

return period. Although the number of '20 mm/day' and '30 mm/day' events has increased, the increase is so minor that design storms have not changed for the low return periods at any of the stations. The 0.5-, 1- and 2-year storms determined as moving values are stable over 100 years. The 5-year storm (taken as the mean of the 4th, 5th and 6th largest values over the 25-year period preceding the given year) varies more and is today actually low when considering only the last 25 years.

DAILY EXTREME PRECIPITATION

Following the convention used by SMHI, a daily storm exceeding 40 mm is considered to be an extreme storm. These storms and larger ones are discussed in this section. The probability of 40 mm daily precipitation at the different stations is shown in Tables III and IV. For many of the stations, the probability of a '40 mm daily rain' event is about 0.25 (return period of 4 years). Since, for 40 mm rains, there are more years with zero events than those with events, trend analysis of annual data was no longer attempted. When trend analysis was performed using the number of events per decade, no trends were found. For the very recent years, it can, however, be noted that in Trelleborg, there were six '40 mm/day' events in the 7 years from 2005 to 2011 (0.86 per year) of the total eight events in the entire period of 1961–2011 (0.20 per year). Trelleborg, together with Kalmar and Växjö, is the station with the lowest probability of such an event.

The very extreme events are larger than 40 mm/day. The further investigation in this section concerns the daily maximum precipitation ever recorded, the frequencies of precipitation exceeding 50 mm and 60 mm, and the expected 10-year and 100-year storms. The extreme values are determined using the Gumbel distribution, the GEV, and the POT approach, as explained in the Section on Statistics.

The 10-year storm can be computed directly from observations using the ranking order. The 10-year storm is in the range 45–55 mm (Tables V and VI), except at Brösarp, where it is 61 mm. The 100-year storm must be found from probability distributions. This storm varies much more between the stations than the 10-year storm does. For the

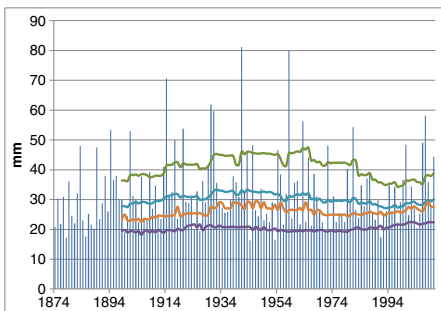

Figure 7. Storms of return periods of 0.5, 1, 2, and 5 years in Lund determined as moving average values from the previous 25 years

Table V. Extreme daily precipitation in millimetres (max observed, annual mean maximum), 100-year storm determined from POT analysis (P100-pot), the 10-year storm from observations (P10-obs) and expected number of events (Pb, probability) in a 100-year period; period from start of observations - 2011

	Lund	Malmö	Krist	Karls	Halm	Kalmar	Växjö	Gtbg	Borås
Max	81	97	95	75	81	72	145	100	67
Maxmean	32	32	33	31	35	29	33	35	35
P100-pot	71	89	87	62	99	64	98	78	60
P10-obs	49	54	48	46	49	45	50	49	49
Pb > 60 mm	4.4	5.8	3.2	1.5	6.0	1.5	6.7	4.5	1.5
Pb > 50 mm	9.4	10.8	8.5	6.0	9.0	6.0	8.9	10.0	8.5
Pb > 40 mm	21	20	24	19	35	16	21	26	40
Pb > 30 mm	72	60	71	55	105	52	53	100	150
Pb > 20 mm	260	220	240	230	370	200	240	430	640

Table VI. Extreme daily precipitation in millimetres (max observed, annual mean maximum), 100-year storm determined from POT analysis (P100-pot), the 10-year storm from observations (P10-obs) and expected number of events (Pb, probability) in a 100 year period; period 1961–2011

	Lund	Malmö	Krist	Karls	Hbg	Tbg	Skurup	Tom	Brsrp
Max	58	97	68	52	69	73	53	58	109
Maxmean	31.6	32.9	33.8	31.4	32.7	31.2	32.8	33.4	38.2
P100 pot	59	85	71	58	72	71	64	61	100
P10-obs	47	55	54	46	56	49	49	49	61
Pb > 60 mm	4.4	5.8	3.0	1.5	4.0	6.0	–	–	10
Pb > 50 mm	9	11	8	6	14	8	8	8	14
Pb > 40 mm	22	25	22	24	32	18	28	29	32
Pb > 30 mm	82	61	78	69	84	51	83	86	111
Pb > 20 mm	300	220	250	250	300	240	350	320	370

stations with at least 100 years' record, the lowest 100-year daily rain, about 60 mm, is found to be in Borås, Karlshamn and Kalmar. It is noted that Borås has the largest annual precipitation and Kalmar the lowest. Including the stations with only 50 years' record, the 100-year daily storm is low also at Skurup and Tomelilla, and when using only the last 50 years of data, it is also low in Lund (Table VI). The highest 100-year storm, about 100 mm in a day, is for Brösarp, Halmstad and Växjö. The annual precipitation is high in Halmstad but not at the other two stations. Although the annual precipitation in Brösarp is quite low, occasional rains from the east may cause large daily rains, as previously discussed. The statistics for Växjö is much influenced by two very large rains.

The highest daily rain observation at all the stations is from Växjö, 145 mm in 1945. The second highest storm from Växjö is also high, 97 mm in 1959. It is seen from Table V that the station with the lowest absolute maximum is Borås, where the annual precipitation is considerably higher than that at the other stations and where 20 mm, 30 mm and 40 mm daily rains are more common than at the other stations. As already discussed, the estimated 100-year storm is low for Borås, and it is seen from Table V that also the number of observed '60 mm daily' events is low. The

discrepancy of the Borås rains as compared to the rains in the other cities is explained by the large winter precipitation with many days of rather large frontal rains.

Different distributions were used to find the probability of the most extreme rains. The 100-year rains determined by the GEV and Gumbel approaches (not shown in the tables) are almost exactly as the POT-determined rains, except for the stations with maximum observations close to 100 mm/day, for which stations the GEV determined 100-year rains are about 5 mm lower and the Gumbel values about 10–15 mm lower than the rains computed with the POT approach.

When comparing the different stations (Tables V and VI) with respect to moderate storms and with respect to extreme storms, different characters appear. Comparing Malmö and Borås, it is seen that a 20-mm daily rain occurs three times more often in Borås than in Malmö and a 40-mm daily rain occurs two times more often, but a 50-mm rain is more common in Malmö than in Borås, and a 60-mm rain is much more common, although the probability of such a rain in Malmö is only one in 20 years. Except for Kalmar, Malmö has the lowest annual precipitation and also the lowest probability of '20 mm/day' events but still the highest probability of a '50 mm/day' event. The

number of '60 mm/day' and '50 mm/day' events differs much between the different stations and is not related to the number of high-frequency moderate events. A striking example is Trelleborg (Table VI). In Trelleborg, the probability of a 20-mm daily storm is almost the lowest at all stations. The probability of a rain 40 mm/day is the second lowest after that for daily rain in Kalmar. There have, however, been more 60-mm events than at almost all the other stations. The most extreme events seem to be random and not strongly correlated to mean statistics (neither to annual precipitation nor to the frequency of moderate rains), as will be discussed in more detail later in the paper.

A concern is whether the very extreme rain intensities have increased over the years. None of the very highest storms in the database used here has occurred in the last 30 years. Many of the largest observed rains are from the 1940s. There is rather a reduction of the 50-year and 100-year storms. Using a fixed number of previous years, the T-year storm can be determined as a moving value from year to year, as was already done for the more frequent storms. An example is shown in Figure 8 for Lund. The 50-year storm has been determined for a given year using the previous 25-year statistics. Gumbel distribution and the POT method were applied using the ten largest values over the 25 years for the POT approach. There is not a large difference between the Gumbel- and POT-determined values. It is seen that the magnitude of the 50-year storm varies much over the years. It is also seen that the highest 50-year storm is found around 1960 and the lowest at present. Using the whole data set, the 50-year storm is about 65 mm/day.

One or two very large events influence the outcome of the extreme value analysis. If the period is not very long, the output from the analysis may be confusing, when used for design or planning. Analysis of the Växjö rains can be used as an example. It is assumed that only 25 years of previous data are available or are used for analysing a given year (for example, data for 1945–1969 are used for

year 1969 and those for 1960–1984 are used for year 1984). The very large rain event of 145 mm in a day in 1945 and the 97-mm event in 1959 dominate the analysis until after 25 years, when they are no longer included in the 25-year data set. The 50-year storm event is, from 1985, reduced from more than 100 mm/day to no more than 50 mm/day. As was shown previously, the running T-event is more stable when the return period is short. It is difficult to determine a design rain for long return periods.

MULTI-DAY RAINFALL

There are some indications of increased clustering rainfalls (e.g. Vaes *et al.*, 2002). In the last years, flooding has occurred in southern Sweden following repeated rainfalls over several days (some descriptions of flooding events are given at SMHI.se/kunskapsbanken). While the annual daily maximum is somewhat more than 30 mm, the 2-day maximum is about 40 mm, and the 3-day maximum at most stations is about 45 mm or somewhat more. The trend of increasing multi-day events has been investigated for the nine cities, as was done in the many studies from Great Britain, which were previously reported on in this paper. 2-day, 3-day and 7-day precipitation totals were computed. For some of the stations, only monthly rainfall and the large single day rains are included in the database for the years 1931–1960 and not days with low precipitation. This means that multi-day rain amounts cannot be computed for all stations for these years. For these stations, trend analysis is performed only for the period after 1961. Instead, comparison is made between the multi-day rains before 1931 and the rains after 1961. The data for the nine major cities are shown in Table VII, and those for the Skåne stations are shown in Table VIII.

There is an increasing trend of the multi-day amounts of rainfall being at least weakly significant for the 3-day and 7-day rainfall for most of the stations over the last 50 years, i.e. for the period after 1961. It is also clear from Table VII that all mean annual maximum multi-day rains are larger in the last period from 1961 onwards than in the early observation period up to 1930. However, when testing the hypothesis that the rains are the same in the two about-50-year-long periods around the turn of the century in 1800–1900 and the turn of the century in 1900–2000 using t-test, the hypothesis could be rejected at the 5% level only for all the Borås multi-day rains (at better than 1%) and for the 7-day rain in Karlshamn. Again, the difference between Borås and the other cities is explained by the increased winter precipitation. There are non-significant differences for the 7-day rains at the other stations. Since the annual precipitation is very different between the two periods, it is expected that rains over such a long period as a week also are different. The *t*-values found from the

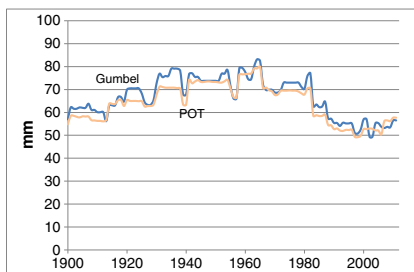

Figure 8. Fifty-year daily storm in Lund determined year by year using the 25 previous years: Gumbel distribution (dark colour) and POT approach (light colour) using the 10 highest values in the 25 years

Table VII. Multi-day rainfall totals (in millimetres)

	Lund	Malmö	Krist	Karls	Halm	Kalmar	Växjö	Gtbg	Borås
2-day	40* [†]	43					43	44	
Start–1930	39 [†]		38	37	44	35 [†]		43	47
1931–1960	41	36 ^{-†}					44	45	
1961–2011	42* [†]	42	42	39	45*	37 [†]	42*	45* [†]	51
1961–1990	40	40	41	38	41	34	37	42	50
1991–2011	44	44	44	40	51	41	49	47	53
3-day	46*	48					49	51 [†]	
Start–1930	44 [†]		43	42	55	39 [†]		50	55*
1931–1960	48	42 ^{-†}					49	51	
1961–2011	48* [†]	47 [†]	47 [†]	45	53*	42*	48*	53*	61
1961–1990	44	42	46	44	49	38	42	50	59
1991–2011	52	57	49	46	59	48	57	56	64
7-day	63* [†]	62 [†]					67	73	
Start–1930	60		57*	54	72	51 [†]		74	81*
1931–1960	63	55 ^{-†}					69	69	
1961–2011	67	62 [†]	62	61	78*	55*	67*	77*	96
1961–1990	64	58	60	60	74	51	58	73	93
1991–2011	72	77	65	63	84	62	77	83	101

*Significance 2.5% (5% double-sided).

[†] Significance 5% (10% double-sided).

Negative sign denotes decreasing trend. The linear *t*-test shows significance when the Kendall test only gives weak significance for 7-day rainfall in Lund, while it is the other way for the 2-day rain in Lund and the 2-day rain in Göteborg after 1961. Weak significance is found with *t*-test for 2-day rains in Kalmar prior to 1930 and for 3-day rainfall in Kristianstad after 1961, but no significant trend was found with the Kendall test. Trends were not investigated for the short 20- to 30-year period of 1961–1990 or 1991–2011. The sequence of the footnote citations (*[†]) is explained in Table 4.

Table VIII. Multi-day rainfall totals (in millimetres; period 1961–2011)

	Lund	Malmö	Krist	Karls	Hbg	Tbg	Skurup	Tom	Brsrp
2-day	42 [†]	42	42	39	42*	40*	42*	44	48
3-day	48 [†] *	47 [†]	47 [†]	45	48*	45*	48*	49	54*
7-day	67	62 [†]	62	61	67*	60*	69 [†]	69	72

*Significance 2.5% (5% double-sided).

[†] Significance 5% (10% double-sided).

hypothesis testing are shown in Table IX. The table also includes 1-day rains. The *t*-values are higher for the rains of long duration. The *t*-value corresponding to 10% weak significance of different rains in the two periods is about 1.7.

The period 1961–1990 is used as reference in many studies. The mean annual maximum is low for this period for all the multi-day rains. The 1991–2011 values are much higher. As shown in the tables, there have been increasing trends over the last 50 years for most of the multi-day rains. However, when analysing the differences between the reference period with low rain intensities and the last 20 years with higher rain intensities, there are significant differences only for all the rains in Halmstad and Växjö, and for the 3-day and 7-day rains in Malmö and Kalmar.

The data set is complete for Lund, Malmö, Växjö and Göteborg also for the period 1931–1960, including all days and days with little or no precipitation. The 3-day precipitation for the full period 1873–2011 is shown for Lund in Figure 9. The increasing trend of annual 3-day

maximum rainfall is significant for the whole period, but the trend is much larger over the last 50 years than for the whole period. However, very many of the largest 3-day events occurred in the 1930s and the 1940s, so one should be careful when extending the 1961–2011 trend line.

In the same way as for the 1-day rain event, the *T*-year multi-day rainfall was investigated. The 50-year 3-day rainfall is determined as a running mean using the 25 previous years. The 50-year rain in Lund can be computed continuously from 1900. For this series, there is no trend, but there are large variations over the more-than-100-year-long period. The 3-day rain with a 50-year return period was as shown in Figure 10, high from 1940 to 1970, low in the 1980s but are now, although lower, approaching the values of the period 1940–1970. The 50-year rain determined in this way has increased from less than 80 mm during the 1990s to 95 mm. Also, the 2-year and 5-year 3-day rains are shown in Figure 10. The 2-year rain is stable over the whole period, while the 5-year storm varies within a range of 20%.

LONG-TERM CHANGE OF DAILY AND MULTI-DAILY PRECIPITATION IN SWEDEN

Table IX. Hypothesis test comparing the two periods: from the beginning of the observations (about 1880) to 1930, and the period 1961–2011

	Lund	Krist	Karlsh	Halm	Kalmar	Gtbg	Borås
1-day	0	1.3	0	0	0	0	2.2*
2-day	1.3	1.8 [†]	0	0	0	0	2.9*
3-day	1.4	1.8 [†]	1.2	0	0	0	3.9*
7-day	1.9 [†]	1.8 [†]	2.4*	1.4	1.2	0	4.9*

*Significance 2.5% (5% double-sided).

[†] Significance 5% (10% double-sided).

From the *t*-test, the found *t*-values are given. Values less than 1.15 (30% double-sided) are shown as 0.

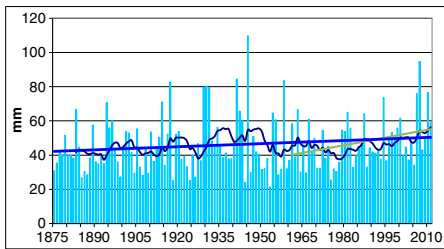

Figure 9. Annual maximum 3-day precipitation in Lund with trend line and the trend since 1960

Considering only the last 50 years, trends of increasing annual maximum 3-day precipitation were found for almost all of the stations. Also, the more extreme events of multi-day duration are found to have increased when only the last 50 years are considered. An example is shown for 3-day rains in Trelleborg in Figure 11. The increase of the 50-year 3-day rain is significant. The 50-year storm is computed using a Gumbel probability distribution with parameters determined continuously from rain data 25 years back. Because of many very large extended rains, the computed 50-year 3-day storm for Trelleborg has increased from about 80 mm to well over 90 mm.

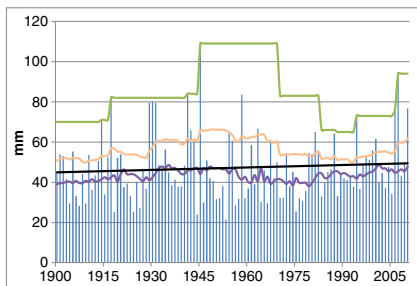

Figure 10. Fifty-year, 5-year and 2-year 3-day events in Lund determined continuously using 25 years of data

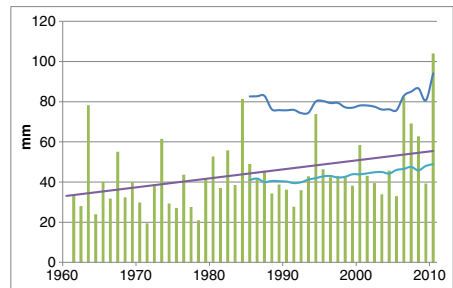

Figure 11. Annual maximum 3-day rain in Trelleborg, including trend line, 25-year running mean and 50-year 3-day event determined using Gumbel distribution continuously from the previous 25 years (upper curve)

RELATION EXTREME EVENTS TO ANNUAL PRECIPITATION

In the previous sections, it has been found that the annual precipitation has increased from the late 1800s to the early 2000s; also, the number of moderate large events of daily precipitation and multi-day precipitation has increased. The frequency of short return period events seems to be higher at places where the annual precipitation is high as compared to places with less annual precipitation, while there does not seem to be any strong relation between the extreme precipitation events and large annual precipitation. For the 14 stations analysed so far, there is no correlation at all between the 100-year daily rain and the annual precipitation. More stations are required to generalize such a statement. Therefore, the relations between annual precipitation and large rainfall events were investigated using the 30-year-long records from the more-than-200-station network in Skåne. Of these stations, the 90 with complete records of at least 28 years were included in the analysis. As already discussed and shown in Figure 2, the annual maximum occurred at 28 different stations during the 30-year measuring period, indicating that a relation between extreme rains and annual precipitation or geographical parameters cannot easily be found.

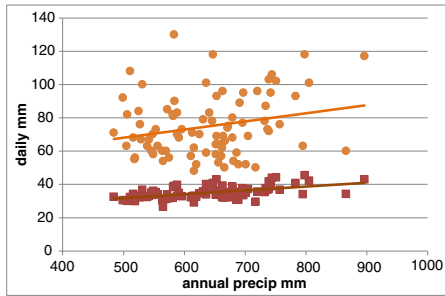

Figure 12. Relation between mean annual maximum and annual precipitation, and between 100-year daily rain computed from assumed GEV distribution and annual precipitation from observation at 90 stations in Skåne in the period 1961–1990

The daily rains of 100-year return period as computed from a GEV distribution and the annual mean maximum rains were plotted versus the annual precipitation and are shown in Figure 12. The relation mean annual maximum daily rain (P_{day}) and annual precipitation (P_{annual}) is linear with not very much scatter. Despite very high significance of the relation between P_{day} and P_{annual} , the explained variance is no better than 20%. The relation is (in millimetre per day and millimetre per year)

$$P_{\text{day}} = 23.3 + 0.0186 P_{\text{annual}}$$

For the relation between 100-year daily rain and annual precipitation, the explained variance is almost zero, 0.04. Still, the relation is close to being significant having a t -value of 1.7, which means a significance level of 10%. It can be noted that the largest 100-year value, 130 mm, is for a station with rather little annual precipitation, 570 mm, and that for the station with the second largest annual precipitation, the 100-year rain is lower than for most of the other stations. Because of the large scatter, the relation between the 100-year rain and the annual precipitation is not of much value in a regional or local analysis of extreme rains. However, the relation annual maximum rain and annual precipitation, as was shown for Denmark by Madsen *et al.* (1998) and for Sweden by Dahlström (1979), can be used for estimating local intensity–duration–frequency curves.

CONCLUSIONS

From data series dating back to the 1870s, it is clear that the annual precipitation has increased in southern Sweden. The increase is about 20%. The increase is due to increased winter precipitation. The summer precipitation has not changed. For most of the stations, the trend is the strongest after 1960. The number of large events with

a return period of less than a year has also increased. This is expected since the annual precipitation has increased. Indeed, from a very large precipitation gauge network, an almost linear relation between mean annual maximum daily storms and annual precipitation was found. The increase in the number of high frequency rains is attributed to an increased number of large winter storms and is strongest for the stations with the largest annual precipitation. The annual daily maximum rainfall has increased significantly only in Borås, where the annual maximum occurs almost as often in winter as in summer. At the other cities, the summer maximum is considerably higher than the winter maximum.

For events with a return period of many years, it is not possible to find any trends in changing probabilities. No clear relation between the largest storms and annual precipitation was found. The annual maximum daily rainfall was found to occur at different stations from year to year, although the stations have large differences in annual precipitation. When design storms were determined using 25 years of previous data and updating year by year, it was found that design storms of long return periods and thus the probabilities of extreme storms were the highest in 1930–1980 and have decreased thereafter. The probabilities of very large daily precipitation with a return period of 10–50 years are 20% lower today than 50 years ago and are the same as 100 years ago. No strong conclusions can be drawn from this since some large rainfalls influence the extreme value analysis much, but it can be stated that the most extreme daily storms have not increased in intensity.

The annual maximum of multi-day rainfalls has increased over the last 50 years. When comparing the multi-day mean values in the period 1880–1930 with the 1990–2011 values, the latter are about 10–15% higher, but the differences are significant only for the station with large winter precipitation. When analysing for the very extremes, it was found that there has not been a significant increase of large multi-day rains since the late 1800s. However, there is a non-significant increase in the 7-day rains at all the stations.

This investigation can be summarized as follows: The winter precipitation in southern Sweden has increased much over the last 100+ years, which has resulted in more frequent daily and multi-daily storms of shorter-than-1-year return periods, but the extreme storms of long return periods have not changed.

ACKNOWLEDGEMENTS

The study was financed by a grant from FORMAS and Swedish Water Development. The second author is in Sweden on a European Erasmus scholarship.

REFERENCES

- Ångström A. 1941. Nederbörds klimatets ändring i nuvarande tid. (The variation of the precipitation climate in present time – English summary). *Swedish Meteorological and Hydrological Institute*, Communication series of papers No 37, 17 pp.
- Bengtsson L. 2011. Rain in southern Sweden. *Hydrology Research* **42**: 82–94.
- Bengtsson L, Milotti S. 2010. Intensive storms in Malmö. *Hydrological Processes* **24**: 3462–3475.
- Dahlström B. 1979. Regional fördelning av nederbördsintensitet – en klimatologisk analys (Regional distribution of storm intensities – a climatological analysis). *Bygghälsningsverket* **R18**: 1979, 83.
- Dahlström B. 2006. Regnintensitet i Sverige – en klimatologisk analys (Storm intensities in Sweden – a climatological analysis). *VA-Forsk rapport* Nr 2006-26, 69 s.
- Elleson J, Persson R. 1961. Skyfallsartade regn över Skåne (Extreme storms in Skåne). *Svensk Geografisk Årsbok* **37**: 51–55.
- Førland EJ, Alexandersson H, Drebs A, Hanssen-Bauer I, Vedin H, Tveito OE. 1998. Trends in Maximum 1-Day Precipitation in the Nordic Region, DNMI Report 14-98 klima, Norwegian Meteorological Institute, Oslo, 1–55.
- Fowler HJ, Kilsby CG. 2003. A regional frequency analysis of United Kingdom extreme rainfall from 1961 to 2000. *International Journal of Climatology* **23**: 1313–1334.
- Gellens D. 2000. trend and correlation analysis of k-day extreme precipitation over Belgium. *Theoretical and Applied Climatology* **66**: 117–129.
- Hägström M. 2001. Utredning om klimatförändring, flödesbestämning och havsnivåförändring (Investigation about climate change, river discharge predictions and sea level changes). SMHI-report for Vägverket Appendix 4, 16 pp.
- Haugen JE, Iversen T. 2008. response in extremes of daily precipitation and wind from a downscaled multi-model ensemble of anthropogenic global climate change scenarios.
- Hellström C. 2005. Atmospheric conditions during extended and non-extended rain events in Sweden. *International Journal of Climatology* **25**: 631–648.
- Hennessey KJ, Gregory JM, Mitchell JFB. 1997. Changes in daily precipitation under enhanced greenhouse conditions. *Climate Dynamics* **13**: 667–680.
- Hundecha Y, Bårdassy A. 2005. Trends in daily precipitation and temperature extremes across western Germany in the second half of the 20th century. *International Journal of Climatology* **25**: 1189–1202.
- Kao Sh-Ch, Ganguly AR. 2011. Intensity, duration, and frequency of precipitation extremes under 21st-century warming scenarios. *Journal of Geophysical Research*, **16**(D16119): 1–14.
- Kharin VV, Zwiers FW. 2000. Changes in the extremes in an ensemble of transient climate simulations with a coupled atmosphere–ocean GCM. *Journal of Climate* **13**: 3760–3788.
- Kunkel KE, Easterling DR, Redmond K, Hibbard K. 2003. Temporal variations of extreme precipitation in the United States: 1895–2000. *Geophysical Research Letters* **30**, No.17, 1900, CLM 5, 1–4.
- Kunkel KE, Karl THR, Easterling DR. 2007. A Monte Carlo assessment of uncertainties in heavy precipitation frequency variations. *Journal of Hydrometeorology* **8**: 1152–1160.
- Kveton V, Zak M. 2008. Extreme precipitation events in the Czech Republic in the context of climate change. *Advances Geosciences* **14**: 251–255.
- Lupikasza E. 2009. Spatial and temporal variability of extreme precipitation in Poland in the period 1951–2006. *International Journal of Climatology* **30**: 991–1007.
- Madsen H, Mikkelsen PS, Rosbjerg D, Harremoes P. 1998. Estimation of regional intensity-duration-frequency curves for extreme precipitation. *Water Science and Technology* **37**: 29–36.
- Madsen H, Arnbjerg-Nielsen K, Mikkelsen PS. 2009. Update of regional intensity-duration-frequency curves in Denmark. Tendency towards increased storm intensities. *Atmospheric Research* **92**: 343–349.
- Maraun D, Osborn TJ, Gillett NP. 2008. Short Communication: United Kingdom daily precipitation intensity: improved early data, error estimates and an update from 2000 to 2006. *International Journal of Climatology* **28**: 833–842.
- McGuffie K, Henderson-Sellers A, Holbrook N, Kothavala Z, Balachova O, Hoekstra J. 1999. Assessing simulations of daily temperature and precipitation variability with global climate models for present and enhanced greenhouse climates. *International Journal of Climatology* **19**: 1–26.
- Mishra AK, Singh VP. 2010. Changes in extreme precipitation in Texas. *Journal of Geophysical Research* **115**, D14106, doi:10.1029/2010JD13398.
- Moberg A, Jones Ph. 2005. Trends in indices for extremes in daily temperature and precipitation in central and western Europe, 1901–99. *International Journal of Climatology* **25**: 1149–1171.
- Moberg A, Jones PD, Lister D, Walther A, Brunet M, Jacobeit J, Alexander LV, Della-Marta PM, Luterbacher J, Yiou P, Chen D, Klein Tank AMG, Saladié O, Sigró J, Aguilar E, Alexandersson H, Almarza C, Auer I, Barriendos M, Begert M, Bergström H, Böhm R, Butler CJ, Caesar J, Drebs A, Founda D, Gerstengarbe F, Micela G, Maugeri M, Österle H, Pandzic K, Petrakis M, Smec L, Tolasz R, Tuomenvirta H, Werner PC, Linderholm H, Philipp A, Wanner H, Xoplaki E. 2006. Indices for daily temperature and precipitation extremes in Europe analyzed for the period 1901–2000. *Journal of Geophysical Research* **111**, paper D22106, 25.
- Osborn TJ, Hulme M. 2002. Evidence for trends in heavy rainfall events over the UK. *Philosophical Transactions of the Royal Society A: Mathematical, Physical & Engineering Sciences* **360**: 1313–1325.
- Räisänen J, Joëlsson R. 2001. Changes in average and extreme precipitation in two regional climate model experiments. *Tellus* **53**: 547–566.
- Rosbjerg D. 1988. A defense of the median plotting position. *Dept. Hydrodynamics and Water Resources*, Danish Technical University, Rep. 66, 29pp.
- Rosbjerg D, Madsen H, Rasmussen PF. 1992. Prediction in partial duration series with generalized Pareto-distribution exceedances. *Water Resources Research* **28**: 3001–3010.
- Schmidli J, Frei Ch. 2005. Trends of heavy precipitation and wet and dry spells in Switzerland during the 20th century. *International Journal of Climatology* **25**: 753–771.
- Semenov VA, Bengtsson L. 2002. Secular trends in daily precipitation characteristics: greenhouse gas simulation with a coupled AOGCM. *Climate Dynamics* **19**: 123–140.
- Semmler T, Jacob D. 2004. Modeling extreme precipitation events - a climate change simulation for Europe. *Global and Planetary Change* **44**: 119–127.
- Skaugen Th, Astrup M, Roald LA, Førland E. 2003. Scenarios of extreme daily precipitation for Norway under climate change. *Nordic Hydrology* **35**: 1–13.
- Trenberth KE. 2011. Changes of precipitation with climate change. *Climate Research* **47**: 123–138.
- Trenberth KE, Dai A, Rasmussen RM, Parsons DB. 2003. The changing character of precipitation. *Bulletin of the American Meteorological Society* **84**: 1205–1217.
- Trömel S, Schönwiese C-D. 2007. Probability change of extreme precipitation observed from 1901 to 2000 in Germany. *Theoretical and Applied Climatology* **87**: 29–39.
- Vaes G, Willems P, Berlamont J. 2002. 100 years of Belgian rainfall: are there trends? *Water Science and Technology* **45**(2): 55–61.
- Zhang X, Hogg WD, Mekis É. 2001. Spatial and temporal characteristics of heavy precipitation events over Canada. *Journal of Climate* **14**: 1923–1936.

Appended paper

IV

Rana, A., Foster, K., Bosshard, T., Olsson, J. and Bengtsson, L. (2013) Impact of Climate change on rainfall over Mumbai using Distribution Based Scaling (DBS) of Global Climate Model (GCM) Projections. (Manuscript)

Impact of Climate Change on Rainfall over Mumbai Using Distribution-Based Scaling (DBS) of Global Climate Model (GCM) Projections

Arun Rana^{*1}, Kean Foster^{1,2}, Thomas Bosshard², Jonas Olsson² and Lars Bengtsson¹

¹Department of Water Resources Engineering, LTH, Lund University

Box No.118, Lund, Sweden 22100

²Swedish Meteorological and Hydrological Institute, Norrköping, Sweden 60176

Abstract

Projections provided by general circulation models (GCMs) suggest that the probability in the occurrence of intense rainfall will change in the future. However, GCM data generally need to be downscaled and bias corrected for impact studies at finer spatial resolutions. Although the domains covered by Regional Climate Models (RCMs) are increasing worldwide, e.g. through the CORDEX experiment (REF), statistical downscaling of GCM results is (1) still required in many regions and (2) is a computationally cheaper approach that potentially still offers an accurate alternative to RCMs. Here, we applied a distribution-based scaling (DBS) procedure for bias-correcting and downscaling daily rainfall data from 9 global climate projections. The DBS procedure uses the period 1975-2004 as a reference. The evaluation in the reference period showed that observed and scaled model data were strongly correlated and that the scaled data are able to represent various key statistics including mean, variance and extreme values. The DBS model performance is satisfactory in preservation of rainfall properties for the study area along with seasonal variations in line with observed statistics. It was also noticed that the GCMs were unable to reproduce the southwest monsoon season in the study, thus creating a bias, which is preserved in the DBS corrected data, although to lesser degree. The DBS model was then used to scale daily data of the nine GCMs for the reference period and the climate projection period 2010-2099. Using the transient DBS processed projection data; an impact analysis (climate and extreme values statistics) was performed for the four projection periods of near future (2010-2040), intermediate future (2041-2070), distant future (2071-2099), and for the entire future period of 2010-2099 for long-term analysis. Trend analyses using student t and Mann- Kendall tests were also performed on long-term projections. The analysis of future long-term climate projections reveals a significant positive trend for 4 out of 9 models used in the study for daily extreme rainfall for the period 2010-99. There is an increase in the total accumulated annual rainfall, ranging from 300~500mm, in all the projections for all the models. The models point towards an increased rainfall of varying degrees in all. There is an increase in rainfall in September and a decrease in June, showing a relative shift or delayed onset of the monsoon season, which can be attributed to bias in raw GCM data itself.

Keywords: *Distribution-Based Scaling (DBS), Global Climate Models (GCMs), Impact analysis, Climate change, Mumbai*

1. Introduction

Extreme weather events have severe consequences for human society. The impacts of the changing climate will likely be perceived most strongly through changes in intensity and frequency of climate extremes. Studies have found that human activities have contributed to an increase in concentrations of atmospheric greenhouse gases contributing to intensification of heavy rainfall events (Min et al., 2011). In the context of hydrology, the changing climate will likely accelerate the hydrological cycle on a global scale, and subsequently intensify the uneven spatial and temporal distribution of hydrological resources (Huntington, 2006; Trenberth, 1999). The intensity of extreme rainfall events are projected to increase under global warming in many parts of the world, even in the regions where mean rainfall decreases e.g., (Semenov and Bengtsson, 2002; Wilby and Wigley, 2002). Thus climate adaptation strategies for e. g. emergency planning, design of engineering structures, reservoir management, pollution control, or risk calculations rely on knowledge of the frequency of these extreme events (Kumke, 2001). Assessment of these extreme rainfall events is important in hydrological risk analysis and design of urban infrastructures. The increasing trend of rainfall extremes has quantifiable impacts on intensity duration frequency relations (Kao and Ganguly, 2011). Climate change is expected to alter the intensity and frequency of extreme rainfall events (Frei et al., 1998; Frei et al., 2006; Kharin et al., 2007; McKibben, 2007) and an increase in the intensity and/or frequency of extreme rainfall events may result in the flooding of urban areas (Ashley et al., 2005; Mailhot et al., 2007).

In India, rainfall variability is a central driver of the national economy. A change in extreme events would have a large impact on the growing economy of India as most of the population live in urban areas. Several studies have addressed the issue of trends in rainfall in India since last century. Long-term southwest monsoon/annual rainfall trends over India as a whole were previously studied by (Parthasarathy et al., 1993; Rana et al., 2012); among others. Long term trends for the last 50 years indicate a significant decrease in the frequency of moderate-to-heavy rainfall events over most parts of India e.g., (Dash et al., 2009; Naidu et al., 1999). This is corroborated by a significant rise in the frequency and duration of monsoon breaks over India during recent decades (Ramesh Kumar et al., 2009; Turner and Hannachi, 2010), while the frequency of extreme rainfall events (100 mm/day) have increased in certain parts of the country (Goswami et al., 2006). Many studies have described the possible impacts of climate change on urban drainage infrastructures and analysed the specific impacts on various urban areas, e.g (Mailhot et al., 2007); (Willems et al., 2012). These possible impacts could have serious implications for Mumbai, the economic hub of India.

General circulation models (GCMs) are currently the best way to model the complex processes that occur at the global scale (i.e. for studying possible future changes in climate mean, variability, and extremes) (Huntingford et al., 2005). Climate change studies are essential in order to provide information for policy making and adaptation strategies (Stainforth et al., 2007). Climate models and hydrological models are important tools used in these studies (Boé et al., 2007; Chen et al., 2007; Guo et al., 2002; Xu, 2000; Xu et al., 2005). In most climate change studies, GCMs have been used to project future climatic variables. However, due to a limitation of GCMs to incorporate local topography (spatial and temporal), coarse horizontal resolution and inaccuracy of describing rainfall extremes due to a poor description of the non-stationary phenomenon during a convective storm, the direct use of their outputs in impact studies on

catchment scale is limited. There is often a clear bias in the statistics of variables produced by GCMs such as rainfall and temperature (Kay et al., 2006; Kotlarski, 2005). To bridge the gaps between the climate model and local scales, and to account for the inaccuracies in describing rainfall extremes, downscaling and bias-correction methods are commonly used in practice. Dynamic downscaling and statistical downscaling are the most commonly used methods (Bergstrom, 2001; Fowler et al., 2007; Pinto et al., 2010; Schoof et al., 2009; Wilby et al., 1999). Dynamic downscaling by Regional Climate Models (RCMs) ensures consistency between climatological variables, however they are computationally expensive. Statistical downscaling models, on the other hand, are based on statistical relationships and hence require less computational time. Extensive research has been carried out with both approaches e.g., (Chen et al., 2012; Maraun et al., 2010; Teutschbein et al., 2011; Willems and Vrac, 2011).

Hydrologically important variables need to be adjusted to obtain realistic time series for use in local impact studies (Graham et al., 2007). A conventional way to adjust future time series is referred to as bias correction (Lenderink, 2007) where correction factors are derived by comparing the GCM output with observed weather variables in the reference period, and then applied to GCM output for future climate. The bias correction approach is easy to implement, and it further reproduces the variability described by different climatic conditions generated by GCM projections. One disadvantage to this approach is the assumption of stationarity, the assumption that the correction factors do not change with time. Here, we adopt the distribution based scaling method (Yang et al., 2010) for bias-correction and downscaling of the GCM data.

Concerning India, future climate studies based on climate model simulations suggest that greenhouse driven global warming is likely to intensify the monsoon rainfall over a broad region encompassing South Asia e.g., (Lal et al., 2000; May, 2002; May, 2004; May, 2011; Meehl and Arblaster, 2003; Rupakumar et al., 2006). However, precise assessments of future changes in the regional monsoon rainfall have remained ambiguous due to wide variations among the model projections e.g., (Annamalai et al., 2007; Fan et al., 2010; Kripalani et al., 2007; Kumar et al., 2011; Sabade et al., 2011). The simulated rainfall response to global warming by climate models is actually accompanied by a weakening of the southwest monsoon e.g., (Kripalani et al., 2003; Krishnan et al., 2013; Sabade et al., 2011; Stowasser et al., 2009; Ueda et al., 2006). However, Rupakumar et al. (2006) have studied the effect of climate change in India by evaluating the present day simulation (1961-1990) of the PRECIS climate model and have reported an increase in extreme rainfall along the west coast and western parts of central India. This study, to the knowledge of the authors, is the only study being conducted to investigate the effects of climate change on the potential impacts of extreme rainfall in study area using data from several climate models.

As indicated by (Rana et al., 2012), the rainfall intensity and frequency for Mumbai is related to certain global climate indices such as the Indian Ocean Dipole, the El Niño-Southern Oscillation and the East Atlantic Pattern. These established connections between local rainfall and large-scale climate features suggest the possibility to statistically downscale GCM data directly to the local scale. It would therefore be interesting to examine the effects of climate change in the Mumbai area. This goal can be achieved by studying the future projections for the region, as given by the climate. The objective of this paper is to apply a distribution based scaling (DBS) technique, which has been tested and applied to RCM data, to scale GCM data. This includes the

implementation of the DBS model on GCM projections for the area, analysing the scaling methodology and its usefulness in scaling GCM climate data, and finally analysing the future impacts on the city of Mumbai due to climate change as projected by the different GCM projections. A synthesis of this research is presented in the statistical analysis of nine different GCMs for three future climate projection periods. Biases in rainfall can create large errors in the evaluation of impacts on a city. Thus good model representation of the monsoon season is important to estimate risks and efficiently plan the drainage system. Thus, adjustment for biases in the GCM outputs is necessary before they can be used in impact studies.

The study is divided into 4 sections. Section 1 deals with introduction, section 2 describes the data used and introduces the methodology where we present Distribution based scaling (DBS) method for Global Climate Model Projections (GCMs) and its usage in impact analysis of future projections. Section 3 deals with results and discussion where we have presented DBS methodology for scaling GCM data and its applicability in the area followed by impact analyses in future projections from 9 climate models, finally in section 4 conclusions are outlined.

2. Study area, data and methods

2.1 Study area

The study is carried out for the city of Mumbai, formerly Bombay ($18^{\circ}58'30''N$ $72^{\circ}49'33''E$) and the capital of Maharashtra state, it is located in the south western part of India. Mumbai is located on the windward side of the Western Ghats of India and receives high rainfall, both in magnitude and intensity, owing to the orographic effect from strong westerly and south-westerly monsoon flows over the Arabian Sea. The average annual rainfall of Mumbai is 2142 mm with monsoon rainfall accounting for 96% of the total annual rainfall (Rana et al., 2012). During the monsoon, it usually rains uniformly over the city and severe flooding occurs in many parts. The duration of a rainfall event usually ranges from 30 min to 120 min, however in some cases they can be as long as 3-4 hours (Rana et al., 2013). Daily rainfall amounts of up to 250 mm are common during monsoon season (Rana et al., 2012).

2.2 Data

Observed daily rainfall data for the Colaba station ($18^{\circ}54' N$ $72^{\circ} 49'E$) in Mumbai, covering the period 1975-2005, was obtained from the India Meteorological Department (IMD). This data is used as a reference for bias-correction using the DBS. Daily rainfall data from nine climate models (see Tab. 1) was extracted from the CMIP5 database, provided by MOHC (Met Office Hadley Centre) (<http://badc.nerc.ac.uk/home/>). Readers are suggested to refer to “WCRP Coupled Model Intercomparison Project” report and its references for details about the data (CLIVAR Exchanges, 2011) (WCRP, 2011). The projections used in this paper are from the same scenario runs. We use the period 1975-2004 as the reference period, and the three periods 2010-2040, 2041-2070 and 2071-2099 as projection periods for the near, intermediate and far future, respectively.

2.3 Methods

2.3.1 Bias-correction

We have used the Distribution Based Scaling (DBS) Method (Yang et al., 2010) to downscale and bias-correct the climate model data for both historical and future projections. As for most

post-processing methods, it was assumed that simulations generated by GCM for the control period cover the full range of climate processes and events that occur in the present climate, and is thus representative of present climate conditions up to a systematic and stationary bias. The DBS approach used two steps: (1) spurious drizzle generated by the GCM model was removed to obtain the correct percentage of wet days and (2) the remaining rainfall was transformed to match the observed cumulative probability distribution in the reference data. In step 1, simulated and observed daily rainfall was sorted in descending order. The cut-off value was then defined as the threshold that reduced the percentage of wet days in the simulation to that of the observations. Days with rainfall amounts larger than the threshold value were considered as wet days and all other days as dry days (Yang et al., 2010).

In step 2, gamma distributions are fitted to the daily rainfall data on wet days, both for the observational and the climate model data. DBS applies a gamma distribution because of its ability to represent the typically asymmetrical and positively skewed distribution of daily rainfall intensities, (Haylock et al., 2006). The gamma distribution is a two-parameter distribution whose density distribution is expressed as:

$$f(x) = \frac{(x/\beta)^{\alpha-1} \exp(-x/\beta)}{\beta \Gamma(\alpha)} \quad x, \alpha, \beta > 0 \quad \dots (1)$$

where α is the shape parameter, β is the scale parameter and $\Gamma(x)$ is the gamma function. The distribution parameters were estimated using maximum likelihood estimation (MLE). Daily rainfall distributions are typically heavily skewed towards low-intensity values. As a result, the distribution parameters will be dominated by the most frequently occurring values, but may not be able to accurately describe the properties of extreme values. To capture the main properties of normal rainfall as well as extremes, the rainfall distribution was divided into two partitions separated by the 95th percentile. Two sets of parameters – α, β and α_{95}, β_{95} – were estimated from observations and the GCM output for the reference period 1975–2004. These parameter sets were in turn used to bias-correct daily rainfall data from GCM outputs for the entire projection period up to 2099 using the following equations:

$$\begin{cases} P_{DBS} = F^{-1}(\alpha_{Obs}, \beta_{Obs}, F^{-1}(P, \alpha_{CTL}, \beta_{CTL})) & \text{if } P < 95^{\text{th}} \text{ percentile value} \\ P_{DBS} = F^{-1}(\alpha_{Obs,95}, \beta_{Obs,95}, F^{-1}(P, \alpha_{CTL,95}, \beta_{CTL,95})) & \text{if } P \geq 95^{\text{th}} \text{ percentile value} \end{cases} \quad \dots (2)$$

where the suffix Obs denotes parameters estimated from observations in the reference period and the suffix CTL denotes parameters estimated from the GCM output in the reference period. F represents the cumulative gamma probability distribution associated with the probability density function f (see equation 1). To take seasonal dependencies into account, the parameter sets were estimated for each season separately: pre-monsoon (March–May), Southwest monsoon (June–September), post-monsoon (October–November) and winter (December– February).

2.3.2 DBS Evaluation and analysis of the climate change signal

Evaluation of DBS scaling procedure is done by comparing different climate statistics including accumulated rainfall, mean, standard deviation, coefficient of variance (CV), and percentage of annual rainfall for observed, raw GCM and bias-corrected GCM data. From the basic daily rainfall all the statistics were computed monthly for the Southwest monsoon season and season-wise for the other seasons. Comparison between the simulations and observations are done various different statistics for the whole evaluation period, i.e. not for individual days or years. A mean annual cycle curve, using a 31-day moving average, for the reference period was also

plotted to evaluate the seasonal cycle more continuously. Rainfall extremes were studied by one-day, two-day, three-day and seven-day annual maxima, for all the years of a particular period individually, and averaged over the whole analysis period using Lognormal and Gumbel Distributions. The same statistics are also presented in form of box plots for further analysis. Annual maxima are then fitted using log normal and Gumbel distribution functions (Generalized Extreme Value distribution) and the values for the 50 and 100 year return periods are determined. Percentages in the frequency of rainfall events in Observed, Raw GCM and GCM DBS corrected data were also calculated.

The analysis of the climate change signal is done for all the nine GCM projections and for the periods 2010-2040, 2041-2070, 2071-2099 and 2010-2099 for studying near, intermediate, distant and long-term future climates using various statistical means and the relative change with respect to reference projections. Extreme values statistics were calculated for all projection periods using Log normal and Gumbel distribution functions for return periods of 50 and 100 years as suggested by (Majumdar and Sawhney, 1965). The average of all the projections was also studied to assess the most likely changes, based on the nine-member ensemble. The extreme value statistics in all projections and future periods were subjected to Mann–Kendall and student t tests (linear regression) for long-term trend analysis for the whole transient period (2010-2099). The linear regression method is widely used to determine long-term trends seasonally, annually, and for daily maximum rainfall e.g. (Gadgil and Dhorde, 2005), among many others. The non-parametric Mann–Kendall test is used here as a significance test. The procedure of carrying out this statistical test is outlined by (Mitchell et al., 1966).

3. Results and Discussion

We have divided the results section into three parts where we present the evaluation of DBS scaling procedure (subsection 3.1), this is followed by the analysis of the climate projections for the near future (2010-2040), intermediate future (2041-2070) and distant future (2071-2099) (subsection 3.2). Subsection 3.3 deals with trend analysis for the entire future period (2010-2099) for detecting any long-term trends in the climate projections.

3.1 Evaluation of the DBS methodology for rainfall during the reference period (1975-2004):

The evaluation statistics, including accumulated rainfall, mean, standard deviation, coefficient of variation and percentage contribution to annual rainfall for seasonal, monsoon and annual data period, are presented in table 2. For brevity, we show the results for only NCAR_CCSM4 and the NorESM1_M (as these models give the closest representation of observed data or climate signal in raw GCM data) for all statistical evaluation with the observed data; for readers interested in statistics for the other models are referred to appendix 1. It can be observed from table 2 that there is a marked improvement in the reproduction of the climate statistics for both models after post-processing by DBS in comparison to the raw model. Accumulated rainfall is substantially improved for the entire period from 47914mm to 58001 mm and from 31286 mm to 60071mm for the NCAR_CCSM4 and NorESM1_M model, respectively, compared to the observed 58104mm of rainfall. The same can be said for other annual statistics. Notably, the DBS procedure is able to reproduce the pattern of rainfall during different seasons. The monsoon season, which accounts for nearly 96% of rainfall (Rana et al., 2012), is well represented in the scaled data. It can be observed in table 2 that there is slight overestimation of rainfall in the post

monsoon season (especially for September), while rainfall in June is underestimated, indicating a delayed onset of the Monsoon season in the GCMs (see also Figure 1). It can also be inferred from Figure 1 that the DBS methodology is not able to correct this late onset of the monsoon in the GCMs, and the case may be the same when we are analysing future projections. The systematic error in the monsoon onset can be attributed to biases in the GCM data and not in the DBS methodology. This can also be observed for individual months during the monsoon season where they show a slight correctional shift in the amount of rainfall received compared to observed data. The percentage of annual rainfall occurring during the monsoon months is corrected quite well in the scaled data, which was 85.1% and 85% respectively in the raw NCAR_CCSM4 and NorESM1_M projections, after DBS these increase to 94.3% and 95.1% compared to 95.8% of the observed values over monsoon season. The difference can be attributed to bias in raw GCM data.

Extreme value statistics are represented in Table 3 and Figure 2 for 1, 2, 3 and 7 consecutive days. In the case of raw GCM data the extremes are below the observed values, (Figure 2), which is to be expected considering the differing spatial scales. It can be observed from the table that the mean (153mm) and standard deviation (42.2mm) of extreme events for all the observed data (1 day maximum) are well represented in the DBS corrected GCM data which is 154mm and 45.8mm respectively for the NCAR_CCSM4, 139.9mm and 51.2mm respectively for the NorESM1_M model. The same can be observed for 2, 3 and 7-day maximum values where there is marked improvement in the statistics after the scaling procedure. Lognormal and Gumbel distribution fitting to the data with return periods of 50 and 100 years represents realistic values. One day log normal values for the 50 (284 mm) and 100 (309.6mm) year return periods are well represented in the scaled data with 282 and 307mm for the NCAR_CCSM4 and 285 and 316mm for the NorESM1_M model respectively. Similarly, the 1 day Gumbel distribution values for the 50 (263 mm) and 100 (286mm) year return periods are well represented in the scaled data with 272 and 297mm for the NCAR_CCSM4 and 272 and 300mm for the NorESM1_M model respectively.

The rainfall intensity histogram for the entire reference period is presented in Figure 3. The raw GCM data show a lower number of dry days (i.e. days with no rainfall), they generally overestimate the frequency in the intensity interval of 0-20mm, and underestimate the frequency of intensities above 40mm. This is an expected consequence of the difference in spatial scales between the data sets, but may also reflect GCM bias. In contrast, the rainfall intensity histogram of the DBS corrected model data closely follows that of the observed data for both models. High intensity/frequency events (more than 80mm/day) in the scaled data are apparent and are in line with the observed data.

3.2 Evaluation for climate projections for the near future (2010-2040), intermediate future (2041-2070) and distant future (2071-2099).

All the calculated statistics, including mean, standard deviation and coefficient of variation, for annual, pre-monsoon, monsoon, post monsoon and winter seasons along with other months are presented in Appendix 2 and only representative statistics for near future projections are presented in Table 4. Readers are referred to appendix 2 for details of statistics for intermediate and distant future projections.

3.2.1 The near future projection

In Table 4, climate statistics for near future projections are presented for only annual, pre-monsoon, monsoon, post monsoon and winter seasons, all other months are listed in appendix 2. It should be noted that all the projections are indicating an increase in mean annual rainfall as compared to the observed baseline mean of 1936 mm. The ensemble mean suggests there is an of around ~140mm in rainfall for the city with a range of -18mm -500mm for the different projections. Similar changes can be observed in the monsoon season for all the projections. There are relatively small changes in the coefficient of variation which is 22.9% and 27.2% for the annual and monsoon season as compared to 19.1% and 18.7% for the observed baseline projection suggesting slightly higher variability in the near future. Figure 4 represents the percentage contribution by the DBS corrected model data as compared to the observed reference data in months during the monsoon season. It can be observed that all the DBS corrected projections project a lower rainfall contribution during June, approximately the same during July and a higher rainfall contribution in the months of August and September as compared to the observed values which are relatively high in July-August and low in June and September. This can be attributed to a bias in the raw GCM data as was indicated in Figure 1. The overall percentage contribution to the monsoon season is relatively conserved in comparison to the reference data with an increase in the total rainfall received.

3.2.2 The intermediate future projection

All the projections indicate an increase in mean annual rainfall as compared to the observed mean value of 1936mm. The ensemble mean suggests an increase of around 300mm in rainfall for the city and the same can be observed in the monsoon season for all the projections. There is a relatively larger change (when compared to the near future projections) in percentage coefficient of variation which is 30.7% and 31.3% for the annual and the monsoon season as compared to 19.1% and 18.7% for the observed baseline projection suggesting a higher variability than that observed in near future projections. The percentage contribution by the DBS corrected model data in the intermedeate future as compared to observed reference data is presented in Figure 5 for the monsoon season. It can be pointed out that all the models are suggesting a lower rainfall contribution during June, approximately the same during July and a higher rainfall contribution in the months of August and September, similar to what was observed in the near future projection. This again is attributed to the bias in raw GCM data (Figure 1). The overall percentage contribution to monsoon season is relatively conserved in comparison to the baseline data and is not increasing.

3.2.3 The distant future projection

In Appendix 2, it can be noticed that all the models are indicating an increase in mean annual rainfall as compared to the observed reference mean of 1936 mm where the average of all the models is up to 2350mm. There is a relatively large change when compared to the near future projections and a relatively small change when compared to the intermediate projections in the percentage coefficient of variation, which is reported as 25.6% and 27.2% for the annual and monsoon season. This is close to the observed baseline projection suggesting low variability. Figure 6 represents the percentage contribution during the monsoon season for the DBS corrected model data as compared to observed reference data. It suggests a lower rainfall contribution during June, approximately the same during July and a higher rainfall contribution in the months of August and September as was observed in the reference data (Figure 1), near

future and intermediate future projections. The overall percentage contribution to the monsoon season is relatively well represented in comparison to the reference data. There is also a relative increase in the amount of rainfall received during the monsoon months for all the projection runs.

3.3 Trends in the long term (2010-99) climate projections and evaluation of extreme events for all projections:

A trend analysis for the entire future period is presented in Table 5 and extreme values are depicted in Figure 7. It can be observed from table 5 that 4 out of 9 models are suggesting a significant positive trend in the extreme rainfall, including the BCC_CSM1.1, INM_CM4, NCAR_CCSM4 and the NorESM1_M models with total daily (one day) mean maximums up to 160mm for all the models. Three out of nine projections show a decreasing trend but these are not significant at the 0.05 level. It should also be noted that the average of all the projections point towards a positive trend in daily events in both the student t-test and Mann-Kendall analyses. It should also be noted that six out of nine projections are indicating a positive trend in maximum daily rainfall. Figure 7 shows an average maximum rainfall for the 50 year return period as 310mm and 295 mm using log normal and Gumbel distributions and 340mm and 325 mm for 100 year return periods. The maxima (T50 and T100) range from 250-375mm for different models. This is relatively higher than the observed values. Figures 8 represent the trends of daily maximum rainfall as estimated by the different projections; It can be observed from the figure that most of the models show a positive trend except CanESM1.1, CERFACS_CNRM_CM5 and MPI_ESM_LR, as was observed in table 5.

Figure 7 represents the extreme values for the 50- and 100-year return periods using log normal and Gumbel Distribution functions for all the projections. It is evident from Figure 7 that the intensity of rainfall, which is already relatively high when compared to observed values, are projected to increase in the future. The increase in rainfall intensity is about ~15-20% in all the 30 time slice projections (Appendix 2) and ~30-45% in 90 year transient projection. This can also be inferred from Figure 7 where a comparison has been performed with respect to the intensity values for the 50 and 100 year return period durations for all the projection runs. These results can be associated with an increased hydrological risk for the city of Mumbai, as was investigated by (Rana et al., 2013). The authors have developed IDF curves and calculated the risks associated using historical data. The projections presented here could provide valuable information for risk management and climate adaptation planning in Mumbai. They can also be used to find out the intensity of storms and relative change in the amount of precipitation received in monsoon season over the study period i.e future projections can serve as important criteria for the design of drainage systems and other infrastructure facilities. Nevertheless, there are reasonable sources of uncertainties related, mainly, to the climate projections in describing probability of occurrence of extreme events. Further, due to the nature of extreme events, there is only limited data available, the inherent natural or internal variability add uncertainty to the analysis of the results. The uncertainties can also be attributed to GCM data; Figure 1 shows an example of one such bias. Scaling methodologies like DBS can be used effectively in climate studies with associated uncertainties for regions which still lack high spatial resolution data as in case of Mumbai. This provides a simple and convenient alternative to complex bias correction and scaling methodologies. Also, the model ensemble range can provide an estimate of the uncertainty related to model structures and internal variability. A large ensemble of climate model outputs driven by different models help in quantifying the uncertainties and reduce errors

associated with them. This also helps in more comprehensive and complete analysis of the effects of climate change with greater insight to the range of different model and scaling uncertainties.

It is interesting to note the significant positive trends shown by most of the models in the different projections. Different models suggest different trends during the periods analysed including a positive trend in the transient projection where 2010-99 data is analysed. This calls for the attention of planners and managers to make suitable adjustments in the collection and drainage systems of Mumbai keeping in mind the future projections for the area. The projections can be used in management and planning of the city and formulating the policies accordingly. Planners now have a handy analysis of future projections for decision making, based on level of performance or acceptable level of risk, regarding the desired infrastructure systems.

4. Concluding remarks

Main findings of the present study are outlined below:

1. Comparison of point observations in Mumbai with raw GCM projections in the reference period shows that GCMs underestimate the precipitation statistics in the study area.
2. After the application of DBS, the agreement in the reference period becomes quite good and the climate signal in the observed reference data is preserved. Thus, DBS has proved capable of improving the representation of local rainfall statistics.
3. Results have indicated an increased amount of precipitation received in the study area in all future climatic projections. The increase in the amount of precipitation ranges from -20-40% in various projections.
4. The same can be said about extreme events of rainfall as tested for the 50 and 100-year return periods using Lognormal and Gumbel distribution functions. The increase in the extreme events range from 0-40%.
5. DBS corrected GCM models have indicated positive trends of extreme rainfall in the long-term projections (2010-99). 6 out of 9 models show a positive trend including 4 showing a significant trend at the 0.05 level for both the trend analyses.

The method is suitable for dealing with scaling of poor GCM data at the regional scale. While the projections presented in this study are indicative of the expected range of rainfall changes, it must be noted that the quantitative estimates still have uncertainties associated with them. The uncertainties associated may also be because of inability of the DBS method to perfectly resolve the bias in the onset of monsoon season in the study area and the high rainfall in September. It has been noted that raw GCM data had a delayed monsoon season with high rainfall in September that is not found in the observed data. Improvements are still required in climate model post-processing methodologies to deal with such substantial biases, e.g. related to inaccurate timing and location of stationary synoptic-scale rainfall fields like the monsoon. There are indeed developments in studying the impact of climate change at the regional scale but options need to be explored further for reduction of uncertainties associated with GCM data and scaling procedures.

The results of the present study, using scaling techniques to scale GCM projections to the regional scale, should be seen as an improvement to impact studies.. In urban areas, it is very important to study the effects of extreme events and increases in net rainfall and rainfall-runoff relationships. Changes in the physical characteristics of urban areas change the runoff response of the area along with natural forces. Thus, it is necessary to evaluate the effect of changes in rainfall and human interference on the natural drainage patterns of the urban area. Infrastructural

planning of urban areas should require careful attention to urban drainage characteristics. This study could be useful for adaptation studies in future for the study area.

Acknowledgment

The authors would like to acknowledge the World Climate Research Programme's Working Group on Coupled Modelling, which is responsible for CMIP, and we thank the climate modelling groups (listed in Table 1 of this paper) for producing and making available their model outputs. For CMIP the U.S. Department of Energy's Program for Climate Model Diagnosis and Intercomparison provides coordinating support and led development of software infrastructure in partnership with the Global Organization for Earth System Science Portals. Funding from the Swedish Research Council Formas and the Swedish International Development Agency (SIDA) is gratefully acknowledged.

References

- Annamalai, H., Hamilton, K., Sperber, K.R., 2007. The South Asian Summer Monsoon and Its Relationship with ENSO in the IPCC AR4 Simulations. *J. Clim.*, 20(6): 1071-1092.
- Ashley, R.M., Balmforth, D.J., Saul, A.J., Blankby, J.D., 2005. Flooding in the future - predicting climate change, risks and responses in urban areas. *Water Sci. Technol.*, 52(5): 265-273.
- Bergstrom, S., 2001. Climate change impacts on runoff in Sweden-assessments by global climate models, dynamical downscaling and hydrological modelling. *Clim. Res.*, 16(2): 101.
- Boé, J., Terray, L., Habets, F., Martin, E., 2007. Statistical and dynamical downscaling of the Seine basin climate for hydro-meteorological studies. *International Journal of Climatology*, 27(12): 1643-1655.
- Chen, H., Guo, S., Xu, C.-y., Singh, V.P., 2007. Historical temporal trends of hydro-climatic variables and runoff response to climate variability and their relevance in water resource management in the Hanjiang basin. *J. Hydrol.*, 344(3-4): 171-184.
- Chen, H., Xu, C.-Y., Guo, S., 2012. Comparison and evaluation of multiple GCMs, statistical downscaling and hydrological models in the study of climate change impacts on runoff. *J. Hydrol.*, 434-435(0): 36-45.
- Dash, S.K., Kulkarni, M.A., Mohanty, U.C., Prasad, K., 2009. Changes in the characteristics of rain events in India. *Journal of Geophysical Research: Atmospheres*, 114(D10): D10109.
- Fan, F., Mann, M.E., Lee, S., Evans, J.L., 2010. Observed and Modeled Changes in the South Asian Summer Monsoon over the Historical Period*. *J. Clim.*, 23(19): 5193-5205.
- Fowler, H.J., Blenkinsop, S., Tebaldi, C., 2007. Linking climate change modelling to impacts studies: recent advances in downscaling techniques for hydrological modelling. *International Journal of Climatology*, 27(12): 1547-1578.
- Frei, C., Schär, C., Lüthi, D., Davies, H.C., 1998. Heavy precipitation processes in a warmer climate. *Geophys. Res. Lett.*, 25(9): 1431-1434.
- Frei, C., Schöll, R., Fukutome, S., Schmidli, J., Vidale, P.L., 2006. Future change of precipitation extremes in Europe: Intercomparison of scenarios from regional climate models. *J. Geophys. Res.*, 111(D6): D06105.
- Gadgil, A., Dhorde, A., 2005. Temperature trends in twentieth century at Pune, India. *Atmos. Environ.*, 39(35): 6550-6556.
- Goswami, B.N., Venugopal, V., Sengupta, D., Madhusoodanan, M.S., Xavier, P.K., 2006. Increasing Trend of Extreme Rain Events Over India in a Warming Environment. *Science*, 314(5804): 1442-1445.

- Graham, L., Hagemann, S., Jaun, S., Beniston, M., 2007. On interpreting hydrological change from regional climate models. *Clim. Change*, 81(0): 97-122.
- Guo, S., Wang, J., Xiong, L., Ying, A., Li, D., 2002. A macro-scale and semi-distributed monthly water balance model to predict climate change impacts in China. *J. Hydrol.*, 268(1-4): 1-15.
- Haylock, M.R. et al., 2006. Trends in total and extreme South American rainfall in 1960-2000 and links with sea surface temperature. *J. Clim.*, 19(8): 1490-1512.
- Huntingford, C., Hugo Lambert, F., Gash, J.H.C., Taylor, C.M., Challinor, A.J., 2005. Aspects of climate change prediction relevant to crop productivity. *Philosophical Transactions of the Royal Society B: Biological Sciences*, 360(1463): 1999-2009.
- Huntington, T.G., 2006. Evidence for intensification of the global water cycle: Review and synthesis. *J. Hydrol.*, 319(1-4): 83-95.
- Kao, S.-C., Ganguly, A.R., 2011. Intensity, duration, and frequency of precipitation extremes under 21st-century warming scenarios. *J. Geophys. Res.*, 116(D16): D16119.
- Kay, A.L., Reynard, N.S., Jones, R.G., 2006. RCM rainfall for UK flood frequency estimation. I. Method and validation. *J. Hydrol.*, 318(1-4): 151-162.
- Kharin, V.V., Zwiers, F.W., Zhang, X., Hegerl, G.C., 2007. Changes in Temperature and Precipitation Extremes in the IPCC Ensemble of Global Coupled Model Simulations. *J. Clim.*, 20(8): 1419-1444.
- Kotlarski, S., 2005. Regional climate model simulations as input for hydrological applications: evaluation of uncertainties. *Advances in geosciences*, 5: 119.
- Kripalani, R.H., Kulkarni, A., Sabade, S.S., Khandekar, M.L., 2003. Indian Monsoon Variability in a Global Warming Scenario. *Nat. Hazards*, 29(2): 189-206.
- Kripalani, R.H., Oh, J.H., Kulkarni, A., Sabade, S.S., Chaudhari, H.S., 2007. South Asian summer monsoon precipitation variability: Coupled climate model simulations and projections under IPCC AR4. *Theor. Appl. Climatol.*, 90(3-4): 133-159.
- Krishnan, R. et al., 2013. Will the South Asian monsoon overturning circulation stabilize any further? *Climate Dynamics*, 40(1-2): 187-211.
- Kumar, K.K. et al., 2011. The once and future pulse of Indian monsoonal climate. *Climate Dynamics*, 36(11-12): 2159-2170.
- Kumke, T., 2001. Book Review: *Regional Frequency Analysis: An Approach Based on L-Moments* By J. R. M. Hosking and J. R. Wallis Cambridge University Press, Cambridge, UK, 1997, 224 p., \$69.95 (U.S.), ISBN 0-521-43045-3 hardback. *Mathematical Geology*, 33(4): 535-537.
- Lal, M., Meehl, G.A., Arblaster, J.M., 2000. Simulation of Indian summer monsoon rainfall and its intraseasonal variability in the NCAR climate system model. *Reg Environ Change*, 1(3-4): 163-179.
- Lenderink, G., 2007. Estimates of future discharges of the river Rhine using two scenario methodologies: direct versus delta approach. *Hydrol. Earth Syst. Sci.*, 11(3): 1145.
- Mailhot, A., Duchesne, S., Caya, D., Talbot, G., 2007. Assessment of future change in intensity-duration-frequency (IDF) curves for Southern Quebec using the Canadian Regional Climate Model (CRCM). *J. Hydrol.*, 347(1-2): 197-210.
- Majumdar, K.C., Sawhney, R.P., 1965. Estimates of extreme values by different distribution functions. *Water Resour Res*, 1(3): 429-434.
- Maraun, D. et al., 2010. Precipitation downscaling under climate change: Recent developments to bridge the gap between dynamical models and the end user. *Rev. Geophys.*, 48(3): RG3003.
- May, W., 2002. Simulated changes of the Indian summer monsoon under enhanced greenhouse gas conditions in a global time-slice experiment. *Geophys. Res. Lett.*, 29(7): 22-1-22-4.
- May, W., 2004. Simulation of the variability and extremes of daily rainfall during the Indian summer monsoon for present and future times in a global time-slice experiment. *Climate Dynamics*, 22(2-3): 183-204.
- May, W., 2011. The sensitivity of the Indian summer monsoon to a global warming of 2°C with respect to pre-industrial times. *Climate Dynamics*, 37(9-10): 1843-1868.

- McKibben, B., 2007. Climate change 2007: The physical science basis: Summary for policymakers (vol 54, pg 44, 2007). New York Rev Books, 54(8): 58-58.
- Meehl, G.A., Arblaster, J.M., 2003. Mechanisms for projected future changes in south Asian monsoon precipitation. *Climate Dynamics*, 21(7-8): 659-675.
- Mehdi, B., Mrena, C., and Douglas, A., 2006. Adapting to climate change: An introduction for Canadian Municipalities, Canadian Climate Impacts and Adaptation Research Network (C-CIARN).
- Min, S.-K., Zhang, X., Zwiers, F.W., Hegerl, G.C., 2011. Human contribution to more-intense precipitation extremes. *Nature*, 470(7334): 378-381.
- Mitchell, J.M.J. et al., 1966. Climate Change, World Meteorological Organisation, Geneva, Switzerland.
- Naidu, C.V., Rao, B.R.S., Rao, D.V.B., 1999. Climatic trends and periodicities of annual rainfall over India. *Meteorol. Appl.*, 6(4): 395-404.
- Parthasarathy, B., Kumar, K.R., Munot, A.A., 1993. HOMOGENEOUS INDIAN MONSOON RAINFALL - VARIABILITY AND PREDICTION. *Proc. Indian Acad. Sci.-Earth Planet. Sci.*, 102(1): 121-155.
- Pinto, J.G., Neuhaus, C.P., Leckebusch, G.C., Reyers, M., Kerschgens, M., 2010. Estimation of wind storm impacts over Western Germany under future climate conditions using a statistical-dynamical downscaling approach. *Tellus A*, 62(2): 188-201.
- Ramesh Kumar, M.R., Krishnan, R., Sankar, S., Unnikrishnan, A.S., Pai, D.S., 2009. Increasing Trend of Break-Monsoon Conditions Over India; Role of Ocean-Atmosphere Processes in the Indian Ocean. *Geoscience and Remote Sensing Letters, IEEE*, 6(2): 332-336.
- Rana, A., Bengtsson, L., Olsson, J., Jothiprakash, V., 2013. Development of IDF-curves for tropical india by random cascade modeling. *Hydrol. Earth Syst. Sci. Discuss.*, 10(4): 4709-4738.
- Rana, A., Uvo, C., Bengtsson, L., Parth Sarthi, P., 2012. Trend analysis for rainfall in Delhi and Mumbai, India. *Climate Dynamics*, 38(1): 45-56.
- Rupakumar, K. et al., 2006. High-resolution climate change scenarios for India for the 21st century. *Curr. Sci.*, 90: 334-345.
- Sabade, S.S., Kulkarni, A., Kripalani, R.H., 2011. Projected changes in South Asian summer monsoon by multi-model global warming experiments. *Theor. Appl. Climatol.*, 103(3-4): 543-565.
- Schoof, J.T. et al., 2009. Dynamically and statistically downscaled seasonal temperature and precipitation hindcast ensembles for the southeastern USA. *International Journal of Climatology*, 29(2): 243-257.
- Semenov, V.S., Bengtsson, L.B., 2002. Secular trends in daily precipitation characteristics: greenhouse gas simulation with a coupled AOGCM. *Climate Dynamics*, 19(2): 123-140.
- Stainforth, D.A., Downing, T.E., Washington, R., Lopez, A., New, M., 2007. Issues in the interpretation of climate model ensembles to inform decisions. *Philosophical Transactions of the Royal Society A: Mathematical, Physical and Engineering Sciences*, 365(1857): 2163-2177.
- Stowasser, M., Annamalai, H., Hafner, J., 2009. Response of the South Asian Summer Monsoon to Global Warming: Mean and Synoptic Systems*. *J. Clim.*, 22(4): 1014-1036.
- Teutschbein, C., Wetterhall, F., Seibert, J., 2011. Evaluation of different downscaling techniques for hydrological climate-change impact studies at the catchment scale. *Climate Dynamics*, 37(9): 2087-2105.
- Trenberth, K.E., 1999. Atmospheric Moisture Recycling: Role of Advection and Local Evaporation. *J. Clim.*, 12(5): 1368-1381.
- Turner, A.G., Hannachi, A., 2010. Is there regime behavior in monsoon convection in the late 20th century? *Geophys. Res. Lett.*, 37(16): L16706.
- Ueda, H., Iwai, A., Kuwako, K., Hori, M.E., 2006. Impact of anthropogenic forcing on the Asian summer monsoon as simulated by eight GCMs. *Geophys. Res. Lett.*, 33(6): L06703.
- WCRP, 2011. Coupled Model Intercomparison Project – Phase 5, Special Issue of the CLIVAR Exchanges Newsletter, No. 56.

- Wilby, R.L., Hay, L.E., Leavesley, G.H., 1999. A comparison of downscaled and raw GCM output: implications for climate change scenarios in the San Juan River basin, Colorado. *J. Hydrol.*, 225(1–2): 67-91.
- Wilby, R.L., Wigley, T.M.L., 2002. Future changes in the distribution of daily precipitation totals across North America. *Geophys. Res. Lett.*, 29(7): 1135.
- Willems, P., Arnbjerg-Nielsen, K., Olsson, J., Nguyen, V.T.V., 2012. Climate change impact assessment on urban rainfall extremes and urban drainage: Methods and shortcomings. *Atmos. Res.*, 103(0): 106-118.
- Willems, P., Vrac, M., 2011. Statistical precipitation downscaling for small-scale hydrological impact investigations of climate change. *J. Hydrol.*, 402(3–4): 193-205.
- Xu, C.-y., 2000. Modelling the Effects of Climate Change on Water Resources in Central Sweden. *Water Resources Management*, 14(3): 177-189.
- Xu, C.-y., Widén, E., Halldin, S., 2005. Modelling hydrological consequences of climate change—Progress and challenges. *Advances in Atmospheric Sciences*, 22(6): 789-797.
- Yang, W. et al., 2010. Distribution-based scaling to improve usability of regional climate model projections for hydrological climate change impacts studies. *Hydrology Research*, 41(3/4): 211-229.

Table 1: List of CMIP5 GCMs used in present study

Modeling Centre	Model	Institution
BCC	BCC_CSM1.1	Beijing Climate Center, China Meteorological Administration
CCCma	CanESM1.1	Canadian Centre for Climate Modelling and Analysis
INM	INM_CM4	Institute for Numerical Mathematics
IPSL	IPSL_CM5A_MR	Institut Pierre-Simon Laplace
NCAR	NCAR_CCSM4	National Center for Atmospheric Research
NCC	NorESM1_M	Norwegian Climate Centre
CNRM-CERFACS	CERFACS_CNRM_CM5	Centre National de Recherches Meteorologiques / Centre Europeen de Recherche et Formation Avancees en Calcul Scientifique
MPI-M	MPI_ESM_LR	Max Planck Institute for Meteorology (MPI-M)
MOHC	HadGEM2_ES	Met Office Hadley Centre

Table 2: Climate Statistics of Observed data, GCM raw data and DBS corrected GCM data

			Annual	June	July	August	September	Pre-Monsoon	Southwest Monsoon	Post Monsoon	Winter
Observed		Rainfall accumulated	58104.0	7807.0	20547.0	16380.0	8826.0	30.0	53560.0	4336.0	90.0
		Mean	1936.8	260.2	684.9	546.0	294.2	1.0	1785.3	144.5	3.0
		Standard Deviation	369.9	210.9	217.4	251.5	150.2	2.9	334.4	150.6	5.1
		CV (%)	19.1	81.0	31.7	46.1	51.0	285.3	18.7	104.2	170.9
		Percentage to annual	100.0	13.4	35.4	28.2	15.2	0.1	92.2	7.5	0.2
NCAR_CCSM4	Raw Data	Rainfall accumulated	47914.0	5290.0	13795.0	13365.0	8334.0	835.0	40784.0	4608.0	1530.0
		Mean	1597.1	176.3	459.8	445.5	277.8	27.8	1359.5	153.6	51.0
		Standard Deviation	254.0	139.6	150.3	150.0	118.6	26.3	254.5	58.8	37.1
		CV (%)	15.9	79.2	32.7	33.7	42.7	94.3	18.7	38.3	72.8
		Percentage to annual	100.0	11.0	28.8	27.9	17.4	1.7	85.1	9.6	3.2
	DBS Corrected	Rainfall accumulated	58001.0	6833.0	19066.0	18159.0	10664.0	500.0	54722.0	1841.0	827.0
		Mean	1933.4	227.8	635.5	605.3	355.5	16.7	1824.1	61.4	27.6
		Standard Deviation	428.6	225.7	256.1	248.3	192.6	44.9	425.6	62.1	31.7
		CV (%)	22.2	99.1	40.3	41.0	54.2	269.5	23.3	101.3	115.1
		Percentage to annual	100.0	11.8	32.9	31.3	18.4	0.9	94.3	3.2	1.4
NorESM1_M	Raw Data	Rainfall accumulated	31286.0	1763.0	7389.0	10970.0	6460.0	330.0	26582.0	3143.0	1091.0
		Mean	1042.9	58.8	246.3	365.7	215.3	11.0	886.1	104.8	36.4
		Standard Deviation	288.7	58.4	84.8	165.3	94.0	9.9	256.2	63.6	24.7
		CV (%)	27.7	99.4	34.4	45.2	43.7	90.4	28.9	60.7	68.0
		Percentage to annual	100.0	5.6	23.6	35.1	20.6	1.1	85.0	10.0	3.5

	DBS Corrected	Rainfall accumulated	60071.0	3171.0	15558.0	24862.0	13522.0	439.0	57113.0	1618.0	794.0
		Mean	2002.4	105.7	518.6	828.7	450.7	14.6	1903.8	53.9	26.5
		Standard Deviation	687.0	140.7	216.4	433.5	231.5	29.6	657.8	64.6	33.4
		CV (%)	34.3	133.1	41.7	52.3	51.4	202.3	34.6	119.8	126.2
		Percentage to annual	100.0	5.3	25.9	41.4	22.5	0.7	95.1	2.7	1.3

Table 3: Extreme Value Statistics of Observed, raw GCM and DBS corrected GCM annual maxima with Lognormal and Gumbel distributions.

Distribution				Log Normal		Gumbel	
Model	Time Step	Mean	Standard Deviation	T50	T100	T50	T100
Observed	Daily Max	153.6	42.2	284.0	309.6	263.0	286.0
	2 day Max	244.6	66.4	451.6	492.4	416.6	452.7
	3 Day Max	308.5	73.2	573.8	625.5	498.3	538.1
	7 Day Max	478.1	106.9	893.0	973.5	755.3	813.5
Raw NCAR_CCSM4	Daily Max	96.8	36.4	201.5	224.3	191.1	211.0
	2 day Max	149.6	52.8	309.4	343.9	286.5	315.2
	3 Day Max	183.5	64.1	365.8	404.4	349.5	384.4
	7 Day Max	268.7	78.2	491.3	535.6	471.5	514.0
DBS Corrected NCAR_CCSM4	Daily Max	154.2	45.8	282.0	307.4	272.8	297.7
	2 day Max	244.8	74.3	475.4	523.0	437.5	478.0
	3 Day Max	299.7	96.5	579.8	637.8	549.9	602.4
	7 Day Max	426.3	128.3	808.3	886.0	759.0	828.9
Raw NorESM1_M	Daily Max	53.2	20.7	106.3	117.6	106.8	118.1
	2 day Max	88.3	35.0	174.5	192.7	179.1	198.1
	3 Day Max	110.7	44.0	211.6	232.6	224.7	248.7
	7 Day Max	174.1	65.0	320.1	349.7	342.6	378.0
DBS Corrected NorESM1_M	Daily Max	139.9	51.2	285.0	316.1	272.7	300.6
	2 day Max	232.8	90.0	480.7	534.5	466.1	515.1
	3 Day Max	287.9	115.7	581.2	644.2	587.8	650.7
	7 Day Max	435.5	177.4	864.2	955.6	895.4	992.0

Table 4: Climate Statistics for near future DBS corrected GCM projections (2010-2040). The values in brackets represent the relative change in the DBS corrected GCM data when comparing the near future and the reference period i.e DBS-GCM (2010-40) – DBS-GCM (1979-2004).

Month/Season		Annual	Pre- Monsoon	Southwest Monsoon	Post Monsoon	Winter

BCC_CSM1.1	Mean	2024.5 (0.7)	20.5 (5.1)	1592.0 (-338.0)	391.2 (343.4)	2092.1 (2064.7)
	Standard Deviation	8.8 (-458.7)	34.2 (-3.9)	512.6 (58.1)	265.3 (220.4)	716.7 (679.6)
	CV (%)	0.4 (-22.7)	166.9 (-81.0)	32.2 (8.6)	67.8 (-26.1)	34.3 (-101.2)
CanESM1.1	Mean	2040.5 (124.7)	20.5 (3.9)	1927.3 (113.8)	69.3 (15.4)	34.7 (6.0)
	Standard Deviation	566.7 (-141.8)	34.2 (0.6)	551.2 (-141.7)	68.3 (3.9)	76.9 (36.0)
	CV (%)	27.8 (-9.2)	166.9 (-35.2)	28.6 (-9.6)	98.5 (-21.0)	221.8 (79.1)
INM_CM4	Mean	2388.2 (209.5)	20.5 (3.5)	2224.1 (174.8)	52.3 (-10.0)	72.6 (26.2)
	Standard Deviation	706.3 (73.5)	34.2 -15.5)	664.9 (59.3)	66.9 (-19.5)	68.4 (20.5)
	CV (%)	29.6 (0.5)	166.9 (-125.5)	29.9 (0.3)	127.9 (-10.7)	94.3 (-8.9)
IPSL_CM5A_MR	Mean	2347.5 (-18.6)	20.5 (7.8)	2220.6 (-38.2)	77.6 (32.4)	28.6 (-17.6)
	Standard Deviation	610.8 (-98.4)	34.2 (7.1)	625.0 (-60.9)	96.2 (35.2)	47.9 (-4.3)
	CV (%)	26.0 (-4.0)	166.9 (-47.1)	28.1 (-2.2)	124.0 (-11.1)	167.5 (54.4)
NCAR_CCSM4	Mean	2132.0 (198.7)	20.5 (3.8)	2023.9 (199.8)	65.6 (4.2)	26.1 (-1.4)
	Standard Deviation	407.1 (-21.5)	34.2 (-10.7)	406.3 (-19.3)	68.2 (6.1)	22.3 (-9.5)
	CV (%)	19.1 (-3.1)	166.9 (-102.5)	20.1 (-3.3)	104.0 (2.7)	85.1 (-29.9)
NorESM1_M	Mean	2016.3 (13.9)	20.5 (5.8)	1923.7 (20.0)	52.6 (-1.4)	29.1 (2.6)
	Standard Deviation	585.7 (-101.3)	34.2 (4.6)	587.9 (-69.9)	62.6 (-2.0)	37.0 (3.6)
	CV (%)	29.0 (-5.3)	166.9 (-35.3)	30.6 (-4.0)	119.1 (-0.7)	127.2 (1.0)
CERFACS_CNRM_CM5	Mean	2074.6 (123.5)	20.5 (4.4)	1921.1 (55.3)	71.1 (8.2)	16.5 (12.5)
	Standard Deviation	450.1 (0.5)	34.2 (-3.0)	435.5 (-3.0)	89.6 (-10.6)	35.2 (25.8)
	CV (%)	21.7 (-1.3)	166.9 (-64.7)	22.7 (-0.8)	126.1 (-33.4)	214.0 (-24.0)
MPL_ESM_LR	Mean	2243.5 (34.2)	20.5 (7.9)	2141.8 (11.4)	83.2 (27.0)	8.5 (0.8)
	Standard Deviation	506.5 (15.2)	34.2 (-1.9)	487.1 (-10.3)	79.4 (25.0)	12.6 (-7.9)
	CV (%)	22.6 (0.3)	166.9 (-121.1)	22.7 (-0.6)	95.5 (-1.5)	148.7 (-118.7)
HadGEM2_ES	Mean	2547.1 (491.4)	20.5 (5.2)	2479.5 (512.3)	41.0 (-18.7)	8.4 (-2.3)
	Standard Deviation	772.4 (166.7)	34.2 (-0.2)	741.9 (143.5)	68.7 (1.4)	21.2 (2.6)
	CV (%)	30.3 (0.8)	166.9 (-58.0)	29.9 (-0.5)	167.6 (54.9)	251.9 (77.7)
Average	Mean	2201.6 (130.9)	20.5 (5.3)	2050.4 (79.0)	100.4 (44.5)	257.4 (232.4)
	Standard Deviation	512.7 (-62.9)	34.2 (-2.6)	556.9 (-4.9)	96.1 (28.9)	115.3 (82.9)

	CV (%)	22.9 (-4.9)	166.9 (-74.5)	27.2 (-1.3)	114.5 (-5.2)	149.4 (-7.8)
--	--------	-------------	---------------	-------------	--------------	--------------

Table 5: Extreme event statistics and trend analysis for the period 2010-2099 using both a student t test and a Mann Kendall test (figures in bold are significant at the 0.05 level).

Model	Mean	Standard Deviation	Regression Slope	Intercept	Correlation Coefficient	Student t	Mann-kendall Test (Z)
BCC_CSM1.1	153.867	53.195	0.406	135.409	0.198	1.907	1.984
CanESM1.1	163.211	51.067	-0.327	178.082	-0.166	-1.591	-1.283
INM_CM4	149.768	56.168	0.463	128.681	0.214	2.07	1.886
IPSL_CM5A_MR	158.282	61.288	0.16	151.024	0.068	0.01	0.342
NCAR_CCSM4	178.532	56.723	0.519	154.94	0.237	2.306	2.92
NorESM1_M	148.256	38.559	0.299	134.673	0.201	1.937	2.426
CERFACS_CNRM_CM5	163.538	50.924	-0.2	172.627	-0.102	-0.966	-1.193
MPL_ESM_LR	169.39	50.88	-0.311	183.548	-0.159	-1.518	-1.464
HadGEM2_ES	162.224	50.615	0.128	156.411	0.066	0.01	0.6
Average	160.7853	52.15767	0.126333	155.0439	0.061889	0.462778	0.690889

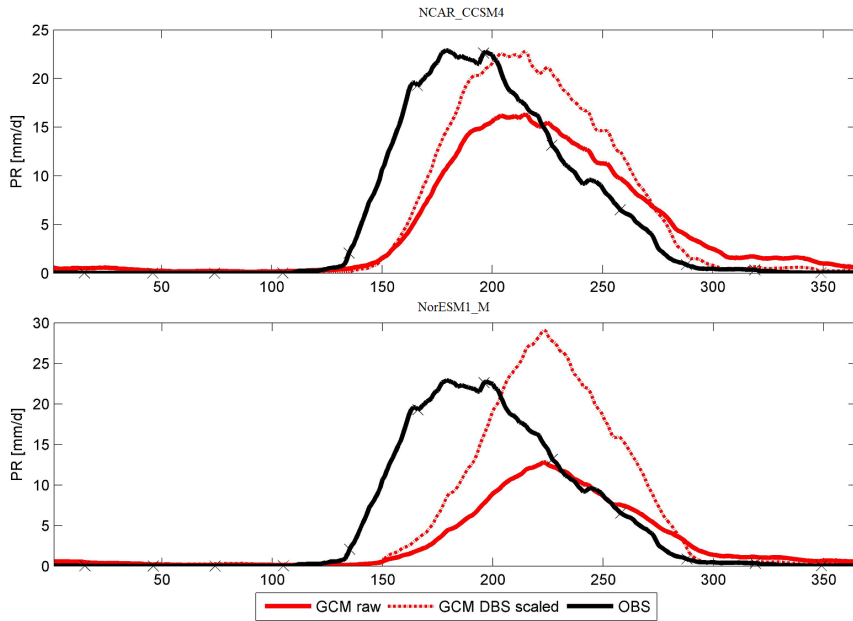

Figure 1: Mean annual rainfall cycle over the 30 year reference period (1975-2004) using a 31 day moving average of the Observed, Raw GCM and DBS corrected GCM data.

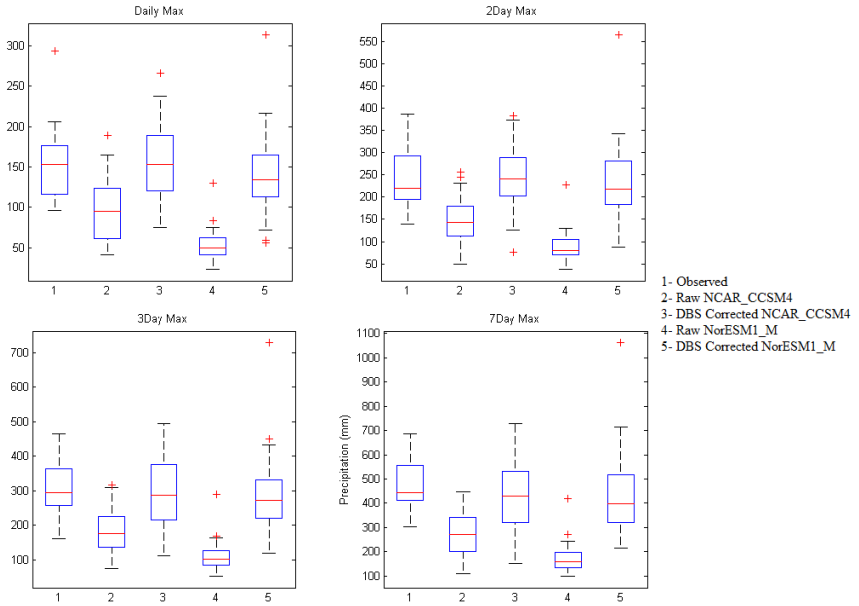

Figure 2: Box plots of Extreme Value Statistics for the Observed, raw GCM and DBS corrected GCM data for 1, 2, 3 and 7-day Maximum values.

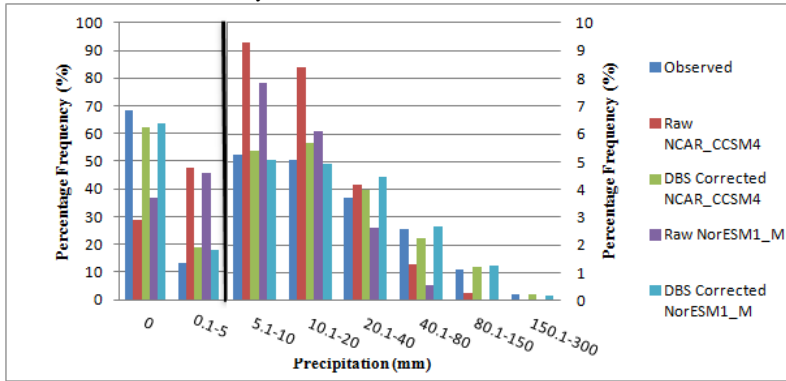

Figure 3: Frequency of rainfall events in the Observed, Raw GCM and DBS corrected GCM data. (Note: The right axis is applicable for the graph to the right of the black vertical line)

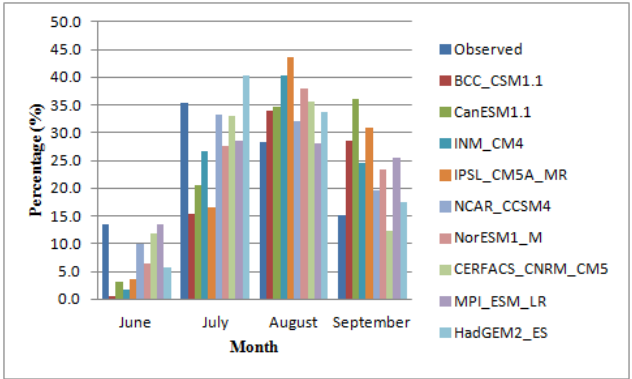

Figure 4: Contribution of near future DBS corrected data (2010-2040) over the monsoon months as compared to observed data during the reference period (1975-2004).

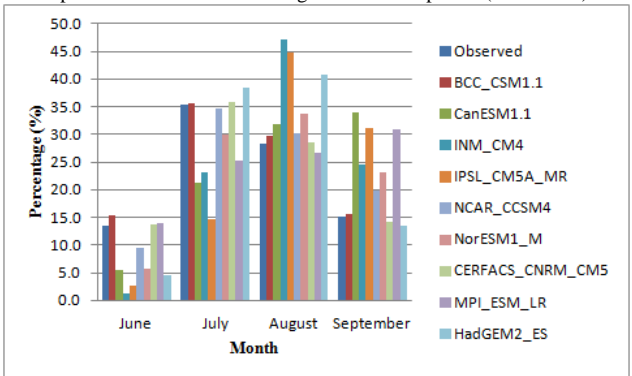

Figure 5: Contribution of intermediate future DBS corrected data (2041-2070) over the monsoon months as compared to observed data during the reference period (1975-2004).

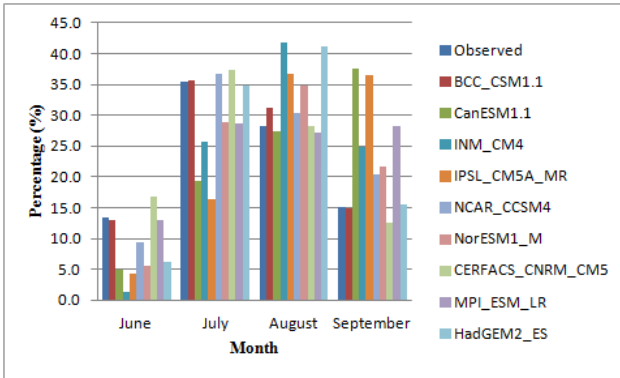

Figure 6: Contribution of distant future DBS corrected data (2071-2100) over the monsoon months as compared to observed data during the reference period (1975-2004).

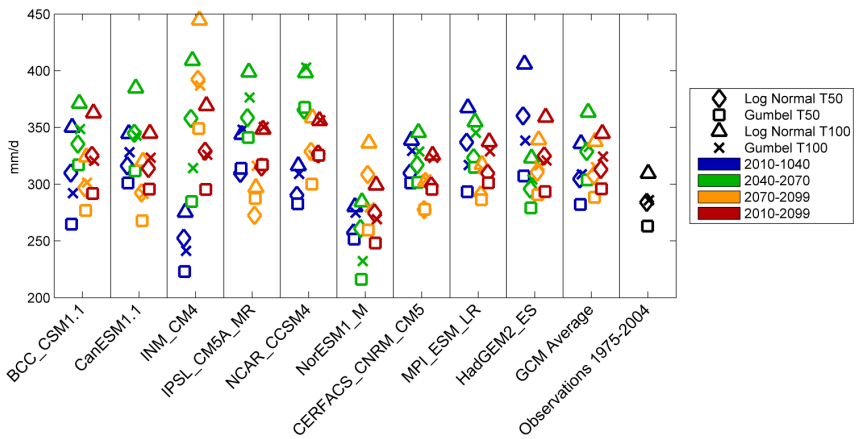

Figure 7: Extreme value statistics for the 50 year and 100 year return periods for the observations, near future (2010-2040), intermediate future (2041-70), distant future (2071-99) and long-term future (2010-99) projections.

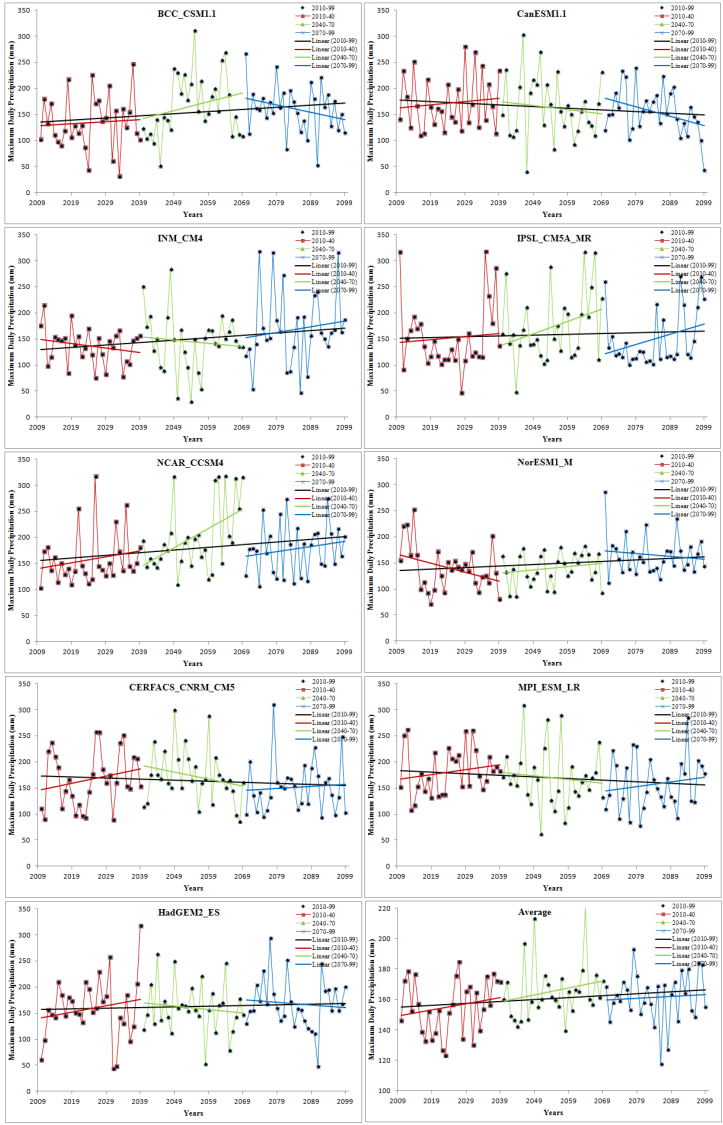

Figure 8: Trends in the daily maximum rainfall in the climate projections; near future (2010-2040), intermediate future (2041-70), distant future (2071-99) and transient future (2010-99).

Appendix 1

Month/ Season			Annual	June	July	August	Septem ber	Pre- Monso on	South west Monso on	Post Mon soon	Wint er
Observ ed		Precipitat ion accumala ted	58104	7807	2054 7	16380	8826	30	53560	4336	90
		Mean	1937	260	685	546	294	1	1785	145	3
		Standard Deviation	370	211	217	252	150	3	334	151	5
		CV (%)	19	81	32	46	51	285	19	104	171
		Percentag e to annual	100	13	35	28	15	0	92	7	0
BCC_C SM1.1	Raw Data	Precipitat ion accumala ted	10144	957	3504	2571	1107	50	8139	1161	676
		Mean	338	32	117	86	37	2	271	39	23
		Standard Deviation	117	49	83	49	64	4	115	31	28
		CV (%)	35	153	71	57	173	243	42	80	122
		Percentag e to annual	100	9	35	25	11	0	80	11	7
	DBS Corr ected	Precipitat ion accumala ted	60713	7244	2246 6	19559	8631	461	57900	1435	820
		Mean	2024	241	749	652	288	15	1930	48	27
		Standard Deviation	467	178	291	207	262	38	454	45	37
		CV (%)	23	74	39	32	91	248	24	94	135
		Percentag e to annual	100	12	37	32	14	1	95	2	1
CanES M1.1	Raw Data	Precipitat ion accumala ted	17987	1002	3425	5500	4627	457	14554	1816	1019
		Mean	600	33	114	183	154	15	485	61	34
		Standard Deviation	223	60	105	92	65	20	199	43	38
		CV (%)	37	180	92	50	42	133	41	71	112
		Percentag e to annual	100	6	19	31	26	3	81	10	6

	DBS Corrected	Precipitation accumulated	57474	3759	12734	19722	18191	498	54406	1617	860
		Mean	1916	125	424	657	606	17	1814	54	29
		Standard Deviation	709	177	356	308	238	34	693	64	41
		CV (%)	37	141	84	47	39	202	38	120	143
		Percentage to annual	100	7	22	34	32	1	95	3	1
INM_CM4	Raw Data	Precipitation accumulated	23418	544	4125	7302	4534	481	16505	4209	2073
		Mean	781	18	138	243	151	16	550	140	69
		Standard Deviation	202	19	95	83	64	9	129	95	54
		CV (%)	26	102	69	34	42	56	23	67	78
		Percentage to annual	100	2	18	31	19	2	70	18	9
	DBS Corrected	Precipitation accumulated	65362	1799	15967	28472	15240	510	61478	1868	1392
		Mean	2179	60	532	949	508	17	2049	62	46
		Standard Deviation	633	90	408	441	239	50	606	86	48
		CV (%)	29	150	77	46	47	292	30	139	103
		Percentage to annual	100	3	24	44	23	1	94	3	2
IPSL_CM5A_MR	Raw Data	Precipitation accumulated	23491	482	2594	9134	6818	125	19028	2848	1375
		Mean	783	16	86	304	227	4	634	95	46
		Standard Deviation	281	19	72	175	86	7	243	67	39
		CV (%)	36	117	83	58	38	179	38	70	84
		Percentage to annual	100	2	11	39	29	1	81	12	6
	DBS Corrected	Precipitation accumulated	70983	2990	11000	30846	22929	379	67765	1355	1386
		Mean	2366	100	367	1028	764	13	2259	45	46
		Standard Deviation	709	87	229	482	242	27	686	61	52

		CV (%)	30	87	62	47	32	214	30	135	113
		Percentage to annual	100	4	15	43	32	1	95	2	2
NCAR_CCS_M4	Raw Data	Precipitation accumulated	47914	5290	13795	13365	8334	835	40784	4608	1530
		Mean	1597	176	460	446	278	28	1359	154	51
		Standard Deviation	254	140	150	150	119	26	254	59	37
		CV (%)	16	79	33	34	43	94	19	38	73
		Percentage to annual	100	11	29	28	17	2	85	10	3
	DBS Corrected	Precipitation accumulated	58001	6833	19066	18159	10664	500	54722	1841	827
		Mean	1933	228	636	605	355	17	1824	61	28
		Standard Deviation	429	226	256	248	193	45	426	62	32
		CV (%)	22	99	40	41	54	269	23	101	115
		Percentage to annual	100	12	33	31	18	1	94	3	1
NorES_M1_M	Raw Data	Precipitation accumulated	31286	1763	7389	10970	6460	330	26582	3143	1091
		Mean	1043	59	246	366	215	11	886	105	36
		Standard Deviation	289	58	85	165	94	10	256	64	25
		CV (%)	28	99	34	45	44	90	29	61	68
		Percentage to annual	100	6	24	35	21	1	85	10	3
	DBS Corrected	Precipitation accumulated	60071	3171	15558	24862	13522	439	57113	1618	794
		Mean	2002	106	519	829	451	15	1904	54	26
		Standard Deviation	687	141	216	434	231	30	658	65	33
		CV (%)	34	133	42	52	51	202	35	120	126
		Percentage to annual	100	5	26	41	23	1	95	3	1
CERF_ACS_CNRM_CM5	Raw Data	Precipitation accumulated	21830	2135	7702	7299	3149	77	20285	1265	98

		Mean	728	71	257	243	105	3	676	42	3
		Standard Deviation	161	49	78	91	79	4	156	49	6
		CV (%)	22	68	30	37	75	145	23	116	191
		Percentage to annual	100	10	35	33	14	0	93	6	0
	DBS Corrected	Precipitation accumulated	58535	5945	21891	20136	8001	482	55973	1885	119
		Mean	1951	198	730	671	267	16	1866	63	4
		Standard Deviation	450	149	227	270	207	37	438	100	9
		CV (%)	23	75	31	40	77	232	24	159	238
		Percentage to annual	100	10	37	34	14	1	96	3	0
MPI_ESM_LR	Raw Data	Precipitation accumulated	14291	1782	4080	3116	3502	103	12480	1437	202
		Mean	476	59	136	104	117	3	416	48	7
		Standard Deviation	116	45	61	53	80	17	118	45	16
		CV (%)	24	76	45	51	69	488	28	95	234
		Percentage to annual	100	12	29	22	25	1	87	10	1
	DBS Corrected	Precipitation accumulated	66279	9241	20392	16774	17506	376	63913	1684	230
		Mean	2209	308	680	559	584	13	2130	56	8
		Standard Deviation	491	196	239	212	329	36	497	54	21
		CV (%)	22	63	35	38	56	288	23	97	267
		Percentage to annual	100	14	31	25	26	1	96	3	0
HadGE M2_ES	Raw Data	Precipitation accumulated	4490	85	1191	1707	418	93	3401	701	203
		Mean	150	3	40	57	14	3	113	23	7
		Standard Deviation	69	5	34	53	24	6	60	24	11
		CV (%)	46	185	86	92	172	200	53	104	166
		Percentage to annual	100	2	27	38	9	2	76	16	5

	DBS Corr ected	Precipitation accumulated	61670	4892	2205 1	24714	7360	459	59017	1792	321
		Mean	2056	163	735	824	245	15	1967	60	11
		Standard Deviation	606	89	320	402	254	34	598	67	19
		CV (%)	29	55	44	49	103	225	30	113	174
		Percentage to annual	100	8	36	40	12	1	96	3	1

Appendix 2

Month/ Season		Relative change to baseline	Annual	June	July	August	September	Pre- Monsoon	Southwest Monsoon	Post Monsoon	Winter
BCC_C SM1.1	2010- 40	Precipitation accumulated	22	-6908	-13115	1109	8773	153	-10141	10301	61942
		Mean	1	-230	-437	37	292	5	-338	343	2065
		Standard Deviation	-459	-140	-108	97	37	-4	58	220	680
		CV (%)	-23	266	20	12	-39	-81	9	-26	-101
		Percentage to annual	0	-11	-22	2	14	0	-17	17	102
	2040- 70	Precipitation accumulated	9430	3602	2473	1240	2267	153	9582	-307	-83
		Mean	314	120	82	41	76	5	319	-10	-3
		Standard Deviation	185	143	-6	101	-39	-4	177	-4	-15
		CV (%)	5	15	-5	13	-30	-81	5	14	-45
		Percentage to annual	0	4	-1	-3	1	0	1	-1	0
	2070- 99	Precipitation accumulated	10730	1956	3007	2738	1931	153	9632	170	104
		Mean	358	65	100	91	64	5	321	6	3
		Standard Deviation	141	40	-7	112	20	-4	160	23	3

		CV (%)	2	-3	-5	11	-11	-81	4	33	-6	
		Percent age to annual										
			0	1	-1	-1	1	0	-1	0	0	
CanES M1.1	2010-40	Precipitation accumulated										
			3742	1815	-199	1524	3903	116	3413	462	180	
		Mean	125	-61	-7	51	130	4	114	15	6	
		Standard Deviation	-142	-83	-2	-40	-67	1	-142	4	36	
		CV (%)	-9	3	1	-9	-16	-35	-10	-21	79	
			Percent age to annual	0	-3	-2	0	4	0	0	1	0
	2040-70	Precipitation accumulated										
			-	-	-							
			5724	-949	1754	-3188	-655	116	-6546	1661	-508	
		Mean	-191	-32	-58	-106	-22	4	-218	55	-17	
		Standard Deviation	-20	-25	-52	25	1	1	-37	43	-30	
		CV (%)	3	21	-1	14	2	-35	3	-21	-49	
			Percent age to annual	0	-1	-1	-2	2	0	-2	4	-1
2070-99	Precipitation accumulated											
		-	-	-								
		8366	1294	3255	-6234	291	116	-10492	2308	119		
	Mean	-279	-43	-109	-208	10	4	-350	77	4		
	Standard Deviation	-191	-29	-84	-74	-5	1	-176	20	18		
		CV (%)	-5	39	2	5	-1	-35	-3	-55	39	
		Percent age to annual	0	-2	-3	-7	6	0	-5	5	0	

INM_C M4	2010- 40	Precipitation accumulated	6284	-609	3116	401	2336	104	5244	-300	785
		Mean	209	-20	104	13	78	3	175	-10	26
		Standard Deviation	73	-55	23	-86	46	-16	59	-19	21
		CV (%)	1	-62	-9	-10	2	-125	0	-11	-9
		Percent age to annual	0	-1	2	-3	1	0	-1	-1	1
	2040- 70	Precipitation accumulated	4728	-933	197	4527	2028	104	5819	-885	44
		Mean	158	-31	7	151	68	3	194	-30	1
		Standard Deviation	431	-67	19	200	36	-16	396	-40	35
		CV (%)	16	-71	3	12	1	-125	15	4	71
		Percent age to annual	0	-2	-1	4	1	0	2	-1	0
	2070- 99	Precipitation accumulated	18236	-766	5517	6495	5492	104	16738	526	464
		Mean	608	-26	184	217	183	3	558	18	15
		Standard Deviation	326	-57	138	79	130	-16	352	15	53
		CV (%)	5	-54	0	-2	6	-125	7	-11	60
		Percent age to annual	0	-2	1	-2	1	0	0	0	0
IPSL_ CM5A _MR	2010- 40	Precipitation accumulated	-558	-451	656	-126	-1225	235	-1146	973	-528

		Mean	-19	-15	22	-4	-41	8	-38	32	-18
		Standard Deviation	-98	-8	28	-69	-1	7	-61	35	-4
		CV (%)	-4	7	4	-7	2	-47	-2	-11	54
		Percentage to annual	0	-1	1	0	-1	0	-1	1	-1
	2040-70	Precipitation accumulated	18181	-558	2136	8997	4785	235	15360	1684	241
		Mean	606	-19	71	300	160	8	512	56	8
		Standard Deviation	185	-9	76	173	21	7	175	29	25
		CV (%)	0	8	7	2	-3	-47	1	-46	29
		Percentage to annual	0	-1	-1	1	-1	0	-2	1	0
	2070-99	Precipitation accumulated	1798	168	834	-4090	3593	235	505	1066	-85
		Mean	60	6	28	-136	120	8	17	36	-3
		Standard Deviation	-96	17	124	-93	-13	7	-94	19	13
		CV (%)	-5	11	27	-3	-6	-47	-4	-36	38
		Percentage to annual	0	0	1	-7	4	0	-2	1	0
NCAR_CCS_M4	2010-40	Precipitation accumulated	5960	-419	2216	2301	1896	114	5994	127	-43
		Mean	199	-14	74	77	63	4	200	4	-1
		Standard Deviation	-22	-76	-8	-1	-7	-11	-19	6	-9

		CV (%)	-3	-29	-5	-5	-10	-103	-3	3	-30
		Percent age to annual									
			0	-2	0	1	1	0	1	0	0
	2040-70	Precipitation accumulated	1285								
			2	-167	5423	3206	3307	114	11769	761	122
		Mean	428	-6	181	107	110	4	392	25	4
		Standard Deviation									
			134	33	196	39	59	-11	181	56	22
		CV (%)									
			2	17	15	-1	0	-103	4	35	56
		Percent age to annual									
			0	-2	2	-1	1	0	-1	0	0
	2070-99	Precipitation accumulated	1224								
			2	-302	6642	3109	3587	114	13036	-540	47
		Mean	408	-10	221	104	120	4	435	-18	2
		Standard Deviation									
			21	-35	31	-26	46	-11	44	-21	13
		CV (%)									
			-3	-12	-7	-10	-4	-103	-3	-6	37
		Percent age to annual									
			0	-2	4	-1	2	0	2	-1	0
NorES M1_M	2010-40	Precipitation accumulated									
			418	705	1150	-1847	591	175	599	-41	78
		Mean	14	24	38	-62	20	6	20	-1	3
		Standard Deviation									
			-101	14	33	-108	-12	5	-70	-2	4
		CV (%)									
			-5	-13	3	-10	-5	-35	-4	-1	1
		Percent age to annual									
			0	1	2	-3	1	0	0	0	0

	2040-70	Precipitation accumulated	4674	451	3818	-3007	1382	175	2644	746	424
		Mean	156	15	127	-100	46	6	88	25	14
		Standard Deviation	-27	-23	28	-135	42	5	-90	37	44
		CV (%)	-4	-35	-4	-11	4	-35	-6	9	65
		Percentage to annual	0	0	4	-8	1	0	-3	1	1
	2070-99	Precipitation accumulated	18221	1234	6963	2312	3469	175	13978	1881	179
		Mean	607	41	232	77	116	6	466	63	6
		Standard Deviation	-204	27	36	-114	95	5	-203	39	8
		CV (%)	-16	-19	-8	-17	6	-35	-15	-31	0
		Percentage to annual	0	0	3	-7	-1	0	-4	2	0
CERF ACS_C NRM_ CM5	2010-40	Precipitation accumulated	3704	1366	1348	2059	-418	132	1659	247	375
		Mean	123	46	-45	69	-14	4	55	8	13
		Standard Deviation	1	20	-45	-9	-40	-3	-3	-11	26
		CV (%)	-1	-6	-5	-5	-12	-65	-1	-33	-24
		Percentage to annual	0	2	-4	1	-1	0	-3	0	1
	2040-70	Precipitation accumulated	5541	2793	1068	-1872	1140	132	3129	897	433

		Mean	185	93	36	-62	38	4	104	30	14
		Standard Deviation	-132	41	25	-43	22	-3	-117	-1	26
		CV (%)	-8	-10	2	-3	-2	-65	-7	-52	-48
		Percentage to annual	0	3	-2	-6	1	0	-3	1	1
	2070-99	Precipitation accumulated	8398	5332	3087	-1277	368	132	7510	414	474
		Mean	280	178	103	-43	12	4	250	14	16
		Standard Deviation	30	91	-32	51	-43	-3	44	-38	28
		CV (%)	-2	-11	-8	11	-19	-65	-1	-78	-46
		Percentage to annual	0	7	0	-6	-1	0	-1	0	1
MPI_ESM_LR	2010-40	Precipitation accumulated	1026	-153	1239	2100	-367	238	341	811	24
		Mean	34	-5	-41	70	-12	8	11	27	1
		Standard Deviation	15	3	35	41	-4	-2	-10	25	-8
		CV (%)	0	2	8	2	1	-121	-1	-1	-119
		Percentage to annual	0	0	-2	3	-1	0	-1	1	0
	2040-70	Precipitation accumulated	6118	-869	5234	-670	1067	238	-5706	-18	-146
		Mean	-204	-29	-174	-22	36	8	-190	-1	-5
		Standard Deviation	216	43	-20	127	33	-2	207	-8	-14

		CV (%)	13	22	8	25	2	-121	13	-13	-26
		Percent age to annual									
			0	0	-6	1	4	0	0	0	0
	2070-99	Precipitation accumulated									
			8461	1748	3884	-1059	-1174	238	-7865	-564	120
		Mean	-282	-58	-129	-35	-39	8	-262	-19	4
		Standard Deviation									
			121	20	75	85	-74	-2	113	-12	6
		CV (%)	10	23	22	19	-9	-121	9	16	-40
		Percent age to annual									
			0	-1	-2	2	2	0	1	-1	0
HadGE M2_ES	2010-40	Precipitation accumulated									
			14742	-451	8800	963	6055	155	15367	-563	-69
		Mean	491	-15	293	32	202	5	512	-19	-2
		Standard Deviation									
			167	7	113	-85	104	0	144	1	3
		CV (%)	1	10	-1	-12	-23	-58	0	55	78
		Percent age to annual									
			0	-2	5	-6	6	0	2	-1	0
	2040-70	Precipitation accumulated									
			14916	-1508	7365	6555	2961	155	15373	-373	-6
		Mean	497	-50	246	219	99	5	512	-12	0
		Standard Deviation									
			119	-4	138	25	39	0	115	25	2
		CV (%)	-1	21	3	-8	-18	-58	-2	82	18
		Percent age to annual									
			0	-3	3	1	2	0	1	-1	0

	2070-99	Precipitation accumulated	22525	298	7181	9901	5786	155	23166	-844	21
	Mean		751	10	239	330	193	5	772	-28	1
	Standard Deviation		45	92	55	-9	91	0	69	-25	2
	CV (%)		-6	50	-5	-15	-25	-58	-6	20	5
	Percentage to annual		0	-2	-1	1	4	0	2	-2	0

Appended paper

V

Rana, A., Madan, S. and Bengtsson, L. (2012) Performance Evaluation of Regional Climate Models (RCMs) in determining precipitation characteristics for Göteborg, Sweden. Hydrology Research. doi:10.2166/nh.2013.160

Performance evaluation of regional climate models (RCMs) in determining precipitation characteristics for Gothenburg, Sweden

Arun Rana, Shilpy Madan and Lars Bengtsson

ABSTRACT

Regional climate models (RCMs) are used for forecasting future climate including precipitation characteristics. Analysis of such models for prediction of climate on the local scale in the performance of five different RCMs for predicting the precipitation characteristics for Gothenburg, Sweden over the period 1961 to 2009 was investigated using daily observed rain series for comparison. Statistical analysis was done on annual, monthly, multi-daily, and daily data. The statistical techniques used include principal component analysis (PCA), comparison of annual maximum, frequency of exceedances determined from Poisson distribution, comparison of frequency distributions, and Mann–Kendall technique for investigating trend over time. Inter-annual variability and autocorrelation between years were also investigated. The results obtained point towards the usefulness of these high-resolution RCMs. It was observed that all the models give the annual maximum precipitation within 3 mm of the observed data. As for the observation series, no trends were found for monthly or seasonal data. The number of exceedances above threshold accepted Poisson distribution hypothesis with the statistics from PROMES being very close to the statistics from the observations. PCA also indicated that PROMES came closest to the observations. The presented statistical methods can be used for bias correction of raw RCM data in future studies.

Key words | climate change, daily precipitation, extreme precipitation, Gothenburg, regional climate models (RCMs), statistical techniques

Arun Rana (corresponding author)

Lars Bengtsson

Department of Water Resources Engineering, LTH,
Lund University,
Box No. 118,
Lund 22100,
Sweden

E-mail: Arun.Rana@tvrl.lth.se;
arunranain@gmail.com

Shilpy Madan

Department of Mathematical Statistics,
Lund University,
Box No. 118,
Lund 22100,
Sweden

INTRODUCTION

Climate change is expected to lead to changed precipitation patterns in many regions. Dore (2005) highlighted broad implications for future global precipitation suggesting that several regional precipitation trends can already be detected and are likely to increase in the future. In western Europe, mainly the daily winter precipitation has changed leading to increased annual precipitation shown for Sweden by Busuioc *et al.* (2011). For Britain, with a similar climate to western Sweden, Maraun *et al.* (2008) showed that the winter rains have become more intense but that the daily summer storms rather have decreased in intensity or show inter-decadal variability. Using 600 gauges within the Rhine basin, Hundecha & Bárdossy (2005) concluded that

the large daily precipitation showed an increasing trend over 50 years in all seasons except summer, where it showed the opposite trend.

For predicting future climate trends, high resolution climate models must be used. Some of the earliest studies of the potential impacts of global warming in Europe were based on idealized global climate model (GCM) simulations. Some studies used results from only one model to illustrate potential impacts (e.g., Emanuel *et al.* 1985) and some used a range of models for impact studies to ensure consistency (e.g., Parry 1989). Later studies recognized inter-model uncertainties and adopted outputs from several GCMs (e.g., Rotmans *et al.* 1994). The precipitation characteristics

vary so much from region to region and locally within regions so the precipitation pattern can only be caught when the scale in the climate models is reduced. Jones *et al.* (1997), among others, have pointed out the advantages of using regional climate model (RCM) data over GCM data for small-scale spatial studies. RCMs represent an advantage over GCM data for representing small-scale processes as pointed out by Durman *et al.* (2001). RCM simulations are more realistic, when scaled, in comparison to GCM simulation data. Gao *et al.* (2008) have also reached the same conclusion that RCM outperforms the driving GCMs in predicting future climate scenarios in terms of both spatial pattern and amount of precipitation.

Jones & Reid (2001) studied the plausible increase in heaviest precipitation over Britain using RCM integrations. Although any significant increase of extreme daily storms have not yet been observed in western Europe, these model simulations indicated that daily storms are expected to increase significantly in the future, as was also found for northwestern Europe by Raisanen & Joellsson (2001). Climate projections for Sweden indicate higher temperatures, especially during winter. The Commission on Climate and Vulnerability was appointed by the Swedish Government in June 2005 to assess regional and local impacts of global climate change on Swedish society. In the study it was concluded that 'Sweden will become warmer and wetter'. Precipitation is likely to increase in most parts of the country during the autumn, winter, and spring time. In summer-time the climate will be warmer and drier, particularly in southern Sweden. Large storms are said to be expected to increase in future.

A comparison is sought, to see the extent of the local climatic/precipitation pattern that can be forecasted by RCMs as the model output ought to be compared with historic data. Jacob *et al.* (2007) did an inter-comparison of regional climate models' performance comparing with the present day climate. Jeong *et al.* (2011) studied the diurnal cycle of precipitation in Sweden and compared model output with observations. The intention with the present study is to do a similar test on how well different RCMs perform in determining precipitation characteristics on a local scale. The objective of the study includes: (1) analysis of raw RCMs output to represent local-scale precipitation processes; (2) comparative analysis using statistical methods of raw RCM

output data with that of observations recorded; and finally, (3) analyze bias correction that can be implemented in RCM output for better representation of local phenomena in the future. Since the objective of the paper included study of RCM predictions in predicting climate/precipitation over a small spatial scale, comparison was made in terms of observed historic data and RCM output itself without bias correction. With that intention, performance of raw RCMs outputs and usefulness of different statistical methods for bias correction, only five RCMs were chosen for the present study. The five different RCMs were used for forecasting daily precipitation in Gothenburg, on Sweden's west coast. Their performance was analyzed for data period 1961–2009 by comparing with observed data for the same period. Annual, monthly, daily, and multi-daily precipitation events were considered for the statistical analysis. Statistical significance of various tests are checked to conclude if any model exists whose simulations can be relied upon for predicting future rain characteristics without bias correction. If not the case, the presented statistical methods can be further used for bias correction method for future impact studies. Similar studies for southern Sweden have been carried out by Achberger *et al.* (2003) where the authors have compared observations with output from RCMs.

DATA BASE

Observed precipitation

Gothenburg (Swedish: Göteborg) is the second largest city in Sweden. It is inhabited by approximately 500,000 people. It is situated on the west coast of Sweden at the mouth of the river Göta Älv, as shown in Figure 1; Gothenburg lies at 57°42'N, 11°55'E on the longitude–latitude grid. The annual mean precipitation is about 800 mm, 37% of days are wet days. The mean annual daily precipitation is 35 mm. The observed data are from the Säve gauge station which is about 15 km east of the central part of Gothenburg. The precipitation is rather uniformly distributed over the year with 200 mm in June–August and also 200 mm for the winter months of December–February. It is 250 mm in September–November and 150 mm in March–May. Most of the large daily rainfalls are a consequence of cyclonic

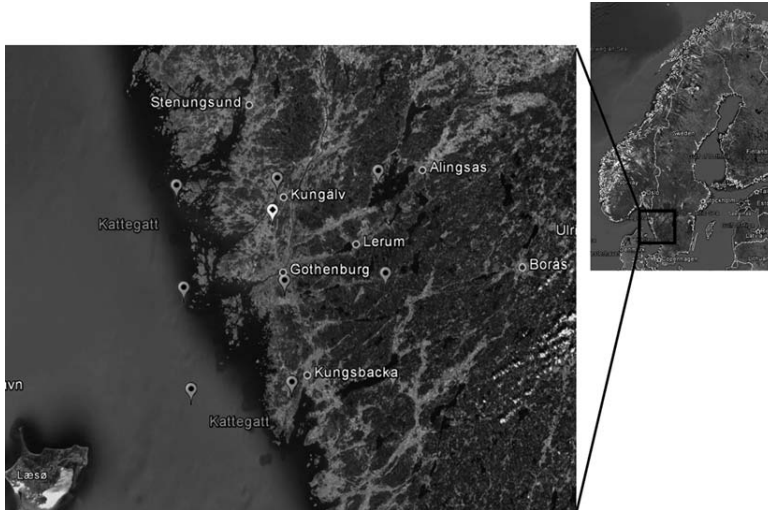

Figure 1 | Study area, Gothenburg, depicting the observation station and the grid points used in the study.

weather conditions (Hellstrom 2005). Large daily events are most common in July and August but the largest daily rain was observed in December 1976. There are missing data in the stipulated period of year 2004–2005.

RCM data

The RCM data is a grid of 25×25 km resolution, shown in Figure 1. The grid size and dimensions was the same for all five RCMs. The five RCMs were derived from the two GCMs, HadCM3Q0 and ECHAM5-r3. An ensemble of 19 regional climate integrations with a resolution of 25 km has become available through the ENSEMBLES project

coordinated by the MET Office Hadley Centre. These integrations are based on the A1B emission scenario and run up to year 2100, with the area of focus being Europe. The simulated data were obtained from the data archive of the Danish Meteorological Institute (DMI) and can be accessed via <http://ensemblesr3.dmi.dk/>. The statistical analysis was then performed on these daily data, either as daily values or derived monthly or annual values.

The models used in this study are given in Table 1. The RCMs chosen for the study are based on the criteria that they have same grid size of 25 km resolution and also the same grid coordinates around Gothenburg, as depicted in Figure 1. RCM CLM, the climate version of the Lokal Q2

Table 1 | The members of the multi-model ensemble used in the study with grid resolution of 25 km

Model	Scenario	Global model	Regional model	Institute	Period
M1	A1	HadCM3Q0	CLM	ETHZ, Switzerland	150
M2	A1	HadCM3Q0	PROMES	UCLM, Spain	100
M3	A1	HadCM3Q0	HadRM3Q0	HC, United Kingdom	150
M4	A1	ECHAM5-r3	RACMO2	KNMI, Netherlands	150
M5	A1	ECHAM5-r3	REMO	MPI, Germany	150

Model (LM), is a non-hydrostatic regional climate model. It was developed by the Swiss Institute of Technology. RCM REMO is based on the Europa model from the German Weather Service and is used by the Max Planck Institute for Meteorology. It uses a slightly modified physical parameterization scheme and has been tested in different climates (Frei *et al.* 2005). RCM PROMES is used by Universidad de Castilla La Mancha, Spain. It is a state of the art primitive equation model, hydrostatic and fully compressible. RCM RACMO2 is used by the Royal Netherlands Meteorological Institute, the Netherlands. It combines the land surface characteristics and the dynamical core of HIRLAM numerical weather prediction system with the physical parameterization scheme of the European Centre for Medium Range Weather Forecasting (ECMWF). RCM HadRM3Q0 is used by the Hadley Centre. The physical parameters incorporated in the model include calculation of large-scale cloud and also include assumptions about the radiative effects from convective clouds.

For comparison with observed precipitation in Gothenburg, three sets of data are used. The first set incorporates the daily precipitation data from 1 January 1961 to 31 December 2009. The second set is derived from daily observations and incorporates the monthly mean precipitation. Lastly, the third set accounts for annual mean precipitation values for the data period, i.e., 1961 to 2009.

STATISTICAL METHODOLOGY

The RCMs simulate precipitation with daily steps. In the statistical analysis as for the observed daily rain series precipitation less than 1 mm is considered to be a 'no event'. Comparison between simulations and observations is done on mean statistics, not between individual days or years. Statistical techniques are used to analyze how well RCMs track the observed precipitation and can be relied upon for future predictions of precipitation and bias correction.

Descriptive statistics and rainfall distribution (CDF)

The daily rainfall frequency distributions of the observed data and the model simulations are determined and compared with focus on rare events, but also the number of wet days

was considered. Descriptive statistics were calculated for observations and predicted data sets including mean, median, and standard deviation. This was then followed by calculation of coefficient of variation (CV) in monthly precipitation over a year and averaging over all years and seasonal events (winter and summer) to analyze variability in the annual and seasonal patterns. The fit to different theoretical distributions was investigated. Cumulative distribution $F(x)$ can be defined as the proportion of observations lying below a certain value x . The cumulative distribution for all models simulation runs is compared with observed data.

Extreme event analysis

Extremes events of precipitation were studied by determining annual daily maximum, 2-day, 3-day, and 7-day annual maximum. Annual maxima are considered for fitting generalized extreme value (GEV) distribution and determining return periods. The type of extreme events considered here are the maximum of a sequence type, i.e., use annual maxima of daily precipitation amounts. The choice of block size is critical as too small a block size can lead to bias and blocks that are too large generate inadequate block maxima while performing the fit. This may lead to large estimation variance. The block maxima approach is closely associated with the use of the GEV family. All parameters are estimated by the method of maximum likelihood estimation. The GEV distribution functions have the form:

$$G(y) = \exp\left(-\left(1 + \gamma \frac{y - \mu}{\sigma}\right)_+^{-\frac{1}{\gamma}}\right)$$

where σ , μ , and γ are the scale, location, and shape parameters, respectively.

Poisson distribution is used to model the number of occurrences of extreme events (here daily precipitation exceeding a threshold value) within a given year. It can be used for data that involve random sums of rare events. We consider the extreme event exceedance of a threshold value. The cumulative function is:

$$F(k) = \frac{\tau(k+1, \lambda)}{k!}$$

where k is number of exceedances in a year, λ is the poisson parameter, and τ is the incomplete gamma function. An event was considered extreme if the daily precipitation exceeded 20 mm. An extreme event was defined as the event exceeding 99th percentile of the data. Number of rainy days (frequency) during summer and winter season was also calculated to analyze rain frequency during different seasons.

Inter-annual variability and autocorrelation

From investigations of twentieth century precipitation in Germany, Trömel & Schönwiese (2007) found that the variation of annual precipitation between years has increased. Therefore, the variation between years was also investigated in the present study for annual, summer, and winter months. The inter-annual variability was determined by computing the relative change percentage (RC) of the sampled data. The inter-annual RC for the model outputs are compared with that of the observed annual precipitation. Large changes indicate that there is no correlation of precipitation between different years. The correlation between years can be checked, although not in a very straightforward manner, by computing the mean CV to determine a CV index. These two techniques have been used previously in studying climate change scenarios, for example by Giorgi *et al.* (2004) and Attema & Lenderink (2011). The annual relative change for observed and simulation is calculated as:

$$RC = \frac{\text{value in succeeding year} - \text{value in current year}}{\text{value in current year}}$$

The main advantage of using this method is that it removes the dependency of standard deviation on mean precipitation. The trend, if any, must be filtered out. A more straightforward way of investigating the dependence of the precipitation of a certain year to the precipitation of the previous year, is to compute the autocorrelation. This was also done and the autocorrelation for the model simulations was compared with the computed observed correlation value. A -0.2 to 0.2 band was taken as the confidence band for insignificant autocorrelation measure when using a 10-year lag period.

Mann–Kendall test

Any presence of trend over the 50 years was analyzed using the Mann–Kendall trend procedure for monthly rainfall over the years considering winter and summer conditions separately. The Mann–Kendall test is a popular statistical method used by contemporary climatologists, Wibig & Glowicki (2002), Lu *et al.* (2004), and Gadgil & Dhorde (2005) among others, as a significant test for checking the overall trend. Using the Mann–Kendall no assumptions about distribution are necessary. Also, it is not much affected by outliers because its statistic is based on the sign of differences and not directly on the values of the random variable. The significance level that there is no trend was set to 5%. Since the RCMs predict changes of precipitation in the future, tests showing that trends or no trends are the same for the model outputs as for observations are important for the confidence of the models.

Principal component analysis (PCA)

PCA is a multivariate statistical analysis, which attempts to simplify a complex set of interrelationships by creating one or few variables, with respect to those that allow a more convenient examination of the overall spatial relationship. The overall variance in a data set is explained by isolating a number of components with respect to newly defined axes, each of which corresponds to a variable (e.g., Richman 1986). It helps to identify patterns in the data and express the data such that these similarities and differences are highlighted. PCA can be understood as a variable reduction procedure. PCA is used on monthly precipitation.

RESULTS

Descriptive statistics and rainfall distribution (CDF)

The cumulative distribution of monthly rainfall was computed for observed as well as for simulated precipitation and plotted in Figure 2. It is seen that all models generally fit a similar distribution as the observed one. PROMES captures the end tail of the observed distribution well, but the cumulative curve lies below the observed one. PROMES

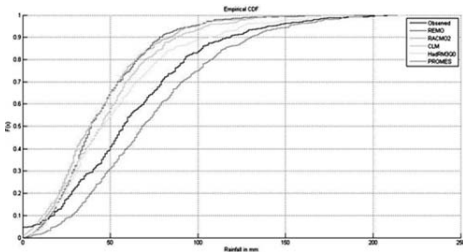

Q4 Figure 2 | The cumulative distribution function of monthly rainfall amounts from observations and various model simulations.

gives a wetter climate than the actual observed, while the other models give a rather much drier climate. Historic data are missing for year 2004–2005 which explains that $F(0) \approx 0.05$ for the observed CDF in the graph (Figure 2). The distribution parameters are shown and compared in Table 2. Similar observations can be made from the table that PROMES is predicting a wetter climate as compared to other models in the stipulated time period in terms of mean, median, and standard deviation. The first and second order moments of PROMES simulated data come closest to the moments of the observed set of data. The variability in recorded data is well captured by this model simulation while there exists a minor positive bias in mean value of the distribution. Other models' simulations give a negative bias in estimating the mean value of rainfall distribution and the spread of data is also not appropriately defined. The coefficients of variation for observed and

simulated data are presented in Table 3 for annual, winter, and summer months. CV is less than 1 for all data sets, implying that there is no significant inter-annual variation in precipitation in Gothenburg. REMO (0.57) and PROMES (0.53) gave slightly smaller index values of CV in comparison to the observed (0.63). It has been found in other studies that wet RCMs usually underestimate the CV (Giorgi et al. 2004).

Extreme event analysis

Daily storms were analyzed for extreme events. It was found that all data sets fitted well to the GEV family. Apart from RACMO2, all datasets accepted the Gumbel distribution. The parameter estimates and plots are shown in Table 4 and Figure 3. It can be seen that CLM and PROMES data gave similar parameter estimates as the observed series. The return level plot of CLM and PROMES came closest to the ones generated by the observed data set. The annual daily maximum precipitation is shown against the return period. The 10-year daily storm is about 40 mm, which also was predicted from the PROMES and CLM simulations. It was observed that all the models give annual maximum precipitation within 3 mm of the observed values.

Poisson distribution was used to determine the frequency of extreme events occurring several times in a year. Daily rains exceeding 20 mm were analyzed. The fit of the different model simulations to the Poisson distribution

Table 2 | Distribution parameter estimates for monthly precipitation

	Observed	REMO	RACMO2	CLM	HadRM3Q0	PROMES
Mean	63.33	45.12	44.32	47.98	53.76	74.60
Median	57	39	38.50	45	45	68
Standard deviation	40.51	27.23	28.30	30.61	36.46	40.38

Table 3 | CV of variation of annual, summer, and winter precipitation for each model

CV	Observed	REMO	RACMO2	CLM	HadRM3Q0	PROMES
Annual	0.63	0.57	0.61	0.62	0.66	0.53
Summer	0.47	0.47	0.59	0.78	0.71	0.48
Winter	0.52	0.48	0.54	0.39	0.43	0.45

Table 4 | Maximum likelihood estimates of GEV parameters

	Observed	REMO	RACMO2	CLM	HadRM3Q0	PROMES
Mu (μ)	27.98	25.55	28.50	29.14	30.42	28.60
Sigma (σ)	12.19	8.79	6.46	8.82	8.21	6.09
Gamma (γ)	-0.07	0.29	0.09	-0.01	-0.16	-0.19
Gumbel hypothesis	Accept	Accept	Reject	Accept	Accept	Accept

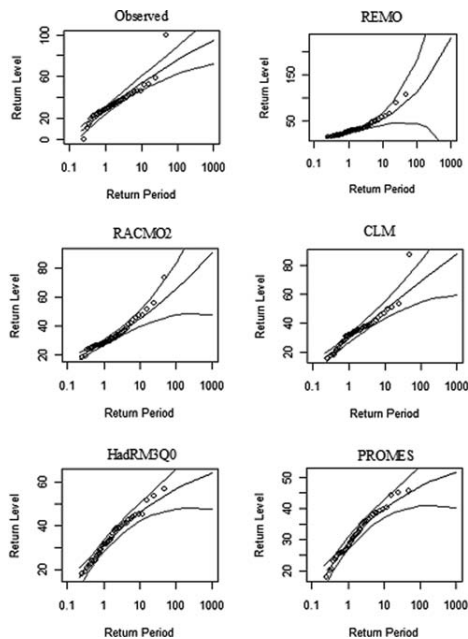
**Q5 Figure 3** | GEV for fitted observed and climate model data with return level (intensity of precipitation in mm) and return period (years).**Table 5** | Poisson distribution fit to data set

	Lambda	P value	Poisson hypothesis
Observed	4.65	0.09	Accept
REMO	2.18	0.06	Accept
RACMO2	2.79	0.53	Accept
CLM	3.02	0.52	Accept
HadRM3Q0	3.79	0.02	Reject
PROMES	4.24	0.65	Accept

is reported in Table 5. All models accept the Poisson distribution hypothesis for the frequency of exceedances except HadRM3Q0. The parameter value for the Poisson distribution determined using PROMES data is almost the same as for the observed data indicating four to five occurrences of extreme rainfall in a year. The other models underestimate the frequency of such occurrences and predict two to three events in a year. Monthly average precipitation over years indicated that all models gave fairly close values of these averages as were seen in the recorded data. The output generated from model simulations are given in Table 6.

The mean values of the annual maxima of 1 day, 2 day, 3 day, and 7 day were computed. All models showed values close to the observed values for 1–3 day annual maximum precipitation, while for HadRM3Q0 and PROMES the 7 day annual maximum precipitation was computed too low (Table 6). The number of rainfall events in summer and winter months is presented in Table 7. It can be observed from the table that REMO and PROMES overestimate the number of rainy days for summer season as compared to observed data whereas all others underestimate the same. In winter season all the models overestimate the number of rainy days in the area.

Inter-annual variability and autocorrelation

The annual precipitation at a location may be quite stable from year to year, vary rather a lot or be correlated to the precipitation in the previous year. The annual relative change is a measure of the inter-annual variability. It was determined for the simulated data from each model and for historic annual data series. Figure 4 shows the computed relative change for all the series. Figure 4(a) shows the variability during summer season, Figure 4(b) depicts variability during winter and Figure 4(c) depicts the same in annual

Table 6 | Annual mean maximum for daily and multi-daily precipitation

(Average)	Observed	REMO	RACMO2	CLM	HadRM3Q0	PROMES
Day max.	33.73	34.00	32.90	34.00	34.02	31.15
2-day max.	42.60	43.23	43.48	44.11	47.60	42.42
3-day max.	50.22	48.85	50.04	49.79	55.07	51.22
7-day max.	74.17	62.00	64.95	65.92	76.56	78.05

Table 7 | Number of rainy days in summer and winter months as predicted by the RCM data and observed data for the entire period

Season	Observed	REMO	RACMO2	CLM	HadRM3Q0	PROMES
Summer						
Rainy	1,813	2,172	1,703	1,236	2,178	2,691
Non-rainy	2,695	2,336	2,805	3,174	2,231	1,719
Total days	4,508	4,508	4,508	4,410	4,409	4,410
Winter						
Rainy	2,168	2,852	2,667	2,764	2,291	2,957
Non-rainy	2,254	1,570	1,755	1,646	2,119	1,453
Total days	4,422	4,422	4,422	4,410	4,410	4,410

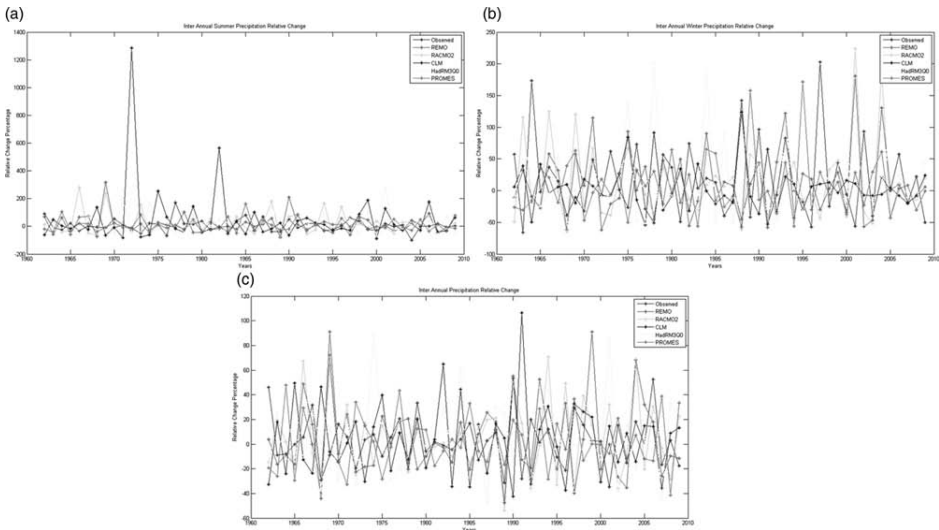

Figure 4 | Inter-annual relative change of precipitation as percentage during summer, winter, and annual time periods, respectively.

time series. A visual interpretation suggests that the observed pattern of change in annual precipitation is captured well by PROMES, while much less so by the other models. The average relative change in precipitation in Gothenburg from 1961 to 2009 has been 2.8%. PROMES gives an average relative change over these years of 2.3% followed by CLM with 3.6%. The variability can be associated with large-scale forcing which derives the local climatic conditions. Various studies have previously been performed to look at the effect of atmospheric circulations on precipitation in Sweden; notable among them is the study by Busuioc et al. (2011).

Autocorrelation was also performed on the observed and model data and the results are presented in Figure 5. It shows the autocorrelation for observed and model generated data for different lag periods in years. It can be inferred that for a lag of one year there is significant autocorrelation in annual precipitation in the observed data, which is duly

captured by REMO, but not by the other models. However, except for PROMES, all the models showed significant autocorrelation. For a larger time lag, ten years, there was insignificant autocorrelation in annual precipitation in the observed data set after a lag of one year.

Mann-Kendall test

Results of transient regional climate model integrations are compared with the monthly precipitation observational data sets from January 1961 to December 2009. They are tabulated in Table 8. There is no significant trend in the recorded data. The null hypothesis is accepted at 5% level of significance. In accordance with the observed data set none of the model simulations show the presence of any significant trend, nor for the winter precipitation do the models show any trend except PROMES. The *p* value, *Z* value and *S* counts of RCM-PROMES come closest to those of the

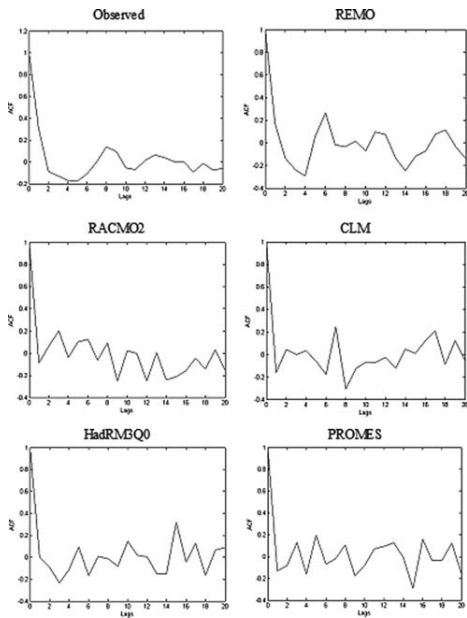

Q7 Figure 5 | Autocorrelation for observed and climate model data with time lag in years.

Table 8 | Mann-Kendall trend analysis of monthly precipitation for annual, summer, and winter seasons

Data	Trend	P value	Z value	S value
Monthly				
Observed	Absent	0.3178	0.999	4,755
REMO	Absent	0.9481	0.0651	311
RACMO2	Absent	0.418	0.8099	3,855
HadRM3Q0	Absent	0.6869	0.403	1,919
CLM	Absent	0.7445	0.3259	1,552
PROMES	Absent	0.4122	0.82	3,903
Summer				
Observed	Absent	0.8454	-0.195	-251
REMO	Absent	0.9645	-0.0445	-58
RACMO2	Absent	0.591	0.5374	690
HadRM3Q0	Absent	0.696	-0.3907	-502
CLM	Absent	0.416	-0.8135	-1,044
PROMES	Absent	0.4994	0.6754	867
Winter				
Observed	Absent	0.1193	1.5575	1,998
REMO	Absent	0.6691	0.4274	549
RACMO2	Absent	0.4447	0.7643	981
HadRM3Q0	Absent	0.2522	1.1449	1,469
CLM	Absent	0.3461	0.9422	1,209
PROMES	Present	0.0372	2.0832	2,672

Table 9 | Coefficients of principle components as explained by PCA from observed and simulated RCMs

Component/Model	Observed	REMO	RACMO2	CLM	HadRM3Q0	PROMES
Component 1	-0.18	0.36	0.38	0.45	0.54	-0.44
Component 2	-0.05	0.61	0.57	-0.41	-0.31	0.20
Component 3	0.82	0.10	0.14	0.33	0.16	0.40
Component 4	-0.53	-0.03	0.04	0.33	0.16	0.76
Component 5	0.04	0.43	-0.51	-0.45	0.57	0.14
Component 6	0.04	-0.55	0.50	-0.46	0.48	0.08

observed. The observations show a positive trend during winter season if tested at 10% significance level. Other models simulations however exhibited an absence of any such trend. None of the model simulations depict the presence of any significant trend in summer precipitation, which is in line with the absence of a significant trend even in historic data sets.

Principal component analysis

Monthly observed and simulated precipitation is used for PCA analysis. In general, the number of components extracted is equal to the number of variables under consideration. Of these components, it must be decided which of them are worthy of being retained for further interpretation. Only the first few components will account for explaining meaningful variance. Selecting four components more than 80% of the variance is explained. The first two components explained 28% and 23% of the variance, respectively. All eigenvalues were positive. The coefficients of principal components were plotted and are tabulated in Table 9. When the two components are plotted for the observed data, both the components lie close to the origin meaning that their impact is minor. It is important that the chosen principal components impact the observed data series. The first three principal components together explain approximately 70% variability in the data. Figure 6 depicts the plots for components, where Figure 6(a) represents the plot of component 1 with component 2 and Figure 6(b) represents component 1 with component 3. This plot of PCA suggests that observations are mostly influenced by component 3. The PROMES result lies in the same grid as the observed result while the output from the other models

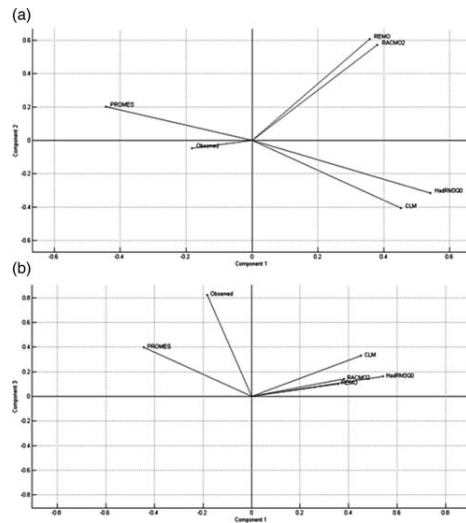

Figure 6 | PCA using component 1, component 2, and component 3: (a) represents plots of component 1 with that of component 2 and (b) represents component 1 with component 3. **Q8**

lies in different grids. It is seen that PROMES and 'observed' lie in the same quadrant. This suggests that PROMES come closest to explaining the variability of the observations. Simulations generated by RCM-PROMES are of a similar nature as observed monthly precipitation.

DISCUSSION AND CONCLUSION

Given the potential implications of regional climate changes towards documenting national policies and

building infrastructure that meets climate-related extreme events such as droughts, floods, and hurricanes, one needs to study how reliable are projections given by RCMs of future change. A way of testing models is to compute their performance over time and, as was done in this study, along with feasibility of the statistical methods to be used for bias correction. PCA analysis on monthly precipitation data sets revealed that RCM-PROMES simulations lie in the same phase as the observed series, whereas all other model simulations were found to lie in different phases. It was observed from CDF curves that the tail end of the observed distribution of monthly precipitation was captured by PROMES. The Mann-Kendall test showed no significant trend in monthly precipitation over the years either in historic data or in model simulations. All models except RACMO2 accepted the Gumbel distribution hypothesis. The observed data, RCM-PROMES, and CLM give similar parameter estimates of location, scale, and shape parameters of the GEV distribution and all estimated a return level of 40 mm in every ten years. Also, the frequency of moderately large events as determined from the models accepted the Poisson distribution hypothesis except for RCM-HadRM3Q0. PROMES, in accordance with the historic data, predicts four to five events exceeding 20 mm in a year. The annual variability is well described particularly by PROMES. Model simulations followed in accordance with the autocorrelation as observed in annual precipitation of historic data. REMO best depicted the historic data autocorrelation measure, followed by PROMES.

One can conclude that regional climate models are able to capture the characteristics of daily precipitation on a rather local scale, but there is a need to realize the bias correction methods used for impact studies. Presented statistical methods can be used for correcting raw RCM data in accordance with observed values and can then be thoroughly used for impact studies. Among the five regional climate models considered RCM-PROMES simulation statistics are able to best define the patterns and occurrence of events as seen in the recorded historic data. Results also indicate that there are conceptual problems and practical limitations in using these high-resolution climate model outputs for predicting ecosystem responses. However, the mean statistics are well described

in them which should be sufficient for most ecosystem problems.

REFERENCES

- Achberger, C., Linderson, M. L. & Chen, D. 2005 Performance of the Rossby Centre regional atmospheric model in Southern Sweden: comparison of simulated and observed precipitation. *Theor. Appl. Climatol.* **76** (3–4), 219–234.
- Busuioc, A., Chen, D. & Hellström, C. 2011 Temporal and spatial variability of precipitation in Sweden and its link with the large-scale atmospheric circulation. *Tellus A* **53**, 348–367.
- Dore, M. H. I. 2005 Climate change and changes in global precipitation patterns: what do we know? *Environ. Int.* **31** (8), 1167–1181.
- Durman, C. F., Gregory, J. M., Hassell, D. C., Jones, R. G. & Murphy, J. M. 2001 A comparison of extreme European daily precipitation simulated by a global and a regional climate model for present and future climates. *Q. J. R. Meteor. Soc.* **127** (573), 1005–1015.
- Emanuel, W. R., Shugart, H. H. & Stevenson, M. P. 1985 Climatic change and the broad-scale distribution of terrestrial ecosystem complexes. *Clim. Change* **7** (1), 29–43.
- Frei, C., Christensen, J. H., Deque, M., Jacob, D., Jones, R. G. & Vidale, P. L. 2005 Daily precipitation statistics in regional climate models: evaluation and intercomparison for the European Alps. *J. Geophys. Res.* **108** (D3), 4124, DOI: 4124 ISBN: 0747-7309.
- Gadgil, A. & Dhorde, A. 2005 Temperature trends in twentieth century at Pune, India. *Atmos. Environ.* **39** (35), 6550–6556.
- Gao, X., Shi, Y., Song, R., Giorgi, F., Wang, Y. & Zhang, D. 2008 Reduction of future monsoon precipitation over China: comparison between a high resolution RCM simulation and the driving GCM. *Meteorol. Atmos. Phys.* **100** (1–4), 73–86.
- Giorgi, F., Bi, X. & Pal, J. 2004 Mean, interannual variability and trends in a regional climate change experiment over Europe. II: climate change scenarios (2071–2100). *Clim. Dynam.* **23** (7–8), 839–858.
- Hellstrom, C. 2005 Atmospheric conditions during extreme and non-extreme precipitation events in Sweden. *Int. J. Climatol.* **25** (5), 631–648.
- Hundecha, Y. & Bárdossy, A. 2005 Trends in daily precipitation and temperature extremes across western Germany in the second half of the 20th century. *Int. J. Climatol.* **25** (9), 1189–1202.
- Jeong, J.-H., Walther, A., Nikulin, G., Chen, D. & Jones, C. 2011 Diurnal cycle of precipitation amount and frequency in Sweden: observation versus model simulation. *Tellus A* **63** (4), 664–674.
- Jones, R. G., Murphy, J. M., Noguer, M. & Keen, A. B. 1997 Simulation of climate change over Europe using a nested regional-climate model. II: Comparison of driving and

- regional model responses to a doubling of carbon dioxide. *Q. J. R. Meteor. Soc.* **123** (538), 265–292.
- Jones, P. D. & Reid, P. A. 2001 Assessing future changes in extreme precipitation over Britain using regional climate model integrations. *Int. J. Climatol.* **21** (11), 1337–1356.
- Lu, A. G., He, Y. Q., Zhang, Z. L., Pang, H. X. & Gu, J. 2004 Regional structure of global warming across China during the twentieth century. *Clim. Res.* **27** (3), 189–195.
- Maraun, D., Osborn, T. J. & Gillett, N. P. 2008 United Kingdom daily precipitation intensity: improved early data, error estimates and an update from 2000 to 2006. *Int. J. Climatol.* **28** (6), 833–842.
- Parry, M. 1989 The impact of climatic variations on agriculture. *Bull. Am. Acad. Arts Sci.* **42** (8), 30–36.
- Raisanen, J. & Joelsson, R. 2001 Changes in average and extreme precipitation in two regional climate model experiments. *Tellus A* **53** (5), 547–566.
- Richman, M. B. 1986 Rotation of principal components. *J. Climatol.* **6** (3), 293–335.
- Rotmans, J., Hulme, M. & Downing, T. E. 1994 Climate change implications for Europe: An application of the ESCAPE model. *Global Environ. Change* **4** (2), 97–124.
- Trömel, S. & Schönwiese, C. D. 2007 Probability change of extreme precipitation observed from 1901 to 2000 in Germany. *Theor. Appl. Climatol.* **87** (1), 29–39.
- Wibig, J. & Glowicki, B. 2002 Trends of minimum and maximum temperature in Poland. *Clim. Res.* **20** (2), 125–133.

First received 26 September 2012; accepted in revised form 11 June 2013. Available online 15 July 2013

Appended paper

VI

Rana, A., Bengtsson, L., Olsson, J. and Jothiprakash, V. (2013) Development of IDF-Curves for Tropical India by Random Cascade Modeling. *Hydrol. Earth Syst. Sci. Discuss.*, 10, 4709–4738, doi:10.5194/hessd-10-4709-2013

Earth System
Dynamics



Earth System
Dynamics
Discussions



Geoscientific
Instrumentation
Methods and
Data Systems

Open Access



Geoscientific
Instrumentation
Methods and
Data Systems
Discussions

Open Access



Geoscientific
Model Development

Open Access



Geoscientific
Model Development
Discussions

Open Access



Hydrol. Earth Syst. Sci. Discuss., 10, 4709–4738, 2013
www.hydrol-earth-syst-sci-discuss.net/10/4709/2013/
doi:10.5194/hessd-10-4709-2013
© Author(s) 2013. CC Attribution 3.0 License.

Hydrology and
Earth System
Sciences

Open Access



Hydrology and
Earth System
Sciences
Discussions

Open Access



This discussion paper is/has been under review for the journal Hydrology and Earth System Sciences (HESS). Please refer to the corresponding final paper in HESS if available.

Solid Earth

Open Access



Solid Earth
Discussions

Open Access



Development of IDF-curves for tropical india by random cascade modeling

The Cryosphere

Open Access



The Cryosphere
Discussions

Open Access



A. Rana¹, L. Bengtsson¹, J. Olsson², and V. Jothiprakash³

¹Department of Water Resources Engineering, Lund University, P.O. Box 118, Lund, 22100, Sweden

²Swedish Meteorological and Hydrological Institute, Norrköping, 60176, Sweden

³Department of Civil Engineering, IIT Bombay, Mumbai, 400 076, India

Received: 20 March 2013 – Accepted: 8 April 2013 – Published: 11 April 2013

Correspondence to: A. Rana (arunranain@gmail.com, arun.rana@tvrl.lth.se)

Published by Copernicus Publications on behalf of the European Geosciences Union.

Abstract

Efficient design of urban drainage systems is based on statistical analysis of past rainfall events at fine time scales. However, fine time scale rainfall data are usually lacking in many parts of the world. A possible way forward is to develop methods to derive fine time scale rain intensities from daily observations. This paper applied cascade-based disaggregation modeling for generation of fine time scale rainfall data for Mumbai, India from daily rainfall data. These data were disaggregated to 10-min values. The model was used to disaggregate daily data for the period 1951–2004 and develop intensity-duration-frequency (IDF) relationships. This disaggregation technique is commonly used assuming scale-invariance using constant parameters. For the Mumbai rains it was found better to use parameters dependent on time scale and rain volume. Very good agreement between modeled and observed disaggregation series was found for the time scales larger than 1/2 h for the 1/2-yr period when short term data were available. Although the parameters were allowed to change with time scale, the rain intensities of duration shorter than 1/2 h were overestimated. When IDF-curves had been established, they showed that the current design standard for Mumbai city, 25 mm h^{-1} , has a return period of less than one year. Thus, annual recurring flooding problems in Mumbai appear evident.

1 Introduction

Extreme weather events have severe consequences for human society, e.g. emergency planning, engineering design, reservoir management, and pollution control. Risk calculations rely entirely on knowledge of the frequency of these extreme events (e.g. Kumke, 2001). Assessment of extreme precipitation events is an important part of hydrologic risk analysis and design. Evaluation of rainfall extremes, as embodied in intensity-duration-frequency (IDF) relationship, has long been a major focus of both theoretical and applied hydrology, Langousis and Veneziano (2007). Rainfall frequency

analyses are used extensively in the design of systems to handle storm water runoff, including roads, culverts and drainage systems among other uses.

Access to fine time scale rainfall data is of prime importance for IDF analysis. However, such data of considerable length are usually not available in most parts of the world. A possible way forward is to develop necessary rainfall information from the commonly available daily rainfall data. Stochastic simulation tools can be used to extend historical data and generate new fine time scale data, which have similar statistical properties as the observed ones (Gaume et al., 2007). Stochastic disaggregation provides possibility of generating fine time scale rainfall data from coarser resolution. Traditionally there have been two approaches for this. One approach is based on fitting theoretical probability distribution functions to precipitation variables (e.g. Hershenhorn and Woolhiser, 1987; Econopouly et al., 1990; Connolly et al., 1998). The other approach starts from rectangular pulse stochastic rainfall models and devise ways to use these for disaggregation (e.g. Bo et al., 1994; Glasbey et al., 1995; Cowpertwait et al., 1996).

An approach to model the statistical distribution of rainfall in time and space that has emerged during the latest decades is by random cascade processes, Schertzer and Lovejoy (1987), Over and Gupta (1994) and many more. Random cascade models are also used for downscaling of precipitation. A cascade process repeatedly divides the available space into smaller regions, in each step redistributing some associated quantity according to rules specified by the cascade generator. A generic feature of random cascades is a scaling behaviour, which generally may be defined as a relationship between statistical moments of various orders and a scale parameter. The applicability of scaling and cascade models to temporal rainfall has been demonstrated in a number of empirical data analyses (e.g. Hubert et al., 1993; Olsson, 1995; Harris et al., 1996; Svensson et al., 1996; Tessier et al., 1993; Menabde and Sivapalan, 2000; Molnar and Burlando, 2005; Rupp et al., 2009; Licznar et al., 2011). Encouraging results for spatio-temporal disaggregation of rainfall have been reported. Rupp et al. (2009)

applied intensity- and time scale-dependent cascade models for disaggregating daily precipitation totals into hourly totals for the Christchurch Airport gauge in New Zealand.

The disaggregation studies performed to date have generally concerned model development, calibration, application and evaluation using extensive, high-resolution (time and volume), high-quality precipitation data bases. In practice however available high-resolution data for model calibration are often limited to data over short periods of data (e.g. from a measurement campaign) or data not always of the highest quality. Still, these kinds of data must be used in real-world applications supporting design of urban infrastructure. The Indian Meteorological Department (IMD) uses IDF relationships to estimate rainfall frequency for durations of 5 min up to 24 h. However, many stations do not have long data records for durations shorter than 1 day and therefore the character of short rainfall durations must be estimated from other sources.

In the present study the focus is on the Indian city of Mumbai (formerly called Bombay), which receives an average annual rainfall of 2142 mm with monsoon rainfall contributing for 96% of the total (Rana et al., 2012). During the monsoon period severe flooding occurs in many parts of the city. Potentially short term rainfall data could be used to improve the decision making process for various hydrological processes such as urban flooding mitigation. A random cascade model for disaggregation of daily rainfall to higher time resolution is employed, originally developed and fitted to rains in southern Sweden by Olsson (1998) and later used with data from British and Brazil stations, Güntner et al. (2001) and in semiarid areas of Tunisia by Jebari et al. (2012).

The key objectives of this study were to (1) test and apply the cascade-type disaggregation model to an area with very limited historical short-term observations. (2) Evaluate suitability and performance in a monsoon climate (India) and (3) assess the current design standards for storm water structures in Mumbai.

2 Methodology

2.1 Study area and data base

Daily accumulated rainfall data were obtained from the Indian Meteorological Department (IMD) for the period 1951–2004. The data were collected from IMD observatory at Colaba station (18°54' N, 72°49' E) in Mumbai which is situated at a height of 11 m a.s.l., the daily volume resolution is 0.1 mm. There is no missing data. Reference is made to Rana et al. (2012) for details of rainfall characteristics in Mumbai. Fine time scale data of 10 min interval was obtained from the same observatory for a period of 6 months, July–December 2006. The rain was measured with a tipping-bucket with volume resolution of 0.25 mm. The 2006 yr data were used to calibrate and evaluate the rainfall disaggregation model, estimate parameters, and define settings to fit the observed data using scale-invariant properties of rainfall time series. Descriptive statistics of daily data for both the datasets i.e. 1951–2004 and July–December 2006 are given in Tables 1a and 1b. January–June is a rather dry period and most of the rainfall occurs in the latter part of the year, i.e. July–December. It can be noted from the table that July–December in 2006 is much wetter (2170 mm) than the overall period of 1951–2004 (1643 mm). The highest volume of precipitation for 10, 30 and 60 min duration is 18.3, 24.1 and 41.7 mm. The more modest storms corresponding to 5th largest values in the 6-months period of 2006 are shown in Table 1b: 13.2, 20.8 and 28.2 mm for durations 10, 30, 60 min and 76.9, 117.0 mm for the longer durations of 12 and 24 h.

2.2 Disaggregation of daily rainfall

When short-term data is not available for design, rain intensities of short duration may be found from other cities. Relations between annual or seasonal precipitations at the two cities can be used for establishing IDF curves for the city, as done for Danish cities by Madsen et al. (2009) and for Swedish cities by Dahlström (1979). Another way of estimating short-term rainfall from observations over longer periods is by temporal

disaggregation. One approach along this line is to fit theoretical probability distributions to different rain characteristics (e.g. Tessier et al., 1993; Schertzer and Lovejoy, 1987, etc). Another approach is cascade-based disaggregation, combining an underlying hypothesis of cascade-type scaling with empirically observed features of temporal rainfall. The cascade-based disaggregation model for continuous rainfall time series used in this study is based on the principles suggested by Olsson (1998). Güntner et al. (2001) and Jebari et al. (2012) showed that the approach is applicable for cascading from 24 to 1 h duration in different climatic conditions. Constant, scale-invariant parameters were assumed, which were found to be climate dependent. The main difference compared with other cascade-based approaches is the assumption of dependency between the cascade generator and two properties of the time series values, rainfall volume and position in the rainfall sequence. Despite being built solely upon scaling properties, the model has been shown capable of reproducing not only the scaling behaviour of the observed data, but also the intermittent nature and the distributional properties of both individual volumes and event-related measures.

The rationale behind the disaggregation approach is to split each time interval (box) at a given resolution (for example 1 day) into two half of the original length (1/2 day). The procedure is continued as a cascade until the desired time resolution, i.e. first to 1/4 day, then to 1/8 of a day and so on. Each step is called a cascade step, with cascade level 0 as the longest time period with only one box (in the example a day). The rain volume of a box at an upper level can be distributed between the two lower boxes (probability $P_{x/x}$ or all the rain can go into either of the boxes (probability $P_{1/0}$ or $P_{0/1}$)). The distribution of the volume between the two shorter intervals (boxes) is determined by multiplication with the cascade weights (W), the distribution of which is often termed the cascade generator, which fulfils the prescribed properties. The process is repeated for a number of levels, defined by the cascade step cs , until the rainfall is disaggregated into the desired resolution. The principle is demonstrated in Fig. 1.

Through a random process it is first determined whether the rain volume should be distributed into two lower boxes or only into one of the probabilities ($P(x/x)$ or $P(1/0)$ or $P(0/1)$). If $P(x/x)$ was drawn in the random process, meaning that the rain volume should be distributed between two lower boxes, the distribution between the two boxes W_1 and $W_2 = 1 - W_1$ must be determined. In the original approach of Olsson (1998) and Güntner et al. (2001), the probabilities P and the probability distribution Wx/x are assumed to be related to (1) position in the rainfall sequence and (2) rainfall volume. Concerning the former, it is reasonable to assume that the parameters are different for long, continuous rainfall events of stratiform character as compared to short-duration, convective-type rainfalls. The wet boxes, i.e. time intervals with a rainfall volume $V > 0$, can be characterised from their position in the rainfall series. The position classes used in the present study are same as suggested by Olsson (1998) and are divided into four categories. A starting box is a wet box preceded by a dry box ($V = 0$) and succeeded by a wet box, an enclosed box is preceded and succeeded by wet boxes, an ending box is preceded by a wet box and succeeded by a dry box, and an isolated box is preceded and succeeded by dry boxes.

Concerning volume dependence, if the volume is large it is more likely that both halves of the interval contributes with non-zero volumes than if the volume is small. Olsson (1998) used two volume classes, below and above the median volume at the cascade step, with separate parameters. Since the focus of present study is the high and extreme intensities used for deriving IDF curves, a more detailed treatment of the probabilities' intensity dependence was found necessary. Firstly, a division into three volume classes ($vc = 1, 2, 3$) was used, separated by percentiles 33 and 67 of the values at the cascade step. Secondly, the variation of $P(X/X)$ with volume was parameterised as

$$P(X/X) = \alpha + \beta_m * vc \quad (1)$$

where α is the intercept at $vc = 0$, β_m is the mean slope of linear regression obtained from all cascade steps and vc is volume class (1–3). This is expected to give a sharper

description of the volume impact than the previous, simpler approach. Since, as found by Güntner et al. (2001), $P(0/1)$ and $P(1/0)$ are generally approximately equal they can be estimated as $P(0/1) = P(1/0) = (1 - P(x/x))/2$.

The main development of the methodology performed in this paper is to allow for the model parameters to vary also with time scale, as represented by the cascade step cs . Based on previous experience, this has emerged as a requirement for making the approach applicable at sub-hourly time steps. Therefore, in the present study $P(x/x)$ is related to time scale by letting one of the parameters (called α) to be dependent on cascade step. This is assumed to increase the possibility to describe the cascade redistribution of rainfall also at very short time steps, associated with the internal temporal distribution of rainfall events. A mean value is used for β , β_m and α and is varied with cascade step as:

$$\alpha = c1 + c2 * cs \tag{2}$$

where $c1$ and $c2$ are coefficients estimated from the aggregation process.

In Olsson (1998) the distribution of weights was determined from a uniform distribution so that $W = 0.1$ has the same probability as $W = 0.5$, at all cascade steps. Olsson (1998) found this valid when the lower box width exceeded at least $1/2$ h, i.e. going from one hour to half hour time. However, when going to boxes with shorter time width, the distribution was centred towards $W = 0.5$, the peak being most pronounced for the enclosed boxes. For box width exceeding a day, there was a tendency to an U-shaped distribution with probabilities of $W(x/x)$ close to 0 and to 1 were higher than for $W = 0.5$. Tests for the Swedish data, as well as data from other regions, have suggested that a symmetrical beta distribution provides a better fit to the observed distribution, as also used by e.g. Menabde and Sivapalan (2000). The symmetrical beta distribution is defined as:

$$f(x) = \Gamma(2a) / \Gamma^2(a) * x^{a-1} (1 - x)^{a-1} \tag{3}$$

where Γ is the gamma function and a is a parameter. The larger the parameter is, the more peaked is the distribution around $x = 0.5$. For $a = 1$, the distribution is uniform.

Based on own evaluation and previous experience in the literature, a reasonable scale-dependent parameterisation is a log-log linear function of cascade step cs :

$$\log(a) = c_3 + c_4 * \log(cs) \quad (4)$$

The disaggregation model parameters must be determined from an aggregation process, in the Mumbai case by using short-term 2006 rainfall data. Starting from the high resolution, say 10 min, of the available data, consecutive volumes from higher cascade levels (shorter time periods) are added two by two to get the volume at a lower level, say 20 min. In this aggregation procedure the weights W_1 and W_2 can be directly estimated as the ratio of each to the sum of the two volumes. By repeating this procedure to successively lower resolutions all weights can be extracted, the probabilities P , the distribution W/x , and their degree of scale-invariance assessed. The aggregation procedure was performed from the original 10-min resolution in seven cascade steps up to a time scale of $2^7 \times 10 \text{ min} = 1280 \text{ min}$ (21 h 20 min), which is the attainable time scale closest to 1 day.

After the cascade model parameters have been determined, the procedure of disaggregating daily data to gradually higher time resolution is straight-forward. First, through a random process it is determined whether the total rain volume in the interval should be distributed into both halves or only into one half (determined by probabilities $P(x/x)$, $P(1/0)$ and $P(0/1)$). Then if $P(x/x)$ was drawn in the random process, meaning that the rain volume should be distributed between the two halves, the weights W_1 and $W_2 = 1 - W_1$ are estimated by random sampling from a beta distribution with parameter according to Eq. (4).

Parameter estimation and settings defined to fit the observed data using scale invariant properties of observed rainfall time series were derived. The evaluation of the applicable scale range of the cascade model designed to represent the temporal structure of rainfall was performed as a first step. The probability values were estimated and weights were extracted. To do so, the observed 10-min time series were aggregated into daily values (1280 min) in the estimation step and then again disaggregated to

10 min values using 7 cascade steps and calibrated in the same series (Objective 1 of the study). This disaggregation was reproduced with 1000 realizations and means of empirical probabilities obtained after disaggregation were used as estimates of probability. The performance of model was investigated by disaggregating/redistributing the aggregated 2006 data and computing the statistics with the data; accounting for objective 2 of the study. This was then followed by disaggregation of the historical dataset; for objective 3 of the study. The temporal rainfall disaggregation was also done in 1000 realizations and the maxima were then used for analysis and establishing IDF curves. The procedure was shown in Fig. 2.

2.3 Establishment of IDF curves

The principal characteristics of a storm are its intensity, duration, total volume, and frequency or recurrence interval also called return period. Intensity-duration-frequency (IDF) analysis is used to capture the essential characteristics of point rainfall for shorter durations. IDF analysis provides a convenient tool to summarize rainfall information, and is used in municipal storm water management practice. In the IDF approach the rain intensity is the rain volume over a given time, the storm duration. The less the frequency of storm the stronger is the intensity.

IDF curves are developed by using long time series of rain observation to compute rain volume over fixed duration. In this study the disaggregated data produced in above procedure is used to compute IDF relations. The IDF analysis starts by gathering time series records of different durations by computing mean over fixed running time durations. Annual maxima were extracted from the records for all durations. The durations that were taken in consideration were 10, 20, 40, 80, 160, and 320 min. The annual extreme data was then fit to a probability distribution in order to estimate rainfall quantities of very low frequencies. The fit of probability distribution was performed in order to standardize the character of rainfall. Gumbel's extreme value distribution was used for fitting the extremes. For not so extreme events, the return periods can simply be

estimated from the number of events in ~50 yr data considered, for example the 5th largest value would correspond to 10 yr return period.

3 Results and discussion

3.1 Evaluation of random cascade model

The relationship between P and volume class at each cascade step was derived for the 2006 data. The probabilities $P(x/x)$ for all the four different type of boxes are shown in Table 2. The probabilities increase with the volume class; the wetter it is, the more likely that the rain is distributed into both halves of the interval. In order to use the equation $\alpha + \beta_m * vc$ a mean slope, β_m , was determined for each type of box. Thus, the slope β remains relatively constant for the different steps. However, the observed variation was modified to a fixed slope so that the intercept varied with cascade step. The α -values are not very dependent on the cascade step, but varied α -values gave somewhat better results. The assumed linear dependence on cascade steps is sometimes weak but based on earlier application of the model in different studies the linear assumption is kept. Moreover large variations in the data (attributed to short data period and associated variability) make it difficult to use any alternate model than the linear one. Overall the linear variation is in terms with the variation followed by the observed data. The probability $P(1/0)$ was found to be higher than $P(0/1)$ for ending boxes, but lower for starting boxes. For isolated and enclosed boxes the probabilities were the same. Since the number of enclosed boxes dominate, it is reasonable to assume the probabilities $P(1/0)$ and $P(0/1)$ to be same and equal to $(1-P(x/x))/2$ as suggested above.

Figure 3 shows fitted beta distributions (lines) to the empirical histograms (bars). The overall fit is reasonable at high cascade steps, i.e. large time scales, but when the number of values is small, and the histograms as well, the fits becomes uncertain. The distribution parameter is close to 1 for cascade step 3 and larger (3 h or shorter time scale). This is different from what was found in the Swedish study. This in contrast says

that the rain intensity may vary during a storm even for the time scales 10–20 min. As seen from the Fig. 3 some improvement is achieved when using the beta distribution as compared to a uniform distribution for the lower cascade steps. For the enclosed boxes, which dominate, and the isolated boxes the fit is good. Figure 4 shows how the beta distribution parameter a varies with cascade step. For starting and ending boxes, a is relatively constant and the joint mean appears to be a satisfactory approximation of the observed. This can be observed at each cascade step.

The results can to some extent be compared with earlier applications of the approach. In his Swedish study Olsson (1998) found the disaggregation technique to applicable for durations exceeding one hour. Since scale invariance did not apply for lower durations, he only briefly mentioned about his results for short durations and did not perform a serious analysis for the shorter durations. Güntner et al. (2001) concentrated on the one-hour rain volumes derived from disaggregation of daily data. Averaged over all cascade steps $P(x/x)$ was as high as 0.95 for enclosed boxes of high volume class for stations in Wales and Scotland with large annual precipitation (2500 and 1400 mm). For stations in Brazil with annual precipitation varying between 550 and 950 mm, $P(x/x)$ was about 0.7, and for a station in England with 600 mm annual precipitation it was 0.8. The w -distribution (step from 2 to 1 h) was peaked for the British stations indicating that the rain intensity is fairly uniform over an hour. When trying to fit to a beta-distribution the parameter a is about 3–3.5 for the wet volume class; there was only two volume classes in this study. For the tropical Brazilian climate the w -distribution is rather uniform. It is even so that for the wet volume class, the highest probabilities are for w close 0 and close to 1, which indicates intensity variations within the hour. This agrees with the Mumbai data, only that the same seems to be valid also for shorter time scales in Mumbai.

3.2 Performance of disaggregation model

The observed (data that was used for parameter estimation in cascade model i.e. July–December 2006) and the generated rainfall time series at different cascade steps in the

model are compared in Table 3. The agreement is very good for the three lower cascade steps (larger durations $\sim 24\text{--}6\text{ h}$) than at higher ones as noticed in terms of zero values, number of events more than 25 mm and maximum rainfall, mean and standard deviation (Table 3). At higher cascade steps the number of zero events and the mean is well determined but not the high values. The computed maximum is too low (about 20%) for durations 80 and 160 min, and much too high (around 40%) for durations 10 and 20 min. The aggregative property of the model is well preserved as the total rainfall in all the observed and generated series is equal to 2170 mm. The fraction of no rainfall periods and the number of large events are very well described when the duration is 6 h or more. Number of events more than 25 mm and percentage of zero rainfall are overestimated for 20 and 10 min data. Mean and S.D. are well preserved in all the cascade steps. Maximum values were preserved in lower cascade steps and deteriorate at cascade step 5 and above. Difference of up to 10mm is noticed in cascade step 7 when we have 10 min data. Overall the extreme values for 1 h durations and above are well preserved and are well related to observations presented by Deshpande et al. (2012), where the authors have studied observations from same station upto 1 h of temporal resolution.

The performance of the model is also shown in Fig. 5. The probability of zero rainfall, P_0 , was computed from generated data for the model at all scales $cs = 0, \dots, 7$ and compared with observed data according to Fig. 5a. The model performance was satisfactory for preservation of intermittency, with no differences at $cs = 0$ (1280 min), as by definition the model is conserving mass across the scales. The model performance was good in preserving the rainfall properties with relative percentage error ranging from -2 to -5% at each higher cascade step in terms of zero values. Daily rainfall maxima H_t and standard deviation of maxima $s(H_t)$ for the whole data period were determined from generated 10-min data for all 1000 realizations. This was done for every realization of generated data and compared with those derived from observed values for each cascade step and are presented in Fig. 5b and c. The model generally performed well with both means and standard deviation of maxima at each cascade steps

and same can be inferred from the box plots in Fig. 5b and c. The model has underestimated the mean of maxima in 1000 realizations as compared to observed values for first 4 cascade steps, equal in 5th cascade step and overestimated it in 6th and 7th cascade steps. Similarly S.D. is underestimated for first 4 cascade steps and equal in last three cascade steps inferring less variability in the generated data for 10, 20 and 40 min.

The model has thus overestimated the variability with longer durations i.e. lower cascade steps and equal in the higher cascade steps. Maximum daily values of generated daily rainfall are compared with that of observed in Fig. 6. It is seen that the model has performed well in preserving extremes upto 5 cascade steps as was shown in Table 3. The model seems to overestimate daily maximum values at 6th and 7th cascade steps. Güntner et al. (2001) report overestimation of the extreme one hour rain intensities, more so for the British stations than for the Brazilian stations. The disaggregation of the Mumbai-data shows clear overestimation of the number of events and of the extremes only when durations 10 and 20 min are considered. The intense storms are simulated well for time scale 40 min.

3.3 Establishment of IDF curves

After the parameters were determined and the disaggregation was performed on the 1951–2004 daily rain data, the new computed rain series were used to determine IDF curves as already discussed. The derived relations for Mumbai are shown in Fig. 7. From the graph it is seen that intensity and frequency of extreme events in Mumbai are quite high compared to the current design standards in the city. The intensity of 10 min duration rainfall is 125, 137 and 150 mm h⁻¹ for return periods of 20, 30 and 40 yr, respectively. 30 yr are considered the life expectancy of urban infrastructure and recommended by Central Public Health and Environmental Engineering Organisation (CPHEEO), Ministry of Urban Development, Government of India. For the same return period of 20, 30 and 40 yr, 30 min duration rainfall is 87, 95 and 102 mm h⁻¹, respectively, and 60 min duration is 60, 65 and 70 mm h⁻¹, respectively. This is high

compared to current design standard for Mumbai city which is only 25 mm h^{-1} at low tide (City development plan 2005–2025, Municipal Corporation of Mumbai). According to Intensity-Frequency relation of Fig. 7 it corresponds to return period of less than a year. The established extreme values from the IDF curves are comparable to those of a study performed by Deshpande et al. (2012) where the authors have outlined the extreme events for 1, 3, 6 and 12 h for Mumbai station. It can also be noted that 1 hr extreme rainfall for Mumbai in the study is 113 mm for the data period 1969–2004 which is comparable to the established IDF relations. It can also be said that the IDF relations hold true even when they are not adjusted to the overestimation of extreme values for cascade step 5 and above. This can be attributed to small dataset for comparison of the performance of cascade model.

Rainfall events are often used as the basis for determining the design capacity of the storm-water structures, but due to probabilistic nature of rainfall there is always a risk of exceedance of design capacity. There is always a hydrological risk associated with any design. The above technique for developing IDF curve from long daily precipitation series can be used for better design of storm water system and for risk analysis of cities not only in Mumbai but also for other cities with the same type of rains, where short-term data is lacking. It should be noted that most of the natural drains in Mumbai city are absent due to population pressure, developmental activities and/or encroachments in those areas. Man-made drains, need to be repaired or rebuilt. The present IDF curves can be used for planning drainage system in the city along with estimation of storm runoff, storm frequency, intensity of rainfall etc. Planners can decide upon drainage system based on level of performance or acceptable level of risk of the infrastructure system. It can be understood that the performance level of a given urban drainage system evolves with time. Many factors can modify the level of performance and the corresponding risk of system failure. Such factors are, for example, the addition of impervious surfaces, the extension of the network, structural aging of the network and the maintenance quality along with change in intensity and frequency of inflow into the

system. The response of the system to intense rainfall events is, to some extent, used as an indicator of the level of service provided, which has to be looked into for Mumbai.

4 Conclusions

In most cities there is a need of information about short-term rains for design of infrastructure. In the present study it was found that rainfall disaggregation can be used to derive short term rain information for tropical rains with about 30 min resolutions, when only daily data is available. It can help in providing fine time scale precipitation data necessary for many engineering and environmental applications. In the present study multiplicative cascade based model for disaggregation of rainfall was used. Strict scaling, i.e. parameters independent of time scale, was not used. For shorter times better agreement between model results and observations was found, when the parameters were allowed to vary with scale according to simple linear functions. The cascade weights' volume dependence was found to be significant; therefore three volume classes were introduced instead of the previously used two classes. Although, the parameters were related to time scale, the maximum values were overestimated for time scales less than about 30 min.

It should be emphasized that this is intended as a real-world demonstration case with limited possibilities for proper validation and uncertainty assessment. Even though the fitted model seemed to overall reasonably well reproduce key statistics over the whole range of time scales considered, distinct deviations were found and further no cross-validation was attainable. Clearly the deviations can partly be attributed to imprecise parameter estimates from the limited amount of short-term data available, but also the model structure and scale-dependent relationships are likely not strictly followed by the rainfall data. More in-depth analyses of the impact of high-resolution data availability on parameter estimation and model performance are clearly needed.

The IDF curves derived for Mumbai indicates that the present design standard values are very low. The design is for a storm with less than annual return period. Thus,

flooding is expected to occur several times in a year, which in fact also happens. In urban areas, it is very important to study the effects of urban conditions on rainfall–runoff relationships. Changes in the physical characteristics of urban areas change the runoff response of the area along with natural forces. Thus, it is necessary to evaluate the effects of changes in precipitation and human interference on the natural drainage patterns of the urban area. Infrastructural planning of urban area should require careful attention to urban drainage characteristics. This high intensity/frequency of precipitation is alarming and main problem for Mumbai.

Acknowledgements. The authors acknowledge support from the Swedish Research Council Formas and the Swedish International Development Cooperation Agency (SIDA).

References

- Bo, Z. Q., Islam, S., and Eltahir, E. A. B.: Aggregation-Disaggregation Properties of a Stochastic Rainfall Model, *Water Resour. Res.*, 30, 3423–3435, 1994.
- Connolly, R. D., Schirmer, J., and Dunn, P. K.: A daily rainfall disaggregation model, *Agr. Forest Meteorol.*, 92, 105–117, 1998.
- Cowpervait, P. S. P., O’Connell, P. E., Metcalfe, A. V., and Mawdsley, J. A.: Stochastic point process modelling of rainfall. II. Regionalisation and disaggregation, *J. Hydrol.*, 175, 47–65, 1996.
- Deshpande, N. R., Kulkarni, A., and Krishna Kumar, K.: Characteristic features of hourly rainfall in India, *Int. J. Climatol.*, 32, 1730–1744, doi:10.1002/joc.2375, 2012.
- Econopouly, T. W., Davis, D. R., and Woolhiser, D. A.: Parameter transferability for a daily rainfall disaggregation model, *J. Hydrol.*, 118, 209–228, 1990.
- Gaume, E., Mouhous, N., and Andrieu, H.: Rainfall stochastic disaggregation models: Calibration and validation of a multiplicative cascade model, *Adv. Water Resour.*, 30, 1301–1319, 2007.
- Glasbey, C. A., Cooper, G., and McGechan, M. B.: Disaggregation of daily rainfall by conditional simulation from a point-process model, *J. Hydrol.*, 165, 1–9, 1995.

- Güntner, A., Olsson, J., Calver, A., and Gannon, B.: Cascade-based disaggregation of continuous rainfall time series: the influence of climate, *Hydrol. Earth Syst. Sci.*, 5, 145–164, doi:10.5194/hess-5-145-2001, 2001.
- Harris, D., Menabde, M., Seed, A., and Austin, G.: Multifractal characterization of rain fields with a strong orographic influence, *J. Geophys. Res.-Atmos.*, 101, 26405–26414, 1996.
- Hershenhorn, J. and Woolhiser, D. A.: Disaggregation of daily rainfall, *J. Hydrol.*, 95, 299–322, 1987.
- Hubert, P., Tessier, Y., Lovejoy, S., Schertzer, D., Schmitt, F., Ladoy, P., Carbonnel, J. P., Violette, S., and Desurosne, I.: Multifractals and Extreme Rainfall Events, *Geophys. Res. Lett.*, 20, 931–934, 1993.
- Jebari, S., Berndtsson, R., Olsson, J., and Bahri, A.: Soil erosion estimation based on rainfall disaggregation, *J. Hydrol.*, 436–437, 102–110, 2012.
- Kumke, T.: Book Review: *Regional Frequency Analysis: An Approach Based on L-Moments* By J. R. M. Hosking and J. R. Wallis, Cambridge University Press, Cambridge, UK, 1997, 224 p., \$69.95 (U.S.), ISBN 0-521-43045-3 hardback, *Math. Geol.*, 33, 535–537, doi:10.1023/a:1011045130979, 2001.
- Langousis, A. and Veneziano, D.: Intensity-duration-frequency curves from scaling representations of rainfall, *Water Resour Res.*, 43, W02422, doi:10.1029/2006wr005245, 2007.
- Licznar, P., Łomotowski, J., and Rupp, D. E.: Random cascade driven rainfall disaggregation for urban hydrology: An evaluation of six models and a new generator, *Atmos. Res.*, 99, 563–578, 2011.
- Menabde, M. and Sivapalan, M.: Modeling of rainfall time series and extremes using bounded random cascades and levy-stable distributions, *Water Resour. Res.*, 36, 3293–3300, doi:10.1029/2000wr900197, 2000.
- Molnar, P. and Burlando, P.: Preservation of rainfall properties in stochastic disaggregation by a simple random cascade model, *Atmos. Res.*, 77, 137–151, 2005.
- Mumbai Municipal Corporation: “City development Plan 2005–2025, Chapter 2.6, Storm Water Drainage”, available at: <http://www.mcgm.gov.in/irj/portal/anonymous?NavigationTarget=navurl://095e1c7b9486b1423b881dce8b106978> (last access: 10 January 2013), 2005.
- Olsson, J.: Limits and characteristics of the multifractal behaviour of a high-resolution rainfall time series, *Nonlin. Processes Geophys.*, 2, 23–29, doi:10.5194/npg-2-23-1995, 1995.
- Olsson, J.: Evaluation of a scaling cascade model for temporal rainfall disaggregation, *Hydrol. Earth Syst. Sci.*, 2, 19–30, doi:10.5194/hess-2-19-1998, 1998.

- Over, T. M. and Gupta, V. K.: Statistical Analysis of Mesoscale Rainfall: Dependence of a Random Cascade Generator on Large-Scale Forcing, *J. Appl. Meteorol.*, 33, 1526–1542, doi:10.1175/1520-0450(1994)033<1526:saomrd>2.0.co;2, 1994.
- Rana, A., Uvo, C., Bengtsson, L., and Parth Sarthi, P.: Trend analysis for rainfall in Delhi and Mumbai, India, *Clim. Dynam.*, 38, 45–56, doi:10.1007/s00382-011-1083-4, 2012.
- Rupp, D. E., Keim, R. F., Ossiander, M., Brugnach, M., and Selker, J. S.: Time scale and intensity dependency in multiplicative cascades for temporal rainfall disaggregation, *Water Resour. Res.*, 45, W07409, doi:10.1029/2008wr007321, 2009.
- Schertzer, D. and Lovejoy, S.: Physical Modeling and Analysis of Rain and Clouds by Anisotropic Scaling Multiplicative Processes, *J. Geophys. Res.-Atmos.*, 92, 9693–9714, 1987.
- Svensson, C., Olsson, J., and Berndtsson, R.: Multifractal properties of daily rainfall in two different climates, *Water Resour. Res.*, 32, 2463–2472, 1996.
- Tessier, Y., Lovejoy, S., and Schertzer, D.: Universal multifractals: Theory and observations for rain and clouds, *J. Appl. Meteorol.* 32, 223–250, 1993.

Table 1a. Statistics of daily data for historical period (1951–2004), July–December 1951–2004 and July–December 2006.

Data Period	Daily Mean (mm)	Daily S.D. (mm day ⁻¹)	Mean Volume (mm)	Mean Annual daily Max (mm)	Maximum (mm day ⁻¹)
1951–2004	5.93	18.61	2165	162	293.4
July–December 1951–2004	8.97	21.76	1643	162	293.4
July–December 2006	13.64	34.06	2170	266	266

Table 1b. Statistics of short-term precipitation during July-December 2006.

Volume (mm)/ Duration	24 h	12 h	6 h	3 h	1 h	30 min	10 min
Largest	266	189	125.73	102.88	41.66	24.13	18.29
2nd Largest	196.05	124.71	100.84	65.53	40.39	22.61	16.76
3rd Largest	144	118.87	69.33	61.49	29.46	22.61	16.26
4th Largest	140.21	77.18	69.07	59.42	28.44	21.08	14.22
5th Largest	117.03	76.91	67.53	58.16	28.2	20.83	13.21

Table 2. Probabilities $P(x/x)$ as function of volume class, cascade step and type of box.

Isolated Box (β model = 0.15)								
Volume Class/ Cascade Step	1	2	3	4	5	6	7	Mean
1	0.00	0.00	0.19	0.06	0.04	0.00	0.00	0.04
2	0.16	0.25	0.24	0.12	0.25	0.10	0.08	0.17
3	0.43	0.36	0.31	0.38	0.40	0.36	0.22	0.35
α_{cascade}	-0.12	-0.11	-0.07	-0.13	-0.08	-0.16	-0.21	-0.12
α_{model}	-0.08	-0.10	-0.11	-0.12	-0.14	-0.15	-0.17	-0.12
Starting Box (β model = 0.22)								
1	0.19	0.07	0.08	0.09	0.09	0.21	0.21	0.13
2	0.30	0.32	0.23	0.19	0.45	0.35	0.29	0.30
3	0.42	0.53	0.44	0.55	0.53	0.58	0.62	0.52
α_{cascade}	-0.09	-0.09	-0.14	-0.12	-0.03	-0.01	-0.02	-0.07
α_{model}	-0.14	-0.13	-0.11	-0.10	-0.09	-0.08	-0.06	-0.10
Enclosed Box (β model = 0.29)								
1	0.45	0.35	0.28	0.25	0.26	0.47	0.59	0.38
2	0.85	0.75	0.67	0.66	0.73	0.81	0.86	0.76
3	0.97	0.93	0.91	0.94	0.91	0.89	0.95	0.93
α_{cascade}	0.21	0.13	0.07	0.07	0.09	0.18	0.25	0.14
α_{model}	0.12	0.13	0.13	0.14	0.15	0.16	0.17	0.14
Ending Box (β model = 0.23)								
1	0.15	0.00	0.07	0.09	0.05	0.03	0.07	0.07
2	0.42	0.37	0.18	0.31	0.48	0.29	0.62	0.38
3	0.52	0.56	0.47	0.44	0.60	0.41	0.64	0.52
α_{cascade}	-0.09	-0.14	-0.21	-0.17	-0.08	-0.21	-0.01	-0.13
α_{model}	-0.14	-0.13	-0.11	-0.10	-0.09	-0.08	-0.06	-0.10

Table 3. Rainfall characteristics related to the observed and model generated series from data period July–December 2006 (generated series data is mean of all 100 realizations).

Scale	Time Series	Zero Values (%)	No. of Events > 25 mm	Mean (mm)	S.D. (mm)	Maximum (mm)
1280 min	Observed	44.65	18	13.65	34.06	265.60
	Modelled	44.65	18	13.64	34.06	265.50
640 min	Observed	51.26	19	6.82	19.29	188.69
	Modelled	51.43	22	6.82	18.62	173.64
320 min	Observed	58.33	22	3.41	11.01	125.73
	Modelled	57.96	21	3.41	10.36	117.04
160 min	Observed	68.16	19	1.71	6.40	102.88
	Modelled	65.13	16	1.71	5.91	86.00
80 min	Observed	77.12	11	0.85	3.77	82.05
	Modelled	72.91	11	0.85	3.43	62.73
40 min	Observed	84.04	7	0.43	2.08	41.66
	Modelled	80.15	7	0.43	2.03	48.37
20 min	Observed	88.85	0	0.21	1.17	24.13
	Modelled	86.02	4	0.21	1.21	36.27
10 min	Observed	92.13	0	0.11	0.65	18.29
	Modelled	90.43	2	0.11	0.73	27.45

Cascade Step:

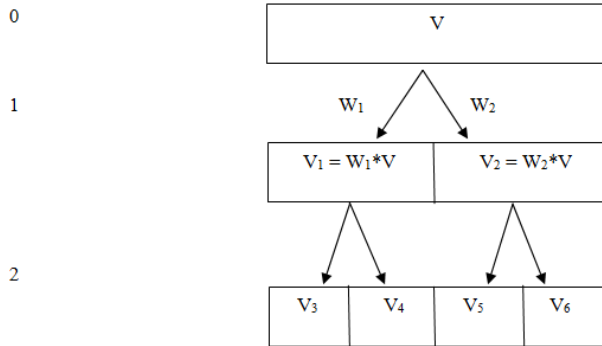

$$W_1, W_2 = \begin{cases} 0 \text{ and } 1 & \text{with probability } P(0/1) \\ 1 \text{ and } 0 & \text{with probability } P(1/0) \\ W_{X/X} \text{ and } 1 - W_{X/X} & \text{with probability } P(X/X) \end{cases}$$

where, $0 < W_{X/X} < 1$

$$\text{Volume} = V = V_1 + V_2 + V_3 + V_4 + V_5 + V_6$$

$$P(0/1) + P(1/0) + P(X/X) = 1$$

528

Fig. 1. Cascade process principle in one dimension. Between two cascade levels, each interval is divided into two halves. The volume in each half is obtained by multiplying the total interval mass by a weight W_i (after Olsson, 1998).

531 (after Olsson, 1998).

4732

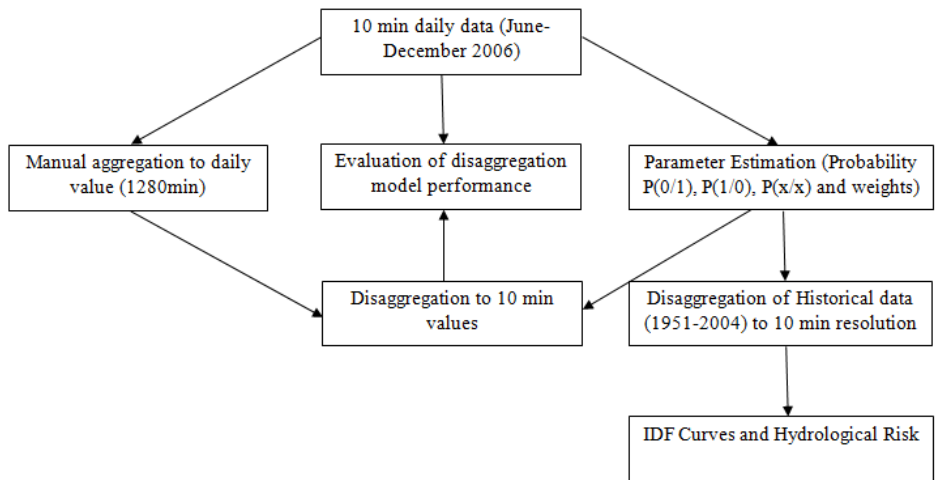
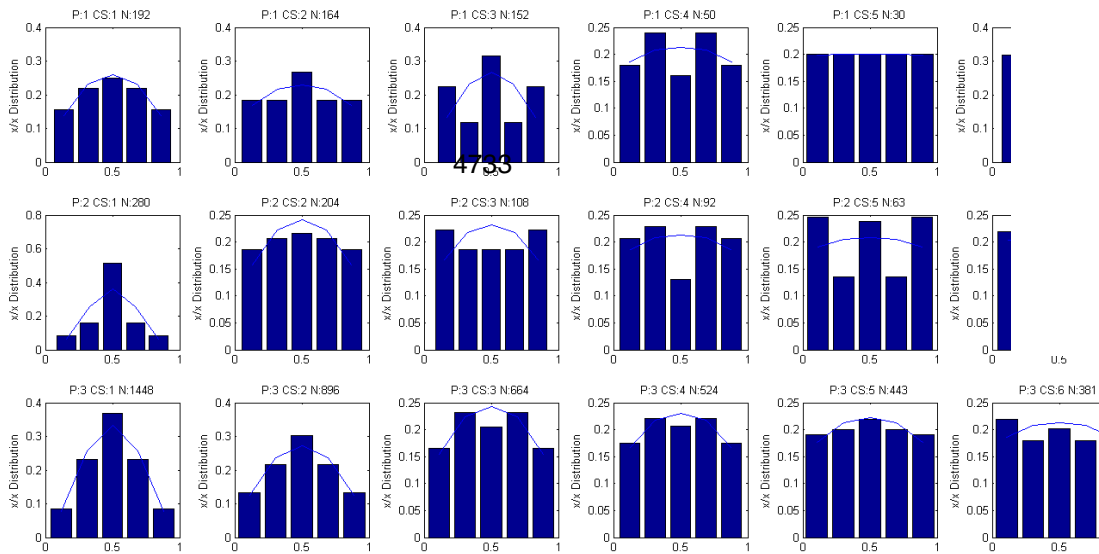
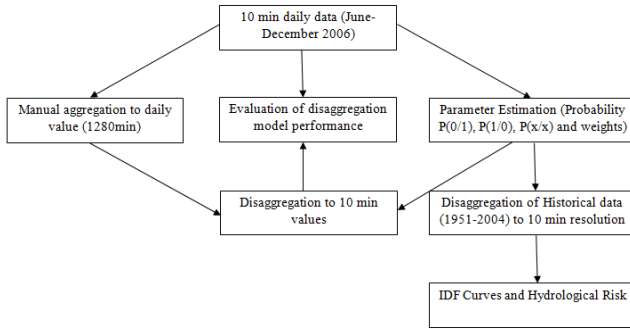

Fig. 2. Schematic representation of methodology adapted in the study.

Figure 2: Schematic representation of methodology adapted in the study





532

533 Figure 2: Schematic representation of methodology adapted in the study

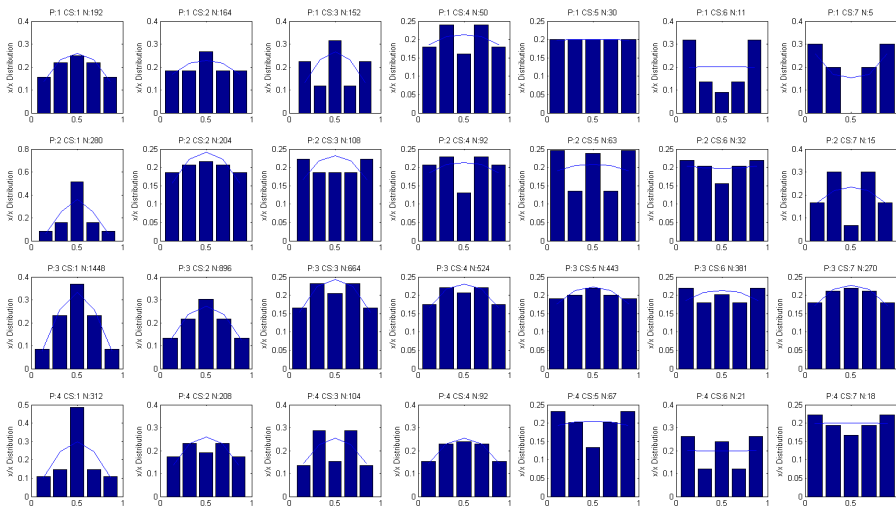

534

535 **Fig. 3** Variation of empirical x/x distribution with cascade step (bars) and fitted beta distribution
 536 (lines). In the diagram titles, P denotes position type (1: isolated, 2: starting, 3: enclosed, 4:
 ending), cs denotes cascade step (step 1 represents the “cascading” from 1280 to 640 min,
 step 2 from 640 to 320 min, etc.), and N denotes the total number of x/x -divisions for this
 position type and cascade step. 28

537 step (step 1 represents the “cascading” from 1280 to 640 min, step 2 from 640 to 320 min, etc.), and N
 538 denotes the total number of x/x -divisions for this position type and cascade step.

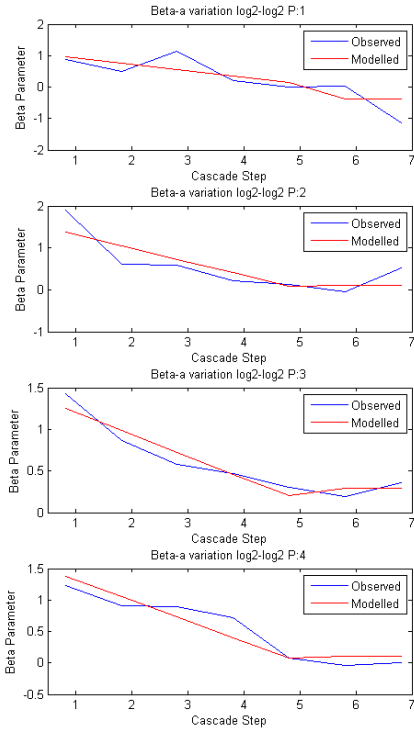
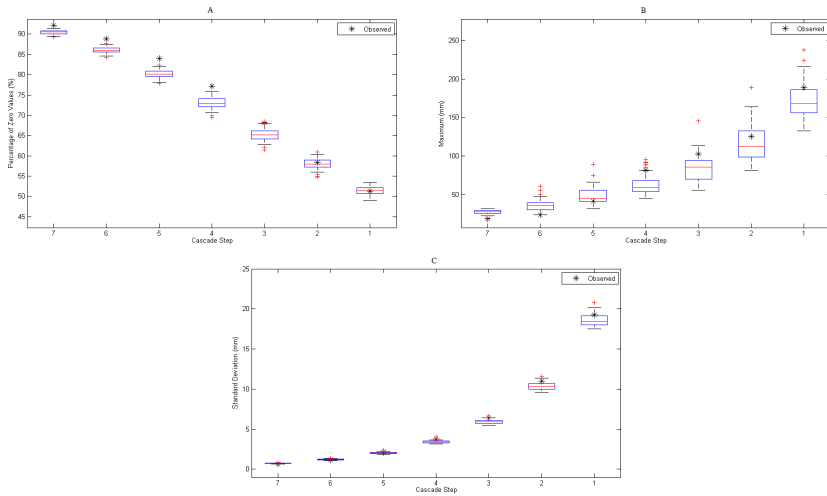

Fig. 4. Variation of beta parameter a with cascade step. In the diagram titles, P denotes position type (1: isolated, 2: starting, 3: enclosed, 4: ending).

540 Figure 4: Variation of beta-parameter α with cascade step. In the diagram titles, P denotes position type (1:
 541 isolated, 2: starting, 3: enclosed, 4: ending).



542

543 **Fig. 5. (A)** Preservation of the generated intermittency P_0 across scales with $cs=7$ (10 min) to $cs=0$
 544 $cs=0$ (1280 min) (left to right i.e. Cascade step from $cs=7$ to $cs=0$). **(B)** Preservation of the
 545 mean daily maximum and **(C)** Preservation of standard deviation in disaggregation for different
 546 cascade steps with observations. Bars give range of 1 S.D. (left to right i.e. Cascade step from $cs=7$ to $cs=0$). (Blue box in the figure represents
 547 25th and 75th percentiles with red line in middle as median; Red marks outside are outliers)

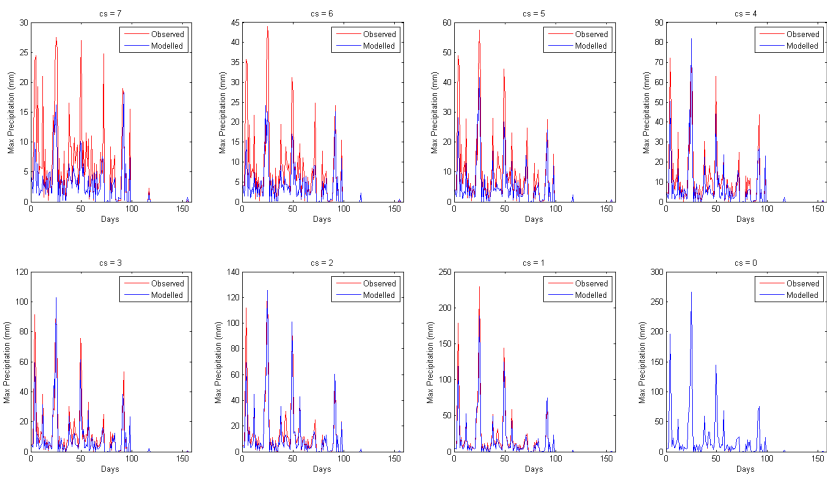

548

Fig. 6. Comparison of observed daily maximum values with generated daily maximum for each cascade step (Observed-Blue and Generated-red).

4737

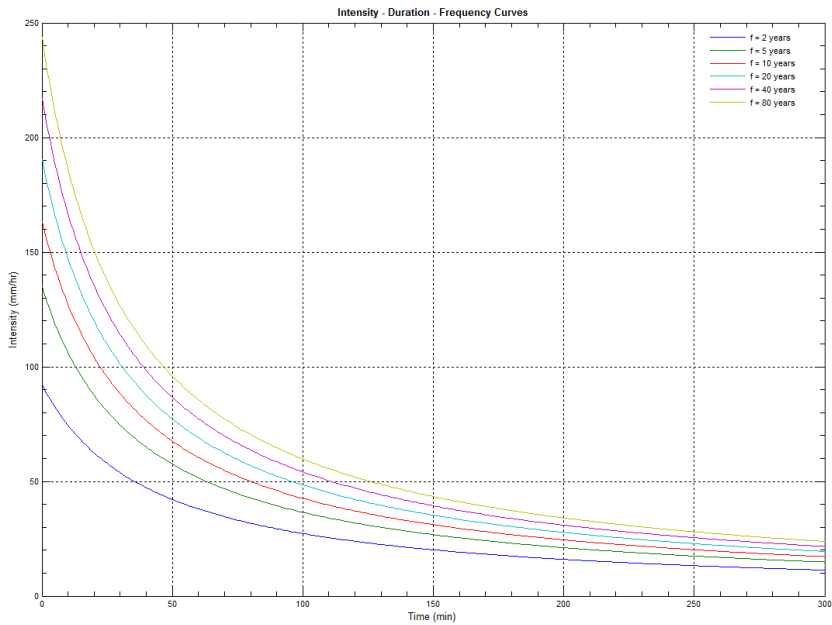

551

552 **Fig. 7.** Historical IDF curve for the city of Mumbai as represented by disaggregated data for period 1951-2004.

554

Appended paper

VII

Sørensen, J. and Rana, A. (2013) Comparative analysis of flooding in Gothenburg, Sweden and Mumbai, India: A review, CORFU, International Conference on Flood Resilience: Experiences in Asia and Europe, 5-7 September 2013, Exeter, United Kingdom.

COMPARATIVE ANALYSIS OF FLOODING IN GOTHENBURG, SWEDEN AND MUMBAI, INDIA: A REVIEW

Johanna Sörensen^{1,*}, Arun Rana¹

¹ Lund University, Sweden

* Division of Water Resources Engineering, Lund University, Box 118, SE-221 00 LUND, Sweden; Tel: +46 (0) 46 222 4487; E-mail: johanna.sorensen@tvrl.lth.se

ABSTRACT

To cope with flooding in cities, a combination of well working stormwater system and a resilient city is needed. As the future is uncertain, cities have to be built resilient, meaning that they can be flexible and adaptable, as it is not possible to protect the city from floods totally. Green areas in the city can provide resilience, as water can be led here e.g. during heavy rainfall. In this article the situation in Gothenburg, which is on the list of Swedish cities at risk of getting flooded, and Mumbai, where parts of the city is flooded every monsoon season, are compared. The sewage systems in Mumbai and Gothenburg were built in the same time period, late 1800's and early 1900's, both with British influences. The system in Mumbai has, more or less, not been developed since it was built, while the Gothenburg system has been developed along with the city expansion. Many parts of both cities were built on former marshland areas, close to the sea. Our recommendation, for both cities, is to develop the storm water systems further with sustainability and resilience perspectives in mind, including to build floodable areas close to the city centre. It is also important to educate leaders and practitioners in both cities about resilience and sustainability perspectives.

KEYWORDS

Awareness; city development; flood resilience; urban flooding.

1. INTRODUCTION

Floods are among the most powerful forces on earth, causing enormous damage all over the world. In the last decade, floods have killed about 100,000 persons and affected over 1.4 billion persons (OFDA/CRED, 2013). The statistics show that floods have a large impact on human well-being and economy. Economic damage, eco-system damage and historical and cultural values constitute direct consequences of flood. They lead to the loss of human life and cause human health effects (Hajat et al., 2005; WHO, 2002). Indirectly floods cause the loss of economic and agricultural production and a decrease of socio-economic welfare (Appleton, 2002). Previous studies focusing on floods and its impact includes, among others, Coates (1999) about the situation in Australia and Mooney (1983) and French (1983) about United States. Although every flood can be considered as a unique event with unique characteristics, patterns may be observed when a large number of floods are studied e.g. floods from rivers, precipitation, tides, etc.

In urban area perspective, prevention of flooding may be associated with inadequate sewer systems. With increased property values of buildings and other structures, potential damage from prolonged flooding can easily extend into millions of dollars. However, drainage systems designed to cope with the most extreme storms would be too expensive to build and operate. In establishing tolerable flood frequencies, the safety of the residents and the protection of their valuables must be in balance with the technical and economic restrictions. Knowledge of the social system and its vulnerabilities is still weakly developed, even though it is a key element of the social response to a flood and of the urban dynamics (Hall et al., 2003). The response of the drainage system to rain events in the urban environment is characterized by two main components, the first being the surface runoff on natural slopes; the second component consists of the artificial drainage system and levelling of constructions in the city. In most of the cities, the artificial drainage system is controlled by a combined sewer network, which collects both stormwater and wastewater to the treatment plant.

Since planners must cope with uncertainty (Godschalk, 2003) and a flood-event always can be bigger than what the system is designed for (Liao, 2012), cities must be built resilient. An urban resilience to floods could be conceptualized as *the capacity to remain in a desirable regime while experiencing a*

flood (Liao, 2012). While a *flood resistant city* can resist floods to a certain degree, but not bigger floods, a *flood resilient city* is flexible and adaptive, and learning from historic events. It is in many cases not possible for a city to be both resistant and resilient. A city that accepts smaller floods, will be better prepared when a bigger flood occur. To be able to handle floods, floodable areas are needed in the city (Liao, 2012), i.e. areas that can store or convey water without incurring damage.

The effects associated with global warming, such as sea level rise, more intensive precipitation and higher river discharges, may increase the frequency and the extent of flooding on a worldwide scale. The frequency of floods has been demonstrated to already have increased during the twentieth century (Milly et al., 2002). Global average precipitation is projected to increase, but both increases and decreases are expected at the regional and continental scales (IPCC, 2001). Global population growth, more intensive urbanization in flood prone areas and the limited development of sustainable flood-control strategies will increase the impacts of floods. As global warming makes the risk of flooding higher in cities, the demand for sustainable city planning is growing.

Heavy rainfall on 26th and 27th July 2005 led to massive floods in Mumbai, India. The unprecedented rainfall of 994 mm during the 24 hours resulted in that at least 419 persons were killed (Gupta, 2007). It caused, as a result of the following flash floods and landslides in the Mumbai municipal area, death of another 216 from flood-related illnesses and the direct economic damages were estimated to almost two billion USD and many more indirect monetary damages (Hallegatte et al., 2010).

Gothenburg, Sweden has also seen flooding recently. In December 2006, heavy rainfall (311 mm) during more than 2 weeks resulted in high river flow. The return period was estimated to 10–50 years and high sea water level aggravated the situation. Many buildings were flooded, and traffic on both rails and roads were stopped. Due to landslide, there were traffic problems in the area for a long time. In December 2011, Gothenburg were again flooded due to high flow in combination with high water level in the sea. The water level was 146 cm above mean sea level and 52 mm of rain fell in 48 hours.

This study investigates the flooding problems and its consequences in India and Sweden. Since 1900, 11 people in Sweden and 60,000 persons in India have been killed because of flooding (OFDA/CRED, 2013). Mumbai and Gothenburg have been chosen due to the characteristic features of flooding in the area. The objectives of the study includes an overview of flooding situation in both cities, consequences of flooding and damage caused by it and finally to assess whether the cities are working in a direction of resilience and sustainability to avoid substantial damage in future. It would provide insight in the magnitude of loss, both social and economic, due to floods and problems faced in the cities.

2. STUDY AREA

2.1 Mumbai

The East India company started development of Mumbai as a naval base, which subsequently metamorphosed as a large port with flourishing trade and commerce. The city has now developed into commercial capital of the country with 13 million habitants. The population density is around 50,000 persons/km².

Mumbai is lined by the Arabian Sea on the western side and intercepted by creeks and rivers. The drainage system of Mumbai is a mix of simple drains (nallah) and a complicated network of rivers, creeks, drains and ponds built around 80 years back (Figure 1). At present, the stormwater drainage system consists of a hierarchical network of roadside surface drains (mainly in the suburbs), underground drains and laterals (in the island city area), major and minor nallahs and 186 outfalls. All surface runoff discharges into the rivers and the Arabian Sea. Table 1 represents the summary of stormwater drains in Mumbai with their length in km (MCGM, 2005). A network of closed drains below the roads has evolved in the city along with drains in the suburbs. Reference is made to Rana (2011) for details on the Mumbai drainage system.

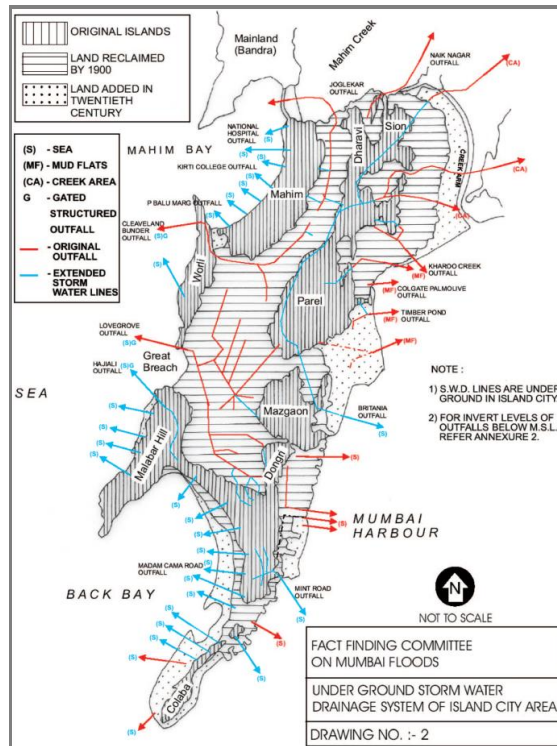

Figure 1: Drainage of Mumbai City area, Gazetteer of India, Maharashtra State, History of Bombay, Modern Period 1987 (Govt. of Maharashtra, 2006).

Table 1. Summary of the stormwater drainage system of Mumbai (Govt. of Maharashtra, 2006) and Gothenburg (Göteborg Vatten, 2012)

Pipe type	Length [km]	
	Gothenburg	Mumbai
Closed combined drains (stormwater and sewage)	398	565
Major open combined drains	N/A	200
Minor open combined drains/roadsides drains	N/A	2074
Stormwater only	878	N/A
Stormwater (pump system)	1	N/A
Tunnels stormwater	12	N/A
<i>Total pipe length, stormwater system (combined and separate)</i>	<i>1289</i>	<i>2839</i>
Sewage only	993	N/A
Sewage (pump system)	197	N/A
Tunnels sewage	16	N/A
<i>Total pipe length, sewage system</i>	<i>1206</i>	<i>N/A</i>

Greater Mumbai has witnessed rapid growth of built up areas in past four decades, i.e. 1971–2001. The built up areas has more than doubled from about 25% in 1971 to 52% in 2001. The shift is from

coastal wetlands and agricultural/forestlands into urban areas. Coastal wetlands have experienced a substantial decrease from 29% to 19% and land under forests has reduced from 32% to 19%.

The region as whole is a lowland, lying on the west of Sayhadri hill ranges. The step-like terraces and layered appearance is characteristic of the deccan lava country. The river system consists of five major rivers that drain into the Arabian Sea.

Climatic conditions in the Mumbai region, especially in the summer season, are oppressive because of the high temperature associated with high humidity. Monsoon season brings in heavy rains that averages 2150 mm per annum (Rana et al., 2012). Very heavy rains with intensity of 250 mm/day are not uncommon ($T \approx 2y$), leading to major problems of flooding in the area. Most of the rainfall is received in monsoon season (June–September), accounting for 96% of annual rainfall (Rana et al., 2012). The hourly intensity of rainfall for return period of 20, 30 and 40 years are 60, 65 and 70 mm/hr, respectively (Rana et al., 2013).

2.2 Gothenburg

Gothenburg is the second largest city of Sweden, situated at the mouth of Göta River with the harbour as an important part of the export industries. Gothenburg has a population of 526,000 inhabitants (December 2012) (SCB, 2013a). The area of Gothenburg is 450 km² and the population density is 1,200 persons/km² (SCB, 2012).

The Gothenburg soil condition are stony hills with clayey soils in the low-lying areas between. Only few areas are lying on sandy soils. The clay layer in central Gothenburg is at some places over 100 meters. Göta River, with a catchment of 50,000 km² (SMHI, 2010), and the tributary Mölndal River, are flowing through the city centre. Most parts of the riversides are covered with buildings. There are concerns about landslides along the rivers (Göteborg Stad, 2006). The flow in Göta River are controlled by an upstream hydropower plant with maximum draft of 1000 m³/s (SMHI, 2005).

The climate in Gothenburg is typical for a coastal city in the temperate continental climate. The rainfall is more or less constant during the year, with monthly precipitation on 40–83 mm (SCB, 2013b). Long dry periods can occur. The hourly intensity of rainfall for return period of 20, 30 and 40 years are 30, 32 and 34 mm/hr, respectively (recalculation with Gumbel distribution of intensities from Hernebring (2006)). In the summer, temperature daytime are about 18–25°C and in the winter a bit under 0°C with snowfall and ice on lakes. Main wind direction is from west, i.e. the sea.

The sewage system covers an area of 163 km² of Gothenburg. 20% of this is combined system (Göteborg Stad et al., 2007). Length of the pipe system can be seen in Table 1. According to Jansson (2012), the separate stormwater system of Gothenburg is mainly designed for a return period of two or five years. The combined system is design not to give flooding more often than every ten year. The separate wastewater system are designed never to get flooded, but due to construction mistakes and pumping failures, there are 20–200 cases of flooding every year.

In Gothenburg, the development of an urban drainage system has been driven by the need for sanitation in the city and at least two of the main plans (1866 & 1894) have been initiated because of cholera epidemics. In 1866, J.G. Richert wrote a sewage plan. He wanted to implement water closets, pumping of water from lower areas and treatment of the sewage to utilize nutrients from the water. This was unrealistic at the time and he therefore suggested pipes that could lead the water from every house and road to the inner canals of Gothenburg. During the next 20 years a system with about 20 km pipes was constructed. As the inner canals became smelly, intercepting sewage that lead stormwater and sewage to Göta River directly, was constructed along the canals. The idea came from England, where six tunnels had been constructed in London in 1859–1865. The plans in mid-19th century were inspired by the drainage systems in English cities. Later in the 19th century, inspiration came from German cities as well. In this period, the city grew with new, drained areas like Masthugget. In the beginning of the 20th century, water closets were implemented and the drainage system was developed further: pipes led water to low-lying areas from where it was pumped. The sewage system grew together with the city. Until 1958, combined sewage was still constructed. From 1958, all new areas were built with separate system. In the 60's and 70's there was a focus on reconstruction of the old, combined system to separate system, but this was stopped in the 70's due to high costs and, as mentioned before, 20% of Gothenburg has still combined system. (Bjur, 1988)

3. FLOODING – PRESENT SITUATION AND FUTURE STRATEGIES

3.1 Mumbai

The core of the present SWD (storm-water drainage) in Mumbai is about 70 years old, built during the British rule in India, comprising about 400 km of underground drains and laterals built based on population and weather conditions at that time. This old SWD system is only capable of handling rain intensity of 25 mm/hr at low tide. Flooding occurs often with high intensity rains and high tide in sea. Tidal variations have huge impact on flooding and water logging situation as all the discharge from SWD and treated sewage is into the Arabian Sea. Runoff from the city is retarded causing high water stage on the streets because of flat gradients, mud flats, manmade inappropriate levels of outfalls, poor placement of gullies, loss of holding ponds due to land development, new impermeable surfaces, encroachments on drains, enhanced silting and choking of drains due to sillage/sewage inflows and garbage dumping in drains, obstruction due to crossing utility lines, etc. Key issues and strategic plans according to Mumbai Municipal Corporation are outlined in Table 2.

Table 2: Key issues and strategic plans for the city of Mumbai

Key Issues	Strategy options/plans
<ul style="list-style-type: none"> • Encroachments alongside drains, disturbing catchments runoff • Adulteration of stormwater in drains by garbage and sewage infusions, which are in turn discharged into the environmentally sensitive creeks and the sea • Increase in overall runoff coefficient • Silting of drains and poaching of space by utility lines, reducing carrying capacity • Structural deficiencies due to age and poor workmanship 	<p>Various recommendations suggested by the BRIMSTOWAD report 1993 and subsequent studies:</p> <ul style="list-style-type: none"> • Divert sullage water flow to sewage pumping station, improve flood gates at various places and increase the capacity of drains wherever necessary • Remove obstruction of water pipe lines, cables etc. from SWD • Widen, deepen and extend the nallahs and outfalls, remove encroachments along the nallahs/drains and rehabilitate them • Desilt and maintain stormwater drain during rainy season
<p>Project implementation hurdles:</p> <ul style="list-style-type: none"> • Encroachment removal and relocation • Multiplicity of agencies associated with permissions, ownership of water channels/bodies • Shifting of utilities • Lack of funding sources (projected cost is around 3 billion USD) 	<ul style="list-style-type: none"> • Formation of coordination committee comprising representatives from all associated stakeholder agencies to sort out institutional/procedural issues • Framing and implementation of slum rehabilitation plan to rehabilitate displaced families due to encroachment removal and land rehabilitation • Generation of funds required through a combination of routine budgetary allocation, enhanced revenue through financial reforms, special levy for SWD improvement and additional grants from State/Central government

In the backdrop of ever changing externalities due to globalisation, Mumbai needs to be prepared to adopt a systematic change of urban fabric to overcome the threats of rising population, limited resources, limited capacity of infrastructure stock and decelerating economy. The quality of life in Mumbai has worsened and the decline is quite steep. Slums have proliferated and congestion, pollution and water problems have increased. As per the city development plan for 2005–2025 of Mumbai, development of city will depend on various strategies across sectors to address the needs of its citizen and ensure socio-culturally and environmentally safe city.

3.2 Gothenburg

As a part of the work with the EU directive, 2007/60/EC, Swedish Civil Contingencies Agency (MSB) has finished an assessment where Gothenburg is considered as one of the 18 Swedish cities at risk of flooding (MSB, 2011). Gothenburg is one of seven cities matching all five criteria in the assessment. Higher precipitation and sea level rise are expected in the future due to climate change (Göteborg Stad, 2009).

SMHI made a mapping of flooding from Göta River in 2000 and Mölndal River in 2008. According to the SMHI (2000) and SMHI (2008), Gullbergsvass in central Gothenburg is at risk of getting flooded by the Mölndal River with a return period of 100 years (Figure 2, right). The central station, the railway and several buildings along Mölndal River are situated in the risk area. The analysis was conducted with a 1D-model with interpolation of the water level on the surface with a rough digital elevation model (DEM). According to MSB (2011), 2,800 persons are living in the area that would get flooded by a 100-year flow in Göta River. 21,000 persons are working in the same area.

No general mapping of flood risk from heavy rainfall has been done for Gothenburg. However, several minor studies have been conducted for smaller areas of interest, leading to a good overview for the city planners (Ljunggren, 2013).

In 2006, Gothenburg Municipality made an assessment of consequences of flooding from the sea (Göteborg Stad, 2006). They came up with a minimum level under which no new buildings are supposed to be built. They also suggest building a pilot test area with the principles of SUDS (sustainable urban drainage system). This area is suggested to be Södra älvstranden, Norra älvstranden or Gullbergsvass, which are low-lying areas. Other topics on the agenda are to spread awareness among all branches of the municipality, find out how to protect valuable constructions, show the river flow on the Internet, make a risk assessment of the city and to make responsibilities for climate change effects clear (Göteborg Stad, 2010).

4. RESILIENCE AND SUSTAINABILITY PERSPECTIVES

Reforms are fundamental to improve the situation in Mumbai. The Municipality Cooperation of Greater Mumbai (MCGM) has embarked on various innovative measures and reforms program in several areas of its operation. Remedial measures suggested for improving the situation in Mumbai (MCGM, 2005) includes complete review of the drainage design, de-silting and improvements to the watercourses before monsoon and improvement in municipal solid waste management system. They also suggest restoration of the existing degraded rivers and riverbanks to initiate recovery of the urban ecosystem. Degraded urban ecosystems (lakes/ponds, rivers, creeks, and coastal zones) need to be rejuvenated and monitoring of environmental and ecological status-related activities strengthened.

The stormwater management also includes regulating the use of land in flood plain to restrict or reduce the damage caused by floods. The stormwater runoff coefficient is said to have increased, which has necessitated re-designing the stormwater system for Mumbai. Therefore, the design criteria has been changed from 25 mm/hr to 50 mm/hr for rainfall intensity and runoff coefficient set to 1.00 (earlier 0.50). Plans for avoiding loss of drainage capacity by way of proper maintenance shall also explore the possibilities of reducing the run-off. Besides maintaining existing open spaces as ponding areas, nonconventional methods like rainwater-harvesting, introducing "porous paver blocks" for pavements and provision of detention/retention ponds can be effective to reduce storm run-off. This retained run-off can subsequently be let off in the stormwater system during lean times. Mumbai's systems will have to be managed keeping the principles of sustainable development in view and encouraging wide participation through partnerships and networking institutions.

In 2009, Gothenburg Municipality passed a new core strategy (Göteborg Stad, 2009). The plan is headed for the next 20 years and includes 13 strategic objectives where *Resilient city* are most relevant for the flooding issue. In addition, *More housing* and *Changed transport requirements* are linked to the flooding problem, as a more dense city potentially could cause higher risk for flooding. According to the core strategy, building a resilient city requires a flexible and aware planning with safety margins in the construction. An important decision in Gothenburg is to never build new, vulnerable functions or buildings lower than +2.8 meters from the mean sea level (Göteborg Stad, 2008). In addition,

permanent flood dikes and walls, temporary walls and building a floodgate at the estuary of Göta River are discussed. Close to the city centre, a bigger urban renewal project will take place (Figure 2, left). Industrial areas will be transformed to mixed areas with housing, parks and social services. The area is low-lying, at the waterfront of the harbour. Future higher water levels need to be considered in this area (Göteborg Stad, 2009). Parts of the areas planned for transformation are considered at risk of flooding, see Figure 2 (right). The projects have been criticised, as parts of the area are already today sensitive to flooding (Hjerpe and Glaas, 2012). The demand for building barriers along the river to avoid flooding increases as these areas are developed. According to Ljunggren (2013), though, the need for barriers is already there.

Gothenburg has no bigger green areas in the city centre or close to the riverside, which makes the city static and not resilient. Most of the green areas are in the hills, where they are least needed when it comes to flood resilience. Cettner et al. (2012) describes how the stormwater system in Sweden today are caught in old structures, with a pipe-bound system that cannot be developed to more nature-oriented and local solutions without breaking social-institutional barriers (Cettner et al., 2012; Stahre, 2008). Gothenburg is now implementing strategies to build more resilient in newer areas, inspired by the Swedish Water & Wastewater Association's report no. P105, but it seems like they do not consider this is the old areas, except for the pilot test area mentioned in chapter 3.2.

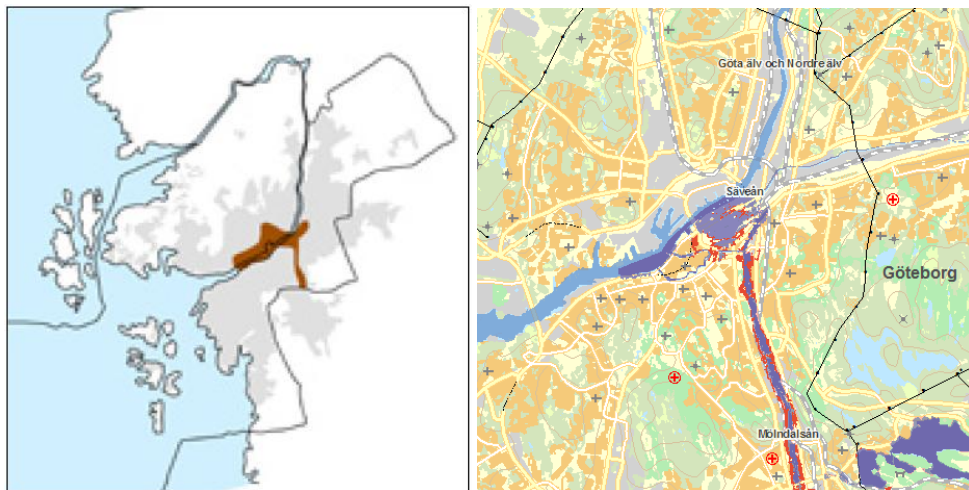

Figure 2: *Left*: areas in the city centre planned to be developed into dense housing areas, marked with brown, according to Göteborg Stad (2009). Gothenburg itself is marked with grey. *Right*: areas at risk of flooding, marked with blue/red, according to SMHI (2000) and SMHI (2008).

5. CONCLUSION

In this article, insight in the magnitude of loss, both social and economic, due to floods and problems faced in the cities of Gothenburg and Mumbai have been provided. The sewage systems in Mumbai and Gothenburg were built in the same time period, late 1800's and early 1900's, both with British influences. The system in Mumbai has not developed since it was built, while the Gothenburg system has been developed along with the city expansion. Many parts of the city were built on former marshland areas in both cities, close to the sea. Gothenburg city struggles with rising sea level in the future and has seen a few severe flood events in the last years, while parts of Mumbai are flooded during the monsoon season every year.

Gothenburg city wants to cope with climate change by being restrictive in building on low-lying areas, but the low-lying areas are close to the city centre and attractive for building. Important buildings and constructions in the city centre are at risk of flooding when the sea level rises. It seems like Gothenburg is more heading for flood resistance, building high floodwalls to prevent from flooding with a certain return period, instead of building a flood resilient city, with floodable areas in strategic places.

The main problem in the Mumbai drainage system is clogging from solid waste, authorities with overlapping responsibilities, low level of awareness among citizens and problem with relocation of slums. The work for flood resilience and work against poverty must go hand in hand, as the areas along the open stormwater system (creeks and rivers) are needed as floodable land. The same areas are today slum areas where people need better housing. Mumbai are struggling with severe flooding every monsoon season. There is huge loss of life and property due to floods. Large areas are under heavy stress, and the situation is especially hard to solve due to high population density and no new land to build on. The municipality corporation in Mumbai is working on all aspects of flood prevention and control, but economic instability is a huge drawback. They are working mainly with flood forecasting and management systems, emergency response, de-silting of main drains before monsoon season, and redevelopment of drainage system according to the increased capacity along with education for awareness.

Our recommendation, for both cities, is to develop the storm water systems further with sustainability and resilience perspectives in mind, including to build floodable areas close to the city centre. We are concerned about the high risk for lives in Mumbai, and the willingness in Gothenburg to build in low-lying areas. The problems in Mumbai are much bigger, because of the insufficient storm water system and the climatic conditions, and harder to solve, as the population density is very high. In Gothenburg, the low frequency of floods today might be a problem when it comes to local awareness. The flood risk of tomorrow seems to be forgotten in the overall city development planning. In this perspective, building of a resilient system might be easier Mumbai, as the every-year monsoon season is a good reminder of the importance of good storm water management. It is important to educate leaders and practitioners in both cities about resilience and sustainability perspectives.

6. REFERENCES

- Appleton, B. (Ed.), 2002. *Climate Changes the Water Rules, Dialogue on Water and Climate*. Printfine Ltd., Liverpool, UK.
- Bjur, H., 1988. *Vattenbyggnadskonst i Göteborg under 200 år (Water architecture in Gothenburg for 200 years)*. Göteborgs VA-verk, 226 pp.
- Cettner, A., Söderholm, K., Viklander, M., 2012. An adaptive stormwater culture? Historical perspectives on the status of stormwater within the Swedish urban water system. *Journal of urban technology*, 19(3): 25-40.
- Coates, L., 1999. Flood fatalities in Australia, 1788–1996. *Aust. Geogr.*, 30(3): 391-408.
- French, J., Ing. R., von Allmen, S., and Wood, R., 1983. Mortality from flash floods: A review of the national weather service reports, 1969–1981. *Public Health Rep.*, 98(6): 584-588.
- Godschalk, D.R., 2003. Urban hazard mitigation: Creating resilient cities. *Nat. haz. rev.*, 4(3): 136-143.
- Govt. of Maharashtra, 2006. Report of the Fact Finding Committee (FFC) on Mumbai Floods, Mumbai.
- Gupta, K., 2007. Urban flood resilience planning and management and lessons for the future: a case study of Mumbai, India. *Urban Water J*, 4(3): 183-194.
- Göteborg Stad, 2006. *Extrema vädersituationer – hur väl rustat är Göteborg? (Extreme weather situations – How well-prepared are Gothenburg?)*.
- Göteborg Stad, 2008. *Havsnivåhöjning och samhällsviktiga anläggningar (Sea level rise and installations important to the society)*.
- Göteborg Stad, 2009. *Översiktsplan för Göteborg (Core strategy for Gothenburg)*.
- Göteborg Stad, 2010. *Handling 2010 nr 21: Extrema vädersituationer, fas 2 (Report 2010 no 21: Extreme weather situations, phase 2)*.
- Göteborg Stad, Gryaab, *Urban water*, 2007. *Systemstudie avlopp: en studie av framtida, hållbara system för hantering av avlopp och bioavfall i Göteborgsregionen (System study sewage)*.
- Göteborg Vatten, 2012. *Nyckeltal för Göteborg Vatten 2011 (Key figure for Gothenburg Water 2011)* [Online]. Available: <http://goteborg.se/wps/portal/enheter/fackforvaltning/goteborg-vatten> [Accessed 2013-03-25].
- Hajat, S. et al., 2005. The Human Health Consequences of Flooding in Europe: a Review. In: Kirch, W., Bertollini, R., Menne, B. (Eds.), *Extreme Weather Events and Public Health Responses*. Springer Berlin Heidelberg, pp. 185-196.
- Hall, J., Meadowcroft, I., Sayers, P., Bramley, M., 2003. Integrated Flood Risk Management in England and Wales. *Natural Hazards Review*, 4(3): 126-135.
- Hallegatte, S. et al., 2010. *Flood Risks, Climate Change Impacts and Adaptation Benefits in Mumbai*.

- Hernebring, C., 2006. 10års-regnets återkomst – förr och nu (Design storms in Sweden – then and now). VA-Forsk rapport nr 2006-04.
- Hjerpe, M., Glaas, E., 2012. Evolving local climate adaptation strategies: incorporating influences of socio-economic stress. *Mitig Adapt Strat GI*, 17(5): 471-486.
- IPCC, 2001. Climate change 2001: impacts, adaptation and vulnerability, Contribution of Working Group II to the Third Assessment Report of the Intergovernmental Panel on Climate Change, Cambridge University Press, Cambridge, UK, and New York, USA.
- Jansson, J., 2012. E-mail communication with Johan Jansson at City of Gothenburg.
- Liao, K.-H., 2012. A Theory on Urban Resilience to Floods—A Basis for Alternative Planning Practices. *Ecology and Society*, 17(4): 48.
- Ljunggren, O., 2013. E-mail communication with Olle Ljunggren at City of Gothenburg.
- MCGM, 2005. Greater Mumbai City Development Plan (2005–2025) [Online]. Mumbai: Mumbai Municipal Corporation. Available: <http://www.mcgm.gov.in> [Accessed 2013-04-25].
- Milly, P.C.D., Wetherald, R.T., Dunne, K.A., Delworth, T.L., 2002. Increasing risk of great floods in a changing climate. *Nature*, 415(6871): 514-517.
- Mooney, L.E., 1983. Applications and implications of fatality statistics to the flash flood problems, Proceedings of the 5th Conference on Hydrometeorology, Tulsa, USA.
- MSB, 2011. Identifiering av områden med betydande översvämningsrisk (Identification of areas with certain risk of flooding).
- OFDA/CRED, 2013. OFDA/CRED International Disaster Database.
- Rana, A., 2011. Avoiding natural disaster in megacities – Case study for Urban Drainage of Mumbai. *Vatten/ Journal of Water Management and Research*, 67: 55-59.
- Rana, A., Bengtsson, L., Olsson, J., Jothiprakash, V., 2013. Development of IDF-curves for tropical India by random cascade modeling. *Hydrol. Earth Syst. Sci. Discuss.*, 10(4): 4709-4738.
- Rana, A., Uvo, C., Bengtsson, L., Parth Sarthi, P., 2012. Trend analysis for rainfall in Delhi and Mumbai, India. *Clim Dynam*, 38(1): 45-56.
- SCB, 2012. Befolkningstäthet (invånare per kvadratkilometer) m.m efter region, kön, tabellinnehåll och tid (Population density etc.) [Online]. Available: www.scb.se [Accessed 2013-04-15].
- SCB, 2013a. Folkmängd i riket, län och kommuner 31 december 2012 och befolkningsförändringar 2012 (Population in the nation, regions and municipalities 31st of December 2012 and changes in population 2012) [Online]. Available: <http://www.scb.se> [Accessed 2013-03-22].
- SCB, 2013b. Statistisk årsbok för Sverige 2013 (Statistical Yearbook of Sweden 2013). 978-91-618-1571-5.
- SMHI, 2000. Översiktlig översvämningskartering längs Göta älv och Nordre älv (Overview flooding assessment along Göta River and Nordre River). Report no. 15.
- SMHI, 2005. Klimatunderlag för sårbarhetsanalys Göteborgs Stad (Climate background for vulnerability analysis of Gothenburg City).
- SMHI, 2008. Översiktlig översvämningskartering längs Mölndalsån (Overview flooding assessment along Mölndal River). Report no. 60.
- SMHI, 2010. Sveriges vattendrag (Rivers of Sweden).
- Stahre, P., 2008. Blue-green fingerprints in the city of Malmö, Sweden: Malmö's way towards a sustainable urban drainage. *Va syd*.
- WHO, 2002. Floods: climate change and adaptation strategies for human health, WHO (World Health Organization – Regional office for Europe).

Appended paper

VIII

Rana, A., Henonin, J., Bengtsson, L., and Mark, O. (2013) An Integrated modeling approach - Urban flooding inundation in Mumbai, CORFU, International Conference on Flood Resilience: Experiences in Asia and Europe, 5-7 September 2013, Exeter, United Kingdom.

URBAN FLOOD INUNDATION IN MUMBAI

Arun Rana^{1*}, Justine Hénonin², Lars Bengtsson¹ and Ole Mark²

¹ Lund University, Sweden; ²DHI Water & Environment, Denmark.

* Department of Water Resources Engineering, LTH, Lund University, Lund, Sweden 22100. Tel: + 46-2224487;
E-mail: Arun.Rana@tvrl.lth.se

ABSTRACT

Flooding on urban basins is intensifying due to rapid urbanization and is partially owed to climate change phenomena. Flooding primarily occurs because of drainage congestion of inland flow and/or over bank flow of rivers during severe rainfall events. Rapid urbanization is causing a major change in rainfall runoff relations and return the drainage system. The storm-water produced flood is one of the most severe and frequent natural disasters in the world, thus flood prevention and mitigation have become a challenge in both hydrology and hydraulics. In this paper we have established an integrated two-dimensional (2-D) hydrodynamic runoff model to simulate storm-water flooding processes in the metropolitan areas of Mumbai, India. We have run simulations with sample historical rainfall data from 1951-2004 to investigate flooding scenarios for the future. The rainfall events chosen were the extreme rainfall events in the data period. With rainfall and publicly available Digital Elevation Model (DEM) as input we simulated overland flow. The model results provide spatial flood risk information (e.g., water depth, inundation time and flow velocity during flooding), which can be then coupled with 1D model for real time flood forecasting and management of floods. The results suggest that flooding should be a major concern in the urban areas of the catchment. The natural terrain of the catchment is such that it enhances flood conditions in case of large rainfall events. Detailed flood maps with maximum water depth have been generated. The overall objective of the study is to provide an integrated planning and management tool to allow cost effective management for urban drainage systems with respect to changing rainfall patterns.

KEYWORDS

Drainage System, India, MIKE 21, Mumbai, Modelling, Urban Flooding

1. INTRODUCTION

Urban areas are flooded due to intense rain within the city, due to flooding from rivers or high sea level, or because of failure of the drainage system. However, In Urban context, flooding as result of heavy and short-term rainfall is most relevant. The distribution of rainfall in both space and time is extremely variable. Climate change is expected to modify the intensity and frequency of extreme rainfalls,(Frei et al. 1998;McKibben 2007). An increase in the intensity/frequency of extreme precipitation events may therefore result in increased flooding of urban areas (Ashley et al. 2005;Mailhot et al. 2007). Many researchers have described the possible impacts of climate change on urban drainage infrastructure and analysed the specific impacts on various urban areas, (Niemczynowicz 1989;Niemczynowicz 1999;Watt 2003;Denault et al. 2006;Grum et al. 2006;Guo 2006;Mailhot et al. 2007). Since the storm-water produced flood is one of the most severe and frequent natural disasters in the world, flood prevention and mitigation have a long history of study in both hydrology and hydraulics. Consequently, the study of flood mitigation is very important. High intensity and short duration precipitation associated with thunderstorms can generate the large volumes of surface runoff, which combined with flat terrain and low gradient drainage systems lead to severe urban flooding/flash flooding.

Urban areas, where impervious materials cover much of the land surface, are characterized by reduced infiltration and accelerated runoff cause floods that are unrelated to a floodplain. Historically, riverine flooding and flash flooding along floodplains have received considerable attention e.g., (Parker 1980). Much effort has gone into proper design and not much has been done on analysing the hydraulic conditions when flooding occurs in the urban setting. Societal and financial consequences of urban flooding are inevitably large as half of the global population resides in urban areas. With increasing population and build up of urban areas, the hydrological and hydraulic properties of these

areas are greatly changed, leading to increased flood hazard and damage, (Espey 1966). Complexities in the urban environment and drainage infrastructure have an inherent influence on surface runoff. This runoff generates urban flooding which poses challenges to modelling urban flood hazard and risk. Accurate simulation requires detailed elevation data. However, high-resolution elevation data is costly and commonly unavailable, hence only publicly available data sources e.g., US Geological Survey (USGS) Digital Elevation Models (DEM) and contour maps and ASTER data are typically relied on. The urban flood hazard and inherent complexities associated with drainage infrastructure have in the last two decades received attention (Djokic et al. 1991; Djordjevic et al. 1999; Hsu et al. 2000; Mark et al. 2004; Schmitt et al. 2004).

One-dimensional hydraulic methods have been used to study floods in river valleys for a long time. For example, HEC-RAS has been widely used to delineate the regulatory flood plain zone of 100-year or 500-year flood around a river, (Roberson 1998). Several 2-D hydraulic models were developed and used in shallow rivers and flood plains. Numerous studies on 2-D dam break models have been published e.g., (Chow 1973; Katopodes et al. 1997; Jha et al. 2000). However, the urban storm-water flood is different from dam breaking floods or river overflowing floods. It is usually caused by local high intensity rainfall and handicapped (e.g., low gradient) drainage systems. Besides using traditional hydrological methods as a primary tool, in recent years 2-D models have been employed to simulate some urban storm-water flood problems. Iwasa (1980) and Toda (2001) applied a 2-D numerical model for urban flood simulation in Japan. Cheng (2001) summarised the urban flood simulation techniques in China when a 2-D model was used to simulate the storm-water produced floods in the Great Tianjing City in northeast China.

Urban storm-water models such as SWMM, MOUSE/MIKE URBAN, Hydroworks/Infoworks or STORM are widely used to model urban drainage system e.g. (Balmforth D. 2006; Elliott et al. 2007). Such models provide a good representation of the physical phenomena but, because of their complexity, they are usually not user friendly and are generally limited to technical issues, (Balmforth D. 2006). Geographic Information Systems (GIS) are also commonly used to collect and manage the spatial data required as an input for models, (Heaney J.P. 2001). Currently there are only a few examples of such dedicated tools which use post processed data from GIS with ease, (Makropoulos et al. 2001). One such modelling tool that can use data pre-treated with GIS interface is MIKE 21.

In the present study we have used MIKE 21 as modelling platform for simulation of floods in the metropolitan areas of Mumbai. The objective of this paper is to estimate the flooding caused by large storms. In the present study, a 2D MIKE 21 hydrodynamic model is applied to urban parts of Mumbai, with intention to find out flooded areas after 1 day of rainfall simulation using historical rainfall events. Daily storms are disaggregated into storms with 10 min resolution and flow in the drainage pipes is not considered, as during intense rain periods almost all the runoff is as overland flow. The MIKE 21 simulation is performed on the largest storm events in the period 1951-2004. Flooding problem was highlighted by modelling studies performed by (Central water and power research station 2006) after 2005 year flood disaster. They used CHARISMA model for general purpose 1-D mathematical modelling for simulation of water movement in Mithi river catchment.

As indicated by Rana et al. (2012) that the rainfall intensity and frequency for Mumbai is related to certain global climate indices, it is of interest to study the effect of different rainfall intensities on flooding in the area for urban planning purposes. The average annual rainfall of Mumbai is about 2140 mm with monsoon rainfall contributing for 96% of the total annual rainfall (Rana et al. 2012). During this period, it usually rains during 0.5-2 hours and sometimes up to 4 hours uniformly over the city and severe flooding occurs in many parts of the city. The focus of the study is on metropolitan areas of Mumbai as part of modelling studies for flood simulation. The scope of study includes flooding mapping with different rainfall scenarios along with analysis of the water build up with 1-day simulation run with MIKE 21. The objective of the study is to provide an integrated planning and management tool to allow cost effective management for urban drainage systems with respect to changing rainfall patterns.

2. METHODOLOGY

2.1 Study Area

Mumbai ($18^{\circ}58'30''N$ $72^{\circ}49'33''E$) is located in south-western part of India. Mumbai is a cluster of seven islands. Mumbai is lined by the Arabian Sea on the western side, and also being intercepted by the Mahim, Mahul and Thane creeks, along with the Mithi, Dahisar, Poisar and Oshiwara rivers and their respective tributaries. A descriptive map of the Mumbai area is given in Figure 1 with areas in black boundary, which are used for the present modelling studies. A detailed description of drainage system in Mumbai has been provided by (Rana 2011). Note, that the tidal impacts are not considered in the modelling. Tidal impacts are important for Mumbai as they have great impact on outflow of water from the city and consequent water logging. The data for tidal fluctuations was not available and thus they were not considered.

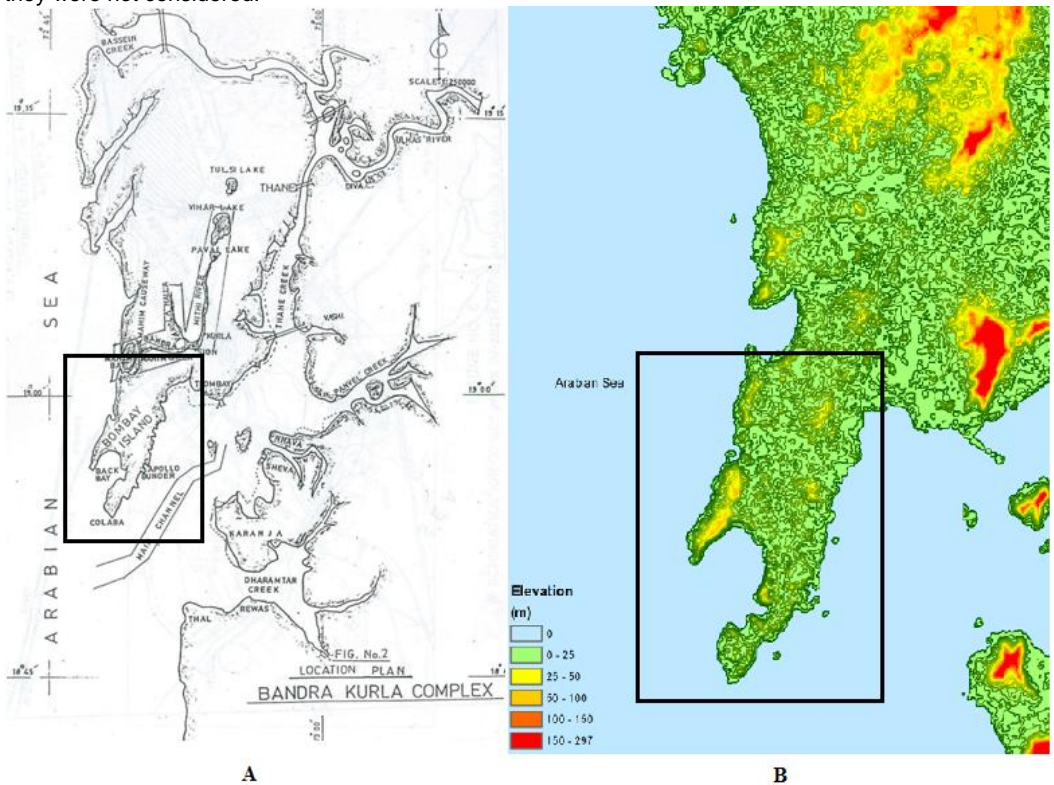

Figure 1: (a) Mumbai metropolitan area, Greater Mumbai, India, (Central water and power research station 2006)

(b) DEM of metropolitan areas of Mumbai indicating ground elevation in the study area

2.2 Rainfall Data

For this study, daily rainfall data was obtained from India Meteorological Department (IMD) for data period 1951-2004. Statistical analysis for extreme values was then performed to choose sample events for flood modelling; return level plot for extremes of precipitation is presented in Figure 2 (blue lines indicating the confidence interval of 90%). This was obtained from the observed period of data using statistical package R. It can be inferred from the Figure that 10 year return period for the dataset corresponds to 170mm of daily rainfall and density distribution of rainfall is mostly between 100 and 200mm of daily rain. The 8 largest storms were used for simulation of flooding in the area. A

representative rainfall from the threshold level was chosen at an interval to simulate different intensities of rainfall during the day. Statistics of chosen rainfall are represented in Table 1. It can be observed from the Table that the different events chosen are different in statistical properties they present during the day. The maximum rainfall intensity in table refers to maximum 10 min intensity observed during the event. A map of flooded areas during 26 June 2005 event (Fact finding committee 2005 floods) and areas designated as flood prone by (Municipal Corporation of Greater Mumbai 2005) were used for comparison of model results with observed flooding events.

The largest runoff intensities in most parts of the city are caused by short-term rainfall. Therefore the daily precipitation must be distributed over shorter time steps before being used as input in a runoff model. The stipulated data was in daily values and we needed finer time resolution values for flood modelling, thus the data was subjected to fractal disaggregation using random cascade disaggregation model (Rana et al. 2013). This daily-accumulated rainfall data for historical values was then processed with random cascade disaggregation model to get finer time scale values, from daily precipitation, of different durations to be used for modelling flood process. A sample representation of the disaggregated rainfall into finer time scale, which is used for model, is presented in Figure 3. Details of Cascade disaggregation can be obtained from (Rana et al. 2013).

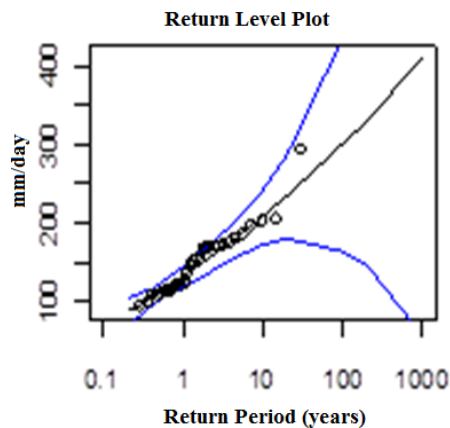

Figure 2: Return level plot for the extreme value statistics in data period with confidence interval of 90%

Table 1: Statistics of rainfall data chosen for flood modelling.

Rainfall Event (day)	Date	Maximum (mm/day)	Median (mm/day)	Mean (mm/day)	Root Mean Square (mm/day)	Standard deviation (mm/day)	Skewness
170mm	28/7/1979	1008	158	191	263	181	0.55
180mm	3/8/1976	1296	144	204	309	232	0.77
190mm	21/7/1996	2074	158	217	353	279	0.63
200mm	6/9/1991	1166	194	227	325	232	0.43
220mm	10/7/1958	1224	209	261	362	251	0.62
240mm	18/6/1953	3758	166	271	487	405	0.78
260mm	3/7/1974	1080	238	292	395	266	0.61
290mm	26/6/2002	2909	245	328	512	393	0.64

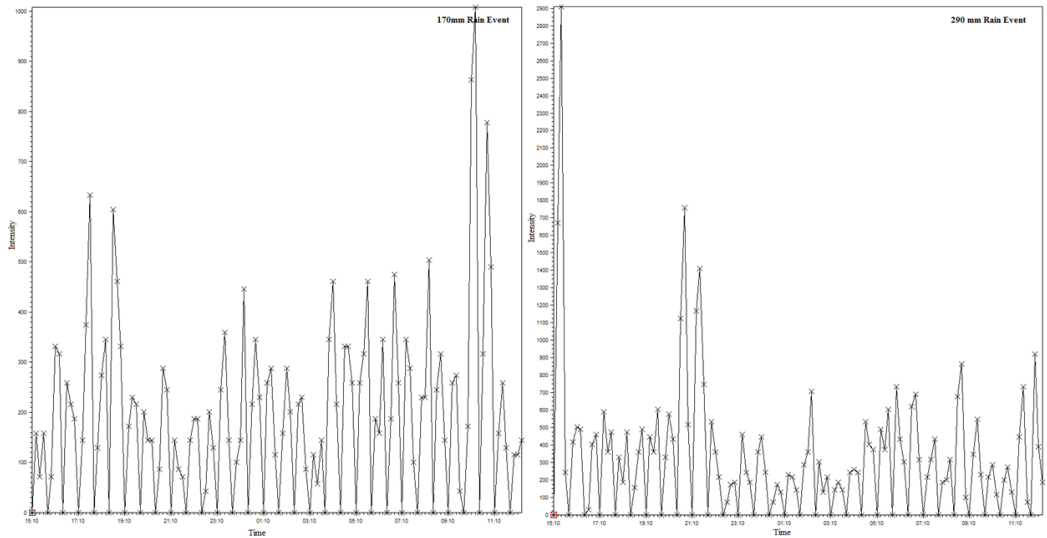

Figure 3: Representation of rainfall data for 170mm and 290 mm rain event respectively in to fine temporal resolution used in the model. (Intensity of rainfall is converted from 5 min to mm/day)

2.3 Topographic Information

A 25m-grid resolution DEM is obtained from ASTER Project (<http://www.ersdac.or.jp/GDEM/E/1.html>) for setting up the flood model. DEM is the digital elevation model of the area indication surface elevation at each grid point (Figure1). The ASTER Global Digital Elevation Model (ASTER GDEM) is a joint product developed and made available to the public by the Ministry of Economy, Trade, and Industry (METI) of Japan and the United States National Aeronautics and Space Administration (NASA). It is generated from data collected from the Advanced Space borne Thermal Emission and Reflection Radiometer (ASTER), a space borne earth observing optical instrument. The ASTER GDEM is the only DEM that covers the entire land surface of the Earth at high resolution. It is widely used in geographical information studies across the world. The DEM data for study area is processed at 25m resolutions for filling up of missing values in the area using ARCGIS, which then in turn is used for preparation of bathymetry of the study area.

2.4 MIKE 21

2.4.1 MIKE 21 Basics

MIKE 21 (2011) was used for the computation of water levels and water flows. In MIKE 21 HD (Hydrodynamic module) the momentum equations are integrated over depth to get the shallow water equations in two directions. The rotation of earth and wind stress on the water surface can be accounted for, but these effects are minor in the urban overland flow. Manning equation is used for determining the bottom friction of the overland flow. A constant manning number is used in the present approach due to lack of information of land-use/land-cover in the study area. MIKE 21 HD makes use of Alternating Direction Implicit (ADI) technique to integrate the equations for mass and momentum conservation in the space and time. The equations in xy direction for every grid (rectangular and regular) are resolved by Double Sweep (DS) algorithm, where it alternates between x and y direction for solution of equations. The model as such has zero mass and momentum falsification and negligible numerical energy falsification but that might not be the case in the present study due to use of drying and flooding depth of 0.002 and 0.003 respectively. For further details on the methodology readers are suggested to read "MIKE 21 scientific documentation (2011)". The hydrodynamic model in the MIKE 21 Flow Model (MIKE 21 HD) is a general numerical modelling system for the simulation of water depths and flows in estuaries, bays, coastal areas and land surfaces. In the model we have vertically

integrated momentum equations, effect of the rotation of the Earth and the effect of the wind stress on water depth.

2.4.2 MIKE 21 Model building

Firstly rainfall data for all the 8 scenarios was used to build a MIKE 21 dfs0 file which is time series file with equal number of time steps and rainfall was provided as mm/hr. Then ASTER DEM data was processed using ArcGIS and converted to ASCII format to be read by MIKE 21. This ASCII files were then imported to MIKE grid files (dfs2) to be used as bathymetry file for the model using MIKE ZERO toolbox. This MIKE 21 grid file is now processed DEM, which is to be used as 2-D surface model. MIKE 21 dfs2 file is then supplied with all the eight different rainfall for 24-hour time period simulation. The rainfall data used for modelling had 10min time step. Statistical analysis of different time series was also performed for all scenarios so that modelling results can also be compared in respect to data choice from the entire period. Boundary conditions in the model are programme detected and follow the natural course.

All the model simulations were made with same input of DEM and different rainfall for 1 day and output results were saved every minute. The simulations started with a dry surface with drying and flooding depth of 0.002 and 0.003m respectively. Drying depth is minimum water depth allowed in a point before it is taken out from the calculations whereas flooding depth is the depth at which the point is re-entered into the calculations. Different parameters were calculated for the whole area including maximum height of water depth, time of maximum height, maximum flux, time at maximum flux, H water depth, U velocity and V velocity. We would compare maximum height of floodwater and flux during the simulation event along with water balance for all the scenario runs.

3. RESULTS AND DISCUSSION

3.1 Model Comparison

There is limited information available about the historically flooded areas in Mumbai. The model results are thus compared using publicly available flood map (Fact finding committee 2005 floods) and areas designated as flood prone by (Municipal Corporation of Greater Mumbai 2005) in a 2005 report (Figure 4). The 290mm rain event (21 hours) was used to compute a maximum flood map, which was then compared to the Fact Finding Committee 2005 flood map as well as to the designated flood prone areas from MCGM. The 290mm rain scenario is the most intense among the modelled scenario and as such it is the closest rain event to the 26 July 2005 event. The rain event applied for the modelling has an accumulated total rainfall of 290mm, with a maximum intensity of 120.8mm/hr. The total amount of rainfall for 2005 event was 944mm during 1 day with maximum intensity of 190mm/hr. coinciding with a maximum high tide of 4.48m during the same day. These are observed values from Colaba station in Mumbai. The 26 July 2005 year event in Mumbai has been classified as very heavy (more than 200mm/day as per the criteria for rainfall classification of Indian Metrological Department) and the return period of that rain event was more than 100 years. Figure 5 shows a map comparing the modelled flooded areas to the 2005 flooded areas and the designated flood zones. It can be inferred most of the areas, which are historically flooded, are also simulated as flooded in the modelling results. Further, it should be noted that the model has predicted some areas with flooding more than 1m where flooding was not reported by the Fact Finding Committee for the 2005 flood. One reason for such difference may be related to the resolution of data used in the model. We have used 30m digital elevation model (DEM) public data in the present study while information about the data source resolution and processing method for compared maps is unavailable. The source DEM data used for modelling is rough and only for bare ground, information about the urban infrastructures is missing which could provide better information on flooding, which is hindrance for accurate reproduction of the flow through the city. The maps presented in earlier studies are not providing information on the depth of water accumulated in the flooded areas thus no comparison with simulated water depths could be made. Moreover the model shows less extended flood in some areas as the 290mm scenario includes less rain than the one observed during the 2005 flood event. However, no drainage network influence was included in the model, since such information was not available. So

the model is also expected to overestimate the flood to a certain extent, as a small part of the rain will be drainage, before surface flooding begins.

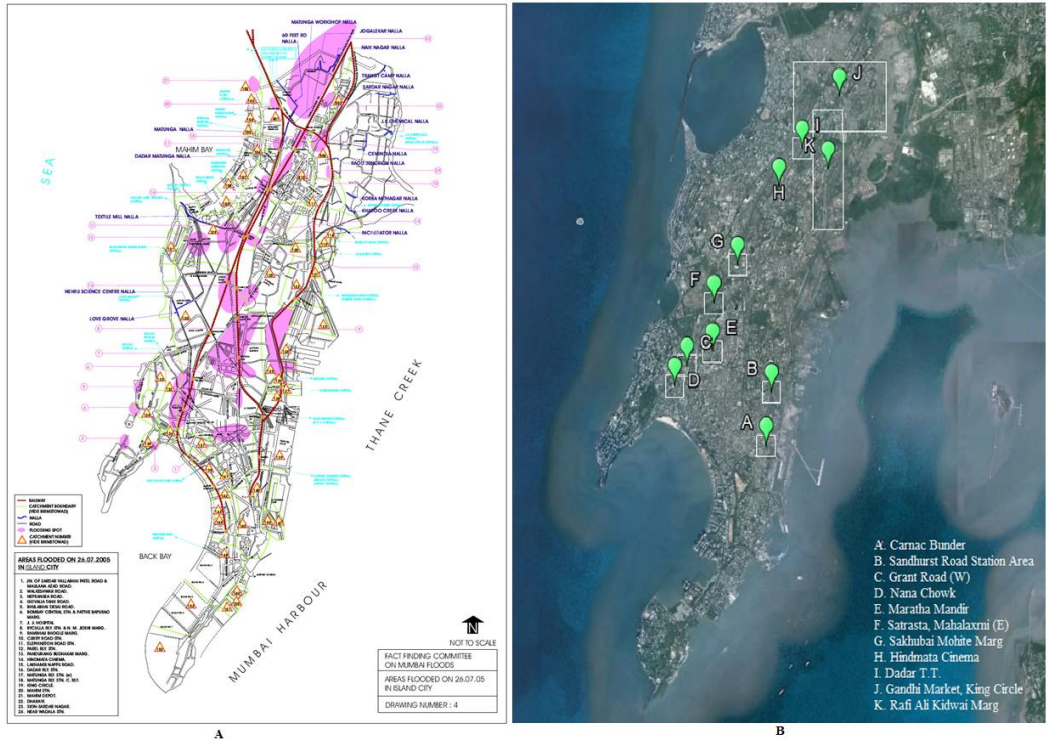

Figure 4: A- Flooded areas as depicted by fact finding committee for 2005 year flood, B- Flood prone areas as outlined by Municipal Corporation of Greater Mumbai

3.2 Model Results

The present, study presented similar results in 2D flood maps compared to a CHARISMA model study conducted by (Central water and power research station 2006). The CHARISMA model results can be seen in Figure 5, most of the areas presented in the study are accumulated clusters where flooding generally occurs during rainy season. The output from the simulations is water depth and velocities all over the urban area. Figure 5 represents the maximum water depth attained in study area for different rainfall scenario simulations. Red colour in all the Figures signifies maximum water depth above 1m in study area after 1 day of model run, which in turn tells about the havoc it creates considering the population of the city. It can be easily observed from the Figure that there is flooding in each and every part of city. It was also visually observed by the authors by a site visit and using Google Earth, that there are very few infiltration surfaces in the city and the poor natural drainage of the city doesn't help much for the cause of runoff water. The natural topography and location of the area does not help to evacuate the surface runoff (flat area by the sea, outlet of a river, reclaimed land, and swamp, whatever natural cause that made the area of Mumbai a natural floodplain). If we consider the different scenario results we would understand the flooding in the areas is directly related to amount and intensity of rainfall received in the area. The flood levels are evenly increasing in all the rainfall scenarios and are occurring in the same areas, owing to usage of same DEM for calculations. The scenarios thus depend on selection of data for simulation run and its intensity. So eventually it would be on selection of rainfall data from different scenarios, but the model can be used for prediction of real time flood events if supplied with real time rainfall data and which would eventually help in planning and management of the city. It is clearly evident that there are large areas under constant threat of flooding in study area. The results for built up of water height and flux can also be presented

in real-time as the model processes the rainfall and other parameters which can then intern be used for emergency procedures. Computational statistics and water balance for model run are presented in Table 2 and Table 3 respectively for all the scenario runs. It can be noted from Table 2 that the maximum water depth in each scenario is reaching a maximum above 5m, which is typically in the depressions of the city and localised ponds developed during rainy season. The observations in Table 2 are computed water depths at various locations by 1-day scenario run. The IDF curves for the city with typical return level intensity of rainfall has been computed and presented by (Rana et al. 2013) and same can be used by the authorities for design of new drainage systems and other infrastructure projects.

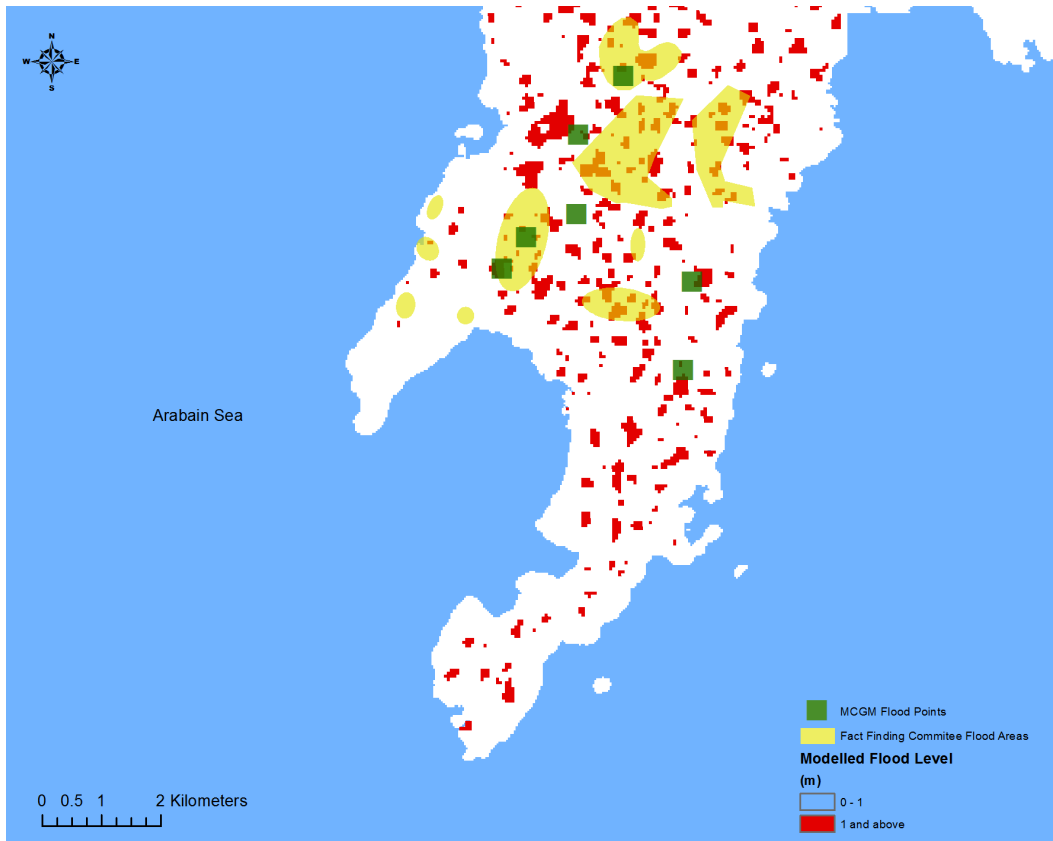

Figure 5: Comparative flood map of the study area with modelled flooded areas and those presented in earlier studies.

It can be observed from Figure 5 that flooded area is much similar for all the rain events. The difference between the event simulations could have been bigger if a higher resolution could have been used runoff process calculation would be expected more precise. The model has predicted almost same areas to be flooded when given an input for rainfall in each simulation with only difference from rain process that can be clearly seen from Table 2. The study had various limitations in terms of data. A close look on DEM of Mumbai used in study reveals that there is almost flat gradient so the water builds up very much. Moreover there are several areas in city, which are below the mean sea level, which are prone to severe flooding in case of combination of high tides and rainfall event (this was precisely the case during July 2005 event). Considering these results it would be desirable if the municipal corporation considers development of digital map for drains in the city and finer

resolution DEM, so that studies could be more accurate way. There is need of rehabilitation and displacement of people living in slums near these big drains as all the wastewater produced is unaccounted for. There is need of imparting civic sense and knowledge dispersion about better management practices among people. The drains must be cleaned on regular basis so that they can work in full capacity until new are designed (current drains are inadequate for capacity). There should be no interconnection of storm water and sewerage networks for efficient functioning. In order to reduce the flooding in the city the municipal corporation should consider a good artificial drainage system for the city, including pumping systems in order to remove the frequent water logging problems in Mumbai. The drainage systems of the city are very old and under-designed for capacity. This is also highlighted in details by (Rana et al. 2012) and (Rana 2011).

The results of study can also be integrated in geographical reference using simple tools like ArcGIS and Google earth for better understanding of the areas under threat and real time flood monitoring. Results of this study can be improved if we can be provided with high quality of data, which has been a limitation for this study. We would take pipe drainage network into account, by estimation of its capacity (volume), which can be removed from the rain applied on the 2D model, or by development of 1D model. Further a MIKE 11 model of Mithi River is currently developed and calibrated at IIT Mumbai. We could couple it with MIKE 21 model for further analysis of flood processes in Mumbai better assessment of flooding on a finer resolution of time and space and real time rainfall data can be incorporated for real time forecasting of floods in the city.

Table 2: Computational statistics of all simulations in 1 day model run

Rainfall Event	Maximum Water depth (m)
170mm	5.19
180mm	5.26
190mm	5.46
200mm	5.52
220mm	5.84
240mm	5.84
260mm	6.08
290mm	6.17

Table 3: Water Balance for all the four simulation in 1-day model run (values in m³)

Rainfall Event	Hydrology processes	B: Final volume in model area *			Total	C: Total inflow **	E: Continuity balance = B-A-C+D ***
		Water depth correction	Volume in wet area	Volume in dry area			
170mm	63783858	26	63858858	420	63859278	63783884	0.09
180mm	66988130	36	67063418	142	67063560	66988166	0.08
190mm	72642728	96	72717527	691	72718219	72642824	0.05
200mm	75469397	199	75544482	509	75544992	75469597	0.09
220mm	86741523	144	86816698	364	86817062	86741667	0.09
240mm	87759350	216	87834817	144	87834961	87759566	0.03
260mm	96157999	324	96233181	536	96233717	96158323	0.15
290mm	109435307	870	109511249	323	109511573	109436178	0.06

* Final volume in model area (B) from inflow sources and open boundaries inflow is 0 m³ for all events

** Total Inflow (C) from outflow sinks and open boundaries is 0 m³ for all events

***Initial Volume (A) is constant at 75394.52 m³ and total outflow (D) is 0 m³ for all rain events

4. CONCLUSION

In the present study, a 2D MIKE 21 hydrodynamic model was successfully applied to urban areas in part of Mumbai, the purpose was to find out flooded areas after 1 day of rainfall simulation using historical rainfall events were used. Comparison of modelled flood areas with the observations sheds light on the key aspects of flood modelling in the area including need for need and information for such a study. The maps presented in earlier studies are not providing information on key criteria's; such as spatial and temporal extent, flooding depth etc.; that can be compared with the present model. The presented model is able to cover all the areas (spatially) as presented/observed by other studies but the extent of flooding is less than the observations owing to lack of information and bare DEM without any urban infrastructure. The study has revealed that there are parts in the city, which are under huge threat of flooding when it rains owing to heavy rainfall events, flat gradient and impervious surfaces. The problem with flooding can be expected to increase due to rapid expansion of the city and depletion of pervious surfaces. The water depth in all the simulations under consideration is reaching height of more than 1m in each case and goes up to 6m of water for the most severe rainfall event. The results of present study can be used by municipal authorities to focus on area, which are under instantaneous and serious stress of flooding, for better management practices. Further a 1D model can be coupled with these results for holistic view on the scenario and real time rainfall data can be supplied for real time forecasting, Hénonin et. al, (2012).

5. REFERENCES

- Ashley, R. M., D. J. Balmforth, A. J. Saul and J. D. Blanksby. (2005). Flooding in the future - predicting climate change, risks and responses in urban areas. *Water Science and Technology*, 52(5), 265-273.
- Balmforth D., D. C. J., Butler D., Shaffer P. (2006). Integrated Urban Drainage Pilots: Scoping Study. London, DEFRA.
- Central water and power research station. (2006). 1-D mathematical model and desk studies for mitigating floods of Mithi river in Mumbai, Technical report no. 4297. Mumbai, Ministry of water resources, Govt. of India.
- Cheng, X. T. a. Q., J.W. (2001). Development of Urban Flood Simulation Techniques in China. In: Theme C, Forecasting and Mitigation of Water-Related Disasters. XXIX International Association of Hydraulic Research Congress Proceedings, Tsinghua University Press.
- Chow, V. T. a. B., A.Z. (1973). Hydrodynamic Modeling of Two- Dimensional Watershed Flow. *Journal of Hydraulics Division. ASCE*, 99(11), 2023-2040.
- Denault, C., R. G. Millar and B. J. Lence. (2006). ASSESSMENT OF POSSIBLE IMPACTS OF CLIMATE CHANGE IN AN URBAN CATCHMENT1. *JAWRA Journal of the American Water Resources Association*, 42(3), 685-697.
- Djokic, D. and D. R. Maidment. (1991). Terrain analysis for urban stormwater modelling. *Hydrological Processes*, 5(1), 115-124.
- Djordjevic, S., D. Prodanovic and C. Maksimovic. (1999). An approach to simulation of dual drainage. *Water Science and Technology*, 39(9), 95-103.
- Elliott, A. H. and S. A. Trowsdale. (2007). A review of models for low impact urban stormwater drainage. *Environmental Modelling & Software*, 22(3), 394-405.
- Espey, W. H., Jr., C.W. Morgan, and F.D. Masch,. (1966). A Study of Some Effects of Urbanization on Storm Runoff From a Small Watershed. Report No. 3. Austin, Texas, Texas Water Development Board.
- Frei, C., C. Schär, D. Lüthi and H. C. Davies. (1998). Heavy precipitation processes in a warmer climate. *Geophysical Research Letters*, 25(9), 1431-1434.

- Grum, M., A. T. Jorgensen, R. M. Johansen and J. J. Linde. (2006). The effect of climate change on urban drainage: an evaluation based on regional climates model simulations. *Water Science and Technology*, 54(6-7), 9-15.
- Guo, Y. P. (2006). Updating rainfall IDF relationships to maintain urban drainage design standards. *Journal of Hydrologic Engineering*, 11(5), 506-509.
- Heaney J.P., S. D., Wright L. (2001). Geographical Information Systems, Decision Support Systems, and Urban Management, US Environmental Protection Agency.
- Hénonin, J., Russo, B., Mark, O., Gourbesville, P., 2012, Real-time urban flood forecasting and modelling - a state of the art. *Journal of Hydroinformatics*. Accepted.
- Hsu, M. H., S. H. Chen and T. J. Chang. (2000). Inundation simulation for urban drainage basin with storm sewer system. *Journal of Hydrology*, 234(1-2), 21-37.
- Iwasa, Y. a. K. I. (1980). Numerical Method for Inundating Flood. Kyoto, Japan, Annuals of Disasters Prevention Research Institute of Kyoto University, No.23, B-2.
- Jha, A. K., J. Akiyama and M. Ura. (2000). Flux-difference splitting schemes for 2D flood flows. *Journal of Hydraulic Engineering-Asce*, 126(1), 33-42.
- Katopodes, N. and T. Strelkoff. (1997). Computing two-dimensional dam-break flood waves (vol 104, pg 1267, 1978). *Journal of Hydraulic Engineering-Asce*, 123(10), 938-938.
- Mailhot, A., S. Duchesne, D. Caya and G. Talbot. (2007). Assessment of future change in intensity-duration-frequency (IDF) curves for southern Quebec using the Canadian regional climate model (CRCM). *Journal of Hydrology*, 347(1-2), 197-210.
- Makropoulos, C., D. Butler and C. Maksimovic. (2001). Gis-supported stormwater source control implementation and urban flood risk mitigation. *Advances in Urban Stormwater and Agricultural Runoff Source Controls*, 6, 95-105.
- Mark, O., S. Weesakul, C. Apirumanekul, S. B. Aroonnet and S. Djordjevic. (2004). Potential and limitations of 1D modelling of urban flooding. *Journal of Hydrology*, 299(3-4), 284-299.
- McKibben, B. (2007). Climate change 2007: The physical science basis: Summary for policymakers (vol 54, pg 44, 2007). *New York Review of Books*, 54(8), 58-58.
- MIKE 21. (2011). Scientific documentation on MIKE 21 flow model – Hydrodynamic Module. Copenhagen, Denmark, DHI.
- Municipal Corporation of Greater Mumbai. (2005). "Greater Mumbai City Development Plan (2005 to 2025)." Retrieved 25 March, 2013, from <http://www.mcgm.gov.in/iri/portal/anonymous?NavigationTarget=navurl://095e1c7b9486b1423b881dce8b106978>.
- Niemczynowicz, J. (1989). Impact of the Greenhouse-Effect on Sewerage Systems - Lund Case-Study. *Hydrological Sciences Journal-Journal Des Sciences Hydrologiques*, 34(6), 651-666.
- Niemczynowicz, J. (1999). Urban hydrology and water management - present and future challenges. *Urban Water*, 1(1), 1-14.
- Parker, D. (1980). Floods - a Geographical Perspective - Ward,R. *Geography*, 65(287), 156-156.
- Rana, A. (2011). Avoiding natural disaster in megacities – Case study for Urban Drainage of Mumbai. *Vatten/ Journal of Water Management and Research*, 67, 55-59.
- Rana, A., L. Bengtsson, J. Olsson and V. Jothiprakash. (2013). Development of IDF-curves for tropical india by random cascade modeling. *Hydrol. Earth Syst. Sci. Discuss.*, 10(4), 4709-4738.
- Rana, A., C. Uvo, L. Bengtsson and P. Parth Sarthi. (2012). Trend analysis for rainfall in Delhi and Mumbai, India. *Climate Dynamics*, 38(1), 45-56.
- Roberson, J. A., J.J. Cassidy, and M.H. Chaudhry. (1998). *Hydraulic Engineering* (2nd edition). New York, John Wiley and Sons, Inc.
- Schmitt, T. G., M. Thomas and N. Etrich. (2004). Analysis and modeling of flooding in urban drainage systems. *Journal of Hydrology*, 299(3-4), 300-311.
- Toda K., K. I., K. Kuriyama, and O. Maeda. (2001). Inundation Flow Analysis in Urban Areas Considering Streets and Underground Space Effects. In: Theme C. Forecasting and Mitigation of Water-Related Disasters. XXXIX International Association of Hydraulic Research Congress Proceedings, Beijing, China, Tsinghua University Press.
- Watt, W. E., Waters, D., and McLean, R. (2003). Climate change and urban stormwater infrastructure in Canada: Context and case studies. Waterloo, Ontario, Meteorological Service of Canada.

