



LUND UNIVERSITY

Transient waves in non-stationary media

Åberg, Ingegerd; Kristensson, Gerhard; Wall, David

1994

[Link to publication](#)

Citation for published version (APA):

Åberg, I., Kristensson, G., & Wall, D. (1994). *Transient waves in non-stationary media*. (Technical Report LUTEDX/(TEAT-7037)/1-27/(1994)). [Publisher information missing].

Total number of authors:

3

General rights

Unless other specific re-use rights are stated the following general rights apply:

Copyright and moral rights for the publications made accessible in the public portal are retained by the authors and/or other copyright owners and it is a condition of accessing publications that users recognise and abide by the legal requirements associated with these rights.

- Users may download and print one copy of any publication from the public portal for the purpose of private study or research.
- You may not further distribute the material or use it for any profit-making activity or commercial gain
- You may freely distribute the URL identifying the publication in the public portal

Read more about Creative commons licenses: <https://creativecommons.org/licenses/>

Take down policy

If you believe that this document breaches copyright please contact us providing details, and we will remove access to the work immediately and investigate your claim.

LUND UNIVERSITY

PO Box 117
221 00 Lund
+46 46-222 00 00

CODEN:LUTEDX/(TEAT-7037)/1-27/(1994)

Revision No. 1: July 1995

Transient waves in non-stationary media

Ingegerd Åberg, Gerhard Kristensson and David J. N. Wall

Department of Electrosience
Electromagnetic Theory
Lund Institute of Technology
Sweden

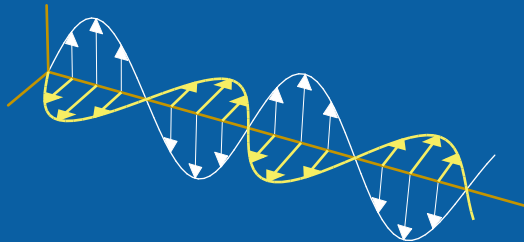

Ingegerd Åberg, Gerhard Kristensson
Department of Electromagnetic Theory
Lund Institute of Technology
P.O. Box 118
SE-221 00 Lund
Sweden

David J. N. Wall
Department of Mathematics
University of Canterbury
Christchurch 1
New Zealand

Abstract

This paper treats propagation of transient waves in non-stationary media, which has many applications in e.g. electromagnetics and acoustics. The underlying hyperbolic equation is a general, homogeneous, linear, first order 2×2 system of equations. The coefficients in this system depend only on one spatial coordinate and time. Furthermore, memory effects are modeled by integral kernels, which, in addition to the spatial dependence, are functions of two different time coordinates. These integrals generalize the convolution integrals, frequently used as a model for memory effects in the medium. Specifically, the scattering problem for this system of equations is addressed. This problem is solved by a generalization of the wave splitting concept, originally developed for wave propagation in media which are invariant under time translations, and by an imbedding or a Green functions technique. More explicitly, the imbedding equation for the reflection kernel and the Green functions (propagator kernels) equations are derived. Special attention is paid to the problem of non-stationary characteristics. A few numerical examples illustrate this problem.

1 Introduction and basic system of equations

In a recent paper [1], a new method of analyzing wave propagation in non-stationary or time-varying media was suggested. This method is an extension of the well-established methods of wave splitting, invariant imbedding and Green functions techniques, see Refs. [3, 5, 6, 12, 16, 17] and [7]. Wave propagation in non-stationary media has also been investigated with other methods, see, e.g. Refs. [13–15].

Non-stationary media are characterized by material parameters that are changing with time. Relevant examples are found in, e.g. telecommunication problems, such as fading and modulation problems, and in problems concerning moving media. The analysis of the wave propagation phenomena in linear, non-stationary media also serves as an indispensable tool for analyzing wave propagation in non-linear media by means of linearization.

The investigation of wave propagation problems in non-stationary media leads to hyperbolic partial differential equations (PDE) with coefficients varying both in time and space. The purpose of this paper is to systematically investigate the wave propagation problem in a general non-stationary medium. This paper presents the theory of our techniques, subsequent papers will develop numerical solutions to pertinent problems.

Investigations of wave propagation, some of which are mentioned in Section 2 below, suggest a generalized form of the dynamics of the wave fields. In the present work, the parameters of the medium are assumed to vary in one spatial direction, here taken to the z -direction, and time t . The basic equation is the following first

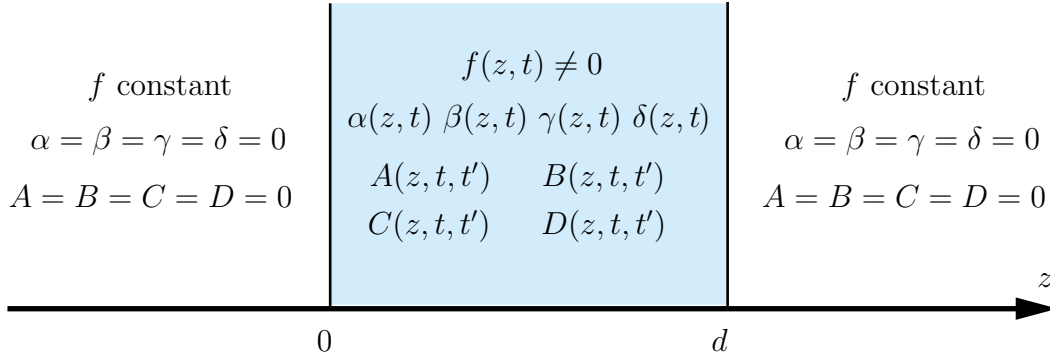

Figure 1: Geometry of the problem.

order 2×2 system of equations:

$$\begin{aligned} \frac{\partial}{\partial z} \begin{pmatrix} u^+(z, t) \\ u^-(z, t) \end{pmatrix} = & f(z, t) \begin{pmatrix} -1 & 0 \\ 0 & 1 \end{pmatrix} \frac{\partial}{\partial t} \begin{pmatrix} u^+(z, t) \\ u^-(z, t) \end{pmatrix} + \begin{pmatrix} \alpha(z, t) & \beta(z, t) \\ \gamma(z, t) & \delta(z, t) \end{pmatrix} \begin{pmatrix} u^+(z, t) \\ u^-(z, t) \end{pmatrix} \\ & + \int_{-\infty}^t \begin{pmatrix} A(z, t, t') & B(z, t, t') \\ C(z, t, t') & D(z, t, t') \end{pmatrix} \begin{pmatrix} u^+(z, t') \\ u^-(z, t') \end{pmatrix} dt' \end{aligned} \quad (1.1)$$

The reason for the \pm superscript is described in the subsequent sections. The slowness function $f(z, t)$ is a notation for

$$f(z, t) = \frac{1}{c(z, t)} > 0$$

where $c(z, t)$ is the wave (phase) velocity. In order to model also non-stationary memory effects, integral terms have been included in the equation. These memory effects are non-local in time. In the integrals, the variable t describes the current time, whereas the variable t' is an integral measure, relating to the starting time of the excitation, see also Appendix B. The system (1.1) is therefore a strictly hyperbolic system.

The positive function $f(z, t)$ is a continuous, bounded function of the variables z and t everywhere. Furthermore, it is assumed to be constant outside the slab $(0, d)$

$$\begin{cases} f(z, t) = 1/c_0 & , z < 0 \\ f(z, t) = 1/c_d & , z > d \end{cases} \quad (1.2)$$

and continuously differentiable, with bounded derivatives, in z and t everywhere inside the slab, i.e. $(z, t) \in (0, d) \times (-\infty, \infty)$, see also Figure 1. This implies that $f(0, t) = 1/c_0$ and $f(d, t) = 1/c_d$ for all times t .

The functions $\alpha(z, t)$, $\beta(z, t)$, $\gamma(z, t)$ and $\delta(z, t)$ are equal to zero outside the slab and they are continuous, bounded functions inside the slab (not necessarily continuous at the edges of the slab).

The functions $A(z, t, t')$, $B(z, t, t')$, $C(z, t, t')$ and $D(z, t, t')$ are always zero outside of the slab $(0, d)$. Due to causality, they vanish identically inside the slab

provided $t < t'$. For simplicity, the functions $A(z, t, t')$, $B(z, t, t')$, $C(z, t, t')$ and $D(z, t, t')$ are assumed continuous and bounded as functions of the variables z , t and t' in the region $t > t'$, $0 < z < d$.

The assumptions described above can, of course, be relaxed and the results presented in this paper then hold for a larger class of parameters. However, the purpose of this paper is not to formulate the results for the weakest set of assumptions possible, but to exploit the potential of the method for a set of physically reasonable assumptions.

In the scattering application addressed in this paper, the incident wave is assumed to impinge normally on a slab. Two different scattering problems can be identified. In the direct scattering problem, the material parameters are known and the goal is to calculate the response of a known incoming field. On the other hand, the inverse problem assumes knowledge of the incident and the scattered field (data collected exterior to the medium) and the problem is to infer information about the material parameters. Both these problems can be investigated by the methods presented in this paper. However, the main pertinence of the method is in connection with applications to the direct scattering problem. Some aspects of the non-stationary inverse scattering problem were analyzed in Ref [1].

After this introductory section, a few explicit examples of applications are given in Section 2. The analysis of the non-stationary characteristic curves is found in Section 3. The imbedding equation for the reflection kernel is derived in Section 4, and the Green functions (propagator kernels) equations are derived in Section 5. Some explicit simplifications and concluding remarks are given in Section 6 and Section 7, respectively. Three appendices contain some technical mathematical details and some numerical illustrations of characteristic traces.

2 Examples

This section contains a few examples of general interest to the formulation presented in this paper. The underlying equations of the fields in all these examples are the Maxwell equations.

$$\begin{cases} \nabla \times \mathbf{E}(\mathbf{r}, t) = -\frac{\partial \mathbf{B}}{\partial t}(\mathbf{r}, t) \\ \nabla \times \mathbf{H}(\mathbf{r}, t) = \frac{\partial \mathbf{D}}{\partial t}(\mathbf{r}, t) \end{cases}$$

Here, $\mathbf{E}(\mathbf{r}, t)$ and $\mathbf{H}(\mathbf{r}, t)$ are the electric and the magnetic fields, respectively, and $\mathbf{B}(\mathbf{r}, t)$ the magnetic induction and $\mathbf{D}(\mathbf{r}, t)$ the electric displacement field. All fields are assumed to be quiescent before a fixed time. This property guarantees that all fields vanish at $t \rightarrow -\infty$.

2.1 Electromagnetic waves in inhomogeneous and dispersive media

To model wave propagation in a non-stationary, inhomogeneous, and dispersive medium, the following constitutive relations are relevant [1]:

$$\begin{cases} \mathbf{D}(\mathbf{r}, t) = \epsilon_0 \left(\epsilon(z) \mathbf{E}(\mathbf{r}, t) + \int_{-\infty}^t \chi_e(z, t, t') \mathbf{E}(\mathbf{r}, t') dt' \right) \\ \mathbf{B}(\mathbf{r}, t) = \mu_0 \mathbf{H}(\mathbf{r}, t) \end{cases}$$

Here $\epsilon_0 \epsilon(z) > 0$ is the permittivity of the medium, and μ_0 the permeability of vacuum. The non-stationary dispersive effects are modeled by the susceptibility kernel $\chi_e(z, t, t')$.

The vector wave propagation problem is reduced to a scalar problem by assuming that the electric field is transverse to the stratification of the medium, and, furthermore, depends only on the coordinates (z, t) . The dynamics of the fields is cast into the form of (1.1) by the following non-unique wave splitting [6]:

$$\begin{pmatrix} u^+(z, t) \\ u^-(z, t) \end{pmatrix} = \frac{1}{2} \begin{pmatrix} 1 & -\frac{c_0}{\sqrt{\epsilon(z)}} \partial_t^{-1} \\ 1 & \frac{c_0}{\sqrt{\epsilon(z)}} \partial_t^{-1} \end{pmatrix} \begin{pmatrix} E(z, t) \\ \partial_z E(z, t) \end{pmatrix}$$

where the anti-derivative ∂_t^{-1} is defined as

$$\partial_t^{-1} g(t) = \int_{-\infty}^t g(t') dt'$$

The coefficients of the dynamics, (1.1), in this example are

$$\begin{cases} f(z, t) = \sqrt{\epsilon(z)}/c_0 \\ \alpha(z, t) = -\gamma(z, t) = -\frac{1}{4} \frac{d}{dz} \ln \epsilon(z) - \frac{1}{2c_0 \sqrt{\epsilon(z)}} \chi_e(z, t, t')|_{t'=t} \\ \beta(z, t) = -\delta(z, t) = \frac{1}{4} \frac{d}{dz} \ln \epsilon(z) - \frac{1}{2c_0 \sqrt{\epsilon(z)}} \chi_e(z, t, t')|_{t'=t} \\ A(z, t, t') = B(z, t, t') = -C(z, t, t') = -D(z, t, t') = -\frac{1}{2c_0 \sqrt{\epsilon(z)}} \frac{\partial \chi_e}{\partial t}(z, t, t') \end{cases}$$

Note that the regularity assumptions made on the susceptibility kernel $\chi_e(z, t, t')$ in Ref [1] (continuously differentiable in $z \in (0, L)$ and t' , and twice continuously differentiable in $t, t \geq t'$) are stronger than needed to meet the assumptions made on the functions $A(z, t, t')$, $B(z, t, t')$, $C(z, t, t')$ and $D(z, t, t')$ in Section 1, and are not needed if the splitting is made from Maxwell's equations directly, see Section 2.3.

2.2 A generalized wave equation

An obvious extension of the results presented in Ref [1] concerning propagation of electromagnetic waves in inhomogeneous and time-varying media is to allow the

permittivity $\epsilon_0\epsilon$ to vary in time as well as in space. The relevant constitutive relations in this example are

$$\begin{cases} \mathbf{D}(\mathbf{r}, t) = \epsilon_0\epsilon(z, t)\mathbf{E}(\mathbf{r}, t) \\ \mathbf{B}(\mathbf{r}, t) = \mu_0\mathbf{H}(\mathbf{r}, t) \end{cases}$$

where the relative permittivity $\epsilon(z, t) > 0$. This is a model of an inhomogeneous, non-dispersive, non-stationary medium. For the sake of simplicity, the dispersive memory terms in Section 2.1 are omitted. However, the more complex model, where these memory terms are included, is straightforward to analyze.

With the usual assumption of an electric field \mathbf{E} that is transverse to the z -axis and that depends on z and t only, the wave equation is

$$\frac{\partial^2 \mathbf{E}}{\partial z^2}(z, t) - \frac{\partial^2 (f^2 \mathbf{E})}{\partial t^2}(z, t) = 0 \quad (2.1)$$

where

$$f(z, t) = \sqrt{\mu_0\epsilon_0\epsilon(z, t)}$$

This equation is a special case of a more generalized wave equation

$$\begin{aligned} \frac{\partial^2 u}{\partial z^2}(z, t) - \frac{\partial^2 (f^2 u)}{\partial t^2}(z, t) \\ + \mathcal{A}(z, t) \frac{\partial u}{\partial z}(z, t) + \mathcal{B}(z, t) \frac{\partial u}{\partial t}(z, t) + \mathcal{C}(z, t) u(z, t) = 0 \end{aligned} \quad (2.2)$$

which also has applications in, e.g. linear acoustics in media where the propagation conditions change rapidly with time.

In order to see how equation (2.2) is related to the general hyperbolic wave equation (1.1), the concept of wave splitting is introduced. The wave splitting can be defined in several different ways. The definition adopted here renders a very simple u^\pm -dynamics for the wave equation in (2.1). Thus, proceeding formally, the wave splitting is defined by the following transformation of the dependent variables:

$$\begin{pmatrix} u^+(z, t) \\ u^-(z, t) \end{pmatrix} = \frac{1}{2} \begin{pmatrix} 1 & -\frac{1}{f(z, t)} \partial_t^{-1} \\ 1 & \frac{1}{f(z, t)} \partial_t^{-1} \end{pmatrix} \begin{pmatrix} u(z, t) \\ u_z(z, t) \end{pmatrix}$$

which generalizes the wave splitting introduced in Ref [6]. The new fields $u^\pm(z, t)$ satisfy a first order 2×2 system of hyperbolic partial differential equations, which is identical to the generalized u^\pm -dynamics in (1.1). The explicit expressions of the coefficients are

$$\begin{cases} \alpha(z, t) = -\frac{1}{2} \frac{\partial}{\partial z} \ln f(z, t) - \frac{3}{2} \frac{\partial f}{\partial t}(z, t) - \frac{1}{2} \mathcal{A}(z, t) + \frac{1}{2} \frac{\mathcal{B}(z, t)}{f(z, t)} \\ \beta(z, t) = +\frac{1}{2} \frac{\partial}{\partial z} \ln f(z, t) - \frac{1}{2} \frac{\partial f}{\partial t}(z, t) + \frac{1}{2} \mathcal{A}(z, t) + \frac{1}{2} \frac{\mathcal{B}(z, t)}{f(z, t)} \\ \gamma(z, t) = +\frac{1}{2} \frac{\partial}{\partial z} \ln f(z, t) + \frac{1}{2} \frac{\partial f}{\partial t}(z, t) + \frac{1}{2} \mathcal{A}(z, t) - \frac{1}{2} \frac{\mathcal{B}(z, t)}{f(z, t)} \\ \delta(z, t) = -\frac{1}{2} \frac{\partial}{\partial z} \ln f(z, t) + \frac{3}{2} \frac{\partial f}{\partial t}(z, t) - \frac{1}{2} \mathcal{A}(z, t) - \frac{1}{2} \frac{\mathcal{B}(z, t)}{f(z, t)} \end{cases}$$

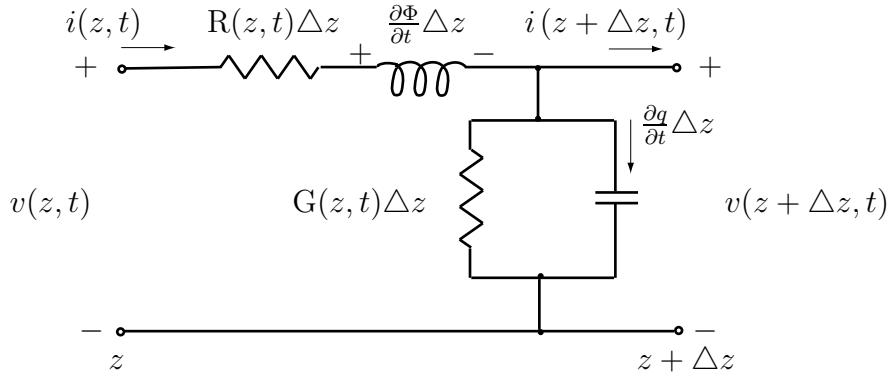

Figure 2: Transmission line model.

and

$$\begin{cases} A(z, t, t') = \frac{1}{2} \frac{1}{f(z, t)} \left[f(z, t') \frac{\partial \mathcal{A}}{\partial t'}(z, t') - \frac{\partial \mathcal{B}}{\partial t'}(z, t') + \mathcal{C}(z, t') \right] \\ B(z, t, t') = \frac{1}{2} \frac{1}{f(z, t)} \left[-f(z, t') \frac{\partial \mathcal{A}}{\partial t'}(z, t') - \frac{\partial \mathcal{B}}{\partial t'}(z, t') + \mathcal{C}(z, t') \right] \\ C(z, t, t') = -A(z, t, t') \\ D(z, t, t') = -B(z, t, t') \end{cases}$$

2.3 Wave propagation on the transmission line

In this example, propagation of current-voltage waves on a transmission line is considered. The material of the transmission line, i.e. the conductors together with the insulation, may vary in time as well as in space. In this model, memory effects are permitted.

The equivalent circuit segment model of Figure 2 provides the basis of the derivation of the general transmission line equations. Here, $R(z, t)$ and $G(z, t)$ are the series resistance and the shunt conductance per unit length of the transmission line, respectively. The series inductance and the shunt capacitance per unit length, which are denoted $L(z, t)$ and $C(z, t)$, respectively, are both assumed positive and finite. The voltage $v(z, t)$ and the current $i(z, t)$ are related, respectively, to the magnetic flux $\Phi(z, t)$ and the charge $q(z, t)$ through

$$\begin{cases} \Phi(z, t) = L(z, t)i(z, t) + \int_{-\infty}^t \chi_m(z, t, t')i(z, t') dt' \\ q(z, t) = C(z, t)v(z, t) + \int_{-\infty}^t \chi_e(z, t, t')v(z, t') dt' \end{cases}$$

The magnetic flux, $\Phi(z, t)$, and the electric charge, $q(z, t)$, depend on the current $i(z, t)$ and the voltage $v(z, t)$ at time t , respectively. In addition to these multiplicative terms, Φ and q are connected to the previous values of the currents and voltages of the transmission line. The memory functions are modeled by the two

Transmission line		Maxwell's equations	
Parameter	Symbol	Parameter	Symbol
Inductance	$L(z, t)$	Magnetic permeability	$\mu(z, t)$
Capacitance	$C(z, t)$	Electric permittivity	$\epsilon(z, t)$
Series resistance	$R(z, t)$	Magnetic conductivity	$\sigma_m(z, t)$
Shunt resistance	$G(z, t)$	Electric conductivity	$\sigma_e(z, t)$
Inductive susceptibility	$\chi_m(z, t, t')$	Magnetic susceptibility	$\chi_m(z, t, t')$
Capacitive susceptibility	$\chi_e(z, t, t')$	Electric susceptibility	$\chi_e(z, t, t')$

Table 2: Correspondence between the parameter symbols used and the material properties relevant in the two main applicable problems.

integral terms with the kernel functions $\chi_m(z, t, t')$ describing the inductive susceptibility and $\chi_e(z, t, t')$ modeling the capacitive susceptibility. Simplifications occur in a material that is invariant under time translations. In this case, the susceptibility kernels are functions of the difference argument $t - t'$ rather than of t and t' . A comparison between the pertinent parameter symbols used in this transmission line application and the material properties of Section 2.1 is found in Table 2.

The Kirchhoff current and voltage relations are now applied to the circuit mesh of Figure 2. In the limit $\Delta z \rightarrow 0$, the two general transmission line equations are obtained. They are represented in the following matrix form:

$$\begin{pmatrix} 0 & C(z, t) \\ L(z, t) & 0 \end{pmatrix} \frac{\partial}{\partial t} \begin{pmatrix} i(z, t) \\ v(z, t) \end{pmatrix} + \frac{\partial}{\partial z} \begin{pmatrix} i(z, t) \\ v(z, t) \end{pmatrix} = B \begin{pmatrix} i(z, t) \\ v(z, t) \end{pmatrix} \quad (2.3)$$

where the operator matrix B is given by

$$B = \begin{pmatrix} 0 & -G(z, t) - \frac{\partial C}{\partial t}(z, t) - \frac{\partial}{\partial t} \int_{-\infty}^t \chi_e(z, t, t') \bullet dt' \\ -R(z, t) - \frac{\partial L}{\partial t}(z, t) - \frac{\partial}{\partial t} \int_{-\infty}^t \chi_m(z, t, t') \bullet dt' & 0 \end{pmatrix}$$

where the symbol \bullet denotes the place holder for the operand.

This system of equations is easily transformed into the general first order 2×2 system of hyperbolic equations, (1.1). The following wave splitting diagonalizes the system (2.3):

$$\begin{pmatrix} u^+(z, t) \\ u^-(z, t) \end{pmatrix} = \frac{1}{2} \begin{pmatrix} 1 & \sqrt{\frac{C(z, t)}{L(z, t)}} \\ 1 & -\sqrt{\frac{C(z, t)}{L(z, t)}} \end{pmatrix} \begin{pmatrix} i(z, t) \\ v(z, t) \end{pmatrix} \quad (2.4)$$

The explicit expressions of the coefficients are:

$$\left\{ \begin{array}{l} f(z, t) = \sqrt{L(z, t)C(z, t)} \\ \alpha(z, t) = \frac{1}{2}[+h_1(z, t) + h_2(z, t) - h_3(z, t) - h_4(z, t)] \\ \beta(z, t) = \frac{1}{2}[-h_1(z, t) - h_2(z, t) + h_3(z, t) - h_4(z, t)] \\ \gamma(z, t) = \frac{1}{2}[+h_1(z, t) - h_2(z, t) - h_3(z, t) + h_4(z, t)] \\ \delta(z, t) = \frac{1}{2}[-h_1(z, t) + h_2(z, t) + h_3(z, t) + h_4(z, t)] \end{array} \right. \quad (2.5)$$

and

$$\left\{ \begin{array}{l} A(z, t, t') = -\frac{1}{2} \left[\frac{\partial \chi_e}{\partial t}(z, t, t') \sqrt{\frac{L(z, t')}{C(z, t')}} + \sqrt{\frac{C(z, t')}{L(z, t)}} \frac{\partial \chi_m}{\partial t}(z, t, t') \right] \\ B(z, t, t') = \frac{1}{2} \left[\frac{\partial \chi_e}{\partial t}(z, t, t') \sqrt{\frac{L(z, t')}{C(z, t')}} - \sqrt{\frac{C(z, t')}{L(z, t)}} \frac{\partial \chi_m}{\partial t}(z, t, t') \right] \\ C(z, t, t') = -B(z, t, t') \\ D(z, t, t') = -A(z, t, t') \end{array} \right. \quad (2.6)$$

where the functions $h_1(z, t)$, $h_2(z, t)$, $h_3(z, t)$ and $h_4(z, t)$ are given by

$$\left\{ \begin{array}{l} h_1(z, t) = \frac{1}{2} \sqrt{L(z, t)C(z, t)} \frac{\partial}{\partial t} \ln \frac{C(z, t)}{L(z, t)} \\ h_2(z, t) = \frac{1}{2} \frac{\partial}{\partial z} \ln \frac{C(z, t)}{L(z, t)} \\ h_3(z, t) = \sqrt{\frac{L(z, t)}{C(z, t)}} \left[G(z, t) + \frac{\partial C}{\partial t}(z, t) + \chi_e(z, t, t')|_{t'=t} \right] \\ h_4(z, t) = \sqrt{\frac{C(z, t)}{L(z, t)}} \left[R(z, t) + \frac{\partial L}{\partial t}(z, t) + \chi_m(z, t, t')|_{t'=t} \right] \end{array} \right.$$

The regularity requirements of the coefficients stated in Section 1 are met if $R(z, t)$ and $G(z, t)$ are continuous functions, and $C(z, t)$ and $L(z, t)$ continuously differentiable in both z and t . Moreover, the functions $\chi_e(z, t, t')$ and $\chi_m(z, t, t')$ are assumed continuous in z and t' and continuously differentiable in t .

The next two sections contain the main equations for the solution of the scattering problem in inhomogeneous, non-stationary, dispersive media. Specifically, the imbedding equation and the Green functions equations are derived.

3 Characteristic curves

One of the major differences between the treatment of the problems in this paper and earlier work is that the characteristics of equation (1.1) are non-stationary in

time. This complicates many of the formulae when compared to those applicable to media which admit time translation symmetries. When the slowness is independent of time but the dynamics is non-stationary, there is still a lack of invariance under time translation due to lower-order terms. In this case some simplifications can be made. This is evidenced by comparing the imbedding equation (4.2) of Section 4, the Green functions equations (5.3) and (5.4) of Section 5, and equations (4.3), (5.2) and (5.3) of Ref [1].

In Ref [1], as the slowness was *not* a function of time, it was quite easy to make a transformation into travel time coordinates to straighten the characteristic curves. In the more general situation considered here, such a transformation is more difficult to perform and implies that a problem of almost the same complexity as the original problem has to be solved. No transformation to straighten the characteristic curves is therefore made in this paper. Thus, the examination of the properties of the characteristic traces of (1.1) is appropriate. In Appendix A some of the properties of the transformation to straighten the characteristic curves are outlined.

The characteristic traces for the u^+ -equation satisfy

$$\frac{d\tau^+}{d\zeta} = f(\zeta, \tau^+(\zeta)) \quad (3.1)$$

with an initial condition (the curve passes through the point (z, t))

$$\tau^+(z) = t \quad (3.2)$$

The superscript plus has been used on the characteristic with positive slope; traces with negative slope appear in later sections and will have superscript minus.

The existence of a unique, locally defined, solution of the initial value problem in (3.1) and (3.2) is guaranteed by the assumption of f in Section 1 [4, 9]. To emphasize the dependence of the initial conditions, the solution is written in the form

$$\tau^+ = \tau^+(\zeta; z, t) \quad (3.3)$$

where $(\zeta, \tau^+(\zeta; z, t))$ describes a curve in \mathbb{R}^2 passing through (z, t) and ζ being a parameter.

Figure 3 shows the system of coordinates (ζ, τ^+) . The position of the physical slab coincides with the interval $(0, d)$ of the ζ -axis. The assumptions of the slowness f ensure that a locally defined flow has been defined [2]. Maximal extension of this flow up to any point, at which it becomes undefined, is ensured. This is a property that depends purely of the slowness f . This flow forms a group with respect to the parameter ζ and as such it has a unique inverse and unit element. For the purposes of this paper, the form of the solution formally represented by equation (3.3) suffices. The inverse elements are:

$$\tau^+(\zeta; z, \tau^+(z; \zeta, t)) = t, \quad \tau^+(z; \zeta, \tau^+(\zeta; z, t)) = t$$

and the unit element can be written as

$$\tau^+(z; z, t) = t$$

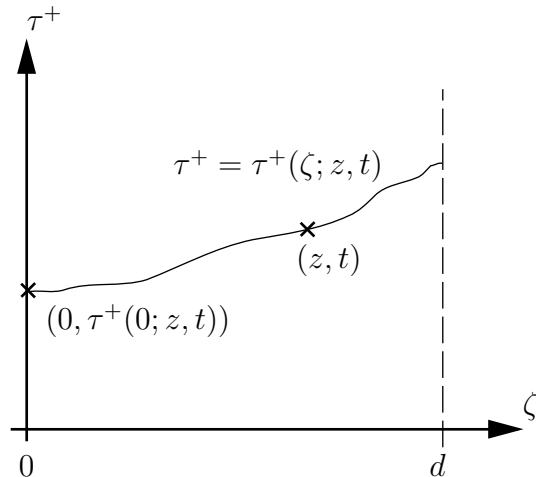

Figure 3: The characteristic of the u^+ -equation.

One other formula obtained from elementary calculus that is needed in the sequel is

$$\frac{\partial \tau^+}{\partial t}(\zeta; z, t)|_{t=\tau^+(z; \zeta, t)} = \left(\frac{\partial \tau^+}{\partial t}(z; \zeta, t) \right)^{-1}$$

or its dual

$$\frac{\partial \tau^+}{\partial t}(z; \zeta, t)|_{t=\tau^+(\zeta; z, t)} = \left(\frac{\partial \tau^+}{\partial t}(\zeta; z, t) \right)^{-1}$$

In this paper, of particular importance is the case of $\zeta = 0$.

From the presumptions of the function $f(z, t)$ given in Section 1 and from equation (3.1), it is clear, that the derivative $\frac{d\tau^+}{d\zeta}$ is a continuous function in ζ . Furthermore, these presumptions also guarantee that the partial derivatives $\frac{\partial \tau^+}{\partial z}$ and $\frac{\partial \tau^+}{\partial t}$ exist [9].

Also note, that if (z, t) is a point on the characteristic curve, so is $(\zeta', \tau^+(\zeta'; z, t))$. Thus $\tau^+ = \tau^+(\zeta; z, t)$ and $\tau^+ = \tau^+(\zeta; \zeta', \tau^+(\zeta'; z, t))$ are two equivalent representations of the same characteristic curve.

Integration of equation (3.1) along the characteristic yields an expression for the function τ^+ :

$$\tau^+(\zeta_2; z, t) - \tau^+(\zeta_1; z, t) = \int_{\zeta_1}^{\zeta_2} f(\zeta', \tau^+(\zeta'; z, t)) d\zeta' \quad (3.4)$$

which specifies the time needed for the u^+ -wave to move from position ζ_1 to position ζ_2 along the characteristic passing through (z, t) .

An additional relation for the u^+ -characteristics, needed for the derivations in Section 5, is now derived. In (3.4), let $\zeta_2 = \zeta$ and $\zeta_1 = z$, and differentiate the equation with respect to z and t . This shows that the function

$$\phi(\zeta; z, t) = \frac{\partial \tau^+}{\partial z}(\zeta; z, t) + f(z, t) \frac{\partial \tau^+}{\partial t}(\zeta; z, t)$$

is a solution to the uniquely solvable homogeneous Volterra equation of the second kind

$$\phi(\zeta; z, t) + \int_{\zeta}^z \frac{\partial f}{\partial \tau^+}(\zeta', \tau^+(\zeta'; z, t)) \phi(\zeta'; z, t) d\zeta' = 0$$

which therefore must only have the trivial solution. Thus, the following identity holds:

$$\frac{\partial \tau^+}{\partial z}(\zeta; z, t) + f(z, t) \frac{\partial \tau^+}{\partial t}(\zeta; z, t) = 0 \quad (3.5)$$

The interpretation of this conservation equation states the obvious result that as (z, t) varies along one particular characteristic trace, for fixed ζ , τ^+ is invariant. Another more simple proof of (3.5) is to use the fact that $\tau^+ = \tau^+(\zeta; z, t)$ and $\tau^+ = \tau^+(\zeta; \zeta', \tau^+(\zeta'; z, t))$ are two equivalent representations of the same characteristic curve. Differentiation wrt ζ' then gives the identity (3.5).

Some explicit examples of characteristic curves are found in Appendix C.

4 Imbedding equation

The two split fields, $u^{\pm}(z, t)$, introduced in a previous section, are interrelated. This is because when the wave propagates through a medium, in which the properties are changing, the u^{\pm} -waves are related through a scattering operator. This operator is represented by a time integral, which can be derived from Duhamel's integral, see Appendix B. The result is

$$u^-(z, t) = \int_{-\infty}^t R(z, t, t') u^+(z, t') dt' \quad (4.1)$$

Here, the kernel $R(z, t, t')$, which is the reflection kernel of a subsection (z, d) of the total slab $(0, d)$, is identical to the one used in Ref [1]. By causality, $R(z, t, t') = 0$, $t < t'$.

The reflection kernel, $R(z, t, t')$, satisfies a partial differential equation, which describes the variation in $R(z, t, t')$ as the coordinates z , t and t' vary. This equation, the imbedding equation, is derived by differentiating (4.1) and the use of the dynamics (1.1). This operation yields the imbedding equation for the reflection kernel $R(z, t, t')$, valid in the domain $0 < z < d$, $t > t'$.

$$\begin{aligned} \frac{\partial R}{\partial z}(z, t, t') - f(z, t) \frac{\partial R}{\partial t}(z, t, t') + \frac{\partial R}{\partial t'}(z, t, t') f(z, t') &= C(z, t, t') \\ + \delta(z, t) R(z, t, t') + R(z, t, t') \left[-\frac{\partial f(z, t')}{\partial t'} - \alpha(z, t') \right] \\ - \int_{t'}^t R(z, t, t'') \beta(z, t'') R(z, t'', t') dt'' & \\ - \int_{t'}^t R(z, t, t'') A(z, t'', t') dt'' + \int_{t'}^t D(z, t, t'') R(z, t'', t') dt'' & \\ - \int_{t'}^t \left\{ \int_{t'}^{t''} R(z, t, t''') B(z, t'', t''') R(z, t''', t') dt''' \right\} dt'' & \end{aligned} \quad (4.2)$$

The initial condition of the reflection kernel $R(z, t, t')$ is

$$R(z, t, t')|_{t'=t} = -\frac{1}{2} \frac{\gamma(z, t)}{f(z, t)} \quad (4.3)$$

and the boundary condition at $z = d, t > t'$ is

$$R(d, t, t') = 0$$

The Cauchy problem of the imbedding equation, (4.2), with data specified on the plane parameterized by $\mathbf{r} = (z, t, t)$, see (4.3), is well-posed. This is a consequence of the non-vanishing functional determinant [10, p. 26]

$$J = \begin{vmatrix} 1 & 0 & 0 \\ 0 & 1 & 1 \\ 1 & -f(z, t) & f(z, t) \end{vmatrix} = 2f(z, t) \neq 0$$

The functional differential equation for the reflection kernel $R(z, t, t')$ can be solved numerically given the material parameters. This implies that the solution to the direct scattering problem, i.e. the determination of the reflected fields, can be computed through (4.1). The inverse problem, i.e. the determination of the material parameters, given the reflection kernel $R(z, t, t')$, can also be approached through (4.2). This problem will be addressed in another paper.

4.1 Discontinuity of the reflection kernel

The solution of the imbedding equation, $R(z, t, t')$, is continuous everywhere except across the surface $t' = h(z, t)$, where $R(z, t, t')$ has a possible jump discontinuity. This finite jump discontinuity is introduced by the possible jump discontinuity in $\gamma(z, t)$ at $z = d$, i.e. if $\gamma(d^-, t) = \lim_{z \rightarrow d-0} \gamma(z, t) \neq 0$, see (4.3). The normal to the surface $t' = h(z, t)$, i.e. $(h_z, h_t, -1)$ satisfies the characteristic equation

$$\frac{\partial h}{\partial z}(z, t) - f(z, t) \frac{\partial h}{\partial t}(z, t) = f(z, h(z, t))$$

and, due to (4.3), the surface contains the line $\mathbf{r} = (d, t, t)$, i.e. $t = h(d, t)$.

The vector field describing the characteristic traces is $(1, -f(z, t), f(z, t'))$ and it lies on a hyper-surface. The projection of this vector field onto the (z, t) -plane is described by

$$\frac{d\tau^-}{d\zeta} = -f(\zeta, \tau^-(\zeta)) \quad (4.4)$$

so that this curve, on planes $t'=\text{constant}$, has representation $(\zeta, \tau^-(\zeta; z, t), t')$. To emphasize the dependence of the initial conditions, the solution to (4.4) has been written in the form

$$\tau^- = \tau^-(\zeta; z, t)$$

Similarly, the projection of the vector field onto the (z, t') -plane is described by equation (3.1) and this curve on planes $t=\text{constant}$ has representation $(\zeta, t, \tau^+(\zeta; z, t'))$.

All curves of interest here, will originate from the line $\mathbf{r} = (d, t, t)$, so that a characteristic trace, Γ , emanating from this line has parametric form

$$\Gamma : \quad \mathbf{r}(z, t) = (z, \tau^-(z; d, t), \tau^+(z; d, t))$$

As mentioned previously, the R kernel has a possible initial jump discontinuity on the (d, t, t) -line, in the direction of increasing t , of size

$$[R]_{\Gamma(z=d)} = \frac{1}{2} \frac{\gamma(d, t)}{f(d, t)} \quad (4.5)$$

The bracket notation used here, denotes the finite jump discontinuity of the reflection kernel R , with respect to positive t -direction. This discontinuity propagates along the characteristic as

$$\left. \frac{d[R]}{dz} \right|_{\Gamma} = \left(\delta(z, \tau^-(z; d, t)) - \frac{\partial f}{\partial t'}(z, t')|_{t'=\tau^+(z; d, t)} - \alpha(z, \tau^+(z; d, t)) \right) [R]_{\Gamma}$$

which upon integrating from d to z , and with use of (4.5), yields

$$[R]_{\Gamma} = \frac{1}{2} \frac{\gamma(d, t)}{f(d, t)} \exp \left\{ \int_d^z \left(\delta(z', \tau^-(z'; d, t)) - \frac{\partial f}{\partial t'}(z', t')|_{t'=\tau^+(z'; d, t)} - \alpha(z', \tau^+(z'; d, t)) \right) dz' \right\}$$

5 Green functions

The relationship between the split fields u^{\pm} in Section 4 was evaluated at a specific z -value and the reflection kernel $R(z, t, t')$ was interpreted as the reflection kernel for a subslab (z, d) of the physical slab $(0, d)$. This interpretation was performed by the use of an imbedding argument.

In contrast to the analysis presented in the previous section, this section contains an analysis of the relationship between the exterior excitation $u^+(0, t)$ and the internal fields $u^{\pm}(z, t)$ of the physical slab $(0, d)$. The operator that maps the excitation $u^+(0, d)$ to the internal fields $u^{\pm}(z, t)$ has an integral representation. This representation leads to the definition of the Green functions $G^{\pm}(z, t, t')$ of the propagation problem.

From Duhamel's integral, see Appendix B, an explicit mapping of the excitation $u^+(0, t)$ to the internal fields $u^{\pm}(z, t)$ can be obtained. For convenience this mapping is evaluated at two different times. The basic difference between the two definitions in Eqs. (5.1) and (5.2), is that in (5.1), the time coordinate t is evaluated at the field position z , while in (5.2), it is evaluated at the left end point of the slab, $z = 0$. Both of them are needed to derive the equations in this section. The expressions $\tau^+(0; z, t)$ and $\tau^+(z; 0, t)$ denote specific points along the relevant characteristics of

the wave front, see Section 3. The expressions are

$$\begin{cases} u^+(z, t) = u^+(0, \tau^+(0; z, t))p(z, \tau^+(0; z, t)) \\ \quad + \int_{-\infty}^{\tau^+(0; z, t)} G^+(z, \tau^+(0; z, t), t')p(z, t')u^+(0, t') dt' \\ u^-(z, t) = \int_{-\infty}^{\tau^+(0; z, t)} G^-(z, \tau^+(0; z, t), t')p(z, t')u^+(0, t') dt' \end{cases} \quad (5.1)$$

or evaluated at time $\tau^+(z; 0, t)$ (use the fact that $\tau^+(0; z, \tau^+(z; 0, t)) = t$)

$$\begin{cases} u^+(z, \tau^+(z; 0, t)) = u^+(0, t)p(z, t) + \int_{-\infty}^t G^+(z, t, t')p(z, t')u^+(0, t') dt' \\ u^-(z, \tau^+(z; 0, t)) = \int_{-\infty}^t G^-(z, t, t')p(z, t')u^+(0, t') dt' \end{cases} \quad (5.2)$$

where the attenuation factor is defined as

$$p(z, t) = \exp \left\{ \int_0^z \alpha(\zeta, \tau^+(\zeta; 0, t)) d\zeta \right\}$$

In this formula, the integration of the function α is performed along the characteristics of the first equation in (1.1), see Section 3 for more details on characteristic curves in non-stationary media and Appendix B for details on the propagation of finite jump discontinuities along characteristic curves. By causality, the Green functions $G^\pm(z, t, t') = 0$ for $t' > t$.

The Green functions equations are derived by performing the calculation of

$$\frac{\partial}{\partial z} \begin{pmatrix} u^+ \\ u^- \end{pmatrix}$$

in two different ways. The first way is obtained through explicit differentiation of the definition of the Green functions in (5.2), and the second way is obtained by using the general dynamics, (1.1). In both cases repeated use of the definition of the Green functions, (5.2), and the general dynamics, (1.1), is necessary. The comparison between these two expressions leads to the following Green functions equations, $0 < z < d$, $t > t'$:

$$\begin{aligned} & \frac{\partial G^+}{\partial z}(z, t, t') - \alpha(z, \tau^+(z; 0, t))G^+(z, t, t') + G^+(z, t, t')\alpha(z, \tau^+(z; 0, t')) \\ & - \beta(z, \tau^+(z; 0, t))G^-(z, t, t') - A(z, \tau^+(z; 0, t), \tau^+(z; 0, t')) \frac{\partial \tau^+}{\partial t'}(z, 0, t') \\ & - \int_{t'}^t A(z, \tau^+(z; 0, t), \tau^+(z; 0, t'')) \frac{\partial \tau^+}{\partial t''}(z, 0, t'')G^+(z, t'', t') dt'' \\ & - \int_{t'}^t B(z, \tau^+(z; 0, t), \tau^+(z; 0, t'')) \frac{\partial \tau^+}{\partial t''}(z, 0, t'')G^-(z, t'', t') dt'' = 0 \end{aligned} \quad (5.3)$$

and

$$\begin{aligned}
& \frac{\partial G^-}{\partial z}(z, t, t') - 2f(z, \tau^+(z; 0, t)) \left(\frac{\partial \tau^+}{\partial t}(z; 0, t) \right)^{-1} \frac{\partial G^-}{\partial t}(z, t, t') \\
& - \delta(z, \tau^+(z; 0, t)) G^-(z, t, t') + G^-(z, t, t') \alpha(z, \tau^+(z; 0, t')) \\
& - \gamma(z, \tau^+(z; 0, t)) G^+(z, t, t') - C(z, \tau^+(z; 0, t), \tau^+(z; 0, t')) \frac{\partial \tau^+}{\partial t'}(z; 0, t') \quad (5.4) \\
& - \int_{t'}^t C(z, \tau^+(z; 0, t), \tau^+(z; 0, t'')) \frac{\partial \tau^+}{\partial t''}(z; 0, t'') G^+(z, t'', t') dt'' \\
& - \int_{t'}^t D(z, \tau^+(z; 0, t), \tau^+(z; 0, t'')) \frac{\partial \tau^+}{\partial t''}(z; 0, t'') G^-(z, t'', t') dt'' = 0
\end{aligned}$$

with the initial condition

$$G^-(z, t, t')|_{t'=t} = -\frac{1}{2} \frac{\gamma(z, \tau^+(z; 0, t))}{f(z, \tau^+(z; 0, t))} \frac{\partial \tau^+}{\partial t}(z; 0, t) \quad (5.5)$$

The initial condition on $G^+(z, t, t')|_{t'=t}$ is obtained by integrating (5.3), i.e.

$$\begin{aligned}
G^+(z, t, t')|_{t'=t} = & -\frac{1}{2} \int_0^z \left[\frac{\beta(z', \tau^+(z'; 0, t)) \gamma(z', \tau^+(z'; 0, t))}{f(z', \tau^+(z'; 0, t))} \right. \\
& \left. - 2A(z', \tau^+(z'; 0, t), \tau^+(z'; 0, t)) \right] \frac{\partial \tau^+}{\partial t}(z'; 0, t) dz' \quad (5.6)
\end{aligned}$$

These differential equations for the Green functions generalize those given in, e.g. Refs. [1, 11, 12]. Note that the Green functions $G^\pm(z, t, t') = 0$ for $t' > t$.

From the definition of the Green functions $G^\pm(z, t, t')$, (5.2), and the definition of the reflection kernel $R(z, t, t')$, (4.1), at $z = 0$, the following boundary conditions of G^\pm at $z = 0$ and $z = d$ are obtained for all times:

$$\begin{cases} G^+(0, t, t') = 0 \\ G^-(d, t, t') = 0 \\ G^-(0, t, t') = R(0, t, t') \end{cases}$$

The last boundary condition is a special case of a more general interrelationship between the Green functions $G^\pm(z, t, t')$ and the reflection kernel $R(z, t, t')$. Specifically, from the definition of the Green functions $G^\pm(z, t, t')$, (5.2), and the reflection kernel $R(z, t, t')$, (4.1), it is straightforward to obtain for $0 \leq z \leq d$, $t > t'$

$$\begin{aligned}
G^-(z, t, t') = & R(z, \tau^+(z; 0, t), \tau^+(z; 0, t')) \frac{\partial \tau^+}{\partial t'}(z; 0, t') \\
& + \int_{t'}^t R(z, \tau^+(z; 0, t), \tau^+(z; 0, t'')) \frac{\partial \tau^+}{\partial t''}(z; 0, t'') G^+(z, t'', t') dt''
\end{aligned}$$

Notice, that

$$\left. \frac{\partial \tau^+}{\partial t}(\zeta; z, t) \right|_{\zeta=z} = 1$$

This identity is easily obtained by letting $\zeta_2 = \zeta$ and $\zeta_1 = z$ in (3.4) and differentiating with respect to t and finally letting $\zeta = z$.

For completeness, an alternative definition of the Green function equations is given.

$$\begin{cases} u^+(z, t) = u^+(0, \tau^+(0; z, t))p(z, \tau^+(0; z, t)) \\ \quad + \int_{-\infty}^{\tau^+(0; z, t)} g^+(z, t, t')p(z, t')u^+(0, t') dt' \\ u^-(z, t) = \int_{-\infty}^{\tau^+(0; z, t)} g^-(z, t, t')p(z, t')u^+(0, t') dt' \end{cases} \quad (5.7)$$

These Green functions may be more suitable for numerical computation, and the use of the transformation

$$G^\pm(z, t, t') = g^\pm(z, \tau^+(z; 0, t), t') \quad (5.8)$$

enables equations (5.3) and (5.4) to be transformed into

$$\begin{aligned} & \frac{\partial g^+}{\partial z}(z, t, t') + f(z, t) \frac{\partial g^+}{\partial t}(z, t, t') - \alpha(z, t)g^+(z, t, t') + g^+(z, t, t')\alpha(z, \tau^+(z; 0, t')) \\ & - \beta(z, t)g^-(z, t, t') - A(z, t, \tau^+(z; 0, t')) \frac{\partial \tau^+}{\partial t'}(z; 0, t') \\ & - \int_{\tau^+(z; 0, t')}^t A(z, t, t'')g^+(z, t'', t') dt'' - \int_{\tau^+(z; 0, t')}^t B(z, t, t'')g^-(z, t'', t') dt'' = 0 \end{aligned}$$

and

$$\begin{aligned} & \frac{\partial g^-}{\partial z}(z, t, t') - f(z, t) \frac{\partial g^-}{\partial t}(z, t, t') - \delta(z, t)g^-(z, t, t') + g^-(z, t, t')\alpha(z, \tau^+(z; 0, t')) \\ & - \gamma(z, t)g^+(z, t, t') - C(z, t, \tau^+(z; 0, t')) \frac{\partial \tau^+}{\partial t'}(z; 0, t') \\ & - \int_{\tau^+(z; 0, t')}^t C(z, t, t'')g^+(z, t'', t') dt'' - \int_{\tau^+(z; 0, t')}^t D(z, t, t'')g^-(z, t'', t') dt'' = 0 \end{aligned}$$

with the initial condition

$$g^-(z, t, t')|_{t'=\tau^+(0; z, t)} = -\frac{1}{2} \frac{\gamma(z, t)}{f(z, t)} \left(\frac{\partial \tau^+}{\partial t}(0; z, t) \right)^{-1}$$

The initial condition on $g^+(z, t, t')|_{t'=\tau^+(0; z, t)}$ is obtained from the transformation (5.8) and the initial condition for $G^+(z, t, t')|_{t'=t}$ in (5.6).

The relation between the reflection kernel and this alternative definition of the Green functions reads

$$g^-(z, t, t') = R(z, t, \tau^+(z; 0, t')) \frac{\partial \tau^+}{\partial t'}(z; 0, t') + \int_{\tau^+(z; 0, t')}^t R(z, t, t'')g^+(z, t'', t') dt''$$

5.1 Propagation of discontinuities

The solutions of the first order system of PDE's (5.3) and (5.4) are continuous along the characteristic curves associated with the system, but may be discontinuous across these curves.

From (5.3) it is seen that the characteristic traces are $t=\text{constant}$ for G^+ and as $G^+(0, t, t')$ is continuous for all t and t' , it follows G^+ is continuous throughout its domain of definition. However, examination of the initial condition (5.5) shows that any discontinuity in the functions γ and f will be propagated along the characteristic curves described by (5.4). The conditions imposed on these functions in Section 1 ensure $G^-(z, t, t')$ is continuous except possibly at $z = d$. The initial value for G^- has the jump discontinuity in the direction of increasing t .

$$[G^-](d, t, t) = \frac{1}{2} \frac{\gamma(d, \tau^+(d; 0, t))}{f(d, \tau^+(d; 0, t))} \frac{\partial \tau^+}{\partial t}(d; 0, t)$$

This jump in G^- will propagate along the characteristic curves of G^- .

The characteristic traces for $G^-(z, t, t')$ are independent of the third parameter t' and can be described by an equation $\eta = \eta(\zeta; z, t)$. The notation used here is similar to that used in equation (3.3). The function η satisfies the equation

$$\frac{d\eta}{d\zeta}(\zeta; z, t) = -2f(\zeta, \tau^+(\zeta; 0, \eta(\zeta; z, t))) \frac{\partial \tau^+}{\partial t}(0; \zeta, t)|_{t=\tau^+(\zeta; 0, \eta(\zeta; z, t))}$$

The discontinuity propagates along the curve Υ emanating from the line (d, t, t) and where Υ has parametric form

$$\Upsilon : \quad \mathbf{r}(z, t) = (z, \eta(z; d, t), t)$$

It follows that the equation describing the propagation of the discontinuity in G^- is

$$\left. \frac{d[G^-]}{dz} \right|_{\Upsilon} = \left(\delta(z, \tau^+(z; 0, \eta(\zeta; d, t))) - \alpha(z, \tau^+(z; 0, t)) \right) [G^-]_{\Upsilon}$$

Integrating this equation from d to z yields

$$[G^-]_{\Upsilon} = [G^-]_{\Upsilon(z=d)} \exp \left\{ \int_d^z (\delta(z', \tau^+(z'; 0, \eta(z'; d, t))) - \alpha(z', \tau^+(z'; 0, t))) dz' \right\}$$

The discontinuous behavior of g^- can be found from the relationship between g^- and G^- , see (5.8), namely

$$g^-(z, \tau^+(z; 0, t), t) = G^-(z, t, t')$$

with the substitution $t \rightarrow \eta(z; d, t)$, and use of the identity ($z = d$)

$$\tau^+(\zeta; 0, \eta(\zeta; z, t)) = \tau^-(\zeta; z, \tau^+(z; 0, t))$$

the appropriate expression for $[g^-]$ is found.

6 Explicit expressions

In this section, the theory presented in the previous sections is illustrated by the examples from Section 2.

In Section 2.1, propagation of electromagnetic waves in non-stationary, inhomogeneous, dispersive media was considered. A detailed analysis of the imbedding equation and the Green function equations for this example was presented in Ref [1], and the reader is referred to this paper for more details.

The generalized wave equation, (2.2), in Section 2.2, and the transmission line equations, (2.3), in Section 2.3 imply no significant simplifications of the results in Sections 4 and 5. However, the less complex wave equation, (2.1), offers some simplifications. Accordingly, the wave equation (2.1) has an imbedding equation

$$\begin{aligned} \frac{\partial R}{\partial z}(z, t, t') - f(z, t) \frac{\partial R}{\partial t}(z, t, t') + \frac{\partial R}{\partial t'}(z, t, t') f(z, t') = \\ + \delta(z, t) R(z, t, t') + R(z, t, t') \left[-\frac{\partial f}{\partial t'}(z, t') - \alpha(z, t') \right] \\ - \int_{t'}^t R(z, t, t'') \beta(z, t'') R(z, t'', t') dt'' \end{aligned}$$

and Green functions equations

$$\begin{aligned} \frac{\partial G^+}{\partial z}(z, t, t') - \alpha(z, \tau^+(z; 0, t)) G^+(z, t, t') \\ + G^+(z, t, t') \alpha(z, \tau^+(z; 0, t')) - \beta(z, \tau^+(z; 0, t)) G^-(z, t, t') = 0 \end{aligned}$$

and

$$\begin{aligned} \frac{\partial G^-}{\partial z}(z, t, t') - 2f(z, \tau^+(z; 0, t)) \left(\frac{\partial \tau^+}{\partial t}(z; 0, t) \right)^{-1} \frac{\partial G^-}{\partial t}(z, t, t') \\ - \delta(z, \tau^+(z; 0, t)) G^-(z, t, t') + G^-(z, t, t') \alpha(z, \tau^+(z; 0, t')) \\ - \gamma(z, \tau^+(z; 0, t)) G^+(z, t, t') = 0 \end{aligned}$$

with

$$\begin{cases} \alpha(z, t) = -\frac{1}{2} \frac{\partial}{\partial z} \ln f(z, t) - \frac{3}{2} \frac{\partial f}{\partial t}(z, t) \\ \beta(z, t) = +\frac{1}{2} \frac{\partial}{\partial z} \ln f(z, t) - \frac{1}{2} \frac{\partial f}{\partial t}(z, t) \\ \gamma(z, t) = +\frac{1}{2} \frac{\partial}{\partial z} \ln f(z, t) + \frac{1}{2} \frac{\partial f}{\partial t}(z, t) \\ \delta(z, t) = -\frac{1}{2} \frac{\partial}{\partial z} \ln f(z, t) + \frac{3}{2} \frac{\partial f}{\partial t}(z, t) \end{cases}$$

7 Conclusions

This paper contains a detailed analysis of wave propagation of transient waves in media, which properties are changing in space and time—non-stationary media. The underlying dynamics of the wave propagation problem is a general, linear,

homogeneous, non-stationary, first order 2×2 system of hyperbolic equations. A new wave splitting is introduced, which is a generalization of the well established wave splitting in media that have time translation symmetries. The scattering problem is solved by an imbedding or a Green functions technique. Specifically, the imbedding equation for the reflection kernel is derived. This equation is a non-linear, hyperbolic equation in one space and two time variables. Furthermore, the Green functions equations are derived. They constitute a system of linear, hyperbolic equations in one space and two time variables. The characteristic curves of the dynamics are discussed in some detail, and a few numerical illustrations give the typical behavior of the non-stationary properties of these characteristic curves.

Acknowledgment

The work reported in this paper is partially supported by a grant from the Swedish Research Council for Engineering Sciences and their support is gratefully acknowledged. One of the authors (DJNW) wishes to express his gratitude to the Wenner-Gren Center Foundation for a grant enabling this work to be completed.

Appendix A Straightening the characteristics

To illustrate how the characteristic of (1.1) may be straightened, consider

$$\frac{\partial u^\pm}{\partial z}(z, t) \pm f(z, t) \frac{\partial u^\pm}{\partial t}(z, t) = F^\pm(z, t, u^+, u^-) \quad (\text{A.1})$$

where $f(z, t) > 0$ in the domain of interest.

Introduce the diffeomorphic transformation of the independent variables

$$\begin{cases} z = z(x, s) \\ t = t(x, s) \end{cases}$$

with the associated inverse functions

$$\begin{cases} x = x(z, t) \\ s = s(z, t) \end{cases}$$

The PDE (A.1) can then be written in terms of the new independent variables as

$$\left(\frac{\partial x}{\partial z} \pm f \frac{\partial x}{\partial t} \right) \frac{\partial u^\pm}{\partial x} + \left(\frac{\partial s}{\partial z} \pm f \frac{\partial s}{\partial t} \right) \frac{\partial u^\pm}{\partial s} = G^\pm(x, s, u^+, u^-)$$

It is easily seen, to straighten the characteristics of the transformed equation, a necessary condition is

$$\begin{cases} \frac{\partial x}{\partial z} + f \frac{\partial x}{\partial t} = a \left(\frac{\partial s}{\partial z} + f \frac{\partial s}{\partial t} \right) \\ \frac{\partial x}{\partial z} - f \frac{\partial x}{\partial t} = b \left(\frac{\partial s}{\partial z} - f \frac{\partial s}{\partial t} \right) \end{cases} \quad (\text{A.2})$$

provided

$$f^2 \left(\frac{\partial s}{\partial t} \right)^2 - \left(\frac{\partial s}{\partial z} \right)^2 \neq 0 \quad (\text{A.3})$$

In this expression a and b are non-zero constants. The only way to violate this condition is if either: $x - as = \text{constant}$, or $x - bs = \text{constant}$.

The constants a and b cannot be equal if the transformation is to be diffeomorphic. For convenience, choose $a = 1$, $b = -1$, so converting the system (A.2) to

$$\frac{\partial}{\partial z} \begin{pmatrix} x \\ s \end{pmatrix} = \begin{pmatrix} 0 & f \\ f & 0 \end{pmatrix} \frac{\partial}{\partial t} \begin{pmatrix} x \\ s \end{pmatrix}$$

which can be converted by diagonalization to the uncoupled system

$$\frac{\partial}{\partial z} \begin{pmatrix} v_1 \\ v_2 \end{pmatrix} = \begin{pmatrix} -f & 0 \\ 0 & f \end{pmatrix} \frac{\partial}{\partial t} \begin{pmatrix} v_1 \\ v_2 \end{pmatrix}$$

where

$$\begin{pmatrix} v_1 \\ v_2 \end{pmatrix} = \frac{1}{2} \begin{pmatrix} -1 & 1 \\ 1 & 1 \end{pmatrix} \begin{pmatrix} x \\ s \end{pmatrix}, \quad \begin{pmatrix} x \\ s \end{pmatrix} = \begin{pmatrix} -1 & 1 \\ 1 & 1 \end{pmatrix} \begin{pmatrix} v_1 \\ v_2 \end{pmatrix}$$

A convenient set of initial conditions for x and s is

$$\begin{cases} x(z, 0) = \int_0^z f(z', 0) dz' \\ s(z, 0) = 0 \end{cases}$$

This initial value problem for the hyperbolic system has a unique solution, which means that the characteristics can always be straightened. In fact, these initial conditions imply that (A.3) is always satisfied, since $f(z, t) > 0$.

In the special case that $f = f(z)$ then the solution of these systems yields

$$\begin{cases} x(z, t) = \int_0^z f(z') dz' \\ s(z, t) = t \end{cases}$$

This is the well known travel time transformation.

Appendix B Duhamel's integral

The derivation of the imbedding equation in Section 4 and the Green functions equations in Section 5 relies on a result that is obtained from Duhamel's integral [8]. Since the basic first order 2×2 system of equations, (1.1), has coefficients varying both in space and time, a slight modification of the standard result is needed. Therefore, it is of interest here to give a few of the intermediate steps leading to the relation (4.1), which defines the reflection kernel $R(z, t, t')$, and to equation (5.2) defining the Green functions $G^\pm(z, t, t')$.

In order to cover both the definition of the reflection kernel and the definition of the Green functions, a sub-section (z_0, d) of the physical slab $(0, d)$ is considered.

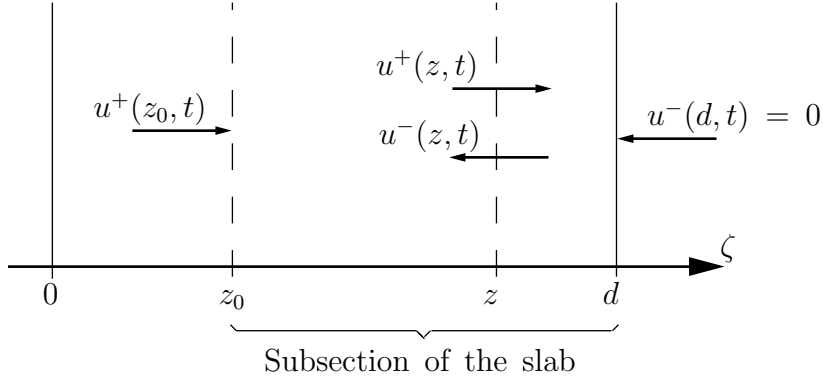

Figure 4: The geometry used in Appendix B.

The full slab $(0, d)$ is therefore imbedded in a one-parameter family of sub-slabs (z_0, d) , where the left end of the slab z_0 varies between 0 and d , see Figure 4.

The basic dynamics of the problem is given by (1.1).

$$\begin{aligned} \frac{\partial}{\partial z} \begin{pmatrix} u^+(z, t) \\ u^-(z, t) \end{pmatrix} = f(z, t) \begin{pmatrix} -1 & 0 \\ 0 & 1 \end{pmatrix} \frac{\partial}{\partial t} \begin{pmatrix} u^+(z, t) \\ u^-(z, t) \end{pmatrix} + \begin{pmatrix} \alpha(z, t) & \beta(z, t) \\ \gamma(z, t) & \delta(z, t) \end{pmatrix} \begin{pmatrix} u^+(z, t) \\ u^-(z, t) \end{pmatrix} \\ + \int_{-\infty}^t \begin{pmatrix} A(z, t, t') & B(z, t, t') \\ C(z, t, t') & D(z, t, t') \end{pmatrix} \begin{pmatrix} u^+(z, t') \\ u^-(z, t') \end{pmatrix} dt' \end{aligned} \quad (\text{B.1})$$

The domain of interest in this appendix is $z_0 < z < d$, $t > 0$.

Problem 1.

A specific solution to equation (B.1) is now considered. This solution satisfies the following mixed initial-boundary value ($t' > 0$):

$$\begin{cases} u^\pm(z, 0) = 0 & , z_0 < z < d \\ u^+(z_0, t) = H(t - t') & , t > 0 \\ u^-(d, t) = 0 & , t > 0 \end{cases}$$

The boundary condition at $z = d$ shows that there are no sources in the region to the right of the slab, $z > d$.

The solution to this problem, which is assumed to be unique, depends on the parameters $z_0 \in (0, d)$ and $t' > 0$, and the solution is denoted $U^\pm(z, t; z_0, t')$, i.e.

$$u^\pm(z, t) = U^\pm(z, t; z_0, t')$$

Causality implies that $U^\pm(z, t; z_0, t') = 0$ for $t' > \tau^+(z_0; z, t)$, or stated equivalently, $t < \tau^+(z; z_0, t')$. The variable t' denotes the starting time of the excitation at the left boundary z_0 of the sub-slab (z_0, d) . If the medium is invariant under time translations, the solution is only a function of z and z_0 , and the difference $t - t'$.

The solutions $U^\pm(z, t; z_0, t')$ are continuously differentiable everywhere, except along the characteristics of the u^+ -equation, see Section 3. With the method of

characteristics, it is straightforward to show that U^- is continuous at the leading edge, while U^+ has a finite jump discontinuity there. The leading edge is defined as the characteristic curve in the (z, t) -plane passing through the point (z_0, t') , i.e. $t = \tau^+(z; z_0, t')$, $z_0 < z < d$. The explicit values at the leading edge are:

$$\begin{cases} U^+(z, t; z_0, \tau^+(z_0; z, t)) = \exp \left\{ \int_{z_0}^z \alpha(\zeta, \tau^+(\zeta; z, t)) d\zeta \right\} \\ U^-(z, t; z_0, \tau^+(z_0; z, t)) = 0 \end{cases}$$

Problem 2.

Consider now the solution of equation (B.1) subject to the mixed initial-boundary value ($t' > 0$)

$$\begin{cases} u^\pm(z, 0) = 0 & , z_0 < z < d \\ u^+(z_0, t) = g(t) & , t > 0 \\ u^-(d, t) = 0 & , t > 0 \end{cases} \quad (\text{B.2})$$

Again, the boundary condition at $z = d$ shows that there are no sources in the region to the right of the slab, $z > d$. Here, $g(t)$ is an arbitrary continuously differentiable function, which for $t > 0$ can be approximated from below by the piecewise constant function

$$g_1(t) = g(0)H(t) + \sum_{k=1}^{\infty} [g(k\Delta t') - g((k-1)\Delta t')] H(t - k\Delta t')$$

Due to the linearity of the equations (B.1), superposition is used to find the solution of the approximate boundary value $g_1(t)$. In the limit, $\Delta t' \rightarrow 0$, the result is

$$u^\pm(z, t) = u^\pm(z_0, 0)U^\pm(z, t; z_0, 0) + \int_0^{\tau^+(z_0; z, t)} \frac{\partial u^\pm}{\partial t'}(z_0, t')U^\pm(z, t; z_0, t') dt'$$

where the causality of the solutions $U^\pm(z, t; z_0, t')$ has been used to truncate the infinite integration range, and furthermore, the substitution $g(t) = u^+(z_0, t)$ for $t > 0$ has been made. It is easy to verify that the expressions $u^\pm(z, t)$ satisfy the given mixed initial-boundary value problem, with the use of (3.5) and the fact that $U^-(z, t; z_0, \tau^+(z_0; z, t)) = 0$. Integration by parts now shows that the unique solution of the mixed boundary value problem (B.1) and (B.2) is

$$\begin{cases} u^+(z, t) = u^+(z_0, \tau^+(z_0; z, t))U^+(z, t; z_0, \tau^+(z_0; z, t)) \\ \quad - \int_0^{\tau^+(z_0; z, t)} u^+(z_0, t') \frac{\partial U^+}{\partial t'}(z, t; z_0, t') dt' \\ u^-(z, t) = - \int_0^{\tau^+(z_0; z, t)} u^+(z_0, t') \frac{\partial U^-}{\partial t'}(z, t; z_0, t') dt' \end{cases} \quad (\text{B.3})$$

These equations now offer two possibilities, namely to define the reflection kernel $R(z_0, t, t')$ of the sub-slab (z_0, d) , and the Green functions $G^\pm(z, t, t')$ of the full slab $(0, d)$.

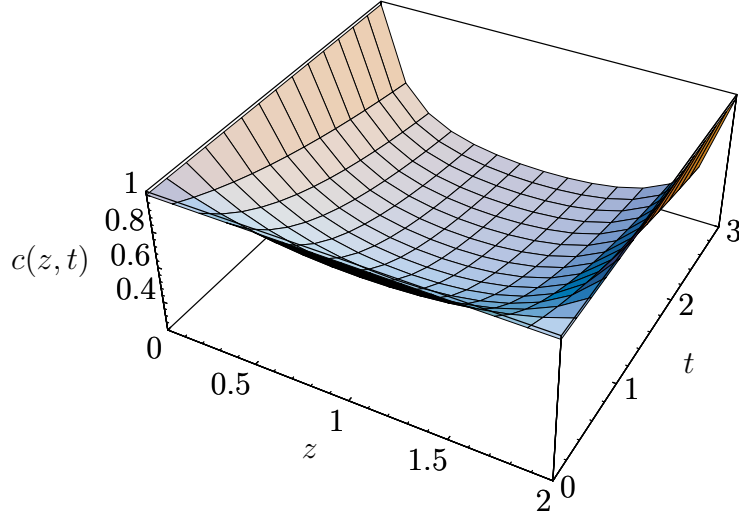

Figure 5: The velocity profile $c(z, t) = 1/(1 + z(d - z)t)$, where $d = 2$.

For the definition of the reflection kernel use the second equation in (B.3) and let $z = z_0$. Define the reflection kernel

$$R(z_0, t, t') = -\frac{\partial U^-}{\partial t'}(z_0, t; z_0, t')$$

The relation between the u^\pm -waves at the left end point of the sub-slab is (the subscript on z_0 is dropped):

$$u^-(z, t) = \int_{-\infty}^t R(z, t, t') u^+(z, t') dt'$$

which is identical to (4.1).

In the definition of the Green functions $G^\pm(z, t, t')$, let $z_0 = 0$ in (B.3). The result is

$$\begin{cases} u^+(z, t) = u^+(0, \tau^+(0; z, t)) p(z, \tau^+(0; z, t)) - \int_0^{\tau^+(0; z, t)} u^+(0, t') \frac{\partial U^+}{\partial t'}(z, t; 0, t') dt' \\ u^-(z, t) = - \int_0^{\tau^+(0; z, t)} u^+(0, t') \frac{\partial U^-}{\partial t'}(z, t; 0, t') dt' \end{cases}$$

where

$$p(z, t) = \exp \left\{ \int_0^z \alpha(\zeta, \tau^+(\zeta; 0, t)) d\zeta \right\}$$

It is convenient to introduce an extra factor $p(z, t')$ in the definition of the Green functions. Therefore, the definition of $G^\pm(z, t, t')$ is

$$\begin{cases} -\frac{\partial}{\partial t'} U^+(z, t; 0, t') = p(z, t') G^+(z, \tau^+(0; z, t), t') \\ -\frac{\partial}{\partial t'} U^-(z, t; 0, t') = p(z, t') G^-(z, \tau^+(0; z, t), t') \end{cases}$$

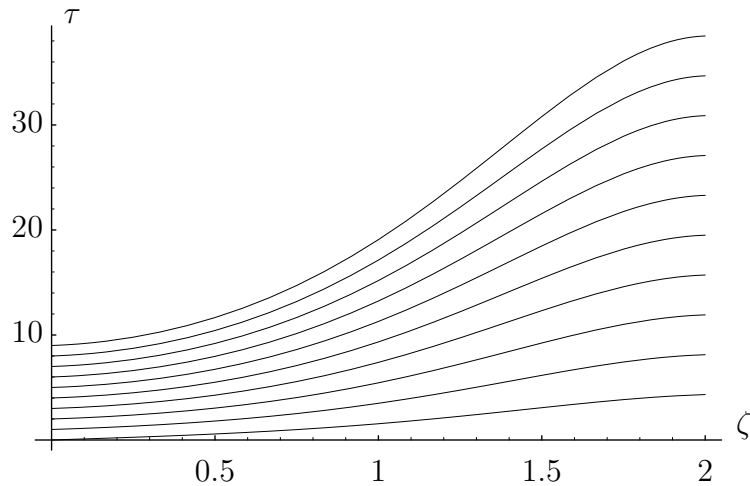

Figure 6: A set of characteristics for the case, $f(z, t) = 1 + z(d - z)t$, where $d = 2$.

Appendix C Examples on characteristics of the u^+ -equation

The explicit form of the function f determines whether a closed form expression can be found for the characteristics in (3.1) or not. In most cases this is not possible. In this section, the theory of the characteristics is illustrated with an analytic and a numerical example.

Analytic example: The function $f(z, t)$ has to be consistent with the boundary conditions, (1.2), given in Section 1, and simple enough to permit closed form solutions of (3.1). Thus, for $\tau^+ \geq 0$ and $0 \leq \zeta \leq d$ let

$$f(\zeta, \tau^+) = \frac{1}{v_0} [1 + a\zeta(d - \zeta)\tau^+]$$

Here d is the thickness of the slab, v_0 is a constant and a a parameter. Outside the slab, i.e. for $\zeta < 0$ or $\zeta > d$, and everywhere for $\tau^+ < 0$, let

$$f(\zeta, \tau^+) = \frac{1}{v_0}$$

Figure 5 shows the velocity profile $c(z, t)$ inside the slab ($d = 2$), surrounded by a medium with the constant wave velocity $v_0 = 1$, and $a = 1$. A set of characteristics for this case is illustrated in Figure 6.

If f is inserted into equation (3.1), a linear first order ordinary differential equation in $\tau^+(\zeta)$ is obtained. This equation is easily solvable after multiplication with the integrating factor $e^{g(\zeta)}$ where

$$g(\zeta) = \frac{1}{v_0} a \left(-\frac{1}{2} d\zeta^2 + \frac{1}{3} \zeta^3 \right)$$

The explicit form of the characteristic curve passing through the point (z, t) is

$$\tau^+(\zeta; z, t) = t e^{g(z)} e^{-g(\zeta)} + \frac{1}{v_0} e^{-g(\zeta)} \int_z^\zeta e^{g(\zeta')} d\zeta'$$

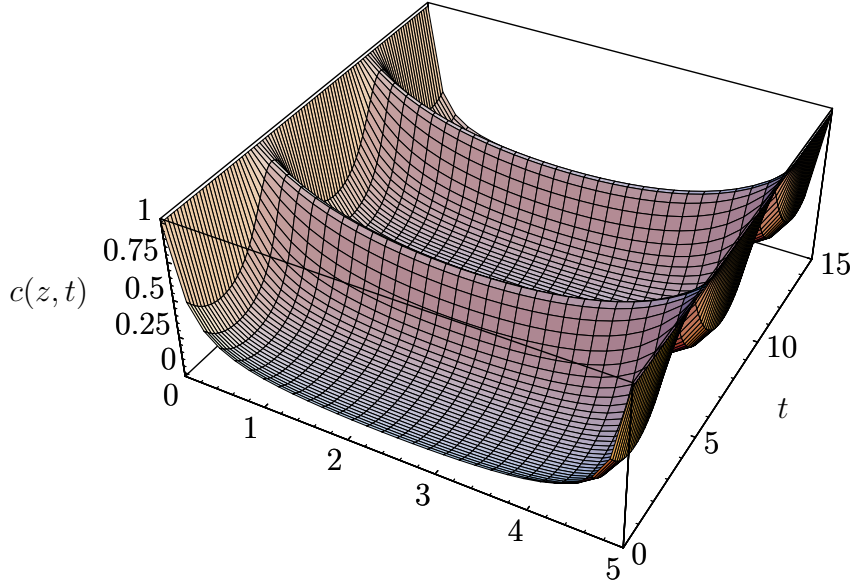

Figure 7: The velocity profile $c(z, t)$ for the example in (C.1) for $d = 5$.

Specifically, the solution at $\zeta = 0$ is

$$\tau^+(0; z, t) = te^{g(z)} - \frac{1}{v_0} \int_0^z e^{g(\zeta')} d\zeta'$$

and the solution at z starting at $(0, t)$ is

$$\tau^+(z; 0, t) = te^{-g(z)} + \frac{1}{v_0} e^{-g(z)} \int_0^z e^{g(\zeta')} d\zeta'$$

Differentiation with respect to t and z gives

$$\frac{\partial \tau^+(\zeta; z, t)}{\partial t} = e^{g(z)} e^{-g(\zeta)}$$

and

$$\frac{\partial \tau^+(\zeta; z, t)}{\partial z} = tg'(z)e^{g(z)}e^{-g(\zeta)} - \frac{1}{v_0}e^{g(z)}e^{-g(\zeta)} = -f(z, t)e^{g(z)}e^{-g(\zeta)}$$

and (3.5) is satisfied.

Numerical example: In Figures 7 and 8, the phase velocity and a set of characteristics, respectively, for a non-linear case are depicted. The phase velocity of the non-stationary medium in this example is

$$f(z, t) = \begin{cases} 1 & , z < 0 \\ 1 + z(d - z)(1.1 + \sin t) & , 0 < z < d \\ 1 & , z > d \end{cases} \quad (\text{C.1})$$

These curves have been obtained by numerical integration.

Note that the flow depicted by Figures 6 and 8 illustrates a flow field that is non-area preserving, i.e. the flow field has non-zero divergence (compressible). Compare this with Figure 9 for which $f(z, t) = f(z)$ and so the flow field is area preserving.

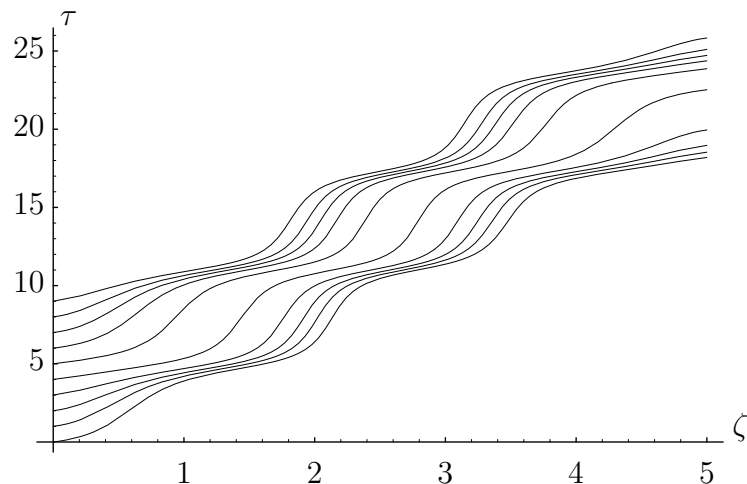

Figure 8: A set of characteristics for the example in (C.1) for $d = 5$.

References

- [1] I. Åberg, G. Kristensson, and D.J.N. Wall. Propagation of transient electromagnetic waves in time-varying media—direct and inverse scattering problems. *Inverse Problems*, **11**(1), 29–49, 1995.
- [2] D.K. Arrowsmith and C.M. Place. *An Introduction to Dynamical Systems*. Cambridge University Press, Cambridge, 1990.
- [3] R.S. Beezley and R.J. Krueger. An electromagnetic inverse problem for dispersive media. *J. Math. Phys.*, **26**(2), 317–325, 1985.
- [4] E.A. Coddington and N. Levinson. *Theory of Ordinary Differential Equations*. McGraw-Hill Book Company, New York, 1955.
- [5] J.P. Coronas, M.E. Davison, and R.J. Krueger. Direct and inverse scattering in the time domain via invariant imbedding equations. *J. Acoust. Soc. Am.*, **74**(5), 1535–1541, 1983.
- [6] J.P. Coronas, M.E. Davison, and R.J. Krueger. Wave splittings, invariant imbedding and inverse scattering. In A.J. Devaney, editor, *Inverse Optics*, pages 102–106, SPIE Bellingham, WA, 1983. Proc. SPIE 413.
- [7] J.P. Coronas, G. Kristensson, P. Nelson, and D.L. Seth, editors. *Invariant Imbedding and Inverse Problems*. SIAM, 1992.
- [8] R. Courant and D. Hilbert. *Methods of Mathematical Physics*, volume 2. Interscience, New York, 1962.
- [9] E. Hille. *Lectures on Ordinary Differential Equations*. Addison-Wesley, Reading, 1969.

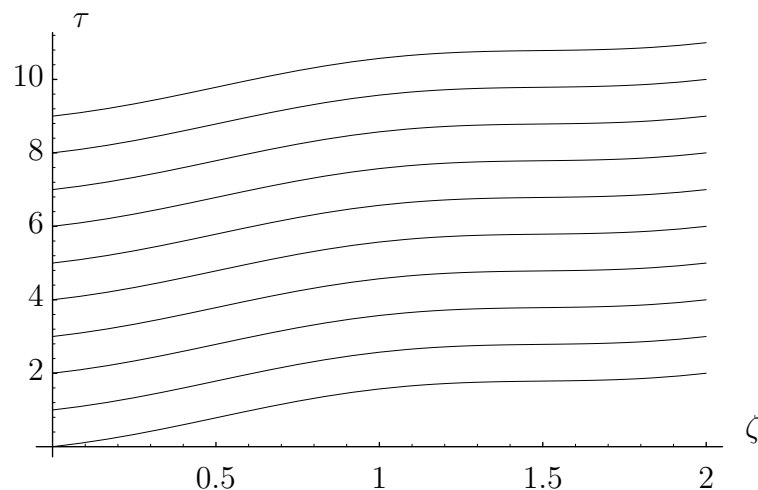

Figure 9: A set of characteristics for the stationary case, $f(z) = 1 + 0.9 \sin 2\pi z/d$, where $d = 2$.

- [10] F. John. *Partial differential equations*. Springer Verlag, New York Heidelberg Berlin, third edition, 1978.
- [11] G. Kristensson. Direct and inverse scattering problems in dispersive media—Green’s functions and invariant imbedding techniques. In Kleinman R., Kress R., and Martensen E., editors, *Direct and Inverse Boundary Value Problems, Methoden und Verfahren der Mathematischen Physik, Band 37*, pages 105–119, Mathematisches Forschungsinstitut Oberwolfach, FRG, 1991.
- [12] R.J. Krueger and R.L. Ochs, Jr. A Green’s function approach to the determination of internal fields. *Wave Motion*, **11**, 525–543, 1989.
- [13] L.P. Nizhnik. Inverse problem of nonstationary scattering. *Soviet Math. Dokl.*, **12**(1), 306–310, 1971.
- [14] L.P. Nizhnik. The inverse scattering problems for the hyperbolic equations and their application to non-linear integrable systems. *Reports on Mathematical Physics*, **26**(2), 261–283, 1988.
- [15] L.P. Nizhnik and V.G. Tarasov. The inverse scattering problems for an integrodifferential equation. *Selecta Mathematica Sovietica*, **10**(3), 219–236, 1991.
- [16] V.H. Weston. Invariant imbedding for the wave equation in three dimensions and the applications to the direct and inverse problems. *Inverse Problems*, **6**, 1075–1105, 1990.
- [17] V.H. Weston. Invariant imbedding and wave splitting in \mathbf{R}^3 : II. The Green function approach to inverse scattering. *Inverse Problems*, **8**, 919–947, 1992.